

# 3GPP TS 48.103 V11.0.0 (2012-09)

---

*Technical Specification*

**3rd Generation Partnership Project;  
Technical Specification Group GSM/EDGE Radio Access Network;  
Base Station System – Media GateWay (BSS-MGW) interface;  
User plane transport mechanism  
(Release 11)**



The present document has been developed within the 3<sup>rd</sup> Generation Partnership Project (3GPP™) and may be further elaborated for the purposes of 3GPP.

The present document has not been subject to any approval process by the 3GPP Organizational Partners and shall not be implemented. This Specification is provided for future development work within 3GPP only. The Organizational Partners accept no liability for any use of this Specification. Specifications and reports for implementation of the 3GPP™ system should be obtained via the 3GPP Organizational Partners' Publications Offices.

---

Keywords

---

GSM, network

**3GPP**

Postal address

---

3GPP support office address

---

650 Route des Lucioles - Sophia Antipolis  
Valbonne - FRANCE  
Tel.: +33 4 92 94 42 00 Fax: +33 4 93 65 47 16

Internet

---

<http://www.3gpp.org>

---

**Copyright Notification**

---

No part may be reproduced except as authorized by written permission.  
The copyright and the foregoing restriction extend to reproduction in all media.

© 2012, 3GPP Organizational Partners (ARIB, ATIS, CCSA, ETSI, TTA, TTC).  
All rights reserved.

UMTS™ is a Trade Mark of ETSI registered for the benefit of its members  
3GPP™ is a Trade Mark of ETSI registered for the benefit of its Members and of the 3GPP Organizational Partners  
LTE™ is a Trade Mark of ETSI currently being registered for the benefit of its Members and of the 3GPP Organizational Partners  
GSM® and the GSM logo are registered and owned by the GSM Association

# Contents

|  |           |
|--|-----------|
| Foreword .....   | 4         |
| 1 Scope .....  | 5         |
| 2 References.....  | 5         |
| 3 Definitions, symbols and abbreviations .....                                 | 6         |
| 3.1 Definitions .....  | 6         |
| 3.2 Abbreviations.....   | 6         |
| 4 Transport over TDM .....   | 7         |
| 4.1 General .....  | 7         |
| 4.2 Transport during local switching .....                                     | 7         |
| 5 Transport over IP .....  | 7         |
| 5.1 General .....  | 7         |
| 5.2 IP .....   | 8         |
| 5.3 UDP .....  | 8         |
| 5.4 Transport without RTP multiplexing .....                                   | 8         |
| 5.4.1 Introduction.....  | 8         |
| 5.4.2 RTP .....  | 8         |
| 5.4.2.1 RTP Header.....  | 8         |
| 5.4.2.1.1 Version.....   | 8         |
| 5.4.2.1.2 Padding.....   | 8         |
| 5.4.2.1.3 Extension.....   | 8         |
| 5.4.2.1.4 Contributing Source (CSRC) count .....                               | 8         |
| 5.4.2.1.5 Marker Bit .....   | 9         |
| 5.4.2.1.6 Payload Type .....   | 9         |
| 5.4.2.1.7 Sequence Number .....  | 9         |
| 5.4.2.1.8 Timestamp .....  | 9         |
| 5.4.2.1.9 Synchronisation Source (SSRC) .....                                  | 9         |
| 5.4.2.1.10 CSRC list.....  | 9         |
| 5.4.2.2 RTP Payload .....  | 9         |
| 5.4.2.3 RTP Packetization Time .....   | 10        |
| 5.4.3 RTCP .....   | 10        |
| 5.5 Transport with RTP multiplexing .....                                      | 10        |
| 5.5.1 Introduction.....  | 10        |
| 5.5.2 RTP .....  | 11        |
| 5.5.2.1 Transport format for multiplexing without RTP header compression ..... | 11        |
| 5.5.2.2 Transport format for multiplexing with RTP header compression .....    | 12        |
| 5.5.3 RTCP .....   | 13        |
| 5.5.3.1 General.....   | 13        |
| 5.5.3.2 Multiplexing negotiation via RTCP.....                                 | 13        |
| 5.5.3.3 RTCP Multiplexing packet .....   | 14        |
| 5.6 Transport of CSData .....  | 15        |
| 5.6.1 Introduction.....  | 15        |
| 5.6.2 Transport formats for CSData .....                                       | 16        |
| 5.6.2.1 Transport format for CSData without redundancy.....                    | 16        |
| 5.6.2.2 Transport format for CSData with redundancy .....                      | 17        |
| 5.6.2.3 Start and Stop of RTP streams with redundancy.....                     | 18        |
| 5.7 Transport during local switching .....                                     | 19        |
| <b>Annex A (informative): Change history.....</b>                              | <b>19</b> |

---

# Foreword

This Technical Specification has been produced by the 3<sup>rd</sup> Generation Partnership Project (3GPP).

The contents of the present document are subject to continuing work within the TSG and may change following formal TSG approval. Should the TSG modify the contents of the present document, it will be re-released by the TSG with an identifying change of release date and an increase in version number as follows:

Version x.y.z

where:

- x the first digit:
  - 1 presented to TSG for information;
  - 2 presented to TSG for approval;
  - 3 or greater indicates TSG approved document under change control.
- y the second digit is incremented for all changes of substance, i.e. technical enhancements, corrections, updates, etc.
- z the third digit is incremented when editorial only changes have been incorporated in the document.

# 1 Scope

The present document specifies the User Plane data transport protocols used between BSSs and the Core Network (MGWs) across the A interface. The main purpose of the present document is the AoIP description, however for the sake of completeness the AoTDM case is described as well.

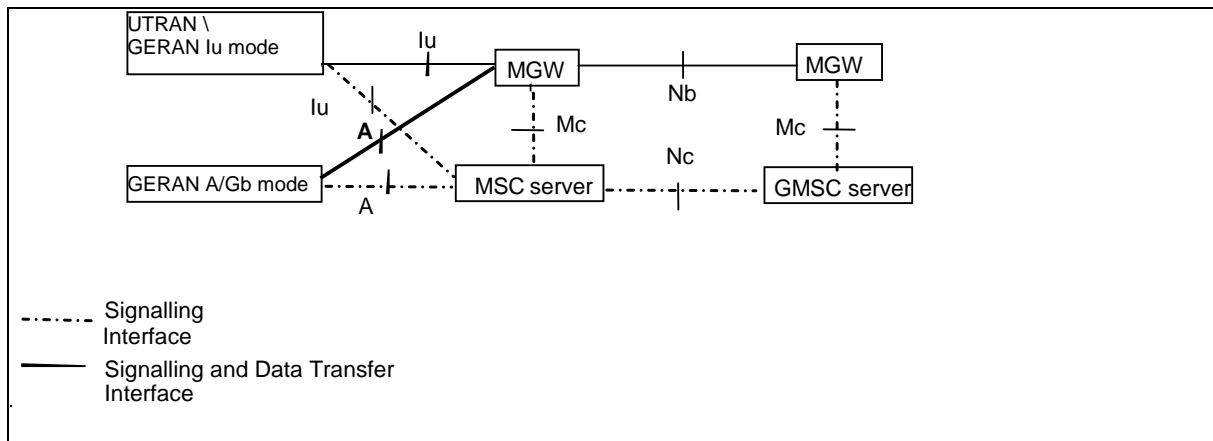

**Figure 1.1: CS core network logical architecture**

Note that the present document does not preclude any Core Network Session Control Protocol implementation (BICC or SIP-I).

# 2 References

The following documents contain provisions which, through reference in this text, constitute provisions of the present document.

- References are either specific (identified by date of publication, edition number, version number, etc.) or non-specific.
- For a specific reference, subsequent revisions do not apply.
- For a non-specific reference, the latest version applies. In the case of a reference to a 3GPP document (including a GSM document), a non-specific reference implicitly refers to the latest version of that document *in the same Release as the present document*.

- [1] 3GPP TR 21.905: "Vocabulary for 3GPP Specifications".
- [2] IETF RFC 791: "Internet Protocol (IP)".
- [3] IETF RFC 2460: "Internet Protocol, Version 6 (IPv6)".
- [4] IETF RFC 768: "User Datagram Protocol. (UDP)".
- [5] IETF RFC 3550: "RTP: A Transport Protocol for Real Time Applications".
- [6] 3GPP TS 29.414: "Core network Nb Interface data transport and transport signalling".
- [7] IETF RFC 3551: "RTP Profile for Audio and Video Conference with Minimal Control".
- [8] 3GPP TR 29.814: "Feasibility Study on Bandwidth Savings at Nb Interface with IP transport".
- [9] IETF RFC 4040: "RTP Payload Format for a 64 kbits/s Transparent Call"
- [10] IETF RFC 4867: "RTP Payload Format and File Storage Format for the Adaptive Multi-Rate (AMR) and Adaptive Multi-Rate Wideband (AMR-WB) Audio Codecs"

- [11] IETF RFC 2198: "RTP Payload for redundant Audio Data"
- [12] 3GPP TR 43.903 A-Interface over IP Study (AINTIP)
- [13] 3GPP TS 48.001 "Base Station System – Mobile-services Switching Centre (BSS - MSC) interface; General aspects"
- [14] ITU-T Recommendation G.705: "Characteristics of plesiochronous digital hierarchy (PDH) equipment functional blocks".
- [15] ANSI T1.102-1993: "Digital Hierarchy - Electrical Interface".
- [16] ITU-T Recommendation G.711: "Pulse Code Modulation (PCM) of voice frequencies".
- [17] 3GPP TS 48.020: "Rate adaption on the Base Station System - Mobile-services Switching Centre (BSS - MSC) interface".
- [18] IETF RFC 5993 (2010) "RTP Payload Format for Global System for Mobile Communications Half Rate (GSM-HR)".
- [19] 3GPP TS 48.008: "Mobile Switching Centre - Base Station System (MSC-BSS) interface; Layer 3 specification".
- [20] 3GPP TS 26.102: "Adaptive Multi-Rate (AMR) speech codec; Interface to Iu, Uu and Nb".
- [21] 3GPP TS 23.284: "Local Call Local Switch; Stage 2".

---

## 3 Definitions, symbols and abbreviations

### 3.1 Definitions

For the purposes of the present document, the terms and definitions given in TR 21.905 [1] and the following apply.

- Intra-BSS call: A mobile to mobile voice call involving two mobile stations connected to the same BSS.
- Local call: An Intra-BSS call that can be locally switched by the BSS. For details on the Local Switch Service see 3GPP TS 23.284 [21].
- Access MGW: The MGW interfacing to the Radio Access Network

### 3.2 Abbreviations

For the purposes of the present document, the abbreviations given in TR 21.905 [1] and the following apply. An abbreviation defined in the present document takes precedence over the definition of the same abbreviation, if any, in TR 21.905 [1].

|        |   |
|--------|---|
| AoIP   | A (interface) over IP   |
| AoTDM  | A (interface) over TDM  |
| APP    | APPLication   |
| BICC   | Bearer Independent Call Control                                 |
| BSS    | Base Station Subsystem  |
| CS     | Circuit-Switched  |
| CSData | CS Data and fax   |
| IETF   | Internet Engineering Task Force                                 |
| IP     | Internet Protocol   |
| IPv4   | Internet Protocol version 4                                     |
| IPv6   | Internet Protocol version 6                                     |
| ITU-T  | International Telecommunications Union-Telecommunication sector |
| MGW    | Media GateWay   |
| PCM    | Pulse-Coded Modulation  |
| RFC    | Request For Comment   |

|       |  |
|-------|--|
| RTP   | Real-Time Transport Protocol                       |
| RTCP  | Real-Time Transport Control Protocol               |
| SIP-I | Session Initiation Protocol with encapsulated ISUP |
| SSRC  | Synchronisation Source                             |
| SVC   | Switched Virtual Circuit                           |
| TDM   | Time-Division Multiplexing                         |
| UDP   | User Datagram Protocol                             |
| UP    | User Plane   |

---

## 4 Transport over TDM

### 4.1 General

The present chapter describes the transport on the A Interface UP over E1/T1 interface; for more information see 3GPP TS 48.001 [13]. Figure 4.1 shows the protocol stack for the transport network user plane on the A interface.

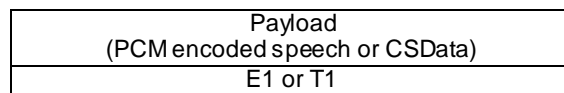

**Figure 4.1: TDM Protocol stack for the A interface user plane**

Layer 1 shall utilise digital transmission:

- at a rate of 2 048 kbit/s with a frame structure of 32 x 64kbit/s time slots, as specified in ITU-T Recommendation G.705 [14] clause 3 for E1 interface; or
- at a rate of 1 544 kbit/s with a frame structure of 24 x 64 kbit/s time slots, as specified in T1.102 specification for T1 interface [15].

The payload is either PCM encoded speech (see ITU-T Recommendation G.711 [16]) or CSData (see 3GPP TS 48.020 [17]).

### 4.2 Transport during local switching

When a local switch path is established in the BSS for a local call, the user plane between the BSS and the Access MGWs for both the call legs in uplink and downlink shall not be released.

---

## 5 Transport over IP

### 5.1 General

The present chapter describes the transport of the A-Interface User Plane Payload by RTP/UDP/IP. Figure 5.1 shows the protocol stack.

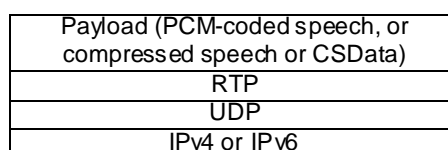

**Figure 5.1: IP Protocol stack for the A-Interface user plane**

The specific carrying way at physical/link layer of the IP protocol is not limited by the present document; if Ethernet is adopted, link layer will be MAC protocol while if IPoE1 or POS is adopted, link layer will be PPP protocol. Nevertheless at least Ethernet should be supported.

## 5.2 IP

IPv4 (RFC 791 [2]) shall be supported

IPv6 (RFC 2460 [3]) may be supported as an option.

One BSS/MGW pair may be connected via several IP interfaces.

## 5.3 UDP

The UDP Protocol (see RFC 768 [4]) shall be applied.

Two consecutive port numbers shall be used at each BSS/MGW for the RTP connection and for the optional RTCP connection that corresponds to a single A interface UP connection. Two such consecutive port numbers are termed "port number block" in what follows. The first port number shall be even and shall be assigned to the RTP protocol. For a given BSS/MGW, the same port shall be used to send and to receive RTP PDUs. The next port number shall be assigned to the RTCP protocol. This port shall be reserved even if the optional RTCP protocol is not used.

If multiplexing is applied with or without header compression, the source UDP port number shall indicate the local termination used to combine the multiplexed packet and the destination UDP port number shall indicate the remote port number where PDUs are demultiplexed. The negotiation of whether multiplexing is applied and of the destination UDP port is described in sub-clause 5.5.3.2. If multiplexing was negotiated for an A interface UP user plane connection, the BSS/MGW may apply multiplexing by sending all packets of the user plane connection (multiplexed with other user plane connections packets) towards the negotiated destination UDP port.

## 5.4 Transport without RTP multiplexing

### 5.4.1 Introduction

User Plane transport without RTP multiplexing is default and shall be supported. It shall be applied after call setup, until a User Plane transport with RTP-multiplexing is negotiated via RTCP, see clause 5.5. RTCP, see RFC 3550 [5] may be applied in AoIP, it is optional. A BSS or MSC may ignore incoming RTCP packets on AoIP.

### 5.4.2 RTP

The RTP protocol (see RFC 3550 [5]) shall be applied.

#### 5.4.2.1 RTP Header

The RTP Header Fields shall be used as described in the following sub-clauses:

##### 5.4.2.1.1 Version

RTP Version 2 shall be used.

##### 5.4.2.1.2 Padding

Padding shall not be used.

##### 5.4.2.1.3 Extension

The RTP Header extension shall not be used.

##### 5.4.2.1.4 Contributing Source (CSRC) count

There is zero CSRC.



#### 5.4.2.1.5 Marker Bit

The marker bit shall be used as specified for the RTP profile applicable for the used payload. If AMR or AMR-WB speech is received via the GSM radio interface, then an ONSET frame precedes the first speech frame. This ONSET Frame is transported in a separate RTP packet and shall also have the Marker Bit set to "1". Also the next RTP packet, which contains the first speech frame of the talkspurt, shall have the Marker Bit set to "1". In case of lost speech frames due to radio errors or due to FACCH frame stealing the Marker bit shall not be set in the first speech frame after that interruption.

#### 5.4.2.1.6 Payload Type

See sub-clause 5.4.2.2.

#### 5.4.2.1.7 Sequence Number

The sequence number shall be supplied by the source (BSS or MGW) of an RTP packet. RTP sequence numbering is based on sent RTP packets, not on expected speech frames. If frames are lost or stolen on the radio interface and the codec does not support Bad or No\_Data frame types, no RTP packet is sent in uplink direction and the RTP Sequence Number is not incremented, until a next frame is sent in RTP. This ensures that the receiver of the RTP stream can detect lost RTP packets by inspecting the RTP Sequence Number.

#### 5.4.2.1.8 Timestamp

The timestamp shall be supplied by the source (BSS or MGW) of a RTP PDU. Depending of the (pseudo) codec used a clock frequency of either 8 or 16 kHz shall be used, as described in sub-clause 5.4.2.2. In case of lost or stolen frames on the radio interface or in case of an interruption of the RTP stream due to handover, the RTP Timestamp shall be incremented as if no frame would have been lost. This ensures that the receiver of the RTP stream can regenerate the time signal correctly.

NOTE: IETF RFC 3550 [5] specifies that the RTP timestamp is based on the sampling instant of the source Encoder. In case of a circuit switched radio interface the source Encoder for the uplink is within the mobile station. But the radio interface does not support the transfer of a RTP Timestamp. The clock synchronisation between mobile station and BSS is, however, very precise and so the BSS can take the role of the source Encoder and provide the RTP time stamp.

#### 5.4.2.1.9 Synchronisation Source (SSRC)

The source (BSS or MGW) of a RTP PDU shall supply a SSRC. The receiver of a RTP PDU may ignore the SSRC if it does not use RTCP.

#### 5.4.2.1.10 CSRC list

This list is empty, i.e. not present.

### 5.4.2.2 RTP Payload

The packing of the RTP Payload for each Speech Codec Type is specified in TS 26.102 [20].

When defined as such by IETF for a given Speech Codec (see RFC 3550 [5] and RFC 3551 [7]) the "Static" Payload Type is used; otherwise for RTP profiles for which IETF defines the Payload Type as "Dynamic" (e.g. for AMR codecs, see RFC4867 [10]) a fixed Payload Type is defined for AoIP in the range of the dynamic Payload Types, see below.

The mapping between transported RTP payloads and their associated Payload Type is as follows:

**Table 5.4.2.2.1: Type of data transported versus RTP Payload Type**

| Type of data transported                            |  | RTP Payload Type     | Clock frequency                            |
|---|--|----------------------|--|
| PCM $\mu$ -law encoded speech (G.711)               |  | 0 (see RFC 3551 [7]) | 8 kHz (see RFC 3551 [7])                   |
| PCM A-law encoded speech (G.711)                    |  | 8 (see RFC 3551 [7]) | 8 kHz (see RFC 3551 [7])                   |
| Compressed Speech                                   | GSM FR codec (3GPP TS 46.010)  | 3 (see RFC 3551 [7]) | 8 kHz (see RFC 3551 [7])                   |
|   | GSM EFR codec (3GPP TS 46.060)   | 110                  | 8 kHz (see RFC 3551 [7])                   |
|   | GSM HR codec (3GPP TS 46.020)  | 111                  | 8 kHz (see [18])                           |
|   | Narrow Band AMR codecs (i.e. FR AMR, HR AMR and OHR AMR codecs) (3GPP TS 29.190)   | 112                  | 8 kHz (see RFC4867 [10])                   |
|   | Wide Band AMR codecs (i.e. AMR-WB, OFR AMR-WB and OHR AMR-WB codecs) (3GPP TS 29.190)  | 113                  | 16 kHz (see RFC4867 [10])                  |
| CSData (Clear Mode pseudo-codec – see RFC 4040 [9]) | Without RTP redundancy (redundancy level = 1) (3GPP TS 48.008 and TS 48.020)   | 120                  | 8 kHz (see RFC 4040 [9])                   |
|   | With RTP redundancy (redundancy level = 2 or 3) (3GPP TS 48.008 and TS 48.020) See sub-clause 5.6 for the format description | 121                  | 8 kHz (see RFC 4040 [9] and RFC 2198 [11]) |

### 5.4.2.3 RTP Packetization Time

The RTP Packetization Time is not negotiated for AoIP, but set to a predefined fixed value, see TS 26.102 [20].

For compressed speech on the A-Interface the Packetization Time is identical to the Speech Frame length and that is 20ms for all 3GPP Codec Types.

For PCM-coded speech (ITU-T G.711, A-law and  $\mu$ -law) the Packetization Time is predefined to 20ms for AoIP.

For CSData the Packetization Time is predefined to 20ms, when no redundancy is used. In case of RTP Redundancy more than one consecutive data block are included in one RTP packet. But for each of these data blocks the Packetization Time is predefined to 20ms.

### 5.4.3 RTCP

RTCP (see RFC 3550 [5]) may be applied. The use of the RTCP protocol is optional.

A BSS/MGW may ignore incoming RTCP PDUs.

## 5.5 Transport with RTP multiplexing

### 5.5.1 Introduction

This sub-clause specifies an optional transport format for the A interface and IP transport that allows transporting several RTP payload PDUs of different user plane connections within one UDP/IP packet, and the corresponding backward compatible signalling extensions required to negotiate the use of this transport option. Use of this transport format saves bandwidth in the IP network (bandwidth gains for the Nb interface are evaluated in 3GPP TR 29.814 [8]).

Bandwidth saving is achieved by multiplexing several RTP payload PDUs within one UDP/IP packet. As an option, the RTP header may be compressed in addition. Two transport formats are specified accordingly.

As specified in sub-clause 5.5.3.1 RTP multiplexing shall not be applied if RTP redundancy has been negotiated.

## 5.5.2 RTP

### 5.5.2.1 Transport format for multiplexing without RTP header compression

Several RTP payload PDUs sent to the same IP address are multiplexed within one single UDP/IP packet over the A interface. If DiffServ is applied, all multiplexed PDUs also need to share the same DiffServ class. The multiplexing shall only be used with RTP packets. RTCP shall be transported normally by UDP/IP packets.

Use of multiplexing shall be negotiated between BSS and MGW, as specified in sub-clause 5.5.3.2.

Before each multiplexed RTP/codecs payload PDU inserted into the UDP/IP packet a "Multiplex Header", which identifies the multiplexed packet, shall be inserted.

| Bits  |   |   |   |   |   |   |   | Number of Octets |                           |
|---|---|---|---|---|---|---|---|------------------|---------------------------|
| 7   | 6   | 5 | 4 | 3 | 2 | 1 | 0 |                  |                           |
| Source IP, Dest IP, ...                         |   |   |   |   |   |   |   | 20/40            | IP                        |
| Source Port, Dest Port = <Mux UDP Port>, Length |   |   |   |   |   |   |   | 8                | UDP                       |
| T=0   | Mux ID =<br>(Destination UDP Port of non-multiplexed PDU) / 2 |   |   |   |   |   |   | 2                | Multiplex Header          |
| Length Indicator (LI) = n                       |   |   |   |   |   |   |   |                  |                           |
| R   | Source ID =<br>(Source UDP Port of non-multiplexed PDU) / 2   |   |   |   |   |   |   | 2                | Multiplex Header          |
| Full RTP packet                                 |   |   |   |   |   |   |   |                  |                           |
| Full RTP packet                                 |   |   |   |   |   |   |   | n                | RTP header<br>RTP Payload |
| Multiplex Header                                |   |   |   |   |   |   |   | 5                | Multiplex Header          |
| Full RTP packet                                 |   |   |   |   |   |   |   | m                | RTP Header<br>RTP Payload |
| ...   |   |   |   |   |   |   |   |                  |                           |

**Figure 5.5.2.1.1: UDP/IP Packet with multiplexed RTP payload PDUs without RTP header compression**

The Multiplex Header includes:

- T bit.

The field has two possible values, 0 for indicating full packet and 1 for indicating compressed packet. Value 0 shall be used for an uncompressed RTP header, as described in the present sub-clause.

- Mux ID, 15 bits.

For identification of different user plane connections. The value shall be the UDP destination port of the corresponding non-multiplexed RTP packet divided by two (only even numbered ports are used for RTP sessions).

- Length Indicator (LI), 8 bits, unsigned integer.

Gives the length of the multiplexed RTP PDU packet (RTP header + RTP Payload) in bytes (the last byte of the RTP PDU is padded to the next byte boundary if necessary). Maximum length is 255 bytes. This LI allows calculating where the next Multiplex Header for the next multiplexed RTP PDU packet starts.

- R bit.

Reserved for future use. Shall be set to 0 by the sending entity and be ignored by the receiving entity.

- Source ID, 15 bits.

For identification of the different connections. The value shall be the source UDP port of the corresponding non-multiplexed RTP PDU packet divided by two (only even numbered ports are used for RTP sessions). This

information is transferred to permit the receiving node to optionally detect and filter illegitimate packets (e.g. packets received from the peer termination previously associated to the receiving termination).

The multiplexed RTP payload PDU shall be inserted in the IP/UDP packet directly after the corresponding Multiplex Header. The multiplexed RTP payload PDU shall consist of the full RTP header and the RTP payload. If the multiplexed RTP payload PDU does not end at a byte boundary, then the remaining bits of its last byte shall be padded with zeros.

### 5.5.2.2 Transport format for multiplexing with RTP header compression

To achieve even better bandwidth savings, the RTP header may optionally be compressed. This is possible since the RTP header includes many static fields that remain unchanged during an RTP session (see sub-clause 5.4.2.).

Use of RTP header compression shall be negotiated between BSS and MGW, as specified in sub-clause 5.5.3.2.

At least the first two RTP packets of each RTP session shall be sent with their full RTP header to allow the receiver to store the full header and use it in decompression. RTP packets shall also be sent with their full RTP header till receipt of a RTCP packet from the peer indicating support of RTP header compression. Subsequent packets may be sent with a compressed RTP header. If a BSS/MGW does not receive any of the initial RTP packets with a full RTP header, the BSS/MGW shall assume that the fields of the RTP header other than those present in the compressed RTP header are set as defined in sub-clause 5.4.2, and shall therefore not consider this as an error.

Before each multiplexed RTP payload PDU inserted into the UDP/IP packet a Multiplex Header, which identifies the multiplexed packet, shall be inserted

| Bits   |   |   |   |   |   |   | Number of Octets |                       |
|--|---|---|---|---|---|---|------------------|-----------------------|
| 7  | 6   | 5 | 4 | 3 | 2 | 1 |                  |                       |
| Source IP, Dest IP, ...                            |   |   |   |   |   |   | 20/40            | IP                    |
| Source Port, Dest Port=<MUX UDP Port>, Length, ... |   |   |   |   |   |   | 8                | UDP                   |
| T=1  | Mux ID =<br>(Destination UDP Port of non-multiplexed PDU) / 2 |   |   |   |   |   | 2                | Multiplex Header      |
|  | Length Indicator (LI) = n + 4                                 |   |   |   |   |   | 1                |                       |
| R  | Source ID =<br>(Source UDP Port of non-multiplexed PDU) / 2   |   |   |   |   |   | 2                |                       |
| Sequence Number (SN)                               |   |   |   |   |   |   | 1                | Compressed RTP header |
| Timestamp (TS)                                     |   |   |   |   |   |   | 2                |                       |
| M  | Payload Type (PT)   |   |   |   |   |   | 1                |                       |
| RTP payload  |   |   |   |   |   |   | n                | RTP Payload           |
| Multiplex Header                                   |   |   |   |   |   |   | 5                | Multiplex Header      |
| Compressed RTP header                              |   |   |   |   |   |   | 4                | Compressed RTP header |
| RTP payload  |   |   |   |   |   |   | m                | RTP payload           |
| ...  |   |   |   |   |   |   |                  |                       |

**Figure 5.5.2.2.1: UDP/IP Packet with multiplexed RTP payload PDUs with RTP header compression**

The Multiplex Header shall be used as described in sub-clause 5.4.3.2. However, the T bit shall be set for a compressed RTP header, as described in the present sub-clause. The Length Indicator gives the length of the multiplexed RTP PDU packet in bytes (compressed RTP header + RTP Payload).

The multiplexed RTP payload PDU shall be inserted in the IP/UDP packet directly after the corresponding Multiplex Header. The multiplexed RTP payload PDU shall consist of the compressed RTP header described below followed by the full RTP payload, as for sub-clause 5.4.2.1. If the multiplexed RTP payload PDU does not end at a byte boundary, then the remaining bits of its last byte shall be padded with zeros.

The compressed RTP header shall include the following fields taken from the uncompressed RTP header:

- Sequence number (SN), 8 bits.

The field is the least significant byte of the original RTP sequence number (RFC 3550 [29]), hence the sequence number is shortened from 16 bits to 8 bits (which allows to identify 256 consecutive packets). Sub-clause 5.4.2.1.7 is applicable.

- Timestamp (TS), 16 bits.

The TS field is the two least significant bytes of the original RTP timestamp (RFC 3550 [5]), hence the length is half of the original resulting in modulo of 8 seconds (resp 4 seconds) with 8 kHz (resp 16 kHz) clock reference. Sub-clause 5.4.2.1.8 is applicable.

- Marker bit, 1 bit (see sub-clause 5.4.2)
- Payload Type, 7 bits (see sub-clause 5.4.2)

NOTE: These RTP fields may change during a connection and thus need to be transferred within each packet for RTP payload. All other RTP fields do not change (see sub-clause 5.4.2).

## 5.5.3 RTCP

### 5.5.3.1 General

A BSS/MGW wishing to apply RTP multiplexing shall use RTCP (see RFC 3550 [5]) to negotiate multiplexing.

RTCP shall be used separately for each user plane connection. RTCP shall be transported by UDP/IP packets as described in sub-clause 5.4.3. and not included in IP/UDP packets using the multiplexing format described above.

Multiplexing negotiation shall not be performed for user plane connections for which RTP redundancy is used.

### 5.5.3.2 Multiplexing negotiation via RTCP

RTCP shall be used to negotiate the use of multiplexing. A 3GPP-specific RTCP Multiplexing packet is specified in sub-clause 5.5.3.3. for this purpose, and may be sent as a non-compound RTCP packet. It may also be added to compound RTCP packets following the principles of RFC 3550 [5]. The Multiplexing RTCP packet indicates:

- if multiplexing without RTP header compression is supported ;
- if multiplexing with RTP header compression is supported ;
- the local UDP port where to receive multiplexed data streams,
- if multiplexing is selected.

When setting up a new user plane connection, both peer BSS and MGW of an UP connection shall start to send data without applying multiplexing and may indicate their readiness to receive multiplexed data streams by including the new RTCP Multiplexing packet in the initial and all subsequent RTCP packets they send. A BSS/MGW shall always announce the same multiplexing capabilities and the same UDP port where to receive multiplexed data streams in all the RTCP Multiplexing packets it sends for a given RTP session. BSS/MGW should preferably send their initial RTCP packet at the very beginning of the RTP session to be able to apply multiplexing as soon as possible, and may repeat it with shorter interval than regular RTCP transmission interval in the beginning to provide resilience against packet loss. A BSS/MGW sending a Multiplexing packet indicating support of multiplexing shall be ready to receive multiplexed packets at the announced UDP port. A single UDP port for multiplexing shall be used per destination IP address.

A BSS/MGW receiving an RTCP packet, where the peer indicated its readiness to receive multiplexed data streams, may apply multiplexing to send the corresponding RTP data streams towards the sender of the RTCP packet. If the BSS/MGW decides to apply multiplexing, it can immediately start sending multiplexed data streams towards the corresponding UDP multiplexing port announced in the received RTCP Multiplexing packet. The BSS/MGW shall indicate in subsequent RTCP Multiplexing packets if it applies multiplexing with or without header compression for the given user connection

A BSS/MGW that does not receive RTCP or receives RTCP without the RTCP Multiplexing packet shall continue to send data for the user connection without applying multiplexing.

A BSS/MGW that does not support multiplexing will ignore the unknown received RTCP Multiplexing packet according to RTCP procedures and will continue to send data for the user connection without applying multiplexing.

Sending of a RTCP Multiplexing packet indicating readiness to receive multiplexed data streams does not necessarily mean that the BSS/MGW is ready to send multiplexed data streams, i.e. multiplexing may be applied on a single or on both directions for a given RTP session.

### 5.5.3.3 RTCP Multiplexing packet

The format of the RTCP Multiplexing packet is specified in figure 5.5.3.3.1.

| Bits              |    |                       |         |               |   |   |   | Number of Octets |                            |
|-------------------|----|-----------------------|---------|---------------|---|---|---|------------------|----------------------------|
| 7                 | 6  | 5                     | 4       | 3             | 2 | 1 | 0 |                  |                            |
| V=2               |    | P                     | subtype |               |   |   |   | 1                | APP packet header          |
| PT=APP=204        |    |                       |         |               |   |   |   | 1                |                            |
| Length            |    |                       |         |               |   |   |   | 2                |                            |
| SSRC/CSRC         |    |                       |         |               |   |   |   | 4                |                            |
| Name(ASCII)       |    |                       |         |               |   |   |   | 4                |                            |
| MUX               | CP | Selection             |         | Reserved=0000 |   |   |   | 2                | Application dependent data |
| Reserved=00000000 |    |                       |         |               |   |   |   |                  |                            |
| Reserved=0        |    | Local MUX UDP port /2 |         |               |   |   |   | 2                |                            |

**Figure 5.5.3.3.1: RTCP Multiplexing packet**

The APP packet header includes :

- version (V), 2 bits

Identifies the version of RTP, which is the same in RTCP packets as in RTP data packets. RTP Version 2 shall be used.

- padding (P), 1 bit

As specified in RFC 3550 [4].

- subtype, 5 bits.

The following subtype value shall be used :

00001 : RTCP Multiplexing packet

- packet type (PT), 8 bits.

Shall contains the constant 204 to identify this as an RTCP APP packet

- length, 16 bits.

As specified in RFC 3550 [4]. The length of this RTCP packet in 32-bit words minus one, including the header and any padding. (The offset of one makes zero a valid length and avoids a possible infinite loop in scanning a compound RTCP packet, while counting 32-bit words avoids a validity check for a multiple of 4.)

- SSRC/CSRC, 32 bits.

As specified in RFC 3550 [4].

- name, 32 bits.

Shall be set to "3GPP"

The application-dependent data includes :

- multiplexing bit (MUX), 1 bit

Indicates whether multiplexing without RTP header compression is supported or not by the sender of the RTCP packet : set to 0 if not supported, set to 1 if supported.

- multiplexing with RTP header compression bit (CP), 1 bit

Indicates whether multiplexing with RTP header compression is supported or not by the sender of the RTCP packet : set to 0 if not supported, set to 1 if supported.

- Selection bits, 2 bits

Indicates whether the sender of the RTCP packet has selected to apply multiplexing with or without header compression for the user plane packets that it sends on this connection. The following values are defined:

00: no multiplexing is applied

01: multiplexing is applied without RTP header compression

10: multiplexing is applied with RTP header compression

11: reserved

- Local MUX UDP port, 15 bits :

Local UDP port where the sender demands to receive multiplexed data streams. The value shall be the same as the local MUX UDP port divided by two. This parameter shall be ignored by the receiver of the RTCP Multiplexing packet if the MUX and CP bits indicate that multiplexing is not supported.

- Reserved bits:

Extension bits may be added in the RTCP Multiplexing packet in future releases. Reserved bits shall be set to 0 in sent RTCP Multiplexing packet of this release and shall be ignored in incoming RTCP Multiplexing packets.

Extension fields may be added in the RTCP Multiplexing packet in future releases. They shall be ignored by a BSS/MGW implementing an earlier version of the specification.

## 5.6 Transport of CSData

### 5.6.1 Introduction

The transport of Circuit Switched Data (CSData) across the A-Interface User Plane over IP uses per default no redundancy. A constant bit stream of 64kbps is transported in RTP packets, one every 20ms, with 160 octets payload each. RFC 4040 [9] is used as basis. It is expected that most IP networks provide a sufficiently low RTP packet loss rate and redundancy is not needed, because the errors introduced by the imperfect radio transmission dominate the service performance by far.

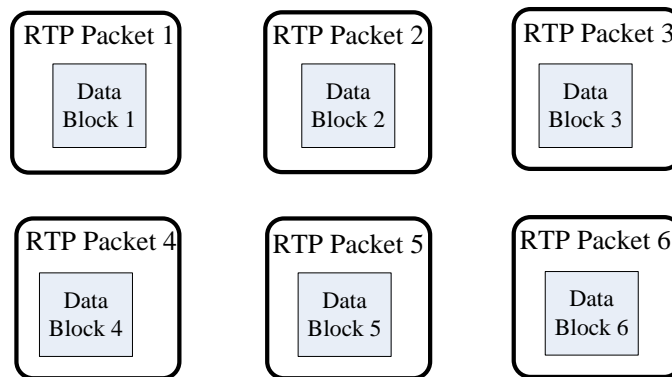

**Figure 5.6.1.1: No Redundancy (redundancy level = 1)**

RTP redundancy may be used for CSData calls in AoIP in networks with noticeable RTP packet losses in order to reduce the data loss rate and improve the success rate of sensitive CSData services (e.g. fax). RTP redundancy increases the transmission delay noticeably and the bandwidth demand across the A-Interface substantially. RTP redundancy shall not be used for speech calls on AoIP. RFC 2198 [11] is used as basis.

RTP redundancy increases the size of RTP packets substantially and is therefore not compatible with RTP multiplexing. On the other hand RTP Multiplexing would not gain much due to the already low overhead caused by this packet size.

RTP redundancy for CSData is negotiated per call between MSC and BSS in BSSMAP, see TS 48.008 [19]. RTP redundancy is always used symmetrically, i.e. the same redundancy level is used in both directions across the A-Interface for a given call. The negotiated RTP redundancy is exactly known to sender and receiver in AoIP.

For RTP redundancy, several successive data blocks are usually packed (except for start and stop) into one RTP packet. The number of RTP packets is not increased (or only marginally due to start/stop effects). The normal number of successive data blocks in one RTP packet is defined as "redundancy level". Redundancy level 1 denotes the transmission without redundancy (Figure 5.6.1.1).

When RTP redundancy is used, the redundancy level can be either 2 (Figure 5.6.1.2) or 3 (Figure 5.6.1.3).

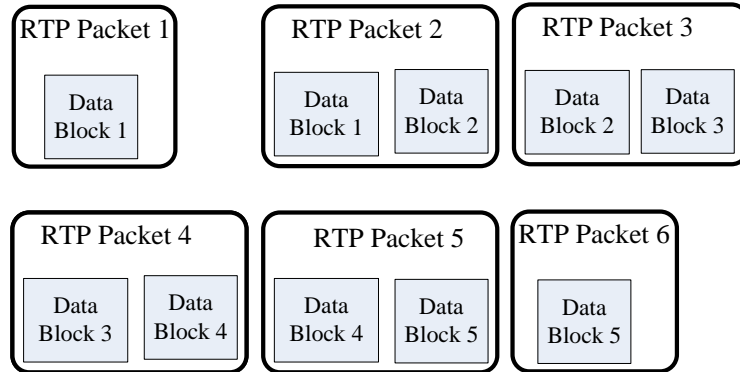

**Figure 5.6.1.2: RTP packets with redundant data with redundancy level = 2**

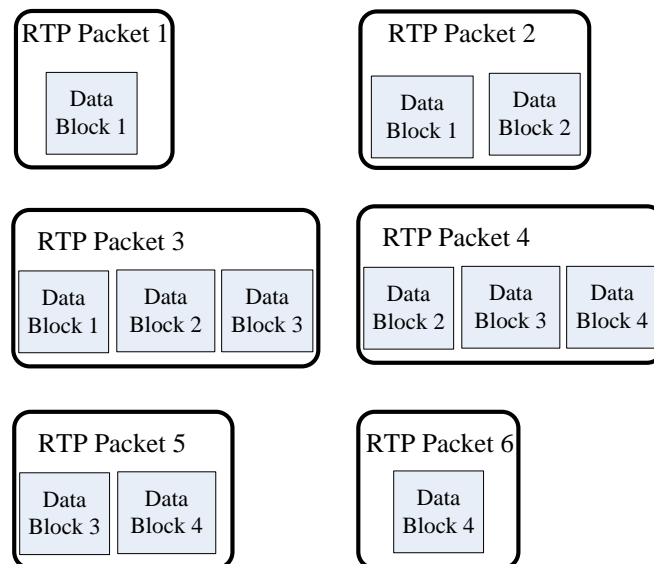

**Figure 5.6.1.3: RTP packets with redundant data with redundancy level = 3**

Each RTP packet with redundancy consists of the "primary" data block and one or two "redundant" data blocks. The Time Stamp of the RTP packet is identical to the Time Stamp of the primary data block. The redundant data blocks have Time Stamp values lower than the primary data block (except when wrap around of timestamp occurs). Note that also RTP packets without redundant data blocks are used in start and stop, when redundancy has been negotiated.

## 5.6.2 Transport formats for CSData

### 5.6.2.1 Transport format for CSData without redundancy

If RTP redundancy is not used, then RTP multiplexing may be applied. The following text describes the RTP packet format for CSData on AoIP without RTP multiplexing.

The RTP packet format for CSData is defined in RFC 4040 [9]). For AoIP the RTP Payload Type "120" identifies this RTP Packet as "RTP packet without redundancy". The RTP sequence number is "n". It is incremented by the sender by 1 with every newly sent RTP packet, regardless of the Time Stamp.



The Time Stamp of the RTP Packet is "Tn". It is incremented by the sender as appropriate. Since for AoIP the Packetization Time is fixed to 20ms and the Sampling Clock is fixed to 8000, the Time Stamp is incremented typically by 160.

Due to the fixed Packetization time and Sampling Clock one data block in CSData for AoIP has 160 octets (O1 to O160). The length of the data block is not explicitly given within the RTP packet; it can be derived from the size of the RTP packet minus the overhead (12 octets).

Here the example for one RTP packet for CSData in AoIP with no redundancy (4 octets in one row):

| Octet 1 (5, 9, ...)                      |   |   |                   | Octet 2 (6, 10, ...) |          | Octet 3 (7, 11, ...)                     |  | Octet 4 (8, 12, ...) |  |
|--|---|---|-------------------|----------------------|----------|--|--|----------------------|--|
| V=2                                      | P | X | CC=0              | M                    | PT = 120 | Sequence number of primary data block: n |  |                      |  |
| Time Stamp of primary data block: Tn     |   |   |                   |                      |          |  |  |                      |  |
| Synchronisation Source Identifier (SSRC) |   |   |                   |                      |          |  |  |                      |  |
| O1 of CSData (primary=Tn)                |   |   | O2 of CSData (Tn) |                      |          | O3 of CSData (Tn)                        |  | O4 of CSData (Tn)    |  |
| ...                                      |   |   | ...               |                      |          | ...                                      |  | ...                  |  |
| ...                                      |   |   | ...               |                      |          | ...                                      |  | O160 of CSData (Tn)  |  |

Figure 5.6.2.1.1: RTP packetisation for CSData without redundancy

### 5.6.2.2 Transport format for CSData with redundancy

If RTP redundancy is used, then RTP multiplexing shall not be applied. When RTP redundancy is used (redundancy level = 2 or 3) the RTP packet format is further defined in RFC 2198 [11]).

The RTP Payload Type of "121" in AoIP identifies this RTP packet as "RTP packet with redundancy".

RFC 2198 introduces just after the main RTP header (first 12 octets) a sub-header as (example RED=3):

| Octet 1 (5, 9) |                      | Octet 2 (6)                           |  | Octet 3 (7)              |  | Octet 4 (8) |  |
|----------------|----------------------|---------------------------------------|--|--------------------------|--|-------------|--|
| F=1            | Block-PT (n-2) = 120 | Timestamp-offset of block (n-2) = 320 |  | Block-length (n-2) = 160 |  |             |  |
| F=1            | Block-PT (n-1) = 120 | Timestamp-offset of block (n-1) = 160 |  | Block-length (n-1) = 160 |  |             |  |
| F=0            | Block-PT (n) = 120   |                                       |  |                          |  |             |  |

Figure 5.6.2.2.1: RTP sub-header for CSData with redundancy

This sub-header includes:

**F bit:** 1 bit; set to  
1, if this is a redundant data block and another data block follows  
0, if this is the last (primary) data block

**Block-Payload Type:** 7 bits; set to 120 in case of CSData on AoIP.

**Timestamp-Offset:** 14 bits;  
unsigned integer; specifies the offset with respect to the (main) Time Stamp of the RTP packet.  
It allows to compute the actual timestamp of the corresponding redundant data block, which equals  
Time Stamp (data block) = Timestamp (RTP packet) – Timestamp-Offset (data block).

**Block Length:** 10 bits  
unsigned integer; specifies the size of the data block in octets.

The Block-Payload Type ("120" for AoIP) identifies that the primary and redundant data are packed according to RFC 4040, see above, as specified for AoIP. The Time Stamp of the RTP Packet is identical to the Time Stamp of the primary data block (n), which comes last in the RTP packet. The redundant data block (n-1), which comes before the primary data block, has 160 octets, its Time Stamp (Tn-160) is defined relative to the Time Stamp of the primary data block, i.e. Timestamp-offset = 160. The block-length of the redundant data (n-1) block is specified.

The length of the primary data block is not explicitly included, it can be derived from the size of the RTP packet minus the overhead minus the size of the redundant data blocks.

Here the example for one RTP packet with RED=2:

| Octet 1 (5, 9, ...)                      |                |   |      | Octet 2 (6, 10, ...)                |               | Octet 3 (7, 11, ...)                     |                          | Octet 4 (8, 12, ...)       |  |
|--|----------------|---|------|-------------------------------------|---------------|--|--------------------------|----------------------------|--|
| V=2                                      | P              | X | CC=0 | M                                   | Main-PT = 121 | Sequence number of primary data block: n |                          |                            |  |
| Time Stamp of primary data block: Tn     |                |   |      |                                     |               |  |                          |                            |  |
| Synchronisation Source Identifier (SSRC) |                |   |      |                                     |               |  |                          |                            |  |
| 1  | Block-PT = 120 |   |      | Timestamp-offset of block n-1 = 160 |               |  | Block-length (n-1) = 160 |                            |  |
| 0  | Block-PT = 120 |   |      | O1 of CSDData (red=Tn-160)          |               | O2 of CSDData (red=Tn-160)               |                          | O3 of CSDData (red=Tn-160) |  |
| ...                                      |                |   |      |                                     |               |  |                          |                            |  |
| O160 of CSDData (red=Tn-160)             |                |   |      | O1 of CSDData (prim=Tn)             |               | ...                                      |                          | ...                        |  |
| ...                                      |                |   |      |                                     |               |  |                          |                            |  |
| O160 of CSDData (Tn)                     |                |   |      |                                     |               |  |                          |                            |  |

**Figure 5.6.2.2: RTP packetisation for CSDData with redundancy RED=2**

Here the example for one RTP packet with RED=3:

| Octet 1 (5, 9, ...)                      |                |   |      | Octet 2 (6, 10, ...)                |               | Octet 3 (7, 11, ...)                     |                          | Octet 4 (8, 12, ...)       |  |
|--|----------------|---|------|-------------------------------------|---------------|--|--------------------------|----------------------------|--|
| V=2                                      | P              | X | CC=0 | M                                   | Main-PT = 121 | Sequence number of primary data block: n |                          |                            |  |
| Time Stamp of primary data block: Tn     |                |   |      |                                     |               |  |                          |                            |  |
| Synchronisation Source Identifier (SSRC) |                |   |      |                                     |               |  |                          |                            |  |
| 1  | Block-PT = 120 |   |      | Timestamp offset of block n-2 = 320 |               |  | Block-length (n-2) = 160 |                            |  |
| 1  | Block-PT = 120 |   |      | Timestamp offset of block n-1 = 160 |               |  | Block-length (n-1) = 160 |                            |  |
| 0  | Block-PT = 120 |   |      | O1 of CSDData (red=Tn-320)          |               | O2 of CSDData (red=Tn-320)               |                          | O3 of CSDData (red=Tn-320) |  |
| ...                                      |                |   |      |                                     |               |  |                          |                            |  |
| O160 of CSDData (Tn-320)                 |                |   |      | O1 of CSDData (red=Tn-160)          |               | ...                                      |                          | ...                        |  |
| ...                                      |                |   |      |                                     |               |  |                          |                            |  |
| O160 of CSDData (Tn-160)                 |                |   |      | O1 of CSDData (prim=Tn)             |               | ...                                      |                          | ...                        |  |
| ...                                      |                |   |      |                                     |               |  |                          |                            |  |
| O160 of CSDData (Tn)                     |                |   |      |                                     |               |  |                          |                            |  |

**Figure 5.6.2.3: RTP packetisation for CSDData with redundancy RED=3**

### 5.6.2.3 Start and Stop of RTP streams with redundancy

For the first RTP packet in a stream of RTP packets with redundancy only one data block exists: the primary data block. Therefore this first RTP packet looks like:

| Octet 1 (5, 9, ...)                      |                |   |      | Octet 2 (6, 10, ...)    |               | Octet 3 (7, 11, ...)                     |  | Octet 4 (8, 12, ...) |  |
|--|----------------|---|------|-------------------------|---------------|--|--|----------------------|--|
| V=2                                      | P              | X | CC=0 | M                       | Main-PT = 121 | Sequence number of primary data block: n |  |                      |  |
| Time Stamp of primary data block: Tn     |                |   |      |                         |               |  |  |                      |  |
| Synchronisation Source Identifier (SSRC) |                |   |      |                         |               |  |  |                      |  |
| 0  | Block-PT = 120 |   |      | O1 of CSDData (prim=Tn) |               | O2 of CSDData (Tn)                       |  | O3 of CSDData (Tn)   |  |
| ...                                      |                |   |      |                         |               |  |  |                      |  |
| O160 of CSDData (Tn)                     |                |   |      |                         |               |  |  |                      |  |

**Figure 5.6.2.3.1: RTP packetisation for CSDData with redundancy RED=3**

The (main-) Payload Type of the RTP Packet is set to "121" to indicate the redundancy. But the sub-header specifies only one data block with Payload Type "120" and no further redundant data blocks. So this RTP packet is different to the one for no redundancy, although only one data block is included. The second RTP packet looks always like shown in the example above for RED=2. If RED=2 is negotiated, then all following RTP packets are identical in design to the second one. If RED=3 is negotiated, then the third and all following RTP packets look like shown in the example above for RED=3. Since the primary data block is always the last in the RTP packet and is defining the Time Stamp for the RTP packet, this Time Stamp is always incrementing by 160.

For the last RTP packets in a stream of RTP packets with redundancy the packet content is again reduced from 3 to 2 to 1 data block and so the very last RTP packet is designed like the very first one, then last-1 like the second and the last-2 like the third. But at the end no new primary data blocks are added, the last block in the RTP packet is then already a redundant data block and therefore the Time Stamp of the RTP packet does not longer increment (but the RTP sequence number does increment).

The start of the RTP stream is important at call setup and handover. The end of the RTP stream is important at handover, maybe less important at the end of the call.

## 5.7 Transport during local switching

When a local switch path is established in the BSS for a local call, the UDP/IP endpoints at the BSS and the Access MGWs for both the call legs in uplink and downlink shall not be released.

---

### Annex A (informative): Change history

| Date / TSG     | TSG Doc. | CR | Rev | Subject/Comment                              | New    |
|----------------|----------|----|-----|--|--------|
| September 2012 |          |    |     | Update to version 11 based on version 10.0.0 | 11.0.0 |