

3GPP TS 48.006 V11.0.0 (2012-09)

Technical Specification

**3rd Generation Partnership Project;
Technical Specification Group GSM/EDGE Radio Access Network;
Signalling transport mechanism specification for the
Base Station System - Mobile-services Switching Centre
(BSS - MSC) interface
(Release 11)**



The present document has been developed within the 3rd Generation Partnership Project (3GPP™) and may be further elaborated for the purposes of 3GPP. The present document has not been subject to any approval process by the 3GPP Organisational Partners and shall not be implemented. This Specification is provided for future development work within 3GPP only. The Organisational Partners accept no liability for any use of this Specification. Specifications and reports for implementation of the 3GPP™ system should be obtained via the 3GPP Organisational Partners' Publications Offices.

Keywords

GSM, radio

3GPP

Postal address

3GPP support office address

650 Route des Lucioles - Sophia Antipolis
Valbonne - FRANCE
Tel.: +33 4 92 94 42 00 Fax: +33 4 93 65 47 16

Internet

<http://www.3gpp.org>

Copyright Notification

No part may be reproduced except as authorized by written permission.
The copyright and the foregoing restriction extend to reproduction in all media.

© 2012, 3GPP Organizational Partners (ARIB, ATIS, CCSA, ETSI, TTA, TTC).
All rights reserved.

UMTS™ is a Trade Mark of ETSI registered for the benefit of its members
3GPP™ is a Trade Mark of ETSI registered for the benefit of its Members and of the 3GPP Organizational Partners
LTE™ is a Trade Mark of ETSI currently being registered for the benefit of its Members and of the 3GPP Organizational Partners
GSM® and the GSM logo are registered and owned by the GSM Association

Contents

Foreword	5
1 Scope	6
2 References.....	6
3 Definitions and abbreviations	9
3.1 Definitions	9
3.2 Abbreviations.....	9
4 Field of application	9
5 Functional content.....	9
6 Message transfer part (MTP) functions	10
6.1 General	10
6.2 Level 1	10
6.2.1 E1 link (ITU-T Recommendation Q.702).....	10
6.2.2 T1 link (ANSI Specification T1.111.2)	11
6.3 Level 2.....	11
6.3.1 E1 link (ITU-T Recommendation Q.703).....	11
6.3.2 T1 link (ANSI Specification T1.111.3)	12
6.4 Level 3	12
6.4.1 E1 link (ITU-T Recommendation Q.704).....	12
6.4.2 T1 link (ANSI Specification T1.111.4)	16
6.5 Testing and Maintenance	19
6.5.1 E1 link (ITU-T Recommendation Q.707).....	19
6.5.2 T1 link (ANSI Specification T1.111.7)	19
6a Message Transfer Part 3 (MTP3) – User Adaptation Layer (M3UA) functions	20
6a.1 Introduction	20
6a.2 Protocol Stack	20
6a.3 Data Link Layer	21
7 Interface functions.....	21
8 SCCP functions.....	21
8.1 Overview	21
8.2 Primitives	22
8.2.1 E1 link (ITU-T Recommendation Q.711).....	22
8.2.2 T1 link (ANSI Specification T1.112.1).....	22
8.3 SCCP messages.....	23
8.3.1 E1 link (ITU-T Recommendation Q.712).....	23
8.3.2 T1 link (ANSI Specification T1.112.2)	24
8.4 SCCP formats and codes.....	25
8.4.1 E1 link (ITU-T Recommendation Q.713).....	25
8.4.2 T1 link (ANSI Specification T1.112.3)	26
8.5 SCCP procedures.....	26
8.5.1 E1 link (ITU-T Recommendation Q.714).....	26
8.5.2 T1 link (ANSI Specification T1.112.4)	28
9 Use of the SCCP	29
9.1 Connection establishment	29
9.1.1 Establishment procedure in case i).....	31
9.1.2 Establishment procedure in case ii).....	31
9.1.3 Establishment procedure in case iii)	31
9.1.4 Establishment procedure in case iv).....	32
9.2 Connection release	32
9.3 Transfer of DTAP and BSSMAP data	32
9.3.1 Distribution function.....	32
9.3.1.1 ITU-T Recommendation.....	32

9.3.1.2	ANSI Specification.....	33
9.3.2	Transfer of DTAP messages	33
9.3.3	Transfer of BSSMAP messages.....	34
9.4	Connectionless services.....	34
9.4.1	Discrimination parameter (ITU-T Recommendation)	34
9.4.2	Discrimination parameter (ANSI Specification)	35
9.4.3	User Data Field Structure	35
10	Use of the SCCP for operations and maintenance	35
10.1	Connectionless service	35
10.2	Connection oriented services.....	36
10.3	BSS failure.....	36
Annex A (informative):	Change History.....	37

Foreword

This Technical Specification has been produced by the 3rd Generation Partnership Project (3GPP).

The contents of the present document are subject to continuing work within the TSG and may change following formal TSG approval. Should the TSG modify the contents of the present document, it will be re-released by the TSG with an identifying change of release date and an increase in version number as follows:

Version x.y.z

where:

- x the first digit:
 - 1 presented to TSG for information;
 - 2 presented to TSG for approval;
 - 3 or greater indicates TSG approved document under change control.
- y the second digit is incremented for all changes of substance, i.e. technical enhancements, corrections, updates, etc.
- z the third digit is incremented when editorial only changes have been incorporated in the document.

1 Scope

The present document is split into four parts, clauses 4 to 6 dealing with the MTP, clause 6a dealing with M3UA/SCTP, clause 7 dealing with interface functions towards higher layers and clauses 8 to 10 dealing with the SCCP and its use.

The MTP provides a mechanism giving reliable transfer of signalling messages. Clauses 4 to 7 of the present document deal with the subset of the MTP that can be used between an BSS and an MSC, which is compatible with a full MTP.

The M3UA/SCTP provides a mechanism giving reliable transfer of signalling messages over an IP network.

The SCCP is used to provide a referencing mechanism to identify a particular transaction relating to for instance a particular call. Clauses 8 to 10 identify the SCCP subset that should be used between a BSS and an MSC. The SCCP can also be used to enhance the message routing for (for instance) operations and maintenance information.

2 References

The following documents contain provisions which, through reference in this text, constitute provisions of the present document.

- References are either specific (identified by date of publication, edition number, version number, etc.) or non-specific.
- For a specific reference, subsequent revisions do not apply.
- For a non-specific reference, the latest version applies. In the case of a reference to a 3GPP document (including a GSM document), a non-specific reference implicitly refers to the latest version of that document *in the same Release as the present document*.

[1]	3GPP TR 21.905: "Vocabulary for 3GPP Specifications".
[2]	Void.
[3]	Void.
[4]	Void.
[5]	Void.
[6]	Void.
[7]	Void.
[8]	Void.
[9]	Void.
[10]	Void.
[11]	Void.
[12]	Void.
[13]	Void.
[14]	Void.
[15]	Void.
[16]	Void.
[17]	Void.
[18]	Void.

- [19] Void.
- [20] Void.
- [21] Void.
- [22] Void.
- [23] Void.
- [24] Void.
- [25] Void.
- [26] Void.
- [27] Void.
- [28] 3GPP TS 44.006: "Mobile Station - Base Station System (MS - BSS) interface Data Link (DL) layer specification".
- [29] Void.
- [30] 3GPP TS 44.018: "Mobile radio interface layer 3 specification; Radio Resource Control Protocol".
- [31] Void.
- [32] Void.
- [33] Void.
- [34] Void.
- [35] Void.
- [36] Void.
- [37] Void.
- [38] Void.
- [39] Void.
- [40] Void.
- [41] Void.
- [42] Void.
- [43] Void.
- [44] Void.
- [45] Void.
- [46] 3GPP TS 48.008: "Mobile Switching Centre – Base Station System (MSC-BSS) interface; Layer 3 specification".
- [47] Void.
- [48] Void.
- [49] Void.
- [50] Void.
- [51] Void.
- [52] Void.

- [53] Void.
- [54] Void.
- [55] Void.
- [56] Void.
- [57] Void.
- [58] ITU-T Recommendation Q.702: "Signalling data link".
- [59] ITU-T Recommendation Q.703: "Signalling link".
- [60] ITU-T Recommendation Q.704: "Signalling network functions and messages".
- [61] ITU-T Recommendation Q.707: "Testing and maintenance".
- [62] ITU-T Recommendation Q.711: "Functional description of the signalling connection control part".
- [63] ITU-T Recommendation Q.712: "Definition and function of signalling connection control part messages".
- [64] ITU-T Recommendation Q.713: "Signalling connection control part formats and codes".
- [65] ITU-T Recommendation Q.714: "Signalling connection control part procedures".
- [66] 3GPP TS 23.003: "Numbering, addressing and identification".
- [67] ANSI T1.110-1999: "Signaling System No.7; General Information".
- [68] ANSI T1.111-2000: "Signalling System No. 7; Message Transfer Part".
- [69] ANSI T1.112-1996: "Signalling System No. 7; Signalling Connection Control Part Functional Description".
- [70] TIA/EIA/IS-104-A: "Personal Communications Service Descriptions for 1 800 MHz".
- [71] ITU-T Recommendation Q.701: "Functional description of the message transfer part (MTP) of Signalling System No. 7".
- [72] IETF RFC 2960(10/2000): "Stream Control Transmission Protocol".
- [73] IETF RFC 3332(09/2002): "Signalling System 7 (SS7) Message Transfer Part 3 (MTP3) – User Adaptation Layer (M3UA)".
- [74] IETF STD 51, RFC 1661(07/1994): "The Point-To-Point Protocol (PPP)".
- [75] IETF STD 51, RFC 1662(07/1994): "PPP in HDLC-like Framing".
- [76] IETF RFC 2507(02/1999): "IP header compression".
- [77] IETF RFC 1990(07/1994): "The PPP Multilink Protocol (MP)".
- [78] IETF RFC 2686(09/1999): "The Multi-Class Extension to Multi-Link PPP".
- [79] IETF RFC 2509(02/1999): "IP Header Compression over PPP".
- [80] IETF RFC 2474 (12/1998): "Definition of the Differentiated Services Field (DS Field) in the IPv4 and IPv6 Headers".
- [81] RFC 3309: "SCTP Checksum Change".
- [82] IETF RFC 791 (09/1981): "Internet Protocol".
- [83] IETF RFC 2460: "Internet Protocol, Version 6 (IPv6) Specification".
- [84] 3GPP TS 29.202: "SS7 Signalling Transport in Core Network; Stage 3"

3 Definitions and abbreviations

3.1 Definitions

For the purposes of the present document, the following terms and definitions apply:

E1: link employs 32 Pulse Code Modulation signals (timeslots) at 64 kbits/s. The 32 timeslots consist of 30 voice (or signalling) channels and 2 common signalling channels. The output bit rate is 2 048 Mbits/s.

T1: link employs 24 Pulse Code Modulation signals (timeslots) at 64 kbits/s. (T1 interface can alternatively use signalling at 56 kbits/s). The output bit rate is 1 544 Mbits/s. (A frame consists of 193 bits, $(8 \times 24) + 1$, as one bit is used for synchronization. The frame repeats 8,000 times per second.).

3.2 Abbreviations

For the purposes of the present document, the abbreviations given in 3GPP TR 21.905 apply.

4 Field of application

- a) The present document is applicable to the signalling between radio subsystems (BSS) and mobile switching centres (MSCs) in GSM PLMNs. It provides a minimum set of MTP, or in the case of IP-based signalling transport - M3UA and SCTP, requirements that may be implemented at a BSS or MSC, whilst maintaining compatibility with the implementation of a full specification of the MTP (M3UA/SCTP).
- b) For MTP signalling transport usage, the Technical Specification defines the interface at the 64 kbits/s boundary to the BSS or MSC and applies primarily for digital access arrangements, the use of analogue arrangements is an option for PLMN operator.

Also, the Technical Specification defines the interface at the 56 kbits/s boundary to the BSS or MSC for T1 links.
- c) The security of signalling links is a PLMN operator concern, however it is recommended that in the case where more than one multiplex system is required and security reasons dictate the use of a multiple link linkset, then each signalling link should be assigned in a different multiplex system. It is however noted that this is of little benefit if diversity of routing of the multiplexes is not used.
- d) Both associated and quasi-associated modes of signalling between the BSS and the MSC are allowed. In case of quasi-associated mode the STP functionality is provided outside the BSS. Future evolution or economic reasons applicable to the interface may however make the use of STP working at the BSS attractive, in which case some of the simplifications in this paper will not apply.
- e) A variety of information types may be supported by the signalling system, e.g. relating to circuit switched call control and packet communication. These are fully defined in the service series of Technical Specifications (the 3GPP TS 02.xx series and in [70] for PCS 1900).
- f) For E1 link usage, the ITU-T recommendations concerning the MTP shall be taken as being requirements unless covered by a statement in the present document.
- g) For T1 link usage, the ANSI recommendations concerning the MTP [68] shall be taken as being requirements unless covered by a statement in the present document.
- h) For IP-based signaling transport usage, 3GPP TS 29.202 [84] shall be taken as being requirements unless covered by a statement in the present document.

5 Functional content

The functional requirements are as follows:

- a) the network call control functions are as specified in 3GPP TS 48.008 and 3GPP TS 44.018;
- b) the minimum set of Message Transfer Part functions are specified in Blue Book ITU-T Recommendations Q.702, Q.703, Q.704 and Q.707, with the qualifications specified in the present document;

The functions are specified in ANSIT1.111 [68] for T1 links.

- c) the additional interface functions required for the proper operation of the layer 3 control functions in combination with the Message Transfer Part, or in the case of IP-based signalling transport - M3UA and SCTP, functions, are specified in clause 7 of the present document.
- d) the minimum set of Message Transfer Part 3 – User Adaptation (M3UA) functions are specified in 3GPP TS 29.202 [84].

6 Message transfer part (MTP) functions

6.1 General

For E1 links, the MTP functions as specified in ITU-T Recommendations Q.702, Q.703, Q.704 and Q.707 are applicable. For T1 links, the MTP functions as specified in ANSI specifications T1.110 clause 5, and T1.112 clause 5 are applicable. However, the following exceptions and modifications to those Recommendations may be applied for the MSC to BSS signalling, see clauses 6.2 to 6.4.

Some form of policing could be included at the MSC in order to ensure that no signalling messages received from the BSS can be routed further than the MSC if an administration requires. This is necessary to prevent fraudulent use of the signalling network for implementations of the GSM system. The manner in which this is achieved will be dependent on local agreements or regulations and system implementations.

Where load sharing is used, all messages to do with a given SCCP connection should be passed down a given link.

6.2 Level 1

6.2.1 E1 link (ITU-T Recommendation Q.702)

Q.702 figure 2

These figures should be treated as for information only. For the standard application of GSM, interface point C is appropriate.

Q.702 clause 4.4

The use of analogue circuits to support the signalling link is a national matter.

Q.702 clause 5

A signalling rate of 64 kbits/s is assumed. Lower rates (e.g. using analogue bearers) are a national concern.

Q.702 clause 6

Error characteristics and availability are a national concern. Care should be taken as excessive errors could lead to inefficient use of the signalling links.

Q.702 clause 8

The standard arrangement will be to derive the signalling link from a 2 048 kbits/s digital path.

Q.702 clause 9

Only digital signalling data links are relevant.

The use of analogue bearers to support this interface is considered a national concern. However it should be noted that there will be potential problems with the following areas:

- the signalling load may exceed that which can be carried by a single low rate analogue link, this may lead to an excessive number of signalling links and more complex changeover/changeback procedures;
- the performance of the analogue lines used to carry the signalling link will have a major impact on the throughput of signalling information that can be achieved;
- message delay may degrade the quality of service.

6.2.2 T1 link (ANSI Specification T1.111.2)

T1.111.2 figure 2

These figures should be treated as for information only. For the standard application, interface point C is appropriate.

T1.111.2 clause 4.4 - Analogue Signalling Link

The use of analogue circuits to support the signalling link is a service provider option.

T1.111.2 clause 5 - General

A signalling rate of 56/64 kbits/s is assumed. Lower bit rates (e.g. using analogue bearers) are a service provider option.

T1.111.2 clause 6 - Error Characteristics and Availability

Error characteristics and availability are an operator concern. Care should be taken as excessive errors could lead to inefficient use of the signalling link.

T1.111.2 clause 8 - Digital Signalling Data Link

The standard arrangement will be to derive a signalling link from a 1 544 kbits/s digital path.

T1.111.2 clause 9 - Analogue Signalling Data Link

Only digital signalling data links are required.

The use of Analogue bearers to support this interface is considered a service provider option. However, it should be noted that there will be potential problems with the following areas:

- the signalling load may exceed that which can be carried by a single low rate Analogue link, which may lead to an excessive number of signalling links and more complex changeover/change back procedures;
- the performance of the Analogue lines used to carry the signalling link will have a major impact on the throughput of signalling information that can be achieved;
- message delay may degrade the quality of service.

6.3 Level 2

6.3.1 E1 link (ITU-T Recommendation Q.703)

Q.703 clause 4.4

Only the basic error correction protocol is required.

Q.703 clause 4.7

Only the emergency proving period and status indications should be used by the BSS.

Q.703 clause 9

Not applicable, only basic error correction is required.

Q.703 clause 40

In the initial alignment procedure specified in ITU-T Recommendation Q.703, only the emergency proving is applicable for the BSS. Thus, in states 02 and 03 of the initial alignment procedure status indication "N" is not sent from the BSS. The BSS should be capable of recognising status indication "N" if received in order for the alignment procedure to complete.

Q.703 clause 8

The processor outage status indicator shall be recognised at the BSS and the procedures defined in ITU-T Recommendation Q.703 clause 8 supported.

The BSS shall support the generation of the processor outage indication towards the MSC if this is appropriate.

Q.703 clause 40

Only the emergency alignment procedures are required.

6.3.2 T1 link (ANSI Specification T1.111.3)

T1.111.3 clause 4.4 - Signal Unit Error Correction

Only the basic error correction protocol is required.

T1.111.3 clause 4.7

Only the emergency proving period and status indications should be used by the BSS.

T1.111.3 clause 9 - Preventive Cyclic Retransmission Error Correction Method

Only basic error correction is required for the A-Interface.

T1.111.3 clause 40 - Signalling Link Initial Alignment Procedure

In the initial alignment procedure, only the emergency proving is required for the BSS. Thus, in states 02 and 03 of the initial alignment procedure status indication "N" is not sent from the BSS. The BSS should be capable of recognizing status indication "N" if received in order for the alignment procedure to complete.

T1.113 clause 8

The processor outage status indicator shall be recognised at the BSS and the procedures defined in ANSI standards T1.113 clause 8 supported.

The BSS shall support the generation of the processor outage indication towards the MSC if this is appropriate.

T1.113 clause 40

Only the emergency alignment procedures are required.

6.4 Level 3

6.4.1 E1 link (ITU-T Recommendation Q.704)

Q.704 clause 4.1.2.

It should be noted that for point to point working, there will be no signalling transfer point network management features which need to be considered.

Q.704 clause 4.3

Signalling link management is required. Load sharing is required, and changeover/back between links within a single linkset are required.

Q.704 clause 5

Since STP working at the BSS is not required the discrimination and routing functions of the MTP used for GSM application can be significantly simplified.

Q.704 clause 5.2 - Routing label

Load sharing will be performed on BSS s with more than one signalling link by means of the signalling link selection field (SLS).

Q.704 clause 5.3 - Message routing function

It should be noted that for point to point working, load sharing between linksets is not required since there will only be one linkset between BSS and MSC.

Q.704 clause 5.3.5

Either of the two methods of congestion control is acceptable. The most appropriate method is dependent on national ITU-T No. 7 implementations.

Q.704 clause 5.4 - Message discrimination

At the BSS only messages with a correctly checking DPC will be accepted. Others will be discarded. It is recommended that discarding a message because of an incorrectly set point code causes an incident report to be generated.

At an MSC (which has the capability of acting as an STP) the messages not destined to it may be directed to the routing function.

The signalling point code for an BSS may be included in the national signalling point code scheme or in a separate signalling network. In the case where the signalling point code is in the national network the MSC need have only one point code, in the case where the signalling point code is in a separate "PLMN" signalling network, the MSC will be required to have two signalling point codes, one for each network.

Q.704 clause 6.1.3 c)

It should be noted that for point to point working, there is no requirement for signalling route management.

Q.704 clause 6.3.1.3

It should be noted that for point to point working, there is no requirement for signalling route management.

Q.704 clause 6.3.2.3

It should be noted that for point to point working, there is no requirement for signalling route management.

Q.704 clause 6.3.3.3

It should be noted that for point to point working, there is no requirement for signalling route management.

Q.704 clause 6.3.4.3

It should be noted that for point to point working, there is no requirement for signalling route management.

Q.704 clause 6.3.5.2

It should be noted that for point to point working, there is no requirement for signalling route management or signalling link blocking initiated by a management system.

Q.704 clause 6.3.6.2

It should be noted that for point to point working, there is no requirement for signalling route management or signalling link blocking initiated by a management system.

Q.704 clause 6.4.1

It should be noted that for point to point working, the signalling route will become unavailable when the associated link set fails.

Q.704 clause 6.4.2

It should be noted that for point to point working, the signalling route will become available when the associated link set is restored.

Q.704 clause 6.4.3

Not applicable.

Q.704 clause 6.5.1

It should be noted that for point to point working the procedures used in connection with signalling route unavailability will be those specified for signalling route set unavailability in ITU-T Recommendation Q.704 clause 40.2.1.

Q.704 clause 6.5.2

It should be noted that for point to point interworking the procedures used in connection with signalling route availability will be those specified for signalling route set availability in ITU-T Recommendation Q.704 clause 40.2.2.

Q.704 clause 6.5.3

Not applicable.

Q.704 clause 6.8.2

There are two acceptable methods of congestion control defined in ITU-T Recommendation Q.704, in clauses 3.6.2.1 a) and b). The most appropriate method is dependent on national ITU-T No. 7 implementations. Each administration should specify its congestion threshold setting algorithm and nodal congestion abatement procedures at system procurement.

Q.704 clause 6.8.5.2

It should be noted that for point to point working, the signalling-route-set-congestion-test procedure is not required.

Q.704 clause 7.1.2

It should be noted that for point to point working, signalling routes are not applicable.

Q.704 clause 7.2

The normal routing situation will be that there are 1 or more signalling links available between a BSS and MSC, these will constitute a link set. They will be run in a load sharing mode and changeover, changeback procedures will be supported between these signalling links.

Furthermore, in case of more than one link set (not for point to point working), load sharing between link sets is also allowed.

Q.704 clause 7.3.3

It should be noted that for point to point working, there will be no alternative linkset.

Q.704 clause 7.4.3

Not applicable in case of point to point working.

Q.704 clause 7.5

Not applicable in case of point to point working.

Q.704 clause 7.6

Not applicable in case of point to point working.

Q.704 clause 7.7

Not applicable.

Q.704 clause 8 - Changeover

It should be noted that for point to point working, changeover between link sets is not applicable.

Q.704 clause 9 - Changeback

It should be noted that for point to point working, changeover between link sets is not applicable.

Q.704 clause 40

It should be noted that for point to point working, forced re-routing is not applicable since there is only one signalling route existing between BSS and MSC.

Q.704 clause 8

Not applicable in case of point to point working since there is only one signalling route existing between BSS and MSC.

Q.704 clause 41

It should be noted that for point to point working the signalling route set will consist of one associated signalling route only.

Q.704 clause 42 - Signalling link management

Only basic link management procedures are applicable.

Q.704 clause 42.3.4 - Link set activation

Link set normal activation defined in clause 41.2.4.1 is not applicable. Link set emergency restart at the BSS is used in all cases.

Q.704 clause 43.2 - Transfer prohibited

It should be noted that for point to point working, the transfer prohibited function is not applicable.

Q.704 clause 43.3 - Transfer allowed

It should be noted that for point to point working, the transfer allowed function is not applicable.

Q.704 clause 43.4 - Transfer restricted

It should be noted that for point to point working, the transfer restricted function is not applicable.

Q.704 clause 43.5 - Signalling-route-set-test

It should be noted that for point to point working, the signalling -route-set-test procedure is not applicable.

Q.704 clauses 13.6, 13.7 and 13.8 - Transfer controlled

It should be noted that for point to point working, the transfer controlled function is not applicable. **Q.704 clause 43.9 - Signalling route-set-congestion-test**

It should be noted that for point to point working, the signalling route-set-congestion-test function is not applicable.

Q.704 clause 44.2.1

Since all messages are passed using the SCCP, the service indicator will be:

bits	D	C	B	A
	0	0	1	1

Q.704 clause 44.2.2

The sub service field will always be set to one of the following values:

bits	
D C	
1 0	national network
1 1	local network

Q.704 clause 44.3

This information for SCCP is defined in ITU-T Recommendation Q.713.

Q.704 clause 45

The formats and codes listed are only relevant to the messages that are required, i.e. those not excluded in the rest of this recommendation.

6.4.2 T1 link (ANSI Specification T1.111.4)

T1.111.4 clause 4.1.2

Signalling Transfer Point network management procedures are not required in case of point to point working.

T1.111.4 clause 4.3

Signalling link management is required. Load sharing is required, and changeover/back between links within a single linkset are required.

T1.111.4 clause 5 - Signalling Message Handling

Since STP functionality is not required at the BSS the discrimination and routing functions of the MTP can be significantly simplified.

T1.111.4 clause 5.2 - Routing Label

Load sharing will be performed on BSSs with more than one signalling link by means of the Signalling Link Selection (SLS) field.

T1.111.4 clause 5.3 - Message Routing Function

It should be noted that for point to point working, load sharing between linksets is not required since only one linkset between the BSS and the MSC is required for the A-Interface.

T1.111.4 clause 5.4 - Message Discrimination

It is recommended that discarding a message at the BSS because of an incorrectly set point code should cause an incident report to be generated.

At an MSC (which has the capability of acting as an STP) the messages not destined to it may be directed to the routing function.

The signalling point code for an BSS may be included in the national signalling point code scheme or in a separate signalling network. In the case where the signalling point code is in the national network the MSC need have only one point code, in the case where signalling point code is in a separate PLMN signalling network, the MSC will be required to have two signalling point codes, one for each network.

The User Part Unavailable message is not required for the A-Interface.

T1.111.4 clause 5.3.5

Support of ANSI specific Signalling Link Congestion Control as specified in this clause is required.

T1.111.4 clause 6 - Signalling Network Management

It should be noted that for point to point working, Signalling Route Management, including the status of signalling routes, signalling route restricted, signalling route unavailability and availability, is not required.

T1.111.4 clause 6.1.3 c)

It should be noted that for point to point working, there is no requirement for signalling route management.

T1.111.4 clause 6.3.1.3

It should be noted that for point to point working, there is no requirement for signalling route management.

T1.111.4 clause 6.3.2.3

It should be noted that for point to point working, there is no requirement for signalling route management.

T1.111.4 clause 6.3.3.3

It should be noted that for point to point working, there is no requirement for signalling route management.

T1.111.4 clause 6.3.4.3

It should be noted that for point to point working, there is no requirement for signalling route management.

T1.111.4 clause 6.3.5.2

It should be noted that for point to point working, there is no requirement for signalling route management or signalling link blocking initiated by a management system.

T1.111.4 clause 6.3.6.2

It should be noted that for point to point working, there is no requirement for signalling route management or signalling link unblocking initiated by a management system.

T1.111.4 clause 6.4.1

It should be noted that for point to point working, the signalling route will become unavailable when the associated link set fails.

T1.111.4 clause 6.4.2

It should be noted that for point to point working, the signalling route will become available when the associated link set is restored.

T1.111.4 clause 6.4.3

Not applicable.

T1.111.4 clause 6.5.1

It should be noted that for point to point working the procedures used in connection with signalling route unavailability will be those specified for signalling route set unavailability in T1.111.4 clause 40.2.1.

T1.111.4 clause 6.5.2

It should be noted that for point to point interworking the procedures used in connection with signalling route availability will be those specified for signalling route set availability in ANSI standard T1.111.4 clause 40.2.2.

T1.111.4 clause 6.5.3

Not applicable.

T1.111.4 clause 6.8.2

Support of ANSI specific Signalling Link Congestion Control as specified in this clause is required.

T1.111.4 clause 6.8.5.2

It should be noted that for point to point working, the signalling-route-set-congestion-test procedure is not required.

T1.111.4 clause 7 - Signalling Traffic Management

It should be noted that for point to point working, the Traffic Management procedures supporting signalling routes, including signalling route restricted, signalling route unavailability and availability, are not required.

T1.111.4 clause 7.1.2

It should be noted that for point to point working, signalling routes are not applicable.

T1.111.4 clause 7.2

The normal routing situation will be that there are one or more signalling links available between the BSS and the MSC, which will constitute a link set. They will be run in a load sharing mode and changeover, change back procedures will be supported between these signalling links.

Furthermore, in case of more than one link set (not for point to point working), load sharing between link sets is also allowed.

T1.111.4 clause 7.3.3

It should be noted that for point to point working, alternative linksets are not required.

T1.111.4 clause 7.4.3

Not Applicable in case of point to point working.

T1.111.4 clause 7.5

Not Applicable in case of point to point working.

T1.111.4 clause 7.6

Not Applicable in case of point to point working.

T1.111.4 clause 7.7

Not Applicable.

T1.111.4 clause 8 - Changeover

It should be noted that for point to point working, the changeover procedure between linksets is not applicable.

T1.111.4 clause 9 - Changeback

It should be noted that for point to point working, the changeback procedure between linksets is not applicable.

T1.111.4 clause 40 - Forced Rerouting

It should be noted that for point to point working, forced rerouting is not applicable.

T1.111.4 clause 8 - Controlled Rerouting

It should be noted that for point to point working, controlled rerouting is not applicable.

T1.111.4 clause 9 - MTP Restart

The MTP Restart procedure is not required for the A-Interface.

T1.111.4 clause 41 - Signalling Traffic Flow Control

It should be noted that for point to point working, the signalling route procedures supporting signalling traffic flow control including signalling-route-unavailability, signalling-route availability and signalling-route-set-congestion are not applicable.

T1.111.4 clause 42 - Signalling Link Management

Only basic link management procedures are required for the A-Interface.

T1.111.4 clause 42.3.4 - Link set activation

Link set normal activation is not applicable. Link set emergency restart at the BSS is used in all cases.

T1.111.4 clause 43 - Signalling Route Management

It should be noted that for point to point working, signalling route management is not applicable. No action is required upon reception of a TFP, TFR, TFA, signalling-route-set-test, signalling-route-set-congestion-test or transfer controlled message in case of point to point working.

T1.111.4 clause 43.3 - Transfer allowed

It should be noted that for point to point working, the transfer allowed function is not applicable. **T1.111.4 clause 43.4 - Transfer restricted**

It should be noted that for point to point working, the transfer restricted function is not applicable.

T1.111.4 clause 43.5 - Signalling-route-set-test

It should be noted that for point to point working, the signalling-route-set-test procedure is not applicable.

T1.111.4 clauses 13.6, 13.7 and 13.8 - Transfer controlled

It should be noted that for point to point working, the transfer controlled function is not applicable.

T1.111.4 clause 43.9 - Signalling route-set-congestion-test

It should be noted that for point to point working, the signalling route-set-congestion-test function is not applicable.

T1.111.4 clause 44.2.1 - Service Indicator

The values for the service indicator shall conform to clause 44.2.1.

T1.111.4 clause 44.2.2

The sub-service field will always be set to one of the following values:

bits
 DC
 1 0 national network
 1 1 local network

NOTE: Local network value is not used for PCS 1900 in North America.

T1.111.4 clause 44.3

This information for SCCP is defined in ANSIT1.112.3.

T1.111.4 clause 45

The formats and codes listed are only relevant to the messages that are required for the A-Interface, i.e. those not excluded in the rest of this recommendation.

6.5 Testing and Maintenance

6.5.1 E1 link (ITU-T Recommendation Q.707)

Q.707 clause 5.2

The MSC and the BSS shall be capable of responding with an acknowledgement message to a SLTM received at any time as specified in ITU-T Recommendation Q.707 clause 5.2.

6.5.2 T1 link (ANSI Specification T1.111.7)

T1.111.7 clause 5.1 - Signalling Data Link Test

The signalling data link test is not required for the A-Interface.

T1.111.7 clause 5.2

The generation of a SLTM is not required; however, the MSC and the BSS shall be capable of responding with an acknowledgement message to a SLTM that is received at any time as specified in T1.111.7, clause 5.2.

6a Message Transfer Part 3 (MTP3) – User Adaptation Layer (M3UA) functions

6a.1 Introduction

This subclause specifies the transport protocol stack that supports the transfer of BSSAP messages over an IP transport.

The following requirements can be stated:

- provide reliable transfer of control plane signalling messages in both connectionless mode and connection-oriented mode;
- provide separate independent connections for distinguishing transactions with individual MS's;
- supervise the 'MS connections' and provide connection status information to the Upper Layers for individual MS's;
- provide networking and routing functions;
- provide redundancy in the signalling network;
- provide load sharing.

6a.2 Protocol Stack

Figure 1a below shows the point at which the service primitives are invoked. A single SAP is defined independently of the signalling bearer. The SAP provides the SCCP primitives. The figure is not intended to constrain the architecture.

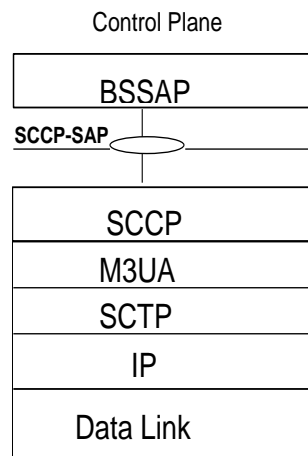

Figure 6a.2.a: SAP between BSSAP and its transport over IP

1. **SCCP** [62] provides connectionless service, class 0, connection oriented service, class 2, separation of the connections mobile by mobile basis on the connection oriented link and establishment of a connection oriented link mobile by mobile basis.
2. **M3UA** refers to the SCCP adaptation layer "SS7 MTP3 – User Adaptation Layer" [73] also developed by the Sigtran working group of the IETF.
3. **SCTP** refers to the Stream Control Transmission Protocol [72] developed by the Sigtran working group of the IETF for the purpose of transporting various signalling protocols over IP networks. The checksum method specified in RFC 3309 [81] shall be used instead of the method specified in RFC 2960 [72].
4. **IP**. IPv6 should be supported according to [83]. IPv4 support [82] is optional.

NOTE: This does not preclude the single implementation and use of IPv4. Due to the possible transition from IPv4 to IPv6 the IP dual stack support is recommended.

A BSC/MSC using IP transport shall support Diffserv code point marking [80]. The Diffserv code point may be determined from the application parameters.

6a.3 Data Link Layer

It is recommended that a BSC/MSC using IP transport implement the data link layer using Ethernet.

NOTE: This does not preclude the single implementation and use of any other data link layer protocol fulfilling the GERAN requirements toward the upper layers.

A BSC/MSC using IP transport having interfaces connected via low bandwidth PPP links like E1/T1 shall also support IP Header Compression [76] and the PPP extensions ML/MC-PPP [77], [78]. In this case, the negotiation of header compression [76] over PPP shall be performed according to [79].

7 Interface functions

The method of interfacing to the higher layers will be by the primitives defined in ITU-T Recommendation Q.701 clause 8 of the Blue Book for E1 links and T1.111 for T1 links.

The primitives defined are:

- MTP Pause indication;
- MTP Resume indication;
- MTP Status indication;
- MTP Transfer request;
- MTP Transfer indication.

8 SCCP functions

8.1 Overview

The purpose of this clause is to identify the subset of the SCCP functions which are necessary to achieve the management of the MS references in the BSS to MSC interface, and to provide addressing facilities. If this subset of SCCP functions is implemented, compatibility with a full ITU-T SCCP (ANSI SCCP if T1 links are used) must be maintained for E1 links (T1 links). Only the needs of the BSSAP are taken into account in clause 8: the operations and maintenance requirements about SCCP functions are discussed in clause 40.

These simplifications are applicable to the signalling between BSS and MSC in GSM PLMNs.

In order to limit the complexity of the procedures, a BSS exchanges signalling messages only with its MSC, where a protocol conversion may be needed in some cases. Therefore no SCCP translation function is required in the MSC between the national and the local MTP. The Destination Point Code and Subsystem Number allow direct routing by the local SCCP and MTP within the MSC area. Therefore, no SCCP Global Title Translation (GTT) function is required.

Several functions of the SCCP are not used on the MSC/BSS interface: error detection, receipt confirmation, flow control.

The segmenting/reassembling function shall be used if the total message length exceeds the maximum allowed message length that can be carried by the MTP.

For E1 links, the minimum set of SCCP functions which apply are specified in the Blue Book ITU-T Recommendations Q.711, Q.712, Q.713 and Q.714, with the qualifications specified in this Recommendation.

For T1 links, the minimum set of SCCP functions which apply are specified in ANSI T1.112 with the qualifications specified in this Recommendation.

8.2 Primitives

8.2.1 E1 link (ITU-T Recommendation Q.711)

Q.711 table 1

Three primitives of the table 1/Q.711 are not used:

- N-EXPEDITED DATA;
- N-DATA ACKNOWLEDGE;
- N-RESET.

Q.711 table 2

The following parameters of the N-CONNECT primitive are not used:

- responding address;
- receipt confirmation selection;
- expedited data selection.

Q.711 table 3

The following parameter of the N-DATA primitive is not used:

- confirmation request.

Q.711 table 6

The following parameter of the N-DISCONNECT primitive is not used:

- responding address.

Q.711 clause 5.1.2

Permanent signalling connections: not applicable.

Q.711 table 9

The primitive N-NOTICE is not used.

Q.711 table 10

The following parameter of the N-UNITDATA is not used:

- return option.

Q.711 clause 7.1.2

Functions for permanent signalling connections: not applicable.

8.2.2 T1 link (ANSI Specification T1.112.1)

T1.111.1 table 1

Two primitives of the table are not used:

- N-INFORM DATA;
- N-RESET.

T1.112.1 table 2

The following parameters of the N-CONNECT primitive are not used:

- responding address;
- receipt confirmation selection;
- expedited data selection.

T1.112.1 table 3

The following parameter of the N-DATA primitive is not used:

- confirmation request.

T1.112.1 table 6

The following parameter of the N-DISCONNECT primitive is not used:

- responding address.

T1.112.1 clause 2.1.2

Permanent signalling connections are not applicable.

T1.112.1 table 8

The primitive N-NOTICE is not used.

T1.112.1 table 8A

The following parameter of the N-UNITDATA is not used:

- return option.

T1.112.1 clause 4.1.2

Functions for permanent signalling connections are not applicable.

8.3 SCCP messages

8.3.1 E1 link (ITU-T Recommendation Q.712)

Q.712 clause 4.4

The Data Acknowledgement (AK) message is not used.

Q.712 clause 4.6

The Data Form 2 (DT2) message is not used.

Q.712 clause 4.7

The Expedited Data (ED) message is not used.

Q.712 clause 4.8

The Expedited Data Acknowledgement (EA) message is not used.

Q.712 clause 4.10

The Protocol Data Unit Error (ERR) message is not used: the inconsistent messages of the SCCP protocol are discarded.

Q.712 clause 4.13

The Reset Confirm (RSC) message is not used.

Q.712 clause 4.14

The Reset Request (RSR) message is not used.

Q.712 clause 4.16

The Subsystem-Out-Of-Service-Grant (SOG) message is not used.

Q.712 clause 4.17

The Subsystem-Out-Of-Service-Request (SOR) message is not used.

Q.712 clause 4.21

The Unitdata Service (UDTS) message is not used.

Q.712 clause 5.4

The "credit" parameter field is not used for protocol class 2. However the parameter must still be included in the IT message for syntax reasons.

Q.712 clause 5.7

The "error cause" parameter field is not used.

Q.712 clause 5.11

The "receive sequence number" parameter is not used.

Q.712 clause 5.14

The "reset cause" parameter field should not be used.

Q.712 clause 5.16

The "sequencing/segmenting" parameter field is not used for protocol class 2. However the parameter must still be included in the IT message for syntax reasons.

8.3.2 T1 link (ANSI Specification T1.112.2)

T1.112.2 clause 5.4

The Data Acknowledgement (AK) message is not used.

T1.112.2 clause 5.6

The Data Form 2 (DT2) message is not used.

T1.112.2 clause 5.7

The Expedited Data (ED) message is not used.

T1.112.2 clause 5.8

The Expedited Data Acknowledgement (EA) message is not used.

T1.112.2 clause 5.10

The Protocol Data Unit Error (ERR) message is not used. Inconsistent messages of the SCCP protocol are discarded.

T1.112.2 clause 5.13

The Reset Confirm (RSC) message is not used.

T1.112.2 clause 5.14

The Reset Request (RSR) message is not used.

T1.112.2 clause 5.16

The Unitdata Service (UDTS) message is not used.

T1.112.2 clause 6.4

The Subsystem-Out-Of-Service-Request (SOR) message is not used.

T1.112.2 clause 6.5

The Subsystem-Out-Of-Service-Grant (SOG) message is not used.

T1.112.2 clause 7.2

The "credit" parameter field is not used for protocol class 2. However, the parameter must still be included in the Inactivity Test (IT) message for syntax reasons.

T1.112.2 clause 7.6

The "error cause" parameter field is not used.

T1.112.2 clause 7.10

The "receive sequence number" parameter is not used.

T1.112.2 clause 7.13

The "reset cause" parameter field should not be used.

T1.112.2 clause 7.16

The "sequencing/segmenting" parameter field is not used for protocol class 2. However, the parameter must still be included in the IT message for syntax reasons.

8.4 SCCP formats and codes

8.4.1 E1 link (ITU-T Recommendation Q.713)

Q.713 clause 6.4

For point-to-point network structures (i.e. direct connections between MSC and BSS) the called party address may consist of the single element:

- sub-system number.

No global title is used. The signalling point code which is coded in the MTP routing label and the subsystem number in the called party address allow the routing of the message.

Then the following encoding of the address indicator may be chosen: **X1000010**.

If a non point-to-point network structure is used then the global title may be required. This is a national concern.

Q.713 clause 6.4.2.2

The SSN values used on the MSC - BSS interface are specified in 3GPP TS 23.003.

Use of alternative values is a national concern.

Q.713 clause 6.4.2.3

Global title: refer to ITU-T Recommendation Q.713 clause 6.4.

Q.713 clause 6.6

Protocol class: the classes 1 and 3 are not used.

Q.713 clauses 3.8, 3.9, 3.10, 3.13 and 3.14

Parameters not used.

Q.713 clauses 4.8, 4.9, 4.11, 4.12, 4.13, 4.14, 4.15 and 4.16

Messages not used.

Q.713 clause 8.1.1

SOR and SOG not needed.

8.4.2 T1 link (ANSI Specification T1.112.3)

T1.112.3 clause 3.4

For point-to-point network structures (*i.e.*, direct connections between the MSC and the BSS) the called party address may consist of the single element:

- subsystem number.

No global title is used. The signalling point code which is coded in the MTP routing label and the subsystem number in the called party address allow the routing of the message. Then the following encoding of the address indicator may be chosen: **x1000001**.

Separate SSNs are needed to distinguish BSSAP and MAP; the chosen SSNs are network specific and may need to differ from those assigned to other applications (e.g. TCAP applications).

T1.112.3 clause 6.4.2.2

Allocation of the subsystem number is an operator concern.

T1.112.3 clause 6.4.2.3

T1.112.3 clause 6.4

T1.112.3 clause 6.6

Protocol class: the classes 1 and 3 are not used.

T1.112.3 clauses 3.8, 3.9, 3.10, 3.13 and 3.14

Parameters are not used.

T1.112.3 clauses 4.8, 4.9, 4.11, 4.12, 4.13, 4.14, 4.15 and 4.16

Messages are not used.

T1.112.3 clause 8.1.1

Subsystem-out-of-service-request (SOR) and Subsystem-out-of-service-grant (SOG) are not needed.

8.5 SCCP procedures

8.5.1 E1 link (ITU-T Recommendation Q.714)

Q.714 clauses 1.1.2.2 and 1.1.2.4

Protocol classes 1 and 3 not used.

Q.714 clause 4.1.3

A signalling connection consists of a single connection clause. No intermediate nodes are defined in the MSC/BSS protocol.

The use of multiple connection clauses is a national concern.

Q.714 clause 4.2.1 (b)

Not applicable for single connections.

Q.714 clause 5.1 (1.)

Global title not used for single connections.

Q.714 clause 5.2.1

Subsystem (SSN) only is present in the called party address for single connections.

Q.714 clause 5.2.2

The addressing information may take the following form in the N-CONNECT request primitive: DPC+SSN (for single connections).

Q.714 clause 5.2.2.2

No SCCP translation function is required for single connections.

Q.714 clause 5.3.1 (3)

Not applicable for single connections.

Q.714 clause 5.3.2 (4)

Not applicable for single connections.

Q.714 clause 6.1.3

Not applicable: no protocol class and flow control negotiations.

Q.714 clause 6.1.5

Not applicable.

Q.714 clause 6.2.2

Not applicable.

Q.714 clause 6.3.4

Not applicable.

Q.714 clause 6.5.1.2

Not applicable.

Q.714 clause 6.5.2

Not applicable.

Q.714 clauses 3.6, 3.7, 3.9 and 3.10

Not applicable.

Q.714 clause 7.2

Message return not applicable.

Q.714 clause 8

Only those messages and procedures relating to non-replicated subsystems or nodes are required. At the BSS the concerned point will be the parent MSC. The subsystems involved are the BSSAP and the OMAP.

8.5.2 T1 link (ANSI Specification T1.112.4)

T1.112.4 clauses 1.1.2.2 and 1.1.2.4

Protocol classes 1 and 3 are not used.

T1.112.4 clause 4.1.3

A signalling connection consists of a single connection clause. No intermediate nodes are defined in the MSC to BSS interface.

The use of multiple connection clauses is a operator option.

T1.112.4 clause 4.2.1 (b)

Not applicable for single connections.

T1.112.4 clause 5.1 (1.)

Global title is not used for single connections.

T1.112.4 clause 5.2.1

Subsystem number (SSN) only is present in the called party address for single connections.

T1.112.4 clause 5.2.2

The addressing information may take the following form in the N-CONNECT request primitive: DPC+SSN (for single connections).

T1.112.4 clause 5.2.2.2

No SCCP translation function is required for single connections.

T1.112.4 clause 5.3.1 (3)

Not applicable for single connections.

T1.112.4 clause 5.3.2 (4)

Not applicable for single connections.

T1.112.4 clause 6.1.3

Not applicable. No protocol class and flow control negotiations.

T1.112.4 clause 6.1.5

Not applicable.

T1.112.4 clause 6.2.2

Not applicable.

T1.112.4 clause 6.3.4

Not applicable.

T1.112.4 clause 6.5.1.2

Not applicable.

T1.112.4 clause 6.5.2

Not applicable.

T1.112.4 clauses 3.6, 3.7, 3.9 and 3.10

Not applicable.

T1.112.4 clause 7.2

Message return is not applicable.

T1.112.4 clause 8

Only those messages and procedures relating to non-replicated subsystems or nodes are required. At the BSS the concerned point will be the parent MSC. The subsystems involved are the BSSAP and the MAP.

9 Use of the SCCP

The MTP and the SCCP are used to support signalling messages between the MSC and the BSS. One user function of the SCCP, called BSS Application Part (BSSAP) is defined. In the case of point-to-point calls the BSSAP uses one signalling connection per active Mobile Station having one or more active transactions for the transfer of layer 3 messages. In the case of a voice group or broadcast call there is always one connection per cell involved in the call and one additional connection per BSS for the transmission of layer 3 messages. There is an additional connection for the speaker in a broadcast call or the first speaker in a voice group call up to the point at which the network decides to transfer them to a common channel. Additional connections may also be required for any mobile stations in the voice group or broadcast call which the network decides to place on a dedicated connection. The BSSAP user function is further subdivided into two separate functions:

- the Direct Transfer Application sub-Part (DTAP) is used to transfer messages between the MSC and the MS; the layer-3 information in these messages is not interpreted by the BSS. The descriptions of the layer 3 protocols for the MS-MSC information exchange are contained in the 04-series of 3GPP TS Technical Specifications;
- the BSS Management Application sub-Part (BSSMAP) supports other procedures between the MSC and the BSS related to the MS (resource management, handover control), or to a cell within the BSS, or to the whole BSS. The description of the layer 3 protocol for the BSSMAP information exchange is contained in 3GPP TS 48.008.

Both connectionless and connection-oriented procedures are used to support the BSSMAP. 3GPP TS 48.008 explains whether connection oriented or connectionless services should be used for each layer 3 procedure. Connection oriented procedures are used to support the DTAP. Clause 9.4 deals with the use of connectionless services of the SCCP.

A distribution function located in BSSAP, which is reflected in the protocol specification by the layer 3 header defined in clause 9.3, performs the discrimination between the data related to those two subparts, as illustrated in 3GPP TS 48.008, figure 1.

The error handling for the BSSAP header is specified in 3GPP TS 48.008.

This clause describes the use of SCCP connections for MS transactions. Clause 9.1 describes the connection establishment procedures. Clause 9.2 describes the connection release procedures. Clause 9.3 describes the distribution between BSSMAP and DTAP messages and the data transfer over a SCCP connection. The structure of the user data field in the SCCP message is described in clauses 9.3 and 9.4 and in figure 3.

9.1 Connection establishment

A new SCCP connection is established when information related to the communication between an MS and the network on a dedicated radio resource has to be exchanged between BSS and MSC, and no such SCCP connection exists between the MSC and the BSS involved for the concerned mobile station. A new SCCP connection for each cell, an additional connection for each BSS, and optionally connections for particular participants in a voice group or broadcast call are established when a voice group or broadcast call is established. A new SCCP connection is also established in the case of an external handover between the cells of one BSS for a point-to-point call, or for participants in a voice group or broadcast call who are supported on a dedicated channel.

Various SCCP connection establishment cases have to be distinguished:

- i) following an Access Request made by the MS on the Random Access Channel, a dedicated radio resource has been successfully allocated and a layer-2 connection has been established on the allocated resource. The SCCP connection establishment is then initiated by the BSS;
- ii) the MSC decides to perform an external handover and a new dedicated radio resource has to be reserved in the new BSS. The SCCP connection establishment is then initiated by the MSC;

NOTE: The old BSS and the new BSS may be the same.

- iii) following a request for a voice group or broadcast call received at a MSC, SCCP connections are established between the MSC and BSS. This is initiated by the MSC. Note that a SCCP connection for the originator has already been established via case i);
- iv) during a voice group or broadcast call the network may decide to place some participants on a dedicated channel and will perform SCCP connection establishment to support this channel.

The above cases are the only cases currently identified for SCCP connection establishment. Others may emerge in the future.

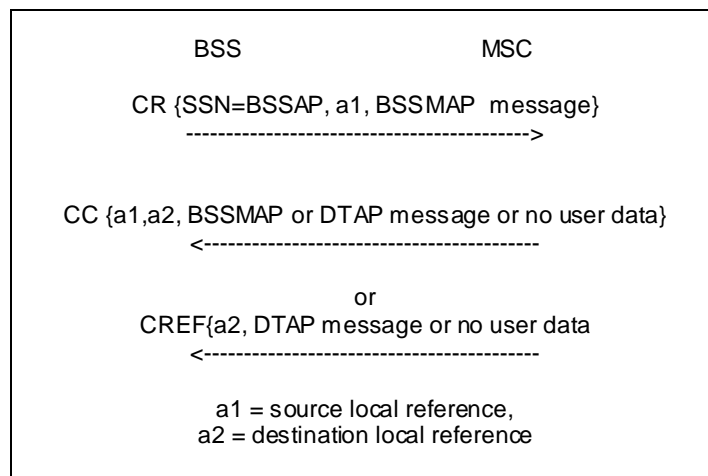

CC: Connection Confirm.
 CR: Connection Request.
 CREF: Connection Refused.

Figure 1: Set-up of SCCP connections on the first BSS/MSC interface

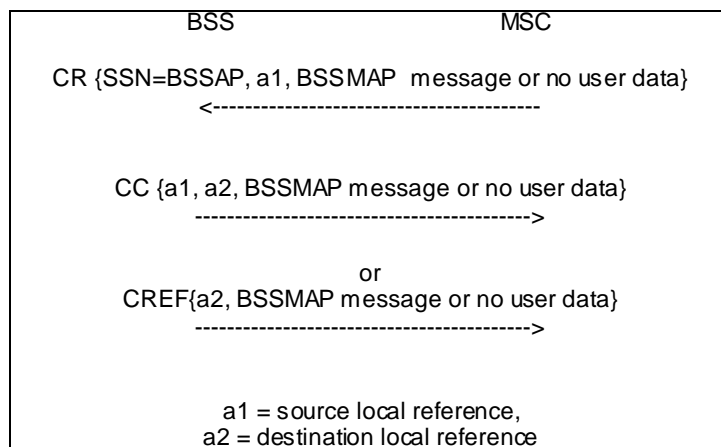

CC: Connection Confirm.
 CR: Connection Request.
 CREF: Connection Refused.

Figure 2: Set-up of SCCP connections on a new BSS/MSC (handover) interface or for a voice group or broadcast call initiation

9.1.1 Establishment procedure in case i)

In this case, the connection establishment is performed at the reception by the BSS of the first layer-3 message from the MS (piggybacked on the SABM frame). This message (LOCATION UPDATING REQUEST, CM-SERVICE REQUEST, CM REESTABLISHMENT REQUEST, IMSI DETACH, PAGING RESPONSE, or IMMEDIATE SETUP) which contains the identity of the MS is transferred to the MSC together with a cell identification, in a BSSMAP message (COMPLETE L3 INFORMATION) included in the user data field of the SCCP Connection Request message (see figure 1).

After the reception of the Connection Request message, the MSC may check, based on the received identity, whether another association already exists for the same Mobile Subscriber. Two options among others are described hereafter:

- after the reception of the Connection Request message, the MSC sends a Connection Confirm message and checks based on the received identity, whether another connection already exists for the same Mobile Subscriber. If another connection exists for the same Mobile Subscriber, the resources assigned for this previous connection are released after the identity of the Mobile Subscriber using the new connection has been successfully checked, e.g. by authentication or by ciphering procedure;
- if such an association exists, the connection establishment is refused by sending a Connection Refused message;

NOTE: The first option allows the new establishments and the reestablishments.

- when the SCCP connection is to be established, a Connection Confirm message is sent back to the BSS. This message may optionally contain a BSSMAP or DTAP message in the user data field.

If the connection establishment is refused for any reason, a SCCP Connection Refused message is sent back to the BSS. This message may optionally contain, in the user data field, a DTAP message which is forwarded to the MS.

The procedures in case of connection establishment failure are specified in 3GPP TS 48.008.

9.1.2 Establishment procedure in case ii)

In this case, the connection establishment is undertaken by the MSC as soon as the MSC decides to perform an external handover to a new cell for a point-to-point call or for participants in a voice group or broadcast call who are supported on a dedicated channel.

A Connection Request message is sent to the BSS. The user data field of this message may contain the BSSMAP HANDOVER REQUEST message (see figure 2). It is preferable to transfer the layer 3 messages in the user data field of the Connection Request in order to complete the establishment of the relation between the radio channel requested and the SCCP connection as soon as possible. However, the MSC shall not piggyback the BSSMAP HANDOVER REQUEST message in the SCCP Connection Request message if that would result in the maximum length of the user data field being exceeded.

When receiving the Connection Request message, containing the BSSMAP HANDOVER REQUEST message, the BSS allocates the necessary resources for the requested handover. A Connection Confirm message is also returned to the MSC and may contain the BSSMAP HANDOVER REQUEST ACKNOWLEDGEMENT or QUEUEING INDICATION message in the user data field.

If the handover resource allocation fails (see 3GPP TS 48.008) before the SCCP connection is established then the SCCP Connection Refused message may contain the BSSMAP HANDOVER FAILURE message in the user data field.

The procedures in case of connection establishment failure are specified in 3GPP TS 48.008.

9.1.3 Establishment procedure in case iii)

In this case connection establishment is undertaken by the MSC on the reception of a voice group or broadcast call initiation request.

At the reception of the voice group or broadcast call establishment request message, the MSC will determine that a voice group or broadcast call is required and retrieve the required information concerning, inter alia, the affected cells. If A-interface link sharing does not apply, SCCP connections are then established by the MSC to the BSS for each of these cells. Otherwise, if A-interface link sharing applies, only one SCCP connection is established by the MSC to the BSS. Additionally, a separate SCCP connection is established by the MSC to each BSS in the call.

For each SCCP connection to be established, a Connection Request message is sent to the BSS. The user data field of this message may contain the VGCS/VBS SETUP or VGCS/VBS ASSIGNMENT REQUEST message (see figure 2). It is preferable to transfer the layer 3 messages in the user data field of the Connection Request in order to complete the establishment of the relation between the radio channel requested and the SCCP connection as soon as possible.

When receiving the Connection Request message, containing the VGCS/VBS SETUP or VGCS/VBS ASSIGNMENT REQUEST message, the BSS allocates the necessary resources for the requested call. A Connection Confirm message is also returned to the MSC and may contain the VGCS/VBS SETUP ACK, VGCS/VBS ASSIGNMENT RESULT or VGCS/VBS QUEUEING INDICATION message in the user data field.

If the resource allocation fails (see 3GPP TS 48.008) before the SCCP connection is established then the SCCP Connection Refused message may contain the VGCS/VBS SETUP REFUSE or VGCS/VBS ASSIGNMENT FAILURE message in the user data field.

The procedures in case of connection establishment failure are specified in 3GPP TS 48.008.

9.1.4 Establishment procedure in case iv)

In this case, the connection establishment may be performed at the request of the MSC.

The procedures in case of connection establishment failure are specified in 3GPP TS 48.008.

9.2 Connection release

This procedure is always initiated at the MSC side.

A connection is released when the MSC realizes that a given signalling connection is no longer required. That may occur, in normal cases:

- when a BSSAP release procedure is terminated;
- when a handover resource allocation procedure has failed and a signalling connection was established;
- when a VGCS/VBS set-up procedure has failed and a call controlling SCCP signalling connection was established;
- when a VGCS/VBS assignment procedure has failed and a resource controlling SCCP signalling connection was established.

The MSC sends a SCCP released message. This message shall not contain any user data field.

Abnormal cases: a connection failure may be detected by the connection supervision service provided by SCCP. The procedures in that case are specified in 3GPP TS 48.008.

9.3 Transfer of DTAP and BSSMAP data

The DTAP and BSSMAP Layer 3 messages between the MSC and the BSS are contained in the user data field of the exchanged SCCP frames. This field is optional for the Connection Request (CR) (except for BSS originated connections, see clause 9.1); Connection Confirm (CC) and Connection Refused (CREF). The use of this field in such frames in the various establishment cases, which allows reduction in delay and improves efficiency, is described in clause 9.1. The user data field is a mandatory parameter of the Data frames (DT); the user data field always contains either a DTAP or a BSSMAP message.

9.3.1 Distribution function

9.3.1.1 ITU-T Recommendation

The distribution of messages between the BSSMAP and DTAP functions and the distribution/multiplexing of DTAP messages to/from the various radio link layer 2 access points are performed in an intermediate layer of protocol between SCCP and Layer 3 later referred as the distribution sublayer.

The protocol for this sublayer simply consists of the management of a one or two octet Distribution Data Unit. Each SCCP User Data field necessarily contains such a distribution Data Unit as a header, followed by the length indicator and the actual Layer 3 BSSMAP or DTAP message.

9.3.1.2 ANSI Specification

The distribution of messages between the BSSMAP and DTAP functions and the distribution/multiplexing of DTAP messages to/from the various radio link layer 2 access points are performed by a function of BSSAP referred to as a distribution function. The distribution of messages is performed based on a distribution data unit.

The distribution data unit includes a Discrimination Parameter (DP) field, which is coded on one octet. One bit (i.e. least significant bit) of the octet referred to as a bit D indicates whether it is a DTAP (value D=1) or a BSSMAP (value D=0) message. The other bits of the octet can be used to separate message groups for different air interfaces (Figure below).

If a single radio system supports one air interface, the A-interface includes only one message group and no separation between message groups is needed. The case is different when radio system supports multiple air interfaces, and the A-interface includes several message groups. In that case, there must be a mechanism which facilitates the selection of the right message group according to the used air interface.

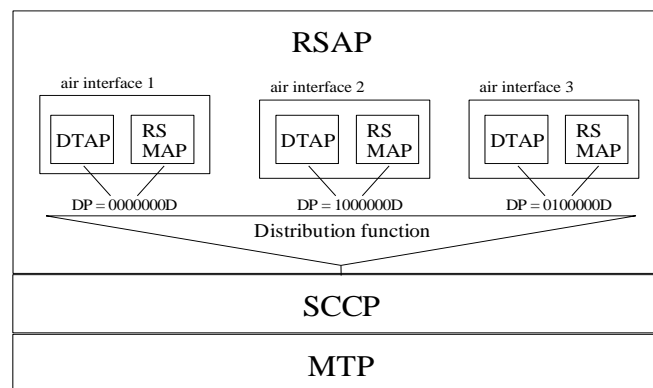

Figure 2a: Distribution of message groups according to examples of the air interface types

9.3.2 Transfer of DTAP messages

The DTAP function is in charge of transferring layer 3 messages from the MS (resp from the MSC) to the MSC (resp to the MS) without any analysis of the message contents. The interworking between the layer 2 protocol on the radio side and signalling system 7 at the landside is based on the use of individual SCCP connections for each MS and on the distribution function.

The structure of the user data field is given in figure 3. The user data field contains a distribution data unit, a length indicator, and the actual layer 3 message.

The Distribution Data Unit consists of two parameters: the Discrimination parameter and the Data Link Connection Identification (DLCI) parameter.

The Discrimination parameter, which is set to the "Transparent" value, is coded on one octet, as follows:

8	7	6	5	4	3	2	1
0	0	0	0	0	0	0	D

The discrimination bit D is set to the "Transparent" value 1.

The DLCI parameter is used for MSC to BSS messages to indicate the type of data link connection to be used over the radio interface. In the direction BSS to MSC the DLCI parameter is used to indicate the type of originating data link connection over the radio interface. The DLCI parameter is coded in one octet, as follows:

8	7	6	5	4	3	2	1
C2	C1	0	0	0	S3	S2	S1

C2 C1 represents the control channel identification;
 C2=0; C1=0 indicates that the control channel is not further specified;
 C2=1; C1=0 represents the FACCH or the SDCCH;
 C2=1; C1=1 represents the SACCH;
 other values are reserved.

S3 S2 S1 represents the SAPI value used on the radio link, which coding is specified in 3GPP TS 44.006.

Bits 4, 5 and 6 are spare.

The length indicator is coded in one octet, and is the binary representation of the number of octets of the subsequent layer 3 message parameter.

9.3.3 Transfer of BSSMAP messages

The transfer of BSSMAP messages over a SCCP connection allows the BSSMAP functions in both the MSC and the BSS to identify to which particular Mobile Station association the exchanged message (e.g. assign, handover request, etc..) applies.

The structure of the user data field is given in figure 3. The user data field contains a distribution data unit, a length indicator, and the actual layer 3 message.

The Distribution Data Unit only consists of the Discrimination parameter, which is set to the "Not Transparent" value.

This parameter is coded on one octet, as follows:

8	7	6	5	4	3	2	1
0	0	0	0	0	0	0	D

The discrimination bit D is set to the "Not Transparent" value 0.

The length indicator is coded in one octet, and is the binary representation of the number of octets of the subsequent layer 3 message parameter.

The coding of the BSSMAP layer 3 messages is specified in 3GPP TS 48.008.

9.4 Connectionless services

Some BSSMAP procedures described in 3GPP TS 48.008 use the connectionless services of the SCCP.

The structure of the user data field of the unit data message (UDT) is given in figure 3. The user data field contains a distribution data unit, a length indicator, and the actual layer 3 message.

The Distribution Data Unit only consists of the Discrimination parameter, which is set to the "Not Transparent" value.

9.4.1 Discrimination parameter (ITU-T Recommendation)

This parameter is coded on one octet, as follows:

8	7	6	5	4	3	2	1
0	0	0	0	0	0	0	D

The discrimination bit D is set to the "Not Transparent" value 0.

The length indicator is coded in one octet, and is the binary representation of the number of octets of the subsequent layer 3 message parameter.

The coding of the BSSMAP layer 3 messages is specified in 3GPP TS 48.008.

9.4.2 Discrimination parameter (ANSI Specification)

This parameter is coded on one octet, as follows:

8	7	6	5	4	3	2	1
X	x	X	x	x	x	x	D

The discrimination bit D is set to the "BSSMAP" value 0.

The bits indicated with X values denote to air interface message groups as shown in the table "Coding Of The Discrimination Parameter for PCS 1900" (see clause 9.3.2.2).

The length indicator is coded in one octet, and is the binary representation of the number of octets of the subsequent layer 3 message parameter.

9.4.3 User Data Field Structure

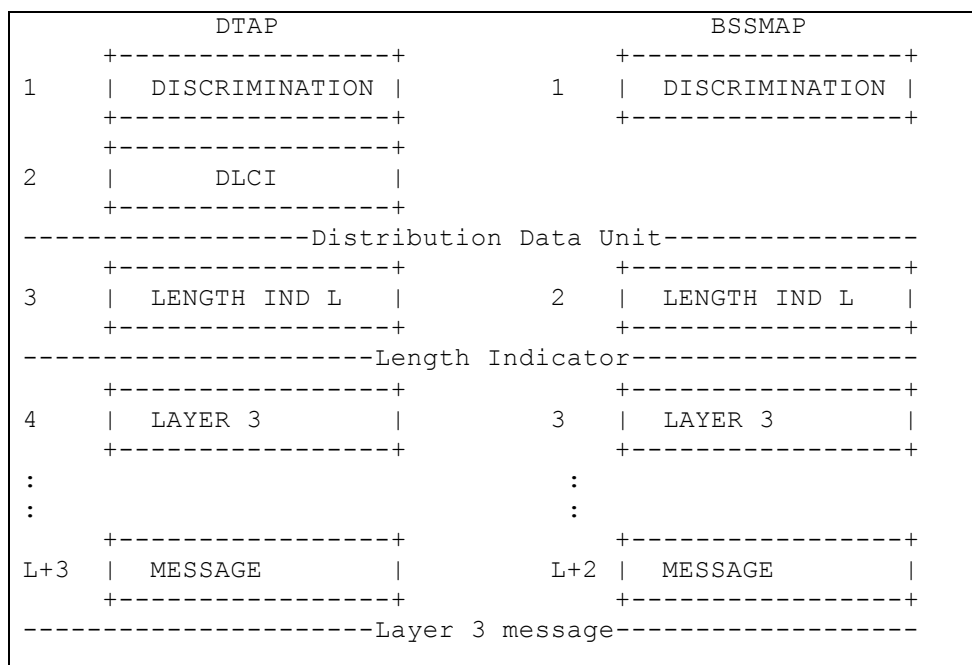

Figure 3: Structure of the User Data Field

10 Use of the SCCP for operations and maintenance

O&M messages have to be passed between the O&M functions and the BSS.

If the O&M functions use the MSC-BSS interface to transport messages to the BSS, then the SCCP of No.7 should be used.

X25 may also be used for the transfer of O&M messages between BSS and OMC, this is not further considered in the present document.

10.1 Connectionless service

The connectionless service of the SCCP is supported at the BSS for management purposes and can be used for the transport of O&M information. Addressing should be decided by the operator and manufacturer (e.g. by E164 number, this may require additional addressing capability at the BSS).

Further information is given concerning the coding of the higher levels of the O&M information in the 3GPP TS 12.xx series of Technical Specifications.

10.2 Connection oriented services

Connection oriented services are also supported by the BSS for management and call control. Connection oriented services can also be used for the transport of O&M information. In order to set up the connection additional addressing capability may be required at the BSS. To use a signalling connection between the BSS and the OMC via the MSC requires the same BSSOMAP-SCCP interface at both the BSS and the OMC.

10.3 BSS failure

If a system failure at the BSS occurs then sufficient MTP functions to allow message transmission and reception should be maintained.

Annex A (informative): Change History

TSG#	TSG Doc.	CR	Rev	Subject/Comment	New
September 2012	-	-	-	Version 11.0.0 based on version 10.0.0	11.0.0