

# 3GPP TR 45.902 V11.0.0 (2012-09)

---

*Technical Report*

## **3rd Generation Partnership Project; Technical Specification Group GSM/EDGE Radio Access Network; Flexible Layer One (FLO) (Release 11)**



The present document has been developed within the 3<sup>rd</sup> Generation Partnership Project (3GPP™) and may be further elaborated for the purposes of 3GPP.

The present document has not been subject to any approval process by the 3GPP Organizational Partners and shall not be implemented. This Specification is provided for future development work within 3GPP only. The Organizational Partners accept no liability for any use of this Specification. Specifications and reports for implementation of the 3GPP™ system should be obtained via the 3GPP Organizational Partners' Publications Offices.

---

Keywords

---

GSM, GERAN, mux, radio, layer 1

**3GPP**

Postal address

---

3GPP support office address

---

650 Route des Lucioles - Sophia Antipolis  
Valbonne - FRANCE  
Tel.: +33 4 92 94 42 00 Fax: +33 4 93 65 47 16

Internet

---

<http://www.3gpp.org>

---

**Copyright Notification**

No part may be reproduced except as authorized by written permission.  
The copyright and the foregoing restriction extend to reproduction in all media.

© 2012, 3GPP Organizational Partners (ARIB, ATIS, CCSA, ETSI, TTA, TTC).  
All rights reserved.

UMTS™ is a Trade Mark of ETSI registered for the benefit of its members  
3GPP™ is a Trade Mark of ETSI registered for the benefit of its Members and of the 3GPP Organizational Partners  
LTE™ is a Trade Mark of ETSI currently being registered for the benefit of its Members and of the 3GPP Organizational Partners  
GSM® and the GSM logo are registered and owned by the GSM Association

# Contents

Foreword .....	5
Introduction .....	5
1 Scope .....	6
2 References.....	6
3 Definitions, symbols and abbreviations .....	6
3.1 Definitions .....	6
3.2 Abbreviations .....	7
4 Motivation .....	8
5 Requirements .....	8
6 Overview of FLO.....	9
6.1 General .....	9
6.2 Principles of FLO .....	9
6.3 Evolution from Release 5 .....	9
6.4 Limitations .....	10
6.5 Protocol architecture .....	10
6.5.1 <i>Iu</i> mode .....	10
6.5.2 <i>A/Gb</i> mode .....	11
6.5.3 TBF configuration principles .....	11
7 Layer 1 for FLO.....	11
7.1 CRC Attachment.....	12
7.2 Channel Coding .....	13
7.3 Rate Matching .....	13
7.4 Transport Channel Multiplexing .....	16
7.4a Inband signalling bits .....	16
7.5 Transport Format Combination Identifier (TFCI) .....	16
7.6 Interleaving .....	17
7.7 Signalling on HR Channels.....	18
8 Layer 2 for FLO.....	19
8.1 Protocol architecture in <i>Iu</i> mode .....	19
8.1.1 General.....	19
8.1.2 RLC protocol .....	20
8.1.3 MAC protocol.....	20
8.2 Protocol architecture in <i>A/Gb</i> mode .....	20
8.3 RLC/MAC block structure.....	20
8.3.1 General.....	20
8.3.2 RLC/MAC blocks for control message transfer .....	21
8.3.2.1 Downlink RLC/MAC control block format .....	21
8.3.2.2 Uplink RLC/MAC control block format .....	21
8.3.3 RLC/MAC blocks for data transfer.....	21
8.3.3.1 Downlink RLC/MAC block for data transfer .....	21
8.3.3.1.1 RLC unacknowledged mode .....	21
8.3.3.1.2 RLC acknowledged mode .....	22
8.3.3.1.3 RLC transparent mode .....	22
8.3.3.2 Uplink RLC/MAC block for data transfer.....	22
8.3.3.2.1 RLC unacknowledged mode .....	22
8.3.3.2.2 RLC acknowledged mode .....	22
8.3.3.2.3 RLC transparent mode .....	23
8.4 Ciphering in <i>Iu</i> mode .....	23
8.4.1 General.....	23
8.4.2 Parameters settings.....	23
8.4.2.1 RLC non-transparent mode .....	23

8.4.2.2	RLC transparent mode .....	23
8.4.2.3	RLC/MAC control messages .....	24
8.5	TFC Selection.....	24
8.5.1	TFC selection in the uplink .....	24
8.5.2	TFC selection in the downlink .....	24
8.6	Ciphering in <i>A/Gb mode</i> .....	24
9	Layer 3 for FLO.....	25
9.1	In <i>Iu mode</i> .....	25
9.2	In <i>A/Gb mode</i> .....	25
9.3	Transport and physical channel configuration .....	25
9.4	Calculated Transport Format Combination .....	26
9.4.1	Definition .....	26
9.4.2	Example .....	27
9.5	TFC for Signalling .....	28
9.6	TBF configuration .....	28
10	Testing of FLO .....	28
11	Impact on Specifications .....	29
<b>Annex A (informative): Block Codes for the TFCI.....</b>		<b>30</b>
<b>Annex B (informative): Header fields.....</b>		<b>32</b>
B.1	Payload Type (PT) field .....	32
B.2	Polling (P) bit .....	32
B.3	Segmentation (S) bit.....	32
B.4	Reduced Block Sequence Number (RBSN) bit .....	32
B.5	Radio Transaction Identifier (RTI) field .....	32
B.6	Temporary Flow Identity (TFI) field .....	33
B.7	Block Sequence Number (BSN) field .....	33
B.7.1	General.....	33
B.7.2	RLC unacknowledged mode .....	33
B.7.3	RLC acknowledged mode.....	33
B.8	Split Block Indicator (SPB) field .....	33
B.9	Stall Indicator (SI) field .....	33
B.10	Extension (E) bit .....	33
B.11	Length Indicator (LI) field .....	34
<b>Annex C: Change history.....</b>		<b>35</b>

---

## Foreword

This Technical Report has been produced by the 3<sup>rd</sup> Generation Partnership Project (3GPP).

The contents of the present document are subject to continuing work within the TSG and may change following formal TSG approval. Should the TSG modify the contents of the present document, it will be re-released by the TSG with an identifying change of release date and an increase in version number as follows:

Version x.y.z

where:

- x the first digit:
  - 1 presented to TSG for information;
  - 2 presented to TSG for approval;
  - 3 or greater indicates TSG approved document under change control.
- y the second digit is incremented for all changes of substance, i.e. technical enhancements, corrections, updates, etc.
- z the third digit is incremented when editorial only changes have been incorporated in the document.

---

## Introduction

A new type of physical layer is proposed for the GSM/EDGE Radio Access Network (GERAN): the flexible layer one (FLO). The main advantage of FLO is that the configuration of the physical layer (e.g. channel coding and interleaving) is specified at call setup. This means that the support of new services such as IP Multimedia Subsystem (IMS) services can be handled smoothly without having to specify new coding schemes in each release.

Through several enhancements such as reduced granularity and flexible interleaving, the radio bearers offered by FLO would not only fulfil the IMS requirements in terms of flexibility and performance, but also greatly improve the link level performance of real-time IMS services compared to GERAN Release 5.

The objective of this TR is to provide an overview of FLO, its architecture and study the impacts it has on the GERAN radio protocol stack.

---

# 1 Scope

The present document provides an overview of the flexible layer one, its architecture and studies the impacts it has on the GERAN radio protocol stack.

---

# 2 References

The following documents contain provisions, which, through reference in this text, constitute provisions of the present document.

- References are either specific (identified by date of publication, edition number, version number, etc.) or non-specific.
- For a specific reference, subsequent revisions do not apply.
- For a non-specific reference, the latest version applies. In the case of a reference to a 3GPP document (including a GSM document), a non-specific reference implicitly refers to the latest version of that document *in the same Release as the present document*.

- [1] 3GPP TR 21.905: “Vocabulary for 3GPP Specifications”.
- [2] 3GPP TS 22.101, “Service Principles”.
- [3] 3GPP TS 22.228, “Service requirements for the IP Multimedia Core Network Subsystem”.
- [4] 3GPP TS 23.107, “QoS Concept and Architecture”.
- [5] 3GPP TS 23.228, “IP Multimedia Subsystem”.
- [6] 3GPP TS 25.201, “Physical layer - General description”.
- [7] 3GPP TS 25.212, “Multiplexing and channel coding (FDD)”.
- [8] 3GPP TS 25.331, “RRC Protocol Specification”.
- [9] 3GPP TS 32.201, “Specification of the 3GPP Confidentiality and Integrity Algorithms”.
- [10] 3GPP TS 44.018: “Radio Resource Control protocol”.
- [11] 3GPP TS 44.118: “Radio Resource Control protocol, Iu mode”.
- [12] 3GPP TS 44.060: “Radio Link Control/Medium Access Control protocol”.
- [13] 3GPP TS 44.160: “Radio Link Control/Medium Access Control protocol, Iu mode”.
- [14] 3GPP TS 45.002: “Multiplexing and multiple access on the radio path”.
- [15] 3GPP TS 45.003: “Channel Coding”.
- [16] 3GPP TS 45.005: “Radio transmission and reception”.

---

# 3 Definitions, symbols and abbreviations

## 3.1 Definitions

For the purposes of the present document, the following terms and definitions apply.

**Active Transport Channel:** a transport channel is active during a TTI if it carries a transport block.

**Dynamic attributes:** for one transport channel, the values of the dynamic attributes are different among transport formats. They are configured by Layer 3 and can change on a TTI basis under the control of the MAC sublayer.

**Empty Transport Format:** a transport format such that no transport block is carried over the transport channel (i.e. the transport channel is inactive).

**Empty Transport Format Combination:** a transport format combination that is made up only of empty transport formats.

**Inactive Transport Channel:** a transport channel is inactive during a TTI if it does not carry a transport block (i.e. the transport block size is zero).

**Radio Frame:** The result of applying rate matching to a transport block along with its associated CRC that have first been channel encoded.

**Radio Packet:** The set of one or more radio frames together with the applicable coded TFCI that form the volume of payload that can be transmitted on a basic physical subchannel for any given TTI.

**Semi-static attributes:** for one transport channel, the values of the semi-static attributes are common to all transport formats. They are configured by Layer 3 and can only be changed by Layer 3 signalling.

**Transport Block:** block exchanged on a transport channel between the physical layer and the MAC sublayer.

**Transport Channel:** SAP between the physical layer and the MAC sublayer.

**Transport Format:** configuration of a transport channel, including for instance channel coding, CRC size, etc.

**Transport Format Combination:** allowed combination of transport format(s) of the different transport channels that are multiplexed together on a basic physical subchannel.

**Transport Format Combination Indicator:** layer one header that indicates the transport format combination that has been selected for each radio packet.

**Transport Format Combination Set:** set of allowed transport format combinations on a basic physical subchannel.

**Transport Format Indicator:** index identifying a particular transport format within the transport format set.

**Transport Format Set:** set of all transport formats defined for a particular transport channel.

**Transmission Time Interval:** rate at which transport blocks are exchanged between the physical layer and the MAC sublayer on a transport channel.

## 3.2 Abbreviations

For the purposes of the present document, the following abbreviations apply:

ADCH	Associated Dedicated CHannel
CCTrCH	Coded Composite Transport CHannel
CDCH	Control-plane Dedicated CHannel
CTFC	Calculated Transport Format Combinations
DCH	Dedicated CHannel
FLO	Flexible Layer One
GERAN	GSM/EDGE Radio Access Network
IMS	IP Multimedia Subsystem
MAC	Medium Access Control
QoS	Quality of Service
PDU	Protocol Data Unit
RAN	Radio Access Network
RLC	Radio Link Control
RRC	Radio Resource Control
RT	Real Time
SDU	Service Data Unit
SAP	Service Access Point
TB	Transport Block

TBF	Temporary Block Flow
TF	Transport Format
TFI	Temporary block Flow Identity
TFS	Transport Format Set
TFIN	Transport Format INdicator
TFC	Transport Format Combination
TFCI	Transport Format Combination Indicator
TFCS	Transport Format Combination Set
TrCH	Transport Channel
TTI	Transmission Time Interval
UDCH	User-plane Dedicated CHannel
UTRAN	Universal Terrestrial Radio Access Network

Other abbreviations used in the present document are listed in 3GPP TR 21.905.

---

## 4 Motivation

The need for a flexible layer one for the Release 6 of GERAN is driven by the introduction of IMS services. For an efficient support of IMS services, requirements are set on the radio bearer service of the RAN (see 3GPP TS 22.101, 3GPP TS 22.228, 3GPP TS 23.228 and 3GPP TS 23.107):

- the radio bearers should be flexible enough to efficiently deploy any IP multimedia applications;
- the radio bearers should allow the transport of several flows in parallel (e.g. text and video);
- the radio bearers should satisfy the user in a spectral efficient manner;
- the radio bearer should support the UMTS QoS concept and architecture.

So as to fulfil these requirements in an efficient manner, a flexible layer one is needed. Thanks to the flexible layer one optimised support of real time IMS services is made possible in GERAN.

---

## 5 Requirements

The flexible layer one should:

- fulfil most of the IMS requirements in terms of radio bearer service attributes;
- support the multiplexing of parallel flows on to a basic physical subchannel;
- provide an optimisation of spectral efficiency through the support of different interleaving depths, unequal error protection/detection, reduced channel coding rate granularity and support of 8PSK and GMSK modulations;
- provide an efficient support of real time IMS services;
- be applicable to both modes of operation: *A/Gb mode* and *Iu mode*;
- minimize the impacts on the radio protocols;
- minimize the overhead introduced by the radio protocol stack;
- not introduce an unfeasible number of test configurations;
- be future proof;
- within reason, be compatible with legacy transceiver implementations.



---

## 6 Overview of FLO

### 6.1 General

In GERAN Release 5, the MAC sublayer is responsible for the mapping between the logical channels (traffic or control channels) and the basic physical channels (see 3GPP TS 45.002). The logical channels are the channels the physical layer offers to the MAC sublayer. Until now these logical channels and the mapping to the basic physical channel have been fully specified in 3GPP TS 45.002.

A different approach has been taken in UTRAN, where instead of providing logical channels the physical layer offers Transport Channels (TrCH), which can be used by the MAC sublayer (see 3GPP TS 25.201). A transport channel is used to transmit one data flow with a given QoS over the radio interface. A number of transport channels can be active at the same time and multiplexed at the physical layer. The transport channels are configured at call setup by the network.

With FLO, the concept of transport channels used in UTRAN can be reused in GERAN i.e. the physical layer offers one or several transport channels to the MAC sublayer.

### 6.2 Principles of FLO

With FLO, the physical layer of GERAN offers one or several transport channels to the MAC sublayer. Each of these transport channels can carry one data flow providing a certain Quality of Service (QoS). A number of transport channels can be multiplexed and sent on the same basic physical subchannel at the same time.

The configuration of a transport channel i.e. the number of input bits, channel coding, interleaving etc. is denoted the Transport Format (TF). As in UTRAN, a number of different transport formats can be associated to one transport channel. The configuration of the transport formats is completely controlled by the RAN and signalled to the MS at call setup. In both the MS and the BTS, the transport formats are used to configure the encoder and decoder units. When configuring a transport format, the RAN can choose between a number of predefined CRC lengths and block lengths.

On transport channels, transport blocks (TB) are exchanged between the MAC sublayer and the physical layer on a transmission time interval (TTI) basis. For each TTI a transport format is chosen and indicated through the transport format indicator (TFIN). In other words, the TFIN tells which transport format to use for that particular transport block on that particular TrCH during that particular TTI. When a transport channel is inactive, the transport format with a transport block size of zero (empty transport format) is selected.

Only a limited number of combinations of the transport formats of the different TrCHs are allowed. A valid combination is called a Transport Format Combination (TFC). The set of valid TFCs on a basic physical subchannel is called the Transport Format Combination Set (TFCS). The TFCS is signalled through the Calculated Transport Format Combinations (CTFC).

In order to decode the received sequence the receiver needs to know the active TFC for a radio packet. This information is transmitted in the Transport Format Combination Indicator (TFCI) field. This field is basically a layer 1 header and has the same function as the stealing bits in GSM. Each of the TFC within a TFCS are assigned a unique TFCI value and when a radio packet is received this is the first to be decoded by the receiver. From the decoded TFCI value the transport formats for the different transport channels are known and the actual decoding can start.

In case of multislot operation, there shall be one FLO instance for each basic physical subchannel. Each FLO instance is configured independently by Layer 3 and as a result gets its own TFCS. The number of allocated basic physical subchannels depends on the multislot capabilities of the MS.

### 6.3 Evolution from Release 5

In GERAN Release 5, logical channels are offered by the physical layer to the MAC sublayer. With FLO, transport channels are offered by the physical layer to the MAC sublayer.

In GERAN Release 5, speech frames, RLC/MAC blocks, data frames and blocks of info bits are exchanged on logical channels between the physical layer and the MAC sublayer. With FLO, transport blocks are exchanged on transport channels between the physical layer and the MAC sublayer.

In GERAN Release 5, a fixed set of coding schemes are standardized for each logical channel in 3GPP TS 45.003. With FLO, transport formats are configured at call setup for each transport channel.

In GERAN Release 5, only one logical channel can be sent per radio block. With FLO, the transport format combinations allow a number of transport channels to be multiplexed within the same radio block.

In GERAN Release 5, the coding scheme and/or the content of the radio block is indicated by the stealing bits. With FLO, the TFC and thereby the active transport formats of the TrCHs is indicated by the TFCI.

## 6.4 Limitations

The following assumptions are made in order to limit the complexity of FLO:

- FLO shall be used on dedicated channels only, maintaining the 26-multiframe structure for which the SACCH shall be treated as a separate logical channel based on Release 5 format;
- All TrCHs shall use the same TTI: the same length as in GSM/GPRS of Release 5, i.e. 20ms;
- FLO shall provide at most 8 transport channels per basic physical subchannel;
- FLO shall support a maximum of 4 active transport channels per radio packet per basic physical subchannel;
- The size of the TFCI shall be limited to 5 bits, allowing a maximum of 32 different TFCs per basic physical subchannel;
- A maximum of 32 different TFs is allowed per TrCH;
- One RLC PDU cannot be mapped across multiple basic physical subchannels.

## 6.5 Protocol architecture

### 6.5.1 Iu mode

Figure 1 below illustrates the protocol architecture in conjunction with FLO in *Iu mode*:

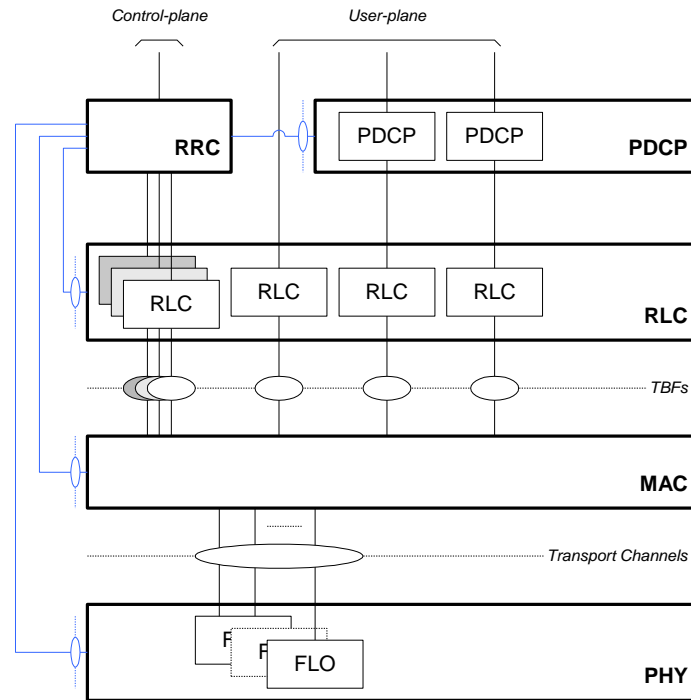

**Figure 1: Protocol Architecture for FLO in *lu mode***

The physical layer offers transport channels to the MAC sublayer. MAC is responsible for mapping temporary block flows (see 3GPP TS 44.160) on appropriate transport channels.

One type of transport channel is introduced: Dedicated CHannel (DCH). A DCH is a unidirectional channel dedicated to one MS used in uplink or downlink. A mobile station may have one or more TrCHs of type DCH active at the same time.

### 6.5.2 A/Gb mode

Text will be added when FLO concepts for A/Gb mode have stabilized.

### 6.5.3 TBF configuration principles

Each TBF is mapped to 1 transport channel per each timeslot assigned to the TBF (see subclause 6.4) for sending RLC data blocks. When a TBF is assigned multiple timeslots, the transport channels used by the TBF shall be configured with the same Transport Format Set. RLC/MAC control blocks are transmitted using the signalling TFC.

On a timeslot, several TBFs may be multiplexed onto the same transport channel. In this case, the receiver identifies which TBF a transport block belongs to by means of the TFI field or a radio bearer identifier.

## 7 Layer 1 for FLO

The architecture of FLO is depicted in the Figure 2 below. A one-step interleaving has been assumed. This implies that all TrCHs on one basic physical subchannel have the same interleaving depth.

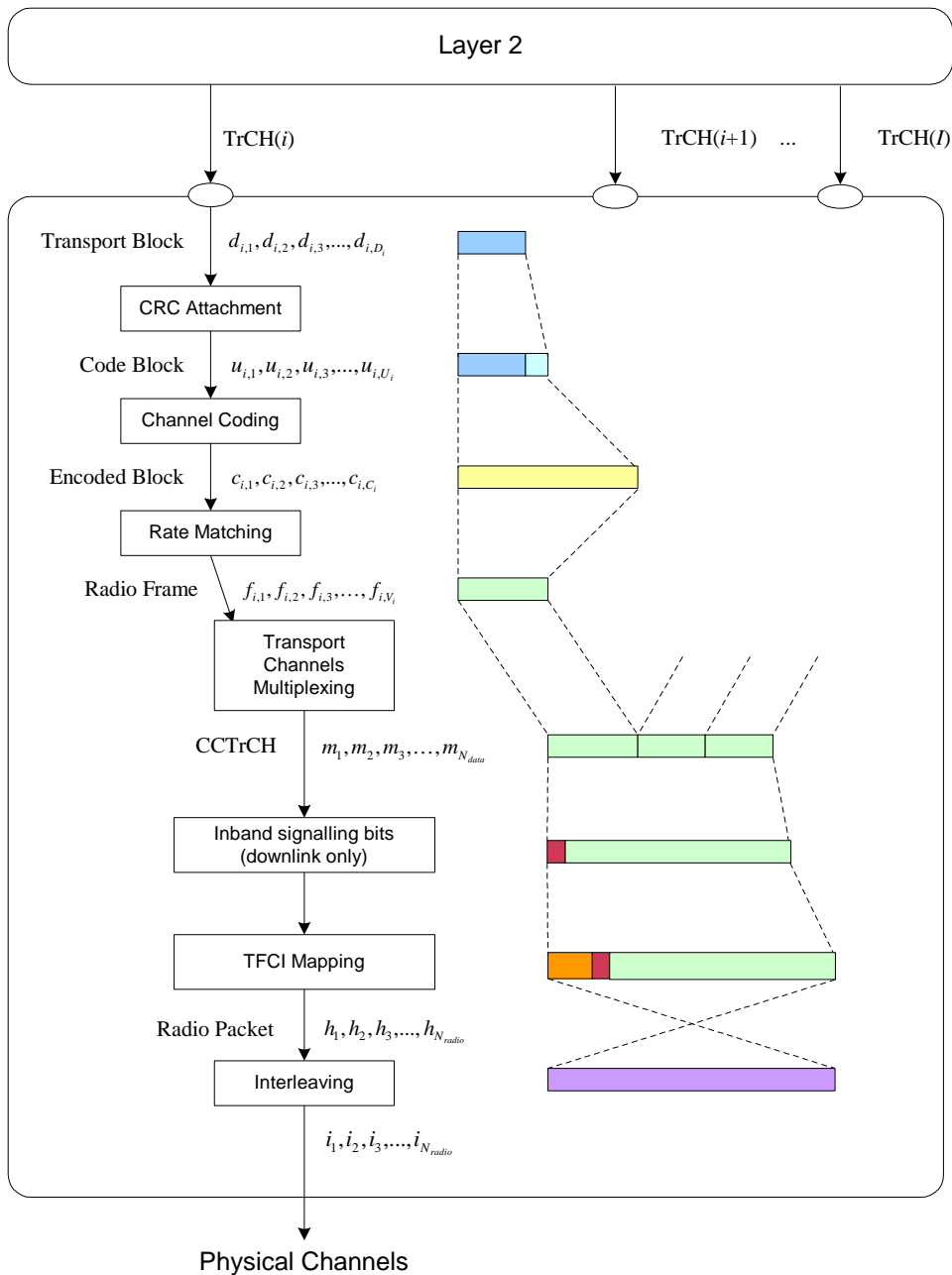

Figure 2: FLO Architecture

## 7.1 CRC Attachment

Error Detection is provided on each transport block through a cyclic redundancy check (CRC). The size of the CRC to be used is fixed on each TrCH and configured by Layer 3 (semi static attribute of the transport format): 0, 6, 12 or 18 bits. Code blocks are output from the CRC attachment. The entire transport block is used to calculate the parity bits. The parity bits are generated by one of the following cyclic generator polynomials, and appended to the transport block:

- $gCRC18(D) = D^{18} + D^{17} + D^{14} + D^{13} + D^{11} + D^{10} + D^8 + D^7 + D^6 + D^3 + D^2 + 1$  as in SACCH/TP
- $gCRC12(D) = D^{12} + D^{11} + D^{10} + D^8 + D^5 + D^4 + 1$  as in GPRS
- $gCRC6(D) = D^6 + D^5 + D^3 + D^2 + D + 1$  as in TCH/AFS

The resulting upper limits for the residual bit error rate (RBER), listed in Table 1 below, fulfil the QoS requirements specified in 3GPP TS 23.107.

Table 1: RBER

CRC Size	RBER
6 bits	$2 \cdot 10^{-2}$
12 bits	$2 \cdot 10^{-4}$
18 bits	$4 \cdot 10^{-6}$

## 7.2 Channel Coding

After CRC attachment, the code blocks are processed through channel coding, producing encoded blocks.

Only one type of coding is proposed for use in Release 6, the same 1/3 convolutional code of constraint length 7 as in EGPRS, defined by the following polynomials (see 3GPP TS 45.003):

$$G4 = 1 + D^2 + D^3 + D^5 + D^6$$

$$G7 = 1 + D + D^2 + D^3 + D^6$$

$$G5 = 1 + D + D^4 + D^6$$

## 7.3 Rate Matching

The rate matching is the core of FLO. In rate matching, bits of an encoded block on a transport channel are repeated or punctured. Since the block size is a dynamic attribute, the number of bits on a transport channel can vary between different transmission times. When it happens, bits are repeated or punctured to ensure that the total bit rate after TrCH multiplexing is identical to the total channel bit rate of the allocated basic physical subchannel.

When only one transport channel is active at a time, the coding rate only depends on the transport block size and on the available channel bandwidth. But when more than one transport channel is active, the coding rate also depends on the rate matching attributes associated to each transport channel. The rate-matching attribute is used to calculate the number of bits to be repeated or punctured for each transport channel.

Higher layers assign the rate matching attribute for each transport channel. This attribute is semi-static and can only be changed through higher layer signalling. The rate matching attributes define priorities between the coded bits of different transport channels. The higher the rate matching attribute is, the more important the coded bits are. By setting different rate matching attributes to different transport channels, the effective coding rate (as a result of puncturing or repeating bits of an encoded block) of the transport channels can be adjusted.

Outputs from the rate matching are called radio frames. For every radio packet the rate matching produces one radio frame per encoded block, i.e. per TrCH.

The rate matching algorithm for GERAN is based on the UTRAN one defined in 3GPP TS 25.212. A few simplifications are made since there is no spreading factor, nor compressed mode, nor special cases such as turbo codes and therefore many parameters of the UTRAN algorithm can be fixed either to 0 or 1 in GERAN.

Notation used:

$\lfloor x \rfloor$  Round  $x$  towards  $-\infty$ , i.e. integer such that  $x - 1 < \lfloor x \rfloor \leq x$ .

$|x|$  Absolute value of  $x$ .

$I$  Number of TrCHs in the coded composite transport channel (CCTrCH).

$N_{data}$  Total number of bits that are available in a radio packet for the CCTrCH.

$N_{i,j}$  Number of bits in an encoded block before rate matching on TrCH  $i$  with transport format combination  $j$ .

$\Delta N_{i,j}$  If positive,  $\Delta N_{i,j}$  denotes the number of bits that have to be repeated in an encoded block on TrCH  $i$  with transport format combination  $j$  in order to produce a radio frame.

If negative,  $\Delta N_{i,j}$  denotes the number of bits that have to be punctured in an encoded block on TrCH  $i$  with transport format combination  $j$  in order to produce a radio frame.

If null, no bits have to be punctured nor repeated, i.e. the rate matching is transparent and the content of the radio frame is identical to the content of the encoded block on TrCH  $i$  with transport format combination  $j$ .

$RM_i$  Semi-static rate matching attribute for transport channel  $i$ .

$e_{ini}$  Initial value of variable  $e$  in the rate matching pattern determination algorithm.

$e_{plus}$  Increment of variable  $e$  in the rate matching pattern determination algorithm.

$e_{minus}$  Decrement value of variable  $e$  in the rate matching pattern determination algorithm.

$Z_{i,j}$  Intermediate calculation variable.

$R$  Redundancy pattern index used for retransmissions of signalling transport blocks on half rate channels (see subclause 7.5). In all other cases  $R = 0$ .

For each radio packet using transport format combination  $j$ , the number of bits to be repeated or punctured  $\Delta N_{i,j}$  within one encoded block for each TrCH  $i$  is calculated with the following equations:

$$Z_{0,j} = 0$$

$$Z_{i,j} = \left[ \frac{\left( \sum_{m=1}^i RM_m \times N_{m,j} \right) \times N_{data}}{\sum_{m=1}^I RM_m \times N_{m,j}} \right] \quad \text{for all } i = 1 \dots I$$

$$\Delta N_{i,j} = Z_{i,j} - Z_{i-1,j} - N_{i,j} \quad \text{for all } i = 1 \dots I$$

For the calculation of the rate matching pattern of each TrCH  $i$  the following relations are defined:

$$e_{plus} = 2 \times N_{i,j}$$

$$e_{minus} = 2 \times |\Delta N_{i,j}|$$

if  $\Delta N_{i,j} < 0$

$$\text{if } \frac{e_{plus}}{e_{minus}} \geq 2$$

$$d = \frac{e_{plus}}{e_{minus}} = \frac{N_{i,j}}{|\Delta N_{i,j}|} \quad \text{-- average distance between punctured bits}$$

$$e_{ini} = 1 + (R \bmod \lceil d \rceil) \times e_{minus}$$

else

$$d = \frac{e_{plus}}{e_{plus} - e_{minus}} = \frac{N_{i,j}}{N_{i,j} - |\Delta N_{i,j}|} \quad \text{-- average distance between transmitted bits}$$

$$e_{ini} = 1 + (R \bmod \lceil d \rceil) \times (e_{plus} - e_{minus})$$

end if

else  $e_{ini} = 1$

The rate matching rule is as follows:

```

if  $\Delta N_{i,j} < 0$            -- puncturing is to be performed
     $e = e_{ini}$              -- initial error between current and desired puncturing ratio
     $m = 1$                  -- index of current bit
    do while  $m \leq N_{i,j}$  -- for each bit of the encoded block of TrCHi
         $e = e - e_{minus}$     -- update error
        if  $e \leq 0$  then    -- check if bit number  $m$  should be punctured
            puncture bit  $b_{im}$  -- bit is punctured
             $e = e + e_{plus}$  -- update error
        end if
         $m = m + 1$         -- next bit
    end do
else if  $\Delta N_{i,j} > 0$     -- repetition is to be performed
     $e = e_{ini}$              -- initial error between current and desired puncturing ratio
     $m = 1$                  -- index of current bit
    do while  $m \leq N_{i,j}$  -- for each bit of the encoded block of TrCHi
         $e = e - e_{minus}$     -- update error
        do while  $e \leq 0$  -- check if bit number  $m$  should be repeated
            repeat bit  $b_{i,m}$  -- repeat bit
             $e = e + e_{plus}$  -- update error
        end do
         $m = m + 1$         -- next bit
    end do
else                       --  $\Delta N_{i,j} = 0$ 
    do nothing              -- no repetition nor puncturing
end if.

```

## 7.4 Transport Channel Multiplexing

For every radio packet to be transmitted, one radio frame from each active TrCH is delivered to the TrCH multiplexing. These radio frames are serially multiplexed to form a CCTrCH. The order in which each radio frame is multiplexed is determined by the number of the associated TrCH (which is assigned during TrCH configuration).

### 7.4a Inband signalling bits

In the downlink direction, inband signalling bits (used to control the TFC selection algorithm in the MS, see subclause 8.5) are attached at the beginning of the CCTrCH.

The inband signalling bits are used to transmit a TFCI sequence. The number of coded inband signalling bits in each radio packet is equal to the size of the coded uplink TFCI. For each channel type, its value is derived from the size of the uncoded uplink TFCI (which is dependent on the number of TFCs in the uplink TFCS) following the rules in subclause 7.5.

## 7.5 Transport Format Combination Identifier (TFCI)

The size of the TFCI depends on the number of TFCs needed. The smaller this is, the shorter the TFCI is in order to minimize the overhead over the radio interface. The size of the TFCI is however limited to a maximum of 5 bits, allowing a maximum of 32 different transport format combinations on the same basic physical subchannel. In other words, for a single connection (without reconfiguration) it is proposed to have a maximum of 32 different channel coding and/or multiplexing possibilities at a time.

For the coding of the TFCI, simple block codes can be used, as already used for the stealing bits and the USF in 3GPP TS 45.003.

On GMSK full rate channels and 8PSK half rate channels, the coding of the TFCI shall be as follows (see Annex A):

- 1 bit TFCI shall be encoded to 8 bits;
- 2 bits TFCI shall be encoded to 16 bits;
- 3 bits TFCI shall be encoded to 24 bits;
- 4 bits TFCI shall be encoded to 28 bits;
- 5 bits TFCI shall be encoded to 36 bits.

On 8PSK full rate channels, the coding of the TFCI shall be obtained by repetition of the coding defined for GMSK full rate channels (see Annex A):

- 1 bit TFCI shall be encoded to 16 bits (2 times 8 bits);
- 2 bits TFCI shall be encoded to 32 bits (2 times 16 bits);
- 3 bits TFCI shall be encoded to 48 bits (2 times 24 bits);
- 4 bits TFCI shall be encoded to 56 bits (2 times 28 bits);
- 5 bits TFCI shall be encoded to 72 bits (2 times 36 bits).

On GMSK half rate channels, the coding of the TFCI shall be obtained by using only the middle segment of the coding defined for GMSK full rate channels (see Annex A):

- 1 bit TFCI shall be encoded to 4 bits;
- 2 bits TFCI shall be encoded to 8 bits;
- 3 bits TFCI shall be encoded to 12 bits;
- 4 bits TFCI shall be encoded to 14 bits;
- 5 bits TFCI shall be encoded to 18 bits.



The coded TFCI is then attached at the beginning of the CCTrCH (and, in the downlink direction, before the inband signalling bits) before interleaving.

## 7.6 Interleaving

The coded TFCI and the CCTrCH are interleaved together on bursts. The interleaving can be either block diagonal or block rectangular and is configured at call set-up. The interleaving is based on the following equations:

for  $k = 0, 1, 2, \dots, K-1$

$$b = k \bmod D$$

for block diagonal interleaving:

$$a = \text{GCD}\left(D, \frac{N_{\text{radio}}}{D}\right)$$

$$\text{if } a > 1 \text{ then } s = \text{int}\left[\frac{k}{N_{\text{radio}}/a}\right]$$

else  $s = 0$

$$j = \frac{D}{M} \times \left[ (49 \times (k + s)) \bmod \frac{J}{D/M} \right] + \text{int}\left[\frac{k \bmod D}{M}\right]$$

for block rectangular interleaving:

$$a = \text{GCD}\left(2D, \frac{N_{\text{radio}}}{2D}\right)$$

$$\text{if } a > 1 \text{ then } s = \text{int}\left[\frac{k}{N_{\text{radio}}/a}\right]$$

else  $s = 0$

$$j = \frac{2D}{M} \times \left[ (49 \times (k + s)) \bmod \frac{J}{2D/M} \right] + \text{int}\left[\frac{k \bmod 2D}{M}\right]$$

where:

$j$  is the position of the bit  $k$  within the burst  $b$ ;

$D$  is the interleaving depth in bursts;

$J$  is the burst size in bits;

$K$  is the size of the radio packet in bits ( $K = N_{\text{radio}}$ );

$M$  is the size of the radio packet in bursts ( $M = K / J$ );

$\text{GCD}(m, n)$  is the greatest common divisor of  $m$  and  $n$ .

On 8PSK channels, bit swapping for the coded bits of the TFCI is applied: for every bit  $k$  belonging to the coded TFCI for which  $j$  (the position of the bit  $k$  within the burst  $b$ ) verifies  $(j + 1) \bmod 3 = 0$  (i.e. the coded bit of the TFCI is to be mapped on a weak bit of the 8PSK symbol), the following swap is performed:

if  $(cpt \bmod 2 = 0)$  the bit  $k$  is swapped with bit  $k + 80$

else the bit  $k$  is swapped with bit  $K - 80 + k$

where

$cpt$  is a counter of the swapped bits. The value of  $cpt$  is set to zero before swapping and incremented by 1 after every swapped bit. For the first swapped bit  $cpt = 0$ , for the second swapped bit  $cpt = 1$  and so on.

On full rate GMSK channels  $K = 464$  and  $J = 116$ . On full rate 8PSK channels,  $K = 1392$  and  $J = 348$ .

On half rate GMSK channels,  $K = 232$  and  $J = 116$ . On half rate 8PSK channels,  $K = 696$  and  $J = 348$ .

For diagonal interleaving over 40 ms (used on full rate channels),  $D = 8$ . The result of the interleaving is then a distribution of the reordered bits over 8 bursts, using the even numbered position of the first 4 bursts and the odd positions of the last 4 bursts.

For diagonal interleaving over 40 ms (used on half rate channels),  $D = 4$ . The result of the interleaving is then a distribution of the reordered bits over 4 blocks, using the even numbered position of the first 2 bursts and the odd positions of the last 2 bursts.

For diagonal interleaving over 60 ms (used on full rate channels),  $D = 12$ . The result of the interleaving is then a distribution of the reordered bits over 12 bursts, allocating one third of the bits to each of three consecutive radio packets.

For diagonal interleaving over 60 ms (used on half rate channels),  $D = 6$ . The result of the interleaving is then a distribution of the reordered bits over 6 bursts, allocating one third of the bits to each of three consecutive radio packets.

For block rectangular interleaving over 20 ms (used on full rate channels),  $D = 4$ . The result is the combination of the first 4 bursts with the 4 last bursts of the result of a block diagonal interleaving over  $2 \times D$  bursts: block 0 and block 4, block 1 and block 5, block 2 and block 6, block 3 and block 7.

Block diagonal interleaving over 60 ms shall be used for 8PSK modulation only.

## 7.7 Signalling on HR Channels

For seamless handovers between full rate and half rate channels the link level performance of associated signalling must be similar for the two channel modes. Consequently the coding rate of associated signalling on half rate channels must be equal to the coding rate of associated signalling on full rate channels. This is achieved in GSM/EDGE by increasing the interleaving depth of FACCH on half rate channels: twice the interleaving depth of TCH/H (see 3GPP TS 45.003). As a result the performance of FACCH/H is very similar to the performance of FACCH/F (see 3GPP TS 45.005).

With the one step interleaving architecture, all TrCHs on one basic physical subchannel have the same interleaving depth. It is therefore not possible to apply the same mechanisms as in GSM/EDGE on CDCH and ADCH. Instead the MAC layer shall send the same transport block twice in a row. Since coded bits of the same transport block can be found in two consecutive radio packets, the effect is as if the interleaving depth was twice the interleaving used for one radio packet. In rate matching, a different value of  $R$  is used for the radio packets. The value of  $R$  to be used by the encoder is given by the TDMA frame number of the first burst carrying coded bits for that radio packet, and table 7.7 below. For instance, if the first coded bits of the signalling radio packet are sent on TDMA frame 0, the value of  $R$  to be used by the encoder is 0. If the first coded bits are sent on TDMA frame 4, the value of  $R$  to be used is 1. Because radio packets are sent on a 20ms basis, the two consecutive signalling radio packets never use the same value of  $R$ .

**Table 7.7:  $R$  and TDMA frame number modulo 26**

TDMA frame number	$R$
0, 1, 2, 3	0
4, 5, 6, 7	1
8, 9, 10, 11	0
13, 14, 15, 16	1
17, 18, 19, 20	0
21, 22, 23, 24	1

## 8 Layer 2 for FLO

### 8.1 Protocol architecture in *lu mode*

#### 8.1.1 General

The MAC sublayer offers TBFs for the transfer of RLC data between peer RLC entities.

One type of TrCH is offered by FLO to the MAC sublayer, DCH, as defined in subclause 6.5.

Three different DCHs are introduced, namely CDCH (Control-plane DCH), UDCH (User-plane DCH) and ADCH (Associated DCH). While CDCH and UDCH are used exclusively for transmission of RLC/MAC blocks for data transfer, ADCH is used exclusively for transmission of RLC/MAC control blocks. CDCH and UDCH shall use the TFC for signalling as defined in sub-clause 9.5.

NOTE: CDCH, UDCH and ADCH naming convention is introduced in order to allow for an easier stage 3 definition of RLC and MAC protocols (e.g. “ADCH” to replace “PACCH”, and “UDCH” to replace “PDTCH”, on DBPSCH)

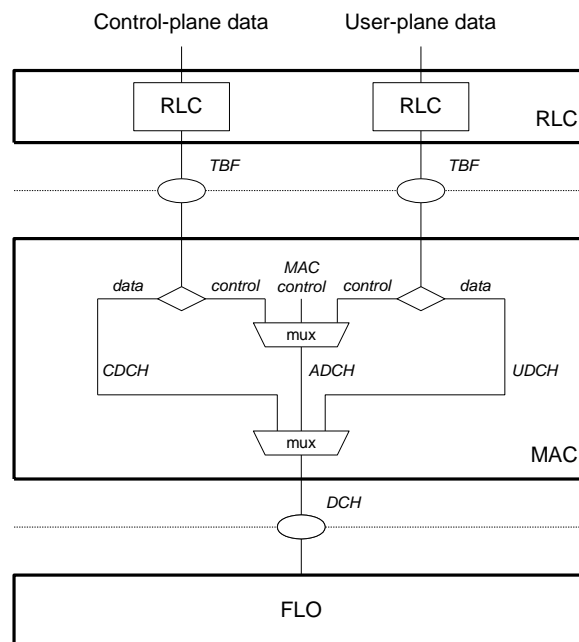

**Figure 3: Logical Channels and Transport Channels**

On a transport channel, a transport block is the basic unit of traffic exchanged between the MAC sublayer and the physical layer.

A transport block consists of a MAC PDU i.e. RLC/MAC block, as shown in Figure 4. The structure of an RLC/MAC block is defined in subclause 8.3.1.



**Figure 4: Transport Block structure**

The number of bits in a transport block is the transport block size.

## 8.1.2 RLC protocol

FLO allows for transmission of RLC information in RLC acknowledged mode, RLC unacknowledged mode and RLC transparent mode.

The functions and services provided by the RLC protocol are defined in 3GPP TS 44.160. No new functions or services are needed to support FLO.

RLC blocks are transferred between two peer RLC entities at a maximum rate of one RLC block per TTI, per timeslot.

## 8.1.3 MAC protocol

The MAC sublayer allows the transmission over the physical layer with FLO of upper layer PDUs from one mobile station on dedicated basic physical subchannel(s). MAC does not allow for operation on shared basic physical subchannel using FLO.

The specific functions provided by the MAC protocol when FLO is used are listed below:

- **Mapping between TBFs and transport channels.** The MAC is responsible for mapping of TBF(s) onto the appropriate transport channel(s).
- **Selection of the appropriate transport format per transport channel.** The MAC is responsible for selecting the appropriate transport format for each transport channel within the transport format set configured by RRC for each transport channel so that the resulting transport format combination on the coded composite transport channel belongs to the transport format combination set configured by RRC.
- **Priority handling between data flows of one MS.**

Other functions provided by the MAC protocol when FLO is used are listed in 3GPP TS 44.160.

## 8.2 Protocol architecture in *A/Gb mode*

Text will be added when FLO concepts for A/Gb mode have stabilized.

## 8.3 RLC/MAC block structure

### 8.3.1 General

An RLC/MAC block consists of either an RLC/MAC block for data transfer or an RLC/MAC block for control message transfer.

In non-transparent RLC mode, the structure of an RLC/MAC block for data transfer consists of an RLC/MAC header and an RLC data block.



**Figure 5: RLC/MAC block structure for data transfer in NT-RLC**

In transparent RLC mode, the structure of an RLC/MAC block for data transfer consists of an RLC data block.

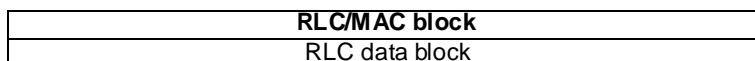

**Figure 6: RLC/MAC block structure for data transfer in T-RLC**

The structure of an RLC/MAC block for control message transfer consists of a MAC header and an RLC/MAC control block.

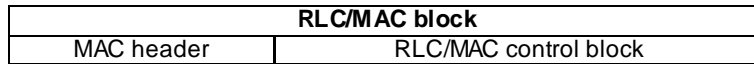

**Figure 7: RLC/MAC block structure for control message transfer**

### 8.3.2 RLC/MAC blocks for control message transfer

#### 8.3.2.1 Downlink RLC/MAC control block format

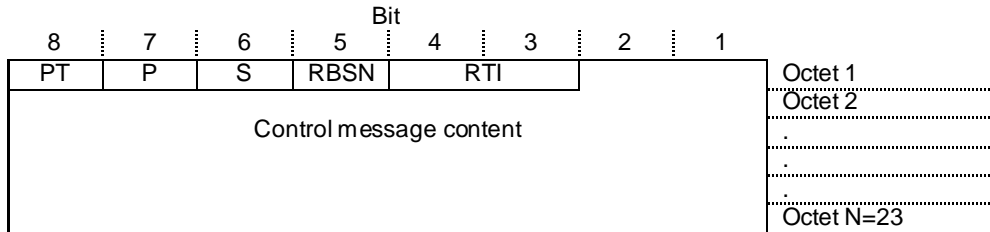

**Figure 8: Downlink RLC/MAC control block together with its MAC header**

#### 8.3.2.2 Uplink RLC/MAC control block format

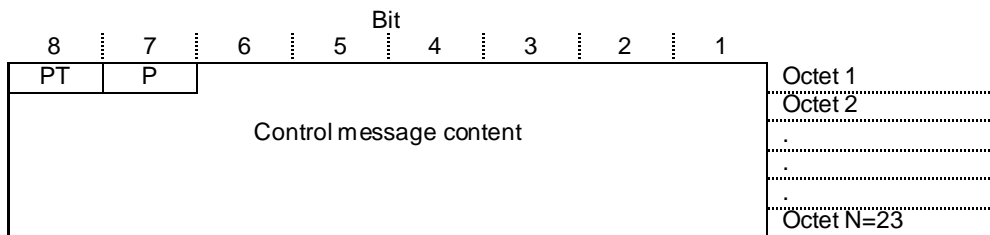
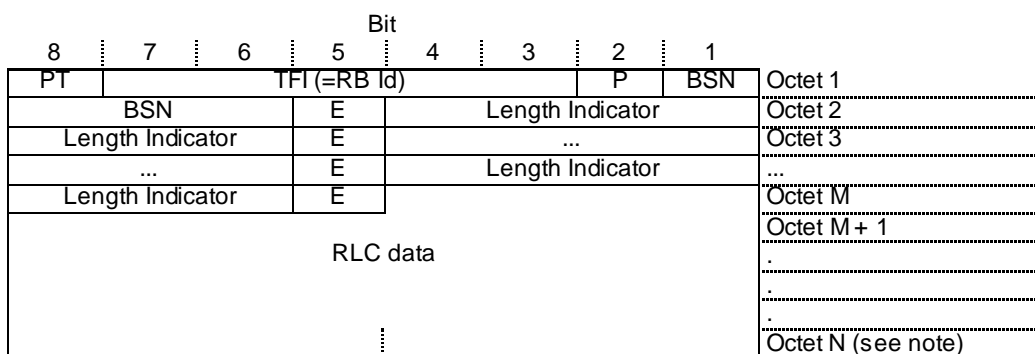

**Figure 9: Uplink RLC/MAC control block together with its MAC header**

### 8.3.3 RLC/MAC blocks for data transfer

#### 8.3.3.1 Downlink RLC/MAC block for data transfer

##### 8.3.3.1.1 RLC unacknowledged mode



NOTE: the RLC data may contain a non-integer number of octets.

**Figure 10: RLC/MAC block for data transfer in RLC unacknowledged mode**

8.3.3.1.2 RLC acknowledged mode

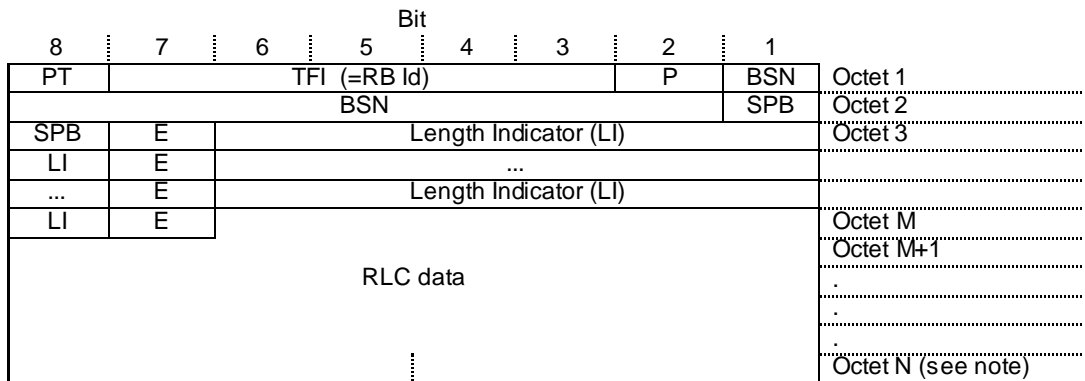

NOTE: the RLC data may contain a non-integer number of octets.

Figure 11: Downlink RLC/MAC block for data transfer in RLC acknowledged mode

8.3.3.1.3 RLC transparent mode

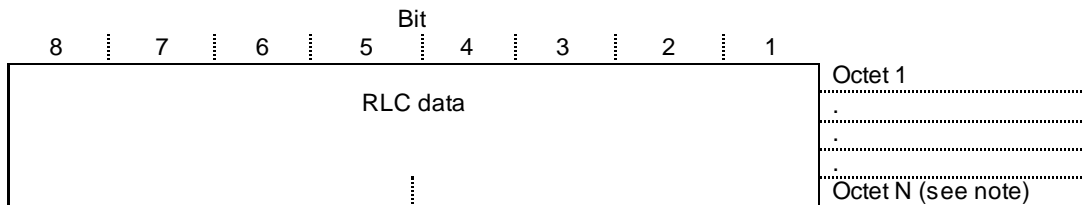

NOTE: the RLC data may contain a non-integer number of octets.  $N \geq 1$ .

Figure 12: Downlink RLC/MAC block for data transfer in RLC transparent mode

8.3.3.2 Uplink RLC/MAC block for data transfer

8.3.3.2.1 RLC unacknowledged mode

The uplink RLC/MAC block format for data transfer in RLC unacknowledged mode is the same as for downlink, as described in subclause 8.3.3.1.1.

8.3.3.2.2 RLC acknowledged mode

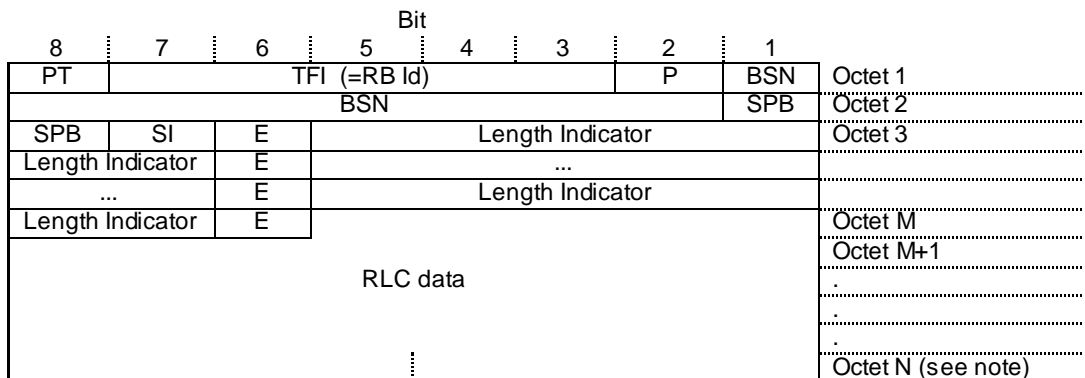

NOTE: the RLC data may contain a non-integer number of octets

Figure 13: Uplink RLC/MAC block for data transfer in RLC acknowledged mode

8.3.3.2.3 RLC transparent mode

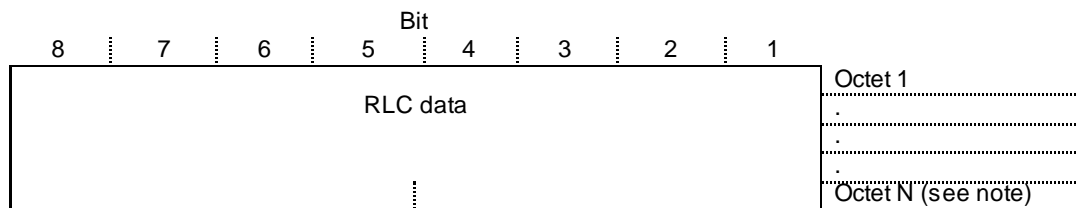

NOTE: the RLC data may contain a non-integer number of octets.  $N \geq 1$

Figure 14: Uplink RLC/MAC block for data transfer in RLC transparent mode

8.4 Ciphering in *lu mode*

8.4.1 General

Ciphering is provided following the same principles as when FLO is not used.

The ciphering function is performed either in the RLC sublayer or in the MAC sublayer according to the following rules:

- The RLC sublayer is responsible for ciphering/deciphering RLC data blocks in case of non-transparent RLC mode (unacknowledged or acknowledged);
- The MAC sublayer is responsible for ciphering/deciphering user data in case of transparent RLC mode. It is also responsible for ciphering/deciphering some RLC/MAC control messages as specified in 3GPP TS 44.160.

The ciphering function uses the ciphering algorithm f8 specified in 3GPP TS 35.201.

8.4.2 Parameters settings

8.4.2.1 RLC non-transparent mode

Table 2 defines how to set the input parameters to the ciphering algorithm.

Table 2: Input parameters to the ciphering algorithm

Input parameters	Size in bits		Settings		
			RLC Mode	Unack	Ack
Count	32	MSB	HFN	27 bits 0...134217727	23 bits 0...8388607
			RBid indicator	1 bit 1 (RBid available)	
	LSB	BSN	4 bits 0...15	8 bits 0...255	
Direction	1		Direction	1 bit 0 (uplink) 1 (downlink)	
Bearer	5		RBid	5 bits 0...31	
Length	11		Length in bits of the plain data to cipher	11 bits 0...1370	

NOTE: these parameters are the same as for DCCH and TCH TBF modes, except the maximum length, which is higher.

8.4.2.2 RLC transparent mode

3GPP TS 44.160 defines how to set the input parameters to the ciphering algorithm.

### 8.4.2.3 RLC/MAC control messages

3GPP TS 44.160 defines how to set the input parameters to the ciphering algorithm.

## 8.5 TFC Selection

### 8.5.1 TFC selection in the uplink

The selection of the TFC to be used in the uplink during each TTI is under the control of the MAC Layer in the MS. The MS should select a TFC according not only to the data available to be sent and the priority of the flows to which the data belongs, but also to the conditions of the radio channel. The conditions of the radio channel in the uplink are known only to the network, so the network should provide information to the MS to assist in the decision.

The algorithm for the selection of the TFC to be used in the uplink is as follows:

1. When defining the TFCS, the TFCs are ranked according to the radio conditions or signal quality required to achieved a specified quality of service (e.g. the higher the TFCI, the better the quality of the radio link required); this could be characterised, for example, in terms of RXLEV, BEP, the BLER on the different transport channels, or other parameters.
2. The ranking is communicated to the MS at call set-up by means of the order in which they are signalled in the assignment message: the TFCs are signalled in the assignment message in increasing order of quality of the link required.
3. Based on the measurement performed by the BSS, the network determines periodically within a call the “highest TFC” that, with the current radio conditions, would meet the quality of service criteria.
4. The network signals the “highest TFC” to the MS by transmitting in the downlink the value of the TFCI (within the TFCS defined for the uplink) corresponding to the highest TFC that the MS is allowed to select in the uplink. The network sends this TFCI, encoded as defined in subclause 7.5, using the inband signalling bits of a downlink radio packet (see subclause 7.4a). One coded TFCI is transmitted in every radio packet. In case of multislot operation, as the TFCS could be different on different timeslots, the “highest TFC” needs to be signalled separately for each timeslot.
5. The MS is allowed to use only TFCs whose TFCI is lower than or equal to the TFCI indicated by the network and that have not been restricted by higher layer signalling (see sub-clause 9.3). The set of these TFCs is called “valid TFCs”. The MS selects the particular TFC to be used for transmission in the uplink from the set of valid TFCs, according to the rules given below.

Every TTI, the MS selects the TFC within the set of valid TFCs using the following rules (see 3GPP TS 25.321):

1. No other TFC shall allow the transmission of more highest priority data than the chosen TFC.
2. No other TFC shall allow the transmission of more data from the next lower priority TBFs. Apply this criterion recursively for the remaining priority levels.

### 8.5.2 TFC selection in the downlink

The selection of the TFC to be used in the downlink during each TTI is under the control of the MAC Layer in the network. The network should select a TFC according not only to the data available to be sent and the priority of the flows to which the data belongs, but also to the conditions of the radio channel.

To determine the conditions of the radio channel on the downlink, the network may utilise the measurement report sent by the MS every 480ms, or if Enhanced Power Control (EPC) is supported, the measurement report sent by the MS every 120ms when in EPC mode.

## 8.6 Ciphering in *A/Gb mode*

Ciphering of FLO channels follows the same principles as when FLO is not used. When FLO is used in the PS domain, ciphering is provided for LLC PDUs and is performed by the SGSN following the same principles as ciphering in GPRS/EGPRS.



## 9 Layer 3 for FLO

### 9.1 In *lu mode*

The RRC layer is responsible for the setup, reconfiguration and release of the TrCH(s). The RRC procedures affected by the introduction of FLO are RB control procedures and RRC Connection Mobility procedures.

The following RRC messages are impacted by the introduction of FLO: RADIO BEARER SETUP, RADIO BEARER RECONFIGURATION, RADIO BEARER RELEASE and CELL UPDATE CONFIRM. New procedures to reconfigure only the transport channels are considered to be introduced in GERAN *lu mode*: Transport Channel Reconfiguration procedures. Additionally Radio Bearer Reconfiguration procedures could reconfigure either RB parameters or transport channels or physical parameters or all, if needed. If only TrCH(s) need to be reconfigured it is left whether Transport Channel Reconfiguration procedures could be introduced as a subset of the Reconfiguration procedures. Transport Channel Reconfiguration procedures cannot be used for modifying the physical parameters.

### 9.2 In A/Gb mode

Text will be added when FLO concepts for A/Gb mode have stabilized.

### 9.3 Transport and physical channel configuration

When setting up a new connection, Layer 3 indicates to the lower layers the following parameters to configure the physical layer, the MAC sublayer and the RLC sublayer:

- The transport channel identity (TrCH Id) and transport format set for each transport channel;
- The transport format combination set (TFCS) through CTFC (see subclause 9.4) together with the modulation parameter (GMSK and 8PSK, or 8PSK only);
- Semi-static parameters for the configuration of the basic physical subchannel (see Table 3): channel mode (FR or HR), modulation (GMSK and/or 8PSK), interleaving (20ms rectangular, 40ms diagonal or 60ms diagonal) and number of TrCHs.

To configure the transport format set, Layer 3 provides to the lower layers the following parameters for each transport channel:

- The semi-static attributes (see Table 4): CRC size (0, 6, 12, or 18 bits) and the rate matching attribute (1 to 256). Semi-static attributes are common to all transport formats for one transport channel;
- For each transport format, the dynamic attributes (see Table 5): TB size (1 to 1370 bits).

In order to address inactive transport channels in TFC(s), the first transport format of every TrCH is configured by default with the empty transport format. These default transport formats need not be signalled.

Each Layer 3 message that can set up or reconfigure TrCH(s) has to provide the mentioned information to the lower layers. When releasing a TrCH, only the TrCH Ids are signalled.

**Table 3: Basic physical subchannel parameters indicated by Layer 3**

Parameter	Range/Value	Comments
Mode	FR or HR	Two channel modes
Modulation	GMSK and/or 8PSK	Two modulation types
Interleaving	20ms rectangular 40ms diagonal 60ms diagonal	60ms interleaving for 8PSK channels only

**Table 4: Semi-static attributes indicated by Layer 3 for each TrCH**

Parameter	Range/Value	Comments
CRC size	0,6, 12 or 18	Four CRC sizes
Rate matching attribute	1...256	Same range as in UTRAN

**Table 5: Dynamic attributes indicated by Layer 3 for each TF**

Parameter	Range/Value	Comments
TB size	1...1370	Maximum obtained with 8PSK FR channel

The transport channels and the transport format combination set may be configured independently in the uplink and the downlink. Also, if the MS is configured to use multiple timeslots, the transport channels and the transport format combination set may be configured independently for each timeslot.

In the transport format combination set, it shall be specified whether each transport format combination can be used with both GMSK and 8PSK modulations or with 8PSK modulation only. The modulation parameter is signalled in the layer 3 message with the CTFC for each TFC. Only transport format combinations that are allowed for the modulation configured for the DBPSCH may be active within the TFCS. At handover certain TFCs may be automatically restricted (implicitly), or they may be reconfigured by the network.

When configuring or reconfiguring the TFCS, Layer 3 can optionally include transport format combination subset information to restrict the transport format combinations within the TFCS that can be used. This information could be in the form of a “minimum allowed transport format combination index”, an “allowed transport format combination list”, a “non-allowed transport format combination list” or other to be defined.

When reconfiguring the transport channels or the TFCS, an incremental reconfiguration will be possible, i.e. it will be possible to signal only the parameters of the transport channels or the TFCs that are added, modified or deleted. After the reconfiguration, the configuration is still consistent. For example, when releasing a transport channel, all the TFCs that use that transport channel shall also be removed from the TFCS.

If the size of the TFCI needs to be changed when reconfiguring the TFCS of a DBPSCH, that DBPSCH shall be ordered to a new DBPSCH. A new DBPSCH is a DBPSCH, which is not currently allocated to the MS.

When releasing a connection, no specific FLO information is signalled by Layer 3.

## 9.4 Calculated Transport Format Combination

### 9.4.1 Definition

The CTFCs are used to signal the transport format combination set. Every possible transport format combination is uniquely identified by one CTFC, including transport format combinations, which are not members of the transport format combination set.

Two formulas are used to define the CTFC (see 3GPP TS 25.331). Let  $I$  be the number of transport channels that are included in the transport format combination. Each transport channel  $\text{TrCH}_i$ ,  $i = 1, 2, \dots, I$ , has  $L_i$  transport formats, i.e. the transport format indicator  $TFIN_i$  can take  $L_i$  values,  $TFIN_i \in \{0, 1, 2, \dots, L_i - 1\}$ . For each transport channel, the transport format such that  $TFIN_i = 0$  is the empty transport format.

Define  $P_i = \prod_{j=0}^{i-1} L_j$ , where  $i = 1, 2, \dots, I$ , and  $L_0 = 1$

Let  $TFC(TFIN_1, TFIN_2, \dots, TFIN_I)$  be the transport format combination for which  $\text{TrCH}_1$  has transport format  $TFIN_1$ ,  $\text{TrCH}_2$  has transport format  $TFIN_2$ , etc. The corresponding  $CTFC(TFIN_1, TFIN_2, \dots, TFIN_I)$  is then computed as:

$$CTFC(TFIN_1, TFIN_2, \dots, TFIN_I) = \sum_{i=1}^I TFIN_i \cdot P_i$$

The transport format combination such that  $CTFC = 0$  is the empty transport format combination.

After computing the CTFC value for all allowed transport format combinations (a CTFC is defined for all transport format combinations, but it is only necessary to compute the CTFC for the allowed transport format combinations), the CTFCs are signalled in order. The TFCIs are then assigned in the same order, i.e. the first TFC signalled by its CTFC will correspond to TFCI = 0, the next corresponds to TFCI = 1, etc.

In a Layer 3 signalling message, the CTFC values are encoded using a variable size field, the size of which is the same for all values and depends on the highest value to be signalled. The possible sizes are: 2 bits, 4 bits, 6 bits, 8 bits, 12 bits and 16 bits. The size of the fields is signalled in the Layer 3 message.

## 9.4.2 Example

In this section, CTFC is elaborated by an example: circuit switched AMR over FLO. For the support of AMR, three transport channels need to be configured:

- TrCH<sub>1</sub> for class A bits and inband bits;
- TrCH<sub>2</sub> for class B bits;
- TrCH<sub>3</sub> for signalling.

Figure 15 below depicts the proposed TFCS for this AMR example.

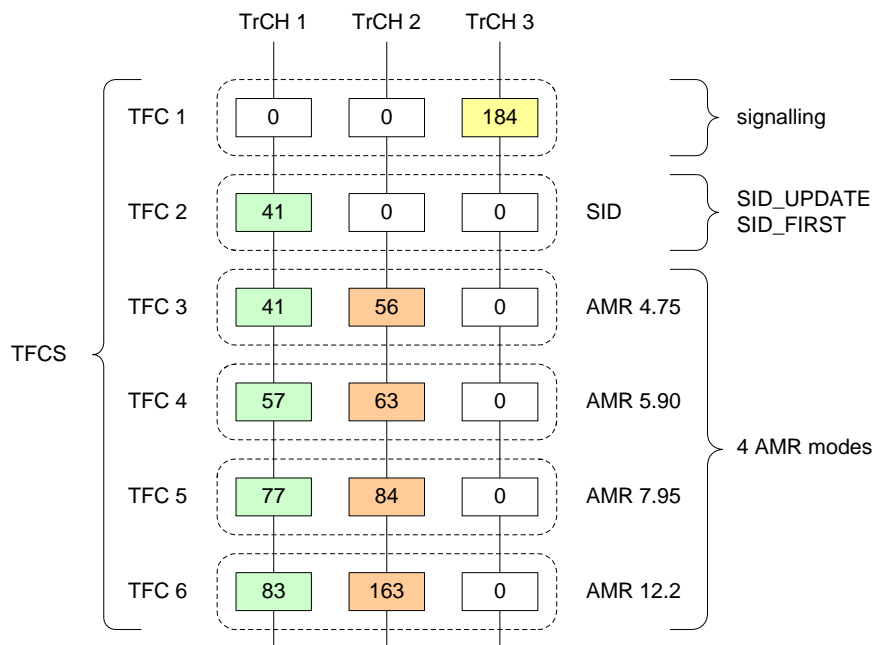

**Figure 15: TFCS Example.**

Six TFCs are configured. The first TFC is used for signalling where 184 bits are sent on TrCH<sub>3</sub> only. Then the active codec set contains 4 AMR modes (12.2 kbit/s, 7.95 kbit/s, 5.90 kbit/s and 4.75 kbit/s) requiring 4 different TFCs. Additionally one TFC is needed for SID\_UPDATE and SID\_FIRST where 41 bits are sent on TrCH<sub>1</sub> only. For each transport channel, the number of transport format(s) required is therefore:

- 5 transport formats for TrCH<sub>1</sub> (0, 41, 57, 77, 83);  $L_1 = 5$
- 5 transport formats for TrCH<sub>2</sub> (0, 56, 63, 84, 163);  $L_2 = 5$
- 2 transport formats for TrCH<sub>3</sub> (0, 184);  $L_3 = 2$

The  $P_i$  values can then be calculated for each transport format:

- $P_1 = L_0 = 1$ ;
- $P_2 = L_0 \times L_1 = 1 \times 5 = 5$ ;

$$- P_3 = L_0 \times L_1 \times L_2 = 1 \times 5 \times 5 = 25.$$

And for the CTFCs the values are:

- $CTFC(0, 0, 1) = (0 \times 1) + (0 \times 5) + (1 \times 25) = 25.$  -- TFC<sub>1</sub> for Signalling
- $CTFC(1, 0, 0) = (1 \times 1) + (0 \times 5) + (0 \times 25) = 1;$  -- TFC<sub>2</sub> for SID\_UPDATE and SID\_FIRST
- $CTFC(1, 1, 0) = (1 \times 1) + (1 \times 5) + (0 \times 25) = 6;$  -- TFC<sub>3</sub> for AMR 4.75 kbit/s
- $CTFC(2, 2, 0) = (2 \times 1) + (2 \times 5) + (0 \times 25) = 12;$  -- TFC<sub>4</sub> for AMR 5.90 kbit/s
- $CTFC(3, 3, 0) = (3 \times 1) + (3 \times 5) + (0 \times 25) = 18;$  -- TFC<sub>5</sub> for AMR 7.95 kbit/s
- $CTFC(4, 4, 0) = (4 \times 1) + (4 \times 5) + (0 \times 25) = 24;$  -- TFC<sub>6</sub> for AMR 12.2 kbit/s

## 9.5 TFC for Signalling

Reliable transport of signalling messages (control plane messages and RLC/MAC control messages) must be available throughout the radio access network and even in adverse channel conditions. That is the reason why the protection of signalling has been traditionally strong in GSM: CS1 coding has been used always for consistent performance in every cell, in every network (see 3GPP TS 45.003). With the flexibility offered by FLO, arises the possibility of changing the protection for signalling. It also becomes possible to multiplex signalling with other radio bearers. While this kind of flexibility is desired for the user plane, it should be avoided for the control plane as it might lead to inconsistent performance throughout the network (e.g. handover commands not available in some areas). For consistent performance, the configuration of the signalling shall be fixed. The first TFC, for which the TFCI=0, shall be used for sending signalling messages and in that TFC only the transport channel carrying the transport blocks of the signalling is active with the following transport format:

- 184 bits transport blocks;
- 18 bits CRC;
- 256 for the RMA.

NOTE: the value of the RMA does not matter since there is only one active TrCH.

This is depicted for instance on Figure 15 where TFC number 1 is reserved for the transport channel carrying signalling.

## 9.6 TBF configuration

When setting up a new TBF or reconfiguring an existing TBF, Layer 3 provides the following parameters to configure the MAC sublayer:

- for each TBF, the transport channel(s) and associated transport format set on to which the TBF is mapped (by means of the TrCH Id).

NOTE: As all the TBFs are mapped also to the transport channel used for signalling information, this does not need to be signalled.

---

# 10 Testing of FLO

Since FLO has several degrees of freedom when configuring transport channels, a complete test of every single possible configuration is not feasible. However similarly as in GSM/EDGE, testing of the implementation can be done through validation of performance requirements, as implementation errors directly translate into loss in terms of performance. That is, for instance an incorrect implementation of interleaving would mean poor performance. Testing of FLO shall therefore be done using a set of predefined radio bearers in conjunction with performance requirements. A correct implementation of FLO will fulfil the performance requirements of the predefined radio bearers. In other words, when performance requirements of the predefined radio bearers are met, it validates the implementation of FLO and ensures that it can support any possible configuration that fits within the limitations of section 6.4.

---

# 11 Impact on Specifications

The affected specifications by the introduction of FLO are:

- 3GPP TS 43.051: “GSM/EDGE Radio Access Network (GERAN) overall description; Stage 2”.
- 3GPP TS 44.004: “Layer 1 - General Requirements”.
- 3GPP TS 44.018: “Radio Resource Control protocol”.
- 3GPP TS 44.118: “Radio Resource Control protocol, Iu mode”.
- 3GPP TS 44.060: “Radio Link Control/Medium Access Control protocol”.
- 3GPP TS 44.160: “Radio Link Control/Medium Access Control protocol, Iu mode”.
- 3GPP TS 45.001, “Physical Layer on the Radio Path (General Description)”.
- 3GPP TS 45.002: “Multiplexing and multiple access on the radio path”.
- 3GPP TS 45.003: “Channel coding”.
- 3GPP TS 45.005, “Radio transmission and reception”.
- 3GPP TS 45.008, “Radio subsystem link control”.
- 3GPP TS 51.010, “Mobile Station (MS) conformance specification”
- 3GPP TS 51.021, “GSM radio aspects base station system equipment specification”.

# Annex A (informative): Block Codes for the TFCI

### Table A.1: Coding 5/36

TFCI	Coded TFCI
0,0,0,0,0	1,1
0,0,0,0,1	1,1,1,1,0,1,0,1,0,1,0,1,0,1,0,1,0,1,0,1,0,1,0,1,0,1,0,1,0,1,0,1,0
0,0,0,1,0	1,1,1,0,1,0,1,0,1,1,0,0,1,1,0,1,0,0,1,1,0,0,1,1,0,0,1,1,0,0,1,1,0,0
0,0,0,1,1	1,1,1,0,0,0,0,1,1,0,0,1,1,1,1,0,0,1,1,0,0,1,1,0,0,1,1,0,0,1,1,0,0
0,0,1,0,0	1,1,0,1,1,0,0,0,1,1,1,1,0,1,0,0,0,1,1,1,1,0,0,0,0,1,1,1,0,0,0,1,1,1
0,0,1,0,1	1,1,0,1,0,0,1,0,0,1,0,1,1,1,1,0,1,0,0,1,0,1,1,0,1,0,0,1,0,1,0,1,0,0,1,0
0,0,1,1,0	1,1,0,0,1,1,0,0,0,0,1,1,1,1,1,0,0,0,1,1,1,1,0,0,0,0,1,1,1,0,0,0,1,1
0,0,1,1,1	1,1,0,0,0,1,1,0,1,0,0,1,0,1,0,1,1,0,1,0,0,1,0,1,1,0,1,0,0,1,1,0,1,0,0
0,1,0,0,0	1,0,1,1,1,0,0,0,0,0,0,1,0,1,1,1,1,1,1,1,1,1,1,1,1,1,0,0,0,0,0,0,0,0
0,1,0,0,1	1,0,1,1,0,0,1,0,1,0,1,0,1,0,0,0,1,0,1,0,1,0,0,1,0,1,0,1,0,1,0,1,0,1,0
0,1,0,1,0	1,0,1,0,1,1,0,0,1,1,0,0,0,0,0,1,1,0,0,1,0,0,0,1,1,0,0,1,1,1,0,0,1,1,0
0,1,0,1,1	1,0,1,0,0,1,1,0,0,1,1,0,1,0,1,0,0,1,1,0,0,0,1,0,0,1,1,0,0,0,1,1,0,0,1,1
0,1,1,0,0	1,0,0,1,1,1,1,1,0,0,0,0,0,0,0,0,0,1,1,1,0,0,0,0,1,1,1,1,1,1,1,0,0,0
0,1,1,0,1	1,0,0,1,0,1,0,1,1,0,1,0,1,0,1,0,1,0,1,0,0,1,0,0,1,0,0,1,0,0,1,0,1,1,0,1
0,1,1,1,0	1,0,0,0,1,0,1,1,1,1,0,0,1,0,1,1,0,0,0,0,1,0,1,1,0,0,0,0,1,0,0,1,1,1,1,0
0,1,1,1,1	1,0,0,0,0,0,0,1,0,1,1,0,0,0,0,1,1,0,1,0,0,0,0,1,1,0,1,0,0,1,0,0,1,0,1,1
1,0,0,0,0	0,1,1,1,1,0,0,0,0,0,0,0,0,1,1,1,1,1,1,1,1,0,0,0,0,0,0,0,0,0,1,1,1,1,1,1
1,0,0,0,1	0,1,1,1,0,0,1,0,1,0,1,0,1,0,1,0,1,0,1,0,0,1,0,1,0,1,0,1,0,1,0,1,0,1,0
1,0,0,1,0	0,1,1,0,1,1,0,0,1,1,0,0,1,1,0,0,1,1,0,0,1,0,0,1,1,0,0,1,1,0,0,1,1,0,0
1,0,0,1,1	0,1,1,0,0,1,1,0,0,1,1,0,0,1,1,0,0,1,1,0,0,0,0,1,1,0,0,1,1,1,0,0,1,1,0,0
1,0,1,0,0	0,1,0,1,1,1,1,1,0,0,0,0,1,1,0,0,0,0,1,1,1,0,1,1,1,1,0,0,0,0,0,0,1,1,1
1,0,1,0,1	0,1,0,1,0,1,0,1,1,0,1,0,0,1,1,0,1,0,0,1,1,0,1,0,0,1,0,0,1,0,1,1,0,0,1,0
1,0,1,1,0	0,1,0,0,1,0,1,1,1,1,0,0,0,1,1,1,0,0,0,0,1,1,1,0,0,0,1,1,1,1,0,1,1,0,0,0,1
1,0,1,1,1	0,1,0,0,0,0,0,1,0,1,1,0,1,1,0,1,1,0,1,0,0,0,1,0,0,1,0,1,1,0,1,1,0,1,0,0
1,1,0,0,0	0,0,1,1,1,1,1,1,1,1,1,1,1,1,1,0,0,1,1,1,1,1,1,1,0,0,0,0,0,0,0,0,0,0,0
1,1,0,0,1	0,0,1,1,0,1,0,1,0,1,0,1,0,1,1,0,0,1,0,1,0,1,0,1,1,0,1,0,1,1,0,1,0,1,0,1
1,1,0,1,0	0,0,1,0,1,0,1,1,0,0,1,1,1,0,0,0,1,1,1,0,0,0,1,1,1,1,0,0,1,1,0,0,1,1,0
1,1,0,1,1	0,0,1,0,0,0,0,1,1,0,0,1,0,0,1,0,0,1,1,0,0,1,0,1,1,0,0,1,1,0,0,1,1,0,1
1,1,1,0,0	0,0,0,1,1,0,0,0,1,1,1,1,1,0,0,0,0,0,1,1,1,1,1,1,1,0,0,0,1,1,1,1,0,0,0
1,1,1,0,1	0,0,0,1,0,0,1,0,0,1,0,1,0,0,1,0,1,0,0,1,0,1,0,1,0,1,0,1,1,0,1,0,1,1,0,1
1,1,1,1,0	0,0,0,0,1,1,0,0,0,0,1,1,0,0,1,1,0,0,0,0,1,1,0,0,1,1,1,1,0,0,0,1,1,1,0
1,1,1,1,1	0,0,0,0,0,1,1,0,1,0,0,1,1,0,0,1,1,0,0,1,1,0,0,1,1,0,0,1,1,1,0,0,1,0,1,1

### Table A.2: Coding 4/28

TFCI	Coded TFCI
0,0,0,0	1,1
0,0,0,1	1,1,1,1,1,0,1,0,0,1,0,0,0,0,0,1,1,1,1,1,1,0,0,0,0,0,0
0,0,1,0	1,1,1,0,0,1,0,1,0,0,1,1,0,0,0,1,1,1,0,0,0,0,1,1,1,1,0,0
0,0,1,1	1,1,1,0,0,0,0,0,1,0,0,0,1,1,1,1,1,1,0,0,0,0,0,0,0,0,1,1
0,1,0,0	1,0,0,1,1,1,0,1,1,0,0,0,1,0,0,1,0,0,1,1,0,0,1,1,0,0,1,1
0,1,0,1	1,0,0,1,0,0,1,1,0,0,1,0,0,1,1,1,0,0,1,1,0,0,0,0,1,1,0,0
0,1,1,0	1,0,0,0,1,0,0,0,1,1,1,1,0,1,0,1,0,0,0,0,1,1,1,1,0,0,0,0
0,1,1,1	1,0,0,0,0,1,1,0,0,1,0,1,1,0,1,1,0,0,0,0,1,1,0,0,1,1,1,1
1,0,0,0	0,1,0,1,1,1,0,0,0,0,0,1,0,1,1,0,1,0,1,0,1,0,1,0,1,0,1,0,1,0
1,0,0,1	0,1,0,1,0,0,1,0,1,0,1,1,1,1,0,0,0,1,0,1,0,1,0,1,0,0,1,0,1,0,1
1,0,1,0	0,1,0,0,1,0,0,1,0,1,1,0,1,0,1,0,1,0,1,0,0,1,0,1,1,0,1,0,0,1
1,0,1,1	0,1,0,0,0,1,1,1,1,0,0,0,1,0,0,1,0,0,1,0,0,1,0,1,0,1,0,1,1,0
1,1,0,0	0,0,1,1,0,1,0,0,1,1,1,0,0,0,1,0,0,1,1,0,0,1,1,0,0,1,1,0,0,1,1,0
1,1,0,1	0,0,1,1,0,0,0,1,0,1,0,1,1,1,0,0,0,1,1,0,0,1,0,0,1,0,1,1,0,0,1
1,1,1,0	0,0,1,0,1,1,1,0,0,0,1,0,1,1,0,0,0,1,0,1,1,0,1,0,0,1,0,0,1,0,1
1,1,1,1	0,0,1,0,1,0,1,1,1,0,0,1,0,0,1,0,0,1,0,1,1,0,0,1,1,0,0,1,1,0,1,0

**Table A.3: Coding 3/24**

<b>TFCI</b>	<b>Coded TFCI</b>
0,0,0	1,1
0,0,1	1,1,1,0,0,0,0,1,1,1,0,0,0,0,1,1,1,0,0,0,0,1,1,1,0,0,0,0,1,1,1,1
0,1,0	1,0,0,1,1,0,0,1,0,0,1,0,0,1,1,0,0,1,0,0,1,0,0,1,1,0,0,1,0,0,1,0,0
0,1,1	1,0,0,0,0,1,1,1,0,0,0,0,1,1,1,0,0,0,0,1,1,1,0,0,0,0,1,1,1,0,0,1,0,0
1,0,0	0,1,0,1,0,1,0,0,1,0,1,0,1,0,1,0,0,1,0,1,0,1,0,1,0,0,1,0,0,1,0,1,0
1,0,1	0,1,0,0,1,0,1,0,1,0,0,1,0,1,0,0,1,0,1,0,0,1,0,1,0,1,0,1,0,1,0,1,0
1,1,0	0,0,1,1,0,0,1,0,0,1,1,0,0,1,0,0,1,1,0,0,1,0,0,1,1,0,0,1,0,0,1,0,0,1
1,1,1	0,0,1,0,1,1,0,0,0,1,0,1,1,0,0,0,1,0,1,1,0,0,0,1,0,1,1,0,0,0,1,0,0,1

**Table A.4: Coding 2/16**

<b>TFCI</b>	<b>Coded TFCI</b>
0,0	1,1,1,1,1,1,1,1,1,1,1,1,1,1,1,1,1,1
0,1	1,0,0,1,0,0,1,0,0,1,0,0,1,0,0,1,0,0,1
1,0	0,1,0,0,1,0,0,1,0,0,1,0,0,1,0,0,1,0,0
1,1	0,0,1,0,0,1,0,0,1,0,0,1,0,0,1,0,0,1,0

**Table A.5: Coding 1/8**

<b>TFCI</b>	<b>Coded TFCI</b>
0	1,1,1,1,1,1,1,1
1	0,0,0,0,0,0,0,0

## Annex B (informative): Header fields

### B.1 Payload Type (PT) field

The Payload Type (PT) field indicates the type of data contained in the remainder of the RLC/MAC block. It is encoded as shown below.

**Table B.1: Payload Type (PT) field**

Bit	PT: Payload Type
0	RLC Data Block
1	RLC/MAC Control block

### B.2 Polling (P) bit

The Polling (P) bit indicates whether or not the transmitter is polling for acknowledgement. When included in an RLC/MAC block for data transfer, it also allows the reporting of link quality measurements. It is encoded as shown below.

**Table B.2: Polling (P) bit**

Bit	P: Polling bit
0	No polling
1	Polling required

### B.3 Segmentation (S) bit

The segmentation (S) bit indicates whether or not the RLC/MAC control block is a segment of an RLC/MAC control message. It is encoded as shown below.

**Table B.3: Segmentation (S) bit**

Bit	S: Segmentation bit
0	The RLC/MAC control block contains an entire RLC/MAC control message
1	The RLC/MAC control block contains a segment of an RLC/MAC control message

### B.4 Reduced Block Sequence Number (RBSN) bit

The Reduced Block Sequence Number (RBSN) bit carries the sequence number of the RLC/MAC control blocks. The RBSN bit is encoded as a binary number with range 0 to 1. The RBSN bit is included if and only if the S bit is set.

### B.5 Radio Transaction Identifier (RTI) field

The Radio Transaction Identifier (RTI) field is used to group the RLC/MAC control blocks that make up an RLC/MAC control message and identifies the segmented control message sequence with which the RLC/MAC control block is associated. The RTI field is 2 bits in length with range 0 to 3. The RTI field is present if and only if the S bit is set.



## B.6 Temporary Flow Identity (TFI) field

The Temporary Flow Identity (TFI) field identifies the Temporary Block Flow (TBF) to which the RLC data block belongs. It is 5 bits in length and encoded as a binary number with range 0 to 31. The TFI shall equal the Radio Bearer identity (RB Id) of the radio bearer to which the RLC data block belongs.

## B.7 Block Sequence Number (BSN) field

### B.7.1 General

The Block Sequence Number (BSN) field carries the sequence absolute Block Sequence Number (BSN') modulo Sequence Number Space (SNS) of each RLC data block within the TBF.

### B.7.2 RLC unacknowledged mode

The BSN size is 4 bits, covering a SNS of 16.

### B.7.3 RLC acknowledged mode

The BSN size is 8 bits, covering a SNS of 256.

## B.8 Split Block Indicator (SPB) field

The Split Block indicator (SPB) field is used to indicate whether a data block that is retransmitted has been resegmented (e.g. due to switch from 8-PSK to GMSK modulation). It allows for splitting RLC data over two radio blocks. Whether it is needed to consider finer segmentation is FFS. It is encoded as shown below.

**Table B.4: Split Block Indicator (SPB) field**

Bit	SPB: Split Block Indicator field
0 0	No retransmission
0 1	Reserved
1 0	Retransmission (first part of the block)
1 1	Retransmission (second part of the block)

## B.9 Stall Indicator (SI) field

The Stall Indicator (SI) field indicates whether the mobile station's RLC transmit window is stalled or not. It is encoded as shown below.

**Table B.5: Stall Indicator (SI) field**

Bit	SI: Stall Indicator field
0	MS RLC Transmit window is not stalled
1	MS RLC Transmit window is stalled

## B.10 Extension (E) bit

The Extension (E) bit indicates the presence of an optional octet in the RLC data block header. It is encoded as shown below.

**Table B.6: Extension (E) bit**

Bit	E: Extension bit
0	Extension octet follows immediately
1	No extension octet follows

## B.11 Length Indicator (LI) field

The Length Indicator is used to delimit upper layer PDUs within the RLC data block. It is defined as the LI field in EGPRS TBF mode.

## Annex C: Change history

Change history								
Date	TSG GERAN#	TSG Doc.	CR	Rev	Subject/Comment	Old	New	
2003-04	14	GP-031048			Approved for Release 6		6.0.0	
2003-06	15	GP-031652	001	1	TFC selection in the uplink	6.0.0	6.1.0	
2003-06	15	GP-031653	002	1	Miscellaneous Clarifications and Corrections	6.0.0	6.1.0	
2003-06	15	GP-031542	004		Ciphering and placeholders for Gb mode	6.0.0	6.1.0	
2003-06	15	GP-031552	005		Miscellaneous corrections	6.0.0	6.1.0	
2003-08	16	GP-032235	006	2	Modulation parameter for TFCs	6.1.0	6.2.0	
2003-08	16	GP-032017	009		Bit Swapping for the TFCI	6.1.0	6.2.0	
2003-11	17	GP-032701	010	2	Architecture and signalling principles for FLO	6.2.0	6.3.0	
2003-11	17	GP-032370	012		Removal of informative Annex on two-stage interleaving	6.2.0	6.3.0	
2003-11	17	GP-032472	015		Signalling on half rate channels	6.2.0	6.3.0	
2003-11	17	GP-032796	016		Block Code sequences for 5 bit TFCI	6.2.0	6.3.0	
2004-02	18	GP-040234	013	1	TFCS Reconfiguration in FLO	6.3.0	6.4.0	
2004-02	18	GP-040163	017		Correction on signalling for half rate channels	6.3.0	6.4.0	
2004-04	19	GP-041166	019	1	One TFC for signalling on HR channels	6.4.0	6.5.0	
2004-06	20	GP-041701	018	3	Signalling for Uplink TFC selection	6.5.0	6.6.0	
2004-06	20	GP-041411	020		Correction to dynamic attributes of transport format – Retransmission number	6.5.0	6.6.0	
2004-11	22	GP-042625	023		TFC selection in the downlink	6.6.0	6.7.0	
2005-01	23	GP-050484	024	1	Inclusion of 60ms interleaving for FLO	6.7.0	6.8.0	
2007-08	35				Version for Release 7	6.8.0	7.0.0	
2008-12	40				Version for Release 8	7.0.0	8.0.0	
2009-12	44				Version for Release 9	8.0.0	9.0.0	
2011-03	49				Version for Release 10	9.0.0	10.0.0	
2012-09	55				Version for Release 11	10.0.0	11.0.0	