

3GPP TS 45.008 V11.5.0 (2013-08)

Technical Specification

**3rd Generation Partnership Project;
Technical Specification Group GSM/EDGE Radio Access
Network;
Radio subsystem link control
(Release 11)**



The present document has been developed within the 3rd Generation Partnership Project (3GPP™) and may be further elaborated for the purposes of 3GPP.

The present document has not been subject to any approval process by the 3GPP Organisational Partners and shall not be implemented. This Specification is provided for future development work within 3GPP only. The Organisational Partners accept no liability for any use of this Specification. Specifications and reports for implementation of the 3GPP™ system should be obtained via the 3GPP Organisational Partners' Publications Offices.

Keywords

GSM, radio

3GPP

Postal address

3GPP support office address

650 Route des Lucioles - Sophia Antipolis
Valbonne - FRANCE
Tel.: +33 4 92 94 42 00 Fax: +33 4 93 65 47
16

Internet

<http://www.3gpp.org>

Copyright Notification

No part may be reproduced except as authorized by written permission.
The copyright and the foregoing restriction extend to reproduction in all media.

© 2013, 3GPP Organizational Partners (ARIB, ATIS, CCSA, ETSI, TTA, TTC).
All rights reserved.

UMTS™ is a Trade Mark of ETSI registered for the benefit of its members
3GPP™ is a Trade Mark of ETSI registered for the benefit of its Members and of the 3GPP Organizational Partners
LTE™ is a Trade Mark of ETSI currently being registered for the benefit of its Members and of the 3GPP Organizational Partners
GSM® and the GSM logo are registered and owned by the GSM Association

Contents

Foreword.....	7
1 Scope.....	8
1.1 References	8
1.2 Abbreviations.....	10
1.3 Definitions	10
1.4 Restrictions	10
2 General.....	10
3 Handover	12
3.1 Overall process	12
3.2 MS measurement procedure.....	12
3.3 BSS measurement procedure	12
3.4 Strategy.....	12
4 RF power control.....	13
4.1 Overall process	13
4.2 MS implementation.....	13
4.3 MS power control range.....	14
4.4 BSS implementation	15
4.4.1 VAMOS subchannel power control for BSS in down link.....	15
4.5 BSS power control range	15
4.6 Strategy	15
4.7 Timing	16
4.7.1 Normal Power Control	16
4.7.2 Fast Power Control	16
4.7.3 Enhanced Power Control	16
4.8 Dedicated channels used for a voice group call or voice broadcast	17
5 Radio link failure	17
5.1 Criterion.....	17
5.2 MS procedure.....	17
5.3 BSS procedure	18
6 Idle mode tasks.....	18
6.1 Introduction.....	18
6.2 Measurements for normal cell selection.....	19
6.3 Measurements for stored list cell selection	19
6.4 Criteria for cell selection and reselection.....	20
6.5 Downlink signalling failure.....	21
6.6 Measurements for Cell Reselection	22
6.6.1 Monitoring of received signal level and BCCH data.....	22
6.6.2 Path loss criteria and timings for cell re-selection	23
6.6.3 Cell reselection algorithm for SoLSA	24
6.6.4 Measurements on cells of other radio access technologies.....	24
6.6.5 Algorithm for cell re-selection from GSM to UTRAN based on cell ranking	29
6.6.6 Algorithm for inter-RAT cell re-selection based on priority information	30
6.6.7 Cell selection and re-selection to CSG cells and hybrid cells	32
6.6.7.1 Cell re-selection to CSG cells	32
6.6.7.1a Cell re-selection to hybrid cells	34
6.6.7.2 Manual CSG ID selection	34
6.7 Release of TCH, SDCCH and DBPSCH	34
6.7.1 Normal case	34
6.7.2 Call re-establishment	35
6.8 Abnormal cases and emergency calls	35
7 Network pre-requisites	36
7.1 BCCH carriers	36
7.2 Identification of surrounding BSS for handover measurements	37

7.3	Handover measurements on other radio access technologies.....	38
7.4	Handover measurements on UTRAN CSG cells and hybrid cells	42
8	Radio link measurements.....	42
8.1	Signal level	42
8.1.1	General.....	42
8.1.2	Physical parameter.....	43
8.1.3	Statistical parameters	44
8.1.4	Range of parameter.....	44
8.1.5	Measurement quantity for other radio access technologies	44
8.1.5.1	UTRAN FDD.....	44
8.1.5.2	UTRAN TDD.....	45
8.1.5.3	cdma2000.....	45
8.1.5.4	E-UTRAN FDD.....	45
8.1.5.5	E-UTRAN TDD.....	46
8.2	Signal quality	46
8.2.1	General.....	46
8.2.2	Physical parameter.....	46
8.2.3	Statistical parameters	47
8.2.3.1	RXQUAL.....	47
8.2.3.2	MEAN_ BEP and CV_ BEP.....	47
8.2.4	Range of parameter RXQUAL.....	48
8.2.5	Range of parameters MEAN_ BEP and CV_ BEP	50
8.3	Aspects of discontinuous transmission (DTX)	53
8.4	Measurement reporting	54
8.4.1	Measurement reporting for the MS	54
8.4.1a	Measurement reporting for the MS in FPC mode	55
8.4.1b	Measurement reporting for the MS in EPC mode.....	55
8.4.2	Measurement reporting for the MS on a SDCCH	56
8.4.3	Additional cell reporting requirements for multi band MS	57
8.4.4	Common aspects for the MS on a TCH, a SDCCH or a DBPSCH.....	57
8.4.5	Measurement reporting for the BSS	58
8.4.6	Extended measurement reporting.....	58
8.4.7	Additional cell reporting requirements for multi-RAT MS.....	59
8.4.8	Enhanced Measurement Reporting	60
8.4.8.1	Reporting Priority	60
8.4.8.2	Measurement Reporting	61
8.4.8.3	NBR_RCVD_BLOCKS for FLO	62
8.4.9	Requirements for measurement and reporting of CSG cells and hybrid cells	63
8.5	Absolute MS-BTS distance	63
8.5.1	General.....	63
8.5.2	Physical parameter.....	63
9	Control parameters.....	64
10	GPRS mode tasks	72
10.1	Cell Re-selection	72
10.1.1	Monitoring the received signal level and PBCCH data	73
10.1.1.1	Packet idle mode or MAC-Idle state.....	73
10.1.1.2	Packet transfer mode or MAC-Shared state.....	74
10.1.1.2a	Broadcast/multicast receive mode	75
10.1.1.3	Monitoring cells of other radio access technologies	75
10.1.2	Cell Re-selection Criteria	80
10.1.3	Cell Re-selection Algorithm	81
10.1.3.1	Abnormal cell reselection	82
10.1.3.2	Algorithm for cell re-selection from GSM to UTRAN based on cell ranking.....	83
10.1.3.3	Algorithm for inter-RAT cell re-selection based on priority information	84
10.1.3.4	Cell selection and re-selection to CSG cells and hybrid cells.....	84
10.1.4	Network controlled Cell re-selection.....	84
10.1.4.1	Measurement reporting.....	85
10.1.4.2	Cell re-selection command	90
10.1.4.3	Exceptional cases.....	90
10.1a	Measurement and Reporting of CSG Cells and hybrid cells	90

10.2	RF Power Control	91
10.2.1	MS output power.....	91
10.2.2	BTS output power.....	92
10.2.3	Measurements at MS side.....	93
10.2.3.1	Deriving the C value	94
10.2.3.1.1	Packet idle mode or MAC-Idle state.....	94
10.2.3.1.2	Packet transfer mode or MAC-Shared state.....	94
10.2.3.2	Derivation of Channel Quality Report	96
10.2.3.2.1	Packet transfer mode or MAC-Shared state.....	96
10.2.3.2.2	Void	99
10.2.3.2.3	Measurement reporting.....	99
10.2.3.2.4	Measurement reporting - additional requirements for downlink dual carrier	100
10.2.3.3	Range of parameters MEAN_BEP and CV_BEP for EGPRS2	101
10.2.4	Measurements at BSS side	104
10.2a	Packet-switched Handover.....	104
10.3	Measurement requirements	104
10.4	Control parameters	104
11	CTS mode tasks.....	111
11.1	CTS idle mode tasks	111
11.1.1	CTS cell selection	111
11.1.1.1	Synchronization and measurements for CTS cell selection	111
11.1.1.2	Initial synchronization of CTS-MS	111
11.1.2	Criterion for CTS cell selection.....	112
11.1.3	Monitoring of CTSBCH and CTSPCH.....	112
11.1.3.1	Monitoring of received signal level.....	112
11.1.3.2	Downlink beacon failure	112
11.1.3.3	Downlink paging failure.....	112
11.1.4	Procedures with reporting to the CTS-FP.....	113
11.1.4.1	AFA monitoring.....	113
11.1.4.2	BCCH detection.....	113
11.1.4.3	Observed Frequency Offset (OFO) measurement	113
11.2	Intra-cell handover.....	114
11.2.1	Overall process	114
11.2.2	CTS-MS measurement procedure.....	114
11.2.3	CTS-FP measurement procedure	114
11.2.4	Strategy.....	114
11.3	RF power control.....	114
11.3.1	Overall process.....	114
11.3.2	CTS-MS implementation.....	114
11.3.3	CTS-MS power control range.....	115
11.3.4	CTS-FP implementation	115
11.3.5	CTS-FP power control range	115
11.3.6	Strategy.....	115
11.3.7	Timing.....	115
11.4	Radio link failure	116
11.4.1	Criterion.....	116
11.4.2	CTS-MS procedure.....	116
11.4.3	CTS-FP procedure	116
11.5	Radio link measurements.....	116
11.5.1	Signal strength.....	116
11.5.1.1	General	116
11.5.1.2	Physical parameter	117
11.5.1.3	Statistical parameters	117
11.5.1.4	Range of parameter	117
11.5.2	Signal quality	117
11.5.2.1	General	117
11.5.2.2	Physical parameter	117
11.5.2.3	Statistical parameters	117
11.5.2.4	Range of parameter	117
11.5.3	Aspects of discontinuous transmission (DTX)	117
11.5.4	Measurement reporting for the CTS-MS on a TCH	117
11.6	Control of CTS-FP service range	118

11.7	Control parameters	118
12	COMPACT Mode Tasks	120
12.1	Introduction.....	120
12.2	Network Pre-requisites	120
12.2.1	CPBCCCH carriers	120
12.3	COMPACT Idle Mode Tasks.....	120
12.3.1	Introduction.....	120
12.3.2	Measurements for COMPACT Cell Selection	121
12.3.3	Measurements for COMPACT Stored List Cell Selection	121
12.3.4	Criteria for COMPACT Cell Selection	121
12.3.5	Downlink Signalling Failure	122
12.4	COMPACT Cell Reselection	122
12.4.1	Monitoring the received signal level and CPBCCCH data	122
12.4.1.1	Packet idle mode or MAC-Idle state.....	122
12.4.1.2	Packet transfer mode or MAC-Shared state.....	123
12.4.2	COMPACT cell reselection criteria	124
12.4.3	COMPACT cell reselection algorithm	124
12.4.4	Network controlled Cell reselection	124
12.4.5	COMPACT cell reselection measurement opportunities	124
Annex A (informative):	Definition of a basic GSM or DCS 1 800 handover and RF power control algorithm.....	125
A.1	Scope.....	125
A.2	Functional requirement.....	125
A.3	BSS pre-processing and threshold comparisons	126
A.3.1	Measurement averaging process.....	126
A.3.2	Threshold comparison process.....	127
A.3.2.1	RF power control process	127
A.3.2.2	Handover Process	128
A.4	BSS decision algorithm	129
A.4.1	Internal intracell handover according to radio criteria: (Interference problems)	129
A.4.2	Internal handover according to other criteria	130
A.4.3	General considerations	130
A.5	Channel allocation	130
A.6	Handover decision algorithm in the MSC	131
Annex B (informative):	Power Control Procedures.....	133
B.1	Open loop control	133
B.2	Closed loop control.....	134
B.3	Quality based control.	134
B.4	BTS power control.....	135
B.5	Example.....	135
B.6	Interworking between normal and fast power control for ECSD	136
B.7	Interworking between normal and enhanced power control (EPC).....	137
Annex C (informative):	Example Interference Measurement Algorithm.....	139
Annex D (informative):	Example Selection of Modulation and Coding Schemes based on Link Quality Reports.....	140
Annex E (informative):	Change history	141

Foreword

This Technical Specification has been produced by the 3rd Generation Partnership Project (3GPP).

The contents of the present document are subject to continuing work within the TSG and may change following formal TSG approval. Should the TSG modify the contents of the present document, it will be re-released by the TSG with an identifying change of release date and an increase in version number as follows:

Version x.y.z

where:

x the first digit:

1 presented to TSG for information;

2 presented to TSG for approval;

3 or greater indicates TSG approved document under change control.

y the second digit is incremented for all changes of substance, i.e. technical enhancements, corrections, updates, etc.

z the third digit is incremented when editorial only changes have been incorporated in the document.

1 Scope

The present document specifies the Radio sub-system link control implemented in the Mobile Station (MS), Base Station System (BSS) and Mobile Switching Centre (MSC) of the digital cellular telecommunications systems GSM.

Unless otherwise specified, references to GSM also include operation in any band.

1.1 References

The following documents contain provisions which, through reference in this text, constitute provisions of the present document.

- References are either specific (identified by date of publication, edition number, version number, etc.) or non-specific.
- For a specific reference, subsequent revisions do not apply.
- For a non-specific reference, the latest version applies. In the case of a reference to a 3GPP document (including a GSM document), a non-specific reference implicitly refers to the latest version of that document *in the same Release as the present document*.

- [1] 3GPP TR 21.905: "Vocabulary for 3GPP Specifications".
- [2] 3GPP TS 23.003: "Numbering, addressing and identification".
- [3] 3GPP TS 23.009: "Handover procedures".
- [4] 3GPP TS 23.122: "NAS Functions related to Mobile Station (MS) in idle mode".
- [5] 3GPP TS 25.101: "UE Radio transmission and reception (FDD)".
- [6] 3GPP TS 25.123: "Requirements for support of Radio Resource Management (TDD)".
- [7] 3GPP TS 25.133: "Requirements for support of Radio Resource Management (FDD)".
- [8] 3GPP TS 25.304: "UE Procedures in Idle Mode and Procedures for Cell Reselection in Connected Mode".
- [9] 3GPP TS 25.331: "Radio Resource Control (RRC); Protocol Specification".
- [10] 3GPP TS 26.093: "AMR Speech Codec; Source Controlled Rate operation".
- [11] 3GPP TS 43.022: "Functions related to Mobile Station (MS) in idle mode and group receive mode".
- [12] 3GPP TS 43.064: "Overall description of the GPRS Radio Interface; Stage 2".
- [13] 3GPP TS 43.246: "Multimedia Broadcast Multicast Service (MBMS) in the GERAN; Stage 2".
- [14] 3GPP TS 43.068: "Voice Group Call Service (VGCS); Stage 2".
- [15] 3GPP TS 44.004: "Layer 1; General requirements".
- [16] 3GPP TS 44.006: "Mobile Station - Base Station System (MS - BSS) interface; Data Link (DL) layer specification".
- [17] 3GPP TS 44.018: "Mobile radio interface layer 3 specification; Radio Resource Control Protocol".
- [18] 3GPP TS 44.056: "GSM Cordless Telephony System (CTS), Phase 1; CTS radio interface layer 3 specification".

- [19] 3GPP TS 44.060: “General Packet Radio Service (GPRS); Mobile Station (MS) - Base Station System (BSS) interface; Radio Link Control (RLC) / Medium Access Control (MAC) protocol”.
- [20] 3GPP TS 44.118: “Mobile radio interface layer 3 specification, Radio Resource Control (RRC) Protocol, Iu Mode”.
- [21] 3GPP TS 44.160: “Mobile Station (MS) - Base Station System (BSS) interface; Radio Link Control/Medium Access Control (RLC/MAC) protocol; Iu mode”.
- [22] 3GPP TS 45.002: “Multiplexing and multiple access on the radio path”.
- [23] 3GPP TS 45.003: “Channel coding”
- [24] 3GPP TS 45.005: “Radio transmission and reception”.
- [25] 3GPP TS 45.010: “Radio subsystem synchronization”.
- [26] 3GPP TS 45.056: “CTS-FP radio subsystem”.
- [27] 3GPP TR 45.902: “Flexible Layer One”.
- [28] 3GPP TS 46.011: “Full rate speech; Substitution and muting of lost frames for full rate speech channels”.
- [29] 3GPP TS 46.012: “Full rate speech; Comfort noise aspect for full rate speech traffic channels”.
- [30] 3GPP TS 46.031: “Full rate speech; Discontinuous Transmission (DTX) for full rate speech traffic channels”.
- [31] 3GPP TS 48.008: “Mobile-services Switching Centre - Base Station System (MSC - BSS) interface, Layer 3 specification”.
- [32] 3GPP TS 48.058: “Base Station Controller - Base Transceiver Station (BSC - BTS) interface; Layer 3 specification”.
- [33] 3GPP TS 51.010: “Mobile Station (MS) conformity specification”.
- [34] 3GPP TS 51.011: “Specification of the Subscriber Identity Module - Mobile Equipment (SIM - ME) interface”.
- [35] TIA/EIA/IS-2000-5-A: “Upper Layer (Layer 3) Signaling Standard for cdma2000 Spread Spectrum Systems”.
- [36] TIA/EIA/IS-833: “Multi-Carrier Specification for Spread Spectrum Systems on GSM MAP (MC-MAP) (Lower Layers Air Interface)”.
- [37] 3GPP TS 36.101: “Evolved Universal Terrestrial Radio Access (E-UTRA); User Equipment (UE) radio transmission and reception”.
- [38] 3GPP TS 36.104: “Evolved Universal Terrestrial Radio Access (E-UTRA); Base Station (BS) radio transmission and reception”.
- [39] 3GPP TS 36.133: “Evolved Universal Terrestrial Radio Access (E-UTRA); Requirements for support of radio resource management”.
- [40] 3GPP TS 36.304: “Evolved Universal Terrestrial Radio Access (E-UTRA); User Equipment (UE) procedures in idle mode”.
- [41] 3GPP TS 36.331: “Evolved Universal Terrestrial Radio Access (E-UTRA); Radio Resource Control (RRC); Protocol Specification”.
- [42] 3GPP TS 31.102: “Characteristics of the Universal Subscriber Identity Module (USIM) application”.
- [43] 3GPP TS 24.301: “Non-Access-Stratum (NAS) protocol for Evolved Packet System (EPS); Stage 3”.

- [44] 3GPP TS 22.268: "Public Warning System (PWS) requirements; Stage 1".
- [45] 3GPP TS 23.251: "Network sharing; Architecture and functional description".
- [46] 3GPP TS 24.008: "Mobile Radio Interface Layer 3 specification; Core Network Protocols - Stage 3".

1.2 Abbreviations

Abbreviations used in the present document are listed in 3GPP TR 21.905.

1.3 Definitions

CSG Whitelist: A list provided by NAS containing all the CSG identities and their PLMN IDs of the CSGs to which the subscriber belongs, see 3GPP TS 23.122.

Note: This list is known as "Allowed CSG List" in Rel-8 specifications.

CSG cell: The definition of CSG cell for UTRAN is given in 3GPP TS 25.304; the definition of CSG cell for E-UTRAN is given in 3GPP TS 36.304.

Hybrid cell: The definition of hybrid cell for UTRAN is given in 3GPP TS 25.304; the definition of hybrid cell for E-UTRAN is given in 3GPP TS 36.304.

Network sharing: network sharing is an optional feature that allows different core network operators to connect to the same shared radio access network (see 3GPP TS 23.251). When network sharing is in use within a given cell, the network broadcasts within system information the PLMN identities of the PLMNs sharing the cell. A mobile station supporting network sharing uses this information for its PLMN (re)selection processes and indicates the selected PLMN to the BSS.

1.4 Restrictions

Independently of what is stated elsewhere in this and other 3GPP specifications, mobile station support for PBCCH and PCCCH is optional for A/Gb-mode of operation. The network shall never enable PBCCH and PCCCH.

2 General

The radio sub-system link control aspects that are addressed are as follows:

- Handover;
- RF Power control in *A/Gb mode*, including fast power control for E-TCH and enhanced power control for TCH and O-TCH;
- RF Power control in *Iu mode*, including fast power control for E-TCH and enhanced power control for DBPSCH (in MAC-Dedicated and MAC-DTM states);
- Radio link Failure;
- Cell selection and re-selection in Idle mode, in Group Receive mode, in GPRS mode and in broadcast/multicast receive mode (see 3GPP TS 43.022);
- CTS mode tasks.

NOTE: A distinction is made between *A/Gb mode* and *Iu mode* only when necessary. Procedures and mechanisms described in this TS apply to both modes of operation unless otherwise stated. In *Iu mode*, unless otherwise stated, DBPSCH covers TCH, PDTCH and FLO.

Handover is required to maintain a call in progress as a MS engaged in a point-to-point call or with access to the uplink of a channel used for a voice group call passes from one cell coverage area to another and may also be employed to meet network management requirements, e.g. relief of congestion.

Handover may occur during a call from one TCH or multiple TCHs (in the case of multislot configuration) to another TCH or multiple TCHs. It may also occur from DCCH to DCCH or from DCCH to one or multiple TCH(s), e.g. during the initial signalling period at call set-up. Additionally in *Iu mode*, handover may occur in MAC-Dedicated and MAC-DTM states:

- on PDTCH or multiple PDTCHs (in the case of multislot configuration) on DBPSCH(s) to another PDTCH or multiple PDTCHs on DBPSCH(s);
- for FLO, from one DBPSCH or multiple DBPSCHs (in the case of multislot configuration) to another DBPSCH or multiple DBPSCHs.

The handover may be either from channel(s) on one cell to other channel(s) on a surrounding cell, or between channels on the same cell which are carried on the same frequency band. Examples are given of handover strategies, however, these will be determined in detail by the network operator.

For a multiband MS, the handover described is also allowed between any channels on different cells which are carried on different frequency bands, e.g. between a GSM 900/TCH and a DCS 1 800/TCH. Handover between two co-located cells, carried on different frequency bands, is considered as inter-cell handover irrespective of the handover procedures used.

For a multi-RAT MS, i.e. an MS supporting multiple radio access technologies, handover is allowed between GSM and other radio access technologies.

NOTE: At handover, the MS will normally not be able to verify the PLMN of the target cell and will thus assume that the same system information apply after the handover unless the network provides new system information.

Adaptive control of the RF transmit power from an MS and optionally from the BSS is implemented in order to optimize the uplink and downlink performance and minimize the effects of co-channel interference in the system.

The criteria for determining radio link failure are specified in order to ensure that calls which fail either from loss of radio coverage or unacceptable interference are satisfactorily handled by the network. Radio link failure may result in either re-establishment or release of the call in progress. For channels used for a voice group call, a radio uplink failure results in the freeing up of the uplink.

Procedures for cell selection and re-selection whilst in Idle mode (i.e. not actively processing a call), are specified in order to ensure that a mobile is camped on a cell with which it can reliably communicate on both the radio uplink and downlink. The operations of an MS in Idle Mode are specified in 3GPP TS 43.022.

Cell re-selection is also performed by the MS when attached to GPRS, except when the MS simultaneously has a circuit switched connection. Optional procedures are also specified for network controlled cell re-selection for GPRS. Cell re-selection for GPRS is defined in subclause 10.1.

For a multi-RAT MS, cell selection and re-selection is allowed between GSM and other radio access technologies.

An MS listening to a voice group call or a voice broadcast use cell re-selection procedures to change cell. This may be supported by a list of cells carrying the voice group or voice broadcast call downlink, provided to the MS by the network. The operations of an MS in Group Receive Mode are specified in 3GPP TS 43.022.

Information signalled between the MS and BSS is summarized in tables 1, 2 and 3. A full specification of the Layer 1 header is given in 3GPP TS 44.004, of the Layer 3 fields in 3GPP TS 44.018 and 3GPP TS 44.118, and of the Layer 2 fields in 3GPP TS 44.060 and 3GPP TS 44.160.

For CTS, information signalled between the CTS-MS and CTS-FP is summarized in tables 4, 5 and 6. A full specification of the CTS Layer 3 fields is given in 3GPP TS 44.056.

For COMPACT, specific procedures are defined in clause 12.

During the reception of an MBMS session, the mobile station is in broadcast/multicast receive mode. In this state, the MS performs autonomous cell re-selection.

If the MS is a member of at least one Closed Subscriber Group, the MS may perform cell re-selection to CSG cells.

3 Handover

3.1 Overall process

The overall handover process is implemented in the MS, BSS and MSC. Measurement of radio subsystem downlink performance and signal levels received from surrounding cells, is made in the MS. These measurements are signalled to the BSS for assessment. The BSS measures the uplink performance for the MS being served and also assesses the signal level of interference on its idle traffic channels. Initial assessment of the measurements in conjunction with defined thresholds and handover strategy may be performed in the BSS. Assessment requiring measurement results from other BTS or other information resident in the MSC, may be performed in the MSC.

3GPP TS 23.009 describes the handover procedures to be used in PLMNs.

3.2 MS measurement procedure

A procedure shall be implemented in the MS by which it monitors the downlink RX signal level and quality from its serving cell and the downlink RX signal level and BSIC of surrounding BTS. The method of identification of surrounding BTS is described in subclause 7.2. The requirements for the MS measurements are given in subclause 8.1.

3.3 BSS measurement procedure

A procedure shall be implemented in the BSS by which it monitors the uplink RX signal level and quality from each MS being served by the cell. In the case of a multislot configuration the evaluation shall be performed on a timeslot per timeslot basis. A procedure shall be implemented by which the BSS monitors the levels of interference on its idle traffic channels.

3.4 Strategy

The handover strategy employed by the network for radio link control determines the handover decision that will be made based on the measurement results reported by the MS/BSS and various parameters set for each cell. Network directed handover may also occur for reasons other than radio link control, e.g. to control traffic distribution between cells. The exact handover strategies will be determined by the network operator, a detailed example of a basic overall algorithm appears in annex A. Possible types of handover are as follows:

Inter-cell handover:

Intercell handover from the serving cell to a surrounding cell will normally occur either when the handover measurements show low RXLEV and/or RXQUAL on the current serving cell and a better RXLEV available from a surrounding cell, or when a surrounding cell allows communication with a lower TX power level. This typically indicates that an MS is on the border of the cell area.

Intercell handover may also occur from the DCCH on the serving cell to a TCH or multislot configuration on another cell during call establishment. This may be used as a means of providing successful call establishment when no suitable TCH resource is available on the current serving cell.

Inter-cell handover between cells using different frequency bands is allowed for a multi band MS.

Inter-cell handover between cells using different radio access technologies is allowed for a multi-RAT MS.

Intra-cell handover:

Intra-cell handover from one channel/timeslot configuration in the serving cell to another channel/timeslot configuration in the same cell will normally be performed if the handover measurements show a low RXQUAL, but a high RXLEV on the serving cell. This indicates a degradation of quality caused by interference even though the MS is situated within the serving cell. The intra-cell handover should provide a channel with a lower level of interference. Intra-cell handover can occur either to a timeslot on a new carrier or to a different timeslot on the same carrier. Similarly, intra-cell handover may occur between different

multislot configurations in the same cell. These multislot configurations may comprise different number of timeslots and may partly overlap.

Intra-cell handover from one of the bands of operation to another one is allowed for a multiband MS.

3GPP TS 48.008 defines the causes for handover that may be signalled from BSS to MSC.

4 RF power control

4.1 Overall process

RF power control is employed to minimize the transmit power required by MS or BSS whilst maintaining the quality of the radio links. By minimizing the transmit power levels, interference to co-channel users is reduced.

4.2 MS implementation

RF power control shall be implemented in the MS.

In *A/Gb mode*, the power control level to be employed by the MS on each uplink channel, except PDCH, is indicated by means of the power control information sent either in the layer 1 header of each SACCH message block (see 3GPP TS 44.004) on the corresponding downlink channel, or in a dedicated signalling block (see 3GPP TS 44.018). Power control for PDCH is defined in subclause 10.2.

Similarly in *Iu mode* in MAC-Dedicated state and MAC-DTM state, the power control level to be employed by the MS on each uplink channel, is indicated by means of the power control information sent either in the layer 1 header of each SACCH message block (see 3GPP TS 44.004) on the corresponding downlink channel, or in a dedicated signalling block (see 3GPP TS 44.118). Power control for MAC-Shared state is defined in subclause 10.2.

The MS shall employ the most recently commanded power control level appropriate to each channel for all transmitted bursts on either a TCH (including handover access burst), FACCH, SACCH, PDTCH or SDCCH. For FLO in *Iu mode* the MS shall employ the most recently commanded power control level appropriate to each DBPSCH for all transmitted bursts (including radio packets, handover access burst and SACCH).

The MS shall confirm the power control level that it is currently employing in the SACCH L1 header on each uplink channel. The indicated value shall be the power control level actually used by the mobile for the last burst of the previous SACCH period.

When on an E-TCH, the MS shall, if so indicated by the BSS in the SACCH L1 header (see 3GPP TS 44.004) or Assignment command (see 3GPP TS 44.018 and 3GPP TS 44.118), use FPC (fast power control). The MS shall employ the most recently commanded fast power control level on each uplink E-TCH channel. The power control level to be employed by the MS is indicated by means of the power control information sent via E-IACCH once every FPC reporting period (see subclause 4.7). If FPC is in use, the MS shall report, in the SACCH L1 header, the power control level used at the end of the normal power control reporting period.

When on an E-TCH using 8 PSK for the uplink, the MS shall use the E-IACCH in the uplink for fast measurement reporting.

In *A/Gb mode*, when assigned a TCH or O-TCH, the MS shall configure the channel in enhanced power control (EPC) mode if so commanded by BSS in the channel assignment (see 3GPP TS 44.018). On such a channel, EPC may be used for uplink power control and/or downlink power control.

Similarly in *Iu mode*, when assigned a DBPSCH, the MS shall configure the channel in enhanced power control (EPC) mode if so commanded by BSS in the channel assignment (see 3GPP TS 44.118). On such a channel, EPC may be used for uplink power control and/or downlink power control.

The enhanced power control (EPC) is part of the GERAN Feature Package 2 (see 3GPP TS 24.008).

When on a channel in EPC mode,

- the MS shall use the EPCCH in the uplink for EPC measurement reporting (see subclause 8.4.1b).

- the MS shall, depending on what is signalled in the L1 header of the downlink SACCH (see 3GPP TS 44.004) and during channel assignment (see 3GPP TS 44.018), obey either the EPC Uplink Power Control Command (sent on the EPCCH in the downlink) or the Ordered MS Power Level (sent in the L1 header of the downlink SACCH).
 - If the signalling indicates that EPC shall be used in the uplink, the MS shall employ the most recently commanded EPC power control level, as indicated by the EPC Uplink Power Control Command sent on the corresponding EPCCH in the downlink. The EPC Uplink Power Control Command is sent once every EPC reporting period (see subclause 8.4.1b). The MS shall ignore the Ordered MS Power Level sent in the SACCH L1 header in the downlink.
 - If the signalling indicates that normal power control shall be used in the uplink, the MS shall ignore the EPC Uplink Power Control Command and use normal power control.
- the MS shall confirm, in the SACCH L1 header on the uplink, the RF power control level used at the last burst of the previous SACCH period, as specified for normal power control.

NOTE: The term "normal power control" is used in this specification only for clarification and is otherwise only referred to as "power control".

In case of a multislot configuration, each bi-directional channel shall be power controlled individually by the corresponding SACCH, E-IACCH or EPCCH, whichever is applicable. Power control information on downlink unidirectional channels shall be neglected.

When accessing a cell on the RACH (random access) and before receiving the first power command during a communication on a DCCH or TCH (after an IMMEDIATE ASSIGNMENT), on DCS 1800 and PCS 1900 frequency bands the MS shall use the power level defined by the MS_TXPWR_MAX_CCH parameter broadcast on the BCCH of the cell. On all other bands the MS shall limit the power level to LB_MS_TXPWR_MAX_CCH + Band_offset, if LB_MS_TXPWR_MAX_CCH parameter is broadcast, otherwise the power level is limited according to the MS_TXPWR_MAX_CCH parameter. Band_offset equals 0 dB for GSM 850 and GSM 900, -2 dB for GSM 700 and -6 dB for GSM 400. As an exception, on the DCS 1800 band the class 3 DCS 1800 capable MS shall use the power level defined by MS_TXPWR_MAX_CCH plus the value POWER_OFFSET also broadcast on the BCCH of the cell.

In addition, if the network indicates support for MS power reduction by broadcasting parameter INIT_PWR_RED (see 3GPP TS 44.018) and if the latest RLA-value, RLA_C or RLA_P (see section 6.1) for the measured signal strength from the BTS the MS is accessing is -48 dBm or higher immediately before the access attempt, the MS power shall not exceed

$$\text{PRED} = \min\{(\text{MS_TXPWR_MAX_CCH}, (\text{LB_MS_TXPWR_MAX_CCH} + \text{Band_offset}), (\text{P5-INIT_PWR_RED})\}$$

for GSM 400, GSM 700, T-GSM 810, GSM 850 and GSM 900 and

$$\text{PRED} = \min\{ \text{MS_TXPWR_MAX_CCH}, (\text{P0}+2\cdot\text{INIT_PWR_RED}) \}$$

for DCS 1800 and PCS 1900,

where P5 and P0 are the power control levels for respective band in 3GPP TS 45.005.

The power reduction only applies for the first transmission of the access burst on the RACH. If the initial transmission fails due to no response from the network, the MS shall not apply power reduction in remaining transmissions. The power reduction also applies for DCCH or TCH (after an IMMEDIATE ASSIGNMENT) under the same received signal strength conditions until the ordered power control level in the SACCH L1 header differs from MS_TXPWR_MAX_CCH or LB_MS_TXPWR_MAX_CCH + Band_offset, whichever is applicable or a L3 message with a valid power control command is received.

If INIT_PWR_RED is not broadcast, no power reduction shall apply.

If a power control level defined in 3GPP TS 45.005 is received but the level is not supported by the MS, the MS shall use the supported output power which is closest to the output power indicated by the received power control level.

4.3 MS power control range

The range over which a MS shall be capable of varying its RF output power shall be from its maximum output down to its minimum, in steps of nominally 2 dB.

3GPP TS 45.005 gives a detailed definition of the RF power level step size and tolerances.

In *A/Gb mode*, the fast power control scheme for E-TCH and the enhanced power control scheme for TCH and O-TCH are based on differential control to adjust the employed RF power level. Similarly in *Iu mode*, the fast power control scheme for E-TCH and the enhanced power control scheme for DBPSCH are also based on differential control to adjust the employed RF power level. The possible DL power control commands are listed in the following table.

Codeword	Power control command
0	Not used
1	Increase output power by four power control levels
2	Increase output power by three power control levels
3	Increase output power by two power control levels
4	Increase output power by one power control level
5	No output power level change
6	Decrease output power by one power control level
7	Decrease output power by two power control levels

If a power control command is received but the requested output power is not supported by the MS, the MS shall use the supported output power which is closest to the requested output power.

4.4 BSS implementation

In *A/Gb mode*, RF power control, including fast power control for E-TCH and enhanced power control for TCH and O-TCH, may optionally be implemented in the BSS.

Similarly in *Iu mode*, RF power control, including fast power control for E-TCH and enhanced power control for DBPSCH, may optionally be implemented in the BSS.

4.4.1 VAMOS subchannel power control for BSS in downlink

For a TCH in *VAMOS mode* in downlink, the BSS may optionally implement VAMOS subchannel specific power control. A BSS supporting VAMOS shall support AQPSK modulation with at least one value of α (see 3GPP TS 45.004).

4.5 BSS power control range

The range over which the BSS shall be capable of reducing its RF output power from its maximum level shall be nominally 30 dB, in 15 steps of nominally 2 dB.

3GPP TS 45.005 gives a detailed definition of the RF power level step size and tolerances.

4.6 Strategy

The RF power control strategy employed by the network determines the ordered power level that is signalled to the MS, and the power level that is employed by the BSS.

The power level to be employed in each case will be based on the measurement results reported by the MS/BTS and various parameters set for each cell. The exact strategies will be determined by the network operator. A detailed example of a basic algorithm appears in annex A.

4.7 Timing

4.7.1 Normal Power Control

Upon receipt of a command from an SACCH to change its power level on the corresponding uplink channel, the MS shall change to the new level at a rate of one nominal 2 dB power control step every 60 ms (13 TDMA frames), i.e. a range change of 15 steps should take about 900 ms. The change shall commence at the first TDMA frame belonging to the next reporting period (as specified in subclause 8.4). The MS shall change the power one nominal 2 dB step at a time, at a rate of one step every 60 ms following the initial change, irrespective of whether actual transmission takes place or not.

In case of channel change, except for multislot configuration change, the commanded power control level shall be applied on each new channel immediately. The multislot configuration change message does not command the MS to use new power control levels. For those time slots not used by the MS before the multislot configuration change procedure, the MS shall use the power control level used on the main channel before the multislot configuration change.

4.7.2 Fast Power Control

Switching between the normal power control mechanism and FPC shall be done if FPC is enabled or disabled via signalling in the SACCH L1 header. The respective power control mechanism to be used shall then be active as from the first TDMA frame belonging to the next reporting period (see subclause 8.4). The initial power control level to be used by the MS immediately after switching shall, in both cases, be the level last commanded by the normal power control mechanism.

The basic timing cycle for the fast power control mechanism is the FPC reporting period of length 4 TDMA frames, which is mapped into the 26-multiframe according to the following figure.

FN:	0	1	2	3	4	5	6	7	8	9	10	11	12	13	14	15	16	17	18	19	20	21	22	23	24	25
RP:	0	0	0	0	1	1	1	1	2	2	2	2	S	3	3	3	3	4	4	4	4	5	5	5	5	I

FN = TDMA Frame no modulo 26

RP = FPC reporting period number

DL measurements made during RP(n) shall be reported to the network during the next occurrence of $RP((n+2) \bmod 6)$. Power control commands received from the network during RP(n) are effectuated on the corresponding UL channel during the next occurrence of $RP((n+1) \bmod 6)$.

4.7.3 Enhanced Power Control

When in enhanced power control (EPC) mode, the MS shall for uplink power control obey either the EPC Uplink Power Control Commands or the Ordered MS Power Level. This is controlled by signalling via the SACCH L1 header in the downlink (see 3GPP TS 44.004) and during channel assignment (see 3GPP TS 44.018 and 3GPP TS 44.118). The type of power control commands to be obeyed by the MS during one SACCH period is determined by what is signalled in the L1 header during the previous SACCH period and, before any SACCH block has been correctly decoded, by what is signalled during channel assignment.

NOTE: This signalling via the SACCH L1 header and during channel assignment only controls the uplink power control mechanism. In *A/Gb mode*, EPC measurement procedures shall always be followed by the MS when on a TCH or O-TCH in EPC mode. Similarly in *Iu mode*, EPC measurement procedures shall always be followed by the MS when on a DBPSCH in EPC mode.

When the MS is ordered to obey the Ordered MS Power Level, the timing according to subclause 4.7.1 applies.

When the MS is ordered to obey the EPC Uplink Power Control Command, it shall, upon receipt of an EPC Uplink Power Control Command on an EPCCH in the downlink, change to the new power level on the corresponding

uplink channel at the first TDMA frame belonging to the next EPC reporting period (as specified in subclause 8.4.1b).

4.8 Dedicated channels used for a voice group call or voice broadcast

The network shall not allocate the uplink of the channel used for a voice group call to more than one MS. If marked busy, no other MS shall transmit on the channel. This marking is indicated by the network, as defined in 3GPP TS 43.068 and 3GPP TS 44.018. Any MS allocated the uplink of a channel used for a voice group call shall only transmit if the uplink is marked busy, and shall stop using the uplink if it happens to become marked free. An MS not allocated the uplink may perform a random access procedure on the uplink to gain access to talk, only if the uplink is marked as free.

On a channel used during a voice group call, the uplink power control shall only apply to the MS currently allocated that uplink, and the MS power control level ordered by the network shall be ignored by all other MSs listening to the downlink.

When performing a random access on a cell to gain access to the uplink of a channel used for a voice group call, until receiving the first dedicated power command from the network, the MS shall use the last received power level command as defined by the MS_TXPWR_MAX_CCH parameter broadcast on the BCCH of the cell, or if MS_TXPWR_MAX_CCH corresponds to a power control level not supported by the MS as defined by its power class in 3GPP TS 45.005, the MS shall act as though the closest supported power control level had been broadcast.

RF downlink power control will normally not be applied on channels used for a voice group call or voice broadcast.

5 Radio link failure

5.1 Criterion

The criterion for determining Radio Link Failure in the MS shall be based on the success rate of decoding messages on the downlink SACCH. In *A/Gb mode*, for a circuit switched multislot configuration, only the main SACCH shall be used for determining Radio Link Failure. Similarly in *Iu mode*, for a multislot configuration in MAC-Dedicated State or MAC-DTM State, only the main SACCH shall be used for determining Radio Link Failure.

For packet transfer mode in *A/Gb mode*, Radio Link Failure is determined by the RLC/MAC protocol (see 3GPP TS 44.060).

For *Iu mode* in MAC-Shared State, Radio Link Failure is determined by the RLC/MAC protocol (see 3GPP TS 44.160).

5.2 MS procedure

The aim of determining radio link failure in the MS is to ensure that calls with unacceptable voice/data quality, which cannot be improved either by RF power control or handover, are either re-established or released in a defined manner. In general the parameters that control the forced release should be set such that the forced release will not normally occur until the call has degraded to a quality below that at which the majority of subscribers would have manually released. This ensures that, for example, a call on the edge of a radio coverage area, although of bad quality, can usually be completed if the subscriber wishes.

The radio link failure criterion is based on the radio link counter *S*. If the MS is unable to decode a SACCH message ($BFI = 1$), *S* is decreased by 1. In the case of a successful reception of a SACCH message ($BFI = 0$) *S* is increased by 2. In any case *S* shall not exceed the value of RADIO_LINK_TIMEOUT. If *S* reaches 0 a radio link failure shall be declared. The action to be taken is specified in 3GPP TS 44.018 and 3GPP TS 44.118 (*Iu mode*). The RADIO_LINK_TIMEOUT parameter is transmitted by each BSS in the BCCH data (see table 1).

The MS shall continue transmitting as normal on the uplink until S reaches 0.

The algorithm shall start after the assignment of a dedicated channel and S shall be initialized to RADIO_LINK_TIMEOUT.

The detailed operation shall be as follows:

- the radio link time-out algorithm shall be stopped at the reception of a channel change command;
- (re-)initialization and start of the algorithm shall be done whenever the MS switches to a new dedicated channel (this includes the old channel in assignment and handover failure cases), at the latest in *A/Gb mode* when the main signalling link (see 3GPP TS 44.018) has been established or in *Lu mode* immediately after the MS is ready to receive (see 3GPP TS 44.118, 3GPP TS 45.010);
- the RADIO_LINK_TIMEOUT value used at (re-)initialization shall be that used on the previous channel (in the Immediate Assignment case the value received on the BCCH), or the value received on SACCH if the MS has received a RADIO_LINK_TIMEOUT value on the new channel before the initialization;
- if the first RADIO_LINK_TIMEOUT value on the SACCH is received on the new channel after the initialization, the counter shall be re-initialized with the new value.

An MS listening to a voice group call or a voice broadcast, upon a downlink radio link failure shall return to idle mode and perform cell re-selection.

5.3 BSS procedure

The criteria for determining radio link failure in the BSS should be based upon either the error rate on the uplink SACCH(s) or on RXLEV/RXQUAL measurements of the MS. The exact criteria to be employed shall be determined by the network operator.

For channels used for a voice group call, the radio link failure procedures in the BSS shall be reset upon the re-allocation of the uplink to another MS. Upon a uplink radio failure, the network shall mark it as free, see subclause 4.8.

Whenever the uplink is not used, and for channels used for voice broadcast, the BSS radio link failure procedures shall not apply on that channel.

6 Idle mode tasks

6.1 Introduction

Whilst in idle mode, an MS shall implement the cell selection and re-selection procedures described in 3GPP TS 43.022. These procedures make use of measurements and sub-procedures described in this subclause.

The procedures ensure that the MS is camped on a cell from which it can reliably decode downlink data and with which it has a high probability of communications on the uplink. Once the MS is camped on a cell, access to the network is allowed.

At cell selection, before accessing the network, the MS shall decode all information about dynamic mapping of ARFCN numbers, if used by the network. As an exception, a single access attempt (including repetitions allowed for channel request) is allowed using stored information that has been received from the same PLMN within last 24 hours. Alternatively a single access attempt is allowed using stored information, received from the same PLMN, without decoding all SI 15 instances if the Dynamic ARFCN Mapping change mark (See 3GPP TS 44.018) in the stored information is equal to that decoded from any of SI 15 instances. The MS shall always use the most recent information about Dynamic ARFCN Mapping.

This clause makes use of terms defined in 3GPP TS 43.022.

The MS shall not use the discontinuous reception (DRX) mode of operation (i.e. powering itself down when it is not expecting paging messages from the network) while performing the cell selection algorithm defined in 3GPP TS 43.022. However use of powering down is permitted at all other times in idle mode.

For the purpose of cell selection and reselection, the MS shall be capable of detecting and synchronizing to a BCCH carrier and read the BCCH data at reference sensitivity level and reference interference levels as specified in 3GPP TS 45.005. An MS in idle mode shall always fulfil the performance requirement specified in 3GPP TS 45.005 at levels down to reference sensitivity level or reference interference level. The allowed error rates (see 3GPP TS 45.005) might impact the cell selection and reselection procedure, e.g. trigger cell reselection. Moreover, one consequence of the allowed error rates is that in the case of no frequency hopping and a TU3 (TU6 for GSM 400, TU3.6 for GSM 700, TU1.5 for DCS 1 800 and PCS 1 900) propagation profile it can not be expected that an MS will respond to paging unless the received signal level is 2 dB higher than the specified reference level.

For the purposes of cell selection and reselection, the MS is required to maintain an average of received signal levels for all monitored frequencies. These quantities termed the "received level averages" (RLA_C), shall be unweighted averages of the received signal levels measured in dBm. The accuracy of the received signal level measurements for idle mode tasks shall be the same as for radio link measurements (see subclause 8.1.2).

If the MS camps on a GERAN cell as a result of a cell change order from E-UTRAN (see 3GPP TS 36.331) or redirection from E-UTRAN (see 3GPP TS 36.304), and system information for that cell is provided by the network in E-UTRAN, the MS may omit to acquire the system information from the BCCH before establishing a circuit switched connection if the conditions specified in 3GPP TS 44.018 are met.

For the specific case of CS Fallback by cell change order or redirection from E-UTRAN, if the MS camps on a suitable cell whose LAI is different to the one stored in the MS, the MS shall initiate a location updating or a combined routing area updating procedure as specified in 3GPP TS 24.008.

The times given in subclauses 6.2, 6.3 and 6.6 refer to internal processes in the MS required to ensure that the MS camps as quickly as possible to the most appropriate cell.

For the cell selection, the MS shall be able to select the correct (fourth strongest) cell and be able to respond to paging on that cell within 30 seconds of switch on, when the three strongest cells are not suitable. This assumes a valid SIM with PIN disabled and ideal radio conditions. This requirement is not applicable for multi-RAT mobile stations.

NOTE: Priorities between different frequencies or RATs provided to the MS by system information or by dedicated signalling are not used in the cell selection process.

The tolerance on all the timing requirements in clause 6 is $\pm 10\%$, except for PENALTY_TIME where it is $\pm 2\text{ s}$.

6.2 Measurements for normal cell selection

The measurements of this clause shall be performed by an MS which has no prior knowledge of which RF channels are BCCH carriers.

The MS shall search all RF channels within its bands of operation, take readings of received RF signal level on each RF channel, and calculate the RLA_C for each. The averaging is based on at least five measurement samples per RF carrier spread over 3 to 5 s, the measurement samples from the different RF carriers being spread evenly during this period.

A multi band MS shall search all channels within its bands of operation as specified above. The number of channels searched will be the sum of channels on each band of operation.

BCCH carriers can be identified by, for example, searching for frequency correction bursts. On finding a BCCH carrier, the MS shall attempt to synchronize to it and read the BCCH data.

The maximum time allowed for synchronization to a BCCH carrier is 0.5 s, and the maximum time allowed to read the BCCH data, when being synchronized to a BCCH carrier, is 1.9 s or equal to the scheduling period for the BCCH data, whichever is greater (see 3GPP TS 45.002). The MS is allowed to camp on a cell and access the cell after decoding all relevant BCCH data.

6.3 Measurements for stored list cell selection

The MS may include optional storage of BCCH carrier information when switched off as detailed in 3GPP TS 43.022. For example, the MS may store the BCCH carriers in use by the PLMN selected when it was last active in the network. The BCCH list may include BCCH carriers from more than one band in a multi band operation PLMN. A MS may also store BCCH carriers for more than one PLMN which it has selected previously (e.g. at

national borders or when more than one PLMN serves a country), in which case the BCCH carrier lists must be kept quite separate.

The stored BCCH carrier information used by the MS may be derived by a variety of different methods. The MS may use the BA_RANGE information element, which, if transmitted in the channel release message (see 3GPP TS 44.018), indicates ranges of carriers which include the BCCH carriers in use over a wide area or even the whole PLMN. It should be noted that the BA(BCCH) list might only contain carriers in use in the vicinity of the cell on which it was broadcast, and therefore might not be appropriate if the MS is switched off and moved to a new location.

The BA_RANGE information element contains the Number of Ranges parameter (defined as NR) as well as NR sets of parameters RANGEi_LOWER and RANGEi_HIGHER. The MS should interpret these to mean that all the BCCH carriers of the network have ARFCNs in the following ranges:

Range1 = ARFCN(RANGE1_LOWER) to ARFCN(RANGE1_HIGHER);
 Range2 = ARFCN(RANGE2_LOWER) to ARFCN(RANGE2_HIGHER);
 RangeNR = ARFCN(RANGENR_LOWER) to ARFCN(RANGENR_HIGHER).

If RANGEi_LOWER is greater than RANGEi_HIGHER, the range shall be considered cyclic and encompasses carriers with ARFCN from range RANGEi_LOWER to 1 023 and from 0 to RANGEi_HIGHER. If RANGEi_LOWER equals RANGEi_HIGHER then the range shall only consist of the carrier whose ARFCN is RANGEi_LOWER.

If an MS includes a stored BCCH carrier list of the selected PLMN it shall perform the same measurements as in subclause 6.2 except that only the BCCH carriers in the list need to be measured.

NOTE: If the selected PLMN is equal to one of the equivalent PLMNs, then stored list cell selection applies to all equivalent PLMNs.

If stored list cell selection is not successful, then as defined in 3GPP TS 43.022, normal cell selection shall take place. Since information concerning a number of channels is already known to the MS, it may assign high priority to measurements on the strongest carriers from which it has not previously made attempts to obtain BCCH information, and omit repeated measurements on the known ones.

6.4 Criteria for cell selection and reselection

The path loss criterion parameter C1 used for cell selection and reselection is defined by:

$$C1 = (A - \text{Max}(B, 0))$$

where

A = RLA_C - RXLEV_ACCESS_MIN
 B = MS_TXPWR_MAX_CCH - P

except for the class 3 DCS 1 800 MS where:

B = MS_TXPWR_MAX_CCH + POWER_OFFSET - P
 RXLEV_ACCESS_MIN = Minimum received signal level at the MS required for access to the system.
 MS_TXPWR_MAX_CCH = Maximum TX power level an MS may use when accessing the system until otherwise commanded.
 POWER_OFFSET = The power offset to be used in conjunction with the MS_TXPWR_MAX_CCH parameter by the class 3 DCS 1 800 MS.
 P = Maximum RF output power of the MS.

All values are expressed in dBm.

The path loss criterion (3GPP TS 43.022) is satisfied if $C1 > 0$.

The reselection criterion C2 is used for cell reselection only and is defined by:

$$C2 = C1 + \text{CELL_RESELECT_OFFSET} - \text{TEMPORARY_OFFSET} * H(\text{PENALTY_TIME} - T) \text{ for } \text{PENALTY_TIME} < 11111$$

$$C2 = C1 - \text{CELL_RESELECT_OFFSET} \text{ for } \text{PENALTY_TIME} = 11111$$

where

For non-serving cells:

$$H(x) = 0 \text{ for } x < 0$$

$$= 1 \text{ for } x \geq 0$$

For serving cells:

$$H(x) = 0$$

T is a timer implemented for each cell in the list of strongest carriers (see subclause 6.6.1). T shall be started from zero at the time the cell is placed by the MS on the list of strongest carriers, except when the previous serving cell is placed on the list of strongest carriers at cell reselection. In this, case, T shall be set to the value of PENALTY_TIME (i.e. expired).

CELL_RESELECT_OFFSET applies an offset to the C2 reselection criterion for that cell.

NOTE: CELL_RESELECT_OFFSET may be used to give different priorities to different bands when multiband operation is used.

TEMPORARY_OFFSET applies a negative offset to C2 for the duration of PENALTY_TIME after the timer T has started for that cell.

PENALTY_TIME is the duration for which TEMPORARY_OFFSET applies. The all ones bit pattern on the PENALTY_TIME parameter is reserved to change the sign of CELL_RESELECT_OFFSET and the value of TEMPORARY_OFFSET is ignored as indicated by the equation defining C2.

CELL_RESELECT_OFFSET, TEMPORARY_OFFSET, PENALTY_TIME and CELL_BAR_QUALIFY (see table 1a) are optionally broadcast on the BCCH of the cell. If not broadcast, the default values are CELL_BAR_QUALIFY = 0, and C2 = C1. The use of C2 is described in 3GPP TS 43.022.

These parameters are used to ensure that the MS is camped on the cell with which it has the highest probability of successful communication on uplink and downlink.

The signal strength threshold criterion parameter C4 is used to determine whether prioritised LSA cell reselection shall apply and is defined by:

$$C4 = A - \text{PRIO_THR}$$

where

A is defined as above and PRIO_THR is the signal threshold for applying LSA reselection. PRIO_THR is broadcast on the BCCH. If the idle mode support is disabled for the LSA (see 3GPP TS 51.011) or if the cell does not belong to any LSA to which the MS is subscribed or if no PRIO_THR parameter is broadcast, PRIO_THR shall be set to ∞ .

6.5 Downlink signalling failure

The downlink signalling failure criterion is based on the downlink signalling failure counter DSC. When the MS camps on a cell, DSC shall be initialized to a value equal to the nearest integer to $90/N$ where N is the BS_PA_MFRMS parameter for that cell (see 3GPP TS 45.002). Thereafter, whenever the MS attempts to decode a message in its paging subchannel; if a message is successfully decoded (BFI = 0) DSC is increased by 1, however never beyond the initial value, otherwise DSC is decreased by 4. When $DSC \leq 0$, a downlink signalling failure shall be declared.

An MS in packet idle mode or MAC-Idle state shall follow the same procedure. The counter DSC shall be initialized each time the MS enters packet idle mode or MAC-Idle state, respectively. In case DRX period split is supported, DSC shall be initialized to a value equal to the nearest integer to $\max(10, 90 * N_{\text{DRX}})$, where N_{DRX} is the average number of monitored blocks per multiframe in DRX mode according to its paging group (see 3GPP TS 45.002). In non-DRX mode, the MS shall only increment/decrement DSC for one block per DRX period according to its paging group. The exact position of these blocks is not essential, only the average rate.

NOTE: The network sends the paging subchannel for a given MS every BS_PA_MFRMS multiframes or, in case DRX period split is supported, every $1/N_{DRX}$ multiframes. The requirement for network transmission on the paging subchannel is specified in 3GPP TS 44.018 or 3GPP TS 44.060, 3GPP TS 44.118 or 3GPP TS 44.160. The MS is required to attempt to decode a message every time its paging subchannel is sent.

A downlink signalling failure shall result in cell reselection.

6.6 Measurements for Cell Reselection

Upon completion of cell selection and when starting the cell reselection tasks, the MS shall synchronize to and read the BCCH information for the 6 strongest non-serving carriers (in the BA) as quickly as possible within the times specified in subclause 6.6.1. For multi band MSs the strongest non-serving carriers may belong to different frequency bands. If system information message type 2 ter or 2 quater is used in the serving cell, and the MS has decoded all relevant serving cell BCCH data, except system information message 2 ter and/or 2 quater, then the MS shall start cell reselection measurements based on the know part of the BA, until system information message 2 ter and/or 2 quater is decoded and the full BA can be used.

MSs supporting SoLSA with SoLSA subscription shall perform cell re-selection according to subclause 6.6.3. Other MSs shall perform cell re-selection according to subclause 6.6.2.

MSs supporting other radio access technologies shall also perform measurements according to subclause 6.6.4 and cell-reselection according to subclause 6.6.5 or 6.6.6.

6.6.1 Monitoring of received signal level and BCCH data

Whilst in idle mode an MS shall continue to monitor all BCCH carriers as indicated by the BCCH allocation (BA - See table 1). A running average of received signal level (RLA_C) in the preceding 5 to:

$$\text{Max} \{ 5, ((5 * N + 6) \text{ DIV } 7) * \text{BS_PA_MFRMS} / 4 \}$$

seconds shall be maintained for each carrier in the BCCH allocation. N is the number of non-serving cell BCCH carriers in BA and the parameter BS_PA_MFRMS is defined in 3GPP TS 45.002.

The same number of measurement samples shall be taken for all non-serving cell BCCH carriers of the BA list, and the samples allocated to each carrier shall as far as possible be uniformly distributed over each evaluation period. At least 5 received signal level measurement samples are required per RLA_C value. New sets of RLA_C values shall be calculated as often as possible.

For the serving cell, received signal level measurement samples shall be taken at least for each paging block of the MS. The RLA_C shall be a running average determined using samples collected over a period of 5 s to $\text{Max} \{ 5s, \text{five consecutive paging blocks of that MS} \}$. The samples shall as far as possible be uniformly distributed over each evaluation period. At least 5 received signal level measurement samples are required per RLA_C value. New RLA_C values shall be calculated as often as possible.

The list of the 6 strongest non-serving carriers shall be updated at least as often as the duration of the running average defined for measurements on the BCCH allocation and may be updated more frequently.

In order to minimize power consumption, MS that employ DRX (i.e. power down when paging blocks are not due) should monitor the received signal levels of non-serving cell BCCH carriers during the frames of the paging block that they are required to listen to. The MS shall include the BCCH carrier of the current serving cell (i.e. the cell the MS is camped on) in this measurement routine. Received signal level measurement samples can thus be taken on several non-serving cell BCCH carriers and on the serving carrier during each paging block.

The MS shall attempt to decode the full BCCH data of the serving cell at least every 30 seconds or at least as often as possible in the case that system information scheduling period exceeds 30 seconds. As an exception, after the first attempt at cell selection, SI15, if used, shall be decoded at least once every 30 minutes.

If SI13 is broadcast, the MS supporting change mark in SI13 (See 3GPP TS 44.018) is only required to confirm system information on the BCCH of the serving cell if indicated by change mark in SI13.

The MS shall attempt to decode the BCCH data block that contains the parameters affecting cell reselection for each of the 6 strongest non-serving cell BCCH carriers at least every 5 minutes, if the parameters affecting cell reselection have not been provided by the network in the serving cell.

When the MS recognizes that a new BCCH carrier has become one of the 6 strongest, the BCCH data shall be decoded for the new carrier within 30 seconds, if the information is not already available.

If the network indicates that it supports the SI2n message in the serving cell, the MS in packet transfer mode or broadcast/multicast receive mode shall not interrupt data transfer by attempting to autonomously decode the BCCH data block that contains the parameters affecting cell reselection, from non-serving cells. However, if relevant reselection parameters are not received from the serving cell within 30 seconds after reselecting a new cell, the MS shall revert to autonomous decoding of parameters from non-serving cells.

The MS shall attempt to check the BSIC for each of the 6 strongest non-serving cell BCCH carriers at least every 30 seconds, to confirm that it is monitoring the same cell. If a change of BSIC is detected then the carrier shall be treated as a new carrier and the BCCH data re-determined.

For an MS supporting network sharing (see 3GPP TS 44.018 [17], 3GPP TS 23.251 [45] and 3GPP TS 24.008 [46]), only cells with allowed BSIC shall be considered for reselection. The allowed BSIC is either a valid BSIC with a permitted NCC part or, for cells in BA(BCCH) where no BSIC is broadcast, a BSIC with a permitted NCC part (see subclause 7.2).

In addition, an MS supporting SoLSA with SoLSA subscription shall attempt to decode BSIC and the BCCH data blocks that contain the parameters affecting SoLSA cell reselection for the 6 strongest carriers, which are included both in the BCCH allocation and in the BA_PREF as received in the latest CHANNEL RELEASE message (see 3GPP TS 44.018). At least one carrier shall be searched every 5 minutes, one after another. In the case the MS has been able to decode the BCCH data blocks, the rules described in subclause 6.6.3 shall be followed.

When requested by the user, the MS shall determine which PLMNs are available (Manual Mode) or available and allowable (Automatic Mode) (see 3GPP TS 43.022) within 10 seconds (for GSM 450), 10 seconds (for GSM 480), 15 seconds (for GSM 700), 15 seconds (for GSM 850 and GSM 900) or 20 seconds (for DCS 1 800 and PCS 1 900). A multi band MS shall perform the same procedures in all bands of operation within the sum of time constraints in the respective band of operation.

In both cases, this monitoring shall be done so as to minimize interruptions to the monitoring of the PCH.

The maximum time allowed for synchronization to a BCCH carrier is 0,5 s, and the maximum time allowed to read the BCCH data, when being synchronized to a BCCH carrier, is 1,9 s or equal to the scheduling period for the BCCH data, whichever is greater (see 3GPP TS 45.002).

6.6.2 Path loss criteria and timings for cell re-selection

The MS is required to perform the following measurements (see 3GPP TS 43.022) to ensure that the path loss criterion to the serving cell is acceptable.

At least every 5 s the MS shall calculate the value of C1 and C2 for the serving cell and re-calculate C1 and C2 values for non serving cells (if necessary). The MS shall then check whether:

- i) The path loss criterion (C1) for current serving cell falls below zero for a period of 5 seconds. This indicates that the path loss to the cell has become too high.
- ii) The calculated value of C2 for a non-serving suitable cell exceeds the value of C2 for the serving cell for a period of 5 seconds, except;
 - a) in the case of the new cell being in a different location area or, for a GPRS attached MS, in a different routing area or always for a GPRS attached MS in GMM Ready state (*A/Gb mode*) or RRC-Cell_Shared state (*lu mode*) in which case the C2 value for the new cell shall exceed the C2 value of the serving cell by at least CELL_RESELECT_HYSTERESIS dB as defined by the BCCH data from the current serving cell, for a period of 5 seconds; or
 - b) in case of a cell reselection occurring within the previous 15 seconds in which case the C2 value for the new cell shall exceed the C2 value of the serving cell by at least 5 dB for a period of 5 seconds.

This indicates that it is a better cell.

Cell reselection for any other reason (see 3GPP TS 43.022) shall take place immediately, but the cell that the MS was camped on shall not be returned to within 5 seconds if another suitable cell can be found. If valid RLA_C values are not available, the MS shall wait until these values are available and then perform the cell reselection if it is still required. The MS may accelerate the measurement procedure within the requirements in subclause 6.6.1 to minimize the cell reselection delay.

If no suitable cell is found within 10 seconds, the cell selection algorithm of 3GPP TS 43.022 shall be performed. Since information concerning a number of channels is already known to the MS, it may assign high priority to measurements on the strongest carriers from which it has not previously made attempts to obtain BCCH information, and omit repeated measurements on the known ones.

6.6.3 Cell reselection algorithm for SoLSA

At least for every new sample or every second, whichever is the greatest, the MS calculate the value of C1, C2 and C4 for the serving cell and the non-serving cells. The MS shall make a cell reselection if:

- i) The path loss criterion parameter (C1) for the serving cell falls below zero for a period of 5 seconds.
- ii) A non-serving suitable cell (see 3GPP TS 43.022) is evaluated to be better than the serving cell for a period of 5 seconds. The best cell is
 - the cell with the highest value of $C2 + \text{LSA_OFFSET}$ among those cells that have highest LSA priority among those that fulfil the criteria $C4 \geq 0$, or
 - the cell with the highest value of C2 among all cells, if no cell fulfil the criterion $C4 \geq 0$.

LSA_OFFSET is broadcast on BCCH. If no LSA_OFFSET parameter is broadcast, LSA_OFFSET shall be set to 0.

LSA priority is defined by the list of LSAs for the subscriber stored on the SIM (see 3GPP TS 51.011). LSAs are identified by LSA ID(s), Cell Identity and/or Location Area Identity broadcast on BCCH. Cells not belonging to this list are given LSA priority lower than 0.

When evaluating the best cell, the following hysteresis values shall be subtracted from the C2 value for the neighbour cells:

- if the new cell is in the same location area: 0;
- if the new cell is in a different location area:
CELL_RESELECT_HYSTERESIS, which is broadcast on BCCH of the serving cell.
- in case of a cell reselection occurred within the previous 15 seconds: 5 dB.

Cell reselection for any other reason (see 3GPP TS 43.022) shall take place immediately, but the cell that the MS was camped on shall not be returned to within 5 seconds if another suitable cell can be found. If valid receive level averages are not available, the MS shall wait until these values are available and then perform the cell reselection if it is still required. The MS may accelerate the measurement procedure within the requirements in subclause 6.6.1 to minimise the cell reselection delay.

If no suitable cell is found within 10 seconds, the cell selection algorithm of 3GPP TS 43.022 shall be performed. Since information concerning a number of channels is already known to the MS, it may assign high priority to measurements on the strongest carriers from which it has not previously made attempts to obtain BCCH information, and omit repeated measurements on the known ones.

6.6.4 Measurements on cells of other radio access technologies

For a multi-RAT MS, cells or frequencies with other radio access technologies (excluding E-UTRA) may be included in 3G Cell Reselection list (see 3GPP TS 44.018). If cell reselection based on ranking is used, the network controls the measurements for reselection of these cells by the parameter Qsearch_I broadcast on BCCH. Qsearch_I defines a threshold and also indicates whether these measurements shall be performed when RLA_C (see subclause 6.6.1) of the serving cell is below or above the threshold. These measurements may be performed less frequently than measurements of GSM cells as described in subclause 6.6.1, in order to conserve MS power.

For a multi-RAT MS supporting E-UTRA, E-UTRAN frequencies may be included in the E-UTRAN Neighbour Cell list (see 3GPP TS 44.018). The network controls the measurements for reselection of E-UTRA cells by the parameter THRESH_priority_search broadcast on BCCH. This parameter also controls measurement of inter-RAT cells or frequencies included in the 3G Cell Reselection list when the inter-RAT cell reselection algorithm based on priority information is used (see subclause 6.6.6). The mobile station shall monitor cells of inter-RAT frequencies of higher priority than the serving cell. When RLA_C of the serving cell is below THRESH_priority_search, the mobile station shall monitor cells of inter-RAT frequencies of lower priority than the serving cell. When RLA_C (see subclause 6.6.1) of the serving cell is above the threshold, the mobile station is allowed not to monitor cells of inter-RAT frequencies of lower priority than the serving cell.

The MS shall perform the measurement processes for E-UTRAN and other access technologies in parallel when applicable.

A UTRAN capable MS shall be able to identify and select a new best UTRAN cell on a frequency, which is part of the 3G Cell Reselection list, within 30 seconds (in case of cell reselection based on cell ranking) or $25+T_{\text{reselection}}$ seconds (in case of cell reselection based on priority information, if the UTRAN frequency has lower priority than the serving cell and if RLA_C of the serving cell is below THRESH_priority_search) after it has been activated under the condition that there is only one UTRAN frequency in the list (and no E-UTRAN frequencies in the E-UTRAN Neighbour Cell list) and that no new GSM cells are activated at the same time and under good radio conditions. As an exception, the time is increased to $70+T_{\text{reselection}}$ seconds in case of a UTRAN capable MS performing cell reselection based on priority information (see subclause 6.6.6) if the UTRAN frequency has higher priority than the serving cell. A E-UTRAN capable MS shall be able to identify and select a new best E-UTRAN cell on a frequency, which is part of the E-UTRAN Neighbour Cell list, within $25+T_{\text{reselection}}$ seconds after it has been activated if the frequency has lower priority than the serving cell and if RLA_C of the serving cell is below THRESH_priority_search, or within $70+T_{\text{reselection}}$ seconds after it has been activated if the frequency has higher priority than the serving cell, under the condition that there is only one E-UTRAN frequency in the list (and no UTRAN frequencies in the 3G Cell Reselection list) and that no new GSM cells are activated at the same time and under good radio conditions. For test purposes the following radio conditions can be used: Serving GSM cell at RXLEV= -70 dBm, with 6 GSM neighbours at RXLEV= -75 dBm. Then either an UTRAN FDD neighbour cell or an UTRAN TDD neighbour cell or an E-UTRAN FDD neighbour cell or an E-UTRAN TDD neighbour cell is switched on. The radio conditions for the UTRAN FDD cell are as follows (see 3GPP TS 25.101 for definitions):

Parameter	Unit	UTRAN FDD Cell
<i>CPICH_Ec/Ior</i>	dB	-10
<i>P-CCPCH_Ec/Ior</i>	dB	-12
<i>SCH_Ec/Ior</i>	dB	-12
<i>PICH_Ec/Ior</i>	dB	-15
<i>DPCH_Ec/Ior</i>	dB	$-\infty$
<i>OCNS_Ec/Ior</i>	dB	-0.94
\hat{I}_{or}/I_{oc}	dB	10
<i>I_{oc}</i>	dBm/3.84 MHz	-70
<i>CPICH_Ec/Io</i>	dB	-10.4
<i>CPICH_RSCP</i>	dBm	-70
FDD_Qoffset	integer	5 (-12dB)
FDD_Qmin	integer	7 (-12dB)
FDD_Qmin_Offset	integer	0 (0 dB)
FDD_RSCPmin	integer	6 (-102 dBm)
Qsearch_I	integer	7 (search always)
Propagation Condition	AWGN	

NOTE: The parameters in the table above are valid only for cell reselection based on cell ranking.

The radio conditions for the UTRAN TDD cell (either 3.84 Mcps TDD option or 1.28 Mcps TDD option) are as follows (see 3GPP TS 25.123 for definitions and for the values of the remaining configuration parameters):

Parameter	Unit	UTRAN TDD Cell (3.84 Mcps option)	
<i>Timeslot Number</i>		0	8
<i>P-CCPCH_Ec/Ior</i>	dB	-3	
<i>SCH_Ec/Ior</i>	dB	-9	-9
<i>SCH_{t_offset}</i>	integer	0	0
<i>PICH_Ec/Ior</i>	dB		-3
<i>OCNS_Ec/Ior</i>	dB	-3.12	-3.12
<i>PCCPCH RSCP</i>	dBm	-70	-70
TDD_Qoffset	integer	5 (-90dBm)	
Qsearch_I	integer	7 (search always)	
Propagation Condition	AWGN		

NOTE: On timeslot 8 the P-CCPCH is not transmitted; on that timeslot, the P-CCPCH RSCP defines the power level of the beacon channel.

NOTE: The parameters in the table above are valid only for cell reselection based on cell ranking.

Parameter	Unit	UTRAN TDD Cell (1.28 Mcps option)	
<i>Timeslot Number</i>		0	DwPTS
<i>P-CCPCH_Ec/Ior</i>	dB	-3	
<i>DwPCH_Ec/Ior</i>	dB		0
<i>OCNS_Ec/Ior</i>	dB	-3	
<i>P-CCPCH RSCP</i>	dBm	-70	
TDD_Qoffset	integer	5 (-90dBm)	
Qsearch_I	integer	7 (search always)	
Propagation Condition	AWGN		

NOTE: The parameters in the table above are valid only for cell reselection based on cell ranking.

The radio conditions for the E-UTRAN FDD cell are as follows (see 3GPP TS 36.101 for definitions):

Parameter	Unit	E-UTRAN FDD Cell
<i>Channel Bandwidth</i>	MHz	10
<i>PSS_RB, SSS_RB, PBCH_RA, PBCH_RB, PCFICH_RA, PHICH_RA, PHICH_RB, PDCCH_RA, PDCCH_RB, PDSCH_RA, PDSCH_RB</i>	dB	0
<i>OCNG_RA</i> (Note 1)	dB	0
<i>OCNG_RB</i> (Note 1)	dB	0
<i>RSRP</i>	dBm/15kHz	-86
\hat{E}_s/I_{ot}	dB	12
N_{oc}	dBm/15kHz	-98
E-UTRAN_QRXLEVMIN	integer	0 (-140 dBm)
THRESH_priority_search	integer	15 (search always)
T_reselection	integer	0 (5 s)
THRESH_E-UTRAN_high	integer	24 (48 dB)
E-UTRAN_PRIORITY	integer	higher than GERAN_PRIORITY
OCNG pattern	OP.2 FDD (see 3GPP TS 36.133)	
MIMO configuration	single transmitter	
Propagation Condition	AWGN	
NOTE 1: OCNG shall be used such that the E-UTRAN cell is fully allocated and a constant total transmitted power spectral density is achieved for all OFDM symbols.		

NOTE: The parameters in the table above are valid if THRESH_E-UTRAN_high_Q is not signalled.

The radio conditions for the E-UTRAN TDD cell are as follows (see 3GPP TS 36.101 for definitions):

Parameter	Unit	E-UTRAN TDD Cell
<i>Channel Bandwidth</i>	MHz	10
<i>PSS_RB, SSS_RB, PBCH_RA, PBCH_RB, PCFICH_RA, PHICH_RA, PHICH_RB, PDCCH_RA, PDCCH_RB, PDSCH_RA, PDSCH_RB</i>	dB	0
<i>OCNG_RA</i> (Note 1)	dB	0
<i>OCNG_RB</i> (Note 1)	dB	0
<i>RSRP</i>	dBm/15kHz	-86
\hat{E}_s/I_{ot}	dB	12
N_{oc}	dBm/15kHz	-98
E-UTRAN_QRXLEVMIN	integer	0 (-140 dBm)
THRESH_priority_search	integer	15 (search always)
T_reselection	integer	0 (5 s)
THRESH_E-UTRAN_high	integer	24 (48 dB)
E-UTRAN_PRIORITY	integer	higher than GERAN_PRIORITY
OCNG pattern	OP.2 TDD (see 3GPP TS 36.133)	
MIMO configuration	single transmitter	
Propagation Condition	AWGN	
NOTE 1: OCNG shall be used such that the E-UTRAN cell is fully allocated and a constant total transmitted power spectral density is achieved for all OFDM symbols.		

NOTE: The parameters in the table above are valid if THRESH_E-UTRAN_high_Q is not signalled.

The allowed time is increased

- by 30 seconds for each additional UTRAN frequency in the 3G Cell Reselection list when the reselection algorithm based on ranking is used, or
- by 30 seconds for each additional UTRAN frequency of lower priority in the 3G Cell Reselection list when the reselection algorithm based on priority information is used or for each additional E-UTRAN frequency of lower priority in the E-UTRAN Neighbour Cell list under the condition that RLA_C of the serving cell is below THRESH_priority_search, or
- by 70 seconds for each additional UTRAN frequency of higher priority in the 3G Cell Reselection list when the reselection algorithm based on priority information is used or for each additional E-UTRAN frequency of higher priority in the E-UTRAN Neighbour Cell list.

However, multiple UTRAN cells on the same frequency in the 3G Cell Reselection list does not increase the allowed time.

NOTE: The requirements above assume that only one of the frequencies in the 3G Cell Reselection list or in the E-UTRAN Neighbour Cell list is switched on.

A multi-RAT MS shall be able to monitor cells from other radio access technologies, divided into (depending on the MS capability):

- UTRAN FDD cells on up to 3 FDD frequencies, with a maximum of 32 cells per frequency; and/or
- UTRAN TDD cells on up to 3 TDD frequencies with a maximum of 32 cells per frequency; and/or
- E-UTRAN FDD cells on up to 3 FDD frequencies; and/or
- E-UTRAN TDD cells on up to 3 TDD frequencies.

The total number of monitored UTRAN cells shall not exceed 64.

The MS shall be capable of performing RSCP and E_c/N_o measurements of at least 4 best UTRAN cells per UTRAN frequency and RSRP and RSRQ measurements of at least 4 best E-UTRAN cells per E-UTRAN frequency, according to its supported capabilities.

The MS shall attempt to read and store UTRAN predefined configurations using the rules defined in 3GPP TS 25.331 with the following exceptions:

- The MS shall build a list of at most 16 predefined configurations, read from the BCCH of the identified UTRAN cells of equivalent PLMNs.
- After PLMN selection (see 3GPP TS 23.122), the MS shall delete any old list of predefined configurations and as soon as possible attempt to read the predefined configurations from one identified UTRAN cell of the selected PLMN or of an equivalent PLMN.
- The MS shall attempt to update the list of predefined configurations every 60 minutes.

In case of a conflict with GSM tasks, the GSM tasks take precedence.

NOTE: Instead of reading new predefined configurations from a PLMN, the MS may use previously received predefined configurations for that PLMN according to the rules in 3GPP TS 25.331.

The MS shall report the list of predefined configurations in the UTRAN CLASSMARK CHANGE message (see 3GPP TS 44.018).

If the MS has no or an empty CSG Whitelist and information about PSC/PCI split information for UTRAN/EUTRAN frequencies is available, the MS shall disable the measurement of the cells on the frequencies with PSC/PCI in the stored range "CSG PSC/PCI Split Information".

If the MS has no or an empty CSG Whitelist and information about dedicated frequencies for UTRAN/EUTRAN is available, the MS shall disable the measurement for cells on dedicated CSG frequencies.

6.6.5 Algorithm for cell re-selection from GSM to UTRAN based on cell ranking

The algorithm in this subclause shall be used for reselection from GSM to UTRAN if the conditions for the use of the cell reselection algorithm based on priority information (see subclause 6.6.6) are not satisfied.

If the 3G Cell Reselection list includes UTRAN frequencies, the MS shall, at least every 5 s update the value RLA_C for the serving cell and each of the at least 6 strongest non serving GSM cells.

The MS shall then reselect a suitable (see 3GPP TS 25.304) UTRAN cell if:

- for a TDD cell the measured RSCP value is equal to or greater than TDD_Qoffset for a period of 5 s and
- for an FDD cell the following criteria are all met for a period of 5 s:
 1. its measured RSCP value exceeds the value of RLA_C for the serving cell and all of the suitable (see 3GPP TS 43.022) non-serving GSM cells by the value FDD_Qoffset,
 2. its measured Ec/No value is equal or greater than the value FDD_Qmin - FDD_Qmin_Offset, and
 3. its measured RSCP value is equal to or greater than FDD_RSCP_threshold.

In case of a cell reselection occurring within the previous 15 seconds, FDD_Qoffset or TDD_Qoffset is increased by 5 dB.

- Ec/No and RSCP are the measured quantities, see subclause 8.1.5.
- FDD_RSCP_threshold equals FDD_RSCPmin – min((P_MAX – 21 dBm), 3 dB) if FDD_RSCPmin is broadcast on the serving cell, else Qrxlev_min + Pcompensation + 10 dB, if these parameters are available, otherwise the default value of FDD_RSCPmin.
- Qrxlev_min is the minimum required RX level in the UTRAN FDD cell (dBm), see 3GPP TS 25.304.
- Pcompensation is max(UE_TXPWR_MAX_RACH – P_MAX, 0) (dB), see 3GPP TS 25.304.
- UE_TXPWR_MAX_RACH is the maximum TX power level an MS may use when accessing the UTRAN FDD cell on RACH (dBm), see 3GPP TS 25.304.
- P_MAX is the maximum RF output power of the MS (dBm) in UTRAN FDD mode, see 3GPP TS 25.304.

- FDD_Qmin, FDD_Qoffset and optionally FDD_RSCPmin and FDD_Qmin_Offset are broadcast on BCCH of the serving cell.
- TDD_Qoffset is broadcast on BCCH of the serving cell.

Note 1: The parameters required to determine if the UTRAN cell is suitable are broadcast on BCCH of the UTRAN cell. An MS may start reselection towards the UTRAN cell before decoding the BCCH of the UTRAN cell, leading to a short interruption of service if the UTRAN cell is not suitable.

Note 2: If FDD_RSCPmin is broadcast, optimum GSM to UTRAN reselection performance is achieved if UTRAN cells at UTRAN coverage border areas are planned for +24 dBm UE power.

Note 3: The parameter TDD_Qoffset is an absolute threshold for reselection towards a target UTRAN TDD cell.

The MS shall store the UTRAN cell RSCP suitability criterion parameters above, whenever decoded from a UTRAN FDD cell, which is not a CSG cell, of a PLMN which is the registered PLMN or is in the stored list of equivalent PLMNs (see 3GPP TS 24.008) while attempting to camp on the UTRAN FDD cell. The mobile station shall store, along with decoded RSCP suitability parameters, the frequency of the cell from which they were decoded. The most recently stored parameters from a UTRAN FDD cell (other than a CSG cell) of an equivalent PLMN (including the registered PLMN) operating on the same frequency as the candidate cell are valid reselection criteria towards any candidate UTRAN FDD cell evaluated using the algorithm in this sub-clause. This list of parameters shall be cleared after PLMN selection (see 3GPP TS 23.122).

Cell reselection to UTRAN shall not occur within 5 seconds after the MS has reselected a GSM cell from an UTRAN cell if a suitable GSM cell can be found.

In case of a reselection attempt towards a barred UTRAN cell, the MS shall abandon further reselection attempts towards this UTRAN cell as defined by the T_{barred} value on the barred UTRAN cell (see 3GPP TS 25.331).

In case the highest ranked UTRAN cell is not suitable (see 3GPP TS 25.304) due to being part of the "list of forbidden LAs for roaming" or belonging to a PLMN which is not indicated as being equivalent to the registered PLMN, the MS may abandon further reselection attempts towards this UTRAN cell and all other cells on the same frequency, for a period of up to 20 min. If the MS has to perform cell selection, this limitation shall be removed. If the MS is redirected under GERAN control to a frequency for which the timer is running, any limitation on that frequency shall be removed.

If more than one UTRAN cell fulfils the above criteria, the MS shall select the cell with the greatest RSCP value.

6.6.6 Algorithm for inter-RAT cell re-selection based on priority information

A mobile station supporting E-UTRAN shall support priority based inter-RAT cell re-selection towards all the supported RATs. A mobile station not supporting E-UTRAN and supporting UTRAN and supporting priority based reselection from UTRAN to GERAN (see 3GPP TS 25.306) shall support priority based inter-RAT cell re-selection towards UTRAN.

The algorithm in this sub-clause shall be used for inter-RAT cell reselection if the following conditions are satisfied:

- the mobile station supports priority based inter-RAT cell re-selection, and
- the mobile station has received the Serving Cell Priority Parameters Description IE (see 3GPP TS 44.018 and 3GPP TS 44.060) for the serving cell.

If one or both of these conditions are not met, then inter-RAT reselection to E-UTRAN cells is not permitted, and inter-RAT reselection to UTRAN cells shall use the algorithm specified in sub-clause 6.6.5.

The set of valid priorities to be used for this algorithm is specified in 3GPP TS 44.018 and 3GPP TS 44.060. Cells belonging to frequencies for which no valid priority is available or no threshold is provided by the serving cell shall not be considered for measurement and for cell re-selection.

NOTE 1: The network may enable priority based reselection by providing in the serving cell at least the Serving Cell Priority Parameters Description struct and priority information (threshold and priority) for each inter-RAT frequency in the neighbour cell list to which the possibility of reselection by a mobile station using this algorithm is desired (whether or not such cells support priority-based reselection).

NOTE 2: Throughout the specification, the phrase “neighbour cell list” will include also the E-UTRAN Neighbour Cell list where appropriate.

NOTE 3: void

If the 3G Cell Reselection list or the E-UTRAN Neighbour Cell list include frequencies of other radio access technologies, the MS shall, at least every 5 s update the value RLA_C for the serving cell and each of the at least 6 strongest non serving GSM cells.

The MS shall then reselect a suitable (see 3GPP TS 25.304 for UTRAN and 3GPP TS 36.304 for E-UTRAN) cell of another radio access technology if the criteria below are satisfied. $S_{\text{non-serving_XXX}}$ is the measurement quantity of a non-serving inter-RAT cell and XXX indicates the other radio access technology/mode and is defined as follows:

- for a UTRAN cell, is the measured RSCP value for the cell minus UTRAN_QRXLEVMIN for the cell's frequency;
- for a E-UTRAN cell, is the measured RSRP value for the cell minus E-UTRAN_QRXLEVMIN for the cell's frequency if THRESH_E-UTRAN_high_Q is not provided; otherwise, if THRESH_E-UTRAN_high_Q is provided, is the measured RSRQ value for the cell minus E-UTRAN_QQUALMIN for the cell's frequency.

For a GSM cell, S_{GSM} is defined as the C1 value for the cell (see subclause 6.4);

Cell reselection to a cell of another inter-RAT frequency shall be performed if any of the conditions below (to be evaluated in the order shown) is satisfied:

- The $S_{\text{non-serving_XXX}}$ of one or more cells of a higher priority inter-RAT frequency is greater than THRESH_XXX_high (or, in case of an E-UTRAN target, THRESH_E-UTRAN_high_Q, if provided) during a time interval $T_{\text{reselection}}$; in that case, the mobile station shall consider the cells for reselection in decreasing order of priority and, for cells of the same priority, in decreasing order of $S_{\text{non-serving_XXX}}$, and reselect the first cell that satisfies the conditions above;
- The value of S_{GSM} is lower than THRESH_GSM_low for the serving cell and all measured GSM cells during a time interval $T_{\text{reselection}}$; in this case, the mobile station shall consider for reselection the inter-RAT cells in the following order, and reselect the first one that satisfies the following criteria:
 - cells of a lower priority inter-RAT frequency whose $S_{\text{non-serving_XXX}}$ is greater than THRESH_XXX_low (or, in case of an E-UTRAN target, THRESH_E-UTRAN_low_Q, if provided) during a time interval $T_{\text{reselection}}$; these cells shall be considered in decreasing order of priority and, for cells of the same priority, in decreasing order of $S_{\text{non-serving_XXX}}$;
 - if no cells satisfy the criterion above, inter-RAT cells for which, during a time interval $T_{\text{reselection}}$, $S_{\text{non-serving_XXX}}$ is higher than S_{GSM} for the serving cell by at least a specific hysteresis H_{PRIO} ; these cells shall be considered in decreasing order of $S_{\text{non-serving_XXX}}$.

A UTRAN FDD cell shall only be reselected if, in addition to the criteria above, its measured E_c/N_0 value is equal to or greater than $FDD_Q_{\text{min}} - FDD_Q_{\text{min_Offset}}$.

If E-UTRAN_Qmin is provided for a E-UTRAN frequency, a E-UTRAN cell on that frequency shall only be reselected if, in addition to the criteria above, its measured RSRQ value is equal to or greater than E-UTRAN_Qmin.

If THRESH_E-UTRAN_high_Q is provided for a E-UTRAN frequency, and if E-UTRAN_RSRPmin is provided, a E-UTRAN cell on that frequency shall only be reselected if, in addition to the criteria above, its measured RSRP value is equal to or greater than E-UTRAN_RSRPmin. If E-UTRAN_RSRPmin is not provided, the default value shall be used.

If the MS does not support RSRQ based reselection from E-UTRAN (see 3GPP TS 36.304), cell reselection from GERAN to E-UTRAN shall be based on the RSRP criterion according to the rules above without considering THRESH_E-UTRAN_high_Q (i.e. as in the case when THRESH_E-UTRAN_high_Q is not provided).

E-UTRAN cells which are included in the list of not allowed cells shall not be considered as candidates for cell reselection. If the strongest cells on a E-UTRAN frequency are included in the list of not allowed cells, the mobile station may reselect the strongest valid cell (see subclause 8.4.7) on that frequency.

Cell reselection to a cell of another radio access technology (e.g. UTRAN or E-UTRAN) shall not occur within 5 seconds after the MS has reselected a GSM cell from an inter-RAT cell if a suitable GSM cell can be found.

If a mobile station in *camped normally* state (see 3GPP TS 43.022) has valid individual priorities which do not include a priority for the serving cell, the mobile station shall consider the serving cell to have lowest priority (i.e. lower than the eight network configured values).

A mobile station in *camped on any cell* state (see 3GPP TS 43.022) shall ignore individual priorities received through dedicated signalling and shall apply priorities received from the system information of the serving cell while attempting to find a suitable cell. If the mobile station supports CS voice services, the MS shall avoid reselecting acceptable (but not suitable) E-UTRA cells regardless of the priorities provided in system information.

NOTE 4: If the MS is camping on an acceptable cell, individual priorities are not discarded until an event leading to their deletion occurs.

In case of a reselection attempt towards a barred UTRAN cell, the MS shall abandon further reselection attempts towards this UTRAN cell as defined by the T_{barred} value on the barred UTRAN cell (see 3GPP TS 25.331).

In case of a reselection attempt towards a barred E-UTRAN cell, the MS shall abandon further reselection attempts towards this E-UTRAN cell for a period of up to 20 min.

In case the MS attempts reselection to a UTRAN cell which is not suitable (see 3GPP TS 25.304) due to being part of the "list of forbidden LAs for roaming" or belonging to a PLMN which is not indicated as being equivalent to the registered PLMN, the MS may abandon further reselection attempts towards this UTRAN cell and all other cells on the same frequency, for a period of up to 20 min. If the MS has to perform cell selection, this limitation shall be removed. If the MS is redirected under GERAN control to a frequency for which the timer is running, any limitation on that frequency shall be removed.

In case the MS attempts reselection to a E-UTRAN cell which is not suitable (see 3GPP TS 36.304) due to being part of the "list of forbidden tracking areas for roaming" (see 3GPP TS 24.301), and if the MS has received the PCID to TA Mapping information element (see 3GPP TS 44.018 and 3GPP TS 44.060) for the frequency of the cell, it shall abandon further reselection attempts towards this E-UTRAN cell and any E-UTRAN cell which is known to belong to the same Tracking Area until the PCID to TA Mapping information changes in the serving cell or until cell reselection occurs. If the mobile station has not received the PCID to TA Mapping information element for the frequency of the cell, the MS may abandon further reselection attempts towards this E-UTRAN cell and all other cells on the same frequency, for a period of up to 20 min. If the MS has to perform cell selection, this limitation shall be removed. If the MS is redirected under GERAN control to a frequency for which the timer is running, any limitation on that frequency shall be removed.

In case the MS attempts reselection to a E-UTRAN cell which is not suitable (see 3GPP TS 36.304) due to belonging to a PLMN which is not indicated as being equivalent to the registered PLMN, the MS may abandon further reselection attempts towards this E-UTRAN cell and all other cells on the same frequency, for a period of up to 20 min. If the MS has to perform cell selection, this limitation shall be removed. If the MS is redirected under GERAN control to a frequency for which the timer is running, any limitation on that frequency shall be removed.

The MS shall store the UTRAN cell RSCP suitability criterion parameters specified in sub-clause 6.6.5, whenever decoded from a UTRAN FDD cell of a PLMN in the stored list of equivalent PLMNs (see 3GPP TS 24.008) while attempting to reselect to a UTRAN FDD cell as part of the priority-based reselection algorithm. Stored RSCP suitability criteria shall not be used to evaluate the suitability of a UTRAN cell when evaluating a cell for reselection using the priority-based reselection algorithm.

6.6.7 Cell selection and re-selection to CSG cells and hybrid cells

6.6.7.1 Cell re-selection to CSG cells

If a mobile station is a member of at least one Closed Subscriber Group, i.e. at least one CSG ID and its PLMN ID is included in the MS's CSG Whitelist, then, in addition to normal cell reselection, the MS shall use an autonomous search function to detect UTRAN and/or E-UTRAN CSG cells. The autonomous search function shall at least detect previously visited allowed CSG cells.

NOTE 1: The autonomous search function is implementation dependent and controls when and/or where to search for allowed CSG cells.

NOTE 1a: (void).

NOTE 2: (void).

NOTE 3: (void).

If the strongest cell (see 3GPP TS 25.304 and 3GPP TS 36.304 for the definition of the strongest cell) which the MS has detected on a UTRAN or E-UTRAN frequency during a time interval $T_{\text{reselection}}$ is a suitable CSG cell (see 3GPP TS 25.304 and 3GPP TS 36.304 for suitability criteria for UTRAN and E-UTRAN CSG cells respectively), the MS shall reselect to this cell irrespective of the cell reselection rules applicable for the cell on which the MS is currently camped.

The following requirements are valid for reselection to allowed CSG cells previously visited by the MS when the radio configuration parameters, including the carrier frequency and PSC/PCI (whichever and if it is applicable) of the CSG cell, non CSG cell and other neighbour cells, are unchanged from the most recent previous visit. The autonomous search and cell re-selection to a previously visited allowed CSG cell shall meet the performance requirements defined as follows:

- the MS shall perform search and re-selection to a previously visited allowed UTRAN FDD CSG cell, that has met the CSG cell re-selection criterion defined above, within 6 minutes in the radio conditions specified for an UTRAN FDD CSG cell in 3GPP TS 36.133 in terms of parameters for CSG inter-RAT UTRAN FDD reselection; UARFCN and PSC shall be unchanged from the most recent previous visit of the UTRAN FDD CSG cell; Serving GSM cell at $RXLEV = -70$ dBm, with 6 GSM neighbours at $RXLEV = -75$ dBm;
- the MS shall perform search and re-selection to a previously visited allowed E-UTRAN CSG cell, that has met the CSG cell re-selection criterion defined above, within 6 minutes in the radio conditions specified for an E-UTRAN CSG cell in 3GPP TS 25.133 in terms of parameters for CSG inter-RAT E-UTRA reselection; E-UARFCN and PCI shall be unchanged from the most recent previous visit of the E-UTRAN CSG cell; Serving GSM cell at $RXLEV = -70$ dBm, with 6 GSM neighbours at $RXLEV = -75$ dBm.

NOTE 4: The above performance requirements are minimum requirements defined to ensure the testability of autonomous CSG search.

The MS shall disable the autonomous search function for CSG cells if the MS has no CSG Whitelist or the MS's CSG Whitelist is empty.

When the MS has no or an empty CSG Whitelist, and the MS has stored "CSG PSC Split Information" or "CSG PCI Split Information", the MS shall ignore for measurement and cell re-selection cells known to be CSG cells, i.e.:

- cells on a UTRAN frequency with PSC in the stored range "CSG PSC Split Information" for that frequency (see 3GPP TS 25.331);
- cells on an E-UTRAN frequency with PCI in the stored range "CSG PCI Split Information" for that frequency (see 3GPP TS 36.331).

In addition, when the MS has no or an empty CSG Whitelist, the MS may ignore for measurement and cell re-selection cells known to be CSG cells according to implementation specific means on a frequency for which no "CSG PCI Split Information" or "CSG PSC Split Information" is stored.

The network may provide information about dedicated UTRAN CSG frequencies and/or dedicated E-UTRAN CSG frequencies. In this case, the MS may use the autonomous search function only on these dedicated frequencies and on the other frequencies listed in the system information. When the MS has no or an empty CSG Whitelist, the MS shall ignore those frequencies for measurement and cell re-selection.

A mobile station which has an "Allowed CSG list" which is not empty shall not use stored RSCP parameters to evaluate a candidate UTRAN FDD CSG cell for reselection, unless those (stored) parameters were obtained from a CSG cell with the same physical layer identifiers (frequency and PSC).

The mobile station which has an "Allowed CSG list" which is not empty may store the UTRAN cell RSCP suitability criterion parameters from a UTRAN FDD CSG cell; in this case, these stored parameters shall be stored separately from parameters stored as specified in sub-clauses 6.6.5 and 6.6.6 and may only be used subsequently to evaluate a candidate CSG cell with the same physical layer identifiers.

6.6.7.1a Cell re-selection to hybrid cells

If a mobile station is a member of at least one Closed Subscriber Group then, in addition to normal cell reselection, the MS shall use an autonomous search function to detect hybrid cells. The autonomous search function shall at least detect previously visited hybrid cells whose CSG IDs are included in the CSG Whitelist of the MS.

NOTE: The autonomous search for hybrid cells does not imply that the MS needs to constantly check the CSG IDs of all cells it sees, and the impact on battery consumption should be minimised.

If a neighbour cell has been detected as a hybrid cell and the CSG ID of the hybrid cell is included in the CSG Whitelist of the MS, reselection to that cell shall follow the rules for CSG cells in subclause 6.6.7.1. Otherwise normal cell reselection rules (see subclause 6.6.5 and 6.6.6) shall apply.

6.6.7.2 Manual CSG ID selection

If NAS requests AS to search for available CSG IDs, the MS shall perform the search and report the results to NAS as described in 3GPP TS 25.304 for UTRAN and as described in 3GPP TS 36.304 for E-UTRAN.

If a CSG ID is manually selected by NAS, the MS shall behave as specified in 3GPP TS 25.304 or in 3GPP TS 36.304, depending on the RAT type of the selected CSG cell.

6.7 Release of TCH, SDCCH and DBPSCH

6.7.1 Normal case

In *A/Gb mode*, when the MS releases all TCHs or SDCCH and returns to idle mode, packet idle mode or MAC-Idle state, it shall, as quickly as possible, camp on the cell whose channel has just been released. Similarly in *Iu mode*, when the MS releases all DBPSCHs and returns to MAC-Idle state, it shall, as quickly as possible, camp on the cell whose channel has just been released. However, in both modes (*A/Gb mode* or *Iu mode*), if the CHANNEL RELEASE message contains a “cell selection indicator after release of all TCH and SDCCH” (see TS 44.018), the MS shall as quickly as possible camp on an indicated GSM, UTRAN or E-UTRAN cell that has been identified by the CHANNEL RELEASE message. If UTRAN or E-UTRAN frequency only is indicated the MS shall as quickly as possible camp on a suitable cell of this frequency.

In case the “cell selection indicator after release of all TCHs and SDCCH” is not present, then if the full (P)BCCH data for that cell was not decoded in the preceding 30s, the MS shall attempt to decode the full (P)BCCH data. Until the MS has decoded the (P)BCCH data required for determining the paging group, it shall also monitor all paging blocks on timeslot 0 of the BCCH carrier or, for GPRS if PCCCH exists and for *Iu mode*, on the PDCH indicated on BCCH for possible paging messages that might address it. If the MS receives a page before having decoded the full (P)BCCH data for the cell, the MS shall store the page and respond once the relevant (P)BCCH data has been decoded, provided that the cell is not barred and the MS's access class is allowed. Reception of full BCCH(BA) information is not required before responding to the page.

If the CHANNEL RELEASE does not contain a “cell selection indicator after release of all TCH and SDCCH”, and the MS has the knowledge that the cell whose channel is being released is not suitable (see 3GPP TS 43.022), the MS is allowed to camp on any suitable cell.

If the CHANNEL RELEASE contains a “cell selection indicator after release of all TCH and SDCCH” and

- the MS cannot find a suitable cell from the indicated ones within 10 s, or
- none of the indicated cells are suitable,

the MS is allowed to camp on any suitable cell.

NOTE: The received signal level measurements on surrounding cells made during the last 5 seconds on the TCH or SDCCH in *A/Gb mode*, or on the DBPSCH in *Iu mode*, may be averaged and used, where possible, to speed up the process. However, it should be noted that the received signal level monitoring while on the TCH or SDCCH in *A/Gb mode*, or on the DBPSCH in *Iu mode*, is on carriers in BA (SACCH), while the carriers to be monitored for cell reselection are in BA (BCCH) or BA (GPRS).

After decoding the relevant (P)BCCH data the MS shall perform cell reselection as specified in 3GPP TS 43.022.

6.7.2 Call re-establishment

In the event of a radio link failure, call re-establishment may be attempted on a GSM cell (according to the procedure in 3GPP TS 44.018). The MS shall perform the following algorithm to determine which cell to use for the call re-establishment attempt.

- i) The received signal level measurement samples taken on the carriers indicated in the BA (SACCH) received on the serving cell and on the serving cell BCCH carrier in the last 5 seconds shall be averaged, and the carrier with the highest average received signal level with a permitted NCC as indicated on the SACCH of the serving cell (see subclause 7.2) shall be taken.
- ii) On this carrier the MS shall attempt to decode the BCCH data block containing the parameters affecting cell selection.
- iii) If the cell is suitable (see 3GPP TS 43.022) and call re-establishment is allowed, call re-establishment shall be attempted on this cell.
- iv) If the MS is unable to decode the BCCH data block or if the conditions in iii) are not met, the carrier with the next highest average received signal level with a permitted NCC shall be taken, and the MS shall repeat steps ii) and iii) above.
- v) If the cells with the 6 strongest average received signal level values with a permitted NCC have been tried but cannot be used, the call re-establishment attempt shall be abandoned, and the algorithm of subclause 6.7.1 shall be performed.

The MS is under no circumstances allowed to access a cell to attempt call re-establishment later than 20 seconds after the detection within the MS of the radio link failure causing the call re-establishment attempt. In the case where the 20 seconds elapses without a successful call re-establishment the call re-establishment attempt shall be abandoned, and the algorithm of subclause 6.7.1 shall be performed.

Call re-establishment shall not be applied for voice group calls.

6.8 Abnormal cases and emergency calls

When in the limited service state (see 3GPP TS 43.022) the aim is to gain normal service rapidly and the following tasks shall be performed, depending on the conditions, as given in the table below:

- a) The MS shall monitor the received signal level of all RF channels within its bands of operation, and search for a BCCH carrier which has $C1 > 0$ and which is not barred. When such a carrier is found, the MS shall camp on that cell, irrespective of the PLMN identity.
- b) The MS shall search the strongest RF channels to determine which PLMNs are available (Manual Mode) or available and allowable (Automatic Mode). This information shall be processed according to the PLMN selection algorithm defined in 3GPP TS 43.022.
- c) The MS shall perform cell reselection at least among the cells of the PLMN of the cell on which the MS has camped, according to the algorithm of 3GPP TS 43.022, except that a zero value of CELL_RESELECT_HYSTERESIS shall be used.

Condition			Tasks to be performed as a minimum:		
SIM Present	Other	MS camped on a cell	a)	b)	c)
X	X	No	Yes	No	No
No	X	Yes	No	No	Yes
Yes	"IMSI Unknown", "illegal MS"	Yes	No	No	Yes
Yes	No suitable cell of selected PLMN or "PLMN not allowed"	Yes	No	Yes	Yes

NOTE: X = "Don't care state".

In this state, the only services available to the mobile station are:

- i) the establishment of emergency calls (which may only be made if task c) was being performed).
- ii) the reception of warning notifications in the conditions where the mobile station is able to receive paging as specified in 3GPP TS 23.122.

Powering down of the MS is permitted.

7 Network pre-requisites

7.1 BCCH carriers

The BCCH carrier shall be continuously transmitted on all timeslots.

It shall be transmitted without variation of RF level in case all timeslots on BCCH carrier are GMSK modulated and else in case of different modulated timeslots with minimum variation of RF level as specified below.

The RF power level may be ramped down between timeslots for instance to facilitate switching between RF transmitters.

A BTS that is switching transmission between two or more antennas, shall use the same antenna for transmission on a CCCH slot and the slot immediately preceding the CCCH slot (i.e. antenna switching shall be avoided immediately before a CCCH slot in order to avoid unpredictable path loss changes at this point).

For timeslots on the BCCH carrier which are transmitted with modulations other than GMSK, the output power (as defined in 3GPP TS 45.005) may be lower than the output power used for GMSK modulated timeslots. In this case, the maximum allowed difference in output power actually transmitted by the BTS is listed for each respective modulation of EGPRS, EGPRS2 and VAMOS in the table below. Furthermore, between a slot used for BCCH/CCCH and the slot preceding it, the difference in output power actually transmitted by the BTS shall not exceed 3 dB.

NOTE: The allowed output power decrease does not refer to a difference between nominal power levels, but to the difference in output power actually transmitted.

	Modulation	Output Power Decrease
EGPRS	8PSK	4 dB
EGPRS2-A	16QAM	6 dB
EGPRS2-A	32QAM	6 dB
EGPRS2-B	QPSK	4 dB
EGPRS2-B	16QAM	6 dB
EGPRS2-B	32QAM	6 dB
VAMOS	AQPSK	4 dB

The MS requirements on signal strength measurements are defined for the case when only GMSK modulation is used on the BCCH carrier. There are no defined signal strength measurement requirements for the MS if other modulations are used on the BCCH carrier.

On the PCH the network shall send valid layer 3 messages according to 3GPP TS 44.018. Unused signalling blocks on the CCCH/BCCH shall contain L2 fill frames. Other unused timeslots shall transmit dummy bursts.

The number of neighbour cell BCCH carriers in the BCCH allocation shall not exceed 32.

NOTE 1: This BCCH organization enables MS to measure the received signal level from surrounding cells by tuning and listening to their BCCH carriers. Providing that an MS tunes to the list of BCCH carriers indicated by the network it will, providing the list is sufficiently complete, have listened to all possible surrounding cells, i.e. the surrounding cell list for handover purposes is effectively defined by the MS. Refer to 3GPP TS 43.022 for definitions of the BCCH carrier lists. This can be achieved without inter-base station synchronization.

NOTE 2: If the operator decides to allow for the usage of modulation types other than GMSK on the BCCH carrier in certain cells, the cell selection, cell reselection and handover procedures involving these cells will be somewhat sub-optimal. This is due to the fact that the signal level measured by the MS at some instances in time will be affected by the possibly lower output power level of the 8-PSK modulation type used in EGPRS, and by the output power level of QPSK, 8-PSK, 16-QAM and 32-QAM modulation types used in EGPRS2, and by the AQPSK modulation used in VAMOS respectively, and by the power fluctuation resulting from these modulation types other than GMSK. The extent of the performance degradation is dependent upon the measurement schedule in each particular MS as well as upon the used output power decrease and the current load of the modulation types other than GMSK on the BCCH carrier. By limiting the maximum number of time slots, carrying modulation types other than GMSK, being simultaneously allowed on the BCCH carrier, and/or carefully selecting the values of involved network parameters, the impact on the above mentioned procedures may be minimised. Additionally, in areas with very low cell overlap, some coverage loss effects may have to be taken into account by the operator when selecting network parameters.

NOTE 3: In the case that QPSK, AQPSK, 8-PSK, 16-QAM or 32-QAM modulation s (see Note 2) are allowed on the BCCH carrier and frequency hopping including the BCCH carrier is used, the reception quality in connected mode for some fast moving MS (meaning MS experiencing Doppler frequencies of 100 Hz or more) may be degraded. This may be seen as a backwards compatibility problem for some existing MS, most likely occurring if the used APD is larger than 2 dB.

7.2 Identification of surrounding BSS for handover measurements

It is essential for the MS to identify which surrounding BSS is being measured in order to ensure reliable handover. Because of frequency re-use with small cluster sizes, the BCCH carrier frequency may not be sufficient to uniquely identify a surrounding cell, i.e. the cell in which the MS is situated may have more than one surrounding cell using the same BCCH frequency. Thus it is necessary for the MS to synchronize to and demodulate surrounding BCCH carriers and identify the base station identification code (BSIC). The MS shall be able to perform this task at levels down to the reference sensitivity level or reference interference levels as specified in 3GPP TS 45.005.

The MS shall use at least 4 spare frames per SACCH block period for the purpose of decoding the BSICs (e.g. in the case of TCH/F, the four idle frames per SACCH block period). These frames are termed "search" frames.

A 6 bit Base Station Identity Code (BSIC), as defined in 3GPP TS 23.003, shall be transmitted on each BCCH carrier. The PLMN part of the BSIC can be regarded as a "PLMN colour code".

The MS shall attempt to demodulate the SCH on the BCCH carrier of as many surrounding cells as possible, and decode the BSIC as often as possible, and as a minimum at least once every 10 seconds. A multi-RAT MS is allowed to extend this period to 13 seconds, if the neighbour cell list contains cells or frequencies from other RATs. The MS shall give priority for synchronisation attempts in signal strength order and considering the parameter MULTIBAND_REPORTING. A list containing information about the timing of the surrounding cells at the accuracy required for accessing a cell (see 3GPP TS 45.010) including the absolute times derived from the parameters T1, T2, T3 shall be kept by the MS. This information may be used to schedule the decoding of BSIC and shall be used in connection with handover in order to keep the switching time at a minimum. The network may provide Real Time Difference (RTD, see 3GPP TS 45.010) to assist the MS in neighbour cell synchronisation attempts. This assistance data is included in the MEASUREMENT INFORMATION message (See 3GPP TS 44.018). RTD is provided modulo one multiframe (51 TDMA frames). The resolution is either one TDMA frame, in which case the MS can assume that the cells are frame synchronised, or 1/64 TDMA frame. The MS may use other assistance data too, if received elsewhere, e.g. for position services received information. The actual number of carriers the MS is capable of synchronising to, depends on the Observed Time Difference (OTD, see 3GPP TS 45.010) for each neighbour cell and the availability of the assistance information.

If, after averaging measurement results over 2 SACCH block periods, the MS detects one or more BCCH carriers, among the 6 strongest, whose BSICs are not currently being assessed, then the MS shall as a matter of priority attempt to decode their BSICs.

In the case of a multi band MS, the MS shall attempt to decode the BSIC, if any BCCH carrier with unknown BSIC is detected among the number of strongest BCCH carriers in each band as indicated by the parameter MULTIBAND_REPORTING.

Thus an MS shall, for a period of up to 5 seconds, devote all search frames to attempting to decode these BSICs. If this fails then the MS shall return to confirming existing BSICs. Having re-confirmed existing BSICs, if there are still BCCH carriers, among the six strongest, with unknown BSICs, then the decoding of these shall again be given priority for a further period of up to 5 seconds.

The MS shall report a new strongest GSM cell in the measurement report at the latest 5 s after a new strongest cell (which is part of the BA(SACCH)) has been activated under the following network conditions: Initial serving cell at RXLEV= -70 dBm, with 6 neighbours at RXLEV= -75 dBm. Then the new BCCH carrier is switched on at RXLEV= -60 dBm.

NOTE: Because of test equipment limitations it is acceptable to activate the new carrier to replace one of the 6 neighbours.

If either no BSIC can be demodulated on a surrounding cell BCCH carrier, or the BSIC is not allowed, then the received signal level measurements on that channel shall be discarded. The allowed BSIC is either the BSIC broadcast for that carrier in the neighbour cell list or, if no BSIC is included or if indicated by the parameter INVALID_BSIC_REPORTING, a BSIC with permitted NCC part. The permitted NCCs are defined by the NCC_PERMITTED parameter transmitted in the BCCH data. This is an 8 bit map that relates to the NCC part of BSIC (e.g. NCC_PERMITTED = 01101001, defines that only carriers having a BSIC with the NCC part = 000, 011, 101, 110 shall be reported). In a shared cell, the MS supporting Network sharing (see 3GPP TS 44.018 [17], 3GPP TS 23.251 [45] and 3GPP TS 24.008 [46]) shall use the NCC_PERMITTED applicable for the selected PLMN.

If a change of BSIC is detected on a carrier, then any existing received signal level measurement shall be discarded and a new averaging period commenced. This occurs when the MS moves away from one surrounding cell and closer to another co-channel cell.

If the BSIC cannot be decoded at the next available opportunities re-attempts shall be made to decode this BSIC. If the BSIC is not decoded for more than three successive attempts it will be considered lost and any existing received signal level measurement shall be discarded.

If an MS receives a handover command towards a GSM cell to which it is not synchronised to, then the MS shall search for synchronisation information up to 300 ms. In case of failure, the MS shall refer to the handover failure procedure (see 3GPP TS 44.018).

If a multi-RAT MS receives a handover command towards a not known cell (see 3GPP TS 25.133 and 3GPP TS 25.123 for UTRAN), then the multi-RAT MS shall search for synchronisation information up to 800 ms. In case of failure, the multi-RAT MS shall refer to the handover failure procedure (see 3GPP TS 44.018).

Details of the synchronization mechanisms appear in 3GPP TS 45.010. The procedure for monitoring surrounding BTS with respect to HO measurement shall begin at least at the time of assignment of a dedicated channel.

When a BCCH carrier is found to be no longer among the reported, timing and BSIC information shall be retained for at least 10 seconds. (This is in case a handover is commanded to this cell just after the MS stops reporting RXLEV and RXQUAL on this cell).

7.3 Handover measurements on other radio access technologies

For a multi-RAT MS, the network controls the identification and measurements of UTRAN and CDMA2000 cells by the parameter Qsearch_C sent on SACCH or, if Qsearch_C is not received, by Qsearch_C_Initial sent on BCCH. Qsearch_C defines a threshold and also indicates whether these tasks shall be performed when RXLEV (see subclause 8.1.3) of the serving BCCH carrier is below or above the threshold.

If the serving cell is not included in the BA(SACCH) list, the dedicated channel is not on the BCCH carrier, and Qsearch_C is not equal to 15, the MS shall disregard the Qsearch_C parameter value and always search for UTRAN and CDMA2000 cells. If Qsearch_C is equal to 15, the MS shall never search for UTRAN or CDMA2000 cells.

For a UTRAN capable MS, the network enables the identification and measurement for UTRAN cells on specific frequencies by DEFAULT_Measurement_Control_UTRAN and Measurement_Control_UTRAN sent on SACCH.

For a E-UTRAN capable MS, the network controls the identification and measurements of E-UTRAN cells by the parameter Qsearch_C_E-UTRAN sent on SACCH or, if Qsearch_C_E-UTRAN is not received, by Qsearch_C_E-UTRAN_Initial sent on BCCH.

For a E-UTRAN capable MS, the network enables the identification and measurement for E-UTRAN cells on specific frequencies by DEFUALT_Measurement_Control_E-UTRAN and Measurement_Control_E-UTRAN sent on SACCH.

The MS may use the search frames, which are not required for BSIC decoding, for measurements of UTRAN, CDMA2000 and E-UTRAN cells. The MS may use up to 25 search frames per 13 seconds without considering the need for BSIC decoding in these frames.

A UTRAN capable MS shall report a new best UTRAN cell, which is part of the neighbour cell list, at the latest 5 seconds after it has been activated under the condition that there is only one UTRAN frequency in the neighbour cell list (and no E-UTRAN frequencies in the E-UTRAN Neighbour Cell list) and that no new GSM cells are activated at the same time and under good radio conditions. A E-UTRAN capable MS that supports measurement reporting in dedicated mode or dual transfer mode shall report a new best E-UTRAN cell, on a frequency contained in the neighbour cell list, at the latest 5 seconds after it has been activated under the condition that there is only one E-UTRAN frequency in the neighbour cell list (and no UTRAN frequencies in the 3G Neighbour Cell list) and that no new GSM cells are activated at the same time and under good radio conditions. For test purposes the following radio conditions can be used: Serving GSM cell at RXLEV= -70 dBm, with 6 GSM neighbours at RXLEV= -75 dBm. Then either an UTRAN FDD neighbour cell or an UTRAN TDD neighbour cell or an E-UTRAN FDD neighbour cell or an E-UTRAN TDD neighbour cell is switched on. The radio conditions for the UTRAN FDD cell are as follows (see 3GPP TS 25.101 for definitions):

Parameter	Unit	UTRAN FDD Cell
<i>CPICH_Ec/Ior</i>	dB	-10
<i>P-CCPCH_Ec/Ior</i>	dB	-12
<i>SCH_Ec/Ior</i>	dB	-12
<i>PICH_Ec/Ior</i>	dB	-15
<i>DPCH_Ec/Ior</i>	dB	$-\infty$
<i>OCNS_Ec/Ior</i>	dB	-0.94
\hat{I}_{or}/I_{oc}	dB	10
<i>I_{oc}</i>	dBm/3.84 MHz	-70
<i>CPICH_Ec/Io</i>	dB	-10.4
<i>CPICH RSCP</i>	dBm	-70
FDD_MULTIRAT_REPORTING	integer	1
Qsearch_C	integer	7 (search always)
Propagation Condition	AWGN	

The radio conditions for the UTRAN TDD cell (either 3.84 Mcps TDD option or 1.28 Mcps TDD option) are as follows (see 3GPP TS 25.123 for definitions and for the values of the remaining configuration parameters):

Parameter	Unit	UTRAN TDD Cell (3.84 Mcps option)	
<i>Timeslot Number</i>		0	8
<i>P-CCPCH_Ec/Ior</i>	dB	-3	
<i>SCH_Ec/Ior</i>	dB	-9	-9
<i>SCH_{t_offset}</i>	integer	0	0
<i>PICH_Ec/Ior</i>	dB		-3
<i>OCNS_Ec/Ior</i>	dB	-3.12	-3.12
<i>P-CCPCH RSCP</i>	dBm	-70	-70
TDD_MULTIRAT_REPORTING	integer	1	
Qsearch_C	integer	7 (search always)	
Propagation Condition	AWGN		

NOTE: On timeslot 8 the P-CCPCH is not transmitted; on that timeslot, the P-CCPCH RSCP defines the power level of the beacon channel.

Parameter	Unit	UTRAN TDD Cell (1.28 Mcps option)	
<i>Timeslot Number</i>		0	DwPTS
<i>P-CCPCH Ec/Ior</i>	dB	-3	
<i>DwPCH Ec/Ior</i>	dB		0
<i>OCNS Ec/Ior</i>	dB	-3	
<i>P-CCPCH RSCP</i>	dBm	-70	
TDD_MULTIRAT_ REPORTING	integer	1	
Qsearch_C	integer	7 (search always)	
Propagation Condition	AWGN		

The radio conditions for the E-UTRAN FDD cell are as follows (see 3GPP TS 36.101 for definitions):

Parameter	Unit	E-UTRAN FDD Cell
<i>Channel Bandwidth</i>	MHz	10
<i>PSS_RB, SSS_RB, PBCH_RA, PBCH_RB, PCFICH_RA, PHICH_RA, PHICH_RB, PDCCH_RA, PDCCH_RB, PDSCH_RA, PDSCH_RB</i>	dB	0
<i>OCNG_RA</i> (Note 1)	dB	0
<i>OCNG_RB</i> (Note 1)	dB	0
N_{oc}	dBm/15kHz	-98
\hat{E}_s/I_{ot}	dB	12
<i>RSRP</i>	dBm/15kHz	-86
<i>SCH_RP</i>	dBm	-86
Qsearch_C_E-UTRAN	integer	7 (search always)
E-UTRAN_MULTIRAT_ REPORTING	integer	1
OCNG pattern	OP.2 FDD (see 3GPP TS 36.133)	
MIMO configuration	single transmitter	
Propagation Condition	AWGN	
NOTE 1: OCNG shall be used such that the E-UTRAN cell is fully allocated and a constant total transmitted power spectral density is achieved for all OFDM symbols.		

The radio conditions for the E-UTRAN TDD cell are as follows (see 3GPP TS 36.101 for definitions):

Parameter	Unit	E-UTRAN TDD Cell
<i>Channel Bandwidth</i>	MHz	10
<i>PSS_RB, SSS_RB, PBCH_RA, PBCH_RB, PCFICH_RA, PHICH_RA, PHICH_RB, PDCCH_RA, PDCCH_RB, PDSCH_RA, PDSCH_RB</i>	dB	0
<i>OCNG_RA</i> (Note 1)	dB	0
<i>OCNG_RB</i> (Note 1)	dB	0
N_{oc}	dBm/15kHz	-98
\hat{E}_s/I_{ot}	dB	12
<i>RSRP</i>	dBm/15kHz	-86
<i>SCH_RP</i>	dBm	-86
Qsearch_C_E-UTRAN	integer	7 (search always)
E-UTRAN_MULTIRAT_REPORTING	integer	1
OCNG pattern	OP.2 TDD (see 3GPP TS 36.133)	
MIMO configuration	single transmitter	
Propagation Condition	AWGN	
NOTE 1: OCNG shall be used such that the E-UTRAN cell is fully allocated and a constant total transmitted power spectral density is achieved for all OFDM symbols.		

The allowed reporting time is increased by 5 seconds for each additional UTRAN frequency in the neighbour cell list or for each additional E-UTRAN frequency in the neighbour cell list and by the time required for BSIC decoding of new activated GSM cells. However, multiple UTRAN cells on the same frequency in the neighbour cell list does not increase the allowed reporting time.

When on TCH, identification of a UTRAN TDD cell is guaranteed only in case of single slot operation and, for the 3.84 Mcps option, if the UTRAN TDD cell uses synchronisation option 2 (see 3GPP TS 25.221). In all other cases, the MS may not be able to fulfil the requirement above. If after 5 seconds the MS has not been able to identify a UTRAN TDD cell, the MS is allowed to stop searching for it in the current GSM cell.

When on SDCCH, the MS may use all TDMA frames, which are not part of the assigned channel or required for GSM signal strength measurements, for the above task. In this case the allowed reporting time is 1.7 seconds, with the same assumptions as above.

A multi-RAT MS shall be able to monitor cells from other radio access technologies, divided into (depending on the MS capability):

- UTRAN FDD cells on up to 3 FDD frequencies, with a maximum of 32 cells per frequency
- UTRAN TDD cells on up to 3 TDD frequencies, with a maximum of 32 cells per frequency; and/or
- CDMA2000 cells; and/or
- E-UTRAN FDD cells on up to 3 FDD frequencies; and/or
- E-UTRAN TDD cells on up to 3 TDD frequencies.

The total number of monitored UTRAN and CDMA2000 cells shall not exceed 64.

The MS shall be capable of performing RSCP and E_c/N_o measurements of at least 4 best UTRAN cells per UTRAN frequency and RSRP and RSRQ measurements of at least 4 best E-UTRAN cells per E-UTRAN frequency, according to its supported capabilities.

A multi-RAT MS with no or an empty CSG Whitelist, or which does not indicate support of "UTRA CSG Cells Reporting" in the *Classmark 3 IE* (see 3GPP TS 24.008), is not required to measure, and shall not report, cells known to be CSG cells while in dedicated mode or dual transfer mode.

7.4 Handover measurements on UTRAN CSG cells and hybrid cells

A UTRAN capable mobile station supporting "UTRA CSG Cells Reporting" shall support MIB/SIB3 reading and reporting for UTRAN CSG cells in dedicated mode and dual transfer mode. The mobile station may acquire the routing parameters and CSG ID of a UTRAN CSG cell by reading MIB and SIB3 of that cell (see 3GPP TS 25.331). The MS is allowed to autonomously skip idle frames or TDMA frames on TCH and/or, in case of dual transfer mode, on PDCH to read MIB and SIB3 and only skips the timeslot(s) or TDMA frame(s) during which either MIB or SIB3 is transmitted.

A UTRAN capable mobile station which indicates support of "UTRA CSG Cells Reporting" in the *Classmark 3* IE (see 3GPP TS 24.008) shall report CSG cells and hybrid cells in dedicated mode and dual transfer mode according to the procedures in sub-clause 8.4.9 if:

- the cell is the strongest of any cell on the same frequency (see 3GPP TS 25.304 for the definition of the strongest cell); and
- (for UTRAN FDD CSG cells) the reported value (CPICH Ec/No) is equal to or higher than `UTRAN_CSG_FDD_REPORTING_THRESHOLD` and the non-reported value (CPICH RSCP) is equal to or higher than `UTRAN_CSG_FDD_REPORTING_THRESHOLD_2`; and
- (for UTRAN TDD CSG cells) the reported value (P-CCPCH RSCP) is equal to or higher than `UTRAN_CSG_TDD_REPORTING_THRESHOLD`; and
- the conditions specified in 3GPP TS 44.018 are met.

The parameters `Qsearch_C` and `Measurement_Control_UTRAN` are not applicable to UTRAN CSG cells.

If information about dedicated CSG frequencies is available to the MS, the MS may restrict the measurement of CSG cells to only those on these dedicated frequencies and the other frequencies listed in the system information.

8 Radio link measurements

Radio link measurements are used in the handover and RF power control processes.

In particular, radio-subsystem directed handover is defined as a change of channel(s) during a call either because of degradation of the quality of one or more of the current serving channel(s), or because of the availability of other channel(s) which can allow communication at a lower TX power level, or to prevent a MS grossly exceeding the planned cell boundaries.

Additional measurements, so called Extended measurements, can e.g. be used for frequency planning purposes.

The measurements are made over each SACCH multiframe, which is 104 TDMA frames (480 ms) for a TCH and DBPSCH, and 102 TDMA frames (470,8 ms) for an SDCCH. Additionally, when in FPC mode, quality measurements shall also be made over each FPC reporting period. Additionally, when in EPC mode, quality measurements shall also be made over each EPC reporting period.

For a multi-RAT MS, measurements on other radio access technologies may be performed during search frames (see subclause 7.3 and 10.1.1.3).

8.1 Signal level

8.1.1 General

The received signal level may be employed as a criterion in the RF power control and handover processes. For cells of other radio access technology, RXLEV is replaced by the relevant measurement quantity for that radio access technology (see subclause 8.1.5).

8.1.2 Physical parameter

The R.M.S received signal level at the receiver input shall be measured by the MS and the BSS over the full range of -110 dBm to -48 dBm with an absolute accuracy of ± 4 dB from -110 dBm to -70 dBm under normal conditions and ± 6 dB over the full range under both normal and extreme conditions. The R.M.S received signal level at the receiver input shall be measured by the MS above -48 dBm up to -38 dBm with an absolute accuracy of ± 9 dB under both normal and extreme conditions.

If the received signal level falls below the reference sensitivity level for the type of MS or BSS, then the measured level shall be within the range allowing for the absolute accuracy specified above. In case the upper limit of this range is below the reference sensitivity level for the type of MS or BSS, then the upper limit shall be considered as equal to the reference sensitivity level.

The relative accuracy shall be as follows:

If signals of level x_1 and x_2 dBm are received (where $x_1 \leq x_2$) and levels y_1 and y_2 dBm respectively are measured, if $x_2 - x_1 < 20$ dB and x_1 is not below the reference sensitivity level, then y_1 and y_2 shall be such that:

$(x_2 - x_1) - a \leq y_2 - y_1 \leq (x_2 - x_1 + b)$ if the measurements are on the same or on different RF channel within the same frequency band;

and

$(x_2 - x_1) - c \leq y_2 - y_1 \leq (x_2 - x_1 + d)$ if the measurements are on different frequency bands:

a , b , c and d are in dB and depend on the value of x_1 as follows:

	a	b	c	d
$x_1 \geq s+14, x_2 < -48$ dBm	2	2	4	4
$s+14 > x_1 \geq s+1$	3	2	5	4
$s+1 > x_1$	4	2	6	4

For single band MS or BTS and measurements between ARFN in the same band for a multiband MS or BTS;

s = reference sensitivity level as specified in 3GPP TS 45.005.

For measurements between ARFCN in different bands;

s = the reference sensitivity level as specified in 3GPP TS 45.005 for the band including x_1 .

At extreme temperature conditions an extra 2 dB shall be added to c and d in above table.

The selectivity of the received signal level measurement shall be as follows:

- for adjacent (200 kHz) channel ≥ 16 dB;
- for adjacent (400 kHz) channel ≥ 48 dB;
- for adjacent (600 kHz) channel ≥ 56 dB.

The selectivity shall be met using random, continuous, GSM-modulated signals with the wanted signal at the level 20 dB above the reference sensitivity level.

8.1.3 Statistical parameters

For each channel, the measured parameters (RXLEV) shall be the average of the received signal level measurement samples in dBm taken on that channel within the reporting period of length one SACCH multiframe defined in 8.4. In averaging, measurements made during previous reporting periods shall always be discarded.

When assigned a TCH or SDCCH in *A/Gb mode*, or a DBPSCH in *Iu mode*, the MS shall make a received signal level measurement:

- in every TDMA frame on at least one of the BCCH carriers indicated in the BCCH allocation (BA), one after another. Optionally, measurements during up to 8 frames per SACCH multiframe may be omitted;

As an exception, a multi-RAT MS may omit GSM measurements during up to 9 TDMA frames per SACCH multiframe and use these periods for measurements on other radio access technologies.

Furthermore, an MS on SDCCH is allowed schedule the measurements freely within the SACCH multiframe as long as the total number of measurement samples is maintained and the samples on each carrier are evenly spaced.

NOTE: These eight frames are the search frames and the frames immediately preceding the search frames, in order to allow the MS to search for BCCH synchronization (or inter-RAT measurements) over a full TDMA frame.

- for each assigned bi-directional channel, on all bursts of the associated physical channel (see 3GPP TS 45.002), including those of the SACCH. If frequency hopping is being used on the associated physical channel and if, in the BCCH Cell Options, the Power Control Indicator PWRC is set, measurements on the bursts on the BCCH frequency shall not be used in the RXLEV averaging process.

Unless otherwise specified by the operator, for any TCH or SDCCH assigned to an MS in *A/Gb mode*, or for any DBPSCH assigned to an MS in *Iu mode*, the BSS shall make a received signal level measurement on all time slots of the associated physical channel including those of the SACCH, but excluding the idle timeslots.

8.1.4 Range of parameter

The measured signal level shall be mapped to an RXLEV value between 0 and 63, as follows:

RXLEV	0	=	less than	-110 dBm + SCALE.
RXLEV	1	=	-110 dBm + SCALE	to -109 dBm + SCALE.
RXLEV	2	=	-109 dBm + SCALE	to -108 dBm + SCALE.
	:			
	:			
RXLEV	62	=	-49 dBm + SCALE	to -48 dBm + SCALE.
RXLEV	63	=	greater than	-48 dBm + SCALE.

where SCALE is an offset that is used in the ENHANCED MEASUREMENT REPORT and PACKET ENHANCED MEASUREMENT REPORT messages, otherwise it is set to 0.

The MS shall use the SCALE value as indicated by the parameter SCALE_ORD in the MEASUREMENT INFORMATION, PACKET CELL CHANGE ORDER and PACKET MEASUREMENT ORDER messages (see 3GPP TS 44.018 and 3GPP TS 44.060). If automatic scaling mode is indicated by SCALE_ORD, the MS shall choose the lowest SCALE value that is sufficient for reporting the strongest signal level within each ENHANCED MEASUREMENT REPORT or PACKET ENHANCED MEASUREMENT REPORT message.

The MS shall indicate the used SCALE value in each individual ENHANCED MEASUREMENT REPORT or PACKET ENHANCED MEASUREMENT REPORT message (see 3GPP TS 44.018 and 3GPP TS 44.060).

8.1.5 Measurement quantity for other radio access technologies

8.1.5.1 UTRAN FDD

For UTRAN FDD cells, the measurement quantities to be used are CPICH Ec/No and CPICH RSCP and RSSI. The measurement requirements are defined in 3GPP TS 25.133.

RSCP shall be used for the cell re-selection criteria. Ec/No and RSCP shall be used for a minimum quality requirement. Either RSCP or Ec/No shall be used for measurement reporting as indicated by the parameter

FDD_REP_QUANT, sent on BCCH, SACCH, PBCCH and PACCH. In addition, if a frequency without scrambling code is included in the neighbour cell list, RSSI shall be reported for that frequency.

The measured value shall replace RXLEV in the measurement reports. The mapping is defined in 3GPP TS 25.133. For RSCP, the range from “ $-116 \text{ dBm} \leq \text{CPICH RSCP} < -115 \text{ dBm}$ ” (reported as 0) to “ $-53 \text{ dBm} \leq \text{CPICH RSCP} < -52 \text{ dBm}$ ” (reported as 63) is used. RSCP values below -116 dBm shall be reported as 0 and values -52 dBm and above shall be reported as 63. For RSSI, the range from “ $-100 \text{ dBm} \leq \text{UTRA carrier RSSI} < -99 \text{ dBm}$ ” (reported as 1) to “ $-38 \text{ dBm} \leq \text{UTRA carrier RSSI} < -37 \text{ dBm}$ ” (reported as 63) is used. RSSI values below -100 dBm shall be reported as 0 and values -37 dBm and above shall be reported as 63. For Ec/No, the range from “ $-24 \text{ dB} \leq \text{CPICH Ec/Io} < -23.5 \text{ dB}$ ” (reported as 1) to “ $-0.5 \text{ dB} \leq \text{CPICH Ec/Io} < 0 \text{ dB}$ ” (reported as 48) is used. Ec/No values below -24 dB shall be reported as 0 and values 0 dB and above shall be reported as 49.

8.1.5.2 UTRAN TDD

For UTRAN TDD cells, the measurement quantity to be used is P-CCPCH RSCP. The measurement requirements are defined in 3GPP TS 25.123.

NOTE: The RSCP may alternatively be measured on any beacon channel (see 3GPP TS 25.221).

The measured value shall replace RXLEV in the measurement reports. The mapping is defined in 3GPP TS 25.123. For RSCP, the range from “ $116 \text{ dBm} \leq \text{P-CCPCH RSCP} < -115 \text{ dBm}$ ” (reported as 0) to “ $-53 \text{ dBm} \leq \text{P-CCPCH RSCP} < -52 \text{ dBm}$ ” (reported as 63) is used. Values below -116 dBm shall be reported as 0 and values -52 dBm and above shall be reported as 63.

8.1.5.3 cdma2000

For cdma2000 cells, the measurement quantity to be used is PILOT_STRENGTH of the pilot. The measurement requirements are defined in TIA/EIA/IS-2000-5-A.

The measured value shall replace RXLEV in the measurement reports.

8.1.5.4 E-UTRAN FDD

For E-UTRAN FDD cells, the measurement quantities to be used are RSRP and RSRQ. The measurement requirements are defined in 3GPP TS 36.133.

RSRP shall be used for the priority-based cell re-selection criteria. RSRQ may be used for the priority-based cell re-selection criteria and shall be used for link quality determination for handover purposes. Either RSRP or RSRQ shall be used for measurement reporting as indicated by the parameter E-UTRAN_REP_QUANT, sent on BCCH, SACCH and PACCH. An MS indicating support for E-UTRA Wideband RSRQ measurements (see 3GPP TS 24.008), shall perform these measurements on the number of resource blocks as indicated by the parameter Measurement Bandwidth (see 3GPP TS 44.018 and 3GPP TS 44.060), sent on BCCH, SACCH and PACCH.

The measured value shall replace RXLEV in the measurement reports. For reporting using 6 bits, the measured RSRP shall be mapped to a value between 0 and 63, as follows:

RSRP	0	=	less than	-140 dBm
RSRP	1	=	-140 dBm	to -138 dBm
	:			
	:			
RSRP	17	=	-108 dBm	to -106 dBm
RSRP	18	=	-106 dBm	to -105 dBm
RSRP	19	=	-105 dBm	to -104 dBm
	:			
	:			
RSRP	44	=	-80 dBm	to -79 dBm
RSRP	45	=	-79 dBm	to -78 dBm
RSRP	46	=	-78 dBm	to -76 dBm
	:			
	:			
RSRP	62	=	-46 dBm	to -44 dBm
RSRP	63	=	greater than or equal to	-44 dBm

NOTE 1: The mapping for RSRP is different from the one defined in 3GPP TS 36.133.

NOTE 2: For each reporting range, the lowest value of the interval is included whereas the highest value of the interval is excluded.

For reporting using 3 bits (see 3GPP TS 44.018), the measured RSRP shall be mapped to a value between 0 and 7 as follows, where ‘Offset’ is the value of the parameter E-UTRAN_FDD_MEASUREMENT_REPORT_OFFSET or E-UTRAN_TDD_MEASUREMENT_REPORT_OFFSET and ‘Step’ is the value given by the parameter REPORTING_GRANULARITY:

RSRP	0	=	Offset	to	Offset + Step
RSRP	1	=	Offset + Step	to	Offset + 2 * Step
RSRP	2	=	Offset + 2 * Step	to	Offset + 3 * Step
RSRP	3	=	Offset + 3 * Step	to	Offset + 4 * Step
RSRP	4	=	Offset + 4 * Step	to	Offset + 5 * Step
RSRP	5	=	Offset + 5 * Step	to	Offset + 6 * Step
RSRP	6	=	Offset + 6 * Step	to	Offset + 7 * Step
RSRP	7	=	greater than or equal to	to	Offset + 7 * Step

NOTE 3: For each reporting range, the lowest value of the interval is included whereas the highest value of the interval is excluded.

For RSRQ, the mapping is defined in 3GPP TS 36.133. For reporting using 6 bits, the range from “-19.5 dB ≤ RSRQ < -19 dB” (reported as 1) to “-3.5 dB ≤ RSRQ < -3 dB” (reported as 33) is used. RSRQ values below -19.5 dB shall be reported as 0 and values -3 dB and above shall be reported as 34.

In case of reporting using 3 bits (see 3GPP TS 44.018), the measured RSRQ shall be mapped to a value between 0 and 7 as follows, where ‘Offset’ is the value of the parameter E-UTRAN_FDD_MEASUREMENT_REPORT_OFFSET or E-UTRAN_TDD_MEASUREMENT_REPORT_OFFSET and ‘Step’ is the value given by the parameter REPORTING_GRANULARITY:

RSRQ	0	=	Offset	to	Offset + Step
RSRQ	1	=	Offset + Step	to	Offset + 2 * Step
RSRQ	2	=	Offset + 2 * Step	to	Offset + 3 * Step
RSRQ	3	=	Offset + 3 * Step	to	Offset + 4 * Step
RSRQ	4	=	Offset + 4 * Step	to	Offset + 5 * Step
RSRQ	5	=	Offset + 5 * Step	to	Offset + 6 * Step
RSRQ	6	=	Offset + 6 * Step	to	Offset + 7 * Step
RSRQ	7	=	greater than or equal to	to	Offset + 7 * Step

NOTE 4: For each reporting range, the lowest value of the interval is included whereas the highest value of the interval is excluded.

8.1.5.5 E-UTRAN TDD

For E-UTRAN TDD cells, the measurement quantities and their mappings are the same as for E-UTRAN FDD cells (see subclause 8.1.5.4).

8.2 Signal quality

8.2.1 General

The received signal quality shall be employed as a criterion in the RF power control and handover processes.

8.2.2 Physical parameter

The received signal quality shall be measured by the MS and BSS in a manner that can be related to an equivalent average BER before channel decoding (i.e. chip error ratio), assessed over the reporting period of 1 SACCH block.

For FPC, the received signal quality for each E-TCH shall be measured by the MS and BSS in a manner that can be related to the average BER before channel decoding, assessed over one FPC reporting period.

In *A/Gb mode*, for each TCH or O-TCH in EPC mode, the received signal quality shall be measured by the MS in a manner that can be related to the average BER before channel decoding, assessed over all received bursts, except bursts carrying a portion of a SACCH frame, during one EPC reporting period (as specified in subclause 8.4.1b). The MS shall include all bursts, irrespective of if downlink DTX was applied or not, when reporting EPC quality. The BSS implementation of uplink EPC quality measurements is left implementation dependent.

Similarly in *Iu mode*, for each DBPSCH in EPC mode, the received signal quality shall be measured by the MS in a manner that can be related to the average BER before channel decoding, assessed over all received bursts, except bursts carrying a portion of a SACCH frame, during one EPC reporting period (as specified in subclause 8.4.1b). The MS shall include all bursts, irrespective of if downlink DTX was applied or not, when reporting EPC quality. The BSS implementation of uplink EPC quality measurements is left implementation dependent.

For example, the measurement may be made as part of the channel equalization process, decoding process, pseudo-error rate measurement etc.

NOTE 1: Bursts carrying SACCH are excluded from the measurements in EPC mode, since the interleaving depth of the SACCH frame is longer than the EPC reporting period and the inclusion of SACCH therefore would preclude the use of pseudo-error rate measurements.

NOTE 2: Since all downlink bursts are measured by the MS, EPC quality reports that are affected by downlink DTX may not be correct.

For MEAN_BEP and CV_BEP reporting purposes, the received signal quality for each channel shall be measured on a burst-by-burst basis by the MS and BSS in a manner that can be related to the BEP (Bit Error Probability) for each burst before channel decoding using, for example, soft output from the receiver.

8.2.3 Statistical parameters

8.2.3.1 RXQUAL

For each channel, the measured parameters (RXQUAL) shall be the received signal quality, averaged on that channel over the reporting period of length one SACCH multiframe defined in subclause 8.4. In averaging, measurements made during previous reporting periods shall always be discarded.

Contrary to RXLEV measurements, in calculating RXQUAL values, measurements on bursts on the BCCH carrier shall always be included in the averaging process.

For E-TCH the average BER shall for every FPC reporting period be mapped to the RXQUAL scale according to chapter 8.2.4, producing the parameter RXQUAL_FAST which is reported to the network via E-IACCH.

In *A/Gb mode*, for each TCH or O-TCH in EPC mode, the average BER shall for every EPC reporting period be mapped to the RXQUAL scale according to chapter 8.2.4, producing the parameter RXQUAL_EPC. RXQUAL_EPC is reported to the network in an EPC Downlink Quality Report via EPCCH, as specified in subclause 8.4.1b.

Similarly in *Iu mode*, for each DBPSCH in EPC mode, the average BER shall for every EPC reporting period be mapped to the RXQUAL scale according to chapter 8.2.4, producing the parameter RXQUAL_EPC. RXQUAL_EPC is reported to the network in an EPC Downlink Quality Report via EPCCH, as specified in subclause 8.4.1b.

8.2.3.2 MEAN_BEP and CV_BEP

In *A/Gb mode*, for TCH, E-TCH, O-TCH, FACCH and O-FACCH, and in *Iu mode*, for TCH, E-TCH, O-TCH, FACCH, O-FACCH, PDTCH on DBPSCH, the MS shall calculate the mean bit error probability and the coefficient of variation of the bit error probability as defined below for the last 4 consecutive slots of each fully received and correctly decoded block (see subclause 8.4.8.2) and for all SDCCH and SACCH blocks. The coefficient of variation of the bit error probability is not calculated for SACCH/T blocks.

Note: The coefficient of variation of the bit error probability is of less interest in the SACCH/T case as the four SACCH bursts are non-consecutive.

For FLO in *Iu mode*, the MS shall calculate the mean bit error probability and the coefficient of variation of the bit error probability as defined below for the last 4 consecutive slots of each fully received and correctly decoded radio

packet on DBPSCH. When a radio packet is received with a TFC for which at least one transport channel that uses a CRC is active, the radio packet is considered as correctly decoded if at least one CRC is correct. When a radio packet is received with a TFC where no transport channel uses a CRC, the radio packet is always considered as correctly decoded.

- Mean Bit Error Probability (BEP) of the block:

$$MEAN_BEP_{block} = \frac{1}{4} \sum_{i=1}^4 BEP_{burst i}$$

- Coefficient of variation of the Bit Error Probability of the block:

$$CV_BEP_{block} = \frac{\sqrt{\frac{1}{3} \sum_{k=1}^4 \left(BEP_{burst k} - \frac{1}{4} \sum_{i=1}^4 BEP_{burst i} \right)^2}}{\frac{1}{4} \sum_{i=1}^4 BEP_{burst i}}$$

Note: The receiver needs to detect if a block (or radio packet in case of FLO) has been fully received (i.e. estimate whether it was fully transmitted) when DTX is used because a block (or radio packet in case of FLO) may be correctly decoded even if the last 4 slots were actually not transmitted, especially in the case of 19 interleaving.

The calculated values shall be averaged (on a linear scale) over the reporting period as follows:

MEAN_BEP = average of MEAN_BEP_{block}.

CV_BEP = average of CV_BEP_{block}.

In averaging, measurements made during previous reporting periods shall always be discarded.

For EGPRS, the MS shall calculate the following values for each radio block (4 bursts) addressed to it:

- Mean Bit Error Probability (BEP) of a radio block:

$$MEAN_BEP_{block} = \frac{1}{4} \sum_{i=1}^4 BEP_{burst i}$$

- Coefficient of variation of the Bit Error Probability of a radio block:

$$CV_BEP_{block} = \frac{\sqrt{\frac{1}{3} \sum_{k=1}^4 \left(BEP_{burst k} - \frac{1}{4} \sum_{i=1}^4 BEP_{burst i} \right)^2}}{\frac{1}{4} \sum_{i=1}^4 BEP_{burst i}}$$

Filtering and reporting are described in subclause 10.2.3.2.

8.2.4 Range of parameter RXQUAL

When the quality is assessed over the full-set and sub-set of frames defined in subclause 8.4, eight levels of RXQUAL are defined and shall be mapped to the equivalent BER before channel decoding as follows:

RXQUAL_0		BER < 0,2 %	Assumed value = 0,14 %
RXQUAL_1	0,2 %	< BER < 0,4 %	Assumed value = 0,28 %
RXQUAL_2	0,4 %	< BER < 0,8 %	Assumed value = 0,57 %
RXQUAL_3	0,8 %	< BER < 1,6 %	Assumed value = 1,13 %
RXQUAL_4	1,6 %	< BER < 3,2 %	Assumed value = 2,26 %
RXQUAL_5	3,2 %	< BER < 6,4 %	Assumed value = 4,53 %

RXQUAL_6	6,4 %	< BER	< 12,8 %	Assumed value = 9,05 %
RXQUAL_7	12,8 %	< BER		Assumed value = 18,10 %

The assumed values may be employed in any averaging process applied to RXQUAL.

The same mapping table applies also for RXQUAL_FAST and RXQUAL_EPC.

The BER values used to define a quality band are the estimated error probabilities before channel decoding, averaged over the full set or sub set of TDMA frames as defined in subclause 8.4. The accuracy to which an MS shall be capable of estimating the error probabilities under static channel conditions is given in the following table. Note the exceptions of subclause 8.4 on some data traffic channels and PDTCH.

Quality Band	Range of actual BER	Probability that the correct RXQUAL band is reported by MS shall exceed					
		Full rate Channel	Half rate Channel	DTX Mode	ECSD FPC mode	EPC on full rate channel	EPC on halfrate channel
RXQUAL_0	Less than 0,1 %	90 %	90 %	65 %	70 %	85 %	85 %
RXQUAL_1	0,26 % to 0,30 %	75 %	60 %	35 %	60 %	85 %	80 %
RXQUAL_2	0,51 % to 0,64 %	85 %	70 %	45 %	60 %	85 %	75 %
RXQUAL_3	1,0 % to 1,3 %	90 %	85 %	45 %	60 %	85 %	75 %
RXQUAL_4	1,9 % to 2,7 %	90 %	85 %	60 %	60 %	85 %	80 %
RXQUAL_5	3,8 % to 5,4 %	95 %	95 %	70 %	90 %	85 %	80 %
RXQUAL_6	7,6 % to 11,0 %	95 %	95 %	80 %	90 %	80 %	80 %
RXQUAL_7	Greater than 15,0 %	95 %	95 %	85 %	90 %	70 %	70 %

NOTE 1: For the full rate channel RXQUAL_FULL is based on 104 TDMA frames.
NOTE 2: For the half rate channel RXQUAL_FULL is based on 52 TDMA frames.
NOTE 3: For the DTX mode RXQUAL_SUB is based on 12 TDMA frames.
NOTE 4: For the ECSD FPC mode RXQUAL_FAST is based on 4 TDMA frames.
NOTE 5: For EPC on a full rate channel, RXQUAL_EPC is based on 26 TDMA frames.
NOTE 6: For EPC on a half rate channel, RXQUAL_EPC is based on 13 TDMA frames.
NOTE 7: For EPC on a full rate or half rate channel in DTX mode, no accuracy requirements are defined.

The accuracy to which an MS shall be capable of estimating the error probabilities under TU50 channel conditions is given in the following table. Note the exception of subclause 8.4 on data channels using interleaving depth 19, on half rate speech channel, and on PDTCH.

Range of actual BER	Expected RXQUAL_FULL	Probability that expected RXQUAL_FULL is reported shall exceed
Less than 0,1 %	RXQUAL_0/1	85 %
0,26 % to 0,30 %	RXQUAL_1/0/2	85 %
0,51 % to 0,64 %	RXQUAL_2/1/3	85 %
1,0 % to 1,3 %	RXQUAL_3/2/4	75 %
1,9 % to 2,7 %	RXQUAL_4/3/5	75 %
3,8 % to 5,4 %	RXQUAL_5/4/6	90 %
7,6 % to 11,0 %	RXQUAL_6/5/7	90 %
Greater than 15,0 %	RXQUAL_7/6	90 %

For channels operating in VAMOS mode, the same RXQUAL accuracy requirements as for channels in non-VAMOS mode shall apply. The requirements for VAMOS mode shall apply for values of SCPIR from -4 dB to +4 dB for mobile stations indicating support of VAMOS-I and for values of SCPIR from -10 dB to +10 dB for mobile stations indicating support of VAMOS-II (see 3GPP TS 24.008).

It should be noted that in the testing, the System Simulator (SS) or (BSSTE) Base Station System Test Equipment will have to measure the average error rate over a large number of TDMA frames.

8.2.5 Range of parameters MEAN_BEP and CV_BEP

The mapping of the MEAN_BEP to the equivalent BEP and the accuracies to which an MS shall be capable of estimating the quality parameters under static channel conditions are given in the following tables for GMSK, 8-PSK and AQPSK respectively. The accuracy requirements below apply for sensitivity limited operation for signal levels above the reference sensitivity level for the type of MS, assuming no changes in transmitted downlink power. In *A/Gb mode*, the requirements apply for full rate TCH, E-TCH and O-TCH (no DTX). Similarly in *Iu mode*, the requirements apply to DBPSCH/F (no DTX). The estimated values are averaged (cf. subclause 8.2.3.2) over the reporting period of length 104 TDMA frames (480 ms). Furthermore, in both *A/Gb mode* and *Iu mode*, different requirements are given for EGPRS, in which case filtering according to subclause 10.2.3.2.1 with forgetting factor of 0.03 is assumed. The requirements for VAMOS mode shall apply for values of SCPIR from -4 dB to +4 dB for VAMOS-I and for values of SCPIR from -10 dB to +10 dB for VAMOS-II.

MEAN_BEP mapping and accuracy for GMSK

MEAN_BEP	Range of log10(actual BEP)	Expected MEAN_BEP interval	Probability that the expected MEAN_BEP is reported shall not be lower than:	
			see NOTE *)	EGPRS
MEAN_BEP_0	> -0.60	MEAN_BEP_0/1	80 %	80 %
MEAN_BEP_1	-0.70 -- -0.60	MEAN_BEP_1/0/2	80 %	80 %
MEAN_BEP_2	-0.80 -- -0.70	MEAN_BEP_2/1/3	70 %	75 %
MEAN_BEP_3	-0.90 -- -0.80	MEAN_BEP_3/2/4	70 %	75 %
MEAN_BEP_4	-1.00 -- -0.90	MEAN_BEP_4/3/5	70 %	75 %
MEAN_BEP_5	-1.10 -- -1.00	MEAN_BEP_5/4/6	70 %	75 %
MEAN_BEP_6	-1.20 -- -1.10	MEAN_BEP_6/5/7	70 %	75 %
MEAN_BEP_7	-1.30 -- -1.20	MEAN_BEP_7/6/8	70 %	75 %
MEAN_BEP_8	-1.40 -- -1.30	MEAN_BEP_8/7/9	70 %	75 %
MEAN_BEP_9	-1.50 -- -1.40	MEAN_BEP_9/8/10	70 %	75 %
MEAN_BEP_10	-1.60 -- -1.50	MEAN_BEP_10/9/11	65 %	70 %
MEAN_BEP_11	-1.70 -- -1.60	MEAN_BEP_11/10/12	65 %	70 %
MEAN_BEP_12	-1.80 -- -1.70	MEAN_BEP_12/11/13	65 %	70 %
MEAN_BEP_13	-1.90 -- -1.80	MEAN_BEP_13/12/14	65 %	70 %
MEAN_BEP_14	-2.00 -- -1.90	MEAN_BEP_14/13/15	65 %	70 %
MEAN_BEP_15	-2.10 -- -2.00	MEAN_BEP_15/13/14/16/17	70 %	80 %
MEAN_BEP_16	-2.20 -- -2.10	MEAN_BEP_16/14/15/17/18	70 %	80 %
MEAN_BEP_17	-2.30 -- -2.20	MEAN_BEP_17/15/16/18/19	70 %	80 %
MEAN_BEP_18	-2.40 -- -2.30	MEAN_BEP_18/16/17/19/20	70 %	80 %
MEAN_BEP_19	-2.50 -- -2.40	MEAN_BEP_19/17/18/20/21	70 %	80 %
MEAN_BEP_20	-2.60 -- -2.50	MEAN_BEP_20/18/19/21/22	70 %	80 %
MEAN_BEP_21	-2.70 -- -2.60	MEAN_BEP_21/19/20/22/23	70 %	80 %
MEAN_BEP_22	-2.80 -- -2.70	MEAN_BEP_22/20/21/23/24	70 %	80 %
MEAN_BEP_23	-2.90 -- -2.80	MEAN_BEP_23/21/22/24/25	70 %	80 %
MEAN_BEP_24	-3.00 -- -2.90	MEAN_BEP_24/22/23/25/26	70 %	80 %
MEAN_BEP_25	-3.10 -- -3.00	MEAN_BEP_25/22/23/24/26/27/28	65 %	75 %
MEAN_BEP_26	-3.20 -- -3.10	MEAN_BEP_26/23/24/25/27/28/29	65 %	75 %
MEAN_BEP_27	-3.30 -- -3.20	MEAN_BEP_27/24/25/26/28/29/30	65 %	75 %
MEAN_BEP_28	-3.40 -- -3.30	MEAN_BEP_28/25/26/27/29/30/31	65 %	75 %
MEAN_BEP_29	-3.50 -- -3.40	MEAN_BEP_29/26/27/28/30/31	80 %	90 %
MEAN_BEP_30	-3.60 -- -3.50	MEAN_BEP_30/27/28/29/31	80 %	90 %
MEAN_BEP_31	< -3.60	MEAN_BEP_31/28/29/30	80 %	90 %

NOTE *) The values in this column apply in *A/Gb mode* for full rate TCH (no DTX) in non VAMOS mode, and in *Iu mode* for DBPSCH/F (no DTX).

MEAN_BEP mapping and accuracy for 8PSK

MEAN_BEP	Range of log10(actual BEP)	Expected MEAN_BEP interval	Probability that the expected MEAN_BEP is reported shall not be lower than:	
			see NOTE *)	EGPRS
MEAN_BEP_0	> -0.60	MEAN_BEP_0/1/2	80 %	85 %
MEAN_BEP_1	-0.64 -- -0.60	MEAN_BEP_1/0/2/3	80 %	85 %
MEAN_BEP_2	-0.68 -- -0.64	MEAN_BEP_2/0/1/3/4	80 %	85 %
MEAN_BEP_3	-0.72 -- -0.68	MEAN_BEP_3/1/2/4/5	80 %	85 %
MEAN_BEP_4	-0.76 -- -0.72	MEAN_BEP_4/2/3/5/6	80 %	85 %
MEAN_BEP_5	-0.80 -- -0.76	MEAN_BEP_5/3/4/6/7	80 %	85 %
MEAN_BEP_6	-0.84 -- -0.80	MEAN_BEP_6/4/5/7/8	80 %	85 %
MEAN_BEP_7	-0.88 -- -0.84	MEAN_BEP_7/5/6/8/9	80 %	85 %
MEAN_BEP_8	-0.92 -- -0.88	MEAN_BEP_8/6/7/9/10	70 %	80 %
MEAN_BEP_9	-0.96 -- -0.92	MEAN_BEP_9/7/8/10/11	70 %	80 %
MEAN_BEP_10	-1.00 -- -0.96	MEAN_BEP_10/8/9/11/12	70 %	80 %
MEAN_BEP_11	-1.04 -- -1.00	MEAN_BEP_11/9/10/12/13	70 %	80 %
MEAN_BEP_12	-1.08 -- -1.04	MEAN_BEP_12/10/11/13/14	70 %	80 %
MEAN_BEP_13	-1.12 -- -1.08	MEAN_BEP_13/11/12/14/15	70 %	80 %
MEAN_BEP_14	-1.16 -- -1.12	MEAN_BEP_14/12/13/15/16	80 %	85 %
MEAN_BEP_15	-1.20 -- -1.16	MEAN_BEP_15/13/14/16	80 %	85 %
MEAN_BEP_16	-1.36 -- -1.20	MEAN_BEP_16/14/15/17	80 %	85 %
MEAN_BEP_17	-1.52 -- -1.36	MEAN_BEP_17/16/18	90 %	95 %
MEAN_BEP_18	-1.68 -- -1.52	MEAN_BEP_18/17/19	90 %	95 %
MEAN_BEP_19	-1.84 -- -1.68	MEAN_BEP_19/18/20	90 %	95 %
MEAN_BEP_20	-2.00 -- -1.84	MEAN_BEP_20/19/21	90 %	95 %
MEAN_BEP_21	-2.16 -- -2.00	MEAN_BEP_21/20/22	80 %	85 %
MEAN_BEP_22	-2.32 -- -2.16	MEAN_BEP_22/21/23	80 %	85 %
MEAN_BEP_23	-2.48 -- -2.32	MEAN_BEP_23/22/24	80 %	85 %
MEAN_BEP_24	-2.64 -- -2.48	MEAN_BEP_24/23/25	80 %	85 %
MEAN_BEP_25	-2.80 -- -2.64	MEAN_BEP_25/23/24/26/27	80 %	85 %
MEAN_BEP_26	-2.96 -- -2.80	MEAN_BEP_26/24/25/27/28	80 %	85 %
MEAN_BEP_27	-3.12 -- -2.96	MEAN_BEP_27/25/26/28/29	70 %	80 %
MEAN_BEP_28	-3.28 -- -3.12	MEAN_BEP_28/26/27/29/30	70 %	80 %
MEAN_BEP_29	-3.44 -- -3.28	MEAN_BEP_29/27/28/30/31	70 %	80 %
MEAN_BEP_30	-3.60 -- -3.44	MEAN_BEP_30/28/29/31	80 %	90 %
MEAN_BEP_31	< -3.60	MEAN_BEP_31/29/30	80 %	90 %

NOTE *) The values in this column apply in *A/Gb mode* for full rate E-TCH and O-TCH (no DTX), and in *Lu mode* for DBPSCH/F (no DTX).

MEAN_BEP mapping and accuracy for AQPSK (for VAMOS-I MS and for VAMOS-II MS)

MEAN_BEP	Range of log10(actual BEP)	Expected MEAN_BEP interval	Probability that the expected MEAN_BEP is reported shall not be lower than:
			see NOTE *)
MEAN_BEP_0	> -0.60	MEAN_BEP_0/1/2	80 %
MEAN_BEP_1	-0.70 -- -0.60	MEAN_BEP_1/0/2/3/4	80 %
MEAN_BEP_2	-0.80 -- -0.70	MEAN_BEP_2/1/3/4/5	70 %
MEAN_BEP_3	-0.90 -- -0.80	MEAN_BEP_3/2/4/5	70 %
MEAN_BEP_4	-1.00 -- -0.90	MEAN_BEP_4/3/5/6	70 %
MEAN_BEP_5	-1.10 -- -1.00	MEAN_BEP_5/3/4/6/7	70 %
MEAN_BEP_6	-1.20 -- -1.10	MEAN_BEP_6/4/5/7/8	70 %
MEAN_BEP_7	-1.30 -- -1.20	MEAN_BEP_7/5/6/8/9	70 %
MEAN_BEP_8	-1.40 -- -1.30	MEAN_BEP_8/5/6/7/9/10	70 %
MEAN_BEP_9	-1.50 -- -1.40	MEAN_BEP_9/6/7/8/10/11	70 %
MEAN_BEP_10	-1.60 -- -1.50	MEAN_BEP_10/7/8/9/11/12	65 %
MEAN_BEP_11	-1.70 -- -1.60	MEAN_BEP_11/8/9/10/12/13	65 %
MEAN_BEP_12	-1.80 -- -1.70	MEAN_BEP_12/9/10/11/13/14	65 %
MEAN_BEP_13	-1.90 -- -1.80	MEAN_BEP_13/10/11/12/14/15	65 %
MEAN_BEP_14	-2.00 -- -1.90	MEAN_BEP_14/11/12/13/15/16	65 %
MEAN_BEP_15	-2.10 -- -2.00	MEAN_BEP_15/11/12/13/14/16/17	70 %
MEAN_BEP_16	-2.20 -- -2.10	MEAN_BEP_16/13/14/15/17/18	70 %
MEAN_BEP_17	-2.30 -- -2.20	MEAN_BEP_17/14/15/16/18/19	70 %
MEAN_BEP_18	-2.40 -- -2.30	MEAN_BEP_18/14/15/16/17/19/20	70 %
MEAN_BEP_19	-2.50 -- -2.40	MEAN_BEP_19/15/16/17/18/20/21	70 %
MEAN_BEP_20	-2.60 -- -2.50	MEAN_BEP_20/16/17/18/19/21/22	70 %
MEAN_BEP_21	-2.70 -- -2.60	MEAN_BEP_21/17/18/19/20/22/23	70 %
MEAN_BEP_22	-2.80 -- -2.70	MEAN_BEP_22/18/19/20/21/23/24	70 %
MEAN_BEP_23	-2.90 -- -2.80	MEAN_BEP_23/19/20/21/22/24/25	70 %
MEAN_BEP_24	-3.00 -- -2.90	MEAN_BEP_24/20/21/22/23/25/26	70 %
MEAN_BEP_25	-3.10 -- -3.00	MEAN_BEP_25/21/22/23/24/26/27/28	65 %
MEAN_BEP_26	-3.20 -- -3.10	MEAN_BEP_26/22/23/24/25/27/28/29	65 %
MEAN_BEP_27	-3.30 -- -3.20	MEAN_BEP_27/23/24/25/26/28/29/30	65 %
MEAN_BEP_28	-3.40 -- -3.30	MEAN_BEP_28/23/24/25/26/27/29/30/31	65 %
MEAN_BEP_29	-3.50 -- -3.40	MEAN_BEP_29/23/24/25/26/27/28/30/31	80 %
MEAN_BEP_30	-3.60 -- -3.50	MEAN_BEP_30/24/25/26/27/28/29/31	80 %
MEAN_BEP_31	< -3.60	MEAN_BEP_31/27/28/29/30	80 %

NOTE *) The values in this column apply in *A/Gb mode* for full rate TCH (no DTX) in VAMOS mode.

For a coding on 4 bits, the 4 most significant bits are used.

NOTE1: MEAN_BEP is calculated and filtered in a linear scale but mapped to a logarithmic scale for reporting.

NOTE2: The accuracy requirements above take into account possible fluctuations of the bit error rate due to adaptiveness of receivers.

NOTE3: Testing requires measurement of the actual bit error rate and assessment of MEAN_BEP reports based on the same period of time.

The mapping table for the coefficient of variation of the channel quality is defined as follows for AQPSK, 8-PSK and GMSK:

CV_BEP 0	2.00	> CV_BEP >	1.75
CV_BEP 1	1.75	> CV_BEP >	1.50
CV_BEP 2	1.50	> CV_BEP >	1.25
CV_BEP 3	1.25	> CV_BEP >	1.00
CV_BEP 4	1.00	> CV_BEP >	0.75
CV_BEP 5	0.75	> CV_BEP >	0.50
CV_BEP 6	0.50	> CV_BEP >	0.25
CV_BEP 7	0.25	> CV_BEP >	0.00

The accuracy requirements for CV_BEP need not be specified since they are directly linked to those for MEAN_BEP. Nevertheless, the CV_BEP measured at the MS shall be the one used by this MS.

8.3 Aspects of discontinuous transmission (DTX)

When DTX is employed on a TCH, not all TDMA frames may be transmitted. However, the following subset shall always be transmitted, except for TCH/AFS, TCH/WFS, O-TCH/WFS, TCH/AHS, O-TCH/AHS and O-TCH/WHS, and hence can be employed to assess quality and signal level during DTX.

Type of channel	TDMA frame subset always to be transmitted TDMA frame number (FN) modulo 104
TCH/F	52, 53, 54, 55, 56, 57, 58, 59
TCH/HS,subchannel 0	0, 2, 4, 6, 52, 54, 56, 58
TCH/HS,subchannel 1	14, 16, 18, 20, 66, 68, 70, 72
TCH/H,data,subchannel 0,uplink	52, 54, 56, 58, 60, 62, 65, 67, 69, 71
TCH/H,data,subchannel 0,downlink	56, 58, 60, 62, 65, 67, 69, 71, 73, 75
TCH/H,data,subchannel 1,uplink	70, 72, 74, 76, 79, 81, 83, 85, 87, 89
TCH/H,data,subchannel 1,downlink	66, 68, 70, 72, 74, 76, 79, 81, 83, 85

This subset of TDMA frames is always used for transmission during DTX. For speech TCH, when no signalling or speech is to be transmitted these TDMA frames are occupied by the SID (Silence Descriptor) frame, see 3GPP TS 46.012 and 3GPP TS 46.031 for detailed specification of the SID frame and its transmission requirements. For data TCH when no information is required to be transmitted, the L2 fill frame (see 3GPP TS 44.006 subclause 5.4.2.3) shall be transmitted as a FACCH in the TDMA frame subset always to be transmitted. For PDTCH on DBPSCH in *lu mode*, when no information is required to be transmitted a dummy block (see 3GPP TS 44.160) shall be sent as a PACCH in the TDMA frame subset always to be transmitted.

On the SDCCH and on the half rate traffic channel TCH/H in signalling only mode DTX is not allowed. In these cases and on the TCH/F in signalling only mode when DTX is not used, the same L2 fill frame shall be transmitted in case there is nothing else to transmit.

On TCH/AFS, TCH/WFS, O-TCH/WFS, TCH/AHS, O-TCH/AHS and O-TCH/WHS, there is no fixed subset of TDMA frames that will always be transmitted during DTX. A detection algorithm is required in the receiver which informs about whether a SID_UPDATE (see 3GPP TS 45.003 and 3GPP TS 26.093) frame was transmitted (and thus can be used for quality and signal level estimation) or not.

If no FPC commands are received during a reporting period, the SACCH power command shall be used.

In *lu mode*, when DTX is employed on a DBPSCH with PDTCH or FLO, not all TDMA frames may be transmitted. However a minimum number of blocks shall always be transmitted during DTX. When nothing but SACCH blocks are transmitted (hereafter referred to as silent period), the following rules ensure that L2 dummy blocks (see 3GPP TS 44.160) are at least transmitted, according to the configuration of the DBPSCH (see 3GPP TS 44.118):

- when 4 bursts rectangular interleaving is used on DBPSCH/F (PDTCH/F or FLO), a L2 dummy block shall be sent after every silent period of 44 TDMA frames, excluding SACCH and idle frames (i.e. 220ms).
- when 8 bursts diagonal interleaving is used on DBPSCH/F (FLO), a L2 dummy block shall be sent after every silent period of 40 TDMA frames, excluding SACCH and idle frames (i.e. 200ms).
- when 4 bursts rectangular interleaving is used on DBPSCH/H (PDTCH/H or FLO), or when 4 bursts diagonal interleaving is used on DBPSCH/H (FLO), a L2 dummy block shall be sent after every silent period of 20 TDMA frames, excluding SACCH and idle frames (i.e. 200ms).

8.4 Measurement reporting

8.4.1 Measurement reporting for the MS

In *A/Gb mode*, for a TCH with a training sequence in TSC Set 1, or for a TCH with a training sequence in TSC Set 2 assigned to VAMOS I MS, and in *Iu mode*, for a DBPSCH, the reporting period of length 104 TDMA frames (480 ms) is defined in terms of TDMA frame numbers (FN) as follows:

Timeslot number (TN)			TDMA frame number (FN) modulo 104	
Full Rate	Half rate, subch.0	Half rate, subch.1	Reporting period	SACCH Message block
0	0 and 1		0 to 103	12, 38, 64, 90
1		0 and 1	13 to 12	25, 51, 77, 103
2	2 and 3		26 to 25	38, 64, 90, 12
3		2 and 3	39 to 38	51, 77, 103, 25
4	4 and 5		52 to 51	64, 90, 12, 38
5		4 and 5	65 to 64	77, 103, 25, 51
6	6 and 7		78 to 77	90, 12, 38, 64
7		6 and 7	91 to 90	103, 25, 51, 77

In *A/Gb mode*, for a TCH with a training sequence in TSC Set 2 assigned to a VAMOS II MS, the reporting period of length 104 TDMA frames (480 ms) is defined in terms of TDMA frame numbers (FN) as follows:

Timeslot number (TN)			TDMA frame number (FN) modulo 104	
Full Rate	Half rate, subch.0	Half rate, subch.1	Reporting period	SACCH Message block
0	0 and 1		0 to 103	13, 39, 65, 91
1		0 and 1	13 to 12	24, 50, 76, 102
2	2 and 3		26 to 25	39, 65, 91, 13
3		2 and 3	39 to 38	50, 76, 102, 24
4	4 and 5		52 to 51	65, 91, 13, 39
5		4 and 5	65 to 64	76, 102, 24, 50
6	6 and 7		78 to 77	91, 13, 39, 65
7		6 and 7	91 to 90	102, 24, 50, 76

For a multislot configuration, the reporting period and SACCH Message block for each timeslot is defined as for TCH/F or PDTCH/F or DBPSCH/F for TN = 0.

In *A/Gb mode*, when on a TCH, or in *Iu mode*, when on a DBPSCH, the MS shall assess during the reporting period and transmit to the BSS in the next SACCH message block the following:

- RXLEV for the BCCH carrier of the 6 cells with the highest RXLEV among those with known and allowed NCC part of BSIC. For a multi band MS the number of cells, for each frequency band supported, which shall be included is specified in subclause 8.4.3. For a cell of other radio access technology, see subclauses 8.1.5 and 8.4.7.

NOTE 1: Since there are 104 TDMA frames in each SACCH multiframe (and measurement in 4 frames is optional), the number of samples on each BCCH carrier will depend on the number of carriers defined in the BCCH Allocation (BA) and may be different. The following table gives examples of this.

Number of BCCH carriers in BCCH Allocation	Number of samples per carrier in SACCH multiframe
32	3-4
16	6-7
10	10-11
8	12-13
:	:
:	:

These figures are increased if the MS is able to make measurements on more than one BCCH carrier during each TDMA frame.

- **RXLEV_FULL and RXQUAL_FULL:**
In *A/Gb mode*, RXLEV and RXQUAL for the full set of TCH and SACCH TDMA frames. The full set of TDMA frames is either 100 (i.e. 104 - 4 idle) frames for a full rate TCH or 52 frames for a half-rate TCH. Similarly in *Iu mode* on DBPSCH, RXLEV and RXQUAL for the full set of TDMA frames. The full set of TDMA frames is either 100 frames for a full rate DBPSCH or 52 frames for a half-rate DBPSCH.
- **RXLEV_SUB and RXQUAL_SUB:**
RXLEV and RXQUAL for the subset of 4 SACCH frames and the SID TDMA frames/ SID_UPDATE frames/L2 fill frames/dummy blocks defined in 8.3.
In case of data traffic channels TCH/F9.6, TCH/F4.8, TCH/H4.8 and TCH/H2.4, the RXQUAL_SUB report shall include measurements on the TDMA frames given in the table of subclause 8.3 only if L2 fill frames have been received as FACCH frames at the corresponding frame positions. If no FACCH frames have been received at the corresponding frame positions, the RXQUAL_SUB report shall include measurements on the 4 SACCH frames only. The performance requirements of subclause 8.2.4 do not apply in this case for RXQUAL_SUB.
In *Iu mode*, when DTX is employed on a DBPSCH with PDTCH or FLO, RXQUAL_SUB report shall include either measurements on positions given in subclause 8.3 only if L2 dummy blocks have been received at the corresponding positions, or measurements on positions where radio blocks (PDTCH) or radio packets (FLO) were correctly received (see subclause 8.4.8.2 or 8.2.3.2 respectively). If no L2 dummy blocks have been received at the corresponding frame positions, or if no radio blocks or radio packets have been correctly received, the RXQUAL_SUB report shall include measurements on the 4 SACCH frames only. The performance requirements of subclause 8.2.4 do not apply in this case for RXQUAL_SUB.
In case of half rate speech channel TCH/HS, if an SID frame or a speech frame as defined in subclause 8.3 is replaced by an FACCH frame, the RXQUAL measurement on these frames shall be excluded from the RXQUAL SUB report. The performance requirements of subclause 8.2.4 do not apply in this case for RXQUAL SUB.
In case of half rate traffic channel TCH/H in signalling only mode, -SUB values are set equal to the -FULL values in the SACCH message, since DTX is not allowed in this case.
In the case of TCH/AFS, TCH/WFS, O-TCH/WFS, TCH/AHS, O-TCH/AHS or O-TCH/WHS, the RXLEV_SUB and RXQUAL_SUB shall take into account all detected SID_UPDATE frames in addition to the 4 SACCH frames. The performance requirements of subclause 8.2.4 for RXQUAL_SUB apply only for active DTX periods.

NOTE 2: If measurement on the BCCH carrier is not used, the number of TDMA frames used in the RXLEV averaging process may be lower than the number of TDMA frames in the set see subclause 8.1.3.

In case of a multislot configuration, the MS shall report the following according to the definition above:

- on the main SACCH: the RXLEV values from the adjacent cells, RXLEV_FULL and RXLEV_SUB from the main channel and the worst RXQUAL_FULL values and RXQUAL_SUB values from the main channel and the unidirectional channels;
- on each other bi-directional SACCH: the RXLEV values from the adjacent cells, RXLEV_FULL, RXLEV_SUB, RXQUAL_FULL and RXQUAL_SUB from the corresponding channel.

8.4.1a Measurement reporting for the MS in FPC mode

For an E-TCH, the FPC reporting period of length 4 TDMA frames (20 ms) is defined according to chapter 4.7,

When on an E-TCH using 8PSK for the uplink, the MS shall, in addition to what is specified in chapter 8.4.1, assess during the FPC reporting period and transmit to the BSS in the next scheduled FPC inband message (see chapter 4.7) the following:

- **RXQUAL_FAST:**
RXQUAL for the set of 4 TDMA frames.

8.4.1b Measurement reporting for the MS in EPC mode

In *A/Gb mode*, for a TCH with a training sequence in TSC Set 1 in enhanced power control (EPC) mode, or for a TCH with a training sequence in TSC Set 2 assigned to VAMOS I MS in enhanced power control (EPC) mode, or

O-TCH in enhanced power control (EPC) mode, and in *Iu mode*, for a DBPSCH in EPC mode, the EPC reporting period of length 26 TDMA frames (120 ms) is defined in terms of TDMA frame numbers (FN) as follows:

Timeslot number (TN)			TDMA frame number (FN) modulo 26	
Full rate	Half rate, subch.0	Half rate, subch.1	Reporting period	EPCCH Message block
0,2,4,6 1,3,5,7	0...7	0...7	0 to 25 13 to 12	12 25

In *A/Gb mode*, for a TCH with a training sequence in TSC Set 2 assigned to VAMOS II MS in enhanced power control (EPC) mode, the EPC reporting period of length 26 TDMA frames (120 ms) is defined in terms of TDMA frame numbers (FN) as follows:

Timeslot number (TN)			TDMA frame number (FN) modulo 26	
Full rate	Half rate, subch.0	Half rate, subch.1	Reporting period	EPCCH Message block
0,2,4,6 1,3,5,7	0...7	0...7	0 to 25 13 to 12	13 24

For a multislot configuration, the EPC reporting period and EPCCH Message block for each timeslot is defined as for a full rate channel for TN = 0.

In *A/Gb mode*, for a TCH or O-TCH in EPC mode, and in *Iu mode*, for a DBPSCH in EPC mode, the MS shall, in addition to what is specified in subclause 8.4.1, transmit an EPC Downlink Quality Report to the BSS in each scheduled EPCCH on the uplink, containing the assessed RXQUAL_EPC (as specified in subclause 8.2.3.1). During one EPC reporting period, The RXQUAL_EPC corresponding to the previous EPC reporting period shall be reported.

In case of a multislot configuration, the MS shall report the following according to the definition above:

- on the main SACCH: the worst RXQUAL_EPC value from the main channel and the unidirectional channels;
- on each other bi-directional SACCH: the RXQUAL_EPC from the corresponding channel.

8.4.2 Measurement reporting for the MS on a SDCCH

For a SDCCH, the reporting period of length 102 TDMA frames (470.8 ms) is defined in terms of TDMA frame numbers (FN) as follows:

	TDMA frame number (FN) modulo 102
SDCCH/8	12 to 11
SDCCH/4	37 to 36

NOTE 1: Some SDCCH data or TCH speech, data or SID message blocks are spread over two reporting periods. In these cases, the RXLEV and/or RXQUAL information from the SDCCH or TCH message blocks may either be sent as part of the measurement report of the second period, or shared between the reports of the two periods.

When on a SDCCH, the MS shall assess during the reporting period and transmit to the BSS in the next SACCH message block the following:

- RXLEV for the BCCH carrier of the 6 cells with the highest RXLEV among those with known and allowed NCC part of BSIC. For a multi band MS the number of cells, for each frequency band supported, which shall be included is specified in subclause 8.4.3. For a cell of other radio access technology, see subclauses 8.1.5 and 8.4.7.

NOTE 2: With only 102 TDMA frames in each SACCH multiframe, the number of samples used to calculate RXLEV per BCCH carrier may be slightly different from the case of TCH described above.

- RXLEV and RXQUAL for the full set of 12 (8 SDCCH and 4 SACCH) frames within the reporting period. As DTX is not allowed on the SDCCH, -SUB values are set equal to the -FULL values in the SACCH message.

NOTE 3: If measurement on the BCCH carrier is not used, the number of TDMA frames used in the RXLEV averaging process may be lower than the number of TDMA frames in the full set see subclause 8.1.3.

8.4.3 Additional cell reporting requirements for multi band MS

For a multi band MS the number of cells, for each frequency band supported, which shall be included in the measurement report is indicated by the parameter MULTIBAND_REPORTING, broadcast on BCCH and PBCCH. An MS attached to GPRS shall use the parameter broadcast on PBCCH if it exists (See sub-clause 1.4). In all other cases, the MS shall use the parameter broadcast on BCCH. The parameter may also be sent to the MS on SACCH.

The meaning of different values of the parameter is specified as follows:

Value	Meaning
00	Normal reporting of the six strongest cells, with known and allowed NCC part of BSIC, irrespective of the band used.
01	The MS shall report the strongest cell, with known and allowed NCC part of BSIC, in each of the frequency bands in the BA list, excluding the frequency band of the serving cell. The remaining positions in the measurement report shall be used for reporting of cells in the band of the serving cell. If there are still remaining positions, these shall be used to report the next strongest identified cells in the other bands irrespective of the band used.
10	The MS shall report the two strongest cells, with known and allowed NCC part of BSIC, in each of the frequency bands in the BA list, excluding the frequency band of the serving cell. The remaining positions in the measurement report shall be used for reporting of cells in the band of the serving cell. If there are still remaining positions, these shall be used to report the next strongest identified cells in the other bands irrespective of the band used.
11	The MS shall report the three strongest cells, with known and allowed NCC part of BSIC, in each of the frequency bands in the BA list, excluding the frequency band of the serving cell. The remaining positions in the measurement report shall be used for reporting of cells in the band of the serving cell. If there are still remaining positions, these shall be used to report the next strongest identified cells in the other bands irrespective of the band used.

8.4.4 Common aspects for the MS on a TCH, a SDCCH or a DBPSCH

In *A/Gb mode*, whether the MS is on a TCH or a SDCCH, and in *Iu mode* when the MS is on a DBPSCH, if an SACCH message block is used for a different Layer 3 message, the measurement report that would otherwise be sent in that block is discarded and a new measurement report provided for the next SACCH message.

The MS shall also transmit a bit (DTX_USED) in the next SACCH message block, which indicates whether or not it has employed DTX during the reporting period. This bit shall be set even if just one burst in a TDMA frame in the reporting period was not transmitted due to DTX.

NOTE: A speech or user data frame subject to DTX may cross the "border" between two reporting periods, in which case both of the associated SACCH message blocks will have the DTX_USED flag set.

The measurements in the MS shall be based on the current BA list and the current NCC_PERMITTED (see table 1), available at the beginning of the reporting period. At the transition from idle mode to a TCH or a SDCCH the current BA list is the BA(BCCH), later the latest received complete BA(SACCH). A complete BA(SACCH) for a MS shall be that contained in SI 5 and additionally SI 5bis if the EXT-IND bit in the Neighbour Cell Description information element in both the SI 5 and SI 5bis messages indicates that each information element only carries part of the BA. If a SI 5ter message is subsequently received and not ignored (see 3GPP TS 44.018) the BA(SACCH) shall be modified accordingly.

At the transition from idle mode to a TCH or a SDCCH in *A/Gb mode*, and to a DBPSCH in *Iu mode*, the current NCC is the NCC_PERMITTED received on the BCCH, later the latest NCC_PERMITTED received on the SACCH. The measurement process on carriers contained in both lists is, therefore, continuous.

If the current BA list does not refer to the serving cell, e.g. after a handover, this shall be indicated and no measurement values for cells in the BA list shall be reported.

If the MS returns to the previous cell after a failure of the handover procedure the description above applies. As a consequence, a BA list (and/or NCC_PERMITTED) received on the SACCH in the cell to which the handover failed shall be regarded as the current ones, which may lead to interruptions in the measurement reporting as the BA list does not refer to the serving cell. As an option, the MS may in this case remember the last received BA list and NCC_PERMITTED in the old cell and regard those as the current ones when returning.

What is said in this subclause about the BA list also applies to the GSM neighbour cell list when using enhanced measurement reporting and to the 3G neighbour cell list for a multi-RAT MS. The rules for building of and changing between neighbour cell lists are defined in 3GPP TS 44.018.

8.4.5 Measurement reporting for the BSS

In *A/Gb mode*, unless otherwise specified by the operator, the BSS shall make the same RXLEV (full and sub) and RXQUAL (full and sub) assessments as described for the MS for all TCH's and SDCCH's assigned to an MS, using the associated reporting periods. Similarly in *Iu mode*, unless otherwise specified by the operator, the BSS shall make the same RXLEV (full and sub) and RXQUAL (full and sub) assessments as described for the MS for all DBPSCH's assigned to an MS, using the associated reporting periods. These values, together with the reported values from the MS, shall be transmitted to the BSC as described in the 3GPP TS 48.058.

8.4.6 Extended measurement reporting

When on a TCH or SDCCH in *A/Gb mode*, or when on a DBPSCH in *Iu mode*, the mobile station may receive an Extended Measurement Order (EMO) message. The mobile station shall then, during one reporting period, perform received signal level measurements according to the frequency list contained in the EMO message. BSIC decoding is not required for these frequencies. The mobile station shall then transmit the measurement results in one single Extended Measurement Report message, containing the following:

- RXLEV (as defined in subclause 8.1.4) for the carriers specified by the last received EMO message. If the EMO contains more than 21 carriers, only the 21 first carriers in the sorted EXTENDED MEASUREMENT FREQUENCY LIST (in the EMO) are measured and reported.
- DTX USED, as defined in subclause 8.4.4.

NOTE: the position of the signal strength measurement samples performed by the mobile station, and the duration of these samples are not known in a TDMA frame. Consequently, in case the signal level on the carrier the MS has to monitor is not constant, the MS will report as the RXLEV value, the signal strength measurements performed during its sampling period. This value can be different from the mean value of the signal level on the whole frame.

If reporting is not possible due to requirements to send other Layer 3 messages, the measurements shall either be discarded and new measurements scheduled at the next possible opportunity or saved and transmitted at the next possible opportunity. If extended measurements can not be reported within 10 seconds after the triggering EMO was received, they shall be discarded (and not reported).

If the EMO message contains frequencies outside the MS' frequency band, the MS shall set the corresponding RXLEV value(s) to zero.

After a successful channel change, no Extended Measurement Report shall be sent if the EMO was received before that channel change.

After having performed Extended Measurements during one reporting period, the mobile station shall resume the measurements according to the current BA list. This applies for each rescheduling of the Extended measurements.

8.4.7 Additional cell reporting requirements for multi-RAT MS

A multi-RAT MS shall report the number of best valid cells, in each supported other radio access technology/mode in the neighbour cell list or on frequencies contained in the E-UTRAN Neighbour Cell list, according to the value of the parameters `XXX_MULTIRAT_REPORTING` (`XXX` indicates radio access technology/mode).

For UTRAN FDD, only cells with a reported value (CPICH Ec/No or CPICH RSCP) equal or higher than `FDD_REPORTING_THRESHOLD` and a non-reported value (CPICH Ec/No or CPICH RSCP) equal or higher than `FDD_REPORTING_THRESHOLD_2`, shall be reported.

For UTRAN TDD, only cells with a reported value (P-CCPCH RSCP) equal or higher than `TDD_REPORTING_THRESHOLD` shall be reported.

For E-UTRAN FDD or E-UTRAN TDD, when 6-bit measurement reporting is used only cells with a reported value (RSRP or RSRQ) equal or higher than `E-UTRAN_FDD_REPORTING_THRESHOLD` or `E-UTRAN_TDD_REPORTING_THRESHOLD` and with a non-reported value (RSRP or RSRQ) equal or higher than `E-UTRAN_FDD_REPORTING_THRESHOLD_2` or `E-UTRAN_TDD_REPORTING_THRESHOLD_2`, respectively, shall be reported. When 3-bit measurement reporting is used only cells with a measured value (RSRP or RSRQ) equal or higher than `E-UTRAN_FDD_MEASUREMENT_REPORT_OFFSET` or `E-UTRAN_TDD_MEASUREMENT_REPORT_OFFSET` and with a non-reported value (RSRP or RSRQ) equal or higher than `E-UTRAN_FDD_REPORTING_THRESHOLD_2` or `E-UTRAN_TDD_REPORTING_THRESHOLD_2`, respectively, shall be reported.

If there are more valid non-GSM cells than can be reported, the MS shall select the cells for each supported RAT/mode for which `XXX_MULTIRAT_REPORTING` is non-zero according to the following procedure:

1. For each RAT/mode the best valid cell of each RAT/mode is included in the report. The best cell is the cell with the highest reported value (see subclause 8.1.5).
2. If there are further positions and cells available, the MS shall additionally include in the report the next best valid cell on each RAT/mode for which `XXX_MULTIRAT_REPORTING` cells have not yet been included. In case this would result in including more cells than there are remaining spaces in the measurement report, priority is given to cells from RATs/modes with higher `XXX_MULTIRAT_REPORTING` value. In case of equal `XXX_MULTIRAT_REPORTING` values, the cell for which (6 bit reported value – `XXX_REPORTING_THRESHOLD` + `XXX_REPORTING_OFFSET`) is highest is reported.

6 bit mapping for reported values shall be used in the calculations even if 3 bit reporting is used. In this case, instead of `E-UTRAN_FDD_REPORTING_THRESHOLD` or `E-UTRAN_TDD_REPORTING_THRESHOLD` the mobile station shall use the 6 bit mapped value from `E-UTRAN_FDD_MEASUREMENT_REPORT_OFFSET` or `E-UTRAN_TDD_MEASUREMENT_REPORT_OFFSET` respectively, using the mapping table defined in subclause 8.1.5.4 for E-UTRAN FDD or subclause 8.1.5.5 for E-UTRAN TDD.

3. Step 2 is repeated until either all positions are used or no more cells are to be reported (because, for each RAT/mode, either `XXX_MULTIRAT_REPORTING` cells have been reported, or there are no more valid cells to report).

The remaining positions in the measurement report shall be used for reporting of GSM cells as defined in subclause 8.4.3.

If there are still remaining positions, these shall be used to report the next best valid cells in supported other radio access technologies for which `XXX_MULTIRAT_REPORTING` is non-zero. The best cell is the cell with the highest quantity of (6 bit reported value – `XXX_REPORTING_THRESHOLD` + `XXX_REPORTING_OFFSET`).

If the neighbour cell list contains a UTRAN FDD frequency for RSSI reporting, an RSSI report on that frequency shall be included when and only when a cell on that frequency is also reported (RSSI shall be reported at most once per frequency occurrence in the neighbouring cell list). RSSI measurements for frequencies contained in the neighbour cell list shall be reported with high priority and shall be reported before measurements on valid 3G cell, in case of not available positions.

NOTE: The parameter `XXX_MULTIRAT_REPORTING` indicates a number of cells to be reported in a measurement report message and does not include the number of places taken by RSSI reporting in the measurement report message. In the case of E-UTRAN there is only one parameter `E-UTRAN_MULTIRAT_REPORTING` that indicates the number of cells to be reported in a measurement report message regardless of mode.

If no measurements have been performed on a cell since last report, the cell shall not be included in the report.

For UTRAN FDD, valid cells are identified cells where the primary CPICH has been received when using the scrambling code provided for that frequency in the neighbour cell list.

For UTRAN TDD, valid cells are identified cells with correct cell parameter and sync case provided for that frequency in the neighbour cell list.

For cdma2000, valid cells are identified cells with correct Pilot PN sequence offset index (PILOT_PN, as defined in TIA/EIA/IS-2000-A) provided for that frequency in the neighbour cell list.

For E-UTRAN FDD, valid cells are identified cells on frequencies included in the E-UTRAN Neighbour Cell list for which the physical-layer cell identity (see 3GPP TS 36.211) has been correctly detected and is not included in the list of not allowed cells for that frequency.

For E-UTRAN TDD, valid cells are identified cells on frequencies included in the E-UTRAN Neighbour Cell list for which the physical-layer cell identity (see 3GPP TS 36.211) has been correctly detected and is not included in the list of not allowed cells for that frequency.

The XXX_MULTIRAT_REPORTING parameters are broadcast on BCCH and, except for E-UTRAN parameters, on PBCCH. An MS attached to GPRS shall use the parameters broadcast on PBCCH if it exists (See sub-clause 1.4). In all other cases, the MS shall use the parameters broadcast on BCCH. The parameters may also be sent to the MS on SACCH.

8.4.8 Enhanced Measurement Reporting

The network may request the MS to report serving cell and neighbour cell measurements with Enhanced Measurement Report message by the parameter REPORT_TYPE, provided that BSIC for all GSM neighbour cells has been sent to the MS (See 3GPP TS 44.018). This reporting is referred as Enhanced Measurement Reporting.

If Enhanced Measurement Reporting is used, the BCCH carriers and corresponding valid BSICs of the GSM neighbour cells are sent to the MS within System Information messages and MEASUREMENT INFORMATION message (See 3GPP TS 44.018). The MEASUREMENT INFORMATION message also includes the parameters SERVING_BAND_REPORTING, MULTIBAND_REPORTING, XXX_MULTIRAT_REPORTING, XXX_REPORTING_THRESHOLD, XXX_REPORTING_OFFSET, REP_PRIORITY, REPORTING_RATE, INVALID_BSIC_REPORTING and optionally FDD_REPORTING_THRESHOLD_2, E-UTRAN_FDD_REPORTING_THRESHOLD_2 and E-UTRAN_TDD_REPORTING_THRESHOLD_2. XXX indicates, as applicable, GSM frequency band (e.g. 900, 850, etc) or other radio access technology/mode (e.g. FDD, TDD, E-UTRAN, E-UTRAN FDD, E-UTRAN TDD).

Only GSM cells with the valid BSIC shall be reported unless otherwise stated.

8.4.8.1 Reporting Priority

The MS shall include the neighbour cell measurement results using the following priority order:

- 1) the number of strongest GSM cells with known and valid BSIC and with a reported value equal or greater than XXX_REPORTING_THRESHOLD, in the frequency band of the serving cell, according to the value of the parameter SERVING_BAND_REPORTING;
- 2) the number of strongest GSM cells with known and valid BSIC and with a reported value equal or greater than XXX_REPORTING_THRESHOLD, in each of the frequency bands in the BA list, excluding the frequency band of the serving cell, according to the value of the parameter MULTIBAND_REPORTING;
- 3) the number of best valid cells and with a reported value equal or greater than XXX_REPORTING_THRESHOLD, in each supported other radio access technology/mode in the 3G neighbour cell list or on frequencies contained in the E-UTRAN Neighbour Cell list, according to the value of the parameters XXX_MULTIRAT_REPORTING. When the radio access technology/mode is UTRAN FDD, then additionally the non-reported value (from CPICH Ec/No and CPICH RSCP) shall be equal or greater than FDD_REPORTING_THRESHOLD_2. When the radio access technology/mode is E-UTRAN FDD or E-UTRAN TDD, then additionally the non-reported value (from RSRP and RSRQ) shall be equal or greater than E-UTRAN_FDD_REPORTING_THRESHOLD_2 or E-UTRAN_TDD_REPORTING_THRESHOLD_2, respectively. A valid cell is defined in subclause 8.4.7.

- 4) The remaining GSM cells with known and valid BSIC or, if indicated by the parameter `INVALID_BSIC_REPORTING`, with known and allowed NCC part of the BSIC in any frequency band and valid cells of other radio access technologies for which `XXX_MULTIRAT_REPORTING` is greater than zero. Except for cells with high reporting priority as indicated with by the parameter `REP_PRIORITY`, these cells may be reported less frequently, if indicated by the parameter `REPORTING_RATE`, but at least once in four consecutive measurement reports. For those cells that are not reported in every measurement report, the MS shall average the measurements of the current and the previous reporting period (i.e. over two reporting periods).

For UTRAN FDD cells within this priority level the non-reported value shall be equal or greater than `FDD_REPORTING_THRESHOLD_2`.

For E-UTRAN FDD and E-UTRAN TDD cells within this priority level the non-reported value shall be equal or greater than `E-UTRAN_FDD_REPORTING_THRESHOLD_2` or `E-UTRAN_TDD_REPORTING_THRESHOLD_2` respectively.

If the neighbour cell list contains a UTRAN frequency for which RSSI shall be reported, that report shall be included whenever a cell on that frequency is reported, as described in 8.4.7.

For each of the priority levels above, the following shall apply :

- if the number of valid cells is less than indicated the unused positions in the report shall be left for the lower prioritised cells;
- if there is not enough space in the report for all valid cells, the cells shall be reported for which the quantity (reported value – `XXX_REPORTING_THRESHOLD` + `XXX_REPORTING_OFFSET`) is highest, where the parameters `XXX_REPORTING_THRESHOLD` and `XXX_REPORTING_OFFSET` are for the respective radio access technology/mode. Note that this parameter shall not affect the actual reported value. If a cell can not be reported due to lack of space in the report, then no cell with a lower value shall be reported, even if one of these cells with a lower value would fit in the report.

8.4.8.2 Measurement Reporting

The reporting period shall be as specified in 8.4.1 for the MS on a TCH in *A/Gb mode* and for the MS on a DBPSCH in *Iu mode*, and as specified in 8.4.2 for the MS on a SDCCH.

When on a TCH in *A/Gb mode*, or on a DBPSCH in *Iu mode*, the MS shall assess during the reporting period and transmit to the BSS in the next SACCH message block the following:

- `RXLEV` for neighbour cells in the order defined in 8.4.8.1. For a cell of other radio access technology, see subclause 8.1.5.
- `RXQUAL_FULL`:
In *A/Gb mode*, `RXQUAL` for the full set of TCH and SACCH TDMA frames. The full set of TDMA frames is either 100 (i.e. 104 - 4 idle) frames for a full rate TCH or 52 frames for a half-rate TCH. In *Iu mode*, `RXQUAL` for the full set of TDMA frames on DBPSCH. The full set of TDMA frames is either 100 (i.e. 104 - 4 idle) frames for a full rate DBPSCH or 52 frames for a half-rate DBPSCH.
- `RXLEV_VAL`:
The average over the reporting period of `RXLEV` measured on the 4 last time slots of each fully received and correctly decoded data block (as defined for `MEAN_BEP` and `CV_BEP` in 8.2.3.2) and on all SACCH frames. For speech traffic channels, blocks that have not been erased, shall be considered as correctly decoded. For non-transparent data, blocks are considered as correctly decoded according the CRC received. For transparent data, all blocks are considered as correctly decoded. FACCH blocks are considered as correctly decoded according to the CRC.
- `MEAN_BEP` and `CV_BEP`:
The average over the reporting period of the Mean and Coefficient of Variation of the Bit Error Probability measures from blocks as defined for `RXLEV_VAL` above, excluding `CV_BEPblock` measurements from SACCH/T blocks (see subclause 8.2.3).
- `NBR_RCVD_BLOCKS`:
The number of correctly decoded blocks, as defined for `RXLEV_VAL`, (excluding all SID frames, RATSCCH, SACCH, PACCH and FACCH blocks) that were completed during the measurement report period. As an exception, FACCH or PACCH blocks shall be included in the case of signalling only mode.

For FLO in *Iu mode*, the procedure for reporting the number of correctly decoded transport blocks is defined in subclause 8.4.8.3.

NOTE: In some cases more than one data frame needs to be received in order to identify a block as correctly decoded, e.g. for 14.4 data where one RLP frame consists of two consecutive blocks. In some cases a single block carries multiple RLP frames in which case it is sufficient that one of those RLP frames is correctly received.

- BSIC_SEEN:
Indicates if a GSM cell with invalid BSIC and allowed NCC part of the BSIC is one of the six strongest cells.

In case of a multislot configuration the MS shall report the following according to the definition above:

- on the main SACCH: the RXLEV values from the adjacent cells, BSIC_SEEN, RXLEV_VAL and NBR_RCVD_BLOCKS from the main channel, the worst RXQUAL_FULL value and the worst MEAN_BEP value from the main channel and the unidirectional channels and the CV_BEP value from the same channel as the reported MEAN_BEP;
- on each other bi-directional SACCH: the RXLEV values from the adjacent cells, BSIC_SEEN, RXLEV_VAL, NBR_RCVD_BLOCKS, RXQUAL_FULL, MEAN_BEP and CV_BEP from the corresponding channel.

When on a SDCCH, the MS shall assess during the reporting period and transmit to the BSS in the next SACCH message block the following:

- RXLEV for neighbour cells as defined in 8.4.8.1. For a cell of other radio access technology, see subclause 8.1.5.
- RXLEV_VAL, NBR_RCVD_BLOCKS, RXQUAL_FULL, MEAN_BEP and CV_BEP for the full set of 12 (8 SDCCH and 4 SACCH) TDMA frames within the reporting period. As DTX is not allowed on the SDCCH, measurements on all 12 TDMA frames shall be included.
- BSIC_SEEN:
Indicates if a GSM cell with invalid BSIC and allowed NCC part of the BSIC is one of the six strongest cells.

The common aspects for the MS on a TCH or a SDCCH as defined in 8.4.4 shall apply.

8.4.8.3 NBR_RCVD_BLOCKS for FLO

For reporting the number of correctly decoded transport blocks during a reporting period, the MS shall calculate the maximum number of transport blocks that can be correctly decoded during that reporting period ($NbTB_{max}$).

$NbTB_{max}$ is $24 \times$ the maximum number of active transport channels (for which a CRC is used) in a TFC of the TFCS (excluding the signalling TFC, see 3GPP TS 44.118) of the DBPSCH. If the TFCS (excluding the signalling TFC) does not contain a TFC for which at least one transport channel that uses a CRC is active, $NbTB_{max}$ becomes $24 \times$ the maximum number of active transport channel in a TFC of the TFCS (excluding the signalling TFC).

If during a reporting period, the TFCS is reconfigured by higher layers, $NbTB_{max}$ shall be the highest one among the TFCSs used during the reporting period.

When counting the correctly decoded transport blocks, the MS shall apply the two following principles:

- when a radio packet is received with the signalling TFC (the first one, the one for which the TFCI=0, see 3GPP TS 44.118), the transport block(s) it carries is(are) not counted; and
- transport blocks are considered as correctly decoded according the CRC received. If there is no CRC, the transport block is not counted unless the TFCS (excluding the signalling TFC) does not contain a TFC for which at least one transport channel that uses a CRC is active, in which case all received transport blocks are considered as correctly decoded.

NBR_RCVD_BLOCKS is obtained by truncating the least significant bit(s) of the binary representation of the number of correctly decoded transport blocks according to the table below:

Table 8.4.8.2: Truncation

NbTBmax	Truncation
0 -31	none
32 -63	1 LSB
> 63	2 LSB

8.4.9 Requirements for measurement and reporting of CSG cells and hybrid cells

The requirements in subclause 8.4.7 and 8.4.8 do not apply for the reporting of CSG cells, but the MS shall apply the rules in this subclause. A cell detected as hybrid cell which meets the criteria specified in subclause 7.4 or 10.1a shall be treated as a CSG cell for the purpose of this sub-clause; , otherwise, in respect of that cell, the rules for reporting of non-CSG cells defined in subclause 8.4.7 and 8.4.8 shall apply.

If the criteria for reporting of a CSG cell are met (see subclause 7.4 and 10.1a), the MS shall report that cell with highest priority, except that: i) a mobile station shall transmit a measurement report for a given CSG cell at most 6 times in any 60 second period (in dedicated mode or dual transfer mode) or at most 6 times in any 50 consecutive reporting periods (in packet idle mode or packet transfer mode); ii) a mobile station shall transmit a measurement report for any CSG cell at most 12 times in any 60 second period (in dedicated mode or dual transfer mode) or at most 12 times in any consecutive 50 reporting periods (in packet idle mode or packet transfer mode). The mobile station may exceed these limits and transmit additional reports for a CSG cell if there is space in the report to include the report for the CSG cell together with reports for all other valid cells (see sub-clauses 8.4.7 and 8.4.8). No more than one CSG cell shall be included in any measurement reporting message. Reporting priority between CSG cells of different RATs/modes or CSG cells from different frequencies is left implementation dependent. If there is still space in the report, the MS shall include valid neighbour non-CSG cells according to the rules defined in subclause 8.4.7 and 8.4.8.

NOTE: The autonomous search function used to detect a CSG cell is implementation dependent and no performance requirements apply for this function while the mobile station is in dedicated mode, packet transfer mode or dual transfer mode.

For UTRAN FDD CSG cells, the measurement quantities to be used are CPICH Ec/No and CPICH RSCP and their mappings are the same as for UTRAN FDD cells (see subclause 8.1.5.1). Ec/No shall be used for measurement reporting irrespective of the parameter FDD_REP_QUANT.

For UTRAN TDD CSG cells, the measurement quantity to be used is P-CCPCH RSCP and its mapping is the same as for UTRAN TDD cells (see subclause 8.1.5.2). RSCP shall be used for measurement reporting.

For E-UTRAN FDD CSG cells, the measurement quantities to be used are RSRQ and RSRP and their mappings are the same as for E-UTRAN FDD cells (see subclause 8.1.5.4). RSRQ shall be used for measurement reporting irrespective of the parameter E-UTRA_REP_QUANT.

For E-UTRAN TDD CSG cells, the measurement quantities to be used are RSRQ and RSRP and their mappings are the same as for UTRAN TDD cells (see subclause 8.1.5.4). RSRQ shall be used for measurement reporting irrespective of the parameter E-UTRA_REP_QUANT.

8.5 Absolute MS-BTS distance

8.5.1 General

The Absolute MS-BTS distance may be employed by the network as a criterion in the handover processes.

8.5.2 Physical parameter

The information being used by the BSS to perform "adaptive frame alignment" (3GPP TS 45.010) in the MS is a representation of the absolute distance of the MS to the serving BTS.

This absolute distance may be used by the BSS to prevent MS from grossly exceeding the planned cell boundaries.

The allowable distance is administered on a cell by cell basis by the network operator.

9 Control parameters

A non-exhaustive list of parameters employed to control the radio links are shown in tables 1 and 2.

Table 1: Radio sub-system link control parameters

Parameter name	Description	Range	Bits	Channel
BSIC	Base Station Identification Code	0-63	6	SCH D/L
BA	BCCH Allocation	-	-	BCCH D/L
BA_IND	Sequence number of BA	0/1	1	BCCH D/L SACCH D/L
3G_BA_IND	Sequence number of 3G neighbour cell list and/or E-UTRAN neighbour cell list	0/1	1	BCCH D/L SACCH D/L
SI 23_3G_BA_IND	Sequence number of 3G neighbour cell list and/or E-UTRAN neighbour cell list (see note 4)	0/1	1	BCCH D/L
MS_TXPWR_MAX_CCH	The maximum TX power level an MS is allowed to use when accessing the system until otherwise commanded.	0/31	5	BCCH D/L
LB_MS_TXPWR_MAX_CCH	The maximum TX power level an MS is allowed to use on all other than DCS 1800 and PCS 1900 frequency bands when accessing the system until otherwise commanded. 0 = 43 dBm, 1 = 41 dBm, 2 = 39 dBm, ..., 18 = 7 dBm, 19 = 5 dBm, 20 = 5 dBm, ..., 31 = 5 dBm.	0-31	5	BCCH D/L
POWER OFFSET	The power offset will be used in conjunction with the MS TXPWR MAX CCH parameter by the class 3 DCS 1 800 MS: 0 = 0 dB 1 = 2 dB 2 = 4 dB 3 = 6 dB	0-3	2	BCCH D/L
RXLEV_ACCESS_MIN	Minimum received signal level at the MS required for access to the system.	0-63	6	BCCH D/L
RADIO_LINK_TIMEOUT	The maximum value of the radio link counter 4-64 SACCH blocks, 15 steps of 4 SACCH blocks	-	4	BCCH D/L SACCH D/L
CELL_RESELECT_HYSTERESIS	RXLEV hysteresis for required cell re-selection. 0-14 dB, 2 dB steps, i.e. 0 = 0 dB, 1 = 2 dB, etc.	0-7	3	BCCH D/L
NCC_PERMITTED	Bit map of NCCs for which the MS is permitted to report measurement results. Bit map relates to NCC part of BSIC.	-	8	BCCH D/L SACCH D/L
CELL_BAR_ACCESS	See table 1a.	0/1	1	BCCH D/L
CELL_BAR_QUALIFY	See table 1a.	0/1	1	BCCH D/L
CELL_BAR_QUALIFY_3	See tables 1b and 1c.	0-3	2	BCCH D/L
CELL_RESELECT_OFFSET	Applies an offset to the C2 reselection criterion. 0 - 126 dB, 2 dB steps, i.e. 0 = 0 dB, 1 = 2 dB, etc.	0-63	6	BCCH D/L
TEMPORARY_OFFSET	Applies a negative offset to C2 for the duration of PENALTY_TIME. 0 - 60 dB, 10 dB steps i.e. 0 = 0 dB, 1 = 10 dB, etc. and 7 = infinity	0-7	3	BCCH D/L
PENALTY_TIME	Gives the duration for which the temporary offset is applied. 20 to 620 s, 20 s steps, i.e. 0 = 20 s, 1 = 40 s, etc. 31 is reserved to indicate that CELL_RESELECT_OFFSET is subtracted from C2 and TEMPORARY_OFFSET is ignored.	0-31	5	BCCH D/L
LSA_OFFSET	Applies an offset to be used for LSA cell re-selection between cells with the same LSA priorities. 0 = 0 dB, 1 = 4 dB, 2 = 8 dB, 3 = 16 dB, 4 = 24 dB, 5 = 32 dB, 6 = 48 dB, 7 = 64 dB	0-7	3	BCCH D/L

continued

Parameter name	Description	Range	Bits	Channel
PRIO_THR	The PRIO signal strength threshold is related to RXLEV_ACCESS_MIN. 0 = 0 dB, 1 = 6 dB, 2 = 12 dB, 3 = 18 dB 4 = 24 dB, 5 = 30 dB, 6 = 36 dB, 7 = ∞ dB	0-7	3	BCCH D/L
LSA ID	The LSA identities for the cell			BCCH D/L
Qsearch_I	Search for UTRAN FDD cells if signal level is below (0-7) or above (8-15) threshold 0 = -98 dBm, 1 = -94 dBm, ... , 6 = -74 dBm, 7 = ∞ (always) 8 = -78 dBm, 9 = -74 dBm, ... , 14 = -54 dBm, 15 = ∞ (never). Default value = ∞ (never). Search for UTRAN TDD cells if signal level is below (0-7) or above (8-15) threshold 0 = -98 dBm, 1 = -94 dBm, ... , 6 = -74 dBm, 7 = ∞ (always) 8 = -90 dBm, 9 = -86 dBm, ... , 14 = -66 dBm, 15 = ∞ (never). Default value = ∞ (never).	0-15	4	BCCH D/L
Qsearch_C_Initial	Indicates the Qsearch value to be used in connected mode before Qsearch_C is received, 0 = use Qsearch_I, 1 = ∞ (always). Default value = use Qsearch_I.	0/1	1	BCCH D/L
FDD_Qoffset	Applies an offset to RLA_C for UTRAN FDD cell re-selection. 0 = -∞ (always select a cell if acceptable), 1 = -28 dB, 2 = -24 dB, ... , 15 = 28 dB. Default value = 0 dB.	0-15	4	BCCH D/L
TDD_Qoffset	An absolute threshold of RSCP for UTRAN TDD cell re-selection, 0 = -105dBm, 1 = -102dBm, 2=-99dBm, 3 = -96dBm, 4 = -93dBm, 5 = -90dBm, 6 = -87dBm, 7 = -84dBm, 8 = -81dBm, 9 = -78dBm, 10 = -75dBm, 11 = -72dBm, 12 = -69dBm, 13 = -66dBm, 14 = -63dBm, 15 = -60dBm. Default value = -90dBm.	0-15	4	BCCH D/L
FDD_Qmin	A minimum threshold for Ec/No for UTRAN FDD cell re-selection, 0= -20dB, 1= -6dB, 2= -18dB, 3= -8dB, 4= -16dB, 5= -10dB, 6= -14dB, 7= -12dB. Default value= -12dB.	0-7	3	BCCH D/L
FDD_Qmin_Offset	Applies an offset to FDD_Qmin value, 0 = 0 dB, 1 = 2 dB, 2 = 4 dB, 3 = 6 dB, 4 = 8 dB, 5 = 10 dB, 6 = 12 dB, 7 = 14 dB. Default value = 0 dB.	0-7	3	BCCH D/L
FDD_RSCPmin	A minimum threshold of RSCP for UTRAN FDD cell re-selection, 0 = -114 dBm, 1 = -112 dBm, 2 = -110 dBm, 3 = -108 dBm, 4 = -106 dBm, 5 = -104 dBm, 6 = -102 dBm, 7 = -100 dBm, 8 = -98 dBm, 9 = -96 dBm, 10 = -94 dBm, 11 = -92 dBm, 12 = -90 dBm, 13 = -88 dBm, 14 = -86 dBm, 15 = -84 dBm. Default value = -102 dBm.	0-15	4	BCCH D/L
THRESH_GSM_low	A threshold below which the MS is allowed to reselect to lower priority layers, 0 = 0 dB, 1 = 2 dB, 2 = 4 dB, ... , 13 = 26 dB, 14 = 28 dB, 15 = ∞ (always).	0-15	4	BCCH D/L
THRESH_priority_search	A threshold for the serving cell that controls measurement of inter-RAT cells or frequencies of lower priority when the priority-based cell reselection algorithm is used, 0 = -98 dBm, 1 = -95 dBm, 2 = -92 dBm, ... , 13 = -59 dBm, 14 = -56 dBm, 15 = ∞ (always).	0-15	4	BCCH D/L
GERAN_PRIORITY	Priority of GSM cells, 0 = lowest priority, ... , 7 = highest priority.	0-7	3	BCCH D/L
UTRAN_QRXLEVMIN	Minimum required RX level for cells on the target	0-31	5	BCCH D/L

	UTRAN frequency (dBm), 0 = -119 dBm, 1 = -117 dBm, 2 = -115 dBm, ..., 30 = -59 dBm, 31 = -57 dBm. Default value = -119 dBm.			
<i>continued</i>				

Parameter name	Description	Range	Bits	Channel
THRESH_UTRAN_high, THRESH_UTRAN_low	Reselection thresholds towards UTRAN FDD or TDD cells, 0 = 0 dB, 1 = 2 dB, 2 = 4 dB, 3 = 6 dB, ..., 30 = 60 dB, 31 = 62 dB. Default value of THRESH_UTRAN_low = value of THRESH_UTRAN_high.	0-31	5	BCCH D/L
UTRAN_PRIORITY	Priority of a UTRAN frequency layer, 0 = lowest priority, ..., 7 = highest priority.	0-7	3	BCCH D/L
E-UTRAN_QRXLEVMIN	Minimum required RX level for cells on the target E-UTRAN frequency (dBm), 0 = -140 dBm, 1 = -138 dBm, 2 = -136 dBm, ..., 30 = -80 dBm, 31 = -78 dBm. Default value = -140 dBm.	0-31	5	BCCH D/L
THRESH_E-UTRAN_high, THRESH_E-UTRAN_low	Reselection thresholds towards E-UTRAN FDD or TDD cells, 0 = 0 dB, 1 = 2 dB, 2 = 4 dB, 3 = 6 dB, ..., 30 = 60 dB, 31 = 62 dB. Default value of THRESH_E-UTRAN_low = value of THRESH_E-UTRAN_high.	0-31	5	BCCH D/L
E-UTRAN_PRIORITY	Priority of a E-UTRAN frequency layer, 0 = lowest priority, ..., 7 = highest priority.	0-7	3	BCCH D/L
H_PRIO	Hysteresis used in the priority reselection algorithm, 0 = ∞ (rule disabled), 1 = 5 dB, 2 = 4 dB, 3 = 3 dB.	0-3	2	BCCH D/L
T_reselection	Time hysteresis in the reselection algorithm, 0 = 5 sec, 1 = 10 sec, 2 = 15 sec, 3 = 20 sec. Default value = 0 (5 sec)	0-3	2	BCCH D/L
Qsearch_C_E-UTRAN_Initial	Indicates the Qsearch value to be used in dedicated / dual transfer mode before Qsearch_C_E-UTRAN is received, Search for E-UTRAN cells if signal level below threshold (0-7): - 98, - 94, ..., - 74 dBm, ∞ (always) or above threshold (8-15): - 78, - 74, ..., - 54 dBm, ∞ (never)	0-15	4	BCCH D/L
E-UTRAN_Qmin	Minimum required quality for cells on the target E-UTRAN frequency (dB), 0 = -34dB, 1 = -32dB, 2 = -30dB, ..., 14 = -6dB, 15 = -4dB. Default value = -34dB.	0-15	4	BCCH D/L
E-UTRAN_RSRPmin	Minimum required RX level for cells on the target E-UTRAN frequency (dBm), 0 = -140 dBm, 1 = -138 dBm, 2 = -136 dBm, ..., 30 = -80 dBm, 31 = -78 dBm. Default value = -140 dBm.	0-31	5	BCCH D/L
E-UTRAN_QQUALMIN	Minimum required quality for cells on the target E-UTRAN frequency (dB), 0 = -34dB, 1 = -32dB, 2 = -30dB, ..., 14 = -6dB, 15 = -4dB. Default value = -34dB.	0-15	4	BCCH D/L
THRESH_E-UTRAN_high_Q, THRESH_E-UTRAN_low_Q	Reselection thresholds towards E-UTRAN FDD or TDD cells, 0 = 0 dB, 1 = 1 dB, 2 = 2 dB, 3 = 3 dB, ..., 30 = 30 dB, 31 = 31 dB. Default value of THRESH_E-UTRAN_low_Q = value of THRESH_E-UTRAN_high_Q.	0-31	5	BCCH D/L

Table 1a: Parameters affecting cell priority for cell selection for A/Gb mode only capable mobile station.

CBQ3	CBQ	CBA	Cell selection priority	Status for cell reselection
XX	0	0	Normal (<i>A/Gb mode</i>)	Normal (<i>A/Gb mode</i>)
XX	0	1	Barred (<i>A/Gb mode</i>)	Barred (<i>A/Gb mode</i>)
XX	1	0	Low (<i>A/Gb mode</i>)	Normal (<i>A/Gb mode</i>) (see note 2)
XX	1	1	Low (<i>A/Gb mode</i>)	Normal (<i>A/Gb mode</i>) (see note 2)

Table 1b: Parameters affecting cell priority for cell selection for a mobile station supporting both A/Gb and *lu* modes.

CBQ3	CBQ	CBA	Cell selection priority	Status for cell reselection
00	0	0	Normal (<i>A/Gb mode</i>) (see note 4)	Normal (<i>A/Gb mode</i>) (see note 4)
00	0	1	Barred (<i>A/Gb and lu modes</i>) (see note 4)	Barred (<i>A/Gb and lu modes</i>) (see note 4)
00	1	0	Low (<i>A/Gb mode</i>) (see note 4)	Normal (<i>A/Gb mode</i>) (see notes 2 and 4)
00	1	1	Low (<i>A/Gb mode</i>) (see note 4)	Normal (<i>A/Gb mode</i>) (see notes 2 and 4)
01	X	X	Barred (<i>A/Gb and lu modes</i>) (see note 5)	Barred (<i>A/Gb and lu modes</i>) (see note 5)
10	X	X	Normal (<i>lu mode</i>) (see note 6)	Normal (<i>lu mode</i>) (see note 6)
11	X	X	Normal (<i>lu mode</i>) (see note 6)	Normal (<i>lu mode</i>) (see note 6)

Table 1c: Parameters affecting cell priority for cell selection for *lu* mode only capable mobile station.

CBQ3	CBQ	CBA	Cell selection priority	Status for cell reselection
00	X	X	Barred (<i>lu mode</i>) (see note 4)	Barred (<i>lu mode</i>) (see note 4)
01	X	X	Barred (<i>lu mode</i>) (see note 5)	Barred (<i>lu mode</i>) (see note 5)
10	X	X	Normal (<i>lu mode</i>) (see note 6)	Normal (<i>lu mode</i>) (see note 6)
11	X	X	Normal (<i>lu mode</i>) (see note 6)	Normal (<i>lu mode</i>) (see note 6)

For an *lu mode* capable MS, if all the following conditions are met, then the "Cell selection priority" and the "Status for cell reselection" shall be set to normal (*lu mode*):

- the cell belongs to the MS HPLMN if no EHPLMN list is available or is empty, or the cell belongs to any PLMN defined in the EHPLMN list;
- the MS is in cell test operation mode;
- the CELL_BAR_QUALIFY_3 is set to "01";
- the Access Control class 15 is barred;

Otherwise, if the MS is *A/Gb mode* capable, if all the following conditions are met, then the "Cell selection priority" and the "Status for cell reselection" shall be set to normal (*A/Gb mode*):

- the cell belongs to the MS HPLMN if no EHPLMN list is available or is empty, or the cell belongs to any PLMN defined in the EHPLMN list;
- the MS is in cell test operation mode;
- the CELL_BAR_ACCESS is set to "1";
- the CELL_BAR_QUALIFY is set to "0";
- the Access Control class 15 is barred.

NOTE 1: A low priority cell is only selected if there are no suitable cells of normal priority (see 3GPP TS 43.022).

- NOTE 2: Two identical semantics are used for cross phase compatibility reasons. This allows an operator to declare a cell always as a low priority one for a phase 2 MS, but keeps the opportunity for an operator to decide whether a phase 1 MS is permitted to camp on such a cell or not.
- NOTE 3: void
- NOTE 4: *Iu mode* not supported.
- NOTE 5: The cell is barred against the MSs supporting *Iu mode*.
- NOTE 6: *Iu mode* supported and the *Iu mode* capable MS shall access *Iu mode*.
- NOTE 7: In case an optional parameter is not included in a point-to-point signalling message, the default value of that parameter shall replace any previously broadcast value, where applicable.

Table 2: Handover and power control parameters – BCCH and slow ACCH

Parameter name	Description	Range	Bits	Message
MS_TXPWR_REQUEST (ordered MS power level)	The power level to be used by an MS	0-31	5	L1 header downlink
MS_TXPWR_CONF. (actual MS power level)	Indication of the power level in use by the MS.	0-31	5	L1 header uplink
POWER_LEVEL	The power level to be used by an MS on the indicated channel	0-31	5	HO/assignment command
RXLEV_FULL_SERVING_CELL	The RXLEV in the current serving cell accessed over all TDMA frames	0-63	6	Measurement results
RXLEV_SUB_SERVING_CELL	The RXLEV in the current serving cell accessed over a subset of TDMA frames	0-63	6	Measurement results
RXQUAL_FULL_SERVING_CELL	The RXQUAL in the current serving cell, assessed over all TDMA frames.	0-7	3	Measurement results
RXQUAL_SUB_SERVING_CELL	The RXQUAL in the current serving a cell, assessed over subset of TDMA frames.	0-7	3	Measurement results
DTX_USED	Indicates whether or not the MS used DTX during the previous measurement period.	-	1	Measurement results
BA_USED	Value of BA_IND for BCCH allocation used	0/1	1	Measurement results
3G_BA_USED	Value of 3G_BA_IND for the 3G neighbour cell list and/or E-UTRAN neighbour cell list	0/1	1	Measurement results
SI23_3G_BA_USED	Value of SI23_3G_BA_IND for the 3G neighbour cell list and/or E-UTRAN neighbour cell list (see note 5)	0/1	1	Measurement results
RXLEV_NCELL_(1-6)	The RXLEV assessed on BCCH carrier as indicated in the BCCH Allocation	0-63	6	Measurement results
BCCH_FREQ_NCELL_(1-6)	The BCCH carrier RF channel number in NCELL.	0-31	5	Measurement results
BSIC_NCELL_(1-6)	Base station identification code for NCELL.	0-63	6	Measurement results
MULTIBAND_REPORTING	Indication of the number of cells to be reported for each band in multiband operation.	0-3	2	BCCH D/L SACCH D/L
SCALE	Indication of the offset, which applies for the reported RXLEV values. 0 = 0 dB, 1 = +10 dB	0-1	1	Enhanced Measurement Report
SCALE_ORD	Indication of the offset, which shall be used for the reported RXLEV values. 0 = +0 dB, 1 = + 10 dB, 2 = automatic Default value = 0 dB.	0-2	2	SACCH D/L
Qsearch_C	Search for UTRAN FDD cells if signal level below threshold (0-7): - 98, - 94, ... , - 74 dBm, ∞ (always) or above threshold (8-15): - 78, - 74, ... , - 54 dBm, ∞ (never) Search for UTRAN TDD cells if signal level below threshold (0-7): - 98, - 94, ... , - 74 dBm, ∞ (always) or above threshold (8-15): - 90, - 86, ... , -66 dBm, ∞ (never)	0-15	4	SACCH D/L
REPORT_TYPE	Indicates which report type the MS shall use, 0 = enhanced, 1 = normal Default value = normal	0/1	1	BCCH D/L SACCH D/L
XXX_MULTIRAT_REPORTING	The number of cells from the access technology/mode XXX (one or more) that shall be included in the list of	0-3	2	BCCH D/L SACCH D/L

	strongest cells or in the measurement report.			
SERVING_BAND_REPORTING	The number of cells from the GSM serving frequency band that shall be included in the list of strongest cells or in the measurement report. Default value = 3	0-3	2	BCCH D/L SACCH D/L
<i>continued</i>				

Parameter name	Description	Range	Bits	Message
REP_PRIORITY	Indicates the reporting priority per cell, 0 = normal, 1 = high Default value = normal	0/1	1	SACCH D/L
REPORTING_RATE	Indicates the allowed reporting rate, 0 = normal, 1 = reduced. Default value = normal.	0/1	1	SACCH D/L
INVALID_BSIC_REPORTING	Indicates if GSM cells with invalid BSIC and allowed NCC part may be reported, 0 = no, 1 = yes. Default value = no.	0/1	1	SACCH D/L
XXX_REPORTING_THRESHOLD	Apply priority reporting if the reported value is above threshold for GSM frequency band or access technology/mode XXX (one or more), 0, 6, ..., 36, ∞ (never). Default value = always.	0-7	3	BCCH D/L SACCH D/L
FDD_REPORTING_THRESHOLD_2	Reporting threshold for the CPICH parameter (Ec/No or RSCP) that is not reported according to FDD_REP_QUANT. Default value = 0 (disabled)	0-63	6	BCCH/D/L SACCH D/L
XXX_REPORTING_OFFSET	Apply an offset to the reported value when prioritising the cells for reporting for GSM frequency band or access technology/mode XXX (one or more), 0, 6, ..., 42. Default value = 0.	0-7	3	BCCH D/L SACCH D/L
FDD_REP_QUANT	Indicates the reporting quantity for UTRAN FDD cells, 0 = RSCP, 1 = Ec/No	0/1	1	BCCH D/L SACCH D/L
RTD	The real time difference to other GSM cells, modulo 51 TDMA frames, step: 1 or 1/64 TDMA frame	0-50 or 0-3263	6 or 12	SACCH D/L
E-UTRAN_REP_QUANT	Indicates the reporting quantity for E-UTRAN cells, 0 = RSRP, 1 = RSRQ	0/1	1	BCCH D/L SACCH D/L
E-UTRAN_FDD_REPORTING_THRESHOLD_2	Reporting threshold for the parameter (RSRP or RSRQ) that is not reported according to E-UTRAN_REP_QUANT. Default value = 0 (disabled)	0-63	6	BCCH/D/L SACCH D/L
E-UTRAN_TDD_REPORTING_THRESHOLD_2	Reporting threshold for the parameter (RSRP or RSRQ) that is not reported according to E-UTRAN_REP_QUANT. Default value = 0 (disabled)	0-63	6	BCCH/D/L SACCH D/L
E-UTRAN_FDD_MEASUREMENT_REPORT_OFFSET	Apply measurement reporting if the measured value is above the parameter, which is also used in the calculation of the value of the quantity (RSRP or RSRQ) that is reported according to E-UTRAN_REP_QUANT, when 3-bit reporting is used.	0-63	6	BCCH/D/L SACCH D/L

	For RSRP the mapping is as follows: 0 = -140 dBm, 1 = -139 dBm, 2 = -138 dBm, ..., 62 = -78 dBm, 63 = -77 dBm. For RSRQ the mapping is as follows: 0 = -19.5 dB, 1 = -19 dB, 2 = -18.5 dB, ..., 31 = -4 dB, 32 = -3.5 dB, 33 = -3 dB. Default value = 0.			
E-UTRAN_TDD_MEASUREMENT_REPORT_OFFSET	Apply measurement reporting if the measured value is above the parameter, which is also used in the calculation of the value of the quantity (RSRP or RSRQ) that is reported according to E-UTRAN_REP_QUANT, when 3-bit reporting is used. For RSRP the mapping is as follows: 0 = -140 dBm, 1 = -139 dBm, 2 = -138 dBm, ..., 62 = -78 dBm, 63 = -77 dBm. For RSRQ the mapping is as follows: 0 = -19.5 dB, 1 = -19 dB, 2 = -18.5 dB, ..., 31 = -4 dB, 32 = -3.5 dB, 33 = -3 dB. Default value = 0.	0-63	6	BCCH/D/L SACCH D/L
REPORTING_GRANULARITY	Signals whether fine or coarse granularity is used in 3-bit reporting. For RSRP: 0 = 2 dB step size, 1 = 3 dB step size; for RSRQ: 0 = 1 dB step size, 1 = 2 dB step size). Default value = 0.	0/1	1	BCCH/D/L SACCH D/L
Qsearch_C_E-UTRAN	Search for E-UTRAN cells if signal level below threshold (0-7): - 98, - 94, ... , - 74 dBm, ∞ (always) or above threshold (8-15): - 78, - 74, ... , - 54 dBm, ∞ (never)	0-15	4	SACCH D/L
Measurement_Control_E-UTRAN	Frequency-specific search enabled 0 = never search 1 = use Qsearch_C_E-UTRAN if received, otherwise use Qsearch_C_E-UTRAN_Initial, Default value = 1.	0/1	1	SACCH D/L
Measurement_Control_UTRAN	Frequency-specific search enabled 0 = never search 1 = use Qsearch_C if received, otherwise use Qsearch_C_Initial, Default value = 1.	0/1	1	SACCH D/L
UTRAN_CSG_FDD_REPORTING_THRESHOLD	Reporting threshold for the reported value (Ec/No) for UTRAN FDD CSG cells, 0, 6, ... , 36, ∞ (never). Default value = same as the value of FDD_REPORTING_THRESHOLD if signalled and if FDD_REP_QUANT = 1; otherwise 4 (-12.5 dB ≤ CPICH Ec/No < -12 dB).	0-7	3	BCCH/D/L SACCH D/L
UTRAN_CSG_FDD_REPORTING_THRESHOLD_2	Reporting threshold for the non-reported value (RSCP) for UTRAN FDD CSG cells, Default value = same as the value of FDD_REPORTING_THRESHOLD_2 if signalled and if FDD_REP_QUANT = 1; otherwise 6 (-110 dBm ≤ CPICH RSCP < -109 dBm).	0-63	6	BCCH/D/L SACCH D/L
UTRAN_CSG_TDD_REPORTING_THRESHOLD	Reporting threshold for the reported value (RSCP) for UTRAN TDD CSG	0-7	3	BCCH/D/L SACCH D/L

	cells, 0, 6, ... , 36, ∞ (never). Default value = same as the value of TDD_REPORTING_THRESHOLD if signalled; otherwise 0.			
E- UTRAN_CSG_FDD_REPORTING_TH RESHOLD	Reporting threshold for the reported value (RSRQ) for E-UTRAN FDD CSG cells, 0, 6, ... , 36, ∞ (never). Default value = same as the value of E- UTRAN_FDD_REPORTING_THRES HOLD if signalled and if E- UTRAN_REP_QUANT = 1; otherwise 3 (-11.0 dB ≤ RSRQ < -10.5 dB).	0-7	3	BCCH/D/L
E- UTRAN_CSG_FDD_REPORTING_TH RESHOLD_2	Reporting threshold for the non- reported value (RSRP) for E-UTRAN FDD CSG cells. Default value = same as the value of E- UTRAN_FDD_REPORTING_THRES HOLD_2 if signalled and if E- UTRAN_REP_QUANT = 1; otherwise 11 (-120 dBm ≤ RSRP < -118 dBm).	0-63	6	BCCH/D/L
E- UTRAN_CSG_TDD_REPORTING_TH RESHOLD	Reporting threshold for the reported value (RSRQ) for E-UTRAN TDD CSG cells, 0, 6, ... , 36, ∞ (never). Default value = same as the value of E- UTRAN_TDD_REPORTING_THRES HOLD if signalled and if E- UTRAN_REP_QUANT = 1; otherwise 3 (-11.0 dB ≤ RSRQ < -10.5 dB).	0-7	3	BCCH/D/L
E- UTRAN_CSG_TDD_REPORTING_TH RESHOLD_2	Reporting threshold for the non- reported value (RSRP) for E-UTRAN TDD CSG cells, Default value = same as the value of E- UTRAN_TDD_REPORTING_THRES HOLD_2 if signalled and if E- UTRAN_REP_QUANT = 1; otherwise 11 (-120 dBm ≤ RSRP < -118 dBm).	0-63	6	BCCH/D/L
NOTE 1: RXLEV and RXQUAL fields are coded as described in clause 8.				
NOTE 2: BCCH_FREQ_NCELL_(1-6) is coded in accordance with 3GPP TS 44.018 as the position in the list of BA carriers.				
NOTE 3: For the details of the Measurement Result message see 3GPP TS 44.018.				
NOTE 4: SI_23_3G_BA_IND is applicable when network sharing is supported in a given cell and for a mobile station supporting network sharing, see 3GPP TS 44.018.				
NOTE 5: SI23_3G_BA_USED is related to network sharing, see 3GPP TS 44.018.				

10 GPRS mode tasks

10.1 Cell Re-selection

In *A/Gb mode*, in GMM Standby and GMM Ready states, cell re-selection is performed by the MS, except when the MS has an ongoing circuit switched connection (e.g. while in dual transfer mode), in which case the cell is determined by the network according to the handover procedures (see subclause 3). When the circuit switched connection is released, the MS shall resume cell re-selection (see subclause 6.7.1).

In *Iu mode*, in RRC-Idle and RRC-Connected modes, cell re-selection is performed by the MS, except while in RRC-Cell_Dedicated state, in which case the cell is determined by the network according to the handover procedures (see subclause 3). When the MS leaves the RRC-Cell_Dedicated state, the MS shall resume cell re-selection (see subclause 6.7.1).

The cell re-selection procedures defined in subclauses 10.1.1 to 10.1.3 apply in *A/Gb mode* to the MSs attached to GPRS if a PBCCH exists in the serving cell (See sub-clause 1.4). In *Iu mode* these procedures apply always.

In *A/Gb mode*, if PBCCH does not exist, the criteria and algorithms defined in subclauses 10.1.2 and 10.1.3 shall also apply if one or more cells are provided to the MS in a Packet Cell Change Order or Packet Measurement Order message (3GPP TS 44.060). In this case, the MS shall convert the idle mode cell re-selection parameters, received for the other cells according to clause 6, to GPRS cell re-selection parameters according to table 3a and use the same procedures, except that the MS may measure received signal strength in packet idle mode according to either subclause 6.6.1 or subclause 10.1.1.

Otherwise the MS shall perform cell re-selection according to the idle mode procedures defined in clause 6, except that the MS is only required to monitor full system information on BCCH of the serving cell if indicated by change mark on BCCH or PACCH. If PBCCH exists, the MS is not required to monitor system information on BCCH of the serving cell or any system information of the non-serving cells and only required to monitor system information on PBCCH of the serving cell if indicated by change mark on PBCCH, PCCH or PACCH.

For both cases (with or without PBCCH), the details of system information monitoring are specified in 3GPP TS 44.060 and 3GPP TS 44.160.

In packet transfer mode, broadcast/multicast receive mode or MAC-Shared state, the MS shall always measure received signal strength according to subclause 10.1.1.

The cells to be monitored for cell re-selection are defined in the BA(GPRS) list, which is broadcast on PBCCH. If PBCCH does not exist, BA(GPRS) is equal to BA(BCCH).

In addition, the network may control the cell selection as defined in subclause 10.1.4.

For a multi-RAT MS, cell re-selection to other radio access technologies shall also be possible. If PBCCH exists, the procedures in subclause 10.1.1.3, 10.1.3.2 and 10.1.3.3 shall apply. In *A/Gb mode*, if PBCCH does not exist, the criteria and algorithms defined in subclauses 10.1.1.3, 10.1.3.2 and 10.1.3.3 shall also apply if GPRS cell re-selection parameters for one or more cells are provided to the MS in a Packet Cell Change Order or Packet Measurement Order message; otherwise the idle mode procedures in subclause 6 shall apply.

10.1.1 Monitoring the received signal level and PBCCH data

The MS shall measure the received RF signal level on the BCCH carriers of the serving cell and the surrounding cells as indicated in the BA(GPRS) list and optionally the NC_FREQUENCY_LIST, and calculate the received level average (RLA_P) for each carrier.

In addition the MS shall verify the BSIC of the BCCH carriers. Only cells with allowed BSIC shall be considered for re-selection. The allowed BSIC is either a valid BSIC or, for cells in BA(BCCH) where no BSIC is broadcast, a BSIC with allowed NCC part (see subclause 7.2). A valid BSIC is a BSIC broadcast for that carrier in the BA(GPRS) list. For an MS supporting network sharing, a valid BSIC is a BSIC broadcast for that carrier in the BA(GPRS) list with a permitted NCC part (see subclause 7.2).

In addition to what is described in subclauses 10.1.1.1 and 10.1.1.2, an MS supporting SoLSA with SoLSA subscription shall attempt to decode BSIC for the 6 strongest carriers, with LSA IDs to which the MS subscribes. At least one carrier shall be searched every 5 minutes, one after another. In the case the MS has been able to decode the BSIC, the rules described in 10.1.3 shall be followed. The LSA IDs of the carriers are broadcast on PBCCH of the serving cell.

10.1.1.1 Packet idle mode or MAC-Idle state

Whilst in packet idle mode or MAC-Idle state an MS shall continuously monitor all BCCH carriers as indicated by the BA(GPRS) list and the BCCH carrier of the serving cell. At least one received signal level measurement sample on each BCCH carrier shall be taken for each paging block monitored by the MS according to its current DRX mode and its paging group. As the minimum MS shall take one measurement for each BCCH carrier for every 4 second. As the maximum, the MS is however not required to take more than 1 sample per second for each BCCH carrier.

RLA_P shall be a running average determined using samples collected over a period of 5 s to Max {5s, five consecutive paging blocks of that MS}, and shall be maintained for each BCCH carrier. The same number of measurement samples shall be taken for all BCCH carriers, and the samples allocated to each carrier shall as far as possible be uniformly distributed over the evaluation period. At least 5 received signal level measurement samples are required for a valid RLA_P value.

The list of the 6 strongest non-serving carriers shall be updated at a rate of at least once per running average period.

The MS shall attempt to check the BSIC for each of the 6 strongest non-serving cell BCCH carriers at least every 14 consecutive paging blocks of that MS or 10 seconds, whichever is greater. If a change of BSIC is detected then the carrier shall be treated as a new carrier.

In the case of a multiband MS, the MS shall attempt to decode the BSIC, if any BCCH carrier with unknown BSIC is detected among the number of strongest BCCH carriers in each band as indicated by the parameter MULTIBAND_REPORTING (see subclause 8.4.3), broadcast on PBCCH, or if PBCCH does not exist, on BCCH.

When requested by the user, the MS shall determine which PLMNs are available as described in subclause 6.6.1. However, for MSs without DRX or with short DRX period (see 3GPP TS 45.002), considerable interruptions to the monitoring of PPCH or PCH can not be avoided.

When PBCCH is not present in the serving cell and the network controlled cell reselection mode (see subclause 10.1.4) is not set to NC2, the MS shall follow the procedures specified in section 6.6.1 for the acquisition and periodic verification of the parameters affecting cell reselection for the non-serving cells.

10.1.1.2 Packet transfer mode or MAC-Shared state

Whilst in packet transfer mode or MAC-Shared state an MS shall continuously monitor all BCCH carriers as indicated by the BA(GPRS) list and the BCCH carrier of the serving cell. In every TDMA frame, a received signal level measurement sample shall be taken on at least one of the BCCH carriers, one after the other. Optionally, measurements during up to 8 TDMA frames per PDCH multiframe may be omitted if required for BSIC decoding or multi-RAT measurements.

RLA_P shall be a running average determined using samples collected over a period of 5 s, and shall be maintained for each BCCH carrier. The same number of measurement samples shall be taken for all BCCH carriers except, if the parameter PC_MEAS_CHAN indicates that the power control measurements shall be made on BCCH (see subclause 10.2.3.1.2), for the serving cell where at least 6 measurement samples shall be taken per 52-multiframe. The samples allocated to each carrier shall as far as possible be uniformly distributed over the evaluation period. At least 5 received signal level measurement samples are required for a valid RLA_P value.

In some allowed multislot configurations (see 3GPP TS 45.002) the MS is not able to perform normal received signal level measurements within the TDMA frame. In this case, the MS shall perform the measurements whenever possible according to its measurement capability (see 3GPP TS 45.002). For downlink packet transfer using any medium access mode (see 3GPP TS 44.060), the MS shall perform the measurements during the block period where the polling response is sent (T_{ra} shall apply).

NOTE 1: The network is responsible for providing the necessary opportunities to ensure that the MS will perform the required number of measurements.

The MS shall attempt to check the BSIC for as many non-serving cell BCCH carriers as possible and as often as possible, and at least every 10 seconds. A multi-RAT MS is allowed to extend this period to 13 seconds, if the neighbour cell list contains cells or frequencies from other RATs. The MS shall use the two Idle frames of the PDCH multiframe for this purpose. These frames are termed "search" frames. A list containing BSIC and timing information for these strongest carriers at the accuracy required for accessing a cell (see 3GPP TS 45.010) including the absolute times derived from the parameters T1, T2, T3 shall be kept by the MS. This information may be used to schedule the decoding of BSIC and shall be used when re-selecting a new cell in order to keep the switching time at a minimum. When a BCCH carrier is found to be no longer among the reported, BSIC and timing information shall be retained for 10 seconds. (This is in case a cell re-selection command to this cell is received just after the MS has stopped reporting that cell, see subclause 10.1.4.2).

In some allowed multislot configurations (see 3GPP TS 45.002) the MS is not able to perform BSIC decoding or multi-RAT measurements. In this case, except when the MS performs FCCH search or when the SCH burst falls into the available search window, the MS may:

- (a) either skip the last transmission burst in the frame immediately preceding the idle frame;
- (b) or skip the first reception burst in the frame immediately following the idle frame;
- (c) or delay the transmission of an (E)GPRS RLC/MAC block for data transfer occurring in the radio block period whose last timeslot allocated for such block immediately precedes the idle frame to next available uplink radio block period and in this case the MS may not perform transmission on that timeslot in the block period;

in order to comply to the requirement to verify and decode BSIC information, or in order to perform multi-RAT measurements.

If, after averaging measurement results over 4 PDCH multiframes (1 sec), the MS detects one or more BCCH carriers, among the 6 strongest, whose BSICs are not currently being assessed, then the MS shall as a matter of priority attempt to decode their BSICs.

In the case of a multiband MS, the MS shall attempt to decode the BSIC, if any BCCH carrier with unknown BSIC is detected among the number of strongest BCCH carriers in each band as indicated by the parameter MULTIBAND_REPORTING (see subclause 8.4.3), broadcast on PBCCH, or if PBCCH does not exist, on BCCH.

Thus an MS shall, for a period of up to 5 seconds, devote all search frames to attempting to decode these BSICs. If this fails then the MS shall return to confirming existing BSICs. Having re-confirmed existing BSICs, if there are still BCCH carriers, among the six strongest, with unknown BSICs, then the decoding of these shall again be given priority for a further period of up to 5 seconds.

The MS shall be able to send the first packet random access (PRACH) at the latest $5+x$ seconds after a new strongest cell (which is part of the BA(GPRS)) has been activated under the following network conditions: Initial serving cell at RXLEV= -70 dBm, with 6 neighbours at RXLEV= -75 dBm. Then the new BCCH carrier is switched on at RXLEV= -60 dBm. x is the longest time it may take to receive the necessary system information on PBCCH in the new cell.

Note: Because of test equipment limitations it is acceptable to activate the new carrier to replace one of the 6 neighbours.

If either no BSIC can be decoded on a surrounding cell BCCH carrier, or the BSIC is not allowed, then the received signal level measurements on that channel shall be discarded and the MS shall continue to monitor that channel.

If a change of BSIC is detected on a carrier, then any existing received signal level measurement shall be discarded and the carrier shall be treated as a new carrier.

If the BSIC cannot be decoded at the next available opportunities re-attempts shall be made to decode this BSIC. If the BSIC is not decoded for more than three successive attempts it will be considered lost and any existing received signal level measurement shall be discarded and the MS shall continue to monitor that carrier.

When PBCCH is not present in the serving cell and the network controlled cell reselection mode (see subclause 10.1.4) is not set to NC2, the MS shall follow the procedures specified in section 6.6.1 for the acquisition and periodic verification of the parameters affecting cell reselection for the non-serving cells.

10.1.1.2a Broadcast/multicast receive mode

Whilst in broadcast/multicast receive mode, an MS shall continuously monitor all BCCH carriers as indicated by the BA(GPRS) list and the BCCH carrier of the serving cell. In every TDMA frame, a received signal level measurement sample shall be taken on at least one of the BCCH carriers, one after the other. Optionally, measurements during up to 8 TDMA frames per PDCH multiframe may be omitted if required for BSIC decoding or multi-RAT measurements. Measurements may also be omitted in the TDMA frames where the MS is required to monitor a system information block or a paging block. For this task, minimum performance requirements as for packet idle mode shall apply (see subclause 10.1.1.1).

NOTE: It is expected that in all multislot configurations allowed for MBMS (see 3GPP TS 45.002) the MS is able to perform normal received signal level measurements within the TDMA frame. Hence, no interruption of the reception is required for this purpose.

The MS shall additionally attempt to check the BSIC for non-serving cell BCCH carriers and, in case of a multi-RAT MS, perform measurements on neighbour cells from other RATs using the search frames. For these tasks, performance requirements as for packet transfer mode shall apply (see subclause 10.1.1.2 and subclause 10.1.1.3).

When the PBCCH is not present in the serving cell, the MS shall not attempt to decode the BCCH data block that contains the parameters affecting cell reselection as described in section 6.6.1 for non-serving cells that have been provided by the System Information message received from the serving cell. Instead, this information shall be provided by the network on PACCH or on BCCH (see 3GPP TS 44.060 and 3GPP TS 44.018).

10.1.1.3 Monitoring cells of other radio access technologies

For a multi-RAT MS, cells or frequencies with other radio access technologies (excluding E-UTRA) may also be included in the GPRS 3G Cell Reselection list to be monitored (see 3GPP TS 44.060). This list may be modified by

Packet Measurement Order or Packet Cell Change Order messages (see 3GPP TS 44.060). If cell reselection based on ranking is used, the network controls the measurements for reselection of those cells by the parameter Q_{search_P} optionally broadcast on PBCCH or on BCCH if PBCCH does not exist. Q_{search_P} defines a threshold and also indicates whether these measurements shall be performed when RLA_P of the serving cell is below or above the threshold.

For a multi-RAT MS supporting E-UTRA, E-UTRA frequencies may be included in the E-UTRAN Neighbour Cell list to be monitored (see 3GPP TS 44.060). This list may be modified by the Packet Measurement Order message (see 3GPP TS 44.060). The network controls the measurements for reselection of E-UTRA cells by the parameter $THRESH_priority_search$ broadcast on BCCH. This parameter also controls measurement of inter-RAT cells or frequencies included in the GPRS 3G Cell Reselection list when the inter-RAT cell reselection algorithm based on priority information is used (see subclause 10.1.3.3). The mobile station shall monitor cells of inter-RAT frequencies of higher priority than the serving cell. When RLA_P of the serving cell is below $THRESH_priority_search$, the mobile station shall monitor cells of inter-RAT frequencies of lower priority than the serving cell. When RLA_P (see subclause 10.1.1.3) of the serving cell is above the threshold, the mobile station is allowed not to monitor cells of inter-RAT frequencies of lower priority than the serving cell.

For this monitoring, the MS may use search frames that are not required for BSIC decoding or interference measurements in packet transfer mode or MAC-Shared state. The MS may use up to 25 search frames per 13 seconds without considering the need for BSIC decoding or packet transfer mode / MAC-Shared state interference measurements in these frames.

Both valid cells as defined in subclause 8.4.7, and any identified cell on a frequency for which not full identification is included in the GPRS 3G Cell Reselection list, shall be considered for re-selection.

In packet transfer mode or MAC-Shared state, a UTRAN capable MS shall be able to send the first access at the latest $10+x$ seconds (in case of cell reselection based on cell ranking) or $5+T_{reselection}+x$ seconds (in case of cell reselection based on priority information, if the UTRAN frequency has lower priority than the serving cell and if RLA_P of the serving cell is below $THRESH_priority_search$) after a new best UTRAN cell, which is part of the GPRS 3G Cell Reselection list, has been activated under the condition that there is only one UTRAN frequency in the list (and no E-UTRAN frequencies in the E-UTRAN Neighbour Cell list) and that no new GSM cells are activated at the same time and under good radio conditions. x is the longest time it may take to receive the necessary system information in the new cell. As an exception, the time is increased to $65+T_{reselection}+x$ seconds in case of a UTRAN capable MS performing cell reselection based on priority information (see subclause 10.1.3.3) if the UTRAN frequency has higher priority than the serving cell. A E-UTRAN capable MS that supports autonomous cell reselection to E-UTRAN in packet transfer mode shall be able to send the first access at the latest $5+T_{reselection}+x$ seconds after a new best E-UTRAN cell on a frequency, which is part of the E-UTRAN Neighbour Cell list, has been activated if the frequency has lower priority than the serving cell and if RLA_P of the serving cell is below $THRESH_priority_search$, or within $65+T_{reselection}+x$ seconds after it has been activated if the frequency has higher priority than the serving cell, under the condition that there is only one E-UTRAN frequency in the list (and no UTRAN frequencies in the GPRS 3G Cell Reselection list) and that no new GSM cells are activated at the same time and under good radio conditions. For test purposes the following radio conditions can be used: Serving GSM cell at $RXLEV = -70$ dBm, with 6 GSM neighbours at $RXLEV = -75$ dBm. Then either an UTRAN FDD neighbour cell or an UTRAN TDD neighbour cell or an E-UTRAN FDD neighbour cell or an E-UTRAN TDD neighbour cell is switched on. The radio conditions for the UTRAN FDD cell are as follows (see 3GPP TS 25.101 for definitions):

Parameter	Unit	UTRAN FDD Cell
<i>CPICH_Ec/Ior</i>	dB	-10
<i>P-CCPCH_Ec/Ior</i>	dB	-12
<i>SCH_Ec/Ior</i>	dB	-12
<i>PICH_Ec/Ior</i>	dB	-15
<i>DPCH_Ec/Ior</i>	dB	$-\infty$
<i>OCNS_Ec/Ior</i>	dB	-0.94
\hat{I}_{or}/I_{oc}	dB	10
I_{oc}	dBm/3.84 MHz	-70
<i>CPICH_Ec/Io</i>	dB	-10.4
<i>CPICH RSCP</i>	dBm	-70
FDD_GPRS_Qoffset	integer	5 (-12dB)
FDD_Qmin	integer	7 (-12dB)
FDD_Qmin_Offset	integer	0 (0 dB)
FDD_RSCPmin	integer	6 (-102 dBm)
Qsearch_P	integer	7 (search always)
Propagation Condition	AWGN	

NOTE: The parameters in the table above are valid only for cell reselection based on cell ranking.

The radio conditions for the UTRAN TDD cell (either 3.84 Mcps TDD option or 1.28 Mcps TDD option) are as follows (see 3GPP TS 25.123 for definitions and for the values of the remaining configuration parameters):

Parameter	Unit	UTRAN TDD Cell (3.84 Mcps option)	
		0	8
<i>Timeslot Number</i>		0	8
<i>P-CCPCH_Ec/Ior</i>	dB	-3	
<i>SCH_Ec/Ior</i>	dB	-9	-9
<i>SCH_{t_offset}</i>	integer	0	0
<i>PICH_Ec/Ior</i>	dB		-3
<i>OCNS_Ec/Ior</i>	dB	-3.12	-3.12
<i>P-CCPCH RSCP</i>	dBm	-70	-70
TDD_Qoffset	integer	5 (-90dBm)	
Qsearch_P	integer	7 (search always)	
Propagation Condition	AWGN		

NOTE: On timeslot 8 the P-CCPCH is not transmitted; on that timeslot, the P-CCPCH RSCP defines the power level of the beacon channel.

NOTE: The parameters in the table above are valid only for cell reselection based on cell ranking.

Parameter	Unit	UTRAN TDD Cell (1.28 Mcps option)	
<i>Timeslot Number</i>		0	DwPTS
<i>P-CCPCH_{Ec/Ior}</i>	dB	-3	
<i>DwPCH_{Ec/Ior}</i>	dB		0
<i>OCNS_{Ec/Ior}</i>	dB	-3	
<i>P-CCPCH RSCP</i>	dBm	-70	
TDD_Qoffset	integer	5 (-90dBm)	
Qsearch_P	integer	7 (search always)	
Propagation Condition	AWGN		

NOTE: The parameters in the table above are valid only for cell reselection based on cell ranking.

The radio conditions for the E-UTRAN FDD cell are as follows (see 3GPP TS 36.101 for definitions):

Parameter	Unit	E-UTRAN FDD Cell
<i>Channel Bandwidth</i>	MHz	10
<i>PSS_{RB}, SSS_{RB}, PBCH_{RA}, PBCH_{RB}, PCFICH_{RA}, PHICH_{RA}, PHICH_{RB}, PDCCH_{RA}, PDCCH_{RB}, PDSCH_{RA}, PDSCH_{RB}</i>	dB	0
<i>OCNG_{RA}</i> (Note 1)	dB	0
<i>OCNG_{RB}</i> (Note 1)	dB	0
<i>RSRP</i>	dBm/15kHz	-86
\bar{E}_s/I_{ot}	dB	12
N_{oc}	dBm/15kHz	-98
E-UTRAN_QRXLEVMIN	integer	0 (-140 dBm)
THRESH_priority_search	integer	15 (search always)
T_reselection	integer	0 (5 s)
THRESH_E-UTRAN_high	integer	24 (48 dB)
E-UTRAN_PRIORITY	integer	higher than GERAN_PRIORITY
OCNG pattern	OP.2 FDD (see 3GPP TS 36.133)	
MIMO configuration	single transmitter	
Propagation Condition	AWGN	
NOTE 1: OCNG shall be used such that the E-UTRAN cell is fully allocated and a constant total transmitted power spectral density is achieved for all OFDM symbols.		

NOTE: The parameters in the table above are valid if THRESH_E-UTRAN_high_Q and THRESH_E-UTRAN_low_Q are not signalled.

The radio conditions for the E-UTRAN TDD cell are as follows (see 3GPP TS 36.101 for definitions):

Parameter	Unit	E-UTRAN TDD Cell
<i>Channel Bandwidth</i>	MHz	10
<i>PSS_RB, SSS_RB, PBCH_RA, PBCH_RB, PCFICH_RA, PHICH_RA, PHICH_RB, PDCCH_RA, PDCCH_RB, PDSCH_RA, PDSCH_RB</i>	dB	0
<i>OCNG_RA</i> (Note 1)	dB	0
<i>OCNG_RB</i> (Note 1)	dB	0
<i>RSRP</i>	dBm/15kHz	-86
\hat{E}_s/I_{ot}	dB	12
N_{oc}	dBm/15kHz	-98
E-UTRAN_QRXLEVMIN	integer	0 (-140 dBm)
THRESH_priority_search	integer	15 (search always)
T_reselection	integer	0 (5 s)
THRESH_E-UTRAN_high	integer	24 (48 dB)
E-UTRAN_PRIORITY	integer	higher than GERAN_PRIORITY
OCNG pattern	OP.2 TDD (see 3GPP TS 36.133)	
MIMO configuration	single transmitter	
Propagation Condition	AWGN	
NOTE 1: OCNG shall be used such that the E-UTRAN cell is fully allocated and a constant total transmitted power spectral density is achieved for all OFDM symbols.		

NOTE: The parameters in the table above are valid if THRESH_E-UTRAN_high_Q and THRESH_E-UTRAN_low_Q are not signalled.

The allowed access time is increased

- by 5 seconds for each additional UTRAN frequency in the GPRS 3G Cell Reselection list and by the time required for BSIC decoding of new activated GSM cells when the reselection algorithm based on ranking is used, or
- by 5 seconds for each additional UTRAN frequency of lower priority in the GPRS 3G Cell Reselection list when the reselection algorithm based on priority information is used or for each additional E-UTRAN frequency of lower priority in the E-UTRAN Neighbour Cell list and by the time required for BSIC decoding of new activated GSM cells under the condition that RLA_P of the serving cell is below THRESH_priority_search, or
- by 70 seconds for each additional UTRAN frequency of higher priority in the GPRS 3G Cell Reselection list when the reselection algorithm based on priority information is used or for each additional E-UTRAN frequency of higher priority in the E-UTRAN Neighbour Cell list and by the time required for BSIC decoding of new activated GSM cells.

However, multiple UTRAN cells on the same frequency in the GPRS 3G Cell Reselection list does not increase the allowed access time.

NOTE: The requirements above assume that only one of the frequencies in the GPRS 3G Cell Reselection list or in the E-UTRAN Neighbour Cell list is switched on.

In packet transfer mode or MAC-Shared state, for some allowed multislot configurations (see 3GPP TS 45.002), identification of a UTRAN TDD cell may not be guaranteed. In such cases, the MS may not be able to fulfil the requirement above. If after 5 seconds the MS has not been able to identify a UTRAN TDD cell, the MS is allowed to stop searching for it in the current GSM cell.

In packet idle mode or MAC-Idle state, a UTRAN capable MS shall be able to identify and select a new best UTRAN cell on a frequency, which is part of the GPRS 3G Cell Reselection list, within 30 seconds (in case of cell

reselection based on cell ranking) or $25+T_{\text{reselection}}$ seconds (in case of cell reselection based on priority information, if the UTRAN frequency has lower priority than the serving cell and if RLA_P of the serving cell is below $THRESH_priority_search$) after it has been activated under the condition that there is only one UTRAN frequency in the list (and no E-UTRAN frequencies in the E-UTRAN Neighbour Cell list) and that no new GSM cells are activated at the same time and under good radio conditions. As an exception, the time is increased to $70+T_{\text{reselection}}$ seconds in case of a UTRAN capable MS performing cell reselection based on priority information (see subclause 10.1.3.3) if the UTRAN frequency has higher priority than the serving cell. A E-UTRAN capable MS shall be able to identify and select a new best E-UTRAN cell on a frequency, which is part of the E-UTRAN Neighbour Cell list, within $25+T_{\text{reselection}}$ seconds after it has been activated if the frequency has lower priority than the serving cell and if RLA_P of the serving cell is below $THRESH_priority_search$, or within $70+T_{\text{reselection}}$ seconds after it has been activated if the frequency has higher priority than the serving cell under the condition that there is only one E-UTRAN frequency in the list (and no UTRAN frequencies in the GPRS 3G Cell Reselection list) and that no new GSM cells are activated at the same time and under good radio conditions. For test purposes the same radio conditions as for packet transfer can be used. The allowed time is increased

- by 30 seconds for each additional UTRAN frequency in the GPRS 3G Cell Reselection list when the reselection algorithm based on ranking is used, or
- by 30 seconds for each additional UTRAN frequency of lower priority in the GPRS 3G Cell Reselection list when the reselection algorithm based on priority information is used or for each additional E-UTRAN frequency of lower priority in the E-UTRAN Neighbour Cell list under the condition that RLA_P of the serving cell is below $THRESH_priority_search$, or
- by 70 seconds for each additional UTRAN frequency of higher priority in the GPRS 3G Cell Reselection list when the reselection algorithm based on priority information is used or for each additional E-UTRAN frequency of higher priority in the E-UTRAN Neighbour Cell list.

However, multiple UTRAN cells on the same frequency in the GPRS 3G Cell Reselection list does not increase the allowed time.

NOTE: The requirements above assume that only one of the frequencies in the GPRS 3G Cell Reselection list or in the E-UTRAN Neighbour Cell list is switched on.

A multi-RAT MS shall be able to monitor cells from other radio access technologies, divided into (depending on the MS capability):

- UTRAN FDD cells on up to 3 FDD frequencies, with a maximum of 32 cells per frequency; and/or
- UTRAN TDD cells on up to 3 TDD frequencies, with a maximum of 32 cells per frequency; and/or
- E-UTRAN FDD cells on up to 3 FDD frequencies; and/or
- E-UTRAN TDD cells on up to 3 TDD frequencies.

The total number of monitored UTRAN cells shall not exceed 64.

The MS shall be capable of performing RSCP and E_c/N_0 measurements of at least 4 best UTRAN cells per UTRAN frequency and RSRP and RSRQ measurements of at least 4 best E-UTRAN cells per E-UTRAN frequency, according to its supported capabilities.

In packet idle mode or MAC-Idle state, the MS shall attempt to read and store UTRAN predefined configurations as specified for idle mode in subclause 6.6.4.

10.1.2 Cell Re-selection Criteria

The following cell re-selection criteria are used for GPRS and *lu mode*, whereby (s) denotes the serving cell, and (n_i) denotes the neighbour cells. Different parameter values may apply for each neighbour cell. One set of parameters is broadcast in each cell.

- 1) The path loss criterion parameter C1 is used as a minimum signal level criterion for cell re-selection for GPRS and *lu mode* in the same way as for GSM Idle mode. C1 is the same as defined in subclause 6.4, except that

$$\begin{aligned} A &= RLA_P - GPRS_RXLEV_ACCESS_MIN \\ B &= GPRS_MS_TXPWR_MAX_CCH - P \end{aligned}$$

The parameters $GPRS_RXLEV_ACCESS_MIN$ and $GPRS_MS_TXPWR_MAX_CCH$ for the serving cell and neighbour cells are broadcast on PBCCH of the serving cell (POWER OFFSET is not used).

While these two parameters have not been received (because the PSI3 information element has not been decoded) default parameters shall be used to calculate C1.

While GPRS_RXLEV_ACCESS_MIN is not available, the MS shall use the RXLEV_ACCESS_MIN parameter.

While GPRS_MS_TXPWR_MAX_CCH is not available, the MS shall use the MS_TXPWR_MAX_CCH parameter.

All values are expressed in dBm.

- 2) The signal level threshold criterion parameter C31 for hierarchical cell structures (HCS) is used to determine whether prioritised hierarchical GPRS and LSA cell re-selection shall apply and is defined by:

$$\begin{aligned} C31(s) &= RLA_P(s) - HCS_THR(s) && \text{(serving cell)} \\ C31(n) &= RLA_P(n) - HCS_THR(n) - TO(n) * L(n) && \text{(neighbour cell)} \end{aligned}$$

where HCS_THR is the signal threshold for applying HCS GPRS and LSA re-selection. HCS_THR is broadcast on PBCCH of the serving cell. If HCS_THR(s) is not broadcast on PBCCH of the serving cell, HCS_THR(s) and HCS_THR(n) shall be assumed as infinity.

- 3) The cell ranking criterion parameter (C32) is used to select cells among those with the same priority and is defined by:

$$\begin{aligned} C32(s) &= C1(s) && \text{(serving cell)} \\ C32(n) &= C1(n) + GPRS_RESELECT_OFFSET(n) - TO(n) * (1-L(n)) && \text{(neighbour cell)} \end{aligned}$$

where

GPRS_RESELECT_OFFSET applies an offset and hysteresis value to each cell

$$TO(n) = GPRS_TEMPORARY_OFFSET(n) * H(GPRS_PENALTY_TIME(n) - T(n)).$$

$$L(n) = \begin{cases} 0 & \text{if } PRIORITY_CLASS(n) = PRIORITY_CLASS(s) \\ 1 & \text{if } PRIORITY_CLASS(n) \neq PRIORITY_CLASS(s) \end{cases}$$

In case PRIORITY_CLASS is undefined, L(n) = 0.

$$H(x) = \begin{cases} 0 & \text{for } x < 0 \\ 1 & \text{for } x \geq 0 \end{cases}$$

GPRS_TEMPORARY_OFFSET applies a negative offset to C31/C32 for the duration of GPRS_PENALTY_TIME after the timer T has started for that cell. T is defined in subclause 6.4.

GPRS_RESELECT_OFFSET, PRIORITY_CLASS, GPRS_TEMPORARY_OFFSET and GPRS_PENALTY_TIME are optionally broadcast on PBCCH of the serving cell. If GPRS_RESELECT_OFFSET, GPRS_TEMPORARY_OFFSET and GPRS_PENALTY_TIME are not broadcast on PBCCH of the serving cell, the MS shall use the default values defined in 3GPP TS 44.060.

10.1.3 Cell Re-selection Algorithm

At least for every new sample or every second, whichever is the greatest, the MS shall update RLA_P and calculate the value of C1, C31 and C32 for the serving cell and the non-serving cells. The MS shall make a cell re-selection if:

- i) The path loss criterion parameter (C1) for the serving cell falls below zero.
- ii) A non-serving suitable cell (see 3GPP TS 43.022) is evaluated to be better than the serving cell. The best cell is the cell with the highest value of C32 among
 - those cells that have the highest PRIORITY_CLASS among those cells that have highest LSA priority among those that fulfil the criterion $C31 \geq 0$, or
 - all cells, if no cells fulfil the criterion $C31 \geq 0$.

If the parameter C32_QUAL is set, positive GPRS_RESELECT_OFFSET values shall only be applied to the neighbour cell with the highest RLA_P value of those cells for which C32 is compared above.

LSA priority is defined by the list of LSAs for the subscriber stored on the SIM (see 3GPP TS 51.011). LSAs are identified by LSA ID(s) broadcast on PBCCH of the serving cell. Cells not belonging to this list are given LSA priority lower than 0. The LSA priority shall be considered only by an MS supporting SoLSA.

PRIORITY_CLASS and C32_QUAL are broadcast on PBCCH of the serving cell.

When evaluating the best cell, the following hysteresis values shall be subtracted from the C32 value for the neighbour cells:

- in GMM Standby state (*A/Gb mode*) or RRC-Idle mode or RRC-GRA_PCH state (*Iu mode*), if the new cell is in the same routing area: 0.
- in GMM Ready state (*A/Gb mode*) or RRC-Cell_Shared state (*Iu mode*), if the new cell is in the same routing area:
GPRS_CELL_RESELECT_HYSTERESIS. If the parameter C31_HYST is set, GPRS_CELL_RESELECT_HYSTERESIS shall also be subtracted from the C31 value for the neighbour cells.
- in GMM Standby or GMM Ready state (*A/Gb mode*) or RRC-Idle or RRC_Connected mode (*Iu mode*), if the new cell is in a different routing area:
RA_RESELECT_HYSTERESIS.
- in case of a cell re-selection occurred within the previous 15 seconds: 5 dB.

GPRS_CELL_RESELECT_HYSTERESIS, C31_HYST and RA_RESELECT_HYSTERESIS are broadcast on PBCCH of the serving cell.

Cell re-selection for any other reason (see 3GPP TS 43.022) shall take place immediately, but the cell that the MS was camped on shall not be returned to within 5 seconds if another suitable cell can be found. If valid RLA_P values are not available, the MS shall wait until these values are available and then perform the cell re-selection if it is still required. The MS may accelerate the measurement procedure within the requirements in subclause 10.1.1 to minimise the cell re-selection delay.

If no suitable cell is found within 10 seconds, the cell selection algorithm of 3GPP TS 43.022 shall be performed. Since information concerning a number of channels is already known to the MS, it may assign high priority to measurements on the strongest carriers from which it has not previously made attempts to obtain BCCH information, and omit repeated measurements on the known ones.

While in broadcast/multicast receive mode, the MS shall apply the rules defined above for the GMM Ready state.

10.1.3.1 Abnormal cell reselection

In the event of an abnormal release with cell reselection (see 3GPP TS 44.060) and 3GPP TS 44.160) the MS shall determine which cell to be used for this cell reselection attempt according to the following rules.

Within the allowed time, the MS shall attempt abnormal cell reselection on a suitable cell using one of the following two criteria:

- a) The MS shall try cells based on BA(GPRS), in the order of C2, starting from the cell with the highest C2 value according to section 6.6.2 item ii sub-item a, excluding the timing requirement of 5 seconds.
- b) The MS shall try cells based on BA(GPRS), in the order of C32, starting from the cell with the highest C32 value according to section 10.1.3 item ii.

The criteria, a) or b), to be used shall be determined by which cell reselection algorithm is currently in use according to section 10.1.

The MS is under no circumstances allowed to access a cell to attempt abnormal cell reselection later than 20 seconds after the detection within the MS of the abnormal release causing the abnormal cell reselection attempt. In the case where the 20 seconds elapses without a successful abnormal cell reselection the attempt shall be abandoned, and normal cell reselection shall be performed.

In case the MS is operating in NC2 mode, abnormal cell reselection shall override the NC2 mode and the MS shall perform the algorithm as described in this section.

10.1.3.2 Algorithm for cell re-selection from GSM to UTRAN based on cell ranking

The algorithm in this subclause shall be used for reselection from GSM to UTRAN if the conditions for the use of the cell reselection algorithm based on priority information (see subclause 10.1.3.3) are not satisfied.

If the GPRS 3G Cell Reselection list includes UTRAN frequencies, the MS shall, at least every 5 second update the value RLA_P for the serving cell and each of the at least 6 strongest non serving GSM cells.

The MS shall then reselect a suitable (see TS 25.304) UTRAN cell if:

- for a TDD cell the measured RSCP value is equal to or greater than TDD_GPRS_Qoffset for a period of 5 s and
- for an FDD cell the following criteria are all met for a period of 5 s:
 1. its measured RSCP value exceeds the value of RLA_P for the serving cell and all of the suitable (see 3GPP TS 43.022) non-serving GSM cells by the value FDD_GPRS_Qoffset,
 2. its measured Ec/No value is equal or greater than the value FDD_Qmin - FDD_Qmin_Offset, and
 3. its measured RSCP value is equal to or greater than FDD_RSCP_threshold.

In case of a cell reselection occurring within the previous 15 seconds, FDD_GPRS_Qoffset or TDD_GPRS_Qoffset is increased by 5 dB.

Where

- Ec/No and RSCP are the measured quantities, see subclause 8.1.5.
- FDD_RSCP_threshold equals FDD_RSCPmin – min(P_MAX – 21 dBm), 3 dB) if FDD_RSCPmin is broadcast on the serving cell, else Qrxlev_min + Pcompensation + 10 dB, if these parameters are available, otherwise the default value of FDD_RSCPmin.
- Qrxlev_min is the minimum required RX level in the UTRAN FDD cell (dBm), see 3GPP TS 25.304.
- Pcompensation is max(UE_TXPWR_MAX_RACH – P_MAX, 0) (dB), see 3GPP TS 25.304.
- UE_TXPWR_MAX_RACH is the maximum TX power level an MS may use when accessing the UTRAN FDD cell on RACH (dBm), see 3GPP TS 25.304.
- P_MAX is the maximum RF output power of the MS (dBm) in UTRAN FDD mode, see 3GPP TS 25.304.
- FDD_Qmin, FDD_GPRS_Qoffset and optionally FDD_RSCPmin and FDD_Qmin_Offset are broadcast on PBCCH of the serving cell.
- TDD_GPRS_Qoffset is broadcast on PBCCH of the serving cell.

Note 1: The parameters required to determine if the UTRAN cell is suitable are broadcast on BCCH of the UTRAN cell. An MS may start reselection towards the UTRAN cell before decoding the BCCH of the UTRAN cell, leading to a short interruption of service if the UTRAN cell is not suitable.

Note 2: If FDD_RSCPmin is broadcast, optimum GSM to UTRAN reselection performance is achieved if UTRAN cells at UTRAN coverage border areas are planned for +24 dBm UE power.

Note 3: The parameter TDD_Qoffset is an absolute threshold for reselection towards a target UTRAN TDD cell.

The MS shall store the UTRAN cell RSCP suitability criterion parameters above, whenever decoded from a UTRAN FDD cell of an equivalent PLMN while attempting to camp on the UTRAN FDD cell. The most recently decoded parameters from one UTRAN FDD cell of an equivalent PLMN are valid reselection criteria towards all UTRAN FDD cells. This list of parameters shall be cleared after PLMN selection (see 3GPP TS 23.122).

Cell reselection to UTRAN shall not occur within 5 seconds after the MS has reselected a GSM cell from an UTRAN cell if a suitable GSM cell can be found.

In case of a reselection attempt towards a barred UTRAN cell, the MS shall abandon further reselection attempts towards this UTRAN cell as defined by the T_{barred} value on the barred UTRAN cell (see 3GPP TS 25.331).

In case the highest ranked UTRAN cell is not suitable (see 3GPP TS 25.304) due to being part of the "list of forbidden LAs for roaming" or belonging to a PLMN which is not indicated as being equivalent to the registered PLMN, the MS may abandon further reselection attempts towards this UTRAN cell and all other cells on the same frequency, for a period of up to 20 min. If the MS has to perform cell selection, this limitation shall be removed. If the MS is redirected under GERAN control to a frequency for which the timer is running, any limitation on that frequency shall be removed.

If more than one UTRAN cell fulfils the above criteria, the MS shall select the cell with the greatest RSCP value.

10.1.3.3 Algorithm for inter-RAT cell re-selection based on priority information

This algorithm and its applicability are as specified in sub-clause 6.6.6.

10.1.3.4 Cell selection and re-selection to CSG cells and hybrid cells

If a mobile station is a member of at least one Closed Subscriber Group, i.e. at least one CSG ID and its PLMN ID is included in the MS's CSG Whitelist, then, in addition to normal cell reselection, the MS shall use an autonomous search function to detect UTRAN and/or E-UTRAN CSG cells and hybrid cells. The autonomous search function shall at least detect previously visited allowed CSG cells and previously visited hybrid cells whose CSG IDs are included in the CSG Whitelist of the MS.

NOTE: The MS does not perform autonomous cell reselection to CSG cells in packet transfer mode if NC2 mode is configured.

Measurement of CSG cells and cell re-selection to CSG cells in packet idle mode and in packet transfer mode shall follow the same rules as in subclause 6.6.7.1 (the performance requirements for the autonomous search and cell re-selection to a previously visited allowed CSG cell shall not apply in packet transfer mode). Cell re-selection to cells detected as hybrid cells in packet idle mode and in packet transfer mode shall follow the rules in subclause 6.6.7.1a (the performance requirements for the autonomous search and cell re-selection to a previously visited hybrid cell, whose CSG ID is included in the CSG Whitelist of the MS, shall not apply in packet transfer mode). Manual search and selection of CSG ID(s) in packet idle mode shall follow the same rules as in subclause 6.6.7.2.

The MS is not required to perform manual search and selection of CSG ID(s) while in packet transfer mode.

10.1.4 Network controlled Cell re-selection

The network may request measurement reports from the MS and control its cell re-selection. This is indicated by the parameter NETWORK_CONTROL_ORDER. The meaning of the different parameter values is specified as follows:

NC0	Normal MS control The MS shall perform autonomous cell re-selection.
NC1	MS control with measurement reports The MS shall send measurement reports to the network as defined in subclause 10.1.4.1. The MS shall perform autonomous cell re-selection.
NC2	Network control The MS shall send measurement reports to the network as defined in subclause 10.1.4.1. The MS shall only perform autonomous cell re-selection when the reselection is triggered by a downlink signalling failure as defined in subclause 6.5 or a random access failure as defined in 3GPP TS 44.018 and 3GPP TS 44.060 or if the cell is barred or the C1 criterion falls below zero. The MS shall only determine whether the cell is barred once camped on the cell.
RESET	The MS shall return to the broadcast parameters. Only sent on PCCCH or PACCH.

The parameter values NC1 and NC2 only apply in GMM Ready state (*A/Gb mode*) or RRC-Cell_Shared state (*Iu mode*). In GMM Standby state (*A/Gb mode*) or RRC-Idle mode or RRC-GRA_PCH state (*Iu mode*), the MS shall always use normal MS control independent of the ordered NC mode.

While in broadcast/multicast receive mode, the MS shall operate in Network Control mode NC0 even if it had been ordered otherwise by the network. If in GMM Ready state, the mobile station shall move to NC0 upon entering broadcast/multicast receive mode. When returning to packet idle mode, the mobile station shall revert to the control

mode ordered by the network before entering broadcast/multicast receive mode if the mobile station is still in GMM Ready state. If leaving broadcast/multicast receive mode to enter packet transfer mode, the MS shall apply the network control mode commanded by the network in the system information.

A set of measurement reporting parameters (NETWORK_CONTROL_ORDER, NC_REPORTING_PERIOD(s) and optionally REPORT_TYPE, MULTIBAND_REPORTING, SERVING_BAND_REPORTING, XXX_MULTIRAT_REPORTING, XXX_REPORTING_OFFSET, XXX_REPORTING_THRESHOLD, FDD_REPORTING_THRESHOLD_2, REP_PRIORITY, REPORTING_RATE, INVALID_BSIC_REPORTING, SCALE_ORD, FDD_REP_QUANT, Qsearch_P, E-UTRAN_REP_QUANT, E-UTRAN_FDD_REPORTING_THRESHOLD_2, E-UTRAN_TDD_REPORTING_THRESHOLD_2, E-UTRAN_FDD_MEASUREMENT_REPORT_OFFSET, E-UTRAN_TDD_MEASUREMENT_REPORT_OFFSET, Qsearch_P_E-UTRAN, UTRAN_CSG_XXX_REPORTING_THRESHOLD, UTRAN_CSG_FDD_REPORTING_THRESHOLD_2, E-UTRAN_CSG_XXX_REPORTING_THRESHOLD, E-UTRAN_CSG_XXX_REPORTING_THRESHOLD_2) is broadcast on BCCH and, excepting E-UTRAN parameters, on PBCCH if it exists. XXX indicates, as applicable, GSM frequency band (e.g. 900, 850, etc) or other radio access technology/mode (e.g. FDD, TDD, E-UTRAN, E-UTRAN FDD, E-UTRAN TDD). This set of parameters may also be sent individually to an MS on PACCH or, excepting E-UTRAN parameters, on PCCCH in :

- a PACKET MEASUREMENT ORDER message, in which case it overrides the NC parameters broadcast in the serving cell. These individual parameters are only valid in the serving cell.
- a PACKET CELL CHANGE ORDER message, in which case it overrides the NC parameters broadcast in the target cell. These individual parameters are only valid in the target cell.

The individual parameters are valid until the RESET command is sent to the MS or there is a downlink signalling failure or a random access failure or if the cell is barred or the C1 criterion falls below zero or the MS goes to the GMM Standby state (*A/Gb mode*) or RRC-Idle mode or RRC-GR_A_PCH state (*Iu mode*) or MS enters dedicated mode or dual transfer mode (*A/Gb mode*) or RRC-Cell_Dedicated state (*Iu mode*). Before the MS has acquired NC parameters when entering a new cell, the MS shall assume mode NC0 unless NC0, NC1 or NC2 mode was explicitly commanded by a PACKET CELL CHANGE ORDER message in the previous cell.

A parameter NC_FREQUENCY_LIST may also be sent individually to an MS on PCCCH or PACCH. This list adds/deletes frequencies to the BA(GPRS) both for cell re-selection and for measurement reports. The NC_FREQUENCY_LIST and the REP_PRIORITY are valid until an empty NC_FREQUENCY_LIST is sent to the MS, there is a downlink signalling failure or the MS selects a new cell or the BA(GPRS) that is modified by the NC_FREQUENCY_LIST changes or MS enters dedicated mode (*A/Gb mode*) or RRC-Cell_Dedicated state (*Iu mode*).

The same considerations regarding validity apply to lists that include cells with other radio access technologies.

A list given by Packet Cell Change Order applies in the new cell. This list may also include cells with other radio access technologies.

If the MS operates in NC1 or NC2 modes, the network may control UTRAN measurements per individual UTRAN frequency by the parameters Measurement_Control_UTRAN and E-UTRAN measurements per individual E-UTRAN frequency by the parameters Measurement_Control_E-UTRAN. In NC1 mode, cell reselection requirements shall have priority over reporting requirements. An MS operating in NC1 mode is not required to report a cell if the MS is not monitoring that cell for the purpose of cell reselection.

All signalling for support of network controlled cell re-selection and measurement reports are defined in 3GPP TS 44.060.

10.1.4.1 Measurement reporting

When ordered to send measurement reports, the MS shall continuously monitor all carriers in BA(GPRS) or as indicated by the parameter NC_FREQUENCY_LIST and the BCCH carrier of the serving cell. The measurement requirements are defined in subclause 10.1.1 for the actual packet mode.

For each carrier, the measured received signal level (RXLEV) shall be the average of the received signal level measurement samples in dBm taken on that carrier within the reporting period. The reporting period is defined as follows:

- in packet idle mode or MAC-Idle state, the reporting period is NC_REPORTING_PERIOD_I rounded off to the nearest smaller integer multiple of DRX period if NC_REPORTING_PERIOD_I is greater than DRX period, else, the reporting period is DRX period;
- in packet transfer mode or MAC-Shared state, the reporting period is indicated in NC_REPORTING_PERIOD_T.

In averaging, measurements made during previous reporting periods shall always be discarded. The start of the first reporting period may be random.

After each reporting period, the MS shall send a measurement report to BSS (see 3GPP TS 44.060). The MS shall then discard any previous measurement report, which it has not been able to send. Provided that the MS has received BSIC for all GSM neighbour cells, the parameter REPORT_TYPE indicates if the MS shall use Packet Measurement Report (normal reporting) or Packet Enhanced Measurement Report (enhanced reporting) (see 3GPP TS 44.060). The measurement report shall contain:

- RXLEV for the serving cell;
- received signal level for the non-serving cells:
 - If the requirements for reporting a CSG cell are met, the MS shall follow the requirements specified in sub-clause 8.4.9 for the reporting of a CSG cell. Requirements in sub-clause 8.4.9 take precedence over the requirements in the following bullets.
 - For normal measurement reporting, carriers shall be reported if they are among the 6 strongest carriers and BSIC is successfully decoded and allowed (see subclause 10.1.1), i.e. either equal to the BSIC of the list or with allowed NCC part of BSIC. In the latter case, which applies for BA(BCCH) where no BSIC is given, the decoded BSIC shall be included in the report. For an MS supporting network sharing, the cells with BSIC equal to the BSIC of the list shall also have a permitted NCC part (see clause 7.2). If the mobile station has acquired the GSM Neighbour Cell list (see 3GPP TS 44.060), only cells present in that list shall be included in the report. In the case of a multiband MS, the MS shall report the number of strongest BCCH carriers in each band as indicated by the parameter MULTIBAND_REPORTING (see subclause 8.4.3), broadcast on PBCCH, or if PBCCH does not exist, on BCCH. For multi-RAT MS, the MS shall report the number of best valid cells in each other radio access technology/mode as indicated by the parameters XXX_MULTIRAT_REPORTING, see subclause 8.4.7. In this case, the received signal level is replaced by the relevant measurement quantity (see subclause 8.1.5). Valid cells are defined in subclause 8.4.7;
 - For Enhanced Measurement Reporting, cells shall be reported if they are among the at least 6 strongest carriers, and BSIC is successfully decoded and valid (see subclause 10.1.1) or, if indicated by the parameter INVALID_BSIC_REPORTING, with known and allowed NCC part. For an MS supporting network sharing, a valid BSIC is a BSIC of the list with a permitted NCC part. The neighbour cells shall be reported according to the priority defined in subclause 8.4.8.1. For other radio access technology/mode, RXLEV is replaced by the relevant measurement quantity (see subclause 8.1.5);
- BSIC_SEEN (only for Enhanced Measurement Reporting).
Indicates if a GSM cell with invalid BSIC and allowed NCC part of the BSIC is one of the six strongest cells.

In the case of Packet Transfer mode or MAC-Shared state with the NC_REPORTING_PERIOD_T = 0.48 s the MS shall report a new strongest GSM cell in the measurement report at the latest 5 s after a new strongest cell (which is part of the BA(GPRS)) has been activated under the following network conditions: Initial serving cell at RXLEV= -70 dBm, with 6 neighbours at RXLEV= -75 dBm. Then the new BCCH carrier is switched on at RXLEV= -60 dBm.

NOTE: Because of test equipment limitations it is acceptable to activate the new carrier to replace one of the 6 neighbours.

A UTRAN capable MS shall report a new best UTRAN cell, which is part of the neighbour cell list, at the latest 5 seconds after it has been activated under the condition that there is only one UTRAN frequency in the neighbour cell list (and no E-UTRAN frequencies in the neighbour cell list) and that no new GSM cells are activated at the same time and under good radio conditions. A E-UTRAN capable MS that supports measurement reporting of E-UTRAN cells shall report a new best E-UTRAN cell, on a frequency contained in the E-UTRAN Neighbour Cell list, at the latest 5 seconds after it has been activated under the condition that there is only one E-UTRAN frequency in the E-UTRAN Neighbour Cell list (and no UTRAN frequencies in the 3G Neighbour Cell list) and that no new GSM cells

are activated at the same time and under good radio conditions. For test purposes the following radio conditions can be used:

Serving GSM cell at RXLEV= -70 dBm, with 6 GSM neighbours at RXLEV= -75 dBm. Then either an UTRAN FDD neighbour cell or an UTRAN TDD neighbour cell or an E-UTRAN FDD neighbour cell or an E-UTRAN TDD neighbour cell is switched on. The radio conditions for the UTRAN FDD cells are as follows (see 3GPP TS 25.101 for definitions):

Parameter	Unit	UTRAN FDD Cell
<i>CPICH_Ec/Ior</i>	dB	-10
<i>P-CCPCH_Ec/Ior</i>	dB	-12
<i>SCH_Ec/Ior</i>	dB	-12
<i>PICH_Ec/Ior</i>	dB	-15
<i>DPCH_Ec/Ior</i>	dB	$-\infty$
<i>OCNS_Ec/Ior</i>	dB	-0.94
\hat{I}_{or}/I_{oc}	dB	10
<i>I_{oc}</i>	dBm/3.84 MHz	-70
<i>CPICH_Ec/Io</i>	dB	-10.4
<i>CPICH RSCP</i>	dBm	-70
FDD_MULTIRAT_REPORTING	integer	1
Qsearch_P	integer	7 (search always)
Propagation Condition	AWGN	

The radio conditions for the UTRAN TDD cell (either 3.84 Mcps TDD option or 1.28 Mcps TDD option) are as follows (see 3GPP TS 25.123 for definitions and for the values of the remaining configuration parameters):

Parameter	Unit	UTRAN TDD Cell (3.84 Mcps option)	
		0	8
<i>Timeslot Number</i>		0	8
<i>P-CCPCH_Ec/Ior</i>	dB	-3	
<i>SCH_Ec/Ior</i>	dB	-9	-9
<i>SCH_{t_offset}</i>	integer	0	0
<i>PICH_Ec/Ior</i>	dB		-3
<i>OCNS_Ec/Ior</i>	dB	-3.12	-3.12
<i>P-CCPCH RSCP</i>	dBm	-70	-70
TDD_MULTIRAT_REPORTING	integer	1	
Qsearch_P	integer	7 (search always)	
Propagation Condition	AWGN		

NOTE: On timeslot 8 the P-CCPCH is not transmitted; on that timeslot, the P-CCPCH RSCP defines the power level of the beacon channel.

Parameter	Unit	UTRAN TDD Cell (1.28 Mcps option)	
<i>Timeslot Number</i>		0	DwPTS
<i>P-CCPCH_{Ec/Ior}</i>	dB	-3	
<i>DwPCH_{Ec/Ior}</i>	dB		0
<i>OCNS_{Ec/Ior}</i>	dB	-3	
<i>P-CCPCH RSCP</i>	dBm	-70	
TDD_MULTIRAT_ REPORTING	integer	1	
Qsearch_P	integer	7 (search always)	
Propagation Condition	AWGN		

The radio conditions for the E-UTRAN FDD cell are as follows (see 3GPP TS 36.101 for definitions):

Parameter	Unit	E-UTRAN FDD Cell
<i>Channel Bandwidth</i>	MHz	10
<i>PSS_{RB}, SSS_{RB}, PBCH_{RA}, PBCH_{RB}, PCFICH_{RA}, PHICH_{RA}, PHICH_{RB}, PDCCH_{RA}, PDCCH_{RB}, PDSCH_{RA}, PDSCH_{RB}</i>	dB	0
<i>OCNG_{RA}</i> (Note 1)	dB	0
<i>OCNG_{RB}</i> (Note 1)	dB	0
N_{oc}	dBm/15kHz	-98
\hat{E}_s/I_{ot}	dB	12
<i>RSRP</i>	dBm/15kHz	-86
<i>SCH_{RP}</i>	dBm	-86
Qsearch_P	integer	7 (search always)
Qsearch_P_E-UTRAN	integer	7 (search always)
E-UTRAN_MULTIRAT_ REPORTING	integer	1
OCNG pattern	OP.2 FDD (see 3GPP TS 36.133)	
MIMO configuration	single transmitter	
Propagation Condition	AWGN	
NOTE 1: OCNG shall be used such that the E-UTRAN cell is fully allocated and a constant total transmitted power spectral density is achieved for all OFDM symbols.		

The radio conditions for the E-UTRAN TDD cell are as follows (see 3GPP TS 36.101 for definitions):

Parameter	Unit	E-UTRAN TDD Cell
<i>Channel Bandwidth</i>	MHz	10
<i>PSS_RB, SSS_RB, PBCH_RA, PBCH_RB, PCFICH_RA, PHICH_RA, PHICH_RB, PDCCH_RA, PDCCH_RB, PDSCH_RA, PDSCH_RB</i>	dB	0
<i>OCNG_RA</i> (Note 1)	dB	0
<i>OCNG_RB</i> (Note 1)	dB	0
N_{oc}	dBm/15kHz	-98
\hat{E}_s/I_{ot}	dB	12
<i>RSRP</i>	dBm/15kHz	-86
<i>SCH_RP</i>	dBm	-86
Qsearch_P	integer	7 (search always)
Qsearch_P_E-UTRAN	integer	7 (search always)
E-UTRAN_MULTIRAT_REPORTING	integer	1
OCNG pattern	OP.2 TDD (see 3GPP TS 36.133)	
MIMO configuration	single transmitter	
Propagation Condition	AWGN	
NOTE 1: OCNG shall be used such that the E-UTRAN cell is fully allocated and a constant total transmitted power spectral density is achieved for all OFDM symbols.		

The allowed reporting time is increased by 5 seconds for each additional UTRAN frequency in the neighbour cell list or for each additional E-UTRAN frequency in the neighbour cell list and by the time required for BSIC decoding of new activated GSM cells. However, multiple UTRAN cells on the same frequency in the neighbour cell list does not increase the allowed reporting time.

NOTE: The requirements above assume that only one UTRAN or E-UTRAN frequency is switched on.

In case a cell is abandoned for cell reselection attempts due to being part of the “list of forbidden LAs for roaming” (for UTRAN cells) or part of the “list of forbidden TAs for roaming” (for E-UTRAN cells), or belonging to a PLMN which is not indicated as being equivalent to the registered PLMN, as defined in subclause 10.1.3.2 and in subclause 10.1.3.3, the MS may abandon monitoring and reporting this UTRAN or E-UTRAN cell and all other cells on the same frequency for the same period of time that reselection attempts are abandoned. If the MS has received the PCID to TA Mapping information element for the E-UTRAN frequency of the cell (see 3GPP TS 44.060), the MS may abandon, for the same period of time that reselection attempts are abandoned, monitoring and reporting this E-UTRAN cell and any E-UTRAN cell which known to belong to the same Tracking Area.

NOTE: Monitoring and reporting of E-UTRAN cells whose PCID does not belong to the PCID group associated with the forbidden Tracking Area is not affected.

In packet transfer mode or MAC-Shared state, for some allowed multislot configurations (see 3GPP TS 45.002), identification of a UTRAN TDD cell may not be guaranteed. In such cases, the MS may not be able to fulfil the requirement above. If after 5 seconds the MS has not been able to identify a UTRAN TDD cell, the MS is allowed to stop searching for it in the current GSM cell.

In packet transfer mode, a multi-RAT MS with no or an empty CSG Whitelist is not required to measure, and shall not report, cells known to be CSG cells; a multi-RAT MS indicating support of neither "UTRA CSG Cells Reporting" nor "E-UTRA CSG Cells Reporting" in the *MS Radio Access Capability* IE (see 3GPP TS 24.008) shall not report cells known to be CSG cells other than as part of a cell change notification procedure (see 3GPP TS 44.060) when the target cell is a CSG cell.

10.1.4.2 Cell re-selection command

A cell re-selection command may be sent from the network to an MS. When the MS receives the command, it shall re-select the cell according to the included cell description and change the network control mode according to the command (see 3GPP TS 44.060). The command may include re-selection of another radio access technology/mode.

If an MS receives a cell re-selection command towards a GSM cell to which it is not synchronised, the MS shall indicate a packet cell change failure (see 3GPP TS 44.060).

If a UTRAN capable MS receives a cell re-selection command towards a not known UTRAN cell (see 3GPP TS 25.133 and 3GPP TS 25.123), or if a E-UTRAN capable MS receives a cell re-selection command towards a not known E-UTRAN cell (see 3GPP TS 36.133), then the MS shall search for synchronisation information up to 800 ms. In case of failure, the MS shall return to the old cell and indicate a packet cell change failure (see 3GPP TS 44.060).

10.1.4.3 Exceptional cases

An MS in network control mode NC1 or NC2 may enter an exceptional case if a circuit switched connection is established, which takes precedence over GPRS cell re-selection. This includes an MS operating in DTM.

In such a case the MS is not required to send measurement reports according to subclause 10.1.4.1, and shall not obey any cell re-selection command.

Whenever the exceptional case ends, the MS shall resume the GPRS mode tasks as specified in sub-clause 10.

10.1a Measurement and Reporting of CSG Cells and hybrid cells

If a mobile station supports "UTRA (respectively E-UTRA) CSG Cells Reporting", it shall support MIB/SIB reading and reporting in packet transfer mode. The MS may acquire routing parameters and the CSG ID for a UTRAN (respectively E-UTRAN) CSG cell by reading MIB and SIB3 (respectively MIB and SIB1) of that cell. The MS is allowed to autonomously skip idle frames or TDMA frames on PDCH to read MIB and SIB and only skips the timeslot(s) or TDMA frame(s) during which either MIB or SIB is transmitted.

A multi RAT mobile station which indicates support of "UTRA CSG Cells Reporting" (respectively "E-UTRA CSG Cells Reporting") in the *MS Radio Access Capability* IE (see 3GPP TS 24.008) shall report CSG cells and hybrid cells in packet transfer mode according to the procedures in sub-clause 8.4.9 if:

- the cell is the strongest of any cell on the same frequency (see 3GPP TS 25.304 and 3GPP TS 36.304 for the definition of the strongest cell); and
- (for UTRAN FDD CSG cells) the reported value (CPICH Ec/No) is equal to or higher than `UTRAN_CSG_FDD_REPORTING_THRESHOLD` and the non-reported value (CPICH RSCP) is equal to or higher than `UTRAN_CSG_FDD_REPORTING_THRESHOLD_2`; and
- (for UTRAN TDD CSG cells) the reported value (P-CCPCH RSCP) is equal to or higher than `UTRAN_CSG_TDD_REPORTING_THRESHOLD`; and
- (for E-UTRAN FDD CSG cells) the reported value (RSRQ) is equal to or higher than `E-UTRAN_CSG_FDD_REPORTING_THRESHOLD` and the non-reported value (RSRP) is equal to or higher than `E-UTRAN_CSG_FDD_REPORTING_THRESHOLD_2`; and
- (for E-UTRAN TDD CSG cells) the reported value (RSRQ) is equal to or higher than `E-UTRAN_CSG_TDD_REPORTING_THRESHOLD` and the non-reported value (RSRP) is equal to or higher than `E-UTRAN_CSG_TDD_REPORTING_THRESHOLD_2`; and
- the conditions specified in 3GPP TS 44.060 are met.

The parameters `Qsearch_P` and `Measurement_Control_UTRAN` are not applicable to UTRAN CSG cells. The parameters `Qsearch_P_E-UTRAN` and `Measurement_Control_E-UTRAN` are not applicable to E-UTRAN CSG cells.

If information about dedicated CSG frequencies is available to the MS, the MS may restrict the measurement of CSG cells only on these dedicated frequencies and on the other frequencies listed in the system information.

10.2 RF Power Control

Sub-clauses 10.2.1 and 10.2.2 do not apply for the PDCH/H in Exclusive MAC mode while in DTM. In this case:

- The MS shall apply the output power ordered by the network on the SACCH to all channels (both for the TCH/H and the PDCH/H).
- The network shall use the same output power on the dedicated connection and on all the blocks on the PDCH/H addressed to the MS. Blocks not addressed to the MS may be transmitted at a lower power level. As an exception, the bursts transmitted on the BCCH carrier shall be transmitted at the BCCH level.

NOTE: Power control is not applicable to point-to-multipoint services if transmission is without ARQ (see 3GPP TS 44.060).

10.2.1 MS output power

The RF output power, P_{CH} , to be employed by the MS on each individual uplink PDCH shall be:

$$P_{CH} = \min(\Gamma_0 - \Gamma_{CH} - \alpha * (C + 48), P_{MAX}), \quad (1)$$

where

Γ_{CH} is an MS and channel specific power control parameter, sent to the MS in an RLC control message (see 3GPP TS 44.060). For those uplink PDCHs, for which Γ_{CH} has not been defined, value 0 shall be used.

Γ_0 = 39 dBm for GSM 400, GSM 700, GSM 850 and GSM 900
= 36 dBm for DCS 1 800 and PCS 1900

α is a system parameter, broadcast on PBCCH or optionally sent to MS in an RLC control message (see 3GPP TS 44.018 and 3GPP TS 44.060).

C is the normalised received signal level at the MS as defined in 10.2.3.1.

P_{MAX} is the maximum allowed output power in the cell.

For DCS 1800 and PCS 1900, $P_{MAX} =$
GPRS_MS_TXPWR_MAX_CCH if present,
MS_TXPWR_MAX_CCH otherwise:

For all other bands, $P_{MAX} =$
LB_MS_TXPWR_MAX_CCH + Band_offset, if
LB_MS_TXPWR_MAX_CCH is present, otherwise
GPRS_MS_TXPWR_MAX_CCH if present, otherwise
MS_TXPWR_MAX_CCH;

where Band_offset equals:
0 dB for GSM 850 and GSM 900,
-2 dB for GSM 700,
-6 dB for GSM 400.

All power values are expressed in dBm.

When the MS receives new Γ_{CH} or α values, the MS shall use the new value to update P_{CH} according to equation (1) 2 radio blocks after the end of the frame containing the last timeslot of the message block containing the new value, which ensures 2 blocks time for processing even in case of timeslot reconfiguration.

The MS may round the calculated output power to the nearest nominal output power value (see 3GPP TS 45.005) although a higher resolution is preferred. The output power actually transmitted by the MS shall fulfil the absolute accuracy as specified in 45.005. In addition, the transmitted power shall be a monotonic function of the calculated output power and any change of 2 dB in the calculated value shall correspond to a change of 2 ± 1.5 dB in the transmitted value.

The MS shall use the same output power on all four bursts within one radio block.

When accessing a cell on the P-RACH or RACH (random access) or on the P-ACCH when sending the PS Handover Access message, the MS shall use the output power defined by $\min\{P_{MAX}, P_{RED}\}$, where P_{RED} is the power defined in subclause 4.2. If $INIT_PWR_RED$ is not broadcast, the MS shall use the output power defined by P_{MAX} for all random access attempts.

$MS_TXPWR_MAX_CCH$ is broadcast on the BCCH of the cell. A class 3 DCS1 800 MS shall add to it the value $POWER_OFFSET$ broadcast on the BCCH.

$GPRS_MS_TXPWR_MAX_CCH$ is broadcast on PBCCH or CPBCCH of the serving cell and in case of DTM, sent on SACCH and optionally on main DCCH.

$LB_MS_TXPWR_MAX_CCH$ is optionally broadcast on BCCH of the serving cell, and on PBCCH, PCCCH and PACCH if PBCCH is present.

$INIT_PWR_RED$ is broadcast on the BCCH of the cell. After a cell re-selection, within GERAN, if access is needed before $INIT_PWR_RED$ has been acquired from the serving cell, the value in the previous cell shall be applied.

If the MS accesses a cell on the P-RACH before receiving $GPRS_MS_TXPWR_MAX_CCH$ on PBCCH and if $LB_MS_TXPWR_MAX_CCH$ is not broadcast, the MS shall determine P_{MAX} using $MS_TXPWR_MAX_CCH$ as default.

If a calculated output power is not supported by the MS, the MS shall use the supported output power which is closest to the calculated output power.

In case of DTM, if a valid C value does not exist, the MS may transmit on each uplink PDCH with the output power signalled in the L1 header of the main SACCH, until a valid C value exists.

The value of Γ_{CH} shall be the same for both PDCHs constituting an uplink PDCH-pair in RTTI configuration (see 3GPP TS 44.060).

The MS may calculate the C value in dedicated mode.

10.2.2 BTS output power

Downlink power control can only be used when the serving BCCH or CPBCCH and the used PDCH frequencies are in the same frequency band.

On the PDCHs that contain PBCCH or PCCCH, the BTS shall use constant output power, which may be lower than the output power used on BCCH. The power reduction (P_b) used on PCCCH, relative to the output power used on BCCH, is broadcast on PBCCH. For COMPACT, on the blocks that contain CPBCCH, CPCCCH, CFCCH, or CSCH, the BTS shall use constant output power.

On PTCCH/D, the BTS shall use the same output power as for PBCCH, or BCCH if PBCCH does not exist. As an exception to this, the output power for some of the PTCCH/D blocks may be lower in some cases (e.g. with adaptive antennas), but with no requirements for the MS to decode them. The network is however responsible to provide each MS with required TA information.

On other PDCH radio blocks, downlink power control may be used. The BTS shall use the same output power on all four bursts within one radio block except for bursts transmitted on the BCCH carrier. Thus, a procedure may be implemented in the network to control the output power of the downlink transmission based on the Channel Quality Reports.

On PDCHs that do not contain PBCCH or PCCCH and do not use downlink power control (as indicated in the assignment message), the BTS shall use a constant output power with the exception that it is not required to transmit on every block. If the output power used on the transmitted blocks is not equal to (BCCH level – P_b) then the MS is not required to fulfil 3GPP TS 45.005 requirements for the first 25 blocks addressed to this MS.

In case of downlink power control, parameter P_0 is used: P_0 is defined as a power reduction relative to BCCH or CPBCCH and is included in the assignment message. The value of P_0 is not allowed to change during Packet Transfer Mode or MAC-Shared state except in the case a reassignment or a new assignment is established not including any of the previously assigned PDCH(s). A MS shall only have one P_0 value at a time.

On each PDTCH/D block, the PR field of the MAC header, if present and if downlink power control is used, shall indicate the output power level used to send this block (see 3GPP TS 44.060). There shall be two PR management

cases, PR mode A and PR mode B, as indicated by the PR_MODE parameter in the assignment (see 3GPP TS 44.060):

- in PR mode A, the PR value shall be calculated relative to the P0 value of the MS to which the RLC block is addressed;
- in PR mode B, the network shall use the same P0 value for all the MS with a TBF established on the same PDCH. Consequently, the PR value shall be calculated relative to this P0 value.

The network shall not be allowed to change between PR modes during a TBF. The network shall only allocate to an MS one PR_MODE at a time.

NOTE: Correct MS behaviour can not be assumed if PR mode B is used with adaptive antennas.

The MS is required to meet the 45.005 specification under the following conditions:

For synchronisation purpose, the network shall ensure that each MS with an active TBF in uplink or downlink receives at least one block transmitted with a coding scheme and a modulation that can be decoded by that MS every 360 millisecond interval (78 TDMA frames). If downlink power control is used:

- in PR mode A, this block shall be addressed (RLC information) to this MS and shall contain a usable PR field (i.e. not set to Not usable as specified in 3GPP TS 44.060);
- in PR mode B, this block shall contain a usable PR field (i.e. not set to Not usable as specified in 3GPP TS 44.060) and does not necessarily have to be addressed to any particular MS. The PR field remains optional in a downlink RLC/MAC control block (see 3GPP TS 44.060).

If downlink power control is used, the BTS shall limit its output power on blocks addressed to a particular MS (USF or RLC blocks) to levels between (BCCH level – P0dB) and (BCCH level – P0dB – 10dB). For other blocks the output power shall not exceed (BCCH level – P0dB). For COMPACT, the BCCH level shall be replaced by the CPBCCH level in these formulas. The output power must be sufficient for the MS for which the RLC block is intended as well as the MS(s) for which the USF is intended (see 3GPP TS 44.060).

As an exception to the rules above, the bursts transmitted on the BCCH carrier shall be transmitted at the BCCH level.

In DTM multislot configurations, if the BTS output power for the CS timeslot is not within the range from the maximum downlink power allowed for the MS on the PS timeslot(s) to a power level 10 dB lower, the MS is not required to fulfil the requirements in 3GPP TS 45.005 on the CS timeslot and/or the PS timeslot(s).

10.2.3 Measurements at MS side

A procedure shall be implemented in the MS to monitor periodically the downlink Rx signal level and quality from its serving cell.

10.2.3.1 Deriving the C value

10.2.3.1.1 Packet idle mode or MAC-Idle state

In packet idle mode or MAC-Idle state, the MS shall periodically measure the received signal level of the PCCCH or, if PCCCH is not existing, the CCCH or, for COMPACT, the CPCCCH or CPBCCCH, CFCCH, and CSCH. The MS shall measure the received signal level of each paging block monitored by the MS according to its current DRX mode and its paging group.

The normalised C value for each radio block is calculated:

$$C_{\text{block},n} = SS_{\text{block},n} + P_b \quad (2)$$

where

$SS_{\text{block},n}$ is the mean of the received signal level of the four normal bursts that compose the block.

P_b is the BTS output power reduction (relative to the output power used on BCCH) used on the channel on which the measurements are performed. For PCCCH, P_b is broadcast on PBCCH. If frequency hopping is being used on the associated physical channel, P_b shall be reduced by 25% for each burst in the block which is received on the BCCH frequency. For BCCH and for COMPACT, $P_b = 0$ (not broadcast).

Finally, the $C_{\text{block},n}$ values are filtered with a running average filter:

$$C_n = (1-a) * C_{n-1} + a * C_{\text{block},n},$$

where a is the forgetting factor:

$$a = 1/\text{MIN}(n, \text{MAX}(5, T_{\text{AVG}_W} * N_{\text{DRX}})).$$

N_{DRX} = the average number of monitored blocks per multiframe (see 3GPP TS 45.002).

T_{AVG_W} is broadcast on PBCCH or, if PBCCH does not exist, on BCCH, or on CPBCCCH or optionally sent to mobile station in an RLC/MAC control message (see 3GPP TS 44.060).

n is the iteration index. The filter shall be restarted with $n=1$ for the first sample every time a new cell is selected. If the MS leaves dedicated mode and then enters packet idle mode or MAC-Idle state, the filter shall be restarted with $n=1$ for the first sample in case there is no valid C value during dedicated mode. Otherwise, when entering packet idle mode or MAC-Idle state, the filter shall continue from the n and C_n values obtained during previous mode. The filter shall also continue from its previous state if N_{DRX} is changed.

The current C_n value shall be used in formula (1) in subclause 10.2.1 to calculate the output power when the MS transfers its first radio block.

10.2.3.1.2 Packet transfer mode or MAC-Shared state

In packet transfer mode or MAC-Shared state, the MS shall use the same received signal level measurements as made for cell reselection on the BCCH carrier of the serving cell (see 10.1.1.2) or, for COMPACT, on the CPBCCCH carrier of the serving cell (see 12.4.1.2). The measurements shall be filtered with a running average filter:

$$C_n = (1-b) * C_{n-1} + b * SS_n,$$

where

SS_n is the received signal level of the measurement samples.

b is the forgetting factor:

$$b = 1 \text{ for } n=1;$$

$$b = 1/(6 * T_{\text{AVG}_T}).$$

n is the iteration index. The filter shall be restarted with $n=1$ for the first sample at every cell change. When entering packet transfer mode from packet idle mode or MAC-Shared state from MAC-Idle state, the filter shall continue from the n and C_n values obtained during packet idle mode or MAC-Idle state. In case the MS and the network support enhanced DTM CS release procedure, when entering packet transfer mode from DTM, the filter shall continue from the n and C_n values obtained during DTM. When entering DTM from dedicated mode, the filter shall be restarted with $n=1$ for the first sample in case there is no valid C value during dedicated mode. In case the MS and the network support enhanced DTM CS establishment procedure, when entering DTM from packet transfer mode, the filter shall continue from the n and C_n values obtained during packet transfer mode.

If indicated by the parameter PC_MEAS_CHAN, the MS shall instead measure the received signal level of each radio block on one of the PDCHs in BTTI configuration or on one of the PDCH-pairs in RTTI configuration monitored by the MS for PACCH. If downlink power control is used, PC_MEAS_CHAN shall indicate measurements on the BCCH or CPBCCCH, or the MS is not required to fulfil 45.005 requirements. The MS may discard new PC_MEAS_CHAN values received during packet transfer mode or MAC-Shared state. For each downlink radio block $C_{\text{block},n}$ shall be derived according to formula (2) specified in 10.2.3.1.1 (if PBCCH does not exist, and for COMPACT, $P_b = 0$). Finally, the $C_{\text{block},n}$ values are filtered with a running average filter:

$$C_n = (1-c) * C_{n-1} + c * C_{\text{block},n},$$

where c is the forgetting factor:

$$c = 1 \text{ for } n=1;$$

$$c = 1/(12 * T_{\text{AVG}_T}).$$

n is the iteration index. The filter shall be restarted with $n=1$ for the first sample at every cell change. When entering packet transfer mode from packet idle mode or MAC-Shared state from MAC-Idle state, the filter shall continue from the n and C_n values obtained during packet idle mode or MAC-Idle state. In case the MS and the network support enhanced DTM CS release procedure, when entering packet transfer mode from DTM, the filter shall continue from the n and C_n values obtained during DTM. When entering DTM from dedicated mode, the filter shall be restarted with $n=1$ for the first sample in case there is no valid C value during dedicated mode. In case the MS and the network support enhanced DTM CS establishment procedure, when entering DTM from packet transfer mode, the filter shall continue from the n and C_n values obtained during packet transfer mode.

NOTE 1: This method is suitable in the case where BCCH or CPBCCCH is in another frequency band than the used PDCHs.

The current C_n value shall be used to update formula (1) in subclause 10.2.1 each time a new C_n value is obtained or whenever the MS applies new Γ_{CH} or α values.

For each correctly received block on one of the PDCHs monitored by the MS, the MS shall calculate the variance of the received signal level as:

$$BL_VAR_n = 1/(j-1) * \text{SUM}(SS_k - SS_{\text{block},n})^2, k = 1, \dots, 4$$

where SS_k is the received signal level of burst k within the block.

$SS_{\text{block},n}$ is the mean of the received signal level of the j normal bursts that compose the radio block.

j is the number of bursts in the radio block = 4.

If frequency hopping is used and 1 burst of the block is received on the BCCH carrier, that burst shall be discarded from the calculation ($j = 3$). If 2 bursts are received on the BCCH carrier, the whole block shall be discarded. If 3 bursts are received on the BCCH carrier, the other burst shall be discarded ($j = 3$).

If more than one PDCH are monitored the MS shall for each block period try to find one correctly received block for the BL_VAR calculation. The block may be taken from any of the monitored PDCHs.

The reported value, SIGN_VAR, shall be the average of BL_VAR within the reporting period. The first reporting period starts with and includes the first assignment message for an uplink or downlink transfer. The reporting period ends, and the subsequent reporting period starts, no earlier than two blocks before the transmission of a quality

report and no later than one block before the transmission of a quality report. In averaging, measurements made during previous reporting periods shall always be discarded.

SIGN_VAR shall be included in the channel quality report (see subclause 10.2.3.2.3). If the channel quality report is included in a PACKET RESOURCE REQUEST message, which is retransmitted due to lack of response (see 3GPP TS 44.060, 3GPP TS 44.160), the same or the most recent SIGN_VAR value shall be sent and no new reporting period shall be started. This will ensure that a valid SIGN_VAR value exists. The most recent SIGN_VAR value corresponds to the most recent average of BL_VAR computed since the beginning of the last reporting period.

T_{AVG,T} and PC_MEAS_CHAN are broadcast on PBCCH or, if PBCCH does not exist, on BCCH or on CPBCCH or optionally sent to mobile station in an RLC/MAC control message (see 3GPP TS 44.060).

10.2.3.2 Derivation of Channel Quality Report

The channel quality is measured as the interference signal level during idle frames of the multiframe, when the serving cell is not transmitting. No measurements shall be taken on the BCCH carrier of the serving cell since the BTS transmits with constant output power on this carrier. For COMPACT, the channel quality is measured as the interference signal level during a PDTCH or PACCH block (see Annex C). No measurements shall be taken on the CPBCCH, CPCCCH, PTCCH, CFCCH, or CSCH since the BTS of the neighbouring co-channel cells either does not transmit or transmits with constant output power.

10.2.3.2.1 Packet transfer mode or MAC-Shared state

In case of a downlink dual carrier assignment, the measurements specified in this subclause shall be made separately on both radio frequency channels.

In packet transfer mode or MAC-Shared state, the MS shall measure the interference signal level on the same radio frequency channel as the assigned PDCHs. The MS shall make these measurements during the search frames and PTCCH frames, which are not required for BSIC decoding or the timing advance procedure. For COMPACT, the MS shall estimate the interference level during PDTCH/PACCH bursts (see Annex C).

Additionally, a multi-RAT MS is allowed to ignore interference signal level measurements in search frames according subclause 10.1.1.3.

The MS shall perform interference signal measurements on as many of the channels (timeslots) as possible and as a minimum:

For multislot class type 1 MS (see 3GPP TS 45.002), on the PDCH timeslot numbers TS_{min} to TS_{max}, where

TS_{min} = the lowest numbered timeslot assigned (on the respective radio frequency channel in case of a downlink dual carrier assignment) for uplink or downlink transfer including downlink PACCH associated with an uplink transfer.

TS_{max} = MIN(TS_{min} + Rx - 1, 7).

Rx = the maximum number of receive timeslots that the MS can use per TDMA frame according to its multislot class, or Equivalent multislot class in case of a downlink dual carrier assignment (see 3GPP TS 45.002).

In case of DTM, the type 1 MS shall perform interference measurements also on the TCH timeslot. Interference measurements need not be supported on PDCH timeslot numbers above the TCH timeslot plus one.

For multislot class type 2 MS (see 3GPP TS 45.002), on the maximum number of receive timeslots (Rx) that the MS can use per TDMA frame according to its multislot class, or Equivalent multislot class in case of a downlink dual carrier assignment (see 3GPP TS 45.002), in the following priority order, except that no measurements are required on any timeslot number below those with priority 1:

- 1) the PDCH timeslot numbers assigned for downlink transfer including the downlink PACCH associated with an uplink transfer;
- 2) the PDCH timeslot numbers assigned for uplink transfer;
- 3) other timeslots that would be possible to add for downlink transfer to the current assignment according to the MSs multislot class. If more than one combination of timeslots is possible according to this rule, it is implementation dependent which combination to choose.

Interference measurement timeslots have lower priority than real receiver or transmit timeslot and are not compulsory in case of conflict.

For each channel, every measurement $SS_{CH,n}$ shall consist of the minimum of the two signal level samples from one search frame and one PTCCH frame. These two measurements should be spaced as closely as possible, but there is no requirement that they shall be contiguous. Thus the SACCH frames are avoided (except for a physical channel with two TCH/Hs) and only the interference is measured. As an exception in case of DTM, every measurement $SS_{CH,n}$ on the TCH timeslot shall consist of a signal level sample from one search frame only (since SACCH transmission on this slot cannot occur at the search frame). For COMPACT, for each channel, at least two interference measurement sample, $SS_{CH,n}$, shall be taken every multiframe.

The measured interference shall be averaged in a running average filter:

$$\gamma_{CH,n} = (1-d) * \gamma_{CH,n-1} + d * SS_{CH,n}, \gamma_{CH,0} = 0$$

where d is the forgetting factor:

$$d = 1/\text{MIN}(n, N_{\text{AVG}_I}).$$

n is the iteration index.

The filter shall be restarted with $n=1$ for the first sample when the MS enters packet transfer mode or MAC-Shared state or every time a new cell is selected. Channel reassignment during packet transfer mode or MAC-Shared state shall be considered as start of a new packet transfer mode or MAC-Shared state preceded by a zero length packet idle mode or MAC-Idle state.

For each channel, the MS shall perform at least N_{AVG_I} (rounded to the nearest integer) measurements of $SS_{CH,n}$ before valid γ_{CH} values can be determined

During GPRS downlink TBF transfer, the MS shall measure the received signal quality as defined in subclause 8.2. The reported value, $RXQUAL$, shall be the average within the reporting period. Only successfully decoded blocks intended for that MS shall be included in the average. Alternatively, if CS4 only is used during the reporting period, the MS is allowed to report $RXQUAL = 7$. If CS-4 is used with other CS within a reporting period, the MS shall not take into account CS-4 blocks in the calculation of $RXQUAL$: the MS shall compute the average taking into account other CS only. If no block has been correctly decoded during the reporting period, the MS shall report $RXQUAL = 7$, whatever the used CS. The first reporting period starts with and includes the first assignment message for the downlink transfer. The reporting period ends, and the subsequent reporting starts, no earlier than two blocks before the transmission of a quality report and no later than one block before the transmission of a quality report. In averaging, measurements made during previous reporting periods shall always be discarded.

During EGPRS downlink TBF transfer, the MS shall measure the received signal quality as defined in subclause 8.2.

In BTTI configuration, the quality parameters shall be, for the radio blocks intended for this MS only (i.e. at least radio blocks where the TFI identifying this MS can be decoded from the RLC/MAC header and radio blocks where the TFI identifying this MS can be decoded from the RLC/MAC control block header: see 3GPP TS 44.060), individually averaged per channel (timeslot) and per modulation type as follows:

$$R_n = (1-e) \cdot R_{n-1} + e \cdot x_n, R_{-1} = 0$$

$$\text{MEAN_BEP_TN}_n = (1 - e \cdot \frac{x_n}{R_n}) \cdot \text{MEAN_BEP_TN}_{n-1} + e \cdot \frac{x_n}{R_n} \cdot \text{MEAN_BEP}_{\text{block}n}$$

$$\text{CV_BEP_TN}_n = (1 - e \cdot \frac{x_n}{R_n}) \cdot \text{CV_BEP_TN}_{n-1} + e \cdot \frac{x_n}{R_n} \cdot \text{CV_BEP}_{\text{block}n}$$

Where: n is the iteration index, incremented per each downlink radio block.

R_n denotes the reliability of the filtered quality parameters for the respective modulation type.

e is the forgetting factor defined below.

x_n denotes the existence of quality parameters for the n^{th} block for the respective modulation type, i.e. if the radio block is intended for this MS. x_n values 1 and 0 denote the existence and absence of quality parameters, respectively.

In RTTI configuration, the quality parameters shall be, for the radio blocks intended for this MS only (i.e. at least radio blocks where the TFI identifying this MS can be decoded from the RLC/MAC header and radio blocks where the TFI identifying this MS can be decoded from the RLC/MAC control block header: see 3GPP TS 44.060), individually averaged per channel (timeslot pair where TN is the lower numbered timeslot of the timeslot pair) and per modulation type as follows:

$$R_n = (1 - e) \cdot R_{n-1} + e \cdot \frac{x_{n,a} + x_{n,b}}{2}, \quad R_{-1} = 0$$

$$\text{MEAN_BEP_TN}_n = (1 - e \cdot \frac{x_{n,a} + x_{n,b}}{2R_n}) \cdot \text{MEAN_BEP_TN}_{n-1} + e \cdot \frac{x_{n,a} \text{MEAN_BEP}_{\text{block},n,a} + x_{n,b} \text{MEAN_BEP}_{\text{block},n,b}}{2R_n}$$

$$\text{CV_BEP_TN}_n = (1 - e \cdot \frac{x_{n,a} + x_{n,b}}{2R_n}) \cdot \text{CV_BEP_TN}_{n-1} + e \cdot \frac{x_{n,a} \text{CV_BEP}_{\text{block},n,a} + x_{n,b} \text{CV_BEP}_{\text{block},n,b}}{2R_n}$$

Where: n is the iteration index, incremented per 20ms filtering.

R_n denotes the reliability of the filtered quality parameters for the respective modulation type for the n^{th} 20ms filtering.

e is the forgetting factor defined below.

$x_{n,a}$ denotes the existence of quality parameters for the first 10ms RTTI radio block in the n^{th} 20ms filtering for the respective modulation type, i.e. if the radio block is intended for this MS. $x_{n,a}$ values 1 and 0 denote the existence and absence of quality parameters, respectively.

$x_{n,b}$ denotes the existence of quality parameters for the second 10ms RTTI radio block in the n^{th} 20ms filtering for the respective modulation type, i.e. if the radio block is intended for this MS. $x_{n,b}$ values 1 and 0 denote the existence and absence of quality parameters, respectively.

MEAN_BEP_TN_n is the mean bit error probability of the timeslot-pair value of the n^{th} 20ms filtering.

CV_BEP_TN_n is the coefficient variation of the bit error probability of the timeslot-pair value of the n^{th} 20ms filtering.

$\text{MEAN_BEP}_{\text{block},n,a}$ is the mean bit error probability of the first 10ms RTTI radio block in the n^{th} 20ms filtering. $\text{CV_BEP}_{\text{block},n,a}$ is the coefficient variation of the bit error probability of the first 10ms RTTI radio block of the n^{th} 20ms filtering.

$\text{MEAN_BEP}_{\text{block},n,b}$ is the mean bit error probability of the second 10ms RTTI radio block in the n^{th} 20ms filtering. $\text{CV_BEP}_{\text{block},n,b}$ is the coefficient variation of the bit error probability of the second 10ms RTTI radio block of the n^{th} 20ms filtering.

In case BEP_PERIOD2 is received and with a field value different than 15, e shall be defined as e_2 according to BEP_PERIOD2 as shown in the table below. This allows for individual filtering per MS.

In case BEP_PERIOD2 is received and with the field value 15 (norm), e shall be defined as e_1 according to BEP_PERIOD as shown in the table below. This allows for normal filtering (non-individual). This BEP_PERIOD2 shall be used by the considered MS in the serving cell, until a new BEP_PERIOD2 is received by this MS in the same cell, or the MS leaves the cell or the MS enters packet idle mode or MAC-Idle state.

Field value	15	14	13	12	11	10	9	8	7	6	5	4	3	2	1	0
BEP_PERIOD	Reserved					25	20	15	12	10	7	5	4	3	2	1
e_1	-					0.08	0.1	0.15	0.2	0.25	0.3	0.4	0.5	0.65	0.8	1
BEP_PERIOD2	Norm	90	70	55	40	25	20	15	12	10	7	5	4	3	2	1
e_2	e_1	0.03	0.04	0.05	0.065	0.08	0.1	0.15	0.2	0.25	0.3	0.4	0.5	0.65	0.8	1

BEP_PERIOD2 is sent to individual MS on PACCH D/L. See 3GPP TS 44.060.

BEP_PERIOD is broadcast on PBCCH or, if PBCCH does not exist, on BCCH.

An MS shall calculate the overall MEAN_BEP, and CV_BEP per modulation type as average over all assigned channels (timeslots) irrespective whether blocks were received on a channel (timeslot or timeslot pair where TN is the lower numbered timeslot of the timeslot pair) since it last sent a measurement report to the network as follows :

$$\text{MEAN_BEP}_n = \frac{\sum_j R_n^{(j)} \cdot \text{MEAN_BEP_TN}_n^{(j)}}{\sum_j R_n^{(j)}}$$

$$\text{CV_BEP}_n = \frac{\sum_j R_n^{(j)} \cdot \text{CV_BEP_TN}_n^{(j)}}{\sum_j R_n^{(j)}}$$

where n = the iteration index at reporting time

j = the channel number.

When entering packet transfer mode or MAC-Shared state and/or when selecting a new cell, the filters shall reset the values of n to 0. When a new channel (timeslot or timeslot pair) is assigned for a downlink TBF, the filters shall reset the values of MEAN_BEP_TN_{n-1} , CV_BEP_TN_{n-1} and R_{n-1} to 0 for this channel (timeslot or timeslot pair where TN is the lower numbered timeslot of the timeslot pair). If frequency hopping is used, channels that only differ in MAIO shall not be considered new in this context.

The reporting period ends no earlier than two blocks for a GPRS TBF mode and three blocks for an EGPRS TBF mode before the transmission of a quality report and no later than one block before the transmission of a quality report.

$N_{\text{AVG_I}}$ is broadcast on PBCCH or, if PBCCH does not exist, on BCCH or CPBCCH or optionally sent to mobile station in an RLC/MAC control message (see 3GPP TS 44.060).

10.2.3.2.2 Void

10.2.3.2.3 Measurement reporting

A MS using GPRS shall transfer γ_{CH} values and the RXQUAL, C and SIGN_VAR values (see subclause 10.2.3.1.2) to the network in the Channel Quality Report on PACCH. An MS using EGPRS or EGPRS2 shall instead of RXQUAL and SIGN_VAR send MEAN_BEP and CV_BEP.

In case of EGPRS the MS shall report the overall MEAN_BEP and CV_BEP for the modulations, GMSK and/or 8-PSK (i.e. GMSK_MEAN_BEP, GMSK_CV_BEP; and/or 8PSK_MEAN_BEP, 8PSK_CV_BEP respectively) for which it has received blocks on at least one allocated channel (timeslot or timeslot pair) since it last sent a measurement report to the network.

Additionally, in case of EGPRS, the MS shall report MEAN_BEP_TN_x on a per timeslot basis in BTTI configuration, or on a per timeslot pair basis in RTTI configuration where TN_x is the lower numbered timeslot of the timeslot pair according to what the network has ordered (see 3GPP TS 44.060). An MS shall only include MEAN_BEP_TN_x values for the modulation scheme with which it has received the larger number of blocks on its currently assigned channels (timeslots or timeslot pairs) since it last sent a measurement report to the network.

In case of EGPRS2 downlink the MS shall report the MEAN_BEP and CV_BEP for up to two modulation schemes for all timeslots in the TBF using the EGPRS BEP Link Quality Measurements Type 2 IE (see 3GPP TS 44.060). The selection of the modulation schemes to report is based on the blocks which it has received since it last sent a measurement report to the network.

In the case of EGPRS2-A downlink, the MS shall report the MEAN_BEP and CV_BEP only for the two modulation schemes with the highest number of received blocks, not including RLC/MAC control blocks. If an equal number of blocks have been received for two or more modulation schemes that are subject to reporting, the selection of which of these modulation schemes to report is implementation dependent.

In the case of EGPRS2-B downlink, the MS shall report the MEAN_BEP and CV_BEP for the (at most two) modulation schemes with the highest non-zero values of N_BLOCKS_WEIGHTED, where :

- $N_BLOCKS_WEIGHTED = 2 \times N_BLOCKS$, if the modulation scheme is 'preferred',
- otherwise, $N_BLOCKS_WEIGHTED = \min(N_BLOCKS, BEP_PERIOD2, RP/2)$, if $BEP_PERIOD2$ has been received by the mobile station or $N_BLOCKS_WEIGHTED = \min(N_BLOCKS, BEP_PERIOD, RP/2)$ if $BEP_PERIOD2$ has not been received by the mobile station,
- N_BLOCKS is the number of blocks using the modulation scheme that were received with a TFI value associated with a TBF corresponding to the mobile station since the previous report, not including RLC/MAC control blocks,
- RP is the number of basic radio block periods that have elapsed since the previous report (i.e. the previous instance of the EGPRS BEP Link Quality Measurements Type 2 IE) was transmitted,
- EGPRS2-B modulation schemes which are 'preferred' are: GMSK, QPSK, 16-QAM HSR and 32-QAM HSR.

In case two or more modulation schemes that are subject to reporting have an equal value of $N_BLOCKS_WEIGHTED$, the modulation scheme with higher N_BLOCKS shall be reported in preference. If these modulation schemes have also equal values of N_BLOCKS , the selection of which of these modulation schemes to report is implementation dependent.

If fewer than two modulation schemes other than GMSK have non-zero values of $N_BLOCKS_WEIGHTED$ and one or more RLC/MAC control blocks with a TFI value associated with a TBF corresponding to the mobile station were received since the previous report, the MS shall also report the link quality for GMSK.

Additionally, in case of EGPRS2, if commanded by the network according to the `LINK_QUALITY_MEASUREMENT_MODE` field, the MS shall report both `MEAN_BEP_TNx` and `REPORTED_MODULATION` on a per timeslot (in BTTI configuration) or timeslot pair (in RTTI configuration where TNx is the lower number timeslot of the timeslot pair) basis as specified in the EGPRS Timeslot Link Quality Measurements Type 2 IE. More specifically, for each of its currently assigned timeslots or timeslot pairs, an MS shall report the modulation scheme (indicated using the `REPORTED_MODULATION` field) with which it has received the greatest number of blocks since the last report and shall report the `MEAN_BEP_TNx` of that modulation scheme (see 3GPP TS 44.060). In case there are more than one modulation scheme having the same number and the largest number of blocks on a currently assigned timeslot, the MS shall report the `MEAN_BEP_TNx` for the highest order modulation scheme among those modulation schemes on that timeslot.

The report contains the available γ_{CH} values for the radio frequency channel on which the message is sent as well as the `RXQUAL`, `C` and `SIGN_VAR` values (see subclause 10.2.3.1.2) or in case of EGPRS and EGPRS2 the `MEAN_BEP`, `C` and `CV_BEP` values, except for a downlink dual carrier assignment.

The conditions for including the different values, which are not always mandatory, are specified in 3GPP TS 44.060. The mapping of γ_{ch} to the reported `I_LEVEL` value is defined in subclause 10.3.

10.2.3.2.4 Measurement reporting - additional requirements for downlink dual carrier

In case of a downlink dual carrier assignment, the γ_{CH} , `C`, `MEAN_BEP` (overall and per timeslot or timeslot pair measurements) and `CV_BEP` values may be reported for each of the radio frequency channels as specified in 3GPP TS 44.060.

If the required set of the measurements (overall `MEAN_BEP` and `CV_BEP`, `MEAN_BEP_TNx` measurements and / or γ_{ch}) to be reported for a given carrier as specified in sub-clause 10.2.3.2.3 does not fit in the message used for sending the measurements (see 3GPP TS 44.060) and would otherwise include the overall `MEAN_BEP` and `CV_BEP` for two candidate modulations, the mobile station shall, for the corresponding carrier, only send the overall `MEAN_BEP` and `CV_BEP` for a single modulation, selected as follows:

- in case of EGPRS or EGPRS2-A, the modulation scheme for which it has received the highest number of blocks since it last sent a measurement report; if an equal number of blocks have been received for the two candidate modulation schemes, the selection of which of these modulation schemes to report is implementation dependent;
- in case of EGPRS2-B, the modulation scheme with the highest non zero value of $N_BLOCKS_WEIGHTED$; if the two candidate modulation schemes have equal non zero value of $N_BLOCKS_WEIGHTED$, the modulation scheme with higher N_BLOCKS shall be reported in preference; if these two modulation schemes have also equal values of N_BLOCKS , the selection of which of these modulation schemes to report is implementation dependent.

In addition, when not all MEAN_BEP_TNx measurements can be included in the message used for reporting the measurements, the selection of the timeslots for which MEAN_BEP_TNx measurements are included is left implementation dependent.

10.2.3.3 Range of parameters MEAN_BEP and CV_BEP for EGPRS2

The mapping of the MEAN_BEP to the equivalent BEP and the accuracies to which an MS shall be capable of estimating the quality parameters under static channel conditions are given in the following tables for EGPRS2-A DL (16-QAM and 32-QAM) and for EGPRS2-B DL (QPSK, 16-QAM and 32-QAM) respectively. The accuracy requirements below apply for sensitivity limited operation for signal levels above the reference sensitivity level for the type of MS, assuming no changes in transmitted downlink power. The requirements apply for PDTCH/F in *A/Gb mode*, and the estimated values are averaged applying filtering according to subclause 10.2.3.2.1 with forgetting factor of 0.03.

MEAN_BEP mapping and accuracy for QPSK (EGPRS2-B)

MEAN_BEP	Range of log ₁₀ (actual BEP)	Expected MEAN_BEP interval	Probability that the expected MEAN_BEP is reported shall not be lower than see NOTE *):
MEAN_BEP_0	[> -0.60]	MEAN_BEP_0/1	tbd
MEAN_BEP_1	[-0.70 -- -0.60]	MEAN_BEP_1/0/2	tbd
MEAN_BEP_2	[-0.80 -- -0.70]	MEAN_BEP_2/1/3	tbd
MEAN_BEP_3	[-0.90 -- -0.80]	MEAN_BEP_3/2/4	tbd
MEAN_BEP_4	[-1.00 -- -0.90]	MEAN_BEP_4/3/5	tbd
MEAN_BEP_5	[-1.10 -- -1.00]	MEAN_BEP_5/4/6	tbd
MEAN_BEP_6	[-1.20 -- -1.10]	MEAN_BEP_6/5/7	tbd
MEAN_BEP_7	[-1.30 -- -1.20]	MEAN_BEP_7/6/8	tbd
MEAN_BEP_8	[-1.40 -- -1.30]	MEAN_BEP_8/7/9	tbd
MEAN_BEP_9	[-1.50 -- -1.40]	MEAN_BEP_9/8/10	tbd
MEAN_BEP_10	[-1.60 -- -1.50]	MEAN_BEP_10/9/11	tbd
MEAN_BEP_11	[-1.70 -- -1.60]	MEAN_BEP_11/10/12	tbd
MEAN_BEP_12	[-1.80 -- -1.70]	MEAN_BEP_12/11/13	tbd
MEAN_BEP_13	[-1.90 -- -1.80]	MEAN_BEP_13/12/14	tbd
MEAN_BEP_14	[-2.00 -- -1.90]	MEAN_BEP_14/13/15	tbd
MEAN_BEP_15	[-2.10 -- -2.00]	MEAN_BEP_15/13/14/16/17	tbd
MEAN_BEP_16	[-2.20 -- -2.10]	MEAN_BEP_16/14/15/17/18	tbd
MEAN_BEP_17	[-2.30 -- -2.20]	MEAN_BEP_17/15/16/18/19	tbd
MEAN_BEP_18	[-2.40 -- -2.30]	MEAN_BEP_18/16/17/19/20	tbd
MEAN_BEP_19	[-2.50 -- -2.40]	MEAN_BEP_19/17/18/20/21	tbd
MEAN_BEP_20	[-2.60 -- -2.50]	MEAN_BEP_20/18/19/21/22	tbd
MEAN_BEP_21	[-2.70 -- -2.60]	MEAN_BEP_21/19/20/22/23	tbd
MEAN_BEP_22	[-2.80 -- -2.70]	MEAN_BEP_22/20/21/23/24	tbd
MEAN_BEP_23	[-2.90 -- -2.80]	MEAN_BEP_23/21/22/24/25	tbd
MEAN_BEP_24	[-3.00 -- -2.90]	MEAN_BEP_24/22/23/25/26	tbd
MEAN_BEP_25	[-3.10 -- -3.00]	MEAN_BEP_25/22/23/24/26/27/28	tbd
MEAN_BEP_26	[-3.20 -- -3.10]	MEAN_BEP_26/23/24/25/27/28/29	tbd
MEAN_BEP_27	[-3.30 -- -3.20]	MEAN_BEP_27/24/25/26/28/29/30	tbd
MEAN_BEP_28	[-3.40 -- -3.30]	MEAN_BEP_28/25/26/27/29/30/31	tbd
MEAN_BEP_29	[-3.50 -- -3.40]	MEAN_BEP_29/26/27/28/30/31	tbd
MEAN_BEP_30	[-3.60 -- -3.50]	MEAN_BEP_30/27/28/29/31	tbd
MEAN_BEP_31	[< -3.60]	MEAN_BEP_31/28/29/30	tbd
NOTE *) The values in this column apply for PDTCH/F in <i>A/Gb mode</i> .			

MEAN_BEP mapping and accuracy for 16-QAM (EGPRS2-A and EGPRS2-B)

MEAN_BEP	Range of log ₁₀ (actual BEP)	Expected MEAN_BEP interval	Probability that the expected MEAN_BEP for EGPRS2-A is reported shall not be lower than see NOTE *):	Probability that the expected MEAN_BEP for EGPRS2-B is reported shall not be lower than see NOTE *):
MEAN_BEP_0	[> -0.60]	MEAN_BEP_0/1/2	90 %	tbd
MEAN_BEP_1	[-0.64 -- -0.60]	MEAN_BEP_1/0/2/3	90 %	tbd
MEAN_BEP_2	[-0.68 -- -0.64]	MEAN_BEP_2/0/1/3/4	90 %	tbd
MEAN_BEP_3	[-0.72 -- -0.68]	MEAN_BEP_3/1/2/4/5	90 %	tbd
MEAN_BEP_4	[-0.76 -- -0.72]	MEAN_BEP_4/2/3/5/6	90 %	tbd
MEAN_BEP_5	[-0.80 -- -0.76]	MEAN_BEP_5/3/4/6/7	90 %	tbd
MEAN_BEP_6	[-0.84 -- -0.80]	MEAN_BEP_6/4/5/7/8	90 %	tbd
MEAN_BEP_7	[-0.88 -- -0.84]	MEAN_BEP_7/5/6/8/9	90 %	tbd
MEAN_BEP_8	[-0.92 -- -0.88]	MEAN_BEP_8/6/7/9/10	90 %	tbd
MEAN_BEP_9	[-0.96 -- -0.92]	MEAN_BEP_9/7/8/10/11	90 %	tbd
MEAN_BEP_10	[-1.00 -- -0.96]	MEAN_BEP_10/8/9/11/12	90 %	tbd
MEAN_BEP_11	[-1.04 -- -1.00]	MEAN_BEP_11/9/10/12/13	90 %	tbd
MEAN_BEP_12	[-1.08 -- -1.04]	MEAN_BEP_12/10/11/13/14	90 %	tbd
MEAN_BEP_13	[-1.12 -- -1.08]	MEAN_BEP_13/11/12/14/15	90 %	tbd
MEAN_BEP_14	[-1.16 -- -1.12]	MEAN_BEP_14/12/13/15/16	90 %	tbd
MEAN_BEP_15	[-1.20 -- -1.16]	MEAN_BEP_15/13/14/16	90 %	tbd
MEAN_BEP_16	[-1.36 -- -1.20]	MEAN_BEP_16/14/15/17	90 %	tbd
MEAN_BEP_17	[-1.52 -- -1.36]	MEAN_BEP_17/16/18	90 %	tbd
MEAN_BEP_18	[-1.68 -- -1.52]	MEAN_BEP_18/17/19	90 %	tbd
MEAN_BEP_19	[-1.84 -- -1.68]	MEAN_BEP_19/18/20	90 %	tbd
MEAN_BEP_20	[-2.00 -- -1.84]	MEAN_BEP_20/19/21	90 %	tbd
MEAN_BEP_21	[-2.16 -- -2.00]	MEAN_BEP_21/20/22	90 %	tbd
MEAN_BEP_22	[-2.32 -- -2.16]	MEAN_BEP_22/21/23	90 %	tbd
MEAN_BEP_23	[-2.48 -- -2.32]	MEAN_BEP_23/22/24	90 %	tbd
MEAN_BEP_24	[-2.64 -- -2.48]	MEAN_BEP_24/23/25	90 %	tbd
MEAN_BEP_25	[-2.80 -- -2.64]	MEAN_BEP_25/23/24/26/27	90 %	tbd
MEAN_BEP_26	[-2.96 -- -2.80]	MEAN_BEP_26/24/25/27/28	90 %	tbd
MEAN_BEP_27	[-3.12 -- -2.96]	MEAN_BEP_27/25/26/28/29	90 %	tbd
MEAN_BEP_28	[-3.28 -- -3.12]	MEAN_BEP_28/26/27/29/30	90 %	tbd
MEAN_BEP_29	[-3.44 -- -3.28]	MEAN_BEP_29/27/28/30/31	90 %	tbd
MEAN_BEP_30	[-3.60 -- -3.44]	MEAN_BEP_30/28/29/31	90 %	tbd
MEAN_BEP_31	[< -3.60]	MEAN_BEP_31/29/30	90 %	tbd

NOTE *) The values in this column apply for PDTCH/F in A/Gb mode.

MEAN_BEP mapping and accuracy for 32-QAM (EGPRS2-A and EGPRS2-B)

MEAN_BEP	Range of log10(actual BEP)	Expected MEAN_BEP interval	Probability that the expected MEAN_BEP for EGPRS2-A is reported shall not be lower than see NOTE *):	Probability that the expected MEAN_BEP for EGPRS2-B is reported shall not be lower than see NOTE *):
MEAN_BEP_0	[> -0.60]	MEAN_BEP_0/1/2	90 %	tbd
MEAN_BEP_1	[-0.64 -- -0.60]	MEAN_BEP_1/0/2/3	90 %	tbd
MEAN_BEP_2	[-0.68 -- -0.64]	MEAN_BEP_2/0/1/3/4	90 %	tbd
MEAN_BEP_3	[-0.72 -- -0.68]	MEAN_BEP_3/1/2/4/5	90 %	tbd
MEAN_BEP_4	[-0.76 -- -0.72]	MEAN_BEP_4/2/3/5/6	90 %	tbd
MEAN_BEP_5	[-0.80 -- -0.76]	MEAN_BEP_5/3/4/6/7	90 %	tbd
MEAN_BEP_6	[-0.84 -- -0.80]	MEAN_BEP_6/4/5/7/8	90 %	tbd
MEAN_BEP_7	[-0.88 -- -0.84]	MEAN_BEP_7/5/6/8/9	90 %	tbd
MEAN_BEP_8	[-0.92 -- -0.88]	MEAN_BEP_8/6/7/9/10	90 %	tbd
MEAN_BEP_9	[-0.96 -- -0.92]	MEAN_BEP_9/7/8/10/11	90 %	tbd
MEAN_BEP_10	[-1.00 -- -0.96]	MEAN_BEP_10/8/9/11/12	90 %	tbd
MEAN_BEP_11	[-1.04 -- -1.00]	MEAN_BEP_11/9/10/12/13	90 %	tbd
MEAN_BEP_12	[-1.08 -- -1.04]	MEAN_BEP_12/10/11/13/14	90 %	tbd
MEAN_BEP_13	[-1.12 -- -1.08]	MEAN_BEP_13/11/12/14/15	90 %	tbd
MEAN_BEP_14	[-1.16 -- -1.12]	MEAN_BEP_14/12/13/15/16	90 %	tbd
MEAN_BEP_15	[-1.20 -- -1.16]	MEAN_BEP_15/13/14/16	90 %	tbd
MEAN_BEP_16	[-1.36 -- -1.20]	MEAN_BEP_16/14/15/17	90 %	tbd
MEAN_BEP_17	[-1.52 -- -1.36]	MEAN_BEP_17/16/18	90 %	tbd
MEAN_BEP_18	[-1.68 -- -1.52]	MEAN_BEP_18/17/19	90 %	tbd
MEAN_BEP_19	[-1.84 -- -1.68]	MEAN_BEP_19/18/20	90 %	tbd
MEAN_BEP_20	[-2.00 -- -1.84]	MEAN_BEP_20/19/21	90 %	tbd
MEAN_BEP_21	[-2.16 -- -2.00]	MEAN_BEP_21/20/22	90 %	tbd
MEAN_BEP_22	[-2.32 -- -2.16]	MEAN_BEP_22/21/23	90 %	tbd
MEAN_BEP_23	[-2.48 -- -2.32]	MEAN_BEP_23/22/24	90 %	tbd
MEAN_BEP_24	[-2.64 -- -2.48]	MEAN_BEP_24/23/25	90 %	tbd
MEAN_BEP_25	[-2.80 -- -2.64]	MEAN_BEP_25/23/24/26/27	90 %	tbd
MEAN_BEP_26	[-2.96 -- -2.80]	MEAN_BEP_26/24/25/27/28	90 %	tbd
MEAN_BEP_27	[-3.12 -- -2.96]	MEAN_BEP_27/25/26/28/29	90 %	tbd
MEAN_BEP_28	[-3.28 -- -3.12]	MEAN_BEP_28/26/27/29/30	90 %	tbd
MEAN_BEP_29	[-3.44 -- -3.28]	MEAN_BEP_29/27/28/30/31	90 %	tbd
MEAN_BEP_30	[-3.60 -- -3.44]	MEAN_BEP_30/28/29/31	90 %	tbd
MEAN_BEP_31	[< -3.60]	MEAN_BEP_31/29/30	90 %	tbd

NOTE *) The values in this column apply for PDTCH/F in A/Gb mode.

For a coding on 4 bits, i.e. for timeslot based EGPRS2 link quality reports, the 4 most significant bits are used.

NOTE1: MEAN_BEP is calculated and filtered according to the procedure described in section 10.2.3.2.1.

NOTE2: The accuracy requirements above take into account possible fluctuations of the bit error rate due to adaptiveness of receivers.

NOTE3: Testing requires measurement of the actual bit error rate and assessment of MEAN_BEP reports based on the same period of time.

The mapping table for the coefficient of variation of the channel quality is defined as follows for QPSK, 16-QAM and 32-QAM:

CV_BEP 0	2.00	> CV_BEP >	1.75
CV_BEP 1	1.75	> CV_BEP >	1.50
CV_BEP 2	1.50	> CV_BEP >	1.25
CV_BEP 3	1.25	> CV_BEP >	1.00
CV_BEP 4	1.00	> CV_BEP >	0.75
CV_BEP 5	0.75	> CV_BEP >	0.50
CV_BEP 6	0.50	> CV_BEP >	0.25

CV_BEP 7 0.25 > CV_BEP > 0.00

The accuracy requirements for CV_BEP need not be specified since they are directly linked to those for MEAN_BEP. Nevertheless, the CV_BEP measured at the MS shall be the one used by this MS.

10.2.4 Measurements at BSS side

A procedure shall be implemented in the BSS to monitor the uplink Rx signal level and quality on each uplink PDCH, active as well as inactive.

The BSS shall also measure the Rx signal level and the quality of a specific MS packet transfer.

10.2a Packet-switched Handover

If an MS receives a packet-switched handover command towards a GSM cell which it is not synchronised to, then the MS shall search for synchronisation information up to 300 ms. In case of failure, the MS shall indicate a packet cell change failure (see 3GPP TS 44.060).

If a multi-RAT MS receives a packet-switched handover command towards a not known cell (see 3GPP TS 25.133 and 3GPP TS 25.123 for UTRAN or 3GPP TS 36.133 for E-UTRAN), then the multi-RAT MS shall search for synchronisation information up to 800 ms. In case of failure, the multi-RAT MS shall indicate a packet cell change failure (see 3GPP TS 44.060).

Details of the synchronization mechanisms appear in 3GPP TS 45.010.

10.3 Measurement requirements

The accuracy of the received signal level and interference measurements shall be as defined in subclause 8.1.2. For COMPACT, the accuracy of the interference estimate, which is based upon received signal level during a PDTCH/PACCH block (see Annex C), is ± 2 dB in addition to the accuracy of the received signal level defined in subclause 8.1.2 without downlink power control activated on the serving cell. The measured signal strength values shall be mapped to the reported C values as defined for RXLEV in subclause 8.1.4. If included in a PACKET DOWNLINK ACK/NACK or a PACKET RESOURCE REQUEST message, the measured interference level, γ_{CH} , shall be mapped to a reported I_LEVEL value between 0 and 15, relative to reported C value as follows:

- I_LEVEL 0 = interference level is greater than C
- I_LEVEL 1 = interference level is less than or equal to C and greater than C - 2 dB
- I_LEVEL 2 = interference level is less than or equal to C - 2 dB and greater than C - 4 dB
- :
- :
- I_LEVEL 14 = interference level is less than or equal to C - 26 dB and greater than C - 28 dB
- I_LEVEL 15 = interference level is less than or equal to C - 28 dB

10.4 Control parameters

A non-exhaustive list of parameters employed to control the radio links for GPRS are shown in table 3.

Table 3: Radio sub-system link control parameters for GPRS
((s) and (n) denote serving cell and non-serving cell respectively)

Parameter name	Description	Range	Bits	Channel
BA(GPRS)	BCCH Allocation for GPRS re-selection Note: If PBCCH does not exist, BA(GPRS) = BA(BCCH)	-	-	PBCCH D/L
BSIC(s+n)	Base station Identification Code for carriers in BA(GPRS) and the serving BCCH carrier	0-63	6	PBCCH D/L (**)
MS_TXPWR_MAX_CCH	See table 1.	0-31	5	BCCH D/L
POWER_OFFSET(s)	See table 1.	0-3	2	BCCH D/L
RXLEV_ACCESS_MIN	See table 1.	0-63	6	BCCH D/L
GPRS_MS_TXPWR_MAX_CCH(s+n)	The maximum TX power level an MS may use when accessing the system	0-31	5	PBCCH D/L
LB_MS_TXPWR_MAX_CCH(s)	The maximum allowed TX power level for GPRS access on the serving cell, on all other than DCS 1800 and PCS 1900 frequency bands. 0 = 43 dBm, 1 = 41 dBm, 2 = 39 dBm, ..., 18 = 7 dBm, 19 = 5 dBm, 20 = 5 dBm, ..., 31 = 5 dBm.	0-31	5	BCCH D/L PBCCH D/L PCCCH D/L PACCH D/L
GPRS_RXLEV_ACCESS_MIN(s+n)	Minimum received signal level at the MS required for access to the system.	0-63	6	PBCCH D/L
GPRS_RESELECT_OFFSET (n)	Applies an offset and hysteresis to the C32 re- selection criterion. -52, -48, ..., -12, -10, ..., 12, 16, ..., 48 dB	0-31	5	PBCCH D/L
PRIORITY_CLASS (s+n)	The HCS priority for the cells	0-7	3	PBCCH D/L
LSA_ID (s+n)	The LSA identities for the cells			PBCCH D/L
HCS_THR(s+n)	HCS signal level threshold -110, -108, ..., -50, infinity dB	0-31	5	PBCCH D/L
GPRS_TEMPORARY_OFFSET(n)	Applies a negative offset to C32 for the duration of PENALTY_TIME. 0, 10, ..., 60 dB, infinity	0-7	3	PBCCH D/L
GPRS_PENALTY_TIME(n)	Gives the duration for which the temporary offset is applied. 10, 20, ..., 320 seconds	0-31	5	PBCCH D/L
GPRS_CELL_RESELECT_ HYSTERESIS	Additional hysteresis applied in GMM Ready state or RRC-Cell_Shared state for cells in the same RA. 0, 2, ..., 14 dB	0-7	3	PBCCH D/L
RA_RESELECT_HYSTERESIS	Additional hysteresis applied for cells in different RAs. 0, 2, ..., 14 dB	0-7	3	PBCCH D/L
CELL_RESELECT_HYSTERESIS	Additional hysteresis applied for cells in different RAs if PCCCH does not exist. See table 1.	0-7	3	BCCH D/L
C32_QUAL	Flag indicating an exception rule for GPRS_RESELECT_OFFSET	1/0	1	PBCCH D/L
C31_HYST	Flag indicating if hysteresis shall be applied to C31.	1/0	1	PBCCH D/L
MULTIBAND_REPORTING	The number of carriers from each frequency band that shall be included in the list of 6 strongest cells or in the measurement report.	0-3	2	PBCCH D/L BCCH D/L
α	Power control parameter 0, 0.1, ..., 1	0-10	4	PBCCH D/L PACCH D/L (**)
P _b	Power reduction used by BTS on PBCCH blocks, relatively to the output power used on BCCH 0, -2, ..., -30 dB	0-15	4	PBCCH D/L PACCH D/L
PC_MEAS_CHAN	Flag that indicates whether the downlink measurements for power control shall be made on BCCH or PDCH.	0/1	1	PBCCH D/L PACCH D/L (**)
T _{AVG_W}	Signal level filter period for power control in packet idle mode or MAC-Idle state $2^{(k/2)}/6$ multiframe, k = 0, 1, ..., 25	0-25	5	PBCCH D/L PACCH D/L (**)
T _{AVG_T}	Signal level filter period for power control in packet transfer mode or MAC-Shared state $2^{(k/2)}/6$ multiframe, k = 0, 1, ..., 25	0-25	5	PBCCH D/L PACCH D/L (**)
N _{AVG_I}	Interference signal level filter constant for power control $2^{(k/2)}$, k = 0, 1, ..., 15	0-15	4	PBCCH D/L PACCH D/L (**)

(continued)

Table 3 (concluded): Radio sub-system link control parameters for GPRS

Parameter name	Description	Range	Bits	Channel
BEP_PERIOD	Filter constant for EGPRS Channel quality measurements. See subclause 10.2.3.2.1	0-15	4	PBCCH D/L (**)
BEP_PERIOD2	Filter constant for EGPRS Channel quality measurements. See subclause 10.2.3.2.1	0-15	4	PACCH D/L
NETWORK_CONTROL_ORDER	Controls cell re-selection and measurement reporting	0-3	2	PBCCH D/L PCCCH D/L PACCH D/L (**)
NC_FREQUENCY_LIST	Frequency list for cell re-selection measurement reporting	-	-	PCCCH D/L D/L
NC_REPORTING_PERIOD_I NC_REPORTING_PERIOD_T	Time period for measurement reporting 0.48, 0.96, 1.92, ..., 61.44 seconds	0-7	3	PBCCH D/L PCCCH D/L PACCH D/L (**)
NCC_PERMITTED	Bit map of NCC part of BSIC for which the MS shall report enhanced measurements.	-	8	PBCCH D/L PCCCH D/L PACCH D/L
SCALE	Indication of the offset, which applies for the reported RXLEV values. 0 = 0 dB, 1 = +10 dB	0-1	1	PACCH U/L
SCALE_ORD	Indication of the offset, which shall be used for the reported RXLEV values. 0 = +0 dB, 1 = + 10 dB, 2 = automatic Default value = 0 dB.	0-2	2	PBCCH D/L PCCCH D/L PACCH D/L (**)
CELL_BAR_ACCESS_2	See table 3b	0/1	1	PBCCH D/L
Qsearch_P	Search for UTRAN FDD cells if signal level below threshold (0-7): - 98, - 94, ... , - 74 dBm, ∞ (always) or above threshold (8-15): - 78, - 74, ... , - 54 dBm, ∞ (never). Default value = ∞ (never). Search for UTRAN TDD cells if signal level below threshold (0-7): - 98, - 94, ... , - 74 dBm, ∞ (always) or above threshold (8-15): - 90, - 86, ... , -66 dBm, ∞ (never).	0-15	4	PBCCH D/L PCCCH D/L PACCH D/L (**) (See note 1)
FDD_GPRS_Qoffset	Applies an offset to RLA_P for UTRAN FDD cell re-selection, 0 = - ∞ (always select a cell if acceptable), 1 = -28 dB, 2 = -24 dB, ... , 15 = 28 dB. Default value = 0 dBm.	0-15	4	PBCCH D/L
TDD_GPRS_Qoffset	An absolute threshold of RSCP for UTRAN TDD cell re-selection, 0 = -105dBm, 1 = -102dBm, 2 = -99dBm, 3 = -96dBm, 4 = -93dBm, 5 = -90dBm, 6 = -87dBm, 7 = -84dBm, 8 = -81dBm, 9 = -78dBm, 10 = -75dBm, 11 = -72dBm, 12 = -69dBm, 13 = -66dBm, 14 = -63dBm, 15 = -60dBm. Default value = -90dBm.	0-15	4	PBCCH D/L
FDD_Qmin	A minimum threshold for Ec/No for UTRAN FDD cell re-selection, 0 = -20dB, 1 = -6dB, 2 = -18dB, 3 = -8dB, 4 = -16dB, 5 = -10dB, 6 = -14dB, 7 = -12dB. Default value = -12dB.	0-7	3	PBCCH D/L
FDD_Qmin_Offset	Applies an offset to FDD_Qmin value, 0 = 0 dB, 1 = 2 dB, 2 = 4 dB, 3 = 6 dB, 4 = 8 dB, 5 = 10 dB, 6 = 12 dB, 7 = 14 dB. Default value = 0 dB.	0-7	3	PBCCH D/L PCCCH D/L PACCH D/L (**)
FDD_RSCPmin	A minimum threshold of RSCP for UTRAN FDD cell re-selection, 0 = -114 dBm, 1 = -112 dBm, 2 = -110 dBm, 3 = -108 dBm, 4 = -106 dBm, 5 = -104 dBm, 6 = -102 dBm, 7 = -100 dBm, 8 = -98 dBm, 9 = -96 dBm, 10 = -94 dBm, 11 = -92 dBm, 12 = -	0-15	4	PBCCH D/L PCCCH D/L PACCH D/L (**)

	90 dBm, 13 = -88 dBm, 14 = -86 dBm, 15 = -84 dBm. Default value = -102 dBm.			
XXX_MULTIRAT_REPORTING	The number of cells from the access technology/mode XXX (one or more) that shall be included in the measurement report.	0-3	2	PBCCH D/L PCCCH D/L PACCH D/L (**)
SERVING_BAND_REPORTING	The number of cells from the GSM serving frequency band that shall be included in the measurement report. Default value = 3	0-3	2	PBCCH D/L PCCCH D/L PACCH D/L (**)
REPORT_TYPE	Indicates which report type the MS shall use, 0 = enhanced, 1 = normal. Default value = normal.	0/1	1	PBCCH D/L PCCCH D/L PACCH D/L (**)
REP_PRIORITY	Indicates the reporting priority per cell, 0 = normal, 1 = high Default value = normal	0/1	1	PBCCH D/L PCCCH D/L PACCH D/L (**)
REPORTING_RATE	Indicates the allowed reporting rate, 0 = normal, 1 = reduced	0/1	1	PBCCH D/L PCCCH D/L PACCH D/L (**)
INVALID_BSIC_REPORTING	Indicates if GSM cells with invalid BSIC and allowed NCC part may be reported, 0 = no, 1 = yes	0/1	1	PBCCH D/L PCCCH D/L PACCH D/L (**)
XXX_REPORTING_THRESHOLD	Apply priority reporting if the reported value is above threshold for GSM frequency band or access technology/mode XXX (one or more), 0, 6, ..., -36, ∞ (never). Default value = always.	0-7	3	PBCCH D/L PCCCH D/L PACCH D/L (**)
FDD_REPORTING_THRESHOLD_2	Reporting threshold for the CPICH parameter (Ec/No or RSCP) that is not reported according to FDD_REP_QUANT. Default value = 0 (disabled)	0-63	6	PBCCH D/L PCCCH D/L PACCH D/L (**)
XXX_REPORTING_OFFSET	Apply an offset to the reported value when prioritising the cells for reporting for GSM frequency band or access technology/mode XXX (one or more), 0, 6, ..., 42. Default value = 0.	0-7	3	PBCCH D/L PCCCH D/L PACCH D/L (**)
FDD_REP_QUANT	Indicates the reporting quantity for UTRAN FDD cells, 0 = RSCP, 1 = Ec/No	0/1	1	PBCCH D/L PCCCH D/L PACCH D/L (**)
RTD	The real time difference to other GSM cells, modulo 51 TDMA frames, step: 1 or 1/64 TDMA frame	0-50 or 0-3263	6 or 12	PBCCH D/L (**)
3G_BA_IND	Sequence number of 3G neighbour cell list and/or E-UTRAN neighbour cell list	0/1	1	PBCCH DL PCCCH D/L PACCH D/L (**)
THRESH_GSM_low	A threshold below which the MS is allowed to reselect to lower priority layers, 0 = 0 dB, 1 = 2 dB, 2 = 4 dB, ..., 13 = 26 dB, 14 = 28 dB, 15 = ∞ (always).	0-15	4	PACCH D/L (**)
THRESH_priority_search	A threshold for the serving cell that controls measurement of inter-RAT cells or frequencies of lower priority when the priority-based cell reselection algorithm is used, 0 = -98 dBm, 1 = -95 dBm, 2 = -92 dBm, ..., 13 = -59 dBm, 14 = -56 dBm, 15 = ∞ (always).	0-15	4	PACCH D/L (**)
GERAN_PRIORITY	Priority of GSM cells, 0 = lowest priority, ..., 7 = highest priority.	0-7	3	PACCH D/L (**)
UTRAN_QRXLEVMIN	Minimum required RX level for cells on the target UTRAN frequency (dBm), 0 = -119 dBm, 1 = -117 dBm, 2 = -115 dBm, ..., 30 = -59 dBm, 31 = -57 dBm.	0-31	5	PACCH D/L (**)

	Default value = -119 dBm.			
THRESH_UTRAN_high, THRESH_UTRAN_low	Reselection thresholds towards UTRAN FDD or TDD cells, 0 = 0 dB, 1 = 2 dB, 2 = 4 dB, 3 = 6 dB, ..., 30 = 60 dB, 31 = 62 dB. Default value of THRESH_UTRAN_low = value of THRESH_UTRAN_high.	0-31	5	PACCH D/L (**)
UTRAN_PRIORITY	Priority of a UTRAN frequency layer, 0 = lowest priority, ..., 7 = highest priority.	0-7	3	PACCH D/L (**)
E-UTRAN_QRXLEVMIN	Minimum required RX level for cells on the target E-UTRAN frequency (dBm), 0 = -140 dBm, 1 = -138 dBm, 2 = -136 dBm, ..., 30 = -80 dBm, 31 = -78 dBm. Default value = -140 dBm.	0-31	5	PACCH D/L (**)
THRESH_E-UTRAN_high, THRESH_E-UTRAN_low	Reselection thresholds towards E-UTRAN FDD or TDD cells, 0 = 0 dB, 1 = 2 dB, 2 = 4 dB, 3 = 6 dB, ..., 30 = 60 dB, 31 = 62 dB. Default value of THRESH_E-UTRAN_low = value of THRESH_E-UTRAN_high.	0-31	5	PACCH D/L (**)
E-UTRAN_PRIORITY	Priority of a E-UTRAN frequency layer, 0 = lowest priority, ..., 7 = highest priority.	0-7	3	PACCH D/L (**)
H_PRIO	Hysteresis used in the priority reselection algorithm, 0 = ∞ (rule disabled), 1 = 5 dB, 2 = 4 dB, 3 = 3 dB.	0-3	2	PACCH D/L (**)
T_reselection	Time hysteresis in the reselection algorithm, 0 = 5 sec, 1 = 10 sec, 2 = 15 sec, 3 = 20 sec. Default value = 0 (5 sec)	0-3	2	PACCH D/L (**)
E-UTRAN_REP_QUANT	Indicates the reporting quantity for E-UTRAN cells, 0 = RSRP, 1 = RSRQ	0/1	1	PACCH D/L (**)
E-UTRAN_FDD_REPORTING_THR ESHOLD_2	Reporting threshold for the parameter (RSRP or RSRQ) that is not reported according to E-UTRAN_REP_QUANT. Default value = 0 (disabled)	0-63	6	PACCH D/L (**)
E-UTRAN_TDD_REPORTING_T HRESHOLD_2	Reporting threshold for the parameter (RSRP or RSRQ) that is not reported according to E-UTRAN_REP_QUANT. Default value = 0 (disabled)	0-63	6	PACCH D/L (**)
E-UTRAN_FDD_MEASUREMENT _REPORT_OFFSET	Parameter used in the calculation of the value of the quantity (RSRP or RSRQ) that is reported according to E-UTRAN_REP_QUANT, when 3-bit reporting is used. For RSRP the mapping is as follows: 0 = -140 dBm, 1 = -139 dBm, 2 = -138 dBm, ..., 62 = -78 dBm, 63 = -77 dBm. For RSRQ the mapping is as follows: 0 = -19.5 dB, 1 = -19 dB, 2 = -18.5 dB, ..., 31 = -4 dB, 32 = -3.5 dB, 33 = -3 dB. Default value = 0.	0-63	6	PACCH D/L (**)
E-UTRAN_TDD_MEASUREMENT _REPORT_OFFSET	Parameter used in the calculation of the value of the quantity (RSRP or RSRQ) that is reported according to E-UTRAN_REP_QUANT, when 3-bit reporting is used. For RSRP the mapping is as follows: 0 = -140 dBm, 1 = -139 dBm, 2 = -138 dBm, ..., 62 = -78 dBm, 63 = -77 dBm. For RSRQ the mapping is as follows: 0 = -19.5 dB, 1 = -19 dB, 2 = -18.5 dB, ..., 31 = -4 dB, 32 = -3.5 dB, 33 = -3 dB. Default value = 0.	0-63	6	PACCH D/L (**)
REPORTING_GRANULARITY	Signals whether fine or coarse granularity is used in 3-bit reporting. For RSRP: 0 = 2 dB step size, 1 = 3 dB step size; for RSRQ: 0 = 1 dB step size, 1 = 2 dB	0/1	1	PACCH D/L (**)

	step size). Default value = 0.			
Qsearch_P_E-UTRAN	Search for E-UTRAN cells if signal level below threshold (0-7): - 98, - 94, ... , - 74 dBm, ∞ (always) or above threshold (8-15): - 78, - 74, ... , - 54 dBm, ∞ (never). Default value = ∞ (never).	0-15	4	PACCH D/L (**)
Measurement_Control_E-UTRAN	Frequency-specific search enabled 0 = never search 1 = use Qsearch_P_E-UTRAN	0/1	1	PACCH D/L
Measurement_Control_UTRAN	Frequency-specific search enabled 0 = never search 1 = use Qsearch_P	0/1	1	PACCH D/L
E-UTRAN_Qmin	Minimum required quality for cells on the target E-UTRAN frequency (dB), 0= -34dB, 1= -32dB, 2= -30dB, ..., 14= -6dB, 15= -4dB. Default value= -34dB.	0-15	4	PACCH D/L
E-UTRAN_RSRPmin	Minimum required RX level for cells on the target E-UTRAN frequency (dBm), 0 = -140 dBm, 1 = -138 dBm, 2 = -136 dBm, ..., 30 = -80 dBm, 31 = -78 dBm. Default value = -140 dBm.	0-31	5	PACCH D/L
E-UTRAN_QQUALMIN	Minimum required quality for cells on the target E-UTRAN frequency (dB), 0= -34dB, 1= -32dB, 2= -30dB, ..., 14= -6dB, 15= -4dB. Default value= -34dB.	0-15	4	PACCH D/L
THRESH_E-UTRAN_high_Q, THRESH_E-UTRAN_low_Q	Reselection thresholds towards E-UTRAN FDD or TDD cells, 0 = 0 dB, 1 = 1 dB, 2 = 2 dB, 3 = 3 dB, ..., 30 = 30 dB, 31 = 31 dB. Default value of THRESH_E-UTRAN_low_Q = value of THRESH_E-UTRAN_high_Q.	0-31	5	PACCH D/L
UTRAN_CSG_FDD_REPORTING_THRESHOLD	Reporting threshold for the reported value (Ec/No) for UTRAN FDD CSG cells, 0, 6, ... , 36, ∞ (never). Default value = same as the value of FDD_REPORTING_THRESHOLD if signalled and if FDD_REP_QUANT = 1; otherwise 4 (-12.5 dB \leq CPICH Ec/Io < -12 dB).	0-7	3	PACCH D/L (**)
UTRAN_CSG_FDD_REPORTING_THRESHOLD_2	Reporting threshold for the non-reported value (RSCP) for UTRAN FDD CSG cells, Default value = same as the value of FDD_REPORTING_THRESHOLD_2 if signalled and if FDD_REP_QUANT = 1; otherwise 6 (-110 dBm \leq CPICH RSCP < -109 dBm).	0-63	6	PACCH D/L (**)
UTRAN_CSG_TDD_REPORTING_THRESHOLD	Reporting threshold for the reported value (RSCP) for UTRAN TDD CSG cells, 0, 6, ... , 36, ∞ (never). Default value = TDD_REPORTING_THRESHOLD if signalled; otherwise 0.	0-7	3	PACCH D/L (**)
E-UTRAN_CSG_FDD_REPORTING_THRESHOLD	Reporting threshold for the reported value (RSRQ) for E-UTRAN FDD CSG cells, 0, 6, ... , 36, ∞ (never). Default value = same as the value of E-UTRAN_FDD_REPORTING_THRESHOLD if signalled and if E-UTRAN_REP_QUANT = 1; otherwise 3 (-11.0 dB \leq RSRQ < -10.5 dB).	0-7	3	PACCH D/L (**)
E-UTRAN_CSG_FDD_REPORTING_THRESHOLD_2	Reporting threshold for the non-reported value (RSRP) for E-UTRAN FDD CSG cells. Default value = same as the value of E-UTRAN_FDD_REPORTING_THRESHOLD_2 if signalled and if E-UTRAN_REP_QUANT = 1; otherwise 11 (-120 dBm \leq RSRP < -118 dBm).	0-63	6	PACCH D/L (**)

E- UTRAN_CSG_TDD_REPORTING_THRESHOLD	Reporting threshold for the reported value (RSRQ) for E-UTRAN TDD CSG cells, 0, 6, ..., 36, ∞ (never). Default value = same as the value of E-UTRAN_TDD_REPORTING_THRESHOLD if signalled and if E-UTRAN_REP_QUANT = 1; otherwise 3 (-11.0 dB ≤ RSRQ < -10.5 dB).	0-7	3	PACCH D/L (**)
E- UTRAN_CSG_TDD_REPORTING_THRESHOLD_2	Reporting threshold for the non-reported value (RSRP) for E-UTRAN TDD CSG cells, Default value = same as the value of E-UTRAN_TDD_REPORTING_THRESHOLD_2 if signalled and if E-UTRAN_REP_QUANT = 1; otherwise 11 (-120 dBm ≤ RSRP < -118 dBm).	0-63	6	PACCH D/L (**)

NOTE: (**) These parameters occur also on BCCH if PBCCH does not exist.

NOTE 1: If PBCCH does not exist, the MS shall perform cell re-selection according to the idle mode procedures defined in clause 6 (i.e. use parameter Qsearch_I). In case parameter Qsearch_P is broadcast on BCCH it shall be used according to clause 10 only if GPRS cell re-selection parameters for one or more cells are provided to the MS in a Packet Cell Change Order or Packet Measurement Order message.

NOTE 2: In case an optional parameter is not included in a point-to-point signalling message, the default value of that parameter shall replace any previously broadcast value, where applicable.

Table 3a: Conversion from idle mode to GPRS cell re-selection parameters

GPRS Parameter name	Conversion from idle mode parameters
GPRS_RXLEV_ACCESS_MIN	RXLEV_ACCESS_MIN
GPRS_MS_TXPWR_MAX_CCH	MS_TXPWR_MAX_CCH
C31	0
GPRS_RESELECT_OFFSET(n)	CELL_RESELECT_OFFSET(n) - CELL_RESELECT_OFFSET(s)
GPRS_TEMPORARY_OFFSET	TEMPORARY_OFFSET
GPRS_PENALTY_TIME	PENALTY_TIME
PRIORITY_CLASS	0
C31_HYST	0
C32_QUAL	0
GPRS_CELL_RESELECT_HYSTERESIS	CELL_RESELECT_HYSTERESIS
RA_RESELECT_HYSTERESIS	CELL_RESELECT_HYSTERESIS
XXX_GPRS_Qoffset	XXX_Qoffset
CELL_BAR_ACCESS_2	CELL_BAR_ACCESS
EXC_ACC	cell exclusive access support capability

NOTE: If PENALTY_TIME = 11111 for a cell, the sign of CELL_RESELECT_OFFSET shall be changed and TEMPORARY_OFFSET set to 0 for that cell.

Table 3b: Parameters affecting cell priority for cell selection and re-selection

CELL_BAR_ACCESS_2	Cell selection priority	Status for cell reselection
0	Normal	Normal
1	Barred	Barred

NOTE 1: A low priority cell is only selected if there are no suitable cells of normal priority (see 3GPP TS 43.022).

The conversion of the PENALTY_TIME into the GPRS_PENALTY_TIME shall be done by use of the timer values (e.g. PENALTY_TIME = 40s → GPRS_PENALTY_TIME = 2 = 40s). Similarly dB values shall be used for GPRS_RESELECT_OFFSET(n) conversion.

11 CTS mode tasks

11.1 CTS idle mode tasks

Whilst attempting to attach to a CTS-FP, a CTS-MS shall implement the CTS cell selection procedure described in 3GPP TS 43.022. This procedure makes use of measurements and sub-procedures described in this clause. The procedure ensures that the CTS-MS is CTS attached to a CTS cell from which it can reliably decode downlink data and where access to CTS service is allowed.

Whilst in CTS idle mode, the CTS-MS shall implement procedures reporting to the CTS-FP (AFA monitoring, BCCH detection and OFO measurement), described in 3GPP TS 43.022. These procedure makes use of measurements and sub-procedures described in this clause, and are used for the frequency control of the system, described in 3GPP TS 45.056 and 3GPP TS 45.010.

This clause makes use of terms defined in 3GPP TS 43.022.

For the purpose of CTS cell selection, the CTS-MS shall be capable of detecting and synchronizing to a CTSBCH carrier and read the CTSBCH-SB data at reference sensitivity level and reference interference levels as specified in 3GPP TS 45.005. A CTS-MS in CTS idle mode shall always fulfil the performance requirement specified in 3GPP TS 45.005 at levels down to reference sensitivity level or reference interference level.

For the purpose of CTS cell selection, the CTS-MS shall compute an average of received signal levels for the CTSBCH carrier. This quantity called 'received level average' shall be unweighted average of the received signal level measured in dBm. The accuracy of the signal level measurements for CTS cell selection and the other idle mode tasks shall be the same as for radio link measurements.

The tolerance on all the timing requirements in this subclause is $\pm 10\%$.

11.1.1 CTS cell selection

11.1.1.1 Synchronization and measurements for CTS cell selection

The CTS-MS shall store the CTSBCH ARFCN for each CTS-FP the CTS-MS is enrolled with.

In the modes where CTS cell selection is required (see 3GPP TS 43.022), for each CTS-FP the CTS-MS is enrolled with, the CTS-MS shall periodically attempt to synchronize to the stored CTSBCH carrier. When attempting to synchronize to the CTSBCH carrier, the CTS-MS shall attempt to detect the frequency correction burst of the CTSBCH-FB and when detected, to decode the synchronization burst of the CTSBCH-SB and read the CTSBCH-SB information. The CTS-MS shall calculate the received level average of the CTSBCH carrier, the averaging being based on at least five measurement samples taken on the CTSBCH bursts.

The maximum time allowed to synchronize to a CTSBCH carrier and read the CTSBCH-SB information shall be 5 seconds.

11.1.1.2 Initial synchronization of CTS-MS

In order to perform upper layer procedures, e.g. the enrolment of a CTS-MS (see 3GPP TS 44.056), a special procedure shall be implemented in the CTS-FP, by which the initial synchronisation of a CTS-MS with the CTS-FP is eased. This procedure of initial synchronisation of CTS-MS shall be triggered by the CTS upper layers.

The procedure consists in transmitting the CTSBCH in every TDMA frame with the following pattern :

```
if FN mod 52 = 25 then the CTSBCH-FB is transmitted
else
    if FN mod 2 = 0 then the CTSBCH-FB is transmitted
    if FN mod 2 = 1 then the CTSBCH-SB is transmitted
```

The first burst sent with this pattern shall be the next programmed CTSBCH-FB on the TDMA frame : FN mod 52 = 25. The above transmission pattern shall be repeated for a period of 120 52-multiframe. No CTSBCH shifting shall be allowed during the pattern: the CTSBCH timeslot number shall be the TNC, see 3GPP TS 45.002.

The CTS-MS shall attempt to synchronize to the CTSBCH transmitted with the above pattern. Once synchronized, the CTS-MS shall perform the non-hopping access procedure, e.g. for enrolment purpose (see 3GPP TS 44.056). Upon reception of the access request message by the CTS-FP, the pattern transmission shall be stopped.

11.1.2 Criterion for CTS cell selection

The path loss criterion parameter C1_CTS used for CTS cell selection is defined by:

$$C1_CTS = \text{Received Level Average} - \text{CTS_RXLEV_ACCESS_MIN}$$

where: CTS_RXLEV_ACCESS_MIN = Minimum received level at the CTS-MS required for access to the system; this parameter shall be given by the CTS-FP to CTS-MS during the enrolment procedure (see 3GPP TS 44.056) and shall be stored in the CTS-MS for each CTS-FP it is enrolled with. The parameter can be updated on request of the CTS-FP.

All values are expressed in dBm.

The path loss criterion (3GPP TS 43.022) is satisfied if $C1_CTS > 0$.

11.1.3 Monitoring of CTSBCH and CTSPCH

11.1.3.1 Monitoring of received signal level

Whilst in CTS idle mode, the CTS-MS shall measure the received signal level of the CTSBCH and shall calculate the received level average of the CTSBCH carrier, the averaging being a running average on at least five collected measurement samples and a maximum time of 11 seconds ($5 \cdot 9 \cdot 52$ frames). The criterion C2_CTS defined below shall be calculated every time the CTS-MS decodes the CTSBCH in its CTS paging group :

$$C2_CTS = C1_CTS + \text{CTS_CELL_RESELECT_OFFSET}$$

If the criterion C2_CTS falls below zero for a period of 15 seconds, the CTS-MS shall considered itself as de-attached with the CTS-FP and shall perform the CTS cell selection specified in subclause 11.1.1.

11.1.3.2 Downlink beacon failure

The downlink beacon failure criterion is based on the downlink beacon failure counter DBC. Whilst in CTS idle mode on a CTS cell, DBC shall be initialized to a value equal to the nearest integer to $90/N$ where N is the number of paging groups defined for the CTS-FP (see 3GPP TS 45.002 subclause 6.5.7). Thereafter, whenever the CTS-MS attempts to decode CTSBCH-SB information bits (see 3GPP TS 45.002): if the information bits are successfully decoded DBC is increased by 1, however never beyond the initial value, otherwise DBC is decreased by 4. When $DBC \leq 0$, a downlink beacon failure shall be declared.

If a downlink beacon failure occurs, the CTS-MS shall consider itself as de-attached with the CTS-FP and shall perform the CTS cell selection specified in subclause 11.1.1.

11.1.3.3 Downlink paging failure

The downlink paging failure criterion is based on the downlink paging failure counter DPC. Whilst in CTS idle mode on a CTS cell, DPC shall be initialized to a value equal to CTSPCH_DECOD (this parameter shall be given by the CTS-FP to the CTS-MS during the attachment procedure, see 3GPP TS 44.056). Thereafter, each time the CTS-MS is required to decode a paging message on the CTSPCH (see 3GPP TS 45.002 subclause 6.5.1 ix): if the paging message is not successfully decoded ($BFI = 1$) DPC is decreased by 1, otherwise DPC is re-initialized to CTSPCH_DECOD. When $DPC \leq 0$, a downlink paging failure shall be declared.

If a downlink paging failure occurs, the CTS-MS shall consider itself as de-attached with the CTS-FP and shall perform the CTS cell selection specified in subclause 11.1.1.

11.1.4 Procedures with reporting to the CTS-FP

Whilst in CTS idle mode, the CTS-FP may order to the CTS-MS to complete the procedures defined hereafter. The order for each procedure is sent to the CTS-MS during a dedicated connection (see 3GPP TS 44.056).

For each of the procedures, a maximum time of processing is allowed. When multiple procedures are ordered in a single dedicated connection, the results shall be ready to be reported to the CTS-FP when the time corresponding to the sum of the maximum time of each procedure has expired.

11.1.4.1 AFA monitoring

The reporting of the AFA monitoring procedure is used by the AFA algorithm for the frequency management of the CTS (see 3GPP TS 45.056).

The parameters sent by the CTS-FP to the CTS-MS in the AFA monitoring order message shall be a list of n carriers : AFA monitoring frequency list, AMFL(1,...,n), together with the number of AFA monitoring cycles NAMC to perform.

For each carrier of the AMFL, the CTS-MS shall perform NAMC basic measurements, where a basic measurement shall be the average received signal level on the 8 timeslots of the TDMA frame. The delay between two consecutive basic measurements shall be at least 5 seconds. The received interference level of the carrier shall be the maximum of the NAMC basic measurements.

The maximum processing time for this procedure shall be (NAMC x 10) seconds.

When ordered by the CTS-FP, the CTS-MS shall report in the next AFA monitoring report message a table of received interference level of the carrier of the AMFL, INTERF_LEV (1,...,n), together with the minimum of the numbers of performed AFA monitoring cycles, NAMC_REAL ; the procedure shall be stopped.

11.1.4.2 BCCH detection

The reporting of the BCCH detection procedure may be used by the CTS-FP by the AFA algorithm and for the OFO request.

The parameters sent by the CTS-FP to the CTS-MS in the BCCH detection message shall be a list of m carriers : BCCH detection frequency list, BDFL(1,..,m).

For each carrier of the list, the CTS-MS shall attempt to synchronize to it and decode the SCH. The BCCH detection shall be failed (BCCH not detected) if the CTS-MS fails to decode the SCH.

The procedure shall be completed in maximum (m x 10) seconds

When ordered by the CTS-FP, the CTS-MS shall report in the next BCCH detection report message a table of BCCH detection status of the carriers of the list, BCCH_DETECT (1, ..., m) ; the procedure shall be stopped.

11.1.4.3 Observed Frequency Offset (OFO) measurement

The reported OFO measurements shall be used by the CTS-FP to correct its frequency source (see 3GPP TS 45.010).

The parameters sent by the CTS-FP to the CTS-MS in the OFO measurement message shall be a list of k BCCH carriers : OFO measurement BCCH list, OMBL(1,...,k).

For each BCCH carrier of the list, the CTS-MS shall attempt to assess the frequency offset between the BCCH carrier and the CTS-FP. The measurement status shall be "failed" if an offset measurement accuracy better than 0.2 ppm cannot be ensured.

The procedure shall be completed in maximum (k x 15) seconds

When ordered by the CTS-FP, the CTS-MS shall report in the next OFO measurement report message the table of OFO measurements and measurement status of the BCCH carriers of the list : OFO_MEAS(1,...,k), OFO_STATUS(1, ...,k) ; the procedure shall be stopped.

11.2 Intra-cell handover

11.2.1 Overall process

The overall intra-cell handover process is implemented in the CTS-MS and CTS-FP. Measurement of radio subsystem downlink performance is made in the CTS-MS. These measurements are signalled to the CTS-FP for assessment. The CTS-FP measures the uplink performance for the CTS-MS being served. Initial assessment of the measurements in conjunction with defined thresholds and intra-cell handover strategy shall be performed in the CTS-FP.

11.2.2 CTS-MS measurement procedure

A procedure shall be implemented in the CTS-MS by which it monitors the downlink RX signal level and quality from its serving CTS cell. The requirements for the CTS-MS measurements are given in subclause 11.5.

11.2.3 CTS-FP measurement procedure

A procedure shall be implemented in the CTS-FP by which it monitors the uplink RX signal level and quality from each CTS-MS being served by the CTS cell.

11.2.4 Strategy

The intra-cell handover strategy employed by the CTS-FP for radio link control determines the handover decision that will be made based on the CTS measurement results reported by the CTS-MS and made by the CTS-FP, and on various parameters set for each CTS-FP.

Due to the Total Frequency Hopping applied to the traffic channels in CTS, intra-cell handover can only occur to a different timeslot of the CTS cell.

Intra-cell handover from one timeslot in the CTS cell to another timeslot in the same CTS cell will normally be performed if the CTS measurement results show a low RXQUAL, but a high RXLEV on the serving CTS cell. This indicates a degradation of quality caused by interference even though the CTS-MS is situated within the coverage area of the serving CTS cell. The intra-cell handover should provide a timeslot with a lower level of interference.

11.3 RF power control

11.3.1 Overall process

RF power control is employed to minimize the transmit power required by CTS-MS or CTS-FP whilst maintaining the quality of the radio links. By minimizing the transmit power levels, interference to co-channel users is reduced.

11.3.2 CTS-MS implementation

RF power control shall be implemented in the CTS-MS.

The power control level to be employed by the CTS-MS on the uplink channel is indicated by means of the power control information sent either in the layer 1 header of each SACCH message block (see 3GPP TS 44.004) on the corresponding downlink channel, or in a dedicated signalling block (see 3GPP TS 44.056).

The CTS-MS shall employ the most recently commanded power control level (parameter CTS_MS_TXPWR_REQUEST) for all transmitted bursts on either a TCH, FACCH or SACCH.

The CTS-MS shall confirm the power control level that it is currently employing in the SACCH L1 header on the uplink (parameter CTS_MS_TXPWR_CONF). The indicated value shall be the power control level actually used by the CTS-MS for the last burst of the previous SACCH period.

When accessing a cell on the ARCH (CTS access request) and before receiving the first power command during a communication on a TCH (after a CTS immediate assignment message), the CTS-MS shall use the power control level defined by the CTS_MS_MAX_TXPWR parameters ; this parameters shall be given by the CTS-FP to the CTS-MS during the enrolment procedure, and can be updated on request of the CTS-FP.

If a power control level defined in 3GPP TS 45.005 is received but the level is not supported by the CTS-MS, the CTS-MS shall use the supported output power which is closest to the output power indicated by the received power control level.

11.3.3 CTS-MS power control range

The range over which a CTS-MS shall be capable of varying its RF output power shall be from its maximum authorized output power CTS_MS_MAX_TXPWR, down its lowest nominal output power (as defined in 3GPP TS 45.005), in steps of nominally 2 dB.

3GPP TS 45.005 gives a detailed definition of the RF power level step size and tolerances for a CTS-MS.

11.3.4 CTS-FP implementation

RF power control shall be implemented in the CTS-FP.

11.3.5 CTS-FP power control range

The range over which a CTS-FP shall be capable of varying its RF output power shall be from its maximum authorized output power CTS_FP_MAX_TXPWR down its lowest nominal output power (as defined in 3GPP TS 45.056), in steps of nominally 2 dB.

3GPP TS 45.056 gives a detailed definition of the RF power level step size and tolerances for a CTS-FP.

11.3.6 Strategy

The RF power control strategy employed by the CTS-FP determines the ordered power control level that is signalled to the CTS-MS, and the power control level that is employed by the CTS-FP.

The power control level to be employed in each case shall be based on the CTS measurement results reported by the CTS-MS and made by the CTS-FP, and on various parameters set for each CTS-FP.

If the CTS-MS reports in each CTS measurement results a RXQUAL_0 and a RXLEV greater or equal to 31, for a period of 30 seconds, the CTS-FP RF output power shall be at the end of this period the lowest nominal output power specified in 3GPP TS 45.056.

Under static interference free conditions, if the CTS-MS signal level received by the CTS-FP is greater or equal to -85 dBm for a period of 30 seconds, the CTS-FP shall command the CTS-MS to reduce its RF output power, so that the CTS-MS RF output power is at the end of this period the lowest nominal output power specified in 3GPP TS 45.005.

11.3.7 Timing

Upon receipt of a command from an SACCH to change its power level, the CTS-MS shall change to the new level at a rate of one nominal 2 dB power control step every 60 ms (13 TDMA frames), i.e. a range change of 15 steps should take about 900 ms. The change shall begin at the first TDMA frame belonging to the next reporting period (as specified in subclause 11.5.4). The CTS-MS shall change the power one nominal 2 dB step at a time, at a rate of one step every 60 ms following the initial change, irrespective of whether actual transmission takes place or not.

In case of intra-cell handover, the commanded power control level shall be applied on the new timeslot immediately.

11.4 Radio link failure

11.4.1 Criterion

The criterion for determining Radio Link Failure in the CTS-MS shall be based on the success rate of decoding messages on the downlink SACCH.

11.4.2 CTS-MS procedure

The aim of determining radio link failure in the CTS-MS is to ensure that calls with unacceptable voice/data quality, which cannot be improved either by RF power control or intra-cell handover, are either re-established or released in a defined manner.

The radio link failure criterion is based on the radio link counter S_CTS. If the CTS-MS is unable to decode a SACCH message (BFI = 1), S_CTS is decreased by 1. In the case of a successful reception of a SACCH message (BFI = 0) S_CTS is increased by 2. In any case S_CTS shall not exceed the value of CTS_RADIO_LINK_TIMEOUT. If S_CTS reaches 0 a CTS radio link failure shall be declared. The action to be taken is specified in 3GPP TS 44.056. The CTS_RADIO_LINK_TIMEOUT parameter is transmitted by the CTS-FP to the CTS-MS during the attachment procedure (see 3GPP TS 44.056). For the attachment or enrolment procedure, the CTS_RADIO_LINK_TIMEOUT shall be set to 64.

The CTS-MS shall continue transmitting as normal on the uplink until S_CTS reaches 0.

The algorithm shall start after the assignment of a dedicated channel and S_CTS shall be initialized to CTS_RADIO_LINK_TIMEOUT.

The detailed operation shall be as follows:

- the radio link time-out algorithm shall be stopped at the reception of a CTS intra-cell handover command;
- (re-)initialization and start of the algorithm shall be done whenever the CTS-MS switches to a new timeslot, at the latest when the main signalling link (see 3GPP TS 44.056) has been established;
- the CTS_RADIO_LINK_TIMEOUT value used at (re-)initialization shall be that used on the previous timeslot (in the CTS immediate assignment case the value stored by the CTS-MS during the attachment procedure), or the value received on SACCH if the CTS-MS has received a CTS_RADIO_LINK_TIMEOUT value on the new channel before the initialization;
- if the first CTS_RADIO_LINK_TIMEOUT value on the SACCH is received on the new channel after the initialization, the counter shall be re-initialized with the new value.

11.4.3 CTS-FP procedure

The criteria for determining radio link failure in the CTS-FP should be based upon either the error rate on the uplink SACCH or on RXLEV/RXQUAL measurements reported by the CTS-MS.

11.5 Radio link measurements

Radio link measurements are used in the intra-cell handover and RF power control processes.

The measurements are made over each SACCH multiframe, which is 104 TDMA frames (480 ms) for a TCH.

11.5.1 Signal strength

11.5.1.1 General

The received signal level may be employed as a criterion in the RF power control and intra-cell handover processes.

11.5.1.2 Physical parameter

As specified in subclause 8.1.2, measured by the CTS-MS and CTS-FP.

11.5.1.3 Statistical parameters

For each channel, the measured parameters (RXLEV) shall be the average of the received signal level measurement samples in dBm taken on that channel within the reporting period of length one SACCH multiframe defined in 11.5.4. In averaging, measurements made during previous reporting periods shall always be discarded.

When assigned a TCH, the CTS-MS shall make a received signal level measurement on all bursts of the associated physical channel (see 3GPP TS 45.002), including those of the SACCH.

For any TCH assigned to a CTS-MS, the CTS-FP shall make a received signal level measurement on all bursts of the associated physical channel including those of the SACCH.

11.5.1.4 Range of parameter

As specified subclause in subclause 8.1.4.

11.5.2 Signal quality

11.5.2.1 General

The received signal quality shall be employed as a criterion in the RF power control and intra-cell handover processes.

11.5.2.2 Physical parameter

As specified in subclause 8.2.2, measured by the CTS-MS and CTS-FP.

11.5.2.3 Statistical parameters

For each channel, the measured parameters (RXQUAL) shall be the received signal quality, averaged on that channel over the reporting period of length one SACCH multiframe defined in subclause 11.5.4. In averaging, measurements made during previous reporting periods shall always be discarded.

11.5.2.4 Range of parameter

As specified in subclause 8.2.4.

11.5.3 Aspects of discontinuous transmission (DTX)

The use of DTX is mandatory for the CTS-MS and the CTS-FP on a TCH. Not all TDMA frames may be transmitted, however, the subset specified in subclause 8.3 shall always be transmitted, and hence can be employed to assess quality and signal level during DTX.

11.5.4 Measurement reporting for the CTS-MS on a TCH

For a TCH, the reporting period of length 104 TDMA frames (480 ms) is defined in terms of TDMA frame numbers (FN) as follows:

Timeslot number (TN)	TDMA frame number (FN) modulo 104	
TCH/F	Reporting period	SACCH Message block
0 and 1	0 to 103	12, 38, 64, 90
2 and 3	26 to 25	38, 64, 90, 12
4 and 5	52 to 51	64, 90, 12, 38
6 and 7	78 to 77	90, 12, 38, 64

When on a TCH, the CTS-MS shall assess during the reporting period and transmit to the CTS-FP in the next SACCH message block the following:

- CTS_RXLEV_FULL_SERVING_CELL and CTS_RXQUAL_FULL_SERVING_CELL :
RXLEV_FULL and RXQUAL_FULL for the full set of TCH and SACCH TDMA frames. The full set of TDMA frames is 100 (i.e. 104 - 4 idle) frames for a full rate TCH;
- CTS_RXLEV_SUB_SERVING_CELL and CTS_RXQUAL_SUB_SERVING_CELL:
RXLEV_SUB and RXQUAL_SUB for the subset of 4 SACCH frames and the SID TDMA frames/L2 fill frames defined in 8.3. If no FACCH frames have been received at the corresponding frame positions, the RXQUAL_SUB report shall include measurements on the 4 SACCH frames only. The performance requirements of subclause 8.2.4 do not apply in this case for RXQUAL_SUB.

If the next SACCH message block is used for a different Layer 3 message, the averaged data which would otherwise be sent in that block is discarded and a new average started for the current block. i.e., any SACCH message will report the average data for the previous reporting period only.

The CTS-MS shall also transmit a bit (CTS_DTX_USED) in the next SACCH message block, which indicates whether or not it has employed DTX during the reporting period. This bit shall be set even if just one burst in a TDMA frame in the reporting period was not transmitted due to DTX.

NOTE: A speech frame subject to DTX may cross the "border" between two reporting periods, in which case both of the associated SACCH message blocks will have the CTS_DTX_USED flag set.

11.6 Control of CTS-FP service range

In order to restrict the CTS-FP service range, the CTS-FP shall monitor the delay of the signal sent by from the CTS-MS. For each CTS-MS the CTS-FP has allocated a TCH, a range measurement of the CTS-MS shall be computed by the CTS-FP every five reporting period by averaging over five reporting periods the assessed delay (as specified in 3GPP TS 45.010) for each received TCH burst of the subset always to be transmitted, specified in subclause 8.3, and for each received SACCH burst.

The TCH shall be released by the CTS-FP if two consecutive range measurements are greater than 1 bit period.

11.7 Control parameters

The parameters employed to control the radio link are shown in table 4, 5 and 6.

Table 4: Radio subsystem link control general parameters

Parameter name	Description	Range	Bits
CTS_FP_MAX_TXPWR	The maximum authorized output power control level the CTS-FP shall use (downlink)	0-31	5
CTS_MS_MAX_TXPWR	The maximum authorized output power control level a CTS-MS shall use with this CTS cell (uplink)	0-31	5
CTS_RXLEV_ACCESS_MIN	Minimum received level at the CTS-MS required for access to the system : coded as a RXLEV value (see subclause 8.1.4)	0-63	6
CTS_CELL_RESELECT_OFFSET	Applies an offset to the C2_CTS criterion : 0-63 dB in 63 steps of 1 dB	0-63	6
CTS_RADIO_LINK_TIMEOUT	The maximum value of the radio link counter : 4-64 SACCH blocks, in 15 steps of 4 SACCH blocks	0-15	4
CTSPCH_DECOD	Number of non-decoded paging messages before declaring a downlink paging failure	1-255	8

Table 5: AFA monitoring, BCCH detection and OFO measurement control parameters - dedicated connection

Parameter name	Description	Range	Bits	Message
AMFL (1-n)	AFA monitoring frequency list : contains n carriers represented by their ARFCN	0-1023	10	AFA monitoring order
NAMC	Number of AFA monitoring cycles	0-1023	10	AFA monitoring order
INTER_LEV (1-n)	Received interference level per carrier of the AMFL : coded as a RXLEV value (see subclause 8.1.4)	0-63	6	AFA monitoring report
NAMC_REAL	Minimum of the numbers of performed AFA monitoring cycles	0-1023	10	AFA monitoring report
BDFL (1-m)	BCCH detection frequency list : contains m carriers represented by their ARFCN	0-1023	10	BCCH detection order
BCCH_DETECT (1-m)	BCCH detection status : 00 : detected 01 : not detected 11 : not attempted	-	2	BCCH detection report
OMBL (1-k)	OFO measurement BCCH list : contains k BCCH carriers represented by their ARFCN	0-1023	10	OFO measurement order
OFO_MEAS (1-k)	OFO measurements list : 0.05 - 6.4 ppm in 127 steps of 0.05 ppm	0-127	7	OFO measurement report
OFO_STATUS (1-k)	OFO measurement status : 00 : measurement OK 01 : measurement failed 11 : measurement not attempted	-	2	OFO measurement report

Table 6: Intra-cell handover and power control parameters - SACCH

Parameter name	Description	Range	Bits	Message
CTS_MS_TXPWR_REQUEST (ordered MS power level)	The power level to be used by a CTS-MS	0-31	5	L1 header downlink
CTS_MS_TXPWR_CONF. (actual CTS-MS power level)	Indication of the power level in use by the CTS-MS.	0-31	5	L1 header uplink
CTS_POWER_LEVEL	The power level to be used by a CTS-MS on the indicated channel	0-31	5	CTS HO/assignment command
CTS_RXLEV_FULL_SERVING_CELL	The RXLEV in the current serving CTS cell accessed over all TDMA frames	0-63	6	CTS Measurement results
CTS_RXLEV_SUB_SERVING_CELL	The RXLEV in the current serving CTS cell accessed over a subset of TDMA frames	0-63	6	CTS Measurement results
CTS_RXQUAL_FULL_SERVING_CELL	The RXQUAL in the current serving CTS cell, assessed over all TDMA frames.	0-7	3	CTS Measurement results
CTS_RXQUAL_SUB_SERVING_CELL	The RXQUAL in the current serving CTS cell, assessed over subset of TDMA frames.	0-7	3	CTS Measurement results
CTS_DTX_USED	Indicates whether or not the CTS-MS used DTX during the previous measurement period.	-	1	CTS Measurement results

NOTE 1: RXLEV and RXQUAL fields are coded as described in subclause 11.6.
NOTE 2: For the details of the CTS Measurement Result message see 3GPP TS 44.056.

12 COMPACT Mode Tasks

12.1 Introduction

COMPACT is a radio interface mode for inter cell synchronized systems. The mapping of control channels for up to four cells is done on the same carrier and control channel separation is achieved by transmitting control in different cells on different timeslots. The mapping of the control channels is specified in 3GPP TS 45.002.

The COMPACT Mode Tasks defined in this clause applies for COMPACT capable MSs in cells employing a CPBCCH carrier as defined in 3GPP TS 45.002. The COMPACT Mode Tasks also applies for MSs in any cell, where at least one CPBCCH is defined in a BA list.

Note: A mobile stations designed prior to release 99 will not find CPBCCH carriers when it is looking for a BCCH carrier due to to the different structure of synchronization and frequency bursts.

12.2 Network Pre-requisites

12.2.1 CPBCCH carriers

The CPBCCH carrier shall be transmitted with constant RF output power on at least 4 radio blocks per multiframe on the serving time group (see 3GPP TS 45.002).

12.3 COMPACT Idle Mode Tasks

12.3.1 Introduction

Whilst in idle mode, a COMPACT capable MS shall implement cell selection and cell reselection procedures as described in 3GPP TS 43.022. These procedures make use of measurements and sub-procedures described in this clause.

The procedures ensure that the MS is camped on a cell from which it can reliably decode downlink data and with which it has a high probability of communications on the uplink. Once the MS is camped on a cell, access to the network is allowed.

The MS shall not use the discontinuous reception (DRX) mode of operation (i.e., powering itself down when it is not expecting paging messages from the network) while performing cell selection algorithms defined in 3GPP TS 43.022. However, use of powering down is permitted at all other times in idle mode.

12.3.2 Measurements for COMPACT Cell Selection

An MS shall in the COMPACT Cell selection procedure search for CPBCCCH carriers. The MS shall search all RF channels in the system within its band of operation, take readings of received RF signal level of each RF channel, and calculate the RLA_P for each. Each reading of received RF signal level shall be performed in such a way that it corresponds to the RF level at occurrences when the potential CPBCCCH carrier is transmitting CPBCH, CSCH, CFCCCH or CPBCCCH blocks. Since the CPBCCCH carrier is discontinuous, a single random measurement will not suffice. A single reading may instead consist of taking the maximum value out of multiple measurements. The succeeding averaging is based on at least five such measurement readings per RF carrier, where the readings are at least 1 s apart. This procedure is referred to as a CPBCCCH scan.

NOTE: It is allowed to only take readings of RF signal level of CPBCCCH carriers if identified.

CPBCCCH carriers may be identified, for example, by searching for frequency correction bursts and then synchronizing to and reading the synchronization bursts at the prescribed offset from the PFCCH bursts (see 3GPP TS 45.002). On finding a CPBCCCH carrier, the MS shall attempt to read the CPBCCCH data, taking into account that the actual timeslot allocation of the CPBCCCH will change from multiframe to multiframe.

The maximum time allowed for synchronization to a CPBCCCH carrier is 2.5 seconds. The maximum time allowed to read each system information message, when being synchronized to the CPBCCCH, is the time it takes to complete a broadcast cycle of that message.

12.3.3 Measurements for COMPACT Stored List Cell Selection

The MS may include storage of CPBCCCH carrier information when switched off as detailed in 3GPP TS 43.022. The CPBCCCH list may include CPBCCCH carriers from more than one band in a multi band operation PLMN. A MS may also store CPBCCCH carriers for more than one PLMN which it has selected previously (e.g. at national borders or when more than one PLMN serves a country), in which case the CPBCCCH carrier lists must be kept quite separate. The stored BCCCH carrier information used by the MS may be derived by a variety of different methods. As a minimum, the MS shall store the last used HPLMN CPBCCCH carriers. A memory shall host at least the 24 last CPBCCCH carriers from the HPLMN that the MS has camped on.

For a stored CPBCCCH carrier list of the selected PLMN an MS shall perform the same measurements as in subclause 12.3.2 except that only the CPBCCCH carriers in the list need to be measured.

NOTE: If the selected PLMN is equal to one of the equivalent PLMNs, then stored list cell selection applies to all equivalent PLMNs.

If stored list cell selection is not successful, then as defined in 3GPP TS 43.022, normal cell selection shall take place. Since information concerning a number of channels is already known to the MS, it may assign high priority to measurements on the strongest carriers from which it has not previously made attempts to obtain CPBCCCH information, and omit repeated measurements on the known ones.

12.3.4 Criteria for COMPACT Cell Selection

The path loss criterion parameter $C1$ used for cell selection and reselection when in a COMPACT cell is defined by:

$$C1 = (A - \text{Max}(B, 0))$$

where

$$\begin{aligned} A &= RLA_P - GPRS_RXLEV_ACCESS_MIN \\ B &= GPRS_MS_TXPWR_MAX_CCH - P \end{aligned}$$

GPRS_RXLEV_ACCESS_MIN= Minimum received signal level at the MS required for access to the system.

GPRS_MS_TXPWR_MAX_CCH= Maximum TX power level an MS may use when accessing the system until otherwise commanded.

P= Maximum RF output power of the MS.

All values are expressed in dBm.

The path loss criterion (3GPP TS 43.022) is satisfied if $C1 > 0$.

12.3.5 Downlink Signalling Failure

As defined for GPRS in subclause 6.5.

12.4 COMPACT Cell Reselection

In GPRS Standby and Ready states (*A/Gb mode*) or RRC-Idle or RRC-Connected mode (*Iu mode*), cell reselection is performed by the MS. The cell reselection procedures defined in this subclause apply when an MS is attached in a cell with a CPBCCCH carrier or monitors a cell with a CPBCCCH (or both). Otherwise, the MS shall perform cell reselection according to subclause 10.1, or if PBCCH does not exist according to subclause 6.6.

The cells to be monitored for cell re-selection, referred to as neighbour cells, are defined in the BA(GPRS) list, which is broadcast on PBCCH or CPBCCCH. If PBCCH or CPBCCCH does not exist, BA(GPRS) is equal to BA(BCCH).

12.4.1 Monitoring the received signal level and CPBCCCH data

The MS shall measure the received RF signal level on the CPBCCCH or BCCH carriers of the serving cell and the surrounding cells as indicated in the BA(GPRS) list and optionally the NC_FREQUENCY_LIST, and calculate the received level average (RLA_P) for each carrier.

In addition the MS shall verify the BSIC of the neighbour cells. Only cells with allowed BSIC shall be considered for re-selection. The allowed BSIC is either a valid BSIC or, for cells in BA(BCCH) where no BSIC is broadcast, a BSIC with allowed NCC part, (see subclause 7.2). A valid BSIC is a BSIC broadcast for that carrier in the BA(GPRS) list.

12.4.1.1 Packet idle mode or MAC-Idle state

Whilst in packet idle mode or MAC-Idle state an MS shall continuously monitor all BCCH and CPBCCCH carriers as indicated by the BA(GPRS) list in the system information of the serving cell. Note that both BCCH and CPBCCCH carriers may be defined in the BA(GPRS) list. At least one received signal level measurement sample on each neighbour cell shall be taken for each paging block monitored by the MS according to its current DRX mode and its paging group. As the minimum MS shall take one measurement for each BCCH or CPBCCCH carrier for every 4 second. As the maximum, the MS is however not required to take more than 1 samples per second for each neighbour cell. For CPBCCCH carriers, only the TDMA frames where common control or broadcast blocks are transmitted are used for monitoring signal levels, see subclause 12.3.2.

RLA_P shall be a running average determined using samples collected over a period of 5 s to $\text{Max}\{5s, \text{five consecutive paging blocks of that MS}\}$, and shall be maintained for each BCCH or CPBCCCH carrier. The same number of measurement samples shall be taken for all neighbour cells, and the samples allocated to each carrier shall as far as possible be uniformly distributed over the evaluation period. At least 5 received signal level measurement samples are required for a valid RLA_P value.

The list of the 6 strongest non-serving cells shall be updated at a rate of at least once per running average period.

The MS shall attempt to check the BSIC for each of the 6 strongest non-serving cells at least every 14 consecutive paging blocks of that MS or 10 seconds, whichever is greater. If a change of BSIC is detected then the cell shall be treated as a new cell.

When requested by the user, the MS shall determine which PLMNs are available as described in subclause 6.6.1. However, for MSs without DRX or with short DRX period (see 3GPP TS 45.002), considerable interruptions to the monitoring of PPCH can not be avoided.

12.4.1.2 Packet transfer mode or MAC-Shared state

Whilst in packet transfer mode or MAC-Shared state a MS shall continuously monitor all BCCH or CPBCCCH carriers as indicated by the BA(GPRS) list and the broadcast carrier of the serving cell. In every TDMA frame possible, a received signal level measurement sample shall be taken on at least one of the BCCH carriers or CPBCCCH time groups, one after another, as evenly distributed as possible among the neighbours. As an exception for CPBCCCH carriers on multislot allocations the MS shall take at least 4 received signal level measurement samples for CPBCCCH carriers from two different time groups (2 samples/time group) in every 52 multiframe, as evenly distributed as possible among the neighbours. For CPBCCCH carriers, only the TDMA frames where common control or broadcast blocks are transmitted are used for monitoring signal levels, see subclause 12.3.2.

RLA_P shall be a running average determined using samples collected over a period of 5 s, and shall be maintained for each BCCH and CPBCCCH carrier. The samples taken on each carrier shall as far as possible be uniformly distributed over the evaluation period. At least 5 received signal level measurement samples are required for a valid RLA_P value.

The MS shall attempt to check the BSIC for as many non-serving cells as possible and as often as possible, and at least every 10 seconds. The MS shall use TDMA frame 51 of the PDCH multiframe for checking BSICs of CPBCCCH carriers and TDMA frame 25 or 51 for checking BSIC of BCCH carriers. These frames are termed search frames. A list containing BSIC and timing information for these strongest carriers at the accuracy required for accessing a cell (see 3GPP TS 45.010) including the absolute times derived from the parameters T1, T2 T3 or R1, R2, TG shall be kept by the MS. This information may be used to schedule the decoding of BSIC and shall be used when re-selecting a new cell in order to keep the switching time at a minimum. When a BCCH or CPBCCCH carrier is found to be no longer among the reported, BSIC and timing information shall be retained for 10 seconds. (This is in case a cell re-selection command to this cell is received just after the MS has stopped reporting that cell, see subclause 10.1.4.2).

If, after averaging measurement results over 4 PDCH multiframes (1 sec), the MS detects one or more BCCH or CPBCCCH carrier, among the 6 strongest, whose BSICs are not currently being assessed, then the MS shall as a matter of priority decode their BSICs.

The MS shall be able to send the first packet random access (PRACH) at the latest 5+x seconds after a new strongest cell (which is part of the BA(GPRS)) has been activated under the following network conditions: Initial serving cell at RXLEV= -70 dBm, with 6 neighbours at RXLEV= -75 dBm. Then the new CPBCCCH or BCCH carrier is switched on at RXLEV= -60 dBm. x is the longest time it may take to receive the necessary system information on CPBCCCH or BCCH in the new cell.

NOTE: Because of test equipment limitations it is acceptable to activate the new carrier to replace one of the 6 neighbours.

In the case of a multiband MS, the MS shall attempt to decode the BSIC, if any BCCH or CPBCCCH carrier with unknown BSIC is detected among the number of strongest CPBCCCH carriers in each band as indicated by the Multiband Reporting parameter (see subclause 8.4.3).

Thus an MS shall, for a period of up to 5 seconds, devote all search frames to attempting to decode these BSICs. If this fails then the MS shall return to confirming existing BSICs. Having re-confirmed existing BSICs, if there are still BCCH or CPBCCCH carriers, among the six strongest, with unknown BSICs, then the decoding of these shall again be given priority for a further period of up to 5 seconds.

If either no BSIC can be decoded on a surrounding cells, or the BSIC is not allowed, then the received signal level measurements on that channel shall be discarded and the MS shall continue to monitor that channel.

If a change of BSIC is detected on a carrier, then any existing received signal level measurement shall be discarded and the carrier shall be treated as a new carrier.

If the BSIC cannot be decoded at the next available opportunities re-attempts shall be made to decode this BSIC. If the BSIC is not decoded for more than three successive attempts it will be considered lost and any existing received signal level measurement shall be discarded and the MS shall continue to monitor that carrier.

12.4.2 COMPACT cell reselection criteria

The COMPACT GPRS mode cell reselection criteria follows the GPRS cell reselection criteria described in subclause 10.1.2.

12.4.3 COMPACT cell reselection algorithm

The cell reselection algorithm for COMPACT follows the procedures described for GPRS in subclause 10.1.3.

12.4.4 Network controlled Cell reselection

The network controlled cell reselection for COMPACT follows the procedures described for GPRS in subclause 10.1.4.

12.4.5 COMPACT cell reselection measurement opportunities

COMPACT utilizes a timeslot mapping of control channel in a rotating fashion as described in 45.002. With this timeslot rotation, a mobile can make COMPACT neighbour cell measurements of all four time-groups. The timeslot that an MS can use for measurements is dependent on the timeslot number used for traffic. During one 52-multiframe, the MS is able to measure one time-group on up to 4 frequencies once per control block. During 1 s time period (4 multiframe), the MS is able to measure all 4 time-groups .

The CPBCCCH carrier shall be transmitted with constant RF output power as defined in subclause 12.2.1, during a minimum number of control blocks. The actual number of control blocks transmitted with constant RF output power in a neighbour cell is indicated in the neighbour cell parameter GUAR_CONST_PWR_BLKS, broadcast in with the neighbour cell description for an EGPRS neighbour cell.

Annex A (informative): Definition of a basic GSM or DCS 1 800 handover and RF power control algorithm

A.1 Scope

This annex specifies a basic overall handover algorithm and RF power control process that may be implemented in the GSM or DCS 1 800 system.

The specification includes a set of algorithms that are sufficient to allow the successful implementation of an initial GSM or DCS 1 800 system, and from which more complex algorithms may be developed.

The basic solution is not mandatory for network operators.

A.2 Functional requirement

The present algorithm is based on the following assumptions:

- single cell BSS;
- the necessity to make a handover according to radio criteria is recognized in the BSS. It can lead to either an (internal) intracell handover or an intercell handover;
- evaluation of a preferred list of target cells is performed in the BSS;
- cell allocation is done in the MSC;
- intracell handover for radio criteria (interference problems) may be performed directly by the BSS;
- the necessity to make a handover because of traffic reason (network directed handover) is recognized by the MSC and it is performed by sending a "handover candidate enquiry message" to BSS;
- the RF power control algorithm shall be implemented in order to optimize the RF power output from the MS (and BSS if power control is implemented) ensuring at the same time that the signal level received at the BSS (MS) is sufficient to keep adequate speech/data quality;
- all parameters controlling the handover and power control processes shall be administered on a cell by cell basis by means of O&M. The overall handover and power control process is split into the following stages:
 - i) BSS pre-processing and threshold comparisons;
 - ii) BSS decision algorithm;
 - iii) MSC cell allocation algorithm.

A BSS decision algorithm is specified such that the BSS can fulfil the mandatory requirement of being able to produce a preferred list of target cells for handover.

It should be noted that since measurement results can also be sent to the MSC in the "handover required" message, the handover decision algorithm may be implemented in either the MSC or the BSS.

A.3 BSS pre-processing and threshold comparisons

For the purpose of handover and RF power control processing, the BSS shall store the parameters and thresholds shown in table A.1. These shall be administered on a cell by cell basis and downloaded to the BSS by O&M procedures.

The parameters and thresholds related to the downlink power control process are stored and used only if BSS RF power control is implemented.

The following measurements shall be continuously processed in the BSS:

- i) Measurements reported by MS on SACCH:
 - Down link RXLEV;
 - Down link RXQUAL;
 - Down link surrounding cell RXLEV (RXLEV_NCELL (n) on BCCH as indicated in the BCCH Allocation).
- ii) Measurements performed in BTS:
 - Uplink RXLEV;
 - Uplink RXQUAL;
 - MS-BTS distance;
 - Interference level in unassigned time slots.

Every SACCH multiframe (480 ms) a new processed value for each of the measurements shall be calculated.

A.3.1 Measurement averaging process

The BSS shall be capable of pre-processing the measurements by any of the following processes:

- Unweighted average;
- Weighted average, with the weightings determined by O&M;
- Modified median calculation, with exceptionally high and low values (outliers) removed before the median calculation.

The timing of the processing shall be controlled by parameters, set by O&M, as follows:

- a) RXLEV_XX (XX = DL or UL):

For every connection and for both links at least the last 32 samples shall be stored (a sample is the value evaluated by the MS and BSS during a period of 480 ms). Every 480 ms, with these samples, the BSS shall evaluate the averaged value of the received power as defined by the parameters Hreqave and Hreqt, applicable to RXLEV.

- b) RXLEV_DL on BCCH carriers (RXLEV_NCELL (n)):

For every connection and for each of up to 16 defined cells the BSS shall store the values related to the last 32 samples. The BSS shall average these samples as defined by the parameters Hreqave, Hreqt, applicable to RXLEV.

- c) RXQUAL_XX (XX = DL or UL):

For every connection and for both links at least 32 samples shall be stored (a sample is the value calculated by the MS and BSS during period of 480 ms). Every 480 ms, with these samples, the BSS shall evaluate the received signal quality as defined by the parameters Hreqave and Hreqt, applicable to RXQUAL.

d) MS-BTS distance:

For every connection the BSS shall average the adaptive frame alignment value as defined by the parameters Hreqave and Hreqt, to derive an estimate of the MS-BTS distance.

e) Interference level in unassigned time slots:

The BSS shall average the interference level in unassigned timeslots as defined by the Intave parameter. The averaged results shall be mapped into five interference categories (see 3GPP TS 48.008) whose limit O-X5 are adjusted by O&M.

f) Power Budget:

This assessment process may be employed by the network as a criterion in the handover process, by setting a flag in the BSS by O&M command. If the process is employed, every 480 ms, for every connection and for each of allowable 32 adjacent cells, the BSS shall evaluate the following expression:

$$PBGT(n) = (\text{Min}(MS_TXPWR_MAX,P) - RXLEV_DL - PWR_C_D) - (\text{Min}(MS_TXPWR_MAX(n),P) - RXLEV_NCELL(n))$$

Where the values of RXLEV_NCELL(n) and RXLEV_DL are obtained with the averaging processes defined above. PWR_C_D is the difference between the maximum downlink RF power permitted in the cell and the actual downlink power due to the BSS power control. MS_TXPWR_MAX is the maximum RF TX power an MS is permitted to use on a traffic channel in the serving cell. MS_TXPWR_MAX (n) is the maximum RF TX power an MS is permitted to use on a traffic channel in adjacent cell n. P is the maximum TX power capability of the MS.

g) Hreqave and Hreqt:

The values of Hreqt and Hreqave are defined by O&M for each cell for the averaging of reported measurements. The values of Hreqave and Hreqt can be different for each of the parameters being averaged.

Hreqave:

defines the period over which an average is produced, in terms of the number of SACCH blocks containing measurement results, i.e. the number of measurements contributing to each averaged measurement.

Hreqt:

is the number of averaged results that are maintained.

The BSS shall support values of Hreqave and Hreqt such that

$$0 < Hreqav < 32$$

$$\text{and } 0 < Hreqt < 32$$

$$\text{where } Hreqave * Hreqt < 32$$

A.3.2 Threshold comparison process

A.3.2.1 RF power control process

Every SACCH multiframe, the BSS shall compare each of the processed measurements with the relevant thresholds. The threshold comparison processes and the actions to be taken are as follows:

a) Comparison of RXLEV_XX with L_RXLEV_XX_P (XX = DL or UL)

The algorithm shall be applied to the averaged RXLEV values (defined in subclause A.3.1:a). The comparison process shall be defined by the parameters P1 and N1 as follows:

- Increase XX_TXPWR if at least P1 averages out of N1 averages are lower than L_RXLEV_XX_P. (e.g. P1 = 10 and N1 = 12)

b) Comparison of RXLEV_XX with U_RXLEV_XX_P (XX = DL or UL)

The algorithm shall be applied to the averaged RXLEV values (defined in subclause A.3.1:a). The comparison process shall be defined by the parameters P2 and N2 as follows:

- Decrease XX_TXPWR if at least P2 averages out of N2 averages are greater than U_RXLEV_XX_P. (e.g. P2 = 19 and N2 = 20)

c) Comparison of RXQUAL_XX with L_RXQUAL_XX_P (XX = DL or UL)

The algorithm shall be applied to the averaged RXQUAL values (defined in subclause A.3.1:c) The comparison process shall be defined by the parameters P3 and N3 as follows:

- Increase XX_TXPWR if at least P3 averaged values out of N3 averaged values are greater (worse quality) than L_RXQUAL_XX_P. (e.g. P3 = 5 and N3 = 7)

d) Comparison of RXQUAL_XX with U_RXQUAL_XX_P (XX = DL or UL) The algorithm shall be applied to the averaged RXQUAL values (defined in subclause A.3.1:c) The comparison process shall be defined by the parameters P4 and N4 as follows:

- Decrease XX_TXPWR if at least P4 averaged values out of N4 averaged values are lower (better quality) than U_RXQUAL_XX_P. (e.g. P4 = 15, N4 = 18)

A.3.2.2 Handover Process

Every SACCH multiframe, the BSS shall compare each of the processed measurements with the relevant thresholds. The threshold comparison processes and the actions to be taken are as follows:

a) Comparison of RXLEV_XX with L_RXLEV_XX_H (XX = DL or UL)

The algorithm shall be applied to the averaged RXLEV values (defined in subclause A.3.1:a). The comparison process shall be defined by the parameters P5 and N5 as follows:

- If at least P5 averaged values out of N5 averaged values are lower than L_RXLEV_XX_H a handover, cause XX_RXLEV, might be required. (e.g. P5 = 10 and N5 = 12).

b) Comparison of RXQUAL_XX with L_RXQUAL_XX_H (XX = DL or UL)

The algorithm shall be applied to the averaged RXQUAL values (defined in subclause A.3.1:c) The comparison process shall be defined by the parameters P6 and N6 as follows:

- If at least P6 averaged values out of N6 averaged values are greater (worse quality) than L_RXQUAL_XX_H a handover, cause XX_RXQUAL, might be required. (e.g. P6 = 5 and N6 = 7).

c) Comparison of RXLEV_XX with RXLEV_XX_IH (XX= DL or UL)

The algorithm shall be applied to the averaged RXLEV values (defined in subclause A.3.1:a). The comparison process shall be defined by the parameters P7 and N7 as follows:

- If at least P7 averaged values out of N7 averaged values are greater than RXLEV_XX_IH an internal handover might be required if RXQUAL_XX is also greater (worse quality) than L_RXQUAL_XX_H (e.g. P7 = 10 and N7 = 12).

d) Comparison of MS-BTS distance with the MAX_MS_RANGE

This comparison process may be employed by the network as a criterion in the handover process by setting a flag in the BSS by O&M. If the process is employed, the algorithm shall be applied to the averaged values defined in subclause A.3.1:d. The comparison process shall be defined by the parameters P8 and N8 as follows:

- If at least P8 averaged values out of N8 values are greater than MS_RANGE_MAX a handover, cause DISTANCE, might be required. (e.g. P8 = 8 and N8 = 10).

- e) Comparison of PBGT(n) with the HO_MARGIN(n)

If the process is employed, the action to be taken is as follows:

- If $PBGT(n) > 0$ and $PBGT(n) > HO_MARGIN(n)$ a handover, cause PBGT(n), might be required.

This comparison enables handover to be performed to ensure that the MS is always linked to the cell with the minimum path loss, even though the quality and signal level thresholds may not have been exceeded.

A.4 BSS decision algorithm

Recognizing the necessity to request a handover the BSS shall send a "handover required message" to the MSC containing the preferred list of target cells.

The "handover required message" shall be also generated in answer to a "handover candidate enquiry message" sent by the MSC.

The BSS decision algorithm shall be based on the following strategy:

$$RXLEV_NCELL(n) > RXLEV_MIN(n) + \text{Max}(O, P_a) \quad (\text{A.1})$$

where: $P_a = (MS_TXPWR_MAX(n) - P)$

$$(\text{Min}(MS_TXPWR_MAX, P) - RXLEV_DL - PWR_C_D) - (\text{Min}(MS_TXPWR_MAX(n), P) -$$

$$RXLEV_NCELL(n)) - HO_MARGIN(n) > 0 \quad (\text{A.2})$$

All these expressions shall be evaluated using the averaged values defined by the parameters Hreqt and Hreqave.

The BSS shall evaluate the equation (A.2) for each of the adjacent cells that satisfies the expression (A.1) and shall compile the list of the preferred adjacent cells ordinated depending on the value of equation (A.2) (i.e. in the first position is the cell for which the value is the maximum, in the second position is the cell with the second best value and so on).

If there are any adjacent cells for which the values of RXLEV_MIN(n), HO_MARGIN(n) and MS_TXPWR_MAX(n) are not known, i.e. the MS has reported values from an undefined adjacent cell, then the default parameters shall be used to evaluate equations 1 and 2, i.e. RXLEV_MIN_DEF, HO_MARGIN_DEF, MS_TXPWR_MAX_DEF. This enables handover to occur in situations where a call is set up in unexpected coverage area of a cell, without defined adjacent cells.

If there are several cells that satisfy the equation (A.2) with the same results, the first cell in the list will be that one with the best "positive trend". The trend shall be evaluated by the BSS using the last Hreqt averaged values of RXLEV_NCELL(n).

If the handover is considered imperative, that is one of the following events is verified as the cause:

- a) the power level (UL and/or DL) is below the thresholds despite power control (the MS or/and the BSS have reached the maximum allowed power);
- b) the quality of the link (UL and/or DL) is below the threshold while at the same time the RXLEV approximates the threshold;
- c) the distance between MS and BTS exceeds the MAX_MS_RANGE.

The list of the preferred cells shall be compiled including any candidates for which the result of the equation (A.2) is lower than 0. Also in this case the list shall be compiled in a decreasing order of priority.

A.4.1 Internal intracell handover according to radio criteria: (Interference problems)

The two conditions $RXQUAL_XX > L_RXQUAL_XX_H$ (bad quality) and $RXLEV_XX > RXLEV_XX_IH$, if verified at the same time, indicate a high probability of the presence of co-channel interference.

This situation can be solved by changing the channel within the cell with an intracell handover.

If internal intracell handover is supported by the BSS it shall be performed as described in 3GPP TS 48.008.

If the BSS does not support internal intracell handover, then the handover shall be initiated by sending a "handover required message" to the MSC in which the serving cell is indicated as first priority.

A.4.2 Internal handover according to other criteria

Apart from radio criteria there are other criteria that may require internal handover:

- O&M criteria;
- Resource management criteria.

In these cases, internal handover shall be triggered by the OMC or by the resource management of the BSS.

A.4.3 General considerations

Since the RF power control process and the handover process are closely linked, particular care shall be taken in order to avoid undesired interactions between them.

In particular, the following interactions should be avoided, where possible:

- a "power increase command" or a "handover for RXLEV or for RXQUAL" subsequent to a "power reduction command" (e.g. by checking that the averaged power level reduced by the Pow_Red_Step_Size plus the tolerances is greater than the L_RXLEV_XX_P or L_RXLEV_XX_H);
- a "power reduction command" subsequent to a "power increase command".

After an action of power control the set of samples related to the previous power level, in the corresponding link, shall not be used in the processing.

If, during the decision process, the condition for the "handover required message" is satisfied at the same time by different reasons. The "cause field" in the "handover required message" sent to the MSC, shall contain the reasons taking account of the following order of priority:

- RXQUAL;
- RXLEV;
- DISTANCE;
- PBGT.

A.5 Channel allocation

As described in 3GPP TS 48.008 the available channels shall be divided into five interference categories whose limits O-X5 are adjusted by O&M command.

For handover, the channel allocated should be from the category with the lowest interference level, since determination of the expected value of C/I is not possible by the new BSS.

A.6 Handover decision algorithm in the MSC

The MSC shall select the cell to which an MS is to be handed over by the following criteria:

- Handover for radio criteria shall be handled taking into account the following order of priority:
 - RXQUAL;
 - RXLEV;
 - DISTANCE;
 - PBGT.

e.g. if there are more handover bids to a cell than there are free traffic channels, then the bids with cause "RXQUAL" shall take highest priority.

- In order to avoid overload in the network, for every cell and with reference to each of 16 adjacent cells, it shall be possible to define (by O&M) for each adjacent cell one of at least 8 priority levels. These shall be considered together with the list of candidates and the interference levels in the choice of the new cell. For example, if there are two cells which meet the criteria for handover, then the cell with the highest priority shall be used. This enables umbrella cells, for instance, to be given a lower priority, and only handle calls when no other cell is available.
- Channel congestion on the best cell shall cause the choice of the second best cell, if available, and so on. If no cell is found and call queuing is employed in the MSC, then the MSC shall queue the request on the best cell for a period equal to H_INTERVAL (H_INTERVAL < T_Hand_RQD shall be set by O&M). This handover shall have priority over the queue handling new calls.

Table A.1: Parameters and thresholds stored for handover purposes

L_RXLEV_UL_P	RXLEV threshold on the uplink for power increase. Typical range - 103 to - 73 dBm.
U_RXLEV_UL_P	RXLEV threshold on the uplink for power reduction.
L_RXQUAL_UL_P	RXQUAL threshold on the uplink for power increase.
U_RXQUAL_UL_P	RXQUAL threshold on the uplink for power reduction.
L_RXLEV_DL_P	RXLEV threshold on the downlink for power increase. Typical range - 103 to - 73 dBm.
U_RXLEV_DL_P	RXLEV threshold on the downlink for power reduction.
L_RXQUAL_DL_P	RXQUAL threshold on the downlink for power increase.
U_RXQUAL_DL_P	RXQUAL threshold on the downlink for power reduction.
L_RXLEV_UL_H	RXLEV threshold on the uplink for handover process to commence. Typical range - 103 to - 73 dBm.
L_RXQUAL_UL_H	RXQUAL threshold on the uplink for handover process to commence.
L_RXLEV_DL_H	RXLEV threshold on the downlink for handover process to commence. Typical range - 103 to - 73 dBm.
L_RXQUAL_DL_H	RXQUAL threshold on the downlink for handover process to commence.
MS_RANGE_MAX	Threshold for the maximum permitted distance between MS and current BTS. Range (2, 35 Km); step size 1.0 Km.
RXLEV_UL_IH	RXLEV threshold on uplink for intracell (interference) handover. Typical range - 85 to - 40 dBm.
RXLEV_DL_IH	RXLEV threshold on downlink for intracell (interference) handover; typical range - 85 to - 40 dBm.
RXLEV_MIN(n)	Minimum RXLEV required for an MS to be allowed to handover to cell "n".
RXLEV_MIN_DEF	Default value of RXLEV_MIN, used to evaluate handover to undefined adjacent cells.
HO_MARGIN(n)	A parameter used in order to prevent repetitive handover between adjacent cells. It may be also used as a threshold in the power budget process. Range (0, 24 dB); step size 1 dB.
HO_MARGIN_DEF	Default value of HO_MARGIN, used to evaluate handover to undefined adjacent cells.
N_CELL list	List of allowable adjacent cells for handover. Range (0, 32).
MS_TXPWR_MAX	Maximum TX power a MS may use in the serving cell. Range (5, 39 dBm) for GSM and (0,36 dBm) for DCS 1 800; step size 2 dB.
MS_TXPWR_MAX(n)	Maximum TX power a MS may use in the adjacent cell "n". Range (5, 39 dBm) for GSM and (0,36 dBm) for DCS 1 800; step size 2 dB.
MS_TXPWR_MAX_DEF	Default value of MS_TXPWR_MAX, used to evaluate handover to undefined adjacent cells.
BS_TXPWR_MAX	Maximum TX power used by the BTS.
O.X5	Boundary limits of five interference bands for the unassigned time slots. Typical range -115 to -85 dBm. (See 3GPP TS 48.008).
Hreqave	RXLEV, RXQUAL and MS_BTS Distance averaging periods defined in terms of number of SACCH multiframes. Range (1, 31); step size 1.
Hreqt	The number of averaged results that can be sent in a "handover required message" from BSS to MSC. Range (1, 31); step size 1.
Intave	Interference averaging period defined in terms of the number of SACCH multiframes. Range (1, 31); step size 1.
N1..N8,P1..P8	The number of samples used in the threshold comparison processes. Range (1, 31); step size 1.
P_Con_INTERVAL	Minimum interval between changes in the RF power level. Range (0, 30 s) step size 0.96 s.
T_Hand_RQD	Minimum interval between handover required messages related to the same connection. Range (0, 30 s); step size 0.96 s.
Pow_Incr_Step_Size	Range 2, 4 or 6 dB.
Pow_Red_Step_Size	Range 2 or 4 dB.
Number of Ranges (NR)	Number of ranges in BA_RANGE indicating the number of ranges of ARFCNs containing BCCH carriers for use as stored BCCH information.
RANGEi_LOWER	Lowest ARFCN in the ith range of carriers containing BCCH carriers for use as stored BCCH information.
RANGEi_HIGHER	Highest ARFCN in the ith range of carriers containing BCCH carriers for use as stored BCCH information.

All thresholds shall be able to take any value within the range of the parameter to which they apply. Typical operating ranges are given for some thresholds.

Annex B (informative): Power Control Procedures

Power control is important for spectrum efficiency as well as for power consumption in a cellular system. For good spectrum efficiency quality based power control is required. Power control for a packet oriented connection is more complicated than for a circuit switched connection, since there is no continuous two-way connection.

The power control formula for the MS is specified in subclause 10.2.1 (formula 1):

$$P = \Gamma_0 - \Gamma_{CH} - \alpha (C + 48) \quad (\text{all power calculations in dB})$$

This is a flexible tool that can be used for different power control algorithms. (Note that the constants Γ_0 and 48 are included only for optimising the coding of Γ_{CH}). For the BTS, there is no need to specify any algorithm, but a similar formula can be used. The following are examples of possible algorithms for uplink power control:

- Open loop control.
With this method the output power is based on the received signal level assuming the same path loss in uplink and downlink. This is useful in the beginning of a packet transmission.
- Closed loop control.
With this method the output power is commanded by the network based on received signal level measurements made in the BTS in a similar way as for a circuit switched connection.
- Quality based control.
This method can be used in combination with any of the two methods above.

B.1 Open loop control

A pure open loop is achieved by setting $\alpha = 1$ and keeping Γ_{CH} constant. The output power will then be:

$$P = \Gamma_0 - \Gamma_{CH} - C - 48$$

The value Γ_{CH} can be calculated as follows to give a target value for the received signal, SS_b , at the BTS.

The received signal level at the MS:

$$SS_m = P_{BTS} - P_b - L$$

where P_{BTS} = BTS maximum output power
 P_b = BTS power reduction due to power control
 L = path loss

The C value (normalised received signal level):

$$C = SS_m + P_b = P_{BTS} - L$$

The MS output power: $P = \Gamma_0 - \Gamma_{CH} - C - 48 = \Gamma_0 - \Gamma_{CH} - P_{BTS} + L - 48$

The received signal level at the BTS:

$$SS_b = P - L = \Gamma_0 - \Gamma_{CH} - P_{BTS} - 48$$

The constant value of Γ_{CH} :

$$\Gamma_{CH} = \Gamma_0 - P_{BTS} - SS_b - 48$$

B.2 Closed loop control

A pure closed loop is achieved by setting $\alpha = 0$. The output power will than be:

$$P = \Gamma_0 - \Gamma_{CH}$$

In this case, Γ_{CH} is the actual power level (relative to Γ_0) commanded by network. It can be based on the received signal level measured at the BTS. Power control commands can be sent when required in order to achieve the target received signal level.

B.3 Quality based control.

In order to achieve the best performance the power control should be quality based. The algorithm must also consider the path loss for stability. The algorithm is not specified, it is the responsibility of the manufacturer and/or the operator.

An example of a quality based power control algorithm is:

$$P_{n+1} = P_{max} - \alpha ((C/I_n - C/I_{min}) - (P_n - P_{max})) = P_{ref} - \alpha (C/I_n - P_n)$$

where P is the output power from the MS.
 C/I is the received carrier to interference value at the BTS.
 P_{max} , C/I_{min} and P_{ref} are reference values.
 α is a weighting factor.
 n is the iteration index.

In the closed loop case, this formula determines Γ_{CH} :

$$\Gamma_{CH} = \Gamma_0 - P_{n+1}.$$

For the open loop case, we rewrite the formula. The carrier to interference can be written:

$$C/I = C_{BTS} - I_{BTS} = P - L - I_{BTS}$$

where C_{BTS} is the received signal level at the BTS.
 I_{BTS} is the received interference level at the BTS.

$$\text{thus } P_{n+1} = P_{ref} - \alpha (P_n - L_n - I_{BTS,n} - P_n) = P_{ref} + \alpha (L_n + I_{BTS,n})$$

As shown above, the path loss is:

$$L = P_{BTS} - C$$

The formula can therefore be written as (dropping the iteration index):

$$P = P_{ref} + \alpha (P_{BTS} - C + I_{BTS}) = \Gamma_0 - \Gamma_{CH} - \alpha (C - 48)$$

Thus, for the open loop case:

$$\Gamma_{CH} = \Gamma_0 - P_{ref} - \alpha (P_{BTS} + I_{BTS} - 48)$$

The interference level I_{BTS} is measured in the BTS. The parameter Γ_{CH} is estimated based on these measurements, considering the appropriate weighting factor α , and the known parameters P_{ref} and P_{BTS} . The Γ_{CH} values are transferred to the MS in the Power Control Parameters (see 3GPP TS 44.060).

B.4 BTS power control

The same algorithm as above can be used for downlink power control. The formula for quality based control in the MS

$$P_{n+1} = P_{ref} + \alpha (L_n + I_{BTS,n})$$

can be written for the BTS as:

$$P_{d_{n+1}} = P_{ref} + \alpha (L_n + \gamma_{CH,n})$$

where P_d is the BTS output power (equal to $P_{BTS} - P_b$).
 γ_{CH} is the received interference level at the MS.

Substituting the path loss and dropping the iteration index gives:

$$P_d = P_{ref} + \alpha (P_{BTS} - C + \gamma_{CH})$$

The received signal C and interference γ_{CH} is measured in the MS and transferred to the BTS, which can calculate the output power.

B.5 Example

Figure B.1 illustrates an example of the uplink power control function.

In packet idle mode or MAC-Idle state, the MS measures the C value on each monitored PPCH block. Meanwhile, the BSS measures the interference of the candidate PDCHs in order to have Γ_{CH} values ready for the first transfer period. This is transferred to the MS in the Packet Uplink Assignment.

In packet transfer mode or MAC-Shared state, the MS measures the C value on the BCCH carrier and updates its output power. The BSS updates the MS specific Γ_{CH} values and transfer them to the MS when needed, i.e. when the interference level has changed.

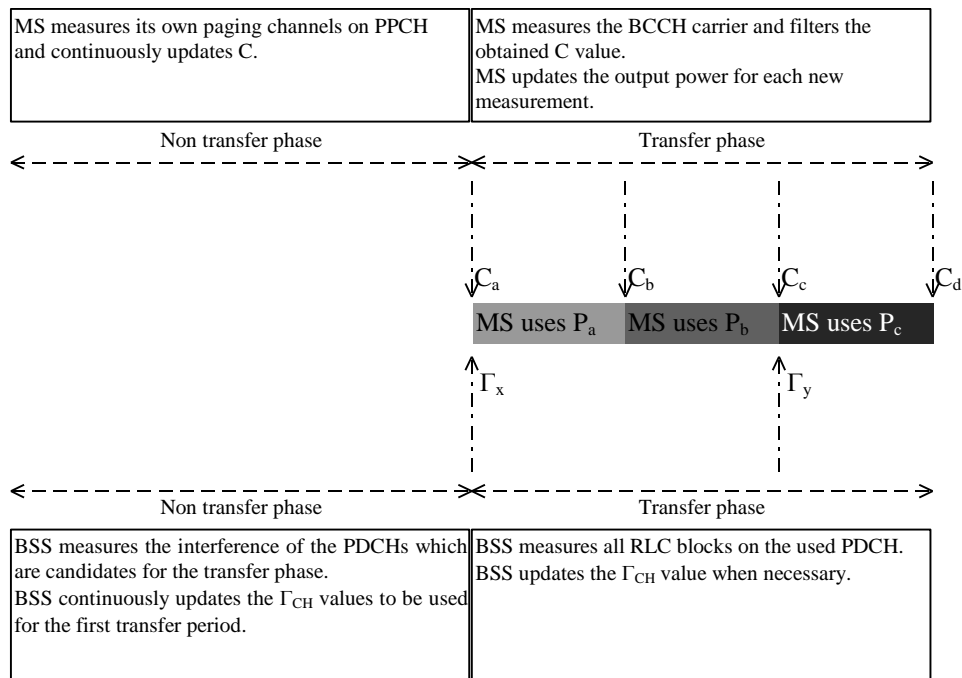

Figure B.1: Traffic example of uplink power control

Figure B.2 illustrates an example of the downlink power control function.

In packet idle mode or MAC-Idle state, the MS measures the C value on each monitored PPCH block.

In packet transfer mode or MAC-Shared state, the MS measures the C value on the BCCH carrier and the γ_{CH} values on all channels on the same carrier as the assigned PDCH. These values are transferred to the BTS in the Packet Downlink Ack/Nack messages. The BSS then updates the output power.

The BTS may use the maximum power for the first transfer period and set the polling for Ack/Nack as soon as possible to get the values measured in packet idle mode or MAC-Idle state.

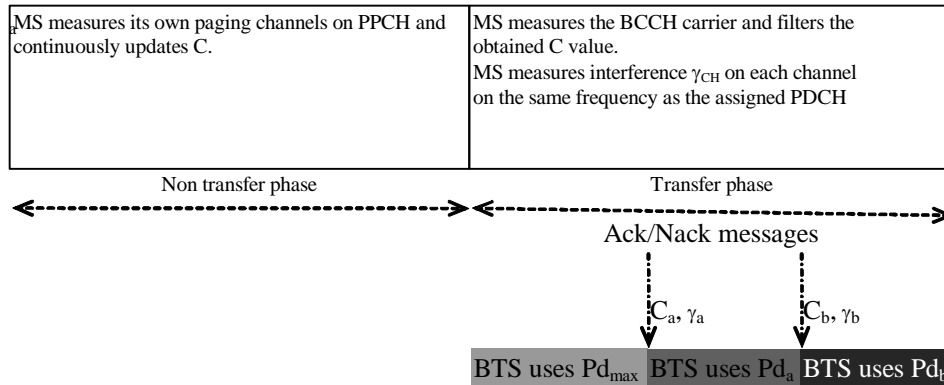

Figure B.2: Traffic example of downlink power control

B.6 Interworking between normal and fast power control for ECSD

Interworking between normal and fast power control in the ECSD mode is done so that the normal power control may be running even if fast power control is activated. This means that both the BSS and the MS shall, at all times when in dedicated ECSD mode, estimate the radio link quality plus send power level commands and link quality reports respectively based on the cycle of the reporting period of length 104 TDMA frames (as specified in subclause 8.4). When FPC is activated though, the power level commands sent via SACCH are ignored by the MS.

Through this, a switch back to normal power control can be done very easily since the MS always knows what power level to use immediately after a switch. Switching between normal and fast power control always takes place at the beginning of a reporting period.

The figure below illustrates the simultaneous operation of the two power control mechanisms and their respective functional blocks.

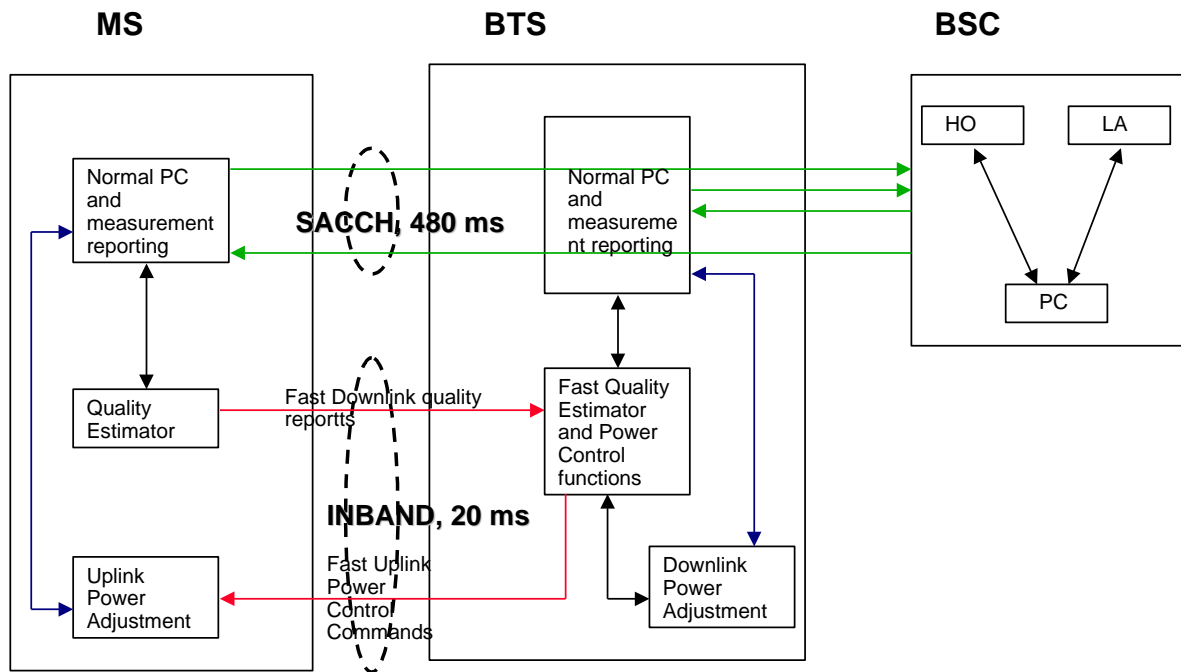

The BSC has the control over which power control loop is in use. This is signalled with one control bit on the Abis interface to the BTS, which in turn informs the MS, when the fast power control loop shall be used. When FPC is not activated, there is no requirement for either the BTS nor the MS to perform quality estimations or sending commands/reports via E-IACCH.

The specific power control algorithm to be used for fast power control is, as is the case for normal power control, implementation dependent and is thus not standardised.

B.7 Interworking between normal and enhanced power control (EPC)

Interworking between normal and enhanced power control (EPC) is done so that the normal power control may be running even if enhanced power control is activated. This means that both the BSS and the MS shall, at all times when in EPC mode, estimate the radio link quality plus send power level commands and link quality reports respectively based on the cycle of the reporting period of length 104 TDMA frames (as specified in subclause 8.4). When EPC in the uplink is activated though, the power level commands sent via SACCH are ignored by the MS.

Switching between normal and enhanced power control always takes place at the beginning of a (normal) reporting period.

The figure below illustrates the simultaneous operation of the two power control mechanisms and their respective functional blocks.

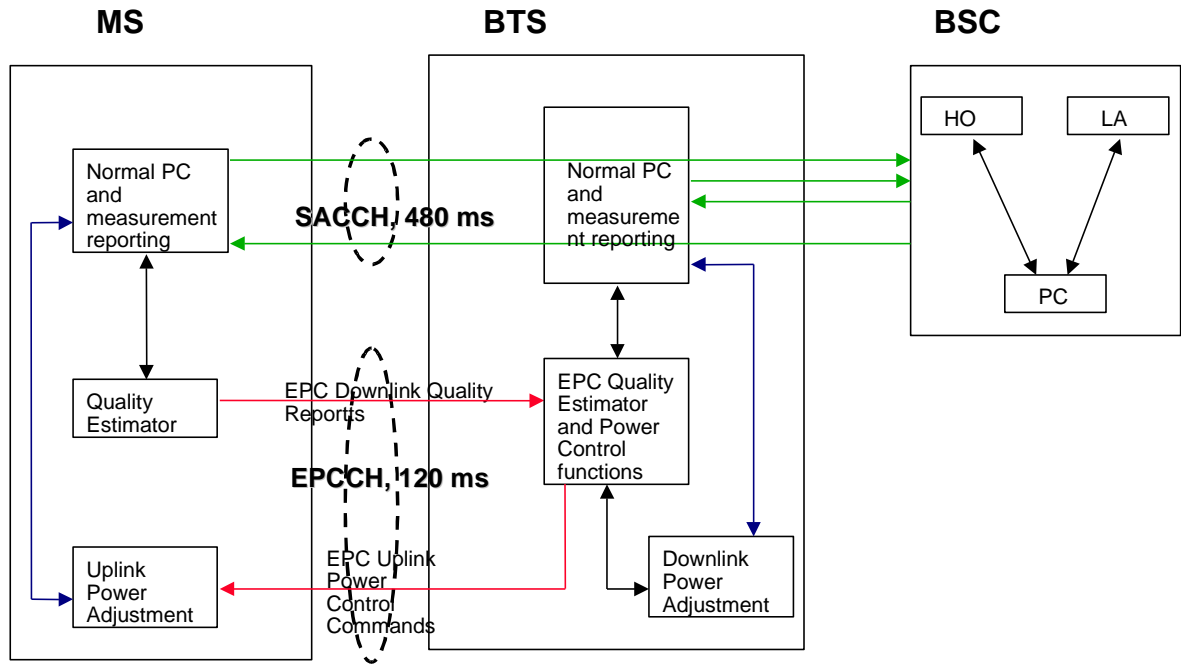

The BSC has the control over which power control loop is in use. For the uplink power control, this is signalled with one control bit on the Abis interface to the BTS, which in turn informs the MS, when the enhanced power control shall be used.

The specific power control algorithm to be used for enhanced power control is, as is the case for normal power control, implementation dependent and is thus not standardised.

Annex C (informative): Example Interference Measurement Algorithm

The following is an example algorithm for interference estimation at the MS during the Training Sequence of a normal burst (GMSK or 8PSK). The same technique may also be employed by the BTS.

The symbol spaced sampled complex envelope of the received signal $r(t)$, $\{r_n\}$, can be expressed as follows:

$$r_n = \sum_{i=-L1}^{L2} c_i u_{n-i} + z_n$$

Where $\{c_i\}$ represents the tap weights of the equivalent channel, $\{u_i\}$ represents the complex symbols of the Training Sequence, z_n represents the interference and noise contribution, and $L1$ and $L2$ are channel dispersion parameters.

STEP 1:

The channel is estimated using the first N symbols of the Training Sequence (where $N < 26$) as follows:

$$\bar{W} = \mathbf{R}^{-1} \bar{P}$$

where \bar{W} represents the estimated equivalent channel response.

$\mathbf{R} = E[\bar{u}_n \bar{u}_n^H]$ is the $K \times K$ correlation matrix of the complex symbols of Training Sequence $\{u_n\}$.

$\bar{P} = E[\bar{u}_n r_n^*]$ denotes the $K \times 1$ cross-correlation vector between the complex symbols of Training Sequence and the received signal sample $\{r_n\}$.

and $\bar{u}_n = [u_n, u_{n-1}, \dots, u_{n-K+1}]^T$.

K will be decided based on the expected maximum equivalent channel dispersion. Note that the equivalent channel corresponds to the combined channel response of the physical channel and transmit and receive filter responses. K represents the number of symbols over which the equivalent channel dispersion is spanning. $K = L1 + L2 + 1$.

STEP 2:

The interference and noise contribution (IN) is calculated for the last $M = 26 - N$ symbols of the Training Sequence as follows:

$$IN = \frac{1}{M} \sum_{k=1}^M |r_k - \bar{W}^* \bar{u}_k|^2$$

Note that the accuracy of the interference estimate will improve as M increases, on other hand the channel estimate may suffer because of a reduced N . Optionally, the symbols in the immediate vicinity on either side of the Training Sequence may also be used in estimating interference.

STEP 3:

The above procedure may be performed in both the directions scanning Training Sequence from left to right and right to left. By scanning in both the directions, IN can be obtained for the first M symbols, $IN1$, and for last M symbols, $IN2$. The interference measurement sample $SS_{CH,n}$ is calculated as follows.

$$SS_{CH,n} = (IN1 + IN2) / 2$$

Annex D (informative): Example Selection of Modulation and Coding Schemes based on Link Quality Reports

The table below gives examples of Modulation and Coding Scheme (MCS) selection based on the reported link quality estimates 8PSK_MEAN_BEP and 8PSK_CV_BEP. The selection is designed to maximise the link throughput. Further optimisation e.g. for the IR mode is possible. In the same manner the MCS -1 to MCS-4 can be chosen based on GMSK_MEAN_BEP and GMSK_CV_BEP and the Modulation and Coding Schemes defined for EGPRS2 can be selected based on the defined modulation specific measurements for MEAN_BEP and CV_BEP.

Table 3: 8PSK MCS selection based on BEP reports

		8PSK_CV_BEP							
		1	2	3	4	5	6	7	8
8 P S K M E A N B E P	1	MCS-5	MCS-5	MCS-5	MCS-5	MCS-5	MCS-5	MCS-5	MCS-5
	2	MCS-5	MCS-5	MCS-5	MCS-5	MCS-5	MCS-5	MCS-5	MCS-5
	3	MCS-5	MCS-5	MCS-5	MCS-5	MCS-5	MCS-5	MCS-5	MCS-5
	4	MCS-5	MCS-5	MCS-5	MCS-5	MCS-5	MCS-5	MCS-5	MCS-5
	5	MCS-5	MCS-5	MCS-5	MCS-5	MCS-5	MCS-5	MCS-5	MCS-5
	6	MCS-5	MCS-5	MCS-5	MCS-5	MCS-5	MCS-5	MCS-5	MCS-6
	7	MCS-5	MCS-5	MCS-5	MCS-5	MCS-5	MCS-5	MCS-5	MCS-6
	8	MCS-5	MCS-5	MCS-5	MCS-5	MCS-5	MCS-5	MCS-6	MCS-6
	9	MCS-5	MCS-5	MCS-5	MCS-5	MCS-5	MCS-6	MCS-6	MCS-6
	10	MCS-5	MCS-5	MCS-5	MCS-5	MCS-6	MCS-6	MCS-6	MCS-6
	11	MCS-5	MCS-5	MCS-6	MCS-6	MCS-6	MCS-6	MCS-6	MCS-6
	12	MCS-6	MCS-6	MCS-6	MCS-6	MCS-6	MCS-6	MCS-6	MCS-7
	13	MCS-6	MCS-6	MCS-6	MCS-6	MCS-6	MCS-6	MCS-7	MCS-7
	14	MCS-6	MCS-6	MCS-6	MCS-6	MCS-6	MCS-7	MCS-7	MCS-7
	15	MCS-6	MCS-6	MCS-7	MCS-7	MCS-7	MCS-7	MCS-7	MCS-7
	16	MCS-7	MCS-7	MCS-7	MCS-7	MCS-7	MCS-7	MCS-7	MCS-7
	17	MCS-7	MCS-7	MCS-7	MCS-7	MCS-7	MCS-7	MCS-7	MCS-7
	18	MCS-7	MCS-7	MCS-7	MCS-7	MCS-7	MCS-7	MCS-7	MCS-7
	19	MCS-7	MCS-7	MCS-7	MCS-7	MCS-7	MCS-7	MCS-7	MCS-7
	20	MCS-7	MCS-7	MCS-7	MCS-7	MCS-7	MCS-7	MCS-7	MCS-7
	21	MCS-7	MCS-7	MCS-7	MCS-7	MCS-7	MCS-7	MCS-7	MCS-7
	22	MCS-7	MCS-7	MCS-8	MCS-8	MCS-8	MCS-8	MCS-8	MCS-8
	23	MCS-8	MCS-8	MCS-8	MCS-8	MCS-8	MCS-8	MCS-8	MCS-8
	24	MCS-8	MCS-8	MCS-8	MCS-8	MCS-8	MCS-8	MCS-8	MCS-8
	25	MCS-8	MCS-8	MCS-8	MCS-8	MCS-8	MCS-8	MCS-8	MCS-8
	26	MCS-8	MCS-8	MCS-8	MCS-8	MCS-8	MCS-8	MCS-8	MCS-8
	27	MCS-8	MCS-8	MCS-8	MCS-8	MCS-8	MCS-8	MCS-8	MCS-8
	28	MCS-8	MCS-8	MCS-8	MCS-8	MCS-8	MCS-8	MCS-8	MCS-8
	29	MCS-9	MCS-9	MCS-9	MCS-9	MCS-9	MCS-9	MCS-9	MCS-9
	30	MCS-9	MCS-9	MCS-9	MCS-9	MCS-9	MCS-9	MCS-9	MCS-9
	31	MCS-9	MCS-9	MCS-9	MCS-9	MCS-9	MCS-9	MCS-9	MCS-9
	32	MCS-9	MCS-9	MCS-9	MCS-9	MCS-9	MCS-9	MCS-9	MCS-9

Annex E (informative): Change history

SPEC	SMG#	CR	Rev	PHS	VERS	NEW_V	SUBJECT
05.08	s24	A043		R97	5.5.0	6.0.0	Channel Quality Report in GPRS
05.08	s25	A046		R97	6.0.0	6.1.0	Improvements to GPRS power control
05.08	s25	A047		R97	6.0.0	6.1.0	Cell re-selection in GPRS
05.08	s25	A050		R97	6.0.0	6.1.0	Cell re-selection in GPRS
05.08	s25	A051		R97	6.0.0	6.1.0	GPRS Cell Re-selection
05.08	s25	A053		R97	6.0.0	6.1.0	Interference measurements for GPRS
05.08	s25	A054		R97	6.0.0	6.1.0	Renaming of GPRS RR states
05.08	s25	A055		R97	6.0.0	6.1.0	Transmission on downlink PDCH
05.08	s25	A056		R97	6.0.0	6.1.0	RF power level control during configuration change procedure
05.08					6.1.0	6.1.1	Correction of version number
05.08	s26	A057		R97	6.1.0	6.2.0	Corrections and clarifications to GPRS
05.08	s26	A058		R97	6.1.0	6.2.0	Cell re-selection in GPRS
05.08	s26	A059		R97	6.1.0	6.2.0	Mapping of PACCH
05.08	s26	A060		R97	6.1.0	6.2.0	Coding of parameter GCH
05.08	s26	A061		R97	6.1.0	6.2.0	RXQUAL measurement
05.08	s26	A063		R97	6.1.0	6.2.0	Clarification of non-DRX mode
05.08	s26	A064		R97	6.1.0	6.2.0	Release of dedicated channels
05.08	s26	A065		R97	6.1.0	6.2.0	Renaming of broadcast parameters
05.08	s26	A066		R97	6.1.0	6.2.0	Measurement reporting and network controlled cell selection
05.08	s27	A044		R97	6.2.0	6.3.0	MS delay time in reporting a new strongest neighbouring cell
05.08	s27	A068		R97	6.2.0	6.3.0	Clarification of Power Control
05.08	s27	A069		R97	6.2.0	6.3.0	Measurement reporting
05.08	s27	A072		R97	6.2.0	6.3.0	GPRS idle mode measurements
05.08	s27	A074		R97	6.2.0	6.3.0	Clarification of Complete BA (SACCH)
05.08	s27	A075		R97	6.2.0	6.3.0	Tolerances for power control
05.08	s27	A076		R97	6.2.0	6.3.0	GPRS downlink power control
05.08	s28	A080		R97	6.3.0	6.4.0	MS delay time in reporting a new strongest neighbouring cell in GPRS
05.08	s28	A081		R97	6.3.0	6.4.0	Cell re-selection
05.08	s28	A082		R97	6.3.0	6.4.0	Interference measurements on Network command
05.08	s28	A086		R97	6.3.0	6.4.0	Clarification of received signal level
05.08	s28	A087		R97	6.3.0	6.4.0	Interference measurements with frequency hopping
05.08	s28	A088		R97	6.3.0	6.4.0	Clarification of interference measurements
05.08	s28	A089		R97	6.3.0	6.4.0	Call reestablishment procedure for abnormal release with cell reselection in ready state
05.08	s28	A093		R97	6.3.0	6.4.0	Application time of Gamma and Alpha parameters for the computation on MS output power
05.08	s28	A094		R97	6.3.0	6.4.0	Clarification on MAFA measurement requirements
05.08	s28	A096		R97	6.3.0	6.4.0	Cell reselection delay time in packet transfer mode
05.08	s28	A097		R97	6.3.0	6.4.0	Clarification to a requirement to perform the interference measurements
05.08	s28	A098		R97	6.3.0	6.4.0	Neighbour measurements
05.08	s28	A099		R97	6.3.0	6.4.0	End of measurement period for the quality measurements
05.08	s28	A102		R97	6.3.0	6.4.0	Correction to I_LEVEL reporting
05.08	s28	A079		R98	6.4.0	7.0.0	Harmonization between GSM and PCS 1 900 standard
05.08	s28	A084		R98	6.4.0	7.0.0	Introduction of CTS in 05.08
05.08	s28	A100		R98	6.4.0	7.0.0	AMR DTX aspects in signal quality measurements
05.08	s29	A070		R98	7.0.0	7.1.0	Addition of SoLSA functionality
05.08	s29	A104		R98	7.0.0	7.1.0	Clarification of CTS-MS initial synchronisation
05.08	s29	A105		R98	7.0.0	7.1.0	Performance of CTS power control algorithm
05.08	s29	A106		R98	7.0.0	7.1.0	Introduction of quality criteria in CTS idle mode
05.08	s29	A107		R98	7.0.0	7.1.0	Clarification of C2_CTS computation
05.08	s29	A108		R98	7.0.0	7.1.0	Clarification of range delay measurements
05.08	s29	A116		R98	7.0.0	7.1.0	Time to be ready to access a new cell
05.08	s29	A123		R98	7.0.0	7.1.0	Clarification of time of application of new alpha and gamma value in case of time slot reconfiguration

SPEC	SMG#	CR	Rev	PHS	VERS	NEW V	SUBJECT
05.08	s29	A127		R98	7.0.0	7.1.0	Relation between NC_REPORTING_PERIOD and DRX period
05.08	s29	A131		R98	7.0.0	7.1.0	Interference measurement on packet idle mode
05.08	s29	A132		R98	7.0.0	7.1.0	Clarification to the interference measurements requirements in packet idle mode
05.08	s29	A133		R98	7.0.0	7.1.0	Cell selection parameters in Packet Measurement Order
05.08	s29	A134		R98	7.0.0	7.1.0	Calculation of SIGN_VAR
05.08	s29	A135		R98	7.0.0	7.1.0	Updating of PBCCH information
05.08	s29	A137		R98	7.0.0	7.1.0	Downlink Power Control for GPRS
05.08	s29	A141		R98	7.0.0	7.1.0	Periodic search for SoLSA cell in idle mode
05.08	s29	A145		R98	7.0.0	7.1.0	PC_MEAS_CHAN in case of downlink power control
05.08	s29	A146		R98	7.0.0	7.1.0	RXQUAL in CS4
05.08	s29	A150		R98	7.0.0	7.1.0	Corrections to cell selection for GPRS
05.08	s29	A151		R98	7.0.0	7.1.0	Clarifications to network controlled cell re-selection
05.08	s29	A153		R98	7.0.0	7.1.0	Clarification to network controlled cell re-selection
05.08	s29	A085		R99	7.1.0	8.0.0	EDGE on the BCCH carrier
05.08	s29	A144		R99	7.1.0	8.0.0	GSM 400 bands introduced in 05.08
05.08	s30	A158		R99	8.0.0	8.1.0	Clarification of idle mode support for SoLSA
05.08	s30	A162		R99	8.0.0	8.1.0	Cell re-selection when PBCCH does not exist
05.08	s30	A165		R99	8.0.0	8.1.0	Correction of C filtering
05.08	s30	A168		R99	8.0.0	8.1.0	Clarification of extended measurements
05.08	s30	A170		R99	8.0.0	8.1.0	Multiband cell selection and reporting
05.08	s30	A173		R99	8.0.0	8.1.0	Cell selection parameters in NC_FREQUENCY_LIST
05.08	s30	A176		R99	8.0.0	8.1.0	Power control measurements
05.08	s30	A179		R99	8.0.0	8.1.0	Clarification of RXQUAL for CS4
05.08	s30	A185		R99	8.0.0	8.1.0	Clarification to interference measurements in packet mode changes
05.08	s30	A188		R99	8.0.0	8.1.0	Correction of fixed allocation mode reference that should be "half duplex mode"
05.08	s30	A193		R99	8.0.0	8.1.0	Downlink Power Control for GPRS
05.08	s30b	A147		R99	8.1.0	8.2.0	Fast Power Control for ECSD
05.08	s30b	A180		R99	8.1.0	8.2.0	COMPACT Cell Selection and Reselection
05.08	s30b	A181		R99	8.1.0	8.2.0	Link Quality Control measurements for EGPRS
05.08	s30b	A199		R99	8.1.0	8.2.0	Interference measurements - Alignment 05.08 to 04.60
05.08	s30b	A202		R99	8.1.0	8.2.0	Clarification of channel quality reporting period
05.08	s30b	A206		R99	8.1.0	8.2.0	Downlink Power Control
05.08	s30b	A222		R99	8.1.0	8.2.0	Clarification of timeslots on which to make interference measurements
05.08	s30b	A228		R99	8.1.0	8.2.0	Interference measurements in packet idle mode
05.08	MCC			R99	8.2.0	8.2.1	Figures B1 and also B2 have been updated according to the agreed CR A057. The changes have been missed due to the lack of revision marks.
05.08	s31	A203		R99	8.2.1	8.3.0	COMPACT interference measurements
05.08	s31	A207		R99	8.2.1	8.3.0	Enhanced Measurement Reporting
05.08	s31	A231		R99	8.2.1	8.3.0	Clarification of Extended Measurement requirements
05.08	s31	A232		R99	8.2.1	8.3.0	Correction of measurement filtering for power control
05.08	s31	A233		R99	8.2.1	8.3.0	Enhanced Measurement Reporting for (E)GPRS
05.08	s31	A234		R99	8.2.1	8.3.0	COMPACT RF power control
05.08	s31	A240		R99	8.2.1	8.3.0	EGPRS Link Quality Control measurements
05.08	s31	A243		R99	8.2.1	8.3.0	Missing GSM 850 requirements for Classic BCCH
05.08	s31	A244		R99	8.2.1	8.3.0	Introduction of Example of EGPRS Link Adaptation Algorithm
05.08	s31b	A242		R99	8.3.1	8.4.0	Inter System Handover and Cell re-selection
05.08	s31b	A248		R99	8.3.1	8.4.0	Removal of parameter CELL_RESELECT_PARAM_IND
05.08	s31b	A270		R99	8.3.1	8.4.0	Procedures for inter-system handover (cdma2000)
05.08	s31b	A252		R99	8.3.1	8.4.0	Correction to mapping of interference levels
05.08	s31b	A253		R99	8.3.1	8.4.0	Clarification on Abnormal Cell Reselection
05.08	s31b	A269		R99	8.3.1	8.4.0	System Information refreshing in idle mode
05.08	s31b	A271		R99	8.3.1	8.4.0	MS behaviour under network controlled cell reselection
05.08	s31b	A272		R99	8.3.1	8.4.0	Cell selection parameter acquisition in Packet Transfer mode
05.08	s31b	A273		R99	8.3.1	8.4.0	BTS Output Power
05.08	s31b	A274		R99	8.3.1	8.4.0	Default value for GPRS_MS_TXPWR_MAX_CCH at cell re-selection
05.08	s31b	A249		R99	8.3.1	8.4.0	Clarification of Cell Bar Qualify 2 parameter
05.08	s31b	A266		R99	8.3.1	8.4.0	Fast inband signalling: E-IACCH

SPEC	SMG#	CR	Rev	PHS	VERS	NEW_V	SUBJECT
05.08	s31b	A268		R99	8.3.1	8.4.0	EGPRS Link Quality measurements
05.08	s32	A275		R99	8.4.0	8.5.0	COMPACT interference measurements
05.08	s32	A276		R99	8.4.0	8.5.0	Class A Dual Transfer Mode (DTM)
05.08	s32	A278		R99	8.4.0	8.5.0	Corrections to Inter system Handover and Cell re-selection
05.08	s32	A279		R99	8.4.0	8.5.0	Definition of the SCALE parameter for RXLEV reporting
05.08	s32	A280		R99	8.4.0	8.5.0	Clarification GPRS downlink transmission requirements
05.08	s32	A281		R99	8.4.0	8.5.0	Correction of inconsistency in the handling of BEP_PERIOD2
05.08	s32	A282		R99	8.4.0	8.5.0	Cell_Bar_Access_2 missing in 05.08
05.08	s32	A283		R99	8.4.0	8.5.0	Clarifications on EGPRS measurements
							September 2000 - TSG-GERAN#1
05.08	G01	A287	1	R99	8.5.0	8.6.0	Extended measurement report (MAFA)
05.08	G01	A288	1	R99	8.5.0	8.6.0	Clarifications on EGPRS Quality parameters
05.08	G01	A289	1	R99	8.5.0	8.6.0	Editorial corrections
05.08	G01	A290	1	R99	8.5.0	8.6.0	Clarifications of interference measurements for COMPACT
05.08	G01	A291	1	R99	8.5.0	8.6.0	Corrections to Inter System Handover and Cell re-selection
05.08	G01	A296	1	R99	8.5.0	8.6.0	BTS RF power control
05.08	G01	A297		R99	8.5.0	8.6.0	Correction to measurement reporting for DTM
05.08	G01	A298	1	R99	8.5.0	8.6.0	Corrections to BSIC decoding
							Release 4
05.08	G01	A293		R00	8.6.0	4.0.0	GSM 700 bands introduced in GSM 05.08
					4.0.0	4.0.1	Oct 2000: References corrected.
							November 2000 - TSG-GERAN#2
05.08	G02	001	1	Rel-4	4.0.1	4.1.0	EGPRS Channel Quality Report reporting period
05.08	G02	002		Rel-4	4.0.1	4.1.0	GPRS neighbour cell measurement exceptions
05.08	G02	003	2	Rel-4	4.0.1	4.1.0	Corrections to Handover and Cell re-selection
05.08	G02	004	1	Rel-4	4.0.1	4.1.0	GPRS cell reselection with Packet Measurement Order
05.08	G02	005	1	Rel-4	4.0.1	4.1.0	Corrections to Enhanced Measurement Reporting
05.08	G02	006	1	Rel-4	4.0.1	4.1.0	Maximum number of neighbour cell carriers to be monitored by the MS
05.08	G02	007	1	Rel-4	4.0.1	4.1.0	Discontinuous transmission
05.08	G02	008		Rel-4	4.0.1	4.1.0	Measurement requirements for COMPACT MS in the case of multislot allocations
					4.1.0	4.1.1	Front page layout correction
							January 2001 - TSG-GERAN#3
05.08	G03	009		Rel-4	4.1.1	4.2.0	Handling of missing gamma values
05.08	G03	010		Rel-4	4.1.1	4.2.0	Removal of Anonymous Access
05.08	G03	011		Rel-4	4.1.1	4.2.0	Measurements during polling response transmission
05.08	G03	012		Rel-4	4.1.1	4.2.0	Fine tuning of GPRS cell reselection
05.08	G03	013		Rel-4	4.1.1	4.2.0	Multi-RAT measurements
05.08	G03	015	1	Rel-4	4.1.1	4.2.0	3G Cell re-selection with only frequency information
05.08	G03	016	1	Rel-4	4.1.1	4.2.0	Addition of GSM Blind Handover requirement
05.08	G03	014		Rel-5	4.2.0	5.0.0	Introduction of Wideband AMR for GMSK modulated speech channel

Change history							
Date	TSG GERAN#	TSG Doc.	CR	Rev	Subject/Comment	Old	New
2001-01	03	GP-010243	014		Introduction of Wideband AMR for GMSK modulated speech channel	4.2.0	5.0.0
2001-04	04	GP-010799	018	1	Blind Cell re-selection synchronisation failure	5.0.0	5.1.0
2001-04	04	GP-010579	020		Editorial correction to measurement reporting	5.0.0	5.1.0
2001-04	04	GP-010581	022		Clarification of LSA identification	5.0.0	5.1.0
2001-04	04	GP-010874	024	1	Dynamic ARFCN mapping	5.0.0	5.1.0
2001-04	04	GP-010656	026		Clarifications on System Information Type 2 quarter decoding	5.0.0	5.1.0
2001-04	04	GP-010659	028		Correction on NBR_RCVD_BLOCKS counting	5.0.0	5.1.0
2001-04	04	GP-010916	034		Introduction of UTRAN blind search from the PSI3 quarter	5.0.0	5.1.0
2001-06	05	GP-011417	036	2	Clarifications due to equivalent PLMN	5.1.0	5.2.0
2001-06	05	GP-011045	038		Missing default values for measurement parameters	5.1.0	5.2.0
2001-06	05	GP-011048	040		Invalid BSIC: Terminology alignment	5.1.0	5.2.0
2001-08	06	GP-011526	044		RXQUAL_SUB and RXLEV_SUB with AMR-NB	5.2.0	5.3.0
2001-08	06	GP-011863	052	1	Correction to Predefined Configurations	5.2.0	5.3.0
2001-08	06	GP-011866	056	1	3G reselection: suitable cell and amount to monitor	5.2.0	5.3.0
2001-08	06	GP-011676	059		Introduction of enhanced power control	5.2.0	5.3.0
2001-11	07	GP-012223	061		Clarification on Packet Enhanced Measurement Reporting	5.3.0	5.4.0
2001-11	07	GP-012353	062		Introduction of adaptive half rate speech channels with 8-PSK modulation	5.3.0	5.4.0
2001-11	07	GP-012356	063		Introduction of accuracy requirements for RXQUAL_EPC	5.3.0	5.4.0
2001-11	07	GP-012775	065	1	Correction of references to relevant 3GPP specifications	5.3.0	5.4.0
2001-11	07	GP-012397	069		Number of cells/frequencies to be monitored by a dual mode terminal	5.3.0	5.4.0
2001-11	07	GP-012761	071	1	Correction of parameters related to enhanced and 3G measurements	5.3.0	5.4.0
2001-11	07	GP-012412	073		NDRX definition	5.3.0	5.4.0
2001-11	07	GP-012487	075		Corrections and improvements for abnormal cell reselection	5.3.0	5.4.0
2001-11	07	GP-012490	077		Clarification on UTRAN FDD RSSI reporting	5.3.0	5.4.0
2001-11	07	GP-012499	083		Alignment of predefined configuration handling according to RAN 2 views	5.3.0	5.4.0
2002-02	08	GP-020507	086	2	3G-GSM clarification on RSSI, FDD valid cell and MULTIRAT_REPORTING	5.4.0	5.5.0
2002-02	08	GP-020358	089		Clarification on the usage of Qsearch_P when broadcast on the BCCH	5.4.0	5.5.0
2002-04	09	GP-021231	088	2	Conversion of cell re-selection parameters	5.5.0	5.6.0
2002-04	09	GP-020651	092		NBR_RCVD_BLOCKS for 14.4 non-transparent data	5.5.0	5.6.0
2002-04	09	GP-020653	094		MEAN_BEP measurements on SACCH	5.5.0	5.6.0
2002-04	09	GP-020647	095		Removal of Fixed Allocation	5.5.0	5.6.0
2002-04	09	GP-020986	108		Correction of the initial value of C when entering in packet transfer mode	5.5.0	5.6.0
2002-04	09	GP-021121	110	1	Correction of the SIGN_VAR value to be sent in repeated PACKET RESOURCE REQUEST message	5.5.0	5.6.0
2002-04	09	GP-021006	112		Clarification to priorities between GPRS interference measurements and InterRAT measurements	5.5.0	5.6.0
2002-04	09	GP-021151	113	1	lu mode indication on BCCH in Rel-5	5.5.0	5.6.0
2002-04	09	GP-021153	114		Removal of basic physical subchannel references for EPC	5.5.0	5.6.0
2002-06	10	GP-021839	115	1	Editorial clean up of references	5.6.0	5.7.0
2002-06	10	GP-021415	116		RXQUAL_SUB performance requirement for AMR during speech periods	5.6.0	5.7.0
2002-06	10	GP-021418	118		Correction on the applicability of reporting priority	5.6.0	5.7.0
2002-06	10	GP-021955	119	1	Clarification for EMR on SDCCH	5.6.0	5.7.0
2002-06	10	GP-021422	121		EMR in case of signalling only mode	5.6.0	5.7.0

2002-06	10	GP-021425	123		Correction to cell reselection time requirement (GSM to UTRAN FDD)	5.6.0	5.7.0
2002-06	10	GP-021431	125		Correction on call re-establishment for multimode terminals	5.6.0	5.7.0
2002-06	10	GP-022066	127	1	Removal of CBQ2	5.6.0	5.7.0
2002-06	10	GP-021630	128		Removal of obsolete reference to DRX parameters	5.6.0	5.7.0
2002-06	10	GP-021928	130	1	Correction: validity period of NC_FREQUENCY_LIST	5.6.0	5.7.0
2002-06	10	GP-022021	135		Inclusion of AMR-WB on O-TCH	5.6.0	5.7.0
2002-08	11	GP-022645	131	2	Power control for lu mode	5.7.0	5.8.0
2002-08	11	GP-022644	136	1	8-PSK on the BCCH carrier	5.7.0	5.8.0
2002-08	11	GP-022741	137	2	Introduction of lu mode terminology	5.7.0	5.8.0
2002-08	11	GP-022502	138		Clarification to MS output power	5.7.0	5.8.0
2002-11	12	GP-023423	139	1	Applicability of broadcast parameters versus default point-to-point messages	5.8.0	6.0.0
2002-11	12	GP-023403	142	2	Clarification to cell selection parameter acquisition from neighbour cells while in packet idle mode in a cell without PCCCH	5.8.0	6.0.0
2002-11	12	GP-023312	143	1	Clarification to cells reselection list to use for an MS autonomous cell reselection	5.8.0	6.0.0
2002-11	12	GP-023313	144	1	Clarification to GPRS cell reselection use in Packet Measurement Order message	5.8.0	6.0.0
2002-11	12	GP-023406	145	2	RX_QUAL value clarification	5.8.0	6.0.0
2003-02	13	GP-030149	146		Clarification for EGPRS reporting	6.0.0	6.1.0
2003-02	13	GP-030418	150		Indication of EPC capability	6.0.0	6.1.0
2003-04	14	GP-030863	148	1	BEP estimation accuracy for EMR	6.1.0	6.2.0
2003-04	14	GP-030979	156	1	Use of unbiased variance in the computation of CV_BEP	6.1.0	6.2.0
2003-04	14	GP-030989	158	1	Inconsistency of CBQ3	6.1.0	6.2.0
2003-04	14	GP-030869	163		Power control modes references removal	6.1.0	6.2.0
2003-06	15	GP-031722	168	2	Missing Test Measurement Parameters for UTRAN TDD Cell Access	6.2.0	6.3.0
2003-06	15	GP-031643	169	1	Correction on Cell re-selection parameter acquisition for additional neighbour cells	6.2.0	6.3.0
2003-08	16	GP-032228	172	2	Modification of accuracy requirements for MEAN_BEP for EGPRS	6.3.0	6.4.0
2003-08	16	GP-031783	175	1	Correction on DTM power control	6.3.0	6.4.0
2003-08	16	GP-031924	178		Update on radio sub-system link control parameters	6.3.0	6.4.0
2003-08	16	GP-031925	179		MS power control for packet channels in case of DTM and no valid C value	6.3.0	6.4.0
2003-08	16	GP-032184	180	1	Clarification to Extended Dynamic Allocation for high multislot classes	6.3.0	6.4.0
2003-08	16	GP-031987	183		Correction for identification of TDD cells	6.3.0	6.4.0
2003-08	16	GP-032013	186		Correction to the possibility to test lu mode capability	6.3.0	6.4.0
2003-08	16	GP-032224	194	1	Correction of insufficient range of the FDD_Qmin parameter	6.3.0	6.4.0
2003-08	16	GP-032230	195		Correction to Radio link failure criterion at the physical layer	6.3.0	6.4.0
2003-11	17	GP-032466	196		Flexible Layer One	6.4.0	6.5.0
2003-11	17	GP-032766	201	1	Correction of applicability of NC measurement reporting parameters in context with dedicated mode connections	6.4.0	6.5.0
2004-02	18	GP-040542	198	4	Addition of "cell selection indication" for cell selection at release of TCH or SDCCH	6.5.0	6.6.0
2004-02	18	GP-040485	203	1	DTX Corrections	6.5.0	6.6.0
2004-02	18	GP-040233	204		FLO Corrections	6.5.0	6.6.0
2004-04	19	GP-041197	207	2	Applicability of individual NC parameters	6.6.0	6.7.0
2004-04	19	GP-040699	208		Clarification on BSIC_SEEN reporting	6.6.0	6.7.0
2004-04	19	GP-040813	213		Removal of Unsynchronized (blind) Cell Change Order towards a GSM cell	6.6.0	6.7.0
2004-04	19	GP-040814	214		Removal of GPRS Extended Measurement reporting	6.6.0	6.7.0
2004-04	19	GP-040816	215		Removal of GPRS Idle Interference Measurements	6.6.0	6.7.0
2004-06	20	GP-041260	216		Applicability of cell barring and C1 criterion in NC2 mode	6.7.0	6.8.0

2004-06	20	GP-041667	220	1	Default values for GPRS_RXLEV_ACCESS_MIN and GPRS_MS_TXPWR_MAX_CCH reselection parameters	6.7.0	6.8.0
2004-06	20	GP-041540	223		Clarification of the RXLEV parameter to be compared to Qsearch_C for measurements on other RAT	6.7.0	6.8.0
2004-06	20	GP-041664	224	1	Clarifications and corrections on the Usage of Parameters for Measurements and Reporting	6.7.0	6.8.0
2004-06	20	GP-041569	226		Removal of redundant text	6.7.0	6.8.0
2004-06	20	GP-041695	229		Correction of DTM Output Power Control	6.7.0	6.8.0
2004-08	21	GP-042191	232	1	CPICH RSCP based criterion for GERAN to UTRAN FDD cell reselection	6.8.0	6.9.0
2004-08	21	GP-042232	235	1	Clarifications of BEP Measurements	6.8.0	6.9.0
2004-11	22	GP-042454	225	5	Downlink power control for DTM	6.9.0	6.10.0
2004-11	22	GP-042864	236	5	Usage of C1 and cell barring in NC2	6.9.0	6.10.0
2004-11	22	GP-042329	241		Correction to FDD_RSCPmin parameter usage and change of default value	6.9.0	6.10.0
2004-11	22	GP-042789	242	1	Introduction of MBMS	6.9.0	6.10.0
2004-11	22	GP-042781	243	1	MBMS cell reselection	6.9.0	6.10.0
2004-11	22	GP-042542	245		Improvements to 2G 3G intersystem operability	6.9.0	6.10.0
2004-11	22	GP-042863	249	2	Enhancements to the UTRAN FDD neighbor cell reporting	6.9.0	6.10.0
2004-11	22	GP-042861	250	2	Enhanced control of maximum output power in a common BCCH cell	6.9.0	6.10.0
2005-01	23	GP-050587	254	1	Correction for maximum TX power for CS access on common BCCH cells	6.10.0	6.11.0
2005-01	23	GP-050483	255	1	Provision of cell reselection parameters for neighbouring cells in the serving cell	6.10.0	6.11.0
2005-01	23	GP-050278	258		Clarifications to PR mode B	6.10.0	6.11.0
2005-01	23	GP-050297	261		Correction of reference specification for mapping of 3G measurements	6.10.0	6.11.0
2005-04	24	GP-050869	263		2G-3G cell reselection without PBCCH	6.11.0	6.12.0
2005-06	25	GP-051469	266		UE power class correction factor for FDD_RSCPmin and alignment of 2G to 3G cell reselection criteria between Pre-R5 and R5 mobile stations	6.12.0	6.13.0
2005-09	26	GP-052314	0269	1	Clarification of RXQUAL_EPC measurements	6.13.0	6.14.0
2005-09	26	GP-052158	0275		Calculation and reporting of EGPRS quality parameters	6.14.0	7.0.0
2005-09	26	GP-052159	0276		Accuracy requirements of MS MEAN_BEP estimate	6.14.0	7.0.0
2005-09	26	GP-052231	0277		Correction to MEAN_BEP and CV_BEP calculations when new timeslot configuration is allocated during a downlink EGPRS TBF	6.14.0	7.0.0
2005-11	27	GP-052817	0278	1	Clarification to usage of uplink power control parameters provided on PACCH	7.0.0	7.1.0
2005-11	27	GP-052460	0280		Correction to the list of logical channels where LB_MS_TXPWR_MAX_CCH is sent	7.0.0	7.1.0
2005-11	27	GP-052750	0286	1	RSCP suitability criterion parameters handling	7.0.0	7.1.0
2005-11	27	GP-052917	0290	3	Accuracy requirements of MS MEAN_BEP estimation: removal of brackets	7.0.0	7.1.0
2006-01	28	GP-060015	0298		Incorrect formula references	7.1.0	7.2.0
2006-01	28	GP-060134	0299		Removal of fixed allocation related text	7.1.0	7.2.0
2006-01	28	GP-060136	0301		Clarification for GPRS_RESELECT_OFFSET conversion from CELL_RESELECT_OFFSET	7.1.0	7.2.0
2006-01	28	GP-060392	0302	1	Alignment of Barred Cell with EHPLMN	7.1.0	7.2.0
2006-04	29	GP-060651	0300	2	DTM interference measurements	7.2.0	7.3.0
2006-04	29	GP-060840	0307	2	Performance enhancement for cell reselection with partial roaming restrictions on the target RAT (UTRAN)	7.2.0	7.3.0
2006-04	29	GP-060650	0310		Correction for the UTRAN RSCP mapping	7.2.0	7.3.0
2006-04	29	GP-060937	0311	1	Introduction of restrictions for BTS operation in the case of TX antenna hopping	7.2.0	7.3.0
2006-04	29	GP-060837	0312		Cleanup subsequent to removal of GPRS Idle Interference Measurements	7.2.0	7.3.0
2006-04	29	GP-060993	0313	1	Reporting cells not present in the GSM Neighbour Cell list	7.2.0	7.3.0
2006-06	30	GP-061469	0316	2	C value calculation in case there is a transition of	7.3.0	7.4.0

					the mode		
2006-06	30	GP-061340	0317	1	Default values of SERVING_BAND_REPORTING and REP_PRIORITY in table 3	7.3.0	7.4.0
2006-06	30	GP-061335	0318	1	Clarification of the NC mode when receiving Packet Cell Change Order message	7.3.0	7.4.0
2006-06	30	GP-061112	0319		Correction of terminology: 'allocation' vs. 'assignment'	7.3.0	7.4.0
2006-09	31	GP-061851	0322	1	The default values of optional parameters used in the calculation of cell ranking criterion parameter	7.4.0	7.5.0
2006-09	31	GP-061924	0323	4	Enhancement to Extended Dynamic Allocation for high multislot classes	7.4.0	7.5.0
2006-09	31	GP-061857	0325		C value calculation in case of PS handover	7.4.0	7.5.0
2006-10					Restored "carriage return" mistakenly removed in GP-061924 CR 0323 rev 4 (clause 10.1.1.2)	7.5.0	7.5.1
2006-11	32	GP-062072	0326		The default value of HCS_THR	7.5.1	7.6.0
2006-11	32	GP-062456	0327	3	The report on MEAN_BEP and CV_BEP in packet transfer mode	7.5.1	7.6.0
2007-02	33	GP-070365	0329	2	Radio blocks for channel quality reporting	7.6.0	7.7.0
2007-02	33	GP-070166	0332		Monitoring and reporting of UTRAN cells that are abandoned for cell reselection	7.6.0	7.7.0
2007-02	33	GP-070514	0336	1	Clarification of the lists used in multi-RAT network controlled cell re-selection	7.6.0	7.7.0
2007-02	33	GP-070518	0337	2	Introduction of downlink dual carrier	7.6.0	7.7.0
2007-05	34	GP-070791	0340		Clarifications and editorial corrections	7.7.0	7.8.0
2007-08	35	GP-071487	0341	1	Clarification on the broadcast channel for measurement parameters	7.8.0	7.9.0
2007-08	35	GP-071488	0342	1	Clarification of the applicability rules for the lists used in multi-RAT network controlled cell re-selection	7.8.0	7.9.0
2007-11	36	GP-071968	0344	1	Corrections for Reduced TTI	7.9.0	7.10.0
2007-11	36	GP-071766	0345		Introduction of EGPRS2-A and EGPRS2-B	7.9.0	7.10.0
2007-11	36	GP-071841	0346		Initialization of the counter DSC	7.9.0	7.10.0
2008-02	37	GP-080294	0350	1	Power level definition for PS Handover Access	7.10.0	7.11.0
2008-02	37	GP-080140	0351		Channel quality measurements at resource reallocation	7.10.0	7.11.0
2008-08	39	GP-081420	0361		Channel quality measurement and reporting	7.11.0	7.12.0
2008-08	39	GP-081346	0352	3	Introduction of GERAN to E-UTRAN interworking	7.12.0	8.0.0
2008-11	40	GP-081797	0362	1	Corrections for GERAN to E-UTRAN interworking	8.0.0	8.1.0
2008-11	40	GP-081909	0363	1	Priority of the higher order modulation scheme for EGPRS2 channel quality reporting	8.0.0	8.1.0
2008-11	40	GP-081798	0366	2	Introduction of RSCPmin for TDD UTRAN reselection	8.0.0	8.1.0
2008-11	40	GP-081907	0370	2	Output power decrease on the BCCH carrier, EGPRS2	8.0.0	8.1.0
2008-11	40	GP-081653	0371		Definition of measurement and reporting parameters for E-UTRAN	8.0.0	8.1.0
2009-02	41	GP-090423	0368	3	EGPRS2 Link quality reporting	8.1.0	8.2.0
2009-02	41	GP-090443	0372	1	Introduction of mobility to CSG in GERAN	8.1.0	8.2.0
2009-02	41	GP-090531	0377	1	Modification to cell reselection from GSM to UTRAN TDD	8.1.0	8.2.0
2009-02	41	GP-090540	0378	2	Individual (dedicated) priorities	8.1.0	8.2.0
2009-02	41	GP-090474	0379	1	Corrections to requirements for E-UTRAN interworking	8.1.0	8.2.0
2009-02	41	GP-090449	0381	2	Introduction of the PCID group mapping to the Tracking Area	8.1.0	8.2.0
2009-02	41	GP-090539	0382	3	Clarification of Measurement for Cell reselection	8.1.0	8.2.0
2009-05	42	GP-090990	0383	3	Correction to applicability of S_serving	8.2.0	8.3.0
2009-05	42	GP-091044	0384	2	Further essential corrections for GERAN to E-UTRAN interworking	8.2.0	8.3.0
2009-05	42	GP-090994	0385	1	Clarification of usage of E-UTRAN MEASUREMENT REPORT OFFSET	8.2.0	8.3.0
2009-05	42	GP-090993	0386	1	Correction on GPRS cell reselection algorithm based on priority information	8.2.0	8.3.0
2009-05	42	GP-090974	0392	1	EGPRS2 link quality reporting – removal of reporting of all modulations	8.2.0	8.3.0
2009-09	43	GP-091662	0393	1	Priority based reselection to UTRAN	8.3.0	8.4.0

2009-09	43	GP-091734	0394	2	Measurements on higher priority inter-RAT frequency	8.3.0	8.4.0
2009-09	43	GP-091666	0395	1	Clarification on CSG PSC/ PCI split information	8.3.0	8.4.0
2009-09	43	GP-091768	0397	2	Correction on Measurement Control	8.3.0	8.4.0
2009-09	43	GP-091685	0398	1	3G_SEARCH_PRIO definition update	8.3.0	8.4.0
2009-09	43	GP-091300	0401		Removal of brackets, BCCH backoff	8.3.0	8.4.0
2009-09	43	GP-091733	0402	2	Correction of parameter range for THRESH_GSM_low and clarification of THRESH_priority_search usage	8.3.0	8.4.0
2009-09	43	GP-091589	0403	1	Essential GELTE corrections	8.3.0	8.4.0
2009-09	43	GP-091680	0408		EGPRS2 link quality reporting – removal of brackets	8.3.0	8.4.0
2009-09	43	GP-091732	0409	1	Qsearch_C_E-UTRAN_Initial coding update	8.3.0	8.4.0
2009-09	43	GP-091687	0399	1	Introduction of VAMOS power control	8.4.0	9.0.0
2009-09	43	GP-091334	0405		Support of hybrid cells	8.4.0	9.0.0
2009-11	44	GP-092154	0412	2	Corrections to 3G_SEARCH_PRIO	9.0.0	9.1.0
2009-11	44	GP-092156	0414	1	Corrections to requirements for priority-based reselection	9.0.0	9.1.0
2009-11	44	GP-092158	0416	1	Correction to default value for THRESH_E-UTRAN_low	9.0.0	9.1.0
2009-11	44	GP-092323	0418	1	Correction on autonomous search of CSG cell	9.0.0	9.1.0
2009-11	44	GP-092330	0420	1	Removal of E-UTRAN_BA_IND	9.0.0	9.1.0
2009-11	44	GP-092349	0423	1	Removal of mandatory support for P-channels by mobile stations in A/Gb mode	9.0.0	9.1.0
2009-11	44	GP-092325	0425	1	Further corrections to requirements for priority-based reselection	9.0.0	9.1.0
2009-11	44	GP-092328	0429	1	Abnormal cases for cell re-selection based on priority information	9.0.0	9.1.0
2009-11	44	GP-091934	0431		Corrections related to the removal of E-UTRAN information from PBCCH	9.0.0	9.1.0
2010-03	45	GP-100611	0432	3	Introduction of new SACCH message block for Shifted SACCH in VAMOS	9.1.0	9.2.0
2010-03	45	GP-100522	0434	1	Miscellaneous correction	9.1.0	9.2.0
2010-03	45	GP-100588	0437	2	Clean up E-UTRAN measurement parameters	9.1.0	9.2.0
2010-03	45	GP-100504	0439	1	Add requirements for re-reporting UTRAN TDD cells	9.1.0	9.2.0
2010-03	45	GP-100579	0441	2	Essential GERAN-LTE corrections	9.1.0	9.2.0
2010-03	45	GP-100593	0445	1	Reception of PWS warning notifications in an acceptable cell	9.1.0	9.2.0
2010-05	46	GP-101018	0422	3	Support of inbound mobility to CSG cells	9.2.0	9.3.0
2010-05	46	GP-101020	0446	2	Cell reselection enhancements	9.2.0	9.3.0
2010-05	46	GP-101011	0448	1	Further correction on priority based cell re-selection	9.2.0	9.3.0
2010-05	46	GP-100783	0456		Correction of EGPRS2A Measurement Reporting	9.2.0	9.3.0
2010-05	46	GP-101016	0458	1	T_reselection Clarification for CSG Cells	9.2.0	9.3.0
2010-05	46	GP-101019	0460	1	Definition of hybrid cells	9.2.0	9.3.0
2010-05	46	GP-101003	0464		Correction for RSSI reporting	9.2.0	9.3.0
2010-05	46	GP-101046	0465	1	Correction for Rel-8 CSG mobility	9.2.0	9.3.0
2010-09	47	GP-101559	0451	2	Redirection from E-UTRAN to GERAN	9.3.0	9.4.0
2010-09	47	GP-101534	0468	1	MEAN_BEP performance requirements for 16-QAM and 32-QAM	9.3.0	9.4.0
2010-09	47	GP-101553	0471	1	Miscellaneous correction	9.3.0	9.4.0
2010-09	47	GP-101645	0478	3	Corrections to CSG requirements	9.3.0	9.4.0
2010-09	47	GP-101616	0479	2	Reselection rules for hybrid cells	9.3.0	9.4.0
2010-09	47	GP-101610	0480	1	Reporting rules for hybrid cells	9.3.0	9.4.0
2010-11	48	GP-102059	0483	1	CSFB with Redirection & System Information	9.4.0	9.5.0
2010-11	48	GP-101751	0486		MEAN_BEP performance requirements for EGPRS2-A 16-QAM and 32-QAM – removal of brackets	9.4.0	9.5.0
2010-11	48	GP-101805	0488		Remove conflicting IRAT measurement requirement	9.4.0	9.5.0
2010-11	48	GP-101828	0489		Corrections to CSG requirements	9.4.0	9.5.0
2011-03	49	GP-110491	0490	3	Rules for reporting of detected hybrid cells not as CSG cells	9.5.0	9.6.0
2011-03	49	GP-110477	0492	3	Corrections to cell reporting requirements for multi-RAT MS	9.5.0	9.6.0
2011-03	49	GP-110151	0494		Corrections on definition of XXX_REPORTING_OFFSET	9.5.0	9.6.0
2011-03	49	GP-110462	0502	2	Correction on priority based reselection for low priority cells	9.5.0	9.6.0

2011-03	49	GP-110457	0509	1	Link quality measurement reporting restrictions for downlink dual carrier	9.5.0	9.6.0
2011-03	49	GP-110514	0506	3	Power level for RACH	9.6.0	10.0.0
2011-03	49	GP-110242	0511		Miscellaneous corrections to Link quality measurement reporting	9.6.0	10.0.0
2011-05	50	GP-110599	0515		Reporting priority between CSG cells from different RATs/modes	10.0.0	10.1.0
2011-05	50	GP-110905	0517	1	Corrections to CSG reporting thresholds	10.0.0	10.1.0
2011-05	50	GP-110956	0518	1	Alignment of inter-RAT measurement requirements with RAN specifications	10.0.0	10.1.0
2011-05	50	GP-110903	0521	1	Completion of the autonomous search function performance requirements for CSG cells and hybrid cells, correction to CSG cells re-selection requirements and to inbound mobility to CSG cells in packet transfer mode	10.0.0	10.1.0
2011-05	50	GP-110954	0524	2	Correction on Measurement Reporting Threshold	10.0.0	10.1.0
2011-05	50	GP-110885	0527	1	Correction on Definition of Reported Value and non-Reported Value	10.0.0	10.1.0
2011-05	50	GP-110887	0529	2	Miscellaneous Corrections	10.0.0	10.1.0
2011-05	50	GP-110928	0531	2	Measurement reporting accuracy requirements for VAMOS mode	10.0.0	10.1.0
2011-05	50	GP-110925	0532	2	Measurement reporting limits for CSG cells	10.0.0	10.1.0
2011-05	50	GP-110642	0534		Measurement reporting for CSG cells – missing reference	10.0.0	10.1.0
2011-05	50	GP-110649	0537		Validity of stored measurement parameters correction	10.0.0	10.1.0
2011-05	50	GP-110872	0539	1	Average power decrease for AQPSK	10.0.0	10.1.0
2011-09	51	GP-111456	0544	2	Correction on CSG membership check in idle mode	10.1.0	10.2.0
2011-09	51	GP-111467	0547	2	Clarification for measurement control parameter on SACCH	10.1.0	10.2.0
2011-09	51	GP-111364	0549	1	Clarification for RXQUAL requirements for VAMOS mode	10.1.0	10.2.0
2011-09	51	GP-111385	0554	1	Priority-based reselection: corrections and clarifications	10.1.0	10.2.0
2011-09	51	GP-111453	0556	2	Measurement reporting limits for CSG cells – removal of brackets	10.1.0	10.2.0
2011-09	51	GP-111471	0558	1	Correction on CSG membership check in connected mode	10.1.0	10.2.0
2011-11	52	GP-111868	0535	2	Storage and usage of suitability requirements from UTRAN cells	10.2.0	10.3.0
2011-11	52	GP-111557	0561		Removal of square brackets from interworking related requirements	10.2.0	10.3.0
2011-11	52	GP-111592	0563		Removal of square brackets in MEAN_BEP AQPSK mapping tables	10.2.0	10.3.0
2011-11	52	GP-111800	0565	1	Clarification on CSG reporting requirements and procedures	10.2.0	10.3.0
2011-11	52	GP-111749	0567		Removal of brackets for VAMOS BTS requirements	10.2.0	10.3.0
2012-03	53	GP-120299	0575	1	Alignment of support of priority based reselection enhancements	10.3.0	10.4.0
2012-03	53	GP-120417	0578	2	Correction on Qsearch_P(_E-UTRAN) and measurement control applicability	10.3.0	10.4.0
2012-03	53	GP-120174	0581		Correction to priority-based reselection when GPRS reselection parameters are applicable	10.3.0	10.4.0
2012-03	53	GP-120300	0582	1	Use of frequency-specific UTRAN suitability parameters	10.4.0	11.0.0
2012-05	54	GP-120576	0584		Introduction of NCC_PERMITTED for idle mode	11.0.0	11.1.0
2012-05	54	GP-120589	0586		Removal of brackets for measured signal strength threshold for power reduction on RACH	11.0.0	11.1.0
2012-08	55	GP-121130	0587	1	Introduction of NCC_PERMITTED for FULL-MOCN mobiles	11.1.0	11.2.0
2013-03	57	GP-130281	0596	2	System Information acquisition for CS Fallback with Cell Change Order from E-UTRAN	11.2.0	11.3.0
2013-03	57	GP-130220	0599		Applicability of system information provided in E-UTRAN for CS Fallback	11.2.0	11.3.0
2013-05	58	GP-130542	0606	1	Broadcast of additional information for Network Sharing related to inter RAT mobility	11.3.0	11.4.0

2013-05	58	GP-130491	0608	1	Clarification to RSRP and RSRQ measurement reporting thresholds	11.3.0	11.4.0
2013-05	58	GP-130474	0609		Applicability of system information provided in E-UTRAN for CS Fallback - correction to implementation of GP-130220	11.3.0	11.4.0
2013-08	59	GP-130877	0592	4	Introduction of wideband RSRQ measurements	11.4.0	11.5.0
2013-08	59	GP-130797	0605	3	Correction of Qsearch_I/Qsearch_C/Qsearch_P for UTRAN TDD	11.4.0	11.5.0