

3GPP TS 44.065 V11.0.0 (2012-09)

Technical Specification

**3rd Generation Partnership Project;
Technical Specification Group Core Network and Terminals;
Mobile Station (MS) - Serving GPRS Support Node (SGSN);
Subnetwork Dependent Convergence Protocol (SNDCP)
(Release 11)**



The present document has been developed within the 3rd Generation Partnership Project (3GPP™) and may be further elaborated for the purposes of 3GPP. The present document has not been subject to any approval process by the 3GPP Organisational Partners and shall not be implemented. This Specification is provided for future development work within 3GPP only. The Organisational Partners accept no liability for any use of this Specification. Specifications and reports for implementation of the 3GPP™ system should be obtained via the 3GPP Organisational Partners' Publications Offices.

Keywords

GSM, GPRS, network, packet mode

3GPP

Postal address

3GPP support office address

650 Route des Lucioles - Sophia Antipolis
Valbonne - FRANCE
Tel.: +33 4 92 94 42 00 Fax: +33 4 93 65 47 16

Internet

<http://www.3gpp.org>

Copyright Notification

No part may be reproduced except as authorized by written permission.
The copyright and the foregoing restriction extend to reproduction in all media.

© 2012, 3GPP Organizational Partners (ARIB, ATIS, CCSA, ETSI, TTA, TTC).
All rights reserved.

UMTS™ is a Trade Mark of ETSI registered for the benefit of its members
3GPP™ is a Trade Mark of ETSI registered for the benefit of its Members and of the 3GPP Organizational Partners
LTE™ is a Trade Mark of ETSI currently being registered for the benefit of its Members and of the 3GPP Organizational Partners
GSM® and the GSM logo are registered and owned by the GSM Association

Contents

Foreword	6
1 Scope	7
2 References.....	7
3 Definitions and abbreviations	8
3.1 Definitions	8
3.2 Abbreviations	9
4 General.....	9
5 Service primitives and functions.....	11
5.1 Service primitives	11
5.1.1 SMDCP service primitives	11
5.1.1.1 SN-DATA.request	12
5.1.1.2 SN-DATA.indication	12
5.1.1.3 SN-UNITDATA.request.....	12
5.1.1.4 SN-UNITDATA.indication.....	12
5.1.1.5 SN-XID.request.....	12
5.1.1.6 SN-XID.indication.....	12
5.1.1.7 SN-XID.response.....	12
5.1.1.8 SN-XID.confirm	12
5.1.2 Service primitives used by SMDCP layer	12
5.1.2.1 LL-RESET.indication	13
5.1.2.2 LL-ESTABLISH.request.....	14
5.1.2.3 LL-ESTABLISH.indication	14
5.1.2.4 LL-ESTABLISH.response.....	14
5.1.2.5 LL-ESTABLISH.confirm.....	14
5.1.2.6 LL-RELEASE.request.....	14
5.1.2.7 LL-RELEASE.indication	14
5.1.2.8 LL-RELEASE.confirm	15
5.1.2.9 LL-XID.request.....	15
5.1.2.10 LL-XID.indication	15
5.1.2.11 LL-XID.response	15
5.1.2.12 LL-XID.confirm.....	15
5.1.2.13 LL-DATA.request	15
5.1.2.14 LL-DATA.indication.....	15
5.1.2.15 LL-DATA.confirm	15
5.1.2.16 LL-UNITDATA.request.....	15
5.1.2.17 LL-UNITDATA.indication	16
5.1.2.18 LL-STATUS.indication	16
5.1.2.19 SNSM-ACTIVATE.indication	16
5.1.2.20 SNSM-ACTIVATE.response	16
5.1.2.21 SNSM-DEACTIVATE.indication	16
5.1.2.22 SNSM-DEACTIVATE.response	16
5.1.2.23 SNSM-MODIFY.indication.....	16
5.1.2.24 SNSM-MODIFY.response.....	17
5.1.2.25 SNSM-STATUS.request	17
5.1.2.26 SNSM-SEQUENCE.indication	17
5.1.2.27 SNSM-SEQUENCE.response	18
5.1.2.28 SNSM-STOP-ASSIGN.indication	18
5.2 Service functions	18
6 Protocol functions	20
6.1 Multiplexing of N-PDUs	20
6.2 Establishment and release of acknowledged peer-to-peer LLC operation	20
6.2.1 Establishment of acknowledged peer-to-peer LLC operation	20
6.2.1.1 Establishment criteria	20

6.2.1.2	Re-establishment of the acknowledged peer-to-peer LLC operation	21
6.2.1.3	Establishment procedure.....	21
6.2.1.4	Exceptional situations	22
6.2.2	Release of acknowledged peer-to-peer LLC operation	22
6.2.2.1	Release criteria	22
6.2.2.2	Release procedure.....	23
6.2.2.3	Release initiated by the LLC layer.....	23
6.3	N-PDU buffering	23
6.4	Management of delivery sequence	23
6.5	Protocol control information compression.....	23
6.5.1	Negotiation of multiple protocol control information compression types	23
6.5.1.1	Format of the protocol control information compression field	24
6.5.1.1.1	Spare bit (X)	24
6.5.1.1.2	Propose bit (P)	24
6.5.1.1.3	Entity number	24
6.5.1.1.4	Algorithm identifier.....	25
6.5.1.1.5	PCOMP.....	25
6.5.1.2	Resetting compression entities following SNDCP XID negotiation	26
6.5.1.3	Parameters for compression entities.....	26
6.5.2	TCP/IP header compression (RFC1144).....	26
6.5.2.1	Parameters	27
6.5.2.1.1	Applicable NSAPIs	27
6.5.2.1.2	S ₀	27
6.5.2.2	Assignment of PCOMP values	27
6.5.2.3	Error Recovery	27
6.5.3	TCP/IP and UDP/IP header compression (RFC 2507)	27
6.5.3.1	Parameters	28
6.5.3.1.1	Applicable NSAPIs	28
6.5.3.2	Assignment of PCOMP values for RFC2507	28
6.5.3.3	Error Recovery	28
6.5.4	Robust Header Compression (ROHC)	28
6.5.4.1	Parameters	29
6.5.4.1.1	Applicable NSAPIs	29
6.5.4.1.2	MAX_CID	29
6.5.4.1.3	MAX_HEADER	29
6.5.4.1.4	(Void).....	29
6.5.4.1.5	PROFILE.....	29
6.5.4.2	Assignment of PCOMP values for ROHC	30
6.5.4.3	Error Recovery and other feedback	30
6.5.5	Pre-defined Protocol control information ROHC compression types for MBMS	30
6.6	Data compression	31
6.6.1	Negotiation of multiple data compression types.....	31
6.6.1.1	Format of the data compression field	32
6.6.1.1.1	Spare bit (X)	32
6.6.1.1.2	Propose bit (P)	32
6.6.1.1.3	Entity number	32
6.6.1.1.4	Algorithm identifier.....	32
6.6.1.1.5	DCOMP	32
6.6.1.2	Resetting compression entities following SNDCP XID negotiation	33
6.6.1.3	Parameters for compression entities.....	33
6.6.2	Management of V.42 bis data compression.....	33
6.6.2.1	Parameters	33
6.6.2.1.1	Applicable NSAPIs	34
6.6.2.1.2	P ₀	34
6.6.2.1.3	P ₁	34
6.6.2.1.4	P ₂	34
6.6.2.2	Assignment of DCOMP values	34
6.6.2.3	Operation of V.42 bis data compression.....	34
6.6.3	Management of V.44 data compression.....	34
6.6.3.1	Parameters	34
6.6.3.1.1	Applicable NSAPIs	35

6.6.3.1.2	C ₀	35
6.6.3.1.3	P ₀	35
6.6.3.1.4	P _{1T}	35
6.6.3.1.5	P _{1R}	36
6.6.3.1.6	P _{3T}	36
6.6.3.1.7	P _{3R}	36
6.6.3.2	Assignment of DCOMP values	36
6.6.3.3	Operation of V.44 data compression	36
6.6.3.3.1	Packet Method	36
6.6.3.3.2	Multi-Packet Method	37
6.7	Segmentation and reassembly	37
6.7.1	General	37
6.7.1.1	Segmentation	37
6.7.1.2	Reassembly	38
6.7.2	Segmentation and reassembly in acknowledged mode	38
6.7.3	Segmentation and reassembly in unacknowledged mode	38
6.7.4	Exception situations	39
6.7.4.1	Receive First Segment state	39
6.7.4.2	Receive Subsequent Segment state	39
6.7.4.3	Discard state	39
6.8	XID parameter negotiation	39
6.8.1	Negotiation of compression entities	42
6.8.1a	Negotiation of SNDCP version	43
6.8.2	Values of SNDCP XID parameters	43
6.8.3	Exception handling	43
6.9	Data transfer	44
6.9.1	Acknowledged mode	44
6.9.2	Unacknowledged mode	45
6.10	Possible combinations of SNDCP protocol functions and their connection to service access points	46
7	Definition of SN-PDU	47
7.1	Format convention	47
7.1.1	Numbering convention	47
7.1.2	Order of transmission	47
7.1.3	Field mapping convention	47
7.2	SN-PDU Formats	48
8	SNDCP XID parameters	49
Annex A (informative): Change History		51

Foreword

This Technical Specification has been produced by the 3rd Generation Partnership Project (3GPP).

The contents of the present document are subject to continuing work within the TSG and may change following formal TSG approval. Should the TSG modify the contents of the present document, it will be re-released by the TSG with an identifying change of release date and an increase in version number as follows:

Version x.y.z

where:

- x the first digit:
 - 1 presented to TSG for information;
 - 2 presented to TSG for approval;
 - 3 or greater indicates TSG approved document under change control.
- y the second digit is incremented for all changes of substance, i.e. technical enhancements, corrections, updates, etc.
- z the third digit is incremented when editorial only changes have been incorporated in the document.

1 Scope

The present document provides the description of the Subnetwork Dependent Convergence Protocol (SNDCP) for the General Packet Radio Service (GPRS).

The user of the services provided by SNDCP is a packet data protocol (PDP) at the mobile Station (MS) or the Relay at the Serving GPRS Support Node (SGSN). Additionally, a control entity, e.g. AT command interpreter, may be an SNDCP user. SNDCP uses the services provided by the Logical Link Control (LLC) layer [4] and the Session Management (SM) sub-layer [2].

The main functions of SNDCP are:

- Multiplexing of several PDPs.
- Compression / decompression of user data.
- Compression / decompression of protocol control information.
- Segmentation of a network protocol data unit (N-PDU) into Logical Link Control Protocol Data Units (LL-PDUs) and re-assembly of LL-PDUs into an N-PDU.

3GPP TS 44.065 is applicable to GPRS MS and SGSN.

2 References

The following documents contain provisions which, through reference in this text, constitute provisions of the present document.

- References are either specific (identified by date of publication, edition number, version number, etc.) or non-specific.
- For a specific reference, subsequent revisions do not apply.
- For a non-specific reference, the latest version applies. In the case of a reference to a 3GPP document (including a GSM document), a non-specific reference implicitly refers to the latest version of that document *in the same Release as the present document*.

- [1] 3GPP TR 21.905: "Vocabulary for 3GPP Specifications".
- [2] 3GPP TS 22.060: "General Packet Radio Service (GPRS); Service Description; Stage 1".
- [3] 3GPP TS 23.060: "General Packet Radio Service (GPRS); Service Description; Stage 2".
- [4] 3GPP TS 24.007: "Mobile radio interface signalling layer 3; General aspects".
- [5] 3GPP TS 44.018: "Mobile radio interface; Layer 3 specification; Radio Resource Control Protocol".
- [5a] 3GPP TS 24.008: "Mobile radio interface; Layer 3 specification; Core Network Protocols; Stage 3".
- [6] 3GPP TS 44.064: "General Packet Radio Service (GPRS); Mobile Station - Serving GPRS Support Node (MS-SGSN) Logical Link Control (LLC) layer specification".
- [7] 3GPP TS 29.060: "General Packet Radio Service (GPRS); GPRS Tunnelling Protocol (GTP) across the Gn and Gp Interface".
- [8] ITU-T Recommendation V.42 bis: "Data compression procedures for data circuit-terminating equipment (DCE) using error correcting procedures".
- [9] IETF RFC 1144: "Compressing TCP/IP headers for low-speed serial links", V. Jacobson.

- [10] IETF RFC 2507: "IP Header Compression", M. Degermark, B. Nordgren, S. Pink.
- [11] ITU-T Recommendation V.44: "Data compression procedures".
- [12] IETF RFC 3095: "RObust Header Compression (ROHC): Framework and four profiles: RTP, UDP, ESP, and uncompressed". C. Bormann et al.
- [13] IETF RFC 3241: "Robust Header Compression (ROHC) over PPP". C. Bormann.
- [14] "RObust Header Compression (ROHC) Profile Identifiers". IANA registry at:
<http://www.iana.org/assignments/rohc-pro-ids>

3 Definitions and abbreviations

3.1 Definitions

For the purposes of the present document, the terms and definitions given in 3GPP TS 21.905 [1] and 3GPP TS 22.060 [2] and the following apply:

Feedback N-PDU: an N-PDU which is generated by an SNDCP protocol control information compression entity or data compression entity and contains only control information for its peer compression entity, but no payload from any SNDCP user.

N201: LLC layer parameter (see 3GPP TS 44.064 [6] for clarity).
Defines maximum number of octets in the information field of LL-PDU. Separate values are applicable for I (see N201-I), U and UI (see N201-U) LL-PDUs.

N201-I: LLC layer parameter (see 3GPP TS 44.064 [6] for clarity).
Defines maximum number of octets available to a SN-DATA PDU for a specific SAPI.

N201-U: LLC layer parameter (see 3GPP TS 44.064 [6] for clarity).
Defines maximum number of octets available to a SN-UNITDATA PDU for a specific SAPI.

N-PDU number: a sequence number assigned to N-PDUs per NSAPI.

NSAPI: for each SN-PDU the NSAPI is an index to the PDP context of the PDP that is using the services provided by the SNDCP layer.

Receive N-PDU number: the value of the N-PDU number expected in the next N-PDU received by an NSAPI using acknowledged peer-to-peer LLC operation.

Recovery state: a state for an NSAPI in which duplicated received N-PDUs shall be detected and discarded. The recovery state only applies to NSAPIs using acknowledged peer-to-peer LLC operation.

SAPI: identifies the Service Access Point that the SN-PDU is using at the LLC layer.

Segment number: a sequence number assigned to SN-UNITDATA PDUs carrying segments of an N-PDU.

Send N-PDU number: the value to be assigned as the N-PDU number to the next N-PDU received from the SNDCP user by an NSAPI using acknowledged peer-to-peer LLC operation.

Send N-PDU number (unacknowledged): the value to be assigned as the N-PDU number to the next N-PDU received from the SNDCP user by an NSAPI using unacknowledged peer-to-peer LLC operation.

SNDCP entity: handles the service functions provided by the SNDCP layer. The SNDCP entity is temporary logical link identity specific.

SNDCP management entity: handles communication with SM sub-layer and controls the operation of the SNDCP entity.

SNDCP user: protocol entity that is using the services provided by the SNDCP layer. PDP entities and control entities, e.g. AT command interpreter, are the SNDCP users at the MS. Relay entity is the SNDCP user at the SGSN.

SNDCP XID block: the collection of SNDCP XID parameters being negotiated. It is transferred by the LL-XID and LL-ESTABLISH primitives between SNDCP and LLC.

3.2 Abbreviations

For the purposes of the present document, the abbreviations given in 3GPP TS 21.905 [1], 3GPP TS 22.060 [2], and 3GPP TS 23.060 [3], and the following apply:

CID	Context Identifier
DCOMP	Identifier of the user data compression algorithm used for the N-PDU
ESP	Encapsulating Security Payload
F	First segment indicator bit
GMM	GPRS Mobility Management
IP	Internet Protocol
LLC	Logical Link Control
LSB	Least Significant Bits
M	More bit used to indicate the last segment of N-PDU
N-PDU	Network Protocol Data Unit
MRRU	Maximum Reconstructed Reception Unit
MSB	Most Significant Bits
NSAPI	Network Layer Service Access Point Identifier
P	Propose bit
PCOMP	Identifier of the protocol control information compression algorithm used for the N-PDU
PDP	Packet Data Protocol (e.g. IPv4 or IPv6)
PDU	Protocol Data Unit
PID	Protocol Identifier
PTP	Point to Point
QoS	Quality of Service
ROHC	RObust Header Compression
RTP	Real Time Protocol
SAPI	Service Access Point Identifier
SDU	Service Data Unit
SGSN	Serving GPRS Support Node
SM	Session Management
SNDCP	Subnetwork Dependent Convergence Protocol
SNSM	SNDCP-SM
TCP	Transmission Control Protocol
TLLI	Temporary Logical Link Identifier
X	Spare bit

4 General

The present document describes the functionality of the GPRS SNDCP. The overall GPRS logical architecture is defined in 3GPP TS 23.060 [3]. Location of the SNDCP in GPRS protocol stack can be seen in figure 1.

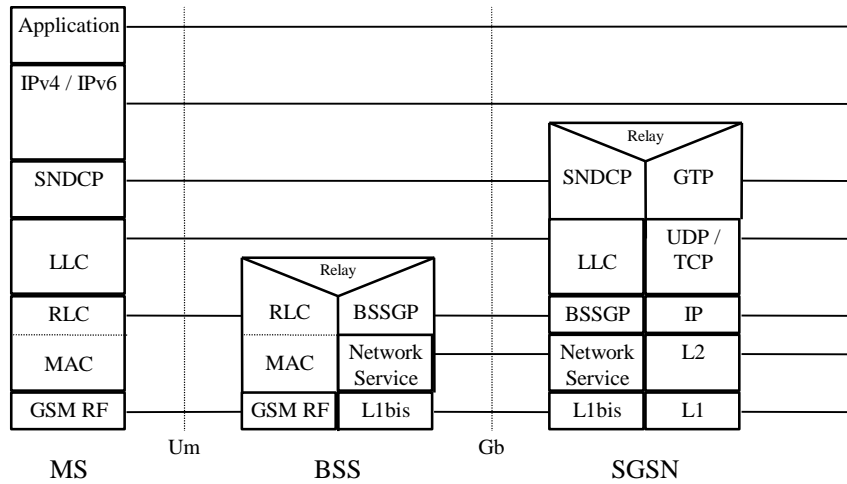

Figure 1: GPRS protocol stack

Network layer protocols are intended to be capable of operating over services derived from a wide variety of subnetworks and data links. GPRS supports several network layer protocols providing protocol transparency for the users of the service. Introduction of new network layer protocols to be transferred over GPRS shall be possible without any changes to GPRS. Therefore, all functions related to transfer of Network layer Protocol Data Units (N-PDUs) shall be carried out in a transparent way by the GPRS network entities. This is one of the requirements for GPRS SNDCP.

Another requirement for the SNDCP is to provide functions that help to improve channel efficiency. This requirement is fulfilled by means of compression techniques.

The set of protocol entities above SNDCP consists of commonly used network protocols. They all use the same SNDCP entity, which then performs multiplexing of data coming from different sources to be sent using the service provided by the LLC layer (figure 2). The Network Service Access Point Identifier (NSAPI) is an index to the PDP context (see 3GPP TS 23.060 [3]) of the PDP that is using the services provided by SNDCP. One PDP may have several PDP contexts and NSAPIs. However, it is possible that each allocated NSAPI is used by separate PDP. Each active NSAPI shall use the services provided by the Service Access Point Identifier (SAPI) in the LLC layer. Several NSAPIs may be associated with the same SAPI.

Since the adaptation of different network layer protocols to SNDCP is implementation dependent, it is not defined in the present document.

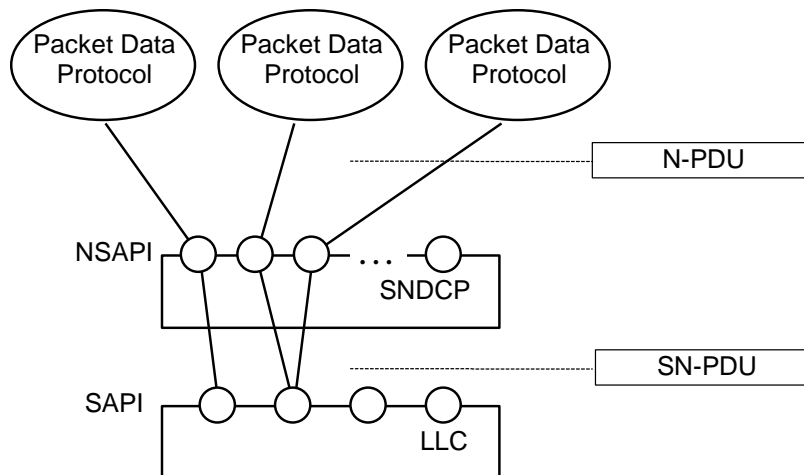

Figure 2: Example for multiplexing of different protocols

5 Service primitives and functions

5.1 Service primitives

This subclause explains the service primitives used for communication between the SNDCP layer and other layers. See also 3GPP TS 24.007 [4] to get an overall picture of the service primitives. Figure 3 illustrates the service access points through which the primitives are carried out.

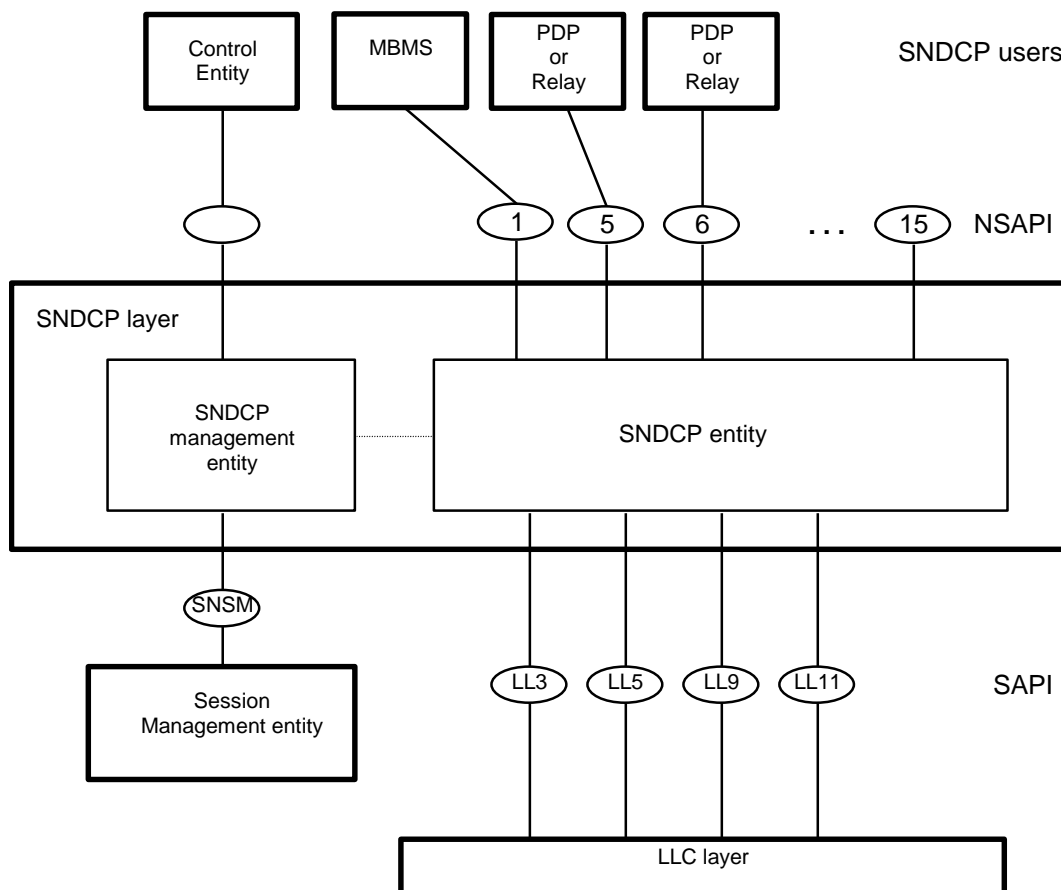

Figure 3: Service Access Points provided and used by SNDCP

5.1.1 SNDCP service primitives

The primitives provided by the SNDCP layer are listed in table 1.

Table 1: SNDCP layer service primitives

Generic Name	Type				Parameters
	Request	Indication	Response	Confirm	
SNDCP User (PDP or the SGSN Relay) ↔ SNDCP					
SN-DATA	X	-	-	-	N-PDU, NSAPI, N-PDU Number
SN-DATA	-	X	-	-	N-PDU, NSAPI
SN-UNITDATA	X	X	-	-	N-PDU, NSAPI
SN-XID	X	X	-	-	Requested SNDCP XID Parameters
SN-XID	-	-	X	X	Negotiated SNDCP XID Parameters

5.1.1.1 SN-DATA.request

Request used by the SNDCP user for acknowledged transmission of N-PDU. The successful transmission of SN-PDU shall be confirmed by the LLC layer. The SN-DATA.request primitive conveys NSAPI to identify the PDP using the service. N-PDU Number, if present, indicates the N-PDU number previously assigned to this N-PDU.

NOTE: An N-PDU number may have been assigned to an N-PDU by the old SGSN before an inter-SGSN routing area update.

5.1.1.2 SN-DATA.indication

Indication used by the SNDCP entity to deliver the received N-PDU to the SNDCP user. Successful reception has been acknowledged by the LLC layer.

5.1.1.3 SN-UNITDATA.request

Request used by the SNDCP user for unacknowledged transmission of N-PDU. The SN-UNITDATA.request primitive conveys NSAPI to identify the PDP using the service.

5.1.1.4 SN-UNITDATA.indication

Indication used by the SNDCP entity to deliver the received N-PDU to the SNDCP user.

5.1.1.5 SN-XID.request

Request used by the SNDCP user at the initiating entity to deliver the list of requested XID parameters to the peer entity.

5.1.1.6 SN-XID.indication

Indication used by the SNDCP entity to deliver the list of requested XID parameters to the SNDCP user.

5.1.1.7 SN-XID.response

Response used by the SNDCP user to deliver the list of negotiated XID parameters to the peer entity.

5.1.1.8 SN-XID.confirm

Confirm used by the SNDCP entity to deliver the list of negotiated XID parameters to the SNDCP user.

5.1.2 Service primitives used by SNDCP layer

The SNDCP layer uses the service primitives provided by the SM sublayer and the LLC layer (see table 2). SM is specified in 3GPP TS 24.008 [5a] and LLC in 3GPP TS 44.064 [6].

Table 2: Service primitives used by the SNDCP entity

Generic Name	Type				Parameters
	Request	Indication	Response	Confirm	
SNDCP ↔ LLC					
LL-RESET	-	X	-	-	TLLI, old XID indicator
LL-ESTABLISH	X	-	-	-	TLLI, XID Requested
LL-ESTABLISH	-	X	-	-	TLLI, XID Requested, N201-I, N201-U
LL-ESTABLISH	-	-	X	-	TLLI, XID Negotiated
LL-ESTABLISH	-	-	-	X	TLLI, XID Negotiated, N201-I, N201-U
LL-RELEASE	X	-	-	-	TLLI, Local
LL-RELEASE	-	X	-	-	TLLI, Cause
LL-RELEASE	-	-	-	X	TLLI
LL-XID	X	-	-	-	TLLI, XID Requested
LL-XID	-	X	-	-	TLLI, XID Requested, N201-I, N201-U
LL-XID	-	-	X	-	TLLI, XID Negotiated
LL-XID	-	-	-	X	TLLI, XID Negotiated, N201-I, N201-U
LL-DATA	X	-	-	-	TLLI, SN-PDU, Reference, QoS Parameters, Radio Priority
LL-DATA	-	X	-	-	TLLI, SN-PDU
LL-DATA	-	-	-	X	TLLI, Reference
LL-UNITDATA	X	-	-	-	TLLI, SN-PDU, QoS Parameters, Radio Priority, Cipher
LL-UNITDATA	-	X	-	-	TLLI, SN-PDU
LL-STATUS	-	X	-	-	TLLI, Cause
SNDCP ↔ SM					
SNSM-ACTIVATE	-	X	-	-	TLLI, NSAPI, QoS profile, SAPI, Radio Priority
SNSM-ACTIVATE	-	-	X	-	TLLI, NSAPI
SNSM-DEACTIVATE	-	X	-	-	TLLI, NSAPI(s), LLC Release Indicator, XID Negotiation Indicator
SNSM-DEACTIVATE	-	-	X	-	TLLI, NSAPI
SNSM-MODIFY	-	X	-	-	TLLI, NSAPI, QoS Profile, SAPI, Radio Priority, Send N-PDU Number, Receive N-PDU Number
SNSM-MODIFY	-	-	X	-	TLLI, NSAPI
SNSM-STATUS	X	-	-	-	TLLI, SAPI, Cause
SNSM-SEQUENCE	-	X	X	-	TLLI, NSAPI, Receive N-PDU Number
SNSM-STOP-ASSIGN	-	X	-	-	TLLI, NSAPI

5.1.2.1 LL-RESET.indication

Indication used by the LLC layer in the SGSN to indicate to the SNDCP layer that the Reset XID parameter has been transmitted, and by the LLC layer in the MS to indicate to the SNDCP layer that the Reset XID parameter has been received.

Upon receipt of the LL-RESET.indication, the SNDCP layer shall:

- treat all outstanding SNDCP ↔ LLC request type primitives as not sent;
- if the old XID indicator is set, keep the SNDCP XID parameters that were applicable before the receipt of the LL-RESET.indication and re-initialize any negotiated compression entities. Otherwise, if the old XID indicator is not set, reset all SNDCP XID parameters to their default values (for the definition of default values see subclause 6.8.2 and clause 8, table 8);

- in the MS, for every NSAPI using unacknowledged peer-to-peer LLC operation, set the Send N-PDU number (unacknowledged) to 0; and
- for every NSAPI using acknowledged peer-to-peer LLC operation, enter the recovery state and suspend the transmission of SN-PDUs until an SNSM-SEQUENCE.indication primitive is received for the NSAPI. In the SGSN the SNDCCP layer shall re-establish acknowledged peer-to-peer operation for the affected SAPIs in the LLC layer.

5.1.2.2 LL-ESTABLISH.request

Request used by the SNDCCP layer to establish or re-establish acknowledged peer-to-peer operation for a SAPI in the LLC layer. `XID Requested` is used to deliver the requested SNDCCP `XID` parameters to the LLC layer.

5.1.2.3 LL-ESTABLISH.indication

Indication used by the LLC layer to inform the SNDCCP layer about establishment or re-establishment of acknowledged peer-to-peer operation for a SAPI in the LLC layer. `XID Requested` is used to deliver the requested SNDCCP `XID` parameters to the SNDCCP layer. In case of a re-establishment, all NSAPIs mapped to the affected SAPI shall enter the recovery state, and all buffered N-PDUs (i.e. the ones whose complete reception has not been acknowledged and the ones that have not been transmitted yet), except the feedback N-PDUs, shall be transmitted starting with the oldest N-PDU when the link is re-established. Also all compression entities using acknowledged peer-to-peer LLC operation on this SAPI are reset.

Before the transmission of N-PDUs is resumed, any feedback N-PDUs shall be removed from the buffered N-PDUs. If feedback N-PDUs are removed, the SNDCCP layer shall reassign the N-PDU numbers of the remaining N-PDUs, so that consecutive numbering is restored and transmission is started with the N-PDU number expected by the peer SNDCCP entity. If the LL-ESTABLISH.indication primitive is used to re-establish acknowledged peer-to-peer LLC operation during an inter-SGSN routing area update, the N-PDU numbers shall be reassigned only after receipt of the SNSM-SEQUENCE.indication.

5.1.2.4 LL-ESTABLISH.response

Response used by the SNDCCP layer after reception of the LL-ESTABLISH.indication. `XID Negotiated` is used to deliver the negotiated SNDCCP `XID` parameters to the LLC layer.

5.1.2.5 LL-ESTABLISH.confirm

Confirmation used by the LLC layer to inform the SNDCCP layer about successful initiation of acknowledged peer-to-peer operation for a SAPI in the LLC layer. `XID Negotiated` is used to deliver the negotiated SNDCCP `XID` parameters to the SNDCCP layer. In case of a re-establishment, all NSAPIs mapped to the affected SAPI shall enter the recovery state, and all buffered N-PDUs (i.e. the ones whose complete reception has not been acknowledged and the ones that have not been transmitted yet), except the feedback N-PDUs, shall be transmitted starting with the oldest N-PDU when the link is re-established. Also all compression entities using acknowledged peer-to-peer LLC operation on this SAPI are reset.

Before the transmission of N-PDUs is resumed, any feedback N-PDUs shall be removed from the buffered N-PDUs. If feedback N-PDUs are removed, the SNDCCP layer shall reassign the N-PDU numbers of the remaining N-PDUs, so that consecutive numbering is restored and transmission is started with the N-PDU number expected by the peer SNDCCP entity. If the LL-ESTABLISH.confirm primitive is used to re-establish acknowledged peer-to-peer LLC operation during an inter-SGSN routing area update, the N-PDU numbers shall be reassigned only after receipt of the SNSM-SEQUENCE.indication.

5.1.2.6 LL-RELEASE.request

Request used by the SNDCCP layer to release acknowledged peer-to-peer operation for a SAPI in the LLC layer. The `Local` parameter indicates whether the termination shall be local (see 3GPP TS 44.064 [6] for details).

5.1.2.7 LL-RELEASE.indication

Indication used by the LLC layer to inform the SNDCCP layer about termination of acknowledged peer-to-peer operation for a SAPI in the LLC layer. The `Cause` parameter indicates the cause for the termination.

On receipt of LL-RELEASE.indication, compressed N-PDUs queuing to be forwarded to the affected SAPI are deleted from the SNDCP layer. Also all compression entities using acknowledged peer-to-peer LLC operation on this SAPI are reset.

5.1.2.8 LL-RELEASE.confirm

Confirmation used by the LLC layer to inform the SNDCP layer about termination of acknowledged peer-to-peer operation for a SAPI in the LLC layer. On receipt of LL-RELEASE.confirm, compressed N-PDUs queuing to be forwarded to the affected SAPI are deleted from the SNDCP layer. Also all compression entities using acknowledged peer-to-peer LLC operation on this SAPI are reset.

5.1.2.9 LL-XID.request

Request used by the SNDCP layer to deliver the requested SNDCP XID parameters to the LLC layer.

5.1.2.10 LL-XID.indication

Indication used by the LLC layer to deliver the requested SNDCP XID parameters to the SNDCP layer.

5.1.2.11 LL-XID.response

Response used by the SNDCP layer to deliver the negotiated SNDCP XID parameters to the LLC layer.

5.1.2.12 LL-XID.confirm

Confirm used by the LLC layer to deliver the negotiated SNDCP XID parameters to the SNDCP layer.

5.1.2.13 LL-DATA.request

Request used by the SNDCP layer for acknowledged transmission of an SN-PDU. The SNDCP entity shall associate a reference parameter for each LL-DATA.request. QoS Parameters in the SGSN includes precedence class, delay class, and peak throughput. QoS Parameters in the MS includes peak throughput. QoS Parameters is defined as part of the Quality of Service information element in 3GPP TS 24.008 [5a]. Radio Priority is included only in the MS, and indicates the radio priority level to be used by RLC/MAC.

Acknowledged peer-to-peer LLC operation for the SAPI used shall be established using the LL-ESTABLISH primitives, before the LL-DATA.request may be used.

5.1.2.14 LL-DATA.indication

Indication used by the LLC layer to deliver the successfully received SN-PDU to the SNDCP layer.

5.1.2.15 LL-DATA.confirm

Confirm used by the LLC layer to inform SNDCP layer about successful transmission of SN-PDU. The primitive includes a reference parameter from which the SNDCP entity shall identify the LL-DATA.request this confirmation was associated with. All buffered N-PDUs whose complete reception is confirmed are deleted.

5.1.2.16 LL-UNITDATA.request

Request used by the SNDCP layer for unacknowledged transmission of a SN-PDU. Unconfirmed transmission shall be used by the LLC layer.

Acknowledged peer-to-peer LLC operation does not need to be established before unacknowledged transmission is allowed.

QoS Parameters in the SGSN includes precedence class, delay class, reliability class, and peak throughput. QoS Parameters in the MS includes peak throughput and reliability class. Reliability class indicates whether the LLC frame carrying the SN-PDU shall be transmitted in protected or unprotected mode, and whether RLC/MAC acknowledged or

unacknowledged mode shall be used. Radio Priority is included only in the MS, and indicates the radio priority level to be used by RLC/MAC.

5.1.2.17 LL-UNITDATA.indication

Indication used by the LLC layer to deliver the received SN-PDU to the SMDCP layer. There is no need for acknowledged peer-to-peer LLC operation for unacknowledged transmission of SN-PDU.

5.1.2.18 LL-STATUS.indication

Indication used by the LLC layer to inform SMDCP when an LLC error that cannot be corrected by the LLC layer has occurred. The Cause parameter indicates the cause of the failure.

On receipt of LL-STATUS.indication, SMDCP shall inform the SM sub-layer by means of the SNSM-STATUS.request primitive.

5.1.2.19 SNSM-ACTIVATE.indication

Indication used by the SM entity to inform the SMDCP entity that an NSAPI has been activated for data transfer. It also informs the SMDCP entity about the negotiated QoS profile (see 3GPP TS 24.008 [5a]), the SAPI assigned for this NSAPI, and, in the MS, the radio priority level to be used by RLC/MAC.

If the NSAPI activated uses the acknowledged peer-to-peer LLC operation, the NSAPI shall enter the recovery state.

Upon reception of the SNSM-ACTIVATE.indication from the SM sublayer, the SMDCP entity shall, if necessary, establish the acknowledged peer-to-peer LLC operation for the indicated SAPI. The establishment criteria and procedure are described in subclause 6.2.1.

5.1.2.20 SNSM-ACTIVATE.response

Response used by the SMDCP layer to inform SM entity that the indicated NSAPI is now in use and that the acknowledged peer-to-peer LLC operation for the indicated SAPI is established, if necessary.

5.1.2.21 SNSM-DEACTIVATE.indication

Indication used by the SM entity to inform the SMDCP entity that an NSAPI has been deallocated and cannot be used by the SMDCP entity anymore. All buffered N-PDUs corresponding to this NSAPI are deleted.

Upon reception of the SNSM-DEACTIVATE.indication, the SMDCP entity shall, if necessary, release the acknowledged peer-to-peer LLC operation for the associated SAPI. The release criteria and procedure are described in subclause 6.2.2. If the XID Negotiation Indicator is included in the SNSM-DEACTIVATE.indication and compression entities have been negotiated for the NSAPI, the NSAPI shall be removed from the Applicable NSAPIs of these compression entities by explicit XID negotiation. If no XID Negotiation Indicator is included, the NSAPI shall be removed locally, without XID negotiation (see subclause 6.8).

5.1.2.22 SNSM-DEACTIVATE.response

Response used by the SMDCP layer to inform SM entity that the NSAPI indicated is no longer in use and that the acknowledged peer-to-peer LLC operation for the associated SAPI is released, if necessary.

5.1.2.23 SNSM-MODIFY.indication

Indication used by the SM entity to trigger change of the QoS profile (see 3GPP TS 24.008 [5a]) for an NSAPI and indication of the SAPI to be used. It is also used by the SM entity in the SGSN to inform the SMDCP entity that an NSAPI shall be created, together with the (re-)negotiated QoS profile, the SAPI assigned, and, in the MS, the radio priority level to be used by RLC/MAC.

NOTE: The latter is performed in the new SGSN during an Inter-SGSN Routing Area Update.

Upon reception of the SNSM-MODIFY.indication from the SM sublayer:

- the SNDCP entity shall, if necessary, establish the acknowledged peer-to-peer LLC operation for the indicated SAPI (the establishment criteria and procedure are described in subclause 6.2.1); and
- the SNDCP entity shall also, if necessary, release the acknowledged peer-to-peer LLC operation for the originally-assigned SAPI (the release criteria and procedure are described in subclause 6.2.2).

If the SNSM-MODIFY.indication applies to an existing NSAPI, and:

- if the peer-to-peer LLC operation mode is changed from acknowledged to unacknowledged, then all buffered N-PDUs shall be deleted, and the Send N-PDU number (unacknowledged) shall be set to 0; and
- if the peer-to-peer LLC operation mode is changed from unacknowledged to acknowledged, then the Send N-PDU number and Receive N-PDU number shall be set to 0.

In addition, if the newly-assigned SAPI is different from the original SAPI:

- LL-DATA.indication, LL-DATA.confirm and LL-UNITDATA.indication received on the old SAPI shall be ignored;
- LL-DATA.request and LL-UNITDATA.request shall be sent on the new SAPI; and
- if acknowledged peer-to-peer LLC operation is used both before and after the receipt of the SNSM-MODIFY.indication, then the NSAPI shall enter the recovery state, and all buffered N-PDUs (i.e. the ones whose complete reception has not been acknowledged and the ones that have not been transmitted yet) shall be transmitted starting from the oldest N-PDU.

If the SNSM-MODIFY.indication signifies the creation of an NSAPI (i.e. the specified NSAPI does not exist), and:

- if unacknowledged peer-to-peer LLC operation is specified in the QoS profile, then the Send N-PDU number (unacknowledged) shall be set to 0; and
- if acknowledged peer-to-peer LLC operation is specified in the QoS profile, then the Send N-PDU number and the Receive N-PDU number variables shall be set to the values stated in the primitive.

5.1.2.24 SNSM-MODIFY.response

Response used by the SNDCP entity to inform the SM entity that the indicated NSAPI and QoS profile are now in use and the acknowledged peer-to-peer LLC operations for the appropriate SAPIs are established and/or released, if necessary.

5.1.2.25 SNSM-STATUS.request

This primitive is used by the SNDCP layer to inform the SM sub-layer that SNDCP cannot continue its operation due to errors at the LLC layer (as indicated with LL-RELEASE.indication) or at the SNDCP layer. The Cause parameter indicates the cause of the error.

5.1.2.26 SNSM-SEQUENCE.indication

This primitive is used during an inter-SGSN routing area update and applies only to NSAPIs using acknowledged peer-to-peer LLC operation. When the primitive is used in the MS, the Receive N-PDU number parameter indicates the Receive N-PDU number in the SGSN. When the primitive is used in the SGSN, the Receive N-PDU number parameter indicates the Receive N-PDU number in the MS. If a buffered N-PDU is confirmed by the Receive N-PDU number parameter to have been received by the peer SNDCP entity, the N-PDU shall be deleted from the buffer. In addition, the receipt of this primitive by the SNDCP entity resumes the transmission of N-PDUs for the NSAPI, and all buffered N-PDUs (i.e. the ones whose complete reception has not been acknowledged and the ones that have not been transmitted yet), except the feedback N-PDUs, shall be transmitted starting from the oldest N-PDU. Before the transmission is resumed, any feedback N-PDUs shall be removed from the buffered N-PDUs. If feedback N-PDUs are removed, the SNDCP layer shall reassign the N-PDU numbers of the remaining N-PDUs, so that consecutive numbering is restored and transmission is started with the N-PDU number expected by the peer SNDCP entity. If acknowledged peer-to-peer LLC operation has not yet been established for the SAPI used by this NSAPI, the

transmission of the buffered N-PDUs shall begin only after the receipt of the LL-ESTABLISH.indication or LL-ESTABLISH.confirm primitive.

5.1.2.27 SNSM-SEQUENCE.response

This primitive is used during an inter-SGSN routing area update and applies only to NSAPIs using acknowledged peer-to-peer LLC operation. The primitive is used by the SNDCP layer in the MS following receipt of an SNSM-SEQUENCE.indication, in order to return the Receive N-PDU number to the SGSN during an ongoing inter-SGSN routing area update.

5.1.2.28 SNSM-STOP-ASSIGN.indication

This primitive is used during an inter-SGSN routing area update in the old SGSN by the SM entity to inform the SNDCP entity to stop assigning N-PDU numbers to N-PDUs received through the SN-DATA.request primitive. The primitive is sent before the Send N-PDU number and the Receive N-PDU number are transferred to the new SGSN.

5.2 Service functions

SNDCP shall perform the following functions (see figure 4):

- Mapping of SN-DATA primitives onto LL-DATA primitives.
- Mapping of SN-UNITDATA primitives onto LL-UNITDATA primitives.
- Multiplexing of N-PDUs from one or several network layer entities onto the appropriate LLC connection.
- Establishment, re-establishment and release of acknowledged peer-to-peer LLC operation.
- Supplementing the LLC layer in maintaining data integrity for acknowledged peer-to-peer LLC operation by buffering and retransmission of N-PDUs.
- Management of delivery sequence for each NSAPI, independently.
- Compression of redundant protocol control information (e.g. TCP/IP header) at the transmitting entity and decompression at the receiving entity. The compression method is specific to the particular network layer or transport layer protocols in use.
- Compression of redundant user data at the transmitting entity and decompression at the receiving entity. Data compression is performed independently for each SAPI, and may be performed independently for each PDP context. Compression parameters are negotiated between the MS and the SGSN.
- Segmentation and reassembly. The output of the compressor functions is segmented to the maximum length of LL-PDU. These procedures are independent of the particular network layer protocol in use.
- Negotiation of the XID parameters between peer SNDCP entities using XID exchange.

Figure 4 shows the transmission flow through SNDCP layer. The order of functions is the following:

- Protocol control information compression.
- User data compression.
- Segmentation of compressed information into SN-DATA or SN-UNITDATA PDUs.

The order of functions is vice versa in the reception flow:

- Reassembly of SN-PDUs to N-PDUs.
- User data decompression.
- Protocol control information decompression.

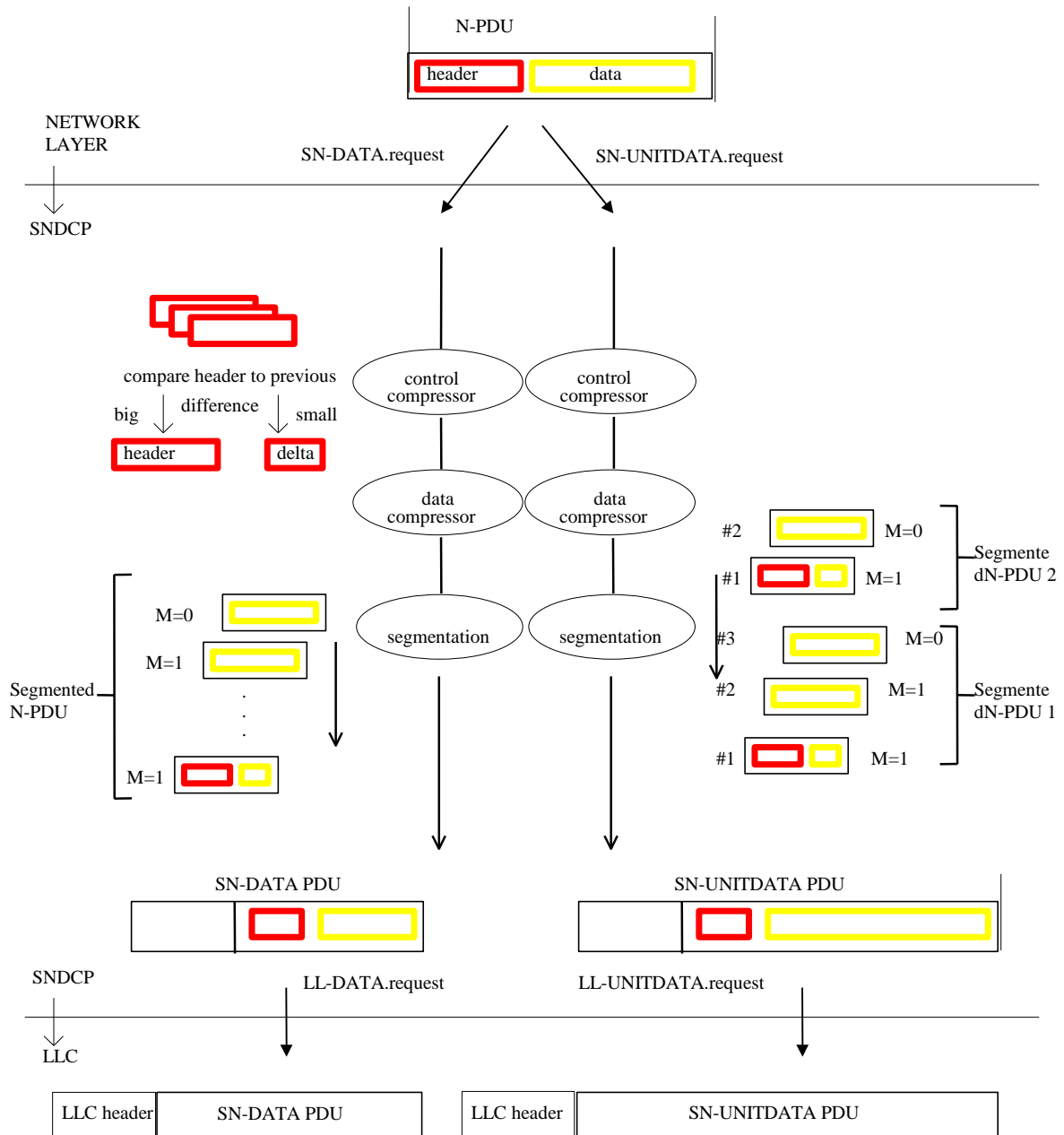

Figure 4: SNDCP model

The SNDCP layer expects the following services to be provided by the LLC layer. LLC layer functionality is defined in 3GPP TS 44.064 [6]:

- Acknowledged and unacknowledged data transfer.
- Point-to-point and point-to-multipoint data transfer.
- In-order delivery of SN-PDUs per SAPI (i.e. SN-PDUs using the same SAPI shall appear at the receiving end in the same order as transmitted). This is required only for acknowledged service.
- QoS profile-based transfer of SN-PDUs.
- Support for variable length SN-PDUs.
- Transfer of SNDCP XID parameters.

The SMDCP layer expects the following services to be provided by the SM sublayer. SM sublayer functionality is defined in 3GPP TS 24.008 [5a]:

- Activation and deactivation of PDP Contexts and informing the SMDCP layer when change in PDP context has happened.
- Carrying out Inter SGSN Routing Area Update and informing the SMDCP layer in the SGSN when the N-PDUs shall be tunnelled to the new SGSN.
- Notifying the SMDCP layer when there is need to change the QoS profile parameters of the PDP contexts.

6 Protocol functions

6.1 Multiplexing of N-PDUs

The NSAPI field shall be used for the identification of the specific PDP type and PDP address pair that is using the services provided by the SMDCP layer. The MS allocates NSAPIs dynamically at the PDP Context Activation. The NSAPI is delivered by the SM sub-layer to the SMDCP layer with the SNSM-ACTIVATE indication primitive. The transmitting SMDCP entity shall insert the NSAPI value for each N-PDU. The peer SMDCP entity uses the NSAPI to identify the SMDCP user the N-PDU is targeted. Table 3 shows an example for the allocation of the NSAPIs.

Table 3: Example of the NSAPI allocation

PDP type	Allocated NSAPI	PDP address
IPv4	12	133.12.75.111 (4 octets)
IPv6	13	133.12.11.123 (16 octets)

6.2 Establishment and release of acknowledged peer-to-peer LLC operation

The SMDCP layer shall be responsible for establishing, re-establishing and releasing the acknowledged peer-to-peer LLC operation.

Re-establishment and release of the acknowledged peer-to-peer LLC operation may also be initiated by the LLC layer. The conditions under which this may happen are described in 3GPP TS 44.064 [6].

Negotiation of SMDCP XID parameters may be carried out in conjunction with the establishment or re-establishment procedure. It is also possible to negotiate SMDCP XID parameters independently from the establishment or re-establishment procedure, by using the LL-XID primitives.

6.2.1 Establishment of acknowledged peer-to-peer LLC operation

6.2.1.1 Establishment criteria

If acknowledged peer-to-peer LLC operation is required by an NSAPI (as indicated by the QoS profile) but is not yet established for the SAPI used by the NSAPI, then the SMDCP layer shall initiate the establishment procedure.

The SMDCP layer at the MS shall initiate the establishment, using the procedure in subclause 6.2.1.3, upon receipt of the SNSM-ACTIVATE indication primitive.

The SMDCP layer at the SGSN shall initiate the establishment upon receipt of the SNSM-MODIFY indication primitive.

6.2.1.2 Re-establishment of the acknowledged peer-to-peer LLC operation

The SNDCP layer may initiate re-establishment of the acknowledged peer-to-peer LLC operation for a SAPI under certain situations, for example when an error is detected by a V.42 bis data compression entity used for acknowledged data transfer.

The LLC layer may also initiate re-establishment of the acknowledged peer-to-peer LLC operation for a SAPI under situations described in 3GPP TS 44.064 [6]. The LLC layer informs the SNDCP layers of link re-establishment using the LL-ESTABLISH.indication primitive. This is shown in figure 5.

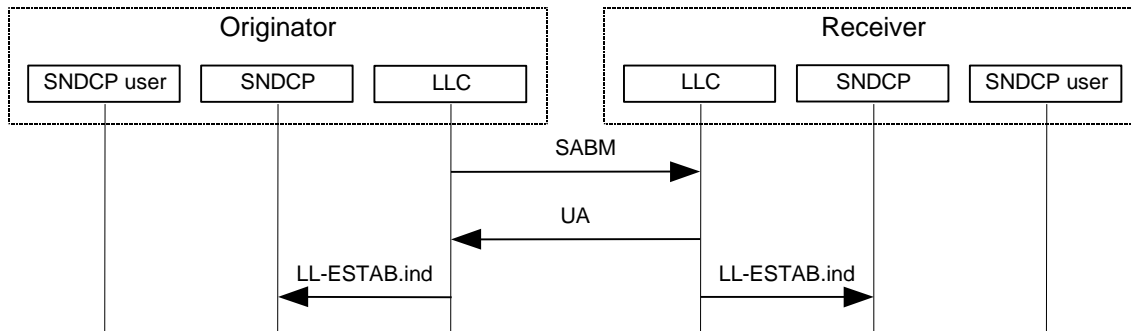

Figure 5: LLC-initiated re-establishment

6.2.1.3 Establishment procedure

The SNDCP layer shall initiate the establishment or re-establishment by sending an LL-ESTABLISH.request primitive to the relevant LLC SAP. SNDCP XID parameters may be included in an SNDCP XID block in the LL-ESTABLISH.request primitive. If no SNDCP XID parameter is to be included, an empty SNDCP XID block shall be included.

Following the sending of the LL-ESTABLISH.request primitive, the SNDCP layer shall suspend the transfer of LL-DATA and may continue the transfer of LL-UNITDATA primitives to the LLC SAP to which the LL-ESTABLISH.request is sent. Transfer of LL-DATA primitives shall be resumed when the establishment procedure has been successfully completed.

The establishment procedure ends through one of the following means:

- successful (receiving LL-ESTABLISH.confirm);
- failure (receiving LL-RELEASE.indication); or
- successful following collision resolution (receiving LL-ESTABLISH.indication and sending LL-ESTABLISH.response, see subclause 6.2.1.4).

Upon receipt of an LL-ESTABLISH.indication primitive, if an SNDCP XID block is present, the peer SNDCP entity shall respond with an LL-ESTABLISH.response primitive. SNDCP XID parameters may be included in an SNDCP XID block in the LL-ESTABLISH.response primitive. If no SNDCP XID parameter is to be included, an empty SNDCP XID block shall be included. If there is no SNDCP XID block in the LL-ESTABLISH.indication primitive, the peer SNDCP entity shall not respond with an LL-ESTABLISH.response primitive.

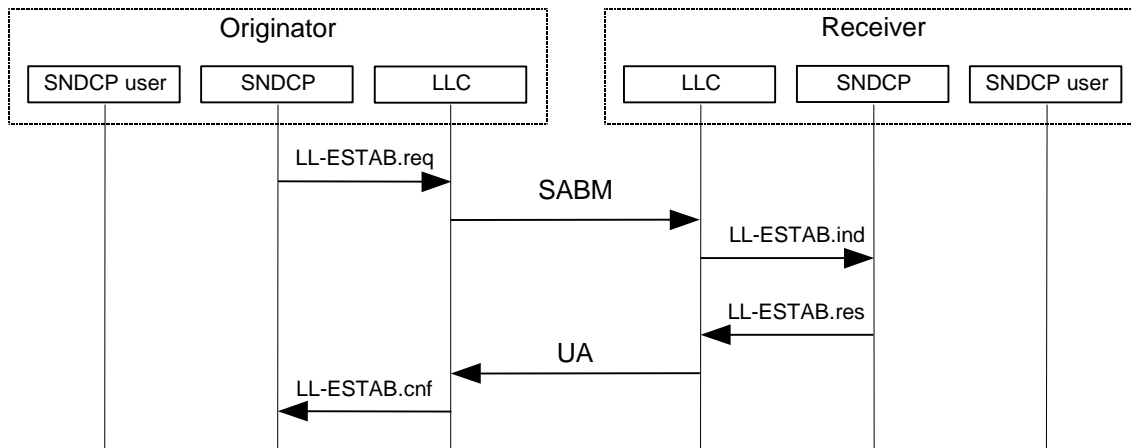

Figure 6: SNDCP-initiated establishment / re-establishment

6.2.1.4 Exceptional situations

If the originator of the establishment procedure receives an LL-RELEASE.indication with Cause "DM received", it shall inform the SM sub-layer using the SNSM-STATUS.request primitive with Cause "DM received". SM shall then deactivate all PDP contexts for that SAPI requiring acknowledged peer-to-peer LLC operation.

If the originator of the establishment procedure receives an LL-RELEASE.indication with Cause "invalid XID response" or an LL-STATUS.indication with Cause "invalid XID response", then it shall inform the SM sub-layer using the SNSM-STATUS.request primitive with Cause "invalid XID response". SM shall then deactivate all PDP contexts for that SAPI.

If the originator of the establishment procedure receives an LL-RELEASE.indication with Cause "no peer response" or an LL-STATUS.indication with Cause "no peer response", then it shall inform the SM sub-layer using the SNSM-STATUS.request primitive with Cause "no peer response", wait for an implementation-specific amount of time, and re-invoke the establishment procedure. Before the establishment procedure is re-invoked, N-PDUs arriving at the SNDCP layer for delivery to the LLC layer shall be buffered, if possible.

If the SNDCP layer receives an LL-RELEASE.indication with Cause "normal release", it shall buffer, if possible, all downlink N-PDUs for NSAPIs using the affected SAPI that requires acknowledged peer-to-peer LLC operation. Transfer of N-PDUs for NSAPIs that do not require acknowledged peer-to-peer LLC operation shall not be affected.

If the originator of the establishment procedure detects a collision (receiving an LL-ESTABLISH.indication primitive after sending an LL-ESTABLISH.request or LL-XID.request primitive, or receiving an LL-XID.indication primitive after sending an LL-XID.request primitive), it shall treat the LL-ESTABLISH.request or LL-XID.request primitive sent as not transmitted, and process the LL-ESTABLISH.indication or LL-XID.indication primitive received. If the LL-ESTABLISH.request or LL-XID.request contains one or more XID parameters, or one or more compression fields in an XID parameter, or one or more parameters in a compression field, that are not negotiated as part of the collision resolution, then negotiation of these XID parameters shall be performed at the earliest opportunity after conclusion of the collision resolution.

6.2.2 Release of acknowledged peer-to-peer LLC operation

6.2.2.1 Release criteria

If acknowledged peer-to-peer LLC operation is established for the SAPI used by a PDP context that is going to be deactivated or mapped to another SAPI, and if there is no other NSAPIs that require acknowledged peer-to-peer LLC operation using the original SAPI, then the SNDCP layer shall initiate the release procedure.

The SNDCP layer shall initiate the release, using the procedure described in subclause 6.2.2.2, upon receipt of the SNSM-DEACTIVATE.indication primitive.

The SNDCP layer at the SGSN shall also initiate the release upon receipt of the SNSM-MODIFY.indication primitive if an existing NSAPI is specified.

6.2.2.2 Release procedure

The SNDCP layer shall initiate the release by sending a LL-RELEASE.request primitive to the relevant LLC SAP. The Local parameter shall be set if the release is the result of receipt of the SNSM-DEACTIVATE.indication primitive, otherwise it shall not be set.

6.2.2.3 Release initiated by the LLC layer

The LLC layer may initiate release of the acknowledged peer-to-peer LLC operation for a SAPI under situations described in 3GPP TS 44.064 [6]. The LLC layer shall inform the SNDCP layers of the release of acknowledged peer-to-peer LLC operation using the LL-RELEASE.indication primitive. SNDCP shall process the LL-RELEASE.indication primitive as described in subclause 6.2.1.4.

6.3 N-PDU buffering

The N-PDUs shall be buffered in the SNDCP layer before they are compressed segmented and transmitted to the LLC layer. The reception of an SNSM-DEACTIVATE.indication shall trigger the deletion of the buffer for the related NSAPI.

For acknowledged data transfer, the SNDCP entity shall buffer an N-PDU until successful reception of all N-PDUs carrying segments of the N-PDU have been confirmed. The confirmation is carried out using the LL-DATA.confirm primitive from the LLC layer or the SNSM-SEQUENCE.indication primitive from the SM layer. Buffered N-PDUs which have been completely received as indicated by the acknowledgements in an LL-DATA.confirm primitive shall be discarded. During the Inter-SGSN RA Update, buffered N-PDUs whose complete reception by the MS has been confirmed in the SNSM-SEQUENCE.indication primitive shall be discarded, as defined in 3GPP TS 29.060 [7] and 3GPP TS 23.060 [3].

For unacknowledged data transfer, the SNDCP shall delete an N-PDU immediately after it has been delivered to the LLC layer.

6.4 Management of delivery sequence

The SNDCP layer shall retain the delivery sequence of N-PDUs of each NSAPI between the peer entities. The delivery sequence of N-PDUs from different NSAPIs may be changed according to the QoS profiles.

6.5 Protocol control information compression

Protocol control information compression is an optional SNDCP feature except for Multimedia Broadcast/Multicast Service (MBMS) where the support of ROHC decompression is mandatory in the MS.

Negotiation of the supported algorithms and their parameters is carried out between MS and SGSN using the SNDCP XID parameters (see clause 8).

For MBMS, where no negotiation is possible, subclause 6.5.1 does not apply. Compression parameters are pre-configured as defined in subclause 6.5.5.

6.5.1 Negotiation of multiple protocol control information compression types

Each SNDCP entity that supports protocol control information compression shall be able to negotiate one or several protocol control information compression entities with the compression field format shown in figure 7. The negotiation shall be carried out using the XID parameter negotiation specified in subclause 6.8. The initiating entity defines a set of requested compression entities, together with the algorithm and parameters for each compression entity. The set of entities and their algorithms and parameters shall be transmitted to the peer entity. The peer entity responds with the set of negotiated entities and their algorithms and parameters. The peer entity shall select the proposed parameter values or other appropriate values for the negotiated entities. If more than one protocol control information compression algorithm for a specific NSAPI is proposed during the XID negotiation then the receiving peer entity shall only choose one algorithm for that NSAPI.

6.5.1.1 Format of the protocol control information compression field

Bit	8	7	6	5	4	3	2	1
Octet 1	P	X	X	Entity number				
Octet 2	X	X	X	Algorithm identifier				
Octet 3	Length=n-3							
Octet 4	PCOMP1				PCOMP2			
...			
Octet x	High-order octet							
...	...							
Octet n	Low-order octet							

NOTE: The two octets x and x+1, if included, contain the "Applicable NAPIs" parameter (see subclause 7.1.3).

Figure 7: Protocol control information compression field format for SNDCCP XID negotiation

6.5.1.1.1 Spare bit (X)

The X bit shall be set to 0 by the transmitting SNDCCP entity and shall be ignored by the receiving SNDCCP entity.

6.5.1.1.2 Propose bit (P)

The P bit shall be set to 1 if a new compression entity is being proposed, otherwise it shall be set to 0. If the P bit is set to 1, then all octets shall be included, otherwise octet 2 and octets 4 to x-1 shall not be included. If the P bit is set to 1, then only enough number of octets shall be included to contain the number of PCOMP values needed by the corresponding compression algorithm (e.g. PCOMP3 and PCOMP4 shall not be included if the number of PCOMP values needed by a compression algorithm is one or two). If an odd number of PCOMP values are used by a compression algorithm, then the last PCOMP value shall be set to 0 in the compression field by the transmitting SNDCCP entity, and it shall be ignored by the receiving SNDCCP entity.

6.5.1.1.3 Entity number

The entity number shall be used to identify a protocol control information compression entity on a SAPI. The entity number shall be assigned using the following rules:

- The entity number shall be an integer from 0 to 31.
- The entity number shall be assigned independently on each of the SAPIs.
- An entity number shall be in one of the three states: unassigned, selected, or assigned.
- When a new compression entity is to be proposed, an unassigned entity number shall become selected. If there is no unassigned entity number left, the compression entity shall not be proposed.
- A selected entity number shall become assigned if the corresponding proposed compression entity is created as a result of the XID negotiation, otherwise it shall become unassigned.
- An assigned entity number shall become unassigned when the corresponding compression entity is deleted as a result of an XID negotiation, or upon the receipt of the LL-RESET indication primitive.
- In the case of a collision (see subclause 6.2.1.4) in which an entity number is currently selected:
 - If the selected entity number is included with the P bit set to 0 in the incoming SNDCCP XID block, then it shall be assumed that the peer SNDCCP entity agreed to the creation of the proposed entity but the response was lost. Therefore the selected entity number shall become assigned, any selected PCOMP and DCOMP values for the algorithm of the entity shall become assigned, and the compression entity shall be created, before the incoming SNDCCP XID block is processed. After the incoming SNDCCP XID block is processed, the compression entity shall be negotiated again if necessary, as defined in subclause 6.2.1.4.

- Otherwise (i.e. if the selected entity number is not included, or is included with the P bit set to 1 in the incoming SNDCP XID block), the selected entity number shall become unassigned, and any selected PCOMP and DCOMP values for the algorithm of the entity shall become unassigned, before the incoming SNDCP XID block, if any, is processed. Following the collision resolution procedure, the originally-proposed compression entity shall be proposed again (i.e. the originally-proposed compression entity shall not be considered created even if the originally-selected entity number is proposed in the incoming SNDCP XID block) by sending the appropriate primitive (LL-ESTABLISH.request or LL-XID.request). The originally-selected entity number, PCOMP and DCOMP values shall be used for the compression entity being re-proposed if they are unassigned, otherwise a new entity number, PCOMP or DCOMP value shall be selected.
- In the case of a collision in which an entity number is currently assigned:
 - If the peer SNDCP entity proposes a new compression entity with the same entity number, then it shall be assumed that the peer SNDCP entity negotiated the deletion of the entity but the response was lost, and the entity number is being reused. Therefore the original compression entity shall be deleted, the entity number shall become unassigned, PCOMP and DCOMP values shall be unassigned if necessary (see subclause 6.5.1.1.5), and then the proposed compression entity shall be responded to as usual.
 - Otherwise (i.e. if the assigned entity number is not included, or is included with the P bit set to 0 in the incoming SNDCP XID block), the usual rules regarding collision handling shall apply.
- In the case of a collision in which a PCOMP or DCOMP value is currently assigned to a compression algorithm:
 - If the peer SNDCP entity proposes a new compression entity with the same PCOMP or DCOMP assigned to a different algorithm, then it shall be assumed that the peer SNDCP entity negotiated the deletion of all entities using the algorithm to which the PCOMP or DCOMP value was assigned, but the response was lost, and the PCOMP or DCOMP value is being reused. Therefore, all compression entities using that algorithm shall be deleted, all corresponding entity numbers shall become unassigned, and all PCOMP or DCOMP values assigned to the algorithm shall become unassigned, and then the proposed compression entity shall be responded to as usual.
 - Otherwise (i.e. if the assigned PCOMP or DCOMP is not included, or is included and assigned to the same algorithm), the usual rules regarding collision handling shall apply.

6.5.1.1.4 Algorithm identifier

Table 4 show the list of protocol control information compression algorithms supported by the SNDCP layer. When new compression algorithms are needed for SNDCP, table 4 shall be updated.

Table 4: List of protocol control information compression algorithms supported by SNDCP

Compression algorithm	Algorithm identifier (Range 0 to 31)
RFC 1144	0
RFC 2507	1
ROHC	2
-	Other values Reserved

6.5.1.1.5 PCOMP

One or more PCOMP values shall be assigned dynamically to a compression algorithm, based on the negotiation of the XID parameters for protocol control information compression. Each of the assigned PCOMP values denotes one compressed frame type of that compression algorithm.

The assignment of the PCOMP values follows the following general rules:

- PCOMP shall be an integer from 0 to 15.
- PCOMP value 0 is reserved permanently for no compression.
- PCOMP shall be assigned independently on each of the SAPIs.

- An assigned PCOMP value applies to all NSAPIs mapped to the same SAPI.
- PCOMP values shall be assigned to compression algorithms, not to compression entities (i.e. the same PCOMP value(s) shall be used by different compression entities on the same SAPI using the same compression algorithm).
- A PCOMP value shall be in one of the three states: unassigned, selected, or assigned.
- When a new compression entity is to be proposed, and if PCOMP values have not yet been assigned to the corresponding compression algorithm, then the appropriate number of unassigned PCOMP values shall be selected. If there is not enough unassigned PCOMP values left, the compression entity shall not be proposed.
- A selected PCOMP value shall become assigned if the corresponding proposed compression entity is created as a result of the XID negotiation, otherwise it shall become unassigned.
- An assigned PCOMP value shall become unassigned when the corresponding compression algorithm is no longer in use by any compression entity, or upon the receipt of the LL-RESET indication primitive.
- In the case of a collision (see subclause 6.2.1.4), the handling of PCOMP values shall be in accordance with subclause 6.5.1.1.3.

While transferring data, the compressed frame type for an N-PDU is conveyed in the PCOMP field of the SNDCP header of the first SN-PDU belonging to the N-PDU. Any successfully negotiated algorithm may be used for compression of an N-PDU.

6.5.1.2 Resetting compression entities following SNDCP XID negotiation

The LL-Establish primitives shall be used for the negotiation of protocol control information compression if:

- one or more parameters, excluding the applicable NSAPIs, of existing compression entities used with acknowledged peer-to-peer LLC operation are changed by the originator of the negotiation; or
- one or more NSAPIs are removed, by the originator of the negotiation, from existing compression entities used with acknowledged peer-to-peer LLC operation, except when all NSAPIs using the compression entity are removed, or when LLC is already in ADM.

Otherwise, either the LL-Establish primitives or the LL-XID primitives may be used.

If the LL-XID primitives are used for XID negotiation, then in addition to restrictions specified elsewhere in the present document, the following parameters of the protocol control information compression entities are non-negotiable by the responding SNDCP entity:

- any parameter of existing compression entities used with acknowledged peer-to-peer LLC operation.

If one or more parameters, other than the applicable NSAPIs, of a compression entity used with unacknowledged peer-to-peer LLC operation are changed, the compression entity shall be reset locally upon completion of the SNDCP XID negotiation.

6.5.1.3 Parameters for compression entities

On negotiating a compression entity, not all the parameters of the entity have to be specified. If a parameter is to be included, all the preceding parameters shall also be specified, and the length field shall be set to the sum of the lengths of all the parameters specified. If any of the parameters is not specified, the rules in subclause 6.8.2 shall apply.

6.5.2 TCP/IP header compression (RFC1144)

The protocol control information compression method is specific for each network layer protocol type. TCP/IP (IPv4) header compression is specified in RFC 1144 [9].

6.5.2.1 Parameters

Table 5 contains the parameters defined for a compression entity using TCP/IP header compression. They may be negotiated during SNDSCP XID negotiation.

Table 5: RFC 1144 TCP/IP header compression parameters

Algorithm Name	Algorithm Identifier	Length	Parameters				
			Parameter Name	Format	Range	Sense of Negotiation	Default Value
RFC 1144	0	0, 2 or 3 if P bit is 0, 1, 3 or 4 if P bit is 1.	Applicable NSAPIs	bbbbbbbbb bbb00000	0, 32, 64, ..., 65504	down (each bit separately)	0
			S ₀ - 1	bbbbbbbbb	0 through 255	down	15

6.5.2.1.1 Applicable NSAPIs

See subclause 7.1.3.

6.5.2.1.2 S₀

The number of state slots, as defined in [9]. The S₀ range is 1 through 256, with 16 as default value.

6.5.2.2 Assignment of PCOMP values

The underlying service shall be able to distinguish the three types of compressed N-PDUs (i.e. Type IP, Uncompressed TCP, and Compressed TCP), as defined in RFC 1144 [9]. These three N-PDU types are differentiated by using different PCOMP values.

Two PCOMP values shall be assigned to the TCP/IP header compression algorithm. PCOMP1 shall contain the PCOMP value for the frame type "Uncompressed TCP", and PCOMP2 shall contain the PCOMP value for the frame type "Compressed TCP".

The PCOMP value of 0 shall be used for the frame type "Type IP".

6.5.2.3 Error Recovery

When TCP/IP header compression is used with unacknowledged peer-to-peer LLC operation, the decompression entity shall be notified in case an N-PDU is dropped, so that error recovery procedure (see RFC 1144 [9]) can be invoked.

6.5.3 TCP/IP and UDP/IP header compression (RFC 2507)

Detailed operation of the RFC 2507 header compression for IPv4 and IPv6 is described in clause 3 of the IETF specification RFC 2507 [10].

6.5.3.1 Parameters

Table 6 contains the parameters defined for a compression entity using RFC2507 header compression. They may be negotiated during SNDSCP XID negotiation.

Table 6: RFC 2507 TCP/IP and UDP/IP header compression parameters

Algorithm Name	Algorithm Identifier	Length	Parameters				
			Parameter Name	Format	Range	Sense of Negotiation	Default Value
RFC 2507	1	0, 2, 4, 5, 6, 7 or 9 if P bit is 0, 3, 5, 7, 8, 9, 10 or 12 if P bit is 1.	Applicable NSAPIs	bbbbbbbbb bbb00000	0, 32, 64, ... , 65504	down (each bit separately)	0
			F_MAX_PERRIOD	bbbbbbbbb bbbbbbbbb	1-65535	down	256
			F_MAX_TIME	bbbbbbbbb	1-255	down	5
			MAX_HEADER	bbbbbbbbb	60-255	down	168
			TCP_SPACE	bbbbbbbbb	3-255	down	15
			NON_TCP_SPACE	bbbbbbbbb bbbbbbbbb	3-65535	down	15

The explanation of the individual parameters can be found in the clause 14 of the IETF specification RFC 2507 [10].

6.5.3.1.1 Applicable NSAPIs

See subclause 7.1.3.

6.5.3.2 Assignment of PCOMP values for RFC2507

The following PCOMP values shall be assigned to the RFC 2507 header compression. The PCOMP value 0 shall be used for regular IPv4 and IPv6 packets.

Table 7: PCOMP values assigned to RFC 2507 header compression algorithm

PID value	Packet type
PCOMP1	Full header
PCOMP2	Compressed TCP
PCOMP3	Compressed TCP non-delta
PCOMP4	Compressed non-TCP
PCOMP5	Context state

6.5.3.3 Error Recovery

The mechanisms related to error recovery and packet reordering are described in clauses 10 and 11 of the RFC 2507[10].

6.5.4 Robust Header Compression (ROHC)

Robust Header Compression (ROHC) is a framework for header compression, on top of which compression schemes can be defined for the compression of various protocol headers. Both the SNDSCP ROHC negotiation mechanisms and the SN-PDU ROHC identifiers are generally defined for the ROHC framework, and therefore capable of handling both existing and future ROHC compression protocols (profiles). RFC 3095 [12] defines the ROHC framework, as well as the compression schemes and profiles for RTP/UDP/IP, UDP/IP, ESP/IP and uncompressed.

6.5.4.1 Parameters

Table 10 contains the parameters defined for a compression entity using ROHC. They may be negotiated during SNDCCP XID negotiation.

Table 10: Robust Header Compression (ROHC) parameters

Algorithm Name	Algorithm Identifier	Length	Parameters				
			Parameter Name	Format	Range	Sense of Negotiation	Default Value
ROHC	2	0, 2, 4, 6, 8, 8+n*2 if P bit is 0, 1, 3, 5, 7, 9, 9+n*2 if P bit is 1. (where n is the number of profiles, the max. number of profiles is 16)	Applicable NSAPIs	bbbbbbbbb bbb00000	0, 32, 64, ... , 65504	down (each bit separately)	0
			MAX_CID	00bbbbbbb bbbbbbbbb	0-16383	down	15
			MAX_HEADER	00000000 bbbbbbbbb	60-255	down	168
			PROFILE 1	bbbbbbbbb bbbbbbbbb	0-65535	(see 6.5.4.1.5)	0
			PROFILE 2	bbbbbbbbb bbbbbbbbb	0-65535	(see 6.5.4.1.5)	0
		
			PROFILE 16	bbbbbbbbb bbbbbbbbb	0-65535	(see 6.5.4.1.5)	0
NOTE: ROHC parameter MRRU is not negotiated and shall be set to 0, i.e. ROHC segmentation shall not be used.							

6.5.4.1.1 Applicable NSAPIs

See subclause 7.1.3.

6.5.4.1.2 MAX_CID

The MAX_CID parameter indicates the maximum context ID number the compressor is allowed to use. A MAX_CID value of N means CID values of 0 through N are valid. Thus, the number of contexts allowed is N+1, e.g. MAX_CID of 15 means 16 contexts are allowed.

6.5.4.1.3 MAX_HEADER

The MAX_HEADER parameter indicates the maximum number of octets of the protocol control information that may be compressed.

NOTE: The MAX_HEADER parameter is neither defined nor used by RTP/UDP/IP, UDP/IP, ESP/IP and uncompressed profiles as defined in RFC 3095 [12]. For those profiles, this parameter is not used by SNDCCP when performing Robust Header Compression (ROHC).

6.5.4.1.4 (Void)

6.5.4.1.5 PROFILE

The PROFILE parameter indicates the profile identifier. A list of up to 16 PROFILES, indicating which ROHC profiles [14] are supported may be included. The negotiated list which is used for compression consists of the list of profiles supported by both peer entities, reduced to include at most ONE profile identifier with the same 8-bit LSB part. If both peer entities support more than one profile with the same 8-bit LSB part in its profile identifier, the set of these profiles shall be reduced to the profile with the highest MSB-value in its profile identifier.

Note: The reason for this is that the 8-bit MSB part of the profile identifier indicates the "variant" of the profile, and since only the 8-bit LSB part is sent in compressed headers, the set of available profiles must not include two profiles with the same 8-bit LSB part of the profile identifier.

6.5.4.2 Assignment of PCOMP values for ROHC

As opposed to other header compression schemes, the whole ROHC framework has only one packet type that has to be identified by the PDU format, and this packet type can be used by any ROHC compression profile. However, ROHC has two different context identification (CID) sizes. To avoid having to negotiate and potentially re-negotiate CID size, the mechanism from ROHC-over-PPP [13] is adopted in SNDSCP, i.e. as shown in table 9, two packet types are defined for ROHC, one for small and one for large CIDs.

This implies that all CIDs within one ROHC packet shall be of the same size as indicated by the PID value, either small or large. In particular, embedded feedback shall have a CID of the same size as indicated by the PID value. For piggybacking feedback, a compressor must be able to control the feedback CID size used by the associated decompressor, ensure that all CIDs are of the same size, and indicate this size with the appropriate PID value.

Table 9: PCOMP values assigned to Robust Header Compression (ROHC)

PID value	Packet type
PCOMP1	ROHC small-CIDs
PCOMP2	ROHC large-CIDs

6.5.4.3 Error Recovery and other feedback

ROHC has built-in robustness mechanisms to avoid error events, as well as error recovery mechanisms using decompressor to compressor feedback. Such ROHC feedback is carried according to alternative 6) in section 5.2.1 of RFC 3095 [12].

6.5.5 Pre-defined Protocol control information ROHC compression types for MBMS

An SGSN supporting compression for MBMS shall not negotiate compression information with the MSes. An MS which is capable of MBMS shall support pre-defined compression types and associated configuration information.

An SNDSCP entity performing Robust Header Compression (ROHC) for MBMS data traffic shall use the following parameter values:

- Only Unidirectional mode (U-mode) as defined in RFC 3095 [12] shall be used.
- Only profiles for RTP/UDP/IP, UDP/IP and uncompressed as specified in RFC 3095 [12] shall be used.
- Applicable NSAPI = 1.
- MAX_CID set to 511 (i.e. 512 contexts are allowed). The MS shall handle CIDs in the value range of 0 to 511 as used by the SGSN. However, the maximum number of ROHC decompressor contexts the MS simultaneously supports is implementation specific.

The SNDSCP PCOMP values assigned to ROHC for MBMS are preconfigured to PCOMP = 0 which indicates that header compression is not used, PCOMP = 1: ROHC small-CIDs, and PCOMP = 2: ROHC large-CIDs.

MAX_CID, and PCOMP parameters are described in subclauses 6.5.4.1.2 and 6.5.4.2, respectively.

If decompression fails, e.g. due to a cell change, the MS shall reconfigure and re-initialise the SNDSCP entity, reusing the static part of the header decompressor context previously used. Also, after receiving an IR-DYN or IR packet (see RFC 3095 [12]), the MS shall re-initialise header decompression.

The compressor entity in the SGSN shall periodically transit to lower compression states in order for the decompressor entities in the MSes to synchronise with the compressor. For further details about this mechanism, please refer to RFC 3095 [12].

6.6 Data compression

Data compression is an optional SMDCP feature. Data compression applies to both SN-DATA and SN-UNITDATA primitives.

Data compression, if used, shall be performed on the entire N-PDU, including the possibly compressed protocol control information.

Figure 8 shows an example how the SMDCP functions may be used. Several NSAPIs may use a common data compression entity, i.e. the same compression algorithm and the same dictionary. Separate data compression entities shall be used for acknowledged (SN-DATA) and unacknowledged (SN-UNITDATA) data transfer. Several NSAPIs may be associated with one SAPI, i.e. they may use the same QoS profile.

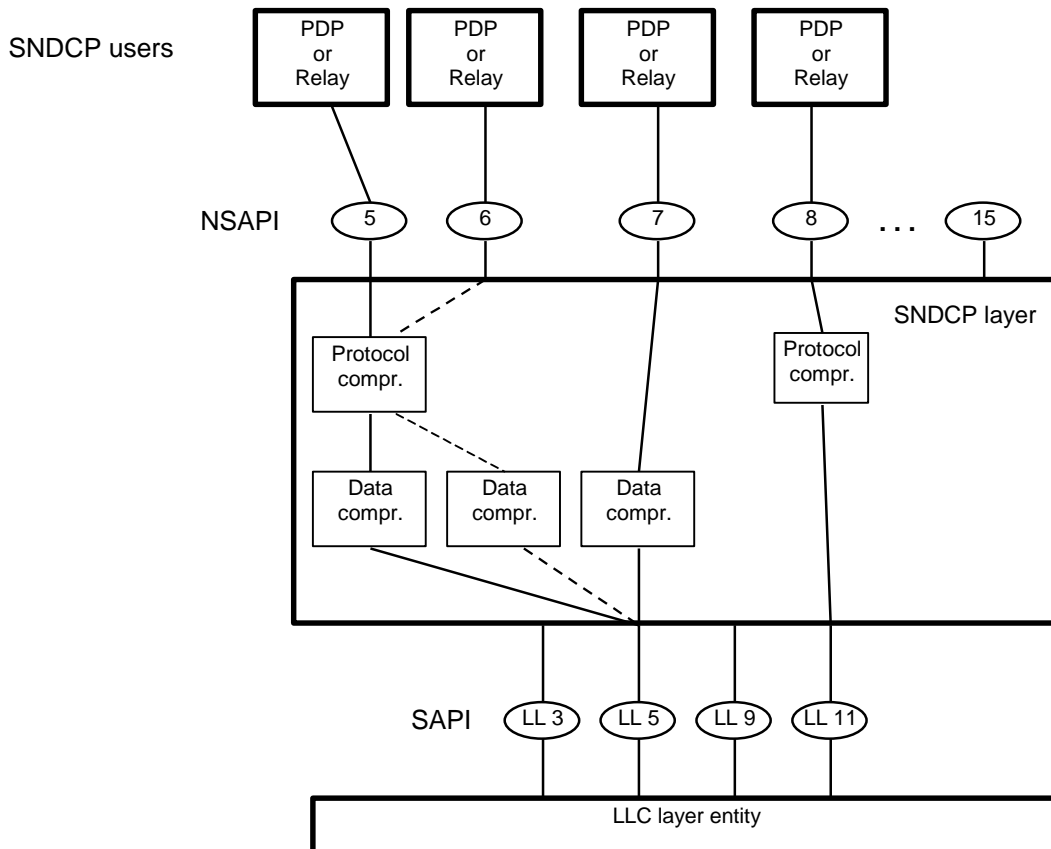

Figure 8: An example for the usage of NSAPIs, SMDCP functions, and SAPIs

6.6.1 Negotiation of multiple data compression types

Each SMDCP entity that supports data compression shall be able to negotiate one or several data compression entities with the compression field format shown in figure 9. The negotiation shall be carried out using the XID parameter negotiation specified in subclause 6.8. The initiating entity defines a set of requested compression entities, together with the algorithm and parameters for each compression entity. The set of entities and their algorithms and parameters shall be transmitted to the peer entity. The peer entity responds with the set of negotiated entities and their algorithms and parameters. The peer entity shall select the proposed parameter values or other appropriate values for the negotiated entities. If more than one data compression algorithm for a specific NSAPI is proposed during the XID negotiation then the receiving peer entity shall only choose one algorithm for that NSAPI.

6.6.1.1 Format of the data compression field

Bit	8	7	6	5	4	3	2	1
Octet 1	P	X	X	Entity number				
Octet 2	X	X	X	Algorithm identifier				
Octet 3	Length=n-3							
Octet 4	DCOMP1				DCOMP2			
...			
Octet x	High-order octet							
...	...							
Octet n	Low-order octet							

NOTE: The two octets x and x+1, if included, contain the "Applicable NAPIs" parameter (see subclause 7.1.3).

Figure 9: Data compression field format for SND CP XID negotiation

6.6.1.1.1 Spare bit (X)

The X bit shall be set to 0 by the transmitting SND CP entity and shall be ignored by the receiving SND CP entity.

6.6.1.1.2 Propose bit (P)

The P bit shall be set to 1 if a new compression entity is being proposed, otherwise it shall be set to 0. If the P bit is set to 1, then all octets shall be included, otherwise octet 2 and octets 4 to x-1 shall not be included. If the P bit is set to 1, then only enough number of octets shall be included to contain the number of DCOMP values needed by the corresponding compression algorithm (e.g. DCOMP3 and DCOMP4 shall not be included if the number of DCOMP values needed by a compression algorithm is one or two). If an odd number of DCOMP values are used by a compression algorithm, then the last DCOMP value shall be set to 0 in the compression field by the transmitting SND CP entity, and it shall be ignored by the receiving SND CP entity.

6.6.1.1.3 Entity number

The entity number shall be used to identify a data compression entity on a SAPI. See subclause 6.5.1.1.3 for the rules for assigning entity numbers. The assignment of entity numbers for protocol control information compression entities and data compression entities shall be independent.

6.6.1.1.4 Algorithm identifier

Table 6a shows the list of data compression algorithms supported by the SND CP layer. When new compression algorithms are needed for SND CP, table 6a shall be updated.

Table 6a: List of data compression algorithms supported by SND CP

Data compression algorithm	Algorithm identifier (Range 0-31)
V.42 bis	0
V.44	1
-	Other values Reserved

6.6.1.1.5 DCOMP

One or more DCOMP values shall be assigned dynamically to a compression algorithm, based on the negotiation of the XID parameters for data compression. Each of the assigned DCOMP values denotes one compressed frame type of that compression algorithm.

The assignment of the DCOMP values shall follow the rules for the assignment of PCOMP values in subclause 6.5.1.1.5.

While transferring data, the compressed frame type for an N-PDU is conveyed in the DCOMP field of the SNDCP header of the first SN-PDU belonging to the N-PDU. Any successfully negotiated algorithm may be used for compression of an N-PDU.

6.6.1.2 Resetting compression entities following SNDCP XID negotiation

The LL-Establish primitives shall be used for the negotiation of data compression if:

- one or more parameters, excluding the applicable NSAPIs, of existing compression entities used with acknowledged peer-to-peer LLC operation are changed by the originator of the negotiation; or
- one or more NSAPIs are removed, by the originator of the negotiation, from existing compression entities used with acknowledged peer-to-peer LLC operation, except when all NSAPIs using the compression entity are removed, or when LLC is already in ADM.

Otherwise, either the LL-Establish primitives or the LL-XID primitives may be used.

If the LL-XID primitives are used for XID negotiation, then in addition to restrictions specified elsewhere in the present document, the following parameters of the data compression entities are non-negotiable by the responding SNDCP entity:

- any parameter of existing compression entities used with acknowledged peer-to-peer LLC operation.

If one or more parameters, other than the applicable NSAPIs, of a compression entity used with unacknowledged peer-to-peer LLC operation are changed, the compression entity shall be reset locally upon completion of the SNDCP XID negotiation.

6.6.1.3 Parameters for compression entities

On negotiating a compression entity, not all the parameters of the entity have to be specified. If a parameter is to be included, all the preceding parameters shall also be specified, and the length field shall be set to the sum of the lengths of all the parameters specified. If any of the parameters is not specified, the rules in subclause 6.8.2 shall apply.

6.6.2 Management of V.42 bis data compression

ITU-T Recommendation V.42 bis [8] data compression may be used with SN-DATA primitives and SN-UNITDATA primitives.

6.6.2.1 Parameters

Table 7a contains the parameters defined for a compression entity using ITU-T Recommendation V.42 bis data compression. They may be negotiated during SNDCP XID negotiation.

Table 7a: V.42 bis data compression parameters

Algorithm Name	Algorithm Identifier	Length	Parameters				
			Parameter Name	Format	Range	Sense of Negotiation	Default Value
V.42 bis	0	0, 2, 3, 5, or 6 if P bit is 0, 1, 3, 4, 6, or 7 if P bit is 1.	Applicable NSAPIs	bbbbbbbbb bbb00000	0, 32, 64, ... , 65504	down (each bit separately)	0
			P ₀	000000bb	0 through 3	down (each direction separately)	3
			P ₁	bbbbbbbbb bbbbbbbbb	512 through 65535	down	2048
			P ₂	bbbbbbbbb	6 through 250	down	20

6.6.2.1.1 Applicable NSAPIs

See subclause 7.1.3.

6.6.2.1.2 P_0

Two bits are used to indicate the usage of compression, one bit for each direction.

00 compress neither direction.

01 compress MS-to-SGSN direction only.

10 compress SGSN-to-MS direction only.

11 compress both directions.

6.6.2.1.3 P_1

Maximum number of codewords in the compressor dictionary (see [8]).

6.6.2.1.4 P_2

Maximum number of characters in an uncompressed data string that is accepted to be encoded.

6.6.2.2 Assignment of DCOMP values

One DCOMP value shall be assigned (as DCOMP1) to the V.42 bis data compression algorithm.

6.6.2.3 Operation of V.42 bis data compression

When V.42 bis is used with SN-DATA primitives, the data in the compression entity shall be flushed (using the C-FLUSH primitive defined in [8]) and added to the compressed N-PDU before the compressed N-PDU is sent.

When V.42 bis is used with SN-UNITDATA primitives, the compression entity shall be reset (using the C-INIT primitive defined in [8]) before an N-PDU is compressed or decompressed. After compression, the data in the compression entity shall be flushed (using the C-FLUSH primitive defined in [8]) and added to the compressed N-PDU before the compressed N-PDU is sent. The LLC protocol shall operate in the protected mode of operation.

When V.42 bis is used with SN-DATA primitives and an error is detected by the decoder, the SNDCCP entity shall use LL-ESTABLISH.request primitive to reset the acknowledged peer-to-peer LLC operation for the SAPI used.

6.6.3 Management of V.44 data compression

ITU-T Recommendation V.44 data compression, as described in [11], may be used with SN-DATA primitives and SN-UNITDATA primitives. Annex B of ITU-T Recommendation V.44 describes two methods of implementation and operation of V.44 in packet networks: Packet Method and Multi-Packet Method. Multi-Packet Method is a superset of Packet Method and an MS or SGSN that supports Multi-Packet Method must also support Packet Method.

6.6.3.1 Parameters

Table 7c contains the parameters defined for a compression entity using V.44 data compression. They may be negotiated during SNDCCP XID negotiation. During V.44 data compression negotiation, unless both the MS and SGSN support Multi-Packet Method, Packet Method is used. Parameter C_0 indicates support of Packet Method (10000000) or both methods (11000000).

NOTE 1: V.44 data compression negotiation is not required. If V.44 is selected and no compression parameters are specified, then Packet Method with defaults as defined in subclauses 6.6.3.1.4 and 6.6.3.1.5 and in [11] annex B, clause B.1.2, is used.

Table 7c: V.44 data compression parameters

Algorithm Name	Algorithm Identifier	Length	Parameters				
			Parameter Name	Format	Range	Sense of Negotiation	Default Value
V.44	1	0, 2, 3, 4, 6, 8, 10, or 12 if P bit is 0, 1, 3, 4, 5, 7, 9, 11, or 13 if P bit is 1	Applicable NSAPIs	bbbbbbbbb bbb00000	0, 32, 64, ... , 65504	down (each bit separately)	0
			C_0	bb000000	10000000 or 11000000	11000000 down to 10000000	10000000
			P_0	000000bb	0 through 3	down (each direction separately)	3
			P_{1T}	bbbbbbbbb bbbbbbbbb	256 through 65535	down	Refer to subclause 6.6.3.1.4
			P_{1R}	bbbbbbbbb bbbbbbbbb	256 through 65535	down	Refer to subclause 6.6.3.1.5
			P_{3T}	bbbbbbbbb bbbbbbbbb	$\geq (2 \times P_{1T})$	down	$3 \times P_{1T}$
			P_{3R}	bbbbbbbbb bbbbbbbbb	$\geq (2 \times P_{1R})$	down	$3 \times P_{1R}$

NOTE 2: V.44 parameters P_{2T} and P_{2R} are set to 255 and not negotiated in packet networks.

6.6.3.1.1 Applicable NSAPIs

See subclause 7.1.3.

6.6.3.1.2 C_0

Two bits are used to indicate the V.44 method of operation supported (refer to [11] Annex B).

10 Packet Method supported.

11 Packet Method and Multi-Packet Method supported.

If parameter C_0 is not specified then Packet Method is selected with its default parameter values (refer to subclauses 6.6.3.1.4 and 6.6.3.1.5 and in [11] annex B, clause B.1.2).

6.6.3.1.3 P_0

Two bits are used to indicate the usage of compression, one bit for each direction.

00 compress neither direction.

01 compress MS-to-SGSN direction only.

10 compress SGSN-to-MS direction only.

11 compress both directions.

6.6.3.1.4 P_{1T}

Maximum number of codewords for the transmit direction (i.e. in the encoder dictionary). Refer to ITU-T Recommendation V.44 [11].

The Packet Method default is 1 600 codewords.

The Multi-Packet Method default is 2 048 codewords.

NOTE: Both defaults above are different from the defaults specified in ITU-T Recommendation V.44 [11] annex B. This is partially due to the fact that data compression in SNDCP includes the control header as well as the information field.

6.6.3.1.5 P_{1R}

Maximum number of codewords for the receive direction (i.e. in the decoder dictionary). Refer to [11].

The Packet Method default is 1 600 codewords.

The Multi-Packet Method default is 2 048 codewords.

NOTE: Both defaults above are different from the defaults specified in ITU-T Recommendation V.44 [11] annex B. This is partially due to the fact that data compression in SNDCP includes the control header as well as the information field.

6.6.3.1.6 P_{3T}

Number of characters in the history for the transmit direction. Refer to [11].

This parameter is not used in Packet Method.

6.6.3.1.7 P_{3R}

Number of characters in the history for the receive direction. Refer to [11].

This parameter is not used in Packet Method.

6.6.3.2 Assignment of DCOMP values

The underlying service shall be able to distinguish three types of N-PDUs processed by V.44 data compression (i.e. not V.44 compressed, V.44 Packet Method compressed, and V.44 Multi-Packet Method compressed). These three V.44 processed N-PDU types are differentiated by using different DCOMP values.

Two DCOMP values shall be assigned to the V.44 compression algorithm, the smaller one of which for Packet Method compressed, and the larger one for Multi-Packet Method compressed.

The DCOMP value of 0 shall be used for SN-PDUs belonging to N-PDUs that expanded during V.44 compression and are sent in their original form (i.e. not V.44 compressed).

6.6.3.3 Operation of V.44 data compression

V.44 data compression has two possible methods of operation in SNDCP, Packet Method and Multi-Packet Method.

6.6.3.3.1 Packet Method

Refer to [11] annex B, clause B.1, for a general description of the operation of V.44 packet method.

When V.44 Packet Method is used with SN-DATA primitives:

- the data in the compression entity shall be flushed (using the C-FLUSH primitive defined in [11]) after the last character of an N-PDU is passed to the encoder.
- If the length of the N-PDU after compression is greater or equal to the length of the original N-PDU, the original N-PDU is sent and the DCOMP field in the SN-PDU header of the first segment of the N-PDU is set to 0, not V.44 compressed.
- In between processing of N-PDU, the dictionary shall be re-initialised as defined in [11].
- If an error is detected by the decoder, the SNDCP entity shall use LL-ESTABLISH.request primitive to reset the acknowledged peer-to-peer LLC operation for the SAPI used.

When V.44 Packet Method is used with SN-UNITDATA primitives:

- the data in the compression entity shall be flushed (using the C-FLUSH primitive defined in [11]) after the last character of an N-PDU is passed to the encoder.
- If the length of the N-PDU after compression is greater or equal to the length of the original N-PDU, the original N-PDU is sent and the DCOMP field in the SN-PDU header of the first segment of the N-PDU is set to 0, not V.44 compressed.
- After an N-PDU is sent, the dictionary shall be re-initialised as defined in [11].
- The LLC protocol shall operate in the protected mode of operation.

6.6.3.3.2 Multi-Packet Method

Refer to [11] annex B, clause B.2, for a general description of the operation of V.44 multi-packet method.

When V.44 Multi-Packet Method is used with SN-DATA primitive:

- the data in the compression entity shall be flushed (using the C-FLUSH primitive defined in [11]) after the last character of an N-PDU is passed to the encoder.
- If the length of the N-PDU after compression is greater than the length of the original N-PDU, the original N-PDU is sent and the DCOMP field in the SN-PDU header of the first segment of the N-PDU is set to 0, not V.44 compressed.
- In the case above of not V.44 compressed where the original N-PDU is sent, after the N-PDU is sent the encoder dictionary shall be re-initialised as defined in [11]. The peer entity, upon receipt of an N-PDU with the DCOMP field set to 0, not V.44 compressed, shall re-initialise its decoder dictionary.
- If an error is detected by the decoder, the SNDCCP entity shall use LL-ESTABLISH.request primitive to reset the acknowledged peer-to-peer LLC operation for the SAPI used.

When V.44 Multi-Packet Method is used with SN-UNITDATA primitives:

- the data in the compression entity shall be flushed (using the C-FLUSH primitive defined in [11]) after the last character of an N-PDU is passed to the encoder.
- After an N-PDU is sent the dictionary shall be re-initialised as defined in [11].
- If the length of the N-PDU after compression is greater or equal to the length of the original N-PDU, the original N-PDU is sent and the DCOMP field in the SN-PDU header of the first segment of the N-PDU is set to 0, not V.44 compressed.
- The LLC protocol shall operate in the protected mode of operation.

6.7 Segmentation and reassembly

Segmentation shall be performed by the SNDCCP entity to ensure that any SN-PDU transmitted is no longer than N201 (see 3GPP TS 44.064 [6]). The receiving SNDCCP entity shall reassemble the segments back to the original (possibly compressed) N-PDU.

The segmentation and reassembly procedures are different for acknowledged and unacknowledged mode of operation.

6.7.1 General

6.7.1.1 Segmentation

A (possibly compressed) N-PDU shall be segmented into one or more SN-PDUs. The length of each SN-PDU shall not be greater than N201-I (for acknowledged mode) or N201-U (for unacknowledged mode).

The F bit in the SNDCCP header shall be set to 1 for the first segment, and 0 for all subsequent segments.

For unacknowledged peer-to-peer LLC operation, DCOMP and PCOMP shall be included in the header when the F bit is set to 1, and shall not be included when the F bit is set to 0.

For acknowledged peer-to-peer LLC operation, DCOMP, PCOMP and N-PDU number shall be included in the header when the F bit is set to 1, and shall not be included when the F bit is set to 0.

If an SN-PDU is received with the F bit set to 1 when a non-first segment is expected, and if DCOMP, PCOMP and (in the acknowledged mode) the N-PDU number all remain unchanged comparing to the first segment, then the SN-PDU shall be processed as normal.

The M bit in the SNDTCP header shall be set to 0 for the last segment, and 1 for all previous segments.

If only one SN-PDU is generated for an N-PDU, the F bit shall be set to 1 and the M bit set to 0.

6.7.1.2 Reassembly

During reassembly, DCOMP and PCOMP for an N-PDU shall be retrieved from the first segment (F bit set to 1). For acknowledged peer-to-peer LLC operation, the N-PDU number shall also be retrieved from the first segment.

The receiving SNDTCP entity shall be in one of the following three receiving states:

- the Receive First Segment state, in which the SNDTCP entity shall expect the F bit set to 1 in the next received SN-PDU;
- the Receive Subsequent Segment state, in which the SNDTCP entity shall expect the F bit set to 0 in the next received SN-PDU; or
- the Discard state, in which the SNDTCP entity shall discard any SN-PDU received.

The Receive First Segment state shall be entered:

- upon receipt of an SNSM-ACTIVATE.indication;
- upon receipt of an SNSM-MODIFY.indication which indicates a change in SAPI or a change in peer-to-peer LLC operation mode;
- upon receipt of an LL-ESTABLISH.indication or an LL-ESTABLISH.confirm; or
- when the M bit is set to 0 in the received SN-PDU, except for situations specified in subclause 6.7.4.

The Receive Subsequent Segment state shall be entered:

- when the M bit is set to 1 in the received SN-PDU, except for situations specified in subclause 6.7.4.

6.7.2 Segmentation and reassembly in acknowledged mode

Segmentation and reassembly in acknowledged mode shall follow the general procedures stated in subclause 6.7.1.

6.7.3 Segmentation and reassembly in unacknowledged mode

In addition to the general procedure in subclause 6.7.1, a segment number shall be used due to the unreliable nature of the unacknowledged mode.

The Segment number is a sequence number assigned to each SN-UNITDATA PDU. The sequence number shall be set to 0 in the first SN-UNITDATA PDU of an N-PDU, and incremented by 1 for each subsequent SN-UNITDATA PDU. Modulo 16 operation is applied.

The received segments belonging to the same N-PDU shall be re-ordered, if possible. If a timer (implementation dependent) elapses before all segments are received, the segments shall be discarded. Reassembly operation described in subclauses 6.7.1 and 6.7.4 shall be performed after re-ordering.

6.7.4 Exception situations

6.7.4.1 Receive First Segment state

If an SN-UNITDATA PDU is received with the F bit set to 0, the SN-UNITDATA PDU shall be discarded. The Receive First Segment state shall be entered if the M bit is set to 0, otherwise the Discard state shall be entered.

If an SN-DATA PDU is received with the F bit set to 0, the SN-DATA PDU shall be discarded, and the acknowledged LLC operation shall be re-established for the SAPI used.

6.7.4.2 Receive Subsequent Segment state

If an SN-UNITDATA PDU is received with the F bit set to 1, and if DCOMP or PCOMP is different from those in the first segment, then the SN-UNITDATA PDU and all previous segments belonging to the same N-PDU shall be discarded. The Received First Segment state shall be entered if the M bit is set to 0, otherwise the Discard state shall be entered.

If an SN-DATA PDU is received with the F bit set to 1, and if DCOMP, PCOMP or N-PDU number is different from those in the first segment, then the SN-DATA PDU and all previous segments belonging to the same N-PDU shall be discarded, and the acknowledged LLC operation shall be re-established for the SAPI used.

6.7.4.3 Discard state

If an SN-PDU is received with the M bit set to 1, the SN-PDU shall be discarded and the SNDCP entity shall remain in the Discard state.

If an SN-PDU is received with the M bit set to 0, the SN-PDU shall be discarded and the Receive First Segment state entered.

6.8 XID parameter negotiation

Negotiation of XID parameters between peer SNDCP entities may be carried out to ensure optimal information transfer. The parameters are called SNDCP exchange identity (XID) parameters.

SNDCP XID parameter negotiation may be initiated by the SNDCP entity at the MS or at the SGSN. The MS shall initiate SNDCP XID negotiation upon receipt of SNSM-ACTIVATE.indication, if SNDCP XID parameters are to be changed. The SGSN shall initiate SNDCP XID negotiation upon receipt of the SNSM-MODIFY.indication primitive if an NSAPI has been put into use (in the case of an Inter-SGSN Routing Area Update), or if the change in QoS profile to an existing NSAPI results in a change in compressor(s) used by the NSAPI.

When an NSAPI no longer uses a compression entity due to a PDP context deactivation or a PDP context modification, an SNDCP XID negotiation shall be performed to remove the NSAPI from the Applicable NSAPIs of the compression entity. The negotiation shall be initiated by the MS upon receipt of the SNSM-DEACTIVATE.indication with XID Negotiation Indicator in the case of explicit PDP context deactivation by peer-to-peer signalling between the SM entities. The negotiation shall be initiated by the SGSN upon receipt of the SNSM-MODIFY.indication in the case of PDP context modification. If a PDP context is deactivated locally, without peer-to-peer signalling between the SM entities, the SM entity at the MS and the SM entity at the SGSN each shall send an SNSM-DEACTIVATE.indication without XID Negotiation Indicator to its respective SNDCP entity. Upon receipt of this primitive without XID Negotiation Indicator the SNDCP entity shall remove the NSAPI from the Applicable NSAPIs of the compression entity without any XID negotiation.

The XID negotiation is a one-step procedure; i.e. the initiating end proposes parameter values, and the responding end either accepts these or offers different values in their place according to the XID negotiation rules described in the present document; the rules limit the range of parameter values as well as the sense of negotiation. The initiating end accepts (or rejects) the values in the response; this concludes the negotiation.

The block format for the SNDCP XID parameter negotiation is shown in figure 10. Not all parameters have to be included in the XID block, only parameters that are negotiated. Parameters may be included in any order. Also it shall be possible to negotiate parameters for more than one NSAPI in one XID block since more than one NSAPI can use the same SAPI.

Bit	8	7	6	5	4	3	2	1
Octet 1	Parameter type=0							
Octet 2	Length=1							
Octet 3	Version number							
Octet 4	Parameter type=1							
Octet 5	Length=n-5							
Octet 6	P	X	X	Entity number				
Octet 7 (optional)								
Octet 8	Length=k-8							
Octet 9 ... (optional)								
Octet j	High-order octet							
...	...							
Octet k	Low-order octet							
Octet k+1	P	X	X	Entity number				
Octet k+2 (optional)								
Octet k+3	Length=m-(k+3)							
Octet k+4 ... (optional)								
Octet k+y	High-order octet							
...	...							
Octet m	Low-order octet							
...	...							
Octet n	Low-order octet							
Octet n+1	Parameter type=2							
Octet n+2	Length=r-(n+2)							
Octet n+3	P	X	X	Entity number				
Octet n+4 (optional)								
Octet n+5	Length=p-(n+5)							
Octet n+6 ... (optional)								
Octet n+w	High-order octet							
...	...							
Octet p	Low-order octet							
Octet p+1	P	X	X	Entity number				
Octet p+2 (optional)								
Octet p+3	Length=q-(p+3)							
Octet p+4 ... (optional)								
Octet p+v	High-order octet							
...	...							
Octet q	Low-order octet							
...	...							
Octet r	Low-order octet							

Figure 10: Example of SNDCP XID block format

The SNDCP user uses SN-XID.request to initiate the negotiation of the XID parameters. The SNDCP entity sends the proposed SNDCP XID parameters to the LLC SAP with the LL-XID.request or LL-ESTABLISH.request. The LLC SAP shall issue an XID command containing the SNDCP XID parameters (see 3GPP TS 44.064 [6]). The peer LLC SAP shall, upon receipt of the XID command, indicate the SNDCP XID parameters to SNDCP entity using LL-XID.indication or LL-ESTABLISH.indication. The peer SNDCP entity shall select appropriate values for the proposed parameters or negotiate the appropriate values with the SNDCP user entity with the SN-XID.indication and SN-XID.response primitives. When the appropriate parameter values are known by the peer SNDCP entity, it shall use the LL-XID.response or LL-ESTABLISH.response primitive to continue negotiation. Upon reception of the response, the LLC SAP shall send the received parameters to the SNDCP entity using the LL-XID.confirm or LL-ESTABLISH.confirm primitive. The SNDCP entity delivers the negotiated parameters to the SNDCP user. This is illustrated in figure 11. The originator of the negotiation shall apply the new parameter values after it has received the 'confirm' primitive. The responding end of the negotiation shall apply the new parameter values after it has sent the replying 'response' primitive.

Following the sending of the LL-XID.request or LL-ESTABLISH.request primitive with requested SNDCP XID parameters, the SNDCP layer shall suspend the transfer of LL-DATA primitives to the LLC SAP to which the LL-XID.request or LL-ESTABLISH.request is sent, but may continue the transfer of LL-UNITDATA primitives to that LLC SAP with the following restrictions:

- if the transfer of a compressed N-PDU is ongoing when the SN-XID.request is received, the SNDCP layer shall complete the transfer of this N-PDU before sending the LL-XID.request or LL-ESTABLISH.request primitive with requested SNDCP XID parameters; and
- the SN-PDUs transferred in the LL-UNITDATA primitives during the SNDCP XID negotiation shall be uncompressed.

When the SNDCP XID negotiation has been successfully completed, the SNDCP layer shall resume the transfer of LL-DATA primitives. If the transfer of LL-UNITDATA primitives was suspended, it shall also be resumed.

The SNDCP XID negotiation ends through one of the following means:

- successful (receiving LL-XID.confirm or LL-ESTABLISH.confirm);
- failure (receiving LL-RELEASE.indication, or LL-STATUS.indication); or
- successful following collision resolution (receiving LL-ESTABLISH.indication and sending LL-ESTABLISH.response, or receiving LL-XID.indication and sending LL-XID.response, see subclause 6.2.1.4).

LLC may also initiate LLC XID negotiation, in which case LLC may send an LL-XID.indication to inform SNDCP the values of N201-I and N201-U. This is illustrated in figure 12. If the SNDCP entity receives an LL-XID.indication without an SNDCP XID block, it shall not respond with the LL-XID.response primitive.

Negotiation of SNDCP version number is always between the peer SNDCP entities. The version number is not known by the SNDCP user. However, negotiation of the parameters for compression algorithms may be carried out between the SNDCP user entities.

Negotiation of SNDCP XID parameters for an NSAPI shall be carried out in the SAPI to which the NSAPI is mapped.

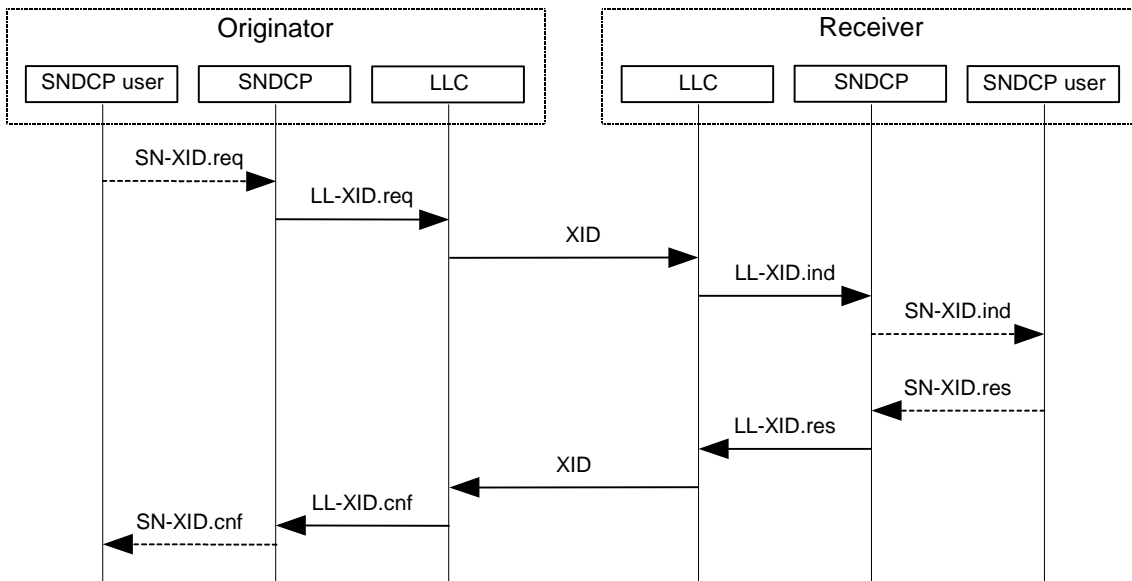

Figure 11: SNDCP XID negotiation procedure

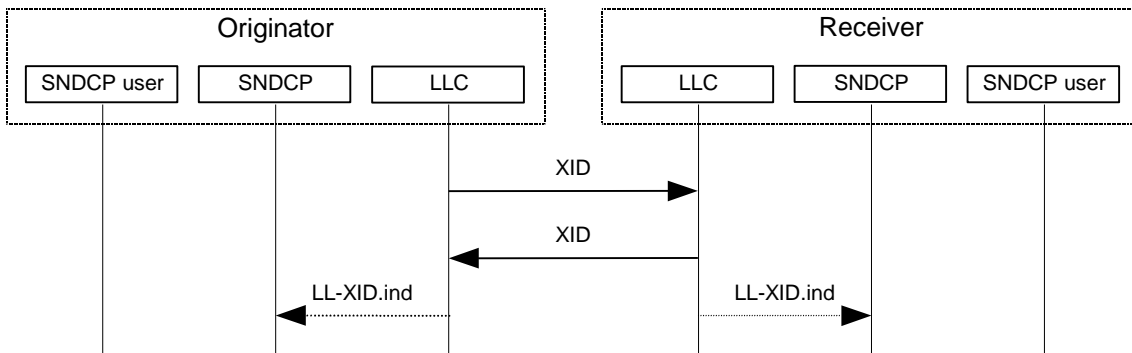

Figure 12: LLC XID negotiation procedure

6.8.1 Negotiation of compression entities

For parameter type 1 and 2, multiple compression fields (as shown in figure 7 and figure 9) may be specified. Each compression field corresponds to a compression entity.

In each compression field, the "Applicable NSAPIs" parameter indicates the NSAPIs that uses the compression entity. The parameter, if included, shall consist of 2 octets. Multiple NSAPIs may share the same compression entity by setting multiple bits in the parameter. NSAPIs requiring acknowledged peer-to-peer LLC operation and unacknowledged peer-to-peer LLC operation shall not share the same compressor (see subclause 6.10).

During SNDCP XID negotiation or re-negotiation, if a parameter type is specified in the SNDCP XID block, compression entities currently in use and compression entities proposed to be added may be included in the SNDCP XID block. Not all entities need to be included in the SNDCP XID block. If a compression entity is not included, the value of its parameters shall be determined by the rules defined in subclause 6.8.2.

If, implicitly or explicitly (see subclause 6.8.2), a compression entity is specified in the responding SNDCP XID block with one or more bits set to 1 in the "Applicable NSAPIs" parameter, the compression entity shall be created (if it does not exist yet).

If, implicitly or explicitly, a compression entity is specified in the responding SNDCP XID block with no bit set to 1 in the "Applicable NSAPIs" parameter, the compression entity shall be deleted (if it currently exists).

If an SNDCP entity receives a proposal for a compression entity containing an unknown algorithm, it shall reject this compression entity explicitly by setting the bits in the "Applicable NSAPIs" parameter in the responding SNDCP XID block to 0.

NOTE: Some legacy MS implementations of SDNCP version 0 will ignore a proposed compression entity containing an unknown algorithm and will not reply with an explicit rejection.

If, implicitly or explicitly, one or more bits are set to 1 in the "Applicable NSAPIs" parameter of a compression entity in the responding SNDCP XID block, the NSAPIs corresponding to these bits shall start using (or continue to use) the compression entity.

If, implicitly or explicitly, one or more bits are set to 0 in the "Applicable NSAPIs" parameter of a compression entity in the responding SNDCP XID block, the NSAPIs corresponding to these bits shall release the compression entity (if they have been using the compression entity).

6.8.1a Negotiation of SNDCP version

An SNDCP entity supporting this version of SNDCP shall set the version number in the originating SNDCP XID block to 1. For the sense of negotiation of the version number see clause 8, table 8.

6.8.2 Values of SNDCP XID parameters

In this subclause, the term "parameter" refers to an SNDCP XID parameter, a compression field (for parameter type 1 or 2), or a parameter for a compression field.

If an SNDCP XID parameter has not been negotiated, default values shall apply. The default value for a compression field (entity) is "non-existing".

If the originating SNDCP XID block does not include a parameter (implicit command), it shall be treated as equivalent to requesting for the current value for the parameter. The responder may explicitly include this parameter in its response. If the responder explicitly includes the parameter in the response, then it shall also explicitly include this parameter in every SNDCP XID response until the parameter has been explicitly negotiated, either by responding to an SNDCP XID command that included the parameter, or by explicitly including the parameter the next time an SNDCP XID command is transmitted.

If a parameter is included in the originating SNDCP XID block and the responder does not include the parameter in its response (implicit response), it shall be treated as equivalent to responding with the value proposed by the originator.

If both the originator and the responder do not include a parameter in the negotiation, the value of the parameter is not changed.

6.8.3 Exception handling

In this subclause, the term "parameter" may refer, wherever applicable, to an SNDCP XID parameter, a compression field (for parameter type 1 or 2), or a parameter for a compression field.

If the originating SNDCP XID block includes an SNDCP XID parameter with unrecognised Parameter Type field (as specified in clause 8, table 8), the parameter shall be ignored by the responder.

If the originating SNDCP XID block includes a parameter with unsupported length or an out-of-range value, then the responder shall respond to the parameter with lengths and values set according to the responder's preference.

If the originating SNDCP XID block includes parameter type 1 or 2 which violates the rules in subclause 6.8.1, the responder shall treat the parameter as not transmitted by the originator, and responds according to subclause 6.8.2.

If the originating SNDCP XID block includes a parameter with duplicated instances, the subsequent instances of the duplicated parameter shall be ignored.

If the originating SNDCP XID block is sent on LL-XID primitives and contains prohibited changes (see subclauses 6.5.1.2 and 6.6.1.2) to the parameters of compression entities used with acknowledged peer-to-peer LLC operation, then the responder shall respond with these parameters set to their previously-negotiated values.

In the originating SNDCP XID block, excluding the collision scenarios described in subclause 6.5.1.1.3, when an assigned entity number is included with the P bit set to 1, the algorithm and the PCOMP and DCOMP fields shall be ignored if they are the same as the previously-assigned values. If the algorithm and PCOMP or DCOMP fields are not the same as the previously-assigned values, then the Applicable NSAPIs field of the compression field in question shall

be set to 0 in the response, and an SNSM-STATUS.request primitive with Cause "invalid XID command" shall be sent to the SM sub-layer. SM shall then deactivate all PDP contexts for this SAPI.

In the originating SNDCP XID block, if an unassigned entity number is included with the P bit set to 0, then the Applicable NSAPIs field in the response shall be set to 0.

In the originating SNDCP XID block, excluding the collision scenarios described in subclause 6.5.1.1.3, if one or more of the PCOMP or DCOMP specified is already assigned to a different compression algorithm, then the Applicable NSAPIs field of the compression field in question shall be set to 0 in the response, and an SNSM-STATUS.request primitive with Cause "invalid XID command" shall be sent to the SM sub-layer. SM shall then deactivate all PDP contexts for this SAPI.

In the originating SNDCP XID block, if one or more new PCOMP or DCOMP values are specified for an existing compression algorithm, then the Applicable NSAPIs field of the compression field in question shall be set to 0 in the response, and an SNSM-STATUS.request primitive with Cause "invalid XID command" shall be sent to the SM sub-layer. SM shall then deactivate all PDP contexts for this SAPI.

If the responding SNDCP XID block includes an SNDCP XID parameter with unrecognised Parameter Type field (see clause 8, table 8), unsupported length, an out-of-range value or a value violating the sense of negotiation, a parameter type 1 or 2 which violates the rules in subclause 6.8.1, a parameter with duplicated instances, contains prohibited changes (see subclauses 6.5.1.2 and 6.6.1.2) to the parameters of compression entities used with acknowledged peer-to-peer LLC operation when the SNDCP XID block is sent on LL-XID primitives, or a compression field with the P bit set to 1, then the originator shall ignore the block and reinitiate the negotiation. If the renegotiation fails for an implementation-specific number of times, the originating SNDCP layer shall send an SNSM-STATUS.request primitive with Cause "invalid XID response" to the SM sub-layer. SM shall then deactivate all PDP contexts for this SAPI.

If the LLC layer indicates that the XID parameter negotiation failed, by sending an LL-RELEASE.indication with Cause "no peer response" or an LL-STATUS.indication with Cause "no peer response", then, as an implementation option, the SNDCP layer may wait for an implementation-specific amount of time and re-invoke the XID negotiation procedure.

6.9 Data transfer

6.9.1 Acknowledged mode

The SNDCP entity shall initiate acknowledged data transmission only if the PDP context for the NSAPI identified in the SN-DATA.request has been activated and if acknowledged LLC operation has been established.

The N-PDU number in acknowledged mode is a number assigned to each N-PDU received by SNDCP through an SN-DATA.request and to each feedback N-PDU generated by a local compression entity. N-PDU numbers for different NSAPIs shall be assigned independently. The N-PDU number shall be included in the SNDCP header of the first segment of an N-PDU.

NOTE: A feedback N-PDU can be e.g. a context state packet generated by a protocol control information compression entity using RFC 2507 [10] or a standalone feedback packet generated by a protocol control information compression entity using RFC 3095 [12].

Two variables, the Send N-PDU number and the Receive N-PDU number, shall be maintained for each NSAPI using acknowledged peer-to-peer LLC operation. When an NSAPI using acknowledged peer-to-peer LLC operation is activated, the Send N-PDU number and the Receive N-PDU number shall be set to 0. The Send N-PDU number and Receive N-PDU number shall also be set as described in subclause 5.1.2.22. Modulo 256 operation shall be applied to the Send N-PDU number and the Receive N-PDU number.

Upon reception of an SN-DATA.request, the SNDCP entity shall assign to the N-PDU received the current value of the Send N-PDU number as the N-PDU number, increment the Send N-PDU number by 1, perform the compression and segmentation functions, then forward the SN-PDU(s) in LL-DATA.request to the LLC layer. If an N-PDU number is already present in the SN-DATA.request, then no new N-PDU number shall be assigned to the N-PDU, and the Send N-PDU number shall not be incremented. The N-PDU shall be stored into a buffer in the SNDCP entity. The buffered N-PDU shall be deleted when the SN-DATA PDU carrying the last segment of the N-PDU is confirmed by an LL-DATA.confirm primitive, or when the entire N-PDU is confirmed by an SNSM-SEQUENCE.indication primitive.

(unacknowledged) by 1, compress and segment the information, then forward the SN-PDU(s) in LL-UNITDATA.request to the LLC layer. The N-PDU shall be deleted immediately after the data has been delivered to the LLC layer.

Upon reception of a feedback N-PDU generated by a local compression entity, the SNDCP entity shall assign the current value of the Send N-PDU number (unacknowledged) as the N-PDU number of the feedback N-PDU, increment the Send N-PDU number (unacknowledged) by 1, perform segmentation functions if required, then forward the SN-PDU(s) in LL-UNITDATA.request to the LLC layer. The N-PDU shall be deleted immediately after the data has been delivered to the LLC layer.

When the peer SNDCP entity receives the SN-PDU(s) in the LL-UNITDATA.indication primitive, the SNDCP entity shall reassemble and decompress the SN-PDU(s), then forwards the N-PDU to the SNDCP user with the SN-UNITDATA.indication. The correct SNDCP user is identified by the NSAPI field in the SN-PDU(s).

If an SN-UNITDATA PDU (T bit set to 1) is received by an NSAPI that does not use unacknowledged mode, the PDU shall be ignored without error notification.

The SNDCP entity shall detect lost SN-PDUs. The SNDCP entity shall discard duplicate SN-PDUs and re-order out-of-sequence SN-PDUs, if possible.

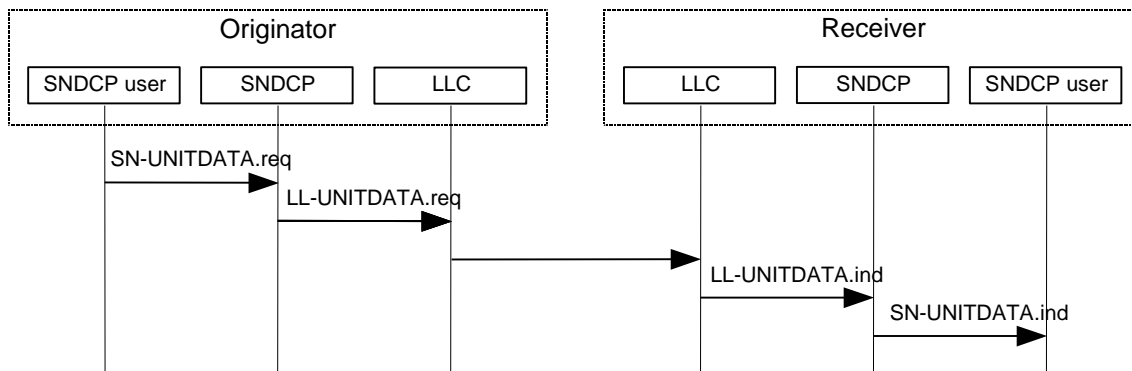

Figure 14: SNDCP unacknowledged data transfer

6.10 Possible combinations of SNDCP protocol functions and their connection to service access points

The following combinations of SNDCP protocol functions are allowed:

- One or several NSAPIs may use one SAPI.
- Only one SAPI shall be used by one NSAPI.
- One or several NSAPIs may use the same protocol control information compression entity.
- One NSAPI may use zero or one protocol control information compression entities.
- One or several NSAPIs may use the same data compression entity.
- One NSAPI may use zero or one data compression entities.
- Separate data compression entities shall be used for SN-DATA and SN-UNITDATA PDUs.
- Separate protocol control information compression entities shall be used for SN-DATA and SN-UNITDATA PDUs.
- One data compression entity shall be connected to one SAPI.
- One protocol control information compression entity shall be connected to one SAPI.
- One or several protocol control information compression entities may be connected to the same data compression entity.

- One protocol control information compression entity shall be connected to zero, one, or several data compression entities.

7 Definition of SN-PDU

7.1 Format convention

7.1.1 Numbering convention

The convention used in the present document is illustrated in figure 15. The bits are grouped into octets. The bits of an octet are shown horizontally and are numbered from 1 to 8. Multiple octets are shown vertically and are numbered from 1 to N.

Bit	8	7	6	5	4	3	2	1
Oct 1								
2								
...								
N-1								
N								

Figure 15: Format convention

7.1.2 Order of transmission

SN-PDUs are transferred between the SNDCP layer and LLC layer in units of octets, in ascending numerical octet order (i.e. octet 1, 2, ..., N-1, N). The order of bit transmission is specific to the underlying protocols used across the Um interface and the Gb interface.

7.1.3 Field mapping convention

When a field is contained within a single octet, the lowest bit number of the field represents the lowest order value. When a field spans more than one octet, the order of bit values within each octet progressively decreases as the octet number increases. In that part of the field contained in a given octet the lowest bit number represents the lowest order value.

For example, a bit number can be identified as a couple (o, b) where o is the octet number and b is the relative bit number within the octet. Figure 16 illustrates a field that spans from bit (1, 3) to bit (2, 7). The high order bit of the field is mapped on bit (1, 3) and the low order bit is mapped on bit (2, 7).

Bit	8	7	6	5	4	3	2	1
1st octet of field						2^4	2^3	2^2
2nd octet of field	2^7	2^6						

Figure 16: Field mapping convention

Figure 17 illustrates an NSAPI field that spans from bit (1,8) to bit (2,1). NSAPI 15 is mapped to bit (1,8) and the other NSAPIs are mapped in decreasingly order until NSAPI 0 that is mapped to bit (2,1). A bit set to 0 means that the compression entity is not applicable to the corresponding NSAPI. A bit set to 1 means that the compression entity is applicable to the corresponding NSAPI.

Bit	8	7	6	5	4	3	2	1
1st octet of field	15	14	13	12	11	10	9	8
2nd octet of field	7	6	5	4	3	2	1	0

Figure 17: NSAPI mapping convention

7.2 SN-PDU Formats

Each SN-PDU shall contain an integral number of octets, and shall comprise a header part and a data part. An SN-PDU shall contain data from a single N-PDU only. Two different SN-PDU formats are defined. The SN-DATA PDU shall be used for acknowledged data transfer and SN-UNITDATA PDU for unacknowledged data transfer.

Bit	8	7	6	5	4	3	2	1
Oct 1	X	F	T	M	NSAPI			
2	DCOMP				PCOMP			
3	N-PDU number - acknowledged mode							
...	Data segment							
N								

Figure 18: SN-DATA PDU format

Bit	8	7	6	5	4	3	2	1
Oct 1	X	F	T	M	NSAPI			
2	DCOMP				PCOMP			
3	Segment number				N-PDU number - unacknowledged mode			
4	N-PDU number - unacknowledged mode (continued)							
...	Data segment							
N								

Figure 19: SN-UNITDATA PDU format

More bit (M):

- 0 Last segment of N-PDU.
- 1 Not the last segment of N-PDU, more segments to follow.

SN-PDU Type (T):

- 0 SN-DATA PDU.
- 1 SN-UNITDATA PDU.

First segment indicator bit (F):

- 0 This SN-PDU is not the first segment of an N-PDU.

The octet including DCOMP and PCOMP is not included in the SN-DATA PDU or SN-UNITDATA PDU format. Also the octet for N-PDU number for acknowledged mode is not included in the SN-DATA PDU format.

- 1 This SN-PDU is the first segment of an N-PDU. The octet for DCOMP and PCOMP is included in the SN-DATA PDU or SN-UNITDATA PDU format. Also the octet for N-PDU number for acknowledged mode is included in the SN-DATA PDU format.

Spare bit (X):

0 Shall be set to 0 by the transmitting SNDCP entity and ignored by the receiving SNDCP entity.

NSAPI:

0 Escape mechanism for future extensions.

1 Point-to-Multipoint Multicast (PTM-M) information for Multimedia Broadcast/Multicast Service (MBMS).

2-4 Reserved for future use.

5-15 Dynamically allocated NSAPI value (see subclause 6.1).

The SGSN shall ignore any uplink data traffic of SN-PDUs with an NSAPI = 1.

SN-PDU with an unallocated NSAPI value shall be ignored by the receiving SNDCP entity without error notification.

Data compression coding (DCOMP):

0 No compression.

1-14 Points to the data compression identifier negotiated dynamically (see subclause 6.6).

15 Reserved for future extensions.

SN-PDU with an unallocated DCOMP value shall be ignored by the receiving SNDCP entity without error notification.

Protocol control information compression coding (PCOMP):

0 No compression.

1-14 Points to the protocol control information compression identifier negotiated dynamically (see subclause 6.5).

15 Reserved for future extensions.

SN-PDU with an unallocated PCOMP value shall be ignored by the receiving SNDCP entity without error notification.

Segment number:

0-15 Sequence number for segments carrying an N-PDU.

N-PDU number - acknowledged mode:

0-255 N-PDU number of the N-PDU.

N-PDU number - unacknowledged mode:

0-4095 N-PDU number of the N-PDU.

8 SNDCP XID parameters

The SNDCP XID parameters are shown in table 8:

Table 8: SNDCP XID parameters

Parameter name	Parameter Type	Length	Format	Range	Default value	Units	Sense of negotiation
Version number	0	1	0000bbbb	0-15	0	-	down
Data Compression	1	variable	See subclause 6.6.1				
Protocol Control Information Compression	2	variable	See subclause 6.5.1				

NOTE: The current version of SNDCP is 1. The default value for the version number is 0.

Annex A (informative): Change History

SMG#	CR#	REV.	NEW REV.	SUBJECT
SMG#31			8.0.0	Creation of the specification for R99 based on V7.3.0

TSG Meeting	TSG Doc number	TSGWG doc number	Spec	CR	R v	Ph	C at	Vers Old	Vers New	Subject	Work item	Remarks
NP-09								8.0.0	8.1.0			GSM to 3GPP format is changed
NP-09	NP-000441	N1-001019	04.65	A070	1	R99	F	8.0.0	8.1.0	Deletion of PDP type X.25	GPRS	GSM to 3GPP format is changed
NP-09	NP-000441	N1-001025	04.65	A071	1	R99	F	8.0.0	8.1.0	Supporting RFC2507 Header Compression in SNDCP	GPRS	
NP-10								8.1.0	4.0.0			This CR changes the specification to Release 4 as 44.065
NP-10	NP-000675	N1-001178	04.65	A072		Rel-4	C	8.1.0	4.0.0	Support of V.44 Data Compression in SNDCP	TEI4	
NP-13	NP-010492	N1-011200	44.065	001		Rel-4	A	4.0.0	4.1.0	Conditions for header compression	GPRS	
NP-16			44.065			Rel-5		4.1.0	5.0.0	CN plenary decision to make this TS also for Release 5. Some editorials from ETSI secretariat are introduced.		June 2002
NP-20	NP-030284	N1-030934	44.065	004	4	Rel-6	B	5.0.0	6.0.0	Additional support of ROHC in SNDCP	TEI6	June 2003
NP-20	NP-030284	N1-030833	44.065	005	1	Rel-6	C	5.0.0	6.0.0	Multiple header compression algorithms handling	TEI6	June 2003
NP-21	NP-030416	N1-031074	44.065	007		Rel-6	A	6.0.0	6.1.0	Correction to References	TEI5	Sept 2003
NP-21	NP-030420	N1-031283	44.065	008	1	Rel-6	F	6.0.0	6.1.0	Corrections on Compression details	TEI6	Sept 2003
NP-22	NP-030486	N1-031652	44.065	012	1	Rel-6	F	6.1.0	6.2.0	Disabling of ROHC segmentation	TEI6	December 2003
NP-22	NP-030486	N1-031650	44.065	013	1	Rel-6	F	6.1.0	6.2.0	XID negotiation for IP compression	TEI6	December 2003
NP-25	NP-040387	N1-041408	44.065	014		Rel-6	B	6.2.0	6.3.0	Update of SNDCP - MBMS	MBMS	Sept 2004
NP-25	NP-040374	N1-041636	44.065	017	2	Rel-6	A	6.2.0	6.3.0	Negotiation of compression entities with unknown algorithm type	TEI4	Sept 2004
CP-28	CP-050062	C1-050787	44.065	21	2	Rel-6	B	6.3.0	6.4.0	Pre-defined Protocol control information compression types for MBMS	MBMS	June 2005

TSG Meeting	TSG Doc number	TSGWG doc number	Spec	CR	R v	Ph	C at	Vers Old	Vers New	Subject	Work item	Remarks
CP-29	CP-050356	C1-051205	44.065	025	4	Rel-6	F	6.4.0	6.5.0	Recommendation for FOHC context when used for MBMS ROHC	MBMS	Sept 2005
CP-29	CP-050356	C1-050862	44.065	026		Rel-6	F	6.4.0	6.5.0	MAX_HEADER is not used by ROHC as per RFC 3095	MBMS	Sept 2005
CP-29	CP-050449	C1-050921	44.065	027	2	Rel-6	B	6.4.0	6.5.0	Modifications for PS HO in A/Gb mode	SPSH AGB	Sept 2005
CP-32	CP-060267	C1-060958	44.065	0030	1	Rel-6	F	6.5.0	6.6.0	Handling of feedback N-PDU	TEI6	June 2006
CP-32	CP-060268	C1-061035	44.065	0032	1	Rel-6	F	6.5.0	6.6.0	Correction of the XID parameter negotiation sub-clause for LL-UNITDATA	SCSA GB	June 2006
CP-33	CP-060506	C1-061624	44.065	0034		Rel-7	F	6.6.0	7.0.0	Clean-up for ROHC segmentation	TEI7	Sept 2006
CP-42						Rel-8		7.0.0	8.0.0	Upgrade to Rel-8		Dec 2008
CP-46						Rel-9		8.0.0	9.0.0	Upgrade to Rel-9		Dec 2009
CP-51						Rel-10		9.0.0	10.0.0	Upgrade to Rel-10		March 2011
CP-57						Rel-11		10.0.0	11.0.0	Upgrade to Rel-11		Sept 2012