

# 3GPP TS 44.021 V11.0.0 (2012-09)

---

*Technical Specification*

## **3rd Generation Partnership Project; Technical Specification Group Core Network and Terminals; Rate adaption on the Mobile Station - Base Station System (MS - BSS) Interface (Release 11)**



The present document has been developed within the 3<sup>rd</sup> Generation Partnership Project (3GPP™) and may be further elaborated for the purposes of 3GPP.

The present document has not been subject to any approval process by the 3GPP Organisational Partners and shall not be implemented. This Specification is provided for future development work within 3GPP only. The Organisational Partners accept no liability for any use of this Specification. Specifications and reports for implementation of the 3GPP™ system should be obtained via the 3GPP Organisational Partners' Publications Offices.

---

Keywords

---

GSM, A/Gb mode, GERAN, BSS, adaption

**3GPP**

Postal address

---

3GPP support office address

---

650 Route des Lucioles - Sophia Antipolis  
Valbonne - FRANCE  
Tel.: +33 4 92 94 42 00 Fax: +33 4 93 65 47 16

Internet

---

<http://www.3gpp.org>

---

**Copyright Notification**

---

No part may be reproduced except as authorized by written permission.  
The copyright and the foregoing restriction extend to reproduction in all media.

© 2012, 3GPP Organizational Partners (ARIB, ATIS, CCSA, ETSI, TTA, TTC).  
All rights reserved.

UMTS™ is a Trade Mark of ETSI registered for the benefit of its members  
3GPP™ is a Trade Mark of ETSI registered for the benefit of its Members and of the 3GPP Organizational Partners  
LTE™ is a Trade Mark of ETSI registered for the benefit of its Members and of the 3GPP Organizational Partners  
GSM® and the GSM logo are registered and owned by the GSM Association

# Contents

Foreword .....	5
1 Scope .....	6
2 References, Definitions and Abbreviations .....	6
2.1 References .....	6
2.2 Definitions .....	7
2.2 Abbreviations .....	7
3 General approach .....	7
3.1 Overview of data rates and configurations .....	7
4 The RA0 Function .....	9
4.1 Asynchronous-to-Synchronous Conversion (RA0) .....	9
4.2 Break signal .....	9
4.3 Overspeed/Underspeed .....	9
4.4 Parity Bits .....	10
4.5 Flow Control .....	10
5 Void .....	10
6 Void .....	10
7 Void .....	10
8 The Relay Functions RA1/RA1', RA1'/RA1'', RA1'/RAA' and RA1'/RAA'' .....	10
8.1 Single slot rates .....	10
8.1.1 Radio interface rate of 14,5 kbit/s .....	11
8.1.2 Radio Interface rate of 12 kbit/s .....	11
8.1.3 Radio Interface rate of 6 kbit/s .....	12
8.1.4 Radio Interface rate of 3,6 kbit/s (transparent services only) .....	13
8.1.5 Synchronisation .....	13
8.1.6 Idle frames .....	13
8.2 Multislot rates .....	13
8.2.1 AIURs up to 38,4 kbit/s using TCH/F9.6 and TCH/F4.8 channel codings .....	14
8.2.2 AIURs up to 64 kbit/s using TCH/F14.4 channel coding .....	14
8.2.3 AIUR of 48 kbit/s; Intermediate rate of 64 kbit/s; Radio interface rate of 5 x 12 kbit/s .....	14
8.2.4 AIUR of 56 kbit/s; Intermediate rate of 64 kbit/s, Radio interface rate of 5 x 12 kbit/s .....	15
8.2.5 AIUR of 64 kbit/s; Radio interface rate of 6 x 12 kbit/s .....	15
9 The EDGE multiplexing function .....	15
9.1 Data block distribution into the substreams by the Multiplexing function; TCH/F28.8 channel coding .....	16
9.1.1 AIUR of 57.6 kbit/s; Radio interface rate of 2 x 29.0 kbit/s .....	16
9.2 Data block distribution to the radio interface by the Multiplexing function; TCH/F32.0 channel coding .....	16
9.2.1 AIUR of 56 kbit/s; Radio interface rate of 2 x 32.0 kbit/s .....	16
9.2.2 AIUR of 64 kbit/s; Radio interface rate of 2 x 32.0 kbit/s .....	16
9.3 Data block distribution into the substreams by the Multiplexing function; TCH/F43.2 channel coding .....	17
10 The RA1' Function .....	17
10.1 Void .....	17
10.2 TCH/F9.6 and TCH/F4.8 channel codings .....	17
10.2.1 Network Independent Clocking .....	18
10.2.1.1 Multiframe Structure .....	18
10.2.1.2 Encoding and compensation .....	18
10.2.2 Synchronisation .....	19
10.2.3 Idle frames .....	19
10.3 TCH/F14.4 channel coding .....	19
10.3.1 Multiframe structure over the radio-interface .....	20
10.3.2 Radio-interface data block for TCH/F14.4 channel coding .....	21
10.3.3 Network independent clocking .....	21
10.3.3.1 Negative compensation .....	21

10.3.3.2	Positive compensation.....	21
11	The Split/Combine and Padding-functions .....	22
11.1	Data frame distribution into the substreams/channels by the Split/Combine function .....	22
11.1.1	Data frame distribution into the substreams/channels by the Split/Combine function (TCH/F9.6 and TCH/F4.8 channel codings) .....	22
11.1.2	Data block distribution into the substreams by the Split/Combine function (TCH/F14.4 channel coding) .....	22
11.2	Substream numbering in transparent operation .....	23
11.2.1	Substream numbering for TCH/F4.8 and TCH/F9.6 channel codings .....	23
11.2.2	Substream numbering for TCH/F14.4 and TCH/F28.8 channel codings .....	24
11.3	Substream Synchronisation.....	24
11.4	Void .....	24
11.5	Padding Functions .....	24
11.5.1	Padding for TCH/F9.6 and TCH/F4.8 .....	24
11.5.1.1	Padding for AIUR 14,4 kbit/s:.....	24
11.5.1.2	Padding for AIUR 64 kbit/s:.....	24
11.5.2	Padding for TCH/F14.4 channel coding .....	24
11.5.2.1	Padding for AIURs up to 38,4 kbit/s .....	24
11.5.2.2	Padding for AIURs of 48 kbit/s .....	25
11.5.2.3	Padding for AIURs of 56 kbit/s .....	25
11.5.2.4	Padding for AIURs of 64 kbit/s .....	25
11.6	Handling of the E1-E3 bits in multislot operation .....	25
12	Support of Non-Transparent Bearer Services.....	25
12.1	Support of non-transparent operation for TCH/F9.6 and TCH/F4.8 channel codings .....	25
12.2	Support of non-transparent operation for TCH/F14.4 channel coding .....	26
12.3	Support of non-transparent operation for TCH/F28.8 channel coding .....	26
12.4	Support of non-transparent operation for TCH/F43.2 channel coding .....	26
13	Figures on Frame structures .....	27
<b>Annex A (Informative):</b>	<b>Stacks of rate adaptation .....</b>	<b>32</b>
A.1	Stacks of rate adaptation for 9,6/4,8 kbit/s single slot operation .....	32
A.2	Stacks of rate adaptation for 14,4 kbit/s single slot operation .....	34
A.3	Stacks of rate adaptation for 9,6/4,8 kbit/s multi slot operation .....	36
A.4	Stacks of rate adaptation for 14,4 kbit/s multi slot operation .....	38
A.5	Stacks of rate adaptation for EDGE channels TCH28.8 and TCH/F43.2 (NT only) .....	40
<b>Annex B (Informative):</b>	<b>An example of mapping Network Independent Clocking information for TCH/F14.4 when the S-interface is deployed.....</b>	<b>42</b>
<b>Annex C (Informative):</b>	<b>Change history.....</b>	<b>43</b>

---

# Foreword

This Technical Specification has been produced by the 3<sup>rd</sup> Generation Partnership Project (3GPP).

The contents of the present document are subject to continuing work within the TSG and may change following formal TSG approval. Should the TSG modify the contents of the present document, it is re-released by the TSG with an identifying change of release date and an increase in version number as follows:

Version x.y.z

where:

- x the first digit:
  - 1 presented to TSG for information;
  - 2 presented to TSG for approval;
  - 3 or greater indicates TSG approved document under change control.
- y the second digit is incremented for all changes of substance, i.e. technical enhancements, corrections, updates, etc.
- z the third digit is incremented when editorial only changes have been incorporated in the document.

---

# 1 Scope

The present document defines the rate adaptation functions to be used in PLMN Mobile Stations (MS)s for adapting terminal interface data rates to the Mobile Station - Base Station System (MS-BSS) interface data rates in accordance with 3GPP TS 43.010 [3].

The provision of these functions will depend on the services a particular station is designed to support.

NOTE 1: The present document should be considered together with 3GPP TS 48.020 [9] (Rate Adaptation on the BSS-MSC Interface) to give a complete description of PLMN rate adaptation.

NOTE 2: The Gb interface does not play any role in the scope of the present document although the term "A/Gb mode" is used.

---

# 2 References, Definitions and Abbreviations

## 2.1 References

The following documents contain provisions which, through reference in this text, constitute provisions of the present document.

- References are either specific (identified by date of publication, edition number, version number, etc.) or non-specific.
- For a specific reference, subsequent revisions do not apply.
- For a non-specific reference, the latest version applies. In the case of a reference to a 3GPP document (including a GSM document), a non-specific reference implicitly refers to the latest version of that document in the same Release as the present document.

- [1] 3GPP TR 21.905: "Vocabulary for 3GPP specifications".
- [2] 3GPP TS 22.034: "High Speed Circuit Switched Data (HSCSD) -Stage 1".
- [3] 3GPP TS 43.010: "GSM Public Land Mobile Network (PLMN) connection types".
- [4] 3GPP TS 23.034: "High Speed Circuit Switched Data (HSCSD) - Stage 2 Service Description".
- [5] 3GPP TS 45.003: "Channel coding".
- [6] 3GPP TS 27.001: "General on Terminal Adaptation Functions (TAF) for Mobile Stations (MS)".
- [7] 3GPP TS 27.002: "Terminal Adaptation Functions (TAF) for services using asynchronous bearer capabilities".
- [8] Void.
- [9] 3GPP TS 48.020: "Rate adaption on the Base Station System - Mobile-services Switching Centre (BSS - MSC) interface".
- [10] ITU-T Recommendation V.110: "Support of data terminal equipments (DTEs) with V-Series interfaces by an integrated services digital network".
- [11] ITU-T Recommendation X.30: "Support of X.21, X.21 bis and X.20 bis based terminal equipments (DTEs) by integrated services digital network (ISDN)".
- [12] 3GPP TS 48.060: "Inband control of remote transcoders and rate adaptors for Enhanced Full Rate (EFR) and full rate traffic channels".

## 2.2 Definitions

For the purposes of the present document, the following terms and definitions apply.

**Overall data stream:** The data stream in those parts of the network where the data flow is not split into multiple channels.

**Substream:** Stream of data with explicit or implicit numbering between splitter and combiner functions.

**Channel:** A physical full rate channel on the radio interface (TCH/F) independent of the contents

**Multislot intermediate rate:** Intermediate rate per substream in those parts of the network where the overall data stream is split into substreams.

**Intermediate rate:** Intermediate rate in the overall data stream.

**Substream rate:** The user rate including padding, if applicable, on one individual substream

**EDGE channel:** A general term referring to channels based on 8PSK modulation; i.e. TCH/F28.8, TCH/F32.0, and TCH/F43.2.

## 2.2 Abbreviations

Abbreviations used in the present document are listed in 3GPP TR 21.905 [1].

---

## 3 General approach

3GPP TS 43.010 defines the PLMN connection types necessary to support the GSM PLMN data and telematic services.

Within the MS there are several different data rate adaptation functions - and a Split/Combine-function in case of a multislot data configuration - which are combined as shown in 3GPP TS 43.010 as part of the connection type.

The rate adaptation functions are RA0, RA1', RA1'/RA1'', RA1'/RAA'', RA1'/RAA' and RA1/RA1'. The RA0 is similar to the RA0 function described in ITU-T recommendation V.110 [11] with the exception of the conversion of the rates 14.4 and 28,8 kbit/s.

The RA1' function is similar to RA1 described in ITU-T recommendation V.110 [11] but has a reduced bit rate output compatible with the coding scheme proposed for data services on the radio interface.

The RA1/RA1', RA1'/RA1'', RA1'/RAA'' and RA1'/RAA' are relay functions, used as indicated in 3GPP TS 43.010.

In multislot data-configurations the overall data stream is split into parallel substreams between the Split/Combine-functions.

### 3.1 Overview of data rates and configurations

In Table 1, an overview of the supported transparent air-interface user rates is given. For each rate, also intermediate rates per channel between BTS and MSC, overall radio interface rates, and channel configurations are given. For single slot connections the intermediate rates are per channel carrying the overall data stream, whereas for multislot connections, the intermediate rates are per substream.

For single slot rates up to 4,8 kbit/s, the used intermediate rate is 8 kbit/s, and for the 9,6 kbit/s single slot rate 16 kbit/s.

For TCH/F9.6 and TCH/F4.8 channel codings, the multislot intermediate rates are 16 and 8 kbit/s per TCH/F, respectively.

For TCH/F14.4 channel coding, the multislot intermediate rate is 16 kbit/s per TCH/F.

Connections utilising TCH/F28.8 or TCH/F43.2 across the radio interface, use multislot combinations of TCH/F14.4 between BTS and MSC. Thus the corresponding multislot intermediate rate is 16 kbit/s.

No multislot intermediate rates are applicable to 56 and 64 kbit/s connections using TCH/F32.0 radio interface channels. The intermediate rate for the 32 kbit/s user rate using the TCH/F32.0 channel is 32 kbit/s.

**Table 1: AIUR/Multislot intermediate rates**

Air interface user rate	DTE/DCE statuses	RA0	RA1'/RA1 RA1'/RAA' RA1'/RA1'' RA1'/RAA'' (Note 4)		RA1'	
			Multislot intermediate rate	Frame type	Radio interface rate	Padding
≤ 600 bit/s	X	X	8 kbit/s	80 bit frames	3,6 kbit/s	
1200 bit/s	X	X	8 kbit/s	80 bit frames	3,6 kbit/s	
2,4 kbit/s	X	X	8 kbit/s	80 bit frames	3,6 kbit/s	
4,8 kbit/s	X	X	8 kbit/s	80 bit frames	6 kbit/s	
9,6 kbit/s	X	X	16 kbit/s or 2×8 kbit/s	80 bit frames	12 kbit/s or 2×6 kbit/s	
14,4 kbit/s	X	X	2×16 kbit/s or 3×8 kbit/s	80 bit frames	2×12 kbit/s or 3×6 kbit/s	P (note 1)
			16 kbit/s	Note 5	14,5 kbit/s	
19,2 kbit/s	X	X	2×16 kbit/s or 4×8 kbit/s	80 bit frames	2×12 kbit/s or 4×6 kbit/s	
28,8 kbit/s	X	X	3×16 kbit/s	80 bit frames	3×12 kbit/s	
			2 x 16 kbit/s	Note 5	2×14,5 kbit/s	
32 kbit/s			1 x 32 kbit/s		1 x 32 kbit/s	
38,4 kbit/s	X	X	4×16 kbit/s	80 bit frames	4×12 kbit/s	
			3 x 16 kbit/s	Note 5	3×14,5 kbit/s	P (note 1)
43.2 kbit/s Note 6	X		3 x 16 kbit/s	Note 5	1×43.5 kbit/s	
48 kbit/s	X		Note 2	Note 2	5×12 kbit/s	
			4 x 16 kbit/s	Note 5	4×14,5 kbit/s	P (note 1)
56 kbit/s			Note 2	Note 2	5×12 kbit/s (note 3)	
			4x16 kbit/s	Note 5	4×14,5 kbit/s	P (note 1)
			Note 2	Note 2	2×32.0 kbit/s	
64 kbit/s			Note 2	Note 2	6×12 kbit/s (note 3)	P (note 1)
					5×14,5 kbit/s	(note 1)
			Note 2	Note 2	2×32.0 kbit/s	

P=Padding used

NOTE 1: For information on the padding procedure, please refer to clause 11 of the present document.

NOTE 2: No multislot intermediate rate; substreams combined at the BSS with a resulting data rate of 64 kbit/s between BSS and MSC.

NOTE 3: AIUR 11,2 kbit/s per channel

NOTE 4: Different relay rate adaptation functions exist at the network side:

- RA1'/RA1 applies if the radio interface rate is  $n \times 3,6, 6$  or  $12$  kbit/s and the AIUR is less than 48 kbit/s,
- RA1'/RAA' applies if the radio interface rate is  $n \times 14,5, 29$  or  $43,2$  kbit/s and the AIUR is less than 64 kbit/s,
- RA1'/RA1'' applies if the radio interface rate is  $n \times 12$  kbit/s and the AIUR is equal to 48, 56 or 64 kbit/s,
- RA1'/RAA'' applies if the radio interface rate is  $n \times 14,5$  kbit/s and the AIUR is equal to 64 kbit/s,
- a relay rate adaptation function does not apply if the radio interface rate is  $n \times 32$  kbit/s



NOTE 5: A 320-bit frame format described in 3GPP TS 48.060.

NOTE 6: Used only in non-transparent configurations.

## 4 The RA0 Function

### 4.1 Asynchronous-to-Synchronous Conversion (RA0)

The RA0 Function is only used with asynchronous interfaces. Incoming asynchronous data is padded by the addition of stop elements to fit the same or nearest higher synchronous rate defined by 2 to the power n (where  $n \leq 6$ ) times 600 bit/s, 14,4 kbit/s or 28,8 kbit/s. Thus the 300 bit/s user data signalling rate shall be adapted to a synchronous 600 bit/s stream. The resultant synchronous stream is fed to RA1 or Split/Combine Function. The RA0 used in PLMN is not identical to that described in ITU-T Recommendation V.110 which converts 14,4 and 28,8 kbit/s user rates to 19,2 and 38,4 kbit/s, respectively.

Asynchronous user rate	Synchronous user rate
$\leq 0.6$ kbit/s	0.6 kbit/s
1,2 kbit/s	1,2 kbit/s
2,4 kbit/s	2,4 kbit/s
4,8 kbit/s	4,8 kbit/s
9,6 kbit/s	9,6 kbit/s
14,4 kbit/s	14,4 kbit/s
19,2 kbit/s	19,2 kbit/s
28,8 kbit/s	28,8 kbit/s
38,4 kbit/s	38,4 kbit/s

### 4.2 Break signal

The RA0 shall detect and transmit the break signal in the following fashion:

If the converter detects  $2M$  to  $2M+3$  bits, all of start polarity, where  $M$  is the number of bits per character in the selected format including start and stops bits, the converter shall transmit  $2M+3$  bits of start polarity.

If the converter detects more than  $2M+3$  bits all of start polarity, the converter shall transmit all these bits as start polarity.

The  $2M+3$  or more bits of start polarity received from the transmitting sides shall be output to the receiving terminal.

The terminal shall transmit on circuit 103 at least  $2M$  bits stop polarity after the start polarity break signal before sending further data character. The converter shall then regain character synchronism from the following stop to start transition.

### 4.3 Overspeed/Underspeed

A RA0 shall insert additional stop elements when its associated terminal is transmitting with a lower than nominal character rate. If the terminal is transmitting characters with an overspeed of up to 1 %, the asynchronous-to-synchronous converter may delete stop elements as often as is necessary to a maximum of one for every eight characters at 1 % overspeed. The converter on the receiving side shall detect the deleted stop elements and reinsert them in the received data stream (circuit 104).

The realization of overspeed handling, as described above, at the interface to the associated terminal is implementation dependent. Possible implementations are e.g. the reduction of the length of the stop elements according to V.110 [9] or increased data rates between the TA and terminal.

## 4.4 Parity Bits

Possible parity bits included in the user data are considered as data bits by the RA0 function.

## 4.5 Flow Control

Where applicable, this function is as specified in the relevant terminal adaptation function Specification (see 3GPP TS 07 series).

---

## 5 Void

---

## 6 Void

---

## 7 Void

---

## 8 The Relay Functions RA1/RA1', RA1'/RA1'', RA1'/RAA' and RA1'/RAA''

The relay functions realise conversions on the infrastructure side in both transparent and non-transparent cases as specified in 3GPP TS 43.010.

The RA1/RA1' function shall be used for channel codings TCH/F4.8 and TCH/F9.6 if the AIUR is less than 48 kbit/s. It converts between the intermediate rate and the input rate to the channel coder.

The RA1'/RA1'' function shall be used for channel codings TCH/F4.8 and TCH/F9.6 if the AIUR is equal to 48, 56 or 64 kbit/s. It converts between the 64 kbit/s data stream and the input rate to the channel coder.

The RA1/RA1' and RA1'/RA1'' functions only apply in A/Gb mode. In GERAN Iu mode the rate adaptation function RA1' applies instead of that as specified in clause 10.

The RA1'/RAA' function shall be used for channel codings TCH/F14.4, TCH/F28.8 and TCH/F43.2 if the AIUR is less than 64 kbit/s in A/Gb mode and if the AIUR is less than 56 kbit/s in GERAN Iu mode. It converts between the E-TRAU frame specified in 3GPP TS 48.060 and the input rate to the channel coder or the EDGE multiplexing function.

The RA1'/RAA'' function shall be used for channel codings TCH/F14.4 if the AIUR is equal to 64 kbit/s in A/Gb mode and if the AIUR is equal to 56 or 64 kbit/s in GERAN Iu mode. It converts between the 64 kbit/s data stream and the input rate to the channel coder.

A relay adaptation function is not needed for the channel coding TCH/F32.

### 8.1 Single slot rates

There are seven data rates (known as Radio Interface data rates) used for data transfer to the channel coder. These are 43,5 kbit/s (NT only), 32 kbit/s (T only), 29 kbit/s, 14,5 kbit/s, 12 kbit/s, 6 kbit/s and 3.6 kbit/s. In cases where EDGE channel codings TCH/F43.2 or TCH/F28.8 are used, the RA1'/RAA' function adapts the data stream to 14,5 kbit/s substreams as if multiple 14,5 kbit/s radio interface channels were used.

The 32 kbit/s user rate is identical to the 32 kbit/s intermediate rate. In this case the 32 kbit/s intermediate rate is directly mapped to the 32 kbit/s radio interface data rate.

The 8, 16 and 64 kbit/s intermediate rates and the 32 kbit/s intermediate rate with other than 32 kbit/s user rates are adapted to the radio interface data rates as follows:

AIUR	Intermediate rate	Radio interface rate
≤ 600 bit/s	8 kbit/s	3,6 kbit/s
1,2 kbit/s	8 kbit/s	3,6 kbit/s
2,4 kbit/s	8 kbit/s	3,6 kbit/s
4,8 kbit/s	8 kbit/s	6 kbit/s
9,6 kbit/s	16 kbit/s	12 kbit/s
14,4 kbit/s	32 kbit/s	14,5 kbit/s
28,8 kbit/s	64 kbit/s	29 kbit/s (Note 2)
43,2 kbit/s	(Note 1)	43,5 kbit/s (Note 2)

Note 1: AIUR only used in non-transparent configurations. There is no direct relationship between AIUR and Intermediate rate.

Note 2: The RA1'/RAA' function adapts the data stream to 14,5 kbit/s substreams as if multiple 14,5 kbit/s radio interface channels were used.

### 8.1.1 Radio interface rate of 14,5 kbit/s

The RA1'/RAA' function converts between the E-TRAU frame and the 290 bit blocks from the channel coder. The E-TRAU frames are defined in TS 48.060. The 290 bit blocks carry 288 data bits and the control bits M1 and M2 as specified in section 10.3.1 and 10.3.2.

### 8.1.2 Radio Interface rate of 12 kbit/s

In this case one modified ITU-T V.110 60 bit frame is received/sent from/to the radio interface every 5ms (see 3GPP TS 45.003). The RA1/RA1' function adds/subtracts the 17 bit synchronization pattern and the E1, E2 and E3 bits to/from each ITU-T V.110 80 bit frame as follows:

The modified ITU-T V.110 60 bits frame received/sent from/to the radio interface at 12 Kbit/s (Figure 5),

D1	D2	D3	D4	D5	D6	S1
D7	D8	D9	D10	D11	D12	X
D13	D14	D15	D16	D17	D18	S3
D19	D20	D21	D22	D23	D24	S4
E4	E5	E6	E7	D25	D26	D27
D28	D29	D30	S6	D31	D32	D33
D34	D35	D36	X	D37	D38	D39
D40	D41	D42	S8	D43	D44	D45
D46	D47	D48	S9			

is converted into the following a ITU-T V.110 80 bits frame at 16 Kbit/s (Figure 3):

0	0	0	0	0	0	0	0
1	D1	D2	D3	D4	D5	D6	S1
1	D7	D8	D9	D10	D11	D12	X
1	D13	D14	D15	D16	D17	D18	S3
1	D19	D20	D21	D22	D23	D24	S4
1	E1	E2	E3	E4	E5	E6	E7
1	D25	D26	D27	D28	D29	D30	S6
1	D31	D32	D33	D34	D35	D36	X
1	D37	D38	D39	D40	D41	D42	S8
1	D43	D44	D45	D46	D47	D48	S9

In the case of the non transparent services, bits S1, X, S3, S4, E4, E5, E6, E7, S6, X (second occurrence), S8, and S9 carry bits D'1, D'2, D'3, D'4, D'5, D'6, D'7, D'8, D'9, D'10, D'11, and D'12, respectively.

For a modified ITU-T V.110 60 bit frames received from the radio interface, the received D, S and X bits or D and D' bits are set to the same value as the transmitted bits. Bits E1, E2, E3 are set according to the user data rate as shown in figure 4 for the transparent services, or the RLP multiframe and DTX indication as per 3GPP TS 48.020 in the non transparent case.

For modified ITU-T V.110 60 bit frames transmitted over the radio interface, the received D, S, and X bits or D and D' are set to the same value as the transmitted bits. Bits E1, E2, E3 are discarded.

### 8.1.3 Radio Interface rate of 6 kbit/s

In this case one modified ITU-T V.110 60 bit frame is received/sent from/to the radio interface every 10 ms (see 3GPP TS 45.003). The RA1/RA1' function adds/subtracts the 17 bit synchronization pattern and the E1, E2 and E3 bits to/from each ITU-T V.110 80 bit frame as follows:

The modified ITU-T V.110 60 bits frame received/sent from/to the radio interface at 6 Kbit/s (Figure 6),

D1	D2	D3	D4	D5	D6	S1
D7	D8	D9	D10	D11	D12	X
D13	D14	D15	D16	D17	D18	S3
D19	D20	D21	D22	D23	D24	S4
E4	E5	E6	E7	D25	D26	D27
D28	D29	D30	S6	D31	D32	D33
D34	D35	D36	X	D37	D38	D39
D40	D41	D42	S8	D43	D44	D45
D46	D47	D48	S9			

is converted into the following a ITU-T V.110 80 bits frame at 8 Kbit/s (Figure 3):

0	0	0	0	0	0	0	0
1	D1	D2	D3	D4	D5	D6	S1
1	D7	D8	D9	D10	D11	D12	X
1	D13	D14	D15	D16	D17	D18	S3
1	D19	D20	D21	D22	D23	D24	S4
1	E1	E2	E3	E4	E5	E6	E7
1	D25	D26	D27	D28	D29	D30	S6
1	D31	D32	D33	D34	D35	D36	X
1	D37	D38	D39	D40	D41	D42	S8
1	D43	D44	D45	D46	D47	D48	S9

In the case of the non transparent services, bits S1, X, S3, S4, E4, E5, E6, E7, S6, X (second occurrence), S8, and S9 carry bits D'1, D'2, D'3, D'4, D'5, D'6, D'7, D'8, D'9, D'10, D'11, and D'12, respectively.

For a modified ITU-T V.110 60 bit frames received from the radio interface, the received D, S and X bits or D and D' bits are set to the same value as the transmitted bits. Bits E1, E2, E3 are set according to the user data rate as shown in figure 4 for the transparent services, or the RLP multiframe and DTX indication as per 3GPP TS 48.020 in the non transparent case.

For modified ITU-T V.110 60 bit frames transmitted over the radio interface, the received D, S, and X bits or D and D' bits are set to the same value as the transmitted bits. Bits E1, E2, E3 are discarded.

This process is identical to that used for the 12 kbit/s case except that the frame repetition rates are halved.

### 8.1.4 Radio Interface rate of 3,6 kbit/s (transparent services only)

In this case one modified ITU-T V.110 36 bit frame is received/sent from/to the radio interface every 10ms (see 3GPP TS 45.003 [5]). The RA1/RA1' function adds/subtracts the 17 bit synchronization pattern and the E1,E2 and E3 bits to/from each ITU-T V.110 80 bit frame as follows:

For the AIUR of 2,4 kbit/s the modified ITU-T V.110 36 bits frame received/sent from/to the radio interface at 3.6 kbit/s (Figure 7a),

D1	D2	D3	S1	D4	D5	D6	X
D7	D8	D9	S3	D10	D11	D12	S4
E4	E5	E6	E7	D13	D14	D15	S6
D16	D17	D18	X	D19	D20	D21	S8
D22	D23	D24	S9				

is converted into the following a ITU-T V.110 80 bits frame at 8 Kbit/s (Figure 7b):

0	0	0	0	0	0	0	0
1	D1	D1	D2	D2	D3	D3	S1
1	D4	D4	D5	D5	D6	D6	X
1	D7	D7	D8	D8	D9	D9	S3
1	D10	D10	D11	D11	D12	D12	S4
1	E1	E2	E3	E4	E5	E6	E7
1	D13	D13	D14	D14	D15	D15	S6
1	D16	D16	D17	D17	D18	D18	X
1	D19	D19	D20	D20	D21	D21	S8
1	D22	D22	D23	D23	D24	D24	S9

Figure 8 and 9 show the bit mappings for the AIUR of 1200 and 600 bit/s.

For modified ITU-T V.110 36 bit frames transmitted to the radio interface, E1, E2, E3 are discarded. For modified ITU-T V.110 36 bit frames received from the radio interface, E1, E2, E3 are set as shown in figure 4.

NOTE: The action to be taken in the case where two bits which should have the same value (e.g. bits noted D1) are received with different values is for further study.

### 8.1.5 Synchronisation

In GERAN Iu mode, the BSS shall perform the synchronisation towards the MS according to the procedures defined for the A/Gb mode in 3GPP TS 29.007 with the modification that the the indication of "physical connection established" is given on sending the message RAB ASSIGNMENT COMPLETE.

### 8.1.6 Idle frames

Whenever no data is received from the radio interface (e.g. frame stealing applies, layer 2 fill frames are received, etc.) idle frames shall be created. These are V.110 frames with frame alignment pattern according to ITU-T V.110 [11] and all data, status and E-bits set to binary "1".

## 8.2 Multislot rates

In multislot operation the transmission is performed using parallel substreams between the Split/Combine-functions.

### 8.2.1 AIURs up to 38,4 kbit/s using TCH/F9.6 and TCH/F4.8 channel codings

AIUR	Intermediate rate	Radio interface rate
9,6 kbit/s	16 kbit/s	2×6 kbit/s
14,4 kbit/s	32 kbit/s	2×12 or 3×6 kbit/s
19,2 kbit/s	32 kbit/s	2×12 or 4×6 kbit/s
28,8 kbit/s	64 kbit/s	3×12 kbit/s
38,4 kbit/s	64 kbit/s	4×12 kbit/s

In these cases, the data stream is mapped from 80-bit intermediate rate frames into modified frames of 60 bits for radio-interface transmission as specified in subclause 8.1 for 12 kbit/s and 6 kbit/s except for the following cases:

For AIURs 14,4 and 28,8 kbit/s using channel codings TCH/F4.8 and TCH/F9.6, respectively, four consecutive V.110 80-bit frames (Figure 12) are mapped onto three consecutive modified 60-bit V.110 (Figure 5 or 6) frames at the MS. The 4×36 data bits in the 80-bit frames are mapped onto the 3×48 data bits in the 60-bit frames. However, bits E4-E7 in the 80-bit frames are mapped onto the E4-E7 bits in the 60-bit frames when their value indicate either positive or negative compensation (NIC; See subclause 5.1.1). The E4-E7 bits that indicate 'No compensation' in the 80-bit frames need not be mapped onto the 60-bit frames. The S- and X-bits in every fourth 80-bit frame are not mapped onto the 60-bit frames. When radio interface rate of 2 × 12 kbit/s is used for carrying AIUR 14,4 kbit/s, padding is used in the 60-bit frames of the higher substream number (Subclause 11.6).

For substream numbering information, please refer to subclause 10 of the present document.

### 8.2.2 AIURs up to 64 kbit/s using TCH/F14.4 channel coding

AIUR	Intermediate rate/	Radio interface rate
28,8 kbit/s	64 kbit/s	2×14,5
38,4 kbit/s	64 kbit/s	3×14,5
48 kbit/s	64 kbit/s	3×14,5
56 kbit/s	64 kbit/s	4×14,5
64 kbit/s	64 kbit/s	5×14,5

For AIURs < 64 kbit/s in A/Gb mode and for AIURs < 56 kbit/s in GERAN Iu mode, the RA1'/RAA' function extracts the eight 36 data bit blocks in the E-TRAU frames and sends them through the substreams in data blocks containing eight 36-bit frames as described in subclause 10.3.

For AIUR of 64 kbit/s in A/Gb mode and for AIURs of 56 and 64 kbit/s, the RA1'/RAA' function sends the data bits in the 64 kbit/s data stream through the substreams in data blocks containing eight 36-bit frames as described in subclause 10.3. In GERAN Iu mode the data are provided in 640 bits size SDUs. For 56 kbit/s, the last bit of each octet is set to "1".

An M1/M2-bit pair is sent over the radio-interface along with each data block every 20 ms. These bits carry the multiframe, substream number, V.24 status, and NIC information as described in subclauses 10.3.1 and 10.3.2.

### 8.2.3 AIUR of 48 kbit/s; Intermediate rate of 64 kbit/s; Radio interface rate of 5 x 12 kbit/s

One modified ITU-T V.110 60 bit frame (Figure 5) is received/sent from/to a TCH/F every 5 ms (see 3GPP TS 45.003) resulting in an radio-interface rate of 12 kbit/s per channel.

One 60-bit radio-interface frame is converted into two ITU-T V.110 32-bit frames at 64 kbit/s (Figure 13):

1	D1	D2	D3	D4	D5	D6	S1
0	D7	D8	D9	D10	D11	D12	X
1	D13	D14	D15	D16	D17	D18	S3
1	D19	D20	D21	D22	D23	D24	S4

## 8.2.4 AIUR of 56 kbit/s; Intermediate rate of 64 kbit/s, Radio interface rate of $5 \times 12$ kbit/s

One modified ITU-T V.110 60 bit frame (Figure 10) is received/sent from/to the network every 5 ms (see 3GPP TS 45.003) resulting in a radio-interface rate of 12 kbit/s per channel.

A modified ITU-T V.110 60 bits radio-interface frame (Figure 10):

D1	D2	D3	D4	D5	D6	T1
D7	D8	D9	D10	D11	D12	T2
D13	D14	D15	D16	D17	D18	T3
D19	D20	D21	D22	D23	D24	T4
D25	D26	D27	D28	D29	D30	D31
D32	D33	D34	D35	D36	D37	D38
D39	D40	D41	D42	D43	D44	D45
D46	D47	D48	D49	D50	D51	D52
D53	D54	D55	D56			

NOTE: For information on the T-bits, please refer to subclause 11.2 of the present document.

is converted into an ITU-T V.110 64 bits frame at 64 kbit/s (Figure 14):

D1	D2	D3	D4	D5	D6	D7	1
D8	D9	D10	D11	D12	D13	D14	1
D15	D16	D17	D18	D19	D20	D21	1
D22	D23	D24	D25	D26	D27	D28	1
D29	D30	D31	D32	D33	D34	D35	1
D36	D37	D38	D39	D40	D41	D42	1
D43	D44	D45	D46	D47	D48	D49	1
D50	D51	D52	D53	D54	D55	D56	1

## 8.2.5 AIUR of 64 kbit/s; Radio interface rate of $6 \times 12$ kbit/s

One modified ITU-T V.110 60 bit frame (Figure 10) is received/sent from/to the network every 5 ms (see 3GPP TS 45.003) resulting in a radio-interface rate of 12 kbit/s per channel.

A modified ITU-T V.110 60 bits radio-interface frame (Figure 10):

D1	D2	D3	D4	D5	D6	T1
D7	D8	D9	D10	D11	D12	T2
D13	D14	D15	D16	D17	D18	T3
D19	D20	D21	D22	D23	D24	T4
D25	D26	D27	D28	D29	D30	D31
D32	D33	D34	D35	D36	D37	D38
D39	D40	D41	D42	D43	D44	D45
D46	D47	D48	D49	D50	D51	D52
D53	D54	D55	D56			

NOTE: For information on the T-bits, please refer to subclause 11.2 of the present document.

is converted as follows: The data bits are extracted from the 60-bit frames received from the network; six frames, one of which carries padding as explained in subclause 11.5, carry 320 bits of user data per 5 ms resulting in a 64 kbit/s user rate which is sent forward as such.

# 9 The EDGE multiplexing function

In EDGE configurations the number of channels across the radio interface and that of substreams do not necessarily match. In such cases a multiplexing function described below shall be used at MS and BTS (3GPP TS 48.020). These functions distribute data between the substreams and radio channels.

At the MS the multiplexing function multiplexes 14.5 kbit/s substreams — produced either by the combination of Split/Combine and RA1/RA1' or RA1' functions in the transparent case, or by the combination of Split/Combine and RLP functions in the non-transparent case — into the TCH/F28.8 or TCH/F43.2 EDGE radio interface channels.

In the case of transparent 56 kbit/s or 64 kbit/s operation, the multiplexing function maps the data stream into two EDGE TCH/F32.0 radio interface channels.

## 9.1 Data block distribution into the substreams by the Multiplexing function; TCH/F28.8 channel coding

The multiplexing function maps/extracts two 14.5 kbit/s substreams into/from a 29.0 kbit/s radio interface channel.

A radio interface data block for a TCH/F28.8 channel contains the bit sequence: M1, M2, 288 user data bits, M1, M2, and 288 user data bits, in other words, the block is a combination of two TCH/F14.4 radio interface data blocks. The two TCH/F14.4 blocks belong to two separate substreams. One 580-bit block is transmitted/received every 20 ms.

### a) Transparent services

In uplink, the multiplexing function maps one 290-bit block from each substream into every 580-bit TCH/F28.8 radio interface data block. Blocks from one stream always occupy the same half of the 580-bit radio interface data blocks.

In downlink, the multiplexing function demultiplexes the two substreams by extracting the two 290-bit blocks from the received 580-bit radio interface blocks; the 290-bit blocks belonging to one substream are carried in the same half of the 580-bit radio interface blocks.

### b) Non-transparent services

The multiplexing function works in the same way as in the transparent case, i.e. the multiplexing is based on the use of 290-bit blocks, which — in this case — contain halves of 576-bit RLP frames.

### 9.1.1 AIUR of 57.6 kbit/s; Radio interface rate of $2 \times 29.0$ kbit/s

Non-transparent 57.6 kbit/s radio interface user rate can be achieved by using a combination of two TCH/F28.8 channels across the radio interface. Two parallel multiplexing functions are applied; the operation of both of these is as described in section 9.1 above.

## 9.2 Data block distribution to the radio interface by the Multiplexing function; TCH/F32.0 channel coding

The multiplexing function divides the datastream into blocks of ten 64-bit V.110 frames (Figure 14) in case of the 56 kbit/s user rate or into blocks of 640 data bits in case of the 64 kbit/s user rate. These blocks are distributed cyclically into timeslots  $a$  ( $0 \leq a \leq 6$ ) and  $a+n$  ( $1 \leq a+n \leq 7$ ) in each TDMA-frame; in the data stream, data mapped into timeslot  $a$  precedes that mapped into slot  $a+n$ . The receiving Multiplexing function recombines overall data stream from radio-interface channels so that the data carried by timeslot  $a$  ( $0 \leq a \leq 6$ ) precedes the data carried by timeslot  $a+n$  ( $1 \leq a+n \leq 7$ ) of the same TDMA-frame.

### 9.2.1 AIUR of 56 kbit/s; Radio interface rate of $2 \times 32.0$ kbit/s

Two blocks of 10 64-bit V.110 frames (Figure 14) are sent/received every 20 ms over the radio interface.

No V.24 status or NIC-information is transferred in association with AIUR 56 kbit/s.

No substream numbering is needed as just one substream is used across a two-timeslot radio interface channel.

### 9.2.2 AIUR of 64 kbit/s; Radio interface rate of $2 \times 32.0$ kbit/s

Two blocks of 640 data bits are sent/received through the radio interface every 20 ms.

No V.24 status or NIC-information is transferred in association with AIUR 64 kbit/s.

No substream numbering is needed as just one substream is used across a two-timeslot radio interface channel.



## 9.3 Data block distribution into the substreams by the Multiplexing function; TCH/F43.2 channel coding

The multiplexing function maps/extracts three 14.5 kbit/s substreams into/from a 43.5 kbit/s radio interface channel.

A radio interface data block for a TCH/F43.2 channel is a combination of three TCH/F14.4 radio interface data blocks. The three TCH/F14.4 blocks belong to separate substreams. One 870-bit block is transmitted/received every 20 ms.

The TCH/F43.2 channel is used only in non-transparent operation. Therefore, the 290-bit blocks handled by the multiplexing function carry halves of 576-bit RLP frames.

In uplink, the multiplexing function maps one 290-bit block from each substream into every 870-bit TCH/F43.2 radio interface data block. Blocks from one stream always occupy the same third of the 870-bit radio interface data blocks.

In downlink, the multiplexing function demultiplexes the three substreams by extracting the 290-bit blocks from the received 870-bit radio interface blocks; the 290-bit blocks belonging to one substream are carried in the same third of the 870-bit radio interface blocks.

---

## 10 The RA1' Function

The RA1' function described below shall be used to adapt between the synchronous user data rates, or the output of the RA0 function and the radio interface data rates of 3.6, 6, 12, or 14.5 kb it/s. In cases where EDGE channel coding TCH/F28.8 is used, the RA1' function adapts the data stream to 14.5 kbit/s substreams as if multiple 14.5 kbit/s radio interface channels were used.

### 10.1 Void

### 10.2 TCH/F9.6 and TCH/F4.8 channel codings

Synchronous user rate	Total rate at the radio interface	DTE/DCE statuses	Air-interface bit frame structure	Single slot rate at the radio interface
≤ 2,4 kbit/s	3.6 kbit/s	X	36 bit (Figs. 7-9)	3.6 kbit/s
4,8 kbit/s	6 kbit/s	X	60 bit (Fig. 6)	6 kbit/s
9,6 kbit/s	12 kbit/s	X	60 bit (Fig. 5)	12 kbit/s or 6 kbit/s
14,4 kbit/s	24 kbit/s or 18 kbit/s	X	60 bit (Figs. 5 and 15)	12 kbit/s or 6 kbit/s (note)
19,2 kbit/s	24 kbit/s	X	60 bit (Fig. 5)	12 kbit/s or 6 kbit/s
28,8 kbit/s	36 kbit/s	X	60 bit (Fig. 5)	12 kbit/s
38,4 kbit/s	48 kbit/s	X	60 bit (Fig. 5)	12 kbit/s
48 kbit/s	60 kbit/s	X	60 bit (Fig. 5)	12 kbit/s
56 kbit/s	60 kbit/s		60 bit (Fig.10)	12 kbit/s
64 kbit/s	72 kbit/s		60 bit (Figs. 10 and 16)	12 kbit/s (note)

NOTE: Padding is used in frames making up the data substream of the highest substream number.

The modified ITU-T V.110 36 or 60 bit frame structures for each user rate are shown in figures 5 – 10, 15 and 16. The structure to apply is that for the partial user rate. The D bits are used to convey the user data and the S and X bits are used to convey channel control information according to 3GPP TS 27.001.

The E bits are used to convey the following information:

- i) User Data Rate - E1, E2, E3 (for single slot operation see Figure 4, and for multislot operation Figure 4 and subclause 11.6)
- ii) Network Independent Clocking - E4, E5, E6 (see subclause 10.2.1)
- iii) Multiframe Synchronisation - E7 (see subclause 10.2.1).

For description of the padding procedure, please refer to clause 11 of the present document.

## 10.2.1 Network Independent Clocking

Synchronous data signals received by the MT from the DTE at the MS or by IWF from the modem on the PSTN may not be synchronized to the PLMN. The following method shall be used to enable transfer of those data signals and the corresponding bit timing information via the V.110 frames. Such a situation would exist where the signals received from the modem at the IWF require its own clock or where the signals received from the DTE at the MS employs its own network independent clock. In any case, the frequency tolerance of the clocks involved is 100 ppm.

### 10.2.1.1 Multiframe Structure

The transmitting end of the A/Gb mode PLMN connection shall establish a multiframe structure utilizing bit E7 consisting of four frames by setting E7 in every fourth frame to binary 0. This structure is identical to the use of E7 in V.110 (and X.30) except that such a multiframe structure exists for all user data rates. This frame synchronization is achieved and maintained during the entire call so that corrections for the network independent clocking by the receiving end of the A/Gb mode PLMN connection can be easily recognized and applied based on the code words (in c1, c2, c3, c4 and c5) positioned in bits E4, E5 and E6 of two consecutive V.110 frames as illustrated in figure 1. Thus, the multiframe structure allows for one 5-bit code words to be transmitted every two V.110 frames for the purposes of network independent clocking. The two code-words may be different from each other within the multiframe shown in figure 1.

Frame	E4	E5	E6	E7
MF 0a	c1	c2	1	0
MF 1a	c3	c4	c5	1
MF 0b	c1	c2	1	1
MF 1b	c3	c4	c5	1

Figure 1: NIC Multiframe Structure

Once Multiframe synchronization is achieved, each code word is independently evaluated to determine the compensation needed, if any. The compensation is applied as explained in section 3.1.2 in V.110 frames MF 1a and MF 1b.

### 10.2.1.2 Encoding and compensation

The V.110 transmitter uses the following 5-bit code words, as shown in figure 2, to indicate the four possible states of compensation required for network independent clocking.

	c1	c2	c3	c4	c5
No compensation	1	1	1	1	1
Negative compensation	1	0	0	1	0
Positive compensation of a zero	0	1	0	0	1
Positive compensation of one	0	0	1	0	0

Figure 2: NIC Code Words

When negative compensation is indicated, one less user data bit than normal is transported in the affected frame (MF1a or MF1b). A negative compensation shall cause the receiver to delete the user data bit occupied by bit position D25, since the transmitter sets this to binary 1 and does not utilize this position for user data. At those user data rates where

the user data bit is repeated, all copies of D25 shall be discarded. In case of frames with 36 data bits, bit D19 is discarded instead.

When a positive compensation is indicated, one additional user data bit is transferred by means of the code word. At the receiver, a positive compensation causes a user data bit of binary value 0 or 1, as indicated by the code word, to be inserted between the user data bits carried in bit positions D24 and D25 (in MF 1a or MF 1b). In case of frames with 36 data bits, the insertion is done to between bits D18 and D19.

When no compensation is necessary, or when NIC is applied, the values of E4, E5, E6, E7, on the 4 multi frame scheme is:

Frame	E4	E5	E6	E7
MF 0a	1	1	1	0
MF 1a	1	1	1	1
MF 0b	1	1	1	1
MF 1b	1	1	1	1

When NIC is not applicable, the MS and the IWF shall disregard the received value of bits E4, E5, E6 and E7 in the data transmission phase.

NOTE: NIC is not applicable in the following cases:

- transparent asynchronous bearer services;
- the facsimile teleservices in the transparent mode;
- every transparent bearer services when interworking with an UDI Information Transfer Capability.

## 10.2.2 Synchronisation

Two interfaces are involved in the TAF regarding the need for data frame synchronisation, i.e. the TAF/air-interface and TAF/TE interface. For detailed definition of the synchronisation procedures refer to 3GPP TS 27.001.

## 10.2.3 Idle frames

Whenever no data is received from the radio interface (e.g. frame stealing applies, layer 2 fill frames are received, etc.) idle frames shall be sent to the DTE. These are V.110 frames with frame alignment pattern according to ITU-T recommendation. V.110 [11] and all data, status and E-bits set to binary "1".

## 10.3 TCH/F14.4 channel coding

Synchronous user rate	Total rate at the radio interface	DTE/DCE statuses	Air-interface bit frame structure	Single slot rate at the radio interface
14,4 kbit/s	14,5 kbit/s	X	36 bits, 290-bit block	14,5 kbit/s
28,8 kbit/s	29.0 kbit/s	X	36 bits, 290-bit block	14,5 kbit/s
38,4 kbit/s	43.5 kbit/s	X	36 bits, 290-bit block	14,5 kbit/s (note)
48 kbit/s	58.0 kbit/s	X	36 bits, 290-bit block	14,5 kbit/s (note)
56 kbit/s	58.0 kbit/s		36 bits, 290-bit block	14,5 kbit/s (note)
64 kbit/s	72.5 kbit/s		36 bits, 290-bit block	14,5 kbit/s (note)

NOTE: Padding used as specified for TCH/F14.4 channel coding in clause 11.

The format used for transferring a synchronous data stream over the radio-interface is a multiframe consisting of 31 data blocks. The RA1' function transfers the synchronous data stream into data blocks containing eight 36-bit frames as described in subclause 10.3.2. Each data block contains bits M1 and M2 followed by 288 user data bits sent/received over the radio-interface every 20 ms. The M1-bit carries a 31-bit PN-sequence used for aligning the multiframe(s), whereas the M2-bit carries substream numbering, V.24 status information, and NIC-codes as described in subclause 10.3.1. The status information carried by the M2-sequence(s) is interpreted as specified in 3GPP TS 27.001. When three

consecutive M2-bits carry a substream number, this is interpreted as specified in clause 11. Five consecutive M2-bits carrying NIC-information are interpreted according to subclause 10.3.1.

In multislot operation the transmission is performed using parallel substreams between the Split/Combine-functions.

### 10.3.1 Multiframe structure over the radio-interface

Bit M1 carries a 31-bit PN multiframe code 0000 1001 0110 0111 1100 0110 1110 101. One multiframe bit is transmitted every 20 ms per substream, which means that one whole multiframe consists of 248 36-bit frames.

Bit M2 carries V.24 circuit status information, network independent clocking (NIC) information and substream numbering as indicated in the following figure:

bit number	0 1 2 3	4 5 6 7	8 - 11	12- 15	16 - 19	20 - 23	24 - 27	28 - 30
M1:	0 0 0 0	1 0 0 1	0 1 1 0	0 1 1 1	1 1 0 0	0 1 1 0	1 1 1 0	1 0 1
M2:	### SB	SB X ##	# X SB SB	### SB	SB X ##	# X SB SB	NNNN	N SB SB

where ### = Substream number (multilink operation)

SB = the SB status bit

X = the X-status bit

NNNNN = Network independent clocking code

The information carried by the M2-sequences is read per substream; i.e. the substream number and a complete NIC-code are transferred through one substream.

A NIC-code is carried on as many substreams as is necessary to cover all NIC-compensations that have taken place. On channels where no NIC-compensation is carried, the N-bits are set to 'no compensation'. For the exact NIC-procedures, refer to subclause 10.3.3.

In the MS to Network direction the information carried by the M2-bit sequence is mapped in the following manner:

An M1/M2-bit pair is transmitted along each block of data containing eight modified V.110 36-bit frames. The three-bit #-sequence carries a number identifying each substream (multislot operation); the substreams are numbered 0,1,2 etc. The status- and NIC-information is mapped between the M2-sequence(s) and the V.110-frames. Bits SB and X are mapped to V.24 circuits as specified in 3GPP TS 27.001.

The SB-bit carries the V.110 SB-status information, and the X-bit the X-status information.

Five consecutive N-bits carrying an NIC-code in the M2-sequence indicate 'negative compensation' or 'positive compensation' if such a compensation is required. Otherwise 'no compensation' is indicated by the N-bits.

	N-bit 24 in M2-sequence	N-bit 25 in M2-sequence	N-bit 26 in M2-sequence	N-bit 27 in M2-sequence	N-bit 28 in M2-sequence
No compensation	1	1	1	1	1
Negative compensation	1	0	0	1	0
Positive compensation of a zero	0	1	0	0	1
Positive compensation of a one	0	0	1	0	0

#### The Network to MS direction:

The status-information is filtered as described in 3GPP TS 27.001. To change the SB- or X-status mode, it is required that at least two consecutive SB- or X-bits, respectively, carry the same value.

For NIC-procedure, refer to subclause 10.3.3.

## 10.3.2 Radio-interface data block for TCH/F14.4 channel coding

A radio-interface data block for a TCH/F14.4 channel consists of eight 36-bit data frames and bits M1 and M2 as shown in the following figure:

																	M1	M2		
1	D1	D2	D3	D4	D5	D6	D7	D8	D9	D10	D11	D12	D13	D14	D15	D16	D17	D18		
	D19	D20	D21	D22	D23	D24	D25	D26	D27	D28	D29	D30	D31	D32	D33	D34	D35	D36		
2	D1	D2	D3	D4	D5	D6	D7	D8	D9	D10	D11	D12	D13	D14	D15	D16	D17	D18		
	D19	D20	D21	D22	D23	D24	D25	D26	D27	D28	D29	D30	D31	D32	D33	D34	D35	D36		
3	D1	D2	D3	D4	D5	D6	D7	D8	D9	D10	D11	D12	D13	D14	D15	D16	D17	D18		
	D19	D20	D21	D22	D23	D24	D25	D26	D27	D28	D29	D30	D31	D32	D33	D34	D35	D36		
4	D1	D2	D3	D4	D5	D6	D7	D8	D9	D10	D11	D12	D13	D14	D15	D16	D17	D18		
	D19	D20	D21	D22	D23	D24	D25	D26	D27	D28	D29	D30	D31	D32	D33	D34	D35	D36		
5	D1	D2	D3	D4	D5	D6	D7	D8	D9	D10	D11	D12	D13	D14	D15	D16	D17	D18		
	D19	D20	D21	D22	D23	D24	D25	D26	D27	D28	D29	D30	D31	D32	D33	D34	D35	D36		
6	D1	D2	D3	D4	D5	D6	D7	D8	D9	D10	D11	D12	D13	D14	D15	D16	D17	D18		
	D19	D20	D21	D22	D23	D24	D25	D26	D27	D28	D29	D30	D31	D32	D33	D34	D35	D36		
7	D1	D2	D3	D4	D5	D6	D7	D8	D9	D10	D11	D12	D13	D14	D15	D16	D17	D18		
	D19	D20	D21	D22	D23	D24	D25	D26	D27	D28	D29	D30	D31	D32	D33	D34	D35	D36		
8	D1	D2	D3	D4	D5	D6	D7	D8	D9	D10	D11	D12	D13	D14	D15	D16	D17	D18		
	D19	D20	D21	D22	D23	D24	D25	D26	D27	D28	D29	D30	D31	D32	D33	D34	D35	D36		

The number on the left indicates the order of the data frames in the 290-bit block; the 36-bit frame in position one was received before that in position two etc. One such block is transmitted over the radio interface every 20 ms.

## 10.3.3 Network independent clocking

The data frames carrying an NIC-multiframe (subclause 10.2.1) indicating a positive or negative compensation are distributed into the substreams according to subclause 11.1.

In the following, 'a data bit position' means a non-padded bit position in the 290-bit radio interface blocks.

The NIC-codes are read per substream, i.e. the sequence of five N-bits in a substream carries one complete NIC-code.

In a 29 kbit/s radio interface channel the two halves of the 580-bit radio interface block correspond to substreams.

If NIC-compensation(s) take(s) place in the overall user data flow :

### 10.3.3.1. Negative compensation

#### a) From overall data stream to substreams

When only one substream is used and the data is mapped to the radio interface blocks, the 'extra null bit', which is set to '1', (subclause 10.2.1) is mapped to the first data bit position of the radio interface block which carries the fifth N-bit in the 31-block multiframe structure. The five N-bits encode 'negative compensation' as described in clause 10.2.1.

If more than one substream is used, and more than one negative compensation should be performed the 'extra null bit' is mapped to the first data bit position of the radio interface block which carries the fifth N-bit in the 31-block multiframe structure in as many substreams as necessary to perform all compensations. In those substreams where no compensation is needed the N-bits are set to 'no compensation'.

#### b) From substreams to overall data stream

When a radio interface block carrying the fifth bit of an NIC-code indicating negative compensation is received, the receiver discards the first data bit of the block.

### 10.3.3.2 Positive compensation

#### a) From overall data stream to substreams

An NIC-code indicating positive compensation means that the data bit from the overall data stream preceding the bit mapped into the first position of the data block conveying the second N-bit is carried encoded by the five N-bits.

If more than one substream is used, and if more than one compensation has taken place in the overall data stream, more than one substream carries a NIC-code indicating 'positive compensation'. In those substreams where no NIC-compensation is needed the N-bits indicate 'no compensation'.

b) From substreams to overall data stream

When an NIC-code indicating positive compensation is received, an extra '0' or '1' — depending on whether a compensation of a '0' or '1' is indicated — is mapped to before the first data bit position of the block with which the second bit of the NIC-code is associated.

---

## 11 The Split/Combine and Padding-functions

The split/combine and padding functions shall be used with multislot connections as described below. The Split/Combine function splits/recombines the overall data stream to/from the substreams. The Padding function inserts filling into one of the substreams in cases where the total capacity of the substreams is larger than necessary to achieve the required AIUR.

### 11.1 Data frame distribution into the substreams/channels by the Split/Combine function

#### 11.1.1 Data frame distribution into the substreams/channels by the Split/Combine function (TCH/F9.6 and TCH/F4.8 channel codings)

- a) In the transparent case the Split/Combine-function distributes the V.110-frames into the substreams and recombines the overall data stream from the substreams according to the following rules:

In the overall data stream

- 1) the frame in position  $p$  in substream  $q$  precedes the frame in position  $p$  in substream  $q+1$ ,  $0 \leq q < n-1$
- 2) the frame in position  $p$  in substream  $n-1$  precedes the frame in position  $p+1$  in substream  $0$ ;

where in the rules above  $n$  is the number of substreams.

- b) In the non-transparent case the Split/Combine-function distributes the RLP-frames — or the four V.110-frames making up an RLP-frame (Reference: 3GPP TS 48.020, Subclause 15.1) — into channels so that one whole RLP-frame is carried through one channel. Furthermore the RLP-frames are distributed into the available channels so that the resulting delay in the overall data stream is kept as small as possible. The receiving Split/Combine-function recombines the overall data stream according to the inherent RLP-frame numbering, i.e. the N(S)-numbers in the RLP-frame header (3GPP TS 24.022).

#### 11.1.2 Data block distribution into the substreams by the Split/Combine function (TCH/F14.4 channel coding)

- a) Transparent services

The Split/Combine-function distributes the user data carried in the 290-bit blocks (Refer to subclause 10.3.2) into the substreams and recombines the overall data stream from the substreams according to the following rules:

In the overall data stream:

- 1) the data block in position  $m$  of multiframe in substream  $q$  precedes the data block in position  $m$  of multiframe in substream  $q+1$ ,  $0 \leq q < n-1$ ,  $0 \leq m \leq 30$ .

- 2) the data block in position  $m$  of multiframe in substream  $n-1$  precedes the data block in position  $m+1$  of multiframe in substream 0;

where in the rules above  $n$  is the number of substreams.

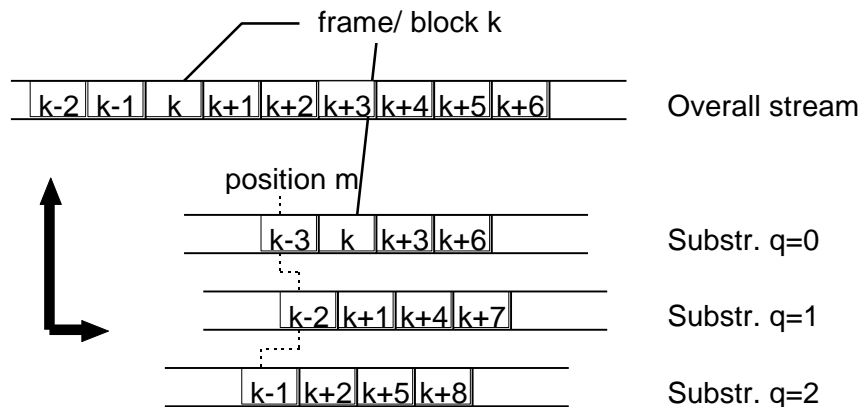

**Figure 2a: Distribution of data frames or data blocks into the substreams in transparent operation**

b) Non-transparent services

In the non-transparent operation the Split/Combine-function distributes the RLP-frames into substreams so that one whole RLP-frame is carried through one substream. This means that the two 290-bit air-interface blocks carrying one RLP-frame are transmitted through the same substream. Furthermore the RLP-frames are distributed into the available substreams so that the resulting delay in the overall data stream is kept as small as possible. The receiving Split/Combine-function recombines the overall data stream according to the inherent RLP-frame numbering, i.e. the  $N(S)$ -numbers in the RLP-frame header (3GPP TS 24.022).

## 11.2 Substream numbering in transparent operation

### 11.2.1 Substream numbering for TCH/F4.8 and TCH/F9.6 channel codings

In transparent multislot data configurations of more than one TCH/F the parallel data substreams between the Split/Combine-functions carry inband substream numbering. The status bits  $S1$ ,  $S3$ , and the  $X$ -bit between data bits  $D12$  and  $D13$  (Figures 5 and 6) are used for transferring this substream numbering information ( $S1$  is the MSB and  $S3$  the LSB). The substreams are numbered 0, 1, 2, 3 etc. regardless of the physical channels through which the substreams are transmitted. The highest substream number is one less than the number of physical channels in use at a given time; i.e. the numbering cycle changes when physical channels are either added to or removed from a connection.

The  $S4$ -bit is used for frame synchronisation between the parallel substreams. This bit follows a 31-bit PN-sequence of 0000 1001 0110 0111 1100 0110 1110 101. This thirty one bit sequence is used for substream resynchronisation in cases where delay has occurred on one or more substream(s); the position of a frame in a substream can be determined modulo 31 by the values of the  $S4$ -bit in a sequence of 5 consecutive frames including the frame in question. Provided that the relative delay between substreams is less than 75 ms (i.e. less than a 15-frame displacement), this and the frame distribution rules given in subclause 11.1 are sufficient to determine the correct order of the frames.

Bits  $S6$ ,  $S8$ ,  $S9$ , and the other  $X$ -bit are used for conveying channel control information according to the relevant terminal adapter function specification.

These rules apply to all multislot data AIURs up to and including 48 kbit/s. When the received 48 kbit/s AIUR is converted into 64 kbit/s rate, the bits extracted from the 60-bit radio interface frames (Figure 5) are mapped into the 32-bit frame format of Figure 13. Here the values for the status bits  $S1$ ,  $X$ ,  $S3$ , and  $S4$  in the 32-bit frame shall be derived from status bits  $S6$ ,  $X$ ,  $S8$ , and  $S9$  in the radio-interface frame because status bits  $S1$ ,  $X$ ,  $S3$ , and  $S4$  in the upper right hand corner of the 60-bit frame have been used for data substream numbering as described above.

In the 11,2 kbit/s frames used for AIURs 56 and 64 kbit/s (Figure 10) the  $T1$ ,  $T2$ ,  $T3$  ( $T1$  the MSB and  $T3$  the LSB) are used for carrying the substream numbering as status bits  $S1$ ,  $X$ , and  $S3$  do according to the definition given in the first

paragraph of subclause 10.1. Bit T4 is used for carrying the substream synchronisation sequence just as status bit S4 does in the description given in the second paragraph of this subclause.

## 11.2.2 Substream numbering for TCH/F14.4 and TCH/F28.8 channel codings

Bit M1 carries the multiframe sequence 0000 1001 0110 0111 1100 0110 1110 101. The number of the substream in which a multiframe is sent is carried four times in a 31-bit period of the M2-sequence. In the three-bit number code the bit in the lowest bit position is the MSB (See table in subclause 10.3.1).

## 11.3 Substream Synchronisation

Two interfaces are involved in the TAF regarding the need for the data frame synchronisation, i.e the TAF/multichannel interface and the TAF/TE interface.

The Split/Combine function is responsible for controlling the synchronisation and resynchronisation procedures as described in 3GPP TS 27.001.

## 11.4 Void

## 11.5 Padding Functions

### 11.5.1 Padding for TCH/F9.6 and TCH/F4.8

When the required AIUR is not a multiple of the rates supported by TCH/F4.8 or TCH/F9.6, padding is used for producing the required AIUR.

To achieve the required AIUR the data bits are distributed across the substreams 1 to n as follows:

- Substream(s) 1 (to n-1) carry multiples of the rate supported by the channel coding used.
- Substream n carries the remaining amount of data bits required to achieve the required AIUR. The remainder of data stream n carries padding bits set to binary value '1'.

#### 11.5.1.1 Padding for AIUR 14,4 kbit/s:

The frame of the lower substream number carries full 9,6 kbit/s. The frame of the higher substream number carries 4,8 kbit/s of user data in bit positions D1-D24 while bit positions D25-D48 are inserted with binary "1"s. (Figure 15)

#### 11.5.1.2 Padding for AIUR 64 kbit/s:

The frames numbered 1-5 carry full 11,2 kbit/s. Frame number 6 carries 8,0 kbit/s of user data in bit positions D1-D40 while bit positions D41-D56 are inserted with binary "1"s. (Figure 16)

### 11.5.2 Padding for TCH/F14.4 channel coding

#### 11.5.2.1 Padding for AIURs up to 38,4 kbit/s

Padding is not necessary for AIURs 14,4 and 28,8 kbit/s.

For AIUR 38,4 kbit/s the 290-bit blocks in the substreams of the lower substream numbers carry 288 user data bits while the 290-bit blocks in the substream of the highest substream number carries 192 user data bits; this means that five of the eight 36-bit frames making up the block carry 36 user data bits whereas the sixth frame carries 12 user data bits ( $5 \times 36 + 12$ ). Frames seven, eight, and the rest of the sixth frame are padded with '1's.



### 11.5.2.2 Padding for AIURs of 48 kbit/s

The 290-bit blocks in the highest numbered substream carry 96 user data bits ( $2 \times 36 + 24$ ).

The M2-bit sequences are used, for the applicable parts, as described in subclauses 10.3.1.1.

### 11.5.2.3 Padding for AIURs of 56 kbit/s

The 290-bit blocks in the highest numbered substream carry 256 user data bits ( $7 \times 36 + 4$ ).

The M2-bit sequences are used, for the applicable parts, as described in subclauses 10.3.1.1.

### 11.5.2.4 Padding for AIURs of 64 kbit/s

The 290-bit blocks in the highest numbered substream carry 128 user data bits ( $3 \times 36 + 20$ ).

The M2-bit sequences are used, for the applicable parts, as described in subclauses 10.3.1.1.

## 11.6 Handling of the E1-E3 bits in multislot operation

Between the Split / Combine functions the substreams carry the code associated with the substream rate as defined in Figure 4. When the substreams are combined the code is set to correspond to the overall AIUR according to Figure 4.

---

## 12 Support of Non-Transparent Bearer Services

In the case of non-transparent services, the RA1' function shall provide access to the 12 and 6 kbit/s radio interface data rates as described below. (Alignment of RLP frames with the four TDMA slots makes it physically impossible to provide 3,6 kbit/s.) The RA1' function is not applied in case of TCH/F14.4, TCH/F28.8 and TCH/F43.2 channel codings.

Air interface user rate	Radio interface rate
4,8 kbit/s	6 kbit/s
9,6 kbit/s	12 kbit/s or $2 \times 6$ kbit/s
14,4 kbit/s	14,5 kbit/s or $2 \times 12$ kbit/s or $3 \times 6$ kbit/s
19,2 kbit/s	$2 \times 12$ kbit/s or $4 \times 6$ kbit/s
28,8 kbit/s	29 kbit/s or $2 \times 14,5$ kbit/s or $3 \times 12$ kbit/s
38,4 kbit/s	$3 \times 14,5$ kbit/s or $4 \times 12$ kbit/s
43,2 kbit/s	43,5 kbit/s or $3 \times 14,5$ kbit/s
57,6 kbit/s	$2 \times 29$ kbit/s or $4 \times 14,5$ kbit/s

### 12.1 Support of non-transparent operation for TCH/F9.6 and TCH/F4.8 channel codings

This access results in the use of a modified ITU-T V.110 60 bit frame for non-transparent services (figure 11). In this case, the RA1' function also provides for alignment of four modified ITU-T V.110 60 bit frames sent on the same radio slot corresponding with each complete 240 bit frame to be encoded by the radio subsystem as a single unit (see 3GPP TS 45.003). The difference between the non-transparent 60 bit frame and the 60 bit frame for the transparent service is that the bit positions used for status in a transparent frame are used to carry data (designated as D' bits in figure 11).

NOTE: The status bits SA, SB, and the X bit are embedded in the L2R-PDU frames (see 3GPP TS 27.001, and 27.002).

The first bit of each RLP frame to be transmitted corresponds to the first bit (D1) of the first 60 bit frame in a four frame sequence and the last bit corresponds to the last bit (D'12) of the last 60 bit frame in a four frame sequence. Each 60 bit frame is filled from left to right starting at D1 (see figure 11).

The radio subsystem provides for the synchronous transmission and reception of 240 bit RLP frames through a connection consisting of up to four TCH/Fs. An RLP-frame is received/sent from/to a particular radio channel every 20 ms (12 kbit/s radio interface rate) or every 40 ms (6 kbit/s radio interface rate) irrespective of the user rate.

The request to use 6 kbit/s radio interface rate on a Full Rate Channel is indicated in the BC-IE by setting the NIRR bit to 6 kbit/s (Negotiation procedure see 3GPP TS 27.001) and selecting a Full Rate Channel and Non-Transparent service. If the entity receiving the BC-IE is unable to support this request then the 12 kbit/s radio interface rate shall be provided automatically.

Occasions may arise when there is no RLP frame ready to be transmitted. In this case a frame of 240 zeroes are transmitted. This is discarded by the distant RLP function, due to FCS failure, but allows physical link synchronization to be maintained between the MS and the MSC.

In the case of an asymmetric connection the BTS shall send V110 idle frames towards the MSC on the channels which are unused in the direction from the MS towards the MSC. This ensures that the IWF does not interpret V110 frames which are not originated from the MS as complete RLP frames.

## 12.2 Support of non-transparent operation for TCH/F14.4 channel coding

In 14,4 kbit/s channel 576-bit RLP-frames shall be used as described below.

The RA1' function is not applied in this case. Instead the RLP-, or in multislot operation the Split/Combine- function, handles the 290-bit data blocks received/sent from/to the network. The M1- bit is used for indicating the RLP-frame halves: in the first half M1= 0 and in the second half M1=1. Bit M2 is used for DTX- indication between the BSS and MSC as described in 3GPP TS 48.020

In cases where no RLP-frame is ready to be transmitted, a sequence of 576 '1's is transmitted. This frame is discarded by the distant RLP-function due to FCS failure.

In the case of an asymmetric connection the BTS shall send idle frames towards the IWF on the channels which are unused in the direction from the MS towards the MSC, as specified in 3GPP TS 08.60. This ensures that the IWF does not interpret sequences of frames which are not originated from the MS as complete RLP frames.

## 12.3 Support of non-transparent operation for TCH/F28.8 channel coding

In a 28.8 kbit/s channel, 576-bit RLP-frames shall be used as described below. The 576-bit RLP-frames shall be mapped into the 580-bit radio interface blocks as described in section 9.1.

The RA1' function is not applied in this case. Instead, RLP handles the 580-bit data blocks received/sent from/to the Split/Combine function. The M1- bits are used for indicating RLP-frame halves. The M2-bits are used for DTX- indication between the BSS and MSC as described in 3GPP TS 48.020.

In cases where no RLP-frame is ready to be transmitted, a sequence of 576 '1's is transmitted. This frame is discarded by the distant RLP-function due to FCS failure.

## 12.4 Support of non-transparent operation for TCH/F43.2 channel coding

In a 43.2 kbit/s channel 576-bit RLP-frames shall be used as described below. The 576-bit RLP-frames shall be mapped into 870-bit radio interface blocks as described in section 9.3.

The RA1' function is not applied in this case. Instead, RLP handles the 580-bit data blocks received/sent from/to the Split/Combine function. The M1- bits are used for indicating RLP-frame halves. The M2-bits are used for DTX- indication between the BSS and MSC as described in 3GPP TS 48.020.

In cases where no RLP-frame is ready to be transmitted, a sequence of 576 '1's is transmitted. This frame is discarded by the distant RLP-function due to FCS failure.

# 13 Figures on Frame structures

Octet No.	Bit number							
	1	2	3	4	5	6	7	8
0	0	0	0	0	0	0	0	0
1	1	D1	D2	D3	D4	D5	D6	S1
2	1	D7	D8	D9	D10	D11	D12	X
3	1	D13	D14	D15	D16	D17	D18	S3
4	1	D19	D20	D21	D22	D23	D24	S4
5	1	E1	E2	E3	E4	E5	E6	E7
6	1	D25	D26	D27	D28	D29	D30	S6
7	1	D31	D32	D33	D34	D35	D36	X
8	1	D37	D38	D39	D40	D41	D42	S8
9	1	D43	D44	D45	D46	D47	D48	S9

Figure 3: The ITU-T V.110 80 bit RA1 frame structure

Intermediate Data Rate				E1	E2	E3	Note
8 kbit/s	16 kbit/s	32 kb/s	64 kb/s				
600				1	0	0	Note
1200				0	1	0	
2400				1	1	0	
4800	9600	19200	38400	0	1	1	
		14400	28800	1	0	1	

NOTE: The 300 bit/s user data rate is carried on the 600 bit/s synchronous stream by adding stop elements, see subclause 4.1.

Figure 4: Coding of data rates

D1	D2	D3	D4	D5	D6	S1
D7	D8	D9	D10	D11	D12	X
D13	D14	D15	D16	D17	D18	S3
D19	D20	D21	D22	D23	D24	S4
E4	E5	E6	E7	D25	D26	D27
D28	D29	D30	S6	D31	D32	D33
D34	D35	D36	X	D37	D38	D39
D40	D41	D42	S8	D43	D44	D45
D46	D47	D48	S9			

Figure 5: Modified ITU-T V.110 60 bit frame for 9,6 kbit/s transparent data

D1	D2	D3	D4	D5	D6	S1
D7	D8	D9	D10	D11	D12	X
D13	D14	D15	D16	D17	D18	S3
D19	D20	D21	D22	D23	D24	S4
E4	E5	E6	E7	D25	D26	D27
D28	D29	D30	S6	D31	D32	D33
D34	D35	D36	X	D37	D38	D39
D40	D41	D42	S8	D43	D44	D45
D46	D47	D48	S9			

Figure 6: Modified ITU-T V.110 60 bit frame for 4,8. kbit/s transparent data

a)

D1	D2	D3	S1	D4	D5	D6	X
D7	D8	D9	S3	D10	D11	D12	S4
E4	E5	E6	E7	D13	D14	D15	S6
D16	D17	D18	X	D19	D20	D21	S8
D22	D23	D24	S9				

b)

0	0	0	0	0	0	0	0
1	D1	D1	D2	D2	D3	D3	S1
1	D4	D4	D5	D5	D6	D6	X
1	D7	D7	D8	D8	D9	D9	S3
1	D10	D10	D11	D11	D12	D12	S4
1	1	1	0	E4	E5	E6	E7
1	D13	D13	D14	D14	D15	D15	S6
1	D16	D16	D17	D17	D18	D18	X
1	D19	D19	D20	D20	D21	D21	S8
1	D22	D22	D23	D23	D24	D24	S9

**Figure 7: a) Modified ITU-T V.110 36 bit frame for 2,4 kbit/s transparent data and b) the corresponding intermediate rate frame at 8 kbit/s**

a)

D1	D1	D2	S1	D2	D3	D3	X
D4	D4	D5	S3	D5	D6	D6	S4
E4	E5	E6	E7	D7	D7	D8	S6
D8	D9	D9	X	D10	D10	D11	S8
D11	D12	D12	S9				

b)

0	0	0	0	0	0	0	0
1	D1	D1	D1	D1	D2	D2	S1
1	D2	D2	D3	D3	D3	D3	X
1	D4	D4	D4	D4	D5	D5	S3
1	D5	D5	D6	D6	D6	D6	S4
1	0	1	0	E4	E5	E6	E7
1	D7	D7	D7	D7	D8	D8	S6
1	D8	D8	D9	D9	D9	D9	X
1	D10	D10	D10	D10	D11	D11	S8
1	D11	D11	D12	D12	D12	D12	S9

**Figure 8: a) Modified ITU-T V.110 36 bit frame for 1,2 kbit/s transparent data and b) the corresponding intermediate rate frame at 8 kbit/s**

a)

D1	D1	D1	S1	D1	D2	D2	X
D2	D2	D3	S3	D3	D3	D3	S4
E4	E5	E6	E7	D4	D4	D4	S6
D4	D5	D5	X	D5	D5	D6	S8
D6	D6	D6	S9				

NOTE: The 300 bit/s user data rate is carried on the 600 bit/s synchronous stream by adding stop elements, see subclause 4.1.

b)

0	0	0	0	0	0	0	0
1	D1	D1	D1	D1	D1	D1	S1
1	D1	D1	D2	D2	D2	D2	X
1	D2	D2	D2	D2	D3	D3	S3
1	D3	D3	D3	D3	D3	D3	S4
1	1	0	0	E4	E5	E6	E7 (note)
1	D4	D4	D4	D4	D4	D4	S6
1	D4	D4	D5	D5	D5	D5	X
1	D5	D5	D5	D5	D6	D6	S8
1	D6	D6	D6	D6	D6	D6	S9

NOTE: In order to maintain compatibility with Recommendation X.30 (I.461), for the 600 bit/s user rate bit E7 is coded to enable the 4×80 bit multiframe synchronisation. To this end, E7 in the fourth 80 bit frame is set to binary '0'. See Table 6 of ITU-T Recommendation V.110(09/92).

**Figure 9: a) Modified ITU-T V.110 36 bit frame for 600 bit/s transparent data and b) the corresponding intermediate rate frame at 8 kbit/s**

D1	D2	D3	D4	D5	D6	T1
D7	D8	D9	D10	D11	D12	T2
D13	D14	D15	D16	D17	D18	T3
D19	D20	D21	D22	D23	D24	T4
D25	D26	D27	D28	D29	D30	D31
D32	D33	D34	D35	D36	D37	D38
D39	D40	D41	D42	D43	D44	D45
D46	D47	D48	D49	D50	D51	D52
D53	D54	D55	D56			

**Figure 10: Modified ITU-T V.110 60 bit frame for 11,2 kbit/s partial rate**

D1	D2	D3	D4	D5	D6	D'1
D7	D8	D9	D10	D11	D12	D'2
D13	D14	D15	D16	D17	D18	D'3
D19	D20	D21	D22	D23	D24	D'4
D'5	D'6	D'7	D'8	D25	D26	D27
D28	D29	D30	D'9	D31	D32	D33
D34	D35	D36	D'10	D37	D38	D39
D40	D41	D42	D'11	D43	D44	D45
D46	D47	D48	D'12			

**Figure 11: Modified ITU-T V.110 60 bit frame for non-transparent data**

0	0	0	0	0	0	0	0
1	D1	D2	D3	D4	D5	D6	S1
1	D7	D8	D9	D10	F	F	X
1	D11	D12	F	F	D13	D14	S3
1	F	F	D15	D16	D17	D18	S4
1	1	0	1	E4	E5	E6	E7
1	D19	D20	D21	D22	D23	D24	S6
1	D25	D26	D27	D28	F	F	X
1	D29	D30	F	F	D31	D32	S8
1	F	F	D33	D34	D35	D36	S9

F = Fill bits, which are set to 1.

**Figure 12: The ITU-T V.110 80 bit frame for 3.6 kbit/s transparent data (8 kbit/s intermediate rate)**

1	D1	D2	D3	D4	D5	D6	S1
0	D7	D8	D9	D10	D11	D12	X
1	D13	D14	D15	D16	D17	D18	S3
1	D19	D20	D21	D22	D23	D24	S4

**Figure 13: The ITU-T V.110 32 bit 48 kbit/s frame structure (64 kbit/s intermediate rate)**

D1	D2	D3	D4	D5	D6	D7	1
D8	D9	D10	D11	D12	D13	D14	1
D15	D16	D17	D18	D19	D20	D21	1
D22	D23	D24	D25	D26	D27	D28	1
D29	D30	D31	D32	D33	D34	D35	1
D36	D37	D38	D39	D40	D41	D42	1
D43	D44	D45	D46	D47	D48	D49	1
D50	D51	D52	D53	D54	D55	D56	1

**Figure 14: The ITU-T V.110 64 bit 56 kbit/s frame structure (64 kbit/s intermediate rate, option without status bits)**

D1	D2	D3	D4	D5	D6	S1
D7	D8	D9	D10	D11	D12	X
D13	D14	D15	D16	D17	D18	S3
D19	D20	D21	D22	D23	D24	S4
E4	E5	E6	E7	1	1	1
1	1	1	S6	1	1	1
1	1	1	X	1	1	1
1	1	1	S8	1	1	1
1	1	1	S9			

**Figure 15: Modified ITU-T V.110 60 bit frame for a padded 9,6 kbit/s transparent data frame carrying 4,8 kbit/s with padding**

D1	D2	D3	D4	D5	D6	T1
D7	D8	D9	D10	D11	D12	T2
D13	D14	D15	D16	D17	D18	T3
D19	D20	D21	D22	D23	D24	T4
D25	D26	D27	D28	D29	D30	D31
D32	D33	D34	D35	D36	D37	D38
D39	D40	1	1	1	1	1
1	1	1	1	1	1	1
1	1	1	1			

**Figure 16: Modified ITU-T V.110 60 bit frame for a padded 11,2 kbit/s transparent data frame carrying 8.0 kbit/s with padding**

D1	D2	D3	D4	D5	D6
D7	D8	D9	D10	D11	D12
D13	D14	D15	D16	D17	D18
D19	D20	D21	D22	D23	D24
D25	D26	D27	D28	D29	D30
D31	D32	D33	D34	D35	D36

**Figure 17: Modified ITU-T V.110 36-bit frame received/sent from/to the network at 14,4 kbit/s**

# Annex A (Informative): Stacks of rate adaptation

## A.1 Stacks of rate adaptation for 9,6/4,8 kbit/s single slot operation

For transparent data services, the following stacks of rate adaptation are possible:

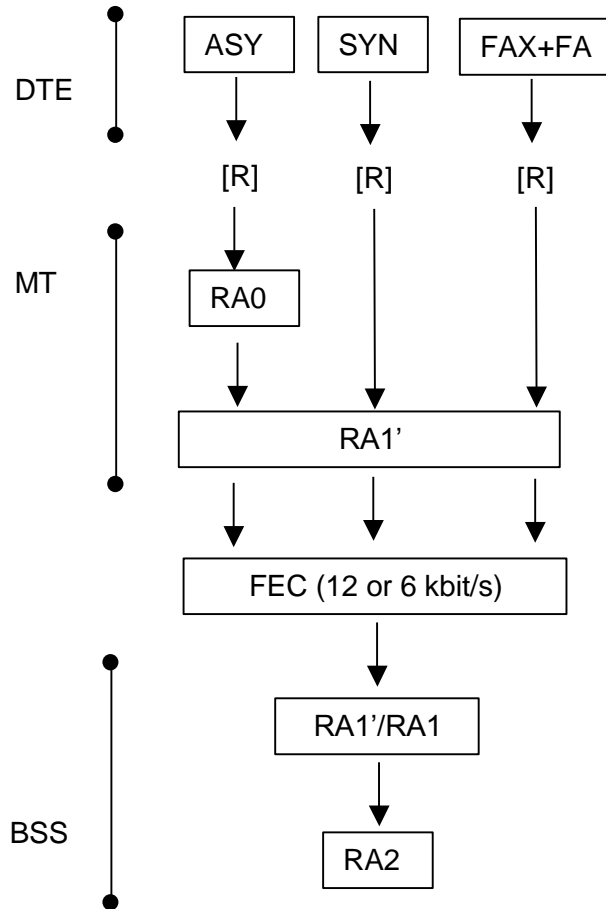



For the non-transparent services, the following stacks of rate adaptation and functions are possible:

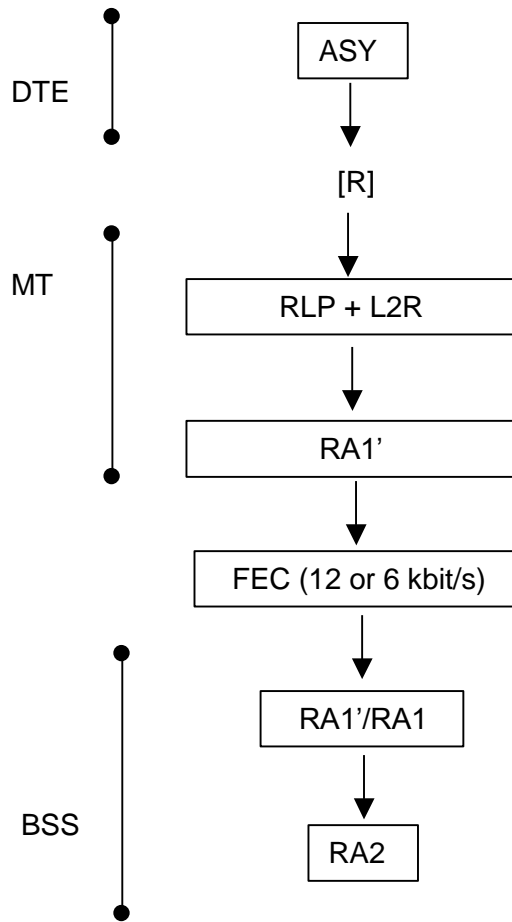

## A.2 Stacks of rate adaptation for 14,4 kbit/s single slot operation

For transparent data services, the following stacks of rate adaptation are possible:

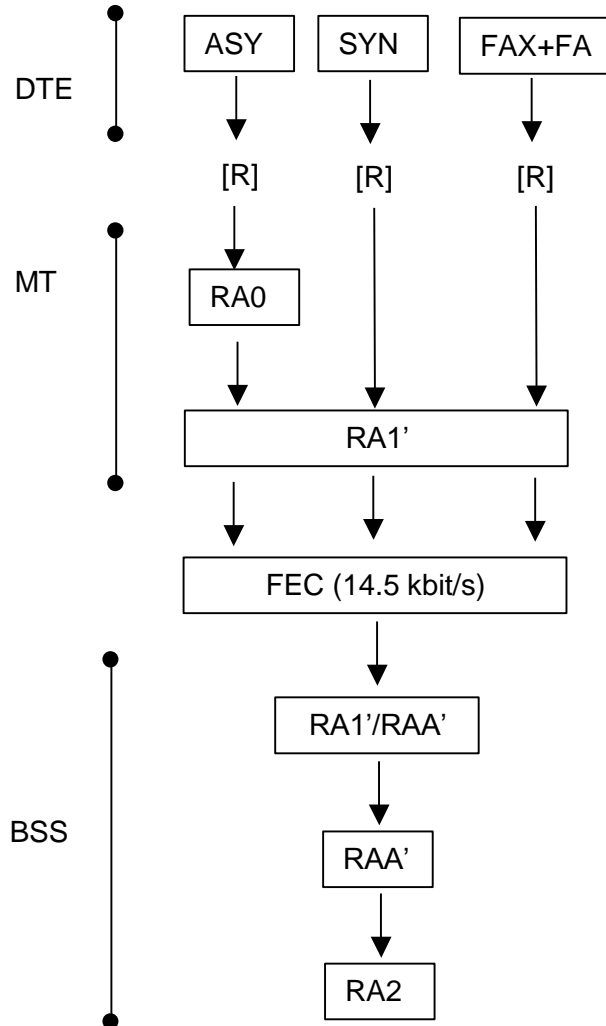

For the non-transparent services, the following stacks of rate adaptation and functions are possible:

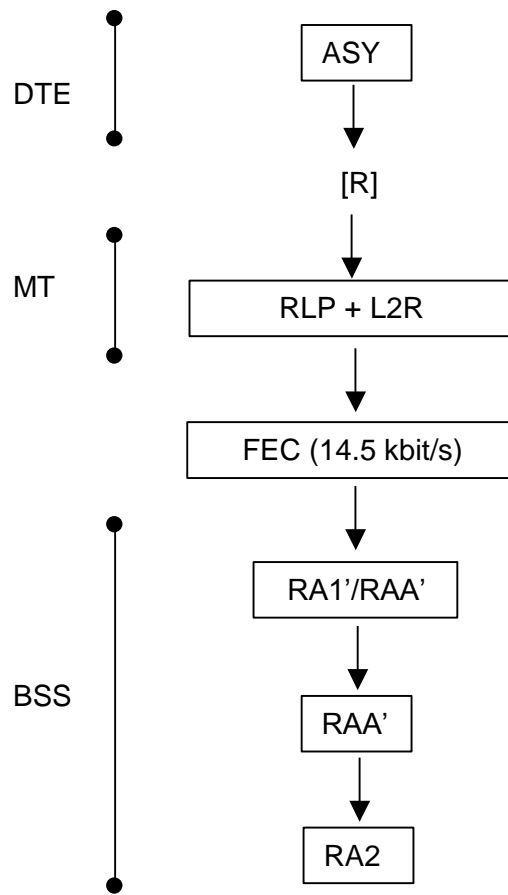

## A.3 Stacks of rate adaptation for 9,6/4,8 kbit/s multi slot operation

For transparent data services, the following stacks of rate adaptation are possible:

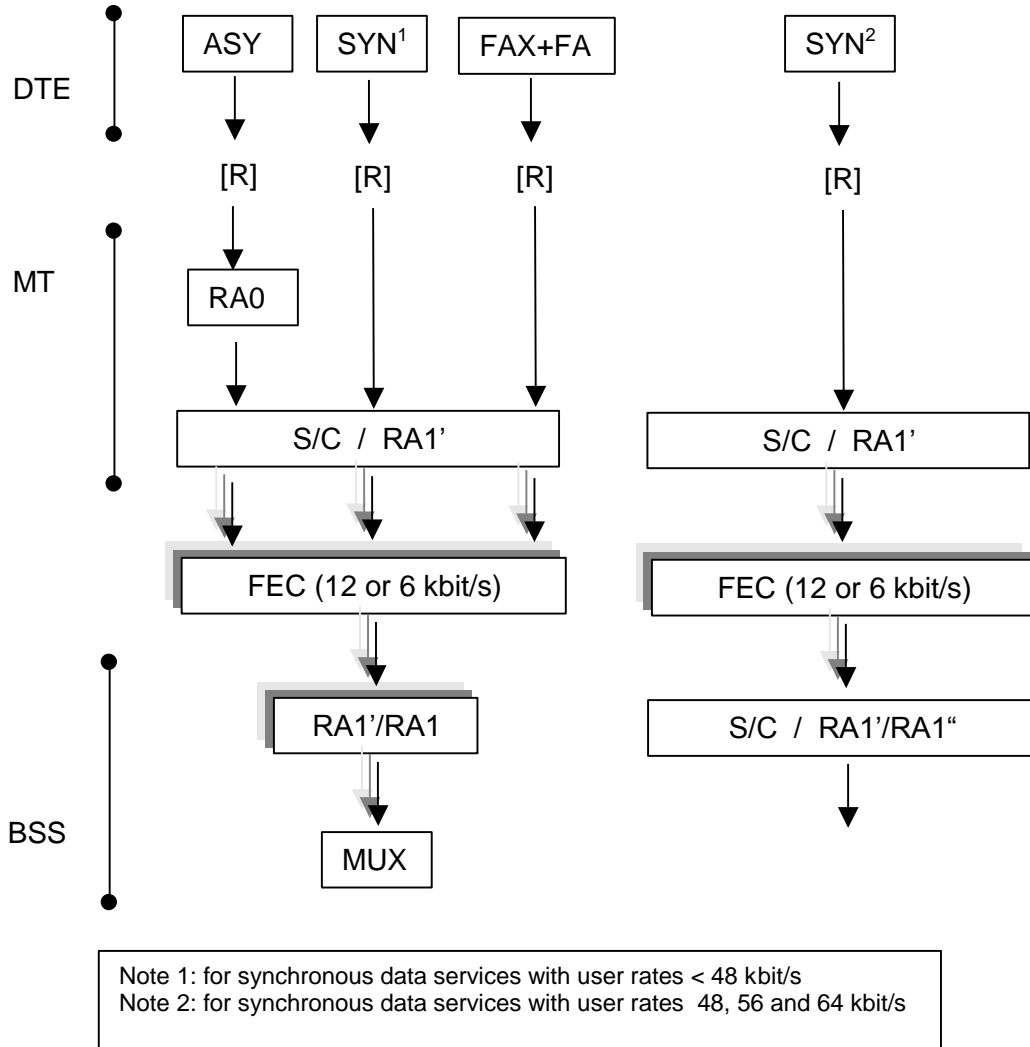

For the non-transparent services, the following stacks of rate adaptation and functions are possible:

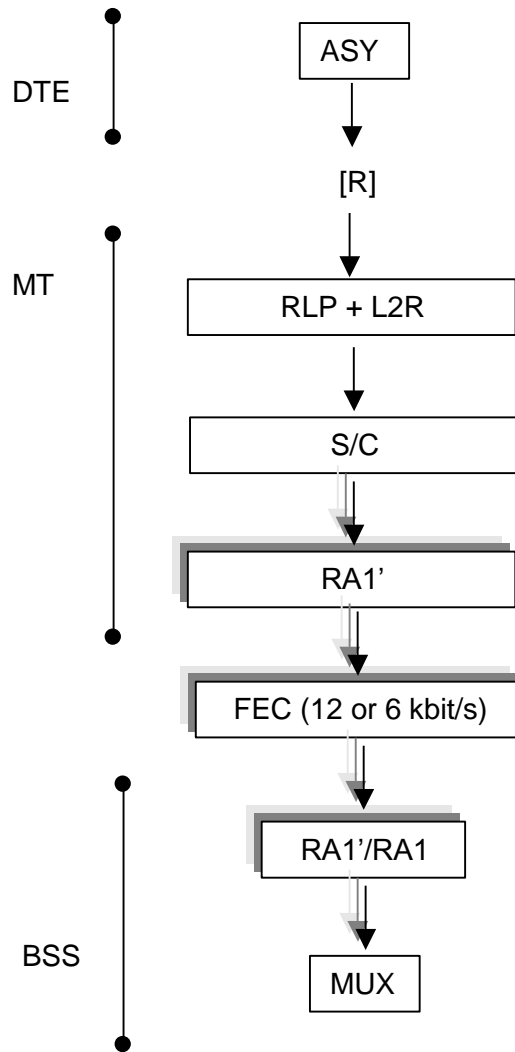

# A.4 Stacks of rate adaptation for 14,4 kbit/s multi slot operation

For transparent data services, the following stacks of rate adaptation are possible:

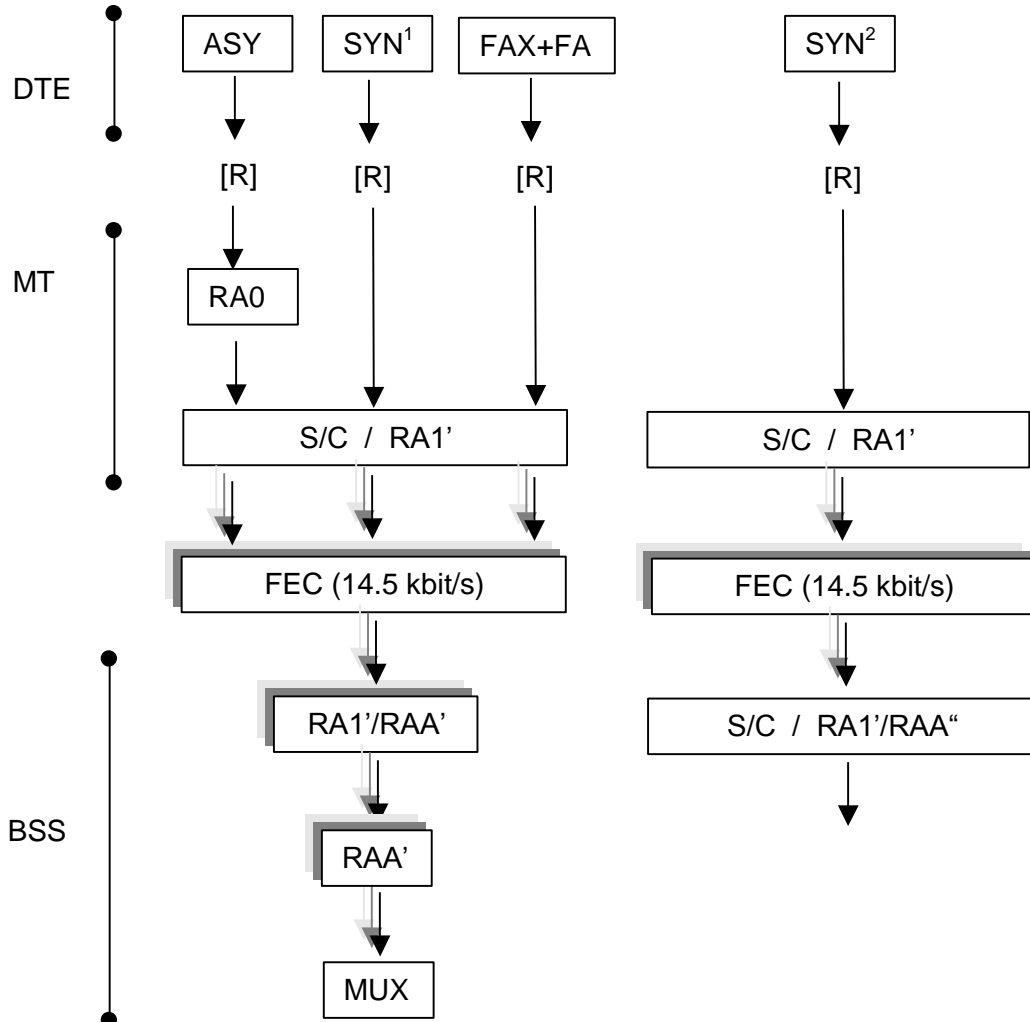

Note 1: for synchronous data services with user rates < 64 kbit/s  
 Note 2: for synchronous data services with user rate 64 kbit/s

For the non-transparent services, the following stacks of rate adaptation and functions are possible:

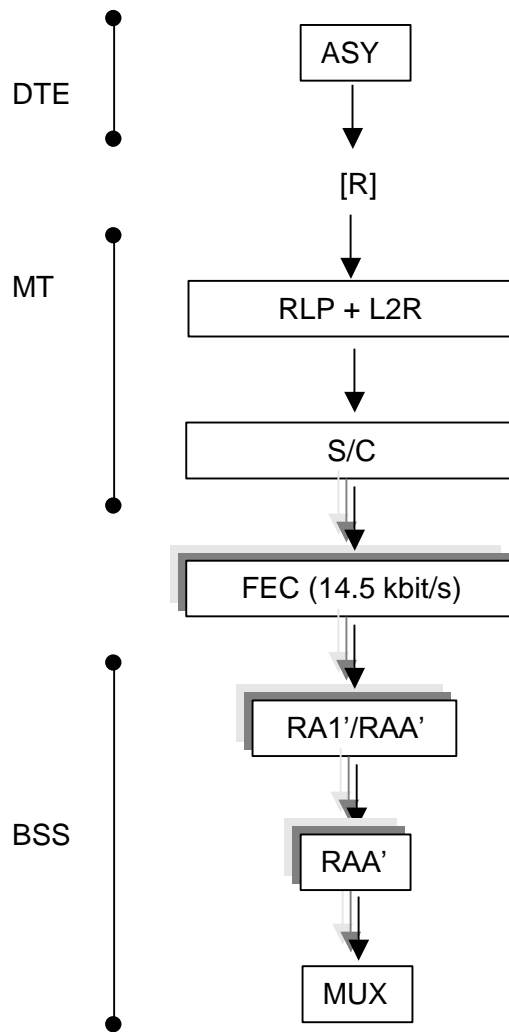

# A.5 Stacks of rate adaptation for EDGE channels TCH28.8 and TCH/F43.2 (NT only)

For transparent data services, the following stacks of rate adaptation are possible:

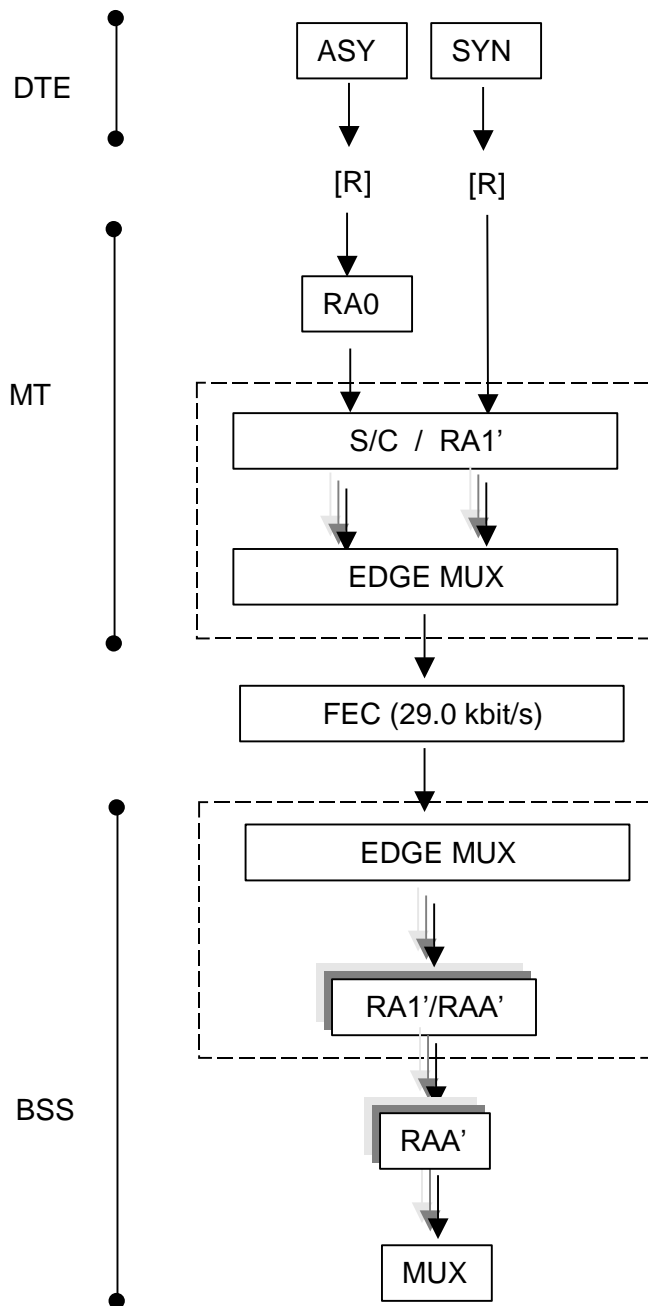



For the non-transparent services, the following stacks of rate adaptation and functions are possible:

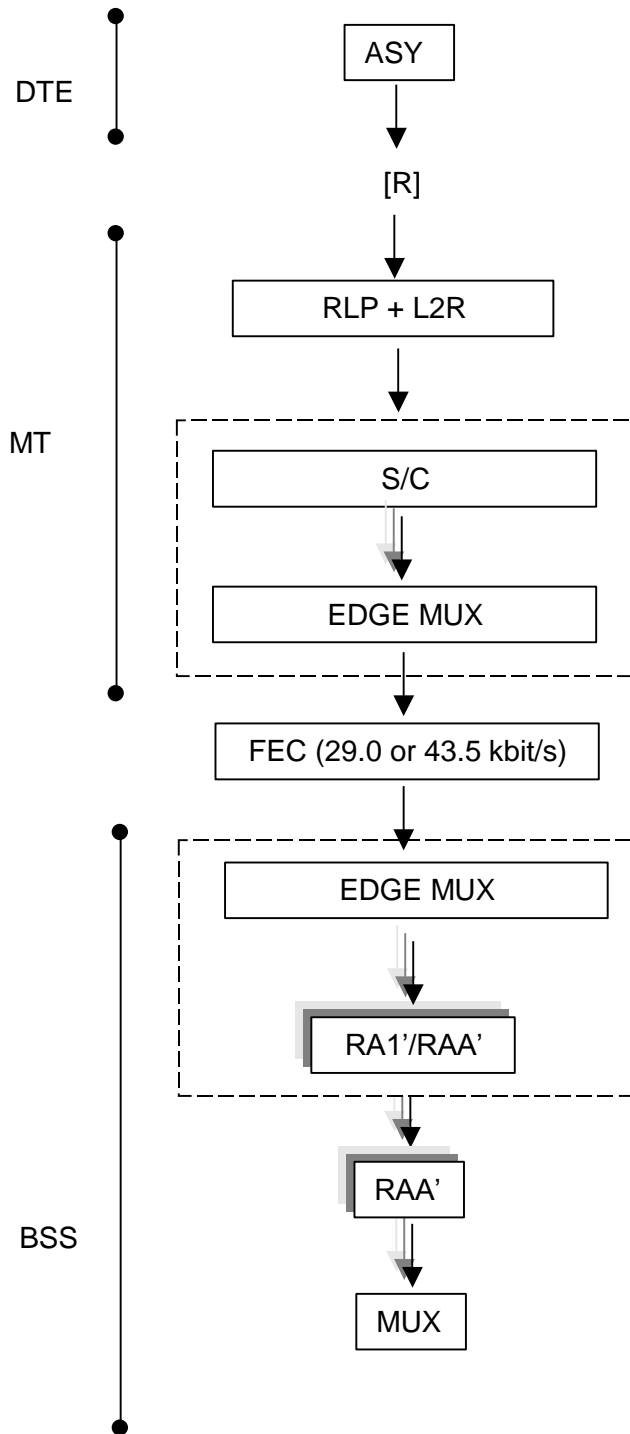

---

## Annex B (Informative): An example of mapping Network Independent Clocking information for TCH/F14.4 when the S-interface is deployed

In the following, when data bits are moved forwards or backwards between data frames and blocks, padded bit positions are skipped, and the data is moved between bit positions occupied by data bits, i.e. data bit positions.

### Negative compensation:

- a) From overall data stream to substreams

When the data is mapped from the V.110-frames to the radio interface blocks, the 'extra null bit' (subclause 5.1.1) is dropped and remapped to the first data bit position of radio interface block number 28, which is the block carrying the fifth N-bit in the 31-block multiframe structure.

- b) From substreams to overall data stream

When a radio interface block carrying the fifth bit of an NIC-code indicating negative compensation is received, the receiver discards the data in the first data bit position of the block.

### Positive compensation:

- a) From overall data stream to substreams

When the data is mapped from the V.110-frames to the radio interface blocks, the extra bit — either 0 or 1 — is added to the data flow in the correct position (subclause 5.1.1). This means that the 36-bit frame (inside a radio-interface block) in which this has taken place has a bit overflow; this overflow is carried over to the next frames and to the next radio interface blocks; i.e. bit position 1 of the following frame/block would carry the user data bit that originally was the last non-padded bit in the previous frame/block. The overflow is halted in the block carrying the second bit of the NIC-code; the value of the N-bit carried by this block (by bit M2) is set to either 1 or 0 depending on the value of the bit that would be mapped to the first data bit position of the block if the overflow carry over would continue. If this bit is a 1, the N-bit is set to 0 (positive compensation of a 1); if the bit is a 0, the N-bit is set to 1 (positive compensation of a 0). The bit that has been thus coded is not mapped to the first data bit position but carried by the NIC-code. The following bits are moved up by one data bit position.

- b) From substreams to overall data stream

When a radio interface block indicating positive compensation is received from the radio, the NIC is decoded and the data is mapped into the V.110-frames in the overall data stream. Decoding the NIC means that an 'extra bit' emerges. This bit takes its real place in the overall data stream (before the first data bit position of the block carrying the second bit of the NIC-code.) Thus a bit overflow results. This overflow is carried over the V.110-frames until an air-interface block associated with the M2-bit carrying the fifth bit of the NIC-code (subclause 5.1.1) has been fully received. After such block is received the next two suitable V.110-frames carry an NIC-code; the overflow of one bit which has been carried over a sequence of V.110-frames halts here as the second V.110-frame carries one extra bit; the value of the D-bit following the E4-E7 sequence in the V.110-frame is carried by the NIC-code and the following data bits are moved up by one step in the V.110-frame.

## Annex C (Informative): Change history

Change history							
Date	TSG #	TSG Doc.	CR	Rev	Subject/Comment	Old	New
-	s21	-	A004		HSCSD	5.0.0	5.1.0
-	s21	-	A005		Support of 14.4 kbit/s (Radio interface related)	5.0.0	5.1.0
-	s22	-	A006		Corrections and improvements for 14.4 kbit/s	5.1.1	5.2.0
-	s22	-	A007		Clarification to HSCSD	5.1.1	5.2.0
-	s23	-	A008		Editorial changes, rate adaptation procedure	5.2.0	5.3.0
-	s24	-	A009		Removal of 2*14.4=19.2 Transparent configuration	5.3.0	5.4.0
-	s24	-	A010		Update of the protocol stack models in Annex A	5.3.0	5.4.0
-	s25	-	A011		Clarification to the association between channel codings and intermediate rates	5.4.0	5.5.0
-	s27	-	A012		Synchronisation	5.5.0	7.0.0
-	s27	-	A013		Break handling	7.0.0	7.0.1
-	s29	-	A014		Introduction of EDGE channel codings into the specifications	7.0.1	8.0.0
-	s32	-	A018		Harmonisation of split / combine function	8.0.0	8.1.0
09-2000	TSG#09	NP-000551	A019	1	32 kbit/s UDI/RDI multimedia in GSM	8.1.0	8.2.0
12-2000	TSG#10	NP-000604	A020		Removal of the 1200/75 bit/s data rate and general clean-up	8.2.0	8.3.0
12-2000	TSG#10	NP-000605	A021		Handover for 56 kbit/s	8.2.0	8.3.0
12-2000	TSG#10	NP-000606	A022		Removal of BS30 NT - moved from [04.21 to 44.021]	8.3.0	4.0.0
12-2001	TSG#14	NP-010604	001	1	Terminology clarifications requested by TSG GERAN	4.0.0	5.0.0
09-2002	TSG#17	NP-020405	002	3	Correction of Rate Adaptation RA1/RA1' for higher User Rates and removal of S Reference Point in MS	5.0.0	5.1.0
09-2002	TSG#17	NP-020405	003		Correction of protocol stacks in annex A	5.0.0	5.1.0
10-2002					Replace corrupted diagram in figure 2a	5.1.0	5.1.1
12-2002	TSG#18	NP-020617	004	1	CS Data Services (including HSCSD and EDGE) for GERAN lu mode	5.1.1	5.2.0
12-2004	CN#26				Upgraded to v6.0.0	5.2.0	6.0.0
06-2007	CT#36				Upgraded to v7.0.0	6.0.0	7.0.0
12-2008	CT#42				Upgraded to v8.0.0	7.0.0	8.0.0
12-2009	CT#46				Automatic upgrade from previous Release	8.0.0	9.0.0
03-2011	CT#51				Automatic upgrade from previous Release version 9.0.0	9.0.0	10.0.0
03-2011	CT#51				Correction of heading and numbering made by MCC	10.0.0	10.0.1
09-2012	CT#57				Automatic upgrade from previous Release version 10.0.1	10.0.1	11.0.0