

3GPP TS 44.001 V11.0.0 (2012-09)

Technical Specification

3rd Generation Partnership Project; Technical Specification Group Core Network and Terminals; Mobile Station - Base Station System (MS - BSS) interface; General aspects and principles (Release 11)



The present document has been developed within the 3rd Generation Partnership Project (3GPP™) and may be further elaborated for the purposes of 3GPP.

The present document has not been subject to any approval process by the 3GPP Organizational Partners and shall not be implemented. This Specification is provided for future development work within 3GPP only. The Organizational Partners accept no liability for any use of this Specification. Specifications and reports for implementation of the 3GPP™ system should be obtained via the 3GPP Organizational Partners' Publications Offices.

Keywords

GSM, network, terminal, base station

3GPP

Postal address

3GPP support office address

650 Route des Lucioles - Sophia Antipolis
Valbonne - FRANCE
Tel.: +33 4 92 94 42 00 Fax: +33 4 93 65 47 16

Internet

<http://www.3gpp.org>

Copyright Notification

No part may be reproduced except as authorized by written permission.
The copyright and the foregoing restriction extend to reproduction in all media.

© 2012, 3GPP Organizational Partners (ARIB, ATIS, CCSA, ETSI, TTA, TTC).
All rights reserved.

UMTS™ is a Trade Mark of ETSI registered for the benefit of its members
3GPP™ is a Trade Mark of ETSI registered for the benefit of its Members and of the 3GPP Organizational Partners
LTE™ is a Trade Mark of ETSI currently being registered for the benefit of its Members and of the 3GPP Organizational Partners
GSM® and the GSM logo are registered and owned by the GSM Association

Contents

| | |
|---|-----------|
| Foreword | 4 |
| 0a Scope | 5 |
| 0b References..... | 5 |
| 0c Definitons and abbreviations | 6 |
| 1 General..... | 6 |
| 2 Interface applications | 6 |
| 3 Interface technical specification objectives | 7 |
| 4 Interface characteristics | 7 |
| 5 Interface capabilities | 8 |
| 6 Technical Specifications on GSM MS-BSS interfaces | 8 |
| 7 Protocol mode lling principles..... | 8 |
| Annex A (informative): Change History..... | 11 |

Foreword

This Technical Specification has been produced by the 3rd Generation Partnership Project (3GPP).

The contents of the present document are subject to continuing work within the TSG and may change following formal TSG approval. Should the TSG modify the contents of the present document, it will be re-released by the TSG with an identifying change of release date and an increase in version number as follows:

Version x.y.z

where:

- x the first digit:
 - 1 presented to TSG for information;
 - 2 presented to TSG for approval;
 - 3 or greater indicates TSG approved document under change control.
- y the second digit is incremented for all changes of substance, i.e. technical enhancements, corrections, updates, etc.
- z the third digit is incremented when editorial only changes have been incorporated in the document.

0a Scope

The present document describes the general aspects and principles relating to the Technical Specifications for the GSM MS-BSS interface.

0b References

The following documents contain provisions which, through reference in this text, constitute provisions of the present document.

- References are either specific (identified by date of publication, edition number, version number, etc.) or non-specific.
- For a specific reference, subsequent revisions do not apply.
- For a non-specific reference, the latest version applies. In the case of a reference to a 3GPP document (including a GSM document), a non-specific reference implicitly refers to the latest version of that document *in the same Release as the present document*.

- [1] Void.
- [1a] 3GPP TR 21.905: "Vocabulary for 3GPP Specifications".
- [2] 3GPP TS 22.030: "Man-Machine Interface (MMI) of the User Equipment (UE)".
- [3] 3GPP TS 24.002: "GSM - UMTS Public Land Mobile Network (PLMN) access reference configuration".
- [4] 3GPP TS 44.003: "Mobile Station - Base Station System (MS - BSS) interface; Channel structures and access capabilities".
- [5] 3GPP TS 44.004: "Layer 1; General requirements".
- [6] 3GPP TS 44.005: "Data Link (DL) layer; General aspects".
- [7] 3GPP TS 44.006: "Mobile Station - Base Station System (MS - BSS) interface; Data Link (DL) layer specification".
- [8] 3GPP TS 24.007: "Mobile radio interface signalling layer 3; General aspects".
- [9] 3GPP TS 24.008: "Mobile radio interface; Layer 3 specification; Core network protocols; Stage 3".
- [10] 3GPP TS 24.010: "Mobile radio interface layer 3; Supplementary services specification; General aspects".
- [11] 3GPP TS 24.011: "Point-to-Point (PP) Short Message Service (SMS) support on mobile radio interface".
- [12] 3GPP TS 44.012: "Short Message Service Cell Broadcast (SMSCB) support on the mobile radio interface".
- [13] ITU-T Recommendation X.200: "Information technology - Open Systems Interconnection - Basic Reference Model: The basic model".
- [14] ITU-T Recommendation X.210: "Information technology - Open systems interconnection - Basic Reference Model: Conventions for the definition of OSI services".

0c Definitions and abbreviations

Abbreviations used in the present document are listed in 3GPP TR 21.905.

1 General

1.1

A GSM PLMN supports a wide range of services which a user accesses by a standard set of interfaces at a mobile station (MS). The mobile station is connected to the PLMN fixed infrastructure via a radio path to a base station, as shown in figure 1.

1.2

The MS-BSS interface on this radio path is specified in the 24- and 44-series of Technical Specifications in such a way as to permit user and network technologies and configurations to evolve separately.

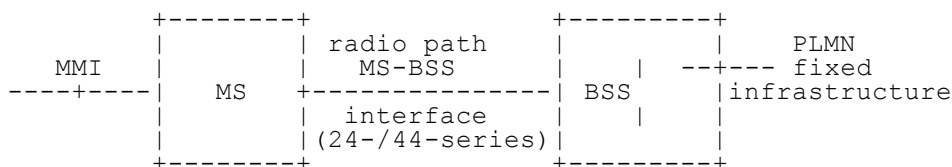

Figure 1: Basic interfaces for user access for a GSM PLMN

1.3

The principles and procedures for the man-machine interface (MMI) to the MS are described in Technical Specification 3GPP TS 22.030. The user may also use standard terminal interfaces within the MS. The reference configuration for the access is described in Technical Specification 3GPP TS 24.002.

2 Interface applications

Figure 2 shows some examples of the application of GSM MS-BSS interfaces. The following cases are shown:

- i) access of simple handportable or vehicle mounted MSs;
- ii) access of an MS with multiple terminal equipment installation;
- iii) access of a mobile PBX or LAN;

In addition, the figure identifies internetwork interfaces for connections to:

- iv) land-line ISDN networks;
- v) dedicated service networks.

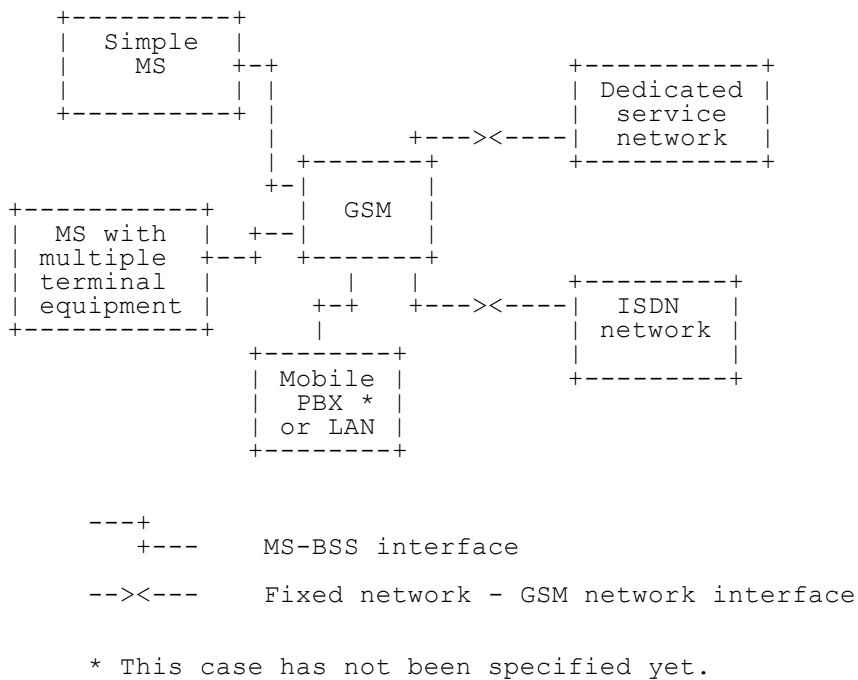

Figure 2: Examples of GSM interfaces

3 Interface technical specification objectives

MS-BSS interface Technical Specifications should allow:

- i) different types of mobile stations and terminal equipment to use the same standard interface;
- ii) portability of MSs within the system area of the GSM system;
- iii) separate evolution of both mobile stations and network equipment technologies and configurations;
- iv) calls to a terminal using the same code (call number) no matter in what country it is actually located;
- v) connections of an MS to the ISDN network so that only the radio channel capacity and the ISDN protocol are limiting factors.

4 Interface characteristics

The MS-BSS interface is specified by a comprehensive set of characteristics, including:

- i) channel structures and access capabilities;
- ii) user-network (MS-BSS) protocols;
- iii) maintenance and operation characteristics;
- iv) performance characteristics;
- v) service characteristics.

5 Interface capabilities

In addition to the multiservice capability, the GSM MS-BSS interface may allow for capabilities such as the following:

- i) multidrop and other multiple terminal arrangements;
- ii) choice of information bit rate, circuit or packet switching mode, layer 2 coding method, etc., on a call-by-call or other basis (e.g. semipermanent, or subscription time option), over the same interface according to the user's need;
- iii) capability for compatibility checking in order to check whether calling and called terminals can communicate with each other.

6 Technical Specifications on GSM MS-BSS interfaces

6.1

The reference configurations for the GSM MS-BSS interface define the terminology for various reference points. Technical Specification 3GPP TS 24.002 contains the GSM PLMN access reference configuration.

6.2

Technical Specification 3GPP TS 44.003 defines the channel structures and access capabilities for the MS-BSS interface. A distinction is necessary between the logical channel structure supported by the interface and the access capability supported by the radio path of the system.

6.3

The MS-BSS interface as defined in Technical Specifications 3GPP TS 44.004, 3GPP TS 44.005, 3GPP TS 44.006, 3GPP TS 24.007, 3GPP TS 24.008, 3GPP TS 24.010, 3GPP TS 24.011 and 3GPP TS 44.012 is applicable to a wide range of situations.

7 Protocol modelling principles

7.1

The signalling protocols on the MS-BSS Interface are specified using the concepts of the reference model of Open System Interconnection (OSI) given in ITU-T Recommendations X.200 and X.210.

7.2

The basic structuring technique in the OSI reference model is layering. According to this technique, communication among application processes is viewed as being logically partitioned into an ordered set of layers represented in a vertical sequence as shown in figure 3.

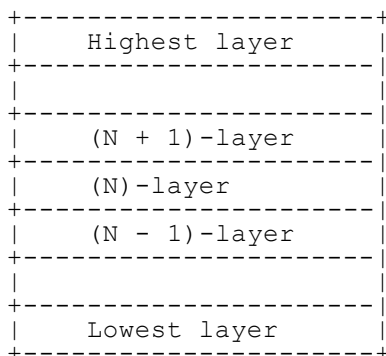

Figure 3: Layering

Entities exist in each layer. Entities in the same layer, but in different systems which must exchange information to achieve a common objective are called "peer entities". Entities in adjacent layers interact through their common boundary. The services provided by the (N + 1)-layer are the combination of the services and functions provided by the (N)-layer and all layers below the (N)-layer.

Management functions may also be required. They may include functions which are common for several layers and are not supported by the services provided by a specific layer. Examples of such functions are error reporting, status reporting and management of the operation of certain layers. Such management functions do not require that peer-to-peer messages are sent across the MS-BSS interface.

7.3

For signalling on the MS-BSS interface three layers are required as shown in figure 4.

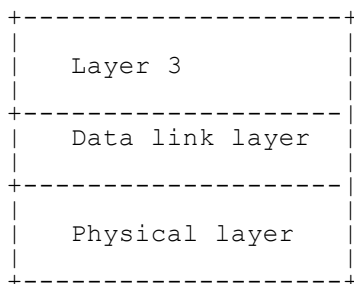

Figure 4: Layering on the MS-BSS interface

The layers are:

- PHYSICAL LAYER which corresponds to the lowest layer. The functions and protocols of the physical layer are defined in Technical Specification 3GPP TS 44.004.
- DATA LINK LAYER. The functions and protocols of the data link layer are defined in Technical Specifications 3GPP TS 44.005 and 3GPP TS 44.006.
- LAYER 3. The functions and protocols of layer 3 are defined in Technical Specifications 3GPP TS 24.007, 3GPP TS 24.008, 3GPP TS 24.010, 3GPP TS 24.011 and 3GPP TS 44.012.

7.4

Layer-to-layer interactions are specified in terms of service primitives. The primitives represent, in an abstract way, the logical exchange of information and control between adjacent layers. They do not specify or constrain implementation.

Primitives are also used to describe information exchange between layers and the mobile management entity.

The primitives that are exchanged between the (N + 1)-layer and the (N)-layer are of the following four types (see figure 5).

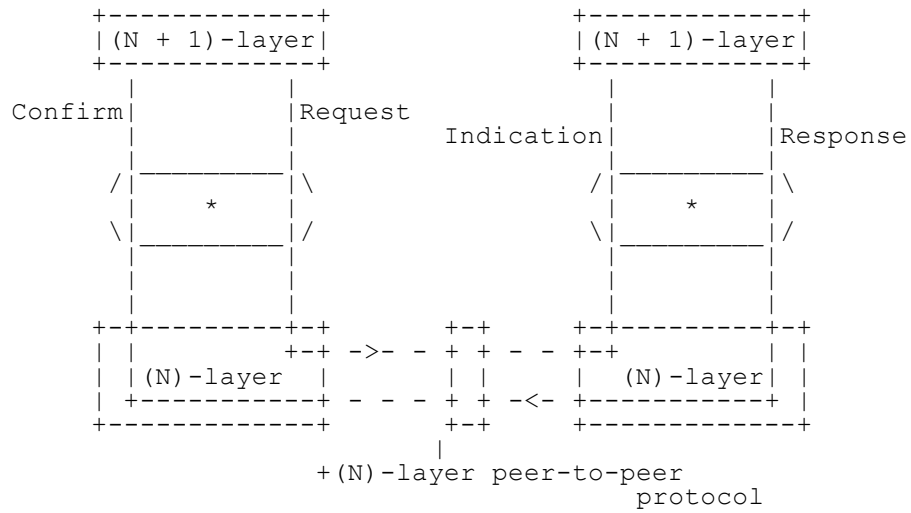

Figure 5: Primitive action sequence for peer-to-peer communication

The REQUEST primitive type is used when a higher layer is requesting a service from the next lower layer.

The INDICATION primitive type is used by a layer providing a service to notify the next higher layer of activities related to the primitive type REQUEST.

The RESPONSE primitive type is used by a layer to acknowledge receipt, from a lower layer, of the primitive type INDICATION.

The CONFIRM primitive type is used by the layer providing the requested service to confirm that the activity has been completed.

Annex A (informative): Change History

| Meeting No. | TDoc. No. | CR. No. | Section affected | New version | Subject/Comments |
|-------------|-----------|---------|------------------|-------------|---|
| SMG#07 | | | | 4.0.4 | Phase 2 version |
| SMG#20 | | | | 5.0.0 | Release 1996 version |
| SMG#27 | | | | 6.0.0 | Release 1997 version |
| SMG#29 | | | | 7.0.0 | Release 1998 version |
| SMG#31 | | | | 8.0.0 | Release 1999 version |
| CN#11 | | | | 4.0.0 | Release 4 version |
| NP-16 | NP-020224 | 001 | | 4.1.0 | Various clean-up of wrong references |
| NP-16 | | | | 5.0.0 | Plenary decision to make this TS also for Rel-5. |
| NP-26 | | | | 6.0.0 | Plenary decision to make this TS also for Rel-6. |
| | | | | 7.0.0 | Plenary decision to make this TS also for Rel-7. |
| CP-42 | | | | 8.0.0 | Plenary decision to make this TS also for Rel-8. |
| CP-46 | | | | 9.0.0 | Plenary decision to make this TS also for Rel-9. |
| CP-51 | | | | 10.0.0 | Plenary decision to make this TS also for Rel-10. |
| CP-57 | | | | 11.0.0 | Plenary decision to make this TS also for Rel-11. |