

3GPP TS 43.050 V11.0.0 (2012-09)

Technical Specification

3rd Generation Partnership Project; Technical Specification Group Services and System Aspects; Transmission planning aspects of the speech service in the GSM Public Land Mobile Network (PLMN) system (Release 11)



The present document has been developed within the 3rd Generation Partnership Project (3GPP™) and may be further elaborated for the purposes of 3GPP.

The present document has not been subject to any approval process by the 3GPP Organizational Partners and shall not be implemented. This Specification is provided for future development work within 3GPP only. The Organizational Partners accept no liability for any use of this Specification. Specifications and reports for implementation of the 3GPP™ system should be obtained via the 3GPP Organizational Partners' Publications Offices.

Keywords

GSM, speech

3GPP

Postal address

3GPP support office address

650 Route des Lucioles - Sophia Antipolis
Valbonne - FRANCE
Tel.: +33 4 92 94 42 00 Fax: +33 4 93 65 47 16

Internet

<http://www.3gpp.org>

Copyright Notification

No part may be reproduced except as authorized by written permission.
The copyright and the foregoing restriction extend to reproduction in all media.

© 2012, 3GPP Organizational Partners (ARIB, ATIS, CCSA, ETSI, TTA, TTC).
All rights reserved.

UMTS™ is a Trade Mark of ETSI registered for the benefit of its members
3GPP™ is a Trade Mark of ETSI registered for the benefit of its Members and of the 3GPP Organizational Partners
LTE™ is a Trade Mark of ETSI currently being registered for the benefit of its Members and of the 3GPP Organizational Partners
GSM® and the GSM logo are registered and owned by the GSM Association

Contents

Foreword	6
1 Scope	7
1.1 References.....	7
1.2 Abbreviations.....	9
1.3 Introduction	10
2 Network configurations	10
2.1 General	10
2.2 Model of the PLMN	10
2.3 Interfaces	10
2.4 Configurations of connections	11
2.4.1 General configurations of connections	11
2.4.2 Reference configurations to illustrate delay and echo control issues.....	11
2.5 4-wire circuits in the PLMN	12
3 Transmission performance	12
3.1 Overall Loss/Loudness ratings	13
3.1.1 Connections with handset MSs.....	13
3.1.2 Connections with handsfree MSs	13
3.1.3 Connections with headset MSs.....	13
3.2 Stability Loss.....	14
3.3 Delay	14
3.3.1 General.....	14
3.3.2 Sources of delay	14
3.3.2.1 Elements of the PLMN that cause delay	14
3.3.2.2 Elements of the PSTN that cause delay	14
3.3.3 Effects of delay	14
3.3.4 Allocation of delay to the PLMN	15
3.3.4.1 Allocation of delay to the PLMN when using a full rate system.....	15
3.3.4.2 Allocation of delay to the PLMN when using a half rate system.....	15
3.3.5 Delay of various network configurations.....	15
3.3.5.1 National and international connections with no echo control in the PSTN (reference configurations A).....	15
3.3.5.2 National and international connections with echo control in the PSTN (reference configurations B)	15
3.3.5.3 Connections where re-routeing leads to a significant increase in transmission path length (reference configurations C)	16
3.3.6 Delay related requirements on the MS.....	16
3.3.6.1 Full rate MS	16
3.3.6.2 Half rate MS	16
3.3.6.3 Handsfree MS	16
3.4 Echo	16
3.4.1 General	16
3.4.2 Electrical echo control in the PLMN (Reference configurations A).....	17
3.4.3 Acoustic echo control in the PLMN	17
3.4.4 Interaction between tandem echo control devices (reference configurations B & C)	17
3.5 Clipping	17
3.5.1 General.....	17
3.5.2 Properties of voice switches in the PLMN	18
3.5.3 Problems of tandem voice switching	18
3.6 Idle channel noise (handset and headset MS).....	18
3.6.1 Sending	18
3.6.2 Receiving.....	18
3.7 Noise contrast.....	18
3.7.1 General	18
3.7.2 Elements of a PLMN which can cause noise contrast impairment.....	19
3.7.3 Reduction of noise contrast	19

3.7.3.1	Reduction of noise contrast by limiting the noise received by the microphone	19
3.7.3.1.1	Headset MS.....	19
3.7.3.1.2	Handset MS.....	19
3.7.3.1.3	Handsfree MS.....	20
3.7.3.2	Reduction of noise contrast by insertion of comfort noise	20
3.7.4	Consequence of the introduction of high comfort noise levels on other voice-operated devices	20
3.8	Sensitivity/frequency characteristics.....	20
3.8.1	Headset and Handset MSs	20
3.8.1.1	Sending	20
3.8.1.2	Receiving.....	20
3.8.2	Handsfree MS	21
3.8.2.1	Sending.....	21
3.8.2.2	Receiving.....	21
3.9	Distortion (handset and headset MS).....	21
3.9.1	Gain variation, sending	21
3.9.2	Gain variation, receiving.....	21
3.10	Sidetone (handset and headset MS).....	22
3.10.1	Sidetone loss	22
3.10.1.1	LSTR.....	22
3.10.1.2	STMR.....	22
3.10.2	Sidetone distortion	22
3.11	Not used	22
3.12	Requirements for information tones.....	22
3.13	Crosstalk.....	23
3.13.1	Near and far end crosstalk	23
3.13.2	Go/return crosstalk.....	23
3.14	MS Ambient Noise Rejection.....	23
Annex A (informative): Considerations on the Acoustic Interface of the Mobile Station		32
A.1	Handsfree MS.....	32
A.2	Handset MS.....	32
A.3	Headset MS.....	32
A.4	Inter-reaction with DTX	32
Annex B (normative): Test considerations		33
Annex C (normative): Transmission requirements testing		34
C.1	Not used	34
C.2	Not used	34
C.3	Not used	34
C.4	Not used	34
C.5	Variation of gain with input level	34
C.5.1	Sending.....	34
C.5.2	Receiving	34
C.6	Not used.....	34
C.7	Not used.....	34
C.8	Not used.....	34
C.9	Not used.....	34
C.10	Delay for handsfree MS.....	34
C.10.1	Uplink	34
C.10.2	Downlink.....	35
C.10.3	Result.....	35

Annex D (normative): MS delay requirement definition36
D.1 Full rate MS delay requirement definition36
D.2 Half rate MS delay requirement definition37
Annex E (informative): Adaptive gain control.....38
Annex F (informative): Change History.....39

Foreword

This Technical Specification has been produced by the 3rd Generation Partnership Project (3GPP).

The contents of the present document are subject to continuing work within the TSG and may change following formal TSG approval. Should the TSG modify the contents of the present document, it will be re-released by the TSG with an identifying change of release date and an increase in version number as follows:

Version x.y.z

where:

- x the first digit:
 - 1 presented to TSG for information;
 - 2 presented to TSG for approval;
 - 3 or greater indicates TSG approved document under change control.
- y the second digit is incremented for all changes of substance, i.e. technical enhancements, corrections, updates, etc.
- z the third digit is incremented when editorial only changes have been incorporated in the document.

1 Scope

The present document describes the transmission planning aspects pertaining to the speech service in the GSM PLMN system. Due to technical and economic factors, there cannot be full compliance with the general characteristics of international telephone connections and circuits recommended by the ITU-T.

The present document gives guidance as to the precautions, measures and minimum requirements needed for successful interworking of the PLMN with the national and international PSTN. The present document identifies a number of routing and network configurations. The objective is to reach a quality as close as possible to ITU-T standards in order to safeguard the performance seen by PSTN customers.

The requirements stated for acoustics in dual mode GSM/3GPP handsets shall be interpreted as requirement on acoustics in the GSM mode.

1.1 References

The following documents contain provisions which, through reference in this text, constitute provisions of the present document.

- References are either specific (identified by date of publication, edition number, version number, etc.) or non-specific.
- For a specific reference, subsequent revisions do not apply.
- For a non-specific reference, the latest version applies. In the case of a reference to a 3GPP document (including a GSM document), a non-specific reference implicitly refers to the latest version of that document *in the same Release as the present document*.

- [1] 3GPP TR 41.004: "Digital cellular telecommunications system (Phase 2+); Abbreviations and acronyms".
- [2] 3GPP TS 43.004: "Digital cellular telecommunications system (Phase 2+); Signalling requirements relating to routing of calls to mobile subscribers".
- [3] 3GPP TS 46.001: "Digital cellular telecommunications system (Phase 2+); Full rate speech processing functions".
- [4] 3GPP TS 46.010: "Digital cellular telecommunications system (Phase 2+); Full rate speech; Transcoding".
- [5] 3GPP TS 46.011: "Digital cellular telecommunications system (Phase 2+); Full rate speech; Substitution and muting of lost frames for full rate speech channels".
- [6] 3GPP TS 46.012: "Digital cellular telecommunications system (Phase 2+); Full rate speech; Comfort noise aspect for full rate speech traffic channels".
- [7] 3GPP TS 46.031: "Digital cellular telecommunications system (Phase 2+); Full rate speech; Discontinuous Transmission (DTX) for full rate speech traffic channels".
- [8] 3GPP TS 46.032: "Digital cellular telecommunications system (Phase 2+); Voice Activity Detection (VAD)".
- [9] 3GPP TS 46.002: "Digital cellular telecommunications system (Phase 2+); Half rate speech; Half rate speech processing functions".
- [10] 3GPP TS 46.020: "Digital cellular telecommunications system (Phase 2+); Half rate speech; Half rate speech transcoding".
- [11] 3GPP TS 46.021: "Digital cellular telecommunications system (Phase 2+); Half rate speech; Substitution and muting of lost frames for half rate speech traffic channels".

- [12] 3GPP TS 46.022: "Digital cellular telecommunications system (Phase 2+); Half rate speech; Comfort noise aspects for half rate speech traffic channels".
- [13] 3GPP TS 46.041: "Digital cellular telecommunications system (Phase 2+); Half rate speech; Discontinuous Transmission (DTX) for half rate speech traffic channels".
- [14] 3GPP TS 46.042: "Digital cellular telecommunications system (Phase 2+); Half rate speech; Voice Activity Detection (VAD) for half rate speech traffic channels".
- [15] I-ETS 300 245-2: "Integrated Services Digital Network (ISDN): Technical characteristics of telephony terminals: Part 2: PCM A-Law handset telephony".
- [16] ITU-T Recommendation G.103 (1998): "Hypothetical reference connections".
- [17] ITU-T Recommendation G.111 (1993): "Loudness ratings (LRs) in an international connection".
- [18] ITU-T Recommendation G.113 (1996): "Transmission impairments".
- [19] ITU-T Recommendation G.114 (2000): "Mean one-way propagation time".
- [20] ITU-T Recommendation G.121 (1993): "Loudness ratings (LRs) of national systems".
- [21] ITU-T Recommendation G.122 (1993): "Influence of national systems on stability, talker echo, and listener echo in international connections".
- [22] ITU-T Recommendation G.131 (1996): "Control of talker echo".
- [23] ITU-T Recommendation G.168 (2000): "Digital network echo cancellers".
- [24] ITU-T Recommendation G.223 (1988): "Assumptions for the calculation of noise on hypothetical reference circuits for telephony".
- [25] ITU-T Recommendation G.703 (1998): "Physical/electrical characteristics of hierarchical digital interfaces".
- [26] ITU-T Recommendation G.711 (1988): "Pulse code modulation (PCM) of voice frequencies".
- [27] ITU-T Recommendation G.712 (1996): "Transmission performance characteristics of pulse code modulation".
- [28] ITU-T Recommendation G.167 (1993): "Acoustic Echo Controllers".
- [29] ITU-T Recommendation M.1020 (1993): "Characteristics of special quality international leased circuits with special bandwidth conditions".
- [30] ITU-T Recommendation M.1025 (1993): "Characteristics of special quality international leased circuits with basic bandwidth conditioning".
- [31] ITU-T Recommendation M.1030 (1988): "Characteristics of ordinary quality international leased circuits forming part of private switched telephone networks".
- [32] ITU-T Recommendations M.1040 (1988): "Characteristics of ordinary quality international leased circuits".
- [33] ITU-T Recommendation O.132 (1988): "Specification for a quantizing distortion measuring apparatus using a sinusoidal test signal".
- [34] ITU-T Recommendation P.11 (1993): "Effect of transmission impairments".
- [35] ITU-T Recommendation P.340(2000): "Transmission characteristics of hands-free telephones".
- [36] ITU-T Recommendation P.38 (1993): "Transmission characteristics of operator telephone systems (OTS)".
- [37] ITU-T Recommendation P.50 (1999): "Artificial voices".
- [38] ITU-T Recommendation P.51 (1996): "Artificial mouths".

- [39] ITU-T Recommendation P.64 (1999): "Determination of sensitivity/frequency characteristics of local telephone systems".
- [40] ITU-T Recommendation P.76 (1988): "Determination of loudness ratings; fundamental principles".
- [41] ITU-T Recommendation P.79 (1999): "Calculation of loudness ratings".
- [42] ITU-T Recommendation Q.35/E180 (1998): "Technical characteristics of tones for the telephone service".
- [43] ITU-T Recommendation Q.551 (1996): "Transmission characteristics of digital exchanges".
- [44] ITU-T Blue Book (1988): "Volume V, Supplement 13: Noise spectra".
- [45] ISO 3 (1973): "Preferred numbers – series of preferred numbers".
- [46] ITU-T Recommendation P.57 (1996): "Artificial Ears".
- [47] ITU-T Recommendation P.58 (1996): "Head and Torso Simulator for Telephonometry".
- [48] I-ETS 300 245-3: "Integrated Services Digital Network (ISDN): Technical characteristics of telephony terminal: Part 3: PCM A-law loudspeaking and handsfree telephony".
- [49] 3GPP TS 26.131: "Terminal Acoustic Characteristics for Telephony; Requirements"
- [50] 3GPP TS 26.132: "Speech and video telephony terminal acoustic test specification"
- [51] 3GPP TS 51.010: "Digital cellular telecommunications system (Phase 2+); Mobile Station (MS) conformance specification"

1.2 Abbreviations

In addition to those below, the abbreviations used in the present document are listed in GSM 01.04.

ADC	Analogue to Digital Converter
ADPCM	Adaptive Differential Pulse Code Modulation
AEC	Acoustic Echo Control
BSC	Base Station Controller (excluding transmission systems)
BTS	Base Transceiver Station (excluding transmission systems)
DAC	Digital to Analogue Converter
DMR	Digital Mobile Radio
DSI	Digital Speech Interpolation
EEC	Electric Echo Control
EL	Echo Loss
ERP	Ear Reference Point
FDM	Frequency Division Multiplex
ISC	International Switching
LE	Local Exchange
LSTR	Listener Sidetone Rating
MRP	Mouth Reference Point
OLR	Overall Loudness Rating
PCM	Pulse Code Modulation
POI	Point of Interconnection (with PSTN)
RLR	Receiver Loudness Rating
SLR	Send Loudness Rating
STMR	Sidetone Masking Rating
UPCMI	13-bit Uniform PCM Interface

1.3 Introduction

Since the transmission quality and the conversational quality of the PLMN will in general be lower than the quality of the PSTN connection due to coding distortion, delay, etc., only some transmission aspects can be brought in line with ITU-T Recommendations. It is therefore necessary to improve the overall quality as much as possible by implementing proper routing and network configurations.

It should be recognized that the transmission plan for the GSM PLMN cannot lead to major changes in the PSTN. However, it is important to use the improvements in the evolving PSTN (e.g. digitalization, introduction of echo cancellers) in an effective way.

The transmission requirements are in the first place based on international connections. When the quality is sufficient for international connections, it can be assumed that the national connections will have the same or better quality.

In order to obtain a sufficient quality in the connection, it is preferable to have digital connectivity between the Base Station System (BSS) and the international exchange. The PLMN requirements are based on this assumption. When this situation cannot be provided, a lower quality must temporarily be accepted.

The present document consists of two parts: one will deal with network configurations, the other with transmission performance.

The part about network configurations gives information about the reference connections, on which the transmission plan is based. Furthermore, some guidelines are presented for improvement of the transmission quality in the evolving (digital) PSTN.

The part about transmission performance gives mainly characteristics of the transmission between MS acoustic interface (MRP/ERP) and the interface between the PLMN and the PSTN (POI). For transmission aspects where it is impossible to give overall characteristics, it is in some cases necessary to make recommendations for individual parts of the equipment.

Annex A considers the effects of the type of acoustic interfaces of the MS.

2 Network configurations

2.1 General

The basic configuration for the interworking with the PSTN is shown in figure 1.

2.2 Model of the PLMN

A more detailed model of the PLMN used for the consideration of transmission planning issues for speech is shown in figure 2. This model represents the main functions required and does not necessarily imply any particular physical realization. Routing of calls is given in GSM 03.04.

Any acoustic echo control is not specifically shown as it will be provided by analogue processing or digital processing or a combination of both techniques.

2.3 Interfaces

The main interfaces identified within the GSM specifications are shown in figure 1. For the purposes of the present document, the Air Interface and the Point of Interconnect (POI) are identified along with two other interfaces, Interface Z and a 13-bit Uniform PCM Interface (UPCMI). These interfaces are needed to define the PLMN transmission characteristics and the overall system requirements.

The Air Interface is specified by GSM 05 series specifications and is required to achieve MS transportability. Analogue measurements can be made at this point by using the appropriate radio terminal equipment and speech transcoder. The losses and gains introduced by the test speech transcoder will need to be specified.

The POI with the PSTN will generally be at the 2 048 kbits/s level at an interface, in accordance with ITU-T Recommendation G.703. At the point, which is considered to have a relative level of 0 dB, the analogue signals will be represented by 8-bit A-law, according to ITU-T Recommendation G.711. Analogue measurements may be made at this point using a standard send and receive side, as defined in ITU-T Recommendations.

Interface Z might be used in the case of direct MSC to MSC connections. Interface Z is of the same nature as the POI.

The UPCMI is introduced for design purposes in order to separate the speech transcoder impairments from the basic audio impairments of the MS.

2.4 Configurations of connections

2.4.1 General configurations of connections

Figure 3 shows a variety of configurations of connections. There are a number of PSTN features which should be avoided from such connections. These include:

- 1) echo control devices in the international network. If present, and not disabled, these devices will be in tandem with PLMN echo cancellers and may introduce degradation;
- 2) satellite routings. The delay inherent in the connections when added to the PLMN delay, may result in conversational difficulties. Double satellite links are likely to cause severe difficulties and special precautions should be taken to avoid this situation under call forwarding arrangements;
- 3) Digital Speech Interpolation systems (DSI). There is likely to be an adverse interaction between DSI and DTX;
- 4) ADPCM. The distortion introduced by ADPCM on routes where PSTN echo control is not provided is likely to reduce the echo cancellation provided by the PLMN electric echo canceller;
- 5) significant differences in clock rates on non-synchronized digital network components. The resulting phase roll and slips are likely to degrade the performance of the PLMN echo canceller;
- 6) those analogue FDM routings which exhibit phase roll. Any phase roll due to the absence of synchronization between the carrier frequencies on the two directions of transmission is likely to degrade the performance of the PLMN echo canceller;
- 7) tandem connections of sources of quantization distortion. The PLMN speech transcoder is estimated to be equivalent to 7 QDUs between uniform PCM interfaces (see ITU-T Recommendation G.113).

It is recognized that on some connections it may not be feasible to avoid these features, but in many cases, especially if taken into account at the planning stage, this should be possible.

2.4.2 Reference configurations to illustrate delay and echo control issues

Three basic reference configuration types shown in figures 4 to 6 are defined to illustrate delay and echo control issues. Intermediate echo control devices as shown in the figures are disabled by appropriate signalling between the MSC and ISC or MSC and MSC.

Reference configurations A (see figure 4) represent national or international connections where there is no echo control device in the PSTN. These reference configurations include re-routeing configurations where the overall delay of the transmission path has not been extended.

Reference configurations B (see figure 5) represent national or international connections where echo control is provided in the PSTN. These reference configurations include re-routeing configurations where the overall delay of the transmission path has not been extended.

Reference configurations C (see figure 6) represent national or international connections where re-routeing has led to an increase in the overall delay of the transmission path beyond recommended limits.

2.5 4-wire circuits in the PLMN

As shown in figure 2, the PLMN will usually contain transmission systems. Where present, they should provide 4-wire circuits.

In the case of digital circuits which do not include any speech processing devices, the overall system requirements of the PLMN will not be affected by the presence of the link.

In the case of analogue links, the transmission characteristics (e.g. attenuation, attenuation distortion, noise) will affect the overall system requirements of the PLMN. ITU-T Recommendations M.1020, M.1025, M.1030 and M.1040 describe several transmission characteristics for leased circuits. In cases where the analogue link introduces loss, provision will have to be made at the interface to restore the loss.

3 Transmission performance

The overall transmission performance of connections in alternate conversation mode can be considered as a summation of the effects of:

- 1) the audio part between the MRP/ERP and the UPCMI interface;
- 2) the speech transcoder part including the effects of radio transmission, and speech processing between the UPCMI and the POI;
- 3) the overall characteristics of the connection between POI and the other user.

There is not only a linear addition of these effects but there is also an influence from different parts of the connection on the performance of the speech transcoder and other speech processing devices.

Where possible, the transmission performance is specified between the MRP/ERP and the POI. Where this is not possible, the transmission aspects of the audio part mentioned above have been specified. The transmission aspects of the speech transcoder are specified in GSM 06 series specifications. In the following paragraphs, requirements are specified for the UPCMI, the Air Interface or the POI as appropriate.

The transmission requirements of the MS have been derived from the requirements of digital telephones stated in I-ETS 300 245-2 and 3.

MSs will have to work in a variety of environments ranging from quiet office locations to very noisy environments as found in moving cars. In noisy conditions, different values for the sending and receiving sensitivities relative to the nominal values can increase the performance of the terminal. Some guidance is given in annex E.

The overall transmission performance in full duplex conversation mode will also greatly depend on the performance of the echo control devices which may be included in the connection.

The handsfree requirements in the present document are designed to provide a basic level of performance and to avoid adverse interactions with other networks. Testing is carried out in one configuration in a vehicle, whilst this gives some confidence that the system can work in a typical environment, the testing is by no means complete. It is assumed that the manufacturer submits the handsfree system with the transducers fitted in reasonable locations within the vehicle (the transducers should not impede the normal operation of the vehicle or its fittings). Unusual installations should be agreed for suitability with the relevant Type Approval Authority before testing.

In a real vehicle installation, care should be taken to allow for the acoustic properties of that vehicle and the likely acoustic environment. It is important that the best possible coupling between the microphone and the MS user is achieved. Hence the microphone should be directional and mounted as close to the user's mouth as practical. The loudspeakers should be mounted in such a way that the maximum receive signal is directed at the user, rather than dissipated by the various obstacles in that vehicle, such as the seats.

Proper consideration for the noise environment and the direct coupling between the microphone and loudspeakers is necessary. Excessive noise coupled into the microphone can mask the MS user's send speech and potentially affect the operation of DTX. The vehicle noise environment can potentially mask the received speech, unless sufficient volume is provided. However, direct coupling between the transducers can cause annoying echo to be heard by the far end user.

Primary factors affecting the coupling between the loudspeaker(s) and microphone(s) include:

- 1) directionality of the microphone(s);
- 2) directionality of the loudspeaker(s);
- 3) location of the transducers in relation to each other and reflecting surfaces such as the windows and windscreen.

3.1 Overall Loss/Loudness ratings

The overall international connection involving PLMNs and the PSTN should meet the overall loudness rating (OLR) limits in ITU-T Recommendation G.111. The national parts of the connection should therefore meet the send and receive loudness rating (SLR, RLR) limits in ITU-T Recommendation G.121.

For the case where digital routings are used to connect the PLMN to the international chain of circuits, the SLR and RLR of the national extension will be largely determined by the SLR and RLR of the PLMN. The limits given below are consistent with the national extension limits and long term objectives in CCITT Recommendation G.121.

The SLR and RLR values for the PLMN apply up to the POI. However, the main determining factors are the characteristics of the MS, including the analogue to digital conversion (ADC) and digital to analogue conversion (DAC). Hence, in practice, it will be convenient to specify loudness ratings to the Air Interface. For the normal case, where the PLMN introduces no additional loss between the Air Interface and the POI, the loudness ratings to the PSTN boundary (POI) will be the same as the loudness ratings measured at the Air Interface. However, in some cases loss adjustment may be needed for interworking situations in individual countries.

These values are directly applicable to the case of an MS operating in a conventional non-mobile noise environment. Studies have shown that under the PLMN noise environment, speech levels are likely to be higher. Hence, in order to avoid clipping in the speech transcoder, the value of SLR may need to be increased.

NOTE: In [51] 3GPP TS 51.010, measurement of SLR and RLR for handset MS is specified using sinusoidal test frequencies. This may not be the optimum method of measuring the loudness ratings because of the adaptive characteristics of the GSM speech transcoders. However the actual measurement is only performed over the linear portion of the MS. When developing the subsequent test methods for handsfree MS, in annex B and annex C, it was decided to use the artificial voice described in ITU-T Recommendation P.50, to measure send and receive sensitivities.

3.1.1 Connections with handset MSs

Overall Loss/Loudness ratings shall be as specified in [49], 3GPP TS 26.131.

For a dual mode GSM/3GPP telephone compliance shall be checked according to the procedures described in [50], 3GPP TS 26.132.

For a single mode GSM MS conformance shall be checked according to either the procedures described in [51] 3GPP TS 51.010 or the procedures described in [50] 3GPP TS 26.132.

3.1.2 Connections with handsfree MSs

Overall Loss/Loudness ratings shall be as specified in [49], 3GPP TS 26.131.

For a dual mode GSM/3GPP telephone as well as a single mode GSM MS compliance shall be checked according to the procedures described in [50], 3GPP TS 26.132.

3.1.3 Connections with headset MSs

Overall Loss/Loudness ratings shall be as specified in [49], 3GPP TS 26.131.

For a dual mode GSM/3GPP telephone as well as a single mode GSM MS compliance shall be checked according to the procedures described in [50], 3GPP TS 26.132.

3.2 Stability Loss

The stability loss presented to the PSTN by the PLMN at the POI shall be as specified for the stability loss presented to the PSTN by the 3GPP network in [49], 3GPP TS 26.131.

For a dual mode GSM/3GPP telephone as well as a single mode GSM MS compliance shall be checked according to the procedures described in [50], 3GPP TS 26.132.

3.3 Delay

3.3.1 General

A significant propagation time between the two ends of a connection causes difficulties in conversation over the connection. This arises from two causes. Firstly, the signal is reflected back from the distant end causing an echo to the talker (this is considered in subclause 3.4). Secondly, even if ideal echo control were achieved, the delay between a user talking and receiving a reply from the user at the distant end of the connection could cause conversational difficulty.

PLMNs will be connected to the PSTN at a point where present planning rules allow for a delay of less than 18 ms (see ITU-T Recommendation G.114 subclause A.2 a). The delay within the PLMN will greatly exceed this. If unacceptable circuit delays are not to be experienced by users, action will have to be taken when planning routes or during call set-up.

3.3.2 Sources of delay

3.3.2.1 Elements of the PLMN that cause delay

The delay of the PLMN is made up of the following elements:

- 1) speech transcoding delay;
- 2) radio channel coding delay;
- 3) PLMN network delay (i.e. fixed elements such as multiplexing, propagation, switching, echo control);
- 4) speech processing for echo cancelling and noise reduction in Handsfree Mode.

3.3.2.2 Elements of the PSTN that cause delay

ITU-T recommendation G.114 identifies various elements present in some PSTN connections which cause delay. These include:

- 1) coaxial, radio and optical fibre terrestrial transmission systems;
- 2) geostationary satellites;
- 3) digital speech interpolators;
- 4) digital exchanges (see also ITU-T recommendation Q.551);
- 5) echo cancellers.

3.3.3 Effects of delay

Some recent studies have suggested that under ideal conditions, i.e.:

- 1) effective control of all echoes without clipping by the use of good echo cancellers;
- 2) low background noise leading to an absence of perceptible noise contrast;
- 3) low distortion of transmitted signals;
- 4) ideal loudness ratings.

Users can tolerate a circuit delay well in excess of 400 ms (currently the maximum delay recommended in ITU-T Recommendation G.114). Other studies indicate that the difficulty caused by circuit delay increases when impairments, such as imperfect echo control caused by echo suppressers, clipping and noise contrast, are present.

However, the mobile environment is very harsh, with high background noise levels and distortion from the speech transcoder. In particular, the use of acoustic echo suppression could give rise to severe speech clipping and noise contrast. Also the operation of the voice switching used with DTX will give impairments similar to those caused by echo suppression. All subjective tests performed with echo suppressers indicate that, because of the increased effect of clipping with increased delay, the difficulty experienced by users increases rapidly with delay. According to curve 2 of figure A.1 of ITU-T Recommendation G.114, the percentage of users experiencing difficulties with echo suppressers reaches 20% with a delay of 150 ms rising to 40% with a delay of 300 ms. ITU-T Recommendation G.114 annex A details the test conditions under which this curve was derived and it concludes that connections with more than 300 ms can only be used by very disciplined users who are aware of the problems involved in such a connection. However, recent work has indicated that delays of up to 500 ms can be used satisfactorily, provided that effective echo cancellation is incorporated in the link.

3.3.4 Allocation of delay to the PLMN

3.3.4.1 Allocation of delay to the PLMN when using a full rate system

Taking account of Recommendations on the separate factors described in subclause 3.3.2.1, the maximum both-way in the PLMN between the MRP/ERP and the Point of Interconnection (see figure 1) will be 180 ms. In the case that the transcoder is positioned outside the BTS, the maximum distance between the POI and the furthest border of the cell controlled by the BTS is limited by a one-way propagation delay of 1,5 ms (approximately 300 km). If the transcoder is positioned at the BTS, the limit is 6,5 ms (approximately 1 300 km). These limits may be subject to increase resulting from savings made in the overall network.

3.3.4.2 Allocation of delay to the PLMN when using a half rate system

If it is assumed that the speech quality associated with the half rate system is the same as the full rate system (considering both the speech transcoder and the radio sub-system), then in order to achieve the same overall transmission quality, the maximum delay within the PLMN should be maintained at 180 ms.

3.3.5 Delay of various network configurations

3.3.5.1 National and international connections with no echo control in the PSTN (reference configurations A)

Reference configurations A (see figure 4) contain no echo control in the PSTN because present planning rules require the use of echo control devices only when the PSTN delay between two fixed PSTN users exceeds 25 ms. This leads to a maximum PSTN delay of 22 ms from the point of interconnection to the PLMN (see subclause 3.4.2).

3.3.5.2 National and international connections with echo control in the PSTN (reference configurations B)

Reference configurations B (see figure 5) contain echo control in the PSTN because present planning rules require their use when the PSTN delay between PSTN users exceeds 25 ms. However, action may have to be taken by administrations when planning routes or at call set-up to limit the maximum delay.

Subclause 3.3.3 describes how the impairments from the harsh mobile environment when coupled with delay can give rise to difficulty. If very good cancellation of both electrical and acoustic echo can be achieved and there are no sources of speech clipping or noise contrast either in the PLMN or the PSTN part of the connection, the circuit delay should be kept below 400 ms. This means that every attempt should be made to avoid mobile to mobile calls via satellite (expected delay > 440 ms).

If acoustic echo suppression is used or DTX is enabled, or there is any other source of clipping or noise contrast present in the PSTN, the additional distortion introduced makes it desirable to avoid any satellite routing whenever possible in order to keep the delay below 300 ms.

3.3.5.3 Connections where re-routing leads to a significant increase in transmission path length (reference configurations C)

A number of possible combinations of re-routing are described by reference configurations C (see figure 6), all of which increase the path length and hence the delay and some of which increase the number of impairments in the network.

These routings are likely to cause severe degradation to the quality of the connection and may result in significant difficulty, particularly when the connection contains one or maybe more satellite links.

These connections should be avoided in network planning and, if this is not possible, then the facilities of Signalling System No. 7 should be used to control the routing of the call at call set-up to minimize the effects.

3.3.6 Delay related requirements on the MS

3.3.6.1 Full rate MS

In accordance with the outline of transmission delays in various GSM system elements contained in GSM 03.05, the round trip delay in the MS shall not exceed 143,9 ms as defined in annex D.

3.3.6.2 Half rate MS

The round trip delay in the MS shall not exceed 143,9 ms as defined in annex D.

3.3.6.3 Handsfree MS

The round trip delay in the MS, including the handsfree processing stages, shall not exceed 143,9 ms + 39 ms. The 143,9 ms is as defined in annex D, the 39 ms is to allow for additional processing for handsfree.

The method of measurement is defined in annex C, subclause C.10.

3.4 Echo

3.4.1 General

There are two main sources of echo:

- 1) acoustic echo caused by the acoustic path between receive and transmit transducers;
- 2) electrical echo caused by coupling between the transmit and receive directions of transmission. The primary source of this form of echo is a two-to-four wire converter.

Electrical echo can be eliminated by the use of end-to-end four-wire transmission. Acoustic echo will be generated in all telephone instruments with the exception of carefully designed headsets.

In general, electrical echo is characterized by a short reverberation time and low dispersion while acoustic echo is likely to have a longer reverberation time and greater dispersion. The case of the acoustic echo may be further complicated by the time variant nature of acoustic echo which may be more severe in the mobile environment.

Curves showing the tolerance to echo, taking account of the relationship between the delay and the level of the echo, are given in ITU-T Recommendation G.131 figure 1/G.131. In practice, it has been found that for any connection with a delay of greater than 25 ms, some form of echo control will be required to reduce the level of the echo (ITU-T Recommendation G.131 Rule M).

With the expected maximum one-way delay in the PLMN of 90 ms, acoustic echo control will be required in the MS to reduce the echo returned to the distant end and electrical echo control will be required at the POI to reduce the echo returned to the PLMN user from the PSTN. The design of these echo control devices should be such as to provide operation in full duplex mode (as opposed to alternate mode).

The echo loss (EL) presented by the PLMN at the POI shall be as specified in the 3GPP Network in [49], 3GPP TS 26.131.

For a dual mode GSM/3GPP telephone as well as a single mode GSM MS compliance shall be checked according to the procedures described in [50] , 3GPP TS 26.132.

3.4.2 Electrical echo control in the PLMN (Reference configurations A)

The electrical echo control device at the interface with the PSTN should meet the requirements given in ITU-T Recommendation G.168, but with an end delay of 60 ms. This refers to t_d in subclause 1.3.10 of ITU-T

Recommendation G.168. The 60 ms is calculated as follows. ITU-T Recommendation G.131 states that the maximum length of connection which need not have echo control has a mean one-way propagation time of 25 ms. However, this figure is the sum of the delays of the international connection and the maximum national delays at each end of the connection. Since the interconnection of the PLMN to the PSTN is unlikely to be at a point where the PSTN delay is > 22 ms, and the dispersion may be up to 8 ms, the maximum expected end delay which the echo canceller in the MSC should expect is:

$$(22 + 8) \times 2 = 60 \text{ ms} \quad (\text{see figure 7}).$$

Certain countries on the geographical limits of a continent may need to increase this limit as there may be a proportion of connections which do not comply with ITU-T Recommendation G.131 having a mean one-way delay of greater than 25 ms and yet are not provided with echo control.

3.4.3 Acoustic echo control in the PLMN

Acoustic echo control in the PLMN shall be as specified in the 3GPP Network in [49], 3GPP TS 26.131.

For a dual mode GSM/3GPP telephone as well as a single mode GSM MS compliance shall be checked according to the procedures described in [50] , 3GPP TS 26.132.

3.4.4 Interaction between tandem echo control devices (reference configurations B & C)

On long international routes or routes containing a satellite path, network echo control devices will be present in accordance with ITU-T Recommendation G.131 Rule M. These devices will be echo suppressers or echo cancellers generally with centre clippers. The tandem connection of such devices can lead to increased clipping and, if echo suppressers are used, additional loss. It is recommended that signalling or routing means be used to avoid the tandem connections of echo control devices whenever possible (see figure 7).

3.5 Clipping

3.5.1 General

The loss of the start or the end of a speech burst is known as clipping, the main cause of which is voice switching controlled by voice activity detection. Voice switching occurs in devices within the network or within terminal devices. The following devices employ voice switching:

- 1) echo suppressers. These are generally located at an ISC at either end of a long international connection or connections using satellites;
- 2) echo cancellers with centre clippers. These are located as for the echo suppressers above. In addition, it is recommended that they be used in the MSC at the interface with the PSTN. Clipping in these devices arises from the action of the centre clipper only;
- 3) digital speech interpolators (DSI). These devices are used in circuit multiplication equipment's which are often employed on international connections;
- 4) discontinuous transmission (DTX) devices. These are located in the PLMN;

- 5) loudspeaking telephones. These are used in the PSTN and in the PLMN. It should be noted that regulations in certain countries prohibit the use of handheld MSs by drivers of moving vehicles.

3.5.2 Properties of voice switches in the PLMN

GSM 06.32 specifies the requirements for the voice activity detector used for DTX and the total clipping allowed in the MS. Any voice switching used for acoustic echo control should not exceed these limits. Information on recommended characteristics of handsfree telephones is given in clause 4 of ITU-T Recommendation P.340.

3.5.3 Problems of tandem voice switching

The effect of tandem voice switches which are not under one common control will be an increase in clipping. Moreover, under conditions of high or rapidly changing ambient noise, false detection of speech is likely to occur in the voice activity detectors in DSI equipment or network echo control devices. These devices are generally designed for constant and low levels of noise.

In order to minimize clipping, the following action should be taken:

- 1) intermediate tandem voice switching devices in the network should be either disabled by signalling means or avoided by routing means;
- 2) the voice switching for the MS for acoustic control and for DTX should be under one common control.

However, it should be noted that, in many cases, it will not be possible to exclude DSI equipment or loudspeaking telephones from the connection.

3.6 Idle channel noise (handset and headset MS)

3.6.1 Sending

The maximum noise level produced by the apparatus at the UPCM1 under silent conditions in the sending direction shall be as specified in [49] 3GPP TS 26.131.

For a dual mode GSM/3GPP telephone compliance shall be checked according to the procedures described in [50] , 3GPP TS 26.132. For a single mode GSM MS conformance shall be checked according to the procedures described in [51] 3GPP TS 51.010.

3.6.2 Receiving

The maximum (acoustic) noise level at the handset and headset MS when no signal (O-level) is received from the speech transcoder shall be as specified in [49] 3GPP TS 26.131.

For a dual mode GSM/3GPP telephone compliance shall be checked according to the procedures described in [50] , 3GPP TS 26.132.

For a single mode GSM MS conformance shall be checked according to the procedures described in [51] 3GPP TS 51.010.

3.7 Noise contrast

3.7.1 General

On any PLMN call there is likely to be continuous background noise which is present regardless of whether the users are talking or not. There may also be one or more voice-operated devices; these effectively break the circuit when there is no speech on it.

Noise contrast problems are caused by the background noise being interrupted when the circuit is broken so that the user listening on the circuit hears the background noise being continually switched on and off. This is particularly

disturbing for a user talking to a PLMN user in a moving vehicle because the background noise being modulated in this way is at a very high level. In this situation, it has been found that speech intelligibility can be impaired.

The main sources of background noise are:

- 1) background acoustic noise picked up by the microphone. For a loudspeaking telephone in a moving vehicle the speech/noise ratio can be as low as 0 dB;
- 2) idle channel noise. This includes noise generated in the transmission system (thermal noise and crosstalk) the switching system and in speech transcoders.

3.7.2 Elements of a PLMN which can cause noise contrast impairment

The following elements can cause noise contrast impairments:

- 1) the acoustic echo control device in the MS. A moving vehicle presents a very difficult environment for an echo canceller, so an echo suppresser is likely to be used (possibly in conjunction with an echo canceller). Echo suppressers contain voice-operated switches;
- 2) DTX. The transmitter switching will cause a PSTN user talking to a PLMN user to hear modulation of the mobile background noise. It will also cause the PLMN user to hear modulation of the PSTN noise. The PSTN noise will vary from connection to connection and should decrease in the future with increasing network digitalization;
- 3) the electric echo control devices protecting the PLMN user against echo returned from the PSTN. The centre clipper in this echo canceller will cause some noise modulation.

3.7.3 Reduction of noise contrast

A reduction in noise contrast:

- 1) reduces conversational difficulty, particularly for long conversations;
- 2) allows a greater tolerance on the matching of the level and spectrum of the comfort noise to the ambient noise.

NOTE: Preliminary tests in vehicles indicate that, in a constant noise environment with a handsfree MS and a signal-to-noise ratio of approximately 10 dB, a maximum level mismatch of 2 dB can be tolerated. The comfort noise spectrum was a reconstruction of the averaged medium term ambient noise spectrum.

3.7.3.1 Reduction of noise contrast by limiting the noise received by the microphone

The characteristics of the ambient noise (spectrum and level) depend on the environment in which the MS is used. As a microphone is characterized by its sensitivity and directivity, only part of this noise will enter the microphone.

A general principle for reducing noise contrast is to maximize the signal-to-noise ratio at the microphone input. This can be achieved by simultaneously increasing directivity, reducing sensitivity, and placing the microphone close to the mouth of the talker. Consequently, the implementation of the acoustic terminal will significantly affect the dynamic range of the noise contrast.

3.7.3.1.1 Headset MS

In the case of a headset and if DTX is disabled, then noise contrast will not be present since acoustic echo control (with centre clipping) is not required. If DTX is enabled, then only a small amount of noise contrast might result since the microphone would be close to the talker's mouth and would follow the movement of the talker's head, thus fulfilling the general principle described above. In the worst case, the headset is likely to give a minimum of 15 dB signal-to-noise ratio (this value is for further study).

3.7.3.1.2 Handset MS

In the case of a handset, and if DTX is disabled, then noise contrast will not be present if optimized echo cancelling techniques (without residual echo clipping) are used to control the acoustic echo (providing 46 dB EL). If DTX is enabled or acoustic echo control with centre clipping is used, then only a small amount of noise contrast might result

since the microphone would be close to the talker's mouth and would follow the movement of the talker's head, thus fulfilling the general principle described above. In the worst case, the handset is likely to give a minimum of 15 dB signal-to-noise ratio (this value is for further study).

3.7.3.1.3 Handsfree MS

In the case of a handsfree telephone and even if DTX is disabled, noise contrast will be introduced unless 46 dB EL can be provided without the use of centre clipping. This is unlikely to be achievable. As the microphone is distant from the talker's mouth, and as the talker may be moving during the conversation, the sensitivity of the microphone has to be high and directivity low. This could result in a worse case signal-to-noise ratio of 0 dB. (This value is for further study.)

The following is given as interim guidelines. In the case of a vehicle mounted handsfree MS, the characteristics of the microphone should be such as to limit the change in speech level to 5 dB for all positions of the talker while sitting.

3.7.3.2 Reduction of noise contrast by insertion of comfort noise

GSM 06.12 specifies comfort noise to be used both for acoustic echo control with centre clipping and DTX.

3.7.4 Consequence of the introduction of high comfort noise levels on other voice-operated devices

Two problems associated with other voice switching devices (e.g. DSI) may result from the introduction of high levels of comfort noise:

- 1) the high comfort noise level may be interpreted as a voice signal;
- 2) if the high level of comfort noise is detected as noise, then another source of comfort noise at a different level may be introduced downstream, thus increasing the noise contrast.

3.8 Sensitivity/frequency characteristics

3.8.1 Headset and Handset MSs

3.8.1.1 Sending

For a dual mode GSM/3GPP telephone as well as single mode GSM MS sending Sensivity/frequency characteristics shall be as specified in [49] 3GPP TS 26.131.

For a dual mode GSM/3GPP telephone compliance shall be checked according to the procedures described in [50] , 3GPP TS 26.132.

For a single mode GSM MS conformance shall be checked according to either the procedures described in [51] 3GPP TS 51.010 or the procedures described in 3GPP TS 26.132.

3.8.1.2 Receiving

For a dual mode GSM/3GPP telephone as well as a single mode GSM MS receiving Sensivity/frequency characteristics shall be as specified in [49] 3GPP TS 26.131.

For a dual mode GSM/3GPP telephone compliance shall be checked according to the procedures described in [50] , 3GPP TS 26.132.

For a single mode GSM MS conformance shall be checked according to either the procedures described in [51] 3GPP TS 51.010 or the procedures described in 3GPP TS 26.132.

3.8.2 Handsfree MS

3.8.2.1 Sending

For a dual mode GSM/3GPP telephone as well as single mode GSM MS sending Sensivity/frequency characteristics shall be as specified in [49] 3GPP TS 26.131.

For a dual mode GSM/3GPP telephone as well as a single mode GSM MS compliance shall be checked according to the procedures described in [50] , 3GPP TS 26.132.

3.8.2.2 Receiving

For a dual mode GSM/3GPP telephone as well as single mode GSM MS receiving Sensivity/frequency characteristics shall be as specified in [49] 3GPP TS 26.131.

For a dual mode GSM/3GPP telephone compliance shall be checked according to the procedures described in [50] , 3GPP TS 26.132.

3.9 Distortion (handset and headset MS)

The requirements for sending and receiving distortion shall be as specified in [49] 3GPP TS 26.131.

For a dual mode GSM/3GPP telephone compliance shall be checked according to the procedures described in [50], 3GPP TS 26.132.

For a single mode GSM MS conformance to the requirement on receiving distortion shall be checked according to the procedures described in [51] 3GPP TS 51.010. Conformance to the requirement on sending distortion shall be checked according to either the procedure described in [51] 3GPP TS 51.010 or the procedure described in [50] 3GPP TS 26.132.

3.9.1 Gain variation, sending

The requirement on gain variation, sending is applicable to single mode GSM MS only.

The gain variation relative to the gain for ARL shall remain within the limits given in table 6. For intermediate levels, the same limits for gain variation apply.

Table 6: Variation of gain with input level, sending

Sending level dB relative to ARL	Upper limit (dB)	Lower limit (dB)
13	0,5	-0,5
0	0,5	-0,5
-20	0,5	-0,5
-20	0,5	-2
-30	0,5	-2
-30	1	-
-40	1	-
-40	2	-
-45	2	-

Compliance of the gain variation in the sending direction shall be checked by the test described in annex C, subclause C.5.1.

3.9.2 Gain variation, receiving

The requirement on gain variation, sending is applicable to single mode GSM MS only.

The gain variation relative to the gain at an input level of -10 dBm₀, shall be within the limits given in table 8. For intermediate levels, the same limits for gain variation apply. The requirement is valid for sound pressures up to $+10$ dBPa. For sound pressures exceeding $+10$ dBPa at the ERP there is no lower limit requirement.

Table 8: Variation of gain with input level, receiving

Receiving level at the digital interface (dBm0)	Upper limit (dB)	Lower limit (dB)
+3	0,5	-0,5
-10	0,5	-0,5
-40	0,5	-0,5
-40	1	-1
-50	1	-1
-50	2	-2

Compliance of the gain variation in the receiving direction shall be checked by the test described in annex C, subclause C.5.2.

3.10 Sidetone (handset and headset MS)

3.10.1 Sidetone loss

A sidetone requirement is appropriate for MSs using handsets and headsets. There are separate requirements for listener sidetone (LSTR) and talker sidetone (STMR). The listener sidetone performance is considered as the major parameter affecting the user perception of the system. Though talker sidetone is important to give the user some comfort in using the equipment.

3.10.1.1 LSTR

There is no explicit requirement on LSTR, since the requirements on ambient noise rejection in combination with the requirement on STMR should suffice to ensure acceptable LSTR.

3.10.1.2 STMR

For a dual mode GSM/3GPP telephone as well as for a single mode GSM MS the Side Tone Masking Rate (STMR) shall be as specified in [49] 3GPP TS 26.131.

Where a user-controlled receiving volume control is provided, the STMR shall meet the requirement given above at the setting where the RLR is equal to the nominal value.

It is recommended that the STMR is independent of the volume control.

For a dual mode GSM/3GPP telephone compliance shall be checked according to the procedures described in [50] 3GPP TS 26.132.

For a single mode GSM MS conformance shall be checked according to the procedures described in [51] 3GPP TS 51.010.

3.10.2 Sidetone distortion

The requirement on sidetone distortion is applicable to single mode GSM MS only.

The third harmonic distortion generated by the terminal equipment shall not be greater than 10 %. Compliance shall be checked by the relevant procedures in [51] 3GPP TS 51.010.

3.11 Not used

3.12 Requirements for information tones

The PLMN should be capable of transmitting information tones generated by the PSTN conforming to I-ETS 300 245-7.

3.13 Crosstalk

3.13.1 Near and far end crosstalk

The near end or far end crosstalk ratio between two complete PLMN connections should not be less than 65 dB.

3.13.2 Go/return crosstalk

The crosstalk ratio between the go and return channels of a single PLMN connection should not be less than 55 dB. This is to avoid nullifying the effect of the electrical echo canceller at the MSC. The requirement applies for an acoustic input signal at the MRP with a measurement being made at the UPCMI in the opposite direction of transmission.

3.14 MS Ambient Noise Rejection

For a dual mode GSM/3GPP telephone as well as for a single mode GSM MS ambient noise rejection ANR shall be as specified for narrowband telephony transmission in [49] TS 26.131 Compliance shall be checked according to the procedures described in [50] 3GPP TS 26.132.

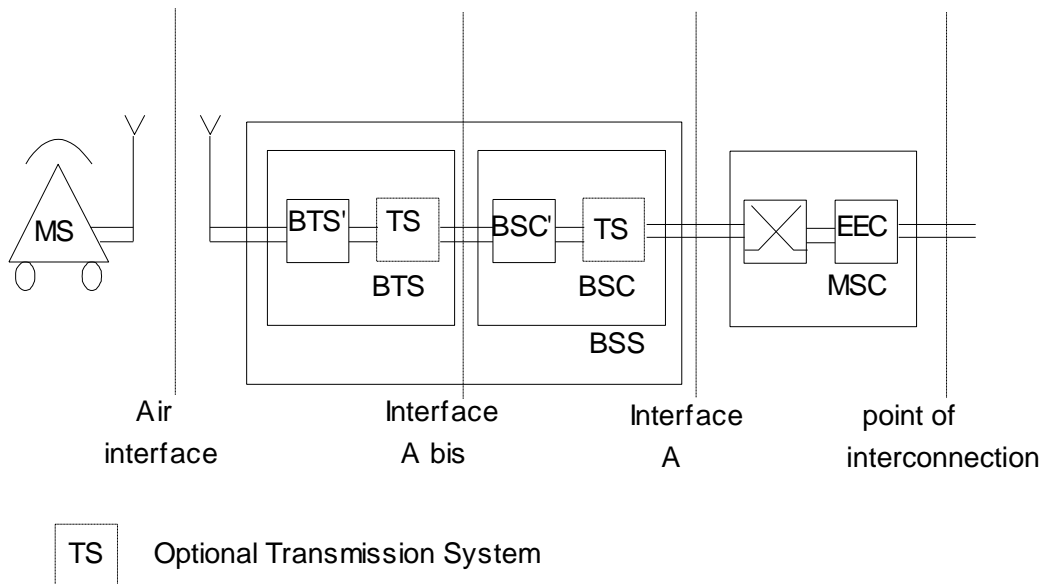

NOTE 1: For transmission planning purposes. Interfaces A and A bis are not required.
 NOTE 2: The speech transcoder may be at either the BTS or the BSC.

Figure 1: Basic Configuration for Interworking with the PSTN

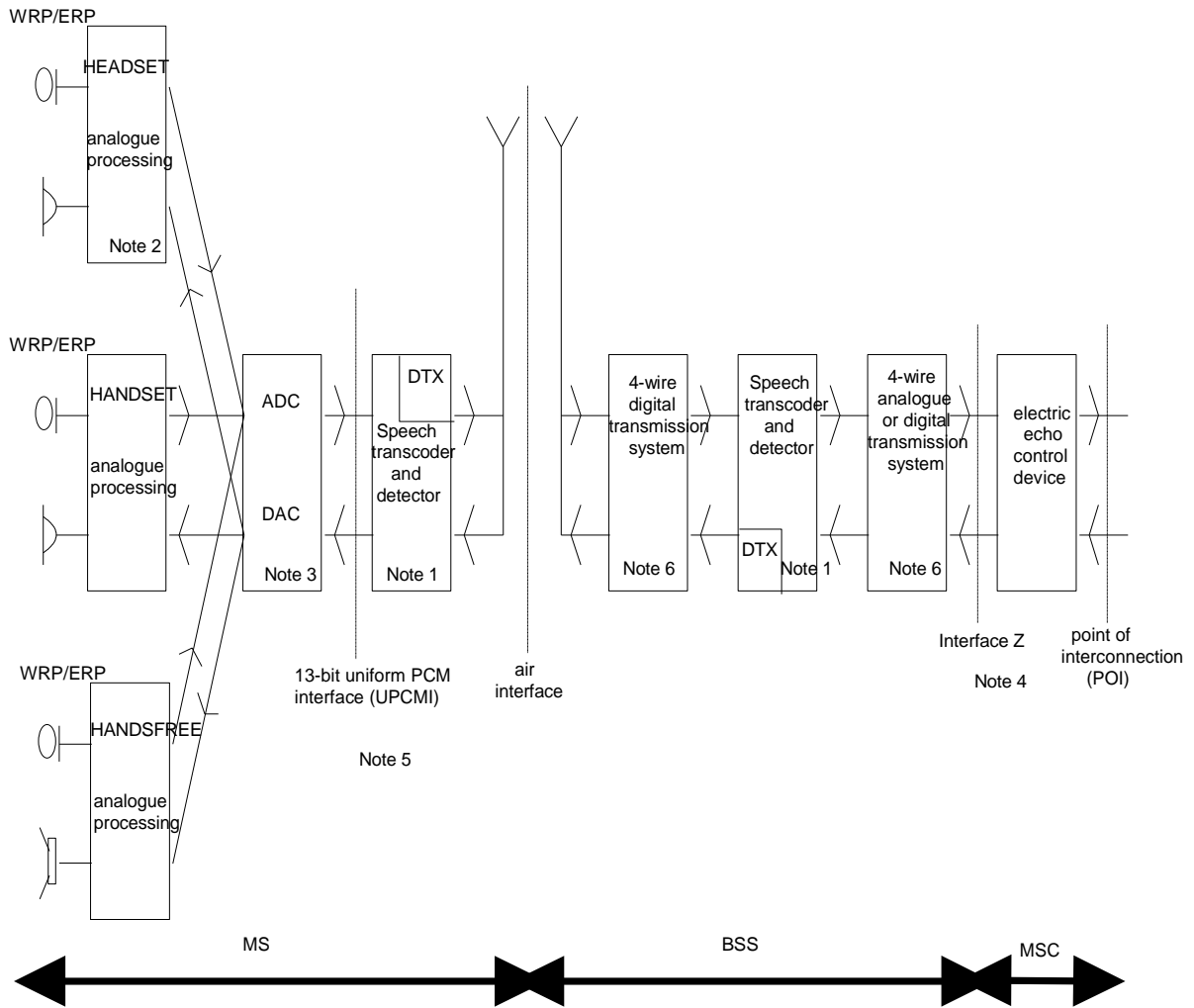

- NOTE 1: Speech detection is incorporated in the speech transcoder. Speech detection is needed to provide the function of DTX and, if required, acoustic echo control (see note 2).
- NOTE 2: Acoustic echo control may not be provided in the case of the headset.
- NOTE 3: Includes filtering.
- NOTE 4: In the case of direct MSC to MSC connections, the EEC function should not be active. The EEC device should be either disabled or not inserted in the circuit.
- NOTE 5: In single talk and in double talk, when no centre clipper is used, and in double talk only if a centre clipper is used, the level of quantizing noise introduced by the speech transcoding will effect the level of residual acoustic echo when echo cancellation techniques are used for AEC.
- NOTE 6: The transmission system need not be present.

Figure 2: PLMN System Model Used for Consideration of Transmission Planning Issues

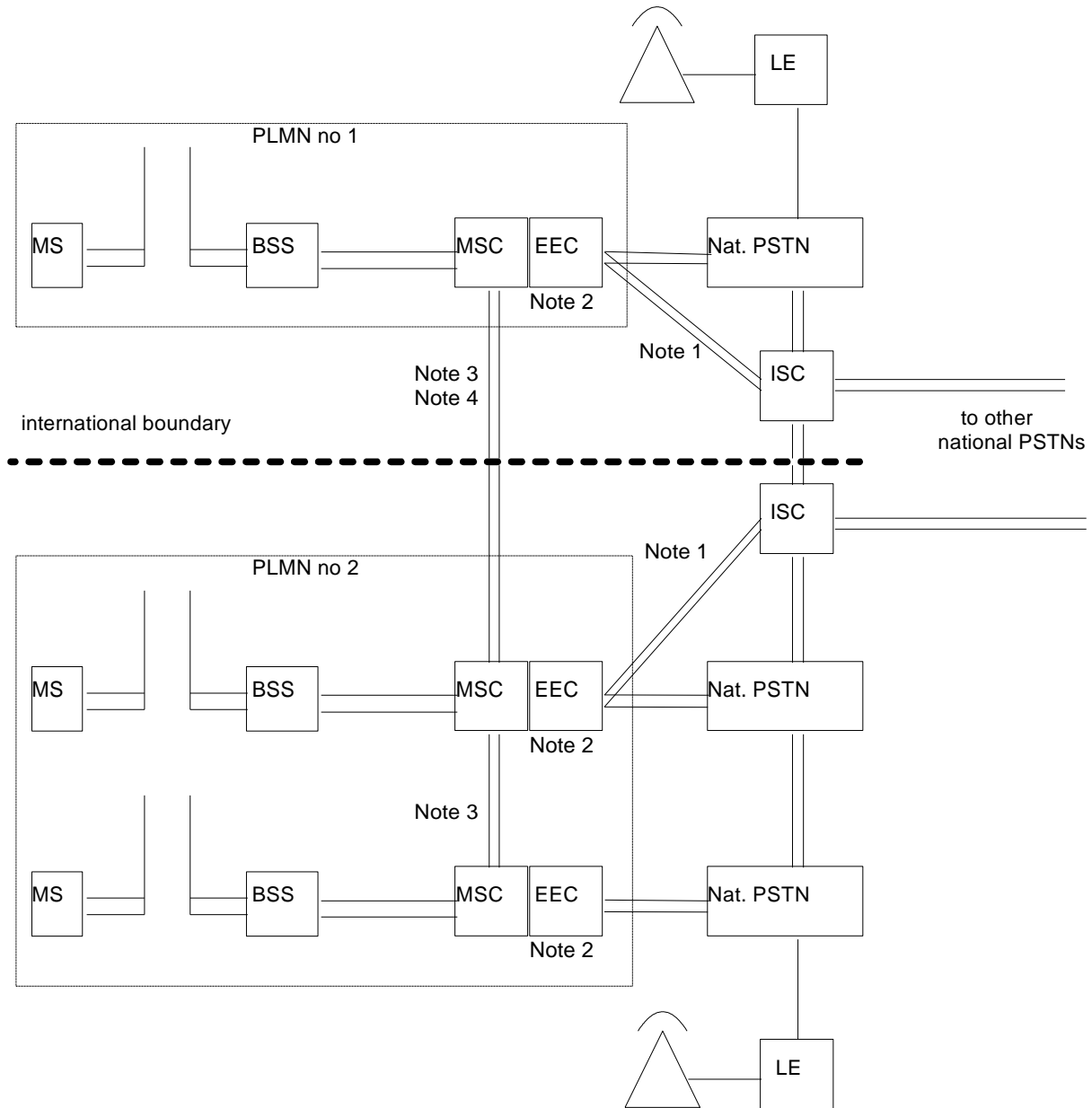

- NOTE 1: A direct link between MSC and ISC may be used in cases where Signalling System No. 7 is not provided in the PSTN or where a link via the PSTN would have excessive delay.
- NOTE 2: An echo canceller should be provided at every POI to cancel any echo returning to the PLMN from the PSTN. This is necessary because the one-way echo path back to the MS greatly exceeds 25 ms (see ITU-T Recommendation G.131).
- NOTE 3: A direct link between MSCs reduces the number of echo control devices that need to be provided and avoids the tandem connection of such devices. These direct links may be expected to have less delay than PSTN connections.
- NOTE 4: This arrangement may be provided.

Figure 3: PLMN to PSTN Interconnection Configurations

Direct routing and re-routing where the overall delay of the transmission path has not been extended and no echo control in the PSTN.

Normal configurations.

Call from PSTN to PLMN

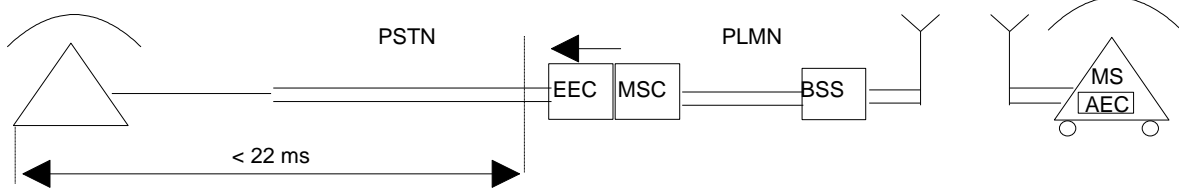

Call from PLMN to PSTN

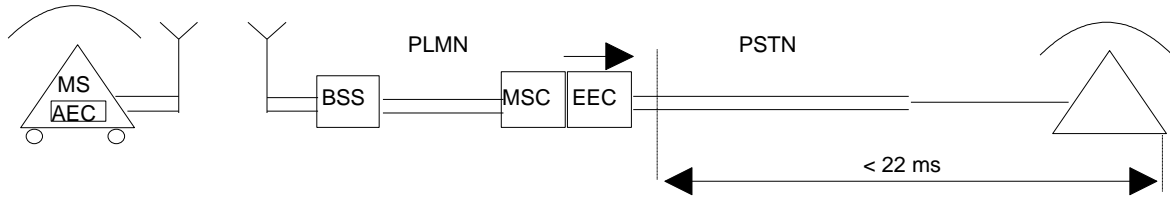

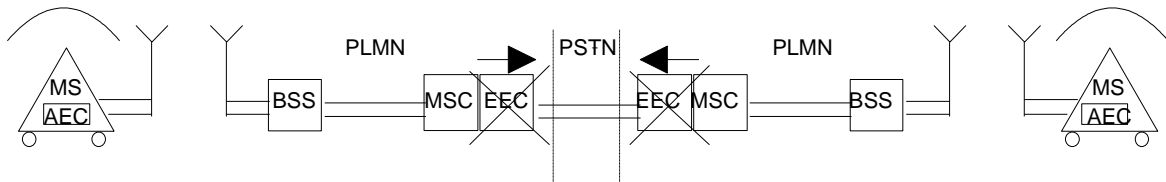

Call from PLMN to PLMN

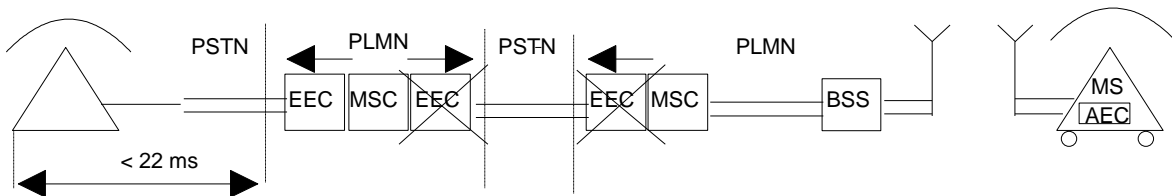

Call from PSTN to PLMN with re-route at MSC and via PSTN



Direction of signalling is left to right

-  echo control disabled
-  direction of arrow indicates the echo loop

Other configurations may exist if a call from PLMN to PLMN is re-routed at an MSC via the PSTN

Figure 4: (continued) Reference Configurations A

Where direct MSC-MSC connections exist, these configurations may apply.

Call from PSTN to PLMN with re-route via PLMN

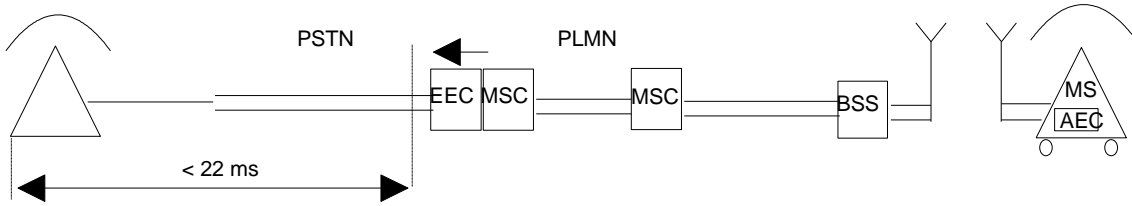

Call from PLMN to PSTN with long routeing in PLMN

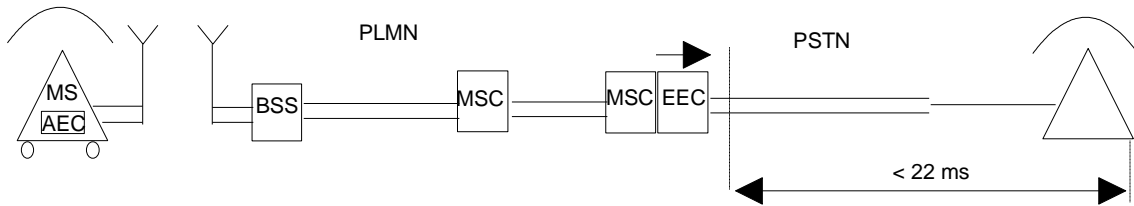

Call from PLMN to PLMN not involving PSTN

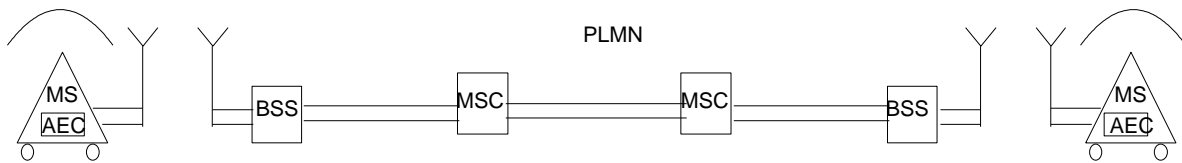

Direction of signalling is left to right

➔ direction of arrow indicates the echo loop

Figure 4: (concluded)

Direct routing and re-routings where the overall delay of the transmission path has not been extended and with echo control in the PSTN.

Normal configurations.

Call from PSTN to PLMN

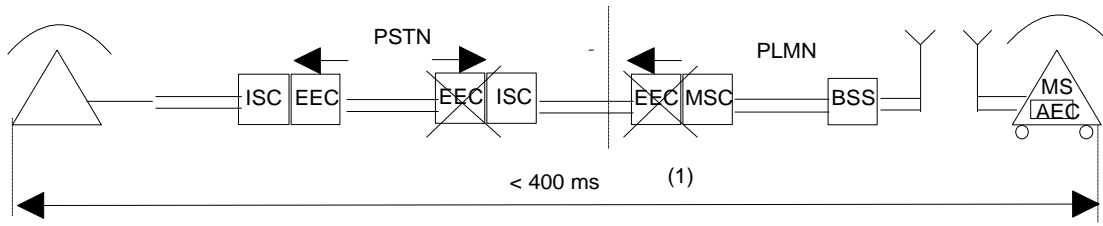

Call from PLMN to PSTN

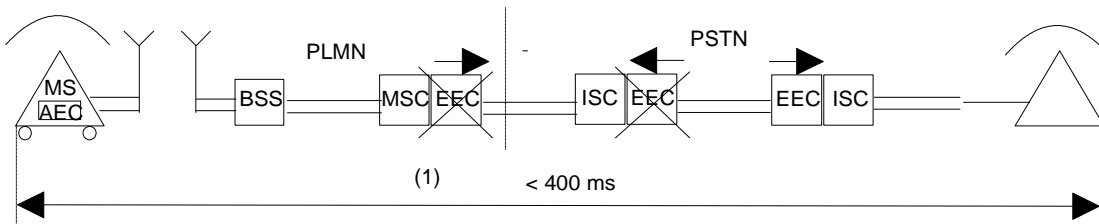

Call from PLMN to PLMN

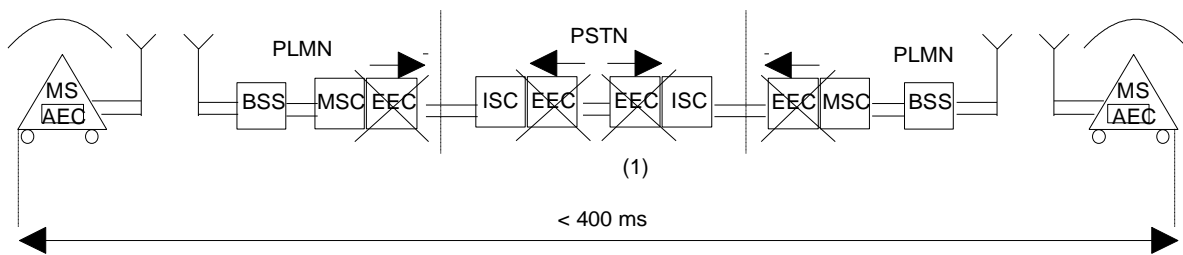

(1) see subclause 3.3.5.2

Direction of signalling is left to right

- echo control disabled
- direction of arrow indicates the echo loop

Other configurations may exist if a call from PLMN to PLMN is re-routed at an MSC via the PSTN

Figure 5: (continued) Reference Configurations B

Where direct MSC – MSC connections exist, these configurations may apply.

Call from PSTN to PLMN with re-route via PLMN

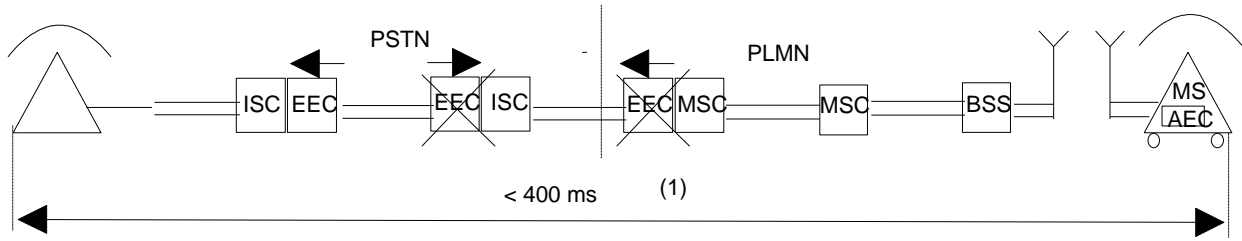

Call from PLMN to PSTN with long routing in PLMN

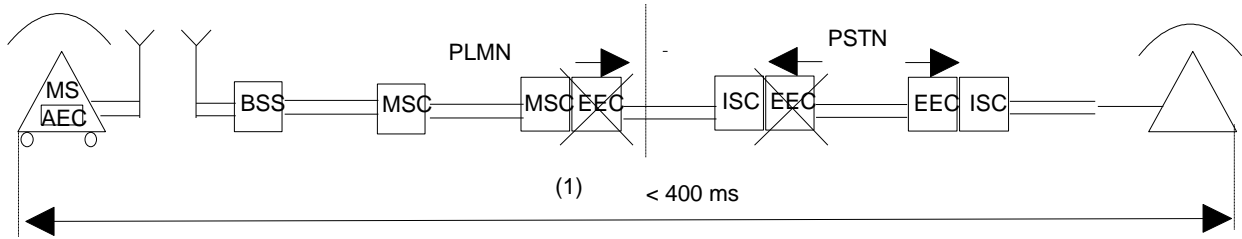

(1) see subclause 3.3.5.2

Direction of signalling is left to right



-  echo control disabled
-  direction of arrow indicates the echo loop

Figure 5: (concluded)

Re-routings where the overall delay of the transmission path has been extended beyond transmission planning limits.

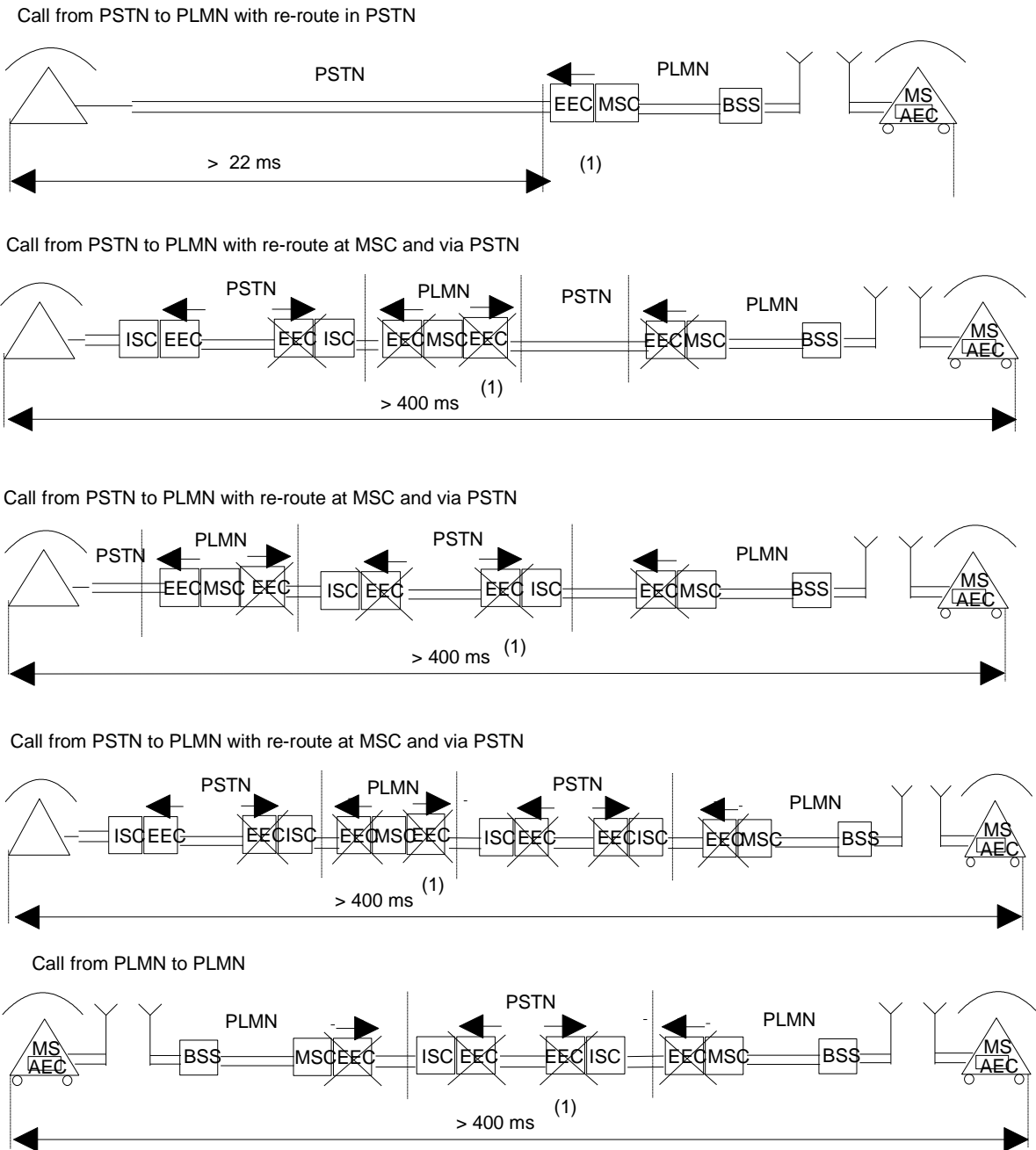
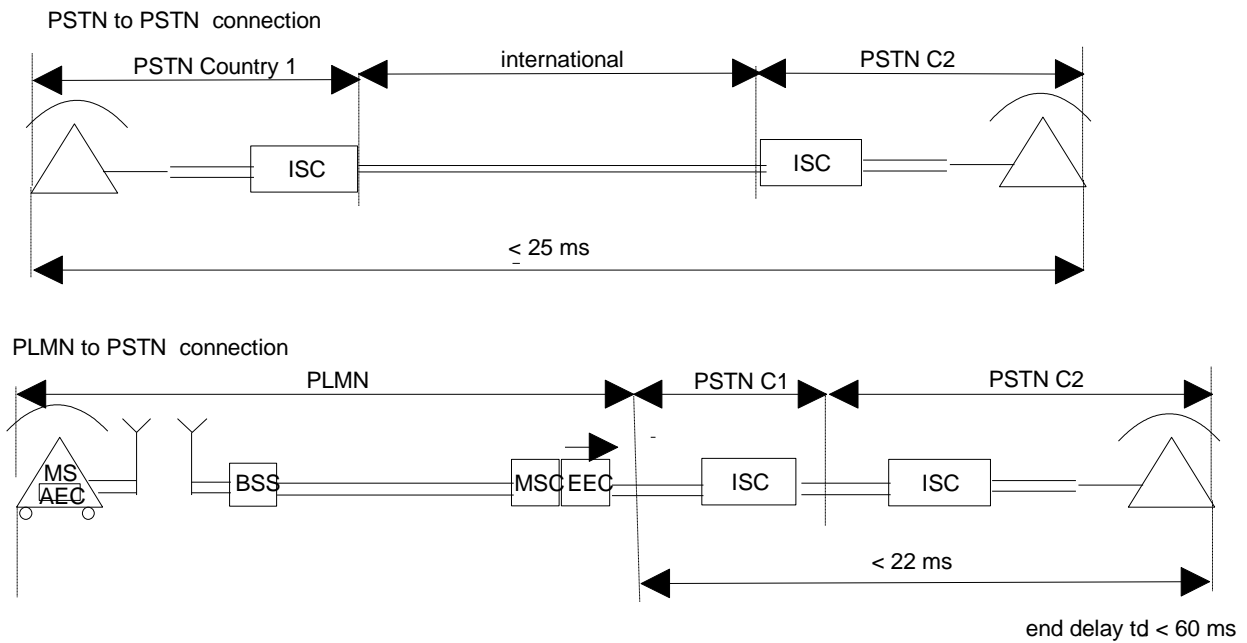

Figure 6: Reference Configuration C

No echo control in PSTN.



Echo control in PSTN.

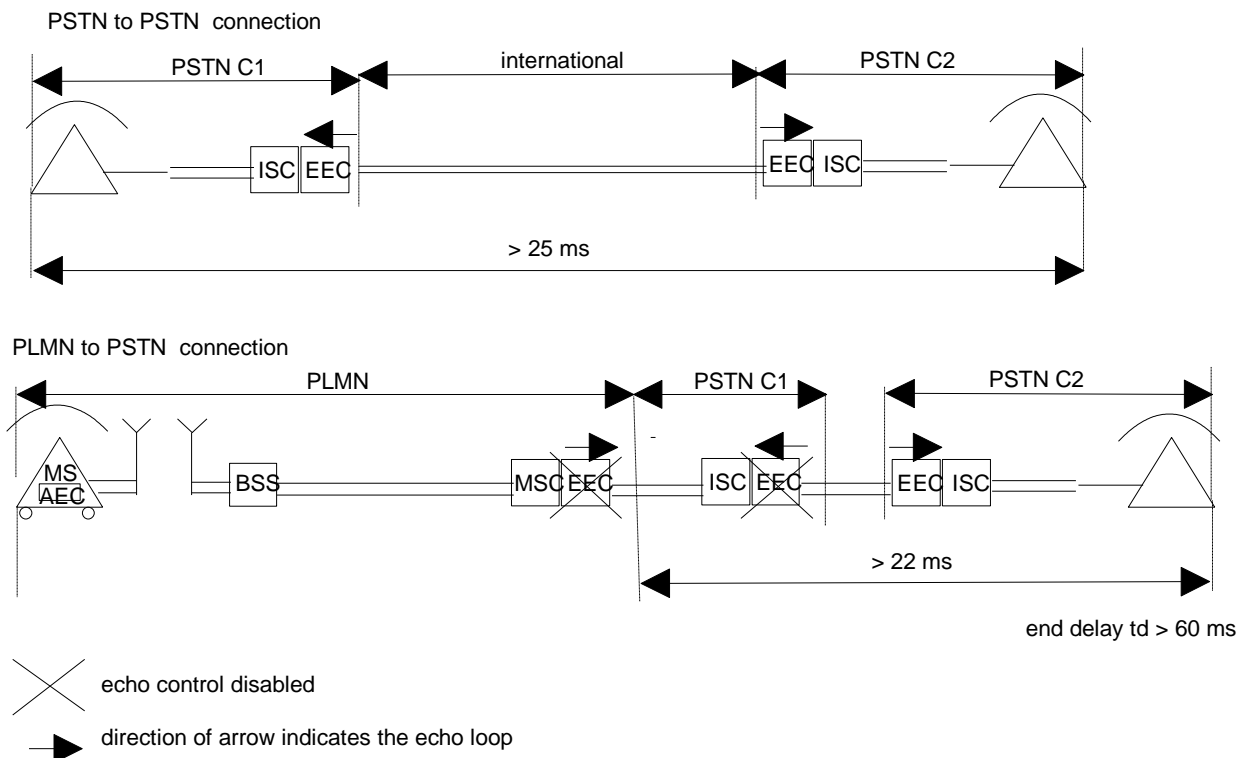

Figure 7: End Delay Requirements for PLMN EEC

Annex A (informative): Considerations on the Acoustic Interface of the Mobile Station

A.1 Handsfree MS

The handsfree MS will almost certainly require the use of non-linear processing for the acoustic echo control, the extraction of the speech from high levels of ambient noise. The implementation of these functions may well cause degradation to the overall transmission quality and cause difficulty to the distant end user especially during duplex conversation.

A.2 Handset MS

The handset MS, depending on the detailed implementation, might not require the use of non-linear processing for the acoustic echo control. Also, the position of the microphone should give a significantly improved signal-to-noise ratio, compared with a handsfree MS especially in noisy environments. This is likely to result in significantly improved transmission quality compared with the handsfree MS and easier duplex conversation.

A.3 Headset MS

The headset MS is likely to be the simplest, since with careful design, it might not require acoustic echo control. As with the handset case, the signal-to-noise ratio should be significantly improved compared with the handsfree MS especially in noisy environments. Consequently, the headset MS is likely to give the best transmission quality and easiest duplex conversation.

A.4 Inter-reaction with DTX

Because of the improved signal-to-noise ratio, both the headset MS and the handset MS are likely to give better transmission quality when DTX is enabled than that of handsfree MS.

Annex B (normative): Test considerations

Test setups for terminal acoustics shall be as specified in [50] 3GPP TS 26.132.

When DAI is used for testing of single mode GSM MS, the measurement signals shall be as specified in the relevant test-cases in [51] 3GPP TS 51.010.

Annex C (normative): Transmission requirements testing

Unless otherwise stated, testing shall be performed according to [50] 3GPP TS 26.132.

C.1 Not used C.2 Not used C.3 Not used C.4 Not used C.5 Variation of gain with input level

C.5.1 Sending

The handset is mounted at LRGP and the earpiece is sealed to the knife-edge of the artificial ear.

A sine-wave signal with a frequency in the range 1 004 Hz to 1 025 Hz is applied at the MRP. The level of this signal is adjusted until the output of the terminal is -10 dBm₀. The level of the signal at the MRP is then the ARL.

The test signal shall be applied at the following levels: -45 , -40 , -35 , -30 , -25 , -20 , -15 , -10 , -5 , 0 , 5 , 10 , 13 dB relative to ARL.

The variation of gain relative to the gain for ARL is measured.

NOTE: Selective measurement may be used to avoid the effects of ambient noise.

C.5.2 Receiving

The handset is mounted at LRGP and the earpiece is sealed to the knife-edge of the artificial ear.

A digitally simulated sine-wave signal with a frequency in the range 1 004 Hz to 1 025 Hz shall be applied at the digital interface at the following levels: -50 , -45 , -40 , -35 , -30 , -25 , -20 , -15 , -10 , -5 , 0 , 3 dBm₀.

The variation of gain relative to the gain at an input level of -10 dBm₀ shall be measured at the ERP.

NOTE: Selective measurement may be used to avoid the effects of ambient noise.

C.6 Not used

C.7 Not used

C.8 Not used

C.9 Not used

C.10 Delay for handsfree MS

C.10.1 Uplink

Configuration

The handsfree microphone is mounted physically close to the loudspeaker producing the test signal. The RF of the MS is connected to the System Simulator.

NOTE 1: For handsfree equipment fitted with multiple microphones, there must be sufficient sensitivity for one of the microphones for this test to be performed.

Procedure

The SS sets up a handsfree speech call to the MS. The SS sends a known speech like test signal (delytest.pcm) to the loudspeaker of the test system and monitors the received RF bursts.

The SS performs a correlation of the stimulus file with the received, decoded information and calculates the delay.

NOTE 2: The timing of the stimulus signal has to be related to the frame timing and the timing of the received signal has to be related to the frame in which it is received to be able to calculate the delay in the MS.

C.10.2 Downlink

Configuration

The handsfree loudspeaker is mounted physically close to the measuring microphone of the SS. The RF of the MS is connected to the System Simulator.

Procedure

The SS sets up a handsfree speech call to the MS. The SS sends a known speech like test signal (delytest.cod which is the speech coder processed version of delytest.pcm) to the MS and monitors the audio received at the loudspeaker.

The SS performs a correlation of the stimulus file with the received audio and calculates the delay.

NOTE: The timing of the received audio signal has to be related to the frame timing and the timing of the transmitted speech test signal has to be related to the frame in which it is sent to be able to calculate the delay in the MS.

C.10.3 Result

The round trip delay attributable to the MS is the sum of the delay values measured in C.10.1 and C.10.2 less the calibrated delay in the test system.

As the timing of all signals is related to air interface frame timing, the delay in the test system will only be due to operations between the timing system and the acoustic interface. This can be calibrated by running a correlation test, similar to the above, but sending the pcm file to the SS loudspeaker and measuring with the SS microphone. The delay measured by this correlation will be the sum of all the SS delays. Care should be taken in the SS to ensure that this delay is not subject to unnecessary variation.

Annex D (normative): MS delay requirement definition

D.1 Full rate MS delay requirement definition

The symbol definitions for the calculations in this clause are:

Trftx:	The time required for transmission of a TCH radio interface frame over the air interface due to the interleaving and de-interleaving (system dependent).
Ttransc:	The speech encoder processing time, from input of the last PCM sample to output of the final encoded bit (implementation dependent).
Tsample:	The duration of the segment of PCM speech operated on by the speech transcoder.
Tencode:	The time required for the channel encoder to perform channel encoding (implementation dependent).
Trxproc:	The time required after reception over the air interface to perform equalization, channel decoding and SID frame detection (implementation dependent).
Tproc:	The time required after reception of the first RPE-sample to process the speech encoded data for the full rate speech decoder and to produce the first PCM output sample (implementation dependent).
Ta/d:	Delay in the analogue to digital converter in the downlink.
Tmargin:	An allowance for system entities that are implementation dependent.
Td/a:	Delay in the digital to analogue converter in the uplink.
Tpcm:	The duration of a segment of PCM speech for the downlink processing delay.

The full rate MS speech delay in the uplink direction is the delay between an acoustic event at the MRP to the last bit of the corresponding speech frame at the antenna connector and shall not exceed:

$$\begin{aligned}
 \text{MS uplink delay} &= T_{a/d} + T_{\text{margin}} + T_{\text{sample}} + T_{\text{transc}} + T_{\text{encode}} + T_{\text{rftx}} \\
 &= 2,0 + 3,0 + 20,0 + 8,0 + 1,6 + 37,5 \text{ ms} \\
 &= 72,1 \text{ ms}
 \end{aligned}$$

The full rate MS speech delay in the downlink direction is the delay between the first bit of a speech frame at the antenna connector and the last acoustic event at the ERP corresponding to that speech frame and shall not exceed:

$$\begin{aligned}
 \text{MS downlink delay} &= T_{\text{pcm}} + T_{\text{rftx}} + T_{\text{rxproc}} + T_{\text{proc}} + T_{\text{margin}} + T_{d/a} \\
 &= 20,0 + 37,5 + 8,8 + 1,5 + 3,0 + 1,0 \text{ ms} \\
 &= 71,8 \text{ ms}
 \end{aligned}$$

The round trip delay shall therefore not exceed:

$$72,1 \text{ ms} + 71,8 \text{ ms} = 143,9 \text{ ms}.$$

D.2 Half rate MS delay requirement definition

The symbol definitions for the calculations in this clause are:

Trftx:	The time required for transmission of a TCH radio interface frame over the air interface due to the interleaving and de-interleaving (system dependent).
Ttransc:	The speech encoder processing time, from input of the last PCM sample to output of the final encoded bit (implementation dependent).
Tsample:	The duration of the segment of PCM speech operated on by the speech transcoder.
Tencode:	The time required for the channel encoder to perform channel encoding (implementation dependent).
Trxproc:	The time required after reception over the air interface to perform equalization, channel decoding and SID frame detection (implementation dependent).
Tproc:	The time required after reception of the first gain vector (GSPO) to process the speech encoded data for the half rate speech decoder and to produce the first PCM output sample (implementation dependent).
Ta/d:	Delay in the analogue to digital converter in the downlink.
Tmargin:	An allowance for system entities that are implementation dependent.
Td/a:	Delay in the digital to analogue converter in the uplink.
Tpcm:	The duration of a segment of PCM speech for the downlink processing delay.

The half rate MS speech delay in the uplink direction is the delay between an acoustic event at the MRP to the last bit of the corresponding speech frame at the antenna connector and shall not exceed:

$$\begin{aligned}
 \text{MS uplink delay} &= T_{a/d} + T_{\text{margin}} + T_{\text{sample}} + T_{\text{transc}} + T_{\text{encode}} + T_{\text{rftx}} \\
 &= 1,0 + 1,9 + 24,4 + 12,1 + 1,2 + 32,9 \text{ ms} \\
 &= 73,5 \text{ ms}
 \end{aligned}$$

The half rate MS speech delay in the downlink direction is the delay between the first bit of a speech frame at the antenna connector and the last acoustic event at the ERP corresponding to that speech frame and shall not exceed:

$$\begin{aligned}
 \text{MS downlink delay} &= T_{\text{pcm}} + T_{\text{rftx}} + T_{\text{rxproc}} + T_{\text{proc}} + T_{\text{margin}} + T_{d/a} \\
 &= 24,4 + 32,9 + 8,8 + 1,9 + 1,9 + 0,5 \text{ ms} \\
 &= 70,4 \text{ ms}
 \end{aligned}$$

The round trip delay shall therefore not exceed:

143,9 ms (see subclause 3.3.6.2).

Annex E (informative): Adaptive gain control

In noisy surroundings the speaker automatically raises his voice to compensate for the noise. The sending sensitivity can therefore be reduced, giving the same voice output to the line as under quiet conditions and at the same time reducing the output line noise level.

On the other hand the receiving sensitivity has to be increased under noisy conditions to give a better perceived sound quality.

The Sending and receiving sensitivities may be modified automatically by implementing an Adaptive gain control. The gain variation in the set corresponds to a gain in the receiving path and to a symmetrical attenuation in the sending path for increased ambient noise level.

The following table presents, for guidance and illustration only, three examples of gain variation characteristics.

Table E.1: Gain variation characteristics

	Ambient noise level	Relative Gain variation
Single threshold	between -44 and -39 dBPa(A)	8 dB
Double threshold	-44 dBPa(A)	5 dB
	-34 dBPa(A)	10 dB
Continuous variation	from -64 to -44 dBPa(A)	3 dB
	from -44 to -24 dBPa(A)	8 dB

Annex F (informative): Change History

SMG#	SPEC	CR	PHASE	VERS	NEW_VERS	SUBJECT
S17	03.50	A005	2+		5.0.0	New specification for handsfree performance
S17	03.50	A006	2+		5.0.0	Noise reduction Specification for the GSM MS.
S17	03.50	A007	2+		5.0.0	Inclusion of the possibility to use a type 3.2 leaky ear for handset tests.
S17	03.50	A008	2+		5.0.0	Update of references
s24	03.50	A011	R96	5.0.2	5.0.3	CR to 03.50 Correction of wrong reference to ITU-T Recommendation
s25	03.50	A013	R96	5.0.3	5.1.0	Removal of inconsistency in RLR for Handset and Headset MS
s27	03.50	A014	R96	5.1.0	5.2.0	Correction of reference in Section 1.1
s27	03.50				6.0.0	Release 1997 version
s28	03.50	A018	R97	6.0.0	6.1.0	Acoustic testing of MS over the air interface
s29	03.50				7.0.0	Upgrade to Release 1998 version 7.0.0
	03.50			7.0.0	7.0.1	Update to version 7.0.1 for Publication
s31	03.50			7.0.1	8.0.0	Release 1999 version 8.0.0
s32	03.50	A022	R99	8.0.0	8.1.0	Addition of a new optional artificial ear Type for acoustic tests

Change history							
Date	TSG #	TSG Doc.	CR	Rev	Subject/Comment	Old	New
03-2001	11	SP-010099	A029	2	Harmonisation of requirements on terminal acoustics in GSM and 3G	8.1.1	4.0.0
03-2001	11	SP-010099	A030	2	Harmonisation of requirements on terminal acoustics in GSM and 3G	4.0.0	5.0.0
12-2004	26				Version for Release 6	5.0.0	6.0.0
06-2007	36				Version for Release 7	6.0.0	7.0.0
03-2008	39	SP-080011	0001	1	Correction of wrong references	7.0.0	7.1.0
12-2008	42				Version for Release 8	7.1.0	8.0.0
12-2009	46				Version for Release 9	8.0.0	9.0.0
03-2011	51				Version for Release 10	9.0.0	10.0.0
09-2012	57				Version for Release 11	10.0.0	11.0.0