

3GPP TS 42.069 V11.0.0 (2012-09)

Technical Specification

3rd Generation Partnership Project; Technical Specification Group Services and system Aspects; Voice Broadcast Service (VBS); Stage 1 (Release 11)



The present document has been developed within the 3rd Generation Partnership Project (3GPP™) and may be further elaborated for the purposes of 3GPP. The present document has not been subject to any approval process by the 3GPP Organisational Partners and shall not be implemented. This Specification is provided for future development work within 3GPP only. The Organisational Partners accept no liability for any use of this Specification. Specifications and reports for implementation of the 3GPP™ system should be obtained via the 3GPP Organisational Partners' Publications Offices.

Keywords

GSM, voice, broadcast, stage 1

3GPP

Postal address

3GPP support office address

650 Route des Lucioles - Sophia Antipolis
Valbonne - FRANCE
Tel.: +33 4 92 94 42 00 Fax: +33 4 93 65 47 16

Internet

<http://www.3gpp.org>

Copyright Notification

No part may be reproduced except as authorized by written permission.
The copyright and the foregoing restriction extend to reproduction in all media.

© 2012, 3GPP Organizational Partners (ARIB, ATIS, CCSA, ETSI, TTA, TTC).
All rights reserved.

UMTS™ is a Trade Mark of ETSI registered for the benefit of its members
3GPP™ is a Trade Mark of ETSI registered for the benefit of its Members and of the 3GPP Organizational Partners
LTE™ is a Trade Mark of ETSI registered for the benefit of its Members and of the 3GPP Organizational Partners
GSM® and the GSM logo are registered and owned by the GSM Association

Contents

Foreword	4
1 Scope	5
2 References.....	5
3 Definitions and abbreviations	5
3.1 Definitions	5
3.2 Abbreviations	6
4 Description	6
5 Normal operation with successful outcome	9
5.1 Provision	9
5.2 Withdrawal	9
5.3 Network related service configuration	9
5.4 Normal operation for voice broadcast call establishment.....	9
5.5 Charging requirements	10
5.6 Security requirements	10
6 Exceptional procedures or unsuccessful outcome	10
7 Interaction with GSM services and features	10
7.1 Calling Line Identification Presentation (CLIP)	10
7.2 Calling Line Identification Restriction (CLIR)	11
7.3 Connected Line Identification Presentation (COLP)	11
7.4 Connected Line Identification Restriction (COLR)	11
7.5 Call Forwarding Unconditional (CFU).....	11
7.6 Call Forwarding on mobile subscriber Busy (CFB).....	11
7.7 Call Forwarding on No Reply (CFNRy)	11
7.8 Call Forwarding on mobile subscriber Not Reachable (CFNRc).....	11
7.9 Call Waiting (CW)	11
7.10 Call Hold (HOLD)	11
7.11 Multi-party Service (MPTY)	12
7.12 Closed User Group (CUG).....	12
7.13 Advice of Charge (AoC)	12
7.14 Barring of All Outgoing Calls (BAOC).....	12
7.15 Barring of Outgoing International Calls (BOIC)	12
7.16 Barring of Outgoing International Calls except those directed to the Home PLMN country (BOIC-exHC)	12
7.17 Barring of All Incoming Calls (BAIC)	12
7.18 Barring of Incoming Calls when Roaming outside the home PLMN country (BIC-Roam).....	13
7.19 Explicit Call Transfer (ECT)	13
7.20 enhanced Multi-Level Precedence and Pre-emption service (eMLPP).....	13
7.21 Short Message Service (SMS).....	13
7.22 Operator Determined Barring (ODB)	13
7.23 Completion of Calls to Busy Subscribers (CCBS)	13
7.24 GPRS	13
8 Interworking considerations	13
Annex A (informative): Change History	14

Foreword

This Technical Specification has been produced by the 3rd Generation Partnership Project (3GPP).

The contents of the present document are subject to continuing work within the TSG and may change following formal TSG approval. Should the TSG modify the contents of the present document, it will be re-released by the TSG with an identifying change of release date and an increase in version number as follows:

Version x.y.z

where:

- x the first digit:
 - 1 presented to TSG for information;
 - 2 presented to TSG for approval;
 - 3 or greater indicates TSG approved document under change control.
- y the second digit is incremented for all changes of substance, i.e. technical enhancements, corrections, updates, etc.
- z the third digit is incremented when editorial only changes have been incorporated in the document.

1 Scope

The present document specifies the stage one description of the Voice Broadcast Service (VBS) which allows the distribution of speech (or other signals which can be transmitted via the speech codec), generated by a service subscriber, into a predefined geographical area to all or a group of service subscribers located in this area.

The Voice Broadcast Service (VBS) is applicable to all mobile stations in a certain network and area which have the technical capability and the respective subscription to receive a VBS call.

NOTE: It is not considered as requirement that normal GSM Phase 2 mobile stations will be able to be used for this service.

The service is described from the service subscriber's and user's point of view; in particular:

- the procedure for normal operation with successful outcome;
- the action to be taken in exceptional circumstances;
- the interaction with other GSM services and features.

The present document does not deal with the Man-Machine Interface (MMI) requirements, but makes reference to the appropriate Global System for Mobile communications (GSM) specifications.

The present document defines a teleservice of the digital cellular telecommunication system GSM. Any interaction with other services and/or networks not dealt within clauses 8 or 9 are outside the scope of the present document.

2 References

The following documents contain provisions which, through reference in this text, constitute provisions of the present document.

- References are either specific (identified by date of publication, edition number, version number, etc.) or non-specific.
- For a specific reference, subsequent revisions do not apply.
- For a non-specific reference, the latest version applies. In the case of a reference to a 3GPP document (including a GSM document), a non-specific reference implicitly refers to the latest version of that document *in the same Release as the present document*.

[1] 3GPP TR 21.905: "Vocabulary for 3GPP Specifications".

[2] 3GPP TS 22.067: "enhanced Multi-Level Precedence and Pre-emption service (eMLPP); Stage 1".

[3] 3GPP TS 32.005: "Telecommunications management; Charging management; 3G call and event data for the Circuit Switched (CS) domain".

3 Definitions and abbreviations

3.1 Definitions

For the purposes of the present document, the following terms and definitions apply:

Network operator: Entity which provides the network operating elements and resources for the execution of the VBS.

Service provider: Entity which offers the VBS for subscription. The network operator may be the service provider.

Service subscriber: Mobile subscriber which subscribes to the VBS.

Voice broadcast call: An instance of the VBS initiated by a VBS subscriber. This term is used synonymously with the term "VBS call".

Group identification (group ID): A numerical classification. The maximum number of group IDs which can be defined in one PLMN depends on the maximum number of group call areas defined in this PLMN. The maximum number of group IDs and group call areas shall be 10^8 , Service subscriber shall be provided with one or up to 50 group IDs.

Dispatcher: Particular fixed line or mobile users are identified within the network as dispatchers. Dispatchers shall receive all voice broadcast calls to a certain group ID in a group call area (this shall be done automatically by the network). In addition they can initiate voice broadcast calls to a group ID in a group call area.

Dispatchers shall be connected to a voice broadcast call by means of standard links via radio or via an ISDN. They shall be called by their MSISDN or ISDN number, respectively. When dispatchers initiate voice broadcast calls, they shall call a particular MSISDN number which is related to a group ID and group call area. Dispatchers using the GSM network can be located outside of this group call area.

The identities of the dispatchers are exclusively predefined in the network by the service provider. There may be none, one or more dispatchers involved in a particular voice broadcast call.

As a mandatory network requirement, configuration of up to 5 dispatchers shall be supported. Optionally, up to a maximum of 20 dispatchers may be configured for a particular group call reference.

Destination service subscriber: Service subscriber to which the VBS call is directed.

Calling service subscriber: Service subscriber which originates the VBS call.

Calling dispatcher: Dispatcher which originates the VBS call.

Destination dispatcher: Pre-registered dispatcher to which the VBS call is directed.

Destination subscriber: Destination dispatcher(s) and/ or destination service subscriber(s) to which the VGCS call is directed.

Group call area: Predefined area composed of one or a cluster of cells, to which a particular VBS call is distributed. The maximum number of group call area IDs which can be defined in one PLMN depends on the maximum number of group IDs defined in this PLMN. The maximum number of group IDs and group call areas combined shall be 10^8 , The composition of a group call area is predefined in the network by the service provider. Changing of cell allocations in the network due to operational reasons will need an adaptation of the group call area definition. The group call area may include cells of more than one MSC area and cells of more than one PLMN.

Originator-to-dispatcher information: Information sent by the service subscriber originating a voice group call to the network during call setup for distribution to the dispatchers to be attached to the group call during call setup.

Listener: see Listening service subscriber

Listening service subscriber: Service subscriber who is listening to an ongoing voice group call.

3.2 Abbreviations

Abbreviations used in the present document are listed in 3GPP TR 21.905 [1].

4 Description

The VBS is defined in the following. Figure 1 gives an explanation of the logical concept of the VBS.

- a) The VBS enables a calling service subscriber or calling dispatcher to send speech unidirectional and simultaneously to all entitled dispatchers and to destination service subscribers belonging to a predefined group call area who have a subscription to the applicable group ID.
- b) The calling service subscriber may be any service subscriber which has subscribed to the related group ID and is entitled to establish a voice broadcast call by his subscription. The calling dispatcher may be any dispatcher who

is entitled to originate VBS calls to the related call reference.

The destination subscriber may be any service subscriber which has subscribed to the related group ID or any dispatcher who is entitled for it by his identity which is registered in the network.

- c) The broadcast call shall be established in a group call area which is comprised of one or a cluster of cells. Group call areas shall be predefined in the network by the service provider, co-ordinated by the network operator.

In case of a calling service subscriber initiating a VBS call, the group call area is uniquely identified by the actual cell in which the service subscriber resides at the moment of VBS call initialization and by the called group ID.

A calling dispatcher initiating a VBS call will be connected to a related predefined group call area. The entitlement of the dispatcher is checked by the network element responsible for the voice broadcast call management by verification of the calling identity. Since a dispatcher may be registered to more than one group call area and group ID an indication of the wanted group call area and group ID has to be given in form of a dedicated address called by the dispatcher.

- d) Destination subscribers are all destination service subscribers or a group of destination service subscribers identified by the called group ID which have their present location in the group call area, and preregistered destination dispatchers. Destination service subscribers shall be notified with the group ID, not by paging the service subscriber individually. Destination dispatchers shall be called individually with their identity.

Service subscribers which leave the group call area during an on going VBS call cease to be destination subscribers. Service subscribers which enter the group call area during an on going VBS call shall become destination subscribers within 500 ms after reception of the first notification message related to the VBS call.

- e) The calling service subscriber shall remain within the voice broadcast call until she terminates the call, loses contact with the network or leaves the group call area. The VBS call shall be terminated by the network as soon as the network has determined that the calling service subscriber has left the VBS call area.
- f) A voice group call will be considered established as soon as the originating cell in case of a service subscriber originated voice group call, or any one cell within the group call area in case of a dispatcher originated voice group call has been included.

The calling service subscriber or calling dispatcher shall be informed by the network with a suitable indication about the successful establishment of the voice broadcast call so that he can start to speak.

The network shall then continue to try to include all remaining voice group call downlink channels and alert related dispatchers not yet alerted.

- g) Authentication is mandatory at GSM call set up. To allow fast call set up in VBS authentication of the calling service subscriber or calling dispatcher at invocation may optionally be delayed.

Authentication of the destination subscriber, who has no uplink connection, is not required.

Confidentiality on the radio path is optional.

- h) Different levels of priority and pre-emption shall be applied as defined in the corresponding stage 1 description on the enhanced Multi-Level Precedence and Pre-emption service (eMLPP), 3GPP TS 22.067.
- i) A number of voice broadcast calls may exist simultaneously intended for different groups of destination subscribers in the same group call area.

Parallel voice broadcast calls are possible to the same group of destination subscribers in different, possibly overlapping group call areas.

- j) VBS shall also be provided in case of roaming. For this, certain group Ids shall be defined as supra-PLMN group Ids which have to be co-ordinated between the network operators and which shall be known in the networks and in the SIM. A service subscriber which is entitled by his subscription to establish voice broadcast calls while roaming shall only be able to use supra-PLMN group Ids in case of roaming.
- k) For certain levels of priorities an acknowledgement of receipt of a voice broadcast call can be required as an application option (e.g. for railway emergency calls) from all or from nominated destination service subscribers (the nomination is recorded on the SIM). The acknowledgement itself shall be performed at the end of the voice

broadcast call. The acknowledgement shall indicate the time the reception started and the time the reception terminated. The acknowledgement has to be given to a predefined recipient.

- l) It shall be possible for a service subscriber to activate or deactivate the voice broadcast reception for different group IDs. The selection list is stored on the SIM corresponding to the subscribed group IDs. It shall be possible to prohibit the deactivation of group IDs used for high priority voice broadcast calls.

Mobile users that are configured as dispatchers and which are registered in the network for a certain voice broadcast call and which have also a subscription for VBS with the same group ID as the voice broadcast call for which they are dispatcher shall deactivate this group ID when they are located in the corresponding group call area in order to avoid conflicts between paging for the dispatcher and notifications for the group ID.

- m) The calling service subscriber may specify, at call setup, information to be presented at call setup to the dispatchers. This information is sent as originator-to-dispatcher information to the network, and sent as UUS1 by the network to the dispatchers in the message for call setup. For normal call setup, the information is subject to the same constraints as UUS1 information in the setup of a point-to-point call. For fast setup, the information is restricted to 12 digits (with leading zeros); inclusion of originator-to-dispatcher information at fast setup is only possible if the mobile station has a valid TMSI. It is a network option to support originator-to-dispatcher information, or to ignore it. The inclusion of originator-to-dispatcher information in the VBS call setup is not subject to provision or withdrawal.

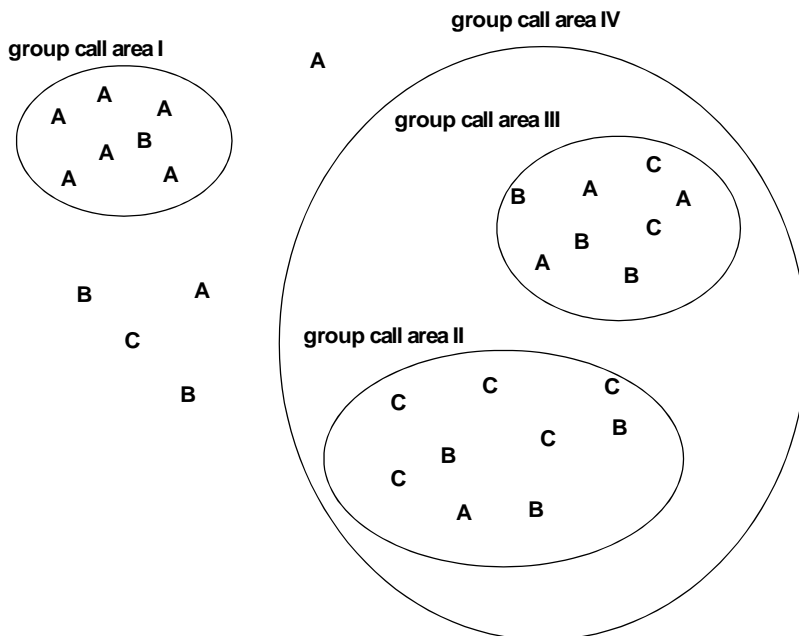
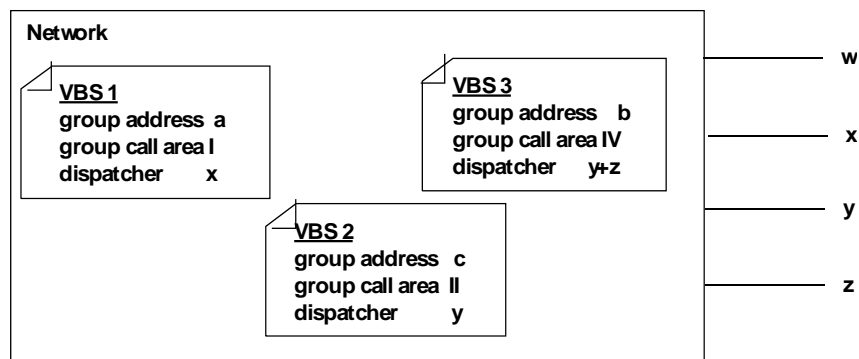

NOTE: VBS1, VBS2, VBS3 = particular voice broadcast calls with the attributes preregistered in the network. A, B, C, D = service subscriber with group ID a, b, c or d, respectively.

I, II, III, IV = group call areas.

w, x, y, z = dispatchers connected via normal GSM links or external networks.

Figure 1: Logical concept of the VBS

5 Normal operation with successful outcome

5.1 Provision

The VBS is provided to be used by a service subscriber after prior arrangements with the service provider. The provision includes the assignment of group IDs to the service subscriber. A subscription shall not provide more than 50 group IDs to the service subscriber.

The service can be offered with two subscription options:

Subscription option	Value
- subscriber has the capability of initiating voice broadcast calls	No Yes;
- subscriber has the capability to initiate voice broadcast calls in case of roaming	No Yes.

5.2 Withdrawal

The VBS is withdrawn at the service provider's request or for administrative reasons.

5.3 Network related service configuration

The network related service configuration defines the attributes of a particular voice broadcast call which shall be pre-registered in the network by the service provider. This is not related to one specific service subscriber.

The attributes of a particular broadcast call are group ID, group call area composition, a list of dispatcher identities to be connected to this area, a list of dispatchers allowed to initiate voice broadcast calls to this area, the broadcast call reference identity which shall be used in case of COLP (see subclause 7.3) and recipient identities to which an optional acknowledgement can be routed. Changes to the group call area composition shall be co-ordinated with the network operator.

5.4 Normal operation for voice broadcast call establishment

The VBS service shall be automatically initiated by the network when a calling service subscriber or calling dispatcher dials a particular short code or address at call set-up.

On successful initiation of the VBS, the voice broadcast call shall be established between the calling service subscriber or calling dispatcher and the destination subscribers. The destination subscribers are:

- all destination service subscribers at any time during the voice broadcast call with the corresponding active group ID when located in the group call area, where the group call area is uniquely defined by:
 - the location (radio cell) of the calling service subscriber at invocation and group ID if the call is originated by a calling subscriber is a service subscriber;
 - the addressed group call area if the call is originated by a calling dispatcher;
- the preregistered destination dispatchers related to that group call area and group ID.

The calling service subscriber or calling dispatcher shall be informed by the network with a suitable indication about the successful establishment of the voice broadcast call so that the user can start to speak.

The call can be released by the calling service subscriber or by the calling dispatcher or by the network (e.g. in case of a higher priority call) or by an entitled dispatcher predefined in the network.

Destination subscribers leaving the voice broadcast call for any reason shall not release the on going voice broadcast call.

5.5 Charging requirements

Normal event data according to 3GPP TS 32.005 shall be recorded as a network option related to calling subscriber or related to all VBS calls to one group ID in a specific group call area. In addition data to be passed to the anchor MSC for charging purposes is the resources (i.e. cell identities) used during a call.

5.6 Security requirements

VBS shall be able to support over-the-air ciphering in order to provide confidentiality protection to group calls.

VBS ciphering is an operator's option.

VBS shall provide means such that only a legitimate service subscriber is able to participate in a ciphered VBS call when the operator requires confidentiality protection for the group call. To include a subscriber into a ciphered voice group the required group data shall be stored on the USIM. Storing these group data on the USIM may be done e.g. during the USIM personalisation process or via OTA (over-the-air) provisioning.

A pre- Rel-6 VBS capable mobile shall be able to participate in an un-ciphered group call, if it is part of that group.

6 Exceptional procedures or unsuccessful outcome

If a service subscriber wants to establish a voice broadcast call while not subscribed to the service or the network cannot provide the service for some reason, an indication shall be provided to the calling service subscriber to notify him with the reason of failure.

If a dispatcher wants to establish a voice broadcast call while not entitled to do it or the network cannot provide the service for some reason, the call shall be rejected. The network shall give an appropriate indication to calling dispatchers who are GSM subscribers.

A voice group call shall be considered established as soon as the originated cell in case of a service subscriber originated broadcast call or any one cell within the group call area in case of a dispatcher originated broadcast call has been included. If this cannot be achieved within a specified time the call will be released.

If a cell is excluded from the group call area because of pre-emption, the voice broadcast call is maintained as long as the calling subscriber is not pre-empted.

7 Interaction with GSM services and features

7.1 Calling Line Identification Presentation (CLIP)

If CLIP is applied, the broadcast call reference – including the group call area ID and the group ID – shall be presented to the destination dispatchers. In addition the subaddress field of the calling party may be used to identify the calling service subscriber or calling dispatcher to the destination dispatchers.

The receiving mobile stations of the destination subscribers shall display the paged group ID regardless the destination subscribers have a subscription to CLIP.

7.2 Calling Line Identification Restriction (CLIR)

CLIR shall be supported.

The network shall have the possibility to override CLIR or reject the request to establish a voice broadcast call for a calling service subscriber or calling dispatcher who has CLIR activated.

7.3 Connected Line Identification Presentation (COLP)

If COLP is applied, the broadcast call reference - including the group call area ID and the group ID - shall be presented to the calling dispatcher. No destination subscriber identities will be presented.

Calling service subscribers receive the broadcast call reference via standard broadcast call setup messaging. COLP therefore does not apply to service subscribers.

7.4 Connected Line Identification Restriction (COLR)

COLR is not applicable to voice broadcast calls.

7.5 Call Forwarding Unconditional (CFU)

CFU is not applicable to voice broadcast calls of service subscribers when activate and operative, i.e. CFU shall be ignored.

CFU is applicable for dispatchers, i.e. voice broadcast calls are forwarded by CFU.

7.6 Call Forwarding on mobile subscriber Busy (CFB)

CFB is not applicable to voice broadcast calls of service subscribers with CFB active and operative.

CFB is applicable for dispatchers if the voice broadcast call does not have a higher priority than the present call.

7.7 Call Forwarding on No Reply (CFNRy)

CFNRy is not applicable to voice broadcast calls of service subscribers with CFNRy active and operative.

CFNRy is applicable for dispatchers, i.e. voice broadcast calls are forwarded by CFNRy.

7.8 Call Forwarding on mobile subscriber Not Reachable (CFNRc)

CFNRc is not applicable to voice broadcast calls of service subscribers with CFNRc active and operative.

CFNRc is applicable for dispatchers, i.e. voice broadcast calls are forwarded by CFNRc.

7.9 Call Waiting (CW)

CW is not applicable for service subscriber. Instead, as a network option, a notification of paging for other calls shall be given to the service subscribers involved in the voice broadcast call.

CW is applicable for dispatchers.

7.10 Call Hold (HOLD)

Call hold is not applicable for service subscribers. For handling of parallel voice broadcast calls to the same destination

subscriber see item i) of clause 4.

A calling service subscriber cannot leave the voice broadcast call without releasing the call.

The acceptance of a voice broadcast call by a service subscriber while being in a point-to-point call shall release the point-to-point call. The release will be invoked by the mobile station.

If a voice broadcast call is requested by a service subscriber while being in a point-to-point call, the point-to-point call shall be released. The release will be invoked by the mobile station.

Call hold is applicable for dispatchers.

7.11 Multi-party Service (MPTY)

MPTY is not applicable for service subscribers.

MPTY is applicable for dispatchers, subject to the capabilities of the UE and the serving network.

7.12 Closed User Group (CUG)

CUG is not applicable for service subscribers. Consequently, being a member of a CUG has no impact on receiving voice broadcast calls.

CUG is applicable for dispatchers. Therefore a dispatcher who is a member of a CUG may be excluded from originating, joining and receiving broadcast calls subject to the capabilities of the UE and the serving network.

7.13 Advice of Charge (AoC)

AoC can be provided to the calling subscriber as network option.

7.14 Barring of All Outgoing Calls (BAOC)

BAOC is applicable, if subscribed to, with the possible exception of high priority voice broadcast calls.

7.15 Barring of Outgoing International Calls (BOIC)

BOIC is not applicable for voice broadcast calls of service subscribers.

BOIC is applicable for dispatchers.

7.16 Barring of Outgoing International Calls except those directed to the Home PLMN country (BOIC-exHC)

BOIC-exHC is not applicable for voice broadcast calls of service subscriber.

BOIC-exHC is applicable for dispatchers.

7.17 Barring of All Incoming Calls (BAIC)

BAIC is not applicable for voice broadcast calls to service subscribers.

BAIC is applicable for dispatchers.

7.18 Barring of Incoming Calls when Roaming outside the home PLMN country (BIC-Roam)

BIC-Roam is not applicable for voice broadcast calls to service subscribers.

BIC-Roam is applicable for dispatchers.

7.19 Explicit Call Transfer (ECT)

ECT is not applicable for service subscribers.

ECT is applicable for dispatchers, subject to the capabilities of the UE and the serving network.

7.20 enhanced Multi-Level Precedence and Pre-emption service (eMLPP)

Different priorities with corresponding set-up procedures are applicable as defined in the stage 1 description on eMLPP in 3GPP TS 22.067.

7.21 Short Message Service (SMS)

Sending and reception of short messages is not possible for destination service subscribers.

7.22 Operator Determined Barring (ODB)

Same as for subscriber controlled barring.

7.23 Completion of Calls to Busy Subscribers (CCBS)

The CCBS supplementary service is only applicable for dispatchers and not for VBS service subscribers.

If a new terminating p-t-p call is set up to a dispatcher who is busy because of an active VBS call, it shall be possible to allow the calling party to apply the CCBS service. If the dispatcher initiates a VBS call and the called broadcast ID has been active, then the dispatcher shall be connected to the ongoing VBS call.

7.24 GPRS

Depending on the capabilities of the UE it shall be possible for the mobile dispatcher, for the calling service subscriber as well as for the listening service subscribers to use GPRS in parallel to the VBS, subject to the capabilities of the serving network.

8 Interworking considerations

No specific requirements are identified.

Annex A (informative): Change History

TSG#	TSG doc	WG doc	Spec	CR	Rev	Ph	Cat	Title	Old vers	New vers	WI
S#28		May 2000	02.69			R99		Specification upgrade to Release 1999 version 8.0.0	7.0.0	8.0.0	
S#32		June 1999	02.69	A014		R00		Introduction of Originator-to-dispatcher information into VBS	8.0.0	9.0.0	
			02.69 / 42.069					Conversion to 3GPP TS format	02.69 v9.0.0	42.069 v4.0.0	-
SP-10	SP-000550		42.069	001		Rel-4	A	Correction of implementation of Clarification of interaction with CCBS service	4.0.1	4.1.0	Correct
SP-16	SP-020267	S1-021043	42.069			Rel-5		Updated from Rel-4 to Rel5	4.1.0	5.0.0	
	2002-07					Rel-5		Correction to version number	5.0.0	5.0.1	
SP-25	SP-040508	S1-040644	42.069	002	-	Rel-6	B	Addition of optional over-the-air ciphering for VBS	5.0.1	6.0.0	SECGKY V
SP-28	SP-050210	S1-050476	42.069	005	-	Rel-6	A	Correction on the use of calling subscriber and destination subscriber	6.0.0	6.1.0	ASCII
SP-31	SP-060028	S1-060197	42.069	0006	-	Rel-7	C	Modification to setup to remove the need for full conditions	6.1.0	7.0.0	TEI7
SP-31	SP-060027	S1-060211	42.069	0007	-	Rel-7	C	Increasing maximum number of dispatchers to 20 as an optional requirement	6.1.0	7.0.0	EGCS
SP-34	SP-060775	S1-061319	42.069	0008	-	Rel-8	F	Correction on the use of listening service subscriber	7.0.0	8.0.0	TEI8
SP-34	SP-060759	S1-061411	42.069	0009	-	Rel-8	F	Support of the use of GPRS for individual VBS subscribers in parallel to an active broadcast call	7.0.0	8.0.0	EGCS
SP-37	SP-070644	S1-071103	42.069	10	1	Rel-8	C	TCRT: Clarification of interactions with supplementary and other GSM services	8.0.0	8.1.0	TEI8
SP-46	-	-	-	-	-	-	-	Updated to Rel-9 by MCC	8.1.0	9.0.0	
2011-03	-	-	-	-	-	-	-	Update to Rel-10 version (MCC)	9.0.0	10.0.0	
2012-09	-	-	-	-	-	-	-	Updated to Rel-11 by MCC	10.0.0	11.0.0	