

# 3GPP TS 37.571-1 V10.5.0 (2013-09)

---

*Technical Specification*

**3rd Generation Partnership Project;  
Technical Specification Group Radio Access Network;  
Universal Terrestrial Radio Access (UTRA) and Evolved UTRA  
(E-UTRA) and Evolved Packet Core (EPC);  
User Equipment (UE) conformance specification for UE  
positioning;  
Part 1: Conformance test specification  
(Release 10)**

---



Keywords

---

UMTS, radio

**3GPP**

Postal address

---

3GPP support office address

---

650 Route des Lucioles - Sophia Antipolis  
Valbonne - FRANCE  
Tel.: +33 4 92 94 42 00 Fax: +33 4 93 65 47 16

Internet

---

<http://www.3gpp.org>

---

**Copyright Notification**

---

No part may be reproduced except as authorized by written permission.  
The copyright and the foregoing restriction extend to reproduction in all media.

© 2013, 3GPP Organizational Partners (ARIB, ATIS, CCSA, ETSI, TTA, TTC).  
All rights reserved.

UMTS™ is a Trade Mark of ETSI registered for the benefit of its members  
3GPP™ is a Trade Mark of ETSI registered for the benefit of its Members and of the 3GPP Organizational Partners  
LTE™ is a Trade Mark of ETSI currently being registered for the benefit of its Members and of the 3GPP Organizational Partners  
GSM® and the GSM logo are registered and owned by the GSM Association

# Contents

Foreword .....	10
Introduction .....	10
1 Scope .....	11
2 References.....	11
3 Definitions, symbols and abbreviations .....	13
3.1 Definitions .....	13
3.2 Symbols.....	13
3.3 Abbreviations.....	13
4 General test conditions .....	14
4.1 Introduction .....	14
4.2 GNSS test conditions .....	15
4.2.1 GNSS signals .....	15
4.2.2 GNSS frequency.....	15
4.2.3 GNSS static propagation conditions .....	15
4.2.4 GNSS multi-path conditions .....	15
4.2.5 UEs supporting multiple satellite signals .....	16
4.2.6 GNSS multi System Time Offsets .....	16
4.3 UTRA test conditions .....	16
4.3.1 UTRA frequency band and frequency range.....	16
4.3.2 UTRA frequency.....	17
4.3.3 Sensors.....	17
4.4 E-UTRA test conditions .....	17
4.4.1 E-UTRA frequency band and frequency range.....	17
4.4.2 Sensors.....	17
4.5 A-GNSS test conditions .....	17
4.5.1 General.....	17
4.5.2 UTRAN measurement parameters .....	17
4.5.2.1 UE based A-GNSS measurement parameters .....	17
4.5.2.2 UE assisted A-GNSS measurement parameters .....	17
4.5.2.3 2D position error .....	17
4.5.2.4 Response time .....	18
4.5.3 E-UTRAN measurement parameters .....	18
4.5.3.1 UE based A-GNSS measurement parameters .....	18
4.5.3.2 UE assisted A-GNSS measurement parameters .....	18
4.5.3.3 2D Error definition .....	18
4.5.3.4 Response time .....	18
4.5.4 Converting A-GNSS UE-assisted measurement reports into position estimates .....	18
4.6 ECID test conditions .....	19
4.6.1 Simulated cells.....	19
4.6.2 Propagation conditions.....	19
4.6.2.1 Static.....	19
4.6.2.2 Multi-path fading .....	19
4.6.3 UE Rx - Tx time difference reporting range.....	19
4.7 OTDOA test conditions .....	19
4.7.1 Simulated cells.....	19
4.7.2 Propagation conditions.....	20
4.7.2.1 Static.....	20
4.7.2.2 Multi-path fading .....	20
4.7.3 Response time .....	20
4.7.4 RSTD reporting range .....	20
5 UTRA A-GPS Minimum Performance requirements .....	22
5.1 General .....	22
5.2 Sensitivity .....	22

5.2.1	Sensitivity Coarse Time Assistance.....	22
5.2.1.1	Definition and applicability.....	22
5.2.1.2	Minimum requirements.....	22
5.2.1.3	Test purpose.....	22
5.2.1.4	Method of test.....	23
5.2.1.4.1	Initial conditions .....	23
5.2.1.4.2	Procedure.....	23
5.2.1.5	Test Requirements .....	23
5.2.2	Sensitivity Fine Time Assistance.....	24
5.2.2.1	Definition and applicability.....	24
5.2.2.2	Minimum requirements.....	24
5.2.2.3	Test purpose.....	25
5.2.2.4	Method of test.....	25
5.2.2.4.1	Initial conditions .....	25
5.2.2.4.2	Procedure.....	25
5.2.2.5	Test Requirements .....	25
5.3	Nominal Accuracy.....	26
5.3.1	Definition and applicability .....	26
5.3.2	Minimum requirements .....	26
5.3.3	Test purpose.....	26
5.3.4	Method of test.....	27
5.3.4.1	Initial conditions .....	27
5.3.4.2	Procedure.....	27
5.3.5	Test Requirements.....	28
5.4	Dynamic Range.....	28
5.4.1	Definition and applicability .....	28
5.4.2	Minimum requirements .....	28
5.4.3	Test purpose.....	29
5.4.4	Method of test.....	29
5.4.4.1	Initial conditions .....	29
5.4.4.2	Procedure.....	29
5.4.5	Test Requirements.....	30
5.5	Multi-path Performance .....	30
5.5.1	Definition and applicability .....	30
5.5.2	Minimum requirements .....	30
5.5.3	Test purpose.....	31
5.5.4	Method of test.....	31
5.5.4.1	Initial conditions .....	31
5.5.4.2	Procedure.....	31
5.5.5	Test Requirements.....	32
5.6	Moving Scenario and Periodic Update Performance .....	32
5.6.1	Definition and applicability .....	32
5.6.2	Minimum requirements .....	32
5.6.3	Test purpose.....	33
5.6.4	Method of test.....	33
5.6.4.1	Initial conditions .....	33
5.6.4.2	Procedure.....	34
5.6.5	Test Requirements.....	35
6	UTRA A-GNSS Minimum Performance requirements.....	36
6.1	General .....	36
6.2	Sensitivity .....	36
6.2.1	Sensitivity Coarse Time Assistance.....	36
6.2.1.1	Definition and applicability.....	36
6.2.1.2	Minimum requirements.....	36
6.2.1.3	Test purpose.....	37
6.2.1.4	Method of test.....	37
6.2.1.4.1	Initial conditions .....	37
6.2.1.4.2	Procedure.....	37
6.2.1.5	Test Requirements .....	38
6.2.2	Sensitivity Fine Time Assistance.....	39
6.2.2.1	Definition and applicability.....	39

6.2.2.2	Minimum requirements.....	39
6.2.2.3	Test purpose.....	40
6.2.2.4	Method of test.....	40
6.2.2.4.1	Initial conditions .....	40
6.2.2.4.2	Procedure.....	40
6.2.2.5	Test Requirements .....	41
6.3	Nominal Accuracy.....	41
6.3.1	Definition and applicability .....	41
6.3.2	Minimum requirements .....	42
6.3.3	Test purpose.....	42
6.3.4	Method of test.....	43
6.3.4.1	Initial conditions .....	43
6.3.4.2	Procedure.....	43
6.3.5	Test Requirements.....	44
6.4	Dynamic Range.....	44
6.4.1	Definition and applicability .....	44
6.4.2	Minimum requirements .....	45
6.4.3	Test purpose.....	45
6.4.4	Method of test.....	46
6.4.4.1	Initial conditions .....	46
6.4.4.2	Procedure.....	46
6.4.5	Test Requirements.....	46
6.5	Multi-path Performance .....	47
6.5.1	Definition and applicability .....	47
6.5.2	Minimum requirements .....	48
6.5.3	Test purpose.....	48
6.5.4	Method of test.....	48
6.5.4.1	Initial conditions .....	48
6.5.4.2	Procedure.....	49
6.5.5	Test Requirements.....	49
6.6	Moving Scenario and Periodic Update Performance .....	50
6.6.1	Definition and applicability .....	50
6.6.2	Minimum requirements .....	51
6.6.3	Test purpose.....	51
6.6.4	Method of test.....	52
6.6.4.1	Initial conditions .....	52
6.6.4.2	Procedure.....	52
6.6.5	Test Requirements.....	53
7	E-UTRA A-GNSS minimum performance requirements .....	55
7.1	Sensitivity .....	55
7.1.1	Sensitivity Coarse time assistance.....	55
7.1.1.1	Sub-tests .....	55
7.1.1.2	Test purpose.....	55
7.1.1.3	Test applicability.....	55
7.1.1.4	Minimum conformance requirements .....	55
7.1.1.5	Test description .....	56
7.1.1.5.1	Initial conditions .....	56
7.1.1.5.2	Test procedure .....	57
7.1.1.5.3	Message contents .....	57
7.1.1.6	Test requirement .....	58
7.1.2	Sensitivity Fine time assistance.....	59
7.1.2.1	Sub-tests .....	59
7.1.2.2	Test purpose.....	60
7.1.2.3	Test applicability.....	60
7.1.2.4	Minimum conformance requirements .....	60
7.1.2.5	Test description .....	61
7.1.2.5.1	Initial conditions .....	61
7.1.2.5.2	Test procedure .....	61
7.1.2.5.3	Message contents .....	62
7.1.2.6	Test requirement .....	63
7.2	Nominal Accuracy.....	63

7.2.1	Sub-tests .....	63
7.2.2	Test purpose.....	64
7.2.3	Test applicability.....	64
7.2.4	Minimum conformance requirements .....	64
7.2.5	Test description .....	65
7.2.5.1	Initial conditions .....	65
7.2.5.2	Test procedure .....	65
7.2.5.3	Message contents .....	66
7.2.6	Test requirement .....	67
7.3	Dynamic Range.....	68
7.3.1	Sub-tests .....	68
7.3.2	Test purpose.....	69
7.3.3	Test applicability.....	69
7.3.4	Minimum conformance requirements .....	69
7.3.5	Test description .....	70
7.3.5.1	Initial conditions .....	70
7.3.5.2	Test procedure .....	70
7.3.5.3	Message contents .....	71
7.3.6	Test requirement .....	72
7.4	Multi-Path scenario .....	73
7.4.1	Sub-tests .....	73
7.4.2	Test purpose.....	73
7.4.3	Test applicability.....	74
7.4.4	Minimum conformance requirements .....	74
7.4.5	Test description .....	75
7.4.5.1	Initial conditions .....	75
7.4.5.2	Test procedure .....	75
7.4.5.3	Message contents .....	76
7.4.6	Test requirement .....	77
7.5	Moving scenario and periodic update .....	77
7.5.1	Sub-tests .....	77
7.5.2	Test purpose.....	78
7.5.3	Test applicability.....	78
7.5.4	Minimum conformance requirements .....	78
7.5.5	Test description .....	79
7.5.5.1	Initial conditions .....	79
7.5.5.2	Test procedure .....	80
7.5.5.3	Message contents .....	81
7.5.6	Test requirement .....	81
8	E-UTRA ECID measurement requirements.....	82
8.1	UE Rx – Tx Time Difference .....	82
8.1.1	E-UTRAN FDD UE Rx – Tx time difference case.....	82
8.1.1.1	Test purpose.....	82
8.1.1.2	Test applicability.....	83
8.1.1.3	Minimum conformance requirements .....	83
8.1.1.4	Test description .....	83
8.1.1.4.1	Initial conditions .....	83
8.1.1.4.2	Test procedure .....	84
8.1.1.4.3	Message contents .....	84
8.1.1.5	Test requirement .....	87
8.1.2	E-UTRAN TDD UE Rx – Tx time difference case.....	89
8.1.2.1	Test purpose.....	89
8.1.2.2	Test applicability.....	89
8.1.2.3	Minimum conformance requirements .....	89
8.1.2.4	Test description .....	89
8.1.2.4.1	Initial conditions .....	89
8.1.2.4.2	Test procedure .....	90
8.1.2.4.3	Message contents .....	90
8.1.2.5	Test requirement .....	93

9	E-UTRA OTDOA measurement requirements .....	95
9.1	RSTD Intra-Frequency Measurements .....	95
9.1.1	FDD RSTD Measurement Reporting Delay .....	95
9.1.1.1	Test purpose.....	95
9.1.1.2	Test applicability.....	95
9.1.1.3	Minimum conformance requirements .....	95
9.1.1.4	Test description .....	96
9.1.1.4.1	Initial conditions .....	96
9.1.1.4.2	Test procedure.....	98
9.1.1.4.3	Message contents .....	99
9.1.1.5	Test requirement .....	103
9.1.2	TDD RSTD Measurement Reporting Delay .....	106
9.1.2.1	Test purpose.....	106
9.1.2.2	Test applicability.....	106
9.1.2.3	Minimum conformance requirements .....	106
9.1.2.4	Test description .....	107
9.1.2.4.1	Initial conditions .....	107
9.1.2.4.2	Test procedure.....	109
9.1.2.4.3	Message contents .....	110
9.1.2.5	Test requirement .....	113
9.1.3	FDD RSTD Measurement Accuracy .....	116
9.1.3.1	Test purpose.....	116
9.1.3.2	Test applicability.....	116
9.1.3.3	Minimum conformance requirements .....	116
9.1.3.4	Test description .....	117
9.1.3.4.1	Initial conditions .....	117
9.1.3.4.2	Test procedure.....	120
9.1.3.4.3	Message contents .....	120
9.1.3.5	Test requirement .....	123
9.1.4	TDD RSTD Measurement Accuracy .....	124
9.1.4.1	Test purpose.....	125
9.1.4.2	Test applicability.....	125
9.1.4.3	Minimum conformance requirements .....	125
9.1.4.4	Test description .....	125
9.1.4.4.1	Initial conditions .....	125
9.1.4.4.2	Test procedure.....	127
9.1.4.4.3	Message contents .....	128
9.1.4.5	Test requirement .....	130
9.2	RSTD Inter-Frequency Measurements .....	131
9.2.1	FDD-FDD inter-frequency RSTD measurement reporting delay .....	131
9.2.1.1	Test purpose.....	132
9.2.1.2	Test applicability.....	132
9.2.1.3	Minimum conformance requirements .....	132
9.2.1.4	Test description .....	133
9.2.1.4.1	Initial conditions .....	133
9.2.1.4.2	Test procedure.....	135
9.2.1.4.3	Message contents .....	136
9.2.1.5	Test requirement .....	140
9.2.2	TDD-TDD inter-frequency RSTD measurement reporting delay .....	143
9.2.2.1	Test purpose.....	143
9.2.2.2	Test applicability.....	143
9.2.2.3	Minimum conformance requirements .....	143
9.2.2.4	Test description .....	144
9.2.2.4.1	Initial conditions .....	144
9.2.2.4.2	Test procedure.....	146
9.2.2.4.3	Message contents .....	147
9.2.2.5	Test requirement .....	151
9.2.3	Void .....	154
9.2.4	FDD-FDD inter frequency RSTD Accuracy .....	154
9.2.4.1	Test purpose.....	154
9.2.4.2	Test applicability.....	154
9.2.4.3	Minimum conformance requirements .....	154

9.2.4.4	Test description .....	155
9.2.4.4.1	Initial conditions .....	155
9.2.4.4.2	Test procedure.....	158
9.2.4.4.3	Message contents.....	158
9.2.4.5	Test requirement .....	161
9.2.5	TDD-TDD inter frequency RSTD Accuracy .....	162
9.2.5.1	Test purpose.....	163
9.2.5.2	Test applicability.....	163
9.2.5.3	Minimum conformance requirements .....	163
9.2.5.4	Test description .....	163
9.2.5.5	Test requirement .....	168
10.1	FDD RSTD Measurement Reporting Delay for Carrier Aggregation.....	170
10.1.1	Test purpose.....	170
10.1.2	Test applicability .....	170
10.1.3	Minimum conformance requirements.....	170
10.1.3.1	Measurements on the secondary component carrier .....	170
10.1.3.2	Measurements on both primary component carrier and secondary component carrier .....	170
10.1.4	Test description .....	171
10.1.4.1	Initial conditions .....	171
10.1.4.2	Test procedure.....	173
10.1.4.3	Message contents .....	175
10.1.5	Test requirement.....	178
10.2	TDD RSTD Measurement Reporting Delay for Carrier Aggregation .....	181
10.2.1	Test purpose.....	181
10.2.2	Test applicability .....	181
10.2.3	Minimum conformance requirements.....	181
10.2.3.1	Measurements on the secondary component carrier .....	181
10.2.3.2	Measurements on both primary component carrier and secondary component carrier .....	181
10.2.4	Test description .....	182
10.2.4.1	Initial conditions .....	182
10.2.4.2	Test procedure.....	184
10.2.4.3	Message contents .....	186
10.2.5	Test requirement.....	189
10.3	FDD RSTD Measurement Accuracy for Carrier Aggregation .....	192
10.3.1	Test purpose.....	192
10.3.2	Test applicability .....	192
10.3.3	Minimum conformance requirements.....	192
10.3.4	Test description .....	192
10.3.4.1	Initial conditions .....	192
10.3.4.2	Test procedure.....	194
10.3.4.3	Message contents .....	195
10.3.5	Test requirement.....	198
10.4	TDD RSTD Measurement Accuracy for Carrier Aggregation.....	199
10.4.1	Test purpose.....	199
10.4.2	Test applicability .....	200
10.4.3	Minimum conformance requirements.....	200
10.4.4	Test description .....	200
10.4.4.1	Initial conditions .....	200
10.4.4.2	Test procedure.....	202
10.4.4.3	Message contents .....	202
10.4.5	Test requirement.....	205
Annex A (informative):	Connection Diagrams.....	206
Annex B (normative):	Converting A-GNSS UE-assisted measurement reports into position estimates .....	211
B.1	Introduction .....	211
B.2	UTRAN UE measurement reports for A-GPS L1 C/A only .....	211
B.3	UTRAN UE measurement reports for A-GNSS .....	211
B.4	E-UTRAN UE measurement reports.....	213
B.5	WLS position solution .....	213



Annex C (normative):	General test conditions and declarations .....	216
C.1	Acceptable uncertainty of Test System .....	216
C.1.1	Measurement of test environments .....	216
C.1.2	A-GNSS Minimum Performance requirements .....	217
C.1.3	ECID and OTDOA Measurement requirements .....	218
C.2	Test Parameter Relaxations (This clause is informative) .....	219
C.2.1	A-GNSS Minimum Performance requirements .....	220
C.2.2	ECID and OTDOA Measurement requirements .....	221
C.3	Interpretation of measurement results .....	221
C.4	Derivation of Test Requirements (This clause is informative) .....	222
Annex D (normative):	Rules for statistical testing .....	227
D.1	Test Method .....	227
D.2	Error Ratio (ER) .....	227
D.3	Test Design .....	227
D.3.1	Confidence level .....	227
D.3.2	Introduction: Supplier Risk versus Customer Risk .....	227
D.3.3	Supplier Risk versus Customer Risk .....	228
D.3.4	Introduction: Standard test versus early decision concept .....	228
D.3.5	Standard test versus early decision concept .....	229
D.3.6	Selectivity .....	229
D.3.7	Design of the test .....	230
D.4	Pass fail decisions .....	232
D.4.1	Numerical definition of the pass fail limits for A-GNSS test cases .....	232
D.4.2	Pass fail decision rules for A-GNSS test cases .....	232
D.4.3	Numerical definition of the pass fail limits for ECID and OTDOA test cases .....	233
D.4.4	Pass fail decision rules for ECID and OTDOA test cases .....	234
D.4.5	Background information to the pass fail limits .....	234
Annex E (normative):	Conditions for ECID and OTDOA requirements applicability for operating bands .....	236
E.1	Conditions for E-CID Measurements .....	236
E.2	Conditions for OTDOA intra-frequency RSTD Measurements .....	236
E.3	Conditions for OTDOA inter-frequency RSTD Measurements .....	237
Annex F (normative):	UTRAN Generic procedures .....	238
F.1	General .....	238
F.2	UTRAN connection set up .....	238
F.2.1	Initial conditions .....	238
F.2.2	Procedures .....	238
F.2.3	Specific message contents .....	239
F.3	UTRAN connection release .....	239
F.3.1	Procedure .....	239
F.3.2	Specific message contents .....	239
Annex G (normative):	Environmental conditions .....	240
G.1	General .....	240
G.2	Environmental requirements .....	240
G.2.1	Temperature .....	240
G.2.2	Voltage .....	240
Annex H (informative):	Change history .....	241

---

## Foreword

This Technical Specification has been produced by the 3<sup>rd</sup> Generation Partnership Project (3GPP).

The contents of the present document are subject to continuing work within the TSG and may change following formal TSG approval. Should the TSG modify the contents of the present document, it will be re-released by the TSG with an identifying change of release date and an increase in version number as follows:

Version x.y.z

where:

- x the first digit:
  - 1 presented to TSG for information;
  - 2 presented to TSG for approval;
  - 3 or greater indicates TSG approved document under change control.
- y the second digit is incremented for all changes of substance, i.e. technical enhancements, corrections, updates, etc.
- z the third digit is incremented when editorial only changes have been incorporated in the document.

---

## Introduction

The present document is part 1 of a multi-parts TS:

**3GPP TS 37.571-1: Universal Terrestrial Radio Access (UTRA) and Evolved UTRA (E-UTRA) and Evolved Packet Core (EPC); User Equipment (UE) conformance specification for UE positioning; Part 1: Conformance test specification.**

3GPP TS 37.571-2: Universal Terrestrial Radio Access (UTRA) and Evolved UTRA (E-UTRA) and Evolved Packet Core (EPC); User Equipment (UE) conformance specification for UE positioning; Part 2: Protocol conformance.

3GPP TS 37.571-3: Universal Terrestrial Radio Access (UTRA) and Evolved UTRA (E-UTRA) and Evolved Packet Core (EPC); User Equipment (UE) conformance specification for UE positioning; Part 3: Implementation Conformance Statement (ICS).

3GPP TS 37.571-4: Universal Terrestrial Radio Access (UTRA) and Evolved UTRA (E-UTRA) and Evolved Packet Core (EPC); User Equipment (UE) conformance specification for UE positioning; Part 4: Test suites.

3GPP TS 37.571-5: Universal Terrestrial Radio Access (UTRA) and Evolved UTRA (E-UTRA) and Evolved Packet Core (EPC); User Equipment (UE) conformance specification for UE positioning; Part 5: Test scenarios and assistance data.

---

# 1 Scope

The present document specifies the procedures for the conformance test of the measurement requirements for FDD mode of UTRA and FDD or TDD mode of E-UTRA for the User Equipment (UE) that supports one or more of the defined positioning methods. These positioning methods are for UTRA: Assisted Global Positioning System (A-GPS), Assisted Global Navigation Satellite Systems (A-GNSS) and for E-UTRA: Assisted Global Navigation Satellite System (A-GNSS), Observed Time Difference of Arrival (OTDOA), Enhanced Cell ID (ECID).

Tests are only applicable to those mobiles that are intended to support the appropriate functionality. To indicate the circumstances in which tests apply, this is noted in the "Test applicability" part of the test.

The Implementation Conformance Statement (ICS) pro-forma could be found in the 3<sup>rd</sup> part of the present document.

---

# 2 References

The following documents contain provisions which, through reference in this text, constitute provisions of the present document.

- References are either specific (identified by date of publication, edition number, version number, etc.) or non-specific.
- For a specific reference, subsequent revisions do not apply.
- For a non-specific reference, the latest version applies. In the case of a reference to a 3GPP document (including a GSM document), a non-specific reference implicitly refers to the latest version of that document *in the same Release as the present document*.

- [1] 3GPP TR 21.905: "Vocabulary for 3GPP Specifications".
- [2] 3GPP TS 36.101: "Evolved Universal Terrestrial Radio Access (E-UTRA); User Equipment (UE) radio transmission and reception".
- [3] 3GPP TS 36.171: "Evolved Universal Terrestrial Radio Access (E-UTRA); Requirements for Support of Assisted Global Navigation Satellite System (A-GNSS)".
- [4] 3GPP TS 36.355: "Evolved Universal Terrestrial Radio Access (E-UTRA); LTE Positioning Protocol (LPP)".
- [5] 3GPP TS 36.302: "Evolved Universal Terrestrial Radio Access (E-UTRA); Services provided by the physical layer".
- [6] 3GPP TS 36.214: "Evolved Universal Terrestrial Radio Access (E-UTRA); Physical layer; Measurements".
- [7] ETSI TR 102 273-1-2: "Electromagnetic compatibility and Radio spectrum Matters (ERM); Improvement on Radiated Methods of Measurement (using test site) and evaluation of the corresponding measurement uncertainties; Part 1: Uncertainties in the measurement of mobile radio equipment characteristics; Sub-part 2: Examples and annexes".
- [8] IS-GPS-200, Revision D, Navstar GPS Space Segment/Navigation User Interfaces, March 7<sup>th</sup>, 2006.
- [9] P. Axelrad, R.G. Brown, "GPS Navigation Algorithms", in Chapter 9 of "Global Positioning System: Theory and Applications", Volume 1, B.W. Parkinson, J.J. Spilker (Ed.), A.M. Inst. of Aeronautics and Astronautics Inc., 1996.
- [10] S.K. Gupta, "Test and Evaluation Procedures for the GPS User Equipment", ION-GPS Red Book, Volume 1, p. 119.
- [11] 3GPP TS 36.509: "Evolved Universal Terrestrial Radio Access (E-UTRA) and Evolved Packet Core (EPC); Special conformance testing functions for User Equipment (UE)".

- [12] IS-GPS-705, Navstar GPS Space Segment/User Segment L5 Interfaces, September 22, 2005.
- [13] IS-GPS-800, Navstar GPS Space Segment/User Segment L1C Interfaces, September 4, 2008.
- [14] IS-QZSS, Quasi Zenith Satellite System Navigation Service Interface Specifications for QZSS, Ver.1.1, July 31, 2009.
- [15] Galileo OS Signal in Space ICD (OS SIS ICD), Draft 0, Galileo Joint Undertaking, May 23<sup>rd</sup>, 2006.
- [16] Global Navigation Satellite System GLONASS Interface Control Document, Version 5.1, 2008.
- [17] Specification for the Wide Area Augmentation System (WAAS), US Department of Transportation, Federal Aviation Administration, DTFA01-96-C-00025, 2001.
- [18] 3GPP TS 36.508: "Evolved Universal Terrestrial Radio Access (E-UTRA) and Evolved Packet Core (EPC); Common test environments for User Equipment (UE) conformance testing".
- [19] 3GPP TS 25.172: "Requirements for support of Assisted Galileo and Additional Navigation Satellite Systems (A-GANSS); Frequency Division Duplex (FDD)".
- [20] 3GPP TS 37.571-5: "Universal Terrestrial Radio Access (UTRA) and Evolved UTRA (E-UTRA) and Evolved Packet Core (EPC); User Equipment (UE) conformance specification for UE positioning; Part 5: Test scenarios and assistance data
- [21] 3GPP TS 36.104: "Evolved Universal Terrestrial Radio Access (E-UTRA); Base Station (BS) radio transmission and reception".
- [22] 3GPP TS 36.331: "Evolved Universal Terrestrial Radio Access (E-UTRA); Radio Resource Control (RRC); Protocol specification".
- [23] 3GPP TS 36.133: "Evolved Universal Terrestrial Radio Access (E-UTRA); Requirements for support of radio resource management".
- [24] 3GPP TS 36.521-1: "Evolved Universal Terrestrial Radio Access (E-UTRA); User Equipment (UE) conformance specification Radio transmission and reception Part 1: Conformance Testing".
- [25] 3GPP TS 36.521-3: "Evolved Universal Terrestrial Radio Access (E-UTRA); User Equipment (UE) conformance specification; Radio transmission and reception; Part 3: Radio Resource Management (RRM) conformance testing".
- [26] 3GPP TS 36.211: "Evolved Universal Terrestrial Radio Access (E-UTRA); Physical Channels and Modulation".
- [27] 3GPP TR 25.990: "Vocabulary for UTRAN".
- [28] 3GPP TS 34.108: "Common test environments for User Equipment (UE) conformance testing".
- [29] 3GPP TS 34.109: "Terminal logical test interface; Special conformance testing functions".
- [30] 3GPP TS 25.331: "Radio Resource Control (RRC) protocol specification".
- [31] 3GPP TS 25.171: "Requirements for support of Assisted Global Positioning System (A-GPS); Frequency Division Duplex (FDD)".
- [32] 3GPP TS 25.302: "Services provided by the physical layer".
- [33] 3GPP TS 25.215: "Physical layer; Measurements (FDD)".
- [34] 3GPP TS 36.321: "Medium Access Control (MAC) protocol specification".

## 3 Definitions, symbols and abbreviations

### 3.1 Definitions

For the purposes of the present document, the terms and definitions given in TR 21.905 [1], 3GPP TR 25.990 [27], TS 36.101 [2], 3GPP TS 36.104 [21] and the following apply. A term defined in the present document takes precedence over the definition of the same term, if any, in TR 21.905 [1].

**Horizontal Dilution Of Precision (HDOP):** measure of position determination accuracy that is a function of the geometrical layout of the satellites used for the fix, relative to the receiver antenna

### 3.2 Symbols

For the purposes of the present document, the abbreviations given in TR 21.905 [1], 3GPP TR 25.990 [27] and the following apply. An abbreviation defined in the present document takes precedence over the definition of the same abbreviation, if any, in TR 21.905 [1].

E1	Galileo E1 navigation signal with carrier frequency of 1575.420 MHz.
E5	Galileo E5 navigation signal with carrier frequency of 1191.795 MHz.
E6	Galileo E6 navigation signal with carrier frequency of 1278.750 MHz.
G1	GLONASS navigation signal in the L1 sub-bands with carrier frequencies $1602 \text{ MHz} \pm k \times 562.5 \text{ kHz}$ .
G2	GLONASS navigation signal in the L2 sub-bands with carrier frequencies $1246 \text{ MHz} \pm k \times 437.5 \text{ kHz}$ .
k	GLONASS channel number, $k = -7 \dots 13$ .
L1 C/A	GPS or QZSS L1 navigation signal carrying the Coarse/Acquisition code with carrier frequency of 1575.420 MHz.
L1C	GPS or QZSS L1 Civil navigation signal with carrier frequency of 1575.420 MHz.
L2C	GPS or QZSS L2 Civil navigation signal with carrier frequency of 1227.600 MHz.
L5	GPS or QZSS L5 navigation signal with carrier frequency of 1176.450 MHz.
PRP	Received (linear) average power of the resource elements that carry E-UTRA PRS, measured at the UE antenna connector.
<b>G</b>	Geometry Matrix.
$\rho_{GNSS_m,i}$	Measured pseudo-range of satellite $i$ of GNSS <sub>m</sub> .
<b>W</b>	Weighting Matrix.
$\mathbf{1}_{GNSS_m,i}$	Line of sight unit vector from the user to the satellite $i$ of GNSS <sub>m</sub> .
<b>x</b>	State vector of user position and clock bias.
$T_s$	Basic time unit, defined in TS 36.211 [26], clause 4.
$\hat{E}_s$	Received energy per RE (power normalized to the subcarrier spacing) during the useful part of the symbol, i.e. excluding the cyclic prefix, at the UE antenna connector.
$I_o$	The total received power density, including signal and interference, as measured at the UE antenna connector.
$I_{ot}$	The received power spectral density of the total noise and interference for a certain RE (power integrated over the RE and normalized to the subcarrier spacing) as measured at the UE antenna connector.
$N_{oc}$	The power spectral density of a white noise source (average power per RE normalised to the subcarrier spacing), simulating interference from cells that are not defined in a test procedure, as measured at the UE antenna connector.
$\text{PRS} \hat{E}_s / I_{ot}$	The ratio of the average received energy per PRS RE during the useful part of the symbol to the average received power spectral density of the total noise and interference for this RE, where the ratio is measured over all REs which carry PRS.

### 3.3 Abbreviations

For the purposes of the present document, the following abbreviations apply:

A-GNSS	Assisted Global Navigation Satellite System
A-GPS	Assisted - Global Positioning System
AWGN	Additive White Gaussian Noise
C/A	Coarse/Acquisition
DRX	Discontinuous Reception
DUT	Device Under Test
ECEF	Earth Centred, Earth Fixed
EPRE	Energy Per Resource Element
E-UTRA	Evolved UMTS Terrestrial Radio Access
E-UTRAN	Evolved UMTS Terrestrial Radio Access Network
FDD	Frequency Division Duplex
GLONASS	GLObal'naya NAVigatsionnaya Sputnikovaya Sistema (English: Global Navigation Satellite System)
GNSS	Global Navigation Satellite System
GPS	Global Positioning System
GSS	GNSS System Simulator
HDOP	Horizontal Dilution Of Precision
ICD	Interface Control Document
IS	Interface Specification
LOS	Line Of Sight
LPP	LTE Positioning Protocol
OCNG	OFDMA Channel Noise Generator
OCNS	Orthogonal Channel Noise Simulator
OTDOA	Observed Time Difference Of Arrival
PBCH	Physical Broadcast Channel
PCC	Primary Component Carrier
PCell	Primary Cell
PCFICH	Physical Control Format Indicator Channel
PDCCH	Physical Downlink Control Channel
PDSCH	Physical Downlink Shared Channel
PHICH	Physical Hybrid ARQ Indicator Channel
PPM	Parts per million
PRS	Positioning Reference Signal
PSS	Primary Synchronization Signal
QZSS	Quasi-Zenith Satellite System
RB	Resource Block
RE	Resource Element
RRC	Radio Resource Control
RSTD	Reference Signal Time Difference
SBAS	Space Based Augmentation System
SCC	Secondary Component Carrier
SCell	Secondary Cell
SS	System simulator
SSS	Secondary Synchronization Signal
SV	Space Vehicle
SV ID	Space Vehicle Identity
TDD	Time Division Duplex
TTF	Time To First Fix
UE	User Equipment
WLS	Weighted Least Square
WGS-84	World Geodetic System 1984

---

## 4 General test conditions

### 4.1 Introduction

This clause defines the various common test conditions required for the various measurement requirements in the remainder of the document.

In this clause the terms GNSS and A-GNSS also include the cases where the only satellite system used is GPS unless otherwise stated.

## 4.2 GNSS test conditions

### 4.2.1 GNSS signals

The GNSS signal is defined at the A-GNSS antenna connector of the UE. For UE with integral antenna only, a reference antenna with a gain of 0 dBi is assumed.

### 4.2.2 GNSS frequency

The GNSS signals shall be transmitted with a frequency accuracy of  $\pm 0.025$  PPM.

### 4.2.3 GNSS static propagation conditions

The propagation for the static performance measurement is an Additive White Gaussian Noise (AWGN) environment. No fading and multi-paths exist for this propagation model.

### 4.2.4 GNSS multi-path conditions

Doppler frequency difference between direct and reflected signal paths is applied to the carrier and code frequencies. The Carrier and Code Doppler frequencies of LOS and multi-path for GNSS signals are defined in table 4.2.1.

**Table 4.2.1: Multi-path Conditions for GNSS Signals**

Initial relative Delay [GNSS chip]	Carrier Doppler frequency of tap [Hz]	Code Doppler frequency of tap [Hz]	Relative mean Power [dB]
0	$F_d$	$F_d / N$	0
X	$F_d - 0.1$	$(F_d - 0.1) / N$	Y
NOTE: Discrete Doppler frequency is used for each tap.			

Where the X and Y depends on the GNSS signal type and is shown in Table 4.2.2, and N is the ratio between the transmitted carrier frequency of the signals and the transmitted chip rate as shown in Table 4.2.3 (where k in Table 4.2.3 is the GLONASS frequency channel number).

**Table 4.2.2**

System	Signals	X [m]	Y [dB]
Galileo	E1	125	-4.5
	E5a	15	-6
	E5b	15	-6
GPS/Modernized GPS	L1 C/A	0.5 chip / 150m	-6
	L1C	125	-4.5
	L2C	150	-6
	L5	15	-6
GLONASS	G1	275	-12.5
	G2	275	-12.5

Table 4.2.3

System	Signals	N
Galileo	E1	1540
	E5a	115
	E5b	118
GPS/Modernized GPS	L1 C/A	1540
	L1C	1540
	L2C	1200
	L5	115
GLONASS	G1	$3135.03 + k \cdot 1.10$
	G2	$2438.36 + k \cdot 0.86$

The initial carrier phase difference between taps shall be randomly selected between 0 and  $2\pi$  radians. The initial value shall have uniform random distribution.

## 4.2.5 UEs supporting multiple satellite signals

For UEs supporting multiple satellite signals, different minimum performance requirements may be associated with different signals. The satellite simulator shall generate all signals supported by the UE. Signals not supported by the UE do not need to be simulated. The relative power levels of each signal type for each GNSS are defined in Table 4.2.4. The individual test scenarios in clauses 6 and 7 define the reference signal power level for each satellite. The power level of each simulated satellite signal type shall be set to the reference signal power level defined in each test scenario in clauses 6 and 7 plus the relative power level defined in Table 4.2.4.

Table 4.2.4: Relative signal power levels for each signal type for each GNSS

	Galileo		GPS/Modernized GPS		GLONASS		QZSS		SBAS	
	Signal	Power	Signal	Power	Signal	Power	Signal	Power	Signal	Power
Signal power levels relative to reference power levels	E1	0 dB	L1 C/A	0 dB	G1	0 dB	L1 C/A	0 dB	L1	0 dB
	E6	+2 dB	L1C	+1.5 dB	G2	-6 dB	L1C	+1.5 dB		
	E5	+2 dB	L2C	-1.5 dB			L2C	-1.5 dB		
			L5	+3.6 dB			L5	+3.6 dB		

NOTE 1: For test cases which involve “Modernized GPS”, the satellite simulator shall also generate the GPS L1 C/A signal if the UE supports “GPS” in addition to “Modernized GPS”.

NOTE 2: The signal power levels in the Test Parameter Tables represent the total signal power of the satellite per channel not e.g. pilot and data channels separately.

## 4.2.6 GNSS multi System Time Offsets

If more than one GNSS is used in a test, the accuracy of the GNSS-GNSS Time Offsets used at the system simulator shall be better than 3 ns.

## 4.3 UTRA test conditions

### 4.3.1 UTRA frequency band and frequency range

The UTRA tests in clauses 5 and 6 in the present document are performed at mid range of the UTRA operating frequency band of the UE. The UARFCNs to be used for mid range are defined in 3GPP TS 34.108 [28], clause 5.1.1.

If the UE supports multiple frequency bands then the Sensitivity tests in clauses 5.2 and 6.2 shall be repeated in each supported frequency band.



## 4.3.2 UTRA frequency

For the UTRA tests in clause 5 the UTRA frequency shall be offset with respect to the nominal frequency by an amount equal to the sum of +0.025 PPM and the offset in PPM of the actual transmitted GPS carrier frequency with respect to the nominal GPS frequency.

## 4.3.3 Sensors

The UTRA tests in clause 6 shall be met without the use of any data coming from sensors that can aid the positioning. A dedicated test message 'RESET UE POSITIONING STORED INFORMATION' has been defined in TS 34.109 [29] for the purpose of disabling any such sensors.

## 4.4 E-UTRA test conditions

### 4.4.1 E-UTRA frequency band and frequency range

The E-UTRA A-GNSS tests in clause 7 are performed on the mid range EA RFCN of the E-UTRA operating frequency band of the UE as defined in TS 36.508 [18] clause 4.3.1.

If the UE supports multiple frequency bands then the A-GNSS Sensitivity tests in clause 7.1 shall be repeated in each supported frequency band.

### 4.4.2 Sensors

All the minimum performance requirements in clause 7 shall be met without the use of any data coming from sensors that can aid the positioning. A dedicated test message 'RESET UE POSITIONING STORED INFORMATION' has been defined in TS 36.509 [11] for the purpose of disabling any such sensors.

## 4.5 A-GNSS test conditions

### 4.5.1 General

Clauses 5, 6 and 7 define the minimum performance requirements for both UE based and UE assisted A-GNSS terminals. If a terminal supports both modes then it shall be tested in both modes.

### 4.5.2 UTRAN measurement parameters

#### 4.5.2.1 UE based A-GNSS measurement parameters

In case of UE-based A-GNSS, the measurement parameters are contained in the RRC UE POSITIONING POSITION ESTIMATE INFO IE. The measurement parameter is the horizontal position estimate reported by the UE and expressed in latitude/longitude.

#### 4.5.2.2 UE assisted A-GNSS measurement parameters

In case of UE-assisted A-GNSS, the measurement parameters are contained in the RRC UE POSITIONING GNSS MEASURED RESULTS IE and/or the RRC UE POSITIONING GPS MEASURED RESULTS IE. The measurement parameters are the UE GNSS Code Phase measurements and/or the UE GPS Code Phase measurements, as specified in 3GPP TS 25.302 [32] and 3GPP TS 25.215 [33]. The UE GNSS Code Phase measurements and/or the UE GPS Code Phase measurements are converted into a horizontal position estimate using the procedure detailed in Annex B.

#### 4.5.2.3 2D position error

The 2D position error is defined by the horizontal difference in meters between the ellipsoid point reported or calculated from the UE Measurement Report and the actual simulated position of the UE in the test case considered.

#### 4.5.2.4 Response time

Max Response Time is defined as the time starting from the moment that the UE has received the final RRC measurement control message containing reporting criteria different from "No Reporting" sent before the UE sends the measurement report containing the position estimate or the GNSS and/or GPS measured result, and ending when the UE starts sending the measurement report containing the position estimate or the GNSS and/or GPS measured result on the Uu interface. The response times specified for all test cases are Time-to-First-Fix (TTFF) unless otherwise stated, i.e. the UE shall not re-use any information on GNSS time, location or other aiding data that was previously acquired or calculated and stored internally in the UE. A dedicated test message 'RESET UE POSITIONING STORED INFORMATION' specified in 3GPP TS 34.109 [29], clause 5.4, has been defined for the purpose of deleting this information.

### 4.5.3 E-UTRAN measurement parameters

#### 4.5.3.1 UE based A-GNSS measurement parameters

In case of UE-based A-GNSS, the measurement parameters are contained in the LPP *GNSS-LocationInformation* IE which is included in the *A-GNSS-ProvideLocationInformation* IE provided in the LPP message of type PROVIDE LOCATION INFORMATION. The measurement parameter in case of UE-based A-GNSS is the horizontal position estimate reported by the UE and expressed in latitude/longitude.

#### 4.5.3.2 UE assisted A-GNSS measurement parameters

In case of UE-assisted A-GNSS, the measurement parameters are contained in the LPP *GNSS-SignalMeasurementInformation* IE which is included in the *A-GNSS-ProvideLocationInformation* IE provided in the LPP message of type PROVIDE LOCATION INFORMATION. The measurement parameters in case of UE-assisted A-GNSS are the UE GNSS code phase measurements, as specified in 3GPP TS 36.302 [5] and 3GPP TS 36.214 [6]. The UE GNSS code phase measurements are converted into a horizontal position estimate using the procedure detailed in Annex B.

#### 4.5.3.3 2D Error definition

The 2D position error is defined by the horizontal difference in meters between the ellipsoid point reported or calculated from the LPP message of type PROVIDE LOCATION INFORMATION and the actual position of the UE in the test case considered.

#### 4.5.3.4 Response time

Max Response Time is defined as the time starting from the moment that the UE has received the LPP message of type REQUEST LOCATION INFORMATION, and ending when the UE starts sending the LPP message of type PROVIDE LOCATION INFORMATION on the Uu interface. The response times specified for all test cases are Time-to-First-Fix (TTFF) unless otherwise stated, i.e. the UE shall not re-use any information on GNSS time, location or other aiding data that was previously acquired or calculated and stored internally in the UE. A dedicated test message 'RESET UE POSITIONING STORED INFORMATION' has been defined in TS 36.509 [11] clause 6.9 for the purpose of deleting this information.

### 4.5.4 Converting A-GNSS UE-assisted measurement reports into position estimates

To convert the A-GNSS UE measurement reports in case of UE-assisted mode of A-GNSS into position errors, a transformation between the "measurement domain" (code-phases, etc.) into the "state" domain (position estimate) is necessary. Such a transformation procedure is outlined in Annex B.

## 4.6 ECID test conditions

### 4.6.1 Simulated cells

For the ECID performance test cases in clause 8.1, a cell environment as defined in 3GPP TS 36.508 [18] with Cell 1 is used. The default parameters for simulated cells are the same as specified in 3GPP TS 36.508 [18], with the following exceptions:

[FFS]

### 4.6.2 Propagation conditions

#### 4.6.2.1 Static

See TS 36.521-1 [24] clause B.1.

#### 4.6.2.2 Multi-path fading

See TS 36.521-1[24] clauses B.2, B.2.1 and B.2.2.

### 4.6.3 UE Rx - Tx time difference reporting range

The reporting range of UE Rx - Tx time difference is defined from 0 to  $20472T_s$  with  $2T_s$  resolution for UE Rx - Tx time difference less than  $4096T_s$  and  $8T_s$  for UE Rx - Tx time difference equal to or greater than  $4096T_s$ .

The mapping of measured quantity is defined in Table 4.6.3-1.

**Table 4.6.3-1: UE Rx - Tx time difference measurement report mapping**

Reported value	Measured quantity value	Unit
RX-TX_TIME_DIFFERENCE_0000	$T_{UE\ Rx-Tx} < 2$	$T_s$
RX-TX_TIME_DIFFERENCE_0001	$2 \leq T_{UE\ Rx-Tx} < 4$	$T_s$
RX-TX_TIME_DIFFERENCE_0002	$4 \leq T_{UE\ Rx-Tx} < 6$	$T_s$
...	...	...
RX-TX_TIME_DIFFERENCE_2046	$4092 \leq T_{UE\ Rx-Tx} < 4094$	$T_s$
RX-TX_TIME_DIFFERENCE_2047	$4094 \leq T_{UE\ Rx-Tx} < 4096$	$T_s$
RX-TX_TIME_DIFFERENCE_2048	$4096 \leq T_{UE\ Rx-Tx} < 4104$	$T_s$
RX-TX_TIME_DIFFERENCE_2049	$4104 \leq T_{UE\ Rx-Tx} < 4112$	$T_s$
...	...	...
RX-TX_TIME_DIFFERENCE_4093	$20456 \leq T_{UE\ Rx-Tx} < 20464$	$T_s$
RX-TX_TIME_DIFFERENCE_4094	$20464 \leq T_{UE\ Rx-Tx} < 20472$	$T_s$
RX-TX_TIME_DIFFERENCE_4095	$20472 \leq T_{UE\ Rx-Tx}$	$T_s$

## 4.7 OTDOA test conditions

### 4.7.1 Simulated cells

For the intra-frequency OTDOA measurement test cases in clause 9.1, a multi cell environment as defined in 3GPP TS 36.508 [18] with Cell 1, Cell 2, and Cell 4 (if needed in the test) is used.

For the inter-frequency OTDOA measurement test cases in clause 9.2, a multi cell environment as defined in 3GPP TS 36.508 [18] with Cell 1 (called Cell 1 in the tests), Cell 3 (called Cell 2 in the tests), and Cell 6 (called Cell 3 in the tests) (if needed in the test) is used.

For the OTDOA measurement test cases for Carrier Aggregation in clause 10, a multi cell environment is used with Cell 1 as the PCell on the PCC, Cell 2 is an active SCell on the SCC, and Cell 3 is a neighbour cell on the SCC.

The default parameters for simulated cells are the same as specified in 3GPP TS 36.508 [18], with the following exceptions:

- All cells transmit PRS according to the PRS configuration provided in the OTDOA assistance data defined for each test. The positioning subframes are low-interference subframes, i.e. contain no PDSCH transmissions.
- The physical layer cell identities are selected such that the relative shifts of PRS patterns among cells used in the tests are as given by the test parameters of the individual test cases.
- The cells shall be synchronized and the timing offset (the RSTD) between the cells referenced to the UE's antenna input is given in the individual test cases.

## 4.7.2 Propagation conditions

### 4.7.2.1 Static

See TS 36.521-1 [24] clause B.1.

### 4.7.2.2 Multi-path fading

See TS 36.521-1 [24] clauses B.2, B.2.1 and B.2.2.

## 4.7.3 Response time

The response time is defined as the time starting from the moment that the UE has received the LPP message of type REQUEST LOCATION INFORMATION, and ending when the UE starts sending the LPP message of type PROVIDE LOCATION INFORMATION on the Uu interface. The response time specified for the Measurement Reporting Delay test cases assumes that the UE shall not re-use any RSTD information or other aiding data that was previously acquired and stored internally in the UE. A dedicated test message 'RESET UE POSITIONING STORED INFORMATION' has been defined in TS 36.509 [11] clause 6.9 for the purpose of deleting this information.

## 4.7.4 RSTD reporting range

The reporting range of RSTD is defined from  $-15391T_s$  to  $15391T_s$  with  $1T_s$  resolution for absolute value of RSTD less or equal to  $4096T_s$  and  $5T_s$  for absolute value of RSTD greater than  $4096T_s$ .

The mapping of measured quantity is defined in Table 4.7.4-1.

Table 4.7.4-1: RSTD report mapping

Reported Value	Measured Quantity Value	Unit
RSTD_0000	$-15391 > \text{RSTD}$	$T_s$
RSTD_0001	$-15391 \leq \text{RSTD} < -15386$	$T_s$
...	...	...
RSTD_2258	$-4106 \leq \text{RSTD} < -4101$	$T_s$
RSTD_2259	$-4101 \leq \text{RSTD} < -4096$	$T_s$
RSTD_2260	$-4096 \leq \text{RSTD} < -4095$	$T_s$
RSTD_2261	$-4095 \leq \text{RSTD} < -4094$	$T_s$
...	...	...
RSTD_6353	$-3 \leq \text{RSTD} < -2$	$T_s$
RSTD_6354	$-2 \leq \text{RSTD} < -1$	$T_s$
RSTD_6355	$-1 \leq \text{RSTD} \leq 0$	$T_s$
RSTD_6356	$0 < \text{RSTD} \leq 1$	$T_s$
RSTD_6357	$1 < \text{RSTD} \leq 2$	$T_s$
RSTD_6358	$2 < \text{RSTD} \leq 3$	$T_s$
...	...	...
RSTD_10450	$4094 < \text{RSTD} \leq 4095$	$T_s$
RSTD_10451	$4095 < \text{RSTD} \leq 4096$	$T_s$
RSTD_10452	$4096 < \text{RSTD} \leq 4101$	$T_s$
RSTD_10453	$4101 < \text{RSTD} \leq 4106$	$T_s$
...	...	...
RSTD_12709	$15381 < \text{RSTD} \leq 15386$	$T_s$
RSTD_12710	$15386 < \text{RSTD} \leq 15391$	$T_s$
RSTD_12711	$15391 < \text{RSTD}$	$T_s$

## 5 UTRA A-GPS Minimum Performance requirements

### 5.1 General

This clause defines the minimum performance requirements for FDD UTRA terminals where the only Assisted Global Navigation Satellite System (A-GNSS) supported is Assisted Global Positioning System (A-GPS) L1 C/A. The procedures for UEs that support other or additional A-GNSSs are specified in clause 6. This clause defines requirements for both UE based and UE assisted modes; if a terminal supports both modes then it shall be tested in both modes

The requirements in this clause are defined for CELL\_DCH and CELL\_FACH states. All tests shall be performed in CELL\_DCH state and the Nominal Accuracy Performance test case shall be also performed in CELL\_FACH state.

### 5.2 Sensitivity

#### 5.2.1 Sensitivity Coarse Time Assistance

##### 5.2.1.1 Definition and applicability

Sensitivity with coarse time assistance is the minimum level of GPS satellite signals required for the UE to make an A-GPS position estimate to a specific accuracy and within a specific response time when the network only provides coarse time assistance.

The requirements and this test apply to all types of UTRA for the FDD UE that supports A-GPS.

##### 5.2.1.2 Minimum requirements

The first fix position estimates shall meet the accuracy and response time requirements in table 5.2.1.2 for the parameters specified in table 5.2.1.1.

**Table 5.2.1.1: Test parameters for Sensitivity Coarse Time Assistance**

Parameters	Unit	Value
Number of generated satellites	-	8
HDOP Range	-	1.1 to 1.6
Propagation conditions	-	AWGN
GPS Coarse Time assistance error range	seconds	$\pm 2$
GPS Signal for one satellite	dBm	-142
GPS Signal for remaining satellites	dBm	-147

**Table 5.2.1.2: Minimum requirements for Sensitivity Coarse Time Assistance**

Success rate	2-D position error	Max response time
95 %	100 m	20 s

The reference for this requirement is 3GPP TS 25.171 [31], clause 5.1.1.1.

##### 5.2.1.3 Test purpose

To verify the UE's first position estimate meets the minimum requirements under GPS satellite signal conditions that represent weak signal conditions and with only Coarse Time Assistance provided by the SS.

## 5.2.1.4 Method of test

### 5.2.1.4.1 Initial conditions

Test environment: normal; see Annex G.

1. Connect SS and GSS to the UE antenna connector or antenna connectors as shown in figures A.1 or A.2.
2. Set the GPS test parameters as specified in table 5.2.1.3 for GPS scenario #1. Select the first satellite PRN defined in the table in 3GPP TS 37.571-5 [20] clause 5.2.1.2.5 for the one satellite with the higher level.
3. Switch on the UE.

### 5.2.1.4.2 Procedure

1. Start GPS scenario #1 as specified in 3GPP TS 37.571-5 [20] clause 5.2.1.2 with the UE location randomly selected to be within 3 km of the Reference Location and the altitude of the UE randomly selected between 0 m to 500 m above WGS-84 reference ellipsoid using the method described in 3GPP TS 37.571-5 [20] clause 5.2.1.2.4
2. Set up a connection using the procedure in clause F.2.
3. Send a RESET UE POSITIONING STORED INFORMATION message followed by RRC MEASUREMENT CONTROL messages containing appropriate assistance data; as specified in 3GPP TS 37.571-5 [20], clauses 5.2.2 and 5.2.6 for UE based testing; or clauses 5.2.4 and 5.2.6 for UE assisted testing with the value of GPS TOW msec offset by a random value as specified in 3GPP TS 37.571-5 [20] clause 5.2.6.2; as required to obtain a fix using the procedure specified in 3GPP TS 34.108 [28], clauses 7.5.1 or 7.5.4.
4. If the UE returns a valid result in the MEASUREMENT REPORT message within the Max response time specified in table 5.2.1.4 then record the result and process it as specified in step 5. If the UE does not return a valid result within the Max response time specified in table 5.2.1.4 or reports a UE positioning error in the MEASUREMENT REPORT message then record one Bad Result.
5. For UE based testing compare the reported position estimate in the MEASUREMENT REPORT message against the simulated position of the UE used in step 1, and calculate the 2D position error as specified in clause 4.5.2.3. Compare the 2D position error against the value in table 5.2.1.4 and record one Good Result or Bad Result as appropriate; or

For UE assisted testing convert the GPS measured results reported in the MEASUREMENT REPORT message to a 2D position using the method described in Annex B and then compare the result against the simulated position of the UE, used in step 1, and calculate the 2D position error as specified in clause 4.5.2.3. Compare the 2D position error against the value in table 5.2.1.4 and record one Good Result or Bad Result as appropriate.

6. Release the connection using the procedure in clause F.3.
7. Repeat steps 1 to 6 using GPS scenario #2 instead of #1 so that the reference location changes sufficiently such that the UE shall have to use the new assistance data. Select the first satellite PRN defined in the table in 3GPP TS 37.571-5 [20] clause 5.2.1.2.5 for the one satellite with the higher level. Use new random values for the UE location and altitude in step 1 and for the GPS TOW msec offset in step 3.
8. Repeat steps 1 to 7 until the statistical requirements of clause 5.2.1.5 are met. Each time scenario #1 or #2 is used, the start time of the GPS scenario shall be advanced by 2 minutes from the time used previously for that scenario. Once a scenario reaches the end of its viable running time, restart it from its nominal start time again. Each time scenario #1 or #2 is used select the next satellite PRN from the one used previously, defined in the table in 3GPP TS 37.571-5 [20] clause 5.2.1.2.5, for the one satellite with the higher level.

### 5.2.1.5 Test Requirements

For the parameters specified in table 5.2.1.3 the UE shall meet the requirements and the success rate specified in table 5.2.1.4 with a confidence level of 95% according to annex D.

**Table 5.2.1.3: Test parameters for Sensitivity Coarse Time Assistance**

Parameters	Unit	Value
Number of generated satellites	-	8
HDOP Range	-	1.1 to 1.6
Propagation conditions	-	AWGN
GPS Coarse Time assistance error range	seconds	$\pm 1.8$
GPS Signal for one satellite	dBm	-141
GPS Signal for remaining satellites	dBm	-146

**Table 5.2.1.4: Test requirements for Sensitivity Coarse Time Assistance**

Success rate	2-D position error	Max response time
95 %	101.3 m	20.3 s

NOTE: If the above Test Requirement differs from the Minimum Requirement then the Test Tolerance applied for this test is non-zero. The Test Tolerance for this test is defined in clause C.2 and the explanation of how the Minimum Requirement has been relaxed by the Test Tolerance is given in clause C.4.

## 5.2.2 Sensitivity Fine Time Assistance

### 5.2.2.1 Definition and applicability

Sensitivity with fine time assistance is the minimum level of GPS satellite signals required for the UE to make an A-GPS position estimate to a specific accuracy and within a specific response time when the network provides fine time assistance in addition to coarse time assistance.

The requirements and this test apply to all types of UTRA for the FDD UE that supports A-GPS and that is capable of providing an enhanced performance when the network provides Fine Time Assistance.

### 5.2.2.2 Minimum requirements

The first fix position estimates shall meet the accuracy and response time requirements in table 5.2.2.2 for the parameters specified in table 5.2.2.1.

**Table 5.2.2.1: Test parameters for Sensitivity Fine Time Assistance**

Parameters	Unit	Value
Number of generated satellites	-	8
HDOP Range	-	1.1 to 1.6
Propagation conditions	-	AWGN
GPS Coarse time assistance error range	seconds	$\pm 2$
GPS Fine Time assistance error range	$\mu\text{s}$	$\pm 10$
GPS Signal for all satellites	dBm	-147

**Table 5.2.2.2: Minimum requirements for Sensitivity Fine Time Assistance**

Success rate	2-D position error	Max response time
95 %	100 m	20 s

The reference for this requirement is 3GPP TS 25.171 [31], clause 5.1.2.1.



### 5.2.2.3 Test purpose

To verify the UE's first position estimate meets the minimum requirements under GPS satellite signal conditions that represent weak signal conditions and with Fine Time Assistance provided by the SS.

### 5.2.2.4 Method of test

#### 5.2.2.4.1 Initial conditions

Test environment: normal; see Annex G.

1. Connect SS and GSS to the UE antenna connector or antenna connectors as shown in figures A.1 or A.2.
2. Set the GPS test parameters as specified in table 5.2.2.3 for GPS scenario #1.
3. Switch on the UE.

#### 5.2.2.4.2 Procedure

1. Start GPS scenario #1 as specified in 3GPP TS 37.571-5 [20] clause 5.2.1.2 with the UE location randomly selected to be within 3 km of the Reference Location and the altitude of the UE randomly selected between 0 m to 500 m above WGS-84 reference ellipsoid using the method described in 3GPP TS 37.571-5 [20] clause 5.2.1.2.4
2. Set up a connection using the procedure in clause F.2.
3. Send a RESET UE POSITIONING STORED INFORMATION message followed by RRC MEASUREMENT CONTROL messages containing appropriate assistance data; as specified in 3GPP TS 37.571-5 [20], clauses 5.2.2 and 5.2.6 for UE based testing; or clauses 5.2.4 and 5.2.6 for UE assisted testing with the values of GPS TOW msec and UTRAN GPS timing of cell frames offset by random values as specified in 3GPP TS 37.571-5 [20] clause 5.2.6.2; as required to obtain a fix using the procedure specified in 3GPP TS 34.108 [28], clauses 7.5.1 or 7.5.4.
4. If the UE returns a valid result in the MEASUREMENT REPORT message within the Max response time specified in table 5.2.2.4 then record the result and process it as specified in step 5. If the UE does not return a valid result within the Max response time specified in table 5.2.2.4 or reports a UE positioning error in the MEASUREMENT REPORT message then record one Bad Result.
5. For UE based testing compare the reported position estimate in the MEASUREMENT REPORT message against the simulated position of the UE used in step 1, and calculate the 2D position error as specified in clause 4.5.2.3. Compare the 2D position error against the value in table 5.2.2.4 and record one Good Result or Bad Result as appropriate; or  
  
For UE assisted testing convert the GPS measured results reported in the MEASUREMENT REPORT message to a 2D position using the method described in Annex B and then compare the result against the simulated position of the UE used in step 1, and calculate the 2D position error as specified in clause 4.5.2.3. Compare the 2D position error against the value in table 5.2.2.4 and record one Good Result or Bad Result as appropriate.
6. Release the connection using the procedure in clause F.3.
7. Repeat steps 1 to 6 using GPS scenario #2 instead of #1 so that the reference location changes sufficiently such that the UE shall have to use the new assistance data. Use new random values for the UE location and altitude in step 1 and for the GPS TOW msec and UTRAN GPS timing of cell frames offsets in step 3.
8. Repeat steps 1 to 7 until the statistical requirements of clause 5.2.2.5 are met. Each time scenario #1 or #2 is used, the start time of the GPS scenario shall be advanced by 2 minutes from the time used previously for that scenario. Once a scenario reaches the end of its viable running time, restart it from its nominal start time again.

### 5.2.2.5 Test Requirements

For the parameters specified in table 5.2.2.3 the UE shall meet the requirements and the success rate specified in table 5.2.2.4 with a confidence level of 95% according to annex D.

**Table 5.2.2.3: Test parameters for Sensitivity Fine Time Assistance**

Parameters	Unit	Value
Number of generated satellites	-	8
HDOP Range	-	1.1 to 1.6
Propagation conditions	-	AWGN
GPS Coarse time assistance error range	seconds	$\pm 1.8$
GPS Fine Time assistance error range	$\mu\text{s}$	$\pm 9$
GPS Signal for all satellites	dBm	-146

**Table 5.2.2.4: Test requirements for Sensitivity Fine Time Assistance**

Success rate	2-D position error	Max response time
95 %	101.3 m	20.3 s

NOTE: If the above Test Requirement differs from the Minimum Requirement then the Test Tolerance applied for this test is non-zero. The Test Tolerance for this test is defined in clause C.2 and the explanation of how the Minimum Requirement has been relaxed by the Test Tolerance is given in clause C.4.

## 5.3 Nominal Accuracy

### 5.3.1 Definition and applicability

Nominal accuracy is the accuracy of the UE's A-GPS position estimate under ideal GPS signal conditions.

The requirements and this test apply to all types of UTRA for the FDD UE that supports A-GPS.

### 5.3.2 Minimum requirements

The first fix position estimates shall meet the accuracy and response time requirements in table 5.3.2 for the parameters specified in table 5.3.1.

**Table 5.3.1: Test parameters for Nominal Accuracy**

Parameters	Unit	Value
Number of generated satellites	-	8
HDOP Range	-	1.1 to 1.6
Propagation conditions	-	AWGN
GPS Coarse Time assistance error range	seconds	$\pm 2$
GPS Signal for all satellites	dBm	-130

**Table 5.3.2: Minimum requirements for Nominal Accuracy**

Success rate	2-D position error	Max response time
95 %	30 m	20 s

The reference for this requirement is 3GPP TS 25.171 [31], clause 5.2.1.

### 5.3.3 Test purpose

To verify the UE's first position estimate meets the minimum requirements under GPS satellite signal conditions that represent ideal conditions.

## 5.3.4 Method of test

### 5.3.4.1 Initial conditions

Test environment: normal; see Annex G.

1. Connect SS and GSS to the UE antenna connector or antenna connectors as shown in figures A.1 or A.2.
2. Set the GPS test parameters as specified in table 5.3.3 for GPS scenario #1.
3. Switch on the UE.

### 5.3.4.2 Procedure

1. Start GPS scenario #1 as specified in 3GPP TS 37.571-5 [20] clause 5.2.1.2 with the UE location randomly selected to be within 3 km of the Reference Location and the altitude of the UE randomly selected between 0 m to 500 m above WGS-84 reference ellipsoid using the method described in 3GPP TS 37.571-5 [20] clause 5.2.1.2.4
2. Set up a connection using the procedure in clause F.2.
3. Send a RESET UE POSITIONING STORED INFORMATION message followed by RRC MEASUREMENT CONTROL messages containing appropriate assistance data; as specified in 3GPP TS 37.571-5 [20], clauses 5.2.2 and 5.2.6 for UE based testing; or clauses 5.2.4 and 5.2.6 for UE assisted testing with the value of GPS TOW msec offset by a random value as specified in 3GPP TS 37.571-5 [20] clause 5.2.6.2; using the exception to the RRC MEASUREMENT CONTROL message listed in table 5.3.2A; as required to obtain a fix using the procedure specified in 3GPP TS 34.108 [28], clauses 7.5.1 or 7.5.4.

**Table 5.3.2A: Contents of RRC MEASUREMENT CONTROL message**

Information Element	Value/Remark
- UE positioning reporting quantity - Horizontal accuracy	10 (15.9 m)

4. If the UE returns a valid result in the MEASUREMENT REPORT message within the Max response time specified in table 5.3.4 then record the result and process it as specified in step 5. If the UE does not return a valid result within the Max response time specified in table 5.3.4 or reports a UE positioning error in the MEASUREMENT REPORT message then record one Bad Result.
5. For UE based testing compare the reported position estimate in the MEASUREMENT REPORT message against the simulated position of the UE used in step 1, and calculate the 2D position error as specified in clause 4.5.2.3. Compare the 2D position error against the value in table 5.3.4 and record one Good Result or Bad Result as appropriate; or

For UE assisted testing convert the GPS measured results reported in the MEASUREMENT REPORT message to a 2D position using the method described in Annex B and then compare the result against the simulated position of the UE used in step 1, and calculate the 2D position error as specified in clause 4.5.2.3. Compare the 2D position error against the value in table 5.3.4 and record one Good Result or Bad Result as appropriate.

6. Release the connection using the procedure in clause F.3.
7. Repeat steps 1 to 6 using GPS scenario #2 instead of #1 so that the reference location changes sufficiently such that the UE shall have to use the new assistance data. Use new random values for the UE location and altitude in step 1 and for the GPS TOW msec offset in step 3.
8. Repeat steps 1 to 7 until the statistical requirements of clause 5.3.5 are met. Each time scenario #1 or #2 is used, the start time of the GPS scenario shall be advanced by 2 minutes from the time used previously for that scenario. Once a scenario reaches the end of its viable running time, restart it from its nominal start time again.

## 5.3.5 Test Requirements

For the parameters specified in table 5.3.3 the UE shall meet the requirements and the success rate specified in table 5.3.4 with a confidence level of 95% according to annex D.

**Table 5.3.3: Test parameters for Nominal Accuracy**

Parameters	Unit	Value
Number of generated satellites	-	8
HDOP Range	-	1.1 to 1.6
Propagation conditions	-	AWGN
GPS Coarse Time assistance error range	seconds	$\pm 1.8$
GPS Signal for all satellites	dBm	-130

**Table 5.3.4: Test requirements for Nominal Accuracy**

Success rate	2-D position error	Max response time
95 %	31.3 m	20.3 s

NOTE: If the above Test Requirement differs from the Minimum Requirement then the Test Tolerance applied for this test is non-zero. The Test Tolerance for this test is defined in clause C.2 and the explanation of how the Minimum Requirement has been relaxed by the Test Tolerance is given in clause C.4.

## 5.4 Dynamic Range

### 5.4.1 Definition and applicability

Dynamic Range is the maximum difference in level of the GPS signals from a number of satellites that allows the UE to make an A-GPS position estimate with a specific accuracy and a specific response time.

The requirements and this test apply to all types of UTRA for the FDD UE that supports A-GPS.

### 5.4.2 Minimum requirements

The first fix position estimates shall meet the accuracy and response time requirements in table 5.4.2 for the parameters specified in table 5.4.1.

**Table 5.4.1: Test parameters for Dynamic Range**

Parameters	Unit	Value
Number of generated satellites	-	6
HDOP Range	-	1.4 to 2.1
GPS Coarse Time assistance error range	seconds	$\pm 2$
Propagation conditions	-	AWGN
GPS Signal for 1 <sup>st</sup> satellite	dBm	-129
GPS Signal for 2 <sup>nd</sup> satellite	dBm	-135
GPS Signal for 3 <sup>rd</sup> satellite	dBm	-141
GPS Signal for 4 <sup>th</sup> satellite	dBm	-147
GPS Signal for 5 <sup>th</sup> satellite	dBm	-147
GPS Signal for 6 <sup>th</sup> satellite	dBm	-147

**Table 5.4.2: Minimum requirements for Dynamic Range**

Success rate	2-D position error	Max response time
95 %	100 m	20 s

The reference for this requirement is 3GPP TS 25.171 [31], clause 5.3.1.

### 5.4.3 Test purpose

To verify the UE's first position estimate meets the minimum requirements under GPS satellite signal conditions that have a wide dynamic range. Strong satellites are likely to degrade the acquisition of weaker satellites due to their cross-correlation products.

### 5.4.4 Method of test

#### 5.4.4.1 Initial conditions

Test environment: normal; see Annex G.

1. Connect SS and GSS to the UE antenna connector or antenna connectors as shown in figures A.1 or A.2.
2. Set the GPS test parameters as specified in table 5.4.3 for GPS scenario #1. Select the first three satellite PRNs defined in the table in 3GPP TS 37.571-5 [20] clause 5.2.1.2.5 for the three satellites with the higher levels.
3. Switch on the UE.

#### 5.4.4.2 Procedure

1. Start GPS scenario #1 as specified in 3GPP TS 37.571-5 [20] clause 5.2.1.2 with the UE location randomly selected to be within 3 km of the Reference Location and the altitude of the UE randomly selected between 0 m to 500 m above WGS-84 reference ellipsoid using the method described in 3GPP TS 37.571-5 [20] clause 5.2.1.2.4
2. Set up a connection using the procedure in clause F.2.
3. Send a RESET UE POSITIONING STORED INFORMATION message followed by RRC MEASUREMENT CONTROL messages containing appropriate assistance data; as specified in 3GPP TS 37.571-5 [20], clauses 5.2.2 and 5.2.6 for UE based testing; or clauses 5.2.4 and 5.2.6 for UE assisted testing with the value of GPS TOW msec offset by a random value as specified in 3GPP TS 37.571-5 [20] clause 5.2.6.2; as required to obtain a fix using the procedure specified in 3GPP TS 34.108 [28], clauses 7.5.1 or 7.5.4.
4. If the UE returns a valid result in the MEASUREMENT REPORT message within the Max response time specified in table 5.4.4 then record the result and process it as specified in step 5. If the UE does not return a valid result within the Max response time specified in table 5.4.4 or reports a UE positioning error in the MEASUREMENT REPORT message then record one Bad Result.
5. For UE based testing compare the reported position estimate in the MEASUREMENT REPORT message against the simulated position of the UE used in step 1, and calculate the 2D position error as specified in clause 4.5.2.3. Compare the 2D position error against the value in table 5.4.4 and record one Good Result or Bad Result as appropriate; or

For UE assisted testing convert the GPS measured results reported in the MEASUREMENT REPORT message to a 2D position using the method described in Annex B and then compare the result against the simulated position of the UE used in step 1, and calculate the 2D position error as specified in clause 4.5.2.3. Compare the 2D position error against the value in table 5.4.4 and record one Good Result or Bad Result as appropriate.

6. Release the connection using the procedure in clause F.3.
7. Repeat steps 1 to 6 using GPS scenario #2 instead of #1 so that the reference location changes sufficiently such that the UE shall have to use the new assistance data. Select the first three satellite PRNs defined in the table in 3GPP TS 37.571-5 [20] clause 5.2.1.2.5 for the three satellites with the higher levels. Use new random values for the UE location and altitude in step 1 and for the GPS TOW msec offset in step 3.
8. Repeat steps 1 to 7 until the statistical requirements of clause 5.4.5 are met. Each time scenario #1 or #2 is used, the start time of the GPS scenario shall be advanced by 2 minutes from the time used previously for that scenario. Once a scenario reaches the end of its viable running time, restart it from its nominal start time again. Each time scenario #1 or #2 is used, increment the set of three satellite PRNs by one from the ones used

previously, defined in the table in 3GPP TS 37.571-5 [20] clause 5.2.1.2.5, for the three satellites with the higher levels (i.e. if the set of satellites is a, b, c, d, e, f and the first set used was a, b, c, the second set shall be b, c, d and so on).

## 5.4.5 Test Requirements

For the parameters specified in table 5.4.3 the UE shall meet the requirements and the success rate specified in table 5.4.4 with a confidence level of 95% according to annex D.

**Table 5.4.3: Test parameters for Dynamic Range**

Parameters	Unit	Value
Number of generated satellites	-	6
HDOP Range	-	1.4 to 2.1
GPS Coarse Time assistance error range	seconds	$\pm 2 + TT$
Propagation conditions	-	AWGN
GPS Signal for 1 <sup>st</sup> satellite	dBm	-128.2
GPS Signal for 2 <sup>nd</sup> satellite	dBm	-134
GPS Signal for 3 <sup>rd</sup> satellite	dBm	-140
GPS Signal for 4 <sup>th</sup> satellite	dBm	-146
GPS Signal for 5 <sup>th</sup> satellite	dBm	-146
GPS Signal for 6 <sup>th</sup> satellite	dBm	-146

**Table 5.4.4: Test requirements for Dynamic Range**

Success rate	2-D position error	Max response time
95 %	101.3 m	20.3 s

NOTE: If the above Test Requirement differs from the Minimum Requirement then the Test Tolerance applied for this test is non-zero. The Test Tolerance for this test is defined in clause C.2 and the explanation of how the Minimum Requirement has been relaxed by the Test Tolerance is given in clause C.4.

## 5.5 Multi-path Performance

### 5.5.1 Definition and applicability

Multi-path performance measures the accuracy and response time of the UE's A-GPS position estimate in a specific GPS signal multi-path environment.

The requirements and this test apply to all types of UTRA for the FDD UE that supports A-GPS.

### 5.5.2 Minimum requirements

The first fix position estimates shall meet the accuracy and response time requirements in table 5.5.2 for the parameters specified in table 5.5.1.

**Table 5.5.1: Test parameters for Multi-path Performance**

Parameters	Unit	Value
Number of generated satellites (see note)	-	5
GPS Coarse Time assistance error range	seconds	$\pm 2$
HDOP Range	-	1.8 to 2.5
GPS signal for Satellite 1, 2 (see note)	dBm	-130
GPS signal for Satellite 3, 4, 5 (see note)	dBm	LOS signal of -130 dBm, multi-path signal of -136 dBm

NOTE: Satellites 1, 2 no multi-path. Satellites 3, 4, 5 multi-path defined in clause 4.2.4.

**Table 5.5.2: Minimum requirements for Multi-path Performance**

Success rate	2-D position error	Max response time
95 %	100 m	20 s

The reference for this requirement is 3GPP TS 25.171 [31], clause 5.4.1.

### 5.5.3 Test purpose

To verify the UE's first position estimate meets the minimum requirements under GPS satellite signal conditions that represent simple multi-path conditions.

### 5.5.4 Method of test

#### 5.5.4.1 Initial conditions

Test environment: normal; see Annex G.

1. Connect SS and GSS to the UE antenna connector or antenna connectors as shown in figures A.1 or A.2.
2. Set the GPS test parameters as specified in table 5.5.3 for GPS scenario #1. Select the first two satellite PRNs defined in the table in 3GPP TS 37.571-5 [20] clause 5.2.1.2.5 for the two satellites with the higher levels.
3. Switch on the UE.

#### 5.5.4.2 Procedure

1. Start GPS scenario #1 as specified in 3GPP TS 37.571-5 [20] clause 5.2.1.2 with the UE location randomly selected to be within 3 km of the Reference Location and the altitude of the UE randomly selected between 0 m to 500 m above WGS-84 reference ellipsoid using the method described in 3GPP TS 37.571-5 [20] clause 5.2.1.2.4. The initial carrier phase difference between taps of the multi-path model shall be randomly selected between 0 and  $2\pi$  radians by selecting the next random number from a standard uniform random number generator, in the range 0 to  $2\pi$ , representing radians with a resolution of 0.1, representing 0.1 radians.
2. Set up a connection using the procedure in clause F.2.
3. Send a RESET UE POSITIONING STORED INFORMATION message followed by RRC MEASUREMENT CONTROL messages containing appropriate assistance data; as specified in 3GPP TS 37.571-5 [20], clauses 5.2.2 and 5.2.6 for UE based testing; or clauses 5.2.4 and 5.2.6 for UE assisted testing with the value of GPS TOW msec offset by a random value as specified in 3GPP TS 37.571-5 [20] clause 5.2.6.2; as required to obtain a fix using the procedure specified in 3GPP TS 34.108 [28], clauses 7.5.1 or 7.5.4.
4. If the UE returns a valid result in the MEASUREMENT REPORT message within the Max response time specified in table 5.5.4 then record the result and process it as specified in step 5. If the UE does not return a valid result within the Max response time specified in table 5.5.4 or reports a UE positioning error in the MEASUREMENT REPORT message then record one Bad Result.
5. For UE based testing compare the reported position estimate in the MEASUREMENT REPORT message against the simulated position of the UE used in step 1, and calculate the 2D position error as specified in clause 4.5.2.3. Compare the 2D position error against the value in table 5.5.4 and record one Good Result or Bad Result as appropriate; or

For UE assisted testing convert the GPS measured results reported in the MEASUREMENT REPORT message to a 2D position using the method described in Annex B and then compare the result against the simulated position of the UE used in step 1, and calculate the 2D position error as specified in clause 4.5.2.3. Compare the 2D position error against the value in table 5.5.4 and record one Good Result or Bad Result as appropriate.

6. Release the connection using the procedure in clause F.3.
7. Repeat steps 1 to 6 using GPS scenario #2 instead of #1 so that the reference location changes sufficiently such that the UE shall have to use the new assistance data. Select the first two satellite PRNs defined in the table in

3GPP TS 37.571-5 [20] clause 5.2.1.2.5 for the two satellites with the higher levels. Use new random values for the UE location and altitude, and the initial carrier phase difference between taps of the multi-path model in step 1 and for the GPS TOW msec offset in step 3.

8. Repeat steps 1 to 7 until the statistical requirements of clause 5.5.5 are met. Each time scenario #1 or #2 is used, the start time of the GPS scenario shall be advanced by 2 minutes from the time used previously for that scenario. Once a scenario reaches the end of its viable running time, restart it from its nominal start time again. Each time scenario #1 or #2 is used, increment the set of two satellite PRNs by one from the ones used previously, defined in the table in 3GPP TS 37.571-5 [20] clause 5.2.1.2.5, for the two satellites with the higher level (i.e. if the set of satellites is a, b, c, d, e and the first set used was a, b the second set shall be b, c and so on).

## 5.5.5 Test Requirements

For the parameters specified in table 5.5.3 the UE shall meet the requirements and the success rate specified in table 5.5.4 with a confidence level of 95% according to annex D.

**Table 5.5.3: Test parameters for Multi-path Performance**

Parameters	Unit	Value
Number of generated satellites (see note)	-	5
GPS Coarse Time assistance error range	seconds	$\pm 2+TT$
HDOP Range	-	1.8 to 2.5
GPS signal for Satellite 1, 2 (see note)	dBm	-130
GPS signal for Satellite 3, 4, 5 (see note)	dBm	LOS signal of -130 dBm, multi-path signal of -136.2 dBm
NOTE: Satellites 1, 2 no multi-path. Satellites 3, 4, 5 multi-path defined in clause 4.2.4.		

**Table 5.5.4: Test requirements for Multi-path Performance**

Success rate	2-D position error	Max response time
95 %	101.3 m	20.3 s

NOTE: If the above Test Requirement differs from the Minimum Requirement then the Test Tolerance applied for this test is non-zero. The Test Tolerance for this test is defined in clause C.2 and the explanation of how the Minimum Requirement has been relaxed by the Test Tolerance is given in clause C.4.

## 5.6 Moving Scenario and Periodic Update Performance

### 5.6.1 Definition and applicability

Moving scenario and periodic update performance measures the accuracy of the UE's A-GPS position estimates and the periodic update capability of the UE in a moving scenario.

The requirements and this test apply to all types of UTRA for the FDD UE that supports A-GPS.

### 5.6.2 Minimum requirements

The position estimates, after the first reported position estimate, shall meet the accuracy requirement in table 5.6.2 with the periodical reporting interval of 2 seconds for the parameters specified in table 5.6.1.

NOTE: In the actual testing the UE may report error messages until it has been able to acquire GPS measured results or a position estimate. The SS shall only consider the first measurement report different from an error message as the first position estimate in the requirement in table 5.6.2.



**Table 5.6.1: Test parameters for Moving Scenario and Periodic Update Performance**

Parameters	Unit	Value
Number of generated satellites	-	5
HDOP Range	-	1.8 to 2.5
Propagation condition	-	AWGN
GPS signal for all satellites	dBm	-130

**Table 5.6.2: Minimum requirements for Moving Scenario and Periodic Update Performance**

Success Rate	2-D position error
95 %	100 m

The reference for this requirement is 3GPP TS 25.171 [31], clause 5.5.1.

### 5.6.3 Test purpose

To verify the UE's position estimates, after the first reported position estimate, meet the minimum requirements under GPS satellite signal conditions that simulate a moving scenario. A good tracking performance, with regular position estimate reporting is essential for certain location services.

### 5.6.4 Method of test

#### 5.6.4.1 Initial conditions

Test environment: normal; see Annex G.

The UE is requested to use periodical reporting with a reporting interval of 2 seconds.

The GPS signals simulate the UE moving on a rectangular trajectory of 940 m by 1 440 m with rounded corners defined in figure 5.6.1 and table 5.6.3. The initial reference is first defined followed by acceleration to final speed of 100 km/h in 250 m. The UE then maintains the speed for 400 m. This is followed by deceleration to final speed of 25 km/h in 250 m. The UE then turn 90 degrees with turning radius of 20 m at 25 km/h. This is followed by acceleration to final speed of 100 km/h in 250 m. The sequence is repeated to complete the rectangle.

**Table 5.6.3: Trajectory Parameters for Moving Scenario and Periodic Update Performance test case**

Parameter	Distance (m)	Speed (km/h)
$l_{11}, l_{15}, l_{21}, l_{25}$	20	25
$l_{12}, l_{14}, l_{22}, l_{24}$	250	25 to 100 and 100 to 25
$l_{13}$	400	100
$l_{23}$	900	100

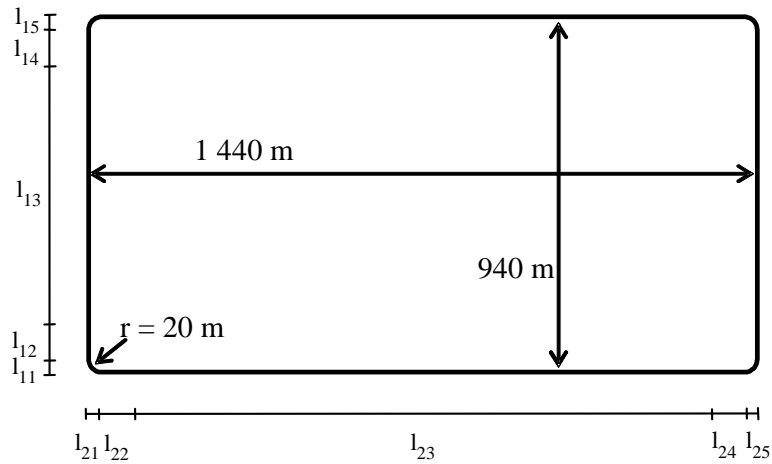

**Figure 5.6.1: Rectangular Trajectory for Moving Scenario and Periodic Update Performance test case**

1. Connect SS and GSS to the UE antenna connector or antenna connectors as shown in figures A.1 or A.2.
2. Set the GPS test parameters as specified in table 5.6.4 for GPS scenario #3.
3. Switch on the UE.
4. Set up a connection using the procedure in clause F.2.

#### 5.6.4.2 Procedure

1. Start GPS scenario #3 as specified in 3GPP TS 37.571-5 [20], clause 5.2.1.2
2. Send a RESET UE POSITIONING STORED INFORMATION message followed by RRC MEASUREMENT CONTROL messages containing appropriate assistance data; as specified in 3GPP TS 37.571-5 [20], clauses 5.2.2 and 5.2.6 for UE based testing; or clauses 5.2.4 and 5.2.6 for UE assisted testing; as required to obtain fixes using the procedure specified in 3GPP TS 34.108 [28], clauses 7.5.2 or 7.5.5.
3. Ignore any error messages that the UE may report in MEASUREMENT REPORT messages until it has been able to acquire the GPS signals and reports the first GPS measured result or position estimate.
4. Discard the first GPS measured result or position estimate.
5. Record the time of reception of the next MEASUREMENT REPORT message after reception of the first GPS measured result or position estimate.
6. After the reception of the first GPS measured result or position estimate reported in a MEASUREMENT REPORT message, every time the UE returns a GPS measured result or position estimate in the MEASUREMENT REPORT message record the time of reception and the result. If the difference between the time of reception and the time of reception of the previous result is less than 1.5 seconds or greater than 2.5 seconds, or if the UE reports a UE positioning error in any MEASUREMENT REPORT messages, then record one Bad Result. Otherwise process the result as specified in step 7.
7. For UE based testing compare the reported position estimate in the MEASUREMENT REPORT message against the simulated position of the UE at the time of applicability reported in the position estimate and calculate the 2D position error as specified in clause 4.5.2.3. Compare the 2D position error against the value in table 5.6.5 and record one Good Result or Bad Result as appropriate; or

For UE assisted testing convert the GPS measured results reported in the MEASUREMENT REPORT message to a 2D position using the method described in Annex B and then compare the result against the simulated position of the UE at the time of applicability reported in the GPS measured results and calculate the 2D position error as specified in clause 4.5.2.3. Compare the 2D position error against the value in table 5.6.5 and record one Good Result or Bad Result as appropriate.

8. If the UE sends the first MEASUREMENT REPORT that contains a measured result or position estimate later than 240s after the start of the GPS scenario, fail the UE and stop the test early. Otherwise collect

MEASUREMENT REPORTs during 900s, starting from the time recorded in step 5. If at any time the difference between the times of reception of two consecutive results is greater than 240s, fail the UE and stop the test early. Use the collected Good Results and Bad Results to determine the PASS/FAIL according to clause 5.6.5.

9. Release the connection using the procedure in clause F.3.

## 5.6.5 Test Requirements

For the parameters specified in table 5.6.4, after the first reported position estimate, the UE shall meet the accuracy requirement and the success rate specified in table 5.6.5 with a periodical reporting interval of 2 seconds +/- 20% plus measurement system uncertainty of 100ms.

NOTE: Due to the statistical nature of the results it is not possible to design a test with predefined confidence level for the success rate in Table 5.6.5, therefore a simple PASS/FAIL of the results gathered against this success rate is used.

**Table 5.6.4: Test parameters for Moving Scenario and Periodic Update Performance**

Parameters	Unit	Value
Number of generated satellites	-	5
HDOP Range	-	1.8 to 2.5
Propagation condition	-	AWGN
GPS signal for all satellites	dBm	-130

**Table 5.6.5: Test requirements for Moving Scenario and Periodic Update Performance**

Success Rate	2-D position error
95 %	101.3 m

NOTE 1: If the above Test Requirement differs from the Minimum Requirement then the Test Tolerance applied for this test is non-zero. The Test Tolerance for this test is defined in clause C.2 and the explanation of how the Minimum Requirement has been relaxed by the Test Tolerance is given in clause C.4.

NOTE 2: In the actual testing the UE may report error messages until it has been able to acquire GPS measured results or a position estimate. The test equipment shall only consider the first measurement report different from an error message as the first position estimate in the requirement in table 5.6.5.

## 6 UTRA A-GNSS Minimum Performance requirements

### 6.1 General

This clause defines the minimum performance requirements for both UE based and UE assisted FDD A-GNSS UTRA terminals. If a terminal supports both modes then it shall be tested in both modes. It excludes performance requirements for UEs where the only A-GNSS supported is A-GPS L1C/A which are specified in clause 5.

The requirements are defined for CELL\_DCH and CELL\_FACH states. All tests shall be performed in CELL\_DCH state and the Nominal Accuracy Performance test case shall be also performed in CELL\_FACH state.

### 6.2 Sensitivity

#### 6.2.1 Sensitivity Coarse Time Assistance

##### 6.2.1.1 Definition and applicability

Sensitivity with coarse time assistance is the minimum level of GNSS satellite signals required for the UE to make an A-GNSS position estimate to a specific accuracy and within a specific response time when the network only provides coarse time assistance.

The requirements and this test apply to all types of UTRA for the FDD UE that supports A-GNSS.

This test case includes sub-test cases dependent on the GNSS supported by the UE. Each sub-test case is identified by a Sub-Test Case Number as defined in Table 6.2.1.1.

**Table 6.2.1.1: Sub-Test Case Number Definition**

Sub-Test Case Number	Supported GNSS
1	UE supporting A-GLONASS only
2	UE supporting A-Galileo only
3	UE supporting A-GPS and Modernized GPS only
4	UE supporting A-GPS and A-GLONASS only

##### 6.2.1.2 Minimum requirements

The first fix position estimates shall meet the accuracy and response time requirements in table 6.2.1.2-3 for the parameters specified in table 6.2.1.2-1.

**Table 6.2.1.2-1: Test parameters for Sensitivity Coarse Time Assistance**

System	Parameters	Unit	Value
	Number of generated satellites per system	-	See Table 6.2.1.2-2
	Total number of generated satellites	-	6
	HDOP range		1.4 to 2.1
	Propagation conditions	-	AWGN
	GNSS coarse time assistance error range	seconds	±2
Galileo	Reference high signal power level	dBm	-142
	Reference low signal power level	dBm	-147
GPS <sup>(1)</sup>	Reference high signal power level	dBm	-142
	Reference low signal power level	dBm	-147
GLONASS	Reference high signal power level	dBm	-142
	Reference low signal power level	dBm	-147

Note: "GPS" here means GPS L1 C/A, Modernized GPS, or both, dependent on UE capabilities.

**Table 6.2.1.2-2: Power level and satellite allocation**

		Satellite allocation for each constellation		
		GNSS-1 <sup>(1)</sup>	GNSS-2	GNSS-3
Single constellation	High signal level	1	-	-
	Low signal level	5	-	-
Dual constellation	High signal level	1	-	-
	Low signal level	2	3	-
Triple constellation	High signal level	1	-	-
	Low signal level	1	2	2

Note: For GPS capable receivers, GNSS-1, i.e. the system having the satellite with high signal level, shall be GPS.

**Table 6.2.1.2-3: Minimum requirements for Sensitivity Coarse Time Assistance**

System	Success rate	2-D position error	Max response time
All	95 %	100 m	20 s

The reference for this requirement is 3GPP TS 25.172 [19], clause 5.1.1.1.

### 6.2.1.3 Test purpose

To verify the UE's first position estimate meets the minimum requirements under GNSS satellite signal conditions that represent weak signal conditions and with only Coarse Time Assistance provided by the SS.

### 6.2.1.4 Method of test

#### 6.2.1.4.1 Initial conditions

Test environment: normal; see Annex G.

1. Connect SS and GSS to the UE antenna connector or antenna connectors as shown in figures A.1 or A.2.
2. Set the GNSS test parameters as specified in table 6.2.1.5-1 for GNSS scenario #1. For GNSS-1, select the first satellite SV ID defined in the relevant table in 3GPP TS 37.571-5 [20] clause 6.2.1.2 for the one satellite with the higher level.
3. Switch on the UE.

#### 6.2.1.4.2 Procedure

1. Start GNSS scenario #1 as specified in 3GPP TS 37.571-5 [20] clause 6.2.1.2 with the UE location randomly selected to be within 3 km of the Reference Location and the altitude of the UE randomly selected between 0 m to 500 m above WGS-84 reference ellipsoid using the method described in 3GPP TS 37.571-5 [20] clause 6.2.1.2.6.
2. Set up a connection using the procedure in clause F.2.
3. Send a RESET UE POSITIONING STORED INFORMATION message followed by RRC MEASUREMENT CONTROL messages containing appropriate assistance data; as specified in 3GPP TS 37.571-5 [20], clauses 6.2.2 and 6.2.7 for UE based testing; or clauses 6.2.4 and 6.2.7 for UE assisted testing with the value of GPS TOW msec or GANSS TOD offset by a random value as specified in 3GPP TS 37.571-5 [20] clause 6.2.7.2; as required to obtain a fix using the procedure specified in 3GPP TS 34.108 [28], clauses 7.5.6 or 7.5.8.
4. If the UE returns a valid result in the MEASUREMENT REPORT message within the Max response time specified in table 6.2.1.5-3 then record the result and process it as specified in step 5. If the UE does not return a valid result within the Max response time specified in table 6.2.1.5-3 or reports a UE positioning error in the MEASUREMENT REPORT message then record one Bad Result.

5. For UE based testing compare the reported position estimate in the MEASUREMENT REPORT message against the simulated position of the UE used in step 1, and calculate the 2D position error as specified in clause 4.5.2.3. Compare the 2D position error against the value in table 6.2.1.5-3 and record one Good Result or Bad Result as appropriate; or

For UE assisted testing convert the GNSS measured results reported in the MEASUREMENT REPORT message to a 2D position using the method described in Annex B and then compare the result against the simulated position of the UE, used in step 1, and calculate the 2D position error as specified in clause 4.5.2.3. Compare the 2D position error against the value in table 6.2.1.5-3 and record one Good Result or Bad Result as appropriate.

6. Release the connection using the procedure in clause F.3.
7. Repeat steps 1 to 6 using GNSS scenario #2 instead of #1 so that the reference location changes sufficiently such that the UE shall have to use the new assistance data. For GNSS-1, select the first satellite SV ID defined in the relevant table in 3GPP TS 37.571-5 [20] clause 6.2.1.2 for the one satellite with the higher level. Use new random values for the UE location and altitude in step 1 and for the GPS TOW msec or GANSS TOD offset in step 3.
8. Repeat steps 1 to 7 until the statistical requirements of clause 6.2.1.5 are met. Each time scenario #1 or #2 is used, the start time of the GNSS scenario shall be advanced by 2 minutes from the time used previously for that scenario. Once a scenario reaches the end of its viable running time, restart it from its nominal start time again. Each time scenario #1 or #2 is used for GNSS-1, select the next satellite SV ID from the one used previously, defined in the relevant table in 3GPP TS 37.571-5 [20] clause 6.2.1.2, for the one satellite with the higher level.

### 6.2.1.5 Test Requirements

For the parameters specified in table 6.2.1.5-1 the UE shall meet the requirements and the success rate specified in table 6.2.1.5-3 with a confidence level of 95% according to Annex D.

**Table 6.2.1.5-1: Test parameters for Sensitivity Coarse Time Assistance**

System	Parameters	Unit	Value
	Number of generated satellites per system	-	See Table 6.2.1.5-2
	Total number of generated satellites	-	6
	HDOP range		1.4 to 2.1
	Propagation conditions	-	AWGN
	GNSS coarse time assistance error range	seconds	$\pm 1.8$
Galileo	Reference high signal power level	dBm	-141
	Reference low signal power level	dBm	-146
GPS <sup>(1)</sup>	Reference high signal power level	dBm	-141
	Reference low signal power level	dBm	-146
GLONASS	Reference high signal power level	dBm	-141
	Reference low signal power level	dBm	-146

Note: "GPS" here means GPS L1 C/A, Modernized GPS, or both, dependent on UE capabilities.

**Table 6.2.1.5-2: Power level and satellite allocation**

		Satellite allocation for each constellation		
		GNSS-1 <sup>(1)</sup>	GNSS-2	GNSS-3
Single constellation	High signal level	1	-	-
	Low signal level	5	-	-
Dual constellation	High signal level	1	-	-
	Low signal level	2	3	-
Triple constellation	High signal level	1	-	-
	Low signal level	1	2	2

Note: For GPS capable receivers, GNSS-1, i.e. the system having the satellite with high signal level, shall be GPS.

**Table 6.2.1.5-3: Test requirements for Sensitivity Coarse Time Assistance**

System	Success rate	2-D position error	Max response time
All	95 %	101.3 m	20.3 s

NOTE: If the above Test Requirement differs from the Minimum Requirement then the Test Tolerance applied for this test is non-zero. The Test Tolerance for this test is defined in clause C.2 and the explanation of how the Minimum Requirement has been relaxed by the Test Tolerance is given in clause C.4.

## 6.2.2 Sensitivity Fine Time Assistance

### 6.2.2.1 Definition and applicability

Sensitivity with fine time assistance is the minimum level of GNSS satellite signals required for the UE to make an A-GNSS position estimate to a specific accuracy and within a specific response time when the network provides fine time assistance in addition to coarse time assistance.

The requirements and this test apply to all types of UTRA for the FDD UE that supports A-GNSS and that is capable of providing an enhanced performance when the network provides Fine Time Assistance.

This test case includes sub-test cases dependent on the GNSS supported by the UE. Each sub-test case is identified by a Sub-Test Case Number as defined in Table 6.2.2.1.

**Table 6.2.2.1: Sub-Test Case Number Definition**

Sub-Test Case Number	Supported GNSS
1	UE supporting A-GLONASS only
2	UE supporting A-Galileo only
3	UE supporting A-GPS and Modernized GPS only
4	UE supporting A-GPS and A-GLONASS only

### 6.2.2.2 Minimum requirements

The first fix position estimates shall meet the accuracy and response time requirements in table 6.2.2.2-3 for the parameters specified in table 6.2.2.2-1.

**Table 6.2.2.2-1: Test parameters for Sensitivity Fine Time Assistance**

System	Parameters	Unit	Value
	Number of generated satellites per system	-	See Table 6.2.2.2-2
	Total number of generated satellites	-	6
	HDOP range		1.4 to 2.1
	Propagation conditions	-	AWGN
	GNSS coarse time assistance error range	seconds	±2
	GNSS fine time assistance error range	µs	±10
Galileo	Reference signal power level	dBm	-147
GPS <sup>(1)</sup>	Reference signal power level	dBm	-147
GLONASS	Reference signal power level	dBm	-147
Note: "GPS" here means GPS L1 C/A, Modernized GPS, or both, dependent on UE capabilities.			

**Table 6.2.2.2-2: Satellite allocation**

	Satellite allocation for each constellation		
	GNSS-1	GNSS-2	GNSS-3
Single constellation	6	-	-
Dual constellation	3	3	-
Triple constellation	2	2	2

**Table 6.2.2.2-3: Minimum requirements for Sensitivity Fine Time Assistance**

System	Success rate	2-D position error	Max response time
All	95 %	100 m	20 s

The reference for this requirement is 3GPP TS 25.172 [19], clause 5.1.2.1.

### 6.2.2.3 Test purpose

To verify the UE's first position estimate meets the minimum requirements under GNSS satellite signal conditions that represent weak signal conditions and with Fine Time Assistance provided by the SS.

### 6.2.2.4 Method of test

#### 6.2.2.4.1 Initial conditions

Test environment: normal; see Annex G.

1. Connect SS and GSS to the UE antenna connector or antenna connectors as shown in figures A.1 or A.2.
2. Set the GNSS test parameters as specified in table 6.2.2.5-1 for GNSS scenario #1.
3. Switch on the UE.

#### 6.2.2.4.2 Procedure

1. Start GNSS scenario #1 as specified in 3GPP TS 37.571-5 [20] clause 6.2.1.2 with the UE location randomly selected to be within 3 km of the Reference Location and the altitude of the UE randomly selected between 0 m to 500 m above WGS-84 reference ellipsoid using the method described in 3GPP TS 37.571-5 [20] clause 6.2.1.2.6.
2. Set up a connection using the procedure in clause F.2.
3. Send a RESET UE POSITIONING STORED INFORMATION message followed by RRC MEASUREMENT CONTROL messages containing appropriate assistance data; as specified in 3GPP TS 37.571-5 [20], clauses 6.2.2 and 6.2.7 for UE based testing; or clauses 6.2.4 and 6.2.7 for UE assisted testing with the values of GPS TOW msec or GANSS TOD, and UTRAN GPS timing of cell frames or UTRAN GANSS timing of cell frames offset by random values as specified in 3GPP TS 37.571-5 [20] clause 6.2.7.2; as required to obtain a fix using the procedure specified in 3GPP TS 34.108 [28], clauses 7.5.6 or 7.5.8.
4. If the UE returns a valid result in the MEASUREMENT REPORT message within the Max response time specified in table 6.2.2.5-3 then record the result and process it as specified in step 5. If the UE does not return a valid result within the Max response time specified in table 6.2.2.5-3 or reports a UE positioning error in the MEASUREMENT REPORT message then record one Bad Result.
5. For UE based testing compare the reported position estimate in the MEASUREMENT REPORT message against the simulated position of the UE used in step 1, and calculate the 2D position error as specified in clause 6.1.1.3. Compare the 2D position error against the value in table 6.2.2.5-3 and record one Good Result or Bad Result as appropriate; or

For UE assisted testing convert the GNSS measured results reported in the MEASUREMENT REPORT message to a 2D position using the method described in Annex B and then compare the result against the



simulated position of the UE used in step 1, and calculate the 2D position error as specified in clause 6.1.1.3. Compare the 2D position error against the value in table 6.2.2.5-3 and record one Good Result or Bad Result as appropriate.

6. Release the connection using the procedure in clause F.3.
7. Repeat steps 1 to 6 using GNSS scenario #2 instead of #1 so that the reference location changes sufficiently such that the UE shall have to use the new assistance data. Use new random values for the UE location and altitude in step 1 and for the GPS TOW msec or GANSS TOD, and UTRAN GPS timing of cell frames or UTRAN GANSS timing of cell frames offsets in step 3.
8. Repeat steps 1 to 7 until the statistical requirements of clause 6.2.2.5 are met. Each time scenario #1 or #2 is used, the start time of the GNSS scenario shall be advanced by 2 minutes from the time used previously for that scenario. Once a scenario reaches the end of its viable running time, restart it from its nominal start time again.

### 6.2.2.5 Test Requirements

For the parameters specified in table 6.2.2.5-1 the UE shall meet the requirements and the success rate specified in table 6.2.2.5-3 with a confidence level of 95% according to Annex D.

**Table 6.2.2.5-1: Test parameters for Sensitivity Fine Time Assistance**

System	Parameters	Unit	Value
	Number of generated satellites per system	-	See Table 6.2.2.5-2
	Total number of generated satellites	-	6
	HDOP range		1.4 to 2.1
	Propagation conditions	-	AWGN
	GNSS coarse time assistance error range	seconds	$\pm 1.8$
	GNSS fine time assistance error range	$\mu\text{s}$	$\pm 9$
Galileo	Reference signal power level	dBm	-146
GPS <sup>(1)</sup>	Reference signal power level	dBm	-146
GLONASS	Reference signal power level	dBm	-146

Note: "GPS" here means GPS L1 C/A, Modernized GPS, or both, dependent on UE capabilities.

**Table 6.2.2.5-2: Satellite allocation**

	Satellite allocation for each constellation		
	GNSS-1	GNSS-2	GNSS-3
Single constellation	6	-	-
Dual constellation	3	3	-
Triple constellation	2	2	2

**Table 6.2.2.5-3: Test requirements for Sensitivity Fine Time Assistance**

System	Success rate	2-D position error	Max response time
All	95 %	101.3 m	20.3 s

NOTE: If the above Test Requirement differs from the Minimum Requirement then the Test Tolerance applied for this test is non-zero. The Test Tolerance for this test is defined in clause C.2 and the explanation of how the Minimum Requirement has been relaxed by the Test Tolerance is given in clause C.4.

## 6.3 Nominal Accuracy

### 6.3.1 Definition and applicability

Nominal accuracy is the accuracy of the UE's A-GNSS position estimate under ideal GNSS signal conditions.

The requirements and this test apply to all types of UTRA for the FDD UE that supports A-GNSS.

This test case includes sub-test cases dependent on the GNSS supported by the UE. Each sub-test case is identified by a Sub-Test Case Number as defined in Table 6.3.1.

**Table 6.3.1: Sub-Test Case Number Definition**

Sub-Test Case Number	Supported GNSS
1	UE supporting A-GLONASS only
2	UE supporting A-Galileo only
3	UE supporting A-GPS and Modernized GPS only
4	UE supporting A-GPS and A-GLONASS only

## 6.3.2 Minimum requirements

The first fix position estimates shall meet the accuracy and response time requirements in table 6.3.2-3 for the parameters specified in table 6.3.2-1.

**Table 6.3.2-1: Test parameters for Nominal Accuracy**

System	Parameters	Unit	Value
	Number of generated satellites per system	-	See Table 6.3.2-2
	Total number of generated satellites	-	6 or 7 <sup>(2)</sup>
	HDOP Range	-	1.4 to 2.1
	Propagation conditions	-	AWGN
	GNSS coarse time assistance error range	seconds	±2
GPS <sup>(1)</sup>	Reference signal power level for all satellites	dBm	-128.5
Galileo	Reference signal power level for all satellites	dBm	-127
GLONASS	Reference signal power level for all satellites	dBm	-131
QZSS	Reference signal power level for all satellites	dBm	-128.5
SBAS	Reference signal power level for all satellites	dBm	-131
Note 1: "GPS" here means GPS L1 C/A, Modernized GPS, or both, dependent on UE capabilities.			
Note 2: 7 satellites apply only for SBAS case.			

If QZSS is supported, one of the GPS satellites will be replaced by a QZSS satellite with respective signal support.

If SBAS is supported, the SBAS satellite with the highest elevation will be added to the scenario.

**Table 6.3.2-2: Satellite allocation**

	Satellite allocation for each constellation			
	GNSS 1 <sup>(1)</sup>	GNSS 2 <sup>(1)</sup>	GNSS 3 <sup>(1)</sup>	SBAS
Single constellation	6	--	--	1
Dual constellation	3	3	--	1
Triple constellation	2	2	2	1
Note: GNSS refers to global systems i.e., GPS, Galileo, GLONASS.				

**Table 6.3.2-3: Minimum requirements for Nominal Accuracy**

System	Success rate	2-D position error	Max response time
All	95 %	15 m	20 s

The reference for this requirement is 3GPP TS 25.172 [19], clause 5.2.1.

## 6.3.3 Test purpose

To verify the UE's first position estimate meets the minimum requirements under GNSS satellite signal conditions that represent ideal conditions.

## 6.3.4 Method of test

### 6.3.4.1 Initial conditions

Test environment: normal; see Annex G.

1. Connect SS and GSS to the UE antenna connector or antenna connectors as shown in figures A.1 or A.2.
2. Set the GNSS test parameters as specified in table 6.3.4.2 for GNSS scenario #3.
3. Switch on the UE.

### 6.3.4.2 Procedure

1. Start GNSS scenario #3 as specified in 3GPP TS 37.571-5 [20] clause 6.2.1.2 with the UE location randomly selected to be within 3 km of the Reference Location and the altitude of the UE randomly selected between 0 m to 500 m above WGS-84 reference ellipsoid using the method described in 3GPP TS 37.571-5 [20] clause 6.2.1.2.6.
2. Set up a connection using the procedure in clause F.2.
3. Send a RESET UE POSITIONING STORED INFORMATION message followed by RRC MEASUREMENT CONTROL messages containing appropriate assistance data; as specified in 3GPP TS 37.571-5 [20], clauses 6.2.2 and 6.2.7 for UE based testing; or clauses 6.2.4 and 6.2.7 for UE assisted testing with the value of GPS TOW msec or GANSS TOD offset by a random value as specified in 3GPP TS 37.571-5 [20] clause 6.2.7.2; using the exception to the RRC MEASUREMENT CONTROL message listed in table 6.3.5-1; as required to obtain a fix using the procedure specified in 3GPP TS 34.108 [28], clauses 7.5.6 or 7.5.8.

**Table 6.3.4.2: Contents of RRC MEASUREMENT CONTROL message**

Information Element	Value/Remark
- UE positioning reporting quantity - Horizontal accuracy	'6' (7.7m)

4. If the UE returns a valid result in the MEASUREMENT REPORT message within the Max response time specified in table 6.3.5-3 then record the result and process it as specified in step 5. If the UE does not return a valid result within the Max response time specified in table 6.3.5-3 or reports a UE positioning error in the MEASUREMENT REPORT message then record one Bad Result.
5. For UE based testing compare the reported position estimate in the MEASUREMENT REPORT message against the simulated position of the UE used in step 1, and calculate the 2D position error as specified in clause 6.1.1.3. Compare the 2D position error against the value in table 6.3.5-3 and record one Good Result or Bad Result as appropriate; or  
  
For UE assisted testing convert the GNSS measured results reported in the MEASUREMENT REPORT message to a 2D position using the method described in Annex B and then compare the result against the simulated position of the UE used in step 1, and calculate the 2D position error as specified in clause 6.1.1.3. Compare the 2D position error against the value in table 6.3.5-3 and record one Good Result or Bad Result as appropriate.
6. Release the connection using the procedure in clause F.3.
7. Repeat steps 1 to 6 using GNSS scenario #4 instead of #3 so that the reference location changes sufficiently such that the UE shall have to use the new assistance data. Use new random values for the UE location and altitude in step 1 and for the GPS TOW msec or GANSS TOD offset in step 3.
8. Repeat steps 1 to 7 until the statistical requirements of clause 6.3.5 are met. Each time scenario #3 or #4 is used, the start time of the GNSS scenario shall be advanced by 2 minutes from the time used previously for that scenario. Once a scenario reaches the end of its viable running time, restart it from its nominal start time again.

## 6.3.5 Test Requirements

For the parameters specified in table 6.3.5-1 the UE shall meet the requirements and the success rate specified in table 6.3.5-3 with a confidence level of 95% according to Annex D.

**Table 6.3.5-1: Test parameters for Nominal Accuracy**

System	Parameters	Unit	Value
	Number of generated satellites per system	-	See Table 6.3.5-3
	Total number of generated satellites	-	6 or 7 <sup>(2)</sup>
	HDOP Range	-	1.4 to 2.1
	Propagation conditions	-	AWGN
	GNSS coarse time assistance error range	seconds	±1.8
GPS <sup>(1)</sup>	Reference signal power level for all satellites	dBm	-128.5
Galileo	Reference signal power level for all satellites	dBm	-127
GLONASS	Reference signal power level for all satellites	dBm	-131
QZSS	Reference signal power level for all satellites	dBm	-128.5
SBAS	Reference signal power level for all satellites	dBm	-131
Note 1: "GPS" here means GPS L1 C/A, Modernized GPS, or both, dependent on UE capabilities.			
Note 2: 7 satellites apply only for SBAS case.			

If QZSS is supported, one of the GPS satellites will be replaced by a QZSS satellite with respective signal support.

If SBAS is supported, the SBAS satellite with the highest elevation will be added to the scenario.

**Table 6.3.5-2: Satellite allocation**

	Satellite allocation for each constellation			
	GNSS 1 <sup>(1)</sup>	GNSS 2 <sup>(1)</sup>	GNSS 3 <sup>(1)</sup>	SBAS
Single constellation	6	--	--	1
Dual constellation	3	3	--	1
Triple constellation	2	2	2	1
Note: GNSS refers to global systems i.e., GPS, Galileo, GLONASS.				

**Table 6.3.5-3: Test requirements for Nominal Accuracy**

System	Success rate	2-D position error	Max response time
All	95 %	16.3 m	20.3 s

NOTE: If the above Test Requirement differs from the Minimum Requirement then the Test Tolerance applied for this test is non-zero. The Test Tolerance for this test is defined in clause C.2 and the explanation of how the Minimum Requirement has been relaxed by the Test Tolerance is given in clause C.4.

## 6.4 Dynamic Range

### 6.4.1 Definition and applicability

Dynamic Range is the maximum difference in level of the GNSS signals from a number of satellites that allows the UE to make an A-GNSS position estimate with a specific accuracy and a specific response time.

The requirements and this test apply to all types of UTRA for the FDD UE that supports A-GNSS.

This test case includes sub-test cases dependent on the GNSS supported by the UE. Each sub-test case is identified by a Sub-Test Case Number as defined in Table 6.4.1.

**Table 6.4.1: Sub-Test Case Number Definition**

Sub-Test Case Number	Supported GNSS
1	UE supporting A-GLONASS only
2	UE supporting A-Galileo only
3	UE supporting A-GPS and Modernized GPS only
4	UE supporting A-GPS and A-GLONASS only

## 6.4.2 Minimum requirements

The first fix position estimates shall meet the accuracy and response time requirements in table 6.4.2-3 for the parameters specified in table 6.4.2-1.

**Table 6.4.2-1: Test parameters for Dynamic Range**

System	Parameters	Unit	Value
	Number of generated satellites per system	-	See Table 6.4.2-2
	Total number of generated satellites	-	6
	HDOP Range	-	1.4 to 2.1
	Propagation conditions	-	AWGN
	GNSS coarse time assistance error range	seconds	±2
Galileo	Reference high signal power level	dBm	-127.5
	Reference low signal power level	dBm	-147
GPS <sup>(1)</sup>	Reference high signal power level	dBm	-129
	Reference low signal power level	dBm	-147
GLONASS	Reference high signal power level	dBm	-131.5
	Reference low signal power level	dBm	-147

Note: "GPS" here means GPS L1 C/A, Modernized GPS, or both, dependent on UE capabilities.

**Table 6.4.2-2: Power level and satellite allocation**

		Satellite allocation for each constellation		
		GNSS 1 <sup>(1)</sup>	GNSS 2 <sup>(1)</sup>	GNSS 3 <sup>(1)</sup>
Single constellation	High signal level	2	--	--
	Low signal level	4	--	--
Dual constellation	High signal level	1	1	--
	Low signal level	2	2	--
Triple constellation	High signal level	1	1	1
	Low signal level	1	1	1

Note: GNSS refers to global systems i.e., GPS, Galileo, GLONASS.

**Table 6.4.2-3: Minimum requirements for Dynamic Range**

System	Success rate	2-D position error	Max response time
All	95 %	100 m	20 s

The reference for this requirement is 3GPP TS 25.172 [19], clause 5.3.1.

## 6.4.3 Test purpose

To verify the UE's first position estimate meets the minimum requirements under GNSS satellite signal conditions that have a wide dynamic range. Strong satellites are likely to degrade the acquisition of weaker satellites due to their cross-correlation products.

## 6.4.4 Method of test

### 6.4.4.1 Initial conditions

Test environment: normal; see Annex G.

1. Connect SS and GSS to the UE antenna connector or antenna connectors as shown in figures A.1 or A.2.
2. Set the GNSS test parameters as specified in table 6.4.5-1 for GNSS scenario #1. Randomly select from the satellite SV IDs defined in the table in 3GPP TS 37.571-5 [20] clause 6.2.1.2 for the satellites with the higher levels.
3. Switch on the UE.

### 6.4.4.2 Procedure

1. Start GNSS scenario #1 as specified in 3GPP TS 37.571-5 [20] clause 6.2.1.2 with the UE location randomly selected to be within 3 km of the Reference Location and the altitude of the UE randomly selected between 0 m to 500 m above WGS-84 reference ellipsoid using the method described in 3GPP TS 37.571-5 [20] clause 6.2.1.2.6.
2. Set up a connection using the procedure in clause F.2.
3. Send a RESET UE POSITIONING STORED INFORMATION message followed by RRC MEASUREMENT CONTROL messages containing appropriate assistance data; as specified in 3GPP TS 37.571-5 [20], clauses 6.2.2 and 6.2.7 for UE based testing; or clauses 6.2.4 and 6.2.7 for UE assisted testing with the value of GPS TOW msec or GANSS TOD offset by a random value as specified in 3GPP TS 37.571-5 [20] clause 6.2.7.2; as required to obtain a fix using the procedure specified in 3GPP TS 34.108 [28], clauses 7.5.6 or 7.5.8.
4. If the UE returns a valid result in the MEASUREMENT REPORT message within the Max response time specified in table 6.4.5-3 then record the result and process it as specified in step 5. If the UE does not return a valid result within the Max response time specified in table 6.4.5-3 or reports a UE positioning error in the MEASUREMENT REPORT message then record one Bad Result.
5. For UE based testing compare the reported position estimate in the MEASUREMENT REPORT message against the simulated position of the UE used in step 1, and calculate the 2D position error as specified in clause 6.1.1.3. Compare the 2D position error against the value in table 6.4.5-3 and record one Good Result or Bad Result as appropriate; or

For UE assisted testing convert the GNSS measured results reported in the MEASUREMENT REPORT message to a 2D position using the method described in Annex B and then compare the result against the simulated position of the UE used in step 1, and calculate the 2D position error as specified in clause 6.1.1.3. Compare the 2D position error against the value in table 6.4.5-3 and record one Good Result or Bad Result as appropriate.

6. Release the connection using the procedure in clause F.3.
7. Repeat steps 1 to 6 using GNSS scenario #2 instead of #1 so that the reference location changes sufficiently such that the UE shall have to use the new assistance data. Randomly select from the satellite SV IDs defined in the table in 3GPP TS 37.571-5 [20] clause 6.2.1.2 for the satellites with the higher levels. Use new random values for the UE location and altitude in step 1 and for the GPS TOW msec or GANSS TOD offset in step 3.
8. Repeat steps 1 to 7 until the statistical requirements of clause 6.4.5 are met. Each time scenario #1 or #2 is used, the start time of the GNSS scenario shall be advanced by 2 minutes from the time used previously for that scenario. Once a scenario reaches the end of its viable running time, restart it from its nominal start time again. Each time scenario #1 or #2 is used, randomly select from the set of satellite SV IDs defined in the table in 3GPP TS 37.571-5 [20] clause 6.2.1.2, for the satellites with the higher levels.

## 6.4.5 Test Requirements

For the parameters specified in table 6.4.5-1 the UE shall meet the requirements and the success rate specified in table 6.4.5-3 with a confidence level of 95% according to Annex D.

**Table 6.4.5-1: Test parameters for Dynamic Range**

System	Parameters	Unit	Value
	Number of generated satellites per system	-	See Table 6.4.5-2
	Total number of generated satellites	-	6
	HDOP Range	-	1.4 to 2.1
	Propagation conditions	-	AWGN
	GNSS coarse time assistance error range	seconds	±2
Galileo	Reference high signal power level	dBm	-126.7
	Reference low signal power level	dBm	-146
GPS <sup>(1)</sup>	Reference high signal power level	dBm	-128.2
	Reference low signal power level	dBm	-146
GLONASS	Reference high signal power level	dBm	-130.7
	Reference low signal power level	dBm	-146
Note: "GPS" here means GPS L1 C/A, Modernized GPS, or both, dependent on UE capabilities.			

**Table 6.4.5-2: Power level and satellite allocation**

		Satellite allocation for each constellation		
		GNSS 1 <sup>(1)</sup>	GNSS 2 <sup>(1)</sup>	GNSS 3 <sup>(1)</sup>
Single constellation	High signal level	2	--	--
	Low signal level	4	--	--
Dual constellation	High signal level	1	1	--
	Low signal level	2	2	--
Triple constellation	High signal level	1	1	1
	Low signal level	1	1	1
Note: GNSS refers to global systems i.e., GPS, Galileo, GLONASS.				

**Table 6.4.5-3: Test requirements for Dynamic Range**

System	Success rate	2-D position error	Max response time
All	95 %	101.3 m	20.3 s

NOTE: If the above Test Requirement differs from the Minimum Requirement then the Test Tolerance applied for this test is non-zero. The Test Tolerance for this test is defined in clause C.2 and the explanation of how the Minimum Requirement has been relaxed by the Test Tolerance is given in clause C.4.

## 6.5 Multi-path Performance

### 6.5.1 Definition and applicability

Multi-path performance measures the accuracy and response time of the UE's A-GNSS position estimate in a specific GNSS signal multi-path environment.

The requirements and this test apply to all types of UTRA for the FDD UE that supports A-GNSS.

This test case includes sub-test cases dependent on the GNSS supported by the UE. Each sub-test case is identified by a Sub-Test Case Number as defined in Table 6.5.1.

**Table 6.5.1: Sub-Test Case Number Definition**

Sub-Test Case Number	Supported GNSS
1	UE supporting A-GLONASS only
2	UE supporting A-Galileo only
3	UE supporting A-GPS and Modernized GPS only
4	UE supporting A-GPS and A-GLONASS only

## 6.5.2 Minimum requirements

The first fix position estimates shall meet the accuracy and response time requirements in table 6.5.2-3 for the parameters specified in table 6.5.2-1.

**Table 6.5.2-1: Test parameters for Multi-path Performance**

System	Parameters	Unit	Value
	Number of generated satellites per system	-	See Table 6.5.2-2
	Total number of generated satellites	-	6
	HDOP range		1.4 to 2.1
	Propagation conditions	-	AWGN
	GNSS coarse time assistance error range	seconds	±2
Galileo	Reference signal power level	dBm	-127
GPS <sup>(1)</sup>	Reference signal power level	dBm	-128.5
GLONASS	Reference signal power level	dBm	-131
Note: "GPS" here means GPS L1 C/A, Modernized GPS, or both, dependent on UE capabilities.			

**Table 6.5.2-2: Channel model allocation**

		Channel model allocation for each constellation		
		GNSS-1	GNSS-2	GNSS-3
Single constellation	One-tap channel	2	--	--
	Two-tap channel	4	--	--
Dual constellation	One-tap channel	1	1	--
	Two-tap channel	2	2	--
Triple constellation	One-tap channel	1	1	1
	Two-tap channel	1	1	1
Note: One-tap channel: no multi-path. Two-tap channel: multi-path defined in clause 4.2.4				

**Table 6.5.2-3: Minimum requirements for Multi-path Performance**

System	Success rate	2-D position error	Max response time
All	95 %	100 m	20 s

The reference for this requirement is 3GPP TS 25.172 [19], clause 5.4.1.

## 6.5.3 Test purpose

To verify the UE's first position estimate meets the minimum requirements under GNSS satellite signal conditions that represent simple multi-path conditions.

## 6.5.4 Method of test

### 6.5.4.1 Initial conditions

Test environment: normal; see Annex G.

1. Connect SS and GSS to the UE antenna connector or antenna connectors as shown in figures A.1 or A.2.
2. Set the GNSS test parameters as specified in table 6.5.5-1 for GNSS scenario #1. Randomly select from the satellite SV IDs defined in the table in 3GPP TS 37.571-5 [20] clause 6.2.1.2 for the satellites with one-tap channel.
3. Switch on the UE.



## 6.5.4.2 Procedure

1. Start GNSS scenario #1 as specified in 3GPP TS 37.571-5 [20] clause 6.2.1.2 with the UE location randomly selected to be within 3 km of the Reference Location and the altitude of the UE randomly selected between 0 m to 500 m above WGS-84 reference ellipsoid using the method described in 3GPP TS 37.571-5 [20] clause 6.2.1.2.6. The initial carrier phase difference between taps of the multi-path model shall be randomly selected between 0 and  $2\pi$  radians by selecting the next random number from a standard uniform random number generator, in the range 0 to  $2\pi$ , representing radians with a resolution of 0.1, representing 0.1 radians.
2. Set up a connection using the procedure in clause F.2.
3. Send a RESET UE POSITIONING STORED INFORMATION message followed by RRC MEASUREMENT CONTROL messages containing appropriate assistance data; as specified in 3GPP TS 37.571-5 [20], clauses 6.2.2 and 6.2.7 for UE based testing; or clauses 6.2.4 and 6.2.7 for UE assisted testing with the value of GPS TOW msec or GANSS TOD offset by a random value as specified in 3GPP TS 37.571-5 [20] clause 6.2.7.2; as required to obtain a fix using the procedure specified in 3GPP TS 34.108 [28], clauses 7.5.6 or 7.5.8.
4. If the UE returns a valid result in the MEASUREMENT REPORT message within the Max response time specified in table 6.5.5-4 then record the result and process it as specified in step 5. If the UE does not return a valid result within the Max response time specified in table 6.5.5-4 or reports a UE positioning error in the MEASUREMENT REPORT message then record one Bad Result.
5. For UE based testing compare the reported position estimate in the MEASUREMENT REPORT message against the simulated position of the UE used in step 1, and calculate the 2D position error as specified in clause 6.1.1.3. Compare the 2D position error against the value in table 6.5.5-4 and record one Good Result or Bad Result as appropriate; or  
  
For UE assisted testing convert the GNSS measured results reported in the MEASUREMENT REPORT message to a 2D position using the method described in Annex B and then compare the result against the simulated position of the UE used in step 1, and calculate the 2D position error as specified in clause 6.1.1.3. Compare the 2D position error against the value in table 6.5.5-4 and record one Good Result or Bad Result as appropriate.
6. Release the connection using the procedure in clause F.3.
7. Repeat steps 1 to 6 using GNSS scenario #2 instead of #1 so that the reference location changes sufficiently such that the UE shall have to use the new assistance data. Randomly select from the satellite SV IDs defined in the table in 3GPP TS 37.571-5 [20] clause 6.2.1.2 for the satellites with one-tap channel. Use new random values for the UE location and altitude, and the initial carrier phase difference between taps of the multi-path model in step 1 and for the GPS TOW msec or GANSS TOD offset in step 3.
8. Repeat steps 1 to 7 until the statistical requirements of clause 6.5.5 are met. Each time scenario #1 or #2 is used, the start time of the GNSS scenario shall be advanced by 2 minutes from the time used previously for that scenario. Once a scenario reaches the end of its viable running time, restart it from its nominal start time again. Each time scenario #1 or #2 is used, randomly select from the satellite SV IDs defined in the table in 3GPP TS 37.571-5 [20] clause 6.2.1.2, for the satellites with one-tap channel.

## 6.5.5 Test Requirements

For the parameters specified in table 6.5.5-1 the UE shall meet the requirements and the success rate specified in table 6.5.5-4 with a confidence level of 95% according to Annex D.

**Table 6.5.5-1: Test parameters for Multi-path Performance**

System	Parameters	Unit	Value
	Number of generated satellites per system	-	See Table 6.5.5-1
	Total number of generated satellites	-	6
	HDOP range		1.4 to 2.1
	Propagation conditions	-	AWGN
	GNSS coarse time assistance error range	seconds	±1.8
Galileo	Reference signal power level	dBm	-127
GPS <sup>(1)</sup>	Reference signal power level	dBm	-128.5
GLONASS	Reference signal power level	dBm	-131
Note: "GPS" here means GPS L1 C/A, Modernized GPS, or both, dependent on UE capabilities.			

**Table 6.5.5-2: Channel model allocation**

		Channel model allocation for each constellation		
		GNSS-1	GNSS-2	GNSS-3
Single constellation	One-tap channel	2	--	--
	Two-tap channel	4	--	--
Dual constellation	One-tap channel	1	1	--
	Two-tap channel	2	2	--
Triple constellation	One-tap channel	1	1	1
	Two-tap channel	1	1	1
Note: One-tap channel: no multi-path. Two-tap channel: multi-path defined in clause 4.2.4 with Relative mean Power (Y) defined in Table 6.5.7.				

**Table 6.5.5-3: Relative mean Power (Y) for use in Table 6.5.6**

System	Signals	Y [dB]
Galileo	E1	-4.7
	E5a	-6.2
	E5b	-6.2
GPS/Modernized GPS	L1 C/A	-6.2
	L1C	-4.7
	L2C	-6.2
GLONASS	L5	-6.2
	G1	-12.7
	G2	-12.7

**Table 6.5.5-4: Test requirements for Multi-path Performance**

System	Success rate	2-D position error	Max response time
All	95 %	101.3 m	20.3 s

NOTE: If the above Test Requirement differs from the Minimum Requirement then the Test Tolerance applied for this test is non-zero. The Test Tolerance for this test is defined in clause C.2 and the explanation of how the Minimum Requirement has been relaxed by the Test Tolerance is given in clause C.4.

## 6.6 Moving Scenario and Periodic Update Performance

### 6.6.1 Definition and applicability

Moving scenario and periodic update performance measures the accuracy of the UE's A-GNSS position estimates and the periodic update capability of the UE in a moving scenario.

The requirements and this test apply to all types of UTRA for the FDD UE that supports A-GNSS.

This test case includes sub-test cases dependent on the GNSS supported by the UE. Each sub-test case is identified by a Sub-Test Case Number as defined in Table 6.6.1.

**Table 6.6.1: Sub-Test Case Number Definition**

Sub-Test Case Number	Supported GNSS
1	UE supporting A-GLONASS only
2	UE supporting A-Galileo only
3	UE supporting A-GPS and Modernized GPS only
4	UE supporting A-GPS and A-GLONASS only

## 6.6.2 Minimum requirements

The position estimates, after the first reported position estimate, shall meet the accuracy requirement in table 6.6.2-3 with the periodical reporting interval of 2 seconds for the parameters specified in table 6.6.2-1.

NOTE: In the actual testing the UE may report error messages until it has been able to acquire GNSS measured results or a position estimate. The SS shall only consider the first measurement report different from an error message as the first position estimate in the requirement in table 6.6.2-1.

**Table 6.6.2-1: Test parameters for Moving Scenario and Periodic Update Performance**

System	Parameters	Unit	Value
	Number of generated satellites per system	-	See Table 6.6.2-2
	Total number of generated satellites	-	6
	HDOP Range per system	-	1.4 to 2.1
	Propagation conditions	-	AWGN
	GNSS coarse time assistance error range	seconds	±2
Galileo	Reference signal power level for all satellites	dBm	-127
GPS <sup>(1)</sup>	Reference signal power level for all satellites	dBm	-128.5
GLONASS	Reference signal power level for all satellites	dBm	-131
Note: "GPS" here means GPS L1 C/A, Modernized GPS, or both, dependent on UE capabilities.			

**Table 6.6.2-2: Satellite allocation**

	Satellite allocation for each constellation		
	GNSS 1 <sup>(1)</sup>	GNSS 2 <sup>(1)</sup>	GNSS 3 <sup>(1)</sup>
Single constellation	6	--	--
Dual constellation	3	3	--
Triple constellation	2	2	2
Note: GNSS refers to global systems i.e., GPS, Galileo, GLONASS.			

**Table 6.6.2-3: Minimum requirements for Moving Scenario and Periodic Update Performance**

System	Success rate	2-D position error	Periodical reporting interval
All	95 %	50 m	2 s

The reference for this requirement is 3GPP TS 25.172 [19], clause 5.5.1.

## 6.6.3 Test purpose

To verify the UE's position estimates, after the first reported position estimate, meet the minimum requirements under GNSS satellite signal conditions that simulate a moving scenario. A good tracking performance, with regular position estimate reporting is essential for certain location services.

## 6.6.4 Method of test

### 6.6.4.1 Initial conditions

Test environment: normal; see Annex G.

The UE is requested to use periodical reporting with a reporting interval of 2 seconds.

The GNSS signals simulate the UE moving on a rectangular trajectory of 940 m by 1 440 m with rounded corners defined in figure 6.6.1 and table 6.6.4.1. The initial reference is first defined followed by acceleration to final speed of 100 km/h in 250 m. The UE then maintains the speed for 400 m. This is followed by deceleration to final speed of 25 km/h in 250 m. The UE then turn 90 degrees with turning radius of 20 m at 25 km/h. This is followed by acceleration to final speed of 100 km/h in 250 m. The sequence is repeated to complete the rectangle.

**Table 6.6.4.1: Trajectory Parameters for Moving Scenario and Periodic Update Performance test case**

Parameter	Distance (m)	Speed (km/h)
$l_{11}, l_{15}, l_{21}, l_{25}$	20	25
$l_{12}, l_{14}, l_{22}, l_{24}$	250	25 to 100 and 100 to 25
$l_{13}$	400	100
$l_{23}$	900	100

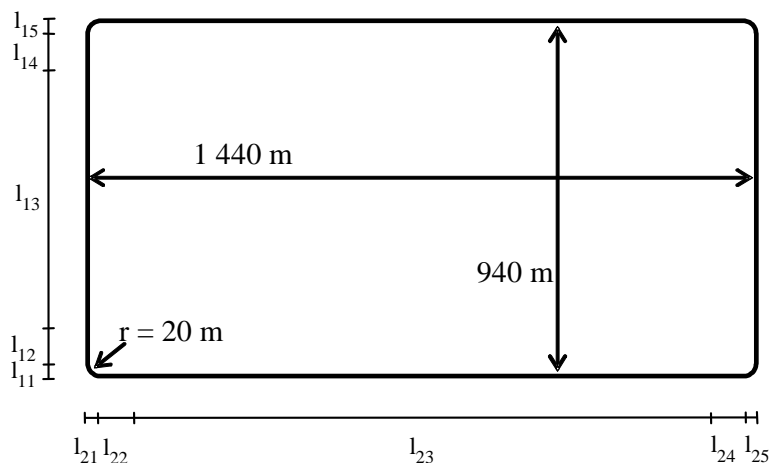

**Figure 6.6.1: Rectangular Trajectory for Moving Scenario and Periodic Update Performance test case**

1. Connect SS and GSS to the UE antenna connector or antenna connectors as shown in figures A.1 or A.2.
2. Set the GNSS test parameters as specified in table 6.6.5-1 for GNSS scenario #5.
3. Switch on the UE.
4. Set up a connection using the procedure in clause F.2.

### 6.6.4.2 Procedure

1. Start GNSS scenario #5 as specified in 3GPP TS 37.571-5 [20], clause 6.2.1.2.
2. Send a RESET UE POSITIONING STORED INFORMATION message followed by RRC MEASUREMENT CONTROL messages containing appropriate assistance data; as specified in 3GPP TS 37.571-5 [20], clauses 6.2.2 and 6.2.7 for UE based testing; or clauses 6.2.4 and 6.2.7 for UE assisted testing; using the exception to the RRC MEASUREMENT CONTROL message listed in table 6.6.4.2; as required to obtain fixes using the procedure specified in 3GPP TS 34.108 [28], clauses 7.5.7 or 7.5.9.

**Table 6.6.4.2: Contents of RRC MEASUREMENT CONTROL message**

Information Element	Value/Remark
- UE positioning reporting quantity - Horizontal accuracy	'13' (24.5m)

3. Ignore any error messages that the UE may report in MEASUREMENT REPORT messages until it has been able to acquire the GNSS signals and reports the first GNSS measured result or position estimate.
4. Discard the first GNSS measured result or position estimate.
5. Record the time of reception of the next MEASUREMENT REPORT message after reception of the first GNSS measured result or position estimate.
6. After the reception of the first GNSS measured result or position estimate reported in a MEASUREMENT REPORT message, every time the UE returns a GNSS measured result or position estimate in the MEASUREMENT REPORT message record the time of reception and the result. If the difference between the time of reception and the time of reception of the previous result is less than 1.5 seconds or greater than 2.5 seconds, or if the UE reports a UE positioning error in any MEASUREMENT REPORT messages, then record one Bad Result. Otherwise process the result as specified in step 7.
7. For UE based testing compare the reported position estimate in the MEASUREMENT REPORT message against the simulated position of the UE at the time of applicability reported in the position estimate and calculate the 2D position error as specified in clause 6.1.1.3. Compare the 2D position error against the value in table 6.6.9 and record one Good Result or Bad Result as appropriate; or

For UE assisted testing convert the GNSS measured results reported in the MEASUREMENT REPORT message to a 2D position using the method described in Annex B and then compare the result against the simulated position of the UE at the time of applicability reported in the GNSS measured results and calculate the 2D position error as specified in clause 6.1.1.3. Compare the 2D position error against the value in table 6.6.9 and record one Good Result or Bad Result as appropriate.

8. If the UE sends the first MEASUREMENT REPORT that contains a measured result or position estimate later than 240s after the start of the GNSS scenario, fail the UE and stop the test early. Otherwise collect MEASUREMENT REPORTs during 900s, starting from the time recorded in step 5. If at any time the difference between the times of reception of two consecutive results is greater than 240s, fail the UE and stop the test early. Use the collected Good Results and Bad Results to determine the PASS/FAIL according to clause 6.6.5.
9. Release the connection using the procedure in clause F.3.

## 6.6.5 Test Requirements

For the parameters specified in table 6.6.5-1, after the first reported position estimate, the UE shall meet the accuracy requirement and the success rate specified in table 6.6.5-3 with a periodical reporting interval of 2 seconds +/- 20% plus measurement system uncertainty of 100ms.

NOTE: Due to the statistical nature of the results it is not possible to design a test with predefined confidence level for the success rate in Table 6.6.5-3; therefore a simple PASS/FAIL of the results gathered against this success rate is used.

**Table 6.6.5-1: Test parameters for Moving Scenario and Periodic Update Performance**

System	Parameters	Unit	Value
	Number of generated satellites per system	-	See Table 6.6.5-2
	Total number of generated satellites	-	6
	HDOP Range per system	-	1.4 to 2.1
	Propagation conditions	-	AWGN
	GNSS coarse time assistance error range	seconds	±1.8
Galileo	Reference signal power level for all satellites	dBm	-127
GPS <sup>(1)</sup>	Reference signal power level for all satellites	dBm	-128.5
GLONASS	Reference signal power level for all satellites	dBm	-131
Note: "GPS" here means GPS L1 C/A, Modernized GPS, or both, dependent on UE capabilities.			

**Table 6.6.5-2: Satellite allocation**

	Satellite allocation for each constellation		
	GNSS 1 <sup>(1)</sup>	GNSS 2 <sup>(1)</sup>	GNSS 3 <sup>(1)</sup>
Single constellation	6	--	--
Dual constellation	3	3	--
Triple constellation	2	2	2
Note: GNSS refers to global systems i.e., GPS, Galileo, GLONASS.			

**Table 6.6.5-3: Test requirements for Moving Scenario and Periodic Update Performance**

System	Success rate	2-D position error
All	95 %	51.3 m

NOTE 1: If the above Test Requirement differs from the Minimum Requirement then the Test Tolerance applied for this test is non-zero. The Test Tolerance for this test is defined in clause C.2 and the explanation of how the Minimum Requirement has been relaxed by the Test Tolerance is given in clause C.4.

NOTE 2: In the actual testing the UE may report error messages until it has been able to acquire GNSS measured results or a position estimate. The test equipment shall only consider the first measurement report different from an error message as the first position estimate in the requirement in table 6.6.5-3.

## 7 E-UTRA A-GNSS minimum performance requirements

### 7.1 Sensitivity

#### 7.1.1 Sensitivity Coarse time assistance

##### 7.1.1.1 Sub-tests

This test includes sub-tests dependent on the GNSS supported by the UE. Each sub-test is identified by a Sub-Test Number as defined in Table 7.1.1.1

**Table 7.1.1.1: Sub-Test Number Definition**

Sub-Test Number	Supported GNSS
1	UE supporting A-GPS L1C/A only
2	UE supporting A-GLONASS only
3	UE supporting A-Galileo only
4	UE supporting A-GPS and Modernized GPS only
5	UE supporting A-GPS and A-GLONASS only

##### 7.1.1.2 Test purpose

To verify the performance of the first position estimate, when the UE is provided with only coarse time assistance.

##### 7.1.1.3 Test applicability

This test applies to all types of E-UTRA UE release 9 and forward that supports A-GNSS.

##### 7.1.1.4 Minimum conformance requirements

The first fix position estimates shall meet the accuracy and response time requirements in table 7.1.1.2 for the parameters specified in table 7.1.1.3 or 7.1.1.4.

**Table 7.1.1.2: Requirements Sensitivity Coarse time assistance**

Success rate	2-D position error	Max response time
95 %	100 m	20 s

**Table 7.1.1.3: Parameters Sensitivity Coarse time assistance - Sub-Test 1**

Parameters	Unit	Value
Number of generated satellites	-	8
HDOP Range	-	1.1 to 1.6
Propagation conditions	-	AWGN
GPS Coarse time assistance error range	seconds	±2
GPS L1 C/A Signal for one satellites	dBm	-142
GPS L1 C/A Signal for remaining satellites	dBm	-147

**Table 7.1.1.4: Parameters Sensitivity Coarse time assistance - Sub-Tests 2 to 5**

System	Parameters	Unit	Value
	Number of generated satellites per system	-	See Table 7.1.1.5
	Total number of generated satellites	-	6
	HDOP range		1.4 to 2.1
	Propagation conditions	-	AWGN
	GNSS coarse time assistance error range	seconds	±2
Galileo	Reference high signal power level	dBm	-142
	Reference low signal power level	dBm	-147
GPS <sup>(1)</sup>	Reference high signal power level	dBm	-142
	Reference low signal power level	dBm	-147
GLONASS	Reference high signal power level	dBm	-142
	Reference low signal power level	dBm	-147
NOTE 1: "GPS" here means GPS L1 C/A, Modernized GPS, or both, dependent on UE capabilities.			

**Table 7.1.1.5: Power level and satellite allocation**

		Satellite allocation for each constellation		
		GNSS-1 <sup>(1)</sup>	GNSS-2	GNSS-3
Single constellation	High signal level	1	-	-
	Low signal level	5	-	-
Dual constellation	High signal level	1	-	-
	Low signal level	2	3	-
Triple constellation	High signal level	1	-	-
	Low signal level	1	2	2
Note 1: For GPS capable receivers, GNSS-1, i.e. the system having the satellite with high signal level, shall be GPS.				

The normative reference for this requirement is TS 36.171 [3] clause 5.1.1 and 6.1.1.

## 7.1.1.5 Test description

### 7.1.1.5.1 Initial conditions

Initial conditions are a set of test configurations the UE needs to be tested in and the steps for the SS to take with the UE to reach the correct measurement state.

Test Environment: Normal, as defined in TS 36.508 [18] clause 4.1.

Frequencies to be tested: Mid Range, as defined in TS 36.508 [18] clause 4.3.1.

Channel Bandwidth to be tested: as defined in TS 36.508 [18] clause 4.3.1.

1. Connect SS and GSS to the UE antenna connector or antenna connectors as shown in Annex A.
2. Set the GNSS test parameters as specified in table 7.1.1.6 or 7.1.1.7 for GNSS scenario #1 in TS 37.571-5 [20]. For GNSS-1, select the first satellite SV ID defined in the relevant table of Satellites to be simulated in clause 6.2.1.2 in TS 37.571-5 [20] for the one satellite with the higher level.
3. The parameter settings for the cell are set up according to TS 36.508 [18] clause 4.4.3, single cell scenario.
4. Switch on the UE.
5. Establish a signalling connection according to the generic procedure in TS 36.508 [18] clause 4.5.3 (State 3, Generic RB established) on a channel in the Mid EARFCN range.



### 7.1.1.5.2 Test procedure

1. Start GNSS scenario #1 as specified in clause 6.2.1.2 of TS 37.571-5 [20] with the UE location randomly selected to be within 3 km of the Reference Location and the altitude of the UE randomly selected between 0 m to 500 m above WGS-84 reference ellipsoid using the method described in clause 6.2.1.2.6 of TS 37.571-5 [20]
2. Send a RESET UE POSITIONING STORED INFORMATION message.
3. Send an LPP REQUEST CAPABILITIES message.
4. The UE returns an LPP PROVIDE CAPABILITIES message indicating the assistance data supported by the UE in the Assistance Data Support List in the A GNSS Provide Capabilities IE.
5. Send an LPP PROVIDE ASSISTANCE DATA message to provide the assistance data that is supported by the UE as indicated in step 4 and in accordance with clause 6.2.6 of TS 37.571-5 [20], and with the values defined in clause 6.2.7 of TS 37.571-5 [20] with the value of GNSS Reference Time offset by a random value as specified in clause 6.2.7.2 of TS 37.571-5 [20] . If the UE message at step 4 includes the ackRequested IE set to TRUE, then the SS shall send an acknowledgment in the LPP PROVIDE ASSISTANCE DATA message.
6. Send an LPP REQUEST LOCATION INFORMATION message to obtain a fix.
7. If the UE returns a valid result in the LPP PROVIDE LOCATION INFORMATION message within the Max response time specified in table 7.1.1.9 then record the result and process it as specified in step 8. If the UE does not return a valid result within the Max response time specified in table 7.1.1.9 or reports an Error in the LPP PROVIDE LOCATION INFORMATION message then record one Bad Result.
- 7a. If the UE message at step 7 includes the ackRequested IE set to TRUE, then the SS shall send a LPP acknowledgment message.
8. For UE based testing compare the reported Location Information in the LPP PROVIDE LOCATION INFORMATION message against the simulated position of the UE used in step 1, and calculate the 2D position error as specified in clause 4.4.2.3. Compare the 2D position error against the value in table 7.1.1.9 and record one Good Result or Bad Result as appropriate; or  
  
For UE assisted testing convert the GNSS Signal Measurement Information reported in the LPP PROVIDE LOCATION INFORMATION message to a 2D position using the method described in clause 4.4.3 and then compare the result against the simulated position of the UE, used in step 1, and calculate the 2D position error as specified in clause 4.4.2.3. Compare the 2D position error against the value in table 7.1.1.9 and record one Good Result or Bad Result as appropriate.
9. Repeat steps 1 to 8 using GNSS scenario #2 instead of #1 so that the reference location changes sufficiently such that the UE shall have to use the new assistance data. For GNSS-1, select the first satellite SV ID defined in the relevant table of Satellites to be simulated in clause 6.2.1.2 in TS 37.571-5 [20] for the one satellite with the higher level. Use new random values for the UE location and altitude in step 1 and for the GNSS Reference Time offset in step 5.
10. Repeat steps 1 to 9 until the statistical requirements of clause 7.1.1.6 are met. Each time scenario #1 or #2 is used, the start time of the GNSS scenario shall be advanced by 2 minutes from the time used previously for that scenario. Once a scenario reaches the end of its viable running time, restart it from its nominal start time again. Each time scenario #1 or #2 is used, for GNSS-1 select the next satellite SV ID from the one used previously, defined in the relevant table of Satellites to be simulated in clause 6.2.1.2 in TS 37.571-5 [20], for the one satellite with the higher level.
11. Release the signalling connection.

### 7.1.1.5.3 Message contents

Message contents are according to TS 36.508 [18] clauses 4.6 and 4.7 and as follows:

#### RESET UE POSITIONING STORED INFORMATION

Information Element	Value/remark
UE POSITIONING TECHNOLOGY	AGNSS

## LPP REQUEST CAPABILITIES

Information Element	Value/remark
<i>a-gnss-RequestCapabilities</i>	TRUE

## LPP REQUEST LOCATION INFORMATION

Information Element	Value/remark	Comment
commonIEsRequestLocationInformation		
> locationInformationType	'locationEstimateRequired' or 'locationMeasurementsRequired'	Depending on test case and UE capabilities, i.e. support for UE-based or UE-assisted
> additionalInformation	'onlyReturnInformationRequested'	
> qos		
>> horizontalAccuracy	'19' (51.2m)	
>> verticalCoordinateRequest	FALSE	
>> responseTime	'20'	
a-gnss-RequestLocationInformation		
> gnss-PositioningInstructions		
>> gnssMethods		
>>> gnss-ids	Sub-test 1: 'gps' Sub-test 2: 'glonass' Sub-test 3: 'galileo' Sub-test 4: 'gps' Sub-test 5: 'gps' and 'glonass'	
>> fineTimeAssistanceMeasReq	FALSE	
>> adrMeasReq	FALSE	
>> multiFreqMeasReq	TRUE or FALSE	Depending on UE capabilities
>> assistanceAvailability	FALSE	

## 7.1.1.6 Test requirement

For the parameters specified in table 7.1.1.6 or 7.1.1.7 the UE shall meet the requirements and the success rate specified in table 7.1.1.9 with a confidence level of 95% according to Annex D.

**Table 7.1.1.6: Test parameters Sensitivity Coarse time assistance - Sub-Test 1**

Parameters	Unit	Value
Number of generated satellites	-	8
HDOP Range	-	1.1 to 1.6
Propagation conditions	-	AWGN
GPS Coarse Time assistance error range	seconds	$\pm 1.8$
GPS L1 C/A Signal for one satellite	dBm	-141
GPS L1 C/A Signal for remaining satellites	dBm	-146

**Table 7.1.1.7: Test parameters Sensitivity Coarse time assistance - Sub-Tests 2 to 5**

System	Parameters	Unit	Value
	Number of generated satellites per system	-	See Table 7.1.1.8
	Total number of generated satellites	-	6
	HDOP range		1.4 to 2.1
	Propagation conditions	-	AWGN
	GNSS coarse time assistance error range	seconds	$\pm 1.8$
Galileo	Reference high signal power level	dBm	-141
	Reference low signal power level	dBm	-146
GPS <sup>(1)</sup>	Reference high signal power level	dBm	-141
	Reference low signal power level	dBm	-146
GLONASS	Reference high signal power level	dBm	-141
	Reference low signal power level	dBm	-146
NOTE 1: "GPS" here means GPS L1 C/A, Modernized GPS, or both, dependent on UE capabilities.			

**Table 7.1.1.8: Power level and satellite allocation**

		Satellite allocation for each constellation		
		GNSS-1 <sup>(1)</sup>	GNSS-2	GNSS-3
Single constellation	High signal level	1	-	-
	Low signal level	5	-	-
Dual constellation	High signal level	1	-	-
	Low signal level	2	3	-
Triple constellation	High signal level	1	-	-
	Low signal level	1	2	2
Note 1: For GPS capable receivers, GNSS-1, i.e. the system having the satellite with high signal level, shall be GPS.				

**Table 7.1.1.9: Test requirements for Sensitivity Coarse Time Assistance**

System	Success rate	2-D position error	Max response time
All	95 %	101.3 m	20.3 s

## 7.1.2 Sensitivity Fine time assistance

### 7.1.2.1 Sub-tests

This test includes sub-tests dependent on the GNSS supported by the UE. Each sub-test is identified by a Sub-Test Number as defined in Table 7.1.2.1

**Table 7.1.2.1: Sub-Test Number Definition**

Sub-Test Number	Supported GNSS
1	UE supporting A-GPS L1C/A only
2	UE supporting A-GLONASS only
3	UE supporting A-Galileo only
4	UE supporting A-GPS and Modernized GPS only
5	UE supporting A-GPS and A-GLONASS only

### 7.1.2.2 Test purpose

To verify the performance of the first position estimate, when the UE is additionally provided with fine time assistance.

### 7.1.2.3 Test applicability

This test applies to all types of E-UTRA UE release 9 and forward that supports A-GNSS and that is capable of providing an enhanced performance when the network provides Fine Time Assistance.

### 7.1.2.4 Minimum conformance requirements

The first fix position estimates shall meet the accuracy and response time requirements in table 7.1.2.2 for the parameters specified in table 7.1.2.3 or 7.1.2.4.

**Table 7.1.2.2: Requirements Sensitivity Fine time assistance**

Success rate	2-D position error	Max response time
95 %	100 m	20 s

**Table 7.1.2.3: Parameters Sensitivity Fine time assistance - Sub-Test 1**

Parameters	Unit	Value
Number of generated satellites	-	8
HDOP Range	-	1.1 to 1.6
Propagation conditions	-	AWGN
GPS Coarse time assistance error range	seconds	$\pm 2$
GPS L1 C/A Fine time assistance error range	$\mu\text{s}$	$\pm 10$
GPS L1 C/A Signal for all satellites	dBm	-147

**Table 7.1.2.4: Parameters Sensitivity Fine time assistance - Sub-Tests 2 to 5**

System	Parameters	Unit	Value
	Number of generated satellites per system	-	See Table 7.1.2.5
	Total number of generated satellites	-	6
	HDOP range	-	1.4 to 2.1
	Propagation conditions	-	AWGN
	GNSS coarse time assistance error range	seconds	$\pm 2$
	GNSS fine time assistance error range	$\mu\text{s}$	$\pm 10$
Galileo	Reference signal power level	dBm	-147
GPS <sup>(1)</sup>	Reference signal power level	dBm	-147
GLONASS	Reference signal power level	dBm	-147
NOTE 1: "GPS" here means GPS L1 C/A, Modernized GPS, or both, dependent on UE capabilities.			

**Table 7.1.2.5: Satellite allocation**

	Satellite allocation for each constellation		
	GNSS-1	GNSS-2	GNSS-3
Single constellation	6	-	-
Dual constellation	3	3	-
Triple constellation	2	2	2

The normative reference for this requirement is TS 36.171 [3] clause 5.1.2 and 6.1.2.

## 7.1.2.5 Test description

### 7.1.2.5.1 Initial conditions

Initial conditions are a set of test configurations the UE needs to be tested in and the steps for the SS to take with the UE to reach the correct measurement state.

Test Environment: Normal, as defined in TS 36.508 [18] clause 4.1.

Frequencies to be tested: Mid Range, as defined in TS 36.508 [18] clause 4.3.1.

Channel Bandwidth to be tested: as defined in TS 36.508 [18] clause 4.3.1.

1. Connect SS and GSS to the UE antenna connector or antenna connectors as shown in Annex A.
2. Set the GNSS test parameters as specified in table 7.1.2.6 or 7.1.2.7 for GNSS scenario #1 in TS 37.571-5 [20].
3. The parameter settings for the cell are set up according to TS 36.508 [18] clause 4.4.3, single cell scenario.
4. Switch on the UE.
5. Establish a signalling connection according to the generic procedure in TS 36.508 [18] clause 4.5.3 (State 3, Generic RB established) on a channel in the Mid EARFCN range.

### 7.1.2.5.2 Test procedure

1. Start GNSS scenario #1 as specified in clause 6.2.1.2 of TS 37.571-5 [20] with the UE location randomly selected to be within 3 km of the Reference Location and the altitude of the UE randomly selected between 0 m to 500 m above WGS-84 reference ellipsoid using the method described in clause 6.2.1.2.6 of TS 37.571-5 [20]
2. Send a RESET UE POSITIONING STORED INFORMATION message.
3. Send an LPP REQUEST CAPABILITIES message.
4. The UE returns an LPP PROVIDE CAPABILITIES message indicating the assistance data supported by the UE in the Assistance Data Support List in the A GNSS Provide Capabilities IE.
5. Send an LPP PROVIDE ASSISTANCE DATA message to provide the assistance data that is supported by the UE as indicated in step 4 and in accordance with clause 6.2.6 of TS 37.571-5 [20], and with the values defined in clause 6.2.7 of TS 37.571-5 [20] with the value of GNSS Reference Time and GNSS Reference Time for one cell offset by a random value as specified in clause 6.2.7.2 of TS 37.571-5 [20]. If the UE message at step 4 includes the ackRequested IE set to TRUE, then the SS shall send an acknowledgment in the LPP PROVIDE ASSISTANCE DATA message.
6. Send an LPP REQUEST LOCATION INFORMATION message to obtain a fix.
7. If the UE returns a valid result in the LPP PROVIDE LOCATION INFORMATION message within the Max response time specified in table 7.1.2.9 then record the result and process it as specified in step 8. If the UE does not return a valid result within the Max response time specified in table 7.1.2.9 or reports an Error in the LPP PROVIDE LOCATION INFORMATION message then record one Bad Result.
- 7a. If the UE message at step 7 includes the ackRequested IE set to TRUE, then the SS shall send a LPP acknowledgment message.

8. For UE based testing compare the reported Location Information in the LPP PROVIDE LOCATION INFORMATION message against the simulated position of the UE used in step 1, and calculate the 2D position error as specified in clause 4.4.2.3. Compare the 2D position error against the value in table 7.1.2.9 and record one Good Result or Bad Result as appropriate; or

For UE assisted testing convert the GNSS Measurement Information reported in the LPP PROVIDE LOCATION INFORMATION message to a 2D position using the method described in clause 4.4.3 and then compare the result against the simulated position of the UE used in step 1, and calculate the 2D position error as specified in clause 4.4.2.3. Compare the 2D position error against the value in table 7.1.2.9 and record one Good Result or Bad Result as appropriate.

9. Repeat steps 1 to 8 using GNSS scenario #2 instead of #1 so that the reference location changes sufficiently such that the UE shall have to use the new assistance data. Use new random values for the UE location and altitude in step 1 and for the GNSS Reference Time GNSS Reference Time for one cell offsets in step 5.
10. Repeat steps 1 to 9 until the statistical requirements of clause 7.1.2.6 are met. Each time scenario #1 or #2 is used, the start time of the GNSS scenario shall be advanced by 2 minutes from the time used previously for that scenario. Once a scenario reaches the end of its viable running time, restart it from its nominal start time again.
11. Release the signalling connection.

### 7.1.2.5.3 Message contents

Message contents are according to TS 36.508 [18] clauses 4.6 and 4.7 and as follows:

#### RESET UE POSITIONING STORED INFORMATION

Information Element	Value/remark
UE POSITIONING TECHNOLOGY	AGNSS

#### LPP REQUEST CAPABILITIES

Information Element	Value/remark
<i>a-gnss-RequestCapabilities</i>	TRUE

#### LPP REQUEST LOCATION INFORMATION

Information Element	Value/remark	Comment
commonIEsRequestLocationInformation		
> locationInformationType	'locationEstimateRequired' or 'locationMeasurementsRequired'	Depending on test case and UE capabilities, i.e. support for UE-based or UE-assisted
> additionalInformation	'onlyReturnInformationRequested'	
> qos		
>> horizontalAccuracy	'19' (51.2m)	
>> verticalCoordinateRequest	FALSE	
>> responseTime	'20'	
a-gnss-RequestLocationInformation		
> gnss-PositioningInstructions		
>> gnssMethods		
>>> gnss-ids	Sub-test 1: 'gps' Sub-test 2: 'glonass' Sub-test 3: 'galileo' Sub-test 4: 'gps' Sub-test 4: 'gps' and 'glonass'	
>> fineTimeAssistanceMeasReq	FALSE	
>> adrMeasReq	FALSE	
>> multiFreqMeasReq	TRUE or FALSE	Depending on UE capabilities
>> assistanceAvailability	FALSE	

## 7.1.2.6 Test requirement

For the parameters specified in table 7.1.2.6 or 7.1.2.7 the UE shall meet the requirements and the success rate specified in table 7.1.2.9 with a confidence level of 95% according to Annex D.

**Table 7.1.2.6: Test parameters Sensitivity Fine time assistance - Sub-Test 1**

Parameters	Unit	Value
Number of generated satellites	-	8
HDOP Range	-	1.1 to 1.6
Propagation conditions	-	AWGN
GPS Coarse time assistance error range	seconds	$\pm 1.8$
GPS Fine Time assistance error range	$\mu\text{s}$	$\pm 9$
GPS L1 C/A Signal for all satellites	dBm	-146

**Table 7.1.2.7: Test parameters Sensitivity Fine time assistance - Sub-Tests 2 to 5**

System	Parameters	Unit	Value
	Number of generated satellites per system	-	See Table 7.1.2.8
	Total number of generated satellites	-	6
	HDOP range	-	1.4 to 2.1
	Propagation conditions	-	AWGN
	GNSS coarse time assistance error range	seconds	$\pm 1.8$
	GNSS fine time assistance error range	$\mu\text{s}$	$\pm 9$
Galileo	Reference signal power level	dBm	-146
GPS <sup>(1)</sup>	Reference signal power level	dBm	-146
GLONASS	Reference signal power level	dBm	-146
NOTE 1: "GPS" here means GPS L1 C/A, Modernized GPS, or both, dependent on UE capabilities.			

**Table 7.1.2.8: Satellite allocation**

	Satellite allocation for each constellation		
	GNSS-1	GNSS-2	GNSS-3
Single constellation	6	-	-
Dual constellation	3	3	-
Triple constellation	2	2	2

**Table 7.1.2.9: Test requirements for Sensitivity Fine Time Assistance**

System	Success rate	2-D position error	Max response time
All	95 %	101.3 m	20.3 s

## 7.2 Nominal Accuracy

### 7.2.1 Sub-tests

This test includes sub-tests dependent on the GNSS supported by the UE. Each sub-test is identified by a Sub-Test Number as defined in Table 7.2.1

**Table 7.2.1: Sub-Test Number Definition**

Sub-Test Number	Supported GNSS
1	UE supporting A-GPS L1C/A only
2	UE supporting A-GLONASS only
3	UE supporting A-Galileo only
4	UE supporting A-GPS and Modernized GPS only
5	UE supporting A-GPS and A-GLONASS only

## 7.2.2 Test purpose

To verify the performance of the first position estimate, when the UE is provided with ideal GNSS signal conditions.

## 7.2.3 Test applicability

This test applies to all types of E-UTRA UE release 9 and forward that supports A-GNSS.

## 7.2.4 Minimum conformance requirements

The first fix position estimates shall meet the accuracy and response time requirements in table 7.2.2 or 7.2.3 for the parameters specified in table 7.2.4 or 7.2.5.

**Table 7.2.2: Requirements Nominal Accuracy - Sub-Test 1**

Success rate	2-D position error	Max response time
95 %	30 m	20 s

**Table 7.2.3: Requirements Nominal Accuracy - Sub-Tests 2 to 5**

Success rate	2-D position error	Max response time
95 %	15 m	20 s

**Table 7.2.4: Parameters Nominal Accuracy - Sub-Test 1**

Parameters	Unit	Value
Number of generated satellites	-	8
HDOP Range	-	1.1 to 1.6
Propagation conditions	-	AWGN
GPS Coarse Time assistance error range	seconds	±2
GPS L1 C/A Signal for all satellites	dBm	-130



**Table 7.2.5: Parameters Nominal Accuracy - Sub-Tests 2 to 5**

System	Parameters	Unit	Value
	Number of generated satellites per system	-	See Table 7.2.6
	Total number of generated satellites	-	6 or 7 <sup>(2)</sup>
	HDOP Range	-	1.4 to 2.1
	Propagation conditions	-	AWGN
	GNSS coarse time assistance error range	seconds	±2
GPS <sup>(1)</sup>	Reference signal power level for all satellites	dBm	-128.5
Galileo	Reference signal power level for all satellites	dBm	-127
GLONASS	Reference signal power level for all satellites	dBm	-131
QZSS	Reference signal power level for all satellites	dBm	-128.5
SBAS	Reference signal power level for all satellites	dBm	-131
NOTE 1: "GPS" here means GPS L1 C/A, Modernized GPS, or both, dependent on UE capabilities.			
NOTE 2: 7 satellites apply only for SBAS case.			

If QZSS is supported, one of the GPS satellites will be replaced by a QZSS satellite with respective signal support.

If SBAS is supported, the SBAS satellite with the highest elevation will be added to the scenario.

**Table 7.2.6: Satellite allocation**

	Satellite allocation for each constellation			
	GNSS 1 <sup>(1)</sup>	GNSS 2 <sup>(1)</sup>	GNSS 3 <sup>(1)</sup>	SBAS
Single constellation	6	--	--	1
Dual constellation	3	3	--	1
Triple constellation	2	2	2	1
NOTE 1: GNSS refers to global systems i.e., GPS, Galileo, GLONASS				

The normative reference for this requirement is TS 36.171 [3] clause 5.2 and 6.2.

## 7.2.5 Test description

### 7.2.5.1 Initial conditions

Initial conditions are a set of test configurations the UE needs to be tested in and the steps for the SS to take with the UE to reach the correct measurement state.

Test Environment: Normal, as defined in TS 36.508 [18] clause 4.1.

Frequencies to be tested: Mid Range, as defined in TS 36.508 [18] clause 4.3.1.

Channel Bandwidth to be tested: as defined in TS 36.508 [18] clause 4.3.1.

1. Connect SS and GSS to the UE antenna connector or antenna connectors as shown in Annex A.
2. Set the GNSS test parameters as specified in table 7.2.7 or 7.2.8 for GNSS scenario #3 in TS 37.571-5 [20].
3. The parameter settings for the cell are set up according to TS 36.508 [18] clause 4.4.3, single cell scenario.
4. Switch on the UE.
5. Establish a signalling connection according to the generic procedure in TS 36.508 [18] clause 4.5.3 (State 3, Generic RB established) on a channel in the Mid EARFCN range.

### 7.2.5.2 Test procedure

1. Start GNSS scenario #3 as specified in clause 6.2.1.2 of TS 37.571-5 [20] with the UE location randomly selected to be within 3 km of the Reference Location and the altitude of the UE randomly selected between 0 m to 500 m above WGS-84 reference ellipsoid using the method described in clause 6.2.1.2.6 of TS 37.571-5 [20]
2. Send a RESET UE POSITIONING STORED INFORMATION message.

3. Send an LPP REQUEST CAPABILITIES message.
4. The UE returns an LPP PROVIDE CAPABILITIES message indicating the assistance data supported by the UE in the Assistance Data Support List in the A GNSS Provide Capabilities IE.
5. Send an LPP PROVIDE ASSISTANCE DATA message to provide the assistance data that is supported by the UE as indicated in the step 4 and in accordance with clause 6.2.6 of TS 37.571-5 [20], and with the values defined in clause 6.2.7 of TS 37.571-5 [20] with the value of GNSS Reference Time offset by a random value as specified in clause 6.2.7.2 of TS 37.571-5 [20]. If the UE message at step 4 includes the ackRequested IE set to TRUE, then the SS shall send an acknowledgment in the (first) LPP PROVIDE ASSISTANCE DATA message.
6. Send an LPP REQUEST LOCATION INFORMATION message to obtain a fix.
7. If the UE returns a valid result in the LPP PROVIDE LOCATION INFORMATION message within the Max response time specified in table 7.2.10 then record the result and process it as specified in step 8. If the UE does not return a valid result within the Max response time specified in table 7.2.10 or reports an Error in the LPP PROVIDE LOCATION INFORMATION message then record one Bad Result.
- 7a. If the UE message at step 7 includes the ackRequested IE set to TRUE, then the SS shall send a LPP acknowledgment message.
8. For UE based testing compare the reported Location Information in the LPP PROVIDE LOCATION INFORMATION message against the simulated position of the UE used in step 1, and calculate the 2D position error as specified in clause 4.4.2.3. Compare the 2D position error against the value in table 7.2.10 and record one Good Result or Bad Result as appropriate; or

For UE assisted testing convert the GNSS Measurement Information reported in the LPP PROVIDE LOCATION INFORMATION message to a 2D position using the method described in clause 4.4.3 and then compare the result against the simulated position of the UE used in step 1, and calculate the 2D position error as specified in clause 4.4.2.3. Compare the 2D position error against the value in table 7.2.10 and record one Good Result or Bad Result as appropriate.

9. Repeat steps 1 to 8 using GNSS scenario #4 instead of #3 so that the reference location changes sufficiently such that the UE shall have to use the new assistance data. Use new random values for the UE location and altitude in step 1 and for the GNSS Reference Time offset in step 5.
10. Repeat steps 1 to 9 until the statistical requirements of clause 7.2.6 are met. Each time scenario #3 or #4 is used, the start time of the GNSS scenario shall be advanced by 2 minutes from the time used previously for that scenario. Once a scenario reaches the end of its viable running time, restart it from its nominal start time again.
11. Release the signalling connection.

### 7.2.5.3 Message contents

Message contents are according to TS 36.508 [18] clauses 4.6 and 4.7 and as follows:

#### RESET UE POSITIONING STORED INFORMATION

Information Element	Value/remark
UE POSITIONING TECHNOLOGY	AGNSS

#### LPP REQUEST CAPABILITIES

Information Element	Value/remark
<i>a-gnss-RequestCapabilities</i>	TRUE

#### LPP REQUEST LOCATION INFORMATION

Information Element	Value/remark	Comment
commonIEsRequestLocationInformation		
> locationInformationType	'locationEstimateRequired' or 'locationMeasurementsRequired'	Depending on test case and UE capabilities, i.e. support for UE-based or UE-assisted
> additionalInformation	'onlyReturnInformationRequested'	
> qos		
>> horizontalAccuracy (Sub Test 1)	'10' (15.9m)	
>> horizontalAccuracy (Sub Tests 2 to 5)	'6' (7.7m)	
>> verticalCoordinateRequest	FALSE	
>> responseTime	'20'	
a-gnss-RequestLocationInformation		
> gnss-PositioningInstructions		
>> gnssMethods		
>>> gnss-ids	Sub-test 1: 'gps' and possibly 'sbas' and/or 'qzss' Sub-test 2: 'glonass' and possibly 'sbas' and/or 'qzss' Sub-test 3: 'galileo' and possibly 'sbas' and/or 'qzss' Sub-test 4: 'gps' and possibly 'sbas' and/or 'qzss' Sub-test 5: 'gps' and 'glonass' and possibly 'sbas' and/or 'qzss'	Depending on UE capabilities
>> fineTimeAssistanceMeasReq	FALSE	
>> adrMeasReq	FALSE	
>> multiFreqMeasReq	TRUE or FALSE	Depending on UE capabilities
>> assistanceAvailability	FALSE	

## 7.2.6 Test requirement

For the parameters specified in table 7.2.7 or 7.2.8 the UE shall meet the requirements and the success rate specified in table 7.2.10 or 7.2.11 with a confidence level of 95% according to Annex D.

**Table 7.2.7: Test parameters Nominal Accuracy - Sub-Test 1**

Parameters	Unit	Value
Number of generated satellites	-	8
HDOP Range	-	1.1 to 1.6
Propagation conditions	-	AWGN
GPS Coarse Time assistance error range	seconds	±1.8
GPS L1 C/A Signal for all satellites	dBm	-130

**Table 7.2.8: Test parameters Nominal Accuracy - Sub-Tests 2 to 5**

System	Parameters	Unit	Value
	Number of generated satellites per system	-	See Table 7.2.9
	Total number of generated satellites	-	6 or 7 <sup>(2)</sup>
	HDOP Range	-	1.4 to 2.1
	Propagation conditions	-	AWGN
	GNSS coarse time assistance error range	seconds	±1.8
GPS <sup>(1)</sup>	Reference signal power level for all satellites	dBm	-128.5
Galileo	Reference signal power level for all satellites	dBm	-127
GLONASS	Reference signal power level for all satellites	dBm	-131
QZSS	Reference signal power level for all satellites	dBm	-128.5
SBAS	Reference signal power level for all satellites	dBm	-131
NOTE 1: "GPS" here means GPS L1 C/A, Modernized GPS, or both, dependent on UE capabilities.			
NOTE 2: 7 satellites apply only for SBAS case.			

If QZSS is supported, one of the GPS satellites will be replaced by a QZSS satellite with respective signal support.

If SBAS is supported, the SBAS satellite with the highest elevation will be added to the scenario.

**Table 7.2.9: Satellite allocation**

	Satellite allocation for each constellation			
	GNSS 1 <sup>(1)</sup>	GNSS 2 <sup>(1)</sup>	GNSS 3 <sup>(1)</sup>	SBAS
Single constellation	6	--	--	1
Dual constellation	3	3	--	1
Triple constellation	2	2	2	1
NOTE 1: GNSS refers to global systems i.e., GPS, Galileo, GLONASS				

**Table 7.2.10: Test requirements for Nominal Accuracy – Sub Test 1**

System	Success rate	2-D position error	Max response time
All	95 %	31.3 m	20.3 s

**Table 7.2.11: Test requirements for Nominal Accuracy – Sub Tests 2 to 5**

System	Success rate	2-D position error	Max response time
All	95 %	16.3 m	20.3 s

## 7.3 Dynamic Range

### 7.3.1 Sub-tests

This test includes sub-tests dependent on the GNSS supported by the UE. Each sub-test is identified by a Sub-Test Number as defined in Table 7.3.1

**Table 7.3.1: Sub-Test Number Definition**

Sub-Test Number	Supported GNSS
1	UE supporting A-GPS L1C/A only
2	UE supporting A-GLONASS only
3	UE supporting A-Galileo only
4	UE supporting A-GPS and Modernized GPS only
5	UE supporting A-GPS and A-GLONASS only

### 7.3.2 Test purpose

To verify the performance of the first position estimate, when the UE is provided with GNSS signals with large dynamic ranges.

### 7.3.3 Test applicability

This test applies to all types of E-UTRA UE release 9 and forward that supports A-GNSS.

### 7.3.4 Minimum conformance requirements

The first fix position estimates shall meet the accuracy and response time requirements in table 7.3.2 for the parameters specified in table 7.3.3 or 7.3.4.

**Table 7.3.2: Requirements Dynamic Range**

Success rate	2-D position error	Max response time
95 %	100 m	20 s

**Table 7.3.3: Parameters Dynamic Range - Sub-Test 1**

Parameters	Unit	Value
Number of generated satellites	-	6
HDOP Range	-	1.4 to 2.1
GPS Coarse Time assistance error range	seconds	±2
Propagation conditions	-	AWGN
GPS L1 C/A Signal for 1 <sup>st</sup> satellite	dBm	-129
GPS L1 C/A Signal for 2 <sup>nd</sup> satellite	dBm	-135
GPS L1 C/A Signal for 3 <sup>rd</sup> satellite	dBm	-141
GPS L1 C/A Signal for 4 <sup>th</sup> satellite	dBm	-147
GPS L1 C/A Signal for 5 <sup>th</sup> satellite	dBm	-147
GPS L1 C/A Signal for 6 <sup>th</sup> satellite	dBm	-147

**Table 7.3.4: Parameters Dynamic Range - Sub-Tests 2 to 5**

System	Parameters	Unit	Value
	Number of generated satellites per system	-	See Table 7.3.5
	Total number of generated satellites	-	6
	HDOP Range	-	1.4 to 2.1
	Propagation conditions	-	AWGN
	GNSS coarse time assistance error range	seconds	±2
Galileo	Reference high signal power level	dBm	-127.5
	Reference low signal power level	dBm	-147
GPS <sup>(1)</sup>	Reference high signal power level	dBm	-129
	Reference low signal power level	dBm	-147
GLONASS	Reference high signal power level	dBm	-131.5
	Reference low signal power level	dBm	-147
NOTE 1: "GPS" here means GPS L1 C/A, Modernized GPS, or both, dependent on UE capabilities.			

**Table 7.3.5: Power level and satellite allocation**

		Satellite allocation for each constellation		
		GNSS 1 <sup>(1)</sup>	GNSS 2 <sup>(1)</sup>	GNSS 3 <sup>(1)</sup>
Single constellation	High signal level	2	--	--
	Low signal level	4	--	--
Dual constellation	High signal level	1	1	--
	Low signal level	2	2	--
Triple constellation	High signal level	1	1	1
	Low signal level	1	1	1

NOTE 1: GNSS refers to global systems i.e., GPS, Galileo, GLONASS

The normative reference for this requirement is TS 36.171 [3] clause 5.3 and 6.3.

## 7.3.5 Test description

### 7.3.5.1 Initial conditions

Initial conditions are a set of test configurations the UE needs to be tested in and the steps for the SS to take with the UE to reach the correct measurement state.

Test Environment: Normal, as defined in TS 36.508 [18] clause 4.1.

Frequencies to be tested: Mid Range, as defined in TS 36.508 [18] clause 4.3.1.

Channel Bandwidth to be tested: as defined in TS 36.508 [18] clause 4.3.1.

1. Connect SS and GSS to the UE antenna connector or antenna connectors as shown in Annex A.
2. Set the GNSS test parameters as specified in table 7.3.6 or 7.3.7 for GNSS scenario #1 in TS 37.571-5 [20]. Randomly select from the satellite SV IDs defined in the relevant table of Satellites to be simulated in clause 6.2.1.2 in TS 37.571-5 [20] for the satellites with the higher levels.
3. The parameter settings for the cell are set up according to TS 36.508 [18] clause 4.4.3, single cell scenario.
4. Switch on the UE.
5. Establish a signalling connection according to the generic procedure in TS 36.508 [18] clause 4.5.3 (State 3, Generic RB established) on a channel in the Mid EARFCN range.

### 7.3.5.2 Test procedure

1. Start GNSS scenario #1 as specified in clause 6.2.1.2 of TS 37.571-5 [20] with the UE location randomly selected to be within 3 km of the Reference Location and the altitude of the UE randomly selected between 0 m to 500 m above WGS-84 reference ellipsoid using the method described in clause 6.2.1.2.6 of TS 37.571-5 [20]
2. Send a RESET UE POSITIONING STORED INFORMATION message.
3. Send an LPP REQUEST CAPABILITIES message.
4. The UE returns an LPP PROVIDE CAPABILITIES message indicating the assistance data supported by the UE in the Assistance Data Support List in the A GNSS Provide Capabilities IE.
5. Send an LPP PROVIDE ASSISTANCE DATA message to provide the assistance data that is supported by the UE as indicated in the step 4 and in accordance with clause 6.2.6 of TS 37.571-5 [20], and with the values defined in clause 6.2.7 of TS 37.571-5 [20] with the value of GNSS Reference Time offset by a random value as specified in clause 6.2.7.2 of TS 37.571-5 [20]. If the UE message at step 4 includes the ackRequested IE set to TRUE, then the SS shall send an acknowledgment in the (first) LPP PROVIDE ASSISTANCE DATA message.
6. Send an LPP REQUEST LOCATION INFORMATION message to obtain a fix.
7. If the UE returns a valid result in the LPP PROVIDE LOCATION INFORMATION message within the Max response time specified in table 7.3.9 then record the result and process it as specified in step 8. If the UE does

not return a valid result within the Max response time specified in table 7.3.9 or reports an Error in the LPP PROVIDE LOCATION INFORMATION message then record one Bad Result.

- 7a. If the UE message at step 7 includes the ackRequested IE set to TRUE, then the SS shall send a LPP acknowledgment message.
8. For UE based testing compare the reported Location Information in the LPP PROVIDE LOCATION INFORMATION message against the simulated position of the UE used in step 1, and calculate the 2D position error as specified in clause 4.4.2.3. Compare the 2D position error against the value in table 7.3.9 and record one Good Result or Bad Result as appropriate; or

For UE assisted testing convert the GNSS Measurement Information reported in the LPP PROVIDE LOCATION INFORMATION message to a 2D position using the method described in clause 4.4.3 and then compare the result against the simulated position of the UE used in step 1, and calculate the 2D position error as specified in clause 4.4.2.3. Compare the 2D position error against the value in table 7.3.9 and record one Good Result or Bad Result as appropriate.

9. Repeat steps 1 to 8 using GNSS scenario #2 instead of #1 so that the reference location changes sufficiently such that the UE shall have to use the new assistance data. Randomly select from the satellite SV IDs defined in the relevant table of Satellites to be simulated in clause 6.2.1.2 in TS 37.571-5 [20] for the satellites with the higher levels. Use new random values for the UE location and altitude in step 1 and for the GNSS Reference Time offset in step 5.
10. Repeat steps 1 to 9 until the statistical requirements of clause 7.3.6 are met. Each time scenario #1 or #2 is used, the start time of the GNSS scenario shall be advanced by 2 minutes from the time used previously for that scenario. Once a scenario reaches the end of its viable running time, restart it from its nominal start time again. Each time scenario #1 or #2 is used, randomly select from the satellite SV IDs defined in the relevant table of Satellites to be simulated in clause 6.2.1.2 in TS 37.571-5 [20], for the satellites with the higher levels.
11. Release the signalling connection.

### 7.3.5.3 Message contents

Message contents are according to TS 36.508 [18] clauses 4.6 and 4.7 and as follows:

#### RESET UE POSITIONING STORED INFORMATION

Information Element	Value/remark
UE POSITIONING TECHNOLOGY	AGNSS

#### LPP REQUEST CAPABILITIES

Information Element	Value/remark
<i>a-gnss-RequestCapabilities</i>	TRUE

#### LPP REQUEST LOCATION INFORMATION

Information Element	Value/remark	Comment
commonIEsRequestLocationInformation		
> locationInformationType	'locationEstimateRequired' or 'locationMeasurementsRequired'	Depending on test case and UE capabilities, i.e. support for UE-based or UE-assisted
> additionalInformation	'onlyReturnInformationRequested'	
> qos		
>> horizontalAccuracy	'19' (51.2m)	
>> verticalCoordinateRequest	FALSE	
>> responseTime	'20'	
a-gnss-RequestLocationInformation		
> gnss-PositioningInstructions		
>> gnssMethods		
>>> gnss-ids	Sub-test 1: 'gps' Sub-test 2: 'glonass' Sub-test 3: 'galileo' Sub-test 4: 'gps' Sub-test 5: 'gps' and 'glonass'	
>> fineTimeAssistanceMeasReq	FALSE	
>> adrMeasReq	FALSE	
>> multiFreqMeasReq	TRUE or FALSE	Depending on UE capabilities
>> assistanceAvailability	FALSE	

### 7.3.6 Test requirement

For the parameters specified in table 7.3.6 or 7.3.7 the UE shall meet the requirements and the success rate specified in table 7.3.9 with a confidence level of 95% according to Annex D.

**Table 7.3.6: Test parameters Dynamic Range - Sub-Test 1**

Parameters	Unit	Value
Number of generated satellites	-	6
HDOP Range	-	1.4 to 2.1
GPS Coarse Time assistance error range	seconds	±1.8
Propagation conditions	-	AWGN
GPS L1 C/A Signal for 1 <sup>st</sup> satellite	dBm	-128.2
GPS L1 C/A Signal for 2 <sup>nd</sup> satellite	dBm	-134
GPS L1 C/A Signal for 3 <sup>rd</sup> satellite	dBm	-140
GPS L1 C/A Signal for 4 <sup>th</sup> satellite	dBm	-146
GPS L1 C/A Signal for 5 <sup>th</sup> satellite	dBm	-146
GPS L1 C/A Signal for 6 <sup>th</sup> satellite	dBm	-146



**Table 7.3.7: Test parameters Dynamic Range - Sub-Tests 2 to 5**

System	Parameters	Unit	Value
	Number of generated satellites per system	-	See Table 7.3.8
	Total number of generated satellites	-	6
	HDOP Range	-	1.4 to 2.1
	Propagation conditions	-	AWGN
	GNSS coarse time assistance error range	seconds	±1.8
Galileo	Reference high signal power level	dBm	-126.7
	Reference low signal power level	dBm	-146
GPS <sup>(1)</sup>	Reference high signal power level	dBm	-128.2
	Reference low signal power level	dBm	-146
GLONASS	Reference high signal power level	dBm	-130.7
	Reference low signal power level	dBm	-146
NOTE 1: "GPS" here means GPS L1 C/A, Modernized GPS, or both, dependent on UE capabilities.			

**Table 7.3.8: Power level and satellite allocation**

		Satellite allocation for each constellation		
		GNSS 1 <sup>(1)</sup>	GNSS 2 <sup>(1)</sup>	GNSS 3 <sup>(1)</sup>
Single constellation	High signal level	2	--	--
	Low signal level	4	--	--
Dual constellation	High signal level	1	1	--
	Low signal level	2	2	--
Triple constellation	High signal level	1	1	1
	Low signal level	1	1	1
NOTE 1: GNSS refers to global systems i.e., GPS, Galileo, GLONASS				

**Table 7.3.9: Test requirements for Dynamic Range**

System	Success rate	2-D position error	Max response time
All	95 %	101.3 m	20.3 s

## 7.4 Multi-Path scenario

### 7.4.1 Sub-tests

This test includes sub-tests dependent on the GNSS supported by the UE. Each sub-test is identified by a Sub-Test Number as defined in Table 7.4.1

**Table 7.4.1: Sub-Test Number Definition**

Sub-Test Number	Supported GNSS
1	UE supporting A-GPS L1C/A only
2	UE supporting A-GLONASS only
3	UE supporting A-Galileo only
4	UE supporting A-GPS and Modernized GPS only
5	UE supporting A-GPS and A-GLONASS only

### 7.4.2 Test purpose

To verify the performance of the first position estimate, when the UE is provided with GNSS signals with multi-path components.

### 7.4.3 Test applicability

This test applies to all types of E-UTRA UE release 9 and forward that supports A-GNSS.

### 7.4.4 Minimum conformance requirements

The first fix position estimates shall meet the accuracy and response time requirements in table 7.4.2 for the parameters specified in table 7.4.3 or 7.4.4.

**Table 7.4.2: Requirements Multi-Path scenario**

Success rate	2-D position error	Max response time
95 %	100 m	20 s

**Table 7.4.3: Parameters Multi-Path scenario - Sub-Test 1**

Parameters	Unit	Value
Number of generated satellites (Satellites 1, 2 unaffected by multi-path) (Satellites 3, 4, 5 affected by multi-path)	-	5
GPS Coarse time assistance error range	seconds	±2
HDOP Range	-	1.8 to 2.5
GPS L1 C/A Signal for satellite 1, 2	dBm	-130
GPS L1 C/A Signal for satellite 3, 4, 5	dBm	LOS signal of -130 dBm, multi-path signal of -136 dBm

**Table 7.4.4: Parameters Multi-Path scenario - Sub-Tests 2 to 5**

System	Parameters	Unit	Value
	Number of generated satellites per system	-	See Table 7.4.5
	Total number of generated satellites	-	6
	HDOP range	-	1.4 to 2.1
	Propagation conditions	-	AWGN
	GNSS coarse time assistance error range	seconds	±2
Galileo	Reference signal power level	dBm	-127
GPS <sup>(1)</sup>	Reference signal power level	dBm	-128.5
GLONASS	Reference signal power level	dBm	-131
NOTE 1: "GPS" here means GPS L1 C/A, Modernized GPS, or both, dependent on UE capabilities.			

**Table 7.4.5: Channel model allocation**

		Channel model allocation for each constellation		
		GNSS-1	GNSS-2	GNSS-3
Single constellation	One-tap channel	2	--	--
	Two-tap channel	4	--	--
Dual constellation	One-tap channel	1	1	--
	Two-tap channel	2	2	--
Triple constellation	One-tap channel	1	1	1
	Two-tap channel	1	1	1

The normative reference for this requirement is TS 36.171 [3] clause 5.4 and 6.4.

## 7.4.5 Test description

### 7.4.5.1 Initial conditions

Initial conditions are a set of test configurations the UE needs to be tested in and the steps for the SS to take with the UE to reach the correct measurement state.

Test Environment: Normal, as defined in TS 36.508 [18] clause 4.1.

Frequencies to be tested: Mid Range, as defined in TS 36.508 [18] clause 4.3.1.

Channel Bandwidth to be tested: as defined in TS 36.508 [18] clause 4.3.1.

1. Connect SS and GSS to the UE antenna connector or antenna connectors as shown in Annex A.
2. Set the GNSS test parameters as specified in table 7.4.6 or 7.4.7 for GNSS scenario #1 in TS 37.571-5 [20]. Randomly select from the satellite SV IDs defined in the relevant table of Satellites to be simulated in clause 6.2.1.2 in TS 37.571-5 [20] for the satellites with one-tap channels.
3. The parameter settings for the cell are set up according to TS 36.508 [18] clause 4.4.3, single cell scenario.
4. Switch on the UE.
5. Establish a signalling connection according to the generic procedure in TS 36.508 [18] clause 4.5.3 (State 3, Generic RB established) on a channel in the Mid EARFCN range.

### 7.4.5.2 Test procedure

1. Start GNSS scenario #1 as specified in clause 6.2.1.2 of TS 37.571-5 [20] with the UE location randomly selected to be within 3 km of the Reference Location and the altitude of the UE randomly selected between 0 m to 500 m above WGS-84 reference ellipsoid using the method described in clause 6.2.1.2.6 of TS 37.571-5 [20]. The initial carrier phase difference between taps of the multi-path model shall be randomly selected between 0 and  $2\pi$  radians by selecting the next random number from a standard uniform random number generator, in the range 0 to  $2\pi$ , representing radians with a resolution of 0.1, representing 0.1 radians.
2. Send a RESET UE POSITIONING STORED INFORMATION message.
3. Send an LPP REQUEST CAPABILITIES message.
4. The UE returns an LPP PROVIDE CAPABILITIES message indicating the assistance data supported by the UE in the Assistance Data Support List in the A GNSS Provide Capabilities IE.
5. Send an LPP PROVIDE ASSISTANCE DATA message to provide the assistance data that is supported by the UE as indicated in the step 4 and in accordance with clause 6.2.6 of TS 37.571-5 [20], and with the values defined in clause 6.2.7 of TS 37.571-5 [20] with the value of GNSS Reference Time offset by a random value as specified in clause 6.2.7.2 of TS 37.571-5 [20]. If the UE message at step 4 includes the ackRequested IE set to TRUE, then the SS shall send an acknowledgment in the LPP PROVIDE ASSISTANCE DATA message.
6. Send an LPP REQUEST LOCATION INFORMATION message to obtain a fix.
7. If the UE returns a valid result in the LPP PROVIDE LOCATION INFORMATION message within the Max response time specified in table 7.4.10 then record the result and process it as specified in step 8. If the UE does not return a valid result within the Max response time specified in table 7.4.10 or reports an Error in the LPP PROVIDE LOCATION INFORMATION message then record one Bad Result.
- 7a. If the UE message at step 7 includes the ackRequested IE set to TRUE, then the SS shall send a LPP acknowledgment message.
8. For UE based testing compare the reported Location Information in the LPP PROVIDE LOCATION INFORMATION message against the simulated position of the UE used in step 1, and calculate the 2D position error as specified in clause 4.4.2.3. Compare the 2D position error against the value in table 7.4.10 and record one Good Result or Bad Result as appropriate; or

For UE assisted testing convert the GNSS Measurement Information reported in the LPP PROVIDE LOCATION INFORMATION message to a 2D position using the method described in clause 4.4.3 and then

compare the result against the simulated position of the UE used in step 1, and calculate the 2D position error as specified in clause 4.4.2.3. Compare the 2D position error against the value in table 7.4.10 and record one Good Result or Bad Result as appropriate.

9. Repeat steps 1 to 8 using GNSS scenario #2 instead of #1 so that the reference location changes sufficiently such that the UE shall have to use the new assistance data. Randomly select from the satellite SV IDs defined in the relevant table of Satellites to be simulated in clause 6.2.1.2 in TS 37.571-5 [20] for the satellites with the one-tap channels. Use new random values for the UE location and altitude, and the initial carrier phase difference between taps of the multi-path model in step 1 and for the GNSS Reference Time offset in step 5.
10. Repeat steps 1 to 9 until the statistical requirements of clause 7.4.6 are met. Each time scenario #1 or #2 is used, the start time of the GNSS scenario shall be advanced by 2 minutes from the time used previously for that scenario. Once a scenario reaches the end of its viable running time, restart it from its nominal start time again. Each time scenario #1 or #2 is used, randomly select from the satellite SV IDs defined in the relevant table of Satellites to be simulated in clause 6.2.1.2 in TS 37.571-5 [20], for the satellites with the one-tap channels.
11. Release the signalling connection

### 7.4.5.3 Message contents

Message contents are according to TS 36.508 [18] clauses 4.6 and 4.7 and as follows:

#### RESET UE POSITIONING STORED INFORMATION

Information Element	Value/remark
UE POSITIONING TECHNOLOGY	AGNSS

#### LPP REQUEST CAPABILITIES

Information Element	Value/remark
<i>a-gnss-RequestCapabilities</i>	TRUE

#### LPP REQUEST LOCATION INFORMATION

Information Element	Value/remark	Comment
commonEsRequestLocationInformation		
> locationInformationType	'locationEstimateRequired' or 'locationMeasurementsRequired'	Depending on test case and UE capabilities, i.e. support for UE-based or UE-assisted
> additionalInformation	'onlyReturnInformationRequested'	
> qos		
>> horizontalAccuracy	'19' (51.2m)	
>> verticalCoordinateRequest	FALSE	
>> responseTime	'20'	
a-gnss-RequestLocationInformation		
> gnss-PositioningInstructions		
>> gnssMethods		
>>> gnss-ids	Sub-test 1: 'gps' Sub-test 2: 'glonass' Sub-test 3: 'galileo' Sub-test 4: 'gps' Sub-test 5: 'gps' and 'glonass'	
>> fineTimeAssistanceMeasReq	FALSE	
>> adrMeasReq	FALSE	
>> multiFreqMeasReq	TRUE or FALSE	Depending on UE capabilities
>> assistanceAvailability	FALSE	

## 7.4.6 Test requirement

For the parameters specified in table 7.4.6 or 7.4.7 the UE shall meet the requirements and the success rate specified in table 7.4.10 with a confidence level of 95% according to Annex D.

**Table 7.4.6: Test parameters Multi-Path scenario - Sub-Test 1**

Parameters	Unit	Value
Number of generated satellites (see note)	-	5
GPS Coarse Time assistance error range	seconds	±1.8
HDOP Range	-	1.8 to 2.5
GPS L1 C/A Signal for Satellite 1, 2 (see note)	dBm	-130
GPS L1 C/A Signal for Satellite 3, 4, 5 (see note)	dBm	LOS signal of -130 dBm, multi-path signal of -136.2 dBm
NOTE: Satellites 1, 2 no multi-path. Satellites 3, 4, 5 multi-path defined in clause 4.2.4.		

**Table 7.4.7: Test parameters Multi-Path scenario - Sub-Tests 2 to 5**

System	Parameters	Unit	Value
	Number of generated satellites per system	-	See Table 6.18
	Total number of generated satellites	-	6
	HDOP Range per system	-	1.4 to 2.1
	Propagation conditions	-	AWGN
	GNSS coarse time assistance error range	seconds	±2
Galileo	Reference signal power level for all satellites	dBm	-127
GPS <sup>(1)</sup>	Reference signal power level for all satellites	dBm	-128.5
GLONASS	Reference signal power level for all satellites	dBm	-131
NOTE 1: "GPS" here means GPS L1 C/A, Modernized GPS, or both, dependent on UE capabilities.			

**Table 6.18: Satellite allocation**

	Satellite allocation for each constellation		
	GNSS 1 <sup>(1)</sup>	GNSS 2 <sup>(1)</sup>	GNSS 3 <sup>(1)</sup>
Single constellation	6	--	--
Dual constellation	3	3	--
Triple constellation	2	2	2
NOTE 1: GNSS refers to global systems i.e., GPS, Galileo, GLONASS			

**Table 7.4.10: Test requirements for Multi-Path scenario**

System	Success rate	2-D position error	Max response time
All	95 %	101.3 m	20.3 s

## 7.5 Moving scenario and periodic update

### 7.5.1 Sub-tests

This test includes sub-tests dependent on the GNSS supported by the UE. Each sub-test is identified by a Sub-Test Number as defined in Table 7.5.1

**Table 7.5.1: Sub-Test Number Definition**

Sub-Test Number	Supported GNSS
1	UE supporting A-GPS L1C/A only
2	UE supporting A-GLONASS only
3	UE supporting A-Galileo only
4	UE supporting A-GPS and Modernized GPS only
5	UE supporting A-GPS and A-GLONASS only

### 7.5.2 Test purpose

To verify the performance when the UE is requested to use periodical reporting with a reporting interval of 2 seconds.

### 7.5.3 Test applicability

This test applies to all types of E-UTRA UE release 9 and forward that supports A-GNSS.

### 7.5.4 Minimum conformance requirements

The position estimates, after the first reported position estimate, shall meet the accuracy requirement in table 7.5.2 or 7.5.3 with the periodical reporting interval of 2 seconds for the parameters specified in table 7.5.4 or 7.5.5.

NOTE: In the actual testing the UE may report error messages until it has been able to acquire GNSS measured results or a position estimate. The SS shall only consider the first measurement report different from an error message as the first position estimate in the requirement in table 7.5.2 or 7.5.3.

**Table 7.5.2: Requirements Moving scenario and periodic update - Sub-Test 1**

Success Rate	2-D position error	Periodical reporting interval
95 %	100 m	2 s

**Table 7.5.3: Requirements Moving scenario and periodic update - Sub-Tests 2 to 5**

Success Rate	2-D position error	Periodical reporting interval
95 %	50 m	2 s

**Table 7.5.4: Parameters Moving scenario and periodic update - Sub-Test 1**

Parameters	Unit	Value
Number of generated satellites	-	5
HDOP Range	-	1.8 to 2.5
Propagation condition	-	AWGN
GPS L1 C/A signal for all satellites	dBm	-130

**Table 7.5.5: Parameters Moving scenario and periodic update - Sub-Tests 2 to 5**

System	Parameters	Unit	Value
	Number of generated satellites per system	-	See Table 7.5.6
	Total number of generated satellites	-	6
	HDOP range	-	1.4 to 2.1
	Propagation conditions	-	AWGN
Galileo	Reference signal power level	dBm	-127
GPS <sup>(1)</sup>	Reference signal power level	dBm	-128.5
GLONASS	Reference signal power level	dBm	-131
NOTE 1: "GPS" here means GPS L1 C/A, Modernized GPS, or both, dependent on UE capabilities.			

**Table 7.5.6: Satellite allocation**

	Satellite allocation for each constellation		
	GNSS 1 <sup>(1)</sup>	GNSS 2 <sup>(1)</sup>	GNSS 3 <sup>(1)</sup>
Single constellation	6	--	--
Dual constellation	3	3	--
Triple constellation	2	2	2
NOTE 1: GNSS refers to global systems i.e., GPS, Galileo, GLONASS			

The normative reference for this requirement is TS 36.171 [3] clause 5.5 and 6.5.

### 7.5.5 Test description

#### 7.5.5.1 Initial conditions

Initial conditions are a set of test configurations the UE needs to be tested in and the steps for the SS to take with the UE to reach the correct measurement state.

Test Environment: Normal, as defined in TS 36.508 [18] clause 4.1.

Frequencies to be tested: Mid Range, as defined in TS 36.508 [18] clause 4.3.1.

Channel Bandwidth to be tested: as defined in TS 36.508 [18] clause 4.3.1

The UE moves on a rectangular trajectory of 940 m by 1 440 m with rounded corner defined in Figure 7.1. The initial reference is first defined followed by acceleration to final speed of 100 km/h in 250 m. The UE then maintains the speed for 400 m. This is followed by deceleration to final speed of 25 km/h in 250 m. The UE then turn 90 degrees with turning radius of 20 m at 25 km/h. This is followed by acceleration to final speed of 100 km/h in 250 m. The sequence is repeated to complete the rectangle.

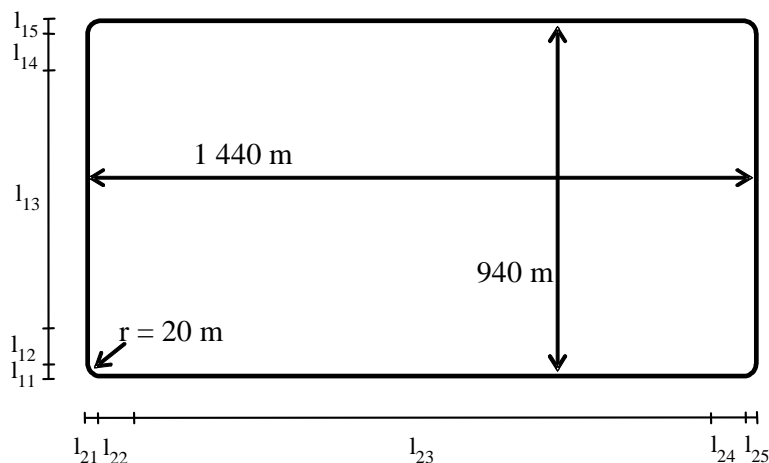

**Figure 7.1: Rectangular trajectory of the moving scenario and periodic update test case**

#### Trajectory Parameters

Parameter	Distance (m)	Speed (km/h)
$l_{11}, l_{15}, l_{21}, l_{25}$	20	25
$l_{12}, l_{14}, l_{22}, l_{24}$	250	25 to 100 and 100 to 25
$l_{13}$	400	100
$l_{23}$	900	100

1. Connect SS and GSS to the UE antenna connector or antenna connectors as shown in Annex A.

2. Set the GPS test parameters as specified in table 7.5.7 or 7.5.8 for GPS scenario #5 in TS 37.571-5 [20].
3. The parameter settings for the cell are set up according to TS 36.508 [18] clause 4.4.3, single cell scenario.
4. Switch on the UE.
5. Establish a signalling connection according to the generic procedure in TS 36.508 [18] clause 4.5.3 (State 3, Generic RB established) on a channel in the Mid EARFCN range.

### 7.5.5.2 Test procedure

1. Start GNSS scenario #5 as specified in clause 6.2.1.2 of TS 37.571-5 [20]
2. Send a RESET UE POSITIONING STORED INFORMATION message.
3. Send an LPP REQUEST CAPABILITIES message.
4. The UE returns an LPP PROVIDE CAPABILITIES message indicating the assistance data supported by the UE in the Assistance Data Support List in the A GNSS Provide Capabilities IE.
5. Send an LPP PROVIDE ASSISTANCE DATA message to provide the assistance data that is supported by the UE as indicated in the step 4 and in accordance with clause 6.2.6 of TS 37.571-5 [20], and with the values defined in clause 6.2.7 of TS 37.571-5 [20]. If the UE message at step 4 includes the ackRequested IE set to TRUE, then the SS shall send an acknowledgment in the LPP PROVIDE ASSISTANCE DATA message.
6. Send an LPP REQUEST LOCATION INFORMATION message to obtain a fix.
7. Ignore any Error messages that the UE may report in LPP PROVIDE LOCATION INFORMATION messages until it has been able to acquire the GNSS signals and reports the first GNSS Measurement Information or Location Information.
8. Discard the first GNSS Measurement Information or Location Information.
9. Record the time of reception of the next LPP PROVIDE LOCATION INFORMATION message after reception of the first GNSS Measurement Information or Location Information.
10. After the reception of the first GNSS Measurement Information or Location Information reported in a LPP PROVIDE LOCATION INFORMATION message, every time the UE returns a GNSS Measurement Information or Location Information in the LPP PROVIDE LOCATION INFORMATION message record the time of reception and the result. If the difference between the time of reception and the time of reception of the previous result is less than 1.5 seconds or greater than 2.5 seconds, or if the UE reports an Error in any LPP PROVIDE LOCATION INFORMATION messages, then record one Bad Result. Otherwise process the result as specified in step 11.
- 10a. If the UE messages at steps 7 to 10 include the ackRequested IE set to TRUE, then the SS shall send LPP acknowledgment messages as required.
11. For UE based testing compare the reported Location Information in the LPP PROVIDE LOCATION INFORMATION message against the simulated position of the UE at the time of applicability reported in the Location Information, and calculate the 2D position error as specified in clause 4.4.2.3. Compare the 2D position error against the value in table 7.5.10 or 7.5.11 and record one Good Result or Bad Result as appropriate; or  
  
For UE assisted testing convert the GNSS Measurement Information reported in the LPP PROVIDE LOCATION INFORMATION message to a 2D position using the method described in clause 4.4.3 and then compare the result against the simulated position of the UE at the time of applicability reported in the GNSS Measurement Information, and calculate the 2D position error as specified in clause 4.4.2.3. Compare the 2D position error against the value in table 7.5.10 or 7.5.11 and record one Good Result or Bad Result as appropriate.
12. If the UE sends the first LPP PROVIDE LOCATION INFORMATION that contains GNSS Measurement Information or Location Information later than 240s after the start of the GNSS scenario, fail the UE and stop the test early. Otherwise collect LPP PROVIDE LOCATION INFORMATION results during 900s, starting from the time recorded in step 9. If at any time the difference between the times of reception of two consecutive results is greater than 240s, fail the UE and stop the test early. Use the collected Good Results and Bad Results to determine the PASS/FAIL according to clause 7.5.6.



13. Release the signalling connection.

### 7.5.5.3 Message contents

Message contents are according to TS 36.508 [18] clauses 4.6 and 4.7 and as follows:

#### RESET UE POSITIONING STORED INFORMATION

Information Element	Value/remark
UE POSITIONING TECHNOLOGY	AGNSS

#### LPP REQUEST CAPABILITIES

Information Element	Value/remark
<i>a-gnss-RequestCapabilities</i>	TRUE

#### LPP REQUEST LOCATION INFORMATION

Information Element	Value/remark	Comment
commonIEsRequestLocationInformation		
> locationInformationType	'locationEstimateRequired' or 'locationMeasurementsRequired'	Depending on test case and UE capabilities, i.e. support for UE-based or UE-assisted
> periodicalReporting		
>> reportingAmount	'ra-Infinity'	Infinite means during the complete test time
>> reportingInterval	'ri0-5'	2 seconds
> additionalInformation	'onlyReturnInformationRequested'	
> qos		
>> horizontalAccuracy (Sub Test 1)	'19' (51.2m)	
>> horizontalAccuracy (Sub Tests 2 to 5)	'13' (24.5m)	
>> verticalCoordinateRequest	FALSE	
>> responseTime	Not present	
<i>a-gnss-RequestLocationInformation</i>		
> gnss-PositioningInstructions		
>> gnssMethods		
>>> gnss-ids	Sub-test 1: 'gps' Sub-test 2: 'glonass' Sub-test 3: 'galileo' Sub-test 4: 'gps' Sub-test 5: 'gps' and 'glonass'	
>> fineTimeAssistanceMeasReq	FALSE	
>> adrMeasReq	FALSE	
>> multiFreqMeasReq	TRUE or FALSE	Depending on UE capabilities
>> assistanceAvailability	FALSE	

### 7.5.6 Test requirement

For the parameters specified in table 7.5.7 or 7.5.8 the UE shall meet the requirements and the success rate specified in table 7.5.10 or 7.5.11 after the first reported position estimates.

- NOTES:
1. In the testing the UE may report error messages until it has been able to acquire GNSS measured results or a position estimate. The test equipment shall only consider the first measurement report different from an error message as the first position estimate in the requirement in table 7.5.10 or 7.5.11.
  2. Due to the statistical nature of the results it is not possible to design a test with predefined confidence level for the success rate in table 7.5.10 or 7.5.11, therefore a simple PASS/FAIL of the results gathered against this success rate is used.

**Table 7.5.7: Test parameters Moving scenario and periodic update - Sub-Test 1**

Parameters	Unit	Value
Number of generated satellites	-	5
HDOP Range	-	1.8 to 2.5
Propagation condition	-	AWGN
GPS L1 C/A Signal for all satellites	dBm	-130

**Table 7.5.8: Test parameters Moving scenario and periodic update - Sub-Tests 2 to 5**

System	Parameters	Unit	Value
	Number of generated satellites per system	-	See Table 7.5.9
	Total number of generated satellites	-	6
	HDOP Range per system	-	1.4 to 2.1
	Propagation conditions	-	AWGN
Galileo	Reference signal power level for all satellites	dBm	-127
GPS <sup>(1)</sup>	Reference signal power level for all satellites	dBm	-128.5
GLONASS	Reference signal power level for all satellites	dBm	-131
NOTE 1: "GPS" here means GPS L1 C/A, Modernized GPS, or both, dependent on UE capabilities.			

**Table 7.5.9: Satellite allocation**

	Satellite allocation for each constellation		
	GNSS 1 <sup>(1)</sup>	GNSS 2 <sup>(1)</sup>	GNSS 3 <sup>(1)</sup>
Single constellation	6	--	--
Dual constellation	3	3	--
Triple constellation	2	2	2
NOTE 1: GNSS refers to global systems i.e., GPS, Galileo, GLONASS			

**Table 7.5.10: Test requirements for Moving scenario and periodic update - Sub-Test 1**

System	Success rate	2-D position error	Periodical reporting interval
All	95 %	101.3 m	Between 1.5 s and 2.5s

**Table 7.5.11: Test requirements for Moving scenario and periodic update - Sub-Tests 2 to 5**

System	Success rate	2-D position error	Periodical reporting interval
All	95 %	51.3 m	Between 1.5 s and 2.5s

## 8 E-UTRA ECID measurement requirements

### 8.1 UE Rx – Tx Time Difference

#### 8.1.1 E-UTRAN FDD UE Rx – Tx time difference case

##### 8.1.1.1 Test purpose

The purpose of this test is to verify that the E-UTRAN FDD UE Rx – Tx time difference measurement accuracy is within the specified limits in TS 36.133 [23] clause 9.1.9.

### 8.1.1.2 Test applicability

This test applies to all types of E-UTRA FDD UE release 9 and forward that supports ECID positioning.

### 8.1.1.3 Minimum conformance requirements

NOTE: This measurement is used for UE positioning purposes.

The UE RX-TX time difference is measured from the serving cell.

The accuracy requirements in Table 8.1.1.3-1 are valid under the following conditions:

Cell specific reference signals are transmitted either from one, two or four antenna ports.

Conditions defined in TS 36.101 [2] clause 7.3 for reference sensitivity are fulfilled.

No changes to the uplink transmission timing are applied during the measurement period.

RSRP<sub>dBm</sub> according to clause E.1 for a corresponding Band.

**Table 8.1.1.3-1: UE Rx – Tx time difference measurement accuracy**

Accuracy	Conditions				
	Es/Iot	Downlink bandwidth	Io <sup>Note 1</sup> range		
dB			MHz	E-UTRA operating bands	Minimum Io dBm/15kHz
±20	≥-3 dB	≤ 3 MHz	1, 4, 6, 10, 11, 18, 19, 21, 23, 24, 33, 34, 35, 36, 37, 38, 39, 40	-121	-50
			9, 42, 43	-120	-50
			28	-119.5	-50
			2, 5, 7, 27, 41, [44]	-119	-50
			26	-118.5 <sup>Note 3</sup>	-50
			3, 8, 12, 13, 14, 17, 20, 22	-118	-50
			25	-117.5	-50
±10	≥-3 dB	≥ 5 MHz	Note 4	Note 4	Note 4

NOTE 1: Io is assumed to have constant EPRE across the bandwidth.  
 NOTE 2: Ts is the basic timing unit defined in TS 36.211 [26].  
 NOTE 3: The condition has the minimum Io of -119 dBm/15kHz when the carrier frequency of the assigned E-UTRA channel bandwidth is within 865-894 MHz.  
 NOTE 4: The same bands and the same Io conditions for each band apply for this requirement as for the corresponding requirement with downlink bandwidth ≤ 3 MHz.

The normative reference for this requirement is TS 36.133 [23] clause 9.1.9 and A.9.7.1.

### 8.1.1.4 Test description

The test consists of two sub-tests; the difference between the sub-tests is the bandwidth, 1.4MHz and 10MHz. Each sub-test has two test points with time delays starting at 32 Ts and 5008 Ts respectively. There is only one active cell in the tests. The tested UE is connected with the serving cell, configured to transmit SRS signals periodically, and signalled to report UE Rx – Tx time difference measurement. The test equipment measures the transmit timing of the UE using the transmitted SRS. The test equipment then compares this timing to the UE Rx-Tx measurement reported by the UE.

#### 8.1.1.4.1 Initial conditions

Test Environment: Normal as defined in TS 36.508 [18] clause 4.1.

Frequencies to be tested: Mid Range, as defined in TS 36.508 [18] clause 4.3.1.1.

Channel Bandwidth to be tested: 1.4 and 10MHz. In the case that 1.4MHz channel bandwidth is not defined for the operating band under test, as defined in TS 36.101 [2] clause 5.6.1, then the corresponding sub-test shall be omitted.

1. Connect the SS (node B emulator) and AWGN noise source to the UE antenna connectors as shown in Annex A figure A.5.

2. Propagation conditions are set according to clause 4.6.2.1.
3. Message contents are defined in clause 8.1.1.4.3.
4. Cell 1 is the serving cell. Cell 1 is the cell used for connection setup with the power levels set according to TS 36.521-3 [25] clauses C.0 and C.1 for this test.

#### 8.1.1.4.2 Test procedure

1. Bring the UE to State 3A or 3A-RF according to TS 36.508 [18] clause 4.5.3A or 5.2A.2, using a value of initial timing advance command  $T_A = 2$  in the Random Access Response which indicates an initial timing advance value  $N_{TA} = 32 T_s$ . Note that in the remainder of the test the timing advance command  $T_A = 31$  which indicates a timing advance adjustment value  $N_{TA} = 0 T_s$ .
2. Set the parameters according to Sub-test 1 in Tables 8.1.1.5-1 and 8.1.1.5-2 as appropriate. Propagation conditions are set according to clause 4.6.2.1.
3. The SS adjusts the downlink timing for Cell 1 to a delay of  $+8 T_s$ , compared to the current value.
4. Wait for 1.6 s to allow for the possibility that the UE makes autonomous timing adjustments.
5. The SS shall transmit an LPP REQUEST LOCATION INFORMATION message, including the *ECID-RequestLocationInformation* IE.
6. The UE shall transmit an LPP PROVIDE LOCATION INFORMATION message including the *ecid-SignalMeasurementInformation* IE.
7. As soon as possible after step 6 the SS shall measure the transmit timing of the UE using the transmitted SRS, relative to the current downlink timing.
8. The SS shall check the reported value of *ue-RxTxTimeDiff* in the *ecid-SignalMeasurementInformation* IE provided by the UE in step 6 and compare it with the value measured in step 7. The SS shall check that the reported value is within the limits specified in table 8.1.1.5-3 for Sub-test 1 compared to the measured value. If the reported value is within the limits the number of successful results for “Sub-test 1 – Test point 1” is increased by one. If the reported value is not within the limits, or the UE reports an error in the LPP PROVIDE LOCATION INFORMATION message in step 6, or does not respond at step 6 within the time given by the *responseTime* IE in the *ECID-RequestLocationInformation* IE in step 5, then the number of unsuccessful results for “Sub-test 1 – Test point 1” is increased by one.
9. Repeat steps 3-8 until the confidence level according to Annex D.4.3 is achieved.  
Note: To avoid a large divergence between the sent TA and the set downlink timing, the SS may reset the downlink timing for Cell 1 to its initial value after a certain amount of loops. The loop during the reset does not count for the result statistics.
10. Repeat steps 1-9 for “Sub-test 1 – Test point 2”. Set a value of initial timing advance command  $T_A = 313$  in the Random Access Response which indicates an initial timing advance value  $N_{TA} = 5008 T_s$  in step 1.
11. Repeat steps 1-10 for Sub-test 2 (consisting of Test point 1 and Test point 2) in Tables 8.1.1.5-1 and 8.1.1.5-2 as appropriate. In step 3 the SS adjusts the downlink timing for Cell 1 to a delay of  $+4 T_s$  compared to the current value.

If both test points of a sub-test pass, the sub-test passes. If one test point of a sub-test fails, the sub-test fails.

If all (applicable) sub-tests pass, the whole test passes. If one (applicable) sub-test fails, the whole test fails.

#### 8.1.1.4.3 Message contents

Message contents are according to TS 36.508 [18] clause 4.6 with the following exceptions:

**Table 8.1.1.4.3-1: SoundingRS-RL-ConfigCommon-DEFAULT: UE Rx – Tx time difference for E-UTRAN FDD test requirement**

Derivation Path: TS 36.508 [18] clause 4.6.3, Table 4.6.3-21 SoundingRS-UL-ConfigCommon-DEFAULT			
Information Element	Value/remark	Comment	Condition
SoundingRS-UL-ConfigCommon-DEFAULT ::= SEQUENCE {			
setup SEQUENCE {			
srs-BandwidthConfig	bw7 for sub-test 1 bw5 for sub-test 2	Set according to specific sub-test	
srs-SubframeConfig	Sc1		FDD
ackNackSRS-SimultaneousTransmission	FALSE		
srsMaxUpPts	Not present		FDD
}			

**Table 8.1.1.4.3-2: SoundingRS-RL-ConfigDedicated-DEFAULT: UE Rx – Tx time difference for E-UTRAN FDD test requirement**

Derivation Path: TS 36.508 [18] clause 4.6.3, Table 4.6.3-22 SoundingRS-UL-ConfigDedicated-DEFAULT			
Information Element	Value/remark	Comment	Condition
SoundingRS-UL-ConfigDedicated-DEFAULT ::= CHOICE {			
setup SEQUENCE {			
srs-Bandwidth	bw0	bw0 used with no frequency hopping. bw3 used with frequency hopping	
srs-HoppingBandwidth	hbw0		
freqDomainPosition	0		
duration	TRUE	Indefinite duration	
srs-ConfigIndex	0		
transmissionComb	0		
cyclicShift	cs0	No cyclic shift	
}			

**Table 8.1.1.4.3-3: ECID-RequestLocationInformation: UE Rx – Tx time difference for E-UTRAN FDD test requirement**

Derivation Path: TS 36.355 clause 6.2			
Information Element	Value/remark	Comment	Condition
LPP-Message ::= SEQUENCE {			
transactionID SEQUENCE {			
Initiator	locationServer		
transactionNumber	1		
}			
endTransaction	FALSE		
sequenceNumber	Not present		
acknowledgement	Not present		
lpp-MessageBody CHOICE {			
c1 CHOICE {			
requestLocationInformation SEQUENCE {			
criticalExtensions CHOICE {			
c1 CHOICE {			
requestLocationInformation-r9 SEQUENCE {			
commonIEsRequestLocationInformation SEQUENCE {			
locationInformationType	locationMeasurementsRequired		
triggeredReporting	Not present		
periodicalReporting	Not present		
additionalInformation	onlyReturnInformationRequested		
qos SEQUENCE {			
horizontalAccuracy	Not present		
verticalCoordinateRequest	FALSE		
verticalAccuracy	Not present		
responseTime	2		
velocityRequest	FALSE		
}			
Environment	Not present		
locationCoordinateTypes	Not present		
velocityTypes	Not present		
}			
a-gnss-RequestLocationInformation	Not present		
otdoa-RequestLocationInformation	Not present		
ecid-RequestLocationInformation ::= SEQUENCE {			
requestedMeasurements	0 0 1	ueRxTxReq	
}			
epdu-RequestLocationInformation	Not Present		
}			
}			
}			
}			
}			
}			
}			
}			
}			

**Table 8.1.1.4.3-4: ECID-ProvideLocationInformation: UE Rx – Tx time difference for E-UTRAN FDD test requirement**

Derivation Path: 36.355 clause 6.2			
Information Element	Value/remark	Comment	Condition
LPP-Message ::= SEQUENCE {			
transactionID SEQUENCE {			
Initiator	locationServer		
transactionNumber	1		
}			
endTransaction	TRUE		
sequenceNumber	(0..255)		
acknowledgement			
lpp-MessageBody CHOICE {			
c1 CHOICE {			
provideLocationInformation SEQUENCE {			
criticalExtensions CHOICE {			
c1 CHOICE {			
provideLocationInformation-r9 SEQUENCE {			
commonIEsProvideLocationInformation	Not present.		
a-gnss-ProvideLocationInformation	Not present		
otdoa-ProvideLocationInformation	Not present		
ecid-ProvideLocationInformation ::= SEQUENCE {			
ecid-SignalMeasurementInformation ::= SEQUENCE {			
primaryCellMeasuredResults	Not Present		
MeasuredResultsList ::= SEQUENCE (SIZE(1..32)) OF MeasuredResultsElement			
MeasuredResultsElement ::= SEQUENCE {			
physCellId			
cellGlobalId			
arfcnEUTRA			
systemFrameNumber			
rsrp-Result	Not Present		
rsrq-Result	Not Present		
ue-RxTxTimeDiff		Set according to specific sub-test and test point.	
}			
}			
}			
epdu-ProvideLocationInformation	Not present		
}			
}			
}			
}			
}			
}			
}			

8.1.1.5 Test requirement

Table 8.1.1.5-1 defines the primary level settings including test tolerances for all sub-tests.

Table 8.1.1.5-1: FDD UE Rx – Tx time difference test parameters

Parameter	Unit	Sub-test 1	Sub-test 2
E-UTRAN RF Channel Number		1	1
$BW_{\text{channel}}$	MHz	1.4	10
DRX		OFF	
PDSCH Reference measurement channel defined in TS 36.521-3 [25] clause A.1.1		R.2 FDD	R.0 FDD
PDSCH allocation	$n_{\text{PRB}}$	2–3	13–36
PDCCH/PCFICH/PHICH Reference measurement channel defined in TS 36.521-3 [25] clause A.2.1		R.8 FDD	R.6 FDD
OCNG Patterns defined in TS 36.521-3 [25] clause D.1.3 (OP.3 FDD) and D.1.1 (OP.1 FDD)		OP.3 FDD	OP.1 FDD
PBCH_RA	dB	0	0
PBCH_RB	dB		
PSS_RA	dB		
SSS_RA	dB		
PCFICH_RB	dB		
PHICH_RA	dB		
PHICH_RB	dB		
PDCCH_RA	dB		
PDCCH_RB	dB		
PDSCH_RA	dB		
PDSCH_RB	dB		
OCNG_RA <sup>NOTE 1</sup>	dB		
OCNG_RB <sup>NOTE 1</sup>	dB		
$N_{oc}$ <sup>Note 2</sup>	dBm/15 kHz		
RSRP <sup>NOTE 3</sup>	dBm/15 kHz	-101	-101
$\hat{E}_s/N_{oc}$	dB	2.7	2.7
$I_o$ <sup>NOTE 3</sup>	dBm/1.08 MHz	-76.55	N/A
	dBm/9 MHz	N/A	-67.35
$\hat{E}_s/I_{ot}$	dB	-2.7	-2.7
Propagation Condition		AWGN	
<p>Note 1: OCNG shall be used such that the resources in the active cell are fully allocated and a constant total transmitted power spectral density is achieved for all OFDM symbols.</p> <p>Note 2: Interference from other cells and noise sources not specified in the test is assumed to be constant over subcarriers and time and shall be modelled as AWGN of appropriate power for <math>N_{oc}</math> to be fulfilled.</p> <p>Note 3: RSRP and <math>I_o</math> levels have been derived from other parameters for information purposes. They are not settable parameters themselves.</p>			

Table 8.1.1.5-2: Sounding Reference Symbol Configuration to be used in FDD UE Rx – Tx time difference test

Field	Sub-test 1	Sub-test 2	Comment
	Value		
srsBandwidthConfiguration	bw7	bw5	
srsSubframeConfiguration	sc1		
ackNackSrsSimultaneousTransmission	FALSE		
srsMaxUpPTS	N/A		Not applicable for FDD
srsBandwidth	0		No hopping
srsHoppingBandwidth	hbw0		
frequencyDomainPosition	0		
Duration	TRUE		Indefinite duration
Srs-ConfigurationIndex	0		SRS periodicity of 2ms.
transmissionComb	0		
cyclicShift	cs0		No cyclic shift
Note: For further information see clause 6.3.2 in 3GPP TS 36.331.			



The UE Rx – Tx time difference measurement accuracy shall fulfil the requirements in Table 8.1.1.5-3.

**Table 8.1.1.5-3: Test requirements UE Rx – Tx time difference measurement accuracy requirements**

	<b>Sub-test 1</b>	<b>Sub-test 2</b>
Lowest reported value	(Measured value from step 7 - 23) $T_s$ converted to RX-TX_TIME_DIFFERENCE according to Table 4.6.3-1	(Measured value from step 7 - 13) $T_s$ converted to RX-TX_TIME_DIFFERENCE according to Table 4.6.3-1
Highest reported value	(Measured value from step 7 + 23) $T_s$ converted to RX-TX_TIME_DIFFERENCE according to Table 4.6.3-1	(Measured value from step 7 + 13) $T_s$ converted to RX-TX_TIME_DIFFERENCE according to Table 4.6.3-1

NOTE: Each sub-test in table 8.1.1.5-3 has two test points starting at  $32 T_s$  and  $5008 T_s$ .

The test tolerances are defined in Annex C.

For the overall test to pass, the ratio of successful reported values in each test point of each sub-test shall be more than 90% with a confidence level of 95%. In the case that 1.4MHz channel bandwidth is not defined for the operating band under test then Sub-test 1 shall be omitted.

## 8.1.2 E-UTRAN TDD UE Rx – Tx time difference case

### 8.1.2.1 Test purpose

The purpose of this test is to verify that the E-UTRAN TDD UE Rx – Tx time difference measurement accuracy is within the specified limits in TS 36.133 [23] clause 9.1.9.

### 8.1.2.2 Test applicability

This test applies to all types of E-UTRA TDD UE release 9 and forward that supports ECID positioning.

### 8.1.2.3 Minimum conformance requirements

NOTE: This measurement is used for UE positioning purposes.

The UE RX-TX time difference is measured from the serving cell.

The accuracy requirements in Table 8.1.1.3-1 are valid under the following conditions:

Cell specific reference signals are transmitted either from one, two or four antenna ports.

Conditions defined in TS 36.101 [2] clause 7.3 for reference sensitivity are fulfilled.

No changes to the uplink transmission timing are applied during the measurement period.

$RSRP_{dBm}$  according to clause E.1 for a corresponding Band.

The normative reference for this requirement is TS 36.133 [23] clause 9.1.9 and A.9.7.1.

### 8.1.2.4 Test description

The test consists of two sub-tests; the difference between the sub-tests is the bandwidth, 1.4MHz and 10MHz. Each sub-test has two test points with time delays starting at  $32 T_s$  and  $5008 T_s$  respectively. There is only one active cell in the tests. The tested UE is connected with the serving cell, configured to transmit SRS signals periodically, and signalled to report UE Rx – Tx time difference measurement. The test equipment measures the transmit timing of the UE using the transmitted SRS. The test equipment then compares this timing to the UE Rx-Tx measurement reported by the UE.

#### 8.1.2.4.1 Initial conditions

Test Environment: Normal as defined in TS 36.508 [18] clause 4.1.

Frequencies to be tested: Mid Range, as defined in TS 36.508 [18] clause 4.3.1.2.

Channel Bandwidth to be tested: 1.4 and 10MHz. In the case that 1.4MHz channel bandwidth is not defined for the operating band under test, as defined in TS 36.101 [2] clause 5.6.1, then the corresponding sub-test shall be omitted.

1. Connect the SS (node B emulator) and AWGN noise source to the UE antenna connectors as shown in Annex A figure A.5.
2. Propagation conditions are set according to clause 4.6.2.1.
3. Message contents are defined in clause 8.1.2.4.3.
4. Cell 1 is the serving cell. Cell 1 is the cell used for connection setup with the power levels set according to TS 36.521-3 [25] clauses C.0 and C.1 for this test.

#### 8.1.2.4.2 Test procedure

1. Bring the UE to State 3A or 3A-RF according to TS 36.508 [18] clause 4.5.3A or 5.2A.2, using a value of initial timing advance command  $T_A = 2$  in the Random Access Response which indicates an initial timing advance value  $N_{TA} = 32 T_s$ . Note that in the remainder of the test the timing advance command  $T_A = 31$  which indicates a timing advance adjustment value  $N_{TA} = 0 T_s$ .
2. Set the parameters according to Sub-test 1 in Tables 8.1.2.5-1 and 8.1.5.2-2 as appropriate. Propagation conditions are set according to clause 4.6.2.1.
3. The SS adjusts the downlink timing for Cell 1 to a delay of  $+8 T_s$ , compared to the current value.
4. Wait for 1.6 s to allow for the possibility that the UE makes autonomous timing adjustments.
5. The SS shall transmit a LPP REQUEST LOCATION INFORMATION message, including the *ECID-RequestLocationInformation* IE.
6. The UE shall transmit an LPP PROVIDE LOCATION INFORMATION message including the *ecid-SignalMeasurementInformation* IE.
7. As soon as possible after step 6 the SS shall measure the transmit timing of the UE using the transmitted SRS, relative to the current downlink timing.
8. The SS shall check the reported value of *ue-RxTxTimeDiff* in the *ecid-SignalMeasurementInformation* IE provided by the UE in step 6 and compare it with the value measured in step 7. The SS shall check that the reported values are within the limits specified in table 8.1.2.5-3 for Sub-test 1 compared to the measured value. If the reported value is within the limits the number of successful results for “Sub-test 1 – Test point 1” is increased by one. If the reported value is not within the limits, or the UE reports an error in the LPP PROVIDE LOCATION INFORMATION message in step 6, or does not respond at step 6 within the time given by the *responseTime* IE in the *ECID-RequestLocationInformation* IE in step 5, then the number of unsuccessful results for “Sub-test 1 – Test point 1” is increased by one.
9. Repeat steps 3-8 until the confidence level according to Annex D.4.3 is achieved.  
Note: To avoid a large divergence between the sent TA and the set downlink timing, the SS may reset the downlink timing for Cell 1 to its initial value after a certain amount of loops. The loop during the reset does not count for the result statistics.
10. Repeat steps 1-9 for “Sub-test 1 – Test point 2”. Set a value of initial timing advance command  $T_A = 313$  in the Random Access Response which indicates an initial timing advance value  $N_{TA} = 5008 T_s$  in step 1.
11. Repeat steps 1-10 for Sub-test 2 (consisting of Test point 1 and Test point 2) in Tables 8.1.2.5-1 and 8.1.2.5-2 as appropriate. In step 3 the SS adjusts the downlink timing for Cell 1 to a delay of  $+4 T_s$  compared to the current value.

If both test points of a sub-test pass, the sub-test passes. If one test point of a sub-test fails, the sub-test fails.

If all (applicable) sub-tests pass, the whole test passes. If one (applicable) sub-test fails, the whole test fails.

#### 8.1.2.4.3 Message contents

Message contents are according to TS 36.508 [18] clause 4.6 with the following exceptions:

**Table 8.1.2.4.3-1: SoundingRS-RL-ConfigCommon-DEFAULT: UE Rx – Tx time difference for E-UTRAN TDD test requirement**

Derivation Path: TS 36.508 [18] clause 4.6.3, Table 4.6.3-21 SoundingRS-UL-ConfigCommon-DEFAULT			
Information Element	Value/remark	Comment	Condition
SoundingRS-UL-ConfigCommon-DEFAULT ::= SEQUENCE {			
setup SEQUENCE {			
srs-BandwidthConfig	bw7 for sub-test 1 bw5 for sub-test 2	Set according to specific sub-test	
srs-SubframeConfig	Sc1		TDD
ackNackSRS-SimultaneousTransmission	FALSE		
srsMaxUpPts	TRUE		TDD
}			

**Table 8.1.2.4.3-2: SoundingRS-RL-ConfigDedicated-DEFAULT: UE Rx – Tx time difference for E-UTRAN TDD test requirement**

Derivation Path: TS 36.508 [18] clause 4.6.3, Table 4.6.3-22 SoundingRS-UL-ConfigDedicated-DEFAULT			
Information Element	Value/remark	Comment	Condition
SoundingRS-UL-ConfigDedicated-DEFAULT ::= CHOICE {			
setup SEQUENCE {			
srs-Bandwidth	bw0	bw0 used with no frequency hopping. bw3 used with frequency hopping	
srs-HoppingBandwidth	hbw0		
freqDomainPosition	0		
duration	TRUE	Indefinite duration	
srs-ConfigIndex	10		
transmissionComb	0		
cyclicShift	cs0	No cyclic shift	
}			

**Table 8.1.2.4.3-3: ECID-RequestLocationInformation: UE Rx – Tx time difference for E-UTRAN TDD test requirement**

Derivation Path: TS 36.355 clause 6.2			
Information Element	Value/remark	Comment	Condition
LPP-Message ::= SEQUENCE {			
transactionID SEQUENCE {			
Initiator	locationServer		
transactionNumber	1		
}			
endTransaction	FALSE		
sequenceNumber	Not present		
acknowledgement	Not present		
lpp-MessageBody CHOICE {			
c1 CHOICE {			
requestLocationInformation SEQUENCE {			
criticalExtensions CHOICE {			
c1 CHOICE {			
requestLocationInformation-r9 SEQUENCE {			
commonIEsRequestLocationInformation SEQUENCE {			
locationInformationType	locationMeasurementsRequired		
triggeredReporting	Not present		
periodicalReporting	Not present		
additionalInformation	onlyReturnInformationRequested		
qos SEQUENCE {			
horizontalAccuracy	Not present		
verticalCoordinateRequest	FALSE		
verticalAccuracy	Not present		
responseTime	2		
velocityRequest	FALSE		
}			
Environment	Not present		
locationCoordinateTypes	Not present		
velocityTypes	Not present		
}			
a-gnss-RequestLocationInformation	Not present		
otdoa-RequestLocationInformation	Not present		
ecid-RequestLocationInformation ::= SEQUENCE {			
requestedMeasurements	0 0 1	ueRXTxReq	
}			
epdu-RequestLocationInformation	Not Present		
}			
}			
}			
}			
}			
}			
}			
}			

**Table 8.1.2.4.3-4: ECID-ProvideLocationInformation: UE Rx – Tx time difference for E-UTRAN TDD test requirement**

Derivation Path: 36.355 clause 6.2			
Information Element	Value/remark	Comment	Condition
LPP-Message ::= SEQUENCE {			
transactionID SEQUENCE {			
initiator	locationServer		
transactionNumber	1		
}			
endTransaction	TRUE		
sequenceNumber	(0..255)		
acknowledgement			
lpp-MessageBody CHOICE {			
c1 CHOICE {			
provideLocationInformation SEQUENCE {			
criticalExtensions CHOICE {			
c1 CHOICE {			
provideLocationInformation-r9 SEQUENCE {			
commonIEsProvideLocationInformation	Not present.		
a-gnss-ProvideLocationInformation	Not present		
otdoa-ProvideLocationInformation	Not present		
ecid-ProvideLocationInformation ::= SEQUENCE {			
ecid-SignalMeasurementInformation ::= SEQUENCE {			
primaryCellMeasuredResults	Not Present		
MeasuredResultsList ::= SEQUENCE (SIZE(1..32)) OF MeasuredResultsElement			
MeasuredResultsElement ::= SEQUENCE {			
physCellId			
cellGlobalId			
arfcnEUTRA			
systemFrameNumber			
rsrp-Result	Not Present		
rsrq-Result	Not Present		
ue-RxTxTimeDiff		Set according to specific sub-test and test point.	
}			
}			
}			
epdu-ProvideLocationInformation	Not present		
}			
}			
}			
}			
}			
}			
}			

### 8.1.2.5 Test requirement

Table 8.1.2.5-1 defines the primary level settings including test tolerances for all sub-tests.

Table 8.1.2.5-1: Cell specific test parameters for UE Rx-Tx time difference measurement

Parameter	Unit	Sub-test 1	Sub-test 2
E-UTRAN RF Channel Number	-	1	1
$BW_{channel}$	MHz	1.4	10
Uplink-downlink configuration of cell <sup>Note 1</sup>		1	1
Special subframe configuration of cell <sup>Note 1</sup>		6	6
PDSCH Reference measurement channel defined in TS 36.521-3 [25] clause A.1.2	-	R.2 TDD	R.0 TDD
PDSCH allocation	$n_{PRB}$	2-3	13-36
PDCCH/PCFICH/PHICH Reference measurement channel defined in TS 36.521-3 [25] clause A.2.1	-	R.8 TDD	R.6 TDD
OCNG Patterns defined in TS 36.521-3 [25] clause D.2.3 (OP.3 TDD) and clause D.2.1 (OP.1 TDD)	-	OP.3 TDD	OP.1 TDD
PBCH_RA	dB	0	0
PBCH_RB	dB		
PSS_RA	dB		
SSS_RA	dB		
PCFICH_RB	dB		
PHICH_RA	dB		
PHICH_RB	dB		
PDCCH_RA	dB		
PDCCH_RB	dB		
PDSCH_RA	dB		
PDSCH_RB	dB		
OCNG_RA <sup>Note 2</sup>	dB		
OCNG_RB <sup>Note 2</sup>	dB		
$N_{oc}$ <sup>Note 3</sup>	dBm/15 kHz		
RSRP <sup>Note 4</sup>	dBm/15 kHz	-100.7	-100.7
$\hat{E}_s/N_{oc}$	dB	-2.7	-2.7
$Io$ <sup>Note 4</sup>	dBm/1.08 MHz	-77.55	N/A
	dBm/9 MHz	N/A	-67.35
$\hat{E}_s/I_{ot}$	dB	-2.7	-2.7
Propagation Condition		AWGN	
Note 1: For special subframe and uplink-downlink configurations see Tables 4.2-1 and 4.2-2 in 3GPP TS 36.211 [26].			
Note 2: OCNG shall be used such that the cell is fully allocated and a constant total transmitted power spectral density is achieved for all OFDM symbols.			
Note 3: Interference from other cells and noise sources not specified in the test is assumed to be constant over subcarriers and time and shall be modelled as AWGN of appropriate power for $N_{oc}$ to be fulfilled.			
Note 4: RSRP and $Io$ levels have been derived from other parameters for information purposes. They are not settable parameters themselves.			

Table 8.1.2.5-2: Sounding Reference Symbol Configuration to be used in TDD UE Rx – Tx time difference test

Field	Sub-test 1	Sub-test 2	Comment
	Value		
srsBandwidthConfiguration	bw7	bw5	
srsSubframeConfiguration	sc1		
ackNackSrsSimultaneousTransmission	FALSE		
srsMaxUpPTS	TRUE		
srsBandwidth	0		No hopping
srsHoppingBandwidth	hbw0		
frequencyDomainPosition	0		
Duration	TRUE		Indefinite duration
Srs-ConfigurationIndex	10		SRS periodicity of 10ms.
transmissionComb	0		
cyclicShift	cs0		No cyclic shift
Note: For further information see clause 6.3.2 in 3GPP TS 36.331.			

The UE Rx – Tx time difference measurement accuracy shall fulfil the requirements in Table 8.1.2.5-3.

**Table 8.1.2.5-3: Test requirements UE Rx – Tx time difference measurement accuracy requirements**

	<b>Sub-test 1</b>	<b>Sub-test 2</b>
Lowest reported value	(Measured value from step 7 - 23) $T_s$ converted to RX-TX_TIME_DIFFERENCE according to Table 4.6.3-1	(Measured value from step 7 - 13) $T_s$ converted to RX-TX_TIME_DIFFERENCE according to Table 4.6.3-1
Highest reported value	(Measured value from step 7 + 23) $T_s$ converted to RX-TX_TIME_DIFFERENCE according to Table 4.6.3-1	(Measured value from step 7 + 13) $T_s$ converted to RX-TX_TIME_DIFFERENCE according to Table 4.6.3-1

NOTE: Each sub-test in table 8.1.2.5-3 has two test points starting at  $32 T_s$  and  $5008 T_s$ .

The test tolerances are defined in Annex C.

For the overall test to pass, the ratio of successful reported values in each test point of each sub-test shall be more than 90% with a confidence level of 95%. In the case that 1.4MHz channel bandwidth is not defined for the operating band under test then Sub-test 1 shall be omitted.

## 9 E-UTRA OTDOA measurement requirements

### 9.1 RSTD Intra-Frequency Measurements

#### 9.1.1 FDD RSTD Measurement Reporting Delay

##### 9.1.1.1 Test purpose

To verify that the RSTD measurement reporting delay meets the requirements in an environment with fading propagation conditions.

##### 9.1.1.2 Test applicability

This test applies to all types of E-UTRA FDD UE release 9 and forward that supports UE-assisted OTDOA.

##### 9.1.1.3 Minimum conformance requirements

When the physical layer cell identities of neighbour cells together with the OTDOA assistance data are provided, the UE shall be able to detect and measure intra-frequency RSTD, specified in 3GPP TS 36.214 [6], for at least  $n=16$  cells, including the reference cell, on the same carrier frequency  $f_1$  as that of the reference cell within

$T_{\text{RSTD IntraFreqFDD, E-UTRAN}}$  ms as given below (see also Figure 9.1.1.3-1):

$$T_{\text{RSTD IntraFreqFDD, E-UTRAN}} = T_{\text{PRS}} \cdot (M - 1) + \Delta \quad \text{ms},$$

where

$T_{\text{RSTD IntraFreqFDD, E-UTRAN}}$  is the total time for detecting and measuring at least  $n$  cells,

$T_{\text{PRS}}$  is the cell-specific positioning subframe configuration period as defined in 3GPP TS 36.211 [26],

$M$  is the number of PRS positioning occasions as defined in Table 9.1.1.3-1, where each PRS positioning occasion comprises of  $N_{\text{PRS}}$  ( $1 \leq N_{\text{PRS}} \leq 6$ ) consecutive downlink positioning subframes defined in 3GPP TS 36.211 [26], and

$\Delta = 160 \cdot \left\lceil \frac{n}{M} \right\rceil$  ms is the measurement time for a single PRS positioning occasion which includes the sampling time and the processing time.

**Table 9.1.1.3-1: Number of PRS positioning occasions within  $T_{\text{RSTD IntraFreqFDD, E-UTRAN}}$**

Positioning subframe configuration period $T_{\text{PRS}}$	Number of PRS positioning occasions $M$
	$f_1$ <small>NOTE 1</small>
160 ms	16
>160 ms	8
Note 1: When only intra-frequency RSTD measurements are performed over cells belonging to the serving FDD carrier frequency $f_1$ .	

The UE physical layer shall be capable of reporting RSTD for the reference cell and all the neighbour cells  $i$  out of at least  $(n-1)$  neighbour cells within  $T_{\text{RSTD IntraFreqFDD, E-UTRAN}}$  provided:

$(\text{PRS } \hat{E}_s / \text{Iot})_{\text{ref}} \geq -6 \text{ dB}$  for all Frequency Bands for the reference cell,  
 $(\text{PRS } \hat{E}_s / \text{Iot})_i \geq -13 \text{ dB}$  for all Frequency Bands for neighbour cell  $i$ ,  
 $(\text{PRS } \hat{E}_s / \text{Iot})_{\text{ref}}$  and  $(\text{PRS } \hat{E}_s / \text{Iot})_i$  conditions apply for all subframes of at least  $L = \frac{M}{2}$  PRS positioning occasions,  
 PRP 1,2<sub>dBm</sub> according to clause E.2 for a corresponding Band.

The time  $T_{\text{RSTD IntraFreqFDD, E-UTRAN}}$  starts from the first subframe of the PRS positioning occasion closest in time after both the OTDOA-RequestLocationInformation message and the OTDOA assistance data in the OTDOA-ProvideAssistanceData message as specified in 3GPP TS 36.355 [4], are delivered to the physical layer of the UE as illustrated in Figure 9.1.1.3-1.

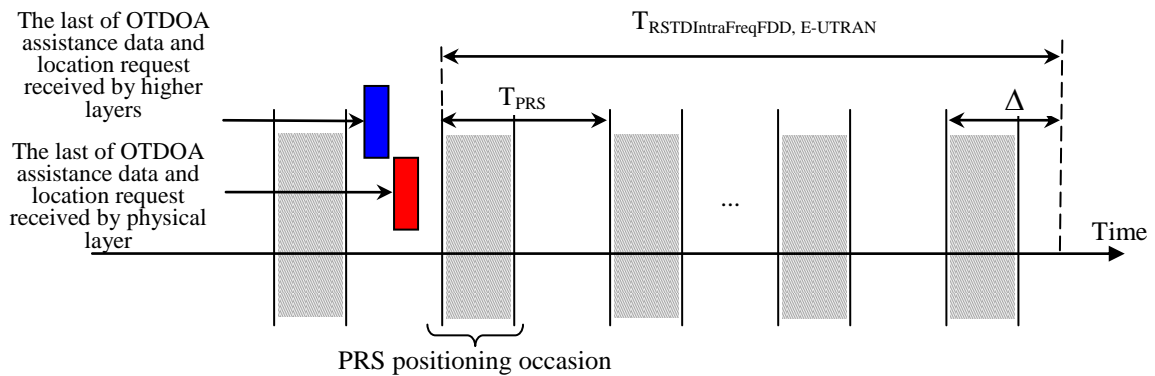

**Figure 9.1.1.3-1: Illustration of the RSTD reporting time requirement in an FDD system**

This requirement assumes that the measurement report is not delayed by other LPP signalling on the DCCH. This measurement reporting delay excludes a delay uncertainty resulted when inserting the measurement report to the TTI of the uplink DCCH. The delay uncertainty is:  $2 \times \text{TTI}_{\text{DCCH}}$ . This measurement reporting delay excludes any delay caused by no UL resources for UE to send the measurement report.

The normative reference for this requirement is TS 36.133 [23] clause 8.1.2.5.1 and A.8.12.1.

**9.1.1.4 Test description**

**9.1.1.4.1 Initial conditions**

Test Environment: Normal; as defined in TS 36.508 [18] clause 4.1.



Frequencies to be tested: Mid Range, as defined in TS 36.508 [18] clause 4.3.1.1.

Channel bandwidth to be tested: 10 MHz as defined in TS 36.508 [18] clause 4.3.1.

1. Connect the SS, faders and AWGN noise sources to the UE antenna connector or antenna connectors as shown in Annex A, Figure A.4.
2. The general test parameter settings are set up according to Table 9.1.1.4.1-1.
3. Propagation conditions are set according to clause 4.7.2.1.
4. Message contents are defined in clause 9.1.1.4.3.
5. In the test there are three synchronized cells: Cell 1, Cell 2 and Cell 3. Cell 1 is the OTDOA assistance data reference as well as the serving cell. Cell 2 and Cell 3 are the neighbour cells. All cells are on the same RF channel. Cell 3 in the test is the Cell 4 defined in clause 4.7.1. The assistance data neighbour cell list includes in total 15 cells, where 13 of the cells are not simulated (dummy cells; as defined in 3GPP TS 37.571-5 clause 7.2.2).
6. The true RSTD (which is the receive time difference for frame 0 between two cells as seen at the UE antenna connector) is set to 0 Ts (0  $\mu$ s) between neighbour Cell 2 and serving Cell 1; and set to 92 Ts (about 3  $\mu$ s) between neighbour Cell 3 and serving Cell 1.

**Table 9.1.1.4.1-1: General test parameters for E-UTRAN FDD intra-frequency RSTD measurement reporting delay under fading propagation conditions**

Parameter	Unit	Value	Comment
Reference cell		Cell 1	Reference cell is the cell in the OTDOA assistance data with respect to which the RSTD measurement is defined, as specified in 3GPP TS 36.214 [6] and 3GPP TS 36.355 [4]. The reference cell is the serving cell in this test case.
Neighbour cells		Cell 2 and Cell 3	Cell 2 and Cell 3 appear at random places in the neighbour cell list in the OTDOA assistance data, but Cell 2 always appears in the first half of the list, whilst Cell 3 appears in the second half of the list.
PCFICH/PDCCH/PHICH parameters		DL Reference Measurement Channel R.6 FDD	As specified in TS 36.521-3 [25] clause A.2.1
Channel Bandwidth ( $BW_{\text{channel}}$ )	MHz	10	
PRS Transmission Bandwidth <sup>Note 2</sup>	RB	50	PRS are transmitted over the system bandwidth
PRS configuration index <sup>Note 2</sup> $I_{\text{PRS}}$		171	This corresponds to periodicity of 320 ms and PRS subframe offset of $I_{\text{PRS}} - 160$ DL subframes, as defined in 3GPP TS 36.211 [26], Table 6.10.4.3-1
Number of consecutive downlink positioning subframes $N_{\text{PRS}}$ <sup>Note 2</sup>		1	As defined in 3GPP TS 36.211 [26]. The number of subframes in a positioning occasion
Physical cell ID PCI <sup>Note 2</sup>		(PCI of Cell 1 – PCI of Cell 2) mod 6 = 0 and (PCI of Cell 1 – PCI of Cell 3) mod 6 = 0	The cell PCIs are selected such that the relative shifts of PRS patterns among cells are as given by the test parameters
CP length <sup>Note 2</sup>		Normal	
DRX		ON	DRX parameters are further specified in Table 9.1.1.4.1-2

Maximum radio frame transmit time offset between the cells at the UE antenna connector <sup>Note 3</sup>	μs	3	Synchronous cells
Expected RSTD <sup>Note 1</sup>	μs	3	The expected RSTD is what is expected at the receiver. The corresponding parameter in the OTDOA assistance data specified in TS 36.355 [4] is the expectedRSTD indicator
Expected RSTD uncertainty <sup>Note 1</sup>	μs	5	The corresponding parameter in the OTDOA assistance data specified in TS 36.355 [4] is the expectedRSTD-Uncertainty index
Number of cells provided in OTDOA assistance data		16	Including the reference cell
PRS muting info <sup>Note 2</sup>		Cell 1: '11110000' Cell 2: '00001111' Cell 3: '11110000'	Corresponds to prs-MutingInfo defined in TS 36.355 [4]
T1	s	3	The length of the time interval from the beginning of each test
T2	s	1.28	The length of the time interval that follows immediately after time interval T1
T3	s	1.28	The length of the time interval that follows immediately after time interval T2
Note 1:	Parameters "Expected RSTD" and "Expected RSTD uncertainty" are not settable parameters. These are parameters signalled in LPP only. For the values to be used in LPP see Table 9.1.1.4.3-5 and TS 37.571-5 [20], clause 7.2.2.		
Note 2:	Parameters "PRS Transmission Bandwidth", "PRS configuration index", "Number of consecutive downlink positioning subframes", "Physical cell ID PCI", "CP length", and "PRS muting info" are settable parameters and also parameters signalled in LPP. The values to be used for "Physical cell ID PCI" are as follows: Cell 1: 0, Cell 2: 6, Cell 3: 12. For all the values to be used in LPP see Table 9.1.1.4.3-5 and TS 37.571-5 [20], clause 7.2.2.		
Note 3:	The parameter "Maximum radio frame transmit time offset between the cells at the UE antenna connector" is not a settable parameter but is used to set the "true RSTD" values in step 6 of clause 9.1.1.4.1.		

**Table 9.1.1.4.1-2: DRX parameters for E-UTRAN FDD intra-frequency RSTD measurement reporting delay under fading propagation conditions**

Field	Value	Comment
onDurationTimer	psf1	As specified in 3GPP TS 36.331 [22], clause 6.3.2
drx-InactivityTimer	psf1	
drx-RetransmissionTimer	sf1	
longDRX-CycleStartOffset	sf320	
shortDRX	Disable	

#### 9.1.1.4.2 Test procedure

The test consists of three consecutive time intervals, with duration of T1, T2 and T3 defined in Table 9.1.1.4.1-1. Cell 1 is active in T1, T2 and T3, whilst Cell 2 and Cell 3 are activated only in the beginning of T2. Cell 2 is active until the end of T3, and Cell 3 is active until the end of T2. The beginning of the time interval T2 shall be aligned 5 ms before the first PRS positioning subframe of a positioning occasion in the reference cell, where 5 ms is the necessary test tolerance. Cell 1 transmits PRS in T2, while Cell 2 transmits PRS only in T3, and Cell 3 transmits PRS only in T2.

NOTE: The information on when PRS is muted is conveyed to the UE using PRS muting information in the OTDOA assistance data.

The OTDOA-RequestLocationInformation message and the OTDOA assistance data as defined in clause 9.1.1.4.3 shall be provided to the UE during T1. The last TTI containing the OTDOA-RequestLocationInformation message shall be

provided to the UE  $\Delta T$  ms before the start of T2, where  $\Delta T = 150$  ms is the maximum processing time of the OTDOA-RequestLocationInformation message and the OTDOA assistance data.

1. Ensure that the UE is in state Generic RB Established State 3A-RF according to 3GPP TS 36.508 [18] clause 7.2A.3.
2. The SS shall send a RESET UE POSITIONING STORED INFORMATION message.
3. Set the parameters according to Table 9.1.1.5-1. Propagation conditions are set according to clause 4.7.2.2 (ETU30).
4. T1 starts.
5. The SS shall transmit an RRCConnectionReconfiguration message with the DRX configuration.
6. The UE shall transmit RRCConnectionReconfigurationComplete message.
7. The SS shall send a LPP PROVIDE ASSISTANCE DATA message, including the *OTDOA-ProvideAssistanceData* IE. The position of neighbour Cell 2 in the *OTDOA-NeighbourCellInfoList* is randomly selected to be in the first 7 elements of the sequence, and the position of neighbour Cell 3 is randomly selected to be in the last 8 elements of the sequence, as described in 3GPP TS 37.571-5 [20], clause 7.2.3..
8. The SS shall send a LPP REQUEST LOCATION INFORMATION message, including the *OTDOA-RequestLocationInformation* IE such that the UE receives the message  $\Delta T$  ms before the start of T2, where  $\Delta T = 150$  ms.
9. When T1 expires, the SS shall switch the power setting from T1 to T2 as specified in Table 9.1.1.5-2.
10. When T2 expires, the SS shall switch the power setting from T2 to T3 as specified in Table 9.1.1.5-2.
11. The UE shall transmit a LPP PROVIDE LOCATION INFORMATION message including the *OTDOA-ProvideLocationInformation* IE within the response time (see clause 4.7.3) specified in clause 9.1.1.5. The UE shall perform and report the RSTD measurements for both Cell 2 and Cell 3 with respect to the reference cell in the OTDOA assistance data, Cell 1. If the UE transmits an *OTDOA-ProvideLocationInformation* IE including the *rstd* field for both Cell 2 and Cell 3 within the response time then the number of successful tests is increased by one. If the UE fails to report the *OTDOA-ProvideLocationInformation* IE with both the *rstd* fields included within the response time then the number of failure tests is increased by one.
12. If the UE message at step 11 includes the *ackRequested* IE set to TRUE, the SS shall send a LPP acknowledgement message.
13. Repeat steps 2-12 until the confidence level according to Annex D is achieved. For each iteration, at step 7 change the random position of the Cells 2 and 3 in the *OTDOA-NeighbourCellInfoList*.

#### 9.1.1.4.3 Message contents

**Table 9.1.1.4.3-1: RESET UE POSITIONING STORED INFORMATION**

Derivation Path: 36.509 clause 6.9			
Information Element	Value/remark	Comment	Condition
UE Positioning Technology	0 0 0 0 0 0 1	OTDOA	

**Table 9.1.1.4.3-2: MAC-MainConfig-RBC: FDD RSTD Measurement Reporting Delay**

Derivation Path: TS 36.508 [18] clause 4.8.2.1.5, Table 4.8.2.1.5-1 MAC-MainConfig-RBC			
Information Element	Value/remark	Comment	Condition
MAC-MainConfig-RBC ::= SEQUENCE {			
drx-Config CHOICE {			
setup SEQUENCE {			
onDurationTimer	psf1		
drx-InactivityTimer	psf1		
drx-RetransmissionTimer	sf1		
longDRX-CycleStartOffset CHOICE {			
sf320	0		
}			
shortDRX	Not present		
}			
}			

Table 9.1.1.4.3-3: LPP RequestLocationInformation

Derivation Path: 36.355 clause 6.2			
Information Element	Value/remark	Comment	Condition
LPP-Message ::= SEQUENCE {			
transactionID SEQUENCE {			
initiator	locationServer		
transactionNumber	1		
}			
endTransaction	FALSE		
sequenceNumber	Not present		
acknowledgement	Not present		
lpp-MessageBody CHOICE {			
c1 CHOICE {			
requestLocationInformation SEQUENCE {			
criticalExtensions CHOICE {			
c1 CHOICE {			
requestLocationInformation-r9 SEQUENCE {			
commonIEsRequestLocationInformation SEQUENCE {			
locationInformationType	locationMeasurementsRequired		
triggeredReporting	Not present		
periodicalReporting	Not present		
additionalInformation	onlyReturnInformationRequested		
qos SEQUENCE {			
horizontalAccuracy	Not present		
verticalCoordinateRequest	FALSE		
verticalAccuracy	Not present		
responseTime	3	See clause 9.1.1.5	
velocityRequest	FALSE		
}			
environment	Not present		
locationCoordinateTypes	Not present		
velocityTypes	Not present		
}			
a-gnss-RequestLocationInformation	Not present		
otdoa-RequestLocationInformation SEQUENCE {			
assistanceAvailability	FALSE		
}			
ecid-RequestLocationInformation	Not present		
epdu-RequestLocationInformation	Not Present		
}			
}			
}			
}			

Table 9.1.1.4.3-4: Void

Table 9.1.1.4.3-5: LPP ProvideAssistanceData

Derivation Path: 36.355 clause 6.2			
Information Element	Value/remark	Comment	Condition
LPP-Message ::= SEQUENCE {			
transactionID SEQUENCE {			
Initiator	locationServer		
transactionNumber	(0..255)		
}			
endTransaction	TRUE		
sequenceNumber	Not present		
acknowledgement	Not present		
lpp-MessageBody CHOICE {			
c1 CHOICE {			
provideAssistanceData SEQUENCE {			
criticalExtensions CHOICE {			
c1 CHOICE {			
provideAssistanceData-r9 SEQUENCE {			
commonIEsProvideAssistanceData	Not present		
a-gnss-ProvideAssistanceData	Not present		
otdoa-ProvideAssistanceData SEQUENCE {			
otdoa-ReferenceCellInfo	As defined in TS 37.571-5 [20], clause 7.2.2.		
otdoa-NeighbourCellInfo	As defined in TS 37.571-5 [20], clause 7.2.2.		
otdoa-Error	Not present		
}			
epdu-ProvideAssistanceData	Not present		
}			
}			
}			
}			

Table 9.1.1.4.3-6: LPP ProvideLocation Information

Derivation Path: 36.355 clause 6.2			
Information Element	Value/remark	Comment	Condition
LPP-Message ::= SEQUENCE {			
transactionID SEQUENCE {			
initiator	locationServer		
transactionNumber	1		
}			
endTransaction	TRUE		
sequenceNumber	(0..255)		
acknowledgement			
lpp-MessageBody CHOICE {			
c1 CHOICE {			
provideLocationInformation SEQUENCE {			
criticalExtensions CHOICE {			
c1 CHOICE {			
provideLocationInformation-r9 SEQUENCE {			
commonEsProvideLocationInformation	Not present.		
a-gnss-ProvideLocationInformation	Not present		
otdoa-ProvideLocationInformation SEQUENCE {			
otdoaSignalMeasurementInformation SEQUENCE {			
systemFrameNumber			
physCellIdRef	Cell 1		
cellGlobalIdRef			
earfcnRef			
referenceQuality			
neighbourMeasurementList SEQUENCE (SIZE(n)) {			
physCellIdNeighbor	Cell 2		
cellGlobalIdNeighbour			
earfcnNeighbour			
rstd	Present		
rstd-Quality			
}			
neighbourMeasurementList SEQUENCE (SIZE(n)) {			
physCellIdNeighbor	Cell 3		
cellGlobalIdNeighbour			
earfcnNeighbour			
rstd	Present		
rstd-Quality			
}			
}			
otdoa-Error	Maybe present with error reason 'undefined' or 'attemptedButUnableToMeasureSomeNeighbourCells'		
}			
ecid-ProvideLocationInformation	Not present		
epdu-ProvideLocationInformation	Not present		
}			
}			
}			
}			
}			
}			

### 9.1.1.5 Test requirement

Table 9.1.1.5-1 and 9.1.1.5-2 define the primary level settings including test tolerances for the test.

**Table 9.1.1.5-1: Cell-specific test parameters for E-UTRAN FDD intra-frequency RSTD measurement reporting delay under fading propagation conditions during T1**

Parameter	Unit	Cell 1	Cell 2	Cell 3
E-UTRA RF Channel Number		1	1	1
OCNG patterns defined in TS 36.521-3 [25] clause D.1.1		OP.5 FDD	N/A	N/A
PBCH_RA	dB	0	N/A	N/A
PBCH_RB				
PSS_RA				
SSS_RA				
PCFICH_RB				
PHICH_RA				
PHICH_RB				
PDCCH_RA				
PDCCH_RB				
OCNG_RA <sup>Note 1</sup>				
OCNG_RB <sup>Note 1</sup>				
$N_{oc}$ <sup>Note 3</sup>	dBm/ 15 kHz	-95		
$PRS \hat{E}_s / N_{oc}$	dB	-Infinity	-Infinity	-Infinity
$Io$ <sup>Note 4</sup>	dBm/ 9 MHz	-64.21	N/A	N/A
$\hat{E}_s / N_{oc}$	dB	0	-Infinity	-Infinity
Propagation Condition		ETU30		
<p>Note 1: OCNG shall be used such that active cell (Cell 1) is fully allocated and a constant total transmitted power spectral density is achieved for all OFDM symbols.</p> <p>Note 2: The resources for uplink transmission are assigned to the UE prior to the start of time period T2.</p> <p>Note 3: Interference from other cells and noise sources not specified in the test are assumed to be constant over subcarriers and time and shall be modelled as AWGN of appropriate power for <math>N_{oc}</math> to be fulfilled.</p> <p>Note 4: <math>Io</math> levels have been derived from other parameters and are given for information purpose. These are not settable test parameters.</p>				



**Table 9.1.1.5-2: Cell-specific test parameters for E-UTRAN FDD intra-frequency RSTD measurement reporting delay under fading propagation conditions during T2 and T3**

Parameter	Unit	Cell 1		Cell 2		Cell 3	
		T2	T3	T2	T3	T2	T3
E-UTRAN Channel Number		1		1		1	
OCNG patterns defined in TS 36.521-3 [25] clause D.1.1		OP.5 FDD		OP.6 FDD		OP.6 FDD	N/A
PBCH_RA	dB	0		0		0	N/A
PBCH_RB							
PSS_RA							
SSS_RA							
PCFICH_RB							
PHICH_RA							
PHICH_RB							
PDCCH_RA							
PDCCH_RB							
OCNG_RA <sup>Note 1</sup>							
OCNG_RB <sup>Note 1</sup>							
PRS_RA	dB	-6	N/A	N/A	0	0	N/A
$N_{oc}$ <sup>Note 3</sup>	dBm/15 kHz	-98	-95	-98	-95	-98	-95
$\hat{E}_s/N_{oc}$	dB	-4	-Infinity	-Infinity	-10	-10	-Infinity
$\hat{E}_s/I_{ot}$ <sup>Note 4</sup>	dB	-4.41	-Infinity	-Infinity	-10	-11.46	-Infinity
$I_o$ <sup>Note 4</sup>	dBm/9 MHz	-69.87	-67.15	-69.87	-67.15	-69.87	N/A
PRP <sup>Note 4</sup>	dBm/15 kHz	-102	-Infinity	-Infinity	-105	-108	-Infinity
RSRP <sup>Note 4</sup>	dBm/15 kHz	-96	-93	-105	-105	-108	-Infinity
$\hat{E}_s/N_{oc}$ <sup>Note 4</sup>	dB	2	2	-7	-10	-10	-Infinity
Propagation Condition		ETU30					
<p>Note 1: OCNG shall be used such that active cells (all, except Cell 3 in T3) are fully allocated and a constant total transmitted power spectral density is achieved for all OFDM symbols other than those in the subframes with transmitted PRS. There is no PDSCH allocated in the subframes with transmitted PRS.</p> <p>Note 2: The resources for uplink transmission are assigned to the UE prior to the start of time period T2.</p> <p>Note 3: Interference from other cells and noise sources not specified in the test are assumed to be constant over subcarriers and time and shall be modelled as AWGN of appropriate power for <math>N_{oc}</math> to be fulfilled.</p> <p>Note 4: If PRS_RA is not "N/A", <math>\hat{E}_s/N_{oc}</math>, <math>\hat{E}_s/I_{ot}</math>, <math>I_o</math>, RSRP and PRP levels have been derived from other parameters and are given for information purpose. If PRS_RA is "N/A", <math>I_o</math> and RSRP levels have been derived from other parameters and are given for information purpose. These are not settable test parameters. Interference conditions shall be applied to all PRS symbols of DL positioning subframes.</p>							

The response time including test tolerance is 3.3 s. The response time is equal to the LPP responseTime IE value plus the test tolerance. The LPP responseTime IE value is derived from the RSTD reporting delay plus  $\Delta T$ , where  $\Delta T = 150$  ms, giving a value of 2710 ms. This is rounded up to the next allowed LPP value of 3 seconds. The RSTD measurement

reporting delay in the test is derived from the following expression,  $T_{PRS}(M-1) + 160 \left\lceil \frac{n}{M} \right\rceil$ , where  $M = 8$  and

$n=16$  are the parameters specified in clause 9.1.1.3 and Table 9.1.1.3-1. This gives the total RSTD reporting delay of 2560 ms for the 15 neighbour cells including Cell 2 and Cell 3 with respect to the reference cell, Cell 1.

The test tolerances are defined in clauses C.1.3 and C4.

The rate of successful tests during repeated tests shall be at least 90% with a confidence level of 95%.

## 9.1.2 TDD RSTD Measurement Reporting Delay

### 9.1.2.1 Test purpose

To verify that the RSTD measurement reporting delay meets the requirements in an environment with fading propagation conditions.

### 9.1.2.2 Test applicability

This test applies to all types of E-UTRA TDD UE release 9 and forward that supports UE-assisted OTDOA.

### 9.1.2.3 Minimum conformance requirements

When the physical layer cell identities of neighbour cells together with the OTDOA assistance data are provided, the UE shall be able to detect and measure intra-frequency RSTD, specified in 3GPP TS 36.214 [6], for at least  $n=16$  cells, including the reference cell, on the same carrier frequency  $f_1$  as that of the reference cell within

$T_{\text{RSTD IntraFreqTDD, E-UTRAN}}$  ms as given below:

$$T_{\text{RSTD IntraFreqTDD, E-UTRAN}} = T_{\text{PRS}} \cdot (M - 1) + \Delta \quad \text{ms},$$

where

$T_{\text{RSTD IntraFreqTDD, E-UTRAN}}$  is the total time for detecting and measuring at least  $n$  cells,

$T_{\text{PRS}}$  is the cell-specific positioning subframe configuration period as defined in 3GPP TS 36.211 [26],

$M$  is the number of PRS positioning occasions as defined in Table 9.1.2.3-1, where each PRS positioning occasion comprises of  $N_{\text{PRS}}$  ( $1 \leq N_{\text{PRS}} \leq 6$ ) consecutive downlink positioning subframes defined in 3GPP TS 36.211 [26], and

$\Delta = 160 \cdot \left\lceil \frac{n}{M} \right\rceil$  ms is the measurement time for a single PRS positioning occasion which includes the sampling time and the processing time.

**Table 9.1.2.3-1: Number of PRS positioning occasions within  $T_{\text{RSTD IntraFreqTDD, E-UTRAN}}$**

Positioning subframe configuration period $T_{\text{PRS}}$	Number of PRS positioning occasions $M$
	$f_1$ <sup>NOTE 1</sup>
160 ms	16
>160 ms	8
Note 1: When only intra-frequency RSTD measurements are performed over cells belonging to the serving FDD carrier frequency $f_1$ .	

The UE physical layer shall be capable of reporting RSTD for the reference cell and all the neighbour cells  $i$  out of at least  $(n-1)$  neighbour cells within  $T_{\text{RSTD IntraFreqTDD, E-UTRAN}}$  provided:

$(\text{PRS } \hat{E}_s / \text{Iot})_{\text{ref}} \geq -6$  dB for all Frequency Bands for the reference cell,

$(\text{PRS } \hat{E}_s / \text{Iot})_i \geq -13$  dB for all Frequency Bands for neighbour cell  $i$ ,

$(\text{PRS } \hat{E}_s / \text{Iot})_{\text{ref}}$  and  $(\text{PRS } \hat{E}_s / \text{Iot})_i$  conditions apply for all subframes of at least  $L = \frac{M}{2}$  PRS positioning occasions,

PRP  $1,2_{dBm}$  according to clause E.2 for a corresponding Band.

The time  $T_{RSTD\ IntraFreqTDD, E-UTRAN}$  starts from the first subframe of the PRS positioning occasion closest in time after both the OTDOA-RequestLocationInformation message and the OTDOA assistance data in the OTDOA-ProvideAssistanceData message as specified in 3GPP TS 36.355 [4], are delivered to the physical layer of the UE.

The requirements shall apply for all TDD special subframe configurations specified in 3GPP TS 36.211 [26] and for the TDD uplink-downlink configurations as specified in Table 9.1.2.3-2.

**Table 9.1.2.3-2: TDD uplink-downlink subframe configurations applicable for TDD intra-frequency requirements**

PRS Transmission Bandwidth [RB]	Applicable TDD uplink-downlink configurations
6, 15	1, 2, 3, 4 and 5
25, 50, 75, 100	0, 1, 2, 3, 4, 5 and 6
Note: Uplink-downlink configurations are specified in Table 4.2-2 in 3GPP TS 36.211 [26].	

This requirement assumes that the measurement report is not delayed by other LPP signalling on the DCCH. This measurement reporting delay excludes a delay uncertainty resulted when inserting the measurement report to the TTI of the uplink DCCH. The delay uncertainty is:  $2 \times TTI_{DCCH}$ . This measurement reporting delay excludes any delay caused by no UL resources for UE to send the measurement report.

The normative reference for this requirement is TS 36.133 [23] clause 8.1.2.5.2 and A.8.12.2.

## 9.1.2.4 Test description

### 9.1.2.4.1 Initial conditions

Test Environment: Normal; as defined in TS 36.508 [18] clause 4.1.

Frequencies to be tested: Mid Range, as defined in TS 36.508 [18] clause 4.3.1.2.

Channel bandwidth to be tested: 10 MHz as defined in TS 36.508 [18] clause 4.3.1.

1. Connect the SS, faders and AWGN noise sources to the UE antenna connector or antenna connectors as shown in Annex A, Figure A.4.
2. The general test parameter settings are set up according to Table 9.1.2.4.1-1.
3. Propagation conditions are set according to clause 4.7.2.1.
4. Message contents are defined in clause 9.1.2.4.3.
5. In the test there are three synchronized cells: Cell 1, Cell 2 and Cell 3. Cell 1 is the OTDOA assistance data reference as well as the serving cell. Cell 2 and Cell 3 are the neighbour cells. All cells are on the same RF channel. Cell 3 in the test is the Cell 4 defined in clause 4.7.1. The assistance data neighbour cell list includes in total 15 cells, where 13 of the cells are not simulated (dummy cells; as defined in 3GPP TS 37.571-5 clause 7.2.2).
6. The true RSTD (which is the receive time difference for frame 0 between two cells as seen at the UE antenna connector) is set to 0 Ts (0  $\mu$ s) between neighbour Cell 2 and serving Cell 1; and set to 92 Ts (about 3  $\mu$ s) between neighbour Cell 3 and serving Cell 1.

**Table 9.1.2.4-1: General test parameters for E-UTRAN TDD intra-frequency RSTD measurement reporting delay under fading propagation conditions**

Parameter	Unit	Value	Comment
Reference cell		Cell 1	Reference is the cell in the OTDOA assistance data with respect to which the RSTD measurement is defined, as specified in 3GPP TS 36.214 [16] and 3GPP TS 36.355 [4]. The reference cell is the serving cell in this test case.
Neighbour cells		Cell 2 and Cell 3	Cell 2 and Cell 3 appear at random places in the neighbour cell list in the OTDOA assistance data, but Cell 2 always appears in the first half of the list, whilst Cell 3 appears in the second half of the list.
PCFICH/PDCCH/PHICH parameters		DL Reference Measurement Channel R.6 TDD	As specified in TS 36.521-3 [25] clause A.2.2
Channel Bandwidth ( $BW_{\text{channel}}$ )	MHz	10	
PRS Transmission Bandwidth <sup>Note 2</sup>	RB	50	PRS are transmitted over the system bandwidth
PRS configuration index $I_{\text{PRS}}$ <sup>Note 2</sup>		174	This corresponds to periodicity of 320 ms and PRS subframe offset of $I_{\text{PRS}} - 160$ DL subframes, as defined in 3GPP TS 36.211 [26], Table 6.10.4.3-1
Number of consecutive downlink positioning subframes $N_{\text{PRS}}$ <sup>Note 2</sup>		1	As defined in 3GPP TS 36.211 [26]. The number of subframes in a positioning occasion
Physical cell ID PCI <sup>Note 2</sup>		(PCI of Cell 1 – PCI of Cell 2) mod 6 = 0 and (PCI of Cell 1 – PCI of Cell 3) mod 6 = 0	The cell PCIs are selected such that the relative shifts of PRS patterns among cells are as given by the test parameters
TDD uplink-downlink configuration		1	As specified in TS 36.211 [26], Section 4.2; corresponds to a configuration with 5 ms switch-point periodicity and two downlink consecutive subframes
TDD special subframe configuration		6	As specified in TS 36.211 [26], Section 4.2; corresponds to DwPTS of $19760 \cdot T_s$ and UpPTS of $4384 \cdot T_s$
CP length <sup>Note 2</sup>		Normal	The same CP length applies for DL and UL
DRX		ON	DRX parameters are further specified in Table 9.1.2.4-2
Maximum radio frame transmit time offset between the cells at the UE antenna connector <sup>Note 3</sup>	$\mu\text{s}$	3	Synchronous cells
Expected RSTD <sup>Note 1</sup>	$\mu\text{s}$	3	The expected RSTD is what is expected at the receiver. The corresponding parameter in the OTDOA assistance data specified in TS 36.355 [4] is the expectedRSTD indicator
Expected RSTD uncertainty <sup>Note 1</sup>	$\mu\text{s}$	5	The corresponding parameter in the OTDOA assistance data specified in TS 36.355 [4] is the expectedRSTD-Uncertainty index
Number of cells provided in OTDOA assistance data		16	Including the reference cell
PRS muting info <sup>Note 2</sup>		Cell 1: '11110000' Cell 2: '00001111' Cell 3: '11110000'	Corresponds to prs-MutingInfo defined in TS 36.355 [4]
T1	s	3	The length of the time interval from the beginning of each test
T2	s	1.28	The length of the time interval that follows immediately after time interval T1

T3	s	1.28	The length of the time interval that follows immediately after time interval T2
Note 1:	Parameters "Expected RSTD" and "Expected RSTD uncertainty" are not settable parameters. These are parameters signalled in LPP only. For the values to be used in LPP see Table 9.1.2.4.3-5 and TS 37.571-5 [20], clause 7.2.2.		
Note 2:	Parameters "PRS Transmission Bandwidth", "PRS configuration index", "Number of consecutive downlink positioning subframes", "Physical cell ID PCI", "CP length", and "PRS muting info" are settable parameters and also parameters signalled in LPP. The values to be used for "Physical cell ID PCI" are as follows: Cell 1: 0, Cell 2: 6, Cell 3: 12. For all the values to be used in LPP see Table 9.1.2.4.3-5 and TS 37.571-5 [20], clause 7.2.2.		
Note 3:	The parameter "Maximum radio frame transmit time offset between the cells at the UE antenna connector" is not a settable parameter but is used to set the "true RSTD" values in step 6 of clause 9.1.2.4.1.		

**Table 9.1.2.4-2: DRX parameters for E-UTRAN TDD intra-frequency RSTD measurement reporting delay under fading propagation conditions**

Field	Value	Comment
onDurationTimer	psf1	As specified in 3GPP TS 36.331 [22], clause 6.3.2.
drx-InactivityTimer	psf1	
drx-RetransmissionTimer	sf1	
longDRX-CycleStartOffset	sf320	
shortDRX	disable	

#### 9.1.2.4.2 Test procedure

The test consists of three consecutive time intervals, with duration of T1, T2 and T3 defined in Table 9.1.2.4-1. Cell 1 is active in T1, T2 and T3, whilst Cell 2 and Cell 3 are activated only in the beginning of T2. Cell 2 is active until the end of T3, and Cell 3 is active until the end of T2. The beginning of the time interval T2 shall be aligned 5 ms before the first PRS positioning subframe of a positioning occasion in the reference cell, where 5 ms is the necessary test tolerance. Cell 1 transmits PRS in T2, while Cell 2 transmits PRS only in T3, and Cell 3 transmits PRS only in T2.

**NOTE:** The information on when PRS is muted is conveyed to the UE using PRS muting information in the OTDOA assistance data.

The OTDOA-RequestLocationInformation message and the OTDOA assistance data as defined in clause 9.1.2.4.3 shall be provided to the UE during T1. The last TTI containing the OTDOA-RequestLocationInformation message shall be provided to the UE  $\Delta T$  ms before the start of T2, where  $\Delta T = 150$  ms is the maximum processing time of the OTDOA-RequestLocationInformation message and the OTDOA assistance data.

1. Ensure that the UE is in state Generic RB Established State 3A-RF according to 3GPP TS 36.508 [18] clause 7.2A.3.
2. The SS shall send a RESET UE POSITIONING STORED INFORMATION message.
3. Set the parameters according to Table 9.1.2.5-1. Propagation conditions are set according to clause 4.7.2.2 (ETU30).
4. T1 starts.
5. The SS shall transmit an RRCConnectionReconfiguration message with the DRX configuration.
6. The UE shall transmit RRCConnectionReconfigurationComplete message.
7. The SS shall send a LPP PROVIDE ASSISTANCE DATA message, including the *OTDOA-ProvideAssistanceData* IE. The position of neighbour Cell 2 in the *OTDOA-NeighbourCellInfoList* is randomly selected to be in the first 7 elements of the sequence, and the position of neighbour Cell 3 is randomly selected to be in the last 8 elements of the sequence, as described in 3GPP TS 37.571-5 [20], clause 7.2.3..
8. The SS shall send a LPP REQUEST LOCATION INFORMATION message, including the *OTDOA-RequestLocationInformation* IE such that the UE receives the message  $\Delta T$  ms before the start of T2, where  $\Delta T = 150$  ms.
9. When T1 expires, the SS shall switch the power setting from T1 to T2 as specified in Table 9.1.2.5-3.

10. When T2 expires, the SS shall switch the power setting from T2 to T3 as specified in Table 9.1.2.5-3.
11. The UE shall transmit a LPP PROVIDE LOCATION INFORMATION including the *OTDOA-ProvideLocationInformation* IE within the response time (see clause 4.7.3) specified in clause 9.1.1.5. The UE shall perform and report the RSTD measurements for both Cell 2 and Cell 3 with respect to the reference cell in the OTDOA assistance data, Cell 1. If the UE transmits an *OTDOA-ProvideLocationInformation* IE including the *rstd* field for both Cell 2 and Cell 3 within the response time then the number of successful tests is increased by one. If the UE fails to report the *OTDOA-ProvideLocationInformation* IE with both the *rstd* fields included within the response time then the number of failure tests is increased by one.
12. If the UE message at step 11 includes the *ackRequested* IE set to TRUE, the SS shall send a LPP acknowledgement message.
13. Repeat steps 2-12 until the confidence level according to Annex D is achieved. For each iteration, at step 9 change the random position of the Cells 2 and 3 in the *OTDOA-NeighbourCellInfoList*.

9.1.2.4.3 Message contents

**Table 9.1.2.4.3-1: RESET UE POSITIONING STORED INFORMATION**

Derivation Path: 36.509 clause 6.9			
Information Element	Value/remark	Comment	Condition
UE Positioning Technology	0 0 0 0 0 0 1	OTDOA	

**Table 9.1.2.4.3-2: MAC-MainConfig-RBC: TDD RSTD Measurement Reporting Delay**

Derivation Path: TS 36.508 [18] clause 4.8.2.1.5, Table 4.8.2.1.5-1 MAC-MainConfig-RBC			
Information Element	Value/remark	Comment	Condition
MAC-MainConfig-RBC ::= SEQUENCE {			
drx-Config CHOICE {			
setup SEQUENCE {			
onDurationTimer	psf1		
drx-InactivityTimer	psf1		
drx-RetransmissionTimer	sf1		
longDRX-CycleStartOffset CHOICE {			
sf320	0		
}			
shortDRX	Not present		
}			
}			

Table 9.1.2.4.3-3: LPP RequestLocationInformation

Derivation Path: 36.355 clause 6.2			
Information Element	Value/remark	Comment	Condition
LPP-Message ::= SEQUENCE {			
transactionID SEQUENCE {			
initiator	locationServer		
transactionNumber	1		
}			
endTransaction	FALSE		
sequenceNumber	Not present		
acknowledgement	Not present		
lpp-MessageBody CHOICE {			
c1 CHOICE {			
requestLocationInformation SEQUENCE {			
criticalExtensions CHOICE {			
c1 CHOICE {			
requestLocationInformation-r9 SEQUENCE {			
commonIEsRequestLocationInformation SEQUENCE {			
locationInformationType	locationMeasurementsRequired		
triggeredReporting	Not present		
periodicalReporting	Not present		
additionalInformation	onlyReturnInformationRequested		
qos SEQUENCE {			
horizontalAccuracy	Not present		
verticalCoordinateRequest	FALSE		
verticalAccuracy	Not present		
responseTime	3	See clause 9.1.2.5	
velocityRequest	FALSE		
}			
environment	Not present		
locationCoordinateTypes	Not present		
velocityTypes	Not present		
}			
a-gnss-RequestLocationInformation	Not present		
otdoa-RequestLocationInformation SEQUENCE {			
assistanceAvailability	FALSE		
}			
ecid-RequestLocationInformation	Not present		
epdu-RequestLocationInformation	Not Present		
}			
}			
}			
}			

Table 9.1.2.4.3-4: Void

Table 9.1.2.4.3-5: LPP ProvideAssistanceData

Derivation Path: 36.355 clause 6.2			
Information Element	Value/remark	Comment	Condition
LPP-Message ::= SEQUENCE {			
transactionID SEQUENCE {			
Initiator	locationServer		
transactionNumber	(0..255)		
}			
endTransaction	TRUE		
sequenceNumber	Not present		
acknowledgement	Not present		
lpp-MessageBody CHOICE {			
c1 CHOICE {			
provideAssistanceData SEQUENCE {			
criticalExtensions CHOICE {			
c1 CHOICE {			
provideAssistanceData-r9 SEQUENCE {			
commonIEsProvideAssistanceData	Not present		
a-gnss-ProvideAssistanceData	Not present		
otdoa-ProvideAssistanceData SEQUENCE {			
otdoa-ReferenceCellInfo	As defined in TS 37.571-5 [20], clause 7.2.2.		
otdoa-NeighbourCellInfo	As defined in TS 37.571-5 [20], clause 7.2.2.		
otdoa-Error	Not present		
}			
epdu-ProvideAssistanceData	Not present		
}			
}			
}			
}			



**Table 9.1.2.4.3-6: LPP ProvideLocation Information**

Derivation Path: 36.355 clause 6.2			
Information Element	Value/remark	Comment	Condition
LPP-Message ::= SEQUENCE {			
transactionID SEQUENCE {			
initiator	locationServer		
transactionNumber	1		
}			
endTransaction	TRUE		
sequenceNumber	(0..255)		
acknowledgement			
lpp-MessageBody CHOICE {			
c1 CHOICE {			
provideLocationInformation SEQUENCE {			
criticalExtensions CHOICE {			
c1 CHOICE {			
provideLocationInformation-r9 SEQUENCE {			
commonEsProvideLocationInformation	Not present.		
a-gnss-ProvideLocationInformation	Not present		
otdoa-ProvideLocationInformation SEQUENCE {			
otdoaSignalMeasurementInformation SEQUENCE {			
systemFrameNumber			
physCellIdRef	Cell 1		
cellGlobalIdRef			
earfcnRef			
referenceQuality			
neighbourMeasurementList SEQUENCE (SIZE(n)) {			
physCellIdNeighbor	Cell 2		
cellGlobalIdNeighbour			
earfcnNeighbour			
rstd	Present		
rstd-Quality			
}			
neighbourMeasurementList SEQUENCE (SIZE(n)) {			
physCellIdNeighbor	Cell 3		
cellGlobalIdNeighbour			
earfcnNeighbour			
rstd	Present		
rstd-Quality			
}			
}			
otdoa-Error	Maybe present with error reason 'undefined' or 'attemptedButUnableToMeasureSomeNeighbourCells'		
}			
ecid-ProvideLocationInformation	Not present		
epdu-ProvideLocationInformation	Not present		
}			
}			
}			
}			
}			
}			

**9.1.2.5 Test requirement**

Table 9.1.2.5-1 and 9.1.2.5-2 define the primary level settings including test tolerances for the test.

**Table 9.1.2.5-1: Cell-specific test parameters for E-UTRAN TDD intra-frequency RSTD measurement reporting delay under fading propagation conditions during T1**

Parameter	Unit	Cell 1	Cell 2	Cell 3
E-UTRA RF Channel Number		1	1	1
OCNG patterns defined in TS 36.521-3 [25] clause D.1.2		OP.1 TDD	N/A	N/A
PBCH_RA	dB	0	N/A	N/A
PBCH_RB				
PSS_RA				
SSS_RA				
PCFICH_RB				
PHICH_RA				
PHICH_RB				
PDCCH_RA				
PDCCH_RB				
OCNG_RA <sup>Note 1</sup>				
OCNG_RB <sup>Note 1</sup>				
PRS_RA				
$N_{oc}$ <sup>Note 3</sup>	dBm/15 kHz	-95		
$\text{PRS } \hat{E}_s/N_{oc}$	dB	-Infinity	-Infinity	-Infinity
$I_o$ <sup>Note 4</sup>	dBm/9 MHz	-64.21	N/A	N/A
$\hat{E}_s/N_{oc}$	dB	0	-Infinity	-Infinity
Propagation Condition		ETU30		
<p>Note 1: OCNG shall be used such that active cell (Cell 1) is fully allocated and a constant total transmitted power spectral density is achieved for all OFDM symbols.</p> <p>Note 2: The resources for uplink transmission are assigned to the UE prior to the start of time period T2.</p> <p>Note 3: Interference from other cells and noise sources not specified in the test are assumed to be constant over subcarriers and time and shall be modelled as AWGN of appropriate power for <math>N_{oc}</math> to be fulfilled.</p> <p>Note 4: <math>I_o</math> levels have been derived from other parameters and are given for information purpose. These are not settable test parameters.</p>				

**Table 9.1.2.5-2: Cell-specific test parameters for E-UTRAN TDD intra-frequency RSTD measurement reporting delay under fading propagation conditions**

Parameter	Unit	Cell 1		Cell 2		Cell 3	
		T2	T3	T2	T3	T2	T3
E-UTRAN Channel Number		1		1		1	
OCNG patterns defined in TS 36.521-3 [25] clause D.2.1		OP.1 TDD		OP.2 TDD		OP.2 TDD	N/A
PBCH_RA	dB	0		0		0	N/A
PBCH_RB							
PSS_RA							
SSS_RA							
PCFICH_RB							
PHICH_RA							
PHICH_RB							
PDCCH_RA							
PDCCH_RB							
OCNG_RA <sup>Note 1</sup>							
OCNG_RB <sup>Note 1</sup>							
PRS_RA	dB	-6	N/A	N/A	0	0	N/A
$N_{oc}$ <sup>Note 3</sup>	dBm/15 kHz	-98	-95	-98	-95	-98	-95
$PRS \hat{E}_s/N_{oc}$	dB	-4	-Infinity	-Infinity	-10	-10	-Infinity
$PRS \hat{E}_s/I_{ot}$ <sup>Note 4</sup>	dB	-4.41	-Infinity	-Infinity	-10	-11.46	-Infinity
$I_o$ <sup>Note 4</sup>	dBm/9 MHz	-69.87	-67.15	-69.87	-67.15	-69.87	N/A
PRP <sup>Note 4</sup>	dBm/15 kHz	-102	-Infinity	-Infinity	-105	-108	-Infinity
RSRP <sup>Note 4</sup>	dBm/15 kHz	-96	-93	-105	-105	-108	-Infinity
$\hat{E}_s/N_{oc}$ <sup>Note 4</sup>	dB	2	2	-7	-10	-10	-Infinity
Propagation Condition		ETU30					
<p>Note 1: OCNG shall be used such that active cells (all, except Cell 3 in T3) are fully allocated and a constant total transmitted power spectral density is achieved for all OFDM symbols other than those in the subframes with transmitted PRS. There is no PDSCH allocated in the subframes with transmitted PRS.</p> <p>Note 2: The resources for uplink transmission are assigned to the UE prior to the start of time period T2.</p> <p>Note 3: Interference from other cells and noise sources not specified in the test are assumed to be constant over subcarriers and time and shall be modelled as AWGN of appropriate power for <math>N_{oc}</math> to be fulfilled.</p> <p>Note 4: If PRS_RA is not "N/A", <math>\hat{E}_s/N_{oc}</math>, <math>PRS \hat{E}_s/I_{ot}</math>, <math>I_o</math>, RSRP and PRP levels have been derived from other parameters and are given for information purpose. If PRS_RA is "N/A", <math>I_o</math> and RSRP levels have been derived from other parameters and are given for information purpose. These are not settable test parameters. Interference conditions shall be applied to all PRS symbols of DL positioning subframes.</p>							

The response time including test tolerance is 3.3 s. The response time is equal to the LPP responseTime IE value plus the test tolerance. The LPP responseTime IE value is derived from the RSTD reporting delay plus  $\Delta T$ , where  $\Delta T = 150$  ms, giving a value of 2710 ms. This is rounded up to the next allowed LPP value of 3 seconds. The RSTD measurement reporting delay in the test is derived from the following expression,  $T_{PRS} (M - 1) + 160 \left\lceil \frac{n}{M} \right\rceil$ , where  $M = 8$  and

$n=16$  are the parameters specified in clause 9.2.1.3 and Table 9.2.1.3-1. This gives the total RSTD reporting delay of 2560 ms for the 15 neighbour cells including Cell 2 and Cell 3 with respect to the reference cell, Cell 1.

The test tolerances are defined in clauses C.1.3 and C4.

The rate of successful tests during repeated tests shall be at least 90% with a confidence level of 95%.

### 9.1.3 FDD RSTD Measurement Accuracy

#### 9.1.3.1 Test purpose

To verify that the RSTD FDD intra-frequency measurement accuracy is within the specified limits.

#### 9.1.3.2 Test applicability

This test applies to all types of E-UTRA FDD UE release 9 and forward that supports UE-assisted OTDOA.

#### 9.1.3.3 Minimum conformance requirements

The accuracy requirements in Table 9.1.3.3-1 are valid under the following conditions:

Conditions defined in TS 36.101 [2] clause 7.3 for reference sensitivity are fulfilled.

PRP  $1,2_{dBm}$  according to clause E.2 for a corresponding Band.

There are no measurement gaps overlapping with the PRS subframes of the measured cell.

The parameter *expectedRSTDUncertainty* signalled over LPP as defined in 3GPP TS 36.355 [4] is less than 5  $\mu$ s.

Table 9.1.3.3-1: RSTD measurement accuracy

Accuracy	Conditions					
	PRS $\hat{\epsilon}_s/\text{lot}$	Minimum PRS bandwidth, which is minimum of serving cell channel bandwidth and the PRS bandwidths of the reference cell and the measured neighbour cell $i$ <sup>Note 6</sup>	Minimum number of available measurement subframes among the reference cell and the measured neighbour cell $i$	Io <sup>Note 8</sup> range		
E-UTRA operating bands				Minimum Io	Maximum Io	
Ts <sup>Note 2</sup>	dB	RB		dBm/15kHz	dBm/BW <sub>Channel</sub>	
±15	(PRS $\hat{\epsilon}_s/\text{lot}$ ) <sub>ref</sub> ≥ -6dB and (PRS $\hat{\epsilon}_s/\text{lot}$ ) <sub>i</sub> ≥ -13dB	≥ 6	6	1, 4, 6, 10, 11, 18, 19, 21, 23, 24, 33, 34, 35, 36, 37, 38, 39, 40	-121	-50
				9, 42, 43	-120	-50
				28	-119.5	-50
				2, 5, 7, 27, 41, [44]	-119	-50
				26	-118.5 <sup>Note 4</sup>	-50
				3, 8, 12, 13, 14, 17, 20, 22	-118	-50
±6	(PRS $\hat{\epsilon}_s/\text{lot}$ ) <sub>ref</sub> ≥ -6dB and (PRS $\hat{\epsilon}_s/\text{lot}$ ) <sub>i</sub> ≥ -13dB	≥ 25	≥ 2	Note 5	Note 5	Note 5
				Note 5	Note 5	Note 5
±5	(PRS $\hat{\epsilon}_s/\text{lot}$ ) <sub>ref</sub> ≥ -6dB and (PRS $\hat{\epsilon}_s/\text{lot}$ ) <sub>i</sub> ≥ -13dB	≥ 50	≥ 1	Note 5	Note 5	Note 5

NOTE 1: This minimum Io condition is expressed as the average Io per RE over all REs in an OFDM symbol.  
NOTE 2: Ts is the basic timing unit defined in TS 36.211 [26].  
NOTE 3: PRS bandwidth is as indicated in *prs-Bandwidth* in the OTDOA assistance data defined in TS 36.355 [4].  
NOTE 4: The condition has the minimum Io of -119 dBm/15kHz when the carrier frequency of the assigned E-UTRA channel bandwidth is within 865-894 MHz.  
NOTE 5: The same bands and the same Io conditions for each band apply for this requirement as for the corresponding requirement with the PRS bandwidth ≥ 6 RB.  
NOTE 6: The serving cell, the reference cell, and the measured neighbour cell  $i$  are on the same carrier frequency.  
NOTE 7: Band 29 is used only for E-UTRA carrier aggregation with other E-UTRA bands.  
NOTE 8: The Io is defined in PRS positioning subframes. The same Io range applies to PRS and non-PRS symbols. Io levels are different in PRS and non-PRS symbols within the same subframe.

The normative reference for this requirement is TS 36.133 [23] clause 9.1.10.1 and A.9.8.1.

### 9.1.3.4 Test description

#### 9.1.3.4.1 Initial conditions

Test Environment: Normal; as defined in TS 36.508 [18] clause 4.1.

Frequencies to be tested: Mid Range, as defined in TS 36.508 [18] clause 4.3.1.1.

Channel bandwidth to be tested: 1.4 MHz (Test 1 and 2) and 10 MHz (Test 3 and 4). In the case that 1.4MHz channel bandwidth is not defined for the operating band under test, as defined in TS 36.101 [2] clause 5.6.1, then this part of the test shall be omitted.

1. Connect the SS and AWGN noise sources to the UE antenna connector or antenna connectors as shown in Annex A, Figure A.3.
  2. The general test parameter settings are set up according to Table 9.1.3.4.1-1.
  3. Propagation conditions are set according to clause 4.7.2.1.
  4. Message contents are defined in clause 9.1.3.4.3.
  5. All cells are on the same carrier frequency. Cell 1 is the serving cell and OTDOA assistance data reference cell; Cell 2 is the neighbour cell. The assistance data neighbour cell list includes in total 15 cells, where 14 of the cells are not simulated (dummy cells; as defined in 3GPP TS 37.571-5 [20], clause 7.2.2).
  6. The true RSTD (which is the receive time difference for frame 0 between the two cells as seen at the UE antenna connector) is set to the following values:
    - Test 1: 92 Ts (2.99  $\mu$ s)
    - Test 2: 0 Ts (0  $\mu$ s)
    - Test 3: 0 Ts (0  $\mu$ s)
    - Test 4: -92 Ts (-2.99  $\mu$ s)
- Note that the related expectedRSTD values to be signalled over LPP are defined in Table 9.1.3.4-1 for each test.

Table 9.1.3.4.1-1: General Test Parameters for intra frequency RSTD Tests for E-UTRAN FDD

Parameter	Unit	Value				Comment
		Test1	Test2	Test3	Test4	
PCFICH/PDCCH/PHICH parameters		R.8 FDD		R.6 FDD		As specified in TS 36.521-3 [25] clause A.2.1
OCNG Patterns defined in TS 36.521-3 [25] clause D.1.1		OP.7 FDD		OP.6 FDD		OCNG shall be used such that both cells are fully allocated and a constant total transmitted power spectral density is achieved for all OFDM symbols (other than those in the PRS subframes). There is no PDSCH allocated in the subframe transmitting PRS.
Reference cell		Cell 1				
Neighbour cell		Cell 2				
E-UTRAN RF Channel Number		1				One FDD carrier frequency is used.
Channel Bandwidth ( $BW_{channel}$ )	MHz	1.4		10		
PRS Transmission Bandwidth Note 2	RB	6		50		
PRS configuration Index $I_{PRS}$ Note 2		2		2		As defined in 3GPP TS 36.211 [26]
Number of consecutive positioning downlink subframes $N_{PRS}$ Note 2		6		1		As defined in 3GPP TS 36.211 [26]
prs-MutingInfo Note 2		Cell 1: '11110000' Cell 2: '11110000'				See section 6.5.1.2 in 3GPP TS 36.355 [4] for more information
Cell ID Note 2		(Cell ID of cell 1 – Cell ID of cell 2) mod 6 = 0	(Cell ID of cell 1 – Cell ID of cell 2) mod 6 = 1	(Cell ID of cell 1 – Cell ID of cell 2) mod 6 = 0	(Cell ID of cell 1 – Cell ID of cell 2) mod 6 = 3	
expectedRSTD Note 1	us	3	0	0	-3	
expectedRSTDUncertainty Note 1	us	5	5	5	5	
CP length Note 2		Normal				
DRX		OFF				
Radio frame transmit time difference between cells (cell 2 TX time – cell 1 TX time) Note 3		3 us				Synchronous cells
Number of cells provided in OTDOA assistance data		16				The number of cells includes the reference cell
$T_{RSTD \text{ IntraFreqFDD, E-UTRAN}}$ Note 4	ms	2560				Derived according to the RSTD measurement requirements specified in Section 9.1.1.3
<p>NOTE 1: Parameters “Expected RSTD” and “Expected RSTD uncertainty” are not settable parameters. These are parameters signalled in LPP only. For the values to be used in LPP see Table 9.1.3.4.3-4 and TS 37.571-5 [20], clause 7.2.2.</p> <p>NOTE 2: Parameters “PRS Transmission Bandwidth”, “PRS configuration index”, “Number of consecutive positioning downlink subframes”, “prs-MutingInfo”, “Cell ID” and “CP length” are settable parameters and also parameters signalled in LPP. The values to be used for “Cell ID” are as follows: Cell 1: 0, Cell 2: Test 1: 6, Test 2: 7, Test 3: 6, Test 4: 9. For all the values to be used in LPP see Table 9.1.3.4.3-4 and TS 37.571-5 [20], clause 7.2.2.</p> <p>NOTE 3: The parameter “Radio frame transmit time difference between cells (cell 2 TX time – cell 1 TX time)” is not a settable parameter but is used to set the “true RSTD” values in step 6 of clause 9.1.3.4.1.</p> <p>NOTE 4: The parameter “<math>T_{RSTD \text{ IntraFreqFDD, E-UTRAN}}</math>” is not a settable parameter but is used to set the LPP “responseTime” value in Table 9.1.3.4.3-2. The value of the LPP responseTime IE is set to <math>T_{RSTD \text{ IntraFreqFDD, E-UTRAN}} + \Delta T</math> ms, where <math>\Delta T = 150</math> ms, giving a value of 2710 ms. This is rounded up to the next allowed LPP value of 3 seconds.</p>						

### 9.1.3.4.2 Test procedure

The test consists of a set-up period and a measurement period. Cell 1 and Cell 2 are both active during the complete test. The beginning of the measurement period shall be aligned with the first PRS positioning subframe of a positioning occasion in the reference cell.

NOTE: The information on when PRS is muted is conveyed to the UE using PRS muting information in the OTDOA assistance data.

The OTDOA-RequestLocationInformation message and the OTDOA assistance data as defined in clause 9.1.3.4.3 shall be provided to the UE during the set-up period. The last TTI containing the OTDOA-RequestLocationInformation message shall be provided to the UE  $\Delta T$  ms before the start of the measurement period, where  $\Delta T = 150$  ms is the maximum processing time of the OTDOA-RequestLocationInformation message and the OTDOA assistance data in the UE.

1. Ensure that the UE is in state Generic RB Established State 3A-RF according to 3GPP TS 36.508 [18] clause 7.2A.3.
2. The SS shall send a RESET UE POSITIONING STORED INFORMATION message.
3. Set the parameters according to Table 9.1.3.5-1 as appropriate. Propagation conditions are set according to clause 4.7.2.1.
4. The SS shall send a LPP PROVIDE ASSISTANCE DATA message, including the *OTDOA-ProvideAssistanceData* IE.
5. The SS shall send a LPP REQUEST LOCATION INFORMATION message, including the *OTDOA-RequestLocationInformation* IE such that the UE receives the message  $\Delta T$  ms before the start of measurement period, where  $\Delta T = 150$  ms.
6. The UE shall transmit a LPP PROVIDE LOCATION INFORMATION message, including the *OTDOA-ProvideLocationInformation* IE.
7. If the UE message at step 6 includes the *ackRequested* IE set to TRUE, the SS shall send a LPP acknowledgement message.
8. The SS shall check the *rstd* value for Cell 2 in the *OTDOA-SignalMeasurementInformation* IE according to Table 9.1.3.5-2.
9. Repeat step 2-8 until the confidence level according to Annex D is achieved.
10. Repeat step 1-9 for each sub-test in Table 9.1.3.5-1 as appropriate.

### 9.1.3.4.3 Message contents

**Table 9.1.3.4.3-1: RESET UE POSITIONING STORED INFORMATION**

Derivation Path: 36.509 clause 6.9			
Information Element	Value/remark	Comment	Condition
UE Positioning Technology	0 0 0 0 0 0 1	OTDOA	



Table 9.1.3.4.3-2: LPP RequestLocationInformation

Derivation Path: 36.355 clause 6.2			
Information Element	Value/remark	Comment	Condition
LPP-Message ::= SEQUENCE {			
transactionID SEQUENCE {			
initiator	locationServer		
transactionNumber	1		
}			
endTransaction	FALSE		
sequenceNumber	Not present		
acknowledgement	Not present		
lpp-MessageBody CHOICE {			
c1 CHOICE {			
requestLocationInformation SEQUENCE {			
criticalExtensions CHOICE {			
c1 CHOICE {			
requestLocationInformation-r9 SEQUENCE {			
commonIEsRequestLocationInformation SEQUENCE {			
locationInformationType	locationMeasurementsRequired		
triggeredReporting	Not present		
periodicalReporting	Not present		
additionalInformation	onlyReturnInformationRequested		
qos SEQUENCE {			
horizontalAccuracy	Not present		
verticalCoordinateRequest	FALSE		
verticalAccuracy	Not present		
responseTime	3	See Note 4 of Table 9.1.3.4.1-1	
velocityRequest	FALSE		
}			
environment	Not present		
locationCoordinateTypes	Not present		
velocityTypes	Not present		
}			
a-gnss-RequestLocationInformation	Not present		
otdoa-RequestLocationInformation SEQUENCE {			
assistanceAvailability	FALSE		
}			
ecid-RequestLocationInformation	Not present		
epdu-RequestLocationInformation	Not Present		
}			
}			
}			
}			

Table 9.1.3.4.3-3: Void

Table 9.1.3.4.3-4: LPP ProvideAssistanceData

Derivation Path: 36.355 clause 6.2			
Information Element	Value/remark	Comment	Condition
LPP-Message ::= SEQUENCE {			
transactionID SEQUENCE {			
Initiator	locationServer		
transactionNumber	(0..255)		
}			
endTransaction	TRUE		
sequenceNumber	Not present		
acknowledgement	Not present		
lpp-MessageBody CHOICE {			
c1 CHOICE {			
provideAssistanceData SEQUENCE {			
criticalExtensions CHOICE {			
c1 CHOICE {			
provideAssistanceData-r9 SEQUENCE {			
commonIEsProvideAssistanceData	Not present		
a-gnss-ProvideAssistanceData	Not present		
otdoa-ProvideAssistanceData SEQUENCE {			
otdoa-ReferenceCellInfo	As defined in TS 37.571-5 [20], clause 7.2.2.		
otdoa-NeighbourCellInfo	As defined in TS 37.571-5 [20], clause 7.2.2.		
otdoa-Error	Not present		
}			
epdu-ProvideAssistanceData	Not present		
}			
}			
}			
}			

Table 9.1.3.4.3-5: LPP ProvideLocation Information

Derivation Path: 36.355 clause 6.2			
Information Element	Value/remark	Comment	Condition
LPP-Message ::= SEQUENCE {			
transactionID SEQUENCE {			
initiator	locationServer		
transactionNumber	1		
}			
endTransaction	TRUE		
sequenceNumber	(0..255)		
acknowledgement			
lpp-MessageBody CHOICE {			
c1 CHOICE {			
provideLocationInformation SEQUENCE {			
criticalExtensions CHOICE {			
c1 CHOICE {			
provideLocationInformation-r9 SEQUENCE {			
commonEsProvideLocationInformation	Not present.		
a-gnss-ProvideLocationInformation	Not present		
otdoa-ProvideLocationInformation			
SEQUENCE {			
otdoaSignalMeasurementInformation			
SEQUENCE {			
systemFrameNumber			
physCellIdRef	Cell 1		
cellGlobalIdRef			
earfcnRef			
referenceQuality			
neighbourMeasurementList			
SEQUENCE (SIZE(1)) {			
physCellIdNeighbor	Cell 2		
cellGlobalIdNeighbour			
earfcnNeighbour			
rstd	Set according to Table 9.1.3.5-2 for each specific test		
rstd-Quality			
}			
}			
otdoa-Error	May be present with error reason 'undefined' or 'attemptedButUnableToMeasureSomeNeighbourCells'		
}			
ecid-ProvideLocationInformation	Not present		
epdu-ProvideLocationInformation	Not present		
}			
}			
}			

### 9.1.3.5 Test requirement

Table 9.1.3.5-1 defines the primary level settings including test tolerances for all tests.

The RSTD FDD intra-frequency accuracy test shall meet the reported values in Table 9.1.3.5-2.

Table 9.1.3.5-1: Cell Specific Test Parameters for intra frequency RSTD Tests for E-UTRAN FDD

Parameter	Unit	Test1		Test2		Test3		Test4	
		Cell1	Cell2	Cell1	Cell2	Cell1	Cell2	Cell1	Cell2
E-UTRAN RF Channel Number		1							
PBCH_RA									
PBCH_RB									
PSS_RA									
SSS_RA									
PCFICH_RB									
PHICH_RA									
PHICH_RB	dB	0	0	0	0	0	0	0	0
PDCCH_RA									
PDCCH_RB									
OCNG_RA <sup>NOTE 1</sup>									
OCNG_RB <sup>NOTE 1</sup>									
PRS_RA	dB	0	0	-2.7	0.3	0	0	-2.7	0.3
$N_{oc}$ <sup>Note 2</sup>	dBm/15 kHz	-98	-98	-98	-98	-98	-98	-98	-98
$\hat{E}_s/N_{oc}$	dB	-2.37	-8.02	-5.7	-12.7	-2.37	-8.02	-5.7	-12.7
$\hat{E}_s/I_{ot}$ <sup>Note 3</sup>	dB	-3	-10	-5.7	-12.7	-3	-10	-5.7	-12.7
$I_o$ <sup>Note 3</sup>	dBm/1.08 MHz	-78.92	-78.92	-79.2	-79.2	N/A	N/A	N/A	N/A
	dBm/9 MHz	N/A	N/A	N/A	N/A	-69.72	-69.72	-69.99	-69.99
PRP <sup>Note 3</sup>	dBm/15kHz	-100.37	-106.02	103.7	110.7	100.37	106.02	103.7	110.7
$\hat{E}_s/N_{oc}$ <sup>Note 3</sup>	dB	-2.37	-8.02	-3	-13	-2.37	-8.02	-3	-13
RSRP <sup>Note 3</sup>	dBm/15kHz	-100.37	-106.02	-101	-111	100.37	106.02	-101	-111
Propagation condition		AWGN							
Note 1:	OCNG shall be used such that both cells are fully allocated and a constant total transmitted power spectral density is achieved for all OFDM symbols (other than those in the PRS subframes). There is no PDSCH allocated in the subframe transmitting PRS.								
Note 2:	Interference from other cells and noise sources not specified in the test is assumed to be constant over subcarriers and time and shall be modelled as AWGN of appropriate power for $N_{oc}$ to be fulfilled.								
Note 3:	$\hat{E}_s/N_{oc}$ , PRS $\hat{E}_s/I_{ot}$ , $I_o$ , RSRP and PRP levels have been derived from other parameters for information purposes. They are not settable parameters themselves. $I_o$ values are derived in the case that there is no PBCH, PSS or SSS in the OFDM symbols carrying PRS.								

Table 9.1.3.5-2: RSTD FDD intra-frequency accuracy requirements for the reported values

	Test 1	Test 2	Test 3	Test 4
Lowest reported value	RSTD_6431	RSTD_6340	RSTD_6350	RSTD_6258
Highest reported value	RSTD_6463	RSTD_6371	RSTD_6361	RSTD_6270

For the overall test to pass, the ratio of successful reported values in each sub-test shall be more than 90% with a confidence level of 95%. In the case that 1.4MHz channel bandwidth is not defined for the operating band under test then Test 1 and Test 2 shall be omitted.

## 9.1.4 TDD RSTD Measurement Accuracy

Editor's note: This test case is incomplete. The following aspects are either missing or not yet determined:

*The PRS Configuration Index for the TDD 1.4 MHz case needs further investigation*

#### 9.1.4.1 Test purpose

To verify that the RSTD TDD intra-frequency measurement accuracy is within the specified limits.

#### 9.1.4.2 Test applicability

This test applies to all types of E-UTRA TDD UE release 9 and forward that supports UE-assisted OTDOA.

#### 9.1.4.3 Minimum conformance requirements

The accuracy requirements in Table 9.1.3.3-1 are valid under the following conditions:

Conditions defined in TS 36.101 [2] clause 7.3 for reference sensitivity are fulfilled.

PRP  $1,2_{dBm}$  according to clause E.2 for a corresponding Band.

There are no measurement gaps overlapping with the PRS subframes of the measured cell.

The parameter *expectedRSTDUncertainty* signalled over LPP as defined in 3GPP TS 36.355 [4] is less than 5  $\mu$ s.

The normative reference for this requirement is TS 36.133 [23] clause 9.1.10.1 and A.9.8.2.

#### 9.1.4.4 Test description

##### 9.1.4.4.1 Initial conditions

Test Environment: Normal; as defined in TS 36.508 [18] clause 4.1.

Frequencies to be tested: Mid Range, as defined in TS 36.508 [18] clause 4.3.1.2.

Channel bandwidth to be tested: 1.4 MHz (Test 1 and 2) and 10 MHz (Test 3 and 4). In the case that 1.4MHz channel bandwidth is not defined for the operating band under test, as defined in TS 36.101 [2] clause 5.6.1, then this part of the test shall be omitted.

1. Connect the SS and AWGN noise sources to the UE antenna connector or antenna connectors as shown in Annex A, Figure A.3.
2. The general test parameter settings are set up according to Table 9.1.4.4.1-1.
3. Propagation conditions are set according to clause 4.7.2.1.
4. Message contents are defined in clause 9.1.4.4.3.
5. All cells are on the same carrier frequency. Cell 1 is the serving cell and OTDOA assistance data reference cell; Cell 2 is the neighbour cell. The assistance data neighbour cell list includes in total 15 cells, where 14 of the cells are not simulated (dummy cells; as defined in 3GPP TS 37.571-5 clause 7.2.2).
6. The true RSTD (which is the receive time difference for frame 0 between the two cells as seen at the UE antenna connector) is set to the following values:
  - Test 1: 92 Ts (2.99  $\mu$ s)
  - Test 2: 0 Ts (0  $\mu$ s)
  - Test 3: 0 Ts (0  $\mu$ s)
  - Test 4: -92 Ts (-2.99  $\mu$ s)

Note that the related *expectedRSTD* values to be signalled over LPP are defined in Table 9.1.4.4-1 for each test.

Table 9.1.4.4.1-1: General Test Parameters for intra frequency RSTD Tests for E-UTRAN TDD

Parameter	Unit	Value				Comment
		Test1	Test2	Test3	Test4	
PCFICH/PDCCH/PHICH parameters		R.8 TDD		R.6 TDD		As specified in TS 36.521-3 [25] clause A.2.2.
OCNG Patterns defined in TS 36.521-3 [25] clause D.1.2		OP.4 TDD		OP.2 TDD		OCNG shall be used such that both cells are fully allocated and a constant total transmitted power spectral density is achieved for all OFDM symbols (other than those in the PRS subframes). There is no PDSCH allocated in the subframe transmitting PRS.
Reference cell		Cell 1				
Neighbour cell		Cell 2				
E-UTRA RF Channel Number		1				One TDD carrier frequency is used.
Channel Bandwidth (BW <sub>channel</sub> )	MHz	1.4		10		
Special subframe configuration		6		6		As specified in table 4.2-1 in TS 36.211 [26]. The same configuration in both cells.
Uplink-downlink configuration		3		1		As specified in table 4.2-2 in TS 36.211 [26] and table 9.1.2.3-2. The same configuration in both cells.
PRS Transmission Bandwidth Note 2	RB	6		50		
PRS configuration Index $I_{PRS}$ Note 2		[9] (Editor's note: TS 36.133 here says "9" but that is not compatible with Uplink-downlink configuration of 3 and $N_{PRS}$ of 6. Suggested value is 5. Further study needed to determine way forward)		14		As defined in 3GPP TS 36.211 [26].
Number of consecutive positioning downlink subframes $N_{PRS}$ Note 2		6		1		As defined in 3GPP TS 36.211 [26].
prs-MutingInfo Note 2		Cell 1: '11110000' Cell 2: '11110000'				See section 6.5.1.2 in 3GPP TS 36.355 [4] for more information
Cell ID Note 2		(Cell ID of cell 1 – Cell ID of cell 2) mod 6 = 0	(Cell ID of cell 1 – Cell ID of cell 2) mod 6 = 1	(Cell ID of cell 1 – Cell ID of cell 2) mod 6 = 0	(Cell ID of cell 1 – Cell ID of cell 2) mod 6 = 3	
expectedRSTD Note 1	us	3	0	0	-3	
expectedRSTDUncertainty Note 1	us	5	5	5	5	
CP length Note 2		Normal				

DRX		OFF	
Radio frame transmit time difference between cells (cell 2 TX time – cell 1 TX time) <sup>Note 3</sup>		3 us	Synchronous cells
Number of cells provided in OTDOA assistance data		16	The number of cells includes the reference cell
$T_{\text{RSTD IntraFreqTDD, E-UTRAN}}$ <sup>Note 4</sup>	ms	2560	Derived according to the RSTD measurement requirements specified in Section 9.1.2.3
<p>NOTE 1: Parameters “Expected RSTD” and “Expected RSTD uncertainty” are not settable parameters. These are parameters signalled in LPP only. For the values to be used in LPP see Table 9.1.4.4.3-4 and TS 37.571-5 [20], clause 7.2.2.</p> <p>NOTE 2: Parameters “PRS Transmission Bandwidth”, “PRS configuration index”, “Number of consecutive positioning downlink subframes”, “prs-MutingInfo”, “Cell ID” and “CP length” are settable parameters and also parameters signalled in LPP. The values to be used for “Cell ID” are as follows: Cell 1: 0, Cell 2: Test 1: 6, Test 2: 7, Test 3: 6, Test 4: 9. For all the values to be used in LPP see Table 9.1.4.4.3-4 and TS 37.571-5 [20], clause 7.2.2.</p> <p>NOTE 3: The parameter “Radio frame transmit time difference between cells (cell 2 TX time – cell 1 TX time)” is not a settable parameter but is used to set the “true RSTD” values in step 6 of clause 9.1.4.4.1.</p> <p>NOTE 4: The parameter “<math>T_{\text{RSTD IntraFreqTDD, E-UTRAN}}</math>” is not a settable parameter but is used to set the LPP “responseTime” value in Table 9.1.4.4.3-2. The value of the LPP responseTime IE is set to <math>T_{\text{RSTD IntraFreqTDD, E-UTRAN}} + \Delta T</math> ms, where <math>\Delta T = 150</math> ms, giving a value of 2710 ms. This is rounded up to the next allowed LPP value of 3 seconds.</p>			

#### 9.1.4.4.2 Test procedure

The test consists of a set-up period and a measurement period. Cell 1 and Cell 2 are both active during the complete test. The beginning of the measurement period shall be aligned with the first PRS positioning subframe of a positioning occasion in the reference cell.

NOTE: The information on when PRS is muted is conveyed to the UE using PRS muting information in the OTDOA assistance data.

The OTDOA-RequestLocationInformation message and the OTDOA assistance data as defined in clause 9.1.4.4.3 shall be provided to the UE during the set-up period. The last TTI containing the OTDOA-RequestLocationInformation message shall be provided to the UE  $\Delta T$  ms before the start of the measurement period, where  $\Delta T = 150$  ms is the maximum processing time of the OTDOA-RequestLocationInformation message and the OTDOA assistance data in the UE.

1. Ensure that the UE is in state Generic RB Established State 3A-RF according to 3GPP TS 36.508 [18] clause 7.2A.3.
2. The SS shall send a RESET UE POSITIONING STORED INFORMATION message.
3. Set the parameters according to Table 9.1.4.5-1 as appropriate. Propagation conditions are set according to clause 4.7.2.1.
4. The SS shall send a LPP PROVIDE ASSISTANCE DATA message, including the *OTDOA-ProvideAssistanceData* IE.
5. The SS shall send a LPP REQUEST LOCATION INFORMATION message, including the *OTDOA-RequestLocationInformation* IE such that the UE receives the message  $\Delta T$  ms before the start of measurement period, where  $\Delta T = 150$  ms.
6. The UE shall transmit a LPP PROVIDE LOCATION INFORMATION message, including the *OTDOA-ProvideLocationInformation* IE.
7. If the UE message at step 6 includes the *ackRequested* IE set to TRUE, the SS shall send a LPP acknowledgement message.
8. The SS shall check the *rstd* value for Cell 2 in the *OTDOA-SignalMeasurementInformation* IE according to Table 9.1.4.5-2.

- 9. Repeat step 2-8 until the confidence level according to Annex D is achieved.
- 10. Repeat step 1-9 for each sub-test in Table 9.1.4.5-1 as appropriate.

9.1.4.4.3 Message contents

**Table 9.1.4.4.3-1: RESET UE POSITIONING STORED INFORMATION**

Derivation Path: 36.509 clause 6.9			
Information Element	Value/remark	Comment	Condition
UE Positioning Technology	0 0 0 0 0 0 1	OTDOA	

**Table 9.1.4.4.3-2: LPP RequestLocationInformation**

Derivation Path: 36.355 clause 6.2			
Information Element	Value/remark	Comment	Condition
LPP-Message ::= SEQUENCE {			
transactionID SEQUENCE {			
initiator	locationServer		
transactionNumber	1		
}			
endTransaction	FALSE		
sequenceNumber	Not present		
acknowledgement	Not present		
lpp-MessageBody CHOICE {			
c1 CHOICE {			
requestLocationInformation SEQUENCE {			
criticalExtensions CHOICE {			
c1 CHOICE {			
requestLocationInformation-r9 SEQUENCE {			
commonIEsRequestLocationInformation SEQUENCE {			
locationInformationType	locationMeasurementsRequired		
triggeredReporting	Not present		
periodicalReporting	Not present		
additionalInformation	onlyReturnInformationRequested		
qos SEQUENCE {			
horizontalAccuracy	Not present		
verticalCoordinateRequest	FALSE		
verticalAccuracy	Not present		
responseTime	3	See Note 4 of Table 9.1.4.4.1-1	
velocityRequest	FALSE		
}			
environment	Not present		
locationCoordinateTypes	Not present		
velocityTypes	Not present		
}			
a-gnss-RequestLocationInformation	Not present		
otdoa-RequestLocationInformation SEQUENCE {			
assistanceAvailability	FALSE		
}			
ecid-RequestLocationInformation	Not present		
epdu-RequestLocationInformation	Not Present		
}			
}			
}			
}			



Table 9.1.4.4.3-3: Void

Table 9.1.4.4.3-4: LPP ProvideAssistanceData

Derivation Path: 36.355 clause 6.2			
Information Element	Value/remark	Comment	Condition
LPP-Message ::= SEQUENCE {			
transactionID SEQUENCE {			
Initiator	locationServer		
transactionNumber	(0..255)		
}			
endTransaction	TRUE		
sequenceNumber	Not present		
acknowledgement	Not present		
lpp-MessageBody CHOICE {			
c1 CHOICE {			
provideAssistanceData SEQUENCE {			
criticalExtensions CHOICE {			
c1 CHOICE {			
provideAssistanceData-r9 SEQUENCE {			
commonIEsProvideAssistanceData	Not present		
a-gnss-ProvideAssistanceData	Not present		
otdoa-ProvideAssistanceData SEQUENCE {			
otdoa-ReferenceCellInfo	As defined in TS 37.571-5 [20], clause7.2.2.		
otdoa-NeighbourCellInfo	As defined in TS 37.571-5 [20], clause7.2.2.		
otdoa-Error	Not present		
}			
epdu-ProvideAssistanceData	Not present		
}			
}			
}			
}			

Table 9.1.4.4.3-5: LPP ProvideLocation Information

Derivation Path: 36.355 clause 6.2			
Information Element	Value/remark	Comment	Condition
LPP-Message ::= SEQUENCE {			
transactionID SEQUENCE {			
initiator	locationServer		
transactionNumber	1		
}			
endTransaction	TRUE		
sequenceNumber	(0..255)		
acknowledgement			
lpp-MessageBody CHOICE {			
c1 CHOICE {			
provideLocationInformation SEQUENCE {			
criticalExtensions CHOICE {			
c1 CHOICE {			
provideLocationInformation-r9 SEQUENCE {			
commonEsProvideLocationInformation	Not present.		
a-gnss-ProvideLocationInformation	Not present		
otdoa-ProvideLocationInformation			
SEQUENCE {			
otdoaSignalMeasurementInformation			
SEQUENCE {			
systemFrameNumber			
physCellIdRef	Cell 1		
cellGlobalIdRef			
earfcnRef			
referenceQuality			
neighbourMeasurementList			
SEQUENCE (SIZE(1)) {			
physCellIdNeighbor	Cell 2		
cellGlobalIdNeighbour			
earfcnNeighbour			
rstd	Set according to Table 9.1.4.5-2 for each specific test		
rstd-Quality			
}			
}			
}			
otdoa-Error	May be present with error reason 'undefined' or 'attemptedButUnableToMeasureSomeNeighbourCells'		
}			
ecid-ProvideLocationInformation	Not present		
epdu-ProvideLocationInformation	Not present		
}			
}			
}			
}			
}			

### 9.1.4.5 Test requirement

Table 9.1.4.5-1 defines the primary level settings including test tolerances for all tests.

Each RSTD TDD intra-frequency accuracy test shall meet the reported values in Table 9.1.4.5-2.

**Table 9.1.4.5-1: Cell Specific Test Parameters for intra frequency RSTD Tests for E-UTRAN TDD**

Parameter	Unit	Test1		Test2		Test3		Test4	
		Cell1	Cell2	Cell1	Cell2	Cell1	Cell2	Cell1	Cell2
E-UTRAN RF Channel Number		1							
PBCH_RA	dB	0	0	0	0	0	0	0	0
PBCH_RB									
PSS_RA									
SSS_RA									
PCFICH_RB									
PHICH_RA									
PHICH_RB									
PDCCH_RA									
PDCCH_RB									
OCNG_RA <sup>Note 1</sup>									
OCNG_RB <sup>Note 1</sup>									
PRS_RA									
$N_{oc}$ <sup>Note 2</sup>	dBm/15 kHz	-98	-98	-98	-98	-98	-98	-98	-98
$\hat{E}_s/N_{oc}$	dB	-2.37	-8.02	-5.7	-12.7	-2.37	-8.02	-5.7	-12.7
$\hat{E}_s/I_{ot}$ <sup>Note 3</sup>	dB	-3	-10	-5.7	-12.7	-3	-10	-5.7	-12.7
$I_o$ <sup>Note 3</sup>	dBm/1.08 MHz	-78.92	-78.92	-79.2	-79.2	N/A	N/A	N/A	N/A
	dBm/9 MHz	N/A	N/A	N/A	N/A	-69.72	-69.72	-69.99	-69.99
PRP <sup>Note 3</sup>	dBm/15kHz	-100.37	-106.02	-103.7	-110.7	-100.37	-106.02	-103.7	-110.7
$\hat{E}_s/N_{oc}$ <sup>Note 3</sup>	dB	-2.37	-8.02	-3	-13	-2.37	-8.02	-3	-13
RSRP <sup>Note 3</sup>	dBm/15kHz	-100.37	-106.02	-101	-111	-100.37	-106.02	-101	-111
Propagation condition		AWGN							
<p>Note 1: OCNG shall be used such that both cells are fully allocated and a constant total transmitted power spectral density is achieved for all OFDM symbols (other than those in the PRS subframes). There is no PDSCH allocated in the subframe transmitting PRS.</p> <p>Note 2: Interference from other cells and noise sources not specified in the test is assumed to be constant over subcarriers and time and shall be modelled as AWGN of appropriate power for <math>N_{oc}</math> to be fulfilled.</p> <p>Note 3: <math>\hat{E}_s/N_{oc}</math>, <math>\hat{E}_s/I_{ot}</math>, <math>I_o</math>, RSRP and PRP levels have been derived from other parameters for information purposes. They are not settable parameters themselves. <math>I_o</math> values are derived in the case that there is no PBCH, PSS or SSS in the OFDM symbols carrying PRS.</p>									

**Table 9.1.4.5-2: RSTD TDD intra-frequency accuracy requirements for the reported values**

	Test 1	Test 2	Test 3	Test 4
Lowest reported value	RSTD_6431	RSTD_6340	RSTD_6350	RSTD_6258
Highest reported value	RSTD_6463	RSTD_6371	RSTD_6361	RSTD_6270

For the overall test to pass, the ratio of successful reported values in each sub-test shall be more than 90% with a confidence level of 95%. In the case that 1.4MHz channel bandwidth is not defined for the operating band under test then Test 1 and Test 2 shall be omitted.

## 9.2 RSTD Inter-Frequency Measurements

### 9.2.1 FDD-FDD inter-frequency RSTD measurement reporting delay

*Editor's note: This test case is incomplete. The following aspects are either missing or not yet determined:*

- *The Test system uncertainties applicable to this test are undefined.*

- The Test tolerances applicable to this test are undefined. Whether inter-frequency RSTD measurement is a mandatory or optional feature

### 9.2.1.1 Test purpose

To verify that the FDD-FDD inter-frequency RSTD measurement reporting delay meets the requirements in an environment with fading propagation conditions.

### 9.2.1.2 Test applicability

This test applies to all types of E-UTRA FDD UE release 10 and forward. Other possible applicability is FFS

### 9.2.1.3 Minimum conformance requirements

When the physical layer cell identities of neighbour cells together with the OTDOA assistance data are provided, the UE shall be able to detect and measure inter-frequency RSTD, specified in 3GPP TS 36.214 [6], for at least  $n=16$  cells, including the reference cell, within  $T_{\text{RSTD InterFreqFDD, E-UTRAN}}$  ms as given below:

$$T_{\text{RSTD InterFreqFDD, E-UTRAN}} = T_{\text{PRS}} \cdot (M - 1) + \Delta \quad \text{ms},$$

where

$T_{\text{RSTD InterFreqFDD, E-UTRAN}}$  is the total time for detecting and measuring at least  $n$  cells,

$T_{\text{PRS}}$  is the largest value of the cell-specific positioning subframe configuration period, defined in 3GPP TS 36.211 [26], among the measured  $n$  cells including the reference cell,

$M$  is the number of PRS positioning occasions as defined in Table 9.2.1.3-1, where each PRS positioning occasion comprises of  $N_{\text{PRS}}$  ( $1 \leq N_{\text{PRS}} \leq 6$ ) consecutive downlink positioning subframes defined in 3GPP TS 36.211 [26], and

$\Delta = 160 \cdot \left\lceil \frac{n}{M} \right\rceil$  ms is the measurement time for a single PRS positioning occasion which includes the sampling time and the processing time.

**Table 9.2.1.3-1: Number of PRS positioning occasions within  $T_{\text{RSTD InterFreqFDD, E-UTRAN}}$**

Positioning subframe configuration period $T_{\text{PRS}}$	Number of PRS positioning occasions $M$	
	$f2$ <sup>Note 1</sup>	$f1$ and $f2$ <sup>Note 2</sup>
160 ms	16	32
>160 ms	8	16
Note 1: When inter-frequency RSTD measurements are performed over the reference cell and neighbour cells, which belong to the FDD inter-frequency carrier frequency $f2$ . Note 2: When inter-frequency RSTD measurements are performed over the reference cell and the neighbour cells, which belong to the serving FDD carrier frequency $f1$ and the FDD inter-frequency carrier frequency $f2$ respectively.		

The UE physical layer shall be capable of reporting RSTD for the reference cell and all the neighbour cells  $i$  out of at least  $(n-1)$  neighbour cells within  $T_{\text{RSTD InterFreqFDD, E-UTRAN}}$  provided:

$$\left( \text{PRS } \hat{E}_s / \text{Iot} \right)_{\text{ref}} \geq -6 \text{ dB for all Frequency Bands for the reference cell,}$$

$$\left( \text{PRS } \hat{E}_s / \text{Iot} \right)_i \geq -13 \text{ dB for all Frequency Bands for neighbour cell } i,$$

$(\text{PRS } \hat{E}_s / \text{Iot})_{ref}$  and  $(\text{PRS } \hat{E}_s / \text{Iot})_t$  conditions apply for all subframes of at least  $L = \frac{M}{2}$  PRS positioning occasions,

PRP 1,2<sub>dBm</sub> according to E.3 for a corresponding Band.

$\text{PRS } \hat{E}_s / \text{Iot}$  is as defined in Section 9.1.1.3.

The time  $T_{\text{RSTD InterFreqFDD, E-UTRAN}}$  starts from the first subframe of the PRS positioning occasion closest in time after both the OTDOA-RequestLocationInformation message and the OTDOA assistance data in the OTDOA-ProvideAssistanceData message as specified in 3GPP TS 36.355 [4], are delivered to the physical layer of the UE.

This requirement assumes that the measurement report is not delayed by other LPP signalling on the DCCH. This measurement reporting delay excludes a delay uncertainty resulted when inserting the measurement report to the TTI of the uplink DCCH. The delay uncertainty is:  $2 \times \text{TTI}_{\text{DCCH}}$ . This measurement reporting delay excludes any delay caused by no UL resources for UE to send the measurement report.

The normative reference for this requirement is TS 36.133 [23] clause 8.1.2.6.1 and A.8.13.1.

## 9.2.1.4 Test description

### 9.2.1.4.1 Initial conditions

Test Environment: Normal; as defined in TS 36.508 [18] clause 4.1.

Frequencies to be tested: Mid Range, as defined in TS 36.508 [18] clause 4.3.1.1.

Channel bandwidth to be tested: 10 MHz as defined in TS 36.508 [18] clause 4.3.1.

1. Connect the SS, faders and AWGN noise sources to the UE antenna connector or antenna connectors as shown in Annex A, Figure A.4.
2. The general test parameter settings are set up according to Table 9.2.1.4.1-1.
3. Propagation conditions are set according to clause 4.7.2.1.
4. Message contents are defined in clause 9.2.1.4.3.
5. In the test there are three synchronized cells: Cell 1, Cell 2 and Cell 3. Cell 1 is the OTDOA assistance data reference as well as the serving cell. Cell 2 and Cell 3 are the neighbour cells. Cell 1 is on FDD RF channel 1. Cell 2 and Cell 3 are on a FDD RF channel 2. The assistance data neighbour cell list includes in total 15 cells, where 13 of the cells are not simulated (dummy cells; as defined in 3GPP TS 37.571-5 clause 7.2.2).
6. The true RSTD (which is the receive time difference for frame 0 between two cells as seen at the UE antenna connector) is set to 0 Ts (0  $\mu$ s) between neighbour Cell 2 and serving Cell 1; and set to 92 Ts (about 3  $\mu$ s) between neighbour Cell 3 and serving Cell 1.
7. The gap pattern configuration # 0 as defined in Table 8.1.2.1-1 in 3GPP TS 36.133 [23] is configured and does not overlap with PRS subframes of Cell 1.

**Table 9.2.1.4.1-1: General test parameters for E-UTRAN FDD-FDD inter-frequency RSTD measurement reporting delay under fading propagation conditions**

Parameter	Unit	Value	Comment
Reference cell		Cell 1	Reference cell is the cell with respect to which the RSTD measurement is defined, as specified in 3GPP TS 36.214 [6] and 3GPP TS 36.355 [4]. The reference cell is the serving cell on RF channel 1 in this test case.
Neighbour cells		Cell 2 and Cell 3	Cells on RF channel 2. The cells appear at random places in the neighbour cell list in the OTDOA assistance data, but Cell 2 always appears in the first half of the list, whilst Cell 3 appears in the second half of the list.
PCFICH/PDCCH/PHICH parameters		DL Reference Measurement Channel R.6 FDD	As specified in TS 36.521-3 [25] clause A.2.1
Channel Bandwidth ( $BW_{\text{channel}}$ )	MHz	10	
PRS Bandwidth <sup>Note 2</sup>	RB	50	PRS are transmitted over the system bandwidth
Gap pattern Id		0	As specified in Table 8.1.2.1-1 in TS 36.133[23].
Gap offset		9	As specified in 36.331 [22], Section 6.3.5
PRS configuration index $I_{\text{PRS}}$ <sup>Note 2</sup>		Cell 1: 181, Cell 2, Cell 3: 171	This corresponds to periodicity of 320 ms and PRS subframe offset of $I_{\text{PRS}} - 160$ DL subframes, as defined in 3GPP TS 36.211 [26], Table 6.10.4.3-1
Number of consecutive downlink positioning subframes $N_{\text{PRS}}$ <sup>Note 2</sup>		1	As defined in TS 36.211 [26]. The number of subframes in a positioning occasion
Physical cell ID PCI <sup>Note 2</sup>		(PCI of Cell 1 – PCI of Cell 2)mod6=0 and (PCI of Cell 1 – PCI of Cell 3)mod6=0	The cell PCIs are selected such that the relative shifts of PRS patterns among cells are as given by the test parameters
CP length <sup>Note 2</sup>		Normal	
DRX		ON	DRX parameters are further specified in Table 9.2.1.4.1-2
prs-SubframeOffset <sup>Note 2</sup>		310	Number of subframes rounded to the closest integer. The corresponding parameter in the OTDOA assistance data is prs-SubframeOffset specified in TS 36.355 [4]
slotNumberOffset <sup>Note 2</sup>		0	The slot number offset at the transmitter between a neighbour cell and the assistance data reference cell specified in TS 36.355 [4]
Maximum subframe shift between the cells at the UE antenna connector <sup>Note 3</sup>	μs	3	Synchronous cells
Expected RSTD <sup>Note 1</sup>	μs	3	The expected RSTD is what is expected at the receiver. The corresponding parameter in the OTDOA assistance data specified in TS 36.355 [4] is the expectedRSTD indicator

Expected RSTD uncertainty <sup>Note 1</sup>	µs	5	The corresponding parameter in the OTDOA assistance data specified in TS 36.355 [4] is the expectedRSTD-Uncertainty index
Number of cells provided in OTDOA assistance data		16	The list includes the reference cell (received in <i>OTDOA-ReferenceCellInfo</i> [4]) on RF channel 1 and 15 other cells on RF channel 2, all received in <i>OTDOA-ProvideAssistanceData</i> [4].
PRS muting info <sup>Note 2</sup>		Cell 1: '1111111100000000' Cell 2: '0000000011111111' Cell 3: '1111111100000000'	Corresponds to prs-MutingInfo defined in TS 36.355 [4]
T1	s	3	The length of the time interval from the beginning of each test
T2	s	2.48	The length of the time interval that follows immediately after time interval T1
T3	s	2.48	The length of the time interval that follows immediately after time interval T2
<p>Note 1: Parameters "Expected RSTD" and "Expected RSTD uncertainty" are not settable parameters. These are parameters signalled in LPP only. For the values to be used in LPP see Table 9.2.1.4.3-5 and TS 37.571-5 [20], clause 7.2.2.</p> <p>Note 2: Parameters "PRS Bandwidth", "PRS configuration index", "Number of consecutive downlink positioning subframes", "Physical cell ID PCI", "CP length", "prs-SubframeOffset", "slotNumberOffset" and "PRS muting info" are settable parameters and also parameters signalled in LPP. The values to be used for "Physical cell ID PCI" are as follows: Cell 1: 0, Cell 2: 6, Cell 3: 12. For all the values to be used in LPP see Table 9.2.1.4.3-5 and TS 37.571-5 [20], clause 7.2.2.</p> <p>Note 3: The parameter "Maximum subframe shift between the cells at the UE antenna connector" is not a settable parameter but is used to set the "true RSTD" values in step 6 of clause 9.2.1.4.1.</p>			

**Table 9.2.1.4.1-2: DRX parameters for E-UTRAN FDD-FDD inter-frequency RSTD measurement reporting delay under fading propagation conditions**

Field	Value	Comment
onDurationTimer	psf1	As specified in 3GPP TS 36.331 [22], clause 6.3.2
drx-InactivityTimer	psf1	
drx-RetransmissionTimer	sf1	
longDRX-CycleStartOffset	sf320	
shortDRX	Disable	

#### 9.2.1.4.2 Test procedure

The test consists of three consecutive time intervals, with duration of T1, T2 and T3 defined in Table 9.2.1.4.1-1. Cell 1 is active in T1, T2 and T3, whilst Cell 2 and Cell 3 are activated only in the beginning of T2. Cell 2 is active until the end of T3, and Cell 3 is active until the end of T2. The beginning of the time interval T2 shall be aligned [5] ms before the first PRS positioning subframe of a positioning occasion in the reference cell, where [5] ms is the necessary test tolerance. Cell 1 transmits PRS only in T2, Cell 2 transmits PRS only in T3, and Cell 3 transmits PRS only in T2.

NOTE: The information on when PRS is muted is conveyed to the UE using PRS muting information in the OTDOA assistance data.

The OTDOA-RequestLocationInformation message and the OTDOA assistance data as defined in clause 9.2.1.4.3 shall be provided to the UE during T1. The last TTI containing the OTDOA-RequestLocationInformation message shall be provided to the UE  $\Delta T$  ms before the start of T2, where  $\Delta T = 150$  ms is the maximum processing time of the OTDOA-RequestLocationInformation message and the OTDOA assistance data.

1. Ensure that the UE is in state Generic RB Established State 3A-RF according to 3GPP TS 36.508 [18] clause 7.2A.3.
2. The SS shall send a RESET UE POSITIONING STORED INFORMATION message.

3. Set the parameters according to Table 9.2.1.5-1. Propagation conditions are set according to clause 4.7.2.2 (ETU30).
4. T1 starts.
5. The SS shall transmit an RRCConnectionReconfiguration message with the DRX configuration and the measurement gap configuration.
6. The UE shall transmit RRCConnectionReconfigurationComplete message.
7. The SS shall send a LPP PROVIDE ASSISTANCE DATA message, including the *OTDOA-ProvideAssistanceData* IE. The position of neighbour Cell 2 in the *OTDOA-NeighbourCellInfoList* is randomly selected to be in the first 7 elements of the sequence, and the position of neighbour Cell 3 is randomly selected to be in the last 8 elements of the sequence, as described in 3GPP TS 37.571-5 [20], clause 7.2.3.
8. The SS shall send a LPP REQUEST LOCATION INFORMATION message, including the *OTDOA-RequestLocationInformation* IE such that the UE receives the message  $\Delta T$  ms before the start of T2, where  $\Delta T = 150$  ms.
9. When T1 expires, the SS shall switch the power setting from T1 to T2 as specified in Table 9.2.1.5-2.
10. When T2 expires, the SS shall switch the power setting from T2 to T3 as specified in Table 9.2.1.5-2.
11. The UE shall transmit a LPP PROVIDE LOCATION INFORMATION message including the *OTDOA-ProvideLocationInformation* IE within the response time (see clause 4.7.3) specified in clause 9.2.1.5. The UE shall perform and report the RSTD measurements for both Cell 2 and Cell 3 with respect to the reference cell in the OTDOA assistance data, Cell 1. If the UE transmits an *OTDOA-ProvideLocationInformation* IE including the *rstd* field for both Cell 2 and Cell 3 within the response time then the number of successful tests is increased by one. If the UE fails to report the *OTDOA-ProvideLocationInformation* IE with both the *rstd* fields included within the response time then the number of failure tests is increased by one.
12. If the UE message at step 11 includes the *ackRequested* IE set to TRUE, the SS shall send a LPP acknowledgement message.
13. Repeat steps 2-12 until the confidence level according to Annex D is achieved. For each iteration, at step 7 change the random position of the Cells 2 and 3 in the *OTDOA-NeighbourCellInfoList*.

#### 9.2.1.4.3 Message contents

**Table 9.2.1.4.3-1: RESET UE POSITIONING STORED INFORMATION**

Derivation Path: 36.509 clause 6.9			
Information Element	Value/remark	Comment	Condition
UE Positioning Technology	0 0 0 0 0 0 1	OTDOA	

**Table 9.2.1.4.3-2: MAC-MainConfig-RBC: FDD-FDD Inter-frequency RSTD Measurement Reporting Delay**

Derivation Path: TS 36.508 [18] clause 4.8.2.1.5, Table 4.8.2.1.5-1 MAC-MainConfig-RBC			
Information Element	Value/remark	Comment	Condition
MAC-MainConfig-RBC ::= SEQUENCE {			
drx-Config CHOICE {			
setup SEQUENCE {			
onDurationTimer	psf1		
drx-InactivityTimer	psf1		
drx-RetransmissionTimer	sf1		
longDRX-CycleStartOffset CHOICE {			
sf320	0		
}			
shortDRX	Not present		
}			
}			



**Table 9.2.1.4.3-3: *MeasGapConfig-GP1*: FDD-FDD inter-frequency RSTD Measurement Reporting Delay**

Derivation Path: TS 36.508 [18] clause 4.6.6, Table 4.6.6-1A: MeasGapConfig-GP1			
Information Element	Value/remark	Comment	Condition
MeasGapConfig-GP1 ::= CHOICE {			
setup SEQUENCE {			
gapOffset CHOICE {			
gp0	9	TGRP = 40 ms	
}			
}			
}			

Table 9.2.1.4.3-4: LPP RequestLocationInformation

Derivation Path: 36.355 clause 6.2			
Information Element	Value/remark	Comment	Condition
LPP-Message ::= SEQUENCE {			
transactionID SEQUENCE {			
initiator	locationServer		
transactionNumber	1		
}			
endTransaction	FALSE		
sequenceNumber	Not present		
acknowledgement	Not present		
lpp-MessageBody CHOICE {			
c1 CHOICE {			
requestLocationInformation SEQUENCE {			
criticalExtensions CHOICE {			
c1 CHOICE {			
requestLocationInformation-r9 SEQUENCE {			
commonIEsRequestLocationInformation SEQUENCE {			
locationInformationType	locationMeasurementsRequired		
triggeredReporting	Not present		
periodicalReporting	Not present		
additionalInformation	onlyReturnInformationRequested		
qos SEQUENCE {			
horizontalAccuracy	Not present		
verticalCoordinateRequest	FALSE		
verticalAccuracy	Not present		
responseTime	6	See clause 9.2.1.5	
velocityRequest	FALSE		
}			
environment	Not present		
locationCoordinateTypes	Not present		
velocityTypes	Not present		
}			
a-gnss-RequestLocationInformation	Not present		
otdoa-RequestLocationInformation SEQUENCE {			
assistanceAvailability	FALSE		
}			
ecid-RequestLocationInformation	Not present		
epdu-RequestLocationInformation	Not Present		
}			
}			
}			
}			

Table 9.2.1.4.3-5: LPP ProvideAssistanceData

Derivation Path: 36.355 clause 6.2			
Information Element	Value/remark	Comment	Condition
LPP-Message ::= SEQUENCE {			
transactionID SEQUENCE {			
Initiator	locationServer		
transactionNumber	(0..255)		
}			
endTransaction	TRUE		
sequenceNumber	Not present		
acknowledgement	Not present		
lpp-MessageBody CHOICE {			
c1 CHOICE {			
provideAssistanceData SEQUENCE {			
criticalExtensions CHOICE {			
c1 CHOICE {			
provideAssistanceData-r9 SEQUENCE {			
commonIEs ProvideAssistanceData	Not present		
a-gnss-ProvideAssistanceData	Not present		
otdoa-ProvideAssistanceData SEQUENCE {			
otdoa-ReferenceCellInfo	As defined in TS 37.571-5 [20], clause 7.2.2.		
otdoa-NeighbourCellInfo	As defined in TS 37.571-5 [20], clause 7.2.2.		
otdoa-Error	Not present		
}			
epdu-ProvideAssistanceData	Not present		
}			
}			
}			
}			

Table 9.2.1.4.3-6: LPP ProvideLocation Information

Derivation Path: 36.355 clause 6.2			
Information Element	Value/remark	Comment	Condition
LPP-Message ::= SEQUENCE {			
transactionID SEQUENCE {			
initiator	locationServer		
transactionNumber	1		
}			
endTransaction	TRUE		
sequenceNumber	(0..255)		
acknowledgement			
lpp-MessageBody CHOICE {			
c1 CHOICE {			
provideLocationInformation SEQUENCE {			
criticalExtensions CHOICE {			
c1 CHOICE {			
provideLocationInformation-r9 SEQUENCE {			
commonEsProvideLocationInformation	Not present.		
a-gnss-ProvideLocationInformation	Not present		
otdoa-ProvideLocationInformation SEQUENCE {			
otdoaSignalMeasurementInformation SEQUENCE {			
systemFrameNumber			
physCellIdRef	Cell 1		
cellGlobalIdRef			
earfcnRef			
referenceQuality			
neighbourMeasurementList SEQUENCE (SIZE(n)) {			
physCellIdNeighbor	Cell 2		
cellGlobalIdNeighbour			
earfcnNeighbour	RF channel 2		
rstd	Present		
rstd-Quality			
}			
neighbourMeasurementList SEQUENCE (SIZE(n)) {			
physCellIdNeighbor	Cell 3		
cellGlobalIdNeighbour			
earfcnNeighbour	RF channel 2		
rstd	Present		
rstd-Quality			
}			
}			
otdoa-Error	Maybe present with error reason 'undefined' or 'attemptedButUnableToMeasureSomeNeighbourCells'		
}			
ecid-ProvideLocationInformation	Not present		
epdu-ProvideLocationInformation	Not present		
}			
}			
}			
}			
}			
}			

9.2.1.5 Test requirement

Table 9.2.1.5-1 and 9.2.1.5-2 define the primary level settings including test tolerances for the test.

**Table 9.2.1.5-1: Cell-specific test parameters for E-UTRAN FDD-FDD inter-frequency RSTD measurement reporting delay under fading propagation conditions during T1**

Parameter	Unit	Cell 1	Cell 2	Cell 3
E-UTRA RF Channel Number		1	N/A	N/A
OCNG patterns defined in TS 36.521-3 [25] clause D.1.1		OP.5 FDD	N/A	N/A
PBCH_RA	dB	0	N/A	N/A
PBCH_RB				
PSS_RA				
SSS_RA				
PCFICH_RB				
PHICH_RA				
PHICH_RB				
PDCCH_RA				
PDCCH_RB				
OCNG_RA <sup>Note 1</sup>				
OCNG_RB <sup>Note 1</sup>				
$N_{oc}$ <sup>Note 3</sup>				
$PRS \hat{E}_s / N_{oc}$	dB	-Infinity	-Infinity	-Infinity
$I_o$ <sup>Note 4</sup>	dBm/ 9 MHz	-66.03	N/A	N/A
$\hat{E}_s / N_{oc}$	dB	-5	-Infinity	-Infinity
Propagation Condition		ETU30		
<p>Note 1: OCNG shall be used such that the active cell (Cell 1) is fully allocated and a constant total transmitted power spectral density is achieved for all OFDM symbols.</p> <p>Note 2: The resources for uplink transmission are assigned to the UE prior to the start of time period T2.</p> <p>Note 3: Interference from other cells and noise sources not specified in the test are assumed to be constant over subcarriers and time and shall be modelled as AWGN of appropriate power for <math>N_{oc}</math> to be fulfilled.</p> <p>Note 4: <math>I_o</math> levels have been derived from other parameters and are given for information purpose. These are not settable test parameters.</p>				

**Table 9.2.1.5-2: Cell-specific test parameters for E-UTRAN FDD-FDD inter-frequency RSTD measurement reporting delay under fading propagation conditions during T2 and T3**

Parameter	Unit	Cell 1		Cell 2		Cell 3	
		T2	T3	T2	T3	T2	T3
E-UTRA RF Channel Number		1		2		2	N/A
OCNG patterns defined in TS 36.521-3 [25] clause D.1.1		OP.5 FDD		OP.6 FDD		OP.6 FDD	N/A
PBCH_RA	dB	0		0		0	N/A
PBCH_RB							
PSS_RA							
SSS_RA							
PCFICH_RB							
PHICH_RA							
PHICH_RB							
PDCCH_RA							
PDCCH_RB							
OCNG_RA <sup>Note 1</sup>							
OCNG_RB <sup>Note 1</sup>							
PRS_RA	dB	-6	N/A	N/A	0	0	N/A
$N_{oc}$ <sup>Note 3,4</sup>	dBm/15 kHz	-98	-98	-98	-95	-98	N/A
$PRS \hat{E}_s / N_{oc}$ <sup>Note 4</sup>	dB	-4+TT	-Infinity	-Infinity	-10+TT	-11+TT	-Infinity
$PRS \hat{E}_s / I_{ot}$ <sup>Note 4</sup>	dB	-4+TT	-Infinity	-Infinity	-10+TT	-11+TT	-Infinity
$I_o$ <sup>Note 4</sup>	dBm/9 MHz	-69.94	-70.22	-70.16	-67.15	-70.16	N/A
PRP <sup>Note 4</sup>	dBm/15 kHz	-102+TT	-Infinity	-Infinity	-105+TT	-109+TT	-Infinity
RSRP <sup>Note 4</sup>	dBm/15 kHz	-96+TT	-96+TT	-105+TT	-105+TT	-109+TT	-Infinity
$\hat{E}_s / N_{oc}$ <sup>Note 4</sup>	dB	2+TT	2+TT	-7+TT	-10+TT	-11+TT	-Infinity
Propagation Condition		ETU30					
<p>Note 1: OCNG shall be used such that active cells (all, except Cell 3 in T3) are fully allocated and a constant total transmitted power spectral density is achieved for all OFDM symbols other than those in the subframes with transmitted PRS. There is no PDSCH allocated in the subframes with transmitted PRS.</p> <p>Note 2: The resources for uplink transmission are assigned to the UE prior to the start of time period T2.</p> <p>Note 3: Interference from other cells and noise sources not specified in the test and assumed to be constant over subcarriers and time and shall be modelled as AWGN of appropriate power for <math>N_{oc}</math> to be fulfilled.</p> <p>Note 4: If PRS_RA is "N/A", <math>\hat{E}_s / N_{oc}</math>, <math>PRS \hat{E}_s / I_{ot}</math>, <math>I_o</math>, RSRP and PRP levels have been derived from other parameters and are given for information purpose. If PRS_RA is "N/A", <math>I_o</math> and RSRP levels have been derived from other parameters and are given for information purpose. These are not settable test parameters. Interference conditions shall be applied to all PRS symbols of DL positioning subframes.</p>							

The response time including test tolerance is [6.3] s. The response time is equal to the LPP responseTime IE value plus the test tolerance. The LPP responseTime IE value is derived from the RSTD reporting delay plus  $\Delta T$ , where  $\Delta T = 150$  ms, giving a value of 5110 ms. This is rounded up to the next allowed LPP value of 6 seconds. The RSTD measurement

reporting delay in the test is derived from the following expression,  $T_{PRS} (M - 1) + 160 \left\lceil \frac{n}{M} \right\rceil$ , where  $M = 16$  and

$n=16$  are the parameters specified in clause 9.2.1.3 and Table 9.2.1.3-1. This gives the total RSTD reporting delay of 4960 ms for the 15 neighbour cells including Cell 2 and Cell 3 with respect to the reference cell, Cell 1.

The test tolerances are defined in clauses C.1.3 and C4.

The rate of successful tests during repeated tests shall be at least 90% with a confidence level of 95%.

## 9.2.2 TDD-TDD inter-frequency RSTD measurement reporting delay

**Editor's note: This test case is incomplete. The following aspects are either missing or not yet determined:**

- *The Test system uncertainties applicable to this test are undefined.*
- *The Test tolerances applicable to this test are undefined.*
- *Other possible applicability is FFS.*

### 9.2.2.1 Test purpose

To verify that the TDD-TDD inter-frequency RSTD measurement reporting delay meets the requirements in an environment with fading propagation conditions.

### 9.2.2.2 Test applicability

This test applies to all types of E-UTRA TDD UE release 10 and forward. Other possible applicability is FFS.

### 9.2.2.3 Minimum conformance requirements

When the physical layer cell identities of neighbour cells together with the OTDOA assistance data are provided, the UE shall be able to detect and measure inter-frequency RSTD, specified in 3GPP TS 36.214 [6], for at least  $n=16$  cells, including the reference cell, within  $T_{\text{RSTD InterFreqTDD, E-UTRAN}}$  ms as given below:

$$T_{\text{RSTD InterFreqTDD, E-UTRAN}} = T_{\text{PRS}} \cdot (M - 1) + \Delta \quad \text{ms},$$

where

$T_{\text{RSTD InterFreqTDD, E-UTRAN}}$  is the total time for detecting and measuring at least  $n$  cells,

$T_{\text{PRS}}$  is the largest value of the cell-specific positioning subframe configuration period, defined in 3GPP TS 36.211 [26], among the measured  $n$  cells including the reference cell,

$M$  is the number of PRS positioning occasions as defined in Table 9.2.2.3-1, where each PRS positioning occasion comprises of  $N_{\text{PRS}}$  ( $1 \leq N_{\text{PRS}} \leq 6$ ) consecutive downlink positioning subframes defined in 3GPP TS 36.211 [26], and

$\Delta = 160 \cdot \left\lceil \frac{n}{M} \right\rceil$  ms is the measurement time for a single PRS positioning occasion which includes the sampling time and the processing time.

**Table 9.2.2.3-1: Number of PRS positioning occasions within  $T_{\text{RSTD InterFreqTDD, E-UTRAN}}$**

Positioning subframe configuration period $T_{\text{PRS}}$	Number of PRS positioning occasions $M$	
	$f2$ <sup>Note 1</sup>	$f1$ and $f2$ <sup>Note 2</sup>
160 ms	16	32
>160 ms	8	16
Note 1: When inter-frequency RSTD measurements are performed over the reference cell and neighbour cells, which belong to the TDD inter-frequency carrier frequency $f2$ . Note 2: When inter-frequency RSTD measurements are performed over the reference cell and the neighbour cells, which belong to the serving TDD carrier frequency $f1$ and the TDD inter-frequency carrier frequency $f2$ respectively.		

The UE physical layer shall be capable of reporting RSTD for the reference cell and all the neighbour cells  $i$  out of at least  $(n-1)$  neighbour cells within  $T_{\text{RSTD InterFreqTDD, E-UTRAN}}$  provided:

$$\left( \text{PRS } \hat{E}_s / \text{Iot} \right)_{\text{ref}} \geq -6 \text{ dB for all Frequency Bands for the reference cell,}$$

$$\left( \text{PRS } \hat{E}_s / \text{Iot} \right)_i \geq -13 \text{ dB for all Frequency Bands for neighbour cell } i,$$

$\left( \text{PRS } \hat{E}_s / \text{Iot} \right)_{\text{ref}}$  and  $\left( \text{PRS } \hat{E}_s / \text{Iot} \right)_i$  conditions apply for all subframes of at least  $L = \frac{M}{2}$  PRS positioning occasions,

PRP 1,2<sub>dBm</sub> according to E.3 for a corresponding Band.

$\text{PRS } \hat{E}_s / \text{Iot}$  is as defined in Section 9.1.1.3.

The time  $T_{\text{RSTD InterFreqTDD, E-UTRAN}}$  starts from the first subframe of the PRS positioning occasion closest in time after both the OTDOA-RequestLocationInformation message and the OTDOA assistance data in the OTDOA-ProvideAssistanceData message as specified in 3GPP TS 36.355 [4], are delivered to the physical layer of the UE.

This requirement assumes that the measurement report is not delayed by other LPP signalling on the DCCH. This measurement reporting delay excludes a delay uncertainty resulted when inserting the measurement report to the TTI of the uplink DCCH. The delay uncertainty is:  $2 \times T_{\text{TI}_{\text{DCCH}}}$ . This measurement reporting delay excludes any delay caused by no UL resources for UE to send the measurement report.

The normative reference for this requirement is TS 36.133 [23] clause 8.1.2.6.1 and A.8.13.1.

## 9.2.2.4 Test description

### 9.2.2.4.1 Initial conditions

Test Environment: Normal; as defined in TS 36.508 [18] clause 4.1.

Frequencies to be tested: Mid Range, as defined in TS 36.508 [18] clause 4.3.1.1.

Channel bandwidth to be tested: 10 MHz as defined in TS 36.508 [18] clause 4.3.1.

1. Connect the SS, faders and AWGN noise sources to the UE antenna connector or antenna connectors as shown in Annex A, Figure A.4.
2. The general test parameter settings are set up according to Table 9.2.2.4.1-1.
3. Propagation conditions are set according to clause 4.7.2.1.
4. Message contents are defined in clause 9.2.2.4.3.
5. In the test there are three synchronized cells: Cell 1, Cell 2 and Cell 3. Cell 1 is the OTDOA assistance data reference as well as the serving cell. Cell 2 and Cell 3 are the neighbour cells. Cell 1 is on TDD RF channel 1. Cell 2 and Cell 3 are on a TDD RF channel 2. The assistance data neighbour cell list includes in total 15 cells, where 13 of the cells are not simulated (dummy cells; as defined in 3GPP TS 37.571-5 clause 7.2.2).
6. The true RSTD (which is the receive time difference for frame 0 between two cells as seen at the UE antenna connector) is set to 0 Ts (0  $\mu$ s) between neighbour Cell 2 and serving Cell 1; and set to 92 Ts (about 3  $\mu$ s) between neighbour Cell 3 and serving Cell 1.
7. The gap pattern configuration # 0 as defined in Table 8.1.2.1-1 in 3GPP TS 36.133 [23] is configured and does not overlap with PRS subframes of Cell 1.



**Table 9.2.2.4.1-1: General test parameters for E-UTRAN TDD-TDD inter-frequency RSTD measurement reporting delay under fading propagation conditions**

Parameter	Unit	Value	Comment
Reference cell		Cell 1	Reference cell is the cell with respect to which the RSTD measurement is defined, as specified in 3GPP TS 36.214 [6] and 3GPP TS 36.355 [4]. The reference cell is the serving cell on RF channel 1 in this test case.
Neighbour cells		Cell 2 and Cell 3	Cells on RF channel 2. The cells appear at random places in the neighbour cell list in the OTDOA assistance data, but Cell 2 always appears in the first half of the list, whilst Cell 3 appears in the second half of the list.
PCFICH/PDCCH/PHICH parameters		DL Reference Measurement Channel R.6 TDD	As specified in TS 36.521-3 [25] clause A.2.1
Channel Bandwidth ( $BW_{\text{channel}}$ )	MHz	10	
PRS Bandwidth <sup>Note 2</sup>	RB	50	PRS are transmitted over the system bandwidth
Gap pattern Id		0	As specified in Table 8.1.2.1-1 in TS 36.133 [23].
Gap offset		12	As specified in 36.331 [22], Section 6.3.5
PRS configuration index $I_{\text{PRS}}$ <sup>Note 2</sup>		Cell 1: 184, Cell 2, Cell 3: 174	This corresponds to periodicity of 320 ms and PRS subframe offset of $I_{\text{PRS}} - 160$ DL subframes, as defined in 3GPP TS 36.211 [26], Table 6.10.4.3-1
Number of consecutive downlink positioning subframes $N_{\text{PRS}}$ <sup>Note 2</sup>		1	As defined in TS 36.211 [26]. The number of subframes in a positioning occasion
Physical cell ID $PCI$ <sup>Note 2</sup>		$(PCI \text{ of Cell 1} - PCI \text{ of Cell 2}) \bmod 6 = 0$ and $(PCI \text{ of Cell 1} - PCI \text{ of Cell 3}) \bmod 6 = 0$	The cell PCIs are selected such that the relative shifts of PRS patterns among cells are as given by the test parameters
TDD uplink-downlink configuration		1	As specified in TS 36.211 [26], Section 4.2; corresponds to a configuration with 5 ms switch-point periodicity and two downlink consecutive subframes
TDD special subframe configuration		6	As specified in TS 36.211 [26], Section 4.2; corresponds to DwPTS of $19760 \cdot T_s$ and UpPTS of $4384 \cdot T_s$
CP length <sup>Note 2</sup>		Normal	
DRX		ON	DRX parameters are further specified in Table 9.2.2.4.1-2
prs-SubframeOffset <sup>Note 2</sup>		310	Number of subframes rounded to the closest integer. The corresponding parameter in the OTDOA assistance data is prs-SubframeOffset specified in TS 36.355 [4]
slotNumberOffset <sup>Note 2</sup>		0	The slot number offset at the transmitter between a neighbour cell and the assistance data reference cell specified in TS 36.355 [4]
Maximum subframe shift between the cells at the UE antenna connector <sup>Note 3</sup>	$\mu\text{s}$	3	Synchronous cells

Expected RSTD <sup>Note 1</sup>	μs	3	The expected RSTD is what is expected at the receiver. The corresponding parameter in the OTDOA assistance data specified in TS 36.355 [4] is the expectedRSTD indicator
Expected RSTD uncertainty <sup>Note 1</sup>	μs	5	The corresponding parameter in the OTDOA assistance data specified in TS 36.355 [4] is the expectedRSTD-Uncertainty index
Number of cells provided in OTDOA assistance data		16	The list includes the reference cell (received in <i>OTDOA-ReferenceCellInfo</i> [4]) on RF channel 1 and 15 other cells on RF channel 2, all received in <i>OTDOA-ProvideAssistanceData</i> [4].
PRS muting info <sup>Note 2</sup>		Cell 1: '1111111100000000' Cell 2: '0000000011111111' Cell 3: '1111111100000000'	Corresponds to prs-MutingInfo defined in TS 36.355 [4]
T1	s	3	The length of the time interval from the beginning of each test
T2	s	2.48	The length of the time interval that follows immediately after time interval T1
T3	s	2.48	The length of the time interval that follows immediately after time interval T2
Note 1:	Parameters "Expected RSTD" and "Expected RSTD uncertainty" are not settable parameters. These are parameters signalled in LPP only. For the values to be used in LPP see Table 9.2.2.4.3-5 and TS 37.571-5 [20], clause 7.2.2.		
Note 2:	Parameters "PRS Bandwidth", "PRS configuration index", "Number of consecutive downlink positioning subframes", "Physical cell ID PCI", "CP length", "prs-SubframeOffset", "slotNumberOffset" and "PRS muting info" are settable parameters and also parameters signalled in LPP. The values to be used for "Physical cell ID PCI" are as follows: Cell 1: 0, Cell 2: 6, Cell 3: 12. For all the values to be used in LPP see Table 9.2.2.4.3-5 and TS 37.571-5 [20], clause 7.2.2.		
Note 3:	The parameter "Maximum subframe shift between the cells at the UE antenna connector" is not a settable parameter but is used to set the "true RSTD" values in step 6 of clause 9.2.2.4.1.		

**Table 9.2.2.4.1-2: DRX parameters for E-UTRAN TDD-TDD inter-frequency RSTD measurement reporting delay under fading propagation conditions**

Field	Value	Comment
onDurationTimer	psf1	As specified in 3GPP TS 36.331 [22], clause 6.3.2
drx-InactivityTimer	psf1	
drx-RetransmissionTimer	sf1	
longDRX-CycleStartOffset	sf320	
shortDRX	Disable	

#### 9.2.2.4.2 Test procedure

The test consists of three consecutive time intervals, with duration of T1, T2 and T3 defined in Table 9.2.2.4.1-1. Cell 1 is active in T1, T2 and T3, whilst Cell 2 and Cell 3 are activated only in the beginning of T2. Cell 2 is active until the end of T3, and Cell 3 is active until the end of T2. The beginning of the time interval T2 shall be aligned [5] ms before the first PRS positioning subframe of a positioning occasion in the reference cell, where [5] ms is the necessary test tolerance. Cell 1 transmits PRS only in T2, Cell 2 transmits PRS only in T3, and Cell 3 transmits PRS only in T2.

**NOTE:** The information on when PRS is muted is conveyed to the UE using PRS muting information in the OTDOA assistance data.

The OTDOA-RequestLocationInformation message and the OTDOA assistance data as defined in clause 9.2.2.4.3 shall be provided to the UE during T1. The last TTI containing the OTDOA-RequestLocationInformation message shall be provided to the UE  $\Delta T$  ms before the start of T2, where  $\Delta T = 150$  ms is the maximum processing time of the OTDOA-RequestLocationInformation message and the OTDOA assistance data.

1. Ensure that the UE is in state Generic RB Established State 3A-RF according to 3GPP TS 36.508 [18] clause 7.2A.3.
2. The SS shall send a RESET UE POSITIONING STORED INFORMATION message.
3. Set the parameters according to Table 9.2.2.5-1. Propagation conditions are set according to clause 4.7.2.2 (ETU30).
4. T1 starts.
5. The SS shall transmit an RRCConnectionReconfiguration message with the DRX configuration and the measurement gap configuration.
6. The UE shall transmit RRCConnectionReconfigurationComplete message.
7. The SS shall send a LPP PROVIDE ASSISTANCE DATA message, including the *OTDOA-ProvideAssistanceData* IE. The position of neighbour Cell 2 in the *OTDOA-NeighbourCellInfoList* is randomly selected to be in the first 7 elements of the sequence, and the position of neighbour Cell 3 is randomly selected to be in the last 8 elements of the sequence, as described in 3GPP TS 37.571-5 [20], clause 7.2.3.
8. The SS shall send a LPP REQUEST LOCATION INFORMATION message, including the *OTDOA-RequestLocationInformation* IE such that the UE receives the message  $\Delta T$  ms before the start of T2, where  $\Delta T = 150$  ms.
9. When T1 expires, the SS shall switch the power setting from T1 to T2 as specified in Table 9.2.2.5-2.
10. When T2 expires, the SS shall switch the power setting from T2 to T3 as specified in Table 9.2.2.5-2.
11. The UE shall transmit a LPP PROVIDE LOCATION INFORMATION message including the *OTDOA-ProvideLocationInformation* IE within the response time (see clause 4.7.3) specified in clause 9.2.2.5. The UE shall perform and report the RSTD measurements for both Cell 2 and Cell 3 with respect to the reference cell in the OTDOA assistance data, Cell 1. If the UE transmits an *OTDOA-ProvideLocationInformation* IE including the *rstd* field for both Cell 2 and Cell 3 within the response time then the number of successful tests is increased by one. If the UE fails to report the *OTDOA-ProvideLocationInformation* IE with both the *rstd* fields included within the response time then the number of failure tests is increased by one.
12. If the UE message at step 11 includes the *ackRequested* IE set to TRUE, the SS shall send a LPP acknowledgement message.
13. Repeat steps 2-12 until the confidence level according to Annex D is achieved. For each iteration, at step 7 change the random position of the Cells 2 and 3 in the *OTDOA-NeighbourCellInfoList*.

9.2.2.4.3 Message contents

**Table 9.2.2.4.3-1: RESET UE POSITIONING STORED INFORMATION**

Derivation Path: 36.509 clause 6.9			
Information Element	Value/remark	Comment	Condition
UE Positioning Technology	0 0 0 0 0 0 1	OTDOA	

**Table 9.2.2.4.3-2: MAC-MainConfig-RBC: TDD-TDD Inter-frequency RSTD Measurement Reporting Delay**

Derivation Path: TS 36.508 [18] clause 4.8.2.1.5, Table 4.8.2.1.5-1 MAC-MainConfig-RBC			
Information Element	Value/remark	Comment	Condition
MAC-MainConfig-RBC ::= SEQUENCE {			
drx-Config CHOICE {			
setup SEQUENCE {			
onDurationTimer	psf1		
drx-InactivityTimer	psf1		
drx-RetransmissionTimer	sf1		
longDRX-CycleStartOffset CHOICE {			
sf320	0		
}			
shortDRX	Not present		
}			
}			
}			

**Table 9.2.2.4.3-3: MeasGapConfig-GP1: TDD-TDD inter-frequency RSTD Measurement Reporting Delay**

Derivation Path: TS 36.508 [18] clause 4.6.6, Table 4.6.6-1A: MeasGapConfig-GP1			
Information Element	Value/remark	Comment	Condition
MeasGapConfig-GP1 ::= CHOICE {			
setup SEQUENCE {			
gapOffset CHOICE {			
gp0	12	TGRP = 40 ms	
}			
}			
}			

Table 9.2.2.4.3-4: LPP RequestLocationInformation

Derivation Path: 36.355 clause 6.2			
Information Element	Value/remark	Comment	Condition
LPP-Message ::= SEQUENCE {			
transactionID SEQUENCE {			
initiator	locationServer		
transactionNumber	1		
}			
endTransaction	FALSE		
sequenceNumber	Not present		
acknowledgement	Not present		
lpp-MessageBody CHOICE {			
c1 CHOICE {			
requestLocationInformation SEQUENCE {			
criticalExtensions CHOICE {			
c1 CHOICE {			
requestLocationInformation-r9 SEQUENCE {			
commonIEsRequestLocationInformation SEQUENCE {			
locationInformationType	locationMeasurementsRequired		
triggeredReporting	Not present		
periodicalReporting	Not present		
additionalInformation	onlyReturnInformationRequested		
qos SEQUENCE {			
horizontalAccuracy	Not present		
verticalCoordinateRequest	FALSE		
verticalAccuracy	Not present		
responseTime	6	See clause 9.2.2.5	
velocityRequest	FALSE		
}			
environment	Not present		
locationCoordinateTypes	Not present		
velocityTypes	Not present		
}			
a-gnss-RequestLocationInformation	Not present		
otdoa-RequestLocationInformation SEQUENCE {			
assistanceAvailability	FALSE		
}			
ecid-RequestLocationInformation	Not present		
epdu-RequestLocationInformation	Not Present		
}			
}			
}			
}			

Table 9.2.2.4.3-5: LPP ProvideAssistanceData

Derivation Path: 36.355 clause 6.2			
Information Element	Value/remark	Comment	Condition
LPP-Message ::= SEQUENCE {			
transactionID SEQUENCE {			
Initiator	locationServer		
transactionNumber	(0..255)		
}			
endTransaction	TRUE		
sequenceNumber	Not present		
acknowledgement	Not present		
lpp-MessageBody CHOICE {			
c1 CHOICE {			
provideAssistanceData SEQUENCE {			
criticalExtensions CHOICE {			
c1 CHOICE {			
provideAssistanceData-r9 SEQUENCE {			
commonIEs ProvideAssistanceData	Not present		
a-gnss-ProvideAssistanceData	Not present		
otdoa-ProvideAssistanceData SEQUENCE {			
otdoa-ReferenceCellInfo	As defined in TS 37.571-5 [20], clause 7.2.2.		
otdoa-NeighbourCellInfo	As defined in TS 37.571-5 [20], clause 7.2.2.		
otdoa-Error	Not present		
}			
epdu-ProvideAssistanceData	Not present		
}			
}			
}			
}			

Table 9.2.2.4.3-6: LPP ProvideLocation Information

Derivation Path: 36.355 clause 6.2			
Information Element	Value/remark	Comment	Condition
LPP-Message ::= SEQUENCE {			
transactionID SEQUENCE {			
initiator	locationServer		
transactionNumber	1		
}			
endTransaction	TRUE		
sequenceNumber	(0..255)		
acknowledgement			
lpp-MessageBody CHOICE {			
c1 CHOICE {			
provideLocationInformation SEQUENCE {			
criticalExtensions CHOICE {			
c1 CHOICE {			
provideLocationInformation-r9 SEQUENCE {			
commonEsProvideLocationInformation	Not present.		
a-gnss-ProvideLocationInformation	Not present		
otdoa-ProvideLocationInformation SEQUENCE {			
otdoaSignalMeasurementInformation SEQUENCE {			
systemFrameNumber			
physCellIdRef	Cell 1		
cellGlobalIdRef			
earfcnRef			
referenceQuality			
neighbourMeasurementList SEQUENCE (SIZE(n)) {			
physCellIdNeighbor	Cell 2		
cellGlobalIdNeighbour			
earfcnNeighbour	RF channel 2		
rstd	Present		
rstd-Quality			
}			
neighbourMeasurementList SEQUENCE (SIZE(n)) {			
physCellIdNeighbor	Cell 3		
cellGlobalIdNeighbour			
earfcnNeighbour	RF channel 2		
rstd	Present		
rstd-Quality			
}			
}			
otdoa-Error	Maybe present with error reason 'undefined' or 'attemptedButUnableToMeasureSomeNeighbourCells'		
}			
ecid-ProvideLocationInformation	Not present		
epdu-ProvideLocationInformation	Not present		
}			
}			
}			
}			
}			
}			

### 9.2.2.5 Test requirement

Table 9.2.2.5-1 and 9.2.2.5-2 define the primary level settings including test tolerances for the test.

**Table 9.2.2.5-1: Cell-specific test parameters for E-UTRAN TDD-TDD inter-frequency RSTD measurement reporting delay under fading propagation conditions during T1**

Parameter	Unit	Cell 1	Cell 2	Cell 3
E-UTRA RF Channel Number		1	N/A	N/A
OCNG patterns defined in TS 36.521-3 [25] clause D.1.1		OP.1 TDD	N/A	N/A
PBCH_RA	dB	0	N/A	N/A
PBCH_RB				
PSS_RA				
SSS_RA				
PCFICH_RB				
PHICH_RA				
PHICH_RB				
PDCCH_RA				
PDCCH_RB				
OCNG_RA <sup>Note 1</sup>				
OCNG_RB <sup>Note 1</sup>				
$N_{oc}$ <sup>Note 3</sup>	dBm/15 kHz	-95	N/A	N/A
$PRS \hat{E}_s / N_{oc}$	dB	-Infinity	-Infinity	-Infinity
$I_o$ <sup>Note 4</sup>	dBm/9 MHz	-66.03	N/A	N/A
$\hat{E}_s / N_{oc}$	dB	-5	-Infinity	-Infinity
Propagation Condition		ETU30		
<p>Note 1: OCNG shall be used such that the active cell (Cell 1) is fully allocated and a constant total transmitted power spectral density is achieved for all OFDM symbols.</p> <p>Note 2: The resources for uplink transmission are assigned to the UE prior to the start of time period T2.</p> <p>Note 3: Interference from other cells and noise sources not specified in the test are assumed to be constant over subcarriers and time and shall be modelled as AWGN of appropriate power for <math>N_{oc}</math> to be fulfilled.</p> <p>Note 4: <math>I_o</math> levels have been derived from other parameters and are given for information purpose. These are not settable test parameters.</p>				



**Table 9.2.2.5-2: Cell-specific test parameters for E-UTRAN TDD-TDD inter-frequency RSTD measurement reporting delay under fading propagation conditions during T2 and T3**

Parameter	Unit	Cell 1		Cell 2		Cell 3	
		T2	T3	T2	T3	T2	T3
E-UTRA RF Channel Number		1		2		2	N/A
OCNG patterns defined in TS 36.521-3 [25] clause D.1.1		OP.1 TDD		OP.2 TDD		OP.2 TDD	N/A
PBCH_RA	dB	0		0		0	N/A
PBCH_RB							
PSS_RA							
SSS_RA							
PCFICH_RB							
PHICH_RA							
PHICH_RB							
PDCCH_RA							
PDCCH_RB							
OCNG_RA <sup>Note 1</sup>							
OCNG_RB <sup>Note 1</sup>							
PRS_RA	dB	-6	N/A	N/A	0	0	N/A
$N_{oc}$ <sup>Note 3</sup>	dBm/15 kHz	-98	-98	-98	-95	-98	N/A
$\widehat{E}_s/N_{oc}$	dB	-4+TT	-Infinity	-Infinity	-10+TT	-11+TT	-Infinity
$\widehat{E}_s/I_{ot}$ <sup>Note 4</sup>	dB	-4+TT	-Infinity	-Infinity	-10+TT	-11+TT	-Infinity
$I_o$ <sup>Note 4</sup>	dBm/9 MHz	-69.94	-70.22	-70.16	-67.15	-70.16	N/A
PRP <sup>Note 4</sup>	dBm/15 kHz	-102+TT	-Infinity	-Infinity	-105+TT	-109+TT	-Infinity
RSRP <sup>Note 4</sup>	dBm/15 kHz	-96+TT	-96+TT	-105+TT	-105+TT	-109+TT	-Infinity
$\widehat{E}_s/N_{oc}$ <sup>Note 4</sup>	dB	2	2	-7	-10	-11	-Infinity
Propagation Condition		ETU30					
<p>Note 1: OCNG shall be used such that active cells (all, except Cell 3 in T3) are fully allocated and a constant total transmitted power spectral density is achieved for all OFDM symbols other than those in the subframes with transmitted PRS. There is no PDSCH allocated in the subframes with transmitted PRS.</p> <p>Note 2: The resources for uplink transmission are assigned to the UE prior to the start of time period T2.</p> <p>Note 3: Interference from other cells and noise sources not specified in the test are assumed to be constant over subcarriers and time and shall be modelled as AWGN of appropriate power for <math>N_{oc}</math> to be fulfilled.</p> <p>Note 4: If PRS_RA is "N/A", <math>\widehat{E}_s/N_{oc}</math>, <math>\widehat{E}_s/I_{ot}</math>, <math>I_o</math>, RSRP and PRP levels have been derived from other parameters and are given for information purpose. If PRS_RA is "N/A", <math>I_o</math> and RSRP levels have been derived from other parameters and are given for information purpose. These are not settable test parameters. Interference conditions shall be applied to all PRS symbols of DL positioning subframes</p>							

The response time including test tolerance is [6.3] s. The response time is equal to the LPP responseTime IE value plus the test tolerance. The LPP responseTime IE value is derived from the RSTD reporting delay plus  $\Delta T$ , where  $\Delta T = 150$  ms, giving a value of 5110 ms. This is rounded up to the next allowed LPP value of 6 seconds. The RSTD measurement reporting delay in the test is derived from the following expression,  $T_{PRS}(M-1) + 160 \left\lceil \frac{n}{M} \right\rceil$ , where  $M = 16$  and

$n=16$  are the parameters specified in clause 9.2.2.3 and Table 9.2.2.3-1. This gives the total RSTD reporting delay of 4960 ms for the 15 neighbour cells including Cell 2 and Cell 3 with respect to the reference cell, Cell 1.

The test tolerances are defined in clauses C.1.3 and C4.

The rate of successful tests during repeated tests shall be at least 90% with a confidence level of 95%.

### 9.2.3 Void

### 9.2.4 FDD-FDD inter frequency RSTD Accuracy

**Editor's note:** This section is incomplete. The following aspects are either missing or not yet determined:

- *The Test system uncertainties applicable to this test are undefined*
- *The Test tolerances applicable to this test are undefined Whether inter-frequency RSTD measurement is a mandatory or optional feature*

#### 9.2.4.1 Test purpose

To verify that the Reference Signal Time Difference (RSTD) FDD-FDD inter-frequency measurement accuracy is within the specified limit for all bands in AWGN channels.

#### 9.2.4.2 Test applicability

This test applies to all types of E-UTRA FDD UE release 10 and forward. Other possible applicability is FFS.

#### 9.2.4.3 Minimum conformance requirements

The accuracy of FDD-FDD inter-frequency RSTD measurement shall meet the requirement defined in the Table 9.2.4.3-1 without DRX as well as for all the DRX cycles specified in TS 36.331 [22].

The accuracy requirements in Table 9.2.4.3-1 are valid under the following conditions:

Conditions defined in TS 36.101 [2] Section 7.3 for reference sensitivity are fulfilled.

PRP  $1,2_{\text{dBm}}$  according to clause E.3 for a corresponding Band.

There are no measurement gaps overlapping with the PRS subframes in cells belonging to the serving carrier frequency.

The parameter  $\text{expectedRSTDUncertainty}$  signalled over LPP by E-SMLC as defined in TS 36.355 [4] is less than 5  $\mu\text{s}$ .

Table 9.2.4.3-1: RSTD measurement accuracy

Accuracy	Conditions					
	PRS $\hat{E}_s/\text{lot}$	Minimum PRS bandwidth between the reference cell and the measured neighbour cell $i$	Minimum number of available measurement subframes among the reference cell and the measured neighbour cell $i$	Io <sup>Note 7</sup> range		
				E-UTRA operating bands	Minimum Io <sup>Note 1</sup>	Maximum Io
Ts <sup>Note 2</sup>	dB	RB		dBm/15kHz	dBm/BW <sub>Channel</sub>	
±21	(PRS $\hat{E}_s/\text{lot}$ ) <sub>ref</sub> ≥ -6dB and (PRS $\hat{E}_s/\text{lot}$ ) <sub>i</sub> ≥ -13dB	≥ 6	4	1, 4, 6, 10, 11, 18, 19, 21, 23, 24, 33, 34, 35, 36, 37, 38, 39, 40	-121	-50
				9, 42, 43	-120	-50
				28	-119.5	-50
				2, 5, 7, 27, 41, [44]	-119	-50
				26	-118.5 <sup>Note 4</sup>	-50
				3, 8, 12, 13, 14, 17, 20, 22, 29 <sup>Note 6</sup>	-118	-50
			25	-117.5	-50	
±10	(PRS $\hat{E}_s/\text{lot}$ ) <sub>ref</sub> ≥ -6dB and (PRS $\hat{E}_s/\text{lot}$ ) <sub>i</sub> ≥ -13dB	≥ 25	≥ 2	Note 5	Note 5	Note 5
±9	(PRS $\hat{E}_s/\text{lot}$ ) <sub>ref</sub> ≥ -6dB and (PRS $\hat{E}_s/\text{lot}$ ) <sub>i</sub> ≥ -13dB	≥ 50	≥ 1	Note 5	Note 5	Note 5

NOTE 1: This minimum Io condition is expressed as the average Io per RE over all REs in an OFDM symbol.  
NOTE 2: Ts is the basic timing unit defined in TS 36.211 [16].  
NOTE 3: PRS bandwidth is as indicated in *prs-Bandwidth* in the OTDOA assistance data defined in [24].  
NOTE 4: The condition has the minimum Io of -119 dBm/15kHz when the carrier frequency of the assigned E-UTRA channel bandwidth is within 865-894 MHz.  
NOTE 5: The same bands and the same Io conditions for each band apply for this requirement as for the corresponding requirement with the PRS bandwidth ≥ 6 RB.  
NOTE 6: Band 29 is used only for E-UTRA carrier aggregation with other E-UTRA bands.  
NOTE 7: The Io is defined in PRS positioning subframes. The same Io range applies to PRS and non-PRS symbols. Io levels are different in PRS and non-PRS symbols within the same subframe.

The normative reference for this requirement is TS 36.133 [23] clause 9.1.10.2 and A.9.8.3.

## 9.2.4.4 Test description

### 9.2.4.4.1 Initial conditions

Test Environment: Normal; as defined in TS 36.508 [18] clause 4.1.

Frequencies to be tested: Mid Range, as defined in TS 36.508 [18] clause 4.3.1.1.

Channel bandwidth to be tested: 1.4 MHz (Test 1) and 10 MHz (Test 2). In the case that 1.4MHz channel bandwidth is not defined for the operating band under test, as defined in TS 36.101 [2] clause 5.6.1, then this part of the test shall be omitted.

1. Connect the SS and AWGN noise sources to the UE antenna connector or antenna connectors as shown in Annex A, Figure A.3.
2. The general test parameter settings are set up according to Table 9.2.4.4.1-1.
3. Propagation conditions are set according to clause 4.7.2.1.
4. Message contents are defined in clause 9.2.4.4.3.

5. Two cells are on the different carrier frequencies. Cell 1 is the serving cell and OTDOA assistance data reference cell; Cell 2 is the neighbour cell. The assistance data neighbour cell list includes in total 15 cells, where 14 of the cells are not simulated (dummy cells; as defined in 3GPP TS 37.571-5 [20], clause 7.2.2).
6. The true RSTD (which is the receive time difference for frame 0 between the two cells as seen at the UE antenna connector) is set to 92 Ts (2.99  $\mu$ s) between neighbour cell 2 and serving cell 1.

Note that the related expected RSTD values to be signalled over LPP are defined in Table 9.2.4.4-1.

7. The gap pattern configuration # 0 as defined in Table 8.1.2.1-1 in 3GPP TS 36.133 [23] is configured and does not overlap with PRS subframes of Cell 1.

Table 9.2.4.4.1-1: General Test Parameters for inter-frequency RSTD Tests for E-UTRAN FDD

Parameter	Unit	Value		Comment
		Test1	Test2	
PCFICH/PDCCH/PHICH parameters		R.8 FDD	R.6 FDD	As specified in TS 36.521-3 [25] clause A.2.1
OCNG Patterns defined in TS 36.521-3 [25] clause D.1.1		OP.7 FDD	OP.6 FDD	OCNG shall be used such that both cells are fully allocated and a constant total transmitted power spectral density is achieved for all OFDM symbols (other than those in the PRS subframes). There is no PDSCH allocated in the subframe transmitting PRS.
Reference cell		Cell 1		Cell 1 on RF channel number 1
Neighbour cell		Cell 2		Cell 2 on RF channel number 2
E-UTRA RF Channel Number		1,2		Two FDD carrier frequencies are used.
Channel Bandwidth ( $BW_{channel}$ )	MHz	1.4	10	
GapOffset		14	11	For Cell 1
Gap Pattern ID		0	0	For Cell 1
PRS Bandwidth	RB	6	50	
PRS configuration Index $I_{PRS}$ Note 2		Cell 1: 2 Cell 2: 15	Cell 1: 2 Cell 2: 12	As defined in 3GPP TS 36.211 [26]
PRS subframe offset		13	10	For Cell 2
Number of consecutive positioning downlink subframes $N_{PRS}$ Note 2		6	1	As defined in 3GPP TS 36.211 [26]
prs-MutingInfo Note 2		Cell1:'11110000' Cell2:'11110000'		See section 6.5.1.2 in 3GPP TS 36.355 [4] for more information
Cell ID Note 2		Cell 1: 0 Cell 2: 1		
expectedRSTD Note 1	$\mu$ s	3	3	
expectedRSTDUncertainty Note 1	$\mu$ s	5		
CP length Note 2		Normal		
DRX		OFF		
Radio frame transmit time difference between cells (cell 2 TX time – cell 1 TX time) Note 3	$\mu$ s	3		Synchronous cells
Number of cells provided in OTDOA assistance data		16		The list includes the reference cell (received in <i>OTDOA-ReferenceCellInfo</i> [4]) on RF channel 1 and 15 other cells on RF channel 2, all received in <i>OTDOA-ProvideAssistanceData</i> [4].
$T_{RSTD\ InterFreqFDD, E-UTRAN}$ Note 4	ms	5120		Derived according to the RSTD measurement requirements specified in Section 8.1.2.6.1 in TS 36.133 [23].
<p>NOTE 1: Parameters "Expected RSTD" and "Expected RSTD uncertainty" in Table 9.2.4.4.1-1 are not settable parameters. These are parameters signalled in LPP only. For the values to be used in LPP see Table 9.2.4.4.3-4 and TS 37.571-5 [20], clause 7.2.2.</p> <p>NOTE 2: Parameters "PRS Bandwidth", "PRS configuration index", "Number of consecutive positioning downlink subframes", "prs-MutingInfo", "Cell ID" and "CP length" in Table 9.2.4.4.1-1 are settable parameters and also parameters signalled in LPP. For all the values to be used in LPP see Table 9.2.4.4.3-4 and TS 37.571-5 [20], clause 7.2.2.</p> <p>NOTE 3: The parameter "Radio frame transmit time difference between cells (cell 2 TX time – cell 1 TX time)" is not a settable parameter but is used to set the "true RSTD" values in step 6 of clause 9.2.4.4.1.</p> <p>NOTE 4: The parameter "<math>T_{RSTD\ InterFreqFDD, E-UTRAN}</math>" is not a settable parameter but is used to set the LPP "responseTime" value in Table 9.2.4.4.3-3. The value of the LPP responseTime IE is set to <math>T_{RSTD\ InterFreqFDD, E-UTRAN} + \Delta T</math> ms, where <math>\Delta T = 150</math> ms, giving a value of 5270 ms. This is rounded up to the next allowed LPP value of 6 seconds.</p>				

#### 9.2.4.4.2 Test procedure

The test consists of a set-up period and a measurement period. Cell 1 and Cell 2 are both active during the complete test. The beginning of the measurement period shall be aligned with the first PRS positioning subframe of a positioning occasion in the reference cell.

NOTE: The information on when PRS is muted is conveyed to the UE using PRS muting information in the OTDOA assistance data.

The OTDOA-RequestLocationInformation message and the OTDOA assistance data as defined in clause 9.2.4.4.3 shall be provided to the UE during the set-up period. The last TTI containing the OTDOA-RequestLocationInformation message shall be provided to the UE  $\Delta T$  ms before the start of the measurement period, where  $\Delta T = 150$  ms is the maximum processing time of the OTDOA-RequestLocationInformation message and the OTDOA assistance data in the UE.

1. Ensure that the UE is in state Generic RB Established State 3A-RF according to 3GPP TS 36.508 [18] clause 7.2A.3.
2. The SS shall send a RESET UE POSITIONING STORED INFORMATION message.
3. Set the parameters according to Table 9.2.4.5-1 as appropriate. Propagation conditions are set according to clause 4.7.2.1.
4. The SS shall transmit an RRCConnectionReconfiguration message with the measurement gap configuration.
5. The UE shall transmit RRCConnectionReconfigurationComplete message.
6. The SS shall send a LPP PROVIDE ASSISTANCE DATA message, including the *OTDOA-ProvideAssistanceData* IE.
7. The SS shall send a LPP REQUEST LOCATION INFORMATION message, including the *OTDOA-RequestLocationInformation* IE such that the UE receives the message  $\Delta T$  ms before the start of measurement period, where  $\Delta T = 150$  ms.
8. The UE shall transmit a LPP PROVIDE LOCATION INFORMATION message, including the *OTDOA-ProvideLocationInformation* IE.
9. If the UE message at step 8 includes the *ackRequested* IE set to TRUE, the SS shall send a LPP acknowledgement message.
10. The SS shall check the *rstd* value for Cell 2 in the *OTDOA-SignalMeasurementInformation* IE according to Table 9.2.4.5-2.
11. Repeat step 2-10 until the confidence level according to Annex D is achieved.
12. Repeat step 1-11 for each sub-test in Table 9.2.4.5-1 as appropriate.

#### 9.2.4.4.3 Message contents

**Table 9.2.4.4.3-1: RESET UE POSITIONING STORED INFORMATION**

Derivation Path: 36.509 clause 6.9			
Information Element	Value/remark	Comment	Condition
UE Positioning Technology	0 0 0 0 0 0 1	OTDOA	

**Table 9.2.4.4.3-2: MeasGapConfig-GP1: FDD-FDD inter-frequency RSTD Accuracy**

Derivation Path: TS 36.508 [18] clause 4.6.6, Table 4.6.6-1A: MeasGapConfig-GP1			
Information Element	Value/remark	Comment	Condition
MeasGapConfig-GP1 ::= CHOICE {			
setup SEQUENCE {			
gapOffset CHOICE {			
gp0	14 (Test 1) 11 (Test 2)	TGRP = 40 ms	
}			
}			
}			

**Table 9.2.4.4.3-3: LPP RequestLocationInformation**

Derivation Path: 36.355 clause 6.2			
Information Element	Value/remark	Comment	Condition
LPP-Message ::= SEQUENCE {			
transactionID SEQUENCE {			
initiator	locationServer		
transactionNumber	1		
}			
endTransaction	FALSE		
sequenceNumber	Not present		
acknowledgement	Not present		
lpp-MessageBody CHOICE {			
c1 CHOICE {			
requestLocationInformation SEQUENCE {			
criticalExtensions CHOICE {			
c1 CHOICE {			
requestLocationInformation-r9 SEQUENCE {			
commonIEsRequestLocationInformation SEQUENCE {			
locationInformationType	locationMeasurementsRequired		
triggeredReporting	Not present		
periodicalReporting	Not present		
additionalInformation	onlyReturnInformationRequested		
qos SEQUENCE {			
horizontalAccuracy	Not present		
verticalCoordinateRequest	FALSE		
verticalAccuracy	Not present		
responseTime	6	See Note 4 of Table 9.2.4.4.1-1	
velocityRequest	FALSE		
}			
environment	Not present		
locationCoordinateTypes	Not present		
velocityTypes	Not present		
}			
}			
}			
}			
}			
}			
}			
}			

Table 9.2.4.4.3-4: LPP ProvideAssistanceData

Derivation Path: 36.355 clause 6.2			
Information Element	Value/remark	Comment	Condition
LPP-Message ::= SEQUENCE {			
transactionID SEQUENCE {			
Initiator	locationServer		
transactionNumber	(0..255)		
}			
endTransaction	TRUE		
sequenceNumber	Not present		
acknowledgement	Not present		
lpp-MessageBody CHOICE {			
c1 CHOICE {			
provideAssistanceData SEQUENCE {			
criticalExtensions CHOICE {			
c1 CHOICE {			
provideAssistanceData-r9 SEQUENCE {			
commonIEs ProvideAssistanceData	Not present		
a-gnss-ProvideAssistanceData	Not present		
otdoa-ProvideAssistanceData SEQUENCE {			
otdoa-ReferenceCellInfo	As defined in TS 37.571-5 [20], clause 7.2.2.		
otdoa-NeighbourCellInfo	As defined in TS 37.571-5 [20], clause 7.2.2.		
otdoa-Error	Not present		
}			
epdu-ProvideAssistanceData	Not present		
}			
}			
}			
}			



Table 9.2.4.4.3-5: LPP ProvideLocation Information

Derivation Path: 36.355 clause 6.2			
Information Element	Value/remark	Comment	Condition
LPP-Message ::= SEQUENCE {			
transactionID SEQUENCE {			
initiator	locationServer		
transactionNumber	1		
}			
endTransaction	TRUE		
sequenceNumber	(0..255)		
acknowledgement			
lpp-MessageBody CHOICE {			
c1 CHOICE {			
provideLocationInformation SEQUENCE {			
criticalExtensions CHOICE {			
c1 CHOICE {			
provideLocationInformation-r9 SEQUENCE {			
commonEsProvideLocationInformation	Not present.		
a-gnss-ProvideLocationInformation	Not present		
otdoa-ProvideLocationInformation			
SEQUENCE {			
otdoaSignalMeasurementInformation			
SEQUENCE {			
systemFrameNumber			
physCellIdRef	Cell 1		
cellGlobalIdRef			
earfcnRef			
referenceQuality			
neighbourMeasurementList			
SEQUENCE (SIZE(1)) {			
physCellIdNeighbor	Cell 2		
cellGlobalIdNeighbour			
earfcnNeighbour	RF channel 2		
Rstd	Set according to Table 9.2.4.5-2 for each specific test		
rstd-Quality			
}			
}			
}			
otdoa-Error	Maybe present with error reason 'undefined' or 'attemptedButUnableToMeasureSomeNeighbourCells'		
}			
ecid-ProvideLocationInformation	Not present		
epdu-ProvideLocationInformation	Not present		
}			
}			
}			
}			

### 9.2.4.5 Test requirement

Table 9.2.4.5-1 defines the primary level settings including test tolerances for all tests.

RSTD FDD-FDD inter-frequency accuracy test shall meet the reported values in Table 9.2.4.5-2.

Table 9.2.4.5-1: Cell Specific Test Parameters for inter frequency RSTD Tests for E-UTRAN FDD

Parameter	Unit	Test1		Test2	
		Cell1	Cell2	Cell1	Cell2
E-UTRA RF Channel Number		1	2	1	2
PBCH_RA	dB	0	0	0	0
PBCH_RB					
PSS_RA					
SSS_RA					
PCFICH_RB					
PHICH_RA					
PHICH_RB					
PDCCH_RA					
PDCCH_RB					
OCNG_RA <sup>Note 1</sup>					
OCNG_RB <sup>Note 1</sup>					
PRS_RA					
$N_{oc}$ <sup>Note 2</sup>	dBm/15 kHz	-98			
PRS $\hat{E}_s/N_{oc}$	dB	-6+TT	-13+TT	-6+TT	-13+TT
PRS $\hat{E}_s/I_{ot}$ <sup>Note 3</sup>	dB	-6+TT	-13+TT	-6+TT	-13+TT
$I_o$ <sup>Note 3</sup>	dBm/1.08 MHz	-79.25	-79.39	N/A	N/A
	dBm/9 MHz	N/A	N/A	-70.04	-70.18
PRP <sup>Note 3</sup>	dBm/15kHz	-104+TT	-111+TT	-104+TT	-111+TT
$\hat{E}_s/N_{oc}$ <sup>Note 3</sup>	dB	-3+TT	-13+TT	-3+TT	-13+TT
RSRP <sup>Note 3</sup>	dBm/15kHz	-101+TT	-111+TT	-101+TT	-111+TT
Propagation condition		AWGN			
<p>Note 1: OCNG shall be used such that both cells are fully allocated and a constant total transmitted power spectral density is achieved for all OFDM symbols (other than those in the PRS subframes). There is no PDSCH allocated in the subframe transmitting PRS.</p> <p>Note 2: Interference from other cells and noise sources not specified in the test is assumed to be constant over subcarriers and time and shall be modelled as AWGN of appropriate power for <math>N_{oc}</math> to be fulfilled.</p> <p>Note 3: <math>\hat{E}_s/N_{oc}</math>, PRS <math>\hat{E}_s/I_{ot}</math>, RSRP, <math>I_o</math> and PRP levels have been derived from other parameters for information purposes. They are not settable parameters themselves. <math>I_o</math> values are derived in the case that there is no PBCH, PSS or SSS in the OFDM symbols carrying PRS</p>					

Table 9.2.4.5-2: RSTD FDD inter-frequency accuracy requirements for the reported values

	Test 1	Test 2
Lowest reported value	RSTD_6426+TT	RSTD_6438+TT
Highest reported value	RSTD_6468+TT	RSTD_6456+TT

For the overall test to pass, the ratio of successful reported values in each sub-test shall be more than 90% with a confidence level of 95%. In the case that 1.4MHz channel bandwidth is not defined for the operating band under test then Test 1 shall be omitted.

## 9.2.5 TDD-TDD inter frequency RSTD Accuracy

**Editor's note:** This section is incomplete. The following aspects are either missing or not yet determined:

- The Test system uncertainties applicable to this test are undefined
- The Test tolerances applicable to this test are undefined
- Other possible applicability is FFS

### 9.2.5.1 Test purpose

To verify that the Reference Signal Time Difference (RSTD) of TDD-TDD inter-frequency measurement accuracy is within the specified limit for all bands in AWGN channels

### 9.2.5.2 Test applicability

This test applies to all types of E-UTRA TDD UE release 10 and forward. Other possible applicability is FFS.

### 9.2.5.3 Minimum conformance requirements

This RSTD measurement is used for UE positioning purposes.

The accuracy of TDD-TDD inter-frequency RSTD measurement shall meet the requirement defined in the Table 9.2.4.3-1 without DRX as well as for all the DRX cycles specified in TS 36.331 [22].

The accuracy requirements in Table 9.2.4.3-1 are valid under the following conditions:

Conditions defined in TS 36.101 [2] Section 7.3 for reference sensitivity are fulfilled.

PRP  $1,2_{dBm}$  according to clause E.3 for a corresponding Band

There are no measurement gaps overlapping with the PRS subframes in cells belonging to the serving carrier frequency.

The parameter expectedRSTDUncertainty signalled over LPP by E-SMLC as defined in TS 36.355 [4] is less than 5  $\mu$ s.

The normative reference for this requirement is TS 36.133 [23] clause 9.1.10.2 and A.9.8.4.

### 9.2.5.4 Test description

#### 9.2.5.4.1 Initial conditions

Test Environment: Normal; as defined in TS 36.508 [18] clause 4.1.

Frequencies to be tested: Mid Range, as defined in TS 36.508 [18] clause 4.3.1.2.

Channel bandwidth to be tested: 1.4 MHz (Test 1) and 10 MHz (Test 2). In the case that 1.4MHz channel bandwidth is not defined for the operating band under test, as defined in TS 36.101 [2] clause 5.6.1, then this part of the test shall be omitted.

1. Connect the SS and AWGN noise sources to the UE antenna connector or antenna connectors as shown in Annex A, Figure A.3.
2. The general test parameter settings are set up according to Table 9.2.5.4.1-1.
3. Propagation conditions are set according to clause 4.7.2.1.
4. Message contents are defined in clause 9.2.5.4.3.
5. Two cells are on the different carrier frequencies. Cell 1 is the serving cell and OTDOA assistance data reference cell; Cell 2 is the neighbour cell. The assistance data neighbour cell list includes in total 15 cells, where 14 of the cells are not simulated (dummy cells; as defined in 3GPP TS 37.571-5 [20], clause 7.2.2).
6. The true RSTD (which is the receive time difference for frame 0 between the two cells as seen at the UE antenna connector) is set to 92 Ts (2.99  $\mu$ s) between neighbour cell 2 and serving cell 1.

Note that the related expectedRSTD values to be signalled over LPP are defined in Table 9.2.5.4-1.

7. The gap pattern configuration # 0 as defined in Table 8.1.2.1-1 in 3GPP TS 36.133 [23] is configured and does not overlap with PRS subframes of Cell 1.

Table 9.2.5.4.1-1: General Test Parameters for inter-frequency RSTD Tests for E-UTRAN TDD-TDD

Parameter	Unit	Value		Comment
		Test1	Test2	
PCFICH/PDCCH/PHICH parameters		R.8 TDD	R.6 TDD	As specified in TS 36.521-3 [25] clause A.2.2
OCNG Patterns defined in TS 36.521-3 [25] clause D.1.2		OP.4 TDD	OP.2 TDD	OCNG shall be used such that both cells are fully allocated and a constant total transmitted power spectral density is achieved for all OFDM symbols (other than those in the PRS subframes). There is no PDSCH allocated in the subframe transmitting PRS.
Reference cell		Cell 1		Cell 1 on RF channel number 1
Neighbour cell		Cell 2		Cell 2 on RF channel number 2
E-UTRA RF Channel Number		1,2		Two TDD carrier frequencies are used.
Channel Bandwidth ( $BW_{channel}$ )	MHz	1.4	10	
PRS Bandwidth <sup>Note 2</sup>	RB	6	50	
GapOffset		15	14	For Cell 1
Gap Pattern ID		0		For Cell 1
Special subframe configuration		6		As specified in table 4.2-1 in TS 36.211 [26]. The same configuration in both cells.
Uplink-downlink configuration		3	1	As specified in table 4.2-2 in TS 36.211 [26] and table 9.1.2.3-2. The same configuration in both cells.
PRS configuration Index $I_{PRS}$ Note 2		Cell 1: 5 Cell 2: 15		As defined in 3GPP TS 36.211 [26]
PRS subframe offset		10		For Cell 2
Number of consecutive positioning downlink subframes $N_{PRS}$ <sup>Note 2</sup>		6	1	As defined in 3GPP TS 36.211 [26]
prs-MutingInfo <sup>Note 2</sup>		Cell1:'11110000' Cell2:'11110000'		See section 6.5.1.2 in 3GPP TS 36.355 [4] for more information
Cell ID <sup>Note 2</sup>		Cell 1: 0 Cell 2: 1		
expectedRSTD <sup>Note 1</sup>	$\mu$ s	3		
expectedRSTDUncertainty <sup>Note 1</sup>	$\mu$ s	5		
CP length <sup>Note 2</sup>		Normal		
DRX		OFF		
Radio frame transmit time difference between cells (cell 2 TX time – cell 1 TX time) <sup>Note 3</sup>	$\mu$ s	3		Synchronous cells
Number of cells provided in OTDOA assistance data		16		The list includes the reference cell (received in <i>OTDOA-ReferenceCellInfo</i> [4]) on RF channel 1 and 15 other cells on RF channel 2, all received in <i>OTDOA-ProvideAssistanceData</i> [4].
$T_{RSTD\ InterFreq\ TDD, E-UTRAN}$ <sup>Note 4</sup>	ms	5120		Derived according to the RSTD measurement requirements specified in Section 8.1.2.6.1 in TS 36.133 [23].
<p>NOTE 1: Parameters “expected RSTD” and “expected RSTDUncertainty” are not settable parameters. These are parameters signalled in LPP only. For the values to be used in LPP see Table 9.2.5.4.3-4 and TS 37.571-5 [20], clause 7.2.2.</p> <p>NOTE 2: Parameters “PRS Bandwidth”, “PRS configuration index”, “Number of consecutive positioning downlink subframes”, “prs-MutingInfo”, “Cell ID” and “CP length” are settable parameters and also parameters signalled in LPP. For all the values to be used in LPP see Table 9.2.5.4.3-4 and TS 37.571-5 [20], clause 7.2.2.</p> <p>NOTE 3: The parameter “Radio frame transmit time difference between cells (cell 2 TX time – cell 1 TX time)” is not a settable parameter but is used to set the “true RSTD” values in step 6 of clause 9.2.5.4.1.</p> <p>NOTE 4: The parameter “<math>T_{RSTD\ InterFreq\ TDD, E-UTRAN}</math>” is not a settable parameter but is used to set the LPP “responseTime” value in Table 9.2.5.4.3-3. The value of the LPP responseTime IE is set to <math>T_{RSTD\ InterFreq\ TDD, E-UTRAN} + \Delta T</math> ms, where <math>\Delta T = 150</math> ms, giving a value of 5270 ms. This is rounded up to the next allowed LPP value of 6 seconds.</p>				

## 9.2.5.4.2 Test procedure

The test consists of a set-up period and a measurement period. Cell 1 and Cell 2 are both active during the complete test. The beginning of the measurement period shall be aligned with the first PRS positioning subframe of a positioning occasion in the reference cell.

NOTE: The information on when PRS is muted is conveyed to the UE using PRS muting information in the OTDOA assistance data.

The OTDOA-RequestLocationInformation message and the OTDOA assistance data as defined in clause 9.2.5.4.3 shall be provided to the UE during the set-up period. The last TTI containing the OTDOA-RequestLocationInformation message shall be provided to the UE  $\Delta T$  ms before the start of the measurement period, where  $\Delta T = 150$  ms is the maximum processing time of the OTDOA-RequestLocationInformation message and the OTDOA assistance data in the UE.

1. Ensure that the UE is in state Generic RB Established State 3A-RF according to 3GPP TS 36.508 [18] clause 7.2A.3.
2. The SS shall send a RESET UE POSITIONING STORED INFORMATION message.
3. Set the parameters according to Table 9.2.5.5-1 as appropriate. Propagation conditions are set according to clause 4.7.2.1.
4. The SS shall transmit an RRCConnectionReconfiguration message with the measurement gap configuration.
5. The UE shall transmit RRCConnectionReconfigurationComplete message.
6. The SS shall send a LPP PROVIDE ASSISTANCE DATA message, including the *OTDOA-ProvideAssistanceData* IE.
7. The SS shall send a LPP REQUEST LOCATION INFORMATION message, including the *OTDOA-RequestLocationInformation* IE such that the UE receives the message  $\Delta T$  ms before the start of measurement period, where  $\Delta T = 150$  ms.
8. The UE shall transmit a LPP PROVIDE LOCATION INFORMATION message, including the *OTDOA-ProvideLocationInformation* IE.
9. If the UE message at step 8 includes the *ackRequested* IE set to TRUE, the SS shall send a LPP acknowledgement message.
10. The SS shall check the *rstd* value for Cell 2 in the *OTDOA-SignalMeasurementInformation* IE according to Table 9.2.5.5-2.
11. Repeat step 2-10 until the confidence level according to Annex D is achieved.
12. Repeat step 1-11 for each sub-test in Table 9.2.5.5-1 as appropriate.

## 9.2.5.4.3 Message contents

Table 9.2.5.4.3-1: RESET UE POSITIONING STORED INFORMATION

Derivation Path: 36.509 clause 6.9			
Information Element	Value/remark	Comment	Condition
UE Positioning Technology	0 0 0 0 0 0 1	OTDOA	

**Table 9.2.5.4.3-2: MeasGapConfig-GP1: TDD-TDD inter-frequency RSTD Accuracy**

Derivation Path: TS 36.508 [18] clause 4.6.6, Table 4.6.6-1A: MeasGapConfig-GP1			
Information Element	Value/remark	Comment	Condition
MeasGapConfig-GP1 ::= CHOICE {			
setup SEQUENCE {			
gapOffset CHOICE {			
gp0	15 (Test 1) 14 (Test 2)	TGRP = 40 ms	
}			
}			
}			

**Table 9.2.5.4.3-3: LPP RequestLocationInformation**

Derivation Path: 36.355 clause 6.2			
Information Element	Value/remark	Comment	Condition
LPP-Message ::= SEQUENCE {			
transactionID SEQUENCE {			
initiator	locationServer		
transactionNumber	1		
}			
endTransaction	FALSE		
sequenceNumber	Not present		
acknowledgement	Not present		
lpp-MessageBody CHOICE {			
c1 CHOICE {			
requestLocationInformation SEQUENCE {			
criticalExtensions CHOICE {			
c1 CHOICE {			
requestLocationInformation-r9 SEQUENCE {			
commonIEsRequestLocationInformation SEQUENCE {			
locationInformationType	locationMeasurementsRequired		
triggeredReporting	Not present		
periodicalReporting	Not present		
additionalInformation	onlyReturnInformationRequested		
qos SEQUENCE {			
horizontalAccuracy	Not present		
verticalCoordinateRequest	FALSE		
verticalAccuracy	Not present		
responseTime	6	See Note 4 of Table 9.2.5.4.1-1	
velocityRequest	FALSE		
}			
environment	Not present		
locationCoordinateTypes	Not present		
velocityTypes	Not present		
}			
}			
}			
}			
}			
}			
}			
}			

Table 9.2.5.4.3-4: LPP ProvideAssistanceData

Derivation Path: 36.355 clause 6.2			
Information Element	Value/remark	Comment	Condition
LPP-Message ::= SEQUENCE {			
transactionID SEQUENCE {			
Initiator	locationServer		
transactionNumber	(0..255)		
}			
endTransaction	TRUE		
sequenceNumber	Not present		
acknowledgement	Not present		
lpp-MessageBody CHOICE {			
c1 CHOICE {			
provideAssistanceData SEQUENCE {			
criticalExtensions CHOICE {			
c1 CHOICE {			
provideAssistanceData-r9 SEQUENCE {			
commonIEs ProvideAssistanceData	Not present		
a-gnss-ProvideAssistanceData	Not present		
otdoa-ProvideAssistanceData SEQUENCE {			
otdoa-ReferenceCellInfo	As defined in TS 37.571-5 [20], clause 7.2.2.		
otdoa-NeighbourCellInfo	As defined in TS 37.571-5 [20], clause 7.2.2.		
otdoa-Error	Not present		
}			
epdu-ProvideAssistanceData	Not present		
}			
}			
}			
}			
}			
}			

Table 9.2.5.4.3-5: LPP ProvideLocation Information

Derivation Path: 36.355 clause 6.2			
Information Element	Value/remark	Comment	Condition
LPP-Message ::= SEQUENCE {			
transactionID SEQUENCE {			
initiator	locationServer		
transactionNumber	1		
}			
endTransaction	TRUE		
sequenceNumber	(0..255)		
acknowledgement			
lpp-MessageBody CHOICE {			
c1 CHOICE {			
provideLocationInformation SEQUENCE {			
criticalExtensions CHOICE {			
c1 CHOICE {			
provideLocationInformation-r9 SEQUENCE {			
commonEsProvideLocationInformation	Not present.		
a-gnss-ProvideLocationInformation	Not present		
otdoa-ProvideLocationInformation			
SEQUENCE {			
otdoaSignalMeasurementInformation			
SEQUENCE {			
systemFrameNumber			
physCellIdRef	Cell 1		
cellGlobalIdRef			
earfcnRef			
referenceQuality			
neighbourMeasurementList			
SEQUENCE (SIZE(1)) {			
physCellIdNeighbor	Cell 2		
cellGlobalIdNeighbour			
earfcnNeighbour	RF channel 2		
rstd	Set according to Table 9.2.5.5-2 for each specific test		
rstd-Quality			
}			
}			
}			
otdoa-Error	May be present with error reason 'undefined' or 'attemptedButUnableToMeasureSomeNeighbourCells'		
}			
ecid-ProvideLocationInformation	Not present		
epdu-ProvideLocationInformation	Not present		
}			
}			
}			
}			

### 9.2.5.5 Test requirement

Table 9.2.5.5-1 defines the primary level settings including test tolerances for all tests.

The RSTD TDD-TDD inter frequency measurement accuracy test shall meet the reported values in Table 9.2.5.5-2.



**Table 9.2.5.5-1: Cell Specific Test Parameters for inter frequency RSTD Tests for E-UTRAN TDD-TDD**

Parameter	Unit	Test1		Test2	
		Cell1	Cell2	Cell1	Cell2
E-UTRAN Channel Number		1	2	1	2
PBCH_RA	dB	0			
PBCH_RB					
PSS_RA					
SSS_RA					
PCFICH_RB					
PHICH_RA					
PHICH_RB					
PDCCH_RA					
PDCCH_RB					
OCNG_RA <sup>Note 1</sup>					
OCNG_RB <sup>Note 1</sup>					
PRS_RA	dB	-3	0	-3	0
$N_{oc}$ <sup>Note 2</sup>	dBm/15 kHz	-98			
$PRS \hat{E}_s / N_{oc}$	dB	-6	-13	-6	-13
$PRS \hat{E}_s / I_{ot}$ <sup>Note 3</sup>	dB	-6+TT	-13+TT	-6+TT	-13+TT
$I_o$ <sup>Note 3</sup>	dBm/1.08 MHz	-79.25	-79.39	N/A	N/A
	dBm/9 MHz	N/A	N/A	-70.04	-70.18
PRP <sup>Note 3</sup>	dBm/15kHz	-104+TT	-111+TT	-104+TT	-111+TT
$\hat{E}_s / N_{oc}$ <sup>Note 3</sup>	dB	-3	-13	-3	-13
RSRP <sup>Note 3</sup>	dBm/15kHz	-101	-111	-101	-111
Propagation condition		AWGN			
<p>Note 1: OCNG shall be used such that both cells are fully allocated and a constant total transmitted power spectral density is achieved for all OFDM symbols (other than those in the PRS subframes). There is no PDSCH allocated in the subframe transmitting PRS.</p> <p>Note 2: Interference from other cells and noise sources not specified in the test is assumed to be constant over subcarriers and time and shall be modelled as AWGN of appropriate power for <math>N_{oc}</math> to be fulfilled.</p> <p>Note 3: <math>\hat{E}_s / N_{oc}</math>, <math>PRS \hat{E}_s / I_{ot}</math>, <math>I_o</math>, RSRP and PRP levels have been derived from other parameters for information purposes. They are not settable parameters themselves. <math>I_o</math> values are derived in the case that there is no PBCH, PSS or SSS in the OFDM symbols carrying PRS.</p>					

**Table 9.2.5.5-2: RSTD TDD inter-frequency accuracy requirements for the reported values**

	Test 1	Test 2
Lowest reported value	RSTD_6426+TT	RSTD_6438+TT
Highest reported value	RSTD_6468+TT	RSTD_6456+TT

For the overall test to pass, the ratio of successful reported values in each sub-test shall be more than 90% with a confidence level of 95%. In the case that 1.4MHz channel bandwidth is not defined for the operating band under test then Test 1 shall be omitted.

## 10.1 FDD RSTD Measurement Reporting Delay for Carrier Aggregation

Editor's note: This test case is incomplete. The following aspects are either missing or not yet determined:

- The connection diagram is undefined.
- Further study and discussion with RAN 4 is needed to determine the meaning of “/or” in the test procedure and how to test the case where “the UE is expected to report RSTD measurements performed on PCC and/or on SCC”.
- The Test system uncertainties applicable to this test are undefined.
- The Test tolerances applicable to this test are undefined.

### 10.1.1 Test purpose

To verify that the RSTD measurement reporting delay meets the requirements in an environment with fading propagation conditions. This test case verifies the measurement period requirements for RSTD measurements performed on the secondary component carrier and also the measurement period requirements for RSTD measurements performed on both the primary and secondary component carriers.

### 10.1.2 Test applicability

This test applies to all types of E-UTRA FDD UE release 10 and forward that supports UE-assisted OTDOA for Carrier Aggregation.

### 10.1.3 Minimum conformance requirements

#### 10.1.3.1 Measurements on the secondary component carrier

The RSTD measurements when all cells are on the configured secondary component carrier shall meet all applicable requirements (FDD) specified in TS 36.133 [23] section 8.1.2.5, i.e., E-UTRAN intra-frequency RSTD measurement period applies, regardless of whether the SCell on the corresponding frequency is activated or deactivated by the MAC-CE commands as specified in 3GPP TS 36.321 [34].

#### 10.1.3.2 Measurements on both primary component carrier and secondary component carrier

The RSTD measurements of cells on both primary component carrier and configured secondary component carrier shall meet all applicable requirements (FDD) specified in TS 36.133 [23] section 8.1.2.6, i.e., E-UTRAN inter-frequency RSTD measurement period applies regardless of whether the SCell on the corresponding frequency is activated or deactivated by the MAC-CE commands as specified in 3GPP TS 36.321 [34], with the following exception

- the number of PRS positioning occasions is as specified in Table 10.1.3.2-1 shall apply.

**Table 10.1.3.2-1: Number of PRS positioning occasions within measurement period**

Positioning subframe configuration period $T_{PRS}$	Number of PRS positioning occasions $M$
160 ms	32
>160 ms	16

The normative reference for this requirement is TS 36.133 [23] clause 8.4.3, 8.4.4 and A.8.17.1.

## 10.1.4 Test description

### 10.1.4.1 Initial conditions

Test Environment: Normal; as defined in TS 36.508 [18] clause 4.1.

Frequencies to be tested: Mid Range, as defined in TS 36.508 [18] clause 4.3.1.1.

Channel bandwidth to be tested: 10 MHz as defined in TS 36.508 [18] clause 4.3.1.

1. Connect the SS, faders and AWGN noise sources to the UE antenna connector or antenna connectors as shown in Annex A, Figure FFS.
2. The general test parameter settings are set up according to Table 10.1.4.1-1.
3. Propagation conditions are set according to clause 4.7.2.1.
4. Message contents are defined in clause 10.1.4.3.
5. In the tests, there are two configured component carriers: PCC and SCC, and three synchronized cells: Cell 1, Cell 2 and Cell 3. Cell 1 is PCell on the PCC, Cell 2 is an active SCell on the SCC, and Cell 3 is a neighbour cell on the SCC. In both tests, Cell 2 is the OTDOA assistance data reference cell. The assistance data neighbour cell list includes in total 15 cells, where 14 of the cells are not simulated (dummy cells; as defined in 3GPP TS 37.571-5 clause 7.3.2) for Test 1 and where 13 of the cells are not simulated for Test 2. PCell (Cell 1) is the cell used for connection setup with the power level and mapping set according to TS 36.521-1 [24] Annex C.0 and C.1 as appropriate for this test. Cell 2 and Cell 3 are powered OFF.
6. The true RSTD (which is the receive time difference for frame 0 between two cells as seen at the UE antenna connector) is set to 0 Ts (0  $\mu$ s) between neighbour Cell 3 and OTDOA assistance data reference cell, Cell 2; and set to 92 Ts (about 3  $\mu$ s) between neighbour Cell 1 and OTDOA assistance data reference cell, Cell 2.

**Table 10.1.4.1-1: General test parameters for E-UTRAN FDD RSTD measurement reporting delay under fading propagation conditions for Carrier Aggregation**

Parameter	Unit	Value		Comment
		Test 1	Test 2	
PCell		Cell 1		PCell is on RF channel 1 (PCC).
SCell		Cell 2		SCell on RF channel 2 (SCC). Cell 2 is the assistance data reference cell.
Other neighbour cell		Cell 3		Neighbour cell on RF channel 2 (SCC).
PCFICH/PDCCH/PHICH parameters		DL Reference Measurement Channel R.6 FDD		As specified in TS 36.521-3 [25] clause A.2.1
Channel Bandwidth (BW <sub>channel</sub> )	MHz	10		
PRS Transmission Bandwidth <sup>Note 2</sup>	RB	50		PRS are transmitted over the system bandwidth
PRS configuration index $I_{PRS}$ <sup>Note 2</sup>		171 for all cells on PCC 181 for all cells on SCC		This corresponds to periodicity of 320 ms and PRS subframe offset of $I_{PRS} - 160$ DL subframes, as defined in 3GPP TS 36.211 [26], Table 6.10.4.3-1
Number of consecutive downlink positioning subframes $N_{PRS}$ <sup>Note 2</sup>		1		As defined in 3GPP TS 36.211 [26]. The number of subframes in a positioning occasion
Physical cell ID PCI <sup>Note 2</sup>		(PCI of Cell 2 – PCI of Cell 3) mod 6 = 0		The PCI of Cell 1 is selected randomly. PCIs of Cell 2 and Cell 3 are selected randomly such that the relative subcarrier shifts of PRS patterns among these cells are as given by the condition.
CP length <sup>Note 2</sup>		Normal		
DRX		ON		DRX parameters are further specified in Table 10.1.4.1-2
Maximum radio frame transmit time offset between the cells at the UE antenna connector <sup>Note 3</sup>	μs	3		Synchronous cells
Expected RSTD <sup>Note 1</sup>	μs	3		The expected RSTD is what is expected at the receiver. The corresponding parameter in the OTDOA assistance data specified in TS 36.355 [4] is the expectedRSTD indicator
Expected RSTD uncertainty <sup>Note 1</sup>	μs	5		The corresponding parameter in the OTDOA assistance data specified in TS 36.355 [4] is the expectedRSTD-Uncertainty index
Number of cells provided in OTDOA assistance data		16 cells in total		The list includes the reference cell and 15 other cells. Cell 1 (when included) appears at random places in the first half of the neighbour cell list in the OTDOA assistance data. Cell 3 always appears at random places in the second half of the list
		OTDOA neighbour cells include Cell 3 and other 14 cells on SCC	OTDOA neighbour cells include Cell 1 and other 7 cells on PCC, and Cell 3 and other 6 cells on SCC	

prs-SubframeOffset <sup>Note 3</sup>		Cells on PCC: 310 Cells on SCC, except reference cell: 0		Subframe offset, counted in full subframes. The corresponding parameter in the OTDOA assistance data is prs-SubframeOffset specified in TS 36.355 [4]
slotNumberOffset <sup>Note 3</sup>		Cells on PCC: 0 Cells on SCC, except reference cell: 0		The slot number offset at the transmitter between a neighbour cell and the assistance data reference cell. The corresponding parameter in the OTDOA assistance data is slotNumberOffset specified in TS 36.355 [4].
PRS muting info <sup>Note 2</sup>		Cell 1: '11110000' Cell 2: '00001111' Cell 3: '11110000'	Cell 1: '1111111100000000' Cell 2: '0000000111111111' Cell 3: '1111111100000000'	Corresponds to prs-MutingInfo defined in TS 36.355 [4]
T1	S	3		The length of the time interval from the beginning of each test
T2	S	1.28	2.48	The length of the time interval that follows immediately after time interval T1
T3	S	1.28	2.48	The length of the time interval that follows immediately after time interval T2
Note 1:	Parameters "Expected RSTD" and "Expected RSTD uncertainty" are not settable parameters. These are parameters signalled in LPP only. For the values to be used in LPP see Table 10.1.4.3-4 and TS 37.571-5 [20], clause 7.3.2.			
Note 2:	Parameters "PRS Transmission Bandwidth", "PRS configuration index", "Number of consecutive downlink positioning subframes", "Physical cell ID PCI", "CP length", "prs-SubframeOffset", "slotNumberOffset" and "PRS muting info" are settable parameters and also parameters signalled in LPP. The values to be used for "Physical cell ID PCI" are as follows: Cell 1: 0, Cell 2: 6, Cell 3: 12. For the values to be used in LPP see Table 10.1.4.3-4 and TS 37.571-5 [20], clause 7.3.2.			
Note 3:	The parameter "Maximum radio frame transmit time offset between the cells at the UE antenna connector" is not a settable parameter but is used to set the "true RSTD" values in step 6 of clause 10.1.4.1.			

**Table 10.1.4.1-2: DRX parameters for E-UTRAN FDD RSTD measurement reporting delay under fading propagation conditions for Carrier Aggregation**

Field	Value	Comment
onDurationTimer	psf1	As specified in 3GPP TS 36.331 [22], clause 6.3.2
drx-InactivityTimer	psf1	
drx-RetransmissionTimer	sf1	
longDRX-CycleStartOffset	sf320	
shortDRX	Disable	

### 10.1.4.2 Test procedure

The test case includes two tests. Test 1 is designed for the scenario where the UE receives OTDOA assistance data with cells on SCC, and the UE is expected to report RSTD measurements performed on SCC only. Test 2 is designed for the scenario where the UE receives OTDOA assistance data with cells on PCC and SCC, and the UE is expected to report RSTD measurements performed on PCC and/or on SCC.

Each test consists of three consecutive time intervals, with duration of T1, T2 and T3 defined in Table 10.1.4.1-1. Cell 1 is active in T1, T2 and T3, whilst Cell 2 is active only in T2 and T3, and Cell 3 is active only during T2. The beginning of the time interval T2 shall be aligned [5] ms before the first PRS positioning subframe of a positioning occasion in the OTDOA assistance data reference cell, where [5] ms is the necessary test tolerance. Cell 1 transmits PRS in T2, while Cell 2 transmits PRS only in T3, and Cell 3 transmits PRS only in T2.

NOTE: The information on when PRS is muted is conveyed to the UE using PRS muting information in the OTDOA assistance data.

The OTDOA-RequestLocationInformation message and the OTDOA assistance data as defined in clause 10.1.4.3 shall be provided to the UE during T1. The last TTI containing the OTDOA-RequestLocationInformation message shall be provided to the UE  $\Delta T$  ms before the start of T2, where  $\Delta T = 150$  ms is the maximum processing time of the OTDOA-RequestLocationInformation message and the OTDOA assistance data.

1. Ensure that the UE is in state Generic RB Established State 3A-RF according to 3GPP TS 36.508 [18] clause 7.2A.3.
2. Configure Cell 2 and Cell 3 on the SCC according to TS 36.521-1 [24] Annex C.0 and C.1 for all downlink physical channels except PHICH.
3. The SS shall configure the SCell (Cell 2) on the SCC as per TS 36.508 [18] clause 5.2A.4.
4. The SS activates the SCell (Cell 2) by sending the Activation/Deactivation MAC control element according to TS 36.321 [34] clauses 5.13 and 6.1.3.8. Wait for at least 2 seconds as per TS 36.133 [23] clause 8.3.3.2.
5. The SS shall send a RESET UE POSITIONING STORED INFORMATION message.
6. Set the parameters according to Table 10.1.5-1. Propagation conditions are set according to clause 4.7.2.2 (ETU30).
7. T1 starts.
8. The SS shall transmit an RRCConnectionReconfiguration message with the DRX configuration.
9. The UE shall transmit RRCConnectionReconfigurationComplete message.
10. The SS shall send a LPP PROVIDE ASSISTANCE DATA message, including the *OTDOA-ProvideAssistanceData* IE. The position of neighbour Cell 3 in the *OTDOA-NeighbourCellInfoList* is randomly selected to be in the last 8 elements of the sequence for Test 1 and Test 2, and the position of neighbour Cell 1 is randomly selected to be in the first 7 elements of the sequence for Test 2, as described in 3GPP TS 37.571-5 [20], clause 7.3.2.
11. The SS shall send a LPP REQUEST LOCATION INFORMATION message, including the *OTDOA-RequestLocationInformation* IE such that the UE receives the message  $\Delta T$  ms before the start of T2, where  $\Delta T = 150$  ms.
12. When T1 expires, the SS shall switch the power setting from T1 to T2 as specified in Table 10.1.5-2.
13. When T2 expires, the SS shall switch the power setting from T2 to T3 as specified in Table 10.1.5-2.
14. The UE shall transmit a LPP PROVIDE LOCATION INFORMATION message including the *OTDOA-ProvideLocationInformation* IE within the response time (see clause 4.7.3) specified in clause 10.1.5.

For Test 1 the UE shall perform and report the RSTD measurement for Cell 3 with respect to the reference cell in the OTDOA assistance data, Cell 2. If the UE transmits an *OTDOA-ProvideLocationInformation* IE including the *rstd* field for Cell 3 within the response time then the number of successful tests is increased by one. If the UE fails to report the *OTDOA-ProvideLocationInformation* IE with the *rstd* field included within the response time then the number of failure tests is increased by one.

For Test 2 the UE shall perform and report the RSTD measurements for both Cell 1 and Cell 3 with respect to the reference cell in the OTDOA assistance data, Cell 2. If the UE transmits an *OTDOA-ProvideLocationInformation* IE including the *rstd* field for both Cell 1 and Cell 3 within the response time then the number of successful tests is increased by one. If the UE fails to report the *OTDOA-ProvideLocationInformation* IE with both the *rstd* fields included within the response time then the number of failure tests is increased by one.

15. If the UE message at step 14 includes the *ackRequested* IE set to TRUE, the SS shall send a LPP acknowledgement message.
16. Repeat steps 5-15 until the confidence level according to Annex D is achieved. For each iteration, at step 10 change the random positions of the Cell 3 and Cell 1 (for Test 2 only) in the *OTDOA-NeighbourCellInfoList*.

17. Repeat from clause 10.1.4.1 for Test 2.

### 10.1.4.3 Message contents

**Table 10.1.4.3-1: RESET UE POSITIONING STORED INFORMATION**

Derivation Path: 36.509 clause 6.9			
Information Element	Value/remark	Comment	Condition
UE Positioning Technology	0 0 0 0 0 0 1	OTDOA	

**Table 10.1.4.3-2: MAC-MainConfig-RBC: FDD RSTD Measurement Reporting Delay for Carrier Aggregation**

Derivation Path: TS 36.508 [18] clause 4.8.2.1.5, Table 4.8.2.1.5-1 MAC-MainConfig-RBC			
Information Element	Value/remark	Comment	Condition
MAC-MainConfig-RBC ::= SEQUENCE {			
drx-Config CHOICE {			
setup SEQUENCE {			
onDurationTimer	psf1		
drx-InactivityTimer	psf1		
drx-RetransmissionTimer	sf1		
longDRX-CycleStartOffset CHOICE {			
sf320	0		
}			
shortDRX	Not present		
}			
}			
}			

Table 10.1.4.3-3: LPP RequestLocationInformation

Derivation Path: 36.355 clause 6.2			
Information Element	Value/remark	Comment	Condition
LPP-Message ::= SEQUENCE {			
transactionID SEQUENCE {			
Initiator	locationServer		
transactionNumber	1		
}			
endTransaction	FALSE		
sequenceNumber	Not present		
acknowledgement	Not present		
lpp-MessageBody CHOICE {			
c1 CHOICE {			
requestLocationInformation SEQUENCE {			
criticalExtensions CHOICE {			
c1 CHOICE {			
requestLocationInformation-r9 SEQUENCE {			
commonIEsRequestLocationInformation SEQUENCE {			
locationInformationType	locationMeasurementsRequired		
triggeredReporting	Not present		
periodicalReporting	Not present		
additionalInformation	onlyReturnInformationRequested		
qos SEQUENCE {			
horizontalAccuracy	Not present		
verticalCoordinateRequest	FALSE		
verticalAccuracy	Not present		
responseTime	Test 1: 3 Test 2: 6	See clause 10.1.5	
velocityRequest	FALSE		
}			
environment	Not present		
locationCoordinateTypes	Not present		
velocityTypes	Not present		
}			
a-gnss-RequestLocationInformation	Not present		
otdoa-RequestLocationInformation SEQUENCE {			
assistanceAvailability	FALSE		
}			
ecid-RequestLocationInformation	Not present		
epdu-RequestLocationInformation	Not Present		
}			
}			
}			
}			



Table 10.1.4.3-4: LPP ProvideAssistanceData

Derivation Path: 36.355 clause 6.2			
Information Element	Value/remark	Comment	Condition
LPP-Message ::= SEQUENCE {			
transactionID SEQUENCE {			
Initiator	locationServer		
transactionNumber	(0..255)		
}			
endTransaction	TRUE		
sequenceNumber	Not present		
acknowledgement	Not present		
lpp-MessageBody CHOICE {			
c1 CHOICE {			
provideAssistanceData SEQUENCE {			
criticalExtensions CHOICE {			
c1 CHOICE {			
provideAssistanceData-r9 SEQUENCE {			
commonIEs ProvideAssistanceData	Not present		
a-gnss-ProvideAssistanceData	Not present		
otdoa-ProvideAssistanceData SEQUENCE {			
otdoa-ReferenceCellInfo	As defined in TS 37.571-5 [20], clause 7.3.2.		
otdoa-NeighbourCellInfo	As defined in TS 37.571-5 [20], clause 7.3.2.		
otdoa-Error	Not present		
}			
epdu-ProvideAssistanceData	Not present		
}			
}			
}			
}			
}			
}			

Table 10.1.4.3-5: LPP ProvideLocation Information

Derivation Path: 36.355 clause 6.2			
Information Element	Value/remark	Comment	Condition
LPP-Message ::= SEQUENCE {			
transactionID SEQUENCE {			
Initiator	locationServer		
transactionNumber	1		
}			
endTransaction	TRUE		
sequenceNumber	(0..255)		
acknowledgement			
lpp-MessageBody CHOICE {			
c1 CHOICE {			
provideLocationInformation SEQUENCE {			
criticalExtensions CHOICE {			
c1 CHOICE {			
provideLocationInformation-r9 SEQUENCE {			
commonIEsProvideLocationInformation	Not present.		
a-gnss-ProvideLocationInformation	Not present		
otdoa-ProvideLocationInformation SEQUENCE {			
otdoaSignalMeasurementInformation SEQUENCE {			
systemFrameNumber			
physCellIdRef	Cell 2		
cellGlobalIdRef			
earfcnRef			
referenceQuality			
neighbourMeasurementList SEQUENCE (SIZE(n)) {			
physCellIdNeighbour	Cell 3		
cellGlobalIdNeighbour			
earfcnNeighbour			
rstd	Present		
rstd-Quality			
}			
neighbourMeasurementList SEQUENCE (SIZE(n)) {			
physCellIdNeighbour	Cell 1	Test 2 only	
cellGlobalIdNeighbour			
earfcnNeighbour			
rstd	Present	Test 2 only	
rstd-Quality			
}			
}			
otdoa-Error	Maybe present with error reason 'undefined' or 'attemptedButUnableToMeasureSomeNeighbourCells'		
}			
ecid-ProvideLocationInformation	Not present		
epdu-ProvideLocationInformation	Not present		
}			
}			
}			
}			
}			
}			

## 10.1.5 Test requirement

Table 10.1.5-1 and 10.1.5-2 define the primary level settings including test tolerances for the tests.

**Table 10.1.5-1: Cell-specific test parameters for E-UTRAN FDD RSTD measurement reporting delay under fading propagation conditions during T1 for Carrier Aggregation**

Parameter	Unit	Cell 1	Cell 2	Cell 3
E-UTRA RF Channel Number		1	N/A	N/A
OCNG patterns defined in TS 36.521-3 [25] clause D.1.1		OP.5 FDD	N/A	N/A
PBCH_RA	dB	0	N/A	N/A
PBCH_RB				
PSS_RA				
SSS_RA				
PCFICH_RB				
PHICH_RA				
PHICH_RB				
PDCCH_RA				
PDCCH_RB				
OCNG_RA <sup>Note 1</sup>				
OCNG_RB <sup>Note 1</sup>				
PRS_RA				
$N_{oc}$ <sup>Note 3</sup>	dBm/15 kHz	-95	N/A	N/A
$PRS \hat{E}_s/N_{oc}$	dB	-Infinity	-Infinity	-Infinity
$I_o$ <sup>Note 4</sup>	dBm/9 MHz	-64.21	N/A	N/A
$\hat{E}_s/N_{oc}$	dB	0	-Infinity	-Infinity
Propagation Condition		ETU30		
<p>Note 1: OCNG shall be used such that active cell (Cell 1) is fully allocated and a constant total transmitted power spectral density is achieved for all OFDM symbols.</p> <p>Note 2: The resources for uplink transmission are assigned to the UE prior to the start of time period T2.</p> <p>Note 3: Interference from other cells and noise sources not specified in the test are assumed to be constant over subcarriers and time and shall be modelled as AWGN of appropriate power for <math>N_{oc}</math> to be fulfilled.</p> <p>Note 4: <math>I_o</math> levels have been derived from other parameters and are given for information purpose. These are not settable test parameters.</p>				

**Table 10.1.5-2: Cell-specific test parameters for E-UTRAN FDD RSTD measurement reporting delay under fading propagation conditions during T2 and T3 for Carrier Aggregation**

Parameter	Unit	Cell 1		Cell 2		Cell 3	
		T2	T3	T2	T3	T2	T3
E-UTRA RF Channel Number		1		2		2	
OCNG patterns defined in TS 36.521-3 [25] clause D.1.1		OP.5 FDD		OP.6 FDD		OP.6 FDD	N/A
PBCH_RA	dB	0		0		0	N/A
PBCH_RB							
PSS_RA							
SSS_RA							
PCFICH_RB							
PHICH_RA							
PHICH_RB							
PDCCH_RA							
PDCCH_RB							
OCNG_RA <sup>Note 1</sup>							
OCNG_RB <sup>Note 1</sup>							
PRS_RA	dB	[FFS]	N/A	N/A	0	0	N/A
$N_{oc}$ <sup>Note 3</sup>	dBm/15 kHz	-98	-98	-98	-95	-98	-95
$PRS \hat{E}_s/N_{oc}$	dB	-4 + TT	-Infinity	-Infinity	-10 + TT	-11 + TT	-Infinity
$PRS \hat{E}_s/I_{ot}$ <sup>Note 4</sup>	dB	-4 + TT	-Infinity	-Infinity	-10 + TT	-11 + TT	-Infinity
$I_o$ <sup>Note 4</sup>	dBm/9 MHz	-69.87	[FFS]	[FFS]	-67.15	-70.16	N/A
PRP <sup>Note 4</sup>	dBm/15 kHz	-102 + TT	-Infinity	-Infinity	-105 + TT	-109 + TT	-Infinity
RSRP <sup>Note 4</sup>	dBm/15 kHz	[FFS]+ TT	[FFS]+ TT	-105 + TT	-105 + TT	-109 + TT	-Infinity
$\hat{E}_s/N_{oc}$	dB	[FFS]	[FFS]	[FFS]	[FFS]	[FFS]	-Infinity
Propagation Condition		ETU30					
<p>Note 1: OCNG shall be used such that active cells (all, except Cell 3 in T3) are fully allocated and a constant total transmitted power spectral density is achieved for all OFDM symbols other than those in the subframes with transmitted PRS. There is no PDSCH allocated in the subframes with transmitted PRS.</p> <p>Note 2: The resources for uplink transmission are assigned to the UE prior to the start of time period T2.</p> <p>Note 3: Interference from other cells and noise sources not specified in the test are assumed to be constant over subcarriers and time and shall be modelled as AWGN of appropriate power for <math>N_{oc}</math> to be fulfilled.</p> <p>Note 4: If PRS_RA is not "N/A", <math>PRS \hat{E}_s/I_{ot}</math>, <math>I_o</math>, RSRP and PRP levels have been derived from other parameters and are given for information purpose. If PRS_RA is "N/A", <math>I_o</math> and RSRP levels have been derived from other parameters and are given for information purpose. These are not settable test parameters. Interference conditions shall be applied to all PRS symbols of DL positioning subframes.</p>							

The response time including test tolerance is [3.3]s for Test 1 and [6.3]s for Test 2. The response time is equal to the LPP responseTime IE value plus the test tolerance. The LPP responseTime IE value is derived from the RSTD reporting delay plus  $\Delta T$ , where  $\Delta T = 150$  ms, giving a value of 2710 ms for Test 1 and 5110ms for Test 2. This is rounded up to the next allowed LPP value of 3 seconds for Test 1 and 6 seconds for Test 2.

The RSTD measurement reporting delay in the tests is derived from the following expression,

$T_{PRS} (M - 1) + 160 \left\lceil \frac{n}{M} \right\rceil$ , where  $M = 8$  and  $n = 16$  for Test 1, and  $M = 16$  and  $n = 16$  for Test 2 are the parameters specified in clause 10.1.3.1 for Test 1 and clause 10.1.3.2 for Test 2.

This gives the total RSTD reporting delay of 2560 ms for Test 1 for the 15 neighbour cells including Cell 3 with respect to the reference cell, Cell 2.

This gives the total RSTD reporting delay of 4960 ms for Test 2 for the 15 neighbour cells including Cell 1 and Cell 3 with respect to the reference cell, Cell 2.

The test tolerances are defined in clauses C.1.3 and C.4.

For the overall test to pass, the rate of successful tests during repeated tests in both Test 1 and Test 2 shall be more than 90% with a confidence level of 95%.

## 10.2 TDD RSTD Measurement Reporting Delay for Carrier Aggregation

**Editor's note: This test case is incomplete. The following aspects are either missing or not yet determined:**

- *The connection diagram is undefined.*
- *Further study and discussion with RAN 4 is needed to determine the meaning of "/or" in the test procedure and how to test the case where "the UE is expected to report RSTD measurements performed on PCC and/or on SCC".*
- *The Test system uncertainties applicable to this test are undefined.*
- *The Test tolerances applicable to this test are undefined.*

### 10.2.1 Test purpose

To verify that the RSTD measurement reporting delay meets the requirements in an environment with fading propagation conditions. This test case verifies the measurement period requirements for RSTD measurements performed on the secondary component carrier and also the measurement period requirements for RSTD measurements performed on both the primary and secondary component carriers.

### 10.2.2 Test applicability

This test applies to all types of E-UTRA TDD UE release 10 and forward that supports UE-assisted OTDOA for Carrier Aggregation.

### 10.2.3 Minimum conformance requirements

#### 10.2.3.1 Measurements on the secondary component carrier

The RSTD measurements when all cells are on the configured secondary component carrier shall meet all applicable requirements (TDD) specified in TS 36.133 [23] section 8.1.2.5, i.e., E-UTRAN intra-frequency RSTD measurement period applies, regardless of whether the SCell on the corresponding frequency is activated or deactivated by the MAC-CE commands as specified in 3GPP TS 36.321 [34].

#### 10.2.3.2 Measurements on both primary component carrier and secondary component carrier

The RSTD measurements of cells on both primary component carrier and configured secondary component carrier shall meet all applicable requirements (TDD) specified in TS 36.133 [23] section 8.1.2.6, i.e., E-UTRAN inter-frequency RSTD measurement period applies regardless of whether the SCell on the corresponding frequency is activated or deactivated by the MAC-CE commands as specified in 3GPP TS 36.321 [34], with the following exceptions

- the number of PRS positioning occasions is as specified in Table 10.2.3.2-1 shall apply, and
- TDD uplink-downlink subframes configurations as specified in TS 36.133 [23] section 8.1.2.5.2, Table 8.1.2.5.2-2 shall apply.

**Table 10.2.3.2-1: Number of PRS positioning occasions within measurement period**

Positioning subframe configuration period $T_{\text{PRS}}$	Number of PRS positioning occasions $M$
160 ms	32
>160 ms	16

The normative reference for this requirement is TS 36.133 [23] clause 8.4.3, 8.4.4 and A.8.17.2.

## 10.2.4 Test description

### 10.2.4.1 Initial conditions

Test Environment: Normal; as defined in TS 36.508 [18] clause 4.1.

Frequencies to be tested: Mid Range, as defined in TS 36.508 [18] clause 4.3.1.2.

Channel bandwidth to be tested: 10 MHz as defined in TS 36.508 [18] clause 4.3.1.

1. Connect the SS, faders and AWGN noise sources to the UE antenna connector or antenna connectors as shown in Annex A, Figure FFS.
2. The general test parameter settings are set up according to Table 10.2.4.1-1.
3. Propagation conditions are set according to clause 4.7.2.1.
4. Message contents are defined in clause 10.2.4.3.
5. In the tests, there are two configured component carriers: PCC and SCC, and three synchronized cells: Cell 1, Cell 2 and Cell 3. Cell 1 is PCell on the PCC, Cell 2 is an active SCell on the SCC, and Cell 3 is a neighbour cell on the SCC. In both tests, Cell 2 is the OTDOA assistance data reference cell. The assistance data neighbour cell list includes in total 15 cells, where 14 of the cells are not simulated (dummy cells; as defined in 3GPP TS 37.571-5 clause 7.3.2) for Test 1 and where 13 of the cells are not simulated for Test 2. PCell (Cell 1) is the cell used for connection setup with the power level and mapping set according to TS 36.521-1 [24] Annex C.0 and C.1 as appropriate for this test. Cell 2 and Cell 3 are powered OFF.
6. The true RSTD (which is the receive time difference for frame 0 between two cells as seen at the UE antenna connector) is set to 0 Ts (0  $\mu$ s) between neighbour Cell 3 and OTDOA assistance data reference cell, Cell 2; and set to 92 Ts (about 3  $\mu$ s) between neighbour Cell 1 and OTDOA assistance data reference cell, Cell 2.

**Table 10.2.4.1-1: General test parameters for E-UTRAN TDD RSTD measurement reporting delay under fading propagation conditions for Carrier Aggregation**

Parameter	Unit	Value		Comment
		Test 1	Test 2	
PCell		Cell 1		PCell is on RF channel 1 (PCC).
SCell		Cell 2		SCell on RF channel 2 (SCC). Cell 2 is the assistance data reference cell.
Other neighbour cell		Cell 3		Neighbour cell on RF channel 2 (SCC).
PCFICH/PDCCH/PHICH parameters		DL Reference Measurement Channel R.6 FDD		As specified in TS 36.521-3 [25] clause A.2.2
Channel Bandwidth (BW <sub>channel</sub> )	MHz	10		
PRS Transmission Bandwidth <sup>Note 2</sup>	RB	50		PRS are transmitted over the system bandwidth
PRS configuration index $I_{PRS}$ <sup>Note 2</sup>		174 for all cells on PCC 184 for all cells on SCC		This corresponds to periodicity of 320 ms and PRS subframe offset of $I_{PRS} - 160$ DL subframes, as defined in 3GPP TS 36.211 [26], Table 6.10.4.3-1
Number of consecutive downlink positioning subframes $N_{PRS}$ <sup>Note 2</sup>		1		As defined in 3GPP TS 36.211 [26]. The number of subframes in a positioning occasion
Physical cell ID PCI <sup>Note 2</sup>		$(\text{PCI of Cell 2} - \text{PCI of Cell 3}) \bmod 6 = 0$		The PCI of Cell 1 is selected randomly. PCIs of Cell 2 and Cell 3 are selected randomly such that the relative subcarrier shifts of PRS patterns among these cells are as given by the condition
TDD uplink-downlink configuration		1		As specified in TS 36.211 [26], Section 4.2; corresponds to a configuration with 5 ms switch-point periodicity and two downlink consecutive subframes
TDD special subframe configuration		6		As specified in TS 36.211 [26], Section 4.2; corresponds to DwPTS of $19760 \cdot T_s$ and UpPTS of $4384 \cdot T_s$
CP length <sup>Note 2</sup>		Normal		
DRX		ON		DRX parameters are further specified in Table 10.2.4.1-2
Maximum radio frame transmit time offset between the cells at the UE antenna connector <sup>Note 3</sup>	μs	3		Synchronous cells
Expected RSTD <sup>Note 1</sup>	μs	3		The expected RSTD is what is expected at the receiver. The corresponding parameter in the OTDOA assistance data specified in TS 36.355 [4] is the expectedRSTD indicator
Expected RSTD uncertainty <sup>Note 1</sup>	μs	5		The corresponding parameter in the OTDOA assistance data specified in TS 36.355 [4] is the expectedRSTD-Uncertainty index
Number of cells provided		16 cells in total		The list includes the reference

in OTDOA assistance data		OTDOA neighbour cells include Cell 3 and other 14 cells on SCC	OTDOA neighbour cells include Cell 1 and other 7 cells on PCC, and Cell 3 and other 6 cells on SCC	cell and 15 other cells. Cell 1 (when included) appears at random places in the first half of the neighbour cell list in the OTDOA assistance data. Cell 3 always appears at random places in the second half of the list
prs-SubframeOffset <sup>Note 3</sup>		Cells on PCC: 310 Cells on SCC, except reference cell: 0		Subframe offset, counted in full subframes. The corresponding parameter in the OTDOA assistance data is prs-SubframeOffset specified in TS 36.355 [4]
slotNumberOffset <sup>Note 3</sup>		Cells on PCC: 0 Cells on SCC, except reference cell: 0		The slot number offset at the transmitter between a neighbour cell and the assistance data reference cell. The corresponding parameter in the OTDOA assistance data is slotNumberOffset specified in TS 36.355 [4].
PRS muting info <sup>Note 2</sup>		Cell 1: '11110000' Cell 2: '00001111' Cell 3: '11110000'	Cell 1: '1111111100000000' Cell 2: '0000000011111111' Cell 3: '1111111100000000'	Corresponds to prs-MutingInfo defined in TS 36.355 [4]
T1	s	3		The length of the time interval from the beginning of each test
T2	s	1.28	2.48	The length of the time interval that follows immediately after time interval T1
T3	s	1.28	2.48	The length of the time interval that follows immediately after time interval T2
Note 1:	Parameters "Expected RSTD" and "Expected RSTD uncertainty" are not settable parameters. These are parameters signalled in LPP only. For the values to be used in LPP see Table 10.2.4.3-4 and TS 37.571-5 [20], clause 7.3.2.			
Note 2:	Parameters "PRS Transmission Bandwidth", "PRS configuration index", "Number of consecutive downlink positioning subframes", "Physical cell ID PCI", "CP length", "prs-SubframeOffset", "slotNumberOffset" and "PRS muting info" are settable parameters and also parameters signalled in LPP. The values to be used for "Physical cell ID PCI" are as follows: Cell 1: 0, Cell 2: 6, Cell 3: 12. For the values to be used in LPP see Table 10.2.4.3-4 and TS 37.571-5 [20], clause 7.3.2.			
Note 3:	The parameter "Maximum radio frame transmit time offset between the cells at the UE antenna connector" is not a settable parameter but is used to set the "true RSTD" values in step 6 of clause 10.2.4.1.			

**Table 10.2.4.1-2: DRX parameters for E-UTRAN TDD RSTD measurement reporting delay under fading propagation conditions for Carrier Aggregation**

Field	Value	Comment
onDurationTimer	psf1	As specified in 3GPP TS 36.331 [22], clause 6.3.2.
drx-InactivityTimer	psf1	
drx-RetransmissionTimer	sf1	
longDRX-CycleStartOffset	sf320	
shortDRX	disable	

### 10.2.4.2 Test procedure

The test case includes two tests. Test 1 is designed for the scenario where the UE receives OTDOA assistance data with cells on SCC, and the UE is expected to report RSTD measurements performed on SCC only. Test 2 is designed for the scenario where the UE receives OTDOA assistance data with cells on PCC and SCC, and the UE is expected to report RSTD measurements performed on PCC and/or on SCC.



Each test consists of three consecutive time intervals, with duration of T1, T2 and T3 defined in Table 10.2.4-1. Cell 1 is active in T1, T2 and T3, whilst Cell 2 and Cell 3 are activated only in the beginning of T2. Cell 2 is active until the end of T3, and Cell 3 is active until the end of T2. The beginning of the time interval T2 shall be aligned [5] ms before the first PRS positioning subframe of a positioning occasion in the reference cell, where [5] ms is the necessary test tolerance. Cell 1 transmits PRS in T2, while Cell 2 transmits PRS only in T3, and Cell 3 transmits PRS only in T2.

NOTE: The information on when PRS is muted is conveyed to the UE using PRS muting information in the OTDOA assistance data.

The OTDOA-RequestLocationInformation message and the OTDOA assistance data as defined in clause 10.2.4.3 shall be provided to the UE during T1. The last TTI containing the OTDOA-RequestLocationInformation message shall be provided to the UE  $\Delta T$  ms before the start of T2, where  $\Delta T = 150$  ms is the maximum processing time of the OTDOA-RequestLocationInformation message and the OTDOA assistance data.

1. Ensure that the UE is in state Generic RB Established State 3A-RF according to 3GPP TS 36.508 [18] clause 7.2A.3.
2. Configure Cell 2 and Cell 3 on the SCC according to TS 36.521-1 [24] Annex C.0 and C.1 for all downlink physical channels except PHICH.
3. The SS shall configure the SCell (Cell 2) on the SCC as per TS 36.508 [18] clause 5.2A.4.
4. The SS activates the SCell (Cell 2) by sending the Activation/Deactivation MAC control element according to TS 36.321 [34] clauses 5.13 and 6.1.3.8. Wait for at least 2 seconds as per TS 36.133 [23] clause 8.3.3.2.
5. The SS shall send a RESET UE POSITIONING STORED INFORMATION message.
6. Set the parameters according to Table 10.2.5-1. Propagation conditions are set according to clause 4.7.2.2 (ETU30).
7. T1 starts.
8. The SS shall transmit an RRCConnectionReconfiguration message with the DRX configuration.
9. The UE shall transmit RRCConnectionReconfigurationComplete message.
10. The SS shall send a LPP PROVIDE ASSISTANCE DATA message, including the *OTDOA-ProvideAssistanceData* IE. The position of neighbour Cell 3 in the *OTDOA-NeighbourCellInfoList* is randomly selected to be in the last 8 elements of the sequence for Test 1 and Test 2, and the position of neighbour Cell 1 is randomly selected to be in the first 7 elements of the sequence for Test 2, as described in 3GPP TS 37.571-5 [20], clause 7.3.2.
11. The SS shall send a LPP REQUEST LOCATION INFORMATION message, including the *OTDOA-RequestLocationInformation* IE such that the UE receives the message  $\Delta T$  ms before the start of T2, where  $\Delta T = 150$  ms.
12. When T1 expires, the SS shall switch the power setting from T1 to T2 as specified in Table 10.2.5-3.
13. When T2 expires, the SS shall switch the power setting from T2 to T3 as specified in Table 10.2.5-3.
14. The UE shall transmit a LPP PROVIDE LOCATION INFORMATION including the *OTDOA-ProvideLocationInformation* IE within the response time (see clause 4.7.3) specified in clause 10.2.5.

For Test 1 the UE shall perform and report the RSTD measurement for Cell 3 with respect to the reference cell in the OTDOA assistance data, Cell 2. If the UE transmits an *OTDOA-ProvideLocationInformation* IE including the *rstd* field for Cell 3 within the response time then the number of successful tests is increased by one. If the UE fails to report the *OTDOA-ProvideLocationInformation* IE with the *rstd* field included within the response time then the number of failure tests is increased by one.

For Test 2 the UE shall perform and report the RSTD measurements for both Cell 1 and Cell 3 with respect to the reference cell in the OTDOA assistance data, Cell 2. If the UE transmits an *OTDOA-ProvideLocationInformation* IE including the *rstd* field for both Cell 1 and Cell 3 within the response time then the number of successful tests is increased by one. If the UE fails to report the *OTDOA-ProvideLocationInformation* IE with both the *rstd* fields included within the response time then the number of failure tests is increased by one.

15. If the UE message at step 14 includes the *ackRequested* IE set to TRUE, the SS shall send a LPP acknowledgement message.
16. Repeat steps 5-15 until the confidence level according to Annex D is achieved. For each iteration, at step 10 change the random positions of the Cell 3 and Cell 1(for Test 2 only) in the *OTDOA-NeighbourCellInfoList*.
17. Repeat from clause 10.2.4.1 for Test 2.

### 10.2.4.3 Message contents

**Table 10.2.4.3-1: RESET UE POSITIONING STORED INFORMATION**

Derivation Path: 36.509 clause 6.9			
Information Element	Value/remark	Comment	Condition
UE Positioning Technology	0 0 0 0 0 0 1	OTDOA	

**Table 10.2.4.3-2: MAC-MainConfig-RBC: TDD RSTD Measurement Reporting Delay for Carrier Aggregation**

Derivation Path: TS 36.508 [18] clause 4.8.2.1.5, Table 4.8.2.1.5-1 MAC-MainConfig-RBC			
Information Element	Value/remark	Comment	Condition
MAC-MainConfig-RBC ::= SEQUENCE {			
drx-Config CHOICE {			
setup SEQUENCE {			
onDurationTimer	psf1		
drx-InactivityTimer	psf1		
drx-RetransmissionTimer	sf1		
longDRX-CycleStartOffset CHOICE {			
sf320	0		
}			
shortDRX	Not present		
}			
}			

Table 10.2.4.3-3: LPP RequestLocationInformation

Derivation Path: 36.355 clause 6.2			
Information Element	Value/remark	Comment	Condition
LPP-Message ::= SEQUENCE {			
transactionID SEQUENCE {			
Initiator	locationServer		
transactionNumber	1		
}			
endTransaction	FALSE		
sequenceNumber	Not present		
acknowledgement	Not present		
lpp-MessageBody CHOICE {			
c1 CHOICE {			
requestLocationInformation SEQUENCE {			
criticalExtensions CHOICE {			
c1 CHOICE {			
requestLocationInformation-r9 SEQUENCE {			
commonIEsRequestLocationInformation SEQUENCE {			
locationInformationType	locationMeasurementsRequired		
triggeredReporting	Not present		
periodicalReporting	Not present		
additionalInformation	onlyReturnInformationRequested		
qos SEQUENCE {			
horizontalAccuracy	Not present		
verticalCoordinateRequest	FALSE		
verticalAccuracy	Not present		
responseTime	Test 1: 3 Test 2: 6	See clause 10.2.5	
velocityRequest	FALSE		
}			
Environment	Not present		
locationCoordinateTypes	Not present		
velocityTypes	Not present		
}			
a-gnss-RequestLocationInformation	Not present		
otdoa-RequestLocationInformation SEQUENCE {			
assistanceAvailability	FALSE		
}			
ecid-RequestLocationInformation	Not present		
epdu-RequestLocationInformation	Not Present		
}			
}			
}			
}			
}			
}			



Table 10.2.4.3-5: LPP ProvideLocation Information

Derivation Path: 36.355 clause 6.2			
Information Element	Value/remark	Comment	Condition
LPP-Message ::= SEQUENCE {			
transactionID SEQUENCE {			
Initiator	locationServer		
transactionNumber	1		
}			
endTransaction	TRUE		
sequenceNumber	(0..255)		
acknowledgement			
lpp-MessageBody CHOICE {			
c1 CHOICE {			
provideLocationInformation SEQUENCE {			
criticalExtensions CHOICE {			
c1 CHOICE {			
provideLocationInformation-r9 SEQUENCE {			
commonIEsProvideLocationInformation	Not present.		
a-gnss-ProvideLocationInformation	Not present		
otdoa-ProvideLocationInformation			
SEQUENCE {			
otdoaSignalMeasurementInformation			
SEQUENCE {			
systemFrameNumber			
physCellIdRef	Cell 2		
cellGlobalIdRef			
earfcnRef			
referenceQuality			
neighbourMeasurementList			
SEQUENCE (SIZE(n)) {			
physCellIdNeighbour	Cell 3		
cellGlobalIdNeighbour			
earfcnNeighbour			
Rstd	Present		
rstd-Quality			
}			
neighbourMeasurementList			
SEQUENCE (SIZE(n)) {			
physCellIdNeighbour	Cell 1	Test 2 only	
cellGlobalIdNeighbour			
earfcnNeighbour			
Rstd	Present	Test 2 only	
rstd-Quality			
}			
}			
otdoa-Error	Maybe present with error reason 'undefined' or 'attemptedButUnableToMeasureSomeNeighbourCells'		
}			
ecid-ProvideLocationInformation	Not present		
epdu-ProvideLocationInformation	Not present		
}			
}			
}			
}			
}			
}			

## 10.2.5 Test requirement

Table 10.2.5-1 and 10.2.5-2 define the primary level settings including test tolerances for the test.

**Table 10.2.5-1: Cell-specific test parameters for E-UTRAN TDD RSTD measurement reporting delay under fading propagation conditions during T1 for Carrier Aggregation**

Parameter	Unit	Cell 1	Cell 2	Cell 3
E-UTRA RF Channel Number		1	N/A	N/A
OCNG patterns defined in TS 36.521-3 [25] clause D.1.2		OP.1 TDD	N/A	N/A
PBCH_RA	dB	0	N/A	N/A
PBCH_RB				
PSS_RA				
SSS_RA				
PCFICH_RB				
PHICH_RA				
PHICH_RB				
PDCCH_RA				
PDCCH_RB				
OCNG_RA <sup>Note 1</sup>				
OCNG_RB <sup>Note 1</sup>				
PRS_RA				
$N_{oc}$ <sup>Note 3</sup>	dBm/ 15 kHz	-95	N/A	N/A
$PRS \hat{E}_s / N_{oc}$	dB	-Infinity	-Infinity	-Infinity
$I_o$ <sup>Note 4</sup>	dBm/ 9 MHz	-64.21	N/A	N/A
$\hat{E}_s / N_{oc}$	dB	0	-Infinity	-Infinity
Propagation Condition		ETU30		
<p>Note 1: OCNG shall be used such that active cell (Cell 1) is fully allocated and a constant total transmitted power spectral density is achieved for all OFDM symbols.</p> <p>Note 2: The resources for uplink transmission are assigned to the UE prior to the start of time period T2.</p> <p>Note 3: Interference from other cells and noise sources not specified in the test are assumed to be constant over subcarriers and time and shall be modelled as AWGN of appropriate power for <math>N_{oc}</math> to be fulfilled.</p> <p>Note 4: <math>I_o</math> levels have been derived from other parameters and are given for information purpose. These are not settable test parameters.</p>				

**Table 10.2.5-2: Cell-specific test parameters for E-UTRAN TDD RSTD measurement reporting delay under fading propagation conditions during T2 and T3 for Carrier Aggregation**

Parameter	Unit	Cell 1		Cell 2		Cell 3	
		T2	T3	T2	T3	T2	T3
E-UTRAN Channel Number		1		2		2	
OCNG patterns defined in TS 36.521-3 [25] clause D.1.2		OP.1 TDD		OP.2 TDD		OP.2 TDD	N/A
PBCH_RA	dB	0		0		0	N/A
PBCH_RB							
PSS_RA							
SSS_RA							
PCFICH_RB							
PHICH_RA							
PHICH_RB							
PDCCH_RA							
PDCCH_RB							
OCNG_RA <sup>Note 1</sup>							
OCNG_RB <sup>Note 1</sup>							
PRS_RA	dB	[FFS]	N/A	N/A	0	0	N/A
$N_{oc}$ <sup>Note 3</sup>	dBm/15 kHz	-98	-98	-98	-95	-98	-95
$PRS \hat{E}_s / N_{oc}$	dB	-4 + TT	-Infinity	-Infinity	-10 + TT	-11 + TT	-Infinity
$PRS \hat{E}_s / I_{ot}$ <sup>Note 4</sup>	dB	-4 + TT	-Infinity	-Infinity	-10 + TT	-11 + TT	-Infinity
$I_o$ <sup>Note 4</sup>	dBm/9 MHz	-69.87	-[FFS]	-[FFS]	-67.15	-70.16	N/A
PRP <sup>Note 4</sup>	dBm/15 kHz	-102 + TT	-Infinity	-Infinity	-105 + TT	-109 + TT	-Infinity
RSRP <sup>Note 4</sup>	dBm/15 kHz	-[FFS] + TT	-[FFS] + TT	-105 + TT	-105 + TT	-109 + TT	-Infinity
$\hat{E}_s / N_{oc}$	dB	[FFS]	[FFS]	[FFS]	[FFS]	[FFS]	-Infinity
Propagation Condition		ETU30					
<p>Note 1: OCNG shall be used such that active cells (all, except Cell 3 in T3) are fully allocated and a constant total transmitted power spectral density is achieved for all OFDM symbols other than those in the subframes with transmitted PRS. There is no PDSCH allocated in the subframes with transmitted PRS.</p> <p>Note 2: The resources for uplink transmission are assigned to the UE prior to the start of time period T2.</p> <p>Note 3: Interference from other cells and noise sources not specified in the test are assumed to be constant over subcarriers and time and shall be modelled as AWGN of appropriate power for <math>N_{oc}</math> to be fulfilled.</p> <p>Note 4: If PRS_RA is not "N/A", <math>\hat{E}_s / N_{oc}</math>, <math>PRS \hat{E}_s / I_{ot}</math>, <math>I_o</math>, RSRP and PRP levels have been derived from other parameters and are given for information purpose. If PRS_RA is "N/A", <math>I_o</math> and RSRP levels have been derived from other parameters and are given for information purpose. These are not settable test parameters. Interference conditions shall be applied to all PRS symbols of DL positioning subframes.</p>							

The response time including test tolerance is [3.3]s for Test 1 and [6.3]s for Test 2. The response time is equal to the LPP responseTime IE value plus the test tolerance. The LPP responseTime IE value is derived from the RSTD reporting delay plus  $\Delta T$ , where  $\Delta T = 150$  ms, giving a value of 2710 ms for Test 1 and 5110ms for Test 2. This is rounded up to the next allowed LPP value of 3 seconds for Test 1 and 6 seconds for Test 2.

The RSTD measurement reporting delay in the tests is derived from the following expression,

$T_{PRS} (M - 1) + 160 \left\lceil \frac{n}{M} \right\rceil$ , where  $M = 8$  and  $n = 16$  for Test 1, and  $M = 16$  and  $n = 16$  for Test 2 are the parameters specified in clause 10.2.3.1 for Test 1 and clause 10.2.3.2 for Test 2.

This gives the total RSTD reporting delay of 2560 ms for Test 1 for the 15 neighbour cells including Cell 3 with respect to the reference cell, Cell 2.

This gives the total RSTD reporting delay of 4960 ms for Test 2 for the 15 neighbour cells including Cell 1 and Cell 3 with respect to the reference cell, Cell 2.

The test tolerances are defined in clauses C.1.3 and C.4.

For the overall test to pass, the rate of successful tests during repeated tests in both Test 1 and Test 2 shall be more than 90% with a confidence level of 95%.

## 10.3 FDD RSTD Measurement Accuracy for Carrier Aggregation

*Editor's note: This test case is incomplete. The following aspects are either missing or not yet determined:*

- *The connection diagram is undefined.*
- *The Test system uncertainties applicable to this test are undefined.*
- *The Test tolerances applicable to this test are undefined.*

### 10.3.1 Test purpose

To verify that the FDD RSTD measurement accuracy is within the specified limits when both the reference cell and neighbouring cell belong to the secondary component carrier.

### 10.3.2 Test applicability

This test applies to all types of E-UTRA FDD UE release 10 and forward that supports UE-assisted OTDOA for Carrier Aggregation.

### 10.3.3 Minimum conformance requirements

The UE may operate in either E-UTRA inter-band or intra-band carrier aggregation mode. The requirements in this section shall apply regardless whether the configured downlink secondary cell is activated or deactivated by the MAC-CE command (3GPP TS 36.321 [34]). The requirements apply for bandwidths defined in the bandwidth combination set for the CA configurations supported by the UE [2].

The RSTD measurements, which are obtained when both the reference cell and neighbouring cell belong to the secondary component carrier, shall meet the intra-frequency RSTD accuracy requirements defined in TS 36.133 [23] section 9.1.3.3.

The normative reference for this requirement is TS 36.133 [23] clause 9.1.12 and A.9.8.5.

### 10.3.4 Test description

#### 10.3.4.1 Initial conditions

Test Environment: Normal; as defined in TS 36.508 [18] clause 4.1.

Frequencies to be tested: Mid Range, as defined in TS 36.508 [18] clause 4.3.1.1.

Channel bandwidth to be tested: 10 MHz.

1. Connect the SS and AWGN noise sources to the UE antenna connector or antenna connectors as shown in Annex A, Figure FFS.



2. The general test parameter settings are set up according to Table 10.3.4.1-1.
3. Propagation conditions are set according to clause 4.7.2.1.
4. Message contents are defined in clause 10.3.4.3.
5. There are three synchronized cells on two different carrier frequencies. Cell 1 is the PCell on primary component carrier F1 (RF channel number 1), Cell 2 is the SCell and OTDOA assistance data reference cell on secondary component carrier F2 (RF channel number 2), and Cell 3 is the neighbour cell on F2. PCell (Cell 1) is the cell used for connection setup with the power level and mapping set according to TS 36.521-1 [24] Annex C.0 and C.1 as appropriate for this test. Cell 2 and Cell 3 are powered OFF.

Cell 3 is included in the OTDOA assistance data neighbour cell list, whilst Cell 1 is not included in the OTDOA assistance data. The assistance data neighbour cell list includes in total 15 cells, where 14 of the cells are not simulated (dummy cells; as defined in 3GPP TS 37.571-5 [20], clause 7.3.2).

Note that the measurement gap is not configured in the test because of UE carrier aggregation capability.

6. The true RSTD (which is the receive time difference for frame 0 between the two cells as seen at the UE antenna connector) is set to  $92 T_s$  ( $2.99 \mu s$ ) between neighbour Cell 3 and OTDOA assistance data reference cell, Cell 2.

Note that the related expectedRSTD value to be signalled over LPP is defined in Table 10.3.4.1-1.

Table 10.3.4.1-1: General Test Parameters for RSTD Test for E-UTRAN FDD for Carrier Aggregation

Parameter	Unit	Value	Comment
PCFICH/PDCCH/PHICH parameters		R.6 FDD	As specified in TS 36.521-3 [25] clause A.2.1
OCNG Patterns defined in TS 36.521-3 [25] clause D.1.1		OP.6 FDD	OCNG shall be used such that both cells are fully allocated and a constant total transmitted power spectral density is achieved for all OFDM symbols (other than those in the PRS subframes). There is no PDSCH allocated in the subframe transmitting PRS.
Assistance data reference cell		Cell 2	Cell 2 is the SCell on RF channel number 2
PCell		Cell 1	Cell 1 on RF channel number 1
Neighbour cell		Cell 3	Cell 3 on RF channel number 2
E-UTRA RF Channel Number		1,2	Two FDD carrier frequencies are used.
Channel Bandwidth ( $BW_{\text{channel}}$ )	MHz	10	
PRS Transmission Bandwidth <sup>Note 2</sup>	RB	50	PRS Bandwidth: bandwidth is as indicated in <i>prs-Bandwidth</i> in the OTDOA assistance data defined in 3GPP TS 36.355 [4].
PRS configuration Index $I_{\text{PRS}}$ <sup>Note 2</sup>		2	As defined in 3GPP TS 36.211 [26]
Number of consecutive positioning downlink subframes $N_{\text{PRS}}$ <sup>Note 2</sup>		1	As defined in 3GPP TS 36.211 [26]
prs-MutingInfo <sup>Note 2</sup>		Cell 1: '11110000' Cell 2: '11110000' Cell 3: '11110000'	See section 6.5.1.2 in 3GPP TS 36.355 [4] for more information
Cell ID <sup>Note 2</sup>		(Cell ID of cell 2 – Cell ID of cell 3) mod 6 = 3	PCI of cell 1 is selected randomly.
expectedRSTD <sup>Note 1</sup>	μs	3	The expected RSTD is what is expected at the receiver. The corresponding parameter in the OTDOA assistance data specified in TS 36.355 [4] is the expectedRSTD indicator
expectedRSTDUncertainty <sup>Note 1</sup>	μs	5	The corresponding parameter in the OTDOA assistance data specified in TS 36.355 [4] is the expectedRSTD-Uncertainty index
CP length <sup>Note 2</sup>		Normal	
DRX		OFF	
Radio frame transmit time difference between cells (cell 3 TX time – cell 2 TX time) <sup>Note 3</sup>	μs	3	Synchronous cells
Number of cells provided in OTDOA assistance data		16	The list includes the assistance-data-reference cell and 15 other cells. All cells provided in OTDOA assistance data are on RF channel 2.
$T_{\text{RSTD IntraFreqFDD, E-UTRAN}}$ <sup>Note 4</sup>	ms	2560	Derived according to the RSTD measurement requirements specified in Section 10.1.3
<p>NOTE 1: Parameters “Expected RSTD” and “Expected RSTD uncertainty” are not settable parameters. These are parameters signalled in LPP only. For the values to be used in LPP see Table 10.3.4.3-3 and TS 37.571-5 [20], clause 7.3.2.</p> <p>NOTE 2: Parameters “PRS Transmission Bandwidth”, “PRS configuration index”, “Number of consecutive positioning downlink subframes”, “prs-MutingInfo”, “Cell ID” and “CP length” are settable parameters and also parameters signalled in LPP. The values to be used for “Cell ID” are as follows: Cell 1: 0, Cell 2: 7, Cell 3: 10. For the values to be used in LPP see Table 10.3.4.3-3 and TS 37.571-5 [20], clause 7.3.2.</p> <p>NOTE 3: The parameter “Radio frame transmit time difference between cells (cell 3 TX time – cell 2 TX time)” is not a settable parameter but is used to set the “true RSTD” values in step 6 of clause 10.3.4.1.</p> <p>NOTE 4: The parameter “<math>T_{\text{RSTD IntraFreqFDD, E-UTRAN}}</math>” is not a settable parameter but is used to set the LPP “responseTime” value in Table 10.3.4.3-2. The value of the LPP responseTime IE is set to <math>T_{\text{RSTD IntraFreqFDD, E-UTRAN}} + \Delta T</math> ms, where <math>\Delta T = 150</math> ms, giving a value of 2710 ms. This is rounded up to the next allowed LPP value of 3 seconds.</p>			

### 10.3.4.2 Test procedure

The RSTD measurements are performed between Cell 2 and Cell 3 to verify that when both the reference cell and neighbouring cell belong to the secondary component carrier the RSTD measurement accuracy can meet the intra-frequency RSTD accuracy requirements defined in section 10.3.3.

The test consists of a set-up period and a measurement period. All cells are active during the complete test. The beginning of the measurement period shall be aligned with the first PRS positioning subframe of a positioning occasion in the reference cell.

NOTE: The information on when PRS is muted is conveyed to the UE using PRS muting information in the OTDOA assistance data.

The OTDOA-RequestLocationInformation message and the OTDOA assistance data as defined in clause 10.3.4.3 shall be provided to the UE during the set-up period. The last TTI containing the OTDOA-RequestLocationInformation message shall be provided to the UE  $\Delta T$  ms before the start of the measurement period, where  $\Delta T = 150$  ms is the maximum processing time of the OTDOA-RequestLocationInformation message and the OTDOA assistance data in the UE.

1. Ensure that the UE is in state Generic RB Established State 3A-RF according to 3GPP TS 36.508 [18] clause 7.2A.3.
2. Configure Cell 2 and Cell 3 on the SCC according to TS 36.521-1 [24] Annex C.0 and C.1 for all downlink physical channels except PHICH.
3. The SS shall configure the SCell (Cell 2) on the SCC as per TS 36.508 [18] clause 5.2A.4.
4. The SS activates the SCell (Cell 2) by sending the Activation/Deactivation MAC control element according to TS 36.321 [34] clauses 5.13 and 6.1.3.8. Wait for at least 2 seconds as per TS 36.133 [23] clause 8.3.3.2.
5. The SS shall send a RESET UE POSITIONING STORED INFORMATION message.
6. Set the parameters according to Table 10.3.5-1 as appropriate. Propagation conditions are set according to clause 4.7.2.1.
7. The SS shall send a LPP PROVIDE ASSISTANCE DATA message, including the *OTDOA-ProvideAssistanceData* IE.
8. The SS shall send a LPP REQUEST LOCATION INFORMATION message, including the *OTDOA-RequestLocationInformation* IE such that the UE receives the message  $\Delta T$  ms before the start of measurement period, where  $\Delta T = 150$  ms.
9. The UE shall transmit a LPP PROVIDE LOCATION INFORMATION message, including the *OTDOA-ProvideLocationInformation* IE.
10. If the UE message at step 9 includes the *ackRequested* IE set to TRUE, the SS shall send a LPP acknowledgement message.
11. The SS shall check the *rstd* value for Cell 3 in the *OTDOA-SignalMeasurementInformation* IE according to Table 10.3.5-2.
12. Repeat step 5-11 until the confidence level according to Annex D is achieved.

### 10.3.4.3 Message contents

**Table 10.3.4.3-1: RESET UE POSITIONING STORED INFORMATION**

Derivation Path: 36.509 clause 6.9			
Information Element	Value/remark	Comment	Condition
UE Positioning Technology	0 0 0 0 0 0 1	OTDOA	

Table 10.3.4.3-2: LPP RequestLocationInformation

Derivation Path: 36.355 clause 6.2			
Information Element	Value/remark	Comment	Condition
LPP-Message ::= SEQUENCE {			
transactionID SEQUENCE {			
Initiator	locationServer		
transactionNumber	1		
}			
endTransaction	FALSE		
sequenceNumber	Not present		
acknowledgement	Not present		
lpp-MessageBody CHOICE {			
c1 CHOICE {			
requestLocationInformation SEQUENCE {			
criticalExtensions CHOICE {			
c1 CHOICE {			
requestLocationInformation-r9 SEQUENCE {			
commonIEsRequestLocationInformation SEQUENCE {			
locationInformationType	locationMeasurementsRequired		
triggeredReporting	Not present		
periodicalReporting	Not present		
additionalInformation	onlyReturnInformationRequested		
qos SEQUENCE {			
horizontalAccuracy	Not present		
verticalCoordinateRequest	FALSE		
verticalAccuracy	Not present		
responseTime	3	See Note 5 of Table 10.3.4.1-1	
velocityRequest	FALSE		
}			
environment	Not present		
locationCoordinateTypes	Not present		
velocityTypes	Not present		
}			
a-gnss-RequestLocationInformation	Not present		
otdoa-RequestLocationInformation SEQUENCE {			
assistanceAvailability	FALSE		
}			
ecid-RequestLocationInformation	Not present		
epdu-RequestLocationInformation	Not Present		
}			
}			
}			
}			

Table 10.3.4.3-3: LPP ProvideAssistanceData

Derivation Path: 36.355 clause 6.2			
Information Element	Value/remark	Comment	Condition
LPP-Message ::= SEQUENCE {			
transactionID SEQUENCE {			
Initiator	locationServer		
transactionNumber	(0..255)		
}			
endTransaction	TRUE		
sequenceNumber	Not present		
acknowledgement	Not present		
lpp-MessageBody CHOICE {			
c1 CHOICE {			
provideAssistanceData SEQUENCE {			
criticalExtensions CHOICE {			
c1 CHOICE {			
provideAssistanceData-r9 SEQUENCE {			
commonIEs ProvideAssistanceData	Not present		
a-gnss-ProvideAssistanceData	Not present		
otdoa-ProvideAssistanceData SEQUENCE {			
otdoa-ReferenceCellInfo	As defined in TS 37.571-5 [20], clause 7.3.2.		
otdoa-NeighbourCellInfo	As defined in TS 37.571-5 [20], clause 7.3.2.		
otdoa-Error	Not present		
}			
epdu-ProvideAssistanceData	Not present		
}			
}			
}			
}			

Table 10.3.4.3-4: LPP ProvideLocation Information

Derivation Path: 36.355 clause 6.2			
Information Element	Value/remark	Comment	Condition
LPP-Message ::= SEQUENCE {			
transactionID SEQUENCE {			
Initiator	locationServer		
transactionNumber	1		
}			
endTransaction	TRUE		
sequenceNumber	(0..255)		
acknowledgement			
lpp-MessageBody CHOICE {			
c1 CHOICE {			
provideLocationInformation SEQUENCE {			
criticalExtensions CHOICE {			
c1 CHOICE {			
provideLocationInformation-r9 SEQUENCE {			
commonEsProvideLocationInformation	Not present.		
a-gnss-ProvideLocationInformation	Not present		
otdoa-ProvideLocationInformation			
SEQUENCE {			
otdoaSignalMeasurementInformation			
SEQUENCE {			
systemFrameNumber			
physCellIdRef	Cell 2		
cellGlobalIdRef			
earfcnRef			
referenceQuality			
neighbourMeasurementList			
SEQUENCE (SIZE(1)) {			
physCellIdNeighbour	Cell 3		
cellGlobalIdNeighbour			
earfcnNeighbour			
Rstd	Set according to Table 10.3.5-2		
rstd-Quality			
}			
}			
}			
otdoa-Error	May be present with error reason 'undefined' or 'attemptedButUnableToMeasureSomeNeighbourCells'		
}			
ecid-ProvideLocationInformation	Not present		
epdu-ProvideLocationInformation	Not present		
}			
}			
}			
}			

## 10.3.5 Test requirement

Table 10.3.5-1 defines the primary level settings including test tolerances for the test.

The FDD RSTD accuracy test shall meet the reported values in Table 10.3.5-2.

**Table 10.3.5-1: Cell Specific Test Parameters for RSTD Test for E-UTRAN FDD for Carrier Aggregation**

Parameter	Unit	Cell 1	Cell 2	Cell 3
E-UTRAN Channel Number		1	2	2
PBCH_RA				
PBCH_RB				
PSS_RA				
SSS_RA				
PCFICH_RB				
PHICH_RA				
PHICH_RB				
PDCCH_RA				
PDCCH_RB				
OCNG_RA <sup>Note 1</sup>				
OCNG_RB <sup>Note 1</sup>				
PRS_RA	dB	[FFS]	0	0
$N_{oc}$ <sup>Note 2</sup>	dBm/15 kHz	-98		
$\text{PRS } \hat{E}_s / N_{oc}$	dB	[FFS]	[FFS]	[FFS]
$\text{PRS } \hat{E}_s / I_{ot}$ <sup>Note 3</sup>	dB	-6 + TT	-6 + TT	-13 + TT
$I_o$ <sup>Note 3</sup>	dBm/9 MHz	-70.04	-70.01	-70.01
PRP <sup>Note 3</sup>	dBm/15kHz	-104 + TT	-104 + TT	-111 + TT
$\hat{E}_s / N_{oc}$ <sup>Note 3</sup>	dB	[FFS]	[FFS]	[FFS]
RSRP <sup>Note 3</sup>	dBm/15kHz	[FFS]	[FFS]	[FFS]
Propagation condition		AWGN		
<p>Note 1: OCNG shall be used such that both cells are fully allocated and a constant total transmitted power spectral density is achieved for all OFDM symbols (other than those in the PRS subframes). There is no PDSCH allocated in the subframe transmitting PRS.</p> <p>Note 2: Interference from other cells and noise sources not specified in the test is assumed to be constant over subcarriers and time and shall be modelled as AWGN of appropriate power for <math>N_{oc}</math> to be fulfilled.</p> <p>Note 3: <math>\hat{E}_s / N_{oc}</math>, <math>\text{PRS } \hat{E}_s / I_{ot}</math>, <math>I_o</math>, RSRP and PRP levels have been derived from other parameters for information purposes. They are not settable parameters themselves. <math>I_o</math> values are derived in the case that there is no PBCH, PSS or SSS in the OFDM symbols carrying PRS.</p>				

**Table 10.3.5-2: RSTD FDD accuracy requirements for the reported values for Carrier Aggregation**

	Value
Lowest reported value	RSTD_6432+TT
Highest reported value	RSTD_6462+TT

For the test to pass, the ratio of successful reported values shall be more than 90% with a confidence level of 95%.

## 10.4 TDD RSTD Measurement Accuracy for Carrier Aggregation

*Editor's note: This test case is incomplete. The following aspects are either missing or not yet determined:*

- The connection diagram is undefined.
- The Test system uncertainties applicable to this test are undefined.
- The Test tolerances applicable to this test are undefined.

### 10.4.1 Test purpose

To verify that the TDD RSTD measurement accuracy is within the specified limits when both the reference cell and neighbouring cell belong to the secondary component carrier.

## 10.4.2 Test applicability

This test applies to all types of E-UTRA TDD UE release 10 and forward that supports UE-assisted OTDOA for Carrier Aggregation.

## 10.4.3 Minimum conformance requirements

The UE may operate in either E-UTRA inter-band or intra-band carrier aggregation mode. The requirements in this section shall apply regardless whether the configured downlink secondary cell is activated or deactivated by the MAC-CE command (3GPP TS 36.321 [34]). The requirements apply for bandwidths defined in the bandwidth combination set for the CA configurations supported by the UE [2].

The RSTD measurements, which are obtained when both the reference cell and neighbouring cell belong to the secondary component carrier, shall meet the intra-frequency RSTD accuracy requirements defined in TS 36.133 [23] section 9.1.3.3.

The normative reference for this requirement is TS 36.133 [23] clause 9.1.12 and A.9.8.6.

## 10.4.4 Test description

### 10.4.4.1 Initial conditions

Test Environment: Normal; as defined in TS 36.508 [18] clause 4.1.

Frequencies to be tested: Mid Range, as defined in TS 36.508 [18] clause 4.3.1.2.

Channel bandwidth to be tested: 10 MHz.

1. Connect the SS and AWGN noise sources to the UE antenna connector or antenna connectors as shown in Annex A, Figure FFS.
2. The general test parameter settings are set up according to Table 10.4.4.1-1.
3. Propagation conditions are set according to clause 4.7.2.1.
4. Message contents are defined in clause 10.4.4.3.
5. There are three synchronized cells on two different carrier frequencies. Cell 1 is the PCell on primary component carrier F1 (RF channel number 1), Cell 2 is the SCell and OTDOA assistance data reference cell on secondary component carrier F2 (RF channel number 2), and Cell 3 is the neighbour cell on F2. PCell (Cell 1) is the cell used for connection setup with the power level and mapping set according to TS 36.521-1 [24] Annex C.0 and C.1 as appropriate for this test. Cell 2 and Cell 3 are powered OFF.

Cell 3 is included in the OTDOA assistance data neighbour cell list, whilst Cell 1 is not included in the OTDOA assistance data. The assistance data neighbour cell list includes in total 15 cells, where 14 of the cells are not simulated (dummy cells; as defined in 3GPP TS 37.571-5 [20], clause 7.3.2).

Note that the measurement gap is not configured in the test because of UE carrier aggregation capability.

6. The true RSTD (which is the receive time difference for frame 0 between the two cells as seen at the UE antenna connector) is set to 92 Ts (2.99  $\mu$ s) between neighbour Cell 3 and OTDOA assistance data reference cell, Cell 2.

Note that the related expected RSTD value to be signalled over LPP is defined in Table 10.4.4.1-1.



Table 10.4.4.1-1: General Test Parameters for RSTD Test for E-UTRAN TDD for Carrier Aggregation

Parameter	Unit	Value	Comment
PCFICH/PDCCH/PHICH parameters		R.6 TDD	As specified in TS 36.521-3 [25] clause A.2.1
OCNG Patterns defined in TS 36.521-3 [25] clause D.1.1		OP.2 TDD	OCNG shall be used such that both cells are fully allocated and a constant total transmitted power spectral density is achieved for all OFDM symbols (other than those in the PRS subframes). There is no PDSCH allocated in the subframe transmitting PRS.
Assistance data reference cell		Cell 2	Cell 2 is the SCell on RF channel number 2
PCell		Cell 1	Cell 1 on RF channel number 1
Neighbour cell		Cell 3	Cell 3 on RF channel number 2
E-UTRA RF Channel Number		1,2	Two TDD carrier frequencies are used.
Channel Bandwidth ( $BW_{\text{channel}}$ )	MHz	10	
Special subframe configuration		6	As specified in table 4.2-1 in TS 36.211 [26]. The same configuration in both cells.
Uplink-downlink configuration		1	As specified in table 4.2-2 in TS 36.211 [26] and table 8.1.2.5.2-2 in TS 36.133 [23]. The same configuration in both cells.
PRS Transmission Bandwidth <sup>Note 2</sup>	RB	50	PRS Bandwidth: bandwidth is as indicated in <i>prs-Bandwidth</i> in the OTDOA assistance data defined in 3GPP TS 36.355 [4].
PRS configuration Index $I_{\text{PRS}}$ <sup>Note 2</sup>		Cell 1: 5 Cell 2: 5 Cell 3: 5	As defined in 3GPP TS 36.211 [26]
Number of consecutive positioning downlink subframes $N_{\text{PRS}}$ <sup>Note 2</sup>		1	As defined in 3GPP TS 36.211 [26]
prs-MutingInfo <sup>Note 2</sup>		Cell 1: '11110000' Cell 2: '11110000' Cell 3: '11110000'	See section 6.5.1.2 in 3GPP TS 36.355 [4] for more information
Cell ID <sup>Note 2</sup>		(Cell ID of cell 2 – Cell ID of cell 3) mod 6 = 3	PCI of cell 1 is selected randomly.
expectedRSTD <sup>Note 1</sup>	$\mu\text{s}$	3	The expected RSTD is what is expected at the receiver. The corresponding parameter in the OTDOA assistance data specified in TS 36.355 [4] is the expectedRSTD indicator
expectedRSTDUncertainty <sup>Note 1</sup>	$\mu\text{s}$	5	The corresponding parameter in the OTDOA assistance data specified in TS 36.355 [4] is the expectedRSTD-Uncertainty index
CP length <sup>Note 2</sup>		Normal	
DRX		OFF	
Radio frame transmit time difference between cells (cell 3 TX time – cell 2 TX time) <sup>Note 3</sup>	$\mu\text{s}$	3	Synchronous cells
Number of cells provided in OTDOA assistance data		16	The list includes the assistance-data-reference cell and 15 other cells. All cells provided in OTDOA assistance data are on RF channel 2.
$T_{\text{RSTD IntraFreqFDD, E-UTRAN}}$ <sup>Note 4</sup>	ms	2560	Derived according to the RSTD measurement requirements specified in Section 10.2.3
<p>NOTE 1: Parameters "Expected RSTD" and "Expected RSTD uncertainty" are not settable parameters. These are parameters signalled in LPP only. For the values to be used in LPP see Table 10.4.4.3-3 and TS 37.571-5 [20], clause 7.3.2.</p> <p>NOTE 2: Parameters "PRS Transmission Bandwidth", "PRS configuration index", "Number of consecutive positioning downlink subframes", "prs-MutingInfo", "Cell ID" and "CP length" are settable parameters and also parameters signalled in LPP. The values to be used for "Cell ID" are as follows: Cell 1: 0, Cell 2: 7, Cell 3: 10. For the values to be used in LPP see Table 10.4.4.3-3 and TS 37.571-5 [20], clause 7.3.2.</p> <p>NOTE 3: The parameter "Radio frame transmit time difference between cells (cell 3 TX time – cell 2 TX time)" is not a settable parameter but is used to set the "true RSTD" values in step 6 of clause 10.4.4.1.</p> <p>NOTE 4: The parameter "<math>T_{\text{RSTD IntraFreqFDD, E-UTRAN}}</math>" is not a settable parameter but is used to set the LPP "responseTime" value in Table 10.4.4.3-2. The value of the LPP responseTime IE is set to <math>T_{\text{RSTD IntraFreqFDD, E-UTRAN}} + \Delta T</math> ms, where <math>\Delta T = 150</math> ms, giving a value of 2710 ms. This is rounded up to the next allowed LPP value of 3 seconds.</p>			

### 10.4.4.2 Test procedure

The RSTD measurements are performed between Cell 2 and Cell 3 to verify that when both the reference cell and neighbouring cell belong to the secondary component carrier the RSTD measurement accuracy can meet the intra-frequency RSTD accuracy requirements defined in section 10.4.3.

The test consists of a set-up period and a measurement period. All Cells are active during the complete test. The beginning of the measurement period shall be aligned with the first PRS positioning subframe of a positioning occasion in the reference cell.

NOTE: The information on when PRS is muted is conveyed to the UE using PRS muting information in the OTDOA assistance data.

The OTDOA-RequestLocationInformation message and the OTDOA assistance data as defined in clause 10.4.4.3 shall be provided to the UE during the set-up period. The last TTI containing the OTDOA-RequestLocationInformation message shall be provided to the UE  $\Delta T$  ms before the start of the measurement period, where  $\Delta T = 150$  ms is the maximum processing time of the OTDOA-RequestLocationInformation message and the OTDOA assistance data in the UE.

1. Ensure that the UE is in state Generic RB Established State 3A-RF according to 3GPP TS 36.508 [18] clause 7.2A.3.
2. Configure Cell 2 and Cell 3 on the SCC according to TS 36.521-1 [24] Annex C.0 and C.1 for all downlink physical channels except PHICH.
3. The SS shall configure the SCell (Cell 2) on the SCC as per TS 36.508 [18] clause 5.2A.
4. The SS activates the SCell (Cell 2) by sending the Activation/Deactivation MAC control element according to TS 36.321 [34] clauses 5.13 and 6.1.3.8. Wait for at least 2 seconds as per TS 36.133 [23] clause 8.3.3.2.
5. The SS shall send a RESET UE POSITIONING STORED INFORMATION message.
6. Set the parameters according to Table 10.4.5-1 as appropriate. Propagation conditions are set according to clause 4.7.2.1.
7. The SS shall send a LPP PROVIDE ASSISTANCE DATA message, including the *OTDOA-ProvideAssistanceData* IE.
8. The SS shall send a LPP REQUEST LOCATION INFORMATION message, including the *OTDOA-RequestLocationInformation* IE such that the UE receives the message  $\Delta T$  ms before the start of measurement period, where  $\Delta T = 150$  ms.
9. The UE shall transmit a LPP PROVIDE LOCATION INFORMATION message, including the *OTDOA-ProvideLocationInformation* IE.
10. If the UE message at step 9 includes the *ackRequested* IE set to TRUE, the SS shall send a LPP acknowledgement message.
11. The SS shall check the *rstd* value for Cell 3 in the *OTDOA-SignalMeasurementInformation* IE according to Table 10.4.5-2.
12. Repeat step 5-11 until the confidence level according to Annex D is achieved.

### 10.4.4.3 Message contents

**Table 10.4.4.3-1: RESET UE POSITIONING STORED INFORMATION**

Derivation Path: 36.509 clause 6.9			
Information Element	Value/remark	Comment	Condition
UE Positioning Technology	0 0 0 0 0 0 1	OTDOA	

Table 10.4.4.3-2: LPP RequestLocationInformation

Derivation Path: 36.355 clause 6.2			
Information Element	Value/remark	Comment	Condition
LPP-Message ::= SEQUENCE {			
transactionID SEQUENCE {			
Initiator	locationServer		
transactionNumber	1		
}			
endTransaction	FALSE		
sequenceNumber	Not present		
acknowledgement	Not present		
lpp-MessageBody CHOICE {			
c1 CHOICE {			
requestLocationInformation SEQUENCE {			
criticalExtensions CHOICE {			
c1 CHOICE {			
requestLocationInformation-r9 SEQUENCE {			
commonIEsRequestLocationInformation SEQUENCE {			
locationInformationType	locationMeasurementsRequired		
triggeredReporting	Not present		
periodicalReporting	Not present		
additionalInformation	onlyReturnInformationRequested		
qos SEQUENCE {			
horizontalAccuracy	Not present		
verticalCoordinateRequest	FALSE		
verticalAccuracy	Not present		
responseTime	3	See Note 5 of Table 10.4.4.1-1	
velocityRequest	FALSE		
}			
Environment	Not present		
locationCoordinateTypes	Not present		
velocityTypes	Not present		
}			
a-gnss-RequestLocationInformation	Not present		
otdoa-RequestLocationInformation SEQUENCE {			
assistanceAvailability	FALSE		
}			
ecid-RequestLocationInformation	Not present		
epdu-RequestLocationInformation	Not Present		
}			
}			
}			
}			
}			
}			
}			

Table 10.4.4.3-3: LPP ProvideAssistanceData

Derivation Path: 36.355 clause 6.2			
Information Element	Value/remark	Comment	Condition
LPP-Message ::= SEQUENCE {			
transactionID SEQUENCE {			
Initiator	locationServer		
transactionNumber	(0..255)		
}			
endTransaction	TRUE		
sequenceNumber	Not present		
acknowledgement	Not present		
lpp-MessageBody CHOICE {			
c1 CHOICE {			
provideAssistanceData SEQUENCE {			
criticalExtensions CHOICE {			
c1 CHOICE {			
provideAssistanceData-r9 SEQUENCE {			
commonIEsProvideAssistanceData	Not present		
a-gnss-ProvideAssistanceData	Not present		
otdoa-ProvideAssistanceData SEQUENCE {			
otdoa-ReferenceCellInfo	As defined in TS 37.571-5 [20], clause 7.3.2.		
otdoa-NeighbourCellInfo	As defined in TS 37.571-5 [20], clause 7.3.2.		
otdoa-Error	Not present		
}			
epdu-ProvideAssistanceData	Not present		
}			
}			
}			
}			
}			
}			



**Table 10.4.5-1: Cell Specific Test Parameters for RSTD Test for E-UTRAN TDD for Carrier Aggregation**

Parameter	Unit	Cell 1	Cell 2	Cell 3				
E-UTRAN Channel Number		1	2	2				
PBCH_RA								
PBCH_RB								
PSS_RA								
SSS_RA								
PCFICH_RB								
PHICH_RA	dB	0	0	0				
PHICH_RB								
PDCCH_RA								
PDCCH_RB								
OCNG_RA <sup>Note 1</sup>								
OCNG_RB <sup>Note 1</sup>								
PRS_RA					[FFS]	0	0	
$N_{oc}$ <sup>Note 2</sup>					dBm/15 kHz			-98
$\hat{E}_s/N_{oc}$					[FFS]	[FFS]	[FFS]	
$\hat{E}_s/I_{ot}$ <sup>Note 3</sup>					[FFS]	[FFS]	[FFS]	
$I_o$ <sup>Note 3</sup>	dBm/9 MHz	-70.04	-70.01	-70.01				
PRP <sup>Note 3</sup>	dBm/15kHz	-104 + TT	-104 + TT	-111 + TT				
$\hat{E}_s/N_{oc}$ <sup>Note 3</sup>	dB	[FFS]	[FFS]	[FFS]				
RSRP <sup>Note 3</sup>	dBm/15kHz	[FFS]	[FFS]	[FFS]				
Propagation condition		AWGN						
<p>Note 1: OCNG shall be used such that both cells are fully allocated and a constant total transmitted power spectral density is achieved for all OFDM symbols (other than those in the PRS subframes). There is no PDSCH allocated in the subframe transmitting PRS.</p> <p>Note 2: Interference from other cells and noise sources not specified in the test is assumed to be constant over subcarriers and time and shall be modelled as AWGN of appropriate power for <math>N_{oc}</math> to be fulfilled.</p> <p>Note 3: <math>\hat{E}_s/N_{oc}</math>, <math>\hat{E}_s/I_{ot}</math>, <math>I_o</math>, RSRP and PRP levels have been derived from other parameters for information purposes. They are not settable parameters themselves. <math>I_o</math> values are derived in the case that there is no PBCH, PSS or SSS in the OFDM symbols carrying PRS.</p>								

**Table 10.4.5-2: RSTD TDD accuracy requirements for the reported values for Carrier Aggregation**

	Value
Lowest reported value	RSTD_6432+TT
Highest reported value	RSTD_6462+TT

For the test to pass, the ratio of successful reported values shall be more than 90% with a confidence level of 95%.

## Annex A (informative): Connection Diagrams

### Definition of Terms

**GNSS:** In this clause the term GNSS also includes the case where the only satellite system used is GPS.

**System Simulator or SS:** A device or system, that is capable of generating simulated Node B and/or eNode B signalling and analysing UE signalling responses on one RF channel, in order to create the required test environment for the UE under test. It will also include the following capabilities:

1. Control of the UETx output power through TPC commands.

2. Measurement of signalling timing and delays.
3. Ability to simulate UTRAN and/or E-UTRAN signalling.

**GNSS System Simulator or GSS:** A device or system, that is capable of generating simulated GNSS satellite transmissions in order to create the required test environment for the UE under test. It will also include the following capabilities:

1. Control of the output power of individual satellites and the simulation of atmospheric delays and multi-path.
2. Generation of appropriate assistance data to be transmitted to the UE via the SS.
3. Ability to synchronize with UTRAN and/or E-UTRAN timing in the SS.

**Test System:** A combination of devices brought together into a system for the purpose of making one or more measurements on a UE in accordance with the test case requirements. The following diagrams are all examples of Test Systems.

NOTE: The above terms are logical definitions to be used to describe the test methods used in the present document, in practice, real devices called "System Simulators" may also include additional measurement capabilities or may only support those features required for the test cases they are designed to perform.

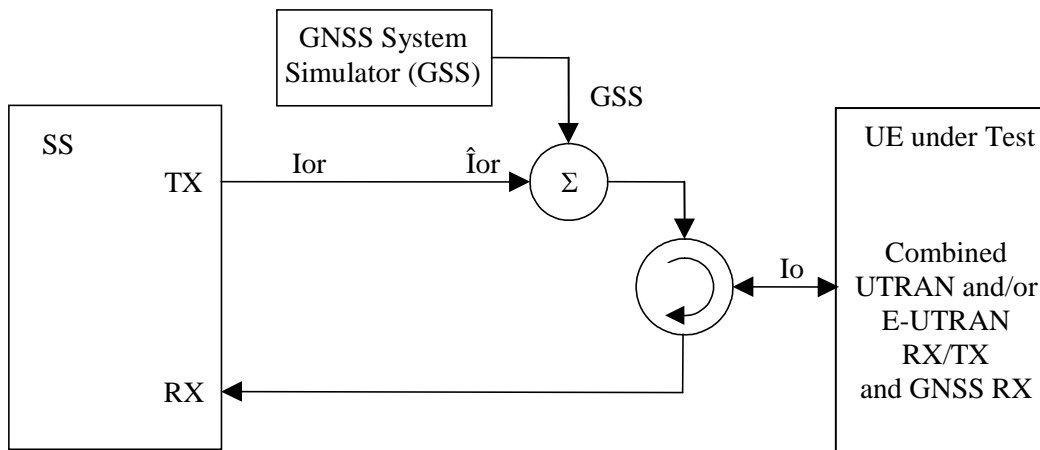

**Figure A.1: Connection for A-GNSS Minimum Performance requirements tests for UE with combined UTRAN and/or E-UTRAN / GNSS antenna**

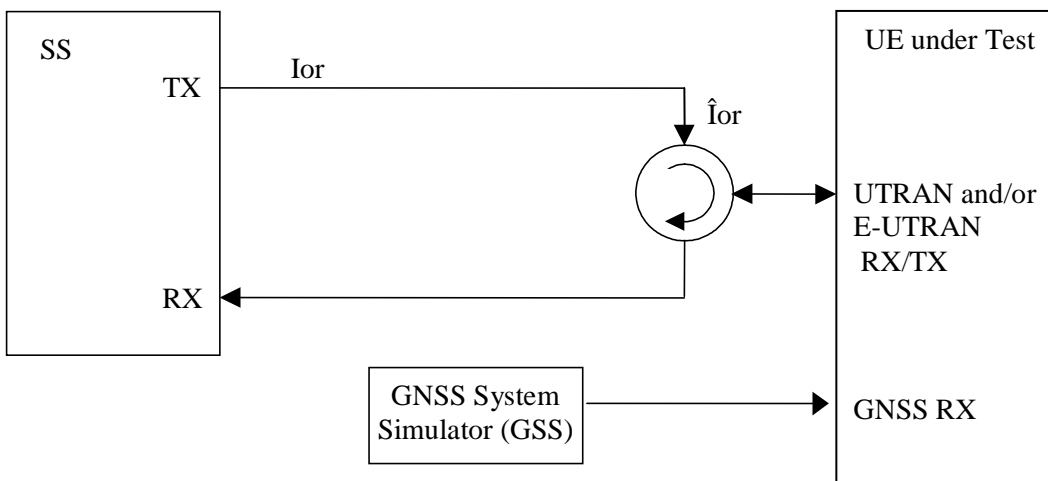

**Figure A.2: Connection for A-GNSS Minimum Performance requirements tests for UE with separate UTRAN and/or E-UTRAN and GNSS antennas**

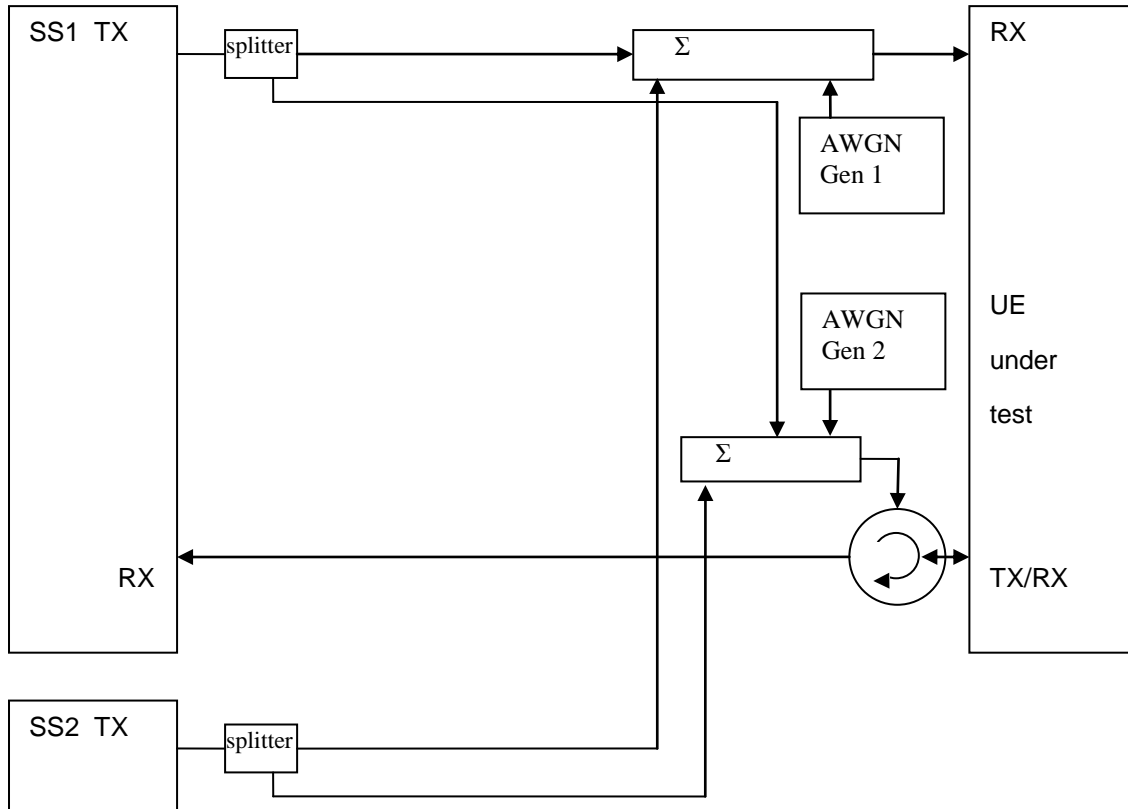

Figure A.3: Connection for 2 cells OTDOA tests with static propagation



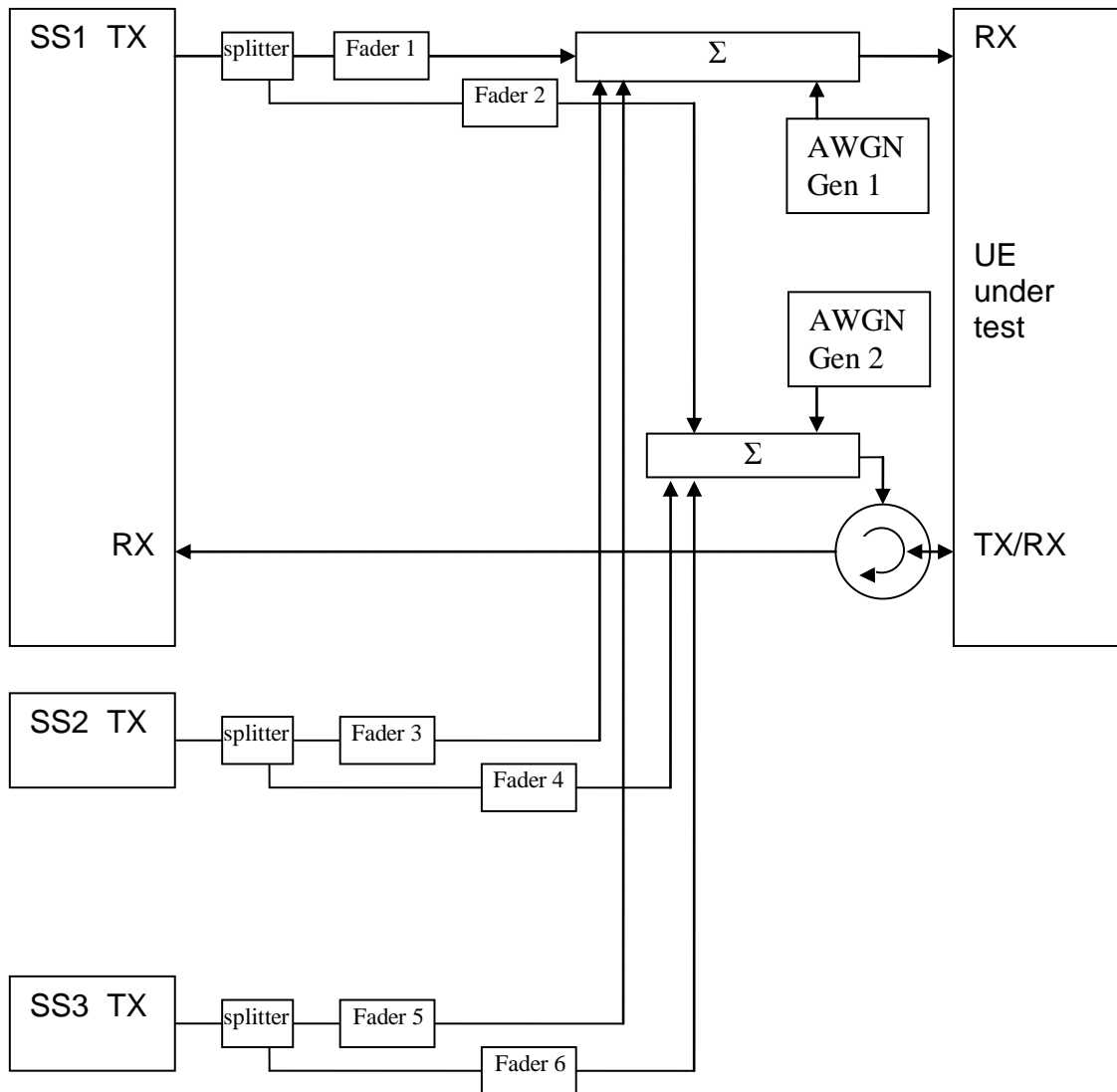

Figure A.4: Connection for 3 cells OTDOA tests with multipath fading propagation conditions

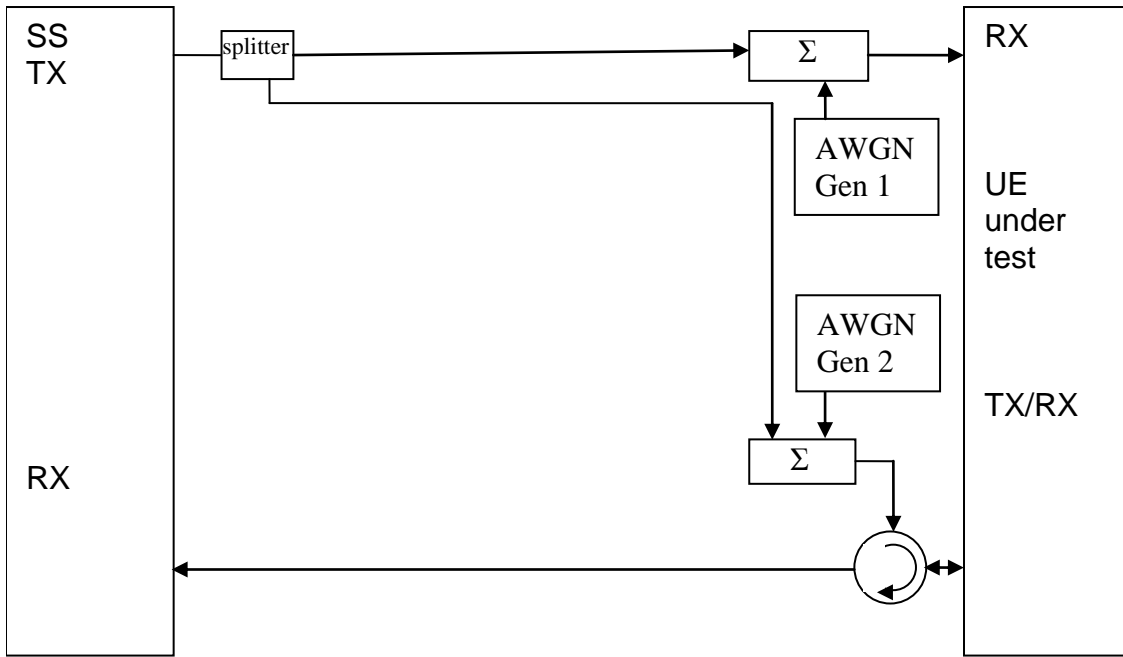

Figure A.5: Connection for 1 cell ECID tests with static propagation conditions

---

## Annex B (normative): Converting A-GNSS UE-assisted measurement reports into position estimates

### B.1 Introduction

In this clause the terms GNSS and A-GNSS also include the cases where the only satellite system used is GPS unless otherwise stated.

To convert the A-GNSS UE measurement reports in case of UE-assisted mode of A-GNSS into position errors, a transformation between the "measurement domain" (code-phases, etc.) into the "state" domain (position estimate) is necessary. Such a transformation procedure is outlined in the following clauses. The details can be found in [8-10] and [12-17].

### B.2 UTRAN UE measurement reports for A-GPS L1 C/A only

In case of UTRAN UE-assisted A-GPS L1 C/A only, the measurement parameters are contained in the RRC UE POSITIONING GPS MEASURED RESULTS IE (clause 10.3.7.93 in 3GPP TS 25.331 [30]). The measurement parameters required for calculating the UE position are:

- 1) Reference Time: The UE has two choices for the Reference Time:
  - a) "UE GPS timing of cell frames";
  - b) "GPS TOW msec".
- 2) Measurement Parameters: 1 to <maxSat>:
  - a) "Satellite ID (SV PRN)";
  - b) "Whole GPS chips";
  - c) "Fractional GPS Chips";
  - d) "Pseudorange RMS Error".

Additional information required at the system simulator:

- 1) "UE positioning GPS reference UE position" (clause 10.3.8.4c in 3GPP TS 25.331 [30]):  
Used for initial approximate receiver coordinates.
- 2) "UE positioning GPS navigation model" (clause 10.3.7.94 in 3GPP TS 25.331 [30]):  
Contains the GPS ephemeris and clock correction parameters as specified in [8]; used for calculating the satellite positions and clock corrections.
- 3) "UE positioning GPS ionospheric model" (clause 10.3.7.92 in 3GPP TS 25.331 [30]):  
Contains the ionospheric parameters which allow the single frequency user to utilize the ionospheric model as specified in [8] for computation of the ionospheric delay.

### B.3 UTRAN UE measurement reports for A-GNSS

In case of UTRAN UE-assisted A-GNSS, the measurement parameters are contained in the RRC UE POSITIONING GNSS MEASURED RESULTS IE (clause 10.3.7.93a in 3GPP TS 25.331 [30]). In case the UE provides also measurements on the GPS L1 C/A signal, the measurement parameters are contained in the RRC UE POSITIONING GPS MEASURED RESULTS IE (clause 10.3.7.93 in 3GPP TS 25.331 [30]). The measurement parameters required for calculating the UE position are:

- 1) Reference Time: The UE has two choices for the Reference Time:

- a) "UE GANSS Timing of Cell Frames" and/or "UE GPS Timing of Cell Frames";
- b) "GANSS TOD msec" and/or "GPS TOW msec" if GPS L1 C/A signal measurements are also provided.

NOTE: It is not expected that an UE will ever report both a GANSS TOD and a GPS TOW. However if two time stamps are provided and they derive from different user times, be aware that no compensation is made for this difference and this could affect the location accuracy.

- 2) Measurement Parameters for each GANSS and GANSS Signal: 1 to <maxGANSSSat>:
  - a) "Satellite ID"; mapping according to table 10.3.7.88b in 3GPP TS 25.331 [30];
  - b) "GANSS Code Phase";
  - c) "GANSS Integer Code Phase";
  - d) "GANSS Integer Code Phase Extension";
  - e) "Code Phase RMS Error";
- 3) Additional Measurement Parameters in case of GPS L1 C/A signal measurements are also provided: 1 to <maxSat>:
  - a) "Satellite ID (SV PRN)";
  - b) "Whole GPS chips";
  - c) "Fractional GPS Chips";
  - d) "Pseudorange RMS Error".

Additional information required at the system simulator:

- 1) "UE Positioning GANSS Reference UE Position" or "UE Positioning GPS Reference UE Position" (clause 10.3.8.4c in 3GPP TS 25.331 [30]):  
Used for initial approximate receiver coordinates.
- 2) "UE Positioning GANSS Navigation Model" and "UE Positioning GANSS Additional Navigation Models" (clauses 10.3.7.94a and 10.3.7.94b in 3GPP TS 25.331 [30]):  
Contains the ephemeris and clock correction parameters as specified in the relevant ICD of each supported GANSS; used for calculating the satellite positions and clock corrections.
- 3) "UE Positioning GANSS Ionospheric Model" (clause 10.3.7.92a in 3GPP TS 25.331 [30]):  
Contains the ionospheric parameters which allow the single frequency user to utilize the ionospheric model as specified in [21] for computation of the ionospheric delay.
- 4) "UE Positioning GANSS Additional Ionospheric Model" (clause 10.3.7.92b in 3GPP TS 25.331 [30]):  
Contains the ionospheric parameters which allow the single frequency user to utilize the ionospheric model as specified in [20] for computation of the ionospheric delay.
- 5) "UE Positioning GANSS Time Model" (clause 10.3.7.97a in 3GPP TS 25.331 [30]):  
Contains the GNSS-GNSS Time Offset for each supported GANSS. Note, that "UE Positioning GANSS Time Model" IE contains only the sub-ms part of the offset. Any potential integer seconds offset may be obtained from "UE Positioning GPS UTC Model" (clause 10.3.7.97 in 3GPP TS 25.331 [30]), "UE Positioning GANSS UTC Model" (clause 10.3.7.97c in 3GPP TS 25.331 [30]), or "UE Positioning GANSS Additional UTC Models" (clause 10.3.7.97d in 3GPP TS 25.331 [30]).
- 6) "UE Positioning GPS Navigation Model" (clause 10.3.7.94 in 3GPP TS 25.331 [30]):  
Contains the GPS ephemeris and clock correction parameters as specified in [8]; used for calculating the GPS satellite positions and clock corrections in case of GPS L1 C/A signal measurements are the only GPS measurements provided in addition to GANSS measurements.
- 7) "UE Positioning GPS Ionospheric Model" (clause 10.3.7.92 in 3GPP TS 25.331 [30]):  
Contains the ionospheric parameters which allow the single frequency user to utilize the ionospheric model as specified in [8] for computation of the ionospheric delay.

## B.4 E-UTRAN UE measurement reports

In case of E-UTRAN UE-assisted A-GNSS, the measurement parameters are contained in the LPP GNSS-SignalMeasurementInformation IE (clause 6.5.2.6 in 3GPP TS 36.355 [4]). The measurement parameters required for calculating the UE position are:

- 1) Reference Time: The UE has two choices for the Reference Time:
  - a) "networkTime";
  - b) "gnss-TOD-msec".
- 2) Measurement Parameters for each GNSS and GNSS signal: 1 to 64:
  - a) "svID";
  - b) "codePhase";
  - c) "integerCodePhase";
  - d) "codePhaseRMSError".

Additional information required at the system simulator:

- 1) "GNSS-ReferenceLocation" (clause 6.5.2.2 in 3GPP TS 36.355 [4]):  
Used for initial approximate receiver coordinates.
- 2) "GNSS-NavigationModel" (clause 6.5.2.2 in 3GPP TS 36.355 [4]):  
Contains the GNSS ephemeris and clock correction parameters as specified in the relevant ICD of each supported GNSS; used for calculating the satellite positions and clock corrections.
- 3) "GNSS-IonosphericModel" (clause 6.5.2.2 in 3GPP TS 36.355 [4]):  
Contains the ionospheric parameters which allow the single frequency user to utilize the ionospheric model as specified in the relevant ICD of each supported GNSS for computation of the ionospheric delay.

## B.5 WLS position solution

The WLS position solution problem is concerned with the task of solving for four unknowns;  $x_u, y_u, z_u$  the receiver coordinates in a suitable frame of reference (usually ECEF) and  $b_u$  the receiver clock bias. It typically requires the following steps:

### Step 1: Formation of pseudo-ranges

The observation of code phase reported by the UE for each satellite SV<sub>*i*</sub> is related to the pseudo-range/*c* modulo the "GNSS Code Phase Ambiguity" (UTRAN), or "gnss-CodePhaseAmbiguity" (E-UTRAN), or modulo 1 ms (the length of the C/A code period) in case of GPS L1 C/A signal measurements. For the formation of pseudo-ranges, the integer number of milliseconds to be added to each code-phase measurement has to be determined first. Since 1 ms corresponds to a travelled distance of 300 km, the number of integer ms can be found with the help of reference location and satellite ephemeris. The distance between the reference location and each satellite SV<sub>*i*</sub> is calculated and the integer number of milliseconds to be added to the UE code phase measurements is obtained.

### Step 2: Correction of pseudo-ranges for the GNSS-GNSS time offsets

In the case that the UE reports measurements for more than a single GNSS, the pseudo-ranges are corrected for the time offsets between the GNSSs relative to the selected reference time using the GNSS-GNSS time offsets available at the system simulator:

$$\rho_{GNSS_m,i} \equiv \rho_{GNSS_m,i} - c \cdot (t_{GNSS_k} - t_{GNSS_m}),$$

where  $\rho_{GNSS_m,i}$  is the measured pseudo-range of satellite *i* of GNSS<sub>*m*</sub>. The system time  $t_{GNSS_k}$  of GNSS<sub>*k*</sub> is the reference time frame, and  $(t_{GNSS_k} - t_{GNSS_m})$  is the available GNSS-GNSS time offset, and *c* is the speed of light.

### Step 3: Formation of weighting matrix

The UE reported "codePhaseRMSError" (E-UTRAN) or "Code Phase RMS Error" and/or "Pseudorange RMS Error" (UTRAN) values are used to calculate the weighting matrix for the WLS algorithm [9]. According to 3GPP TS 25.331 [30] and 3GPP TS 36.355 [4], the encoding for this field is a 6 bit value that consists of a 3 bit mantissa,  $X_i$  and a 3 bit exponent,  $Y_i$  for each SV<sub>*i*</sub>:

$$w_i = RMSError = 0.5 \times \left( 1 + \frac{X_i}{8} \right) \times 2^{Y_i}$$

The weighting Matrix  $\mathbf{W}$  is defined as a diagonal matrix containing the estimated variances calculated from the "codePhaseRMSError" (E-UTRAN) or "Code Phase RMS Error" and/or "Pseudorange RMS Error" (UTRAN) values:

$$\mathbf{W} = \text{diag} \left\{ 1/w_{GNSS_1,1}^2, 1/w_{GNSS_1,2}^2, \dots, 1/w_{GNSS_1,n}^2, \dots, 1/w_{GNSS_m,1}^2, 1/w_{GNSS_m,2}^2, \dots, 1/w_{GNSS_m,l}^2 \right\}$$

### Step 4: WLS position solution

The WLS position solution is described in reference [9] and usually requires the following steps:

- 1) Computation of satellite locations at time of transmission using the ephemeris parameters and user algorithms defined in the relevant ICD of the particular GNSS. The satellite locations are transformed into WGS -84 reference frame, if needed.
- 2) Computation of clock correction parameters using the parameters and algorithms as defined in the relevant ICD of the particular GNSS.
- 3) Computation of atmospheric delay corrections using the parameters and algorithms defined in the relevant ICD of the particular GNSS for the ionospheric delay, and using the Gupta model in reference [10] p. 121 equation (2) for the tropospheric delay. For GNSSs which do not natively provide ionospheric correction models (e.g., GLONASS), the ionospheric delay is determined using the available ionospheric model adapted to the particular GNSS frequency.
- 4) The WLS position solution starts with an initial estimate of the user state (position and clock offset). The Reference Location is used as initial position estimate. The following steps are required:
  - a) Calculate geometric range (corrected for Earth rotation) between initial location estimate and each satellite included in the UE measurement report.
  - b) Predict pseudo-ranges for each measurement including clock and atmospheric biases as calculated in 1) to 3) above and defined in the relevant ICD of the particular GNSS and [9].
  - c) Calculate difference between predicted and measured pseudo-ranges  $\Delta p$
  - d) Calculate the "Geometry Matrix"  $\mathbf{G}$  as defined in [9]:

$$\mathbf{G} \equiv \begin{bmatrix} -\hat{\mathbf{1}}_{GNSS_1,1}^T & 1 \\ -\hat{\mathbf{1}}_{GNSS_1,2}^T & 1 \\ \vdots & \vdots \\ -\hat{\mathbf{1}}_{GNSS_1,n}^T & 1 \\ \vdots & \vdots \\ -\hat{\mathbf{1}}_{GNSS_m,1}^T & 1 \\ -\hat{\mathbf{1}}_{GNSS_m,2}^T & 1 \\ \vdots & \vdots \\ -\hat{\mathbf{1}}_{GNSS_m,l}^T & 1 \end{bmatrix} \quad \text{with } \hat{\mathbf{1}}_{GNSS_m,i} \equiv \frac{\mathbf{r}_{GNSS_m,i} - \hat{\mathbf{r}}_u}{\left| \mathbf{r}_{GNSS_m,i} - \hat{\mathbf{r}}_u \right|} \quad \text{where } \mathbf{r}_{GNSS_m,i} \text{ is the satellite position vector for SV}_i \text{ of GNSS}_m$$

(calculated in 1) above), and  $\hat{\mathbf{r}}_u$  is the estimate of the user location.

- e) Calculate the WLS solution according to [9]:

$$\Delta\hat{\mathbf{x}} = (\mathbf{G}^T \mathbf{W} \mathbf{G})^{-1} \mathbf{G}^T \mathbf{W} \Delta\mathbf{p}$$

f) Adding the  $\Delta\hat{\mathbf{x}}$  to the initial state estimate gives an improved estimate of the state vector:

$$\hat{\mathbf{x}} \rightarrow \hat{\mathbf{x}} + \Delta\hat{\mathbf{x}}.$$

5) This new state vector  $\hat{\mathbf{x}}$  can be used as new initial estimate and the procedure is repeated until the change in  $\hat{\mathbf{x}}$  is sufficiently small.

#### **Step 5: Transformation from Cartesian coordinate system to Geodetic coordinate system**

The state vector  $\hat{\mathbf{x}}$  calculated in Step 4 contains the UE position in ECEF Cartesian coordinates together with the UE receiver clock bias relative to the selected GNSS system time. Only the user position is of further interest. It is usually desirable to convert from ECEF coordinates  $x_u, y_u, z_u$  to geodetic latitude  $\varphi$ , longitude  $\lambda$  and altitude  $h$  on the WGS84 reference ellipsoid.

#### **Step 6: Calculation of "2-D Position Errors"**

The latitude  $\varphi$  / longitude  $\lambda$  obtained after Step 5 is used to calculate the 2-D position error.

## Annex C (normative): General test conditions and declarations

The requirements of this clause apply to all applicable tests in the present document.

In all the relevant clauses in this clause all 2D position error measurements shall be carried out according to the general rules for statistical testing in Annex D.

In this clause the terms GNSS and A-GNSS also include the cases where the only satellite system used is GPS unless otherwise stated.

For operating bands 22, 42 and 43, the Test Tolerances may not be valid since some Test System uncertainties are changed for frequencies above 3000MHz. The Test Tolerances for those specific bands are therefore For Further Study [FFS].

### C.1 Acceptable uncertainty of Test System

The maximum acceptable uncertainty of the Test System is specified below for each test, where appropriate. The Test System shall enable the stimulus signals in the test case to be adjusted to within the specified range, and the equipment under test to be measured with an uncertainty not exceeding the specified values. All ranges and uncertainties are absolute values, and are valid for a confidence level of 95 %, unless otherwise stated.

A confidence level of 95 % is the measurement uncertainty tolerance interval for a specific measurement that contains 95 % of the performance of a population of test equipment.

It should be noted that the uncertainties in clause C.1 apply to the Test System operating into a nominal 50 ohm load and do not include system effects due to mismatch between the DUT and the Test System.

#### C.1.1 Measurement of test environments

The measurement accuracy of the UE environmental test conditions, defined in Annex G or TS 36.508 [18] clause 4.1, shall be:

Pressure	±5 kPa
Temperature	±2 degrees
Relative Humidity	±5 %
DC Voltage	±1.0 %
AC Voltage	±1.5 %
Vibration	10 %
Vibration frequency	0.1 Hz

The above values shall apply unless the test environment is otherwise controlled and the specification for the control of the test environment specifies the uncertainty for the parameter.



## C.1.2 A-GNSS Minimum Performance requirements

**Table C.1.1: Maximum Test System Uncertainty for A-GNSS Minimum Performance tests**

Clause	Maximum Test System Uncertainty	Derivation of Test System Uncertainty	
5.2.1, 6.2.1, 7.1.1 Sensitivity Coarse Time Assistance	Coarse Time Assistance	±200 ms	
	Absolute GNSS signal level	±1 dB	
	Position error	±0.05 m	Position error consists of ±0.05 m system uncertainty. The effect of position reporting resolution of approximately ±1.2 m (see note) is not included in the allowable test system uncertainty but is included in the Test Parameter Relaxations since this resolution limitation limits the reporting capability of the UE. For simplicity the combined Test Parameter Relaxation is given as ±1.3 m
	Response time	± 300 ms	
5.2.2, 6.2.2, 7.1.2 Sensitivity Fine Time Assistance	Coarse Time Assistance	±200 ms	
	Fine Time Assistance	±1 us	
	Absolute GNSS signal level	±1 dB	
	Position error	±0.05 m	Position error as above
	Response time	± 300 ms	
5.3, 6.3, 7.2 Nominal Accuracy	Coarse Time Assistance	±200 ms	
	Absolute GNSS signal level	±1 dB	
	Position error	±0.05 m	Position error as above
	Response time	± 300 ms	
5.4, 6.4, 7.3 Dynamic Range	Coarse Time Assistance	±200 ms	
	Absolute GNSS signal level	±1 dB	
	Relative GNSS signal level	±0.2 dB	
	Position error	±0.05 m	Position error as above
	Response time	± 300 ms	
5.5, 6.5, 7.4 Multi-path scenario	Coarse Time Assistance	±200 ms	
	Absolute GNSS signal level	±1 dB	
	Relative GNSS signal level	±0.2 dB	
	Position error	±0.05 m	Position error as above
	Response time	± 300 ms	
5.6, 6.6, 7.5 Moving scenario and periodic update	Absolute GNSS signal level ±1 dB	±1 dB	
	Position error ±0.05 m	±0.05 m	Position error as above
	Differential response time	± 100 ms	

NOTE: For UE based mode the effect of position reporting resolution is given by:

$$\sqrt{\left(\frac{90 \times 2 \times \pi \times R}{2E23 \times 360}\right)^2 + \left(\frac{360 \times 2 \times \pi \times R \times \cos \phi}{2E24 \times 360}\right)^2} \text{ meters, where } R \text{ is the radius of the earth and } \phi \text{ is the latitude of}$$

the location. For the GNSS scenarios defined in TS 37.571-5 [20] this equates to approximately Editor's note: this needs checking once the GNSS scenarios are agreed [TBD] m. For simplicity this is given as ±1.2 m.

For UE assisted mode it is assumed that the output from the WLS position solution calculation in Annex B is coded using the same position coding method as for UE based mode before being used to calculate position error. Therefore the effect of reporting resolution will be the same as for UE based mode.

### C.1.3 ECID and OTDOA Measurement requirements

**Table C.1.3-1: Maximum Test System Uncertainty for ECID and OTDOA Measurement Requirements**

Clause	Maximum Test System Uncertainty	Derivation of Test System Uncertainty
8.1.1 E-UTRAN FDD UE Rx – Tx time difference case	$N_{oc} \pm 1.0$ dB averaged over $BW_{Config}$ $\hat{E}_s / N_{oc} \pm 0.3$ dB  $\pm 3T_s$ Uplink signal transmit timing relative to downlink	Note: $\hat{E}_s / N_{oc}$ is the ratio of cell 1 signal / AWGN  $T_s = 1/(15000 \times 2048)$ seconds, the basic timing unit defined in TS 36.211 [26]
8.1.2 E-UTRAN TDD UE Rx – Tx time difference case	Same as 8.1.1	Same as 8.1.1
9.1.1 FDD RSTD Measurement Reporting Delay	$N_{oc} \pm 1.0$ dB averaged over $BW_{Config}$ PRS $\hat{E}_{s1} / N_{oc} \pm 0.6$ dB averaged over $BW_{Config}$ $\hat{E}_{s1} / N_{oc} \pm 0.6$ dB averaged over $BW_{Config}$ PRS $\hat{E}_{s2} / N_{oc} \pm 0.6$ dB averaged over $BW_{Config}$ $\hat{E}_{s2} / N_{oc} \pm 0.6$ dB averaged over $BW_{Config}$ PRS $\hat{E}_{s3} / N_{oc} \pm 0.6$ dB averaged over $BW_{Config}$ $\hat{E}_{s3} / N_{oc} \pm 0.6$ dB averaged over $BW_{Config}$ Response Time = $\pm 300$ ms	Note: PRS $\hat{E}_{s1} / N_{oc}$ and $\hat{E}_{s1} / N_{oc}$ are the ratios of cell 1 signal / AWGN PRS $\hat{E}_{s2} / N_{oc}$ and $\hat{E}_{s2} / N_{oc}$ are the ratios of cell 2 signal / AWGN PRS $\hat{E}_{s3} / N_{oc}$ and $\hat{E}_{s3} / N_{oc}$ are the ratios of cell 3 signal / AWGN  PRS $\hat{E}_s / N_{oc}$ and $\hat{E}_s / N_{oc}$ uncertainty for fading condition comprises two quantities: 1. Signal-to-noise ratio uncertainty 2. Fading profile power uncertainty  Items 1 and 2 are assumed to be uncorrelated so can be root sum squared: PRS $\hat{E}_s / N_{oc}$ and $\hat{E}_s / N_{oc}$ uncertainty = $\text{SQRT}(\text{Signal-to-noise ratio uncertainty}^2 + \text{Fading profile power uncertainty}^2)$ Signal-to-noise ratio uncertainty $\pm 0.3$ dB Fading profile power uncertainty $\pm 0.5$ dB
9.1.2 TDD RSTD Measurement Reporting Delay	Same as 9.1.1	
9.1.3 FDD RSTD Measurement Accuracy	$N_{oc} \pm 1.0$ dB averaged over $BW_{Config}$ PRS $\hat{E}_{s1} / N_{oc} \pm 0.3$ dB averaged over $BW_{Config}$ $\hat{E}_{s1} / N_{oc} \pm 0.3$ dB averaged over $BW_{Config}$ PRS $\hat{E}_{s2} / N_{oc} \pm 0.3$ dB averaged over $BW_{Config}$ $\hat{E}_{s2} / N_{oc} \pm 0.3$ dB averaged over $BW_{Config}$ Cell Timing Difference = $\pm 1 T_s$	Note: PRS $\hat{E}_{s1} / N_{oc}$ and $\hat{E}_{s1} / N_{oc}$ are the ratios of cell 1 signal / AWGN PRS $\hat{E}_{s2} / N_{oc}$ and $\hat{E}_{s2} / N_{oc}$ are the ratios of cell 2 signal / AWGN
9.1.4 TDD RSTD Measurement Accuracy	Same as 9.1.3	
9.2.1 FDD-FDD inter-frequency RSTD measurement reporting delay		
9.2.2 TDD-TDD inter-frequency RSTD measurement reporting delay		
9.2.4 FDD-FDD inter frequency RSTD Accuracy		
9.2.5 TDD-TDD inter frequency RSTD Accuracy		
10.1 FDD RSTD Measurement Reporting Delay for Carrier Aggregation		

10.2 TDD RSTD Measurement Reporting Delay for Carrier Aggregation		
10.3 FDD RSTD Measurement Accuracy for Carrier Aggregation		
10.4 TDD RSTD Measurement Accuracy for Carrier Aggregation		
In addition, the following Test System uncertainties and related constraints apply. Any additional constraints are defined in the specific tests.		
AWGN Bandwidth		$\geq 1.08\text{MHz}$ , $2.7\text{MHz}$ , $4.5\text{MHz}$ , $9\text{MHz}$ , $13.5\text{MHz}$ , $18\text{MHz}$ ; $N_{\text{RB}} \times 180\text{kHz}$ according to $BW_{\text{Config}}$
AWGN absolute power uncertainty		Test-specific
AWGN flatness and signal flatness, max deviation for any Resource Block, relative to average over $BW_{\text{Config}}$		$\pm 2\text{ dB}$
AWGN peak to average ratio		$\geq 10\text{ dB}$ @0.001%
Signal-to noise ratio uncertainty		Test-specific
Fading profile power uncertainty		$\pm 0.5\text{ dB}$
Fading profile delay uncertainty, relative to frame timing		$\pm 5\text{ ns}$ (excludes absolute errors related to baseband timing)

## C.2 Test Parameter Relaxations (This clause is informative)

The Test Parameter Relaxations defined in this clause have been used to relax the Conformance requirement to derive the Test Requirements.

The Test Parameter Relaxations are derived from Test System uncertainties, regulatory requirements and criticality to system performance. As a result, the Test Parameter Relaxations may sometimes be set to zero.

The Test Parameter Relaxations should not be modified for any reason e.g. to take account of commonly known test system errors (such as mismatch, cable loss, etc.).

## C.2.1 A-GNSS Minimum Performance requirements

**Table C.2.1: Test Parameter Relaxations for A-GNSS Minimum Performance tests**

Clause	Test Parameter Relaxation	
5.2.1, 6.2.1, 7.1.1 Sensitivity Coarse Time Assistance	Coarse Time Assistance	200 ms
	Absolute GNSS signal level	1 dB
	Position error	1.3 m
	Response time	300 ms
5.2.2, 6.2.2, 7.1.2 Sensitivity Fine Time Assistance	Coarse Time Assistance	200 ms
	Fine Time Assistance	1 us
	Absolute GNSS signal level	1 dB
	Position error	1.3 m
	Response time	300 ms
5.3, 6.3, 7.2 Nominal Accuracy	Coarse Time Assistance	200 ms
	Absolute GNSS signal level	0 dB
	Position error	1.3 m
	Response time	300 ms
5.4, 6.4, 7.3 Dynamic Range	Coarse Time Assistance	200 ms
	Absolute GNSS signal level	0 dB
	Relative GNSS signal level	0.2 dB
	Position error	1.3 m
	Response time	300 ms
5.5, 6.5, 7.4 Multi-path scenario	Coarse Time Assistance	200 ms
	Absolute GNSS signal level	0 dB
	Relative GNSS signal level	0.2 dB
	Position error	1.3 m
	Response time	300 ms
5.6, 6.6, 7.5 Moving scenario and periodic update	Absolute GNSS signal level	0 dB
	Position error	1.3 m
	Differential Response Time	100 ms

## C.2.2 ECID and OTDOA Measurement requirements

**Table C.2.2: Test Parameter Relaxations for ECID and OTDOA Measurement requirements**

Clause	Test Parameter Relaxation	
8.1.1 E-UTRAN FDD UE Rx – Tx time difference case		
8.1.2 E-UTRAN TDD UE Rx – Tx time difference case		
9.1.1 FDD RSTD Measurement Reporting Delay	Response time	300 ms
9.1.2 TDD RSTD Measurement Reporting Delay	Response time	300 ms
9.1.3 FDD RSTD Measurement Accuracy	For Test 2 and Test 4: PRS $\hat{E}s_1 / N_{oc}$ averaged over $BW_{Config}$	+0.3 dB
	PRS $\hat{E}s_2 / N_{oc}$ averaged over $BW_{Config}$	+0.3 dB
	For all tests: Cell Timing Difference	$\pm 1 T_s$
9.1.4 TDD RSTD Measurement Accuracy	Same as 9.1.3	Same as 9.1.3
9.2.1 FDD-FDD inter-frequency RSTD measurement reporting delay		
9.2.2 TDD-TDD inter-frequency RSTD measurement reporting delay		
9.2.4 FDD-FDD inter frequency RSTD Accuracy		
9.2.5 TDD-TDD inter frequency RSTD Accuracy		
10.1 FDD RSTD Measurement Reporting Delay for Carrier Aggregation		
10.2 TDD RSTD Measurement Reporting Delay for Carrier Aggregation		
10.3 FDD RSTD Measurement Accuracy for Carrier Aggregation		
10.4 TDD RSTD Measurement Accuracy for Carrier Aggregation		

## C.3 Interpretation of measurement results

The measurement results returned by the Test System are compared - without any modification - against the Test Requirements as defined by the shared risk principle.

The Shared Risk principle is defined in TR 102 273-1-2 [14], clause 6.5.

The actual measurement uncertainty of the Test System for the measurement of each parameter shall be included in the test report.

The recorded value for the Test System uncertainty shall be, for each measurement, equal to or lower than the appropriate figure in clause C.1.

If the Test System for a test is known to have a measurement uncertainty greater than that specified in clause C.1, it is still permitted to use this apparatus provided that an adjustment is made value as follows.

Any additional uncertainty in the Test System over and above that specified in clause C.1 shall be used to tighten the Test Requirement - making the test harder to pass. (This may require modification of stimulus signals). This procedure will ensure that a Test System not compliant with clause C.1 does not increase the chance of passing a device under test where that device would otherwise have failed the test if a Test System compliant with clause C.1 had been used.

## C.4 Derivation of Test Requirements (This clause is informative)

The Test Requirements have been calculated by relaxing the Conformance requirement of the core specification using the Test Parameter Relaxations defined in clause C.2. When the Test Parameter Relaxation is zero, the Test Requirement will be the same as the Conformance requirement. When the Test Parameter Relaxation is non-zero, the Test Requirements will differ from the Conformance requirement, and the formula used for this relaxation is given in table C.4.1 and C.4.2.

Table C.4.1: Derivation of Test Requirements for A-GNSS Minimum Performance tests

Test	Conformance requirement in 3GPP TS 25.171 or 3GPP TS 25.172 or 3GPP TS 36.171		Test Parameter Relaxation (TPR)	Test Requirement
5.2.1, 6.2.1, 7.1.1 Sensitivity Coarse Time Assistance	Coarse Time Assistance	±2 s	200 ms	Formulas: UL-TPR, LL+TPR: ±1.8 s
	Absolute GPS L1 C/A signal level (test 5.2.1 and test 7.1.1 sub-test 1) -142, -147 dBm	-142, -147 dBm	1 dB	Level + TPR: -141, -146 dBm
	Absolute GNSS signal level (Galileo)	-142, -147 dBm	1 dB	Level + TPR: -141, -146 dBm
	Absolute GNSS signal level (GPS) (test 6.2.1 and test 7.1.1 sub-tests 2 to 5)	-142, -147 dBm	1 dB	Level + TPR: -141, -146 dBm
	Absolute GNSS signal level (GLONASS)	-142, -147 dBm	1 dB	Level + TPR: -141, -146 dBm
	Position error	100 m	1.3 m	Error +TPR: 101.3 m
	Response time	20 s	300 ms	Time + TPR: 20.3 s
5.2.2, 6.2.2, 7.1.2 Sensitivity Fine Time Assistance	Coarse Time Assistance	±2 s	200 ms	Formulas: UL-TPR, LL+TPR: ±1.8 s
	Fine Time Assistance	±10 us	1 us	UL-TPR, LL+TPR: ±9 us
	Absolute GPS L1 C/A signal level (test 5.2.2 and test 7.1.2 sub-test 1) -142, -147 dBm	-147 dBm	1 dB	Level + TPR: -146 dBm
	Absolute GNSS signal level (Galileo)	-147 dBm	1 dB	Level + TPR: -146 dBm
	Absolute GNSS signal level (GPS) (test 6.2.2 and test 7.1.2 sub-tests 2 to 5)	-147 dBm	1 dB	Level + TPR: -146 dBm
	Absolute GNSS signal level (GLONASS)	-147 dBm	1 dB	Level + TPR: -146 dBm
	Position error	100 m	1.3 m	Error +TPR: 101.3 m
Response time	20 s	300 ms	Time + TPR: 20.3 s	
5.3, 6.3, 7.2 Nominal Accuracy	Coarse Time Assistance	±2 s	200 ms	Formulas: UL-TPR, LL+TPR: ±1.8 s
	Absolute GPS L1 C/A signal level (test 5.3 and test 7.2 sub-test 1) -142, -147 dBm	-130 dBm	0 dB	Formulas: Level + TPR: -130 dBm
	Absolute GNSS signal level (Galileo)	-127 dBm	0 dB	Level + TPR: -127 dBm
	Absolute GNSS signal level (GPS) (test 6.3 and test 7.2 sub-tests 2 to 5)	-128.5 dBm	0 dB	Level + TPR: -128.5 dBm
	Absolute GNSS signal level (GLONASS)	-131 dBm	0 dB	Level + TPR: -131 dBm
	Absolute GNSS signal level (QZSS)	-128.5 dBm	0 dB	Level + TPR: -128.5 dBm
	Absolute GNSS signal level (SBAS)	-131 dBm	0 dB	Level + TPR: -131 dBm
	Position error	30 m	1.3 m	Error +TPR: 31.3 m
	Response time	20 s	300 ms	Time + TPR: 20.3 s
5.4, 6.4, 7.3 Dynamic Range	Coarse Time Assistance	±2 s	200 ms	Formulas: UL-TPR, LL+TPR: ±1.8 s
	Absolute GPS L1 C/A signal level (test 5.4 and test 7.3 sub-test 1) -142, -147 dBm	-129 to -147 dBm	1 dB	Level + TPR: each level +1 dBm
	Absolute GNSS signal level (Galileo)	-127.5 to -147 dBm	1 dB	Level + TPR: each level +1 dBm
	Absolute GNSS signal level (GPS) (test 6.4 and test 7.3 sub-tests 2 to 5)	-129 to -147 dBm	1 dB	Level + TPR: each level +1 dBm

Test	Conformance requirement in 3GPP TS 25.171 or 3GPP TS 25.172 or 3GPP TS 36.171		Test Parameter Relaxation (TPR)	Test Requirement
	Absolute GNSS signal level (GLONASS)	-131.5 to -147 dBm	1 dB	Level + TPR: each level +1 dBm
	Relative GPS L1 C/A signal level (test 5.4 and test 7.3 sub-test 1) -142, -147 dBm	18 dB	0.2 dB	Level - TPR: highest level -0.2 dB: -128.2 dBm
	Relative GNSS signal level (Galileo)	19.5 dB	0.2 dB	Level - TPR: highest level -0.2 dB: -126.7 dBm
	Relative GNSS signal level (GPS) (test 6.4 and test 7.3 sub-tests 2 to 5)	18 dB	0.2 dB	Level - TPR: highest level -0.2 dB: -128.2 dBm
	Relative GNSS signal level (GLONASS)	15.5 dB	0.2 dB	Level - TPR: highest level -0.2 dB: -130.7 dBm
	Position error	100 m	1.3 m	Error +TPR: 101.3 m
	Response time	20 s	300 ms	Time + TPR: 20.3 s
	5.5, 6.5, 7.4 Multi-path scenario	Coarse Time Assistance	±2 s	200 ms
Absolute GPS L1 C/A signal level (test 5.5 and test 7.4 sub-test 1) -142, -147 dBm		-130 dBm	0 dB	Formulas: Level + TPR: -130 dBm
Absolute GNSS signal level (Galileo)		-127 dBm	0 dB	Level + TPR: -127 dBm
Absolute GNSS signal level (GPS) (test 6.5 and test 7.4 sub-tests 2 to 5)		-128.5 dBm	0 dB	Level + TPR: -128.5 dBm
Absolute GNSS signal level (GLONASS)		-131 dBm	0 dB	Level + TPR: -131 dBm
Relative GPS L1 C/A signal level (test 5.5 and test 7.4 sub-test 1) -142, -147 dBm		6 dB	0.2 dB	Relative level + TPR: relative level + 0.2dB: 6.2 dB
Relative GNSS signal level (all GNSSs) (test 6.5 and test 7.4 sub-tests 2 to 5)		Y dB where "Y" is given in Table 70.16.2.1	0.2 dB	Relative level + TPR: relative level + 0.2dB: Y + 0.2 dB
Position error		100 m	1.3 m	Error +TPR: 101.3 m
Response time		20 s	300 ms	Time + TPR: 20.3 s
5.6, 6.6, 7.5 Moving scenario and periodic update	Absolute GPS L1 C/A Signal level (test 5.6 and test 7.5 sub-test 1) -130 dBm	-130 dBm	0 dB	Formulas: Level + TPR: -130 dBm
	Absolute GNSS signal level (Galileo)	-127 dBm	0 dB	Level + TPR: -127 dBm
	Absolute GNSS signal level (GPS) (test 6.6 and test 7.5 sub-tests 2 to 5)	-128.5 dBm	0 dB	Level + TPR: -128.5 dBm
	Absolute GNSS signal level (GLONASS)	-131 dBm	0 dB	Level + TPR: -131 dBm
	Position error 100 m	100 m	1.3 m	Error +TPR: 101.3 m
	Differential response time	2s +/- 20 %	100 ms	Time +TPR: 1.5 s and 2.5 s



Table C.4.2: Derivation of Test Requirements for ECID and OTDOA Measurement tests

Test	Minimum Requirement in TS 36.133	Test Parameter Relaxation (TPR)	Test Requirement in TS 36.571-1
8.1.1 E-UTRAN FDD UE Rx – Tx time difference case	<p><u>Test 1:</u>  <math>N_{oc}</math>: -98dBm/15kHz  <math>\hat{E}_s / N_{oc}</math>: -3.0dB  <u>Reported RxTx time difference value:</u> Measured value converted to RX-TX_TIME_DIFFERENCE according to Table 8.1.1.3-2</p> <p><u>Test 2:</u>  <math>N_{oc}</math>: -98dBm/15kHz  <math>\hat{E}_s / N_{oc}</math>: -3.0dB  <u>Reported RxTx time difference value:</u> Measured value converted to RX-TX_TIME_DIFFERENCE according to Table 8.1.1.3-2</p>	<p><u>Test 1:</u>  0dB  0.3dB  Via mapping</p> <p><u>Test 2:</u>  0dB  0.3dB  Via mapping</p>	<p><u>Test 1:</u>  <math>N_{oc}</math>: -98dBm/15kHz  <math>\hat{E}_s / N_{oc}</math>: -2.7.0dB  (Measured value from step 7 - 23) <math>T_s</math> converted to RX-TX_TIME_DIFFERENCE according to Table 4.6.3-1  <u>To</u>  (Measured value from step 7 +23) <math>T_s</math> converted to RX-TX_TIME_DIFFERENCE according to Table 4.6.3-1</p> <p><u>Test 2:</u>  <math>N_{oc}</math>: -88dBm/15kHz  <math>\hat{E}_{s1} / N_{oc}</math>: +6.0dB  <math>\hat{E}_{s2} / N_{oc}</math>: +2.0dB  Measured value from step 7 -13) <math>T_s</math> converted to RX-TX_TIME_DIFFERENCE according to Table 4.6.3-1  <u>To</u>  (Measured value from step 7 +13) <math>T_s</math> converted to RX-TX_TIME_DIFFERENCE according to Table 4.6.3-1</p>
8.1.2 E-UTRAN TDD UE Rx – Tx time difference case	Same as 8.1.1	Same as 8.1.1	Same as 8.1.1
9.1.1 FDD RSTD Measurement Reporting Delay	Response Time = 3 s	300 ms	Time + TPR: 3.3 s
9.1.2 TDD RSTD Measurement Reporting Delay	Response Time = 3 s	300 ms	Time + TPR: 3.3 s
9.1.3 FDD RSTD Measurement Accuracy	<p>For Test 2 and Test 4:  PRs <math>\hat{E}_{s1} / N_{oc}</math> = -6dB  PRs <math>\hat{E}_{s2} / N_{oc}</math> = -13dB</p> <p>For All Tests:  See Table 9.1.3.3-1 for measurement accuracy.</p>	<p>+0.3 dB  +0.3 dB</p> <p><math>\pm 1 T_s</math></p>	<p>Level + TPR, -5.7 dB  Level + TPR, -12.7 dB</p> <p>See Table 9.1.3.5-2.</p>
9.1.4 TDD RSTD Measurement Accuracy	<u>Same as 9.1.3</u>		
9.2.1 FDD-FDD inter-frequency RSTD measurement reporting delay			
9.2.2 TDD-TDD inter-frequency RSTD measurement reporting delay			
9.2.4 FDD-FDD inter frequency RSTD Accuracy			
9.2.5 TDD-TDD inter frequency RSTD Accuracy			
10.1 FDD RSTD Measurement Reporting Delay for Carrier Aggregation			

10.2 TDD RSTD Measurement Reporting Delay for Carrier Aggregation			
10.3 FDD RSTD Measurement Accuracy for Carrier Aggregation			
10.4 TDD RSTD Measurement Accuracy for Carrier Aggregation			

---

## Annex D (normative): Rules for statistical testing

### D.1 Test Method

In this clause the terms GNSS and A-GNSS also include the cases where the only satellite system used is GPS unless otherwise stated.

Each test is performed in the following manner:

- a) Setup the required test conditions.
- b) Start each repetition after having applied the message 'RESET UE POSITIONING STORED INFORMATION'. This ensures that each result is independent from the previous one.
- c) Make the required measurement a repeated number of times. The results, measured, are simplified to:

good result, if the measured result is  $\leq$  limit.

bad result, if the measured result is  $>$  limit

For the relevant A-GNSS test cases measure the 2D position and Time to First Fix (TTFF) a repeated number of times. Measure the 2D position and Time to First Fix (if applicable) repeated times. Start each repetition after having applied the message 'RESET UE POSITIONING STORED INFORMATION'. This ensures that each result is independent from the previous one. The results, measured, are simplified to:

good result, if the 2D position and TTFF are  $\leq$  limit.

bad result, if the 2D position or TTFF or both are  $>$  limit

- d) Record the number of results (ns) and the number of bad results (ne)
- e) Stop the test at a pass or a fail event.
- f) Once the test is stopped, decide according to the pass fail decision rules (D.4.2)

### D.2 Error Ratio (ER)

The Error Ratio (ER) is defined as the ratio of bad results (ne) to all results (ns).  
(1-ER is the success ratio)

### D.3 Test Design

A statistical test is characterised by:

Test-time, Selectivity and Confidence level

#### D.3.1 Confidence level

The outcome of a statistical test is a decision. This decision may be correct or in-correct. The Confidence Level CL describes the probability that the decision is a correct one. The complement is the wrong decision probability (risk)  $D = 1-CL$

#### D.3.2 Introduction: Supplier Risk versus Customer Risk

There are two targets of decision:

- a) A measurement on the pass-limit shows, that the DUT has the specified quality or is better with probability CL (CL e.g.95%) This shall lead to a “pass decision”

The pass-limit is on the good side of the specified DUT-quality. A more stringent CL (CL e.g.99%) shifts the pass-limit further into the good direction. Given that the quality of the DUTs is distributed, a greater CL passes less and better DUTs.

A measurement on the bad side of the pass-limit is simply “not pass” (undecided)

- aa) Complementary:

A measurement on the fail-limit shows, that the DUT is worse than the specified quality with probability CL.

The fail-limit is on the bad side of the specified DUT-quality. A more stringent CL shifts the fail-limit further into the bad direction. Given that the quality of the DUTs is distributed, a greater CL fails less and worse DUTs.

A measurement on the good side of the fail-limit is simply “not fail”.

- b) A DUT, known to have the specified quality, shall be measured and decided pass with probability CL. This leads to the pass limit.

For CL e.g. 95%, the pass limit is on the bad side of the specified DUT-quality. CL e.g.99% shifts the pass-limit further into the bad direction. Given that the DUT-quality is distributed, a greater CL passes more and worse DUTs.

- bb) A DUT, known to be an ( $\epsilon \rightarrow 0$ ) beyond the specified quality, shall be measured and decided fail with probability CL.

For CL e.g.95%, the fail limit is on the good side of the specified DUT-quality.

Note the different sense for CL in (a), (aa) versus (b), (bb).

NOTE: For constant CL in all 4 bullets, (a) is equivalent to (bb) and (aa) is equivalent to (b).

### D.3.3 Supplier Risk versus Customer Risk

The table below summarizes the different targets of decision.

**Table D.3.3: Equivalent statements**

	Equivalent statements, using different cause-to-effect-directions, and assuming CL = constant >0.5	
cause-to-effect-directions	Known measurement result $\rightarrow$ estimation of the DUT's quality	Known DUT's quality $\rightarrow$ estimation of the measurement's outcome
Supplier Risk	<b>A measurement on the pass-limit shows, that the DUT has the specified quality or is better (a)</b>	A DUT, known to have an ( $\epsilon \rightarrow 0$ ) beyond the specified DUT-quality, shall be measured and decided fail (bb)
Customer Risk	A measurement on the fail-limit shall shows, that the DUT is worse than the specified quality (aa)	<b>A DUT, known to have the specified quality, shall be measured and decided pass (b)</b>

NOTE: The bold text shows the obvious interpretation of Supplier Risk and Customer Risk. The same statements can be based on other DUT-quality-definitions.

### D.3.4 Introduction: Standard test versus early decision concept

In standard statistical tests, a certain number of results (ns) is predefined in advance of the test. After ns results the number of bad results (ne) is counted and the error ratio (ER) is calculated as ne/ns.

Applying statistical theory, a decision limit can be designed, against which the calculated ER is compared to derive the decision. Such a limit is one decision point and is characterised by:

- D: the wrong decision probability (a predefined parameter)
- ns: the number of results (a fixed predefined parameter)
- ne: the number of bad results (the limit based on just ns)

In the formula for the limit, D and ns are parameters and ne is the variable. In the standard test ns and D are constant. The property of such a test is: It discriminates between two states only, depending on the test design:

- pass (with CL) / undecided (undecided in the sense: finally undecided)
- fail (with CL) / undecided (undecided in the sense: finally undecided)
- pass (with CL) / fail (with CL) (however against two limits).

In contrast to the standard statistical tests, the early decision concept predefines a set of (ne, ns) co-ordinates, representing the limit-curve for decision. After each result a preliminary ER is calculated and compared against the limit-curve. After each result one may make the decision or not (undecided for later decision). The parameters and variables in the limit-curve for the early decision concept have a similar but not equal meaning:

- D: the wrong decision probability (a predefined parameter)
- ns: the number of results (a variable parameter)
- ne: the number of bad results (the limit. It varies together with ns)

To avoid a “final undecided” in the standard test, a second limit must be introduced and the single decision co-ordinate (ne, ns) needs a high ne, leading to a fixed (high) test time. In the early decision concept, having the same selectivity and the same confidence level an “undecided” does not need to be avoided, as it can be decided later. A perfect DUT will hit the decision coordinate (ne, ns) with ne=0. This test time is short.

### D.3.5 Standard test versus early decision concept

For Supplier Risk:

The wrong decision probability D in the standard test is the probability, to decide a DUT in -correctly in the single decision point. In the early decision concept there is a probability of in -correct decisions d at each point of the limit-curve. The sum of all those wrong decision probabilities accumulate to D. Hence  $d < D$

For Customer Risk:

The correct decision probability CL in the standard test is the probability, to decide a DUT correctly in the single decision point. In the early decision concept there is a probability of correct decisions cl at each point of the limit-curve. The sum of all those correct decision probabilities accumulate to CL. Hence  $cl < CL$  or  $d > D$

### D.3.6 Selectivity

There is no statistical test which can discriminate between a limit -DUT-quality and a DUT-quality which is an ( $\epsilon \rightarrow 0$ ) apart from the limit in finite time and confidence level  $CL > 1/2$ . Either the test discriminates against one limit with the results pass (with CL)/undecided or fail (with CL)/undecided, or the test ends in a result pass (with CL)/fail (with CL) but this requires a second limit.

For  $CL > 0.5$ , a (measurement-result = specified-DUT-quality), generates undecided in test “supplier risk against pass limit” (a in clause D.3.2) and also in the equivalent test against the fail limit (aa in clause D.3.2)

For  $CL > 0.5$ , a DUT, known to be on the limit, will be decided pass for the test “customer risk against pass limit” (b in clause D.3.2) and also in the equivalent test against fail limit (bb in clause D.3.2).

This overlap or undecided area is not a fault or a contradiction, however it can be avoided by introducing a Bad or a Good DUT quality according to:

- Bad DUT quality: specified DUT-quality \* M ( $M > 1$ )
- Good DUT quality: specified DUT-quality \* m ( $m < 1$ )

Using e.g.  $M > 1$  and  $CL = 95\%$  the test for different DUT qualities yield different pass probabilities:

Figure D.3.6: Pass probability versus DUT quality

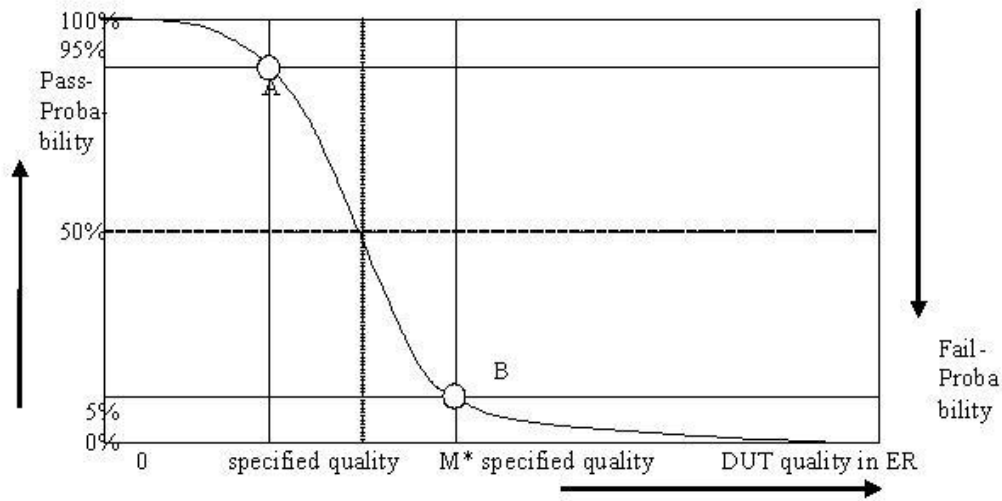

### D.3.7 Design of the test

The test is defined according to the following design principles:

1. The early decision concept is applied.
2. A second limit is introduced: Bad DUT factor  $M > 1$
3. To decide the test pass:

Supplier risk is applied based on the Bad DUT quality

To decide the test fail

Customer Risk is applied based on the specified DUT quality

The A-GNSS test cases are defined using the following parameters:

1. Specified DUT quality: ER = 0.05
2. Bad DUT quality:  $M = 1.5$  (selectivity)
3. Confidence level CL = 95% (for specified DUT and Bad DUT-quality)

The ECID and OTDOA test cases are defined using the following parameters:

1. Specified DUT quality: ER = 0.1
2. Bad DUT quality:  $M = 1.5$  (selectivity)
3. Confidence level CL = 95% (for specified DUT and Bad DUT-quality)

This has the following consequences:

- a) A measurement on the fail-limit is connected with 2 equivalent statements:

A measurement on the fail-limit shows, that the DUT is worse than the specified DUT-quality	A DUT, known to have the specified quality, shall be measured and decided pass
---	--

A measurement on the pass limit is connected with the complementary statements:

A measurement on the pass limit shows, that the DUT is better than the Bad DUT-quality.	A DUT, known to have the Bad DUT quality, shall be measured and decided fail
---	--

The left column is used to decide the measurement.

The right column is used to verify the design of the test by simulation.

The simulation is based on the two fulcrums A and B only in Figure D.3.6. There is freedom to shape the remainder of the function.

b) Test time

1. The minimum and maximum test time is fixed.
  2. The average test time is a function of the DUT's quality.
  3. The individual test time is not predictable (except ideal DUT).
- c) The number of decision co-ordinates (ne, ns) in the early decision concept is responsible for the selectivity of the test and the maximum test time. Having fixed the number of decision co-ordinates there is still freedom to select the individual decision co-ordinates in many combinations, all leading to the same confidence level.

## D.4 Pass fail decisions

### D.4.1 Numerical definition of the pass fail limits for A-GNSS test cases

ne	ns <sub>p</sub>	ns <sub>f</sub>	ne	ns <sub>p</sub>	ns <sub>f</sub>	ne	ns <sub>p</sub>	ns <sub>f</sub>	ne	ns <sub>p</sub>	ns <sub>f</sub>
0	77	NA	43	855	576	86	1525	1297	129	2173	2050
1	106	NA	44	871	592	87	1540	1314	130	2188	2067
2	131	NA	45	887	608	88	1556	1331	131	2203	2085
3	154	NA	46	903	625	89	1571	1349	132	2218	2103
4	176	NA	47	919	641	90	1586	1366	133	2233	2121
5	197	NA	48	935	657	91	1601	1383	134	2248	2139
6	218	42	49	951	674	92	1617	1401	135	2263	2156
7	238	52	50	967	690	93	1632	1418	136	2277	2174
8	257	64	51	982	706	94	1647	1435	137	2292	2192
9	277	75	52	998	723	95	1662	1453	138	2307	2210
10	295	87	53	1014	739	96	1677	1470	139	2322	2227
11	314	100	54	1030	756	97	1692	1487	140	2337	2245
12	333	112	55	1046	772	98	1708	1505	141	2352	2263
13	351	125	56	1061	789	99	1723	1522	142	2367	2281
14	369	139	57	1077	805	100	1738	1540	143	2381	2299
15	387	152	58	1093	822	101	1753	1557	144	2396	2317
16	405	166	59	1108	839	102	1768	1574	145	2411	2335
17	422	180	60	1124	855	103	1783	1592	146	2426	2352
18	440	194	61	1140	872	104	1798	1609	147	2441	2370
19	457	208	62	1155	889	105	1813	1627	148	2456	2388
20	474	222	63	1171	906	106	1828	1644	149	2470	2406
21	492	237	64	1186	922	107	1844	1662	150	2485	2424
22	509	251	65	1202	939	108	1859	1679	151	2500	2442
23	526	266	66	1217	956	109	1874	1697	152	2515	2460
24	543	281	67	1233	973	110	1889	1714	153	2530	2478
25	560	295	68	1248	990	111	1904	1732	154	2544	2496
26	577	310	69	1264	1007	112	1919	1750	155	2559	2513
27	593	325	70	1279	1024	113	1934	1767	156	2574	2531
28	610	341	71	1295	1040	114	1949	1785	157	2589	2549
29	627	356	72	1310	1057	115	1964	1802	158	2603	2567
30	643	371	73	1326	1074	116	1979	1820	159	2618	2585
31	660	387	74	1341	1091	117	1994	1838	160	2633	2603
32	676	402	75	1357	1108	118	2009	1855	161	2648	2621
33	693	418	76	1372	1126	119	2024	1873	162	2662	2639
34	709	433	77	1387	1143	120	2039	1890	163	2677	2657
35	725	449	78	1403	1160	121	2054	1908	164	2692	2675
36	742	465	79	1418	1177	122	2069	1926	165	2707	2693
37	758	480	80	1433	1194	123	2084	1943	166	2721	2711
38	774	496	81	1449	1211	124	2099	1961	167	2736	2729
39	790	512	82	1464	1228	125	2114	1979	168	2751	2747
40	807	528	83	1479	1245	126	2128	1997	169	2765	NA
41	823	544	84	1495	1263	127	2143	2014			
42	839	560	85	1510	1280	128	2158	2032			

NOTE: The first column is the number of bad results (ne)  
 The second column is the number of results for the pass limit (ns<sub>p</sub>)  
 The third column is the number of results for the fail limit (ns<sub>f</sub>)

### D.4.2 Pass fail decision rules for A-GNSS test cases

Having observed 0 bad results, pass the test at  $\geq 77$  results, otherwise continue

Having observed 1 bad result, pass the test at  $\geq 106$  results, otherwise continue

Having observed 2 bad results, pass the test at  $\geq 131$  results, otherwise continue

etc. until

Having observed 6 bad results, pass the test at  $\geq 218$  results, fail the test at  $\leq 42$  results, otherwise continue



Having observed 7 bad results, pass the test at  $\geq 238$  results, fail the test at  $\leq 52$  results, otherwise continue

etc. until

Having observed 168 bad results, pass the test at  $\geq 2751$  results, fail the test at  $\leq 2747$  results, otherwise continue

Having observed 169 bad results, pass the test at  $\geq 2765$  results, otherwise fail

NOTE: an ideal DUT passes after 77 results. The maximum test time is 2765 results.

### D.4.3 Numerical definition of the pass fail limits for ECID and OTDOA test cases

ne	ns <sub>p</sub>	ns <sub>f</sub>	ne	ns <sub>p</sub>	ns <sub>f</sub>	ne	ns <sub>p</sub>	ns <sub>f</sub>	ne	ns <sub>p</sub>	ns <sub>f</sub>
0	33	NA	43	408	283	86	737	644	129	1056	1021
1	46	NA	44	416	291	87	745	653	130	1064	1030
2	58	2	45	424	299	88	752	661	131	1071	1039
3	69	5	46	432	307	89	760	670	132	1078	1048
4	79	8	47	440	315	90	767	679	133	1086	1057
5	89	12	48	447	324	91	775	687	134	1093	1066
6	99	17	49	455	332	92	782	696	135	1100	1074
7	109	22	50	463	340	93	790	705	136	1108	1083
8	118	27	51	471	348	94	797	713	137	1115	1092
9	127	33	52	478	356	95	804	722	138	1122	1101
10	136	39	53	486	365	96	812	731	139	1130	1110
11	145	45	54	494	373	97	819	739	140	1137	1119
12	154	51	55	502	381	98	827	748	141	1144	1128
13	163	58	56	509	389	99	834	757	142	1152	1137
14	172	64	57	517	398	100	842	766	143	1159	1147
15	180	71	58	525	406	101	849	774	144	1166	1155
16	189	78	59	532	414	102	857	783	145	1174	1164
17	197	85	60	540	423	103	864	792	146	1181	1173
18	206	92	61	548	431	104	871	801	147	NA	1182
19	214	99	62	555	440	105	879	809	148		
20	223	106	63	563	448	106	886	818	149		
21	231	113	64	571	456	107	894	827	150		
22	239	120	65	578	465	108	901	836	151		
23	248	128	66	586	473	109	909	844	152		
24	256	135	67	594	482	110	916	853	153		
25	264	142	68	601	490	111	923	862	154		
26	272	150	69	609	499	112	931	871	155		
27	281	157	70	616	507	113	938	880	156		
28	289	165	71	624	516	114	946	888	157		
29	297	173	72	632	524	115	953	897	158		
30	305	180	73	639	533	116	960	906	159		
31	313	188	74	647	541	117	968	915	160		
32	321	196	75	654	550	118	975	924	161		
33	329	204	76	662	558	119	983	933	162		
34	337	211	77	669	567	120	990	941	163		
35	345	219	78	677	575	121	997	950	164		
36	353	227	79	684	584	122	1005	959	165		
37	361	235	80	692	592	123	1012	968	166		
38	369	243	81	700	601	124	1019	977	167		
39	377	251	82	707	610	125	1027	986	168		
40	385	259	83	715	618	126	1034	994	169		
41	393	267	84	722	627	127	1042	1003			
42	400	275	85	730	635	128	1049	1012			

The first column is the number of errors (ne = number of exceeded delays or number of wrong reports)

The second column is the number of samples for the pass limit (ns<sub>p</sub>, ns=Number of samples= number of successes + number of exceedings or number of reports)

The third column is the number of samples for the fail limit (ns<sub>f</sub>)

## D.4.4 Pass fail decision rules for ECID and OTDOA test cases

Having observed 0 errors, pass the test at 33+ samples, otherwise continue

Having observed 1 error, pass the test at 46+ samples, otherwise continue

Having observed 2 errors, pass the test at 58+ samples, fail the test at 2 samples, otherwise continue

Having observed 146 errors, pass the test at 1181+ samples, fail the test at 1173- samples, otherwise continue

Having observed 147 errors, fail the test at 1182- samples,

Where x+ means: x or more, x- means x or less

NOTE: an ideal DUT passes after 33 samples. The maximum test time is 1181 samples.

## D.4.5 Background information to the pass fail limits

There is freedom to design the decision co-ordinates (ne, ns).

The binomial distribution and its inverse is used to design the pass and fail limits. Note that this method is not unique and that other methods exist.

$$\text{fail}(ne, d_f) := \frac{ne}{(ne + \text{qnbino}(d_f, ne, ER))}$$

$$\text{pass}(ne, c_p, M) := \frac{ne}{(ne + \text{qnbino}(c_p, ne, ER \cdot M))}$$

Where

fail(..) is the error ratio for the fail limit

pass(..) is the error ratio for the pass limit

ER is the specified error ratio e.g. 0.05

ne is the number of bad results. This is the variable in both equations

M is the Bad DUT factor M=1.5

d<sub>f</sub> is the wrong decision probability of a single (ne, ns) co-ordinate for the fail limit.

It is found by simulation to be d<sub>f</sub> = 0.004

c<sub>p</sub> is the confidence level of a single (ne, ns) co-ordinate for the pass limit.

It is found by simulation to be c<sub>p</sub> = 0.9975

qnbino(..): The inverse cumulative function of the negative binomial distribution

The simulation works as follows:

A large population of limit DUTs with true ER = 0.05 is decided against the pass and fail limits.

c<sub>p</sub> and d<sub>f</sub> are tuned such that CL(95%) of the population passes and D(5%) of the population fails.

A population of Bad DUTs with true ER = M\*0.05 is decided against the same pass and fail limits.

c<sub>p</sub> and d<sub>f</sub> are tuned such that CL(95%) of the population fails and D(5%) of the population passes.

This procedure and the relationship to the measurement is justified in clause D.3.7. The number of DUTs decreases during the simulation, as the decided DUTs leave the population. That number decreases with an approximately exponential characteristics. After 169 bad results all DUTs of the population are decided.

NOTE: The exponential decrease of the population is an optimal design goal for the decision co-ordinates (ne, ns), which can be achieved with other formulas or methods as well.

## Annex E (normative): Conditions for ECID and OTDOA requirements applicability for operating bands

### E.1 Conditions for E-CID Measurements

This clause defines the E-UTRAN RSRP applicable for a corresponding operating band

The conditions for E-UTRAN ECID UE Rx-Tx time difference measurements are defined in Table E.1-1

**Table E.1-1: E-UTRA ECID UE Rx-Tx time difference measurements**

Parameter	E-UTRA operating bands	Minimum RSRP Note 1
		dBm/15kHz
Conditions	1, 4, 6, 10, 11, 18, 19, 21, 23, 24, 33, 34, 35, 36, 37, 38, 39, 40	-127
	9, 42, 43	-126
	28	-125.5
	2, 5, 7, 27, 41, [44]	-125
	26	-124.5 <sup>Note 2</sup>
	3, 8, 12, 13, 14, 17, 20, 22, 29 <sup>Note 3</sup>	-124
	25	-123.5
NOTE 1: For a UE supporting a band combination of E-UTRA carrier aggregation with one uplink carrier configuration, if there is a relaxation of receiver sensitivity $\Delta RIB,c$ as defined in TS 36.101 [2] due to the CA configuration, the RSRP measurement side condition shall be increased by the amount $\Delta RIB,c$ defined for the corresponding downlink band.		
NOTE 2: The condition is -125 dBm/15kHz when the carrier frequency of the assigned E-UTRA channel bandwidth is within 865-894 MHz.		
NOTE 3: Band 29 is used only for E-UTRA carrier aggregation with other E-UTRA bands.		

### E.2 Conditions for OTDOA intra-frequency RSTD Measurements

This clause defines the E-UTRAN intra-frequency PRP<sub>1,2</sub> applicable for a corresponding operating band.

The conditions for E-UTRAN OTDOA intra-frequency RSTD measurements are defined in Table E.2-1

**Table E.2-1: E-UTRAN OTDOA intra-frequency RSTD measurements**

Parameter	E-UTRA operating bands	Minimum PRP <sub>1,2</sub> Note 1
		dBm/15kHz
Conditions	1, 4, 6, 10, 11, 18, 19, 21, 23, 24, 33, 34, 35, 36, 37, 38, 39, 40	-127
	9, 42, 43	-126
	28	-125.5
	2, 5, 7, 27, 41, [44]	-125
	26	-124.5 <sup>Note 2</sup>
	3, 8, 12, 13, 14, 17, 20, 22, 29 <sup>Note 3</sup>	-124
	25	-123.5
NOTE 1: For a UE supporting a band combination of E-UTRA carrier aggregation with one uplink carrier configuration, if there is a relaxation of receiver sensitivity $\Delta RIB,c$ as defined in TS 36.101 [2] due to the CA configuration, the PRP measurement side condition shall be increased by the amount $\Delta RIB,c$ defined for the corresponding downlink band.		
NOTE 2: The condition is -125 dBm/15kHz when the carrier frequency of the assigned E-UTRA channel bandwidth is within 865-894 MHz.		
NOTE 3: Band 29 is used only for E-UTRA carrier aggregation with other E-UTRA bands.		

## E.3 Conditions for OTDOA inter-frequency RSTD Measurements

This clause defines the E-UTRAN inter-frequency PRP\_1,2 applicable for a corresponding operating band.

The conditions for E-UTRAN OTDOA inter-frequency RSTD measurements are defined in Table E.2-1.

## Annex F (normative): UTRAN Generic procedures

### F.1 General

This normative annex specifies the set up and release procedure that shall be used for each UTRAN test case.

In this clause the terms GNSS and A-GNSS also include the cases where the only satellite system used is GPS unless otherwise stated.

### F.2 UTRAN connection set up

#### F.2.1 Initial conditions

System Simulator:

- 1 cell, default parameters. The default system information, as specified in clause 6.1 of TS 34.108 [28], is broadcast with the exceptions of SIB15, SIB15.1, SIB15.2 and SIB15.3 which are not broadcast.

User Equipment:

- The UE shall be operated in Normal Propagation Conditions as specified in clause 5.2.1 of TS 34.108 [28].
- The UE is in state "MM idle" state with valid TMSI and CKSN.
- The UE is in state "PMM idle" with valid P-TMSI.

#### F.2.2 Procedures

CS Domain

Step	Direction		Message	Comments
	UE	SS		
1	<--		SYSTEM INFORMATION (BCCH)	Broadcast
2	<--		PAGING TYPE1 (PCCH)	Paging (CS domain, TMSI)
3	-->		RRC CONNECTION REQUEST (CCCH)	RRC
4	<--		RRC CONNECTION SETUP (CCCH)	RRC
5	-->		RRC CONNECTION SETUP COMPLETE (DCCH)	RRC
6	-->		PAGING RESPONSE	RR
7	<--		AUTHENTICATION REQUEST	MM
8	-->		AUTHENTICATION RESPONSE	MM
9	<--		SECURITY MODE COMMAND	RRC
10	-->		SECURITY MODE COMPLETE	RRC

PS Domain

Step	Direction		Message	Comments
	UE	SS		
1	<--		PAGING TYPE1 (PCCH)	Paging (PS domain, PMSI or IMSI)
2	-->		RRC CONNECTION REQUEST (CCCH)	RRC
3	<--		RRC CONNECTION SETUP (CCCH)	RRC
4	-->		RRC CONNECTION SETUP COMPLETE (DCCH)	RRC (Transport Channel: DCH or FACH)
5	-->		SERVICE REQUEST	GMM
6	<--		AUTHENTICATION REQUEST	GMM
7	-->		AUTHENTICATION RESPONSE	GMM
8	<--		SECURITY MODE COMMAND	RRC
9	-->		SECURITY MODE COMPLETE	RRC

### F.2.3 Specific message contents

The default message contents specified in clause 9.1 of TS 34.108 [28] will be used for the Moving Scenario and Periodic Update test. For all Minimum Performance TTFB Tests the default message contents specified in clause 9.1 of TS 34.108 [28] will be used with the following exception.

Contents of PAGING TYPE1:

Information Element	Value/remark
Paging Cause	Terminating High Priority Signalling

Contents of RRC CONNECTION SETUP:

For A-GNSS performance testing in CELL\_DCH state: The RRC Connection Setup is defined in clause 9.1.1 of TS 34.108 [28] "Contents of RRC CONNECTION SETUP message: UM (Transition to CELL\_DCH)".

For A-GNSS performance testing in CELL\_FACH state: The RRC Connection Setup is defined in clause 9.1.1 of TS 34.108 [28] "Contents of RRC CONNECTION SETUP message: UM (Transition to CELL\_FACH)".

Contents of RRC CONNECTION SETUP COMPLETE:

Information Element	Value/remark
UE radio access capability - UE positioning capability	Defines the A-GNSS mode the UE supports (UE-based, UE-assisted, or both). UE shall be tested for all modes it supports.

## F.3 UTRAN connection release

### F.3.1 Procedure

Step	Direction		Message	Comments
	UE	SS		
1	<--		RRC CONNECTION RELEASE	RRC
2	-->		RRC CONNECTION RELEASE COMPLETE	RRC

### F.3.2 Specific message contents

The default message contents specified in clause 9.1 of TS 34.108 [28] are used.

---

## Annex G (normative): Environmental conditions

### G.1 General

This normative annex specifies the environmental requirements of the UE. Within these limits the requirements of the present documents shall be fulfilled.

### G.2 Environmental requirements

The requirements in this clause apply to all types of UE(s).

#### G.2.1 Temperature

The UE shall fulfil all the requirements in the full temperature range of:

**Table G.2.1.1**

+15°C to +35°C	for normal conditions (with relative humidity up to 75 %)
----------------	---

#### G.2.2 Voltage

The UE shall fulfil all the requirements in the full voltage range, i.e. the voltage range between the extreme voltages.

The manufacturer shall declare the lower and higher extreme voltages and the approximate shutdown voltage. For the equipment that can be operated from one or more of the power sources listed below, the lower extreme voltage shall not be higher, and the higher extreme voltage shall not be lower than that specified below.

**Table G.2.2.1**

Power source	Normal conditions voltage
AC mains	nominal
Regulated lead acid battery	1.1 × nominal
Non regulated batteries:	
- Leclanché / lithium	Nominal
- Mercury/nickel and cadmium	Nominal



---

## Annex H (informative): Change history

Change history							
Date	TSG #	TSG Doc.	CR	Rev	Subject/Comment TS 36.571-1	Old	New
2010-08	RAN5#48	R5-104316			Initial draft TS 36.571-1 created		0.0.0
2010-11	RAN5#49	R5-106613			V1.0.0 created for presentation to RAN Plenary	0.0.0	1.0.0
2011-02	RAN5#50	R5-110124			Various values and corrections added	1.0.0	1.1.0
2011-08	RAN5#52	R5-113133			Text changes from R5-112139, R5-112386, R5-112837, R5-112838, R5-112839 added	1.1.0	1.2.0
2011-08	RAN5#53				Text changes from R5-113135, R5-113150, R5-114066, R5-113587 added	1.2.0	-

2011-11	RAN#53	R5-115206			Initial draft TS 37.571-1 created from TS 36.571-1, TS 34.171 and TS 34.172	-	1.0.0
2011-11	RAN#53	R5-115207			V2.0.0 created for presentation to RAN Plenary with additions from R5-115246, R5-115247, R5-115248, R5-115809	1.0.0	2.0.0
2011-12	RAN#54	-	-	-	Moved to Rel-9 w with editorial changes only	2.0.0	9.0.0
2012-03	RAN#55	R5-120087	0001	-	Modify OTDOA connection diagrams	9.0.0	9.1.0
2012-03	RAN#55	R5-120089	0002	-	OTDOA parameter corrections	9.0.0	9.1.0
2012-03	RAN#55	R5-120414	0003	-	Adding ECID test cases to Annexes in TS37.571-1	9.0.0	9.1.0
2012-03	RAN#55	R5-120822	0004	-	Correct A-GNSS signalling	9.0.0	9.1.0
2012-03	RAN#55	R5-120823	0005	-	ECID procedure modifications	9.0.0	9.1.0
2012-03	RAN#55	R5-120893	0006	-	OTDOA procedure updates	9.0.0	9.1.0
2012-06	RAN#56	R5-121126	0007	-	Update to Figure 9.1.1.3-1	9.1.0	9.2.0
2012-06	RAN#56	R5-121127	0008	-	Clarification to notes in tests 9.1.3 & 9.1.4	9.1.0	9.2.0
2012-06	RAN#56	R5-121128	0009	-	Clarifications to frequencies and bandwidths to be used	9.1.0	9.2.0
2012-06	RAN#56	R5-121129	0010	-	Setting responseTime in ECID test cases	9.1.0	9.2.0
2012-06	RAN#56	R5-121130	0011	-	Modifications to signalling used in OTDOA test cases	9.1.0	9.2.0
2012-06	RAN#56	R5-121908	0012	-	Adding operating band 26 to TS 37.571-1	9.1.0	9.2.0
2012-06	RAN#56	-	-	-	Added missing contents from R5-121126, R5-121127, R5-121128	9.2.0	9.2.1
2012-06	RAN#56	-	-	-	Upgraded to v10.0.0 with no change.	9.2.1	10.0.0
2012-09	RAN#57	R5-123066	0013	-	Correction to RSTD Measurement Accuracy Tests 9.1.3 and 9.1.4	10.0.0	10.1.0
2012-09	RAN#57	R5-123913	0014	-	Addition of RRM Test Case 9.8.4 TDD inter-frequency RSTD Accuracy	10.0.0	10.1.0
2012-12	RAN#58	R5-125136	0015	-	Corrections to references	10.1.0	10.2.0
2012-12	RAN#58	R5-125188	0016	-	Correction to LPP Message Content for GNSS Moving Scenario Test	10.1.0	10.2.0
2012-12	RAN#58	R5-125806	0018	-	New test case 10.1 FDD RSTD Measurement Reporting Delay for Carrier Aggregation	10.1.0	10.2.0
2012-12	RAN#58	R5-125807	0019	-	New test case 10.2 TDD RSTD Measurement Reporting Delay for Carrier Aggregation	10.1.0	10.2.0
2012-12	RAN#58	R5-125808	0020	-	New test case 10.3 FDD RSTD Measurement Accuracy for Carrier Aggregation	10.1.0	10.2.0
2012-12	RAN#58	R5-125809	0021	-	New test case 10.4 TDD RSTD Measurement Accuracy for Carrier Aggregation	10.1.0	10.2.0
2012-12	RAN#58	R5-125831	0022	-	Adding bands 28 and 44 to TS 37.571-1	10.1.0	10.2.0
2012-12	RAN#58	R5-125847	0023	-	Corrections to procedures for RSTD tests	10.1.0	10.2.0
2012-12	RAN#58	R5-125848	0024	-	Correction of OCN Patterns for UE Rx - Tx Time Difference Test Cases	10.1.0	10.2.0
2012-12	RAN#58	R5-125916	0025	-	Add editor's note for value of lprs for test case 9.1.4	10.1.0	10.2.0
2012-12	RAN#58	R5-124120	0026	-	New common text for test cases 10.1 - 10.4 for RSTD for Carrier Aggregation	10.1.0	10.2.0
2013-03	RAN#59	R5-130959	0027		LBS Perf: Corrections to TCs 8.1.1 and 8.1.2	10.2.0	10.3.0
2013-06	RAN#60	R5-131097	0028	-	Removal of Note 1 from OTDOA parameter tables	10.3.0	10.4.0
2013-06	RAN#60	R5-131176	0029	-	Clarification to RSTD Delay Test procedures	10.3.0	10.4.0
2013-06	RAN#60	R5-131943	0030	-	New Test Case for FDD-FDD inter-frequency RSTD Accuracy	10.3.0	10.4.0
2013-06	RAN#60	R5-131944	0031	-	New Test Case for FDD-FDD inter-frequency RSTD measurement reporting delay	10.3.0	10.4.0
2013-06	RAN#60	R5-131945	0032	-	OTDOA test case alignment with RAN 4	10.3.0	10.4.0
2013-06	RAN#60	R5-131946	0033	-	Corrections to ECID and OTDOA tests Note: same contents as R5-131945 was submitted by accident.	10.3.0	10.4.0
2013-06	RAN#60	R5-131947	0034	-	RSTD test parameter updates	10.3.0	10.4.0
2013-06	RAN#60	R5-131993	0035	-	Test Description for TDD inter-frequency accuracy test case	10.3.0	10.4.0
2013-06	RAN#60	R5-131994	0036	-	New test case for TDD inter-frequency RSTD reporting delay 9.2.2	10.3.0	10.4.0
2013-09	RAN#61	R5-133173	0037	-	Tidy up of Table 9.2.1.4.1-1	10.4.0	10.5.0
2013-09	RAN#61	R5-133174	0038	-	Corrections to ECID and OTDOA tests	10.4.0	10.5.0
2013-09	RAN#61	R5-133375	0039	-	Uncertainties and Test Tolerances for RSTD test cases 9.1.1 and 9.1.2	10.4.0	10.5.0
2013-09	RAN#61	R5-133378	0040	-	Uncertainties and Test Tolerances for RSTD test cases 9.1.3 and 9.1.4	10.4.0	10.5.0
2013-09	RAN#61	R5-133848	0041	-	LBS Perf: Uncertainties and test tolerances for TCs 8.1.1 and 8.1.2	10.4.0	10.5.0
2013-09	RAN#61	R5-133885	0042	-	LBS Perf: Revision of test procedure for TC-s 8.1.1-2	10.4.0	10.5.0