

# 3GPP TS 37.104 V11.6.0 (2013-09)

---

*Technical Specification*

**3rd Generation Partnership Project;  
Technical Specification Group Radio Access Network;  
E-UTRA, UTRA and GSM/EDGE;  
Multi-Standard Radio (MSR) Base Station (BS) radio  
transmission and reception  
(Release 11)**



Keywords

---

LTE, UMTS, GSM, Radio

**3GPP**

Postal address

---

3GPP support office address

---

650 Route des Lucioles - Sophia Antipolis  
Valbonne - FRANCE  
Tel.: +33 4 92 94 42 00 Fax: +33 4 93 65 47 16

Internet

---

<http://www.3gpp.org>

---

**Copyright Notification**

No part may be reproduced except as authorized by written permission.  
The copyright and the foregoing restriction extend to reproduction in all media.

© 2013, 3GPP Organizational Partners (ARIB, ATIS, CCSA, ETSI, TTA, TTC).  
All rights reserved.

UMTS™ is a Trade Mark of ETSI registered for the benefit of its members  
3GPP™ is a Trade Mark of ETSI registered for the benefit of its Members and of the 3GPP Organizational Partners  
LTE™ is a Trade Mark of ETSI currently being registered for the benefit of its Members and of the 3GPP Organizational Partners  
GSM® and the GSM logo are registered and owned by the GSM Association

# Contents

Foreword .....	6
1 Scope .....	7
2 References.....	7
3 Definitions, symbols and abbreviations .....	8
3.1 Definitions .....	8
3.2 Symbols.....	10
3.3 Abbreviations.....	11
4 General.....	13
4.1 Relation between the MSR specification and the single-RAT specifications.....	13
4.2 Relationship between minimum requirements and test requirements .....	13
4.3 Base station classes .....	13
4.4 Regional requirements .....	14
4.5 Operating bands and Band Categories .....	14
4.5.1 Band category 1 aspects (BC1).....	16
4.5.2 Band category 2 aspects (BC2).....	16
4.5.3 Band category 3 aspects (BC3).....	16
4.6 Channel arrangement .....	17
4.6.1 Channel spacing .....	17
4.6.1A CA Channel spacing .....	17
4.6.2 Channel raster .....	17
4.6.3 Carrier frequencies and numbering .....	17
4.7 Requirements for contiguous and non-contiguous spectrum.....	18
4.8 Requirements for BS capable of multi-band operation.....	18
5 Applicability of requirements .....	18
5.1 Band category 1 .....	18
5.2 Band category 2 .....	19
5.3 Band category 3 .....	21
5.4 Inclusion of requirements by reference .....	22
6 Transmitter characteristics .....	22
6.1 General .....	22
6.2 Base station output power.....	22
6.2.1 Minimum requirement.....	23
6.2.2 Additional requirement (regional).....	23
6.2.3 E-UTRA minimum requirement for DL RS power.....	24
6.2.4 UTRA FDD minimum requirement for primary CPICH power .....	24
6.2.5 UTRA TDD minimum requirement for primary CCPCH power .....	24
6.3 Output power dynamics .....	24
6.3.1 E-UTRA minimum requirement.....	24
6.3.2 UTRA FDD minimum requirement .....	24
6.3.3 UTRA TDD minimum requirement.....	24
6.3.4 GSM/EDGE minimum requirement .....	24
6.4 Transmit ON/OFF power .....	24
6.4.1 Transmitter OFF power.....	24
6.4.1.1 Minimum Requirement .....	25
6.4.2 Transmitter transient period .....	25
6.4.2.1 Minimum requirements.....	25
6.5 Transmitted signal quality.....	25
6.5.1 Modulation quality.....	25
6.5.1.1 E-UTRA minimum requirement .....	25
6.5.1.2 UTRA FDD minimum requirement.....	26
6.5.1.3 UTRA TDD minimum requirement .....	26
6.5.1.4 GSM/EDGE minimum requirement .....	26
6.5.2 Frequency error .....	26

6.5.2.1	E-UTRA minimum requirement .....	26
6.5.2.2	UTRA FDD minimum requirement.....	26
6.5.2.3	UTRA TDD minimum requirement .....	26
6.5.2.4	GSM/EDGE minimum requirement .....	26
6.5.3	Time alignment error .....	26
6.5.3.1	E-UTRA minimum Requirement .....	26
6.5.3.2	UTRA FDD minimum requirement.....	27
6.5.3.3	UTRA TDD minimum requirement .....	27
6.6	Unwanted emissions .....	27
6.6.1	Transmitter spurious emissions .....	27
6.6.1.1	Mandatory Requirements .....	28
6.6.1.1.1	Minimum requirement (Category A).....	28
6.6.1.1.2	Minimum requirement (Category B) .....	28
6.6.1.1.3	Additional minimum requirement for BC2 (Category B).....	28
6.6.1.2	Protection of the BS receiver of own or different BS.....	29
6.6.1.2.1	Minimum Requirement .....	29
6.6.1.3	Additional spurious emissions requirements .....	29
6.6.1.3.1	Minimum Requirement .....	29
6.6.1.4	Co-location with other base stations.....	34
6.6.1.4.1	Minimum Requirement .....	34
6.6.2	Operating band unwanted emissions .....	37
6.6.2.1	General minimum requirement for Band Categories 1 and 3 .....	38
6.6.2.2	General minimum requirement for Band Category 2 .....	41
6.6.2.3	GSM/EDGE single-RAT requirements.....	46
6.6.2.4	Additional requirements .....	47
6.6.2.4.1	Limits in FCC Title 47 .....	47
6.6.2.4.2	Unsynchronized operation for BC3 .....	47
6.6.2.4.3	Protection of DTT .....	47
6.6.2.4.4	Co-existence with services in adjacent frequency bands .....	47
6.6.2.4.5	Co-existence with RNSS/GPS services in North America .....	48
6.6.2.4.6	Additional requirements for band 41 .....	48
6.6.3	Occupied bandwidth .....	48
6.6.3.1	Minimum requirement .....	49
6.6.4	Adjacent Channel Leakage power Ratio (ACLR) .....	49
6.6.4.1	E-UTRA minimum requirement .....	49
6.6.4.2	UTRA FDD minimum requirement.....	49
6.6.4.3	UTRA TDD minimum requirement .....	49
6.6.4.4	Cumulative ACLR requirement in non-contiguous spectrum.....	49
6.7	Transmitter intermodulation .....	50
6.7.1	General minimum requirement .....	51
6.7.2	Additional minimum requirement (BC1 and BC2) .....	51
6.7.3	Additional minimum requirement (BC3).....	52
6.7.4	Additional requirements .....	52
7	Receiver characteristics .....	53
7.1	General .....	53
7.2	Reference sensitivity level .....	54
7.2.1	E-UTRA minimum requirement.....	54
7.2.2	UTRA FDD minimum requirement.....	54
7.2.3	UTRA TDD minimum requirement.....	54
7.2.4	GSM/EDGE minimum requirement .....	54
7.3	Dynamic range .....	54
7.3.1	E-UTRA minimum requirement.....	54
7.3.2	UTRA FDD minimum requirement.....	54
7.3.3	UTRA TDD minimum requirement.....	54
7.3.4	GSM/EDGE minimum requirement .....	54
7.4	In-band selectivity and blocking .....	54
7.4.1	General blocking minimum requirement .....	54
7.4.2	General narrowband blocking minimum requirement .....	56
7.4.3	Additional Narrowband blocking minimum requirement for GSM/EDGE .....	57
7.4.4	GSM/EDGE requirements for AM suppression .....	57
7.4.5	Additional BC3 blocking minimum requirement .....	57

7.5	Out-of-band blocking.....	58
7.5.1	General minimum requirement .....	58
7.5.2	Co-location minimum requirement .....	59
7.6	Receiver spurious emissions.....	61
7.6.1	General minimum requirement .....	61
7.6.2	Additional minimum requirement for BC2 (Category B) .....	62
7.7	Receiver intermodulation .....	62
7.7.1	General intermodulation minimum requirement .....	62
7.7.2	General narrowband intermodulation minimum requirement .....	63
7.7.3	Additional narrowband intermodulation minimum requirement for GSM/EDGE .....	65
7.8	In-channel selectivity .....	65
7.8.1	E-UTRA minimum requirement.....	65
8	Performance requirements .....	65
8.1	E-UTRA minimum requirement .....	66
8.2	UTRA FDD minimum requirement .....	66
8.3	UTRA TDD minimum requirement .....	66
8.4	GSM/EDGE minimum requirement.....	66
<b>Annex A (normative): Characteristics of interfering signals .....</b>		<b>67</b>
A.1	UTRA FDD interfering signal.....	67
A.2	UTRA TDD interfering signal.....	67
A.3	E-UTRA interfering signal.....	67
<b>Annex B (normative): Environmental requirements for the BS equipment.....</b>		<b>68</b>
<b>Annex C (informative): Change history.....</b>		<b>69</b>

---

# Foreword

This Technical Specification has been produced by the 3<sup>rd</sup> Generation Partnership Project (3GPP).

The contents of the present document are subject to continuing work within the TSG and may change following formal TSG approval. Should the TSG modify the contents of the present document, it will be re-released by the TSG with an identifying change of release date and an increase in version number as follows:

Version x.y.z

where:

- x the first digit:
  - 1 presented to TSG for information;
  - 2 presented to TSG for approval;
  - 3 or greater indicates TSG approved document under change control.
- y the second digit is incremented for all changes of substance, i.e. technical enhancements, corrections, updates, etc.
- z the third digit is incremented when editorial only changes have been incorporated in the document.

---

# 1 Scope

The present document establishes the minimum RF characteristics of E-UTRA, UTRA and GSM/EDGE Multi-Standard Radio (MSR) Base Station (BS). Requirements for multi-RAT and single-RAT operation of MSR BS are covered in the present document. The requirements in the present document for E-UTRA and UTRA single-RAT operation of MSR BS are also applicable to E-UTRA and UTRA multi-carrier capable single-RAT BS. Requirements for GSM BS that are only single-RAT capable in all supported operating bands are not covered.

---

# 2 References

The following documents contain provisions which, through reference in this text, constitute provisions of the present document.

- References are either specific (identified by date of publication, edition number, version number, etc.) or non-specific.
- For a specific reference, subsequent revisions do not apply.
- For a non-specific reference, the latest version applies. In the case of a reference to a 3GPP document (including a GSM document), a non-specific reference implicitly refers to the latest version of that document *in the same Release as the present document*.

- [1] 3GPP TR 21.905: "Vocabulary for 3GPP Specifications".
- [2] 3GPP TS 25.104, Technical Specification, "3rd Generation Partnership Project; Technical Specification Group Radio Access Network; Base Station (BS) radio transmission and reception (FDD) (Release 9)"
- [3] 3GPP TS 25.105, Technical Specification, "3rd Generation Partnership Project; Technical Specification Group Radio Access Network; Base Station (BS) radio transmission and reception (TDD) (Release 9)"
- [4] 3GPP TS 36.104, Technical Specification, "3rd Generation Partnership Project; Technical Specification Group Radio Access Network; Evolved Universal Terrestrial Radio Access (E-UTRA); Base Station (BS) radio transmission and reception (Release 9)"
- [5] 3GPP TS 45.005, Technical Specification, "3rd Generation Partnership Project; Technical Specification Group GSM/EDGE Radio Access Network; Radio transmission and reception (Release 9)"
- [6] ITU-R Recommendation SM.329-10, "Unwanted emissions in the spurious domain".
- [7] 3GPP TR 25.942, "Technical Report 3rd Generation Partnership Project; Technical Specification Group Radio Access Networks; Radio Frequency (RF) system scenarios (Release 8)"
- [8] "Title 47 of the Code of Federal Regulations (CFR)", Federal Communications Commission.
- [9] ITU-R Recommendation M.1545: "Measurement uncertainty as it applies to test limits for the terrestrial component of International Mobile Telecommunications-2000".
- [10] 3GPP TS 37.141, Technical Specification, "3rd Generation Partnership Project; Technical Specification Group Radio Access Network; E-UTRA, UTRA and GSM/EDGE; Multi-Standard Radio (MSR) Base Station (BS) conformance testing (Release 9)"
- [11] IEC 60721-3-3: "Classification of environmental conditions - Part 3-3: Classification of groups of environmental parameters and their severities - Stationary use at weather protected locations".
- [12] IEC 60721-3-4: "Classification of environmental conditions - Part 3: Classification of groups of environmental parameters and their severities - Section 4: Stationary use at non-weather protected locations".

- [13] ETSI EN 300 019-1-3, *European Standard (Telecommunications series)*, “Environmental Engineering (EE); Environmental conditions and environmental tests for telecommunications equipment; Part 1-3: Classification of environmental conditions; Stationary use at weather protected locations”
- [14] ETSI EN 300 019-1-4, *European Standard (Telecommunications series)*, “Environmental Engineering (EE); Environmental conditions and environmental tests for telecommunications equipment; Part 1-4: Classification of environmental conditions; Stationary use at non-weather protected locations”.

---

## 3 Definitions, symbols and abbreviations

### 3.1 Definitions

For the purposes of the present document, the terms and definitions given in TR 21.905 [1] and the following apply. A term defined in the present document takes precedence over the definition of the same term, if any, in TR 21.905 [1].

**Band category:** A group of operating bands for which the same MSR scenarios apply

**Base Station RF bandwidth:** The bandwidth in which a Base Station transmits and receives multiple carriers and/or RATs simultaneously within a supported operating band

**Base Station RF bandwidth edge:** The frequency of one of the edges of the Base Station RF bandwidth

**Carrier:** The modulated waveform conveying the E-UTRA, UTRA or GSM/EDGE physical channels

**Carrier aggregation:** aggregation of two or more E-UTRA component carriers in order to support wider transmission bandwidths

**Carrier aggregation band:** a set of one or more operating bands across which multiple E-UTRA carriers are aggregated with a specific set of technical requirements.

NOTE: Carrier aggregation band(s) for an E-UTRA BS is declared by the manufacturer according to the designations in Tables 5.5-2 to 5.5-3 of TS 36.104 [4]

**Channel bandwidth:** The bandwidth supporting a single E-UTRA, UTRA or GSM/EDGE RF carrier with the transmission bandwidth configured in the uplink or downlink of a cell. The channel bandwidth is measured in MHz and is used as a reference for transmitter and receiver RF requirements.

**Contiguous carriers:** a set of two or more carriers configured in a spectrum block where there are no RF requirements based on co-existence for un-coordinated operation within the spectrum block.

**Carrier power:** The power at the antenna connector in the channel bandwidth of the carrier averaged over at least one subframe for E-UTRA, at least one slot for UTRA and the useful part of the burst for GSM/EDGE.

**Configured carrier power:** Target maximum power for a specific carrier for the operating mode set in the BS

**Contiguous spectrum:** Spectrum consisting of a contiguous block of spectrum with no sub-block gaps.

**Downlink operating band:** The part of the operating band designated for downlink.

**Inter RF bandwidth gap:** The frequency gap between two consecutive RF bandwidths that are placed within two supported operating bands.

**Inter-band carrier aggregation:** carrier aggregation of E-UTRA component carriers in different operating bands.

NOTE: Carriers aggregated in each band can be contiguous or non-contiguous.

**Intra-band contiguous carrier aggregation:** contiguous E-UTRA carriers aggregated in the same operating band.

**Intra-band non-contiguous carrier aggregation:** non-contiguous E-UTRA carriers aggregated in the same operating band.



**Lower RF bandwidth edge:** The frequency of the lower edge of the Base Station RF bandwidth, used as a frequency reference point for transmitter and receiver requirements.

**Lower sub-block edge:** The frequency at the lower edge of one sub-block. It is used as a frequency reference point for both transmitter and receiver requirements.

**Maximum Base Station RF bandwidth:** The maximum RF bandwidth supported by a BS within each supported operating band.

NOTE: The Maximum Base Station RF bandwidth for BS configured for contiguous and non-contiguous operation within each supported operating band is declared separately.

**Maximum carrier output power:** Carrier power available at the antenna connector for a specified reference condition.

**Maximum RAT output power:** The sum of the power of all carriers of the same RAT available at the antenna connector for a specified reference condition.

**Maximum throughput:** The maximum achievable throughput for a reference measurement channel.

**Maximum total output power:** The sum of the power of all carriers available at the antenna connector for a specified reference condition.

**MB-MSR Base Station:** MSR Base Station characterized by the ability of its transmitter and/or receiver to process two or more carriers in common active RF components simultaneously, where at least one carrier is configured at a different non-overlapping operating band than the other carrier(s).

**Measurement bandwidth:** The bandwidth in which an emission level is specified.

**MSR Base station:** Base Station characterized by the ability of its receiver and transmitter to process two or more carriers in common active RF components simultaneously in a declared RF bandwidth, where at least one carrier is of a different RAT than the other carrier(s).

**Multi-band transmitter:** Transmitter characterized by the ability to process two or more carriers in common active RF components simultaneously, where at least one carrier is configured at a different non-overlapping operating band than the other carrier(s).

**Multi-band receiver:** Receiver characterized by the ability to process two or more carriers in common active RF components simultaneously, where at least one carrier is configured at a different non-overlapping operating band than the other carrier(s).

**Non-contiguous spectrum:** Spectrum consisting of two or more sub-blocks separated by sub-block gap(s).

**Occupied bandwidth:** The width of a frequency band such that, below the lower and above the upper frequency limits, the mean powers emitted are each equal to a specified percentage  $\beta/2$  of the total mean power of a given emission.

**Operating band:** A frequency range in which E-UTRA, UTRA or GSM/EDGE operates (paired or unpaired), that is defined with a specific set of technical requirements.

NOTE: The operating band(s) for a BS is declared by the manufacturer.

**Single-RAT operation:** operation of a BS in an operating band with only one RAT configured in that operating band.

**Sub-block:** This is one contiguous allocated block of spectrum for use by the same Base Station. There may be multiple instances of sub-blocks within an RF bandwidth.

**Sub-block bandwidth:** The bandwidth of one sub-block.

**Sub-block gap:** A frequency gap between two consecutive sub-blocks within an RF bandwidth, where the RF requirements in the gap are based on co-existence for un-coordinated operation.

**Synchronized operation:** Operation of TDD in two different systems, where no simultaneous uplink and downlink occur.

**Throughput:** The number of payload bits successfully received per second for a reference measurement channel in a specified reference condition.

**Transmission bandwidth:** Bandwidth of an instantaneous E-UTRA transmission from a UE or BS, measured in Resource Block units.

**Transmitter ON period:** The time period during which the BS transmitter is transmitting data and/or reference symbols

**Transmitter OFF period:** The time period during which the BS transmitter is not allowed to transmit

**Transmitter transient period:** The time period during which the transmitter is changing from the OFF period to the ON period or vice versa

**Unsynchronized operation:** Operation of TDD in two different systems, where the conditions for synchronized operation are not met.

**Uplink operating band:** The part of the operating band designated for uplink.

**Upper RF bandwidth edge:** The frequency of the upper edge of the Base Station RF bandwidth, used as a frequency reference point for transmitter and receiver requirements

**Upper sub-block edge:** The frequency at the upper edge of one sub-block. It is used as a frequency reference point for both transmitter and receiver requirements.

## 3.2 Symbols

For the purposes of the present document, the following symbols apply:

$\beta$	Percentage of the mean transmitted power emitted outside the occupied bandwidth on the assigned channel
$BW_{\text{Channel}}$	Channel bandwidth (for E-UTRA)
$BW_{\text{RF}}$	Base Station RF bandwidth, where $BW_{\text{RF}} = F_{\text{BW RF,high}} - F_{\text{BW RF,low}}$
$BW_{\text{RF,max}}$	Maximum Base Station RF bandwidth
$DwPTS$	Downlink part of the special subframe (for E-UTRA TDD operation)
$f$	Frequency
$\Delta f$	Separation between the Base Station RF bandwidth edge frequency and the nominal -3dB point of the measuring filter closest to the carrier frequency
$\Delta f_{\text{max}}$	The largest value of $\Delta f$ used for defining the requirement
$F_C$	Carrier centre frequency
$F_{\text{filter}}$	Filter centre frequency
$f_{\text{offset}}$	Separation between the Base Station RF bandwidth edge frequency and the centre of the measuring filter
$f_{\text{offset,max}}$	The maximum value of $f_{\text{offset}}$ used for defining the requirement
$F_{\text{block,high}}$	Upper sub-block edge, where $F_{\text{block,high}} = F_{\text{C,block,high}} + F_{\text{offset,RAT}}$
$F_{\text{block,low}}$	Lower sub-block edge, where $F_{\text{block,low}} = F_{\text{C,block,low}} - F_{\text{offset,RAT}}$
$F_{\text{BW RF,high}}$	Upper RF bandwidth edge, where $F_{\text{BW RF,high}} = F_{\text{C,high}} + F_{\text{offset,RAT}}$
$F_{\text{BW RF,low}}$	Lower RF bandwidth edge, where $F_{\text{BW RF,low}} = F_{\text{C,low}} - F_{\text{offset,RAT}}$
$F_{\text{C,block,high}}$	Center frequency of the highest transmitted/received carrier in a sub-block.
$F_{\text{C,block,low}}$	Center frequency of the lowest transmitted/received carrier in a sub-block.
$F_{\text{C,high}}$	Center frequency of the highest transmitted/received carrier.
$F_{\text{C,low}}$	Center frequency of the lowest transmitted/received carrier.
$F_{\text{offset,RAT}}$	Frequency offset from the centre frequency of the <i>highest</i> transmitted/received carrier to the <i>upper</i> RF bandwidth edge or sub-block edge, or from the centre frequency of the <i>lowest</i> transmitted/received to the <i>lower</i> RF bandwidth edge or sub-block edge for a specific RAT.
$F_{\text{DL,low}}$	The lowest frequency of the downlink operating band
$F_{\text{DL,high}}$	The highest frequency of the downlink operating band
$F_{\text{UL,low}}$	The lowest frequency of the uplink operating band
$F_{\text{UL,high}}$	The highest frequency of the uplink operating band
$P_{\text{EM,N}}$	Declared emission level for channel N
$P_{\text{max}}$	Maximum total output power
$P_{\text{max,RAT}}$	Maximum RAT output power
$P_{\text{max,c}}$	Maximum carrier output power
$P_{\text{Rated,c}}$	Rated carrier output power
$P_{\text{REFSENS}}$	Reference Sensitivity power level

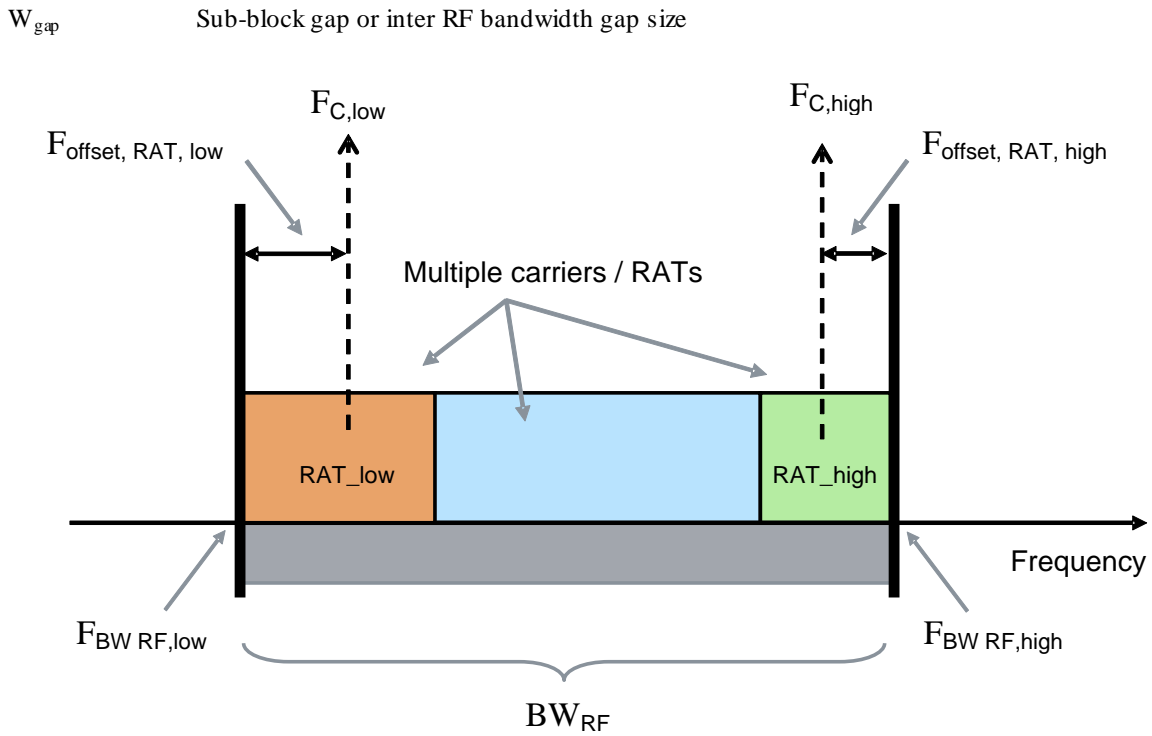

Figure 3.2-1: Illustration of RF bandwidth related symbols and definitions for Multi-standard Radio.

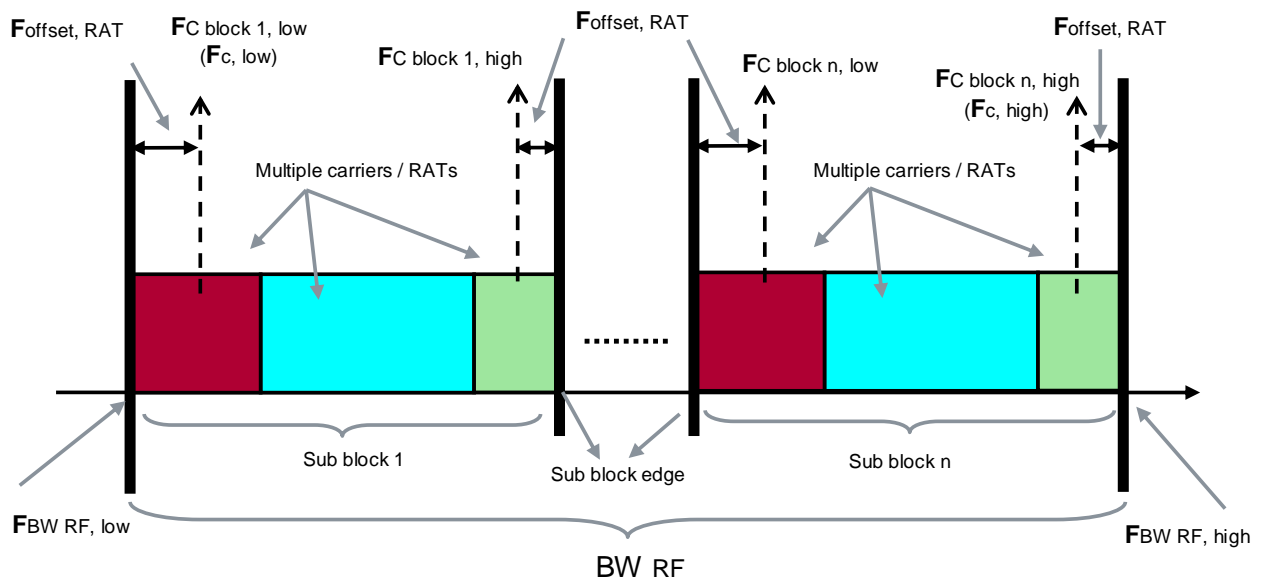

Figure 3.2-2: Illustration of RF bandwidth related symbols and definitions for non-contiguous Multi-standard Radio or Multi-band Multi-standard Radio in one supported operating band.

### 3.3 Abbreviations

For the purposes of the present document, the abbreviations given in TR 21.905 [1] and the following apply. An abbreviation defined in the present document takes precedence over the definition of the same abbreviation, if any, in TR 21.905 [1].

ACLR            Adjacent Channel Leakage Ratio

ACS	Adjacent Channel Selectivity
ARFCN	Absolute Radio Frequency Channel Number
AWGN	Additive White Gaussian Noise
BC	Band Category
BER	Bit Error Ratio
BS	Base Station
BTS	Base Transceiver Station
CA	Carrier Aggregation
CACLR	Cumulative Adjacent Channel Leakage Ratio
CP	Cyclic prefix
CW	Continuous Wave
DB-DC-HSDPA	Dual Band Dual Cell HSDPA
DC-HSDPA	Dual Cell HSDPA
DC-HSUPA	Dual Cell HSUPA
DTT	Digital Terrestrial Television
EARFCN	E-UTRA Absolute Radio Frequency Channel Number
EDGE	Enhanced Data rates for GSM Evolution
EIRP	Effective Isotropic Radiated Power
EVM	Error Vector Magnitude
FCC	Federal Communications Commission
FDD	Frequency Division Duplex
FRC	Fixed Reference Channel
GP	Guard Period (for E-UTRA TDD operation)
GSM	Global System for Mobile Communications
HSDPA	High Speed Downlink Packet Access
HSUPA	High Speed Uplink Packet Access
ICS	In-Channel Selectivity
ITU-R	Radiocommunication Sector of the ITU
LA	Local Area
LNA	Low Noise Amplifier
MB-MSR	Multi-Band Multi-Standard Radio
MIMO	Multiple Input Multiple Output
MR	Medium Range
MS	Mobile Station
MSR	Multi-Standard Radio
PA	Power Amplifier
PHS	Personal Handyphone System
QPSK	Quadrature Phase-Shift Keying
RAT	Radio Access Technology
RB	Resource Block (for E-UTRA)
RF	Radio Frequency
RMS	Root Mean Square (value)
RS	Reference Symbol
RX	Receiver
SNR	Signal-to-Noise Ratio
TDD	Time Division Duplex
TX	Transmitter
UARFCN	UTRA Absolute Radio Frequency Channel Number
UE	User Equipment
UEM	operating band Unwanted Emissions Mask
WA	Wide Area

---

## 4 General

### 4.1 Relation between the MSR specification and the single-RAT specifications

The requirements for MSR are in most parts specified in the present document, while many requirements are also specified through normative references to the respective single-RAT specifications in [2], [3], [4] and [5]. The resulting set of requirements for an MSR BS can be divided into three types, depending on their relation to the single-RAT specifications:

1. **Generic MSR requirement:** A common generic requirement is specified in the present document that applies for all RATs and for BS configured for both multi-RAT and single-RAT operation. In some cases, there are additional requirement(s) that apply only in some Band Category. There are no references to the single-RAT specifications.
2. **Generic MSR requirement, with additional single-RAT requirements:** A common generic requirement is specified in the present document which applies as in point 1. In addition some single RAT requirement(s) apply, included by normative reference(s) to the single-RAT specification(s).
3. **Single-RAT only requirements:** In this case, no common generic requirement is defined. The existing single-RAT requirement applies for each RAT, included by normative reference(s) to the single-RAT specification(s).

The applicability of each requirement is described in clause 5.

### 4.2 Relationship between minimum requirements and test requirements

The Minimum Requirements given in this specification make no allowance for measurement uncertainty. The test specification TS 37.141 [10] defines Test Tolerances. These Test Tolerances are individually calculated for each test. The Test Tolerances are used to relax the Minimum Requirements in this specification to create Test Requirements. For some requirements, including regulatory requirements, the test tolerance is set to zero.

For MSR single-RAT requirements, the principle used to define the test requirement remains from the existing specifications.

For both MSR single-RAT and multi-RAT requirements, the measurement results returned by the Test System are compared - without any modification - against the Test Requirements as defined by the shared risk principle. The Shared Risk principle is defined in ITU-R M.1545 [9].

### 4.3 Base station classes

The requirements in this specification apply to Wide Area Base Stations, Medium Range Base Stations and Local Area Base Stations unless otherwise stated.

Wide Area Base Stations are characterised by requirements derived from Macro Cell scenarios with a BS to UE minimum coupling loss equal to 70 dB. The Wide Area Base Station class has the same requirements as the base station for General Purpose application in Release 9 and 10.

Medium Range Base Stations are characterised by requirements derived from Micro Cell scenarios with a BS to UE minimum coupling loss equals to 53 dB.

Local Area Base Stations are characterised by requirements derived from Pico Cell scenarios with a BS to UE minimum coupling loss equal to 45 dB.

For GSM/EDGE operation of an MSR BS, the requirements according to the applicable multicarrier BTS class apply. The Wide Area BS, Medium Range BS and Local Area BS in the present specification correspond to the Wide Area multicarrier BTS, Medium Range multicarrier BTS and Local Area multicarrier BTS respectively in the GSM/EDGE specifications. MSR requirements for multi-RAT operation only apply for the highest GSM/EDGE static power step.

## 4.4 Regional requirements

Some requirements in the present document may only apply in certain regions either as optional requirements, or set by local and regional regulation as mandatory requirements. It is normally not stated in the 3GPP specifications under what exact circumstances that the requirements apply, since this is defined by local or regional regulation.

Table 4.4-1 lists all requirements in the present specification that may be applied differently in different regions. There are additional single-RAT regional requirements that may apply. These are referenced from the present specification, but listed in the specification for the RATs concerned [2][3][4][5].

**Table 4.4-1: List of regional requirements**

Clause number	Requirement	Comments
4.5	Operating bands and Band Categories	Some bands may be applied regionally.
6.2.2	Base station output power	These requirements apply in Japan for an E-UTRA BS operating in band 34 and Band 41.
6.6.1.1	Mandatory requirements (spurious emissions)	Category A limits are mandatory for regions where Category A limits for spurious emissions, as defined in ITU-R Recommendation SM.329 [2] apply. Category B limits are mandatory for regions where Category B limits for spurious emissions, as defined in ITU-R Recommendation SM.329 [2] apply.
6.6.1.3	Additional spurious emissions requirements	These requirements may be applied for the protection of system operating in frequency ranges other than the MSR BS operating band.
6.6.1.3	Additional spurious emissions requirements	In addition to the requirements in subclauses 6.6.1.1, 6.6.1.2 and 6.6.1.3, the BS may have to comply with the applicable emission limits established by FCC Title 47 [8], when deployed in regions where those limits are applied, and under the conditions declared by the manufacturer.
6.6.1.4	Co-location (spurious emissions)	These requirements may be applied for the protection of other BS receivers when a BS operating in another frequency band is co-located with an MSR BS.
6.6.2.4.1	Additional requirement (Operating band unwanted emissions)	In addition to the requirements in subclauses 6.6.2.1 and 6.6.2.2, the BS may have to comply with the applicable emission limits established by FCC Title 47 [8], when deployed in regions where those limits are applied and under the conditions declared by the manufacturer.
6.6.2.4.2	Unsynchronized operation for BC3 (Operating band unwanted emissions)	The requirements for unsynchronized TDD co-existence may apply regionally.
6.6.2.4.3	Protection of DTT (Operating band unwanted emissions)	The requirements for protection of DTT may apply regionally.
6.6.2.4.4	Co-existence with services in adjacent frequency bands (Operating band unwanted emissions)	This regional requirement may be applied for the protection of systems operating in frequency bands adjacent to band 1 as defined in clause 4.5, in geographic areas in which both an adjacent band service and UTRA and/or E-UTRA are deployed.
6.6.2.4.6	Additional requirements for band 41 (Operating band unwanted emissions)	These requirements may apply in certain regions as additional Operating band unwanted emission limits.
6.6.3	Occupied bandwidth	The requirement may be applied regionally. There may also be regional requirements to declare the Occupied bandwidth according to the definition.
6.7.4	Additional requirements	These requirements may apply in certain regions.
7.5.2	Co-location requirement (blocking)	These requirements may be applied for the protection of the BS receiver when a BS operating in another frequency band is co-located with an MSR BS.

## 4.5 Operating bands and Band Categories

MSR requirements are applicable for band definitions and band numbering as defined in the specifications TS 45.005 [5], TS25.104 [2], TS 25.105 [3] and TS 36.104 [4]. For the purpose of defining the BS requirements, the operating bands are divided into three band categories as follows:

- Band Category 1 (BC1): Bands for E-UTRA FDD and UTRA FDD operation

- Band Category 2 (BC2): Bands for E-UTRA FDD, UTRA FDD and GSM/EDGE operation
- Band Category 3 (BC3): Bands for E-UTRA TDD and UTRA TDD operation

NOTE: For UTRA TDD, requirements in the present document cover the 1.28 Mcps UTRA TDD option.

The paired and unpaired bands for the three Band Categories are shown in Table 4.5-1 and 4.5-2, together with the corresponding E-UTRA, UTRA and GSM/EDGE band designations. In the present specification, the operating band of an MSR Base Stations is designated using the E-UTRA band number according to the tables.

**Table 4.5-1: Paired bands in E-UTRA, UTRA and GSM/EDGE.**

MSR and E-UTRA Band number	UTRA Band number	GSM/EDGE Band designation	Uplink (UL) BS receive UE transmit	Downlink (DL) BS transmit UE receive	Band category
1	I	-	1920 MHz – 1980 MHz	2110 MHz – 2170 MHz	1
2	II	PCS 1900	1850 MHz – 1910 MHz	1930 MHz – 1990 MHz	2
3	III	DCS 1800	1710 MHz – 1785 MHz	1805 MHz – 1880 MHz	2
4	IV	-	1710 MHz – 1755 MHz	2110 MHz – 2155 MHz	1
5	V	GSM 850	824 MHz – 849 MHz	869 MHz – 894MHz	2
6 <sup>(1)</sup>	VI	-	830 MHz – 840 MHz	875 MHz – 885 MHz	1 <sup>(1)</sup>
7	VII	-	2500 MHz – 2570 MHz	2620 MHz – 2690 MHz	1
8	VIII	E-GSM	880 MHz – 915 MHz	925 MHz – 960 MHz	2
9	IX	-	1749.9 MHz – 1784.9 MHz	1844.9 MHz – 1879.9 MHz	1
10	X	-	1710 MHz – 1770 MHz	2110 MHz – 2170 MHz	1
11	XI	-	1427.9 MHz – 1447.9 MHz	1475.9 MHz – 1495.9 MHz	1
12	XII	-	699 MHz – 716 MHz	729 MHz – 746 MHz	1
13	XIII	-	777 MHz – 787 MHz	746 MHz – 756 MHz	1
14	XIV	-	788 MHz – 798 MHz	758 MHz – 768 MHz	1
15	XV	-	Reserved	Reserved	
16	XVI	-	Reserved	Reserved	
17	-	-	704 MHz – 716 MHz	734 MHz – 746 MHz	1 <sup>(2)</sup>
18	-	-	815 MHz – 830 MHz	860 MHz – 875 MHz	1 <sup>(2)</sup>
19	XIX	-	830 MHz – 845 MHz	875 MHz – 890 MHz	1
20	XX	-	832 MHz – 862 MHz	791 MHz – 821 MHz	1
21	XXI	-	1447.9 MHz – 1462.9 MHz	1495.9 MHz – 1510.9 MHz	1
22	XXII	-	3410 MHz – 3490 MHz	3510 MHz – 3590 MHz	1
23	-	-	2000 MHz – 2020 MHz	2180 MHz – 2200 MHz	1 <sup>(2)</sup>
24	-	-	1626.5 MHz – 1660.5 MHz	1525 MHz – 1559 MHz	1 <sup>(2)</sup>
25	XXV	-	1850 MHz – 1915 MHz	1930 MHz – 1995 MHz	1
26	XXVI	-	814 MHz – 849 MHz	859 MHz – 894 MHz	1
27	-	-	807 MHz – 824 MHz	852 MHz – 869 MHz	1 <sup>(2)</sup>
28	-	-	703 MHz – 748 MHz	758 MHz – 803 MHz	1 <sup>(2)</sup>
29	-	-	N/A	717 MHz – 728 MHz	FDD <sup>3</sup>

NOTE 1: The band is for UTRA only.  
NOTE 2: The band is for E-UTRA only.  
NOTE 3: Restricted to E-UTRA operation when carrier aggregation is configured. The downlink operating band is paired with the uplink operating band (external) of the carrier aggregation configuration that is supporting the configured Pcell.

UTRA FDD can operate with DB-DC-HSDPA for the band configurations listed in subclause 5.2 c) of TS 25.104 [2].

NOTE: For BS capable of multi-band operation, the supported operating bands may belong to different Band Categories.

Table 4.5-2: Unpaired bands in E-UTRA and UTRA.

MSR and E-UTRA Band number	UTRA Band number	Uplink (UL) BS receive UE transmit	Downlink (DL) BS transmit UE receive	Band category
33	a)	1900 MHz – 1920 MHz	1900 MHz – 1920 MHz	3
34	a)	2010 MHz – 2025 MHz	2010 MHz – 2025 MHz	3
35	b)	1850 MHz – 1910 MHz	1850 MHz – 1910 MHz	3
36	b)	1930 MHz – 1990 MHz	1930 MHz – 1990 MHz	3
37	c)	1910 MHz – 1930 MHz	1910 MHz – 1930 MHz	3
38	d)	2570 MHz – 2620 MHz	2570 MHz – 2620 MHz	3
39	f)	1880 MHz – 1920 MHz	1880 MHz – 1920 MHz	3
40	e)	2300 MHz – 2400 MHz	2300 MHz – 2400 MHz	3
41	-	2496 MHz – 2690 MHz	2496 MHz – 2690 MHz	3
42	-	3400 MHz – 3600 MHz	3400 MHz – 3600 MHz	3
43	-	3600 MHz – 3800 MHz	3600 MHz – 3800 MHz	3
44	-	703 MHz – 803 MHz	703 MHz – 803 MHz	3

E-UTRA is designed to operate for the carrier aggregation bands defined in Tables 5.5-2, 5.5-3 and 5.5.4 of TS 36.104 [4]. The E-UTRA channel bandwidth  $BW_{\text{Channel}}$  for a single carrier and the Aggregated Channel Bandwidth  $BW_{\text{Channel\_CA}}$  for E-UTRA carrier aggregation are specified in Section 5.6 of TS 36.104 [4].

#### 4.5.1 Band category 1 aspects (BC1)

BC1 requirements for receiver and transmitter shall apply with a frequency offset from the lowest and highest carriers to the RF bandwidth edges ( $F_{\text{offset, RAT}}$ ) as defined in Table 4.5.1-1.

Table 4.5.1-1:  $F_{\text{offset, RAT}}$  for Band Category 1

RAT	$F_{\text{offset, RAT}}$
1.4, 3 MHz E-UTRA	$BW_{\text{Channel}}/2 + 200 \text{ kHz}$
5, 10, 15, 20 MHz E-UTRA	$BW_{\text{Channel}}/2$
UTRA FDD	2.5 MHz

#### 4.5.2 Band category 2 aspects (BC2)

BC2 requirements for receiver and transmitter shall apply with a frequency offset from the lowest and highest carriers to the RF bandwidth edges ( $F_{\text{offset, RAT}}$ ) as defined in Table 4.5.2-1.

Table 4.5.2-1:  $F_{\text{offset, RAT}}$  for Band Category 2

RAT	$F_{\text{offset, RAT}}$
E-UTRA	$BW_{\text{Channel}}/2$
UTRA FDD	2.5 MHz
GSM/EDGE	200 kHz

#### 4.5.3 Band category 3 aspects (BC3)

BC3 requirements for receiver and transmitter shall apply with a frequency offset from the lowest and highest carriers to the RF bandwidth edges ( $F_{\text{offset, RAT}}$ ) as defined in Table 4.5.3-1.

Table 4.5.3-1:  $F_{\text{offset, RAT}}$  for Band Category 3

RAT	$F_{\text{offset, RAT}}$
1.4, 3 MHz E-UTRA	$BW_{\text{Channel}}/2 + 200 \text{ kHz}$
5, 10, 15, 20 MHz E-UTRA	$BW_{\text{Channel}}/2$
1.28 Mcps UTRA TDD	1 MHz



## 4.6 Channel arrangement

### 4.6.1 Channel spacing

The GSM/EDGE carrier spacing is 200 kHz [5].

The nominal UTRA FDD channel spacing is 5 MHz. The nominal channel spacing is 1.6MHz for the 1.28 Mcps UTRA TDD Option. These can be adjusted to optimise performance in a particular deployment scenario [2,3].

In E-UTRA the spacing between carriers will depend on the deployment scenario, the size of the frequency block available and the channel bandwidths. The nominal channel spacing between two adjacent E-UTRA carriers is defined as following:

$$\text{Nominal Channel spacing} = (BW_{\text{Channel}(1)} + BW_{\text{Channel}(2)})/2$$

where  $BW_{\text{Channel}(1)}$  and  $BW_{\text{Channel}(2)}$  are the channel bandwidths of the two respective E-UTRA carriers. The channel spacing can be adjusted to optimize performance in a particular deployment scenario [4].

#### 4.6.1A CA Channel spacing

For contiguously aggregated carriers the channel spacing between adjacent component carriers shall be multiple of 300 kHz.

The nominal channel spacing between two adjacent aggregated E-UTRA carriers is defined as follows:

$$\text{Nominal channel spacing} = \left\lfloor \frac{BW_{\text{Channel}(1)} + BW_{\text{Channel}(2)} - 0.1|BW_{\text{Channel}(1)} - BW_{\text{Channel}(2)}|}{0.6} \right\rfloor 0.3$$

where  $BW_{\text{Channel}(1)}$  and  $BW_{\text{Channel}(2)}$  are the channel bandwidths of the two respective E-UTRA component carriers according to Table 5.6-1 with values in MHz. The channel spacing for intra-band contiguous carrier aggregation can be adjusted to any multiple of 300 kHz less than the nominal channel spacing to optimize performance in a particular deployment scenario.

### 4.6.2 Channel raster

The GSM/EDGE channel raster is 200 kHz for all bands [5].

The UTRA FDD and TDD channel raster is 200 kHz for all bands, which means that the centre frequency must be an integer multiple of 200 kHz. In addition a number of additional centre frequencies are specified for UTRA FDD according to [2], which means that the centre frequencies for UTRA FDD channels are shifted 100 kHz relative to the general raster.

The E-UTRA channel raster is 100 kHz for all bands, which means that the carrier centre frequency must be an integer multiple of 100 kHz [4].

### 4.6.3 Carrier frequencies and numbering

The carrier frequencies and corresponding numbering is defined for each RAT in the respective specifications TS 36.104 [4] TS25.104 [2], TS 25.105 [3] and TS 45.005 [5]. In the context of MSR, the frequency numbering scheme for each RAT will remain.

- The E-UTRA carrier frequency numbering (EARFCN) is defined in subclause 5.7 of TS 36.104 [4].
- The UTRA FDD carrier frequency numbering (UARFCN) is defined in subclause 5.4 of TS 25.104 [2].
- The UTRA TDD carrier frequency numbering (UARFCN) is defined in subclause 5.4 of TS 25.105 [3].
- The GSM/EDGE carrier frequency numbering (ARFCN) is defined subclause 2 of TS 45.005 [5].

NOTE: The numbering schemes for UTRA FDD and TDD are not coordinated, while both are called UARFCN.

## 4.7 Requirements for contiguous and non-contiguous spectrum

A spectrum allocation where an MSR BS operates can either be contiguous or non-contiguous. Unless otherwise stated, the requirements in the present specification apply for BS configured for both contiguous spectrum operation and non-contiguous spectrum operation.

For MSR BS operation in non-contiguous spectrum, some requirements apply both at the RF bandwidth edges and inside the sub-block gaps. For each such requirement, it is stated how the limits apply relative to the RF bandwidth edges and the sub-block edges respectively.

## 4.8 Requirements for BS capable of multi-band operation

For BS capable of multi-band operation, the RF requirements in clause 6 and 7 apply for each supported operating band unless otherwise stated. For some requirements it is explicitly stated that specific additions or exclusions to the requirement apply for BS capable of multi-band operation. In the case of multiband operation of a BS, single-RAT operation and the corresponding applicability of the requirements for each operating band is determined based on the RAT configuration within only that operating band, unless otherwise stated.

For BS capable of multi-band operation, various structures in terms of combinations of different transmitter and receiver implementations (multi-band or single band) with mapping of transceivers to one or more antenna port(s) in different ways are possible. In the case where multiple bands are mapped on separate antenna connectors, the following applies:

- Single-band transmitter spurious emissions, operating band unwanted emissions, ACLR, transmitter intermodulation and receiver spurious emissions requirements apply to each antenna connector.
- If the BS is configured for single-band operation, single-band requirements shall apply to the antenna connector configured for single-band operation and no exclusions or provisions for multi-band capable BS are applicable. Single-band requirements are tested separately at the antenna connector configured for single-band operation, with all other antenna connectors terminated.

For a BS capable of multi-band operation supporting BC3 bands for TDD, the RF requirements in the present specification assume synchronized operation, where no simultaneous uplink and downlink occur between the bands.

---

# 5 Applicability of requirements

## 5.1 Band category 1

For all BS operating in bands belonging to Band Category 1, the RF requirements listed in Table 5.1-1 apply for each supported operating band. Requirements apply according to the RAT configuration of the Base Station, as listed in the heading of the table. Some requirements listed in the table may not be mandatory or they may apply only regionally. This is further specified in the clause of each requirement and in Table 4.4-1. For multiband operation, the applicability of the requirements for each operating band is determined based on the RAT configuration within only that operating band, unless otherwise stated.

**Table 5.1-1: Applicability of requirements for MSR BS operation in Band Category 1**

RF requirement	BS configured for multi-RAT operation in the band	BS configured for single-RAT E-UTRA FDD operation in the band	BS configured for single-RAT UTRA FDD operation in the band
Base station output power	6.2.1 6.2.3 6.2.4	6.2.1  6.2.3	6.2.1 6.2.4
Output power dynamics	6.3.1 6.3.2	6.3.1	6.3.2
Transmitted signal quality			
Modulation quality	6.5.1.1 6.5.1.2	6.5.1.1	6.5.1.2
Frequency error	6.5.2.1 6.5.2.2	6.5.2.1	6.5.2.2
Time alignment error	6.5.3.1 6.5.3.2	6.5.3.1	6.5.3.2
Unwanted emissions			
Transmitter spurious emissions	6.6.1 (except for 6.6.1.1.3)	6.6.1 (except for 6.6.1.1.3)	6.6.1 (except for 6.6.1.1.3)
Operating band unwanted emissions	6.6.2.1 6.6.2.4	6.6.2.1 6.6.2.4	6.6.2.1 6.6.2.4
Occupied bandwidth	6.6.3	6.6.3	6.6.3
ACLR	6.6.4.1 6.6.4.2	6.6.4.1	6.6.4.2
Cumulative ACLR	6.6.4.4 (NOTE 3)	6.6.4.4 (NOTE 3)	6.6.4.4 (NOTE 3)
Transmitter intermodulation	6.7.1 6.7.2 (NOTE 2)	6.7.1 6.7.2 (NOTE 2)	6.7.1 6.7.2 (NOTE 2)
Reference sensitivity level	7.2.1 7.2.2	7.2.1	7.2.2
Dynamic range	7.3.1 7.3.2	7.3.1	7.3.2
In-band selectivity and blocking			
Blocking	7.4.1	7.4.1	7.4.1
Narrowband blocking	7.4.2	7.4.2	7.4.2
Out-of-band blocking	7.5	7.5	7.5
Receiver spurious emissions	7.6.1	7.6.1	7.6.1
Receiver intermodulation			
Intermodulation	7.7.1	7.7.1	7.7.1
Narrowband intermodulation	7.7.2	7.7.2	7.7.2
In-channel selectivity	7.8	7.8	-
Performance requirements	8.1 8.2	8.1	8.2
NOTE 1: For some requirements in BS configured for multi-RAT operation, there is no general MSR multi-RAT requirement. Instead, the requirement is defined by the respective single-RAT requirement for each RAT supported by the BS as referenced in the table.			
NOTE 2: The requirement in sub-clause 6.7.2 is only applied for BS operating in non-contiguous spectrum.			
NOTE 3: The requirement in sub-clause 6.6.4.4 is only applied for BS operating in non-contiguous spectrum.			

## 5.2 Band category 2

For all BS operating in bands belonging to Band Category 2, the RF requirements listed in Table 5.2-1 apply for each supported operating band. Requirements apply according to the RAT configuration of the Base Station, as listed in the heading of the table. Some requirements listed in the table may not be mandatory or they may apply only regionally. This is further specified in the clause of each requirement and in Table 4.4-1. For multiband operation, the applicability of the requirements for each operating band is determined based on the RAT configuration within only that operating band, unless otherwise stated.

Table 5.2-1: Applicability of requirements for MSR BS operation in Band Category 2

RF requirement	BS configured for multi-RAT operation not including GSM/EDGE in the band	BS configured for multi-RAT operation including GSM/EDGE in the band	BS configured for single-RAT E-UTRA FDD operation in the band	BS configured for single-RAT UTRA FDD operation in the band	BS configured for single-RAT GSM/EDGE operation in the band
Base station output power	6.2.1 6.2.3 6.2.4	6.2.1 6.2.3 6.2.4	6.2.1 6.2.3	6.2.1 6.2.4	6.2.1
Output power dynamics	6.3.1 6.3.2	6.3.1 6.3.2 6.3.4	6.3.1	6.3.2	6.3.4
Transmit ON/OFF power	-	-	-	-	-
Transmitted signal quality					
Modulation quality	6.5.1.1 6.5.1.2	6.5.1.1 6.5.1.2 6.5.1.4	6.5.1.1	6.5.1.2	6.5.1.4
Frequency error	6.5.2.1 6.5.2.2	6.5.2.1 6.5.2.2 6.5.2.4	6.5.2.1	6.5.2.2	6.5.2.4
Time alignment error	6.5.3.1 6.5.3.2	6.5.3.1 6.5.3.2	6.5.3.1	6.5.3.2	-
Unwanted emissions					
Transmitter spurious emissions	6.6.1 (except for 6.6.1.1.3)	6.6.1 (NOTE 3)	6.6.1 (except for 6.6.1.1.3)	6.6.1 (except for 6.6.1.1.3)	6.6.1 (NOTE 3)
Operating band unwanted emissions	6.6.2.2 6.6.2.4	6.6.2.2 6.6.2.4	6.6.2.2 6.6.2.4	6.6.2.2 6.6.2.4	6.6.2.3 6.6.2.4
Occupied bandwidth	6.6.3	6.6.3	6.6.3	6.6.3	-
ACLR	6.6.4.1 6.6.4.2	6.6.4.1 6.6.4.2	6.6.4.1	6.6.4.2	-
Cumulative ACLR	6.6.4.4 (NOTE 2)	6.6.4.4 (NOTE 2)	6.6.4.4 (NOTE 2)	6.6.4.4 (NOTE 2)	-
Transmitter intermodulation	6.7.1 6.7.2	6.7.1 6.7.2	6.7.1 6.7.2	6.7.1 6.7.2	6.7.2
Reference sensitivity level	7.2.1 7.2.2	7.2.1 7.2.2 7.2.4	7.2.1	7.2.2	7.2.4
Dynamic range	7.3.1 7.3.2	7.3.1 7.3.2 7.3.4	7.3.1	7.3.2	7.3.4
In-band selectivity and blocking					
Blocking	7.4.1	7.4.1	7.4.1	7.4.1	7.4.1
Narrowband blocking	7.4.2	7.4.2 7.4.3	7.4.2	7.4.2	7.4.2 7.4.3 7.4.4
Out-of-band blocking	7.5	7.5	7.5	7.5	7.5
Receiver spurious emissions	7.6.1	7.6.1 7.6.2 (NOTE 3)	7.6.1	7.6.1	7.6.1 7.6.2 (NOTE 3)
Receiver intermodulation					
Intermodulation	7.7.1	7.7.1	7.7.1	7.7.1	7.7.1
Narrowband intermodulation	7.7.2	7.7.2 7.7.3	7.7.2	7.7.2	7.7.2 7.7.3
In-channel selectivity	7.8	7.8	7.8	-	-
Performance requirements	8.1 8.2	8.1 8.2 8.4	8.1	8.2	8.4
NOTE 1: For some requirements in BS configured for multi-RAT operation, there is no general MSR multi-RAT requirement. Instead, the requirement is defined by the respective single-RAT requirement for each RAT supported by the BS as referenced in the table.					
NOTE 2: The requirement in sub-clause 6.6.4.4 is only applied for BS operating in non-contiguous spectrum.					
NOTE 3: For BS capable of multi-band operation, the limits in subclause 6.6.1.1.3 and 7.6.2 are only applicable when all supported operating bands belong to BC2 and GSM/EDGE is configured in all operating bands.					

## 5.3 Band category 3

For all BS operating in bands belonging to Band Category 3, the RF requirements listed in Table 5.3-1 apply for each supported operating band. Requirements apply according to the RAT configuration of the Base Station, as listed in the heading of the table. Some requirements listed in the table may not be mandatory or they may apply only regionally. This is further specified in the clause of each requirement and in Table 4.4-1.

**Table 5.3-1: Applicability of requirements for MSR BS operation in Band Category 3**

RF requirement	BS configured for multi-RAT operation	BS configured for single-RAT E-UTRA TDD operation	BS configured for single-RAT UTRA TDD operation
Base station output power	6.2.1	6.2.1	6.2.1
	6.2.2	6.2.2	6.2.5
	6.2.3	6.2.3	
	6.2.5		
Output power dynamics	6.3.1	6.3.1	6.3.3
	6.3.3		
Transmit ON/OFF power	6.4	6.4	6.4
Transmitted signal quality			
Modulation quality	6.5.1.1 6.5.1.3	6.5.1.1	6.5.1.3
Frequency error	6.5.2.1 6.5.2.3	6.5.2.1	6.5.2.3
Time alignment error	6.5.3.1 6.5.3.3	6.5.3.1	6.5.3.3
Unwanted emissions			
Transmitter spurious emissions	6.6.1 (except for 6.6.1.1.3 and 6.6.1.2)	6.6.1 (except for 6.6.1.1.3 and 6.6.1.2)	6.6.1 (except for 6.6.1.1.3 and 6.6.1.2)
Operating band unwanted emissions	6.6.2.1	6.6.2.1	6.6.2.1
	6.6.2.4	6.6.2.4	6.6.2.4
Occupied bandwidth	6.6.3	6.6.3	6.6.3
ACLR	6.6.4.1	6.6.4.1	6.6.4.3
	6.6.4.3		
Cumulative ACLR	6.6.4.4 (NOTE 2)	6.6.4.4 (NOTE 2)	6.6.4.4 (NOTE 2)
Transmitter intermodulation	6.7.1	6.7.1	6.7.1
	6.7.3	6.7.3 6.7.4	6.7.3
Reference sensitivity level	7.2.1	7.2.1	7.2.3
	7.2.3		
Dynamic range	7.3.1	7.3.1	7.3.3
	7.3.3		
In-band selectivity and blocking			
Blocking	7.4.1	7.4.1	7.4.1
	7.4.5	7.4.5	7.4.5
Narrowband blocking	7.4.2	7.4.2	7.4.2
Out-of-band blocking	7.5	7.5	7.5
Receiver spurious emissions	7.6.1	7.6.1	7.6.1
Receiver intermodulation			
Intermodulation	7.7.1	7.7.1	7.7.1
Narrowband intermodulation	7.7.2	7.7.2	7.7.2
In-channel selectivity	7.8	7.8	-
Performance requirements	8.1	8.1	8.3
	8.3		
Note 1:	For some requirements in BS configured for multi-RAT operation, there is no general MSR multi-RAT requirement. Instead, the requirement is defined by the respective single-RAT requirement for each RAT supported by the BS as referenced in the table.		
NOTE 2:	The requirement in sub-clause 6.6.4.4 is only applied for BS operating in non-contiguous spectrum.		

## 5.4 Inclusion of requirements by reference

Many requirements in the present specification are not explicitly stated in the clauses listed in Tables 5.3-1, 5.3-2 and 5.3-3, but are instead included by reference to the respective single-RAT specifications. Each reference is normative and identifies the clause where the requirement is specified.

In some cases, the referenced clause may contain requirements that for different reasons do not apply for an MSR base station. It is in those cases stated that “applicable parts of” the referenced clause apply. What parts are applicable is determined by the scope of the MSR specification. For example:

- In a referenced clause including requirements for multiple operating bands, only requirements for bands listed in the present document apply.
- In a referenced clause that includes requirements for different types of base stations, only requirements for Wide Area BS apply in case of UTRA. For GSM/EDGE, only requirements for Multicarrier BTS and/or Normal BTS apply.

---

## 6 Transmitter characteristics

### 6.1 General

Unless otherwise stated, the requirements in clause 6 are expressed for a single transmitter antenna connector. In case of multi-carrier transmission with multiple transmitter antenna connectors, transmit diversity, DB-DC-HSDPA or MIMO transmission, the requirements apply for each transmitter antenna connector.

A BS supporting DC-HSDPA and DB-DC-HSDPA transmits two UTRA FDD cells simultaneously. A BS supporting DC-HSDPA transmits two UTRA FDD cells simultaneously on adjacent carrier frequencies.

Unless otherwise stated, the transmitter characteristics are specified at the BS antenna connector (test port A) with a full complement of transceivers for the configuration in normal operating conditions. If any external apparatus such as a TX amplifier, a filter or the combination of such devices is used, requirements apply at the far end antenna connector (test port B).

Unless otherwise stated the requirements in subclause 6 applies at all times, i.e. during the Transmitter ON period, the Transmitter OFF period and the Transmitter transient period.

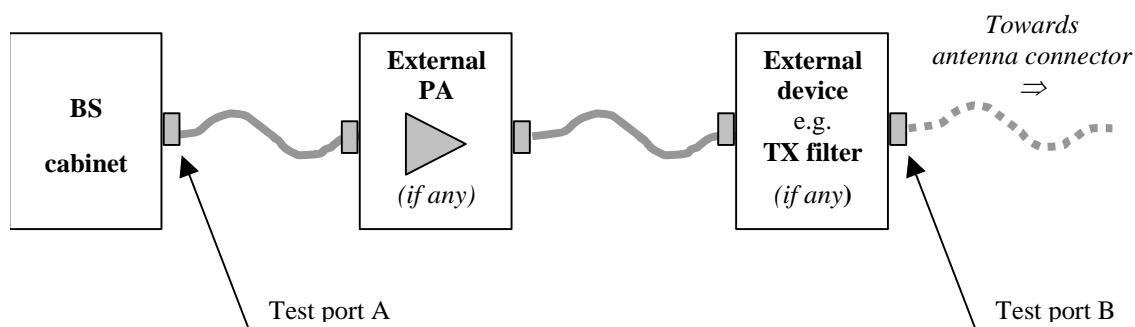

Figure 6.1-1: Transmitter test ports

Values for  $F_{\text{offset,RAT}}$  to meet transmitter requirements are specific for each RAT in each Band Category as specified in subclause 4.5.1 for Band Category 1, subclause 4.5.2 for Band Category 2 and subclause 4.5.3 for Band Category 3.

### 6.2 Base station output power

Output power of the base station is the mean power delivered to a load with resistance equal to the nominal load impedance of the transmitter.

The configured carrier power is the target maximum power for a specific carrier for the operating mode set in the BS within the limits given by the manufacturer's declaration.

The maximum total output power,  $P_{\max}$ , of the base station is the mean power level measured at the antenna connector during the transmitter ON period in a specified reference condition.

The maximum RAT output power,  $P_{\max,RAT}$ , of the base station is the mean power level measured at the antenna connector during the transmitter ON period for a specific RAT in a specified reference condition.

The maximum carrier output power,  $P_{\max,c}$  of the base station is the mean power level measured at the antenna connector during the transmitter ON period for a specific carrier in a specified reference condition.

The rated carrier output power,  $P_{\text{Rated},c}$ , of the base station is the mean power level for a specific carrier that the manufacturer has declared to be available at the antenna connector during the transmitter ON period.

The rated carrier output power of the BS shall be as specified in Table 6.2-1.

**Table 6.2-1 Base Station rated carrier output power**

BS class	$P_{\text{Rated},c}$
Wide Area BS	(note)
Medium Range BS	$\leq +38$ dBm
Local Area BS	$\leq +24$ dBm
NOTE: There is no upper limit for the rated carrier output power of the Wide Area Base Station.	

## 6.2.1 Minimum requirement

In normal conditions, the maximum carrier output power shall remain within +2 dB and -2 dB of the configured carrier power declared by the manufacturer.

In extreme conditions, maximum carrier output power shall remain within +2.5 dB and -2.5 dB of the configured carrier power declared by the manufacturer.

The definition of the output power parameters declared by the manufacturer can be found in TS 37.141 [10].

In certain regions, the minimum requirement for normal conditions may apply also for some conditions outside the range of conditions defined as normal.

## 6.2.2 Additional requirement (regional)

For Band 34 operation in Japan, the rated E-UTRA output power declared by the manufacturer shall be less than or equal to the values specified in Table 6.2.2-1.

**Table 6.2.2-1: Regional requirements for Band 34 for rated output power declared by the manufacturer.**

Channel bandwidth $BW_{\text{Channel}}$ [MHz]	1.4	3	5	10	15	20
Maximum output power [W]	N/A	N/A	20	40	60	N/A

For Band 41 operation in Japan, the rated output power per BS declared by the manufacturer shall be less than or equal to the values specified in Table 6.2.2-2.

**Table 6.2.2-2: Regional requirements for Band 41 for rated output power declared by the manufacturer.**

Channel bandwidth $BW_{\text{Channel}}$ [MHz]	1.4	3	5	10	15	20
Maximum output power [W]	N/A	N/A	N/A	20	N/A	40

### 6.2.3 E-UTRA minimum requirement for DL RS power

For E-UTRA, the minimum requirement for DL RS power is specified in TS 36.104 [4], subclause 6.5.4.

### 6.2.4 UTRA FDD minimum requirement for primary CPICH power

For UTRA FDD, the minimum requirements for primary CPICH power is specified in TS 25.104 [2], subclause 6.4.4,

### 6.2.5 UTRA TDD minimum requirement for primary CCPCH power

For UTRA TDD, the minimum requirements for Primary CCPCH power and Differential accuracy of primary CCPCH power specified in TS 25.105 [3], subclause 6.4.5 and 6.4.6 respectively.

## 6.3 Output power dynamics

Output power dynamics is defined by the BS transmitter's ability to operate at varying output power levels.

### 6.3.1 E-UTRA minimum requirement

For E-UTRA, the minimum requirement for output power dynamics is specified in TS 36.104 [4], subclause 6.3.

### 6.3.2 UTRA FDD minimum requirement

For UTRA FDD, the minimum requirement for output power dynamics is specified in TS 25.104 [2], subclause 6.4.

### 6.3.3 UTRA TDD minimum requirement

For UTRA TDD, the minimum requirement for output power dynamics is specified in TS 25.105 [3], subclause 6.4.

### 6.3.4 GSM/EDGE minimum requirement

For GSM/EDGE, the minimum requirement for output power dynamics is specified in TS 45.005[5], subclause 4.1.2-c. The minimum requirement for output level dynamic operation is specified in TS 45.005[5], subclause 4.5.1.

## 6.4 Transmit ON/OFF power

The requirements in subclause 6.4 are only applied for BC3 BS.

### 6.4.1 Transmitter OFF power

Transmitter OFF power is defined as the mean power measured over 70  $\mu$ s filtered with a square filter of bandwidth equal to the RF bandwidth(s) of the BS centred on the central frequency of the RF bandwidth(s) during the transmitter OFF period.



### 6.4.1.1 Minimum Requirement

The transmitter OFF power spectral density shall be less than -85 dBm/MHz.

For BS capable of multi-band operation, the requirement is only applicable during the transmitter OFF period in all supported operating bands.

### 6.4.2 Transmitter transient period

The transmitter transient period is the time period during which the transmitter is changing from the OFF period to the ON period or vice versa. The transmitter transient period is illustrated in Figure 6.4.2-1.

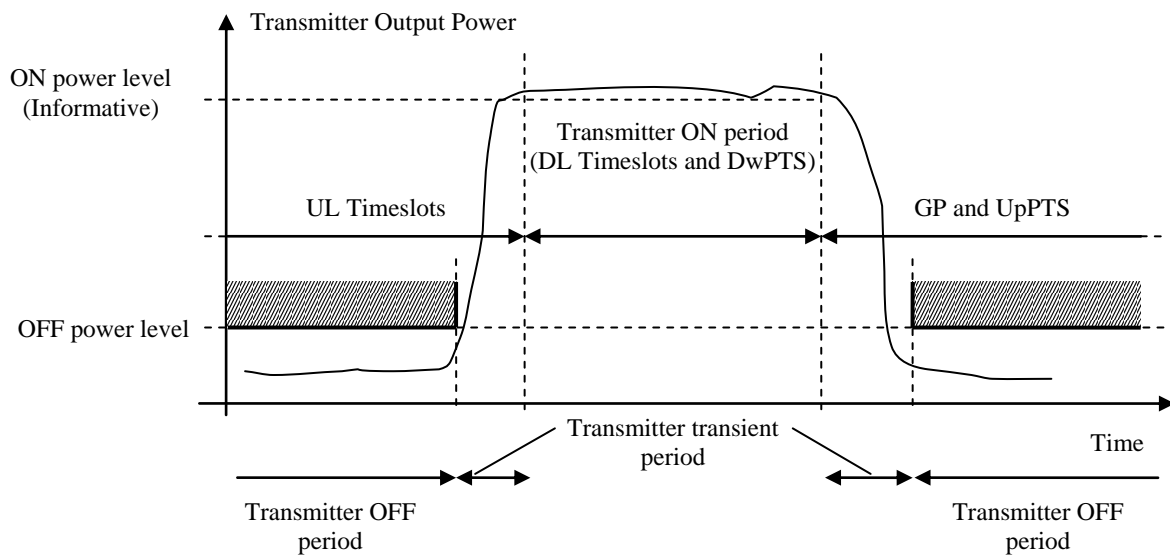

**Figure 6.4.2-1: Illustration of the relations of transmitter ON period, transmitter OFF period and transmitter transient period.**

#### 6.4.2.1 Minimum requirements

The transmitter transient period shall be shorter than the values listed in Table 6.4.2.1-1.

**Table 6.4.2.1-1: Minimum requirements for the transmitter transient period**

Transition	Transient period length [ $\mu$ s]
OFF to ON	6.25
ON to OFF	17

## 6.5 Transmitted signal quality

### 6.5.1 Modulation quality

Modulation quality is defined by the difference between the measured carrier signal and a reference signal. Modulation quality can e.g. be expressed as Error Vector Magnitude (EVM), Peak Code domain Error (PCDE) or Relative Code domain Error (RCDE).

#### 6.5.1.1 E-UTRA minimum requirement

For E-UTRA, the minimum requirement for modulation quality, EVM, is specified in TS 36.104 [4], subclause 6.5.2.

### 6.5.1.2 UTRA FDD minimum requirement

For UTRA FDD, the minimum requirements for modulation quality, EVM, PCDE and RCDE, are specified in TS 25.104 [2], subclause 6.8.2, 6.8.3 and 6.8.5 respectively. The UTRA transmit pulse shape filter is defined in subclause 6.8.1.

### 6.5.1.3 UTRA TDD minimum requirement

For UTRA TDD, the minimum requirements for modulation quality, EVM, PCDE and RCDE, are specified in TS 25.105 [3], subclause 6.8.2, 6.8.3 and 6.8.4 respectively.

### 6.5.1.4 GSM/EDGE minimum requirement

For GSM/EDGE, the minimum requirements for modulation accuracy are specified in TS 45.005 [5], subclause 4.6 .

## 6.5.2 Frequency error

Frequency error is a measure of the difference between the actual BS transmit frequency and the assigned frequency. The same source shall be used for RF frequency and data clock generation.

### 6.5.2.1 E-UTRA minimum requirement

For E-UTRA, the minimum requirement for frequency error is specified in TS 36.104 [4], subclause 6.5.1.

### 6.5.2.2 UTRA FDD minimum requirement

For UTRA FDD, the minimum requirement for frequency error is specified in TS 25.104 [2], subclause 6.3.1.

### 6.5.2.3 UTRA TDD minimum requirement

For UTRA TDD, the minimum requirement for frequency error is specified in TS 25.105 [3], subclause 6.3.1.

### 6.5.2.4 GSM/EDGE minimum requirement

For GSM/EDGE, the minimum requirement for frequency error is specified in TS 45.005 [5], subclause 4.4 .

## 6.5.3 Time alignment error

This requirement applies to frame timing in:

- UTRA single/multi-carrier transmissions, and their combinations with MIMO or TX diversity.
- E-UTRA single/multi-carrier transmissions, and their combinations with MIMO or TX diversity.
- E-UTRA Carrier Aggregation, with or without MIMO or TX diversity.

Frames of the WCDMA/LTE signals present at the BS transmitter antenna connector(s) are not perfectly aligned in time. In relation to each other, the RF signals present at the BS transmitter antenna connector (s) experience certain timing differences.

For a specific set of signals/transmitter configuration/transmission mode, the Time Alignment Error (TAE) is defined as the largest timing difference between any two signals.

### 6.5.3.1 E-UTRA minimum Requirement

For E-UTRA, the minimum requirement for time alignment is specified in TS 36.104 [4], subclause 6.5.3.

### 6.5.3.2 UTRA FDD minimum requirement

For UTRA FDD, the minimum requirement for time alignment is specified in TS 25.104 [2], subclause 6.8.4.

### 6.5.3.3 UTRA TDD minimum requirement

For UTRA TDD, the minimum requirement for time alignment is specified in TS 25.105 [3], subclause 6.8.5.

## 6.6 Unwanted emissions

Unwanted emissions consist of out-of-band emissions and spurious emissions [6]. Out of band emissions are unwanted emissions immediately outside the channel bandwidth resulting from the modulation process and non-linearity in the transmitter but excluding spurious emissions. Spurious emissions are emissions which are caused by unwanted transmitter effects such as harmonics emission, parasitic emission, intermodulation products and frequency conversion products, but exclude out of band emissions.

The out-of-band emissions requirement for the BS transmitter is specified in terms of an Operating band unwanted emissions requirement that defines limits for emissions in each supported downlink operating band plus the frequency ranges 10 MHz above and 10 MHz below each band. Emissions outside of this frequency range are limited by a spurious emissions requirement.

There is in addition a requirement for occupied bandwidth and an ACLR requirement applicable for some RATs.

### 6.6.1 Transmitter spurious emissions

The transmitter spurious emission limits apply from 9 kHz to 12.75 GHz, excluding the frequency range from 10 MHz below the lowest frequency of the downlink operating band up to 10 MHz above the highest frequency of the downlink operating band. For BS capable of multi-band operation where multiple bands are mapped on the same antenna connector, this exclusion applies for each supported operating band. For BS capable of multi-band operation where multiple bands are mapped on separate antenna connectors, the single-band requirements apply and the multi-band exclusions and provisions are not applicable.

Exceptions are the requirements in Table 6.6.1.3.1-2 and specifically stated exceptions in Table 6.6.1.3.1-1 that apply also closer than 10 MHz from the downlink operating band. For some operating bands the upper frequency limit is higher than 12.75 GHz.

The requirements shall apply whatever the type of transmitter considered. It applies for all transmission modes foreseen by the manufacturer's specification. Unless otherwise stated, all requirements are measured as mean power (RMS).

### 6.6.1.1 Mandatory Requirements

The requirements of either subclause 6.6.1.1.1 (Category A limits) or subclause 6.6.1.1.2 (Category B limits) shall apply. In addition for a BS operating in Band Category 2, the requirements of 6.6.1.1.3 shall apply in case of Category B limits when GSM/EDGE is configured.

#### 6.6.1.1.1 Minimum requirement (Category A)

The power of any spurious emission shall not exceed the limits in Table 6.6.1.1.1-1

**Table 6.6.1.1.1-1: BS Spurious emission limits, Category A**

Frequency range	Maximum level	Measurement Bandwidth	Note
9kHz - 150kHz	-13 dBm	1 kHz	Note 1
150kHz - 30MHz		10 kHz	Note 1
30MHz - 1GHz		100 kHz	Note 1
1GHz - 12.75 GHz		1 MHz	Note 2
12.75 GHz – 5 <sup>th</sup> harmonic of the upper frequency edge of the DL operating band in GHz		1 MHz	Note 2, Note 3
NOTE 1: Bandwidth as in ITU-R SM.329 [2] , s4.1			
NOTE 2: Bandwidth as in ITU-R SM.329 [2] , s4.1. Upper frequency as in ITU-R SM.329 [2] , s2.5 table 1			
NOTE 3: Applies only for Bands 22, 42 and 43.			

#### 6.6.1.1.2 Minimum requirement (Category B)

The power of any spurious emission shall not exceed the limits in Table 6.6.1.1.2-1

**Table 6.6.1.1.2-1: BS Spurious emissions limits, Category B**

Frequency range	Maximum Level	Measurement Bandwidth	Note
9 kHz ↔ 150 kHz	-36 dBm	1 kHz	Note 1
150 kHz ↔ 30 MHz	-36 dBm	10 kHz	Note 1
30 MHz ↔ 1 GHz	-36 dBm	100 kHz	Note 1
1 GHz ↔ 12.75 GHz	-30 dBm	1 MHz	Note 2
12.75 GHz ↔ 5 <sup>th</sup> harmonic of the upper frequency edge of the DL operating band in GHz	-30 dBm	1 MHz	Note 2, Note 3
NOTE 1: Bandwidth as in ITU-R SM.329 [2] , s4.1			
NOTE 2: Bandwidth as in ITU-R SM.329 [2] , s4.1. Upper frequency as in ITU-R SM.329 [2] , s2.5 table 1			
NOTE 3: Applies only for Bands 22, 42 and 43.			

#### 6.6.1.1.3 Additional minimum requirement for BC2 (Category B)

For a BS operating in Band Category 2 when GSM/EDGE is configured, the power of any spurious emission shall not exceed the limits in Table 6.6.1.1.3-1.

For BS capable of multi-band operation, the limits in Table 6.6.1.1.3-1 are only applicable when all supported operating bands belong to BC2 and GSM/EDGE is configured in all bands.

**Table 6.6.1.1.3-1: Additional BS Spurious emissions limits for BC2, Category B**

Frequency range	Frequency offset from downlink operating band edge (Note1)	Maximum Level	Measurement Bandwidth
500 MHz ↔ 1 GHz	10 – 20 MHz	-36 dBm	300 kHz
	20 – 30 MHz	-36 dBm	1 MHz
	≥ 30 MHz	-36 dBm	3 MHz
1 GHz ↔ 12.75 GHz	≥ 30 MHz	-30 dBm	3 MHz
NOTE 1: For BS capable of multi-band operation, the frequency offset is relative to the closest operating band.			

### 6.6.1.2 Protection of the BS receiver of own or different BS

This requirement shall be applied for FDD operation in order to prevent the receivers of Base Stations being desensitised by emissions from the BS transmitter. It is measured at the transmit antenna port for any type of BS which has common or separate Tx/Rx antenna ports.

#### 6.6.1.2.1 Minimum Requirement

The power of any spurious emission shall not exceed the limits in Table 6.6.1.2.1-1 depending on the declared Base Station class and Band Category.

**Table 6.6.1.2.1-1: BS Spurious emissions limits for protection of the BS receiver**

BS-class	Band category	Frequency range	Maximum Level	Measurement Bandwidth	Note
Wide Area BS	BC1	$F_{UL\_low} - F_{UL\_high}$	-96 dBm	100 kHz	
Wide Area BS	BC2	$F_{UL\_low} - F_{UL\_high}$	-98 dBm	100 kHz	
Medium Range BS	BC1,BC2	$F_{UL\_low} - F_{UL\_high}$	-91 dBm	100 kHz	
Local Area BS	BC1,BC2	$F_{UL\_low} - F_{UL\_high}$	-88 dBm	100 kHz	

### 6.6.1.3 Additional spurious emissions requirements

These requirements may be applied for the protection of system operating in frequency ranges other than the BS downlink operating band. The limits may apply as an optional protection of such systems that are deployed in the same geographical area as the BS, or they may be set by local or regional regulation as a mandatory requirement for an operating band. It is in some cases not stated in the present document whether a requirement is mandatory or under what exact circumstances that a limit applies, since this is set by local or regional regulation. An overview of regional requirements in the present document is given in subclause 4.4.

Some requirements may apply for the protection of specific equipment (UE, MS and/or BS) or equipment operating in specific systems (GSM/EDGE, CDMA, UTRA, E-UTRA, etc.) as listed below.

#### 6.6.1.3.1 Minimum Requirement

The power of any spurious emission shall not exceed the limits of Table 6.6.1.3.1-1 for a BS where requirements for co-existence with the system listed in the first column apply. For BS capable of multi-band operation, the exclusions and conditions in the Note column of Table 6.6.1.3.1-1 apply for each supported operating band.

**Table 6.6.1.3.1-1: BS Spurious emissions limits for co-existence with systems operating in other frequency bands**

System type to co-exist with	Frequency range for co-existence requirement	Maximum Level	Measurement Bandwidth	Note
GSM900	921 - 960 MHz	-57 dBm	100 kHz	This requirement does not apply to BS operating in band 8
	876 - 915 MHz	-61 dBm	100 kHz	For the frequency range 880-915 MHz, this requirement does not apply to BS operating in band 8, since it is already covered by the requirement in sub-clause 6.6.1.2.
DCS1800 (Note 3)	1805 - 1880 MHz	-47 dBm	100 kHz	This requirement does not apply to BS operating in band 3.
	1710 - 1785 MHz	-61 dBm	100 kHz	This requirement does not apply to BS operating in band 3, since it is already covered by the requirement in sub-clause 6.6.1.2.
PCS1900	1930 - 1990 MHz	-47 dBm	100 kHz	This requirement does not apply to BS operating in band 2, 25 or band 36.
	1850 - 1910 MHz	-61 dBm	100 kHz	This requirement does not apply to BS operating in band 2 or 25, since it is already covered by the requirement in sub-clause 6.6.1.2. This requirement does not apply to BS operating in band 35.
GSM850 or CDMA850	869 - 894 MHz	-57 dBm	100 kHz	This requirement does not apply to BS operating in band 5 or 26. This requirement applies to E-UTRA BS operating in Band 27 for the frequency range 879-894 MHz.
	824 - 849 MHz	-61 dBm	100 kHz	This requirement does not apply to BS operating in band 5 or 26, since it is already covered by the requirement in sub-clause 6.6.1.2. For BS operating in Band 27, it applies 3 MHz below the Band 27 downlink operating band.
UTRA FDD Band I or E-UTRA Band 1	2110 - 2170 MHz	-52 dBm	1 MHz	This requirement does not apply to BS operating in band 1,
	1920 - 1980 MHz	-49 dBm	1 MHz	This requirement does not apply to BS operating in band 1, since it is already covered by the requirement in sub-clause 6.6.1.2.
UTRA FDD Band II or E-UTRA Band 2	1930 - 1990 MHz	-52 dBm	1 MHz	This requirement does not apply to BS operating in band 2 or 25.
	1850 - 1910 MHz	-49 dBm	1 MHz	This requirement does not apply to BS operating in band 2 or 25, since it is already covered by the requirement in sub-clause 6.6.1.2
UTRA FDD Band III or E-UTRA Band 3 (Note 3)	1805 - 1880 MHz	-52 dBm	1 MHz	This requirement does not apply to BS operating in band 3 or 9.
	1710 - 1785 MHz	-49 dBm	1 MHz	This requirement does not apply to BS operating in band 3, since it is already covered by the requirement in sub-clause 6.6.1.2. For BS operating in band 9, it applies for 1710 MHz to 1749.9 MHz and 1784.9 MHz to 1785 MHz, while the rest is covered in sub-clause 6.6.1.2.
UTRA FDD Band IV or E-UTRA Band 4	2110 - 2155 MHz	-52 dBm	1 MHz	This requirement does not apply to BS operating in band 4 or 10
	1710 - 1755 MHz	-49 dBm	1 MHz	This requirement does not apply to BS operating in band 4 or 10, since it is already covered by the requirement in sub-clause 6.6.1.2.
UTRA FDD Band V or E-UTRA Band 5	869 - 894 MHz	-52 dBm	1 MHz	This requirement does not apply to BS operating in band 5 or 26. This requirement applies to E-UTRA BS operating in Band 27 for the frequency range 879-894 MHz.
	824 - 849 MHz	-49 dBm	1 MHz	This requirement does not apply to BS operating in band 5 or 26, since it is already covered by the requirement in sub-clause 6.6.1.2. For BS operating in Band 27, it applies 3 MHz below the Band 27 downlink operating band.
UTRA FDD Band VI, XIX or	860 - 890 MHz	-52 dBm	1 MHz	This requirement does not apply to BS operating in band 6, 18, 19

E-UTRA Band 6, 18, 19	815 - 830 MHz	-49 dBm	1 MHz	This requirement does not apply to BS operating in band 18 since it is already covered by the requirement in sub-clause 6.6.1.2.
	830 - 845 MHz	-49 dBm	1 MHz	This requirement does not apply to BS operating in band 6, 19, since it is already covered by the requirement in sub-clause 6.6.1.2.
UTRA FDD Band VII or E-UTRA Band 7	2620 - 2690 MHz	-52 dBm	1 MHz	This requirement does not apply to BS operating in band 7.
	2500 - 2570 MHz	-49 dBm	1 MHz	This requirement does not apply to BS operating in band 7, since it is already covered by the requirement in sub-clause 6.6.1.2.
UTRA FDD Band VIII or E-UTRA Band 8	925 - 960 MHz	-52 dBm	1 MHz	This requirement does not apply to BS operating in band 8.
	880 - 915 MHz	-49 dBm	1 MHz	This requirement does not apply to BS operating in band 8, since it is already covered by the requirement in sub-clause 6.6.1.2.
UTRA FDD Band IX or E-UTRA Band 9	1844.9 - 1879.9 MHz	-52 dBm	1 MHz	This requirement does not apply to BS operating in band 3 or 9.
	1749.9 - 1784.9 MHz	-49 dBm	1 MHz	This requirement does not apply to BS operating in band 3 or 9, since it is already covered by the requirement in sub-clause 6.6.1.2.
UTRA FDD Band X or E-UTRA Band 10	2110 - 2170 MHz	-52 dBm	1 MHz	This requirement does not apply to BS operating in band 4 or 10
	1710 - 1770 MHz	-49 dBm	1 MHz	This requirement does not apply to BS operating in band 10, since it is already covered by the requirement in sub-clause 6.6.1.2. For BS operating in Band 4, it applies for 1755 MHz to 1770 MHz, while the rest is covered in sub-clause 6.6.1.2.
UTRA FDD Band XI or XXI or E-UTRA Band 11 or 21	1475.9 - 1510.9 MHz	-52 dBm	1 MHz	This requirement does not apply to BS operating in band 11 or 21
	1427.9 - 1447.9 MHz	-49 dBm	1 MHz	This requirement does not apply to BS operating in band 11, since it is already covered by the requirement in sub-clause 6.6.1.2.
	1447.9 - 1462.9 MHz	-49 dBm	1 MHz	This requirement does not apply to BS operating in band 21, since it is already covered by the requirement in sub-clause 6.6.1.2.
UTRA FDD Band XII or E-UTRA Band 12	729 - 746 MHz	-52 dBm	1 MHz	This requirement does not apply to BS operating in band 12.
	699 - 716 MHz	-49 dBm	1 MHz	This requirement does not apply to BS operating in band 12, since it is already covered by the requirement in sub-clause 6.6.1.2. For BS operating in Band 29, it applies 1 MHz below the Band 29 downlink operating band (Note 7)
UTRA FDD Band XIII or E-UTRA Band 13	746 - 756 MHz	-52 dBm	1 MHz	This requirement does not apply to BS operating in band 13.
	777 - 787 MHz	-49 dBm	1 MHz	This requirement does not apply to BS operating in band 13, since it is already covered by the requirement in sub-clause 6.6.1.2.
UTRA FDD Band XIV or E-UTRA Band 14	758 - 768 MHz	-52 dBm	1 MHz	This requirement does not apply to BS operating in band 14.
	788 - 798 MHz	-49 dBm	1 MHz	This requirement does not apply to BS operating in band 14, since it is already covered by the requirement in sub-clause 6.6.1.2.
E-UTRA Band 17	734 - 746 MHz	-52 dBm	1 MHz	This requirement does not apply to BS operating in band 17.
	704 - 716 MHz	-49 dBm	1 MHz	This requirement does not apply to BS operating in band 17, since it is already covered by the requirement in subclause 6.6.1.2. For BS operating in Band 29, it applies 1 MHz below the Band 29 downlink operating band (Note 7)
UTRA FDD Band XX or E-UTRA Band 20	791 - 821 MHz	-52 dBm	1 MHz	This requirement does not apply to BS operating in band 20.
	832 - 862 MHz	-49 dBm	1 MHz	This requirement does not apply to BS operating in band 20, since it is already covered by the requirement in subclause 6.6.1.2.
UTRA FDD Band XXII or	3510 - 3590 MHz	-52 dBm	1 MHz	This requirement does not apply to BS operating in band 22 or 42.

E-UTRA Band 22	3410 – 3490 MHz	-49 dBm	1 MHz	This requirement does not apply to BS operating in band 22, since it is already covered by the requirement in subclause 6.6.4.2. This requirement does not apply to Band 42.
E-UTRA Band 23	2180 - 2200 MHz	-52 dBm	1 MHz	This requirement does not apply to BS operating in band 23.
	2000 - 2020 MHz	-49 dBm	1 MHz	This requirement does not apply to BS operating in band 23, since it is already covered by the requirement in subclause 6.6.1.2. This requirement does not apply to BS operating in Bands 2 or 25, where the limits are defined separately.
	2000 - 2010 MHz	-30 dBm	1 MHz	This requirement only applies to BS operating in Band 2 or Band 25. This requirement applies starting 5 MHz above the Band 25 downlink operating band. (Note 5)
	2010 - 2020 MHz	-49 dBm	1 MHz	
E-UTRA Band 24	1525 – 1559 MHz	-52 dBm	1 MHz	This requirement does not apply to BS operating in band 24.
	1626.5 – 1660.5 MHz	-49 dBm	1 MHz	This requirement does not apply to BS operating in band 24, since it is already covered by the requirement in subclause 6.6.1.2.
UTRA FDD Band XXV or E-UTRA Band 25	1930 - 1995 MHz	-52 dBm	1 MHz	This requirement does not apply to BS operating in band 2 or 25.
	1850 - 1915 MHz	-49 dBm	1 MHz	This requirement does not apply to BS operating in band 25, since it is already covered by the requirement in sub-clause 6.6.1.2. For BS operating in Band 2, it applies for 1910 MHz to 1915 MHz, while the rest is covered in sub-clause 6.6.1.2.
UTRA FDD Band XXVI or E-UTRA Band 26	859 - 894 MHz	-52 dBm	1 MHz	This requirement does not apply to BS operating in band 5 or 26. This requirement applies to E-UTRA BS operating in Band 27 for the frequency range 879-894 MHz.
	814 - 849 MHz	-49 dBm	1 MHz	This requirement does not apply to BS operating in band 26, since it is already covered by the requirement in sub-clause 6.6.1.2. For BS operating in Band 5, it applies for 814 MHz to 824 MHz, while the rest is covered in sub-clause 6.6.1.2. For BS operating in Band 27, it applies 3 MHz below the Band 27 downlink operating band.
E-UTRA Band 27	852 – 869 MHz	-52 dBm	1 MHz	This requirement does not apply to BS operating in bands 5, 26 or 27.
	807 – 824 MHz	-49 dBm	1 MHz	This requirement does not apply to BS operating in band 27, since it is already covered by the requirement in subclause 6.6.1.2. For BS operating in Band 26, it applies for 807 MHz to 814 MHz, while the rest is covered in sub-clause 6.6.1.2. This requirement also applies to BS operating in Band 28, starting 4 MHz above the Band 28 downlink operating band (Note 6).
E-UTRA Band 28	758 - 803 MHz	-52 dBm	1 MHz	This requirement does not apply to BS operating in band 28 or 44.
	703 - 748 MHz	-49 dBm	1 MHz	This requirement does not apply to BS operating in band 28, since it is already covered by the requirement in sub-clause 6.6.1.2. This requirement does not apply to BS operating in Band 44.
E-UTRA Band 29	717 – 728 MHz	-52 dBm	1 MHz	This requirement does not apply to BS operating in Band 29
UTRA TDD Band a) or E-UTRA Band 33	1900 - 1920 MHz	-52 dBm	1 MHz	This requirement does not apply to BS operating in Band 33
UTRA TDD Band a) or E-UTRA Band 34	2010 - 2025 MHz	-52 dBm	1 MHz	This requirement does not apply to BS operating in Band 34
UTRA TDD Band b) or E-UTRA Band 35	1850 – 1910 MHz	-52 dBm	1 MHz	This requirement does not apply to BS operating in Band 35
UTRA TDD Band b) or E-UTRA Band 36	1930 - 1990 MHz	-52 dBm	1 MHz	This requirement does not apply to BS operating in Band 2, 25 or 36



UTRA TDD Band c) or E-UTRA Band 37	1910 - 1930 MHz	-52 dBm	1 MHz	This is not applicable to BS operating in Band 37. This unpaired band is defined in ITU-R M.1036, but is pending any future deployment.
UTRA TDD Band d) or E-UTRA Band 38	2570 – 2620 MHz	-52 dBm	1 MHz	This requirement does not apply to BS operating in Band 38.
UTRA TDD Band f) or E-UTRA Band 39	1880 – 1920MHz	-52 dBm	1 MHz	This is not applicable to BS operating in Band 39
UTRA TDD Band e) or E-UTRA Band 40	2300 – 2400MHz	-52 dBm	1 MHz	This is not applicable to BS operating in Band 40
E-UTRA Band 41	2496 – 2690MHz	-52 dBm	1 MHz	This is not applicable to BS operating in Band 41
E-UTRA Band 42	3400 – 3600 MHz	-52 dBm	1 MHz	This is not applicable to BS operating in Band 42 or 43
E-UTRA Band 43	3600 – 3800 MHz	-52 dBm	1 MHz	This is not applicable to BS operating in Band 42 or 43
E-UTRA Band 44	703 - 803 MHz	-52 dBm	1 MHz	This is not applicable to BS operating in Band 28 or 44
NOTE 5: This requirement does not apply to a Band 2 BS of an earlier release. In addition, it does not apply to an Band 2 BS from an earlier release manufactured before 31 December, 2012, which is upgraded to support Rel-10 features, where the upgrade does not affect existing RF parts of the radio unit related to this requirement.				

NOTE 1: As defined in the scope for spurious emissions in this subclause, except for the cases where the noted requirements apply to a BS operating in Band 25, Band 27, Band 28 or Band 29, the co-existence requirements in Table 6.6.1.3.1-1 do not apply for the 10 MHz frequency range immediately outside the downlink operating band (see Tables 4.5-1 and 4.5-2). Emission limits for this excluded frequency range may be covered by local or regional requirements.

NOTE 2: Table 6.6.1.3.1-1 assumes that two operating bands, where the frequency ranges in Table 4.5-1 or Table 4.5-2 would be overlapping, are not deployed in the same geographical area. For such a case of operation with overlapping frequency arrangements in the same geographical area, special co-existence requirements may apply that are not covered by the 3GPP specifications.

NOTE 3: For the protection of DCS1800, UTRA Band III or E-UTRA Band 3 in China, the frequency ranges of the downlink and uplink protection requirements are 1805 – 1850 MHz and 1710 – 1755 MHz respectively.

NOTE 4: TDD base stations deployed in the same geographical area, that are synchronized and use the same or adjacent operating bands can transmit without additional co-existence requirements. For unsynchronized base stations, special co-existence requirements may apply that are not covered by the 3GPP specifications.

NOTE 6: For Band 28 BS, specific solutions may be required to fulfil the spurious emissions limits for BS for co-existence with Band 27 UL operating band.

NOTE 7: For Band 29 BS, specific solutions may be required to fulfil the spurious emissions limits for BS for co-existence with UTRA Band XII or E-UTRA Band 12 UL operating band or E-UTRA Band 17 UL operating band.

The following requirement may be applied for the protection of PHS. This requirement is also applicable at specified frequencies falling between 10 MHz below the lowest BS transmitter frequency of the downlink operating band and 10 MHz above the highest BS transmitter frequency of the downlink operating band.

The power of any spurious emission shall not exceed:

**Table 6.6.1.3.1-2: BS Spurious emissions limits for BS for co-existence with PHS**

Frequency range	Maximum Level	Measurement Bandwidth	Note
1884.5 - 1915.7 MHz	-41 dBm	300 kHz	Applicable for co-existence with PHS system operating in 1884.5-1915.7MHz
NOTE: The requirement is not applicable in China.			

The following requirement may apply to E-UTRA BS operating in Band 41 in certain regions. This requirement is also applicable at the frequency range from 10 MHz below the lowest frequency of the BS downlink operating band up to 10 MHz above the highest frequency of the BS downlink operating band.

The power of any spurious emission shall not exceed:

**Table 6.6.1.3.1-3: Additional BS Spurious emissions limits for Band 41**

Frequency range	Maximum Level	Measurement Bandwidth	Note
2505MHz – 2535MHz	-42dBm	1 MHz	
2535MHz – 2630MHz	-22dBm	1 MHz	Applicable at offsets $\geq 250\%$ of channel bandwidth from carrier frequency
2630MHz – 2655MHz	-30dBm	1 MHz	
NOTE: This requirement applies for 10 or 20 MHz E-UTRA carriers allocated within 2545-2575MHz.			

In addition to the requirements in subclauses 6.6.1.1, 6.6.1.2 and above in the present subclause, the BS may have to comply with the applicable emission limits established by FCC Title 47 [8], when deployed in regions where those limits are applied, and under the conditions declared by the manufacturer.

#### 6.6.1.4 Co-location with other base stations

These requirements may be applied for the protection of other BS receivers when GSM900, DCS1800, PCS1900, GSM850, CDMA850, UTRA FDD, UTRA TDD and/or E-UTRA BS are co-located with a BS.

The requirements assume a 30 dB coupling loss between transmitter and receiver and are based on co-location with base stations of the same class.

NOTE: For co-location with UTRA, the requirements are based on co-location with UTRA FDD or TDD base stations.

##### 6.6.1.4.1 Minimum Requirement

The power of any spurious emission shall not exceed the limits of Table 6.6.1.4.1-1 for a BS where requirements for co-location with a BS type listed in the first column apply, depending on the declared Base Station class. For BS capable of multi-band operation, the exclusions and conditions in the Note column of Table 6.6.1.4.1-1 apply for each supported operating band.

Table 6.6.1.4.1-1: BS Spurious emissions limits for BS co-located with another BS

Type of co-located BS	Frequency range for co-location requirement	Maximum Level (WA-BS)	Maximum Level (MR-BS)	Maximum Level (LA-BS)	Measurement Bandwidth	Note
GSM900	876-915 MHz	-98 dBm	-91 dBm	-88 dBm	100 kHz	
DCS1800	1710 - 1785 MHz	-98 dBm	-91 dBm	-88 dBm	100 kHz	
PCS1900	1850 - 1910 MHz	-98 dBm	-91 dBm	-88 dBm	100 kHz	
GSM850 or CDMA850	824 - 849 MHz	-98 dBm	-91 dBm	-88 dBm	100 kHz	
UTRA FDD Band I or E-UTRA Band 1	1920 - 1980 MHz	-96 dBm	-91 dBm	-88 dBm	100 kHz	
UTRA FDD Band II or E-UTRA Band 2	1850 - 1910 MHz	-96 dBm	-91 dBm	-88 dBm	100 kHz	
UTRA FDD Band III or E-UTRA Band 3	1710 - 1785 MHz	-96 dBm	-91 dBm	-88 dBm	100 kHz	
UTRA FDD Band IV or E-UTRA Band 4	1710 - 1755 MHz	-96 dBm	-91 dBm	-88 dBm	100 kHz	
UTRA FDD Band V or E-UTRA Band 5	824 - 849 MHz	-96 dBm	-91 dBm	-88 dBm	100 kHz	
UTRA FDD Band VI, XIX or E-UTRA Band 6, 19	830 - 845 MHz	-96 dBm	-91 dBm	-88 dBm	100 kHz	
UTRA FDD Band VII or E-UTRA Band 7	2500 - 2570 MHz	-96 dBm	-91 dBm	-88 dBm	100 kHz	
UTRA FDD Band VIII or E-UTRA Band 8	880 - 915 MHz	-96 dBm	-91 dBm	-88 dBm	100 kHz	
UTRA FDD Band IX or E-UTRA Band 9	1749.9 - 1784.9 MHz	-96 dBm	-91 dBm	-88 dBm	100 kHz	
UTRA FDD Band X or E-UTRA Band 10	1710 - 1770 MHz	-96 dBm	-91 dBm	-88 dBm	100 kHz	
UTRA FDD Band XI or E-UTRA Band 11	1427.9 - 1447.9 MHz	-96 dBm	-91 dBm	-88 dBm	100 kHz	
UTRA FDD Band XII or E-UTRA Band 12	699 - 716 MHz	-96 dBm	-91 dBm	-88 dBm	100 kHz	
UTRA FDD Band XIII or E-UTRA Band 13	777 - 787 MHz	-96 dBm	-91 dBm	-88 dBm	100 kHz	
UTRA FDD Band XIV or E-UTRA Band 14	788 - 798 MHz	-96 dBm	-91 dBm	-88 dBm	100 kHz	
E-UTRA Band 17	704 - 716 MHz	-96 dBm	-91 dBm	-88 dBm	100 kHz	
E-UTRA Band 18	815 - 830 MHz	-96 dBm	-91 dBm	-88 dBm	100 kHz	
UTRA FDD Band XX or E-UTRA Band 20	832 - 862 MHz	-96 dBm	-91 dBm	-88 dBm	100 kHz	
UTRA FDD Band XXI or E-UTRA Band 21	1447.9 – 1462.9 MHz	-96 dBm	-91 dBm	-88 dBm	100 kHz	

UTRA FDD Band XXII or E-UTRA Band 22	3410 – 3490 MHz	-96 dBm	-91 dBm	-88 dBm	100 kHz	This is not applicable to BS operating in Band 42
E-UTRA Band 23	2000 - 2020 MHz	-96 dBm	-91 dBm	-88 dBm	100 kHz	
E-UTRA Band 24	1626.5 – 1660.5 MHz	-96 dBm	-91 dBm	-88 dBm	100 kHz	
UTRA FDD Band XXV or E-UTRA Band 25	1850 - 1915 MHz	-96 dBm	-91 dBm	-88 dBm	100 kHz	
UTRA FDD Band XXVI or E-UTRA Band 26	814 - 849 MHz	-96 dBm	-91 dBm	-88 dBm	100 kHz	
E-UTRA Band 27	807 - 824 MHz	-96 dBm	-91 dBm	-88 dBm	100 kHz	
E-UTRA Band 28	703 – 748 MHz	-96 dBm	-91 dBm	-88 dBm	100 kHz	This is not applicable to BS operating in Band 44
UTRA TDD Band a) or E-UTRA Band 33	1900 - 1920 MHz	-96 dBm	-91 dBm	-88 dBm	100 kHz	This is not applicable to BS operating in Band 33
UTRA TDD Band a) or E-UTRA Band 34	2010 - 2025 MHz	-96 dBm	-91 dBm	-88 dBm	100 kHz	This is not applicable to BS operating in Band 34
UTRA TDD Band b) or E-UTRA Band 35	1850 – 1910 MHz	-96 dBm	-91 dBm	-88 dBm	100 kHz	This is not applicable to BS operating in Band 35
UTRA TDD Band b) or E-UTRA Band 36	1930 - 1990 MHz	-96 dBm	-91 dBm	-88 dBm	100 kHz	This is not applicable to BS operating in Band 2 and 36
UTRA TDD Band c) or E-UTRA Band 37	1910 - 1930 MHz	-96 dBm	-91 dBm	-88 dBm	100 kHz	This is not applicable to BS operating in Band 37. This unpaired band is defined in ITU-R M.1036, but is pending any future deployment.
UTRA TDD Band d) or E-UTRA Band 38	2570 – 2620 MHz	-96 dBm	-91 dBm	-88 dBm	100 kHz	This is not applicable to BS operating in Band 38.
UTRA TDD Band f) or E-UTRA Band 39	1880 – 1920MHz	-96 dBm	-91 dBm	-88 dBm	100 kHz	This is not applicable to BS operating in Band 33 and 39
UTRA TDD Band e) or E-UTRA Band 40	2300 – 2400MHz	-96 dBm	-91 dBm	-88 dBm	100 kHz	This is not applicable to BS operating in Band 40
E-UTRA Band 41	2496 – 2690MHz	-96 dBm	-91 dBm	-88 dBm	100 kHz	This is not applicable to BS operating in Band 41
E-UTRA Band 42	3400 – 3600 MHz	-96 dBm	-91 dBm	-88 dBm	100 kHz	This is not applicable to BS operating in Band 42 or 43

E-UTRA Band 43	3600 – 3800 MHz	-96 dBm	-91 dBm	-88 dBm	100 kHz	This is not applicable to BS operating in Band 42 or 43
E-UTRA Band 44	703 – 803 MHz	-96 dBm	-91 dBm	-88 dBm	100 kHz	This is not applicable to BS operating in Band 28 or 44

NOTE 1: As defined in the scope for spurious emissions in this subclause, the co-location requirements in Table 6.6.1.4.1-1 do not apply for the 10 MHz frequency range immediately outside the BS transmit frequency range of a downlink operating band (see Tables 4.5-1 and 4.5-2). The current state-of-the-art technology does not allow a single generic solution for co-location with other system on adjacent frequencies for 30 dB BS-BS minimum coupling loss. However, there are certain site-engineering solutions that can be used. These techniques are addressed in TR 25.942 [7].

NOTE 2: Table 6.6.1.4.1-1 assumes that two operating bands, where the corresponding BS transmit and receive frequency ranges in Table 4.5-1 or Table 4.5-2 would be overlapping, are not deployed in the same geographical area. For such a case of operation with overlapping frequency arrangements in the same geographical area, special co-location requirements may apply that are not covered by the 3GPP specifications.

NOTE 3: Co-located TDD base stations that are synchronized and using the same or adjacent operating band can transmit without special co-locations requirements. For unsynchronized base stations, special co-location requirements may apply that are not covered by the 3GPP specifications.

## 6.6.2 Operating band unwanted emissions

Unless otherwise stated, the Operating band unwanted emission limits are defined from 10 MHz below the lowest frequency of each supported downlink operating band to the lower RF bandwidth edge located at  $F_{BW,RF,low}$  and from the upper RF bandwidth edge located at  $F_{BW,RF,high}$  up to 10 MHz above the highest frequency of each supported downlink operating band.

The requirements shall apply whatever the type of transmitter considered and for all transmission modes foreseen by the manufacturer's specification, except for any operating band with GSM/EDGE single RAT operation. The requirements in TS 45.005 [5] as defined in subclause 6.6.2.3 apply to an MSR Base Station for any operating band with GSM/EDGE single RAT operation in Band Category 2.

For BS capable of multi-band operation where multiple bands are mapped on separate antenna connectors, the single-band requirements apply and the cumulative evaluation of the emission limit in the inter-RF bandwidth gap are not applicable.

### 6.6.2.1 General minimum requirement for Band Categories 1 and 3

For a Wide Area BS operating in Band Category 1 or Band Category 3 the requirement applies outside the RF bandwidth edges. In addition, for a Wide Area BS operating in non-contiguous spectrum, it applies inside any sub-block gap.

For a Medium Range BS operating in Band Category 1 the requirement applies outside the RF bandwidth edges. In addition, for a Medium Range BS operating in non-contiguous spectrum, it applies inside any sub-block gap.

For a Local Area BS operating in Band Category 1 the requirement applies outside the RF bandwidth edges. In addition, for a Local Area BS operating in non-contiguous spectrum, it applies inside any sub-block gap.

Outside the RF bandwidth edges, emissions shall not exceed the maximum levels specified in Tables 6.6.2.1-1 to 6.6.2.1-4 below, where:

- $\Delta f$  is the separation between the RF bandwidth edge frequency and the nominal -3 dB point of the measuring filter closest to the carrier frequency.
- $f_{\text{offset}}$  is the separation between the RF bandwidth edge frequency and the centre of the measuring filter.
- $f_{\text{offset}_{\text{max}}}$  is the offset to the frequency 10 MHz outside the downlink operating band.
- $\Delta f_{\text{max}}$  is equal to  $f_{\text{offset}_{\text{max}}}$  minus half of the bandwidth of the measuring filter.

For a BS operating in multiple bands, inside any inter RF bandwidth gaps with  $W_{\text{gap}} < 20$  MHz, emissions shall not exceed the cumulative sum of the minimum requirements specified at the RF bandwidth edges on each side of the inter-RF bandwidth gap. The minimum requirement for RF bandwidth edge is specified in Table 6.6.2.1-1 to 6.6.2.1-4 below, where in this case:

- $\Delta f$  is the separation between the RF bandwidth edge frequency and the nominal -3 dB point of the measuring filter closest to the carrier frequency.
- $f_{\text{offset}}$  is the separation between the RF bandwidth edge frequency and the centre of the measuring filter.
- $f_{\text{offset}_{\text{max}}}$  is equal to the inter RF bandwidth gap divided by two.
- $\Delta f_{\text{max}}$  is equal to  $f_{\text{offset}_{\text{max}}}$  minus half of the bandwidth of the measuring filter.

Inside any sub-block gap for a BS operating in non-contiguous spectrum, emissions shall not exceed the cumulative sum of the minimum requirements specified for the adjacent sub blocks on each side of the sub block gap. The minimum requirement for each sub block is specified in Tables 6.6.2.1-1 to 6.6.2.1-4 below, where in this case:

- $\Delta f$  is the separation between the sub block edge frequency and the nominal -3 dB point of the measuring filter closest to the sub block edge.
- $f_{\text{offset}}$  is the separation between the sub block edge frequency and the centre of the measuring filter.
- $f_{\text{offset}_{\text{max}}}$  is equal to the sub block gap bandwidth divided by two.
- $\Delta f_{\text{max}}$  is equal to  $f_{\text{offset}_{\text{max}}}$  minus half of the bandwidth of the measuring filter.

Table 6.6.2.1-1: Wide Area operating band unwanted emission mask (UEM) for BC1 and BC3

Frequency offset of measurement filter -3dB point, $\Delta f$	Frequency offset of measurement filter centre frequency, $f_{\text{offset}}$	Minimum requirement (Note 1, Note 2)	Measurement bandwidth (Note 4)
$0 \text{ MHz} \leq \Delta f < 0.2 \text{ MHz}$	$0.015 \text{ MHz} \leq f_{\text{offset}} < 0.215 \text{ MHz}$	-14 dBm	30 kHz
$0.2 \text{ MHz} \leq \Delta f < 1 \text{ MHz}$	$0.215 \text{ MHz} \leq f_{\text{offset}} < 1.015 \text{ MHz}$	$-14 \text{ dBm} - 15 \cdot \left( \frac{f_{\text{offset}}}{\text{MHz}} - 0.215 \right) \text{ dB}$	30 kHz
(Note 3)	$1.015 \text{ MHz} \leq f_{\text{offset}} < 1.5 \text{ MHz}$	-26 dBm	30 kHz
$1 \text{ MHz} \leq \Delta f \leq \min(\Delta f_{\text{max}}, 10 \text{ MHz})$	$1.5 \text{ MHz} \leq f_{\text{offset}} < \min(f_{\text{offset}_{\text{max}}}, 10.5 \text{ MHz})$	-13 dBm	1 MHz
$10 \text{ MHz} \leq \Delta f \leq \Delta f_{\text{max}}$	$10.5 \text{ MHz} \leq f_{\text{offset}} < f_{\text{offset}_{\text{max}}}$	-15 dBm (Note 5)	1 MHz
NOTE 1: For MSR BS supporting non-contiguous spectrum operation within any operating band the minimum requirement within sub-block gaps is calculated as a cumulative sum of contributions from adjacent sub-blocks on each side of the sub-block gap. Exception is $\Delta f \geq 10 \text{ MHz}$ from both adjacent sub-blocks on each side of the sub-block gap, where the minimum requirement within sub-block gaps shall be -15dBm/MHz.			
NOTE2: For MSR BS supporting multi-band operation with inter RF bandwidth gap < 20MHz the minimum requirement within the inter RF bandwidth gaps is calculated as a cumulative sum of contributions from adjacent sub-blocks on each side of the inter RF bandwidth gap.			

Table 6.6.2.1-2: Medium Range BS operating band unwanted emission mask (UEM) for BC1, BS maximum output power  $31 < P \leq 38 \text{ dBm}$ 

Frequency offset of measurement filter -3dB point, $\Delta f$	Frequency offset of measurement filter centre frequency, $f_{\text{offset}}$	Minimum requirement (Note 1, Note 2)	Measurement bandwidth (Note 4)
$0 \text{ MHz} \leq \Delta f < 0.6 \text{ MHz}$	$0.015 \text{ MHz} \leq f_{\text{offset}} < 0.615 \text{ MHz}$	$P - 58 \text{ dB} - \frac{5}{3} \left( \frac{f_{\text{offset}}}{\text{MHz}} - 0.015 \right) \text{ dB}$	30 kHz
$0.6 \text{ MHz} \leq \Delta f < 1 \text{ MHz}$	$0.615 \text{ MHz} \leq f_{\text{offset}} < 1.015 \text{ MHz}$	$P - 53 \text{ dB} - 15 \cdot \left( \frac{f_{\text{offset}}}{\text{MHz}} - 0.215 \right) \text{ dB}$	30 kHz
(Note 3)	$1.015 \text{ MHz} \leq f_{\text{offset}} < 1.5 \text{ MHz}$	P - 65 dB	30 kHz
$1 \text{ MHz} \leq \Delta f \leq 2.6 \text{ MHz}$	$1.5 \text{ MHz} \leq f_{\text{offset}} < 3.1 \text{ MHz}$	P - 52 dB	1 MHz
$2.6 \text{ MHz} \leq \Delta f \leq 5 \text{ MHz}$	$3.1 \text{ MHz} \leq f_{\text{offset}} < 5.5 \text{ MHz}$	$\min(P - 52 \text{ dB}, -15 \text{ dBm})$	1 MHz
$5 \text{ MHz} \leq \Delta f \leq \Delta f_{\text{max}}$	$5.5 \text{ MHz} \leq f_{\text{offset}} < f_{\text{offset}_{\text{max}}}$	P - 56 dB	1 MHz
NOTE 1: For MSR BS supporting non-contiguous spectrum operation within any operating band the minimum requirement within sub-block gaps is calculated as a cumulative sum of contributions from adjacent sub blocks on each side of the sub block gap. Exception is $\Delta f \geq 10 \text{ MHz}$ from both adjacent sub-blocks on each side of the sub-block gap, where the minimum requirement within sub-block gaps shall be P - 56 dB /MHz.			
NOTE 2: For MSR BS supporting multi-band operation with inter RF bandwidth gap < 20MHz the minimum requirement within the inter RF bandwidth gaps is calculated as a cumulative sum of contributions from adjacent sub-blocks on each side of the inter RF bandwidth gap.			

**Table 6.6.2.1-3: Medium Range BS operating band unwanted emission mask (UEM) for BC1, BS maximum output power  $P \leq 31$  dBm**

Frequency offset of measurement filter -3dB point, $\Delta f$	Frequency offset of measurement filter centre frequency, $f_{\text{offset}}$	Minimum requirement (Note 1, Note 2)	Measurement bandwidth (Note 4)
$0 \text{ MHz} \leq \Delta f < 0.6 \text{ MHz}$	$0.015 \text{ MHz} \leq f_{\text{offset}} < 0.615 \text{ MHz}$	$-27 \text{ dBm} - \frac{5}{3} \left( \frac{f_{\text{offset}}}{\text{MHz}} - 0.015 \right) \text{ dB}$	30 kHz
$0.6 \text{ MHz} \leq \Delta f < 1 \text{ MHz}$	$0.615 \text{ MHz} \leq f_{\text{offset}} < 1.015 \text{ MHz}$	$-22 \text{ dBm} - 15 \cdot \left( \frac{f_{\text{offset}}}{\text{MHz}} - 0.215 \right) \text{ dB}$	30 kHz
(Note 3)	$1.015 \text{ MHz} \leq f_{\text{offset}} < 1.5 \text{ MHz}$	-34 dBm	30 kHz
$1 \text{ MHz} \leq \Delta f \leq 5 \text{ MHz}$	$1.5 \text{ MHz} \leq f_{\text{offset}} < 5.5 \text{ MHz}$	-21 dBm	1 MHz
$5 \text{ MHz} \leq \Delta f \leq \Delta f_{\text{max}}$	$5.5 \text{ MHz} \leq f_{\text{offset}} < f_{\text{offset}_{\text{max}}}$	-25 dBm	1 MHz
NOTE 1: For MSR BS supporting non-contiguous spectrum operation within any operating band the minimum requirement within sub-block gaps is calculated as a cumulative sum of contributions from adjacent sub blocks on each side of the sub block gap. Exception is $\Delta f \geq 10 \text{ MHz}$ from both adjacent sub-blocks on each side of the sub-block gap, where the minimum requirement within sub-block gaps shall be $P - 56 \text{ dB/MHz}$ .			
NOTE 2: For MSR BS supporting multi-band operation with inter RF bandwidth gap $< 20 \text{ MHz}$ the minimum requirement within the inter RF bandwidth gaps is calculated as a cumulative sum of contributions from adjacent sub-blocks on each side of the inter RF bandwidth gap.			

**Table 6.6.2.1-4: Local Area operating band unwanted emission mask (UEM) for BC1**

Frequency offset of measurement filter -3dB point, $\Delta f$	Frequency offset of measurement filter centre frequency, $f_{\text{offset}}$	Minimum requirement (Note 1, Note 2)	Measurement bandwidth (Note 4)
$0 \text{ MHz} \leq \Delta f < 5 \text{ MHz}$	$0.05 \text{ MHz} \leq f_{\text{offset}} < 5.05 \text{ MHz}$	$-30 \text{ dBm} - \frac{7}{5} \left( \frac{f_{\text{offset}}}{\text{MHz}} - 0.05 \right) \text{ dB}$	100 kHz
$5 \text{ MHz} \leq \Delta f < \min(10 \text{ MHz}, \Delta f_{\text{max}})$	$5.05 \text{ MHz} \leq f_{\text{offset}} < \min(10.05 \text{ MHz}, f_{\text{offset}_{\text{max}}})$	-37 dBm	100 kHz
$10 \text{ MHz} \leq \Delta f \leq \Delta f_{\text{max}}$	$10.05 \text{ MHz} \leq f_{\text{offset}} < f_{\text{offset}_{\text{max}}}$	-37 dBm (Note 5)	100 kHz
NOTE 1: For MSR BS supporting non-contiguous spectrum operation within any operating band the minimum requirement within sub-block gaps is calculated as a cumulative sum of contributions from adjacent sub blocks on each side of the sub block gap. Exception is $\Delta f \geq 10 \text{ MHz}$ from both adjacent sub blocks on each side of the sub-block gap, where the minimum requirement within sub-block gaps shall be $-37 \text{ dBm/MHz}$ .			
NOTE 2: For MSR BS supporting multi-band operation with inter RF bandwidth gap $< 20 \text{ MHz}$ the minimum requirement within the inter RF bandwidth gaps is calculated as a cumulative sum of contributions from adjacent sub-blocks on each side of the inter RF bandwidth gap.			

NOTE 3: This frequency range ensures that the range of values of  $f_{\text{offset}}$  is continuous.

NOTE 4: As a general rule for the requirements in the present subclause, the resolution bandwidth of the measuring equipment should be equal to the measurement bandwidth. However, to improve measurement accuracy, sensitivity and efficiency, the resolution bandwidth may be smaller than the measurement bandwidth. When the resolution bandwidth is smaller than the measurement bandwidth, the result should be integrated over the measurement bandwidth in order to obtain the equivalent noise bandwidth of the measurement bandwidth.

NOTE 5: The requirement is not applicable when  $\Delta f_{\text{max}} < 10 \text{ MHz}$ .



### 6.6.2.2 General minimum requirement for Band Category 2

For a BS operating in Band Category 2 the requirement applies outside the RF bandwidth edges. In addition, for a BS operating in non-contiguous spectrum, it applies inside any sub-block gap.

Outside the RF bandwidth edges, emissions shall not exceed the maximum levels specified in Tables 6.6.2.2-1 to 6.6.2.2-8 below, where:

- $\Delta f$  is the separation between the RF bandwidth edge frequency and the nominal -3dB point of the measuring filter closest to the carrier frequency.
- $f_{\text{offset}}$  is the separation between the RF bandwidth edge frequency and the centre of the measuring filter.
- $f_{\text{offset}_{\text{max}}}$  is the offset to the frequency 10 MHz outside the downlink operating band.
- $\Delta f_{\text{max}}$  is equal to  $f_{\text{offset}_{\text{max}}}$  minus half of the bandwidth of the measuring filter.

For a BS operating in multiple bands, inside any inter-RF bandwidth gaps with  $W_{\text{gap}} < 20$  MHz, emissions shall not exceed the cumulative sum of the minimum requirements specified at the RF bandwidth edges on each side of the inter-RF bandwidth gap. The minimum requirement for RF bandwidth edge is specified in Table 6.6.2.2-1 to 6.6.2.2-8 below, where in this case:

- $\Delta f$  is the separation between the RF bandwidth edge frequency and the nominal -3 dB point of the measuring filter closest to the carrier frequency.
- $f_{\text{offset}}$  is the separation between the RF bandwidth edge frequency and the centre of the measuring filter.
- $f_{\text{offset}_{\text{max}}}$  is equal to the inter RF bandwidth gap divided by two.
- $\Delta f_{\text{max}}$  is equal to  $f_{\text{offset}_{\text{max}}}$  minus half of the bandwidth of the measuring filter.

Inside any sub-block gap for a BS operating in non-contiguous spectrum, emissions shall not exceed the cumulative sum of the minimum requirement specified for the adjacent sub blocks on each side of the sub block gap. The minimum requirement for each sub block is specified in Tables 6.6.2.2-1 to 6.6.2.2-8 below, where in this case:

- $\Delta f$  is the separation between the sub block edge frequency and the nominal -3 dB point of the measuring filter closest to the sub block edge.
- $f_{\text{offset}}$  is the separation between the sub block edge frequency and the centre of the measuring filter.
- $f_{\text{offset}_{\text{max}}}$  is equal to the sub block gap bandwidth divided by two.
- $\Delta f_{\text{max}}$  is equal to  $f_{\text{offset}_{\text{max}}}$  minus half of the bandwidth of the measuring filter.

Table 6.6.2.2-1: Wide Area operating band unwanted emission mask (UEM) for BC2

Frequency offset of measurement filter -3dB point, $\Delta f$	Frequency offset of measurement filter centre frequency, $f_{\text{offset}}$	Minimum requirement (Note 2) (Note 3)	Measurement bandwidth (Note 10)
$0 \text{ MHz} \leq \Delta f < 0.2 \text{ MHz}$ (Note 1)	$0.015 \text{ MHz} \leq f_{\text{offset}} < 0.215 \text{ MHz}$	-14 dBm	30 kHz
$0.2 \text{ MHz} \leq \Delta f < 1 \text{ MHz}$	$0.215 \text{ MHz} \leq f_{\text{offset}} < 1.015 \text{ MHz}$	$-14 \text{ dBm} - 15 \cdot \left( \frac{f_{\text{offset}}}{\text{MHz}} - 0.215 \right) \text{ dB}$	30 kHz
(Note 9)	$1.015 \text{ MHz} \leq f_{\text{offset}} < 1.5 \text{ MHz}$	-26 dBm	30 kHz
$1 \text{ MHz} \leq \Delta f \leq \min(\Delta f_{\text{max}}, 10 \text{ MHz})$	$1.5 \text{ MHz} \leq f_{\text{offset}} < \min(f_{\text{offset}_{\text{max}}}, 10.5 \text{ MHz})$	-13 dBm	1 MHz
$10 \text{ MHz} \leq \Delta f \leq \Delta f_{\text{max}}$	$10.5 \text{ MHz} \leq f_{\text{offset}} < f_{\text{offset}_{\text{max}}}$	-15 dBm (Note 11)	1 MHz
NOTE 1: For operation with a GSM/EDGE or an E-UTRA 1.4 or 3 MHz carrier adjacent to the RF bandwidth edge, the limits in Table 6.6.2.2-2 apply for $0 \text{ MHz} \leq \Delta f < 0.15 \text{ MHz}$ .			
NOTE 2: For MSR BS supporting non-contiguous spectrum operation within any operating band the minimum requirement within sub-block gaps is calculated as a cumulative sum of contributions from adjacent sub-blocks on each side of the sub-block gap. Exception is $\Delta f \geq 10 \text{ MHz}$ from both adjacent sub-blocks on each side of the sub-block gap, where the minimum requirement within sub-block gaps shall be -15dBm/MHz.			
NOTE 3: For MSR BS supporting multi-band operation with inter RF bandwidth gap < 20MHz operation the minimum requirement within the inter RF bandwidth gaps is calculated as a cumulative sum of contributions from adjacent sub-blocks on each side of the inter RF bandwidth gap.			

Table 6.6.2.2-2: Wide Area operating band unwanted emission limits for operation in BC2 with GSM/EDGE or E-UTRA 1.4 or 3 MHz carriers adjacent to the RF bandwidth edge

Frequency offset of measurement filter -3dB point, $\Delta f$	Frequency offset of measurement filter centre frequency, $f_{\text{offset}}$	Minimum requirement (Note 5, 6, 7)	Measurement bandwidth (Note 10)
$0 \text{ MHz} \leq \Delta f < 0.05 \text{ MHz}$	$0.015 \text{ MHz} \leq f_{\text{offset}} < 0.065 \text{ MHz}$	$\text{Max}(5 \text{ dBm} - 60 \cdot \left( \frac{f_{\text{offset}}}{\text{MHz}} - 0.015 \right) \text{ dB} + X, -14 \text{ dBm})$	30 kHz
$0.05 \text{ MHz} \leq \Delta f < 0.15 \text{ MHz}$	$0.065 \text{ MHz} \leq f_{\text{offset}} < 0.165 \text{ MHz}$	$\text{Max}(2 \text{ dBm} - 160 \cdot \left( \frac{f_{\text{offset}}}{\text{MHz}} - 0.065 \right) \text{ dB} + X, -14 \text{ dBm})$	30 kHz
NOTE 4: The limits in this table only apply for operation with a GSM/EDGE or an E-UTRA 1.4 or 3 MHz carrier adjacent to the RF bandwidth edge.			
NOTE 5: For MSR BS supporting non-contiguous spectrum operation within any operating band the minimum requirement within sub-block gaps is calculated as a cumulative sum of contributions from adjacent sub blocks on each side of the sub block gap.			
NOTE 6: For MSR BS supporting multi-band operation with inter RF bandwidth gap < 20MHz the minimum requirement within the inter RF bandwidth gaps is calculated as a cumulative sum of contributions from adjacent sub-blocks on each side of the inter RF bandwidth gap.			
NOTE 7: In case the carrier adjacent to the RF bandwidth edge is a GSM/EDGE carrier, the value of $X = P_{\text{GSMcarrier}} - 43$ , where $P_{\text{GSMcarrier}}$ is the power level of the GSM/EDGE carrier adjacent to the RF bandwidth edge. In other cases, $X = 0$ .			

**Table 6.6.2-3: Medium Range BS operating band unwanted emission mask (UEM) for BC2, BS maximum output power  $31 < P \leq 38$  dBm**

Frequency offset of measurement filter -3dB point, $\Delta f$	Frequency offset of measurement filter centre frequency, $f_{\text{offset}}$	Minimum requirement (Note 2, Note 3)	Measurement bandwidth (Note 10)
$0 \text{ MHz} \leq \Delta f < 0.6 \text{ MHz}$ (Note 1)	$0.015 \text{ MHz} \leq f_{\text{offset}} < 0.615 \text{ MHz}$	$P - 58 \text{ dB} - \frac{5}{3} \left( \frac{f_{\text{offset}}}{\text{MHz}} - 0.015 \right) \text{ dB}$	30 kHz
$0.6 \text{ MHz} \leq \Delta f < 1 \text{ MHz}$	$0.615 \text{ MHz} \leq f_{\text{offset}} < 1.015 \text{ MHz}$	$P - 53 \text{ dB} - 15 \cdot \left( \frac{f_{\text{offset}}}{\text{MHz}} - 0.215 \right) \text{ dB}$	30 kHz
(Note 9)	$1.015 \text{ MHz} \leq f_{\text{offset}} < 1.5 \text{ MHz}$	P - 65 dB	30 kHz
$1 \text{ MHz} \leq \Delta f \leq 2.8 \text{ MHz}$	$1.5 \text{ MHz} \leq f_{\text{offset}} < 3.3 \text{ MHz}$	P - 52 dB	1 MHz
$2.8 \text{ MHz} \leq \Delta f \leq 5 \text{ MHz}$	$3.3 \text{ MHz} \leq f_{\text{offset}} < 5.5 \text{ MHz}$	min(P - 52 dB, -15dBm)	1 MHz
$5 \text{ MHz} \leq \Delta f \leq \Delta f_{\text{max}}$	$5.5 \text{ MHz} \leq f_{\text{offset}} < f_{\text{offset}_{\text{max}}}$	P - 56 dB	1 MHz
<p>NOTE 1: For operation with a GSM/EDGE or an E-UTRA 1.4 or 3 MHz carrier adjacent to the RF bandwidth edge, the limits in Table 6.6.2-5 apply for <math>0 \text{ MHz} \leq \Delta f &lt; 0.15 \text{ MHz}</math>.</p> <p>NOTE 2: For MSR BS supporting non-contiguous spectrum operation within any operating band the minimum requirement within sub-block gaps is calculated as a cumulative sum of contributions from adjacent sub blocks on each side of the sub block gap. Exception is <math>\Delta f \geq 10 \text{ MHz}</math> from both adjacent sub-blocks on each side of the sub-block gap, where the minimum requirement within sub-block gaps shall be (P - 56 dB)/MHz.</p> <p>NOTE 3: For MSR BS supporting multi-band operation with inter RF bandwidth gap &lt; 20MHz the minimum requirement within the inter RF bandwidth gaps is calculated as a cumulative sum of contributions from adjacent sub-blocks on each side of the inter RF bandwidth gap.</p>			

**Table 6.6.2-4: Medium Range BS operating band unwanted emission mask (UEM) for BC2, BS maximum output power  $P \leq 31$  dBm**

Frequency offset of measurement filter -3dB point, $\Delta f$	Frequency offset of measurement filter centre frequency, $f_{\text{offset}}$	Minimum requirement (Note 2, Note 3)	Measurement bandwidth (Note 10)
$0 \text{ MHz} \leq \Delta f < 0.6 \text{ MHz}$ (Note 1)	$0.015 \text{ MHz} \leq f_{\text{offset}} < 0.615 \text{ MHz}$	$-27 \text{ dBm} - \frac{5}{3} \left( \frac{f_{\text{offset}}}{\text{MHz}} - 0.015 \right) \text{ dB}$	30 kHz
$0.6 \text{ MHz} \leq \Delta f < 1 \text{ MHz}$	$0.615 \text{ MHz} \leq f_{\text{offset}} < 1.015 \text{ MHz}$	$-22 \text{ dBm} - 15 \cdot \left( \frac{f_{\text{offset}}}{\text{MHz}} - 0.215 \right) \text{ dB}$	30 kHz
(Note 9)	$1.015 \text{ MHz} \leq f_{\text{offset}} < 1.5 \text{ MHz}$	-34 dBm	30 kHz
$1 \text{ MHz} \leq \Delta f \leq 5 \text{ MHz}$	$1.5 \text{ MHz} \leq f_{\text{offset}} < 5.5 \text{ MHz}$	-21 dBm	1 MHz
$5 \text{ MHz} \leq \Delta f \leq \Delta f_{\text{max}}$	$5.5 \text{ MHz} \leq f_{\text{offset}} < f_{\text{offset}_{\text{max}}}$	-25 dBm	1 MHz
NOTE 1: For operation with a GSM/EDGE or an E-UTRA 1.4 or 3 MHz carrier adjacent to the RF bandwidth edge, the limits in Table 6.6.2.2-6 apply for $0 \text{ MHz} \leq \Delta f < 0.15 \text{ MHz}$ .			
NOTE 2: For MSR BS supporting non-contiguous spectrum operation within any operating band the minimum requirement within sub-block gaps is calculated as a cumulative sum of contributions from adjacent sub blocks on each side of the sub block gap. Exception is $\Delta f \geq 10 \text{ MHz}$ from both adjacent sub-blocks on each side of the sub-block gap, where the minimum requirement within sub-block gaps shall be -25dBm/MHz.			
NOTE 3: For MSR BS supporting multi-band operation with inter RF bandwidth gap < 20MHz the minimum requirement within the inter RF bandwidth gaps is calculated as a cumulative sum of contributions from adjacent sub-blocks on each side of the inter RF bandwidth gap.			

**Table 6.6.2-5: Medium Range operating band unwanted emission limits for operation in BC2 with GSM/EDGE or E-UTRA 1.4 or 3 MHz carriers adjacent to the RF bandwidth edge, BS maximum output power  $31 < P \leq 38$  dBm**

Frequency offset of measurement filter -3dB point, $\Delta f$	Frequency offset of measurement filter centre frequency, $f_{\text{offset}}$	Minimum requirement (Note 5, 6)	Measurement bandwidth (Note 10)
$0 \text{ MHz} \leq \Delta f < 0.05 \text{ MHz}$	$0.015 \text{ MHz} \leq f_{\text{offset}} < 0.065 \text{ MHz}$	$P - 38 \text{ dB} - 60 \cdot \left( \frac{f_{\text{offset}}}{\text{MHz}} - 0.015 \right) \text{ dB}$	30 kHz
$0.05 \text{ MHz} \leq \Delta f < 0.15 \text{ MHz}$	$0.065 \text{ MHz} \leq f_{\text{offset}} < 0.165 \text{ MHz}$	$P - 41 \text{ dB} - 160 \cdot \left( \frac{f_{\text{offset}}}{\text{MHz}} - 0.065 \right) \text{ dB}$	30 kHz
NOTE 4: The limits in this table only apply for operation with a GSM/EDGE or an E-UTRA 1.4 or 3 MHz carrier adjacent to the RF bandwidth edge.			
NOTE 5: For MSR BS supporting non-contiguous spectrum operation within any operating band the minimum requirement within sub-block gaps is calculated as a cumulative sum of contributions from adjacent sub blocks on each side of the sub block gap.			
NOTE 6: For MSR BS supporting multi-band operation with inter RF bandwidth gap < 20MHz the minimum requirement within the inter RF bandwidth gaps is calculated as a cumulative sum of contributions from adjacent sub-blocks on each side of the inter RF bandwidth gap.			

**Table 6.6.2.2-6: Medium Range operating band unwanted emission limits for operation in BC2 with GSM/EDGE or E-UTRA 1.4 or 3 MHz carriers adjacent to the RF bandwidth edge, BS maximum output power  $P \leq 31$  dBm**

Frequency offset of measurement filter -3dB point, $\Delta f$	Frequency offset of measurement filter centre frequency, $f_{\text{offset}}$	Minimum requirement (Note 5, 6, 7)	Measurement bandwidth (Note 10)
$0 \text{ MHz} \leq \Delta f < 0.05 \text{ MHz}$	$0.015 \text{ MHz} \leq f_{\text{offset}} <$	$\text{Max}\left(-7 \text{ dBm} - 60 \cdot \left(\frac{f_{\text{offset}}}{\text{MHz}} - 0.015\right) \text{ dB} + X \text{ dB}, -27 \text{ dBm}\right)$	30 kHz
$0.05 \text{ MHz} \leq \Delta f < 0.15 \text{ MHz}$	$0.065 \text{ MHz} \leq f_{\text{offset}} < 0.165 \text{ MHz}$	$\text{Max}\left(-10 \text{ dBm} - 160 \cdot \left(\frac{f_{\text{offset}}}{\text{MHz}} - 0.065\right) \text{ dB} + X \text{ dB}, -27 \text{ dBm}\right)$	30 kHz
<p>NOTE 4: The limits in this table only apply for operation with a GSM/EDGE or an E-UTRA 1.4 or 3 MHz carrier adjacent to the RF bandwidth edge.</p> <p>NOTE 5: For MSR BS supporting non-contiguous spectrum operation within any operating band the minimum requirement within sub-block gaps is calculated as a cumulative sum of contributions from adjacent sub blocks on each side of the sub block gap.</p> <p>NOTE 6: For MSR BS supporting multi-band operation with inter RF bandwidth gap &lt; 20MHz the minimum requirement within the inter RF bandwidth gaps is calculated as a cumulative sum of contributions from adjacent sub-blocks on each side of the inter RF bandwidth gap.</p> <p>NOTE 7: In case the carrier adjacent to the RF bandwidth edge is a GSM/EDGE carrier, the value of <math>X = P_{\text{GSMcarrier}} - 31</math>, where <math>P_{\text{GSMcarrier}}</math> is the power level of the GSM/EDGE carrier adjacent to the RF bandwidth edge. In other cases, <math>X = 0</math>.</p>			

**Table 6.6.2.2-7: Local Area operating band unwanted emission mask (UEM) for BC2**

Frequency offset of measurement filter -3dB point, $\Delta f$	Frequency offset of measurement filter centre frequency, $f_{\text{offset}}$	Minimum requirement (Note 2, Note 3)	Measurement bandwidth (Note 10)
$0 \text{ MHz} \leq \Delta f < 5 \text{ MHz}$ (Note 1)	$0.05 \text{ MHz} \leq f_{\text{offset}} < 5.05 \text{ MHz}$	$-30 \text{ dBm} - \frac{7}{5} \left( \frac{f_{\text{offset}}}{\text{MHz}} - 0.05 \right) \text{ dB}$	100 kHz
$5 \text{ MHz} \leq \Delta f < \min(10 \text{ MHz}, \Delta f_{\text{max}})$	$5.05 \text{ MHz} \leq f_{\text{offset}} < \min(10.05 \text{ MHz}, f_{\text{offset}_{\text{max}}})$	-37 dBm	100 kHz
$10 \text{ MHz} \leq \Delta f \leq \Delta f_{\text{max}}$	$10.05 \text{ MHz} \leq f_{\text{offset}} < f_{\text{offset}_{\text{max}}}$	-37 dBm (Note 11)	100 kHz
<p>NOTE 1: For operation with a GSM/EDGE or an E-UTRA 1.4 or 3 MHz carrier adjacent to the RF bandwidth edge, the limits in Table 6.6.2.2-8 apply for <math>0 \text{ MHz} \leq \Delta f &lt; 0.16 \text{ MHz}</math>.</p> <p>NOTE 2: For MSR BS supporting non-contiguous spectrum operation within any operating band the minimum requirement within sub-block gaps is calculated as a cumulative sum of contributions from adjacent sub blocks on each side of the sub block gap. Exception is <math>\Delta f \geq 10 \text{ MHz}</math> from both adjacent sub blocks on each side of the sub-block gap, where the minimum requirement within sub-block gaps shall be -37dBm/MHz.</p> <p>NOTE 3: For MSR BS supporting multi-band operation with inter RF bandwidth gap &lt; 20MHz the minimum requirement within the inter RF bandwidth gaps is calculated as a cumulative sum of contributions from adjacent sub-blocks on each side of the inter RF bandwidth gap.</p>			

**Table 6.6.2.2-8: Local Area operating band unwanted emission limits for operation in BC2 with GSM/EDGE or E-UTRA 1.4 or 3 MHz carriers adjacent to the RF bandwidth edge**

Frequency offset of measurement filter -3dB point, $\Delta f$	Frequency offset of measurement filter centre frequency, $f_{\text{offset}}$	Minimum requirement (Note 5, 6,7)	Measurement bandwidth (Note 10)
$0 \text{ MHz} \leq \Delta f < 0.05 \text{ MHz}$	$0.015 \text{ MHz} \leq f_{\text{offset}} < 0.065 \text{ MHz}$	$\text{Max}\left(-14\text{dBm} - 60 \cdot \left(\frac{f_{\text{offset}}}{\text{MHz}} - 0.015\right) \text{dB} + X\text{dB}, -35\text{dBm}\right)$	30 kHz
$0.05 \text{ MHz} \leq \Delta f < 0.16 \text{ MHz}$	$0.065 \text{ MHz} \leq f_{\text{offset}} < 0.175 \text{ MHz}$	$\text{Max}\left(-17\text{dBm} - 160 \cdot \left(\frac{f_{\text{offset}}}{\text{MHz}} - 0.065\right) \text{dB} + X\text{dB}, -35\text{dBm}\right)$	30 kHz
<p>NOTE 4: The limits in this table only apply for operation with a GSM/EDGE or an E-UTRA 1.4 or 3 MHz carrier adjacent to the RF bandwidth edge.</p> <p>NOTE 5: For MSR BS supporting non-contiguous spectrum operation within any operating band the minimum requirement within sub-block gaps is calculated as a cumulative sum of contributions from adjacent sub blocks on each side of the sub block gap.</p> <p>NOTE 6: For MSR BS supporting multi-band operation with inter RF bandwidth gap &lt; 20MHz the minimum requirement within the inter RF bandwidth gaps is calculated as a cumulative sum of contributions from adjacent sub-blocks on each side of the inter RF bandwidth gap.</p> <p>NOTE 7: In case the carrier adjacent to the RF bandwidth edge is a GSM/EDGE carrier, the value of <math>X = P_{\text{GSMcarrier}} - 24</math>, where <math>P_{\text{GSMcarrier}}</math> is the power level of the GSM/EDGE carrier adjacent to the RF bandwidth edge. In other cases, <math>X = 0</math>.</p>			

NOTE 9: This frequency range ensures that the range of values of  $f_{\text{offset}}$  is continuous.

NOTE 10: As a general rule for the requirements in the present subclause, the resolution bandwidth of the measuring equipment should be equal to the measurement bandwidth. However, to improve measurement accuracy, sensitivity and efficiency, the resolution bandwidth may be smaller than the measurement bandwidth. When the resolution bandwidth is smaller than the measurement bandwidth, the result should be integrated over the measurement bandwidth in order to obtain the equivalent noise bandwidth of the measurement bandwidth.

NOTE 11: The requirement is not applicable when  $\Delta f_{\text{max}} < 10 \text{ MHz}$ .

NOTE 12: All limits in Table 6.6.2.2-1, Table 6.6.2.2-3, Table 6.6.2.2-4 and Table 6.6.2.2-7 are identical to the corresponding limits for Band Category 1 and 3.

### 6.6.2.3 GSM/EDGE single-RAT requirements

The following requirements in TS 45.005 [5] shall apply to an MSR Base Station for any operating band with GSM/EDGE single RAT operation in Band Category 2:

- Spectrum due to the modulation and wide band noise, applicable parts of subclause 4.2.1.1, 4.2.1.2, 4.2.1.3-a2, 4.2.1.3-b2, 4.2.1.3-c2 and 4.2.1.4.2.
- Spectrum due to switching transients, applicable parts of subclause 4.2.2.1-b.
- Emission requirement for frequency offsets of between 2 and 10 MHz outside relevant transmit band, applicable parts of subclause 4.3.1 and 4.3.2.1.
- Intra BTS Intermodulation, applicable parts of subclause 4.7.2, 4.7.2.1-b, 4.7.2.3-b and 4.7.2.3-c.

## 6.6.2.4 Additional requirements

### 6.6.2.4.1 Limits in FCC Title 47

In addition to the requirements in subclauses 6.6.2.1 and 6.6.2.2, the BS may have to comply with the applicable emission limits established by FCC Title 47 [8], when deployed in regions where those limits are applied, and under the conditions declared by the manufacturer.

### 6.6.2.4.2 Unsynchronized operation for BC3

In certain regions, the following requirements may apply to a TDD BS operating in BC3 in the same geographic area and in the same operating band as another TDD system without synchronisation. For this case the emissions shall not exceed -52 dBm/MHz in each supported downlink operating band except in:

- The frequency range from 10 MHz below the lower RF bandwidth edge to the frequency 10 MHz above the upper RF bandwidth edge of each supported band.

NOTE 1: Local or regional regulations may specify another excluded frequency range, which may include frequencies where synchronised TDD systems operate.

NOTE 2: TDD base stations that are synchronized and operating in BC3 can transmit without these additional co-existence requirements.

### 6.6.2.4.3 Protection of DTT

In certain regions the following requirement may apply for protection of DTT. For a BS operating in Band 20, the level of emissions in the band 470-790 MHz, measured in an 8 MHz filter bandwidth on centre frequencies  $F_{\text{filter}}$  according to Table 6.6.2.4.3-1, shall not exceed the maximum emission level  $P_{\text{EM,N}}$  declared by the manufacturer. This requirement applies in the frequency range 470-790 MHz even though part of the range falls in the spurious domain.

**Table 6.6.2.4.3-1: Declared emissions levels for protection of DTT**

Filter centre frequency, $F_{\text{filter}}$	Measurement bandwidth	Declared emission level [dBm]
$F_{\text{filter}} = 8 \cdot N + 306$ (MHz); $21 \leq N \leq 60$	8 MHz	$P_{\text{EM,N}}$

Note: The regional requirement is defined in terms of EIRP (effective isotropic radiated power), which is dependent on both the BS emissions at the antenna connector and the deployment (including antenna gain and feeder loss). The requirement defined above provides the characteristics of the base station needed to verify compliance with the regional requirement. Compliance with the regional requirement can be determined using the method outlined in Annex G of TS 36.104 [4].

### 6.6.2.4.4 Co-existence with services in adjacent frequency bands

This requirement may be applied for the protection of systems operating in frequency bands adjacent to Band 1 as defined in clause 4.5, in geographic areas in which both an adjacent band service and UTRA and/or E-UTRA are deployed.

The power of any spurious emission shall not exceed:

**Table 6.6.2.4.4-1: Emissions limits for protection of adjacent band services**

Operating Band	Frequency range	Maximum Level	Measurement Bandwidth
1	2100-2105 MHz	$-30 + 3.4 \cdot (f - 2100 \text{ MHz})$ dBm	1 MHz
	2175-2180 MHz	$-30 + 3.4 \cdot (2180 \text{ MHz} - f)$ dBm	1 MHz

#### 6.6.2.4.5 Co-existence with RNSS/GPS services in North America

In regions where FCC regulation applies, requirements for protection of GPS according to FCC Order DA 10-534 applies for operation in Band 24. The following normative requirement covers the base station, to be used together with other information about the site installation to verify compliance with the requirement in FCC Order DA 10-534. The requirement applies to BS operating in Band 24 to ensure that appropriate interference protection is provided to the 1559 – 1610 MHz band. This requirement applies to the frequency range 1559-1610 MHz.

The level of emissions in the 1559 – 1610 MHz band, measured in measurement bandwidth according to Table 6.6.2.4.5-1 shall not exceed the maximum emission levels  $P_{E\_1MHz}$  and  $P_{E\_1kHz}$  declared by the manufacturer.

**Table 6.6.2.4.5-1: Declared emissions levels for protection of the 1559-1610 MHz band**

Operating Band	Frequency range	Declared emission level [dBW] (Measurement bandwidth = 1 MHz)	Declared emission level [dBW] of discrete emissions of less than 700 Hz bandwidth (Measurement bandwidth = 1 kHz)
24	1559 - 1610 MHz	$P_{E\_1MHz}$	$P_{E\_1kHz}$

Note: The regional requirement in FCC Order DA 10-534 is defined in terms of EIRP (effective isotropic radiated power), which is dependent on both the BS emissions at the antenna connector and the deployment (including antenna gain and feeder loss). The EIRP level is calculated using:  $P_{EIRP} = P_E + G_{ant}$  where  $P_E$  denotes the BS unwanted emission level at the antenna connector,  $G_{ant}$  equals the BS antenna gain minus feeder loss. The requirement defined above provides the characteristics of the base station needed to verify compliance with the regional requirement.

#### 6.6.2.4.6 Additional requirements for band 41

The following requirement may apply to BS operating in Band 41 in certain regions. Emissions shall not exceed the maximum levels specified in Table 6.6.2.4.6-1 below, where:

- $\Delta f$  is the separation between the RF bandwidth edge frequency and the nominal -3dB point of the measuring filter closest to the carrier frequency.
- $f_{offset}$  is the separation between the RF bandwidth edge frequency and the centre of the measuring filter.

**Table 6.6.2.4.6-1: Additional operating band unwanted emission limits for Band 41**

Channel bandwidth	Frequency offset of measurement filter -3dB point, $\Delta f$	Frequency offset of measurement filter centre frequency, $f_{offset}$	Minimum requirement	Measurement bandwidth
10 MHz	$10 \text{ MHz} \leq \Delta f < 20 \text{ MHz}$	$10.5 \text{ MHz} \leq f_{offset} < 19.5 \text{ MHz}$	-22 dBm	1 MHz
20 MHz	$20 \text{ MHz} \leq \Delta f < 40 \text{ MHz}$	$20.5 \text{ MHz} \leq f_{offset} < 39.5 \text{ MHz}$	-22 dBm	1 MHz
NOTE: This requirement applies for E-UTRA carriers allocated within 2545-2575MHz.				

### 6.6.3 Occupied bandwidth

The occupied bandwidth is the width of a frequency band such that, below the lower and above the upper frequency limits, the mean powers emitted are each equal to a specified percentage  $\beta/2$  of the total mean transmitted power. See also ITU-R Recommendation SM.328 [11].

The value of  $\beta/2$  shall be taken as 0.5%.

The requirement in the present clause applies during the transmitter ON period for a single transmitted carrier. In addition, for E-UTRA intra-band contiguous carrier aggregation, the requirement in clause 6.6.1 of TS 36.104 [4] applies for the E-UTRA component carriers that are aggregated. The minimum requirement below may be applied regionally. There may also be regional requirements to declare the occupied bandwidth according to the definition in the present clause.



### 6.6.3.1 Minimum requirement

The occupied bandwidth shall be less than values listed in Table 6.6.3.1-1.

**Table 6.6.3.1-1: Occupied bandwidth**

RAT	Occupied bandwidth limit
E-UTRA	$BW_{\text{channel}}$
UTRA FDD	5 MHz
1.28 Mcps UTRA TDD	1.6 MHz

## 6.6.4 Adjacent Channel Leakage power Ratio (ACLR)

Adjacent Channel Leakage power Ratio (ACLR) is the ratio of the filtered mean power centred on the assigned channel frequency to the filtered mean power centred on an adjacent channel frequency.

### 6.6.4.1 E-UTRA minimum requirement

For E-UTRA, the minimum requirement for ACLR is specified in TS 36.104 [4], subclause 6.6.2, and applies outside the RF bandwidth edges.

In addition inside any sub-block gap with a sub-block gap size  $W_{\text{gap}} \geq 15$  MHz and  $W_{\text{gap}} \geq 20$  MHz for a BS operating in non-contiguous spectrum, the ACLR requirement for the first and second adjacent channels, respectively, in TS 36.104 [4] subclause 6.6.2 applies.

For a BS operating in non-contiguous spectrum the CA ACLR requirement in subclause 6.6.4.4 applies in sub block gaps for the frequency ranges defined in Table 6.6.4.4-1.

For a BS operating in multiple bands, where multiple bands are mapped on the same antenna connector, the CA ACLR requirement in subclause 6.6.4.4 applies in inter-RF bandwidth gaps for the frequency ranges defined in Table 6.6.4.4-1.

### 6.6.4.2 UTRA FDD minimum requirement

For UTRA FDD, the minimum requirement for ACLR is specified in TS 25.104 [2], subclause 6.6.2.2, and applies outside the RF bandwidth edges.

In addition inside any sub-block gap with a sub-block gap size  $W_{\text{gap}} \geq 15$  MHz and  $W_{\text{gap}} \geq 20$  MHz for a BS operating in non-contiguous spectrum, the ACLR requirement for the first and second adjacent channels, respectively, in TS 25.104 [2] subclause 6.6.2.2 applies.

For a BS operating in non-contiguous spectrum the CA ACLR requirement in subclause 6.6.4.4 applies in sub block gaps for the frequency ranges defined in Table 6.6.4.4-1.

For a BS operating in multiple bands, where multiple bands are mapped on the same antenna connector, the CA ACLR requirement in subclause 6.6.4.4 applies in inter-RF bandwidth gaps for the frequency ranges defined in Table 6.6.4.4-1.

### 6.6.4.3 UTRA TDD minimum requirement

For UTRA TDD, the minimum requirement for ACLR is specified in TS 25.105 [3], subclause 6.6.2.2.1.2, and applies outside the RF bandwidth edges.

### 6.6.4.4 Cumulative ACLR requirement in non-contiguous spectrum

The following requirement applies for the gap sizes listed in Table 6.6.4.4-1:

- Inside a sub-block gap within an operating band for a BS operating in non-contiguous spectrum.
- Inside an inter RF bandwidth gap for a BS operating in multiple bands, where multiple bands are mapped on the same antenna connector.

The Cumulative Adjacent Channel Leakage power Ratio (CA ACLR) in a sub-block gap is the ratio of

- a) the sum of the filtered mean power centred on the assigned channel frequencies for the two carriers adjacent to each side of the sub-block gap or the inter RF bandwidth gap, and
- b) the filtered mean power centred on a frequency channel adjacent to one of the respective sub-block edges or RF bandwidth edges.

The requirement applies to adjacent channels of E-UTRA or UTRA carriers allocated adjacent to each side of the sub-block gap or the inter RF bandwidth gap. The assumed filter for the adjacent channel frequency is defined in Table 6.6.4.4-1 and the filters on the assigned channels are defined in Table 6.6.4.4-2.

NOTE: If the RAT on the assigned channel frequencies are different, the filters used are also different.

For Wide Area Category A BS, either the CA CLR limits in Table 6.6.4.4-1 or the absolute limit of -13dBm/MHz apply, whichever is less stringent.

For Wide Area Category B BS, either the CA CLR limits in Table 6.6.4.4-1 or the absolute limit of -15dBm/MHz apply, whichever is less stringent.

For Medium Range BS, either the CA CLR limits in Table 6.6.4.4-1 or the absolute limit of -25 dBm/MHz shall apply, whichever is less stringent.

For Local Area BS, either the CA CLR limits in Table 6.6.4.4-1 or the absolute limit of -32 dBm/MHz shall apply, whichever is less stringent.

The CA CLR for E-UTRA and UTRA carriers located on either side of the sub-block gap or the inter RF bandwidth gap shall be higher than the value specified in Table 6.6.4.4-1.

**Table 6.6.4.4-1: Base Station CA CLR in non-contiguous spectrum**

Band Category	Gap size ( $W_{\text{gap}}$ ) where the limit applies	BS adjacent channel centre frequency offset below or above the sub-block edge or the RF bandwidth edge (inside the gap)	Assumed adjacent channel carrier (informative)	Filter on the adjacent channel frequency and corresponding filter bandwidth	CA CLR limit
BC1, BC2	$5 \text{ MHz} \leq W_{\text{gap}} < 15 \text{ MHz}$	2.5 MHz	3.84 Mcps UTRA	RRC (3.84 Mcps)	45 dB
BC1, BC2	$10 \text{ MHz} < W_{\text{gap}} < 20 \text{ MHz}$	7.5 MHz	3.84 Mcps UTRA	RRC (3.84 Mcps)	45 dB
BC3	$5 \text{ MHz} \leq W_{\text{gap}} < 15 \text{ MHz}$	2.5 MHz	5MHz E-UTRA	Square ( $BW_{\text{Config}}$ )	45 dB
BC3	$10 \text{ MHz} < W_{\text{gap}} < 20 \text{ MHz}$	7.5 MHz	5MHz E-UTRA	Square ( $BW_{\text{Config}}$ )	45 dB
NOTE: The RRC filter shall be equivalent to the transmit pulse shape filter defined in TS 25.104 [2], with a chip rate as defined in this table.					

**Table 6.6.4.4-2: Filter parameters for the assigned channel**

RAT of the carrier adjacent to the sub-block gap	Filter on the assigned channel frequency and corresponding filter bandwidth
E-UTRA	E-UTRA of same BW
UTRA FDD	RRC (3.84 Mcps)
NOTE: The RRC filter shall be equivalent to the transmit pulse shape filter defined in TS 25.104 [2], with a chip rate as defined in this table.	

## 6.7 Transmitter intermodulation

The transmit intermodulation requirement is a measure of the capability of the transmitter to inhibit the generation of signals in its non linear elements caused by presence of the own transmit signal and an interfering signal reaching the transmitter via the antenna. The requirement applies during the transmitter ON period and the transmitter transient period. The transmitter intermodulation level is the power of the intermodulation products when an interfering signal is injected into the antenna connector.

For BS capable of multi-band operation where multiple bands are mapped on separate antenna connectors, the single-band requirements apply regardless of the interfering signals position relative to the inter-RF bandwidth gap.

### 6.7.1 General minimum requirement

The transmitter intermodulation level shall not exceed the unwanted emission limits in subclause 6.6.1, 6.6.2, 6.6.4 in the presence of a wanted signal and an interfering signal according to Table 6.7.1-1 for BS operation in BC1, BC2 and BC3. The measurement may be limited to frequencies on which third and fifth order intermodulation products appear, considering the width of these products.

The requirement is always applicable outside the edges of the RF bandwidth. The interfering signal offset is defined relative to the RF bandwidth edges.

For BS operating in non-contiguous spectrum, the requirement is also applicable inside a sub-block gap for interfering signal offsets where the interfering signal falls completely within the sub-block gap. The interfering signal offset is defined relative to the sub-block edges.

For BS capable of multi-band operation, the requirement applies relative to the RF bandwidth edges of each operating band. In case the inter RF bandwidth gap is less than 15 MHz, the requirement in the gap applies only for interfering signal offsets where the interfering signal falls completely within the inter RF bandwidth gap.

**Table 6.7.1-1: Interfering signals for the Transmitter intermodulation requirement**

Parameter	Value
Interfering signal type	E-UTRA signal of channel bandwidth 5 MHz
Interfering signal level	Mean power level 30 dB below the mean power of the wanted signal
Interfering signal centre frequency offset from edge of the RF bandwidth or edge of sub-block inside a gap	2.5 MHz for modulated interferer 7.5 MHz for modulated interferer 12.5 MHz for modulated interferer
NOTE:	Interfering signal positions that are partially or completely outside of any downlink operating band of the base station are excluded from the requirement, unless the interfering signal positions fall within the frequency range of adjacent downlink operating bands in the same geographical area. In case that none of the interfering signal positions fall completely within the frequency range of the downlink operating band, TS 37.141 [10] provides further guidance regarding appropriate test requirements.
NOTE2:	NOTE 1 is not applied in Band 1, 3, 8, 9, 11, 18, 19, 21, 28, 34 in certain regions.

### 6.7.2 Additional minimum requirement (BC1 and BC2)

The transmitter intermodulation level shall not exceed the unwanted emission limits in subclause 6.6.1, 6.6.2, 6.6.4 in the presence of a wanted signal and an interfering signal according to Table 6.7.2-1 for BS operation in BC2. The measurement may be limited to frequencies on which third and fifth order intermodulation products appear, considering the width of these products.

The requirement is always applicable outside the edges of the RF bandwidth for BC2. The interfering signal offset is defined relative to the RF bandwidth edges.

For BS operating in non-contiguous spectrum in BC1 or BC2, the requirement is also applicable inside a sub-block gap with a gap size larger than or equal to two times the interfering signal centre frequency offset. The interfering signal offset is defined relative to the sub-block edges.

For BS capable of multi-band operation, the requirement applies relative to the RF bandwidth edges of each operating band. The requirement is also applicable inside an inter RF bandwidth gap equal or larger than two times the interfering signal centre frequency offset.

**Table 6.7.2-1: Interfering signal for the Transmitter intermodulation requirement**

Parameter	Value
Interfering signal type	CW
Interfering signal level	Mean power level 30 dB below the mean power of the wanted signal
Interfering signal centre frequency offset from edge of the RF bandwidth or edge of sub-block inside a gap	> 800 kHz for CW interferer
NOTE: Interfering signal positions that are partially or completely outside of any downlink operating band of the base station are excluded from the requirement.	

### 6.7.3 Additional minimum requirement (BC3)

The transmitter intermodulation level shall not exceed the unwanted emission limits in subclause 6.6.1, 6.6.2, 6.6.4 in the presence of a wanted signal and an interfering signal according to Table 6.7.3-1 for BS operation in BC3. The measurement may be limited to frequencies on which third and fifth order intermodulation products appear, considering the width of these products.

For BS capable of multi-band operation, the requirement applies relative to the RF bandwidth edges of each operating band. In case the inter RF bandwidth gap is less than 3.2 MHz, the requirement in the gap applies only for interfering signal offsets where the interfering signal falls completely within the inter RF bandwidth gap.

**Table 6.7.3-1: Interfering signals for the Transmitter intermodulation requirement (BC3)**

Parameter	Value
Interfering signal type	1.28Mcps UTRA TDD signal of channel bandwidth 1.6MHz
Interfering signal level	Mean power level 30 dB below the mean power of the wanted signal
Interfering signal centre frequency offset from edge of the RF bandwidth or edge of sub-block inside a gap	0.8 MHz for modulated 1.28Mcps TDD interferer 1.6 MHz for modulated 1.28Mcps TDD interferer 2.4 MHz for modulated 1.28Mcps TDD interferer
NOTE: Interfering signal positions that are partially or completely outside of any downlink operating band of the base station are excluded from the requirement.	

### 6.7.4 Additional requirements

In certain regions the following requirement may apply. For BS operating in Band 41, the transmitter intermodulation level shall not exceed the maximum levels specified in Table 6.6.2.4.6-1 in the presence of an interfering signal according to Table 6.7.4-1. The measurement may be limited to frequencies on which third and fifth order intermodulation products appear.

**Table 6.7.4-1 Interfering and wanted signals for the additional transmitter intermodulation requirement for Band 41**

Parameter	Value
Wanted signal	E-UTRA single carrier (NOTE)
Interfering signal type	E-UTRA signal of the same channel bandwidth as the wanted signal
Interfering signal level	Mean power level 30 dB below the mean power of the wanted signal
Interfering signal centre frequency offset from the lower (upper) centre of the wanted signal	$\pm BW_{\text{Channel}}$ $\pm 2 \times BW_{\text{Channel}}$
NOTE: This requirement applies for 10 or 20 MHz E-UTRA carriers allocated within 2545-2575MHz.	

## 7 Receiver characteristics

### 7.1 General

The requirements in clause 7 are expressed for a single receiver antenna connector. For receivers with antenna diversity or in case of multi-carrier reception with multiple receiver antenna connectors, the requirements apply for each receiver antenna connector.

For blocking and intermodulation characteristics, the negative offsets of the interfering signal apply relative to the assigned channel frequency of the lowest carrier frequency received and positive offsets of the interfering signal apply relative to the assigned channel frequency of the highest carrier frequency received .

A BS supporting DC-HSUPA receives two UTRA FDD cells simultaneously on adjacent carrier frequencies.

Unless otherwise stated, the receiver characteristics are specified at the BS antenna connector (test port A) with a full complement of transceivers for the configuration in normal operating conditions. For FDD operation the requirements in clause 7 shall be met with the transmitter on. If any external apparatus such as a RX amplifier, a filter or the combination of such devices is used, requirements apply at the far end antenna connector (test port B).

NOTE: In normal operating conditions the BS in FDD operation is configured to transmit and receive at the same time.. The transmitter may be off for some of the tests as specified in 37.141 [10].

Unless otherwise stated the requirements in clause 7 apply during the base station receive period.

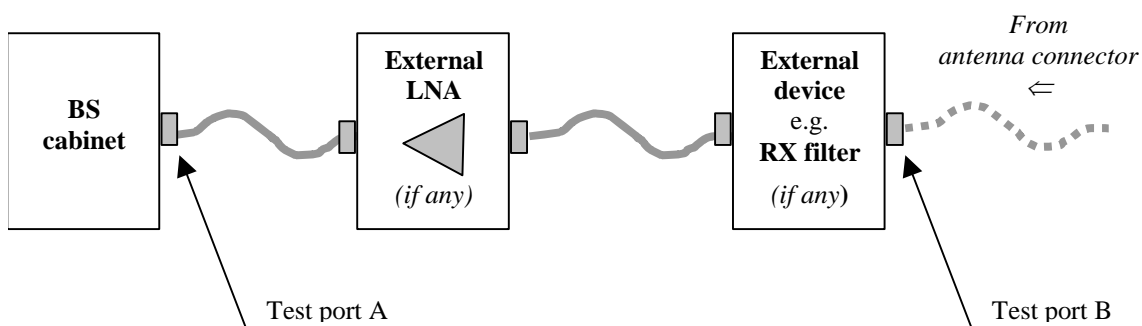

**Figure 7.1-1: Receiver test ports**

E-UTRA throughput requirements defined for the receiver characteristics in this clause do not assume HARQ retransmissions.

Values for  $F_{\text{offset,RAT}}$  to meet receiver requirements are specific for each RAT in each Band Category as specified in subclause 4.5.1 for Band Category 1, subclause 4.5.2 for Band Category 2 and subclause 4.5.3 for Band Category 3.

## 7.2 Reference sensitivity level

The reference sensitivity power level  $P_{\text{REFSENS}}$  is the minimum mean power received at the antenna connector at which a reference performance requirement shall be met for a specified reference measurement channel.

### 7.2.1 E-UTRA minimum requirement

For E-UTRA, the minimum requirement for reference sensitivity is specified in TS 36.104 [4], subclause 7.2.

### 7.2.2 UTRA FDD minimum requirement

For UTRA FDD, the minimum requirement for reference sensitivity is specified in TS 25.104 [2], subclause 7.2.

### 7.2.3 UTRA TDD minimum requirement

For UTRA TDD, the minimum requirement for reference sensitivity is specified in TS 25.105 [3], subclause 7.2.

### 7.2.4 GSM/EDGE minimum requirement

For GSM/EDGE, the minimum requirement for reference sensitivity is specified in TS 45.005 [5], applicable parts of subclause 6.2.

The conditions specified in TS 45.005 [5], Annex P.1 apply for GSM/EDGE reference sensitivity.

## 7.3 Dynamic range

The dynamic range is a measure of the capability of the receiver to receive a wanted signal in the presence of an interfering signal inside the received channel bandwidth or the capability of receiving high level of wanted signal.

### 7.3.1 E-UTRA minimum requirement

For E-UTRA, the minimum requirement for dynamic range is specified in TS 36.104 [4], subclause 7.3.

### 7.3.2 UTRA FDD minimum requirement

For UTRA FDD, the minimum requirement for dynamic range is specified in TS 25.104 [2], subclause 7.3.

### 7.3.3 UTRA TDD minimum requirement

For UTRA TDD, the minimum requirement for dynamic range is specified in TS 25.105 [3], subclause 7.3.

### 7.3.4 GSM/EDGE minimum requirement

For GSM/EDGE, the minimum requirement for dynamic range is expressed as Nominal Error Rate and is specified in TS 45.005 [5], applicable parts of subclause 6.1.1.1, 6.1.1.3, 6.1.2.2 and 6.1.3.2.

## 7.4 In-band selectivity and blocking

The in-band selectivity and blocking characteristics are measures of the receiver ability to receive a wanted signal at its assigned channel in the presence of an unwanted interferer inside the operating band and are defined by a (wideband) and a narrowband blocking requirement.

### 7.4.1 General blocking minimum requirement

For the general blocking requirement, the interfering signal shall be a UTRA FDD signal as specified in Annex A.

The requirement is always applicable outside the edges of the RF bandwidth. The interfering signal offset is defined relative to the RF bandwidth edges.

For BS operating in non-contiguous spectrum, the requirement applies in addition inside any sub-block gap, in case the sub-block gap size is at least 15 MHz. The interfering signal offset is defined relative to the sub-block edges inside the sub-block gap.

For BS capable of multi-band operation, the requirement applies in addition inside any inter RF bandwidth gap, in case the gap size is at least 15 MHz. The interfering signal offset is defined relative to the RF bandwidth edges inside the inter RF bandwidth gap.

For the wanted and interfering signal coupled to the base station antenna input, using the parameters in Table 7.4.1-1 and 7.4.1-2, the following requirements shall be met:

- For any E-UTRA carrier, the throughput shall be  $\geq 95\%$  of the maximum throughput of the reference measurement channel defined in TS 36.104 [4], subclause 7.2.
- For any UTRA FDD carrier, the BER shall not exceed 0.001 for the reference measurement channel defined in TS 25.104 [2], subclause 7.2.
- For any UTRA TDD carrier, the BER shall not exceed 0.001 for the reference measurement channel defined in TS 25.105 [3], subclause 7.2.
- For any GSM/EDGE carrier, the conditions are specified in TS 45.005 [5], Annex P.2.1.

For BS capable of multi-band operation, the requirement applies according to Table 7.4.1-1 for the in-band blocking frequency ranges of each supported operating band.

**Table 7.4.1-1: General blocking requirement**

Base Station Type	Mean power of interfering signal [dBm]	Wanted Signal mean power [dBm] (Note 1)	Centre Frequency of Interfering Signal	Interfering signal centre frequency minimum frequency offset from the RF bandwidth edge or edge of sub-block inside a gap [MHz]
Wide Area BS	-40	$P_{\text{REFSENS}} + x$ dB (Note 2)	See Table 7.4.1-2	$\pm 7.5$
Medium Range BS	-35	$P_{\text{REFSENS}} + x$ dB (Note 3)		
Local Area BS	-30	$P_{\text{REFSENS}} + x$ dB (Note 4)		
NOTE 1: $P_{\text{REFSENS}}$ depends on the RAT, the BS class and on the channel bandwidth, see subclause 7.2. NOTE 2: For WABS, "x" is equal to 6 in case of E-UTRA or UTRA wanted signals and equal to 3 in case of GSM/EDGE wanted signal. NOTE 3: For MR BS, "x" is equal to 6 in case of UTRA wanted signals, 9 in case of E-UTRA wanted signal and 3 in case of GSM/EDGE wanted signal. NOTE 4: For LABS, "x" is equal to 11 in case of E-UTRA wanted signal, 6 in case of UTRA wanted signal and equal to 3 in case of GSM/EDGE wanted signal. NOTE5: For a BS capable of multi-band operation, "x" in Note 2, 3, 4 apply in case of interfering signals that are in the in-band blocking frequency range of the operating band where the wanted signal is present. For other in-band blocking frequency ranges of the interfering signal for the supported operating bands, "x" is equal to 1.4 dB.				

**Table 7.4.1-2: Interfering signal for the general blocking requirement**

Operating Band Number	Centre Frequency of Interfering Signal [MHz]
1-7, 9-11, 13, 14, 18, 19, 21-23, 24, 27, 33-44	(F <sub>UL_low</sub> -20) to (F <sub>UL_high</sub> +20)
8, 26, 28	(F <sub>UL_low</sub> -20) to (F <sub>UL_high</sub> +10)
12	(F <sub>UL_low</sub> -20) to (F <sub>UL_high</sub> +13)
17	(F <sub>UL_low</sub> -20) to (F <sub>UL_high</sub> +18)
20	(F <sub>UL_low</sub> -11) to (F <sub>UL_high</sub> +20)
25	(F <sub>UL_low</sub> -20) to (F <sub>UL_high</sub> +15)

NOTE: The requirement in Table 7.4.1-1 and 7.4.1-2 assumes that two operating bands, where the downlink operating band (see Table 4.5-1 and Table 4.5-2) of one band would be within the in-band blocking region of the other band, are not deployed in the same geographical area.

## 7.4.2 General narrowband blocking minimum requirement

For the general narrowband blocking requirement, the interfering signal shall be an E-UTRA 1RB signal as specified in Annex A.

The requirement is always applicable outside the edges of the RF bandwidth. The interfering signal offset is defined relative to the RF bandwidth edges.

For BS operating in non-contiguous spectrum, the requirement applies in addition inside any sub-block gap, in case the sub-block gap size is at least 3 MHz. The interfering signal offset is defined relative to the sub-block edges inside the sub-block gap.

For BS capable of multi-band operation, the requirement applies in addition inside any inter RF bandwidth gap in case the gap size is at least 3 MHz. The interfering signal offset is defined relative to the RF bandwidth edges inside the inter RF bandwidth gap.

For the wanted and interfering signal coupled to the base station antenna input, using the parameters in Table 7.4.2-1, the following requirements shall be met:

- For any E-UTRA carrier, the throughput shall be  $\geq 95\%$  of the maximum throughput of the reference measurement channel defined in TS 36.104 [4], subclause 7.2.
- For any UTRA FDD carrier, the BER shall not exceed 0.001 for the reference measurement channel defined in TS 25.104 [2], subclause 7.2.
- For any UTRA TDD carrier, the BER shall not exceed 0.001 for the reference measurement channel defined in TS 25.105 [3], subclause 7.2.
- For any GSM/EDGE carrier, the conditions are specified in TS 45.005 [5], Annex P.2.1.



Table 7.4.2-1: Narrowband blocking requirement

Base Station Type	RAT of the carrier	Wanted signal mean power [dBm] (Note 1)	Interfering signal mean power [dBm]	Interfering RB (Note 3) centre frequency offset from the RF bandwidth edge or edge of sub-block inside a gap [kHz]
Wide Area BS	E-UTRA, UTRA and GSM/EDGE	$P_{\text{REFSENS}} + x$ dB (Note 2)	-49	$\pm(240 + m \cdot 180)$ , $m=0, 1, 2, 3, 4, 9, 14$
Medium Range BS			-44	
Local Area BS			-41	
NOTE 1: $P_{\text{REFSENS}}$ depends on the RAT, the BS class and on the channel bandwidth, see subclause 7.2.				
NOTE 2: "x" is equal to 6 in case of E-UTRA or UTRA wanted signals and equal to 3 in case of GSM/EDGE wanted signal.				
NOTE 3: Interfering signal (E-UTRA 3MHz) consisting of one resource block positioned at the stated offset, the channel bandwidth of the interfering signal is located adjacently to the RF bandwidth edge.				

### 7.4.3 Additional Narrowband blocking minimum requirement for GSM/EDGE

The GSM/EDGE in-band blocking requirement as stated in TS 45.005 [5], applicable parts of subclauses 5.1.3 and 5.1.4, shall apply for any GSM/EDGE carrier.

The conditions specified in TS 45.005 [5], Annex P.2.1 apply for GSM/EDGE in-band narrowband blocking.

### 7.4.4 GSM/EDGE requirements for AM suppression

The GSM/EDGE AM suppression requirement as stated in TS 45.005 [5], applicable parts of subclauses 5.2.2, shall apply for any GSM/EDGE carrier.

The conditions specified in TS 45.005 [5], Annex P.2.3 apply for GSM/EDGE AM suppression.

### 7.4.5 Additional BC3 blocking minimum requirement

The interfering signal is a 1.28 Mcps UTRA TDD modulated signal as specified in Annex A.

The requirement is always applicable outside the edges of the RF bandwidth. The interfering signal offset is defined relative to the RF bandwidth edges.

For BS capable of multi-band operation, the requirement applies in addition inside any inter RF bandwidth gap, in case the gap size is at least 4.8 MHz. The interfering signal offset is defined relative to the RF bandwidth edges inside the inter RF bandwidth gap.

For the wanted and interfering signal coupled to the base station antenna input, using the parameters in Table 7.4.5-1, the following requirements shall be met:

- For any E-UTRA TDD carrier, the throughput shall be  $\geq 95\%$  of the maximum throughput of the reference measurement channel defined in TS 36.104 [4], subclause 7.2.
- For any UTRA TDD carrier, the BER shall not exceed 0.001 for the reference measurement channel defined in TS 25.105 [3], subclause 7.2.

Table 7.4.5-1: Additional blocking requirement for Band Category 3

Operating Band	Centre Frequency of Interfering Signal [MHz]	Interfering Signal mean power [dBm]	Wanted Signal mean power [dBm]	Interfering signal centre frequency minimum frequency offset from the RF bandwidth edge [MHz]
33 - 40	( $F_{UL\_low} - 20$ ) to ( $F_{UL\_high} + 20$ )	-40,	$P_{REFSENS} + 6$ dB*	$\pm 2.4$
NOTE*: $P_{REFSENS}$ depends on the RAT and on the channel bandwidth, see section 7.2.				

## 7.5 Out-of-band blocking

The Out-of-band blocking characteristic is a measure of the receiver ability to receive a wanted signal at its assigned channel in the presence of an unwanted interferer outside the uplink operating band.

### 7.5.1 General minimum requirement

For a wanted and an interfering signal coupled to BS antenna input using the parameters in Table 7.5.1-1, the following requirements shall be met:

- For any E-UTRA carrier, the throughput shall be  $\geq 95\%$  of the maximum throughput of the reference measurement channel defined in TS 36.104 [4], subclause 7.2.
- For any UTRA FDD carrier, the BER shall not exceed 0.001 for the reference measurement channel defined in TS 25.104 [2], subclause 7.2.
- For any UTRA TDD carrier, the BER shall not exceed 0.001 for the reference measurement channel defined in TS 25.105 [3], subclause 7.2.
- For any GSM/EDGE carrier, the conditions are specified in TS 45.005 [5], Annex P.2.1.

For BS capable of multi-band operation, the requirement applies for each supported operating band. The in-band blocking frequency ranges of all supported operating bands according to Table 7.4.1-1 shall be excluded from the requirement.

Table 7.5.1-1: Blocking performance requirement

Operating Band Number	Centre Frequency of Interfering Signal [MHz]	Interfering Signal mean power [dBm]	Wanted Signal mean power [dBm]	Type of Interfering Signal
1-7, 9-11, 13, 14, 18, 19, 21-23, 24, 27, 33-44	1 to ( $F_{UL\_low} - 20$ ) ( $F_{UL\_high} + 20$ ) to 12750	-15	$P_{REFSENS} + x$ dB*	CW carrier
8, 26, 28	1 to ( $F_{UL\_low} - 20$ ) ( $F_{UL\_high} + 10$ ) to 12750	-15	$P_{REFSENS} + x$ dB*	CW carrier
12	1 to ( $F_{UL\_low} - 20$ ) ( $F_{UL\_high} + 13$ ) to 12750	-15	$P_{REFSENS} + x$ dB*	CW carrier
17	1 to ( $F_{UL\_low} - 20$ ) ( $F_{UL\_high} + 18$ ) to 12750	-15	$P_{REFSENS} + x$ dB*	CW carrier
20	1 to ( $F_{UL\_low} - 11$ ) ( $F_{UL\_high} + 20$ ) to 12750	-15	$P_{REFSENS} + x$ dB*	CW carrier
25	1 to ( $F_{UL\_low} - 20$ ) ( $F_{UL\_high} + 15$ ) to 12750	-15	$P_{REFSENS} + x$ dB*	CW carrier
NOTE*: $P_{REFSENS}$ depends on the RAT, the BS class and the channel bandwidth, see subclause 7.2. "x" is equal to 6 in case of E-UTRA or UTRA wanted signals and equal to 3 in case of GSM/EDGE wanted signal.				

## 7.5.2 Co-location minimum requirement

This additional blocking requirement may be applied for the protection of BS receivers when E-UTRA BS, UTRA, CDMA or GSM/EDGE operating in a different frequency band are co-located with a BS.

The requirements in this subclause assume a 30 dB coupling loss between the interfering transmitter and the BS receiver and are based on co-location with base stations of the same class.

For a wanted and an interfering signal coupled to BS antenna input using the parameters in Table 7.5.2-1, the following requirements shall be met:

- For any E-UTRA carrier, the throughput shall be  $\geq 95\%$  of the maximum throughput of the reference measurement channel defined in TS 36.104 [4], subclause 7.2.
- For any UTRA FDD carrier, the BER shall not exceed 0.001 for the reference measurement channel defined in TS 25.104 [2], subclause 7.2.
- For any UTRA TDD carrier, the BER shall not exceed 0.001 for the reference measurement channel defined in TS 25.105 [3], subclause 7.2.
- For any GSM/EDGE carrier, the conditions are specified in TS 45.005 [5], Annex P.2.1.

Table 7.5.2-1: Blocking requirement for co-location with BS in other frequency bands.

Type of co-located BS	Centre Frequency of Interfering Signal (MHz)	Interfering Signal mean power for WA BS (dBm)	Interfering Signal mean power for MR BS (dBm)	Interfering Signal mean power for LA BS (dBm)	Wanted Signal mean power (dBm)	Type of Interfering Signal
GSM850 or CDMA850	869 – 894	+16	+8	-6	$P_{\text{REFSENS}} + x \text{ dB}^*$	CW carrier
GSM900	921 – 960	+16	+8	-6	$P_{\text{REFSENS}} + x \text{ dB}^*$	CW carrier
DCS1800	1805 – 1880 (Note 4)	+16	+8	-6	$P_{\text{REFSENS}} + x \text{ dB}^*$	CW carrier
PCS1900	1930 – 1990	+16	+8	-6	$P_{\text{REFSENS}} + x \text{ dB}^*$	CW carrier
UTRA FDD Band I or E-UTRA Band 1	2110 – 2170	+16	+8	-6	$P_{\text{REFSENS}} + x \text{ dB}^*$	CW carrier
UTRA FDD Band II or E-UTRA Band 2	1930 – 1990	+16	+8	-6	$P_{\text{REFSENS}} + x \text{ dB}^*$	CW carrier
UTRA FDD Band III or E-UTRA Band 3	1805 – 1880 (Note 4)	+16	+8	-6	$P_{\text{REFSENS}} + x \text{ dB}^*$	CW carrier
UTRA FDD Band IV or E-UTRA Band 4	2110 – 2155	+16	+8	-6	$P_{\text{REFSENS}} + x \text{ dB}^*$	CW carrier
UTRA FDD Band V or E-UTRA Band 5	869 – 894	+16	+8	-6	$P_{\text{REFSENS}} + x \text{ dB}^*$	CW carrier
UTRA FDD Band VI or E-UTRA Band 6	875 – 885	+16	+8	-6	$P_{\text{REFSENS}} + x \text{ dB}^*$	CW carrier
UTRA FDD Band VII or E-UTRA Band 7	2620 – 2690	+16	+8	-6	$P_{\text{REFSENS}} + x \text{ dB}^*$	CW carrier
UTRA FDD Band VIII or E-UTRA Band 8	925 – 960	+16	+8	-6	$P_{\text{REFSENS}} + x \text{ dB}^*$	CW carrier
UTRA FDD Band IX or E-UTRA Band 9	1844.9 – 1879.9	+16	+8	-6	$P_{\text{REFSENS}} + x \text{ dB}^*$	CW carrier
UTRA FDD Band X or E-UTRA Band 10	2110 – 2170	+16	+8	-6	$P_{\text{REFSENS}} + x \text{ dB}^*$	CW carrier
UTRA FDD Band XI or E-UTRA Band 11	1475.9 - 1495.9	+16	+8	-6	$P_{\text{REFSENS}} + x \text{ dB}^*$	CW carrier
UTRA FDD Band XII or E-UTRA Band 12	729 - 746	+16	+8	-6	$P_{\text{REFSENS}} + x \text{ dB}^*$	CW carrier
UTRA FDD Band XIII or E-UTRA Band 13	746 - 756	+16	+8	-6	$P_{\text{REFSENS}} + x \text{ dB}^*$	CW carrier
UTRA FDD Band XIV or E-UTRA Band 14	758 - 768	+16	+8	-6	$P_{\text{REFSENS}} + x \text{ dB}^*$	CW carrier
E-UTRA Band 17	734 - 746	+16	+8	-6	$P_{\text{REFSENS}} + x \text{ dB}^*$	CW carrier
E-UTRA Band 18	860 - 875	+16	+8	-6	$P_{\text{REFSENS}} + x \text{ dB}^*$	CW carrier
UTRA FDD Band XIX or E-UTRA Band 19	875 - 890	+16	+8	-6	$P_{\text{REFSENS}} + x \text{ dB}^*$	CW carrier
UTRA FDD Band XX or E-UTRA Band 20	791 - 821	+16	+8	-6	$P_{\text{REFSENS}} + x \text{ dB}^*$	CW carrier
UTRA FDD Band XXI or E-UTRA Band 21	1495.9 – 1510.9	+16	+8	-6	$P_{\text{REFSENS}} + x \text{ dB}^*$	CW carrier
UTRA FDD Band XXII or E-UTRA Band 22	3510 – 3590	+16	+8	-6	$P_{\text{REFSENS}} + x \text{ dB}^*$	CW carrier
E-UTRA Band 23	2180 - 2200	+16	+8	-6	$P_{\text{REFSENS}} + x \text{ dB}^*$	CW carrier
E-UTRA Band 24	1525 – 1559	+16	+8	-6	$P_{\text{REFSENS}} + x \text{ dB}^*$	CW carrier
UTRA FDD Band XXV or E-UTRA Band 25	1930 – 1995	+16	+8	-6	$P_{\text{REFSENS}} + x \text{ dB}^*$	CW carrier
UTRA FDD Band XXVI or E-UTRA Band 26	859 – 894	+16	+8	-6	$P_{\text{REFSENS}} + x \text{ dB}^*$	CW carrier
E-UTRA Band 27	852 - 869	+16	+8	-6	$P_{\text{REFSENS}} + x \text{ dB}^*$	CW carrier
E-UTRA Band 28	758 – 803	+16	+8	-6	$P_{\text{REFSENS}} + x \text{ dB}^*$	CW carrier

E-UTRA Band 29	717 – 728	+16	+8	-6	$P_{\text{REFSENS}} + 6\text{dB}^*$	CW carrier
UTRA TDD Band a) or E-UTRA TDD Band 33	1900-1920	+16	+8	-6	$P_{\text{REFSENS}} + x \text{ dB}^*$	CW carrier
UTRA TDD Band a) or E-UTRA TDD Band 34	2010-2025	+16	+8	-6	$P_{\text{REFSENS}} + x \text{ dB}^*$	CW carrier
UTRA TDD Band b) or E-UTRA TDD Band 35	1850-1910	+16	+8	-6	$P_{\text{REFSENS}} + x \text{ dB}^*$	CW carrier
UTRA TDD Band b) or E-UTRA TDD Band 36	1930-1990	+16	+8	-6	$P_{\text{REFSENS}} + x \text{ dB}^*$	CW carrier
UTRA TDD Band c) or E-UTRA TDD Band 37	1910-1930	+16	+8	-6	$P_{\text{REFSENS}} + x \text{ dB}^*$	CW carrier
UTRA TDD Band d) or E-UTRA Band 38	2570-2620	+16	+8	-6	$P_{\text{REFSENS}} + x \text{ dB}^*$	CW carrier
UTRA TDD Band f) or E-UTRA Band 39	1880-1920	+16	+8	-6	$P_{\text{REFSENS}} + x \text{ dB}^*$	CW carrier
UTRA TDD Band e) or E-UTRA Band 40	2300-2400	+16	+8	-6	$P_{\text{REFSENS}} + x \text{ dB}^*$	CW carrier
E-UTRA Band 41	2496 - 2690	+16	+8	-6	$P_{\text{REFSENS}} + x \text{ dB}^*$	CW carrier
E-UTRA Band 42	3400 – 3600	+16	+8	-6	$P_{\text{REFSENS}} + x \text{ dB}^*$	CW carrier
E-UTRA Band 43	3600 – 3800	+16	+8	-6	$P_{\text{REFSENS}} + x \text{ dB}^*$	CW carrier
E-UTRA Band 44	703 - 803	+16	+8	-6	$P_{\text{REFSENS}} + x \text{ dB}^*$	CW carrier
NOTE 1 (*): $P_{\text{REFSENS}}$ depends on the RAT, the BS class and the channel bandwidth, see subclause 7.2. "x" is equal to 3 in case of GSM/EDGE wanted signal and equal to 6 in case of UTRA or E-UTRA wanted signals.						
NOTE 2: Except for a BS operating in Band 13, these requirements do not apply when the interfering signal falls within any of the supported uplink operating band or in the 10 MHz immediately outside any of the supported uplink operating band. For a BS operating in band 13 the requirements do not apply when the interfering signal falls within the frequency range 768-797 MHz. For BS operating in Band 42 or 43, the requirements do not apply when the interfering signal falls within the Band 42 or 43 uplink operating bands and the Base Stations are synchronized.						
NOTE 3: Some combinations of bands may not be possible to co-site based on the requirements above. The current state-of-the-art technology does not allow a single generic solution for co-location of UTRA TDD or E-UTRA TDD with E-UTRA FDD on adjacent frequencies for 30dB BS-BS minimum coupling loss. However, there are certain site-engineering solutions that can be used. These techniques are addressed in TR 25.942 [7].						
NOTE 4: In China, the blocking requirement for co-location with DCS1800 and Band III BS is only applicable in the frequency range 1805-1850MHz.						

## 7.6 Receiver spurious emissions

The receiver spurious emissions power is the power of emissions generated or amplified in a receiver that appear at the BS receiver antenna connector. The requirements apply to all BS with separate RX and TX antenna ports. In this case for FDD BS the test shall be performed when both TX and RX are on, with the TX port terminated.

For TDD BS with common RX and TX antenna port the requirement applies during the Transmitter OFF period. For FDD BS with common RX and TX antenna port the transmitter spurious emission limits as specified in subclause 6.6.1 are valid.

For BS capable of multi-band operation where multiple bands are mapped on separate antenna connectors, the single-band requirements apply and the excluded frequency range is only applicable for the operating band supported on each antenna connector.

### 7.6.1 General minimum requirement

The power of any spurious emission shall not exceed the levels in Table 7.6.1-1:

**Table 7.6.1-1: General spurious emissions requirement**

Frequency range	Maximum level	Measurement Bandwidth	Note
30MHz - 1 GHz	-57 dBm	100 kHz	
1 GHz – 12.75 GHz	-47 dBm	1 MHz	
12.75 GHz - 5 <sup>th</sup> harmonic of the upper frequency edge of the UL operating band in GHz	-47 dBm	1 MHz	Applies only for Bands 22, 42 and 43.
NOTE: The frequency range from $F_{\text{BWRf,DLlow}} - 10 \text{ MHz}$ to $F_{\text{BWRf,DLhigh}} + 10 \text{ MHz}$ may be excluded from the requirement. For BS capable of multi-band operation, the exclusion applies for all supported operating bands.			

In addition to the requirements in Table 7.6.1-1, the power of any spurious emission shall not exceed the Additional spurious emissions requirements in subclause 6.6.1.3 and in case of FDD BS (for BC1 and BC2) emission shall not exceed the levels specified for Protection of the BS receivers of own or different BS in subclause 6.6.1.2. In addition, the requirements for co-location with other base stations specified in subclause 6.6.1.4 may also be applied.

## 7.6.2 Additional minimum requirement for BC2 (Category B)

For a BS operating in Band Category 2 when GSM/EDGE is configured and where Category B spurious emissions apply, the power of any spurious emissions shall not exceed the limits in Table 7.6.2-1.

For BS capable of multi-band operation, the limits in Table 7.6.2-1 are only applicable when all supported operating bands belong to BC2 and GSM/EDGE is configured in all bands.

**Table 7.6.2-1: Additional BS spurious emissions limits for BC2, Category B**

Frequency range	Frequency offset from downlink operating band edge (Note 1)	Maximum level	Measurement Bandwidth
500 MHz – 1 GHz	10 – 20 MHz	-57 dBm	300 kHz
	20 – 30 MHz	-57 dBm	1 MHz
	$\geq 30 \text{ MHz}$	-57 dBm	3 MHz
1 GHz – 12.75 GHz	$\geq 30 \text{ MHz}$	-47 dBm	3 MHz
NOTE 1: For BS capable of multi-band operation, the frequency offset is relative to the closest supported operating band.			

## 7.7 Receiver intermodulation

Third and higher order mixing of the two interfering RF signals can produce an interfering signal in the band of the desired channel. Intermodulation response rejection is a measure of the capability of the receiver to receive a wanted signal on its assigned channel frequency in the presence of two interfering signals which have a specific frequency relationship to the wanted signal.

### 7.7.1 General intermodulation minimum requirement

Interfering signals shall be a CW signal and an E-UTRA or UTRA signal as specified in Annex A.

The requirement is applicable outside the edges of the RF bandwidth. The interfering signal offset is defined relative to the RF bandwidth edges.

For BS capable of multi-band operation, the requirement applies in addition inside any inter RF bandwidth gap, in case the gap size is at least twice as wide as the UTRA/E-UTRA interfering signal centre frequency offset from the RF bandwidth edge. The interfering signal offset is defined relative to the RF bandwidth edges inside the inter RF bandwidth gap.

For the wanted signal at the assigned channel frequency and two interfering signals coupled to the base station antenna input, using the parameters in Table 7.7.1-1 and 7.7.1-2, the following requirements shall be met:

- For any E-UTRA carrier, the throughput shall be  $\geq 95\%$  of the maximum throughput of the reference measurement channel defined in TS 36.104 [4], subclause 7.2.
- For any UTRA FDD carrier, the BER shall not exceed 0.001 for the reference measurement channel defined in TS 25.104 [2], subclause 7.2.
- For any UTRA TDD carrier, the BER shall not exceed 0.001 for the reference measurement channel defined in TS 25.105 [3], subclause 7.2.
- For any GSM/EDGE carrier, the conditions are specified in TS 45.005 [5], Annex P.2.2.

**Table 7.7.1-1: General intermodulation requirement**

Base Station Type	Mean power of interfering signals [dBm]	Wanted Signal mean power [dBm]	Type of interfering signal
Wide Area BS	-48	$P_{\text{REFSENS}} + x$ dB (Note 2)	See Table 7.7.1-2
Medium Range BS	-44	$P_{\text{REFSENS}} + x$ dB (Note 3)	
Local Area BS	-38	$P_{\text{REFSENS}} + x$ dB (Note 4)	
NOTE 1: $P_{\text{REFSENS}}$ depends on the RAT, the BS class and on the channel bandwidth, see subclause 7.2.			
NOTE 2: For WABS, "x" is equal to 6 in case of E-UTRA or UTRA wanted signals and equal to 3 in case of GSM/EDGE wanted signal.			
NOTE 3: For MR BS, "x" is equal to 6 in case of UTRA wanted signals, 9 in case of E-UTRA wanted signal and equal to 3 in case of GSM/EDGE wanted signal.			
NOTE 4: For LABS, "x" is equal to 12 in case of E-UTRA wanted signals, 6 in case of UTRA wanted signal and equal to 3 in case of GSM/EDGE wanted signal.			

**Table 7.7.1-2: Interfering signals for intermodulation requirement**

RAT of the carrier adjacent to the high (low) edge of the RF bandwidth	Interfering signal centre frequency offset from the RF bandwidth edge [MHz]	Type of interfering signal
E-UTRA 1.4 MHz	$\pm 2.0$ (BC1 and BC3) / $\pm 2.1$ (BC2)	CW
	$\pm 4.9$	1.4MHz E-UTRA signal
E-UTRA 3 MHz	$\pm 4.4$ (BC1 and BC3) / $\pm 4.5$ (BC2)	CW
	$\pm 10.5$	3MHz E-UTRA signal
UTRA FDD and E-UTRA 5 MHz	$\pm 7.5$	CW
	$\pm 17.5$	5MHz E-UTRA signal
E-UTRA 10 MHz	$\pm 7.375$	CW
	$\pm 17.5$	5MHz E-UTRA signal
E-UTRA 15 MHz	$\pm 7.25$	CW
	$\pm 17.5$	5MHz E-UTRA signal
E-UTRA 20 MHz	$\pm 7.125$	CW
	$\pm 17.5$	5MHz E-UTRA signal
GSM/EDGE	$\pm 7.575$	CW
	$\pm 17.5$	5MHz E-UTRA signal
1.28 Mcps UTRA TDD	$\pm 2.3$ (BC3)	CW
	$\pm 5.6$ (BC3)	1.28Mcps UTRA TDD signal

## 7.7.2 General narrowband intermodulation minimum requirement

Interfering signals shall be a CW signal and an E-UTRA 1RB signal as specified in Annex A.

The requirement is always applicable outside the edges of the RF bandwidth. The interfering signal offset is defined relative to the RF bandwidth edges.

For BS operating in non-contiguous spectrum within each supported operating band, the requirement applies in addition inside any sub-block gap in case the sub-block gap is at least as wide as the channel bandwidth of the E-UTRA interfering signal in Table 7.7.2-2. The interfering signal offset is defined relative to the sub-block edges inside the gap.

For BS capable of multi-band operation, the requirement applies in addition inside any inter RF bandwidth gap in case the gap size is at least as wide as the E-UTRA interfering signal in Table 7.7.2-2. The interfering signal offset is defined relative to the RF bandwidth edges inside the inter RF bandwidth gap.

For the wanted signal at the assigned channel frequency and two interfering signals coupled to the base station antenna input, using the parameters in Table 7.7.2-1 and 7.7.2-2, the following requirements shall be met:

- For any E-UTRA carrier, the throughput shall be  $\geq 95\%$  of the maximum throughput of the reference measurement channel defined in TS 36.104 [4], subclause 7.2.
- For any UTRA FDD carrier, the BER shall not exceed 0.001 for the reference measurement channel defined in TS 25.104 [2], subclause 7.2.
- For any UTRA TDD carrier, the BER shall not exceed 0.001 for the reference measurement channel defined in TS 25.105 [3], subclause 7.2.
- For any GSM/EDGE carrier, the conditions are specified in TS 45.005 [5], Annex P.2.2.

**Table 7.7.2-1: General narrowband intermodulation requirement**

Base Station Type	Mean power of interfering signals [dBm]	Wanted Signal mean power [dBm]	Type of interfering signal
Wide Area BS	-52	$P_{\text{REFSENS}} + x \text{ dB}^*$	See Table 7.7.2-2
Medium Range BS	-47		
Local Area BS	-44		
NOTE*: $P_{\text{REFSENS}}$ depends on the RAT, the BS class and on the channel bandwidth, see subclause 7.2. "x" is equal to 6 in case of E-UTRA or UTRA wanted signals and equal to 3 in case of GSM/EDGE wanted signal.			



Table 7.7.2-2: Interfering signals for narrowband intermodulation requirement

RAT of the carrier adjacent to the high (low) edge of the RF bandwidth or the sub-block	CW or 1RB interfering signal centre frequency offset from the RF bandwidth edge or edge of sub-block inside a gap [kHz]	Type of interfering signal
E-UTRA 1.4 MHz	$\pm 260$ (BC1 and BC3) / $\pm 270$ (BC2)	CW
	$\pm 970$ (BC1 and BC3) / $\pm 790$ (BC2)	1.4 MHz E-UTRA signal, 1 RB*
E-UTRA 3 MHz	$\pm 260$ (BC1 and BC3) / $\pm 270$ (BC2)	CW
	$\pm 960$ (BC1 and BC3) / $\pm 780$ (BC2)	3.0 MHz E-UTRA signal, 1 RB*
E-UTRA 5 MHz	$\pm 360$	CW
	$\pm 1060$	5 MHz E-UTRA signal, 1 RB*
E-UTRA 10 MHz (**)	$\pm 325$	CW
	$\pm 1240$	5 MHz E-UTRA signal, 1 RB*
E-UTRA 15 MHz (**)	$\pm 380$	CW
	$\pm 1600$	5MHz E-UTRA signal, 1 RB*
E-UTRA 20 MHz (**)	$\pm 345$	CW
	$\pm 1780$	5MHz E-UTRA signal, 1 RB*
UTRA FDD	$\pm 345$ (BC1 and BC2)	CW
	$\pm 1780$ (BC1 and BC2)	5MHz E-UTRA signal, 1 RB*
GSM/EDGE	$\pm 340$	CW
	$\pm 880$	5MHz E-UTRA signal, 1 RB*
1.28Mcps UTRA TDD	$\pm 190$ (BC3)	CW
	$\pm 970$ (BC3)	1.4 MHz E-UTRA signal, 1 RB*
NOTE*: Interfering signal consisting of one resource block positioned at the stated offset, the channel bandwidth of the interfering signal is located adjacently to the RF bandwidth edge.		
NOTE**: This requirement shall apply only for an E-UTRA FRC A1-3 mapped to the frequency range at the channel edge adjacent to the interfering signals.		

### 7.7.3 Additional narrowband intermodulation minimum requirement for GSM/EDGE

The GSM/EDGE MC-BTS receiver intermodulation requirement as stated in TS 45.005 [5], applicable parts of subclause 5.3.2 shall apply for any GSM/EDGE carrier.

The conditions specified in TS 45.005 [5], Annex P.2.2 apply for the GSM/EDGE intermodulation requirement.

## 7.8 In-channel selectivity

In-channel selectivity (ICS) is a measure of the receiver ability to receive a wanted signal at its assigned resource block locations in the presence of an interfering signal received at a larger power spectral density. In this condition a throughput requirement shall be met for a specified reference measurement channel.

### 7.8.1 E-UTRA minimum requirement

For E-UTRA, the minimum requirement for in-channel selectivity is specified in TS 36.104 [4], subclause 7.4.

---

## 8 Performance requirements

Performance requirements specify the ability of the BS to correctly demodulate signals in various conditions and configurations. For UTRA and E-UTRA the requirements specify a minimum throughput or maximum BLER or BER that shall be achieved at a specific SNR. For GSM/EDGE the requirements specify a maximum FER, BLER or BER that shall be achieved at specific sensitivity levels (C) and specific carrier-to-interference ratios (C/I).

## 8.1 E-UTRA minimum requirement

For E-UTRA, the minimum requirements for performance are specified in TS 36.104 [4], clause 8.

## 8.2 UTRA FDD minimum requirement

For UTRA FDD, the minimum requirements for performance are specified in TS 25.104 [2], clause 8.

## 8.3 UTRA TDD minimum requirement

For UTRA TDD, the minimum requirements for performance are specified in TS 25.105 [3], clause 8.

## 8.4 GSM/EDGE minimum requirement

For GSM/EDGE, the minimum requirements for reference sensitivity level and reference interference level are specified in TS 45.005 [5], applicable parts of clauses 6.2, 6.3, 6.4, 6.5 and 6.6. The conditions specified in TS 45.005 [5], Annex P.1 are valid for GSM sensitivity and interference performance.

---

## Annex A (normative): Characteristics of interfering signals

### A.1 UTRA FDD interfering signal

The UTRA FDD interfering signal shall be a DPCH containing the DPCCH and one DPDCH. The data content for each channelization code shall be uncorrelated with each other and to the wanted signal and spread and modulated according to clause 4 of TS 25.213. Further characteristics of DPDCH and DPCCH are specified in Table A.1-1.

**Table A.1-1: Characteristics of UTRA FDD interfering signal**

Channel	Bit Rate	Spreading Factor	Channelization Code	Relative Power
DPDCH	240 kbps	16	4	0 dB
DPCCH	15 kbps	256	0	-5.46 dB
NOTE: The DPDCH and DPCCH settings are chosen to simulate a signal with realistic Peak to Average Ratio.				

---

### A.2 UTRA TDD interfering signal

The UTRA TDD interfering signal shall be 1.28 Mcps UTRA TDD signal with one code. The data content shall be uncorrelated to the wanted signal. They are specified in Table A.2-1.

**Table A.2-1: Characteristics of UTRA TDD interfering signal**

UTRA TDD option	Type of Interfering Signal
1.28 Mcps UTRA TDD	1,28 Mcps UTRA TDD signal with one code*
* NOTE: The channelisation code ID and Midamble shift shall be different with the wanted signal's.	

---

### A.3 E-UTRA interfering signal

The E-UTRA interfering signal shall be a PUSCH containing data and reference symbols. Normal CP is used. The data content shall be uncorrelated to the wanted signal and modulated according to clause 5 of TS 36.211. Mapping of PUSCH modulation to receiver requirement are specified in Table A.3-1.

**Table A.3-1: Modulation of the E-UTRA interfering signal**

Receiver requirement	Modulation
Narrowband blocking	QPSK
Receiver intermodulation	QPSK

---

## Annex B (normative): Environmental requirements for the BS equipment

The BS equipment shall fulfil all the requirements in the full range of environmental conditions for the relevant environmental class. The environmental conditions and class shall be from the relevant IEC specifications or the corresponding ETSI specifications listed below.

IEC specifications for environmental requirements:

IEC 60 721-3-3 "Stationary use at weather protected locations" [11]

IEC 60 721-3-4 "Stationary use at non weather protected locations" [12]

ETSI specifications for environmental requirements:

ETSI EN 300 019-1-3 "Stationary use at weather protected locations" [13]

ETSI EN 300 019-1-4 "Stationary use at non weather protected locations" [14]

Normally it should be sufficient for all tests to be conducted using normal test conditions except where otherwise stated. For guidance on the use of test conditions to be used in order to show compliance refer to TS 37.141 [10].

## Annex C (informative): Change history

Change history							
Date	TSG #	TSG Doc.	CR	Rev	Subject/Comment	Old	New
2009-07	R4#51bis	R4-092358			Specification skeleton		0.0.1
2009-08	R4#52	R4-093257			<p>Agreed Text Proposals in RAN4#52:</p> <p><b>R4-093005</b>, "TS 37.104: TP on Relationship between minimum requirements and test requirements (TS ch 4.2)"</p> <p><b>R4-093006</b>, "TS 37.104: TP on Base station classes (TS ch 4.3)"</p> <p><b>R4-093008</b>, "TS 37.104: TP on Operating bands and Band Categories (TS ch 4.5)"</p> <p><b>R4-093009</b>, "TS 37.104: TP on Channel arrangement (TS ch 4.6)"</p> <p><b>R4-093011</b>, "TS 37.104: TP on Transmitter characteristics - General (TS ch 6.1)"</p> <p><b>R4-093012</b>, "TS 37.104: TP on Output power dynamics (TS ch 6.3)"</p> <p><b>R4-093016</b>, "TS 37.104: TP on Transmitter Intermodulation (TS ch 6.7)"</p> <p><b>R4-093017</b>, "TS 37.104: TP on Receiver characteristics General (TS ch 7.1)"</p> <p><b>R4-093018</b>, "TS 37.104: TP on Reference sensitivity level (TS ch 7.2)"</p> <p><b>R4-093019</b>, "TS 37.104: TP on Dynamic range (TS ch 7.3)"</p> <p><b>R4-093022</b>, "TS 37.104: TP on Receiver spurious emissions (TS ch 7.6)"</p> <p><b>R4-093024</b>, "TS 37.104: TP on In-channel selectivity (TS ch 7.8)"</p> <p><b>R4-093375</b>, "TS 37.104: TP on MSR References and definitions (TS ch 2 and 3)"</p> <p><b>R4-093376</b>, "TS 37.104: TP on Regional requirements (TS ch 4.4)"</p> <p><b>R4-093378</b>, "TS 37.104: TP on Transmitted signal quality (TS ch 6.5)"</p> <p><b>R4-093379</b>, "TS 37.104: TP on Transmitter spurious emissions (TS ch 6.6 and 6.6.1)"</p> <p><b>R4-093380</b>, "TS 37.104: TP on Operating band unwanted emissions (TS ch 6.6.2)"</p> <p><b>R4-093381</b>, "TS 37.104: TP on In-band selectivity and blocking (TS ch 7.4)"</p> <p><b>R4-093382</b>, "TS 37.104: TP on Out-of-band blocking (TS ch 7.5)"</p> <p><b>R4-093383</b>, "TS 37.104: TP on Receiver intermodulation (TS ch 7.7)"</p>	0.0.1	0.1.0
2009-09	RAN #45	RP-090764			Presentation to TSG RAN for information	0.1.0	1.0.0
2009-10	R4#52bis	R4-093979			<p>Agreed Text Proposals in RAN4#52bis:</p> <p><b>R4-093788</b>, "TS 37.104: TP on Relation to other RAN and GERAN specifications (TS ch 4.2)"</p> <p><b>R4-093792</b>, "TS 37.104: TP on Spurious emissions requirements in BC2 (TS ch 6.6.2 and 7.6)"</p> <p><b>R4-093796</b>, "TS 37.104: TP on Characteristics of interfering signals"</p> <p><b>R4-094013</b>, "Clarification on Spurious emissions limits for BS co-existed with another BS (37.104)"</p> <p><b>R4-094050</b>, "TS 37.104: TP on Additional spurious emissions requirement (TS ch 6.6.1.3)"</p> <p><b>R4-094051</b>, "TS 37.104: TP on Introduction of BC2 transmitter requirements (TS ch 6)"</p> <p><b>R4-094052</b>, "TS 37.104: TP on Introduction of BC2 receiver requirements (TS ch 7)"</p> <p><b>R4-094053</b>, "TS 37.104: TP on Applicability of requirements (TS ch 5)"</p> <p><b>R4-094054</b>, "TS 37.104: TP on Performance requirements"</p>	1.0.0	1.1.0

					(TS ch 8)" <b>R4-094058</b> , "TP for 37.104 Maximum power requirements"		
2009-11	R4#53	R4-094476			Agreed Text Proposals in RAN4#52bis: <b>R4-094061</b> , "A Note of 37.104 MSR category 3 on additional spurious emission requirement when BC3 is deployed in the same geographical area as the PHS" <b>R4-094062</b> , "TP of 37.104 on Transmitter intermodulation requirement of MSR category 3" <b>R4-094063</b> , "TP of 37.104 on Out-of-band blocking requirement of MSR category 3" <b>R4-094075</b> , "Text proposal of transmitter off power for TS37.104" <b>R4-094076</b> , "Text proposal of receiver intermodulation of BC3 for TS37.104"	1.1.0	1.2.0
2009-11	R4#53	R4-094777			Agreed Text Proposals in RAN4#53: <b>R4-094403</b> , "Corrections on frequency range of unwanted emissions requirements (37.104)" <b>R4-094479</b> , "TS 37.104: TP on Occupied bandwidth (TS ch 6.6.3)" <b>R4-094480</b> , "TS 37.104: TP on remaining BC3 transmitter requirements (TR ch 6)" <b>R4-094484</b> , "TS 37.104: TP on Inclusion of requirements by reference (TS ch 5.4)" <b>R4-094485</b> , "TS 37.104: TP on additional emission requirements for GSM (TS ch 6.6.2.3)" <b>R4-094486</b> , "TS 37.104: TP on General updates" <b>R4-094540</b> , "Output Power clarification" <b>R4-094662</b> , "TS 37.104: TP for scope update (TS ch 1)" <b>R4-094663</b> , "TS 37.104: TP on Environmental requirements for the BS equipment (TS Annex B)" <b>R4-094862</b> , "TS 37.104: TP for ACLR requirement (TS ch 6.6.4)" <b>R4-094863</b> , "TS 37.104: TP on Applicability of requirements for BC3" <b>R4-094881</b> , "Proposed updates of references to TS 45.005 in MSR specification TR 37.104 (GERAN1 AHG1-090157)" <b>R4-094882</b> , "TS 37.104: TP on Declared output power parameters" <b>R4-094883</b> , "TS 37.104: TP on remaining BC3 receiver requirements (TS ch 7)"	1.2.0	1.3.0
2009-12	RAN #46	RP-091107			Presentation to TSG RAN for approval.	1.3.0	2.0.0
2009-12	RAN #46	RP-091107			Approved in TSG RAN#46	2.0.0	9.0.0
2010-03	RAN #47	RP-100265	1		Correction of additional spurious emission requirement for BC2	9.0.0	9.1.0
2010-03	RAN #47	RP-100265	7		ACLR requirement E-UTRA channel BW <5 MHz	9.0.0	9.1.0
2010-03	RAN #47	RP-100265	3		MSR corrections in TS 37.104	9.0.0	9.1.0
2010-03	RAN #47	RP-100265	5	1	Alignment of MSR specification with new items in single-RAT specifications	9.0.0	9.1.0
2010-03	RAN #47	RP-100265	6		Correction of scope	9.0.0	9.1.0
2010-06	RP-48	RP-100625	014		Corrections to clause 7.1	9.1.0	9.2.0
2010-06	RP-48	RP-100625	013	1	Corrections to MSR core requirements	9.1.0	9.2.0
2010-06	RP-48	RP-100625	012		Correction to Clause 6.1	9.1.0	9.2.0
2010-06	RP-48	RP-100625	010	1	Clarification to the receiver narrowband blocking requirement	9.1.0	9.2.0
2010-06	RP-48	RP-100625	009	1	Clarification to the receiver narrowband intermodulation requirement	9.1.0	9.2.0
2010-06	RP-48	RP-100625	008	2	Co-existence with services in adjacent frequency bands	9.1.0	9.2.0
2010-06	RP-48	RP-100625	015		Spurious emissions limits and blocking requirements for coexistence with CDMA850	9.1.0	9.2.0
2010-09	RP-49	RP-100922	018	1	TS 37.104 Subclause 7.7; Receiver intermodulation	9.2.0	9.3.0
2010-09	RP-49	RP-100927	016		CR LTE_TDD_2600_US spectrum band definition additions to TS 37.104	9.3.0	10.0.0
2010-12	RP-50	RP-101345	023		Band XIV/12 frequency range	10.0.0	10.1.0
2010-12	RP-50	RP-101356	019	4	Band 42 and 43 parameters for UMTS/LTE 3500 (TDD) for TS 37.104	10.0.0	10.1.0
2010-12	RP-50	RP-101359	024		Introduction of Carrier Aggregation for LTE in TS 37.104	10.0.0	10.1.0
2010-12	RP-50	RP-101361	020		Protection of E-UTRA Band 24	10.0.0	10.1.0
2011-04	RP-51	RP-110357	002 9	-	Band 42 and 43 co-existence for UMTS/LTE 3500 (TDD) for TS 37.104	10.1.0	10.2.0
2011-06	RP-52	RP-110794	033		Modifications to Band 3 to allow LTE Band 3 operation in Japan (Rel-10 TS37.104 CR)	10.2.0	10.3.0

2011-06	RP-52	RP-110812	034		Add 2GHz S-Band (Band 23) in 37.104	10.2.0	10.3.0
2011-06	RP-52	RP-110804	035		Add Expanded 1900MHz band in 37.104	10.2.0	10.3.0
2011-06	RP-52	RP-110794	041		Correction of RX spurious emissions for non-GSM/EDGE configurations	10.2.0	10.3.0
2011-06	RP-52	RP-110802	044		Co-existence/co-location between Band 42 and 43 in TS 37.104	10.2.0	10.3.0
2011-06	RP-52	RP-110807	043	1	LTE CA alignment of definitions in TS 37.104	10.2.0	10.3.0
2011-06	RP-52	RP-110794	039	1	General corrections for TS 37.104	10.2.0	10.3.0
2011-06	RP-52	RP-110795	037	3	Fixing Band 24 inclusion in TS 37.104	10.2.0	10.3.0
2011-06	RP-52	RP-110805	042	1	MSR-NC Core requirements	10.2.0	10.3.0
2011-06	RP-52	RP-110794	046	2	Revision of Time Alignment Error definition	10.2.0	10.3.0
2011-09	RP-53	RP-111252	051		Correcting the time alignment text in the applicability tables	10.3.0	10.4.0
2011-09	RP-53	RP-111255	052	1	Add Band 22/XXII for LTE/UMTS 3500 (FDD) to TS 37.104	10.3.0	10.4.0
2011-09	RP-53	RP-111262	049		Co-existence and co-location corrections in 37.104	10.3.0	10.4.0
2011-12	RP-54	RP-111735	053		Definition of multi-carrier configuration	10.4.0	10.5.0
2011-12	RP-54	RP-111734	054		Clarification of general blocking requirements for co-existence in TS 37.104	10.4.0	10.5.0
2011-12	RP-54	RP-111735	055		CR to TS37.104 Adding the OBW requirements for carrier aggregation	10.4.0	10.5.0
2011-12	RP-54	RP-111735	056		Correction of MSR NC requirements	10.4.0	10.5.0
2011-12	RP-54	RP-111687	058	2	TX ON or OFF CR 37.104	10.4.0	10.5.0
2011-12	RP-54	RP-111733	059		Correction of frequency range for spurious emission requirements	10.4.0	10.5.0
2012-03	RP-55	RP-120303	062		Update to improve readability of tables in section 4.5 of 37.104	10.5.0	10.6.0
2012-03	RP-55	RP-120303	063		Absolute limit for CACLR: Removal of brackets	10.5.0	10.6.0
2012-03	RP-55	RP-120304	065	1	Definition of synchronized operation	10.5.0	10.6.0
2012-03	RP-55	RP-120303	066	1	Introduction of NC operation for TDD in 37.104	10.5.0	10.6.0
2012-03	RP-55	RP-120305	061		Add Extending 850 MHz Upper Band (814 - 849 MHz) to TS37.104	10.6.0	11.0.0
2012-06	RP-56	RP-120793	069	-	Introduction of APAC700(FDD) into TS 37.104	11.0.0	11.1.0
2012-06	RP-56	RP-120771	072	-	Introduction of Japanese Regulatory Requirements to W-CDMA Band VIII (R11)	11.0.0	11.1.0
2012-06	RP-56	RP-120777	074	-	Additional BC3 blocking	11.0.0	11.1.0
2012-06	RP-56	RP-120793	075	1	Introduction of Band 44	11.0.0	11.1.0
2012-06	RP-56	RP-120791	076	2	Introduction of E850_LB (Band 27) to MSR TS 37.104	11.0.0	11.1.0
2012-09	RP-57	RP-121310	078	-	Applicability of Cumulative ACLR	11.1.0	11.2.0
2012-09	RP-57	RP-121310	080	-	Correct the f_offsetmax definition for TS 37.104	11.1.0	11.2.0
2012-09	RP-57	RP-121308	081	2	Reusing band 41 requirements for the Japan 2.5G TDD band	11.1.0	11.2.0
2012-09	RP-57	RP-121310	083	1	Intra-band non-contiguous receiver requirements	11.1.0	11.2.0
2012-09	RP-57	RP-121310	085	-	Deleting additional BC3 transmitter intermodulation requirement for NC MSR	11.1.0	11.2.0
2012-09	RP-57	RP-121300	088	-	Modifications of frequency ranges on spurious emission requirements for Band 6, 18, 19	11.1.0	11.2.0

2012-09	RP-57	RP-121310	090	1	Clean-up of ACLR wording for MSR-NC	11.1.0	11.2.0
2012-09	RP-57	RP-121340	091	1	Modification to increase GSM Carrier Power in MSR BS for Band Category 2	11.1.0	11.2.0
2012-09	RP-57				Editorial correction in Table 6.6.2.2-2	11.2.0	11.2.1
2012-12	RP-58	RP-121906	094		Introduction of new BS classes to MSR specification (general parts)	11.2.1	11.3.0
2012-12	RP-58	RP-121857	095		Correction to additional BS spurious emissions limits for BC2	11.2.1	11.3.0
2012-12	RP-58	RP-121859	098		Correction of PHS protection requirement	11.2.1	11.3.0
2012-12	RP-58	RP-121906	101	2	Introduction of new BS classes to MSR specification (Clause 6)	11.2.1	11.3.0
2012-12	RP-58	RP-121906	102		Introduction of new BS classes to MSR specification (receiver part)	11.2.1	11.3.0
2012-12	RP-58	RP-121867	104	1	Modification on ACLR requirement	11.2.1	11.3.0
2012-12	RP-58	RP-121867	107		Clean up of specification R11	11.2.1	11.3.0
2012-12	RP-58	RP-121905	108	1	Introduction of multi-band operation to MSR specification (section 4)	11.2.1	11.3.0
2012-12	RP-58	RP-121905	109	1	CR for TS37.104(Clause 1-3) due to introduction of multi-band MSR operation	11.2.1	11.3.0
2012-12	RP-58	RP-121905	110	1	Introduction of MB-MSR to MSR specification (Clause 6)	11.2.1	11.3.0
2012-12	RP-58	RP-121864	112		Transmitter IM correction for MSR-NC	11.2.1	11.3.0
2012-12	RP-58	RP-121905	113		Applicability of requirements for MB-MSR	11.2.1	11.3.0
2012-12	RP-58	RP-121899	115		Update CA reference to include Non Contiguous CA band combinations	11.2.1	11.3.0
2012-12	RP-58	RP-121901	116		Introduction of Band 29	11.2.1	11.3.0
2012-12	RP-58	RP-121905	117	1	Introduction of MB-MSR to MSR core specification (Clause 7)	11.2.1	11.3.0
2012-12	RP-58	RP-121857	118		Modification to increase GSM Carrier Power in MSR BS for Band Category 2	11.2.1	11.3.0
2012-12					Editorial Correction	11.3.0	11.3.0
2013-03	RP-59	RP-130282	121		Clarify unclear description in UEM requirement for MB-MSR in TS 37.104	11.3.1	11.4.0
2013-03	RP-59	RP-130282	125		Some clarifications on MB-MSR requirement in TS 37.104	11.3.1	11.4.0
2013-03	RP-59	RP-130282	126	1	Introduction of MB-MSR to MR/LA BS in TS 37.104	11.3.1	11.4.0
2013-03	RP-59	RP-130287	129		Correction of co-existence spurious emission requirement with Band 23 for TS 37.104 (R11)	11.3.1	11.4.0
2013-03	RP-59	RP-130287	130		Band 41 requirements for operation in Japan	11.3.1	11.4.0
2013-06	RP-60	RP-130769	135		Definition of Inter RF bandwidth gap	11.4.0	11.5.0
2013-06	RP-60	RP-130764	138		Corrections to transmitter intermodulation test requirement	11.4.0	11.5.0
2013-06	RP-60	RP-130763	142		channel raster	11.4.0	11.5.0
2013-06	RP-60	RP-130769	144	2	Mapping of requirements on antenna ports	11.4.0	11.5.0
2013-09	RP-61	RP-131280	152		UEM requirement in BC2 for lower BS output power	11.5.0	11.6.0
2013-09	RP-61	RP-131289	153	1	Single-RAT operation for MB-MSR	11.5.0	11.6.0
2013-09	RP-61	RP-131289	156		Clarification on single-band operation for MB-MSR	11.5.0	11.6.0