

3GPP TR 36.912 V11.0.0 (2012-09)

Technical Report

3rd Generation Partnership Project; Technical Specification Group Radio Access Network; Feasibility study for Further Advancements for E-UTRA (LTE-Advanced) (Release 11)



The present document has been developed within the 3rd Generation Partnership Project (3GPPTM) and may be further elaborated for the purposes of 3GPP.

The present document has not been subject to any approval process by the 3GPP Organizational Partners and shall not be implemented. This Specification is provided for future development work within 3GPP only. The Organizational Partners accept no liability for any use of this Specification. Specifications and reports for implementation of the 3GPPTM system should be obtained via the 3GPP Organizational Partners' Publications Offices.

Keywords

LTE, Radio

3GPP

Postal address

3GPP support office address

650 Route des Lucioles - Sophia Antipolis
Valbonne - FRANCE
Tel.: +33 4 92 94 42 00 Fax: +33 4 93 65 47 16

Internet

<http://www.3gpp.org>

Copyright Notification

No part may be reproduced except as authorized by written permission.
The copyright and the foregoing restriction extend to reproduction in all media.

© 2012, 3GPP Organizational Partners (ARIB, ATIS, CCSA, ETSI, TTA, TTC).
All rights reserved.

UMTS™ is a Trade Mark of ETSI registered for the benefit of its members
3GPP™ is a Trade Mark of ETSI registered for the benefit of its Members and of the 3GPP Organizational Partners
LTE™ is a Trade Mark of ETSI currently being registered for the benefit of its Members and of the 3GPP Organizational Partners
GSM® and the GSM logo are registered and owned by the GSM Association

Contents

Foreword	6
1 Scope	7
2 References	7
3 Definitions, symbols and abbreviations	8
3.1 Definitions	8
3.2 Symbols	8
3.3 Abbreviations	8
4 Introduction	8
5 Support of wider bandwidth	8
5.1 General	8
5.1A Physical layer	9
5.1A.1 DL control signalling	9
5.1A.2 UL control signalling	9
5.2 User Plane	10
5.2.1 Structure	10
5.2.2 MAC	11
5.2.3 RLC	11
5.2.4 PDCP	11
5.3 Control plane	11
5.3.1 Structure	11
5.3.2 RRC procedures	12
5.3.2.1 System Information	12
5.3.2.2 Connection Control	12
5.3.2.3 Measurements	12
5.3.3 Idle mode procedures	12
6 Uplink transmission scheme	12
6.1 Uplink spatial multiplexing	12
6.1A Uplink transmit diversity	14
6.1A.1 Transmit Diversity for Uplink Control Channel	14
6.2 Uplink multiple access	14
6.3 Uplink reference signals	15
6.4 Uplink power control	15
7 Downlink transmission scheme	15
7.0 Physical channel mapping	15
7.1 Downlink spatial multiplexing	15
7.1.1 Feedback in support of downlink spatial multiplexing	16
7.2 Downlink reference signals	16
7.3 Downlink transmit diversity	17
8 Coordinated multiple point transmission and reception	17
8.1 Downlink coordinated multi-point transmission	17
8.2 Uplink coordinated multi-point reception	17
9 Relaying	17
9.1 General	17
9.2 Architecture	18
9.3 Relay-eNodeB link for inband relay	18
9.3.1 Resource partitioning for relay-eNodeB link	18
9.3.2 Backward compatible backhaul partitioning	19
9.3.3 Backhaul resource assignment	19
9.4 Relay-eNodeB link for outband relay	20
10 Improvement for latency	20
10.1 Improvement for C-Plane latency	20

10.2	Improvement for U-Plane latency	21
11	Radio transmission and reception	21
11.1	RF scenarios	21
11.1.1	Deployment scenarios	21
11.2	Common requirements for UE and BS	21
11.2.1	Carrier Aggregation	21
11.2.1.1	Bandwidth configuration of component carriers	21
11.2.1.2	Carrier spacing between component carriers	21
11.2.2	Operating bands.....	22
11.3	UE RF requirements.....	23
11.3.1	General.....	23
11.3.2	Transmitter characteristics.....	23
11.3.2.1	Transmitter architecture.....	23
11.3.2.2	Transmit power	24
11.3.2.3	Output power dynamics	24
11.3.2.4	Transmit signal quality	25
11.3.2.5	Output RF spectrum emissions.....	25
11.3.2.5.1	Adjacent Channel Leakage ratio	25
11.3.2.5.2	Spurious emission (UE to UE co-existence).....	25
11.3.2.6	Transmit intermodulation	25
11.3.3	Receiver characteristics	25
11.3.3.1	Receiver architecture	26
11.3.3.2	Receiver Sensitivity	26
11.3.3.3	Selectivity.....	26
11.3.3.4	Blocking performance.....	27
11.3.3.5	Spurious response	27
11.3.3.6	Intermodulation performance	27
11.3.3.7	Spurious emission	27
11.4	BS RF requirements	27
11.4.1	General.....	27
11.4.2	Transmitter characteristics.....	28
11.4.2.1	Base Station output power.....	28
11.4.2.2	Transmitted signal quality	28
11.4.2.3	Unwanted emissions.....	28
11.4.2.4	Transmitter spurious emissions.....	28
11.4.3	Receiver characteristics	29
11.4.3.1	Reference sensitivity level.....	29
11.4.3.2	Adjacent Channel Selectivity (ACS), narrow-band blocking, Blocking, Receiver intermodulation	29
11.4.3.3	Performance requirements.....	29
12	Mobility enhancements.....	29
13	TS 36.133 [17] requirements enhancements	30
14	MBMS Enhancements.....	30
15	SON Enhancements	30
16	Self-Evaluation Report on "LTE Release 10 and beyond (LTE-Advanced)"	30
16.1	Peak spectral efficiency	31
16.2	C-plane latency	32
16.2.1	Idle to Connected	32
16.2.2	Dormant to Active.....	33
16.3	U-Plane latency.....	34
16.4	Spectral efficiency and user throughput	34
16.4.1	Cell spectral efficiency and cell-edge spectral efficiency	34
16.4.1.1	Indoor.....	34
16.4.1.2	Microcellular	35
16.4.1.3	Base coverage urban.....	36
16.4.1.4	High speed.....	37
16.4.2	Number of supported VoIP users	39
16.4.3	Mobility traffic channel link data rates	39
16.5	Handover Performance	40

16.5.1	Intra-frequency handover interruption time	42
16.5.2	Inter-frequency handover interruption time within a spectrum band	42
16.5.3	Inter-frequency handover interruption time between spectrum bands	42
16.6	Spectrum and bandwidth	42
16.6.1	Deployment in IMT bands	42
16.6.2	Bandwidth and channel bandwidth scalability	43
16.7	Services	43
16.8	Conclusions of the Self-Evaluation	43
16A	Performance Evaluation of LTE-Advanced for 3GPP target fulfillment	44
17	Conclusions	46
Annex A:	Simulation model	47
A.1	General assumption	47
A.2	CoMP assumption for evaluation	49
A.3	Detailed simulation results	49
Annex B:	Latency performance of Rel-8	50
B.1	C-plane latency	50
B.1.1	Transition IDLE to CONNECTED	50
B.1.1.1	FDD frame structure	50
B.1.1.2	TDD frame structure	51
B.1.2	Transition Dormant to Active	52
B.1.2.1	FDD frame structure	53
B.1.2.1.1	Uplink initiated transition, synchronized	53
B.1.2.1.2	Uplink initiated transition, unsynchronized	53
B.1.2.1.3	Downlink initiated transition, synchronized	53
B.1.2.1.4	Downlink initiated transition, unsynchronized	53
B.1.2.2	TDD frame structure	54
B.1.2.2.1	Uplink initiated transition, synchronized	54
B.1.2.2.2	Uplink initiated transition, unsynchronized	54
B.1.2.2.3	Downlink initiated transition, synchronized	55
B.1.2.2.4	Downlink initiated transition, unsynchronized	55
B.2	U-plane latency	56
B.2.1	FDD frame structure	56
B.2.2	TDD frame structure	57
Annex C:	ITU-R Submission Templates	60
C.1	Description template – characteristics (4.2.3.2)	60
C.2	Description template – link budget (4.2.3.3)	60
C.3	Compliance templates for services (4.2.4.1), for spectrum (4.2.4.2), technical performance (4.2.4.3)	60
Annex D:	Change history	61

Foreword

This Technical Report has been produced by the 3rd Generation Partnership Project (3GPP).

The contents of the present document are subject to continuing work within the TSG and may change following formal TSG approval. Should the TSG modify the contents of the present document, it will be re-released by the TSG with an identifying change of release date and an increase in version number as follows:

Version x.y.z

where:

- x the first digit:
 - 1 presented to TSG for information;
 - 2 presented to TSG for approval;
 - 3 or greater indicates TSG approved document under change control.
- y the second digit is incremented for all changes of substance, i.e. technical enhancements, corrections, updates, etc.
- z the third digit is incremented when editorial only changes have been incorporated in the document.

1 Scope

This document is related to the technical report for the study item "Further advancements for E-UTRA" [1].

This activity involves the Radio Access work area of the 3GPP studies and has impacts both on the Mobile Equipment and Access Network of the 3GPP systems.

This document is intended to gather all technical outcome of the study item, and draw a conclusion on way forward.

In addition this document includes the results of the work supporting the 3GPP submission of "LTE Release 10 & beyond (LTE-Advanced)" to the ITU-R as a candidate technology for the IMT-Advanced.

2 References

The following documents contain provisions which, through reference in this text, constitute provisions of the present document.

- References are either specific (identified by date of publication, edition number, version number, etc.) or non-specific.
- For a specific reference, subsequent revisions do not apply.
- For a non-specific reference, the latest version applies. In the case of a reference to a 3GPP document (including a GSM document), a non-specific reference implicitly refers to the latest version of that document *in the same Release as the present document*.

- [1] Contribution to 3GPP TSG RAN meeting #45 RP-090735: "Revised SID on LTE-Advanced".
- [2] 3GPP TR 21.905: "Vocabulary for 3GPP Specifications".
- [3] 3GPP TR 36.913: "Requirements for Evolved UTRA (E-UTRA) and Evolved UTRAN (E-UTRAN)".
- [4] 3GPP TS 23.203: "Policy and charging control architecture".
- [5] 3GPP TS 36.101: "User Equipment (UE) radio transmission and reception".
- [6] 3GPP TS 36.104: "Base Station (BS) radio transmission and reception".
- [7] Report ITU-R M.2133: "Requirements, evaluation criteria and submission templates for the development of IMT-Advanced" (Approved 2008-11).
- [8] Report ITU-R M.2134: "Requirements related to technical performance for IMT-Advanced radio interface(s)" (Approved 2008-11).
- [9] Report ITU-R M.2135: "Guidelines for evaluation of radio interface technologies for IMT-Advanced" (Approved 2008-11).
- [10] Document ITU-R IMT-ADV/3: "Correction of typographical errors and provision of missing texts of IMT-Advanced channel models in Report ITU-R M.2135" (July 2009).
- [11] Document ITU-R IMT-ADV/2 Rev 1: "Submission and evaluation process and consensus building" (Approved 2008-10).
- [12] 3GPP TS 36.213: "Evolved Universal Terrestrial Radio Access (E-UTRA); Physical layer procedures".
- [13] Contribution to 3GPP TSG RAN meeting #45 RP-090744: "TR36.912 Annex A3: Self evaluation results".
- [14] Contribution to 3GPP TSG RAN meeting #45 RP-090745: "TR36.912 Annex C1: Updated characteristics template".

- [15] Contribution to 3GPP TSG RAN meeting #45 RP-090746: "TR36.912 Annex C2: Link budget template".
- [16] Contribution to 3GPP TSG RAN meeting #45 RP-090747: "TR36.912 Annex C3: Compliance template".
- [17] 3GPP TS 36.133: "Evolved Universal Terrestrial Radio Access (E-UTRA); Requirements for support of radio resource management".
- [18] 3GPP TR 36.814: "Feasibility study for Further Advancements for E-UTRA (LTE-Advanced)"

Note: The RAN meeting contributions referenced above are provided with the present Technical Report.

3 Definitions, symbols and abbreviations

3.1 Definitions

For the purposes of the present document, the terms and definitions given in TR 21.905 [2] apply.

3.2 Symbols

Void

3.3 Abbreviations

For the purposes of the present document, the abbreviations defined in 3GPP TS 21.905 [2] and the following apply:

CoMP	Coordinated MultiPoint
MBMS	Multimedia Broadcast/Multicast Service
MU-MIMO	Multi User Multiple Input Multiple Output
RIT	Radio Interface Technology
SON	Self Organising Networks
SRIT	Set of Radio Interface Technologies
SU-MIMO	Single User Multiple Input Multiple Output

4 Introduction

At the 3GPP TSG RAN #39 meeting, the Study Item description on "Further Advancements for E-UTRA (LTE-Advanced)" was approved [1]. The study item covers technology components to be considered for the evolution of E-UTRA, e.g. to fulfil the requirements on IMT-Advanced. This technical report covers all RAN aspects of these technology components.

5 Support of wider bandwidth

5.1 General

LTE-Advanced extends LTE Rel-8 with support for *Carrier Aggregation*, where two or more *component carriers* (CCs) are aggregated in order to support wider transmission bandwidths up to 100MHz and for spectrum aggregation.

It shall be possible to configure all component carriers which are LTE Rel-8 compatible, at least when the aggregated numbers of component carriers in the UL and the DL are the same. Not all component carriers may necessarily be LTE Rel-8 compatible.

A terminal may simultaneously receive or transmit one or multiple component carriers depending on its capabilities:

- An LTE-Advanced terminal with reception and/or transmission capabilities for carrier aggregation can simultaneously receive and/or transmit on multiple component carriers.
- An LTE Rel-8 terminal can receive and transmit on a single component carrier only, provided that the structure of the component carrier follows the Rel-8 specifications.

Carrier aggregation is supported for both contiguous and non-contiguous component carriers with each component carrier limited to a maximum of 110 Resource Blocks in the frequency domain using the LTE Rel-8 numerology

It is possible to configure a UE to aggregate a different number of component carriers originating from the same eNB and of possibly different bandwidths in the UL and the DL. In typical TDD deployments, the number of component carriers and the bandwidth of each component carrier in UL and DL will be the same.

Component carriers originating from the same eNB need not to provide the same coverage.

The spacing between centre frequencies of contiguously aggregated component carriers shall be a multiple of 300 kHz. This is in order to be compatible with the 100 kHz frequency raster of LTE Rel-8 and at the same time preserve orthogonality of the subcarriers with 15 kHz spacing. Depending on the aggregation scenario, the $n \cdot 300$ kHz spacing can be facilitated by insertion of a low number of unused subcarriers between contiguous component carriers.

5.1A Physical layer

5.1A.1 DL control signalling

The design principles for downlink control signalling of control region size, uplink and downlink resource assignments, and downlink HARQ ACK/NACK indication are described below.

- Independent control region size is applied for each component carrier. On any carrier with a control region, Rel-8 design (modulation, coding, mapping to resource elements) for PCFICH is reused.
- For signalling of resource assignments for downlink (PDSCH) and uplink (PUSCH) transmission, following mechanisms are supported,
 - PDCCH on a component carrier assigns PDSCH resources on the same component carrier and PUSCH resources on a single linked UL component carrier. Rel-8 PDCCH structure (same coding, same CCE-based resource mapping) and DCI formats are used on each component carrier.
 - PDCCH on a component carrier can assign PDSCH or PUSCH resources in one of multiple component carriers using the carrier indicator field, where Rel-8 DCI formats are extended with 1 – 3 bit carrier indicator field, and Rel-8 PDCCH structure (same coding, same CCE-based resource mapping) is reused.

where the presence of carrier indicator field is semi-statically configured.

- For signalling of downlink HARQ ACK/NACK indication, following principles are applied.
 - PHICH physical transmission aspects from Rel-8 (orthogonal code design, modulation, scrambling sequence, mapping to resource elements) are reused.
 - PHICH is transmitted only on the downlink component carrier that was used to transmit the UL grant
 - At least in case that the number of downlink component carriers are more than or equal to that of uplink component carriers and no carrier indicator field is used, the Rel-8 PHICH resource mapping rule is reused.

5.1A.2 UL control signalling

The design principles for uplink control signalling of HARQ ACK/NACK, scheduling request and channel state information (CSI) on PUCCH are described below.

- The Rel-10 PUCCH design supports up to five DL component carriers.
- For signalling of HARQ ACK/NACK on PUCCH for downlink (PDSCH) transmission, following mechanisms are supported:

- All HARQ ACK/NACK for a UE can be transmitted on PUCCH in absence of PUSCH transmission.
- In general, transmission of one ACK/NACK for each DL component carrier transport block is supported.
- In case of power limitation, limited transmission of ACK/NACK for the DL component carrier transport blocks is supported.
- The design of the ACK/NACK resource allocation should consider performance and power control aspects, while not aiming to optimise for the case of large number of UEs being simultaneously scheduled on multiple DL component carriers.
- The scheduling request is transmitted on PUCCH and is semi-statically mapped onto one UE specific UL component carrier.
- Periodic CSI reporting on PUCCH is supported for up to five DL component carriers. The CSI is semi-statically mapped onto one UE specific UL component carrier and the design follows the Rel-8 principles for CQI/PMI/RI, considering ways to reduce reporting overhead or to extend CSI payload.

5.2 User Plane

5.2.1 Structure

Compared to the Layer 2 structure of LTE Rel-8, the multi-carrier nature of the physical layer is only exposed to the MAC layer for which one HARQ entity is required per CC. The Layer 2 structure for the downlink is depicted on Figure 5.2.1-1 below.

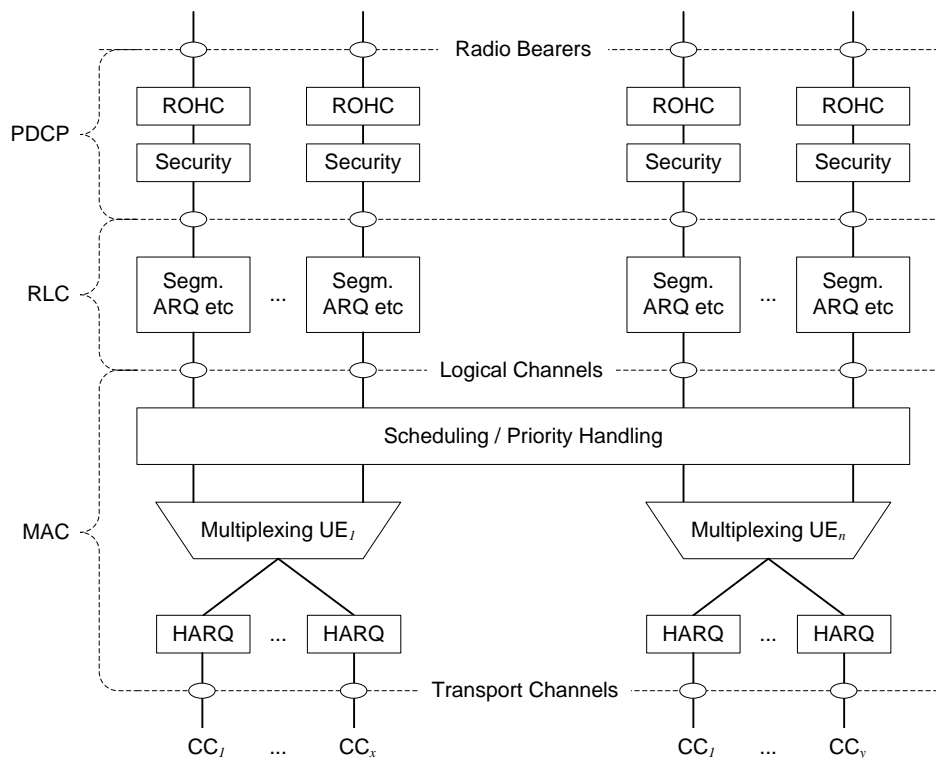

Figure 5.2.1-1: Layer 2 Structure for the DL

The Layer 2 structure for the uplink is depicted on Figure 5.2.1-2 below.

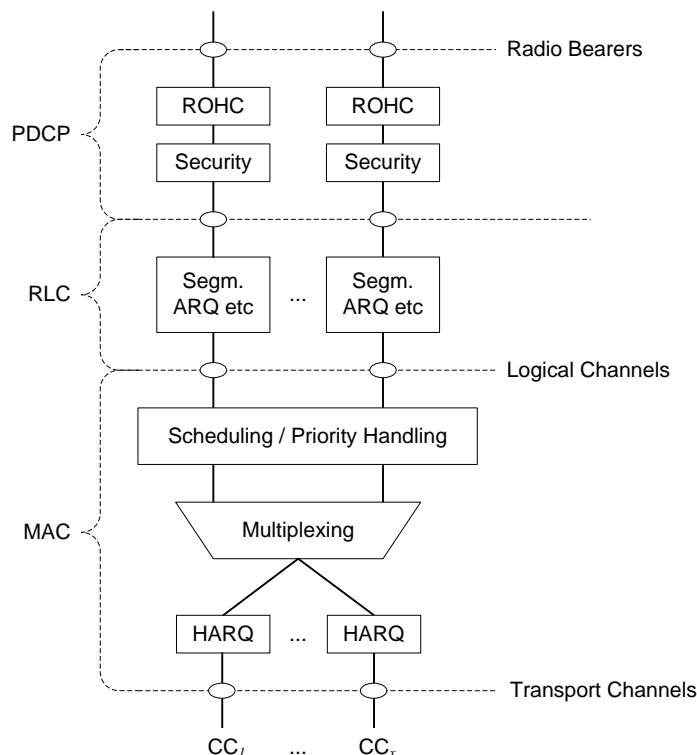

Figure 5.2.1-2: Layer 2 Structure for the UL

5.2.2 MAC

From a UE perspective, the Layer 2 aspects of HARQ are kept Rel-8 compliant unless modifications provide significant gains. There is one transport block (in absence of spatial multiplexing, up to two transport blocks in case of spatial multiplexing) and one independent hybrid-ARQ entity per scheduled component carrier. Each transport block is mapped to a single component carrier only where all possible HARQ retransmissions also take place. A UE may be scheduled over multiple component carriers simultaneously but at most one random access procedure shall be ongoing at any time.

Whenever a UE is configured with only one CC, Rel-9 DRX is the baseline. In other cases, the baseline is that the same DRX operation applies to all configured CCs (i.e. identical active time for PDCCH monitoring). When in active time, any CC may always schedule PDSCH on any other configured (and possibly activated, FFS) CC.

5.2.3 RLC

The RLC protocol of LTE Rel-8 also applies to carrier aggregation and allows LTE-A to handle data rate up to 1Gbps. Further enhancements (e.g. increased RLC SN size) can be considered.

5.2.4 PDCP

The PDCP protocol of LTE Rel-8 also applies to carrier aggregation. Further enhancements (e.g. increased PDCP SN size) can be considered.

5.3 Control plane

5.3.1 Structure

The C-Plane architecture of LTE Rel-8 also applies to carrier aggregation.

5.3.2 RRC procedures

5.3.2.1 System Information

A cell is identified by a unique ECGI and corresponds to the transmission of system information in one CC. Rel-8 relevant system information and possible extensions for LTE-A are delivered on “backward compatible” CCs. Each CC provides on BCCH the system information which is specific to it. The handling of system information for extension carriers is FFS.

5.3.2.2 Connection Control

As in LTE Rel-8, the UE only has one RRC connection with the network. One cell - the “special cell” - provides the security input (one ECGI, one PCI and one ARFCN) and the NAS mobility information (e.g. TAI). There is only one “special cell” per UE in connected mode.

After RRC connection establishment to the “special cell”, the reconfiguration, addition and removal of CCs can be performed by *RRCConnectionReconfiguration* including *mobilityControlInfo* (i.e. “intra-cell handover”). *RRCConnectionReconfiguration* without *mobilityControlInfo* can also be used for the addition of CCs, and for the removal of CCs with the exception of the CC corresponding to the “special cell”.

At intra-LTE handover, the *RRCConnectionReconfiguration* with *mobilityControlInfo* (i.e. “handover command”) can remove, reconfigure or add CCs for usage in the target cell.

When adding a new CC, dedicated RRC signalling is used for sending CCs’ system information which is necessary for CC transmission/reception (similarly as in Rel-8 for handover).

Detection of failure of one CC by the UE does not necessarily trigger a connection re-establishment. RRC connection re-establishment triggers at the UE include:

- 1) The failure of all CCs on which the UE is configured to receive PDCCH;

NOTE: FFS if re-establishment is triggered under more restrictive conditions (e.g. in case of problems on a smaller subset of CC’s).

- 2) The loss of all UL communication;

NOTE: The conditions under which all UL communications are said to be lost are FFS.

- 3) The indication from RLC that the maximum number of retransmissions has been reached (as in Rel-8).

5.3.2.3 Measurements

UE sees a CC as any other carrier frequency and a measurement object needs to be set up for a CC in order for the UE to measure it. Inter-frequency neighbour measurements (for which no serving cell is defined for measurement purposes) encompass all the carrier frequencies which are not configured as CCs.

5.3.3 Idle mode procedures

Idle mode mobility procedures of LTE Rel-8 also apply in a network deploying carrier aggregation. It should be possible for a network to configure only a subset of CCs for idle mode camping.

6 Uplink transmission scheme

6.1 Uplink spatial multiplexing

LTE-Advanced extends LTE Rel-8 with support for uplink spatial multiplexing of up to four layers.

In case of uplink single-user spatial multiplexing, up to two transport blocks can be transmitted from a scheduled UE in a subframe per uplink component carrier. Each transport block has its own MCS level. Depending on the number of transmission layers, the modulation symbols associated with each of the transport blocks are mapped onto one or two layers according to the same principle as for LTE Rel-8 downlink spatial multiplexing. The transmission rank can be adapted dynamically. It is possible to configure the uplink single-user spatial-multiplexing transmission with or without the layer shifting. In case of the layer shifting, shifting in time domain is supported.

If layer shifting is configured, the HARQ-ACKs for all transport blocks are bundled into a single HARQ-ACK. One-bit ACK is transmitted to the UE if all transport blocks are successfully decoded by the eNodeB. Otherwise, one-bit NACK is transmitted to the UE.

If layer shifting is not configured, each transport block has its own HARQ-ACK feedback signalling.

For FDD and TDD, precoding is performed according to a predefined codebook. If layer shifting is not configured, precoding is applied after the layer mapping. If layer shifting is configured, precoding is applied after the layer shifting operation. Application of a single precoding matrix per uplink component carrier is supported. In case of full-rank transmission, only identity precoding matrix is supported. For uplink spatial multiplexing with two transmit antennas, 3-bit precoding codebook as defined in Table 6.1-1 is used.

Table 6.1-1: 3-bit precoding codebook for uplink spatial multiplexing with two transmit antennas

Codebook index	Number of layers ν	
	1	2
0	$\frac{1}{\sqrt{2}} \begin{bmatrix} 1 \\ 1 \end{bmatrix}$	$\frac{1}{\sqrt{2}} \begin{bmatrix} 1 & 0 \\ 0 & 1 \end{bmatrix}$
1	$\frac{1}{\sqrt{2}} \begin{bmatrix} 1 \\ -1 \end{bmatrix}$	
2	$\frac{1}{\sqrt{2}} \begin{bmatrix} 1 \\ j \end{bmatrix}$	
3	$\frac{1}{\sqrt{2}} \begin{bmatrix} 1 \\ -j \end{bmatrix}$	-
4	$\frac{1}{\sqrt{2}} \begin{bmatrix} 1 \\ 0 \end{bmatrix}$	
5	$\frac{1}{\sqrt{2}} \begin{bmatrix} 0 \\ 1 \end{bmatrix}$	

For uplink spatial multiplexing with four transmit antennas, 6-bit precoding codebook is used. The subset of the precoding codebook used for 1-layer transmission is defined in Table 6.1-2. The baseline for the subset of the precoding codebook used for 2-layer transmission is defined in Table 6.1-3. For 3-layer transmission, the number of precoding matrices is 20, and only BPSK or QPSK alphabets are used for non-zero elements in precoding matrices.

Table 6.1-2: 6-bit precoding codebook for uplink spatial multiplexing with four transmit antennas: precoding matrices for 1-layer transmission.

	Codebook							
Index	$\frac{1}{2} \begin{bmatrix} 1 \\ 1 \\ 1 \\ -1 \end{bmatrix}$	$\frac{1}{2} \begin{bmatrix} 1 \\ 1 \\ j \\ j \end{bmatrix}$	$\frac{1}{2} \begin{bmatrix} 1 \\ 1 \\ -1 \\ 1 \end{bmatrix}$	$\frac{1}{2} \begin{bmatrix} 1 \\ 1 \\ -j \\ -j \end{bmatrix}$	$\frac{1}{2} \begin{bmatrix} 1 \\ j \\ 1 \\ j \end{bmatrix}$	$\frac{1}{2} \begin{bmatrix} 1 \\ j \\ j \\ 1 \end{bmatrix}$	$\frac{1}{2} \begin{bmatrix} 1 \\ j \\ -1 \\ -j \end{bmatrix}$	$\frac{1}{2} \begin{bmatrix} 1 \\ j \\ -j \\ -1 \end{bmatrix}$
0 to 7								

Index 8 to 15	$\frac{1}{2} \begin{bmatrix} 1 \\ -1 \\ 1 \\ 1 \end{bmatrix}$	$\frac{1}{2} \begin{bmatrix} 1 \\ -1 \\ j \\ -j \end{bmatrix}$	$\frac{1}{2} \begin{bmatrix} 1 \\ -1 \\ -1 \\ -1 \end{bmatrix}$	$\frac{1}{2} \begin{bmatrix} 1 \\ -1 \\ -j \\ j \end{bmatrix}$	$\frac{1}{2} \begin{bmatrix} 1 \\ -j \\ 1 \\ -j \end{bmatrix}$	$\frac{1}{2} \begin{bmatrix} 1 \\ -j \\ j \\ -1 \end{bmatrix}$	$\frac{1}{2} \begin{bmatrix} 1 \\ -j \\ -1 \\ j \end{bmatrix}$	$\frac{1}{2} \begin{bmatrix} 1 \\ -j \\ -j \\ 1 \end{bmatrix}$
Index 16 to 23	$\frac{1}{2} \begin{bmatrix} 1 \\ 0 \\ 1 \\ 0 \end{bmatrix}$	$\frac{1}{2} \begin{bmatrix} 1 \\ 0 \\ -1 \\ 0 \end{bmatrix}$	$\frac{1}{2} \begin{bmatrix} 1 \\ 0 \\ j \\ 0 \end{bmatrix}$	$\frac{1}{2} \begin{bmatrix} 1 \\ 0 \\ -j \\ 0 \end{bmatrix}$	$\frac{1}{2} \begin{bmatrix} 0 \\ 1 \\ 0 \\ 1 \end{bmatrix}$	$\frac{1}{2} \begin{bmatrix} 0 \\ 1 \\ 0 \\ -1 \end{bmatrix}$	$\frac{1}{2} \begin{bmatrix} 0 \\ 1 \\ 1 \\ j \end{bmatrix}$	$\frac{1}{2} \begin{bmatrix} 0 \\ 1 \\ 1 \\ -j \end{bmatrix}$

Table 6.1-3: 6-bit precoding codebook for uplink spatial multiplexing with four transmit antennas: precoding matrices for 2-layer transmission.

	Codebook							
Index 0 to 7	$\frac{1}{2} \begin{bmatrix} 1 & 0 \\ 1 & 0 \\ 0 & 1 \\ 0 & -j \end{bmatrix}$	$\frac{1}{2} \begin{bmatrix} 1 & 0 \\ 1 & 0 \\ 0 & 1 \\ 0 & j \end{bmatrix}$	$\frac{1}{2} \begin{bmatrix} 1 & 0 \\ -j & 0 \\ 0 & 1 \\ 0 & 1 \end{bmatrix}$	$\frac{1}{2} \begin{bmatrix} 1 & 0 \\ -j & 0 \\ 0 & 1 \\ 0 & -1 \end{bmatrix}$	$\frac{1}{2} \begin{bmatrix} 1 & 0 \\ -1 & 0 \\ 0 & 1 \\ 0 & -j \end{bmatrix}$	$\frac{1}{2} \begin{bmatrix} 1 & 0 \\ -1 & 0 \\ 0 & 1 \\ 0 & j \end{bmatrix}$	$\frac{1}{2} \begin{bmatrix} 1 & 0 \\ j & 0 \\ 0 & 1 \\ 0 & 1 \end{bmatrix}$	$\frac{1}{2} \begin{bmatrix} 1 & 0 \\ j & 0 \\ 0 & 1 \\ 0 & -1 \end{bmatrix}$
Index 8 to 15	$\frac{1}{2} \begin{bmatrix} 1 & 0 \\ 0 & 1 \\ 1 & 0 \\ 0 & 1 \end{bmatrix}$	$\frac{1}{2} \begin{bmatrix} 1 & 0 \\ 0 & 1 \\ 1 & 0 \\ 0 & -1 \end{bmatrix}$	$\frac{1}{2} \begin{bmatrix} 1 & 0 \\ 0 & 1 \\ -1 & 0 \\ 0 & 1 \end{bmatrix}$	$\frac{1}{2} \begin{bmatrix} 1 & 0 \\ 0 & 1 \\ -1 & 0 \\ 0 & -1 \end{bmatrix}$	$\frac{1}{2} \begin{bmatrix} 1 & 0 \\ 0 & 1 \\ 0 & 1 \\ 1 & 0 \end{bmatrix}$	$\frac{1}{2} \begin{bmatrix} 1 & 0 \\ 0 & 1 \\ 0 & -1 \\ 1 & 0 \end{bmatrix}$	$\frac{1}{2} \begin{bmatrix} 1 & 0 \\ 0 & 1 \\ 0 & 1 \\ -1 & 0 \end{bmatrix}$	$\frac{1}{2} \begin{bmatrix} 1 & 0 \\ 0 & 1 \\ 0 & -1 \\ -1 & 0 \end{bmatrix}$

6.1A Uplink transmit diversity

For UEs with multiple transmit antennas, an uplink Single Antenna Port Mode is defined, where the UE behaviour is same as the one with single antenna from eNodeB's perspective. For a given UE, the uplink Single Antenna Port Mode can be independently configured for its PUCCH, PUSCH and SRS transmissions.

The uplink Single Antenna Port Mode is the default mode before eNodeB is aware of the UE transmit antenna configuration.

6.1A.1 Transmit Diversity for Uplink Control Channel

For uplink control channels with Rel-8 PUCCH format 1/1a/1b, the spatial orthogonal-resource transmit diversity (SORTD) scheme is supported for transmissions with two antenna ports. In this transmit diversity scheme, the same modulation symbol from the uplink channel is transmitted from two antenna ports, on two separate orthogonal resources.

For the UE with four transmit antennas, the 2-tx transmit diversity scheme is applied.

6.2 Uplink multiple access

DFT-precoded OFDM is the transmission scheme used for PUSCH both in absence and presence of spatial multiplexing. In case of multiple component carriers, there is one DFT per component carrier. Both frequency-contiguous and frequency-non-contiguous resource allocation is supported on each component carrier.

Simultaneous transmission of uplink L1/L2 control signalling and data is supported through two mechanisms

- Control signalling is multiplexed with data on PUSCH according to the same principle as in LTE Rel-8
- Control signalling is transmitted on PUCCH simultaneously with data on PUSCH

6.3 Uplink reference signals

LTE Advanced retains the basic uplink reference-signal structure of LTE Rel-8, with two types of uplink reference signals:

- Demodulation reference signal
- Sounding reference signal

In case of uplink multi-antenna transmission, the precoding applied for the demodulation reference signal is the same as the one applied for the PUSCH. Cyclic shift separation is the primary multiplexing scheme of the demodulation reference signals.

The baseline for sounding reference signal in LTE-Advanced operation is non-precoded and antenna-specific. For multiplexing of the sounding reference signals, the LTE Rel-8 principles are reused.

6.4 Uplink power control

Scope of uplink power control in LTE-Advanced is similar to Rel-8:

- UL power control mainly compensates for slow-varying channel conditions while reducing the interference generated towards neighboring cells
- Fractional path-loss compensation or full path-loss compensation is used on PUSCH and full path-loss compensation on PUCCH

LTE-Advanced supports component carrier specific UL power control for both contiguous and non-contiguous carrier aggregation for closed-loop case, and for open loop at least for the cases that the number of downlink component carriers is more than or equal to that of uplink component carriers.

7 Downlink transmission scheme

7.0 Physical channel mapping

LTE-Advanced supports the PDSCH to be mapped also to MBSFN (non-control) region of MBSFN subframes that are not used for MBMS

- In case of PDSCH mapping to MBSFN subframes, both normal and extended cyclic prefix can be used for control and data region, same CP length is used for control and data
- Relation between CP length of normal and MBSFN subframes in the control region is the same as in Rel-8

7.1 Downlink spatial multiplexing

LTE-Advanced extends LTE Rel-8 downlink spatial multiplexing with support for up to eight layers spatial multiplexing

In the downlink 8-by-X single user spatial multiplexing, up to two transport blocks can be transmitted to a scheduled UE in a subframe per downlink component carrier. Each transport block is assigned its own modulation and coding scheme. For HARQ ACK/NAK feedback on uplink, one bit is used for each transport block.

A transport block is associated with a codeword. For up to four layers, the codeword-to-layer mapping is the same as for LTE Rel-8. For more than four layers as well as the case of mapping one codeword to three or four layers, which is for retransmission of one out of two codewords that were initially transmitted with more than four layers, the layer mapping shall be done according to Table 7.1-1. Complex-valued modulation symbols for code word shall be mapped onto the layers, where L is the number of layers and M_{symb} is the number of modulation symbols per layer.

Table 7.1-1: Codeword-to-layer mapping for above four layers and the case of mapping one codeword to three or four layers

Number of layers	Number of code words	Codeword-to-layer mapping $i = 0, 1, \dots, M_{\text{symb}}^{\text{layer}} - 1$
3	1	$\begin{aligned} x^{(0)}(i) &= d^{(0)}(3i) \\ x^{(1)}(i) &= d^{(0)}(3i+1) \\ x^{(2)}(i) &= d^{(0)}(3i+2) \end{aligned} \quad M_{\text{symb}}^{\text{layer}} = M_{\text{symb}}^{(0)} / 3$
4	1	$\begin{aligned} x^{(0)}(i) &= d^{(0)}(4i) \\ x^{(1)}(i) &= d^{(0)}(4i+1) \\ x^{(2)}(i) &= d^{(0)}(4i+2) \\ x^{(3)}(i) &= d^{(0)}(4i+3) \end{aligned} \quad M_{\text{symb}}^{\text{layer}} = M_{\text{symb}}^{(0)} / 4$
5	2	$\begin{aligned} x^{(0)}(i) &= d^{(0)}(2i) \\ x^{(1)}(i) &= d^{(0)}(2i+1) \\ x^{(2)}(i) &= d^{(1)}(3i) \\ x^{(3)}(i) &= d^{(1)}(3i+1) \\ x^{(4)}(i) &= d^{(1)}(3i+2) \end{aligned} \quad M_{\text{symb}}^{\text{layer}} = M_{\text{symb}}^{(0)} / 2 = M_{\text{symb}}^{(1)} / 3$
6	2	$\begin{aligned} x^{(0)}(i) &= d^{(0)}(3i) \\ x^{(1)}(i) &= d^{(0)}(3i+1) \\ x^{(2)}(i) &= d^{(0)}(3i+2) \\ x^{(3)}(i) &= d^{(1)}(3i) \\ x^{(4)}(i) &= d^{(1)}(3i+1) \\ x^{(5)}(i) &= d^{(1)}(3i+2) \end{aligned} \quad M_{\text{symb}}^{\text{layer}} = M_{\text{symb}}^{(0)} / 3 = M_{\text{symb}}^{(1)} / 3$
7	2	$\begin{aligned} x^{(0)}(i) &= d^{(0)}(3i) \\ x^{(1)}(i) &= d^{(0)}(3i+1) \\ x^{(2)}(i) &= d^{(0)}(3i+2) \\ x^{(3)}(i) &= d^{(1)}(4i) \\ x^{(4)}(i) &= d^{(1)}(4i+1) \\ x^{(5)}(i) &= d^{(1)}(4i+2) \\ x^{(6)}(i) &= d^{(1)}(4i+3) \end{aligned} \quad M_{\text{symb}}^{\text{layer}} = M_{\text{symb}}^{(0)} / 3 = M_{\text{symb}}^{(1)} / 4$
8	2	$\begin{aligned} x^{(0)}(i) &= d^{(0)}(4i) \\ x^{(1)}(i) &= d^{(0)}(4i+1) \\ x^{(2)}(i) &= d^{(0)}(4i+2) \\ x^{(3)}(i) &= d^{(0)}(4i+3) \\ x^{(4)}(i) &= d^{(1)}(4i) \\ x^{(5)}(i) &= d^{(1)}(4i+1) \\ x^{(6)}(i) &= d^{(1)}(4i+2) \\ x^{(7)}(i) &= d^{(1)}(4i+3) \end{aligned} \quad M_{\text{symb}}^{\text{layer}} = M_{\text{symb}}^{(0)} / 4 = M_{\text{symb}}^{(1)} / 4$

7.1.1 Feedback in support of downlink spatial multiplexing

The baseline for feedback in support of downlink single-cell single-user spatial multiplexing is codebook-based precoding feedback.

7.2 Downlink reference signals

LTE-Advanced extends the downlink reference-signal structure of LTE with

- Reference signals targeting PDSCH demodulation

- Reference signals targeting CSI estimation (for CQI/PMI/RI/etc reporting when needed)

The reference signal structure can be used to support multiple LTE-Advanced features, e.g. CoMP and spatial multiplexing.

The reference signals targeting PDSCH demodulation are:

- UE-specific, i.e. the PDSCH and the demodulation reference signals intended for a specific UE are subject to the same precoding operation.
- Present only in resource blocks and layers scheduled by the eNodeB for transmission.
- Mutually orthogonal between layers at the eNodeB.

The design principle for the reference signals targeting PDSCH modulation is an extension to multiple layers of the concept of Rel-8 UE-specific reference signals used for beamforming. Complementary use of Rel-8 cell-specific reference signals by the UE is not precluded.

Reference signals targeting CSI estimation are

- cell specific
- sparse in frequency and time
- punctured into the data region of normal/MBSFN subframe.

7.3 Downlink transmit diversity

For the downlink transmit diversity with more than four transmit antennas applied to PDCCH, and PDSCH in non-MBSFN subframes, the Rel-8 transmit diversity scheme is used.

8 Coordinated multiple point transmission and reception

Coordinated multi-point (CoMP) transmission/reception is considered for LTE-Advanced as a tool to improve the coverage of high data rates, the cell-edge throughput and/or to increase system throughput.

8.1 Downlink coordinated multi-point transmission

Downlink coordinated multi-point transmission (CoMP) is a relatively general term referring to different types of coordination in the downlink transmission from multiple geographically separated transmission points (TP). This includes coordination in the scheduling, including any beam-forming functionality, between geographically separated transmission points and joint transmission from geographically separated transmission points.

8.2 Uplink coordinated multi-point reception

Uplink CoMP reception is a relatively general term referring to different types of coordination in the uplink reception at multiple, geographically separated points. This includes coordination in the scheduling, including any beam-forming functionality, between geographically separated reception points.

9 Relaying

9.1 General

LTE-Advanced extends LTE Rel-8 with support for relaying as a tool to improve e.g. the coverage of high data rates, group mobility, temporary network deployment, the cell-edge throughput and/or to provide coverage in new areas.

The relay node (RN) is wirelessly connected to a *donor cell* of a *donor eNB* via the Un interface, and UEs connect to the RN via the Uu interface as shown on Figure 9.1-1 below.

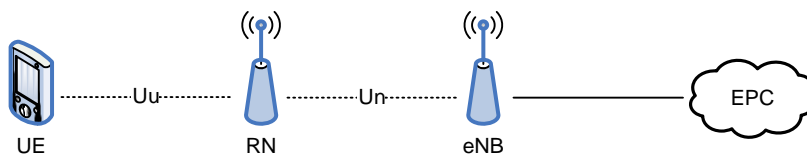

Figure 9.1-1: Relays

With respect to the relay node's usage of spectrum, its operation can be classified into:

- *inband*, in which case the eNB-RN link shares the same carrier frequency with RN-UE links. Rel-8 UEs should be able to connect to the donor cell in this case.
- *outband*, in which case the eNB-RN link does not operate in the same carrier frequency as RN-UE links. Rel-8 UEs should be able to connect to the donor cell in this case.

For both inband and outband relaying, it shall be possible to operate the eNB-to-relay link on the same carrier frequency as eNB-to-UE links.

At least "Type 1" and "Type 1a" RNs are supported by LTE-Advanced.

A "Type 1" RN is an inband RN characterized by the following:

- It controls cells, each of which appears to a UE as a separate cell distinct from the donor cell
- The cells shall have their own Physical Cell ID (as defined in LTE Rel-8) and transmit their own synchronization channels, reference symbols, ...
- In the context of single-cell operation, the UE receives scheduling information and HARQ feedback directly from the RN and sends its control channels (SR/CQI/ACK) to the RN
- It shall appear as a Rel-8 eNodeB to Rel-8 UEs (i.e. be backwards compatible)
- To LTE-Advanced UEs, it should be possible for a relay node to appear differently than Rel-8 eNodeB to allow for further performance enhancement.

A "Type 1a" relay node is characterised by the same set of features as the "Type 1" relay node above, except "Type 1a" operates outband.

9.2 Architecture

On Uu interface between UE and RN, all AS control plane (RRC) and user plane (PDCP, RLC and MAC) protocols are terminated in RN. On Un interface between RN and eNB, the user plane is based on standardised protocols (PDCP, RLC, MAC). The control plane on Un uses RRC (for the RN in its role as UE).

9.3 Relay-eNodeB link for inband relay

9.3.1 Resource partitioning for relay-eNodeB link

In order to allow inband relaying, some resources in the time-frequency space are set aside for the backhaul link (Un) and cannot be used for the access link (Uu). At least the following scheme is supported for this resource partitioning:

Resource partitioning at the RN:

- in the downlink, eNB → RN and RN → UE links are time division multiplexed in a single carrier frequency (only one is active at any time)

- in the uplink, UE → RN and RN → eNB links are time division multiplexed in a single carrier frequency (only one is active at any time)

Multiplexing of backhaul links in FDD:

- eNB → RN transmissions are done in the DL frequency band
- RN → eNB transmissions are done in the UL frequency band

Multiplexing of backhaul links in TDD:

- eNB → RN transmissions are done in the DL subframes of the eNB and RN
- RN → eNB transmissions are done in the UL subframes of the eNB and RN

9.3.2 Backward compatible backhaul partitioning

Due to the relay transmitter causing interference to its own receiver, simultaneous eNodeB-to-relay and relay-to-UE transmissions on the same frequency resource may not be feasible unless sufficient isolation of the outgoing and incoming signals is provided. Similarly, at the relay it may not be possible to receive UE transmissions simultaneously with the relay transmitting to the eNodeB.

One way to handle the interference problem is to operate the relay such that the relay is not transmitting to terminals when it is supposed to receive data from the donor eNodeB, i.e. to create "gaps" in the relay-to-UE transmission. These "gaps" during which terminals (including Rel-8 terminals) are not supposed to expect any relay transmission can be created by configuring MBSFN subframes as exemplified in Figure 9.1. Relay-to-eNodeB transmissions can be facilitated by not allowing any terminal-to-relay transmissions in some subframes.

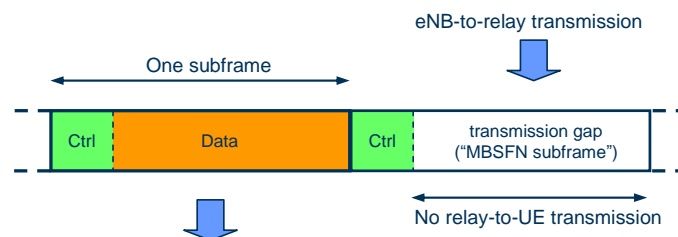

Figure 9.1: Example of relay-to-UE communication using normal subframes (left) and eNodeB-to-relay communication using MBSFN subframes (right).

9.3.3 Backhaul resource assignment

In case of downlink backhaul in downlink resources, the following is valid

- At the RN, the access link downlink subframe boundary is aligned with the backhaul link downlink subframe boundary, except for possible adjustment to allow for RN transmit/receive switching
- The set of downlink backhaul subframes, during which downlink backhaul transmission may occur, is semi-statically assigned.
- The set of uplink backhaul subframes, during which uplink backhaul transmission may occur, can be semi-statically assigned, or implicitly derived from the downlink backhaul subframes using the HARQ timing relationship
- A new physical control channel (the R-PDCCH) is used to dynamically or semi-persistently assign resources, within the semi-statically assigned sub-frames, for the downlink backhaul data (corresponding to the R-PDSCH physical channel). The R-PDCCH may assign downlink resources in the same and/or in one or more later subframes.
- The R-PDCCH is also used to dynamically or semi-persistently assign resources for the uplink backhaul data (the R-PUSCH physical channel). The R-PDCCH may assign uplink resources in one or more later subframes.

- Within the PRBs semi-statically assigned for R-PDCCH transmission, a subset of the resources is used for each R-PDCCH. The actual overall set of resources used for R-PDCCH transmission within the above mentioned semi-statically assigned PRBs may vary dynamically between subframes. These resources may correspond to the full set of OFDM symbols available for the backhaul link or be constrained to a subset of these OFDM symbols. The resources that are not used for R-PDCCH within the above mentioned semi-statically assigned PRBs may be used to carry R-PDSCH or PDSCH.
- The detailed R-PDCCH transmitter processing (channel coding, interleaving, multiplexing, etc.) should reuse Rel-8 functionality to the extent possible, but allow removing some unnecessary procedure or bandwidth-wasting procedure by considering the relay property.
- If the search space approach of Rel-8 is used for the backhaul link, use of common search space, which can be semi-statically configured (and potentially includes entire system bandwidth), is the baseline. If RN-specific search space is configured, it could be implicitly or explicitly known by RN.
- The R-PDCCH is transmitted starting from an OFDM symbol within the subframe that is late enough so that the relay can receive it.
- R-PDSCH and R-PDCCH can be transmitted within the same PRBs or within separated PRBs.

9.4 Relay-eNodeB link for outband relay

If relay-eNB and relay-UE links are isolated enough in frequency (possibly with help of additional means such as antenna separation), then there is no interference issue in activating both links simultaneously. Therefore, it becomes possible for relay-eNodeB link to reuse the channels designed for UE-eNodeB link.

10 Improvement for latency

10.1 Improvement for C-Plane latency

In LTE-Advanced, the transition time requirement from Idle mode (with IP address allocated) to Connected mode is less than 50 ms including the establishment of the user plane (excluding the S1 transfer delay). The transition requirement from a "dormant state" in Connected mode is less than 10 ms.

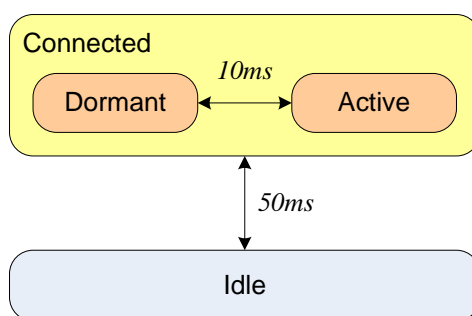

Figure 10.1-1: C-Plane Latency

Although already LTE Rel-8 fulfills the latency requirements of ITU (see Annex B), several mechanisms could be used to further reduce the latency and achieve also the more aggressive LTE-Advanced targets set by 3GPP [3]:

- **Combined RRC Connection Request and NAS Service Request:** combining allows those two messages to be processed in parallel at the eNB and MME respectively, reducing overall latency from Idle mode to Connected mode by approx. 20ms.
- **Reduced processing delays:** processing delays in the different nodes form the major part of the delay (around 75% for the transition from Idle to Connected mode assuming a combined request) so any improvement has a large impact on the overall latency.

- **Reduced RACH scheduling period:** decreasing the RACH scheduling period from 10 ms to 5 ms results in decreasing by 2.5ms the average waiting time for the UE to initiate the procedure to transit from Idle mode to Connected mode.

Regarding the transition from a "dormant state" in Connected mode, the following mechanism could be used in LTE-Advanced to achieve the requirement:

- **Shorter PUCCH cycle:** a shorter cycle of PUCCH would reduce the average waiting time for a synchronised UE to request resources in Connected mode.
- **Contention based uplink:** contention based uplink allows UEs to transmit uplink data without having to first transmit Scheduling Request on PUCCH, thus reducing the access time for synchronized UEs in Connected mode.

10.2 Improvement for U-Plane latency

LTE Rel-8 already benefits from a U-Plane latency below 10ms for synchronised UEs (see Annex B). In situations where the UE does not have a valid scheduling assignment, or when the UE needs to synchronize and obtain a scheduling assignment, a reduced RACH scheduling period, shorter PUCCH cycle, contention based uplink and reduced processing delays as described in subclause 10.1 above could also be used to improve the latency compared to LTE Rel-8.

11 Radio transmission and reception

11.1 RF scenarios

11.1.1 Deployment scenarios

This section reviews deployment scenarios that were considered for initial investigation in a near term time frame. Scenarios are shown in Table 11.1.1-1.

Table 11.1.1-1: Deployment scenarios

Scenario	Proposed initial deployment scenario for investigation
a	Single band contiguous allocation for FDD (UL:40 MHz, DL: 80 MHz)
b	Single band contiguous allocation for TDD (100 MHz)
c	Multi band non-contiguous allocation for FDD (UL:40MHz, DL:40 MHz)
d	Multi band non contiguous allocation for TDD (90 MHz)

11.2 Common requirements for UE and BS

11.2.1 Carrier Aggregation

11.2.1.1 Bandwidth configuration of component carriers

Radio requirements shall be specified for aggregation of component carriers for both contiguous and non-contiguous aggregation. The allowed channel bandwidths for each component carrier are 1.4 MHz, 3.0 MHz, 5MHz, 10 MHz, 15 MHz and 20 MHz.

11.2.1.2 Carrier spacing between component carriers

The carrier spacing between component carriers is a multiple of 300 kHz for contiguous aggregation and non-contiguous aggregation in the same operating band. It shall be possible to configure all component carriers LTE Release 8 compatible, at least when the aggregated numbers of component carriers in the UL and the DL are same. Not all component carriers may necessarily be LTE release 8 compatible.

11.2.2 Operating bands

Operating bands of LTE-Advanced will involve E-UTRA operating bands as well as possible IMT bands identified by ITU-R. E-UTRA is designed to operate in the operating bands as defined in [5, 6]. E-UTRA operating bands are shown in Table 11.2.2-1.

Table 11.2.2-1 Operating bands for LTE-Advanced (E-UTRA operating bands):

Operating Band	Uplink (UL) operating band BS receive/UE transmit		Downlink (DL) operating band BS transmit /UE receive		Duplex Mode
	F _{UL_low}	F _{UL_high}	F _{DL_low}	F _{DL_high}	
1	1920 MHz	1980 MHz	2110 MHz	2170 MHz	FDD
2	1850 MHz	1910 MHz	1930 MHz	1990 MHz	FDD
3	1710 MHz	1785 MHz	1805 MHz	1880 MHz	FDD
4	1710 MHz	1755 MHz	2110 MHz	2155 MHz	FDD
5	824 MHz	849 MHz	869 MHz	894 MHz	FDD
6	830 MHz	840 MHz	865 MHz	875 MHz	FDD
7	2500 MHz	2570 MHz	2620 MHz	2690 MHz	FDD
8	880 MHz	915 MHz	925 MHz	960 MHz	FDD
9	1749.9 MHz	1784.9 MHz	1844.9 MHz	1879.9 MHz	FDD
10	1710 MHz	1770 MHz	2110 MHz	2170 MHz	FDD
11	1427.9 MHz	1447.9 MHz	1475.9 MHz	1495.9 MHz	FDD
12	698 MHz	716 MHz	728 MHz	746 MHz	FDD
13	777 MHz	787 MHz	746 MHz	756 MHz	FDD
14	788 MHz	798 MHz	758 MHz	768 MHz	FDD
15	Reserved		Reserved		-
16	Reserved		Reserved		-
17	704 MHz	716 MHz	734 MHz	746 MHz	FDD
18	815 MHz	830 MHz	860 MHz	875 MHz	FDD
19	830 MHz	845 MHz	875 MHz	890 MHz	FDD
20	832 MHz	862 MHz	791 MHz	821 MHz	FDD
21	1447.9 MHz	1462.9 MHz	1495.9 MHz	1510.9 MHz	FDD
22	3410 MHz	3500 MHz	3510 MHz	3600 MHz	FDD
...					
33	1900 MHz	1920 MHz	1900 MHz	1920 MHz	TDD
34	2010 MHz	2025 MHz	2010 MHz	2025 MHz	TDD
35	1850 MHz	1910 MHz	1850 MHz	1910 MHz	TDD
36	1930 MHz	1990 MHz	1930 MHz	1990 MHz	TDD
37	1910 MHz	1930 MHz	1910 MHz	1930 MHz	TDD
38	2570 MHz	2620 MHz	2570 MHz	2620 MHz	TDD
39	1880 MHz	1920 MHz	1880 MHz	1920 MHz	TDD
40	2300 MHz	2400 MHz	2300 MHz	2400 MHz	TDD
[41]	[3400] MHz	[3600] MHz	[3400] MHz	[3600] MHz	TDD

Note: Frequency arrangement for certain operating bands in Table 11.2.2-1 may be modified, eg. split into sub-bands, according as the future studies.

Introduction of the following other ITU-R IMT bands are not precluded in the future.

- (a) Possible frequency bands in 3.4-3.8 GHz band
- (b) Possible frequency bands in 3.4-3.6GHz as well as 3.6-4.2GHz
- (c) Possible frequency bands in 3.4-3.6 GHz band
- (d) Possible frequency bands in 450–470 MHz band,
- (e) Possible frequency bands in 698–862 MHz band
- (f) Possible frequency bands in 790–862 MHz band
- (g) Possible frequency bands in 2.3–2.4 GHz band
- (h) Possible frequency bands in 4.4-4.99 GHz band

11.3 UE RF requirements

11.3.1 General

LTE-Advanced extends LTE release 8 with support for *Carrier Aggregation*, where two or more *component carriers* (CC) are aggregated in order to support wider transmission bandwidths up to 100MHz and for spectrum aggregation. A terminal may simultaneously receive one or multiple component carriers depending on its capabilities

It will be possible to aggregate a different number of component carriers of possibly different bandwidths in the UL and the DL. In typical TDD deployments, the number of component carriers and the bandwidth of each component carrier in UL and DL will be the same. Both Intra and Inter band carrier aggregation are considered as potential Tx RF scenarios and parameters and cover both of; Contiguous Component Carrier and non-contiguous Component Carrier aggregation

RAN4, RF requirements are specified in terms of a Minimum Requirements

11.3.2 Transmitter characteristics

RAN4 Tx characteristic would need to support 3 generic aggregation scenarios depending on UE capability;

- Intra band contiguous component carrier (CC) aggregation
- Intra band non - contiguous component carrier (CC) aggregation
- Inter band non-contiguous component carrier (CC) aggregation

11.3.2.1 Transmitter architecture

Figure 11.3.2.1-1 illustrates various TX architectures options according to where the component carriers are combined, i.e., at digital baseband, or in analog waveforms before RF mixer, or after mixer but before the PA, or after the PA.

Option A

- In an adjacent *contiguous common carrier* aggregation scenario, the UE very likely has one PA. Connected to the PA can be a single RF chain (a zero-IF mixer, a wideband DAC, and a wideband IFFT)

Option-B

- Combines analog baseband waveforms from component Carrier first (e.g., via a mixer operating at an IF of roughly the bandwidth of the other component carrier in the example of 2-component carrier aggregation). Then the resulting wideband signal is up-converted to RF.

Option-C

- Does ZIF up-conversion of each component carrier before combining and feeding into a single PA.

Option-D

- Employs multiple RF chains and multiple PAs after which the high-power signals are combined and fed into a single antenna. PA coupling at the UE can be challenging for option-D.

Tx Characteristics				
Option	Description (Tx architecture)	Intra Band aggregation		Inter Band aggregation
		Contiguous (CC)	Non contiguous (CC)	Non contiguous (CC)
A	 <p>Single (baseband + IFFT + DAC + mixer + PA)</p>	Yes		
B	 <p>Multiple (baseband + IFFT + DAC), single (stage-1 IF mixer + combiner @ IF + stage-2 RF mixer + PA)</p>	Yes	Yes	
C	 <p>Multiple (baseband + IFFT + DAC + mixer), low-power combiner @ RF, and single PA</p>	Yes	Yes	
D	 <p>Multiple (baseband + IFFT + DAC + mixer + PA), high-power combiner to single antenna OR dual antenna</p>	Yes	Yes	Yes + (depending on the specific EUTRA bands being aggregated),
X	OTHERS			

Figure 11.3.2.1-1: Possible UE Architectures in three aggregation scenarios

11.3.2.2 Transmit power

In order to support backward related to UE maximum output power it is expected that LTE-Advanced UE power class should be a subset of the current EUTRA and UTRA Release 8 power classes. In the case of dual Tx antenna (separate or dual PA) or CPE / Relay products the conducted transmit power may need to be augmented to support these new features.

11.3.2.3 Output power dynamics

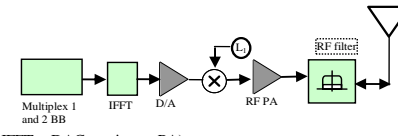
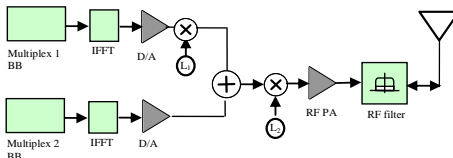
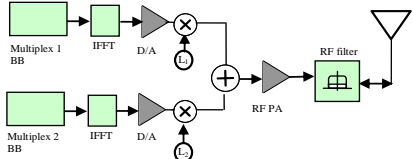
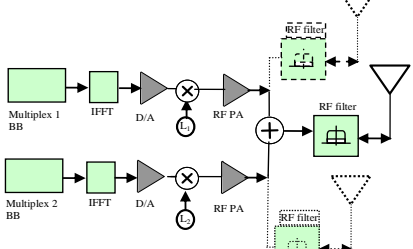
In REL-8 power control is defined on sub-frame basis for a single component carrier. For LTE-Advanced, the architecture of single or multiple PA can have an impact on the power control dynamics. In the case where the PA supports a component carrier, the CM is not a concern since each component carrier will have a fixed maximum transmit power. But a single PA architecture can potentially impact the power control procedure when its power is shared amongst component carriers

For LTE-Advanced power control would need to consider the following scenarios in the case of; OFF power, minimum power and power tolerance; In this case the transmitter characteristic for output power dynamics could be defined;

- Intra band contiguous component carrier (CC) aggregation
- Intra band non - contiguous component carrier (CC) aggregation
- Inter band non-contiguous component carrier (CC) aggregation
- Single or multiple segment power control

11.3.2.4 Transmit signal quality

In REL-8 EVM performance is defined on sub-frame basis for a single component carrier.

For LTE-Advanced EVM would need to consider the following scenarios;

- Intra band contiguous component carrier (CC) aggregation
- Intra band non - contiguous component carrier (CC) aggregation
- Inter band non-contiguous component carrier (CC) aggregation

11.3.2.5 Output RF spectrum emissions

Spurious emissions are emissions which are caused by unwanted transmitter effects such as harmonics emission, parasitic emissions, intermodulation products and frequency conversion products, but exclude out of band emissions.

In REL8 the spectrum emission mask scales in proportion to the channel bandwidth due to PA non-linearity for a single component carrier.

11.3.2.5.1 Adjacent Channel Leakage ratio

In REL-8 the ACLR is defined for each channel bandwidth. For LTE-Advanced, depending on the adjacent channel bandwidth (single or multiple CC) it may be necessary to investigate the impact of ACLR with different number of CC.

In this case the transmitter characteristic for ACLR could be defined for;

- Intra band contiguous component carrier (CC) aggregation
- Intra band non - contiguous component carrier (CC) aggregation
- Inter band non- contiguous component carrier (CC) aggregation

11.3.2.5.2 Spurious emission (UE to UE co-existence)

One aspect relating to the emission spectrum would be UE to UE co-existence.

In this case the following aspects could be defined;

- UE1 (Tx) and U2 (Rx) configuration for UE to UE co-existence analysis
- Generic limit of (-50dBm/1MHz) be applicable for the case of contiguous CC carrier
- In the case of inter band scenario exceptions may need to be defined for harmonic requirements
- Guard band for TDD non synchronized operation

11.3.2.6 Transmit intermodulation

The transmit intermodulation performance is a measure of the capability of the transmitter to inhibit the generation of signals in its non linear elements caused by presence of the wanted signal and an interfering signal reaching the transmitter via the antenna.

The current RAN1 assumption assumes in the case of contiguous CC carriers then RB can be freely allocated for the different CC carriers. In this case intermodulation performance this may need to be defined in terms; per RB allocation / per CC carrier / all CC.

11.3.3 Receiver characteristics

In order to define the consider the applicable Rx characteristic a number of working assumptions will be needed to ensure the feature is applicable in terms of UE implementation. Current REL8 working assumption has assumed some constraints due to complexity and battery saving

One new form factor that could be consider is Customer Premise Equipment (CPE) which would have the ability to initial these new features such as 2 Tx antenna port and 4 Rx antenna port as a baseline work assumption in order to address the Tx characteristics.

Rx characteristic would need to support 3 generic aggregation scenarios depending on UE capability;

- Intra band contiguous component carrier (CC) aggregation
- Intra band non - contiguous component carrier (CC) aggregation
- Inter band non-contiguous component carrier (CC) aggregation

11.3.3.1 Receiver architecture

Table 11.3.3-1 illustrates various Rx architectures options for the three scenarios

Table 11.3.3.1-1: Possible UE Architecture for the three aggregation scenarios

Rx Characteristics				
Option	Description (Rx architecture)	Intra Band aggregation		Inter Band aggregation
		Contiguous (CC)	Non contiguous (CC)	Non contiguous (CC)
A	Single (RF + FFT + baseband) with BW>20MHz	Yes		
B	Multiple (RF + FFT + baseband) with BW≤20MHz	Yes	Yes	Yes

Option A

- UE may adopt a single wideband-capable (i.e., >20MHz) RF front end (i.e., mixer, AGC, ADC) and a single FFT, or alternatively multiple "legacy" RF front ends (<=20MHz) and FFT engines. The choice between single or multiple transceivers comes down to the comparison of power consumption, cost, size, and flexibility to support other aggregation types.

Option B

- In this case, using a single wideband-capable RF front end is undesirable in the case of Intra band non contiguous CC due to the unknown nature of the signal on the "unusable" portion of the band. In the case non adjacent Inter band separate RF front end are necessary.

11.3.3.2 Receiver Sensitivity

The current reference sensitivity power level REFSSENS is the minimum mean power applied to both the UE antenna ports at which the throughput shall meet or exceed the requirements for the specified reference measurement channel

11.3.3.3 Selectivity

ACS is the ratio of the receive filter attenuation on the assigned channel frequency to the receive filter attenuation on the adjacent channel(s).

For LTE-Advanced

- Based on single and/or multiple CC channel bandwidths
- Need to define power allocation and distribution for RB single and/or multiple CC Channel bandwidths due to UE Rx operating point (AGC)

11.3.3.4 Blocking performance

The blocking characteristic is a measure of the receiver's ability to receive a wanted signal at its assigned channel frequency in the presence of an unwanted interferer on frequencies other than those of the spurious response or the adjacent channels, without this unwanted input signal causing a degradation of the performance of the receiver beyond a specified limit.

- In-band blocking
- Out of -band blocking
- Narrow band blocking

For LTE-Advanced

- Based on single and/or multiple CC channel bandwidths
- Power allocation for RB single and/or multiple CC channel bandwidths
- Per Rx antenna ports or across all antenna ports
- Need to define power allocation and distribution for RB single and/or multiple CC Channel bandwidths due to UE Rx operating point (AGC)

11.3.3.5 Spurious response

Spurious response is a measure of the receiver's ability to receive a wanted signal on its assigned channel frequency without exceeding a given degradation due to the presence of an unwanted CW interfering signal at any other frequency at which a response is obtained i.e. for which the out of band blocking limit is not met.

5.3.3.6 Intermodulation performance

Intermodulation response rejection is a measure of the capability of the receiver to receive a wanted signal on its assigned channel frequency in the presence of two or more interfering signals which have a specific frequency relationship to the wanted signal.

For LTE-Advanced

- Based on single and/or multiple CC channel bandwidths
- Power allocation for RB single and/or multiple CC channel bandwidths
- Per Rx antenna ports or across all antenna ports

11.3.3.7 Spurious emission

The spurious emissions power is the power of emissions generated or amplified in a receiver that appear at the UE antenna connector.

11.4 BS RF requirements

11.4.1 General

LTE-Advanced BS RF requirements extend those of LTE Rel-8 considering the following component carrier aggregation scenarios:

- Intra band
 - Contiguous Component Carrier aggregation
 - Non contiguous Component Carrier aggregation

- Inter band
- Non contiguous Component Carrier aggregation

Additional RF requirements to support further features of LTE-Advanced (e.g. uplink single-user spatial multiplexing) are also considered.

LTE-Advanced RF requirements are considered for Base Stations intended for general-purpose applications based on Wide Area scenarios. Introduction of other base station classes for LTE-Advanced is not precluded. The requirements for these may be different than for general-purpose applications.

Additionally, RF requirements for Relay Node (RN) are considered.

Some of the LTE-Advanced RF requirements may only apply in certain regions either as optional requirements or set by local and regional regulation as mandatory requirements. It is normally not stated in the 3GPP specifications under what exact circumstances that the requirements apply, since this is defined by local or regional regulation.

11.4.2 Transmitter characteristics

11.4.2.1 Base Station output power

In LTE Rel-8 the base station maximum output power is defined as the mean power level per carrier measured at the antenna connector during the transmitter ON period in a specified reference condition. This can be extended in LTE-Advanced for a component carrier. The output power of multiple component carriers can be aggregated.

Base Stations intended for general-purpose applications do not have limits on the maximum output power. However, there may exist regional regulatory requirements which limit the maximum output power.

11.4.2.2 Transmitted signal quality

In LTE Rel-8 requirements for transmitted signal quality are defined for:

- Frequency error; a measure of the difference between the actual BS transmit frequency and the assigned frequency of a carrier. The same source is used for RF frequency and data clock generation.
- Error Vector Magnitude; a measure of the difference between the ideal symbols and the measured symbols after the equalization.
- In case of Tx Diversity and spatial multiplexing, the time alignment between transmitter branches, i.e. the delay between the signals from two antennas at the antenna ports

These requirements can be extended in LTE-Advanced on the basis of component carriers. Additionally, in LTE-Advanced the time alignment between component carriers is considered.

11.4.2.3 Unwanted emissions

In LTE Rel-8 requirements for unwanted emissions are defined in form of operating band unwanted emission limits. These operating band unwanted emission limits are defined from 10 MHz below the lowest frequency of the downlink operating band up to 10 MHz above the highest frequency of the downlink operating band. They apply below the lower edge of the carrier transmitted at the lowest carrier frequency and above the higher edge of the carrier transmitted at the highest carrier frequency. The unwanted emission limits in the part of the downlink operating band that falls in the spurious domain are consistent with ITU-R Recommendation SM.329.

The concept of operating band unwanted emission limits is also considered in LTE-Advanced on the basis of component carriers. Extensions to cater for the case of Non contiguous Component Carrier aggregation are considered. Furthermore, in case of inter-band aggregation, operating band unwanted emission limits shall be set in each of the active bands.

11.4.2.4 Transmitter spurious emissions

The spurious domain covers frequencies, which are separated from the carrier centre frequency by more than 250% of the necessary bandwidth, as recommended in ITU-R SM.329. These transmitter spurious emission limits apply from 9 kHz to 12.75 GHz.

The transmitter spurious emission limits of LTE-Advanced shall comply with ITU-R SM.329.

11.4.3 Receiver characteristics

11.4.3.1 Reference sensitivity level

In LTE Rel-8, the reference sensitivity power level P_{REFSENS} is the minimum mean power of a carrier received at the antenna connector at which a throughput requirement shall be met for a specified reference measurement channel.

For LTE-Advanced extensions of the LTE Rel-8 reference sensitivity are considered on the basis of component carriers and reflecting carrier aggregation scenarios.

11.4.3.2 Adjacent Channel Selectivity (ACS), narrow-band blocking, Blocking, Receiver intermodulation

In LTE Rel-8 the following receiver RF requirements are defined:

- Adjacent channel selectivity (ACS); a measure of the receiver ability to receive a wanted signal at its assigned channel frequency in the presence of an adjacent channel signal with a specified centre frequency offset.
- Blocking characteristics; a measure of the receiver ability to receive a wanted signal at its assigned channel in the presence of an unwanted interferer (specified for in-band blocking and out-of-band blocking)
- Intermodulation response rejection; a measure of the capability of the receiver to receive a wanted signal on its assigned channel frequency in the presence of two interfering signals which have a specific frequency relationship to the wanted signal.

Extensions of these receiver RF requirements are also considered in LTE-Advanced on the basis of component carriers. Suitable extensions regarding the centre frequency offset of the interfering signal(s) to cater for the case of contiguous as well as non-contiguous Component Carrier aggregation are considered. Furthermore, in case of inter-band aggregation, appropriate requirements shall be set in each of the active bands.

11.4.3.3 Performance requirements

In LTE Rel-8, demodulation performance requirements for the BS are specified for defined fixed reference channels and propagation conditions. These shall be extended for the component carriers of LTE-Advanced considering support of carrier aggregation.

12 Mobility enhancements

As LTE Rel-8, LTE-Advanced supports mobility across the cellular network and is optimized for low mobile speed from 0 to 15 km/h. Higher mobile speed between 15 and 120 km/h are also supported with high performance. Mobility across the cellular network can be maintained at speeds from 120 km/h to 350 km/h (or even up to 500 km/h depending on the frequency band). The impact of intra LTE-Advanced handovers on quality (e.g. interruption time) is less than or equal to that provided by handovers in LTE. LTE-Advanced also support techniques and mechanisms to optimize delay and packet loss during intra system handover:

- The subframe size of 1 ms makes LTE-Advanced capable of adapting to fast changing radio link conditions and allows exploitation of multiuser diversity;
- The use of scheduled and diversity resource allocation in the frequency domain allows optimisation for various speeds, i.e., the diversity resource allocation increases frequency diversity gain at high speeds, whereas the scheduled resource allocation increases multiuser diversity gain at low speeds;

- Forwarding of the data buffered in the source eNB to the target eNB prevents packet loss at handovers;
- The measurements for intra-frequency neighbour cells are performed without gaps, hence without wasting radio resources. The relevant measurements for neighbour cells that operate on a different carrier frequency from the currently served frequency, are performed during transmission/reception gaps provided by DTX/DRX, or by the packet scheduler.

13 TS 36.133 [17] requirements enhancements

As already in LTE Rel-8 and also in LTE-Advanced robust general minimum RRM requirements ensure good mobility performance across the cellular network for various mobile speeds and different network deployments. The minimum RRM requirements are defined both in idle mode and in active mode. In Active mode the requirements are defined both without DRX and with DRX in order to ensure that good mobility performance in all cases while still minimising UE battery consumption especially with long DRX cycles. Different network controlled parameter values for cell reselection in idle mode and for handover in active mode can be utilised for optimising mobility performance in different scenarios, which also include low mobility and high mobility scenarios.

14 MBMS Enhancements

The MBMS baseline in LTE-Advanced is the one being introduced in LTE Rel-9 where MBMS can be provided in with single frequency network mode of operation (MBSFN). This multi-cell transmission is characterized by synchronous transmission by eNBs and their combining at the UE. The content synchronization across eNBs is guaranteed through synchronised radio frame timing, common configuration of the radio protocol stack and usage of a SYNC protocol in the CN. Multi-cell transmission doubles spectral efficiency in downlink compared to single-cell one.

15 SON Enhancements

To ease network performance analyses and minimize operational effort, LTE-Advanced extends LTE with the support of the following self optimization features:

- Coverage and capacity optimisation: aims at providing continuous coverage and optimal capacity of the network, by measurements derived in the network. Call drop rates give a first indication for areas with insufficient coverage, traffic counters identify capacity problems. Since coverage and capacity are linked, ability to balance the trade-off between the two of them should be possible;
- Mobility robustness optimization: mobility parameters optimisation to reduce the number of HO-related radio link failures. As Incorrect HO parameter settings, even if it does not result in radio link failure, may lead to serious degradation of the service performance, the avoidance of ping-pong effect or prolonged connection to non-optimal cell is a secondary objective of Mobility robustness optimization;
- Mobility load balancing: optimisation of cell reselection/handover parameters in order to cope with the unequal traffic load and to minimize the number of handovers and redirections needed to achieve the load balancing;
- RACH Optimization: an automatic RACH optimization function monitors the prevailing conditions, e.g., a change on RACH load, uplink interference, and determines and updates the appropriate parameters in order to minimize access delays for all UEs in the system and RACH load.

In addition to SON, the Minimisation of Drive Tests functionality creates an enhanced and combined effort to optimize the performance of the network. The function aims to automate the collection of UE measurements and thus minimize the need for operators to rely on manual drive-tests. The feedback from UE experiencing problems (i.e. lack of coverage, traffic is unevenly distributed or the user throughput is low) gives a beneficial overview about the network. Thus logging and reporting various UE measurement data provides foundation for network optimization. Furthermore the collected field measurements may be used for a wide scope of SON use cases.

16 Self-Evaluation Report on "LTE Release 10 and beyond (LTE-Advanced)"

The evaluation results provided here are in support of the submission of the 3GPP "LTE Release 10 & beyond (LTE-Advanced)" to the ITU-R as a candidate technology for the IMT-Advanced. This information supports the completion of the compliance templates described in section 4.2.4. of Report ITU-R M.2133 [7].

The 3GPP submission to the ITU-R includes the following templates organized as an FDD Radio Interface Technology component (FDD RIT) and as a TDD Radio Interface Technology component (TDD RIT). Together the FDD RIT and the TDD RIT comprise a Set of Radio Interface Technologies (SRIT).

The 3GPP developed FDD RIT and TDD RIT templates include characteristics and link budget templates and compliance templates for services, spectrum, and technical performance. These templates are found in Annex C.

The capabilities addressed here span the capabilities from LTE Rel-8 and extend through Rel-10 and beyond. As such the capabilities represent a range of possible functionalities and solutions that might be adopted by 3GPP in the work on the further specifications of LTE.

The ITU-R documents in the references [7-10], the work of 3GPP and individual companies was utilized in the preparation of this self-evaluation report.

16.1 Peak spectral efficiency

Tables 16.1-1 and 16.1-2 show the downlink peak spectral efficiency for FDD and TDD, respectively. The spectral efficiency is derived based on the following assumptions: 20 MHz bandwidth, one symbol L1/L2 control, cell-specific reference signals corresponding to one and four cell-specific antenna ports, UE-specific reference signals corresponding to 24 and zero resource elements per resource-block pair, and PBCH/SS occupying a total of 564 and 528 resource elements per radio frame for DL 8 and 4-layer spatial multiplexing, respectively. In addition, UL/DL configuration 1 (2DL:1SP:2UL) and special-subframe configuration 4 (12DwPTS:1GP:1UpPTS, UpPTS for SRS transmission) are assumed in case of TDD.

The tables show that already LTE Rel-8 fulfills the ITU requirements in terms of downlink peak spectral efficiency. *Thus it can be concluded that any of the evaluated LTE configurations fulfill the ITU requirements on downlink peak spectral efficiency.* The table also illustrates the further improved performance that can be achieved by using additional technology features (downlink 8-layer spatial multiplexing).

Table 16.1-1: DL peak spectrum efficiency for FDD

Scheme	Spectral efficiency [b/s/Hz]
ITU Requirement	15
Rel-8 4-layer spatial multiplexing	16.3
8-layer spatial multiplexing	30.6

Table 16.1-2: DL peak spectrum efficiency for TDD

Scheme	Spectral efficiency [b/s/Hz]
ITU Requirement	15
Rel-8 4-layer spatial multiplexing	16.0
8-layer spatial multiplexing	30.0

Tables 16.1-3 and 4 show the uplink peak spectral efficiency for FDD and TDD respectively. The spectral efficiency is derived based on the following assumptions: 20 MHz bandwidth, PUCCH of 2 resource block pairs per subframe and PRACH of 6 resource block pairs per radio frame. The same UL/DL and special-subframe configurations are assumed as for the downlink peak-spectral efficiency calculation, see above.

The tables show that the extension of LTE Rel-8 with 2-layer spatial multiplexing fulfills the ITU requirements in UL. Thus it can be concluded that any of the evaluated LTE configurations fulfill the ITU requirements on uplink peak spectral efficiency. The tables also illustrate the further improved performance that can be achieved by using additional technology features (uplink 4-layer spatial multiplexing).

Table 16.1-3: UL peak spectral efficiency for FDD

Scheme	Spectral efficiency [b/s/Hz]
ITU Requirement	6.75
2 layer spatial multiplexing	8.4
4 layer spatial multiplexing	16.8

Table 16.1-4: UL peak spectral efficiency for TDD

Scheme	Spectral efficiency [b/s/Hz]
ITU Requirement	6.75
2 layer spatial multiplexing	8.1
4 layer spatial multiplexing	16.1

16.2 C-plane latency

16.2.1 Idle to Connected

The different steps involved in the transition from Idle to Connected mode in LTE-Advanced are depicted on Figure 16.2.1-1 below:

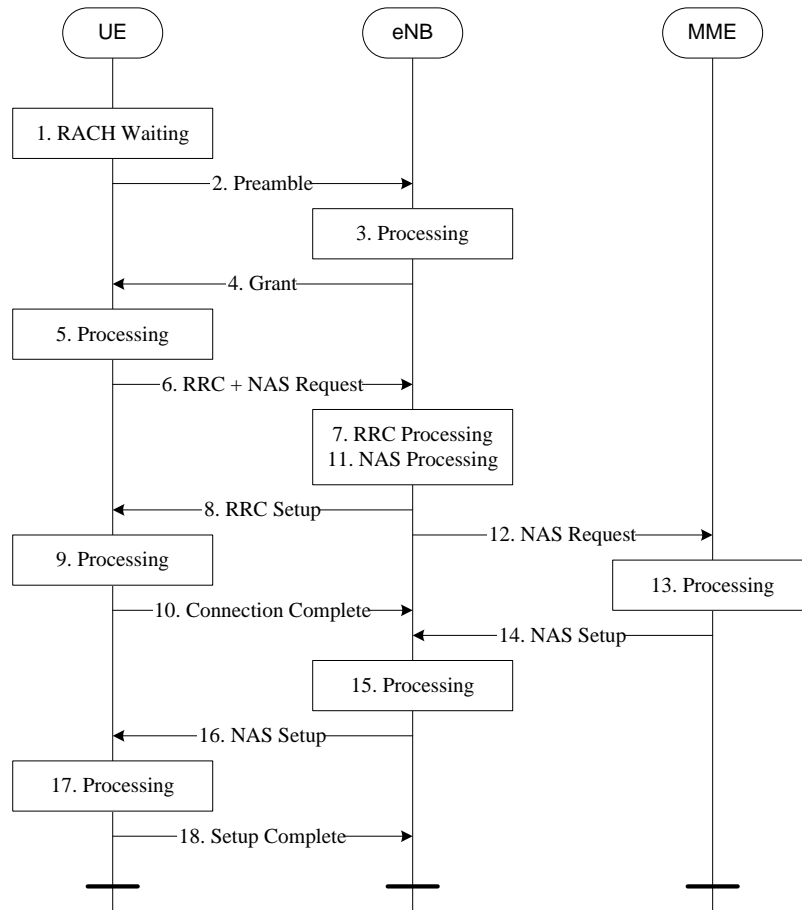

Figure 16.2.1-1: From Idle to Connected mode

Taking LTE Release 8 as a baseline (see Annex B) and including the improvements described in subclause 10.1, the transition time from Idle to Connected mode can be reduced to 50ms as summarized in Table 16.2.1-1 below. Note that since the NAS setup portion is executed in parallel to the RRC one thanks to the combined request, it does not appear in the total (assuming that that the total delay of steps 11-14 is shorter than or equal to the total delay of steps 7-10...). Thus it can be concluded that any of the evaluated LTE configurations fulfill the ITU requirements on C-plane latency for Idle to Connected transition.

Table 16.2.1-1: Transition time from Idle to Connected mode

Component	Description	Time (ms)
1	Average delay due to RACH scheduling period (1ms RACH cycle)	0.5
2	RACH Preamble	1
3-4	Preamble detection and transmission of RA response (Time between the end RACH transmission and UE's reception of scheduling grant and timing adjustment)	3
5	UE Processing Delay (decoding of scheduling grant, timing alignment and C-RNTI assignment + L1 encoding of RRC Connection Request)	5
6	Transmission of RRC and NAS Request	1
7	Processing delay in eNB (L2 and RRC)	4
8	Transmission of RRC Connection Set-up (and UL grant)	1
9	Processing delay in the UE (L2 and RRC)	12
10	Transmission of RRC Connection Set-up complete	1
11	<i>Processing delay in eNB (Uu → S1-C)</i>	
12	<i>S1-C Transfer delay</i>	
13	<i>MME Processing Delay (including UE context retrieval of 10ms)</i>	
14	<i>S1-C Transfer delay</i>	
15	Processing delay in eNB (S1-C → Uu)	4
16	Transmission of RRC Security Mode Command and Connection Reconfiguration (+TTI alignment)	1.5
17	Processing delay in UE (L2 and RRC)	16
	Total delay	50

16.2.2 Dormant to Active

As an example, the different steps involved in the transition from a Dormant to an Active state when the UE is already synchronised are depicted on Figure 16.2.2-1 below:

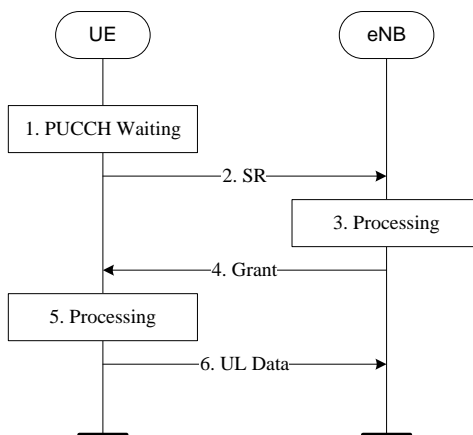

Figure 16.2.2-1: Dormant to Active transition for synchronised UE

Taking LTE Release 8 as a baseline (see Annex B) and including the PUCCH periodicity improvement described in subclause 10.2, the transition time from a Dormant to an Active state when the UE is already synchronised can be reduced to 9.5 ms as summarized in Table 16.2.2-1 below. Thus it can be concluded that any of the evaluated LTE configurations fulfill the ITU requirements on C-plane latency for Idle to Connected transition.

Table 16.2.2-1: Dormant to Active transition for synchronized UE

Component	Description	Time [ms]
1	Average delay to next SR opportunity (1ms PUCCH cycle)	0.5
2	UE sends Scheduling Request	1
3	eNB decodes Scheduling Request and generates the Scheduling Grant	3
4	Transmission of Scheduling Grant	1
5	UE Processing Delay (decoding of scheduling grant + L1 encoding of UL data)	3
6	Transmission of UL data	1
	Total delay	9.5

16.3 U-Plane latency

As highlighted in subclause 10.2, LTE Rel-8 already benefits from a U-Plane latency below 10ms (see Annex B) for synchronised UEs. In situations where the UE does not have a valid scheduling assignment, or when the UE needs to synchronize and obtain a scheduling assignment, a reduced RACH scheduling period, shorter PUCCH cycle and reduced processing delays as described in subclause 10.1 could be used. *Thus it can be concluded that any of the evaluated LTE configurations fulfill the ITU requirements on U-plane latency for Idle to Connected transition.*

16.4 Spectral efficiency and user throughput

Cell spectral efficiency and cell-edge spectral efficiency are evaluated through extensive simulations conducted by a number of companies. The simulation assumptions applied in the following evaluations are shown in Annex A. Detailed information covering a range of possible configurations is provided in Annex A.3 and [13]. In the tables below a subset of the configurations is provided from the data in [13]. This provides a representative selection of current and possible capabilities in various configurations that could be deployed.

For downlink, cell spectral efficiency and cell-edge spectral efficiency are evaluated by assuming overhead corresponding to downlink control channels that spans L OFDM symbols with $L = 1$, $L = 2$ and $L = 3$. Each value in the table is obtained as an average of all the samples obtained by different companies. The number of samples is also shown in each table.

All the results below show that the requirement is fulfilled with $L = 3$, corresponding to the largest overhead except the system bandwidth 1.4 MHz. Relaxing the overhead assumption to $L = 1$ and 2 further enhances the throughput performance.

16.4.1 Cell spectral efficiency and cell-edge spectral efficiency

16.4.1.1 Indoor

Tables 16.4.1.1-1 and 16.4.1.1-2 show the downlink spectral-efficiency results in the indoor environment (InH (Indoor Hotspot) channel model) for FDD and TDD, respectively. The tables show that already LTE Rel-8 with SU-MIMO 4 x 2 fulfills the ITU requirements. *Thus it can be concluded that any of the evaluated LTE configurations fulfill the ITU requirements on downlink cell-average and cell-edge spectral efficiency for the indoor environment.* The tables also illustrate the further improved performance that can be achieved by using additional technology features.

Table 16.4.1.1-1: Downlink spectral efficiency in indoor (FDD), InH

Scheme and antenna configuration	ITU Requirement (Ave./Edge)	Number of samples	Cell average [b/s/Hz/cell]			Cell edge [b/s/Hz]		
			L=1	L=2	L=3	L=1	L=2	L=3
Rel-8 SU-MIMO 4 x 2 (A)	3 / 0.1	15	4.8	4.5	4.1	0.23	0.21	0.19
MU-MIMO 4 x 2 (C)	3 / 0.1	3	6.6	6.1	5.5	0.26	0.24	0.22

Table 16.4.1.1-2: Downlink spectral efficiency (TDD), InH

Scheme and antenna configuration	ITU Requirement (Ave./Edge)	Number of samples	Cell average [b/s/Hz/cell]			Cell edge [b/s/Hz]		
			L=1	L=2	L=3	L=1	L=2	L=3
Rel-8 SU-MIMO 4 x 2 (A)	3 / 0.1	10	4.7	4.4	4.1	0.22	0.20	0.19
MU-MIMO 4 x 2 (C)	3 / 0.1	4	6.7	6.1	5.6	0.24	0.22	0.20

Tables 16.4.1.1-3 and 16.4.1.1-4 show the uplink spectral efficiency results in the indoor environment (InH channel model) for FDD and TDD, respectively. The tables show that already LTE Rel-8 with SIMO 1 x 4 fulfills the ITU requirements. *Thus it can be concluded that any of the evaluated LTE configurations fulfill the ITU requirements on uplink cell-average and cell-edge spectral efficiency for the indoor environment.* The tables also illustrate the further improved performance that can be achieved by using additional technology features.

Table 16.4.1.1-3: Uplink spectral efficiency (FDD), InH

Scheme and antenna configuration	ITU Requirement (Ave./Edge)	Number of samples	Cell average [b/s/Hz/cell]	Cell edge [b/s/Hz]
Rel-8 SIMO 1 x 4 (A)	2.25 / 0.07	13	3.3	0.23
Rel-8 SIMO 1 x 4 (C)	2.25 / 0.07	10	3.3	0.24
Rel-8 MU-MIMO 1 x 4 (A)	2.25 / 0.07	2	5.8	0.42
SU-MIMO 2 x 4 (A)	2.25 / 0.07	5	4.3	0.25

Table 16.4.1.1-4: Uplink spectral efficiency (TDD), InH

Scheme and antenna configuration	ITU Requirement (Ave./Edge)	Number of samples	Cell average [b/s/Hz/cell]	Cell edge [b/s/Hz]
Rel-8 SIMO 1 x 4 (A)	2.25 / 0.07	9	3.1	0.22
Rel-8 SIMO 1 x 4 (C)	2.25 / 0.07	7	3.1	0.23
Rel-8 MU-MIMO 1 x 4 (A)	2.25 / 0.07	2	5.5	0.39
SU-MIMO 2 x 4 (A)	2.25 / 0.07	2	3.9	0.25

16.4.1.2 Microcellular

Tables 16.4.1.2-1 and 16.4.1.2-2 show the downlink spectral efficiency results in the microcellular environment (UMi (Urban Micro) channel model) for FDD and TDD, respectively. The tables show that, with the extension of LTE Rel-8 with MU-MIMO 4 x 2, the ITU requirements are fulfilled. *Thus it can be concluded that any of the evaluated LTE configurations fulfill the ITU requirements on downlink cell-average and cell-edge spectral efficiency for the microcellular environment.* The tables also illustrate the further improved performance that can be achieved by using additional technology features.

Table 16.4.1.2-1: Downlink spectral efficiency (FDD), Umi

Scheme and antenna configuration	ITU Requirement (Ave./Edge)	Number of samples	Cell average [b/s/Hz/cell]			Cell edge [b/s/Hz]		
			L=1	L=2	L=3	L=1	L=2	L=3
MU-MIMO 4 x 2 (C)	2.6 / 0.075	8	3.5	3.2	2.9	0.10	0.096	0.087
MU-MIMO 4 x 2 (A)	2.6 / 0.075	3	3.4	3.1	2.8	0.12	0.11	0.099
CS/CB-CoMP 4 x 2 (C)	2.6 / 0.075	5	3.6	3.3	3.0	0.11	0.099	0.089
JP-CoMP 4 x 2 (C)	2.6 / 0.075	1	4.5	4.1	3.7	0.14	0.13	0.12
MU-MIMO 8 x 2 (C/E)	2.6 / 0.075	4	4.2	3.8	3.5	0.15	0.14	0.13

Table 16.4.1.2-2: Downlink spectral efficiency (TDD), Umi

Scheme and antenna configuration	ITU Requirement (Ave./Edge)	Number of samples	Cell average [b/s/Hz/cell]			Cell edge [b/s/Hz]		
			L=1	L=2	L=3	L=1	L=2	L=3
MU-MIMO 4 x 2 (C)	2.6 / 0.075	8	3.5	3.2	3.0	0.11	0.096	0.089
MU-MIMO 4 x 2 (A)	2.6 / 0.075	1	3.2	2.9	2.7	0.11	0.10	0.095
CS/CB-CoMP 4 x 2 (C)	2.6 / 0.075	3	3.6	3.3	3.1	0.10	0.092	0.086
JP-CoMP 4 x 2 (C)	2.6 / 0.075	1	4.6	4.2	3.9	0.10	0.092	0.085
MU-MIMO 8 x 2 (C/E)	2.6 / 0.075	4	4.2	3.9	3.6	0.12	0.11	0.099

Tables 16.4.1.2-3 and 16.4.1.2-4 show the uplink spectral efficiency results in the microcellular environment (UMi channel model) for FDD and TDD, respectively. The tables show that already LTE Rel-8 with SIMO 1 x 4 fulfills the ITU requirements. *Thus it can be concluded that any of the evaluated LTE configurations fulfill the ITU requirements on uplink cell-average and cell-edge spectral efficiency for the microcellular environment.* The tables also illustrate the further improved performance that can be achieved by using additional technology features.

Table 16.4.1.2-3: Uplink spectral efficiency (FDD), Umi

Scheme and antenna configuration	ITU Requirement (Ave./Edge)	Number of samples	Cell average [b/s/Hz/cell]	Cell edge [b/s/Hz]
Rel-8 SIMO 1 x 4 (C)	1.8 / 0.05	12	1.9	0.073
Rel-8 MU-MIMO 1 x 4 (A)	1.8 / 0.05	2	2.5	0.077
MU-MIMO 2 x 4 (A)	1.8 / 0.05	1	2.5	0.086

Table 16.4.1.2-4: Uplink spectral efficiency (TDD), Umi

Scheme and antenna configuration	ITU Requirement (Ave./Edge)	Number of samples	Cell average [b/s/Hz/cell]	Cell edge [b/s/Hz]
Rel-8 SIMO 1 x 4 (C)	1.8 / 0.05	9	1.9	0.070
Rel-8 MU-MIMO 1 x 4 (A)	1.8 / 0.05	2	2.3	0.071
MU-MIMO 2 x 4 (A)	1.8 / 0.05	1	2.8	0.068
MU-MIMO 1 x 8 (E)	1.8 / 0.05	1	3.0	0.079

16.4.1.3 Base coverage urban

Tables 16.4.1.3-1 and 16.4.1.3-2 show the downlink spectral efficiency results of the base coverage urban environment (UMa (Urban Macro) channel model) for FDD and TDD, respectively. The tables show that, with the extension of LTE Rel-8 with the MU-MIMO 4 x 2 or CS/BF MU-MIMO 4 x 2, the ITU requirements are fulfilled. *Thus it can be concluded that any of the evaluated LTE configurations fulfill the ITU requirements on downlink cell-average and cell-edge spectral efficiency for the base coverage urban environment.* The tables also illustrate the further improved performance that can be achieved by using additional technology features.

Table 16.4.1.3-1: Downlink spectral efficiency (FDD), Uma

Scheme and antenna configuration	ITU Requirement (Ave./Edge)	Number of samples	Cell average [b/s/Hz/cell]			Cell edge [b/s/Hz]		
			L=1	L=2	L=3	L=1	L=2	L=3
MU-MIMO 4 x 2 (C)	2.2 / 0.06	7	2.8	2.6	2.4	0.079	0.073	0.066
CS/CB-CoMP 4 x 2 (C)	2.2 / 0.06	6	2.9	2.6	2.4	0.081	0.074	0.067
JP-CoMP 4 x 2 (A)	2.2 / 0.06	1	3.0	2.7	2.5	0.080	0.073	0.066
CS/CB-CoMP 8 x 2 (C)	2.2 / 0.06	3	3.8	3.5	3.2	0.10	0.093	0.084

Table 16.4.1.3-2: Downlink spectral efficiency (TDD), Uma

Scheme and antenna configuration	ITU Requirement (Ave./Edge)	Number of samples	Cell average [b/s/Hz/cell]			Cell edge [b/s/Hz]		
			L=1	L=2	L=3	L=1	L=2	L=3
MU-MIMO 4 x 2 (C)	2.2 / 0.06	7	2.9	2.6	2.4	0.079	0.071	0.067
CS/CB-CoMP 4 x 2 (C)	2.2 / 0.06	4	2.9	2.6	2.4	0.083	0.075	0.070
JP-CoMP 4 x 2 (C)	2.2 / 0.06	1	3.6	3.3	3.1	0.090	0.082	0.076
CS/CB-CoMP 8 x 2 (C/E)	2.2 / 0.06	3	3.7	3.3	3.1	0.10	0.093	0.087

Tables 16.4.1.3-3 and 16.4.1.3-4 show the uplink spectral efficiency results in the base coverage urban environment (UMa channel model) for FDD and TDD, respectively. The tables show that already LTE Rel-8 with SIMO 1 x 4 fulfills the ITU requirements. *Thus it can be concluded that any of the evaluated LTE configurations fulfill the ITU requirements on uplink cell-average and cell-edge spectral efficiency for the base coverage urban environment.* The tables also illustrate the further improved performance that can be achieved by using additional technology features.

Table 16.4.1.3-3: Uplink spectral efficiency (FDD), Uma

Scheme and antenna configuration	ITU Requirement (Ave./Edge)	Number of samples	Cell average [b/s/Hz/cell]	Cell edge [b/s/Hz]
Rel-8 SIMO 1 x 4 (C)	1.4 / 0.03	12	1.5	0.062
CoMP 1 x 4 (A)	1.4 / 0.03	2	1.7	0.086
CoMP 2 x 4 (C)	1.4 / 0.03	1	2.1	0.099

Table 16.4.1.3-4: Uplink spectral efficiency (TDD), Uma

Scheme and antenna configuration	ITU Requirement (Ave./Edge)	Number of samples	Cell average [b/s/Hz/cell]	Cell edge [b/s/Hz]
Rel-8 SIMO 1 x 4 (C)	1.4 / 0.03	9	1.5	0.062
CoMP 1 x 4 (C)	1.4 / 0.03	1	1.9	0.090
CoMP 2 x 4 (C)	1.4 / 0.03	1	2.0	0.097
MU-MIMO 1 x 8 (E)	1.4 / 0.03	1	2.7	0.076

16.4.1.4 High speed

Tables 16.4.1.4-1 and 16.4.1.4-2 show the downlink spectral efficiency results in the high speed environment (RMa (Rural Macro) channel model) for FDD and TDD, respectively. The tables show that already LTE Rel-8 with SU-MIMO 4 x 2 fulfills the ITU requirements. *Thus it can be concluded that any of the evaluated LTE configurations fulfill the ITU requirements on downlink cell-average and cell-edge spectral efficiency for the high speed environment.* The tables also illustrate the further improved performance that can be achieved by using additional technology features.

Table 16.4.1.4-1: Downlink spectral efficiency (FDD), Rma

Scheme and antenna configuration	ITU Requirement (Ave./Edge)	Number of samples	Cell average [b/s/Hz/cell]			Cell edge [b/s/Hz]		
			L=1	L=2	L=3	L=1	L=2	L=3
Rel-8 SU-MIMO 4 x 2 (C)	1.1 / 0.04	15	2.3	2.1	1.9	0.081	0.076	0.069
Rel-8 SU-MIMO 4 x 2 (A)	1.1 / 0.04	14	2.1	2.0	1.8	0.067	0.063	0.057
MU-MIMO 4 x 2 (C)	1.1 / 0.04	3	3.9	3.5	3.2	0.11	0.099	0.090
MU-MIMO 8 x 2 (C)	1.1 / 0.04	1	4.1	3.7	3.4	0.13	0.12	0.11

Table 16.4.1.4-2: Downlink spectral efficiency (TDD), Rma

Scheme and antenna configuration	ITU Requirement (Ave./Edge)	Number of samples	Cell average [b/s/Hz/cell]			Cell edge [b/s/Hz]		
			L=1	L=2	L=3	L=1	L=2	L=3
Rel-8 SU-MIMO 4 x 2 (C)	1.1 / 0.04	8	2.0	1.9	1.8	0.072	0.067	0.063
Rel-8 SU-MIMO 4 x 2 (A)	1.1 / 0.04	7	1.9	1.7	1.6	0.057	0.053	0.049
MU-MIMO 4 x 2 (C)	1.1 / 0.04	4	3.5	3.2	3.0	0.098	0.089	0.083
MU-MIMO 8 x 2 (C/E)	1.1 / 0.04	2	4.0	3.6	3.4	0.12	0.11	0.10
Rel-8 single-layer BF 8 x 2 (E)	1.1 / 0.04	4	2.5	2.3	2.1	0.11	0.10	0.093

Tables 16.4.1.4-3 and 16.4.1.4-4 show the uplink spectral efficiency results in the high speed environment (RMA channel model) for FDD and TDD, respectively. The tables show that already LTE Rel-8 with SIMO 1 x 4 fulfills the ITU requirements. *Thus it can be concluded that any of the evaluated LTE configurations fulfill the ITU requirements on uplink cell-average and cell-edge spectral efficiency for the high speed environment.* The tables also illustrate the further improved performance that can be achieved by using additional technology features.

Table 16.4.1.4-3: Uplink spectral efficiency (FDD), Rma

Scheme and antenna configuration	ITU Requirement (Ave./Edge)	Number of samples	Cell average [b/s/Hz/cell]	Cell edge [b/s/Hz]
Rel-8 SIMO 1 x 4 (C)	0.7 / 0.015	11	1.8	0.082
Rel-8 MU-MIMO 1 x 4 (A)	0.7 / 0.015	2	2.2	0.097
CoMP 2 x 4 (A)	0.7 / 0.015	2	2.3	0.13

Table 16.4.1.4-4: Uplink spectral efficiency (TDD), Rma

Scheme and antenna configuration	ITU Requirement (Ave./Edge)	Number of samples	Cell average [b/s/Hz/cell]	Cell edge [b/s/Hz]
Rel-8 SIMO 1 x 4 (C)	0.7 / 0.015	8	1.8	0.080
Rel-8 MU-MIMO 1 x 4 (A)	0.7 / 0.015	2	2.1	0.093
CoMP 2 x 4 (A)	0.7 / 0.015	1	2.5	0.15
MUMIMO 1 x 8 (E)	0.7 / 0.015	1	2.6	0.10

16.4.2 Number of supported VoIP users

The number of supported VoIP users (VoIP capacity) is evaluated through extensive simulations conducted by a number of companies. The simulation assumptions applied in the following evaluations are shown in Annex A. Detailed information covering a range of possible configurations is provided in Annex A.3 and [13]. In the tables below the results are provided by LTE Rel-8.

Tables 16.4.2-1 and 16.4.2-2 show the VoIP capacity results in the Indoor, Microcellular, Base coverage urban and High speed for FDD and TDD, respectively. The tables show that already LTE Rel-8 fulfills the ITU requirements. *Thus it can be concluded that any of the evaluated LTE configurations fulfill the ITU requirements on VoIP capacity for all the environments.*

Table 16.4.2-1: VoIP capacity for FDD

Antenna configuration	Environment	ITU requirement	Number of samples	Capacity [User/MHz/Cell]
Antenna configuration (A)	Indoor	50	3	140
	Urban Micro	40	3	80
	Urban Macro	40	3	68
	High Speed	30	3	91
Antenna configuration (C)	Indoor	50	3	131
	Urban Micro	40	3	75
	Urban Macro	40	3	69
	High Speed	30	3	94

Table 16.4.2-2: VoIP capacity for TDD

Antenna configuration	Environment	ITU requirement	Number of samples	Capacity [User/MHz/Cell]
Antenna configuration (A)	Indoor	50	2	137
	Urban Micro	40	2	74
	Urban Macro	40	2	65
	High Speed	30	2	86
Antenna configuration (C)	Indoor	50	3	130
	Urban Micro	40	3	74
	Urban Macro	40	3	67
	High Speed	30	3	92

16.4.3 Mobility traffic channel link data rates

Mobility traffic channel link data rates are evaluated through extensive simulations conducted by a number of companies. The simulation assumptions applied in the following evaluations are shown in Annex A. Detailed information covering a range of possible configurations is provided in Annex A.3 and [13]. In the tables below the results are conducted by LTE Rel-8.

Tables 16.4.3-1 and 16.4.3-2 show the mobility traffic channel link data rates in the Indoor, Microcellular, Base coverage urban and High speed for FDD and TDD, respectively. The tables show that already LTE Rel-8 fulfills the ITU requirements. *Thus it can be concluded that any of the evaluated LTE configurations fulfill the ITU requirements on mobility traffic channel link data rate for all the environments.*

Table 16.4.3-1: Mobility traffic channel link data rates for FDD

LOS/NLOS	Environment	ITU requirement	Median SINR [dB]	Number of samples	FDD UL Spectrum efficiency [b/s/Hz]
Antenna configuration 1 x 4, NLOS	Indoor	1.0	13.89	7	2.56
	Urban Micro	0.75	4.54	7	1.21
	Urban Macro	0.55	4.30	7	1.08
	High Speed	0.25	5.42	7	1.22
Antenna configuration 1 x 4, LOS	Indoor	1.0	13.89	4	3.15
	Urban Micro	0.75	4.54	4	1.42
	Urban Macro	0.55	4.30	4	1.36
	High Speed	0.25	5.42	4	1.45

Table 16.4.3-2: Mobility traffic channel link data rates for TDD

LOS/NLOS	Environment	ITU requirement	Median SINR [dB]	Number of samples	TDD UL Spectrum efficiency [b/s/Hz]
Antenna configuration 1 x 4, NLOS	Indoor	1.0	13.89	4	2.63
	Urban Micro	0.75	4.54	4	1.14
	Urban Macro	0.55	4.30	4	0.95
	High Speed	0.25	5.42	4	1.03
Antenna configuration 1 x 4, LOS	Indoor	1.0	13.89	2	3.11
	Urban Micro	0.75	4.54	2	1.48
	Urban Macro	0.55	4.30	2	1.36
	High Speed	0.25	5.42	2	1.38

16.5 Handover Performance

The generic handover procedure of LTE-Advanced builds upon the one developed for LTE and is shown in Figure 16.5-1 below:

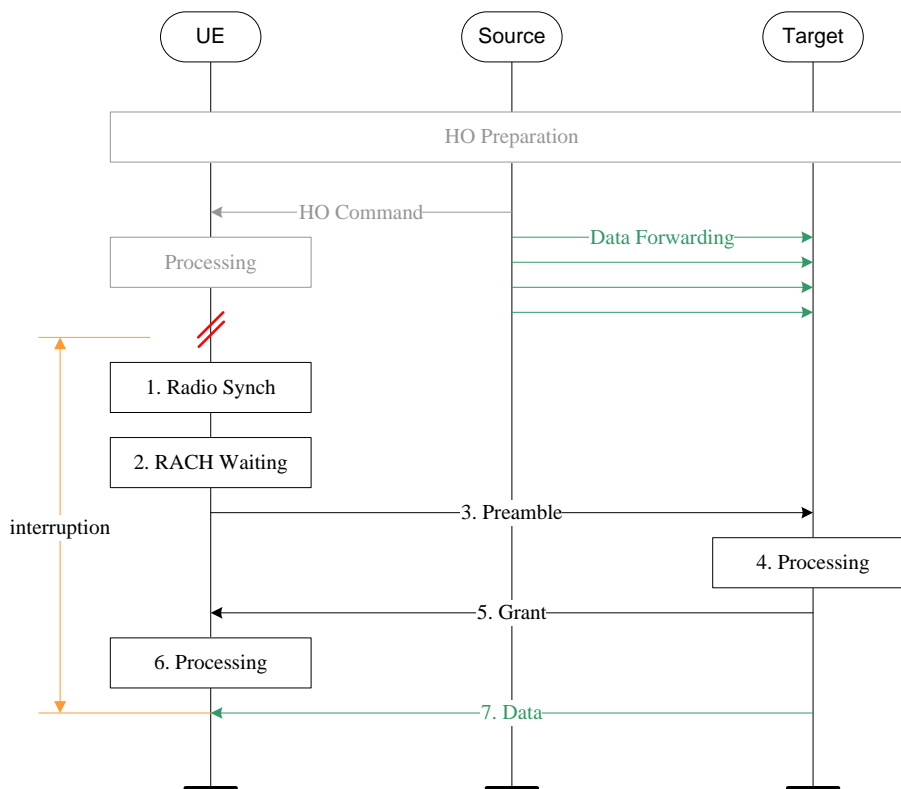

Figure 16.5-1: U-Plane interruption in LTE-Advanced

Once the HO command has been processed by the UE, it leaves the source cell and stops receiving data. This is the point in time where data interruption starts. The first step after that is the radio synchronisation, which consists of:

- 1) Frequency synchronization: typically the time taken for frequency synchronisation depends on whether the target cell is operating on the same carrier frequency as the currently served frequency or not. But since the UE has already identified and measured the target cell, this delay is negligible
- 2) DL synchronization: although baseband and RF alignments always take some time, since the UE has already acquired DL synchronisation to the target cell in conjunction with previous measurement and can relate the target cell DL timing to the source cell DL timing with an offset, the corresponding delay is less than 1 ms.

Because forwarding is initiated before the UE moves and establishes connection to the target cell and because the backhaul is faster than the radio interface, forwarded data is already awaiting transmission in the target when the UE is ready to receive. This component therefore does not affect the overall delay.

In FDD RIT, the average delay due to RACH scheduling period is **0.5ms** in the best case (**1ms RACH periodicity**). In TDD RIT, although the shortest delay is obtained with configuration 0 (offering 6 normal uplink subframes), when factoring in the average waiting time for a downlink subframe to receive the RA response and initiate the transmission of DL data, configuration 1 (with random access preambles in special subframes) offers the shortest U-Plane interruption.

In total, the interruption time is 10.5ms for FDD RIT and 12.5ms for TDD RIT as summarized in Tables 16.5-1 and 16.5-2 respectively below. Note that this delay does not depend on the frequency of the target as long as the cell has already been measured by the UE, which is a typical scenario.

Table 16.5-1: U-Plane interruption in LTE-Advanced for FDD RIT

Component	Description	Time [ms]
1	Radio Synchronisation to the target cell	1
2	Average delay due to RACH scheduling period (1ms periodicity)	0.5
3	RACH Preamble	1
4-5	Preamble detection and transmission of RA response (Time between the end RACH transmission and UE's reception of scheduling grant and timing adjustment)	5
6	Decoding of scheduling grant and timing alignment	2
7	Transmission of DL Datta	1
	Total delay	10.5

Table 16.5-2: U-Plane interruption in LTE-Advanced for TDD RIT (configuration 1 with random access preambles in special subframes)

Component	Description	Time [ms]
1	Radio Synchronisation to the target cell	1
2	Average delay due to RACH scheduling period	2.5
3	RACH Preamble	1
4-5	Preamble detection and transmission of RA response (Time between the end RACH transmission and UE's reception of scheduling grant and timing adjustment)	5
6	Decoding of scheduling grant and timing alignment	2
7	Transmission of DL Data	1
	Total delay	12.5

16.5.1 Intra-frequency handover interruption time

As explained in subclause 16.5 above, the interruption is 10.5ms for FDD RIT and 12.5ms for TDD RIT regardless of the frequency of the target cell. *Thus it can be concluded that any of the evaluated LTE configurations fulfill the ITU requirements on intra-frequency handover interruption time.*

16.5.2 Inter-frequency handover interruption time within a spectrum band

As explained in subclause 16.5 above, the interruption is 10.5ms for FDD RIT and 12.5ms for TDD RIT regardless of the frequency of the target cell. *Thus it can be concluded that any of the evaluated LTE configurations fulfill the ITU requirements on inter-frequency handover interruption time within a spectrum band.*

16.5.3 Inter-frequency handover interruption time between spectrum bands

As explained in subclause 16.5 above, the interruption is 10.5ms for FDD RIT and 12.5ms for TDD RIT regardless of the frequency of the target cell. *Thus it can be concluded that any of the evaluated LTE configurations fulfill the ITU requirements on inter-frequency handover interruption time between spectrum bands.*

16.6 Spectrum and bandwidth

16.6.1 Deployment in IMT bands

The bands in which the proposed FDD RIT component and TDD RIT component can be deployed are given in 11.2.2.

Both the FDD RIT and the TDD RIT fulfil the requirement of being able to utilize at least one band identified for IMT.

16.6.2 Bandwidth and channel bandwidth scalability

In both the FDD RIT and the TDD RIT, one component carrier supports a scalable bandwidth, 1.4, 3, 5, 10, 15 and 20 MHz (see 11.2.1.1). By aggregating multiple component carriers, wider transmission bandwidths up to 100 MHz are supported (see 5.1).

Both the FDD RIT and the TDD RIT fulfil the requirement to support a scalable bandwidth up to and including 40 MHz.

Both the FDD RIT and the TDD RIT fulfil the requirement to support of at least three band-width values.

16.7 Services

The Quality of Service (QoS) framework of LTE-Advanced builds upon the one developed for LTE and therefore allows the support of a wide range of services. In LTE-Advanced, a bearer is the level of granularity for QoS control. Each bearer can be associated with several QoS parameters, e.g.:

- QoS Class Identifier (QCI): scalar that is used as a reference to access node-specific parameters that control bearer level packet forwarding treatment (e.g. scheduling weights, admission thresholds, queue management thresholds, link layer protocol configuration, etc.), and that have been pre-configured by the operator owning the eNodeB. A one-to-one mapping of standardized QCI values to standardized characteristics is for instance captured in [4] for LTE.

Table 16.7-1: QCI Example (LTE)

QCI	Type	Packet Delay Budget	Packet Error Loss Rate	Example Services
1	GBR	80 ms	10^{-2}	Conversational Voice
2		130 ms	10^{-3}	Conversational Video (Live Streaming)
3		30 ms	10^{-3}	Real Time Gaming
4		280 ms	10^{-6}	Non-Conversational Video (Buffered Streaming)
5	Non-GBR	80 ms	10^{-6}	IMS Signalling
6		280 ms	10^{-6}	Video (Buffered Streaming) TCP-based (e.g., www, e-mail, chat, ftp, p2p file sharing, progressive video, etc.)
7		80 ms	10^{-3}	Voice, Video (Live Streaming) Interactive Gaming
8		280 ms	10^{-6}	Video (Buffered Streaming) TCP-based (e.g., www, e-mail, chat, ftp, p2p file

- Guaranteed Bit Rate (GBR): the bit rate that can be expected to be provided by a GBR bearer,

The configuration of those QoS parameters, allows LTE-Advanced to support a wide range of services. In particular, LTE-Advanced can support basic conversational service class, rich conversational service class and conversational low delay service class. In addition, LTE-Advanced is also able to support the service classes of interactive high delay, interactive low delay, streaming live, streaming non-live and background, which are also given in § 7.4.4 of Report ITU-R M.2135. Thus it can be concluded that any of the evaluated LTE configurations fulfill the ITU requirements on C-plane latency for Idle to Connected transition.

16.8 Conclusions of the Self-Evaluation

Under the IMT-Advanced process, as provided in [11], Step 6 is a decision step taking into account consideration of the evaluation results and is an assessment of the proposal as to whether it meets a version of the minimum technical requirements and evaluation criteria of the IMT-Advanced currently in force. The 3GPP self-evaluation concludes that the LTE Release 10 & beyond (LTE-Advanced) SRIT and the individual FDD RIT and TDD RIT components completely satisfy the criteria of Step 6 and should move forward to Step 7 of the process.

Under the IMT-Advanced process, as provided in [11], Step 7 is a decision step taking into account consideration of the evaluation results. In Step 7 an RIT or SRIT will be accepted for inclusion in the standardization phase described in Step 8 of the process if it is determined that the RIT or SRIT meets the requirements for at least three of the four the required test environments. The 3GPP self-evaluation concludes that the *LTE Release 10 & beyond (LTE-Advanced)* SRIT and the individual FDD RIT and TDD RIT components completely satisfy the criteria of Step 7 and should move forward to Step 8 of the process. In particular, the SRIT and the individual FDD RIT and TDD RIT components meet all the requirements in all four of the four defined test environments.

Consequently, the 3GPP *LTE Release 10 & beyond (LTE-Advanced)* technology should be included in the ITU-R IMT-Advanced terrestrial component radio interface Recommendation(s).

16A Performance Evaluation of LTE-Advanced for 3GPP target fulfillment

This chapter provide cell spectral efficiency and cell-edge spectral efficiency results of LTE-Advanced technologies evaluated through extensive simulations conducted by a number of companies. System performance requirements defined in 3GPP are shown in [3], where the target values of cell spectral efficiency and cell-edge spectral efficiency are provided for 3GPP Case 1 channel model with 2-by-2, 4-by-2, and 4-by-4 antenna configurations for downlink and 1-by-2 and 2-by-4 antenna configurations for uplink. More details of the performance evaluation assumptions and results are shown in [18].

Tables 16A-1 and 16A-2 show the downlink spectral efficiency results in the 3GPP Case1 environment for FDD and TDD, respectively. The tables show that, with the extension of LTE Rel-8 with MU-MIMO 4 x 2, the 3GPP targets are fulfilled. *Thus it can be concluded that any of the evaluated LTE configurations fulfill the 3GPP targets on downlink cell-average and cell-edge spectral efficiency for the 3GPP Case1 environment.* The tables also illustrate the further improved performance that can be achieved by using additional technology features.

Table 16A-1: Downlink spectral efficiency (FDD), Case1

Scheme and antenna configuration	3GPP Target (Ave./Edge)	Number of samples	Cell average [b/s/Hz/cell]	Cell edge [b/s/Hz]
			L=3	L=3
MU-MIMO 2 x 2 (C)	2.4 / 0.07	3	2.69	0.090
JP-CoMP 2 x 2 (C)	2.4 / 0.07	2	2.70	0.104
MU-MIMO 4 x 2 (C)	2.6 / 0.09	6	3.43	0.118
CS/CB-CoMP 4 x 2 (C)	2.6 / 0.09	4	3.34	0.129
JP-CoMP 4 x 2 (C)	2.6 / 0.09	2	3.87	0.162
MU-MIMO 4 x 4 (C)	3.7 / 0.12	5	4.69	0.203
CS/CB-CoMP 4 x 4 (C)	3.7 / 0.12	3	4.66	0.205
JP-CoMP 4 x 4 (C)	3.7 / 0.12	2	5.19	0.269

Table 16A-2: Downlink spectral efficiency (TDD), Case1

Scheme and antenna configuration	3GPP Target (Ave./Edge)	Number of samples	Cell average [b/s/Hz/cell]	Cell edge [b/s/Hz]
			L=3	L=3
MU-MIMO 2 x 2 (C)	2.4 / 0.07	2	2.88	0.113
JP-CoMP 2 x 2 (C)	2.4 / 0.07	1	3.15	0.130
MU-MIMO 4 x 2 (C)	2.6 / 0.09	6	3.76	0.151
JP-CoMP 4 x 2 (C)	2.6 / 0.09	2	4.64	0.199
MU-MIMO 4 x 4 (C)	3.7 / 0.12	3	4.97	0.209
CS/CB-CoMP 4 x 4 (C)	3.7 / 0.12	1	5.06	0.244
JP-CoMP 4 x 4 (C)	3.7 / 0.12	1	6.61	0.330

Tables 16A-3 and 16A-4 show the uplink spectral efficiency results in the 3GPP Case1 environment for FDD and TDD, respectively. The tables show that, Rel-8 SIMO, CoMP, SU-MIMO and MU-MIMO schemes fulfill the 3GPP targets. *Thus it can be concluded that any of the evaluated LTE configurations fulfill the 3GPP targets on uplink cell-average and cell-edge spectral efficiency for the 3GPP Case1 environment.* The tables also illustrate the further improved performance that can be achieved by using additional technology features.

Table 16A-3: Uplink spectral efficiency (FDD), Case1

Scheme and antenna configuration	3GPP Target (Ave./Edge)	Number of samples	Cell average [b/s/Hz/cell]	Cell edge [b/s/Hz]
Rel-8 SIMO 1 x 2 (C)	1.2 / 0.04	6	1.33	0.047
CoMP 1 x 2 (C)	1.2 / 0.04	1	1.40	0.051
SU-MIMO 2 x 4 (C)	2.0 / 0.07	6	2.27	0.091

Table 16A-4: Uplink spectral efficiency (TDD), Case1

Scheme and antenna configuration	3GPP Target (Ave./Edge)	Number of samples	Cell average [b/s/Hz/cell]	Cell edge [b/s/Hz]
Rel-8 SIMO 1 x 2 (C)	1.2 / 0.04	3	1.24	0.045
CoMP 1 x 2 (C)	1.2 / 0.04	1	1.51	0.051
SU-MIMO 2 x 4 (C)	2.0 / 0.07	3	2.15	0.090
MU-MIMO 2 x 4 (C)	2.0 / 0.07	1	2.59	0.079

17 Conclusions

During the study of LTE-Advanced, many proposals on physical and higher layer radio protocols, NW architecture, RF related issues were investigated. Proposed technical features are built based on those of the LTE Rel-8, aiming at further performance enhancement. It was shown that, with the existing and the new capabilities addressed in this document, the ITU-R requirements as well as the 3GPP requirements/targets are fulfilled. Feasibility of the new capabilities for LTE-Advanced has been proven. As a result, the LTE-Advanced study item can be closed and work items and specific study items corresponding to selected features studied under the LTE-Advanced study item can be approved.

Annex A: Simulation model

A.1 General assumption

This section describes the reference system deployments used for the different system evaluations. The table below describes the simulation assumptions.

Table A.1-1: Simulation assumption

Parameter	Values used for evaluation
Deployment scenario	<ul style="list-style-type: none"> Indoor Microcellular Base Coverage Urban High Speed Parameters and assumptions not shown here for each scenario are shown in ITU guidelines [9].
Duplex method and bandwidths	FDD: 10+10 MHz except Indoor with 20+20 MHz TDD: 20 MHz also 40 MHz in indoor Baseline asymmetry during 5 subframes period: <ul style="list-style-type: none"> - 2 full DL subframes, - Special subframe: DwPTS 11symbol, GP 1 symbol, UpPTS 2 symbol, - 2 full UL subframes Alternative special subframe configurations may be used if stated.
Network synchronization	Synchronized
Handover margin	1.0 dB
Downlink transmission scheme	Baseline transmission scheme (LTE Rel-8) <ul style="list-style-type: none"> MIMO closed loop precoded spatial multiplexing (transmission mode 4 [12]): Baseline: 4x2 MIMO MIMO single stream beamforming (transmission mode 7 [12]) Advanced scheme (LTE- Rel-10 and beyond (LTE-Advanced)) <ul style="list-style-type: none"> MU-MIMO without coordination Coordinated scheduling / Beamforming (CS/CB)-CoMP Joint processing (JP)-CoMP (SU-MIMO is possible for all cases.)
Downlink scheduler	For baseline transmission scheme (LTE Rel-8): Proportional fair in time and frequency For advanced transmission scheme (LTE- Rel-10 and beyond (LTE-Advanced)) Aligned with transmission scheme
Downlink link adaptation	Non-ideal based on non-ideal CQI/PMI/RI reports and/or non-ideal sounding transmission, reporting mode and period selected according to scheduler and MIMO transmission schemes; reporting delay and MCS based on LTE transport formats according to [12]. Baseline (LTE Rel-8): <ul style="list-style-type: none"> A) Non-frequency selective PMI and frequency selective CQI report with 5ms periodicity, subband CQI with measurement error: $N(0,1)$ per PRB B) Sounding-based precoding, frequency selective CQI report with 5ms periodicity, subband CQI with measurement error: $N(0,1)$ per PRB
Downlink HARQ scheme	Incremental redundancy or Chase combining
Downlink receiver type	Baseline scheme MMSE Advanced scheme MMSE-SIC, MLD based receiver Each company should report a description on interference rejection and cancellation capabilities.
Uplink transmission scheme	Baseline transmission scheme (LTE Rel-8) <ul style="list-style-type: none"> SIMO with and without MU-MIMO Baseline: 1 x 4 SIMO Advanced transmission scheme (LTE Rel-10 and beyond (LTE-Advanced))

	<ul style="list-style-type: none"> SU-MIMO UL CoMP
Uplink scheduler	Channel dependent
Uplink power control	Baseline: Fractional power control. Alternative: Other Rel-8 specified Power control parameters (P0 and alpha) are chosen according to the deployment scenario. (IoT reported with simulation results.)
Uplink link adaptation	Non-ideal based on delayed SRS-based measurements: MCS based on LTE transport formats and SRS period and bandwidths according to [12].
Uplink HARQ scheme	Incremental redundancy or Chase combining
Uplink receiver type	MMSE or MMSE-SIC (MU-MIMO)
Antenna configuration base station	Baseline: 4 or 8 Tx antennas with the following configurations: A) Uncorrelated co-polarized: Co-polarized antennas separated 4 wavelengths (illustration for 4 Tx:) B) Grouped co-polarized: Two groups of co-polarized antennas. 10 wavelengths between center of each group. 0.5 wavelength separation within each group (illustration for 4 Tx:) C) Correlated: co-polarized: 0.5 wavelengths between antennas (illustration for 4 Tx:) D) Uncorrelated cross-polarized: Columns with +-45deg linearly polarized antennas Columns separated 4 wavelengths (illustration for 4 Tx: X X) E) Correlated cross-polarized Columns with +-45deg linearly polarized antennas Columns separated 0.5 wavelengths (illustration for 8Tx: XXXX)
Antenna configuration UE	Baseline: Vertically polarized antennas with 0.5 wavelengths separation at UE Alternative: Columns with linearly polarized orthogonal antennas with 0.5 wavelengths spacing between columns
Channel estimation (Uplink and downlink)	Non-ideal (consider both estimation errors both for demodulation reference signals and sounding reference signals)
Control channel and reference signal overhead, Acknowledgements etc.	For baseline transmission (LTE) schemes: Downlink <ul style="list-style-type: none"> Overhead for CRS and antenna port 5 according to DL transmission schemes Overhead for DL CCH of L OFDM symbols (L=1,2,3) Overhead for SS/PBCH Uplink <ul style="list-style-type: none"> SRS overhead according to UL (and DL) scheduler and transmission scheme Overhead for UL CCH according to CQI/PMI reporting mode and periodicity used for DL simulation for the same scenario For advanced transmission schemes (LTE Rel-10 and beyond (LTE-Advanced)) Downlink <ul style="list-style-type: none"> Overhead assuming 6 MBSFN subframes per DL radio frame (FDD), 2 MBSFN subframes per DL radio frame (TDD) Overhead for DL CCH of L OFDM symbols (L=1,2,3) Overhead for SS/PBCH Overhead for CRS with 1 antenna port Overhead for DRS Uplink <ul style="list-style-type: none"> UL overhead for CSI feedback and SRS transmission according to transmission scheme factored into the uplink results for the same scenarios.
Feedback and control channel errors	None

A.2 CoMP assumption for evaluation

For the performance evaluation of DL CoMP schemes, following two types of CoMP categories were evaluated.

- Joint Processing (JP): data is available at each of the geometrically separated points, and PDSCH transmission occurs from multiple points.
- Coordinated Scheduling/Beamforming (CS/CB): data is only available at serving cell (data transmission from that point) but user scheduling/beamforming decisions are made with coordination among cells.

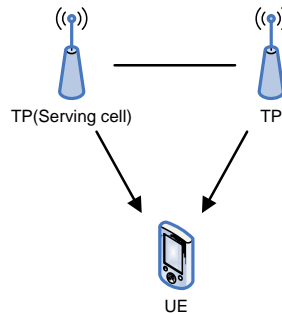

(a) Joint processing

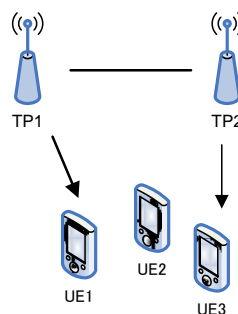

(b) Coordinated Scheduling/Beamforming (CS/CB)

Figure A.2-1: Coordinated multi-point transmission

A.3 Detailed simulation results

Detailed simulation results of cell spectral efficiency and cell edge spectral efficiency for full-buffer traffic, VoIP capacity and mobility in Section 16.4 are contained in RP-090744 [13]. The following 18 corporate entities (listed below alphabetically) participated in these simulations:

Alcatel-Lucent/Alcatel-Lucent Shanghai Bell, CATT, CMCC, Ericsson/ST-Ericsson, Fujitsu, Hitachi, Huawei, LGE, Motorola, NEC, Nokia/Nokia Siemens Networks, NTT DOCOMO, Panasonic, Qualcomm, RITT, Samsung, Texas Instruments, ZTE

Annex B: Latency performance of Rel-8

B.1 C-plane latency

B.1.1 Transition IDLE to CONNECTED

Figure B.1 provides an example C-plane flow for the IDLE to CONNECTED transition for Rel-8.

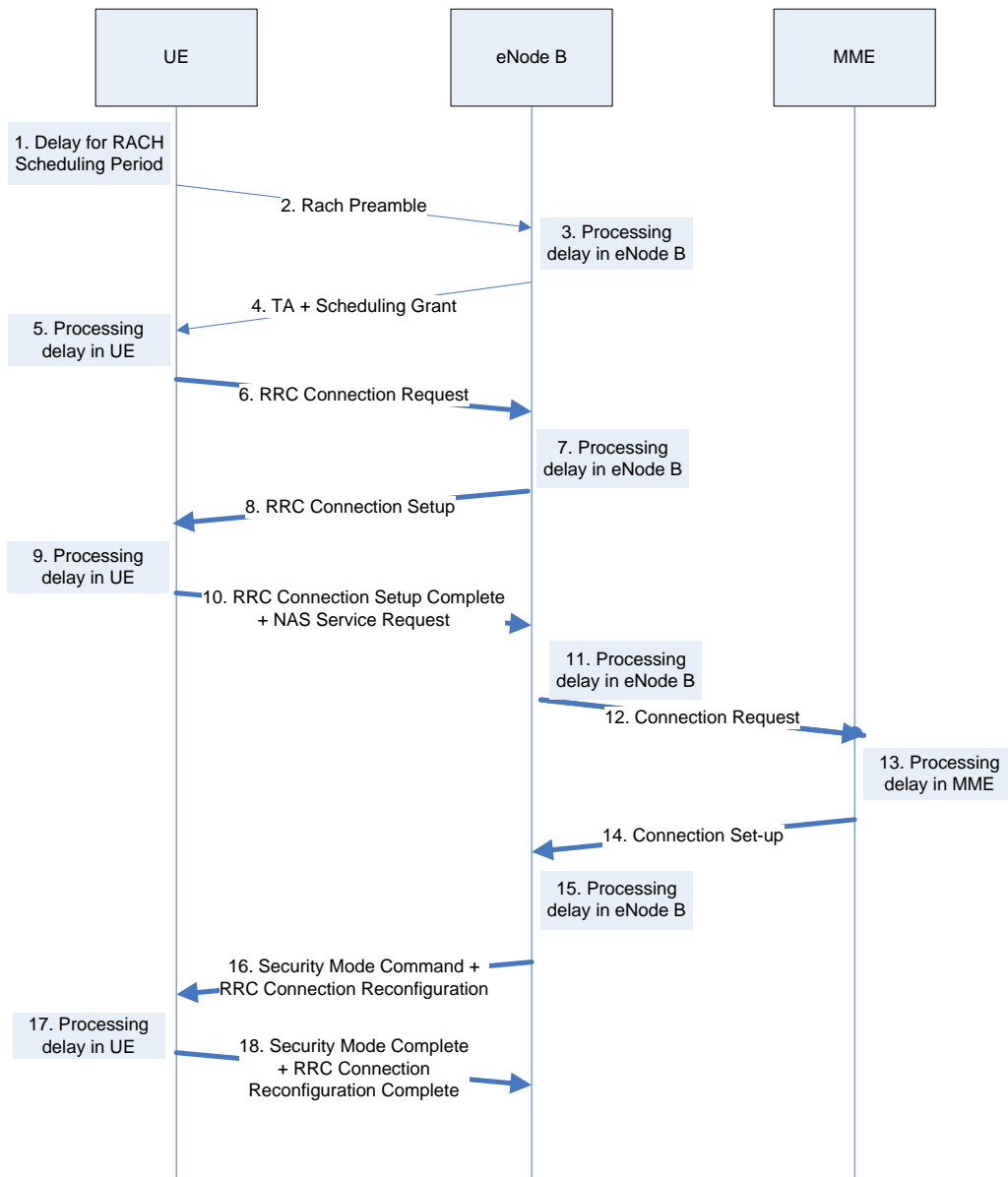

Figure B.1.1-1: C-plane activation procedure (example for Rel-8)

B.1.1.1 FDD frame structure

Table B.1.1.1-1 provides a timing analysis, assuming FDD frame structure, of the flow depicted in Figure B.1.1-1. The analysis illustrates that the state transition from IDLE to CONNECTED can be achieved within a minimum of 76ms,

with 3ms msg2 window and 1ms PRACH cycle. Considering more reasonable settings (5ms msg2 window and 5ms PRACH cycle), a 80ms transition time is achieved.

**Table B.1.1.1-1: C-plane latency analysis for Rel-8
(based on the procedure depicted in Figure B.1.1-1)**

Component	Description	Minimum [ms]	Average [ms]
1	Average delay due to RACH scheduling period	0.5	2.5
2	RACH Preamble	1	1
3-4	Preamble detection and transmission of RA response (Time between the end RACH transmission and UE's reception of scheduling grant and timing adjustment)	3	5
5	UE Processing Delay (decoding of scheduling grant, timing alignment and C-RNTI assignment + L1 encoding of RRC Connection Request)	5	5
6	Transmission of RRC Connection Request	1	1
7	Processing delay in eNB (L2 and RRC)	4	4
8	Transmission of RRC Connection Set-up (and UL grant)	1	1
9	Processing delay in the UE (L2 and RRC)	15	15
10	Transmission of RRC Connection Set-up complete (including NAS Service Request)	1	1
11	Processing delay in eNB (Uu → S1-C)	4	4
12	S1-C Transfer delay	T_S1	T_S1
13	MME Processing Delay (including UE context retrieval of 10ms)	15	15
14	S1-C Transfer delay	T_S1	T_S1
15	Processing delay in eNB (S1-C → Uu)	4	4
16	Transmission of RRC Security Mode Command and Connection Reconfiguration (+TTI alignment)	1.5	1.5
17	Processing delay in UE (L2 and RRC)	20	20
	Total delay [ms]	76	80

Note 1: The figures included in Steps 12 and 14 are not included in the latency requirement and are outside the scope of RAN WG2, therefore they are not included in the total delay.

B.1.1.2 TDD frame structure

Table B.1.1.2-1 provides a timing analysis, assuming TDD frame structure (UL/DL configuration #1), of the flow depicted in Figure B.1.1-1. The analysis illustrates that the state transition from IDLE to CONNECTED can be achieved within a minimum of 82.6ms, with 3ms msg2 window and maximum PRACH density in time domain (e.g. PRACH configuration Index = 12). Considering more reasonable settings (5ms msg2 window and 5ms PRACH cycle), a 84.6ms transition time is achieved.

Table B.1.1.2-1: C-plane latency analysis for Rel-8 (based on the procedure depicted in B.1.1-1)

Component	Description	Rel-8	Rel-8	Rel-8
		Minimum(ms) PRACH in subframe#2/ #3/ #7/ #8		Average [ms] PRACH in subframe#1/ #6
		Msg1 in subframe#2 or #7 (probability=0.8)	Msg1 in subframe#3 or #8 (probability=0.2)	Msg1 in subframe#1 or #6
1	Average delay due to RACH scheduling period	2	0.5	2.5
2	RACH Preamble	1	1	1
3-4	Preamble detection and transmission of RA response (Time between the end RACH transmission and UE's reception of scheduling grant and timing adjustment) + delay for nearest DL subframe	3	3	5
5	UE Processing Delay (decoding of scheduling grant, timing alignment and C-RNTI assignment + L1 encoding of RRC Connection Request) + delay for nearest UL subframe	6	5	5
6	Transmission of RRC Connection Request	1	1	1
7	Processing delay in eNB (L2 and RRC) + delay for nearest DL subframe	6	6	6
8	Transmission of RRC Connection Set-up (and UL grant)	1	1	1
9	Processing delay in the UE (L2 and RRC) + delay for nearest UL subframe	17	17	17
10	Transmission of RRC Connection Set-up complete (including NAS Service Request)	1	1	1
11	Processing delay in eNB (Uu → S1-C)	4	4	4
12	S1-C Transfer delay	T_S1	T_S1	T_S1
13	MME Processing Delay (including UE context retrieval of 10ms)	15	15	15
14	S1-C Transfer delay	T_S1	T_S1	T_S1
15	Processing delay in eNB (S1-C → Uu)	4	4	4
16	Transmission of RRC Security Mode Command and Connection Reconfiguration (+TTI alignment)	2.1	2.1	2.1
17	Processing delay in UE (L2 and RRC)	20	20	20
	Total delay [ms]	83.1	80.6	84.6
	Averaged Total delay [ms] (considering the probability of Msg1 transmission location)	83.1*0.8+ 80.6*0.2=82.6		N/A

Note 2: The figures included in Steps 12 and 14 are not included in the latency requirement and are outside the scope of RAN WG2, therefore they are not included in the total delay.

B.1.2 Transition Dormant to Active

In the dormant state, the UE has an established RRC connection and radio bearers; it is thus known at cell level but may be in DRX to save power during temporary inactivity. The UE may be either synchronized or unsynchronized. For the purpose of the analysis presented in this section, error free transmission of data and signalling is assumed, and the DRX cycle is not considered.

B.1.2.1 FDD frame structure

B.1.2.1.1 Uplink initiated transition, synchronized

Table B.1.2.1.1-1 provides a timing analysis, assuming FDD frame structure and a PUCCH allocation for scheduling request of 5ms, of the uplink state transition for a UE with uplink synchronization. The analysis illustrates that the uplink transition from dormant to active for a synchronized UE can be achieved within 11.5ms.

Table B.1.2.1.1-1: Uplink initiated dormant to active transition for synchronized UE (error free)

Component	Description	Time [ms]
1	Average delay to next SR opportunity (5ms PUCCH cycle)	2.5
2	UE sends Scheduling Request	1
3	eNB decodes Scheduling Request and generates the Scheduling Grant	3
4	Transmission of Scheduling Grant	1
5	UE Processing Delay (decoding of scheduling grant + L1 encoding of UL data)	3
6	Transmission of UL data	1
	Total delay	11.5

B.1.2.1.2 Uplink initiated transition, unsynchronized

Table B.1.2.1.2-1 provides a timing analysis of the uplink state transition for a UE without uplink synchronization. The analysis illustrates that the uplink transition from dormant to active for an unsynchronized UE can be achieved within a minimum of 10.5ms, with 1ms PRACH cycle and a 3ms msg2 window.

Table B.1.2.1.2-1: Uplink initiated dormant to active transition for unsynchronized UE (error free)

Component	Description	Minimum [ms]	Average [ms]
1	Average delay due to RACH scheduling period	0.5	2.5
2	RACH Preamble	1	1
3	Preamble detection and transmission of RA response (Time between the end of RACH transmission and UE's reception of scheduling grant and timing adj.)	3	5
4	UE Processing Delay (decoding of scheduling grant and timing alignment + L1 encoding of UL data)	5	5
5	Transmission of UL data	1	1
	Total delay	10.5	14.5

B.1.2.1.3 Downlink initiated transition, synchronized

A UE with uplink synchronization monitors PDCCH during the on-duration time of the DRX cycle, and there is thus no additional delay component apart from the DRX cycle when compared to the case of the uplink initiated for a synchronized UE.

B.1.2.1.4 Downlink initiated transition, unsynchronized

Table B.1.2.1.4-1 provides a timing analysis, assuming FDD frame structure, of the downlink state transition for a UE without uplink synchronization. For the downlink initiated transition, a dedicated preamble is assumed and no contention resolution is needed. The analysis illustrates that the downlink transition from dormant to active for an unsynchronized UE can be achieved within a minimum of 13.5ms, with 1ms PRACH cycle and a 3ms msg2 window.

Table B.1.2.1.4-1: Downlink initiated dormant to active transition (error free)

Component	Description	Minimum [ms]	Average [ms]
1	UE receives dedicated preamble on PDCCH and prepares UL Tx and cannot select a PRACH occasion before n+6	6	6
2	Average delay due to RACH scheduling period	0.5	2.5
3	RACH Preamble	1	1
4	Preamble detection and transmission of RA response (Time between the end RACH transmission and UE's reception of the timing adjustment)	3	5
5	Node B needs to wait 2 subframes before DL Tx to allow UE to adapt UL response according to the time alignment	2	2
6	Transmission of DL data	1	1
	Total delay [ms]	13.5	17.5

B.1.2.2 TDD frame structure

B.1.2.2.1 Uplink initiated transition, synchronized

Table B.1.2.2.1-1 provides a timing analysis, assuming TDD frame structure (UL/DL configuration#1) and a PUCCH allocation for scheduling request of 5ms, of the uplink state transition for a UE with uplink synchronization. The analysis illustrates that the uplink transition from dormant to active for a synchronized UE can be achieved within 13.5ms.

Table B.1.2.2.1-1: Uplink initiated dormant to active transition for synchronized UE (error free)

Component	Description	Time [ms]	Time [ms]
		SR in subframe# 2 or #7	SR in subframe#3 or #8
1	Average delay to next SR opportunity (5ms PUCCH cycle)	2.5	2.5
2	UE sends Scheduling Request	1	1
3	eNB decodes Scheduling Request and generates the Scheduling Grant + delay for nearest DL subframe	3	5
4	Transmission of Scheduling Grant	1	1
5	UE Processing Delay (decoding of scheduling grant + L1 encoding of UL data)	5	3
6	Transmission of UL data + delay for nearest UL subframe	1	1
	Total delay	13.5	13.5

B.1.2.2.2 Uplink initiated transition, unsynchronized

Table B.1.2.2.2-1 provides a timing analysis, assuming TDD frame structure (UL/DL configuration#1) and RACH cycle of 10ms, of the uplink state transition for a UE without uplink synchronization. The analysis illustrates that the uplink transition from dormant to active for an unsynchronized UE can be achieved within a minimum of 12.5ms, with 3ms msg2 window and maximum PRACH density in time domain (e.g. PRACH configuration Index=12).

Table B1.2.2.2-1: Uplink initiated dormant to active transition for unsynchronized UE (error free)

Component	Description	Minimum(ms) PRACH in subframe#2/ #3/ #7/ #8		Average [ms] PRACH in subframe#1 / #6
		Msg1 in subframe#2 or #7 (probability= 0.8)	Msg1 in subframe# 3 or #8 (probability =0.2)	Msg1 in subframe#1 or #6
1	Average delay due to RACH scheduling period	2	0.5	2.5
2	RACH Preamble	1	1	1
3	Preamble detection and transmission of RA response (Time between the end of RACH transmission and UE's reception of scheduling grant and timing adj.) + delay for nearest DL subframe	3	3	5
4	UE Processing Delay (decoding of scheduling grant and timing alignment + L1 encoding of UL data) + delay for nearest UL subframe	6	5	5
5	Transmission of UL data	1	1	1
	Total delay	13	10.5	14.5
	Averaged Total delay [ms] (considering the probability of Msg1 transmission location)	12.5		N/A

B.1.2.2.3 Downlink initiated transition, synchronized

A UE with uplink synchronization monitors PDCCH during the on-duration time of the DRX cycle, and there is thus no additional delay component apart from the DRX cycle when compared to the case of the uplink initiated for a synchronized UE.

B.1.2.2.4 Downlink initiated transition, unsynchronized

Tables B.1.2.2.4-1a and B.1.2.2.4-1b provide a timing analysis, assuming TDD frame structure (UL/DL configuration#1), of the downlink state transition for a UE without uplink synchronization. For the downlink initiated transition, a dedicated preamble is assumed and no contention resolution is needed. The analysis illustrates that the downlink transition from dormant to active for an unsynchronized UE can be achieved within a minimum of 16.5ms, with 3ms msg2 window and maximum PRACH density in time domain (e.g. PRACH configuration Index=12).

Table B.1.2.2.4-1a: Downlink initiated dormant to active transition (error free)

Component	Description	Minimum(ms) PRACH in subframe#2/ #3/ #7/ #8		
		PDCCH in subframe#0 or #5 (probability=0.2)	PDCCH in subframe#1 or #6 (probability=0.2)	PDCCH in subframe#4 or #9 (probability=0.6)
1	Average delay due to PDCCH transmission	0.5	0.5	1.5
2	UE receives dedicated preamble on PDCCH and prepares UL Tx+ delay for nearest PRACH	7	6	8
3	RACH Preamble	1	1	1
4	Preamble detection and transmission of RA response (Time between the end RACH transmission and UE's reception of the timing adjustment) + delay for nearest DL subframe	3	3	3
5	Node B needs to wait 2 subframes before DL Tx to allow UE to adapt UL response according to the time alignment+ delay for nearest DL subframe	3	3	3
6	Transmission of DL data	1	1	1
	Total delay [ms]	15.5	14.5	17.5
	Averaged Total delay [ms] (considering the probability of PDCCH transmission location)	16.5		

Table B.1.2.2.4-1b: Downlink initiated dormant to active transition (error free)

Component	Description	Average [ms] PRACH in subframe#1/ #6		
		PDCCH in subframe#0 or #5 (probability=0.2)	PDCCH in subframe#1 or #6 (probability=0.2)	PDCCH in subframe#4 or #9 (probability=0.6)
1	Average delay due to PDCCH transmission	0.5	0.5	1.5
2	UE receives dedicated preamble on PDCCH and prepares UL Tx+ delay for nearest PRACH	6	10	7
3	RACH Preamble	1	1	1
4	Preamble detection and transmission of RA response (Time between the end RACH transmission and UE's reception of the timing adjustment) + delay for nearest DL subframe	5	5	5
5	Node B needs to wait 2 subframes before DL Tx to allow UE to adapt UL response according to the time alignment+ delay for nearest DL subframe	2	2	2
6	Transmission of DL data	1	1	1
	Total delay [ms]	15.5	19.5	17.5
	Averaged Total delay [ms] (considering the probability of PDCCH transmission location)	17.5		

B.2 U-plane latency

B.2.1 FDD frame structure

The LTE U-plane one way latency for a scheduled UE consists of the fixed node processing delays (which includes radio frame alignment) and 1ms TTI duration for FDD as shown in Figure B.2.1-1. Considering that the number of HARQ processes is fixed to 8 for FDD, the one-way latency can be calculated as:

$$DUP [ms] = 1.5 + 1 + 1.5 + n \cdot 8 = 4 + n \cdot 8,$$

where n is the number of HARQ retransmissions. Considering a typical case where there would be 0 or 1 retransmission, the approximate average U-plane latency is given by

$$D_{UP,typical} [ms] = 4 + p \cdot 8,$$

where p is the error probability of the first HARQ retransmission. The minimum latency is achieved for a 0% BLER, but a more reasonable setting is 10% HARQ BLER.

$$D_{UP,0\%HARQ_BLER} [ms] = 4 \quad (0\% \text{ HARQ BLER})$$

$$D_{UP,10\%HARQ_BLER} [ms] = 4.8 \quad (10\% \text{ HARQ BLER})$$

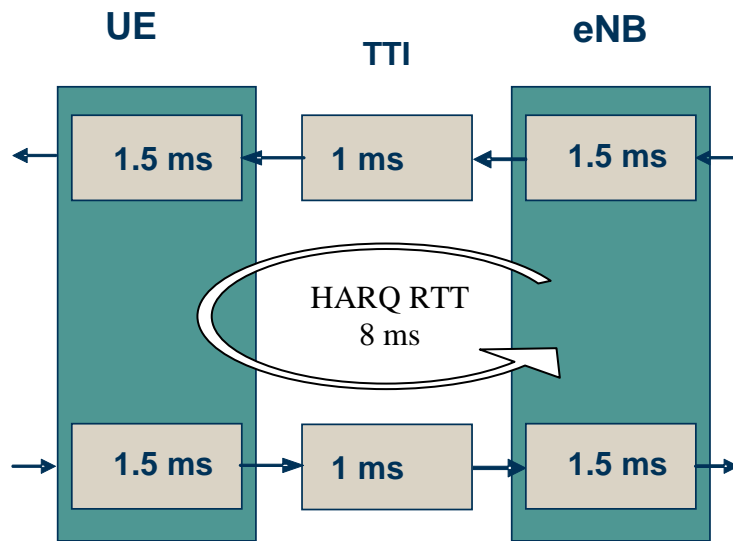
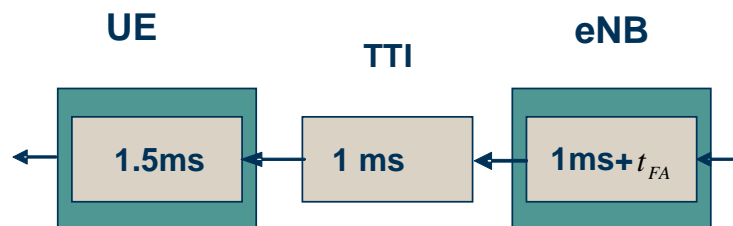

Figure B.2.1-1: User plane latency components for FDD

B.2.2 TDD frame structure

The LTE U-plane one way latency for a scheduled UE consists of the fixed node processing delays, radio frame alignment and TTI duration for TDD as shown in Figure B.2.2-1.



(a) Downlink

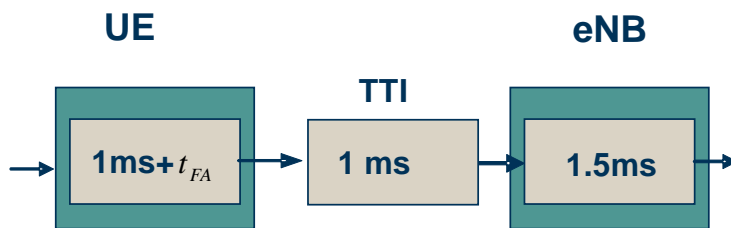

(b) Uplink

Figure B.2.2-1: User plane latency components for TDD

Where:

- a) The total one-way processing time is 2.5ms.
- b) is radio frame alignment and depends on the frame structure.
- c) The TTI duration is 1ms.

Based on the assumptions above, the LTE U-plane latency is given by:

$$D_{UP} [ms] = 1 + t_{FA} + 1 + 1.5 + n \cdot p$$

where t_{FA} is the average HARQ RTT and n is the number of HARQ retransmissions. In typical cases there would be 0 or 1 re-transmissions yielding an approximate average U-plane latency of

$$D_{UP,typical} [ms] = 3.5 + p$$

where p is the error probability of the first HARQ transmission. Tables B.2.2-2a and B.2.2-2b show the U-plane latency in downlink and uplink, respectively, for different TDD UL/DL configuration when 0% HARQ BLER is assumed.

Table B.2.2-2a: U-plane latency analysis with 0% HARQ BLER (average in downlink)

Step	Description	UL/DL configuration						
		0	1	2	3	4	5	6
1	eNB Processing Delay	1ms	1ms	1ms	1ms	1ms	1ms	1ms
2	Frame Alignment	1.7ms	1.1ms	0.7ms	1.1ms	0.8ms	0.6ms	1.4ms
3	TTI duration	1ms	1ms	1ms	1ms	1ms	1ms	1ms
4	UE Processing Delay	1.5ms	1.5ms	1.5ms	1.5ms	1.5ms	1.5ms	1.5ms
	Total one way delay	5.2ms	4.6ms	4.2ms	4.6ms	4.3ms	4.1ms	4.9ms

Table B.2.2-2b: U-plane latency analysis with 0% HARQ BLER (average in uplink)

Step	Description	UL/DL configuration						
		0	1	2	3	4	5	6
1	UE Processing Delay	1ms	1ms	1ms	1ms	1ms	1ms	1ms
2	Frame Alignment	1.1ms	1.7ms	2.5ms	3.3ms	4.1ms	5ms	1.4ms
3	TTI duration	1ms	1ms	1ms	1ms	1ms	1ms	1ms
4	eNB Processing Delay	1.5ms	1.5ms	1.5ms	1.5ms	1.5ms	1.5ms	1.5ms
	Total one way delay	4.6ms	5.2ms	6ms	6.8ms	7.6ms	8.5ms	4.9ms

Tables B.2.2-3a and B.2.2-3b show the U-plane latency in downlink and uplink, respectively, for different TDD UL/DL configuration when 10% HARQ BLER is assumed.

Table B.2.2-3a: U-plane latency analysis with 10% HARQ BLER (average in downlink)

Step	Description	UL/DL configuration						
		0	1	2	3	4	5	6
1	eNB Processing Delay	1ms	1ms	1ms	1ms	1ms	1ms	1ms
2	Frame Alignment	1.7ms	1.1ms	0.7ms	1.1ms	0.8ms	0.6ms	1.4ms
3	TTI duration	1ms	1ms	1ms	1ms	1ms	1ms	1ms
4	UE Processing Delay	1.5ms	1.5ms	1.5ms	1.5ms	1.5ms	1.5ms	1.5ms
5	HARQ Retransmission	0.1*10ms	0.1*10.2ms	0.1*9.8ms	0.1*10.5ms	0.1*11.6ms	0.1*12.4ms	0.1*11.2ms
	Total one way delay	6.2ms	5.62ms	5.18ms	5.65ms	5.46ms	5.34ms	6.02ms

Table B.2.2-3b: U-plane latency analysis with 10% HARQ BLER (average in uplink)

Step	Description	UL/DL configuration						
		0	1	2	3	4	5	6
1	UE Processing Delay	1ms	1ms	1ms	1ms	1ms	1ms	1ms
2	Frame Alignment	1.1ms	1.7ms	2.5ms	3.3ms	4.1ms	5ms	1.4ms
3	TTI duration	1ms	1ms	1ms	1ms	1ms	1ms	1ms
4	eNB Processing Delay	1.5ms	1.5ms	1.5ms	1.5ms	1.5ms	1.5ms	1.5ms
5	HARQ Retransmission	0.1*11.6ms	0.1*10ms	0.1*10ms	0.1*10ms	0.1*10ms	0.1*10ms	0.1*11.5ms
	Total one way delay	5.76ms	6.2ms	7ms	7.8ms	8.6ms	9.5ms	6.05ms

Note: The analysis shows that the 5ms U-plane latency requirement can be simultaneously satisfied in TDD for both uplink and downlink using the UL/DL configuration #6 when 0% HARQ BLER is assumed.

Annex C: ITU-R Submission Templates

The submission of the 3GPP "LTE Release 10 & beyond (LTE-Advanced)" to the ITU-R as a candidate technology for the IMT-Advanced must include completed templates according to Report ITU-R M.2133 [7].

C.1 Description template – characteristics (4.2.3.2)

The 3GPP description template – characteristics (4.2.3.2) for both the FDD and the TDD component is found in RP-090745 [14].

C.2 Description template – link budget (4.2.3.3)

The 3GPP description template – link budget (4.2.3.3) for both the FDD and the TDD component is found in RP-090746 [15].

C.3 Compliance templates for services (4.2.4.1), for spectrum (4.2.4.2), technical performance (4.2.4.3)

The 3GPP compliance templates for services (4.2.4.1), for spectrum (4.2.4.2), technical performance (4.2.4.3) for both the FDD and the TDD component is found in RP-090747 [16].

Annex D: Change history

Change history							
Date	TSG #	TSG Doc.	CR	Rev	Subject/Comment	Old	New
2009/03	R1#56bis	R1-091661			Skeleton TR is endorsed	0.0.0	0.1.0
2009/08	R1#58	R1-093685			Capture the agreement in RAN1#57bis, RAN2#66 and #66bis	0.1.2	0.2.0
2009/08	R1#58	R1-093716			Capture the agreement in RAN1#58, RAN2#67 and RAN4#52	0.2.0	0.2.1
2009/08	R1#58	R1-093736			Version 0.2.1 was endorsed to v2.0.0	0.2.1	2.0.0
2009/08					Correction by RAN1. Some editorial corrections by ITU ad hoc	2.0.0	2.1.1
					Editorial corrections by editor	2.1.1	2.1.2
2009/09	RAN_45	RP-090737			Submit to RAN for approval		2.2.0
2009/09	RAN_45	RP-090743			Version 2.2.0 was approved to v9.0.0	2.2.0	9.0.0
01/12/09	RAN_46	RP-091173	0001	-	Editorial correction on TR36.912	9.0.0	9.1.0
01/12/09	RAN_46	RP-091173	0002	-	Updates on TR36.912	9.0.0	9.1.0
01/12/09	RAN_46	RP-091173	0003	-	RAN2 agreements on Carrier aggregations, PDCP and Contention based uplink	9.0.0	9.1.0
16/03/10	RAN_47	RP-100212	0004	-	Conclusion of TR36.912	9.1.0	9.2.0
16/03/10	RAN_47	RP-100212	0005	-	Type 1 Relay definition	9.1.0	9.2.0
16/03/10	RAN_47	RP-100212	0006	-	Performance evaluation of LTE-A technologies against 3GPP targets	9.1.0	9.2.0
16/03/10	RAN_47	RP-100212	0007	1	U-Plane interruption for TDD RIT	9.1.0	9.2.0
03/06/10	RAN_48	RP-100574	0009	-	Clarification of operating band for LTE-A	9.2.0	9.3.0
21/03/11	SP_51	-	-	-	Upgrade to Rel-10 following decision made at SP_51	9.3.0	10.0.0
2012-09	SP_57	-	-	-	Update to Rel-11 version (MCC)	10.0.0	11.0.0