

# 3GPP TS 36.523-3 V11.1.0 (2013-09)

---

*Technical Specification*

**3rd Generation Partnership Project;  
Technical Specification Group Radio Access Network;  
Evolved Universal Terrestrial Radio Access (E-UTRA)  
and Evolved Packet Core (EPC);  
User Equipment (UE) conformance specification  
Part 3: Test Suites  
(Release 11)**

---



Keywords

---

EPC, E-UTRA, mobile, terminal, testing, UE

**3GPP**

---

Postal address

---

3GPP support office address

---

650 Route des Lucioles - Sophia Antipolis  
Valbonne - FRANCE  
Tel.: +33 4 92 94 42 00 Fax: +33 4 93 65 47 16

---

Internet

---

<http://www.3gpp.org>

---

**Copyright Notification**

No part may be reproduced except as authorized by written permission.  
The copyright and the foregoing restriction extend to reproduction in all media.

© 2013, 3GPP Organizational Partners (ARIB, ATIS, CCSA, ETSI, TTA, TTC).  
All rights reserved.

UMTS™ is a Trade Mark of ETSI registered for the benefit of its members  
3GPP™ is a Trade Mark of ETSI registered for the benefit of its Members and of the 3GPP Organizational Partners  
LTE™ is a Trade Mark of ETSI registered for the benefit of its Members and of the 3GPP Organizational Partners  
GSM® and the GSM logo are registered and owned by the GSM Association

# Contents

Foreword .....	10
Introduction .....	10
1 Scope .....	11
2 References.....	11
3 Definitions and abbreviations .....	14
3.1 Definitions .....	14
3.2 Abbreviations.....	14
4 E-UTRAN/SAE system architecture and test models .....	14
4.1 Test system architecture .....	14
4.1.1 General system architecture .....	14
4.1.2 Component architecture .....	15
4.2 E-UTRAN test models .....	16
4.2.1 Layer 2 test models .....	16
4.2.1.1 MAC test model.....	17
4.2.1.2 RLC test model.....	18
4.2.1.3 PDCP test model .....	19
4.2.1.3.1 PDCP ROHC test model.....	19
4.2.1.3.2 PDCP test model (Non ROHC) .....	20
4.2.2 RRC test model.....	21
4.2.3 DRB test model .....	22
4.2.4 IP Test Model.....	23
4.2.4.1 IP user data.....	23
4.2.4.2 Configuration of Sockets .....	24
4.2.4.2.1 Socket Establishment .....	24
4.2.4.2.2 Socket Release.....	25
4.2.4.3 Handling of IP data.....	25
4.2.4.4 Routing of IP Data .....	26
4.2.4.5 Multiple PDNs.....	26
4.2.4.6 IP Addresses Guide lines .....	27
4.2.4.6.1 Common Structure of IP Addresses .....	27
4.2.4.6.2 Common Requirements regarding IP Addresses.....	27
4.2.4.7 User Plane Signalling for Address Allocation .....	28
4.2.4.7.1 DHCP.....	28
4.2.4.7.2 DHCPv6 .....	31
4.2.4.7.3 ICMPv6 .....	31
4.2.4.7.4 DNS.....	32
4.2.4A LTE-Carrier Aggregation test Models.....	33
4.2.4A.1 CA-MAC test model .....	33
4.2.4A.2 CA-RRC test model .....	34
4.2.5 IP model extension for IMS .....	35
4.2.5.1 IPsec .....	36
4.2.5.1.1 Security Association.....	36
4.2.5.1.2 SAD and SPD .....	37
4.2.5.2 Signalling Compression (Sig Comp) .....	38
4.2.5.3 SIP TTCN-3 Codec .....	39
4.2.6 Support of DSM IPv6.....	39
4.2.7 MBMS test model .....	40
4.3 SAE Test Model .....	41
4.3.1 NAS Test Model.....	41
4.4 Inter RAT Test Model .....	42
4.4.1 E-UTRAN-UTRAN Inter RAT Test Model.....	42
4.4.1.1 User data over UTRAN .....	42
4.4.1.1.1 Raw user data over UTRAN .....	43
4.4.1.1.2 IP data over UTRAN.....	43

4.4.1.1.3	Routing IP data.....	44
4.4.2	E-UTRAN-GERAN Inter RAT Test Model.....	45
4.4.2.1	User data over GERAN .....	45
4.4.2.1.1	Raw user data over GERAN .....	46
4.4.2.1.2	IP data over GERAN.....	46
4.4.2.1.3	Routing IP data.....	47
4.4.3	E-UTRAN-CDMA2000 Inter RAT Test Model.....	48
4.4.3.1	E-UTRAN-CDMA2000 HRPD Inter RAT Test Model.....	48
4.4.3.2	E-UTRAN-CDMA2000 1xRTT Inter RAT test model .....	50
4.4.4	E-UTRAN FDD-TDD Inter RAT Test Model.....	53
4.4.5	E-UTRAN-UTRAN-GERAN Inter RAT Test Model.....	54
5	Upper Tester Interface.....	54
6	ASP specifications .....	57
6.1	General Requirements and Assumptions.....	57
6.1.1	IP ASP requirements .....	58
6.1.2	Enhancement of IP ASP for handling IMS signalling .....	58
6.2	E-UTRAN ASP Definitions .....	59
6.2.1	Configuration Primitives.....	59
6.2.2	Signalling Primitives .....	59
6.2.3	Co-ordination Messages between NAS Emulation PTC and EUTRA PTC .....	60
6.3	UTRAN ASP Definitions.....	61
6.3.1	Void .....	62
6.3.2	ASPs for Data Transmission and Reception.....	62
6.4	GERAN ASP Definitions.....	63
6.4.1	ASPs for Control Primitive Transmission .....	63
6.4.2	ASPs for Data Transmission and Reception.....	65
7	Test Methods and Design Considerations .....	68
7.1	Channel Mapping .....	68
7.1.1	PDCCH Candidate Selection .....	68
7.1.1.1	FDD candidates selection.....	69
7.1.1.2	TDD candidates selection.....	72
7.2	Uplink Grant.....	74
7.2.1	Exception TC list.....	76
7.3	Downlink Resource Allocation .....	76
7.3.1	PDCCH DCI default formats .....	77
7.3.1.1	Default DCI Format to be used in test cases configuring MIMO .....	77
7.3.2	Radio parameters configured .....	77
7.3.2.1	HARQ Retransmission when MIMO is configured .....	78
7.3.3	General DL scheduling scheme .....	78
7.3.3.1	Additional rules for BCCH scheduling scheme.....	78
7.3.3.1.1	BCCH with DCI combination 1 .....	79
7.3.3.1.2	BCCH with DCI combination 2 .....	79
7.3.3.2	Additional rules for PCCH specific scheduling scheme .....	79
7.3.3.2.1	PCCH with DCI combination 1.....	79
7.3.3.2.2	PCCH with DCI combination 2.....	79
7.3.3.3	Additional rules for RAR specific scheduling scheme.....	80
7.3.3.3.1	RAR with DCI combination 1 .....	80
7.3.3.3.2	RAR with DCI combination 2 .....	80
7.3.3.4	Additional rules for UE-dedicated scheduling scheme in normal mode.....	80
7.3.3.5	DL Resource allocation bitmaps .....	82
7.3.3.5.1	DCI combination 1 .....	82
7.3.3.5.2	DCI combination 2 .....	83
7.3.3.6	UE-dedicated scheduling scheme in explicit mode .....	85
7.3.3.6.1	DL Scheduling in Transport Block Size Selection Test Cases .....	86
7.3.3.7	Resource allocation sheets .....	86
7.4	Cell Configurations .....	87
7.4.1	Cell Configuration Types.....	87
7.4.2	Cell Power Change .....	88
7.4.3	E-UTRAN cell identity .....	88
7.4.3.1	Timing parameters of cells .....	88

7.4.4	Cell configurations for NAS test cases.....	90
7.4.5	Configuration of Multi-Cell Environment.....	90
7.5	TDD Considerations.....	91
7.5.1	FDD vs. TDD implementation.....	91
7.5.2	Guideline for FDD vs. TDD verification.....	91
7.6	Special RLC Modes.....	91
7.6.1	Suppression of RLC Acknowledgements.....	91
7.6.2	Modification of VT(S).....	92
7.7	System information.....	92
7.7.1	System information broadcasting.....	92
7.7.2	Scheduling information.....	93
7.7.3	System information modification.....	96
7.7.3.1	Non-PWS System Information modification.....	96
7.7.3.1.1	UE in Idle_mode.....	96
7.7.3.1.2	UE in connected mode.....	96
7.7.3.2	PWS System Information modification.....	97
7.8	Timers and Timing Restrictions.....	97
7.8.1	Auxiliary timers.....	97
7.8.2	RRC timers reconfiguration.....	97
7.8.3	MAC TA timer reconfiguration.....	97
7.8.4	Non-protocol timers.....	98
7.9	Error Indication.....	98
7.10	Race Conditions.....	98
7.11	Radio Link Failure.....	98
7.12	Test method for RRC signalling latency.....	99
7.12.1	Procedure delays in PUCCH synchronized state.....	99
7.12.2	Procedure delays when RACH procedure required.....	100
7.13	RLC test method for scheduled data.....	101
7.14	IP packets for Loopback Mode.....	102
7.14.1	IP packets used for Loopback Mode A.....	102
7.14.2	IP packets used for Loopback Mode B.....	102
7.15	Connected Mode DRX.....	102
7.16	Handover Sequences.....	104
7.16.1	Sequence of inter-cell handover.....	104
7.16.2	Sequence of intra-cell handover.....	105
7.16.3	UL Grants used in RA procedure during handover.....	105
7.17	Simulation of PDCP MAC-I Failure in UE.....	105
7.17.1	Integrity and ciphering not yet activated.....	106
7.17.2	Integrity and/or ciphering already activated.....	106
7.18	RRC Connection Release Sequence.....	106
7.19	DL CCCH Message and Contention Resolution MAC Control Element transmission in one MAC PDU or in separate MAC PDUs.....	107
7.20	RRC Connection Reconfiguration Sequence (Measurement Control).....	107
7.21	GERAN special issues.....	107
7.21.1	Timeslot assigned for GERAN CS traffic.....	107
7.21.2	Subchannel used in GERAN L2 access message.....	108
7.22	EUTRAN RSRQ Calculations.....	108
7.22.1	Assumptions.....	108
7.22.2	The Ideal Calculation.....	108
7.22.3	Additional RSRQ Calculations For Fixing Boundary Values.....	108
7.23	Test method for eCIC.....	109
7.24	Carriage Aggregation Signalling Sequences.....	109
7.24.1	Initial configuration of Pcell.....	109
7.24.2	Initial configuration of SCell.....	110
7.24.3	Scell Addition and/or release.....	111
7.25	Test method for MBMS.....	111
7.25.1	Schedule transmission of MCCH messages.....	111
7.25.2	MCCH change notification.....	112
7.25.3	MTCH data scheduling.....	112
8	External Function Definitions.....	112

9	IXIT Proforma .....	115
9.1	E-UTRAN PIXIT .....	115
9.2	MultiRAT PIXIT .....	116
10	Postambles .....	118
10.1	Postambles for E-UTRA to UTRA tests.....	118
10.1.1	UE postamble states and procedures for E-UTRA to UTRA .....	119
10.1.2	Switch/Power off procedure .....	120
10.1.2.1	Procedure.....	120
10.1.3	CC disconnect procedure .....	122
10.1.3.1	Procedure.....	122
10.1.4	PS Routing Area Update procedure .....	123
10.1.4.1	Procedure.....	123
10.1.5	CS fallback procedure .....	124
10.1.5.1	Procedure.....	124
10.2	Postambles for E-UTRAN to GERAN tests.....	126
10.2.1	UE postamble states and procedures for E-UTRA to GERAN test cases .....	126
10.2.2	Switch/Power off procedure .....	128
10.2.2.1	Procedure.....	128
10.2.3	PS Handover procedure.....	129
10.2.3.1	Procedure.....	129
10.2.4	CC disconnect procedure .....	130
10.2.4.1	Procedure.....	130
10.2.5	CS fallback procedure .....	130
10.2.5.1	Procedure.....	130
10.3	Postambles for E-UTRA test cases.....	131
10.3.1	UE postamble states and procedures for E-UTRA test cases .....	131
10.3.2	Switch/Power off procedure in State E1 .....	132
10.3.2.1	Procedure.....	132
10.3.3	Switch/Power off procedure in State E2 and E3 .....	133
10.3.3.1	Procedure for E2 and E3 .....	133
10.3.3.2	Procedure for E2_T3440 .....	134
10.3.4	Switch/Power off procedure in State E4 .....	135
10.3.4.1	Procedure.....	135
10.4	Postambles for E-UTRA to HRPD test cases .....	135
10.4.1	UE postamble procedures for E-UTRA to HRPD (No Pre-Registration) .....	135
10.4.1.1	Registration on HRPD Cell .....	135
10.4.1.2	Detach on HRPD Cell .....	136
11	Guidelines on test execution .....	136
11.1	EUTRA single technology .....	136
11.1.1	Replacement of test case execution.....	138
11.2	EUTRA – UTRA - GERAN .....	138
11.2.1	UTRA configured – GERAN not configured .....	138
11.2.1.1	EUTRA band overlapping UTRA band.....	138
11.2.1.2	EUTRA band not overlapping UTRA band .....	139
11.2.2	GERAN configured - UTRA not configured .....	140
11.2.3	Neither UTRA nor GERAN configured.....	141
11.2.4	Both UTRA and GERAN configured .....	141
11.2.4.1	EUTRA band overlapping UTRA band.....	141
11.2.4.2	EUTRA band not overlapping UTRA band .....	142
11.2.5	Replacement of test case execution.....	142
11.3	Guidelines for EUTRA inter-band .....	142
11.3.1	Primary operating band .....	142
11.3.2	Secondary operating band for inter-band cells.....	143
11.4	Guidelines for EUTRA CA .....	143
11.4.1	CA contiguous Intra-band operation.....	143
11.4.2	CA Inter-band operation .....	143
Annex A (normative):	Test Suites .....	144
A.1	Baseline of specifications .....	144

A.2	E-UTRA Test Suites.....	144
Annex B (informative):	Style Guides.....	156
B.1	Introduction.....	156
B.2	General Requirements for TTCN-3 Implementations .....	156
B.3	Naming Conventions .....	157
B.3.1	Prefixes and Restrictions for TTCN-3 Objects .....	157
B.3.2	Void .....	158
B.3.3	Void .....	158
B.3.4	Identifiers consisting of more than one Name .....	158
B.4	Implementation Issues.....	158
B.4.1	Control part.....	158
B.4.2	Top Level Test Case Definitions .....	158
B.4.3	Inter Component Communication .....	159
B.4.4	Encoding Information .....	159
B.4.5	Verdict Assignment.....	159
B.4.5.1	PASS verdict assignment.....	160
B.4.5.2	FAIL or INCONC verdict assignment.....	160
B.4.5.3	Verdict assignment in default behaviour.....	161
B.4.6	Default Behaviour .....	161
B.4.7	Templates for Sending and Receiving .....	162
B.4.8	Logging .....	162
B.4.8.1	Prose Step Numbers.....	162
B.4.9	Top level comments .....	163
B.4.10	Mapping of DRBs .....	163
B.5	Modularisation.....	163
Annex C (informative):	Design Principles.....	165
C.1	ASP Design .....	165
C.2	SS State Model.....	166
Annex D (informative):	TTCN-3 Definitions.....	169
D.1	EUTRA_ASP_TypeDefs.....	169
D.1.1	ASN1_Container .....	169
D.1.2	System_Configuration .....	175
D.1.3	Cell_Configuration .....	178
D.1.3.1	Cell_Configuration_Common .....	178
D.1.3.2	Downlink_Physical_Layer_Configuration .....	183
D.1.3.2.1	Antenna_Configuration .....	183
D.1.3.2.2	Physical_Channels.....	184
D.1.3.2.3	Physical_Signals .....	186
D.1.3.3	Uplink_Physical_Layer_Configuration.....	187
D.1.3.4	Common_MAC_Configuration .....	188
D.1.3.5	Random_Access_Procedure.....	195
D.1.3.6	System_Information_Control.....	201
D.1.3.7	Paging_Control.....	204
D.1.3.8	UE_Specific_Channel_Configuration .....	204
D.1.3.8.1	UE_Specific_Channel_Configuration_DL.....	204
D.1.3.8.1.1	MIMO_Configuration .....	204
D.1.3.8.2	UE_Specific_Channel_Configuration_UL.....	206
D.1.3.9	Carrier_Aggregation.....	208
D.1.4	Cell_Power_Attenuation.....	210
D.1.5	Radio_Bearer_Configuration .....	210
D.1.5.1	PDCP_Configuration.....	211
D.1.5.2	RLC_Configuration .....	212
D.1.5.3	MAC_Configuration.....	214
D.1.6	AS_Security.....	218

D.1.7	Semi_Persistent_Scheduling .....	219
D.1.8	Paging_Trigger .....	221
D.1.9	L1_MAC_Indication_Control .....	221
D.1.10	Rlc_Indication_Control .....	222
D.1.11	PDCP_Count .....	223
D.1.12	PDCP_Handover .....	224
D.1.13	L1_MAC_Test_Mode .....	224
D.1.14	PDCCH_Order .....	225
D.1.15	System_Indications .....	225
D.1.16	System_Interface .....	228
D.1.17	MBMS_Configuration .....	229
D.2	EUTRA_ASP_DrbDefs .....	232
D.2.1	PDU_TypeDefs .....	232
D.2.1.1	MAC_PDU .....	232
D.2.1.2	RLC_PDU .....	234
D.2.1.2.1	Common .....	234
D.2.1.2.2	TM_Data .....	235
D.2.1.2.3	UM_Data .....	236
D.2.1.2.4	AM_Data .....	237
D.2.1.2.5	AM_Status .....	238
D.2.1.3	PDCP .....	240
D.2.2	DRB_Primitive_Definitions .....	242
D.2.2.1	DRB_Common .....	243
D.2.2.2	Downlink .....	244
D.2.2.3	Uplink .....	245
D.2.3	MBMS_MRB_Primitive_Definitions .....	245
D.2.4	System_Interface .....	246
D.3	EUTRA_ASP_SrbDefs .....	247
D.3.1	SRB_DATA_ASFs .....	247
D.3.2	Port_Definitions .....	249
D.4	IP_ASP_TypeDefs .....	249
D.4.1	IP_Common .....	249
D.4.2	IP_Config .....	251
D.4.3	IPsec_Config .....	252
D.4.4	IP_SocketHandling .....	254
D.4.4.1	Socket_Common .....	254
D.4.4.2	Socket_Datagram .....	255
D.4.4.3	TCP_Socket .....	255
D.4.4.4	UDP_Socket .....	260
D.4.4.5	ICMP_Socket .....	262
D.4.4.6	Socket_Primitives .....	264
D.4.5	System_Interface .....	265
D.5	NasEmu_AspTypes .....	267
D.5.1	System_Interface .....	268
D.6	EUTRA_CommonDefs .....	269
D.6.1	Common_Types .....	269
D.6.2	Common_Constants .....	269
D.6.3	RRC_Nested_Types .....	270
D.6.4	ASP_CommonPart .....	270
D.6.4.1	ASP_CommonPart_Definitions .....	270
D.6.4.1.1	Routing_Info .....	270
D.6.4.1.2	Timing_Info .....	271
D.6.4.2	REQ_ASP_CommonPart .....	272
D.6.4.3	CNF_ASP_CommonPart .....	273
D.6.4.4	IND_ASP_CommonPart .....	273
D.6.5	CA_CommonDefs .....	274
D.6.6	MBMS_CommonDefs .....	275
D.7	CDMA2000_ASP_TypeDefs .....	275



D.7.1	CDMA2000_Common .....	275
D.7.1.1	CDMA2000_SystemContants.....	276
D.7.1.2	CDMA2000_Routing .....	276
D.7.1.3	CDMA2000_TimingInfo .....	276
D.7.1.4	CDMA2000_ReqAspCommonPart .....	278
D.7.1.5	CDMA2000_IndAspCommonPart .....	278
D.7.1.6	CDMA2000_CnfAspCommonPart .....	279
D.7.2	CDMA2000_PowerLevel .....	279
D.7.3	CDMA2000_Data .....	280
D.7.4	CDMA2000_CellConfiguration.....	282
D.7.5	CDMA2000_HRPD .....	284
D.7.5.1	CDMA2000_PDN_Defs .....	284
D.7.5.2	CDMA2000_SubProtocols.....	285
D.7.5.3	HRPD_Indications .....	287
D.7.5.4	HRPD_Commands.....	290
D.7.6	CDMA2000_RTT1X .....	293
D.7.6.1	RTT1X_Indications .....	293
D.7.6.2	RTT1X_Commands.....	296
D.7.7	System_Interface .....	298
D.8	CDMA2000_CommonDefs .....	301
D.9	HRPD_MsgTypeDefs.....	304
D.10	EUTRA_ASP_CDMA2000TunnellingDefs .....	307
D.11	EUTRA_ASP_VirtualNoiseDefs.....	309
D.12	UTRAN_ASP_VirtualNoiseDefs .....	310
D.13	CommonDefs.....	311
D.14	References to TTCN-3.....	314
Annex E (informative):	Change history .....	315

---

## Foreword

This Technical Specification has been produced by the 3<sup>rd</sup> Generation Partnership Project (3GPP).

The contents of the present document are subject to continuing work within the TSG and may change following formal TSG approval. Should the TSG modify the contents of the present document, it will be re-released by the TSG with an identifying change of release date and an increase in version number as follows:

Version x.y.z

where:

- x the first digit:
  - 1 presented to TSG for information;
  - 2 presented to TSG for approval;
  - 3 or greater indicates TSG approved document under change control.
- y the second digit is incremented for all changes of substance, i.e. technical enhancements, corrections, updates, etc.
- z the third digit is incremented when editorial only changes have been incorporated in the document.

---

## Introduction

The present document is part 3 of a multi-part conformance test specification for the 3GPP evolved User Equipment (UE). The specification contains a TTCN-3 design frame work and the detailed test specifications in TTCN-3 for evolved UE at the UE-E-UTRAN radio interface.

- 3GPP TS 36.523-1 [1]: "User Equipment (UE) conformance specification; Part 1: Protocol conformance specification".
- 3GPP TS 36.523-2 [2]: "User Equipment (UE) conformance specification; Part 2: Implementation Conformance Statement (ICS) proforma specification".
- **3GPP TS 36.523-3: "Test Suites"** (the present document).

---

# 1 Scope

The present document specifies the protocol and signalling conformance testing in TTCN-3 for the 3GPP UE at the UE-E-UTRAN radio interface.

The following TTCN test specification and design considerations can be found in the present document:

- the test system architecture;
- the overall test suite structure;
- the test models and ASP definitions;
- the test methods and usage of communication ports definitions;
- the test configurations;
- the design principles and assumptions;
- TTCN styles and conventions;
- the partial PIXIT proforma;
- the test suites.

The Abstract Test Suites designed in the document are based on the test cases specified in prose (3GPP TS 36.523-1 [1]). The applicability of the individual test cases is specified in the test ICS proforma specification (3GPP TS 36.523-2 [1]).

The present document is valid for TTCN development for LTE and LTE-A UE conformance test according to 3GPP Releases starting from Release 8 up to the Release indicated on the cover page of the present document.

---

# 2 References

The following documents contain provisions which, through reference in this text, constitute provisions of the present document.

- References are either specific (identified by date of publication, edition number, version number, etc.) or non-specific.
- For a specific reference, subsequent revisions do not apply.
- For a non-specific reference, the latest version applies. In the case of a reference to a 3GPP document (including a GSM document), a non-specific reference implicitly refers to the latest version of that document *in the same Release as the present document*.

- [1] 3GPP TS 36.523-1: "User Equipment (UE) conformance specification; Part 1: Protocol conformance specification".
- [2] 3GPP TS 36.523-2: "User Equipment (UE) conformance specification; Part 2: Implementation Conformance Statement (ICS) proforma specification".
- [3] 3GPP TS 36.508: "Common test environments for User Equipment (UE) conformance testing".
- [4] 3GPP TS 36.509: "Terminal logical test interface; Special conformance testing functions".
- [5] 3GPP TS 34.123-1: "User Equipment (UE) conformance specification; Part 1: Protocol conformance specification".
- [6] 3GPP TS 34.123-2: "User Equipment (UE) conformance specification; Part 2: Implementation Conformance Statement (ICS) proforma specification".

- [7] 3GPP TS 34.123-3: "User Equipment (UE) conformance specification; Part 3: Abstract Test Suite (ATS)".
- [8] 3GPP TS 34.108: "Common test environments for User Equipment (UE) conformance testing".
- [9] 3GPP TS 34.109: "Terminal logical test interface; Special conformance testing functions".
- [10] 3GPP TS 51.010-1: "Mobile Station (MS) conformance specification; Part 1: Conformance Specification".
- [11] 3GPP TS 51.010-2: "Mobile Station (MS) conformance specification; Part 2: Protocol Implementation Conformance Statement (PICS) proforma specification".
- [12] 3GPP TS 51.010-5: "Mobile Station (MS) conformance specification; Part 5: Inter-RAT (GERAN to UTRAN) Abstract Test Suite (ATS)".
- [13] ETSI ES 201 873-1: "Methods for Testing and Specification (MTS); The Tree and Tabular Combined Notation version 3; Part 1: TTCN-3 Core Language".
- [14] 3GPP TS 36.304: "Evolved Universal Terrestrial Radio Access (E-UTRA); "UE Procedures in Idle Mode".
- [15] 3GPP TS 36.306 "Evolved Universal Terrestrial Radio Access (E-UTRA); "UE Radio Access Capabilities".
- [16] 3GPP TS 36.321: "Evolved Universal Terrestrial Radio Access (E-UTRA); "Medium Access Control (MAC) protocol specification".
- [17] 3GPP TS 36.322: "Evolved Universal Terrestrial Radio Access (E-UTRA); "Radio Link Control (RLC) protocol specification".
- [18] 3GPP TS 36.323: "Evolved Universal Terrestrial Radio Access (E-UTRA); "Packet Data Convergence Protocol (PDCP) Specification".
- [19] 3GPP TS 36.331: "Evolved Universal Terrestrial Radio Access (E-UTRA) Radio Resource Control (RRC); Protocol Specification".
- [20] 3GPP TS 24.008: "Mobile Radio Interface Layer 3 specification; Core Network Protocols; Stage 3".
- [21] 3GPP TS 24.301: "Non-Access-Stratum (NAS) Protocol for Evolved Packet System (EPS); Stage 3".
- [22] 3GPP TS 24.303: "Mobility Management based on DSMIPv6; User Equipment (UE) to network protocols; Stage 3".
- [23] 3GPP TS 24.304: "Mobility management based on Mobile IPv4; User Equipment (UE) - foreign agent interface; Stage 3".
- [24] 3GPP TS 33.401: "3GPP System Architecture Evolution (SAE); Security architecture".
- [25] 3GPP TS 33.402: "3GPP System Architecture Evolution (SAE); Security aspects of non-3GPP accesses".
- [26] 3GPP TR 21.905: "Vocabulary for 3GPP Specifications".
- [27] ETSI ES 201 873-4: "Methods for Testing and Specification (MTS); The Testing and Test Control Notation version 3; Part 4: TTCN-3 Operational Semantics".
- [28] ETSI ES 201 873-5: "Methods for Testing and Specification (MTS); The Testing and Test Control Notation version 3; Part 5: TTCN-3 Runtime Interface (TRI)".
- [29] ETSI ES 201 873-6: "Methods for Testing and Specification (MTS); The Testing and Test Control Notation version 3; Part 6: TTCN-3 Control Interface (TCI)".
- [30] 3GPP TS 36.213: "Evolved Universal Terrestrial Radio Access (E-UTRA); Physical layer procedures".

- [31] 3GPP TS 27.005: "Use of Data Terminal Equipment - Data Circuit terminating Equipment (DTE-DCE) interface for Short Message Service (SMS) and Cell Broadcast Service (CBS)".
- [32] 3GPP TS 27.007: "AT command set for 3G User Equipment (UE)".
- [33] 3GPP TS 27.060: "Packet domain; Mobile Station (MS) supporting Packet Switched services".
- [34] 3GPP TS 36.101: "Evolved Universal Terrestrial Radio Access (E-UTRA); User Equipment (UE) radio transmission and reception".
- [35] 3GPP TS 36.211: "Evolved Universal Terrestrial Radio Access (E-UTRA); Physical channels and modulation".
- [36] 3GPP TS 25.331: "RRC Protocol Specification".
- [37] 3GPP TS 36.133: "Evolved Universal Terrestrial Radio Access (E-UTRA); Requirements for support of radio resource management".
- [38] 3GPP2 TSG-C C.S0024\_C v2.0: "cdma2000 High Rate Packet Data Air Interface Specification".
- [39] 3GPP2 TSG-C C.S0057-E v1.0: "Band Class Specification for cdma2000 Spread Spectrum Systems".
- [40] 3GPP TS 34.229-1: "Internet Protocol (IP) multimedia call control protocol based on Session Initiation Protocol (SIP) and Session Description Protocol (SDP); User Equipment (UE) conformance specification; Part 1: Protocol conformance specification".
- [41] 3GPP TS 33.203: "3G security; Access security for IP-based services".
- [42] 3GPP TS 24.229: "IP Multimedia Call Control Protocol based on Session Initiation Protocol (SIP) and Session Description Protocol (SDP); Stage 3".
- [43] IETF RFC 3320: "Signalling Compression (SigComp)".
- [44] IETF RFC 3485: "The Session Initiation Protocol (SIP) and Session Description Protocol (SDP) Static Dictionary for Signalling Compression (SigComp)".
- [45] IETF RFC 3486: "Compressing the Session Initiation Protocol (SIP)".
- [46] IETF RFC 4896: "Signalling Compression (SigComp) Corrections and Clarifications".
- [47] IETF RFC 5049: "Applying Signalling Compression (SigComp) to the Session Initiation Protocol (SIP)".
- [48] 3GPP TS 23.003: "Numbering, addressing and identification".
- [49] 3GPP TS 23.060: "General Packet Radio Service (GPRS) Service description; Stage 2".
- [50] 3GPP TS 29.061: "Interworking between the Public Land Mobile Network (PLMN) supporting packet based services and Packet Data Networks (PDN)".
- [51] 3GPP TS 34.229-3: "Internet Protocol (IP) multimedia call control protocol based on Session Initiation Protocol (SIP) and Session Description Protocol (SDP); User Equipment (UE) conformance specification; Part 3: Abstract Test Suite".
- [52] 3GPP TS 37.571-4: "User Equipment (UE) conformance specification for UE positioning; Part 4: Test Suites".
- [53] 3GPP TS 36.214: "Evolved Universal Terrestrial Radio Access (E-UTRA); Physical layer; Measurements".
- [54] IETF RFC 1144: "Compressing TCP/IP headers for low-speed serial links".
- [55] IETF RFC 2507: "IP Header Compression".
- [56] ITU-T Recommendation V.42bis: "Data compression procedures for data circuit-terminating equipment (DCE) using error correction procedures".

[57] ITU-T Recommendation V.44: "Data compression procedures".

## 3 Definitions and abbreviations

### 3.1 Definitions

For the purposes of the present document, the terms and definitions given in TR 21.905 [26] apply.

### 3.2 Abbreviations

For the purposes of the present document, the abbreviations given in TR 21.905 [26] apply.

## 4 E-UTRAN/SAE system architecture and test models

### 4.1 Test system architecture

#### 4.1.1 General system architecture

The general system architecture is shown in figure 4.1.1-1.

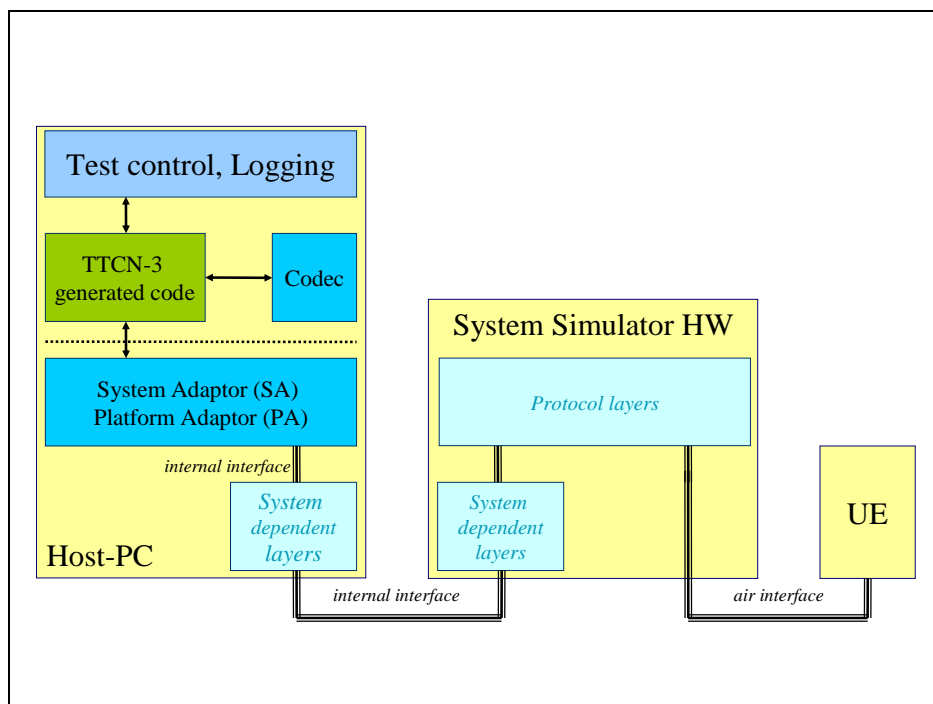

Figure 4.1.1-1: Architecture of system simulator

The scope of the present document is the TTCN-3 implementation of conformance tests. Specifications and definitions of the present document affect the codec and the system adaptor (SA). Test control and logging are out of scope as well as the interface between the TTCN-3 generated code and the system adaptor which can be either standardised TRI or proprietary.

The main assumptions regarding the system architecture are:

- TTCN-3 code runs on the host system only:
  - No TTCN-3 components are downloaded to system simulator HW.
  - Layer 2 tests (MAC, RLC) are controlled by appropriate configuration primitives in TTCN-3 but neither layer 2 nor parts of it are implemented in TTCN-3; the system simulator performs low layer procedure autonomously but all system simulator implementations shall result in the same test pattern at the air interface.
- Proprietary interfaces e.g. instead of the TRI are not considered in the test model.
- The timing considerations of the conformance tests shall be supported by appropriate timing information (e.g. system frame number) provided from/to the system simulator rather than by timing measurements in TTCN-3.

## 4.1.2 Component architecture

For E-UTRAN conformance tests each access technology (RAT) is hosted by a separate TTCN-3 parallel component (PTC):

- E-UTRAN.
- UTRAN.
- GERAN.
- Other technologies like 3GPP2 UTRAN.

The PTCs are controlled by the TTCN-3 master test component (MTC) which:

- is independent from the RAT;
- may host the upper tester for MMI and AT commands;
- creates, synchronises and terminates the PTCs;
- starts and terminates test cases.

Figure 4.1.2-1 shows this component architecture for a E-UTRAN and UTRAN scenario.

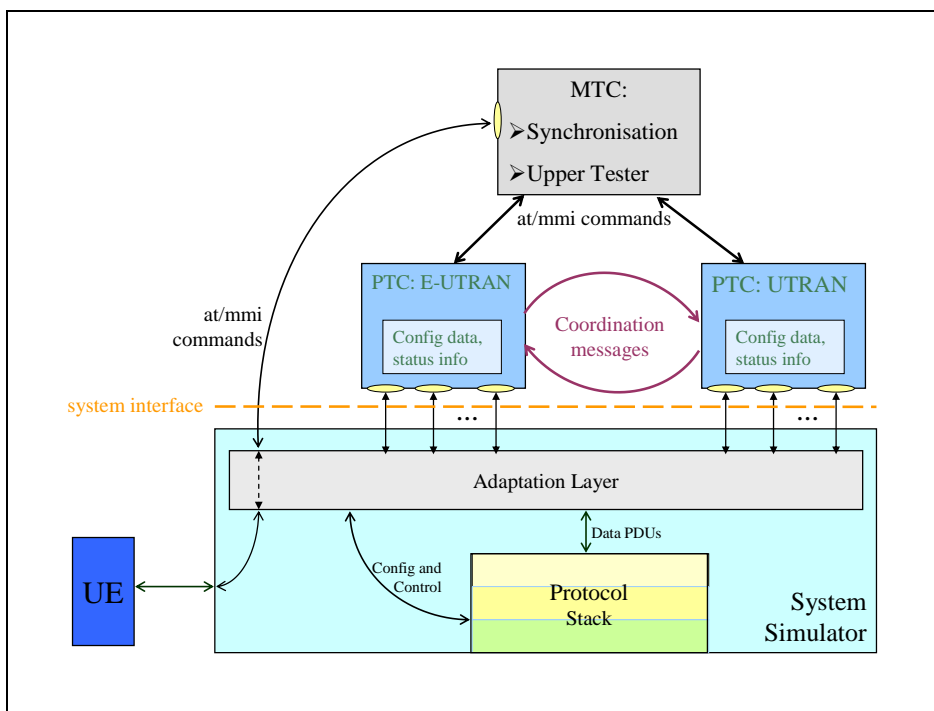

Figure 4.1.2-1: E-UTRAN-UTRAN component model

According to this model there are different interfaces to be considered:

MTC - PTC:

- common synchronisation of PTCs;
- upper tester primitives.

MTC - System Interface:

- upper tester primitives.

PTC - PTC:

- primitives containing information for IRAT handover.

PTC - System Interface:

- primitives containing peer-to-peer message;
- configuration primitives.

## 4.2 E-UTRAN test models

### 4.2.1 Layer 2 test models

When test loop mode is used for the Layer 2 tests the DRB ports at the SS side is referred to the raw DRB ones. At the SS side, DRBs are initially configured with default modes and parameters. For the purpose of L2-testing the DRBs may be reconfigured later on as indicated in the subsequent test models (see below).



## 4.2.1.1 MAC test model

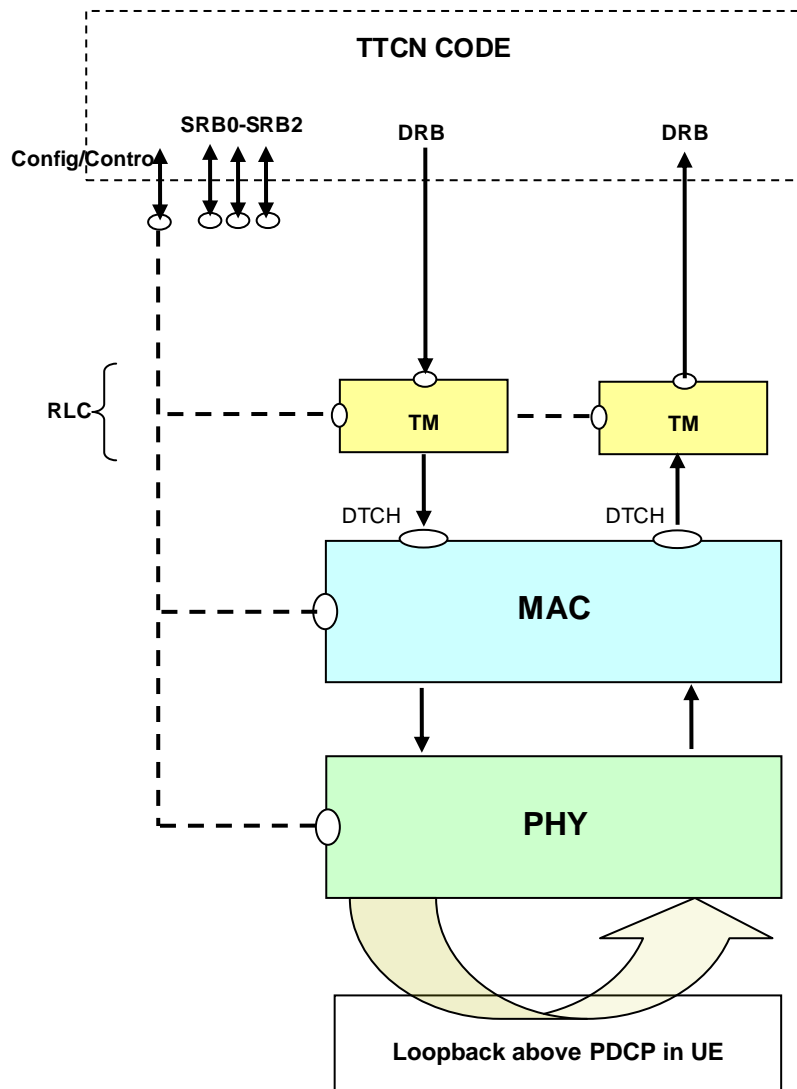

Figure 4.2.1.1-1: Test model for MAC testing

The UE is configured in Test Loop Mode, to loop back the user domain data above PDCP layer. On UE side Ciphering is enabled (since Mandatory) but with dummy ciphering algorithm, which is equivalent to not using ciphering. ROHC is not configured on UE Side.

On the SS Side, Layer 1 is configured in the normal way. MAC is configured in a special mode, where it does not add any MAC headers in DL and /or not remove any MAC headers in UL directions respectively at DRB port. In this case, the TTCN shall provide the final PDU, including padding. Except for this, the MAC layer shall perform all of its other functions.

On DRBs the RLC is configured in transparent mode. Hence with this configuration PDU's out of SS RLC are same as the SDU's in it. There is no PDCP configured on SS Side. The ports are directly above RLC.

There are two different test modes in which MAC header addition/removal can be configured:

DL/UL header-transparent mode: no header addition in DL and no header removal in UL.

DL only header-transparent mode: no header addition in DL; UL MAC is configured in normal mode to remove MAC header and dispatch the MAC SDUs according to the logical channel Ids.

If SS MAC is configured in DL/UL header-transparent mode, the PDU's exchanged at the DRB port between TTCN and SS, shall be the final MAC PDU's consisting of MAC, RLC and PDCP headers. TTCN code shall take care in DL

of building MAC header, RLC headers and PDCP headers and in UL handle MAC, RLC and PDCP headers. TTCN code shall take care of maintaining sequence numbers and state variables for RLC and PDCP layers. During testing of multiple DRBs at the UE side, it shall still be possible to configure only one DRB on SS side with configuration in the figure 4.2.1.1-1. Other DRBs will not be configured, to facilitate routing UL TBs. Multiplexing/de-multiplexing of PDUs meant/from different DRBs shall be performed in TTCN. Since the MAC layer does not evaluate the MAC headers in UL it cannot distinguish between SRB and DRB data in UL. Therefore there shall be no SRB traffic while MAC is configured in this test mode.

If SS MAC is configured in DL only header-transparent mode, the UL PDUs exchanged at the DRB port between TTCN and SS, shall be final RLC PDUs consisting of RLC and PDCP headers. SS shall route these PDUs based on logical channel IDs. In DL, TTCN sends fully encoded MAC PDUs at the DRB port (consisting of MAC, RLC and PDCP headers). In this case TTCN needs to take care of maintaining sequence numbers and state variables for RLC and PDCP layers. Furthermore in UL and DL the SS MAC layer shall be capable of dealing with SRB data (i.e. it shall handle DL RLC PDUs coming from SRBs RLC layer or dispatch UL RLC PDUs to SRBs) as in normal mode.

NOTE: TTCN shall ensure that no DL MAC SDUs in normal mode and DL MAC PDUs in test mode are mixed for the same TTI.

The UL Scheduling Grant and DL Scheduling assignments are configured from TTCN over system control port. SS reports PUCCH scheduling information reception over system indication port, if configured. In a similar way the reception of RACH preambles is reported by SS over the same port.

4.2.1.2 RLC test model

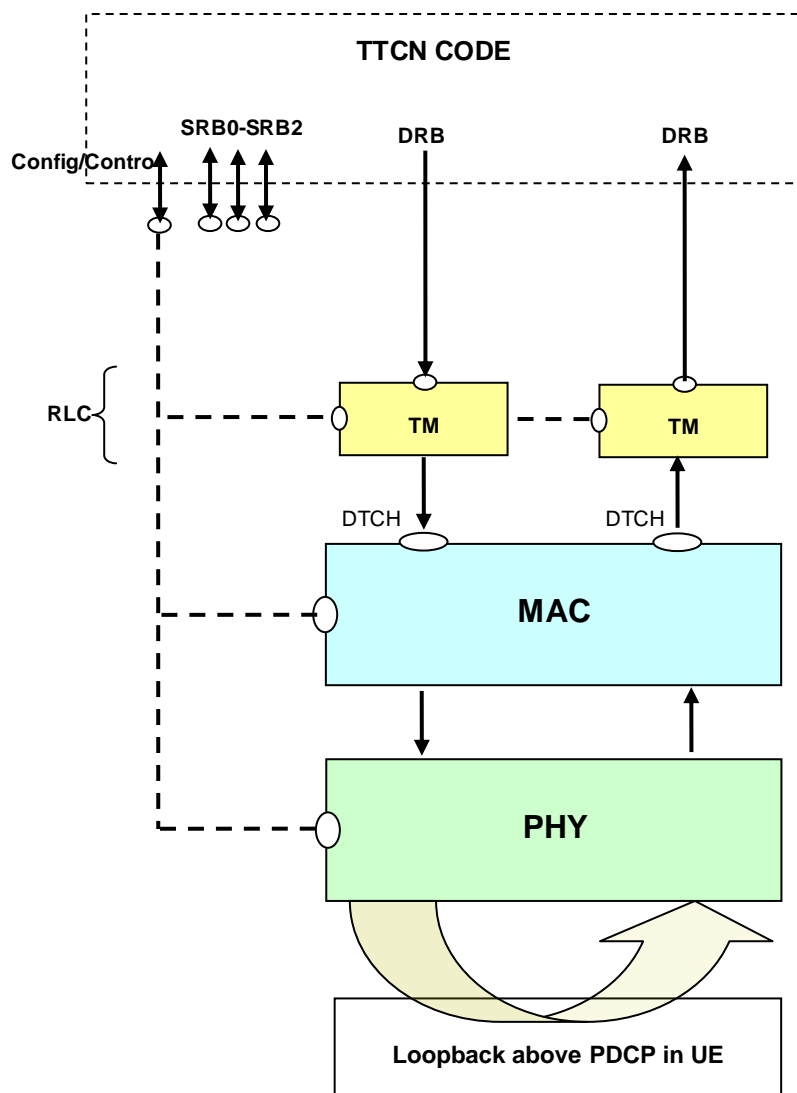

Figure 4.2.1.2.3-1: Test model for RLC AM/UM testing

This model is suitable for testing both UM/AM mode of operation of DRBs on UE side.

The UE is configured in Test Loop Mode, to loop back the user domain data above PDCP layer. On UE side Ciphering is enabled (since mandatory) but with dummy ciphering algorithm, which is equivalent to not using ciphering. ROHC is not configured on UE Side.

On the SS Side, L1 and MAC are configured in the normal way. The RLC is configured in transparent mode. Hence with this configuration PDUs out of SS RLC are same as the SDUs in it. There is no PDCP configured on SS Side. The ports are directly above RLC.

The PDUs exchanged between TTCN and SS, shall be the final RLC PDUs consisting of RLC and PDCP headers. TTCN code shall take care in DL of building RLC headers and PDCP headers and in UL handle RLC and PDCP headers. TTCN code shall take care of maintaining sequence numbers and state variables for RLC and PDCP layers. If RLC on UE side is in AM mode, TTCN shall take care of generating polls in DL and responding with RLC control PDUs on reception of UL Poll.

The UL Scheduling Grant and DL Scheduling assignments are configured from TTCN over system control port.

### 4.2.1.3 PDCP test model

#### 4.2.1.3.1 PDCP ROHC test model

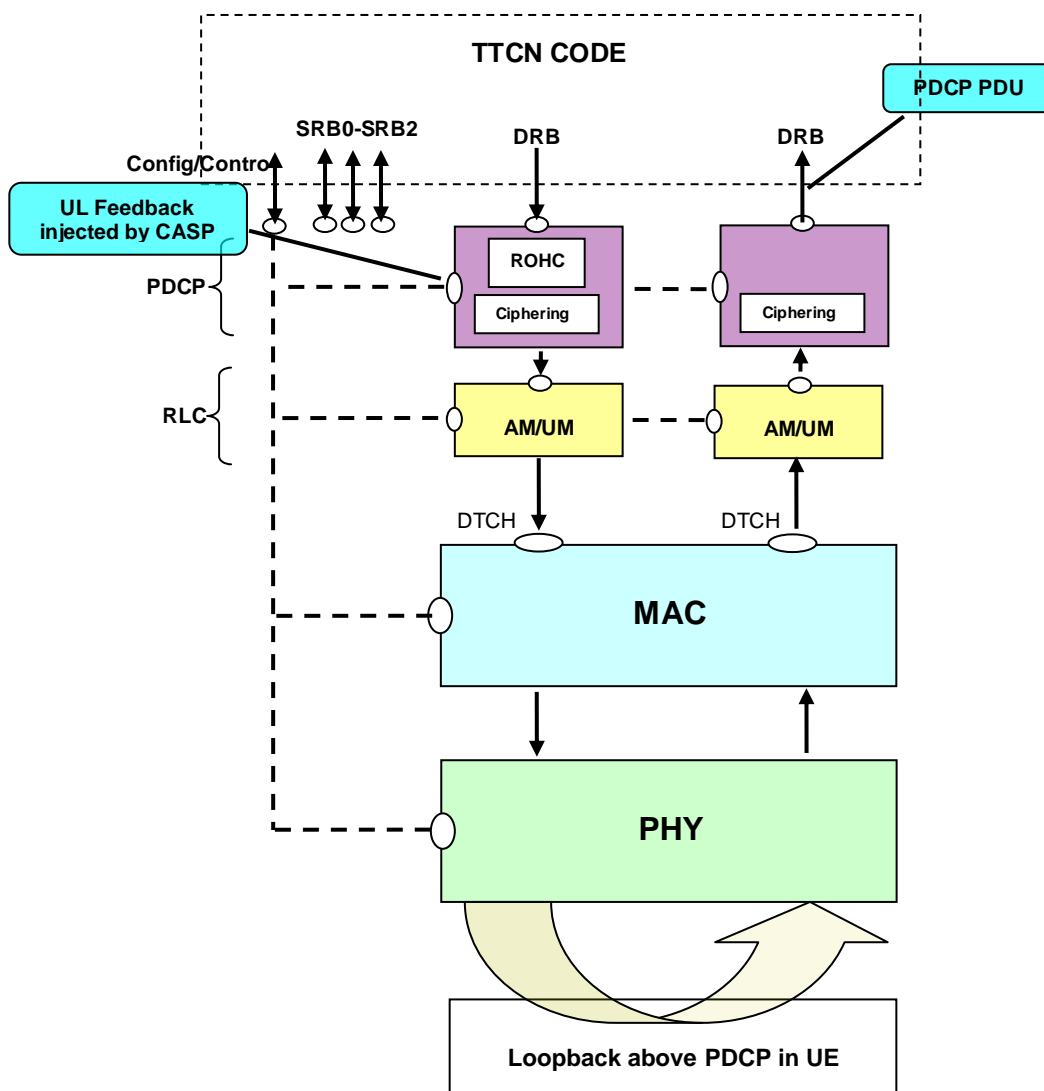

Figure 4.2.1.3.1-1: Test model for PDCP ROHC testing

The UE is configured in Test Loop Mode, to loop back the user domain data above PDCP layer. On UE side Ciphering is enabled and ROHC is configured.

On the SS Side L1, MAC and RLC are configured in normal way. They shall perform all of their functions. The ports are above PDCP.

The PDCP is configured in special mode, with no header manipulation. Ciphering is configured in both directions. ROHC is configured in DL direction only. UL ROHC feedback can be injected by control ASP. It shall be possible to configure 'no header manipulation' mode independently in UL and DL directions. When configured in special mode, SS shall not add PDCP header (DL) and remove PDCP Header (UL). PDCP state variables shall be maintained by SS PDCP layer. It shall be possible for SS PDCP to update state variables based on the PDU's in both directions, even though headers are not added/removed. Also, it shall be possible to read or set the PDCP internal state variables, by control primitives.

The UL Scheduling Grant and DL Scheduling assignments are configured from TTCN over system control port. SS reports PUCCH scheduling information reception over system indication port, if configured.

4.2.1.3.2 PDCP test model (Non ROHC)

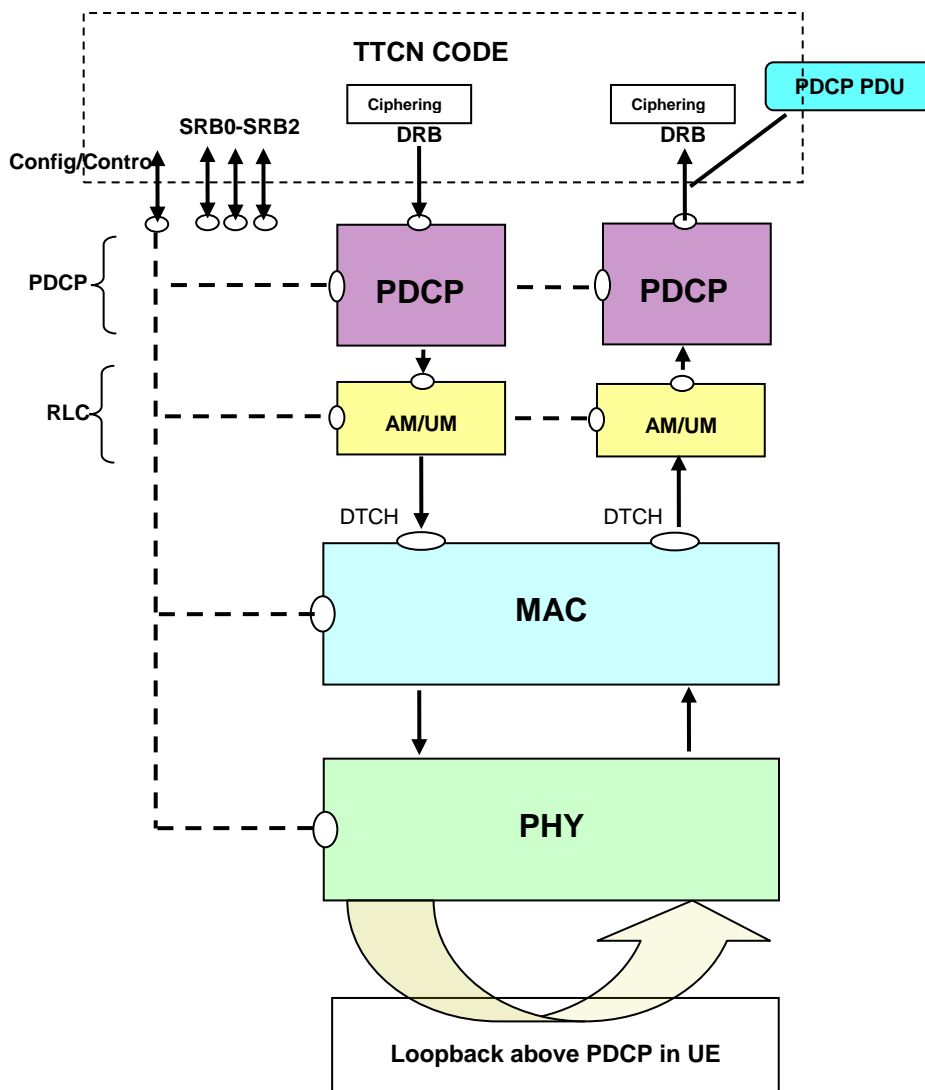

Figure 4.2.1.3.2-1: Test model for PDCP (Non ROHC) testing

The UE is configured in Test Loop Mode, to loop back the user domain data above PDCP layer. On UE side Ciphering is enabled and ROHC is not configured.

On the SS Side L1, MAC and RLC are configured in normal way. They shall perform all of their functions. The ports are above PDCP.

The PDCP is configured in a special mode, named transparent mode. In this mode, SS shall not add PDCP header (DL) and remove PDCP Header (UL). The TTCN maintains sequence numbers and state variables for the PDCP layer. The TTCN makes use of the AS ciphering functionality in both directions, employing the dummy ciphering algorithm. Ciphering/deciphering are performed using TTCN external functions. ROHC is not configured.

The UL Scheduling Grant and DL Scheduling assignments are configured from TTCN over system control port. SS reports PUCCH scheduling information reception over system indication port, if configured.

### 4.2.2 RRC test model

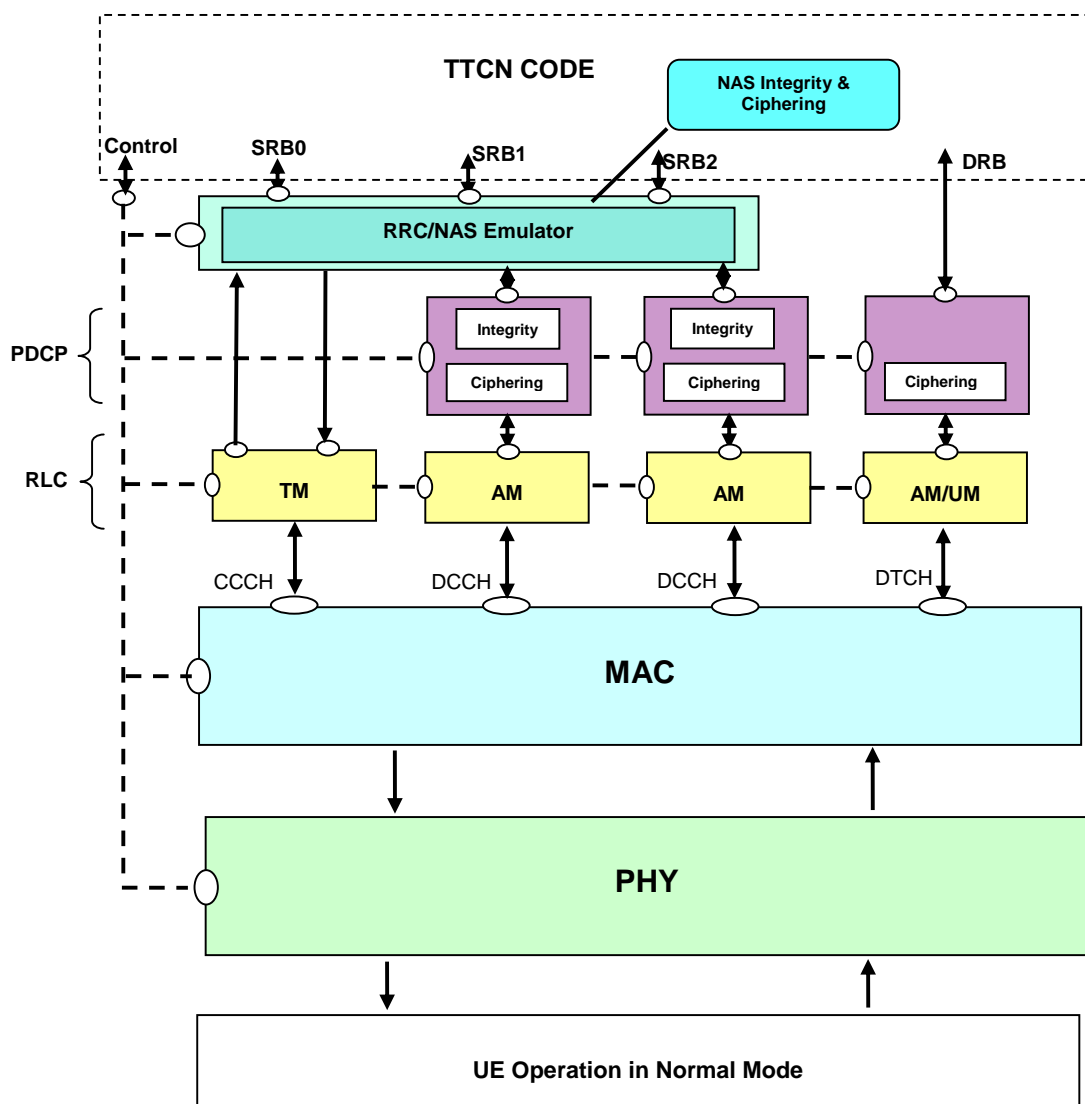

Figure 4.2.2-1: Test model for RRC testing

The UE is configured in normal mode. On UE side Ciphering/Integrity (PDCP and NAS) is enabled and ROHC is not configured.

On the SS Side L1, MAC, RLC and PDCP are configured in normal way. They shall perform all of their functions. For SRB0 the DL and UL port is above RLC. For SRB1 and SRB2 the port is above/below the RRC and NAS emulator,

which may be implemented as a parallel test component. For DRB, the port is above PDCP. PDCP Ciphering/Integrity is enabled. NAS integrity/Ciphering is enabled.

The RRC/NAS emulator for SRB1 and SRB2 shall provide the Ciphering and integrity functionality for the NAS messages. In UL direction, SS shall report RRC messages, still containing (where appropriate) the secure and encoded NAS message, to the RRC port. In DL, RRC and NAS messages with same timing information shall be embedded in one PDU after integrity and ciphering for NAS messages.

The UL Scheduling Grant and DL Scheduling assignments are configured from TTCN over system control port. SS reports PUCCH scheduling information reception over system indication port, if configured.

### 4.2.3 DRB test model

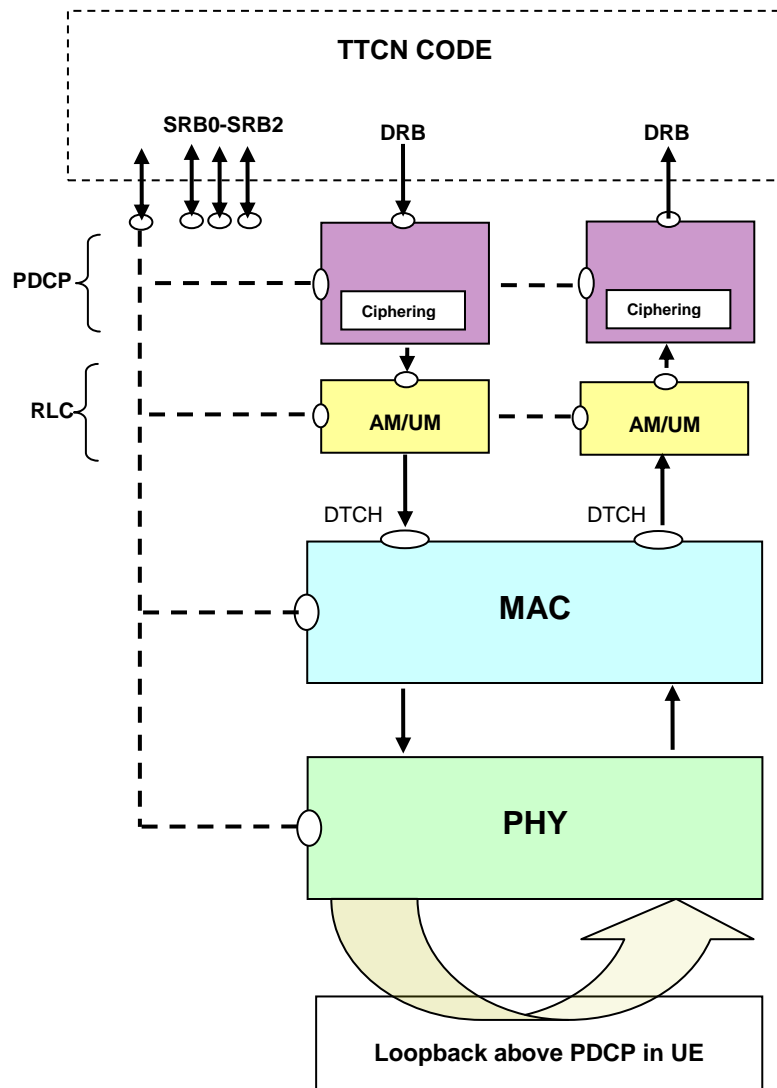

Figure 4.2.3-1: Test model for DRB testing

The UE is configured in Test Loop Mode, to loop back the user domain data above PDCP layer. Ciphering is optionally configured on UE side. In TTCN the DRB data is considered as raw data and there is no IP handling while the UE is in loopback mode.

On the SS Side L1, MAC, RLC and PDCP are configured in normal way. They shall perform all of their functions. The ports are above PDCP. When test loop mode is used for the DRB, the ports at the SS side refer to the raw DRB ones. Ciphering is enabled and ROHC is not configured on SS Side.

SS shall send in DL all PDU's received from different RB's but with same timing control information in one MAC PDU and in one TTI.

The UL Scheduling Grant and DL Scheduling assignments are configured from TTCN over system control port. SS reports PUCCH scheduling information reception over system indication port, if configured.

## 4.2.4 IP Test Model

Depending on different test scenarios user plane data can be distinguished in:

- Raw user data upon EUTRA PDCP (Raw mode);
- IP user data (IP mode).

The raw user data are applied for L2 or DRB tests, no IP protocols are involved. The UL user data is directly routed to the EUTRA\_PTC.

The IP user data are applied when IP packets data are handled in TTCN. A DRB can have one or more Transport and Internet protocols configured.

Whether a DRB is in IP or in raw mode depends on the configuration of the routing table in the DRB-Mux. This is controlled by the IP\_CTRL port and independent from the configuration of the IP connections (IP\_SOCKET).

### 4.2.4.1 IP user data

To allow the usage of common protocol implementations at the system adaptor the related interfaces in TTCN-3 are based on the Sockets API.

There can be one or several sockets (server or client) for each DRB: TCP, UDP and ICMP.

Each socket can be clearly identified by the IP address, port number and the protocol (tcp|udp|icmp). It implies that a TCP socket can be either server or client.

It is assumed that:

- Different DRBs are not using the same sockets.
- The UE behaviour of a single IP-based protocol on a specific socket like DHCP can be included in conformance tests.
- Other protocols like ESP are not considered but can easily be introduced later, if necessary, by using the same socket approach.

The routing of IP packets from the IP stack to the DRBs in DL and from the DRBs either to the DRB port (E\_DRB in case of EUTRA) or to the IP stack in UL is done by the DRB-Mux. This behaviour is controlled by the DRB-Mux's routing table.

The general architecture of the IP test model is shown in figure 4.2.4.1-1 (with a DHCP server as example for IP handling).

**NOTE:** In figure 4.2.4.1-1 DHCP is one example for a protocol above the IP stack; other protocols like DNS can also be implemented but this a pure TTCN implementation issue and independent from the system interface.

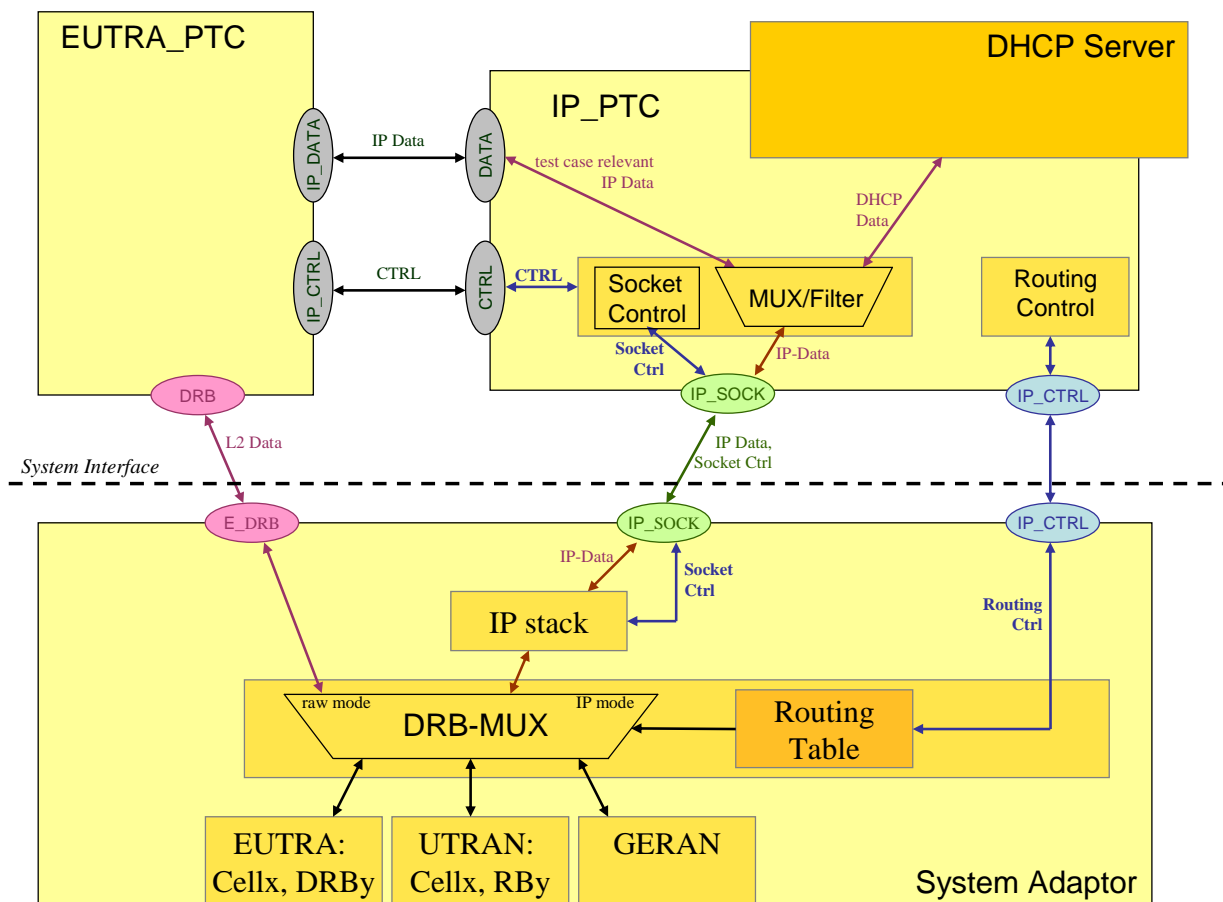

Figure 4.2.4.1-1: Example of EUTRA IP test model with a DHCP server

#### 4.2.4.2 Configuration of Sockets

The following configurations are controlled by the IP\_PTC (IP\_SOCKET\_REQ). The socket configuration and the sending/receiving of data are done with the same ASP on the system port IP\_SOCK.

##### 4.2.4.2.1 Socket Establishment

TCP server

TCP socket configured as server: the socket 'listens' to a 'connect' from the UE. The socket can be configured by using the following system calls of the Berkeley Sockets API:

- socket (AF\_INET | AF\_INET6, SOCK\_STREAM, 0);
- setsockopt;
- bind (local IP address Port);
- listen.

NOTE: Currently the only socket option being defined is SO\_BROADCAST

When the UE connects to the server the connection is accepted with the 'accept' system call.



## TCP client

A TCP connection is established to an existing TCP server at the UE side. This can be done with the following system calls:

- socket (AF\_INET|AF\_INET6, SOCK\_STREAM, 0);
- setsockopt;
- connect (remote Server Addr of the UE = IP-Addr + Port).

## UDP socket

A UDP socket can be established with the system calls

- socket (AF\_INET|AF\_INET6, SOCK\_DGRAM, 0);
- setsockopt;
- bind (local IP address, Port);
- connect.

NOTE 1: 'setsockopt' can be used to set the option SO\_BROADCAST to allow broadcast messages (e.g. for DHCP).

NOTE 2: Usage of 'connect' depends on implementation of the system adaptor.

### 4.2.4.2.2 Socket Release

A socket is released:

- in case of TCP when the remote entity closes the connection;
- when it is closed explicitly by the IP\_PTC (system call 'close').

NOTE: In general the sockets are independent from the configuration of the DRBs. Especially in case of UDP or ICMP the sockets can exist even without any DRB being configured.

### 4.2.4.3 Handling of IP data

Sending and receiving of IP data is done by the same ASPs as the socket establishment on IP\_SOCKET. In TTCN the IP data are handled by a separate TTCN component: IP\_PTC. This PTC can deal with the data according to the respective protocol, e.g. DHCP. In general, this is out of scope for the (signalling conformance) test case in terms of pass/fail assignment.

The IP\_PTC will receive data from sockets being configured for the corresponding IP protocols. Any unrecognised IP packets are discarded by the IP stack in the system adaptor.

When the IP data is relevant for the test purpose, e.g. the test purpose is to test DHCP, the IP data are routed to the EUTRA\_PTC. This allows generic protocol implementations for the common case, i.e. IP\_PTC and DHCP server are independent from test case specific implementations.

The interface between EUTRA\_PTC and IP\_PTC is a pure TTCN implementation issue and independent of the system interface. Furthermore it is irrelevant for the system interface whether e.g. the DHCP server is part of the IP\_PTC or implemented as a separate PTC.

- For TCP, the primitives to send and receive data correspond to the 'send' and 'recv' system calls.
- For UDP and ICMP, the primitives correspond to the 'sendto' and 'recvfrom' system calls.
- For both UDP and TCP the system adaptor may send ("in-band") error indications in case of system errors. That results in an assignment of inconc by the IP\_PTC.

#### 4.2.4.4 Routing of IP Data

The routing of IP data is done in the DRB-Mux which gets a routing table configured. This table associates the address and protocol information of IP packets (protocol, local IP address, local port, remote IP address, remote port) with the radio bearer (RAT, cell, DRB id).

In UL a DRB is considered being in raw mode when there is no entry found in the routing table. It is considered being in IP mode when there is any entry regardless of the protocol and address information being stored, i.e. in UL, the SS does not need to evaluate the IP header to route the data (in raw mode this would cause problems in the case of loopback data).

In DL the IP packets of the IP stack are routed to the DRBs acc. to the routing information in the routing table (see annex D for details).

**NOTE:** Only the IP PTC can re-configure the Routing Table; if that needs to be triggered by a RAT specific PTC, this is done by appropriate coordination messages but the RAT specific PTCs don't have a direct access to the routing tables.

#### 4.2.4.5 Multiple PDNs

In case multiple PDNs broadcast, or multicast datagrams sent by the UE, need to assigned to the respective PDN:

##### IPv4

When the UE does not get a valid IPv4 address assigned via NAS signalling it will request the IP address via DHCP. In this case there are DHCP broadcast messages in UL.

In the case of multiple PDNs, it cannot be distinguished by evaluating the IP address to which PDN the message belongs but additional information is necessary:

The network side needs to know which interface (i.e. network) the broadcast comes from; in case of LTE this is associated with the default bearer of the particular PDN.

**NOTE:** In principle the 'chaddr' field or the 'client identifier' option of the DHCP messages may be used to distinguish different interfaces (e.g. for Ethernet this would be the MAC address) but it is not specified how these fields are to be used by the UE (or how to configure them at the UE); RFCs (e.g. RFC 2131) only require the client identifier to be unique in a given subnet.

##### IPv6

The UE gets an interface identifier assigned via NAS signalling (TS 24.301 [21] clause 6.2.2) which is used as link-local address during stateless address auto configuration (TS 23.060 [43] clause 9.2.1.1 and TS 29.061 [44] clause 11.2):

The UE may send a ROUTER SOLICITATION message (multicast) to which the network responds with a ROUTER ADVERTISEMENT.

Since the ROUTER SOLICITATION message contains the interface identifier as assigned via NAS signalling, even in the case of multiple PDNs it can distinguished which PDN is concerned, as long as the interface identifiers are different for different PDNs (for UE side as well as for network side).

**NOTE:** According to TS 23.060 [43] clause 9.2.1.1 and RFC 3314 a real network (PDN-GW) itself shall send an (unsolicited) ROUTER ADVERTISEMENT after it has assigned the interface identifier.

#### Conclusions and Requirements:

In the case of broadcast or multicast messages TTCN needs additional information about the PDN being addressed.

When a socket connection is configured to allow broadcasts and there is a broadcast or multicast message in UL the SS shall provide information about on which bearer the datagram has been sent (RAT, cell, DRB id).

**NOTE:** From the socket programming point of view multiple PDNs for the SS are like a multi-homed host: Servers for different interfaces are bound to different interfaces (e.g. using the 'bind' system call with a specific IP address instead of IPADDR\_ANY) or a server may retrieve the interface id for a received datagram from the IP stack with an appropriate system call.

Even though the details are implementation dependent, the SS shall be capable of:

determining RAT, cell, DRB id for any broadcast or multicast datagram in UL

avoiding any duplication of messages in UL even when multiple servers are listening to broadcast/multicast messages (what is a possible SS implementation)

#### 4.2.4.6 IP Addresses Guidelines

##### 4.2.4.6.1 Common Structure of IP Addresses

IPv4:

Network prefix (subnet address)	n bits
Host part	32-n bits

with 'n' e.g. depending on the network class

IPv6:

Network prefix	
Global routing prefix	64 – n bits
Subnet ID	n bits
Interface ID	64 bits

Addresses within one network (PDN) have all the same subnet address (IPv4) or global routing prefix (IPv6)

NOTE: As a consequence at the system simulator, routing can be done based on appropriate network masks, but that is dependent on SS implementation and therefore is out of scope for this document.

##### 4.2.4.6.2 Common Requirements regarding IP Addresses

IP addresses are configured via PIXIT parameters as defined in clause 9.1.

These PIXIT parameters shall fulfil the following requirements:

Network and UE addresses shall be different from each other

Network entities (DHCP server, DNS server, P-CSCF etc.) of a given PDN shall all have the same global routing prefix (IPv6) or subnet address (IPv4).

The IP address assigned to the UE shall have the same global routing prefix (IPv6) or subnet address (IPv4) as the corresponding network.

Requirements for IPv6: according to TS 23.401, cl. 5.3.1.2.2

The 64 bit network prefix of a UE's IPv6 address is unique

The UE may change its interface id during auto configuration

The UE must use the given interface id in the link local address for router solicitation but may use any other interface id in the global address

NOTE: As a consequence, the SS implementation needs to cope with the changing of the UE address and cannot rely on static IP address assignment to the UE.

Global routing prefix (IPv6) and subnet address (IPv4) shall be different for different PDNs

Home agent address:

The home agent is located in the UE's home network (which shall be considered to find an appropriate network prefix for the home agent's IP address)

In order to simplify implementations, the following rules shall be applied:

The IPv6 interface identifier as assigned to the UE via NAS signalling shall be unique, i.e.

It shall be different for different PDNs

It shall differ from the interface ids of the other entities on the link (in general the interface id of the PDN-GW)

Multiple PDNs shall have different IPv6 interface identifier for the PDN-GW

NOTE: Consistency checks for addresses of different PDNs can be done based on an appropriate network mask (IPv4, e.g. 255.255.255.0) and global routing prefix (IPv6, e.g. 2001:db8:1234::/48).

#### 4.2.4.7 User Plane Signalling for Address Allocation

For IPv4, the UE gets assigned the IP address via NAS signalling unless it explicitly requests to use DHCP.

For IPv6, the UE gets assigned a unique interface identifier to be used until it has successfully performed the auto-configuration procedure (Ref. to RFC 2462).

NOTE: This clause specifies behaviour of the SS (TTCN) to achieve successful IP signalling; but in general, IP signalling is out of scope for conformance tests as defined in TS 36.523-1 [1].

##### 4.2.4.7.1 DHCP

When the UE supports IPv4 and does not get an IPv4 address via NAS signalling it will request the address via DHCP (Ref. to RFC2131).

The UE may send a **DHCPDISCOVER** with or without Rapid Commit Option (Ref. to RFC 4039):

UE sends **DHCPDISCOVER** according to table 4.2.4.7.1-1 with Rapid Commit Option.

TTCN sends **DHCPACK** according to table 4.2.4.7.1-4

UE sends **DHCPDISCOVER** according to table 4.2.4.7.1-1 without Rapid Commit Option.

TTCN sends **DHCPOFFER** according to table 4.2.4.7.1-2

When the Rapid Commit option is not used the UE sends a **DHCPREQUEST** as response to the **DHCPOFFER**:

UE sends **DHCPREQUEST** according to table 4.2.4.7.1-3

TTCN sends **DHCPACK** according to table 4.2.4.7.1-4

Any other DHCP messages shall be ignored by TTCN.

Table 4.2.4.7.1-1: DHCPDISCOVER

UDP		
SRC ADDR	0.0.0.0	any address
SRC Port	68	not checked
DEST ADDR	255.255.255.255	broadcast
DEST Port	67	
DHCP		
op	'01'O	BOOTREQUEST
htype	any value	
hlen	any value	
hops	any value	
xid	any value	
secs	any value	
flags	any value	
ciaddr	any value	0 according to RFC 2131 Table 5
yiaddr	any value	0 according to RFC 2131 Table 5
siaddr	any value	0 according to RFC 2131 Table 5
giaddr	any value	0 according to RFC 2131 Table 5
chaddr	any value	client's hardware address
sname	any value	(may be overloaded with further options)
file	any value	(may be overloaded with further options)
options		NOTE
magic cookie	'63825363'O	
message type	'01'O	DHCPDISCOVER
rapid commit	present	shortened address assignment by 2-message exchange acc. to RFC 4039
	not present	address assignment by 4-message exchange

NOTE: Any further options are not evaluated and ignored by TTCN

Table 4.2.4.7.1-2: DHCPOFFER

UDP		
SRC ADDR	valid server address	address as configured by PIXIT
SRC Port	67	
DEST ADDR	255.255.255.255	broadcast
DEST Port	68	
DHCP		
op	'02'O	BOOTREPLY
htype	as in corresponding DHCPDISCOVER	NOTE 1
hlen	as in corresponding DHCPDISCOVER	NOTE 1
hops	'00'O	NOTE 2
xid	as in corresponding DHCPDISCOVER	NOTE 2
secs	'0000'O	NOTE 2
flags	as in corresponding DHCPDISCOVER	NOTE 2
ciaddr	'00000000'O	NOTE 2
yiaddr	valid UE address	address to be assigned to the UE (as configured by PIXIT)
siaddr	0	the UE does not need to retrieve any operating system executable image
giaddr	as in corresponding DHCPDISCOVER	NOTE 2
chaddr	as in corresponding DHCPDISCOVER	NOTE 2
sname	'000000000000000000'O	
file	'00000000000000000000000000000000'O	
options		
magic cookie	'63825363'O	
message type	'02'O	DHCPOFFER
lease time	86400	one day; mandatory (NOTE 2)
server identifier	server address	server address as used in the UDP header

NOTE 1: To get any valid value  
NOTE 2: According to table 3 in RFC 2131

Table 4.2.4.7.1-3: DHCPREQUEST

UDP		
SRC ADDR	0.0.0.0	any address
SRC Port	68	not checked
DEST ADDR	255.255.255.255	broadcast
DEST Port	67	
DHCP		
op	'01'O	BOOTREQUEST
htype	any value	
hlen	any value	
hops	any value	
xid	any value	
secs	any value	
flags	any value	
ciaddr	any value	0 according to RFC 2131 Table 5
yiaddr	any value	0 according to RFC 2131 Table 5
siaddr	any value	0 according to RFC 2131 Table 5
giaddr	any value	0 according to RFC 2131 Table 5
chaddr	any value	client's hardware address
sname	any value	(may be overloaded with further options)
file	any value	(may be overloaded with further options)
options		NOTE
magic cookie	'63825363'O	
message type	'02'O	DHCPREQUEST

NOTE: Any further options are not evaluated and ignored by TTCN

Table 4.2.4.7.1-4: DHCPACK

UDP		
SRC ADDR	valid server address	address as configured by PIXIT
SRC Port	67	not checked
DEST ADDR	255.255.255.255	broadcast
DEST Port	68	
DHCP		
op	'02'O	BOOTREPLY
htype	'01'O	
hlen	as in corresponding DHCPREQUEST or DHCPDISCOVER	NOTE
hops	'00'O	NOTE
xid	as in corresponding DHCPREQUEST or DHCPDISCOVER	NOTE
secs	'0000'O	NOTE
flags	as in corresponding DHCPREQUEST or DHCPDISCOVER	NOTE
ciaddr	'00000000'O	NOTE
yiaddr	valid UE address	address to be assigned to the UE (as configured by PIXIT)
siaddr	0	the UE does not need to retrieve any operating system executable image
giaddr	as in corresponding DHCPREQUEST or DHCPDISCOVER	NOTE
chaddr	as in corresponding DHCPREQUEST or DHCPDISCOVER	NOTE
sname	'0000000000000000'O	
file	'00000000000000000000000000000000'O	
options		
magic cookie	'63825363'O	
message type	'05'O	DHCPACK
lease time	86400	one day; mandatory (NOTE)
server identifier	server address	server address as used in the UDP header

NOTE: According to table 3 in RFC 2131

#### 4.2.4.7.2 DHCPv6

DHCPv6 is not needed for E-UTRA conformance tests as defined in 36.523-1[1]

#### 4.2.4.7.3 ICMPv6

When the UE supports IPv6 it will perform IPv6 Stateless Address Auto configuration according to RFC 4862. The UE sends an **ICMPv6 Router Solicitation** message according to table 4.2.4.7.3-1; as response the TTCN sends an **ICMPv6 Router Advertisement** message according to table 4.2.4.7.3-2.

NOTE: The TTCN does not send any (periodic) unsolicited Router Advertisement, i.e. the UE is expected to ask for an immediate advertisement whenever it is needed.

Any other ICMPv6 messages are ignored by the TTCN (especially in accordance to TS 23.060, clause 9.2.1.1, the TTCN silently discards Neighbour Solicitation).

**Table 4.2.4.7.3-1: ICMPv6 Router Solicitation**

IPv6		
SRC ADDR	link local address	NOTE 1
DEST ADDR	multicast address	NOTE 2
ICMPv6 (Ref. to RFC 4861)		
type	133	Router Solicitation
code	0	
checksum	not checked	
reserved	ignored	
options		
source link-layer address	ignored if present	
other options	ignored	
NOTE 1: The UE shall use the interface identifier as assigned via NAS signalling (but this is not checked in TTCN).		
NOTE 2: TTCN detects the multicast address by checking it to start with FF02 but accepts any of these addresses.		

Table 4.2.4.7.3-2: ICMPv6 Router Advertisement

IPv6		
SRC ADDR	link local address (NW)	NOTE 1
DEST ADDR	link local address (UE)	NOTE 2
ICMPv6 (Ref. to RFC 4861)		
type	134	Router Advertisement
code	0	
checksum	calculated by TTCN	
current hop limit	64	arbitrarily selected
m-flag	'0'B	no "Managed address configuration"; NOTE 3
o-flag	'0'B	no "Other configuration"
reserved	'000000'B	
router lifetime	65535	max. value
reachable time	0	unspecified
retrans timer	0	unspecified
options		
source link-layer address	not present	
mtu	not present	
prefix information		
type	'03'O	
length	4	
prefix length	64	/64 IPv6 prefix acc. to TS 23.401
on-link flag	'0'B	no "On-link detection"; NOTE 3
autonomous address configuration flag	'0'B	
reserved1	'000000'B	
valid lifetime	'FFFFFFFF'O	infinity; NOTE 3
preferred lifetime	'FFFFFFFF'O	infinity; NOTE 3
reserved2	'00000000'B	
prefix	globally unique /64 IPv6 prefix to be assigned to the UE	NOTE 4, 5
NOTE 1: The server's link local address is derived from the server's global IPv6 address (PIXIT parameter)		
NOTE 2: As received as SRC address of the corresponding Router Solicitation		
NOTE 3: Acc. to TS 29.062 clause 11.2.1.3.2		
NOTE 4: The routing prefix of the UE's global IPv6 address is derived from the respective PIXIT parameter		
NOTE 5: Since the UE may change its interface identifier after successful auto configuration to any value in general the IPv6 address used by the UE differs from the PIXIT		

#### 4.2.4.7.4 DNS

DNS is not needed for E-UTRA conformance tests as defined in 36.523-1[1].



## 4.2.4A LTE-Carrier Aggregation test Models

### 4.2.4A.1 CA-MAC test model

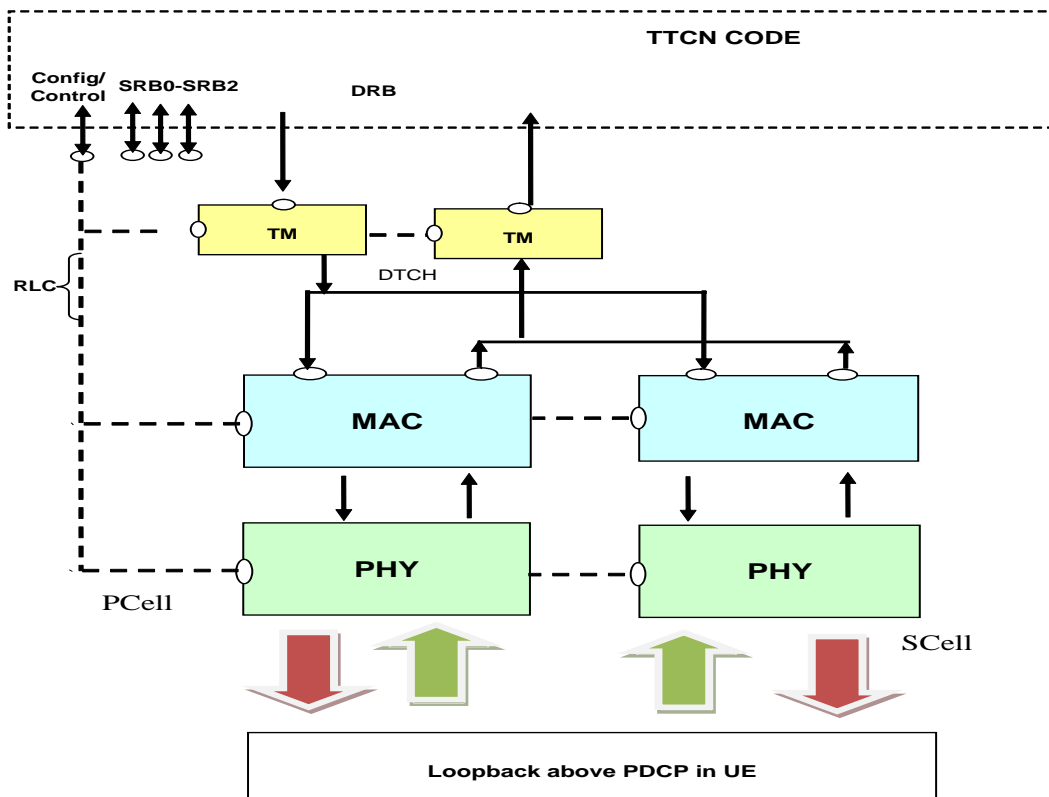

Figure 4.2.4A.1-1: Test model for CA-MAC testing

The UE is configured in Test Loop Mode, to loop back the user domain data above PDCP layer. On UE side Ciphering is enabled (since Mandatory) but with dummy ciphering algorithm, which is equivalent to not using ciphering. ROHC is not configured on UE Side.

On the SS Side,

Pcell only: On DRBs the RLC is configured in transparent mode. Hence with this configuration PDU's out of SS RLC are same as the SDU's in it. There is no PDCP configured on SS Side. The ports are directly above RLC.

Pcell/Scell: Layer 1 is configured in the normal way. MAC is configured in a special mode, where it does not add any MAC headers in DL and /or not remove any MAC headers in UL directions respectively at DRB port. In this case, the TTCN shall provide the final PDU, including padding. Except for this, the MAC layer shall perform all of its other functions. For SRB's/BCCH/PCCH the configuration is same as in CA-RRC test model.

There are two different test modes in which MAC header addition/removal can be configured:

DL/UL header-transparent mode: no header addition in DL and no header removal in UL.

DL only header-transparent mode: no header addition in DL; UL MAC is configured in normal mode to remove MAC header and dispatch the MAC SDUs according to the logical channel Ids.

If SS MAC is configured in DL/UL header-transparent mode, the PDU's exchanged at the DRB port between TTCN and SS, shall be the final MAC PDU's consisting of MAC, RLC and PDCP headers. TTCN code shall take care in DL of building MAC header, RLC headers and PDCP headers and in UL handle MAC, RLC and PDCP headers. TTCN code shall take care of maintaining sequence numbers and state variables for RLC and PDCP layers. During testing of multiple DRBs at the UE side, it shall still be possible to configure only one DRB on SS side with configuration in the

figure 4.2.4A.1-1. Other DRBs will not be configured, to facilitate routing UL TBs. Multiplexing/de-multiplexing of PDUs meant/from different DRBs shall be performed in TTCN. Since the MAC layer does not evaluate the MAC headers in UL it cannot distinguish between SRB and DRB data in UL. Therefore there shall be no SRB traffic while MAC is configured in this test mode.

If SS MAC is configured in DL only header-transparent mode, the UL PDUs exchanged at the DRB port between TTCN and SS, shall be final RLC PDUs consisting of RLC and PDCP headers. SS shall route these PDUs based on logical channel IDs. In DL, TTCN sends fully encoded MAC PDUs at the DRB port (consisting of MAC, RLC and PDCP headers). In this case TTCN needs to take care of maintaining sequence numbers and state variables for RLC and PDCP layers. Furthermore in UL and DL the SS MAC layer shall be capable of dealing with SRB data (i.e. it shall handle DL RLC PDUs coming from SRBs RLC layer or dispatch UL RLC PDUs to SRBs) as in normal mode.

NOTE: TTCN shall ensure that no DL MAC SDUs in normal mode and DL MAC PDUs in test mode are mixed for the same TTI.

The UL Scheduling Grant and DL Scheduling assignments are configured from TTCN over system control port. SS reports PUCCH scheduling information reception in Pcell over system indication port, if configured. In a similar way the reception of RACH preambles in Pcell is reported by SS over the same port.

### 4.2.4A.2 CA-RRC test model

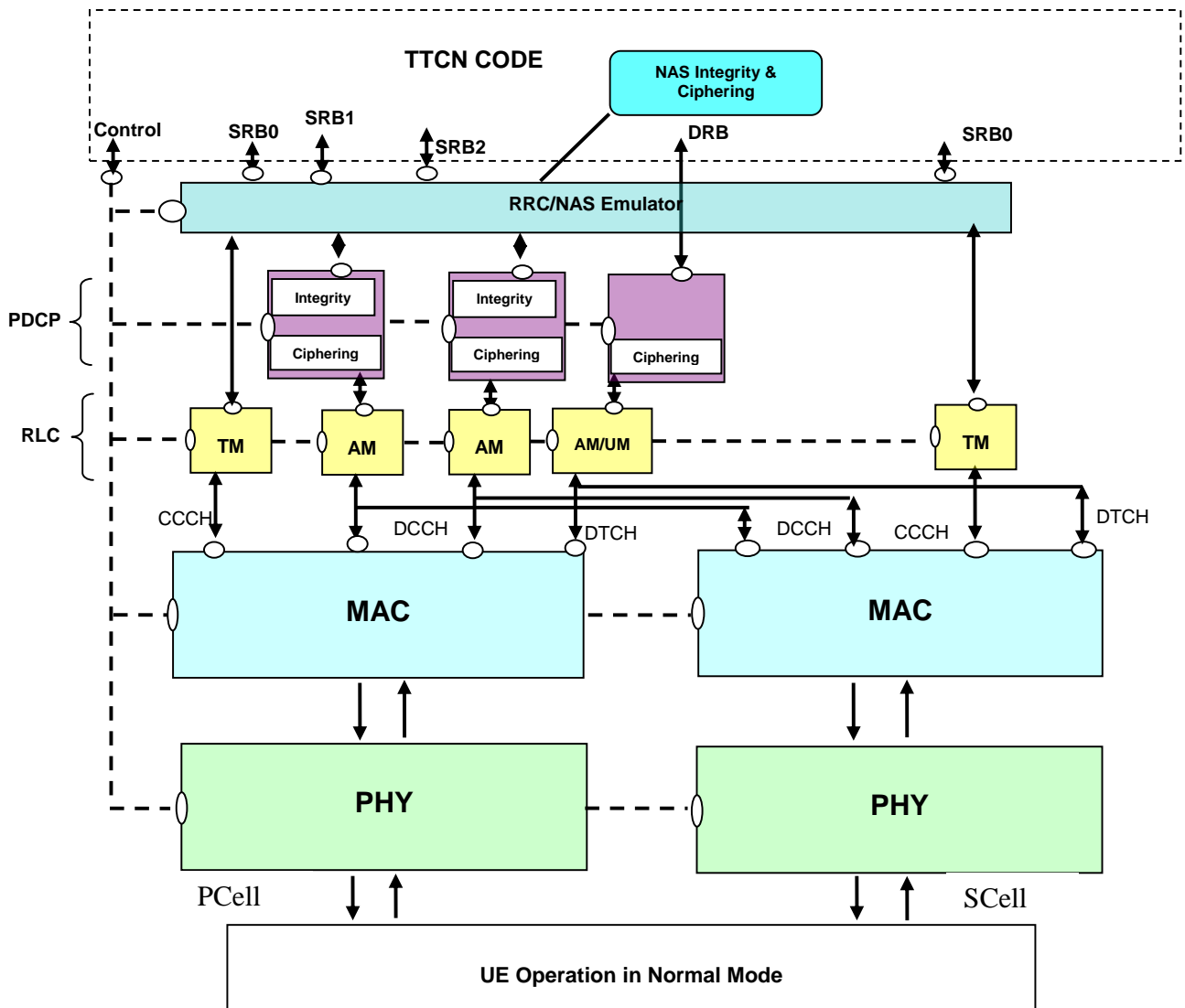

Figure 4.2.4A.2-1: Test model for CA-RRC testing

The UE is configured in normal mode. On UE side Ciphering/Integrity (PDCP and NAS) is enabled and ROHC is not configured.

On the SS Side L1 (Pcell/Scell), MAC (Pcell/Scell), RLC (Pcell) and PDCP (Pcell) are configured in normal way. They shall perform all of their functions. For SRB0 the DL and UL port is above RLC. For SRB1 and SRB2 the port is above/below the RRC and NAS emulator, which may be implemented as a parallel test component. For DRB, the port is above PDCP. PDCP Ciphering/Integrity is enabled. NAS integrity/Ciphering is enabled.

Note: RLC for BCCH/ PCCH/CCH are configured per serving cell; RLC and PDCP for DCCH/DTCH are configured only in Pcell and are additionally multiplexed on MAC of associated Scells.

The RRC/NAS emulator for SRB1 and SRB2 shall provide the Ciphering and integrity functionality for the NAS messages. In UL direction, SS shall report RRC messages, still containing (where appropriate) the secure and encoded NAS message, to the RRC port. In DL, RRC and NAS messages with same timing information shall be embedded in one PDU after integrity and ciphering for NAS messages.

The UL Scheduling Grant and DL Scheduling assignments are configured from TTCN over system control port. SS reports PUCCH scheduling information reception over system indication port, if configured.

## 4.2.5 IP model extension for IMS

The IMS test model is based on the IP Test Model with extensions to support IPsec. Support of Signalling Compression (SigComp) may be added in the future if needed.

IMS in general may use TCP, UDP or alternated TCP/UDP as transport layer for signalling messages.

At TTCN-3 system interface level there are no IMS specific ports or ASPs, i.e. IMS specific issues are purely handled in TTCN and therefore out of scope for this document.

NOTE: Even though the main intention to introduce the IMS test model is to support the initial IMS registration procedure, the IMS test model is independent of any specific IMS procedures.

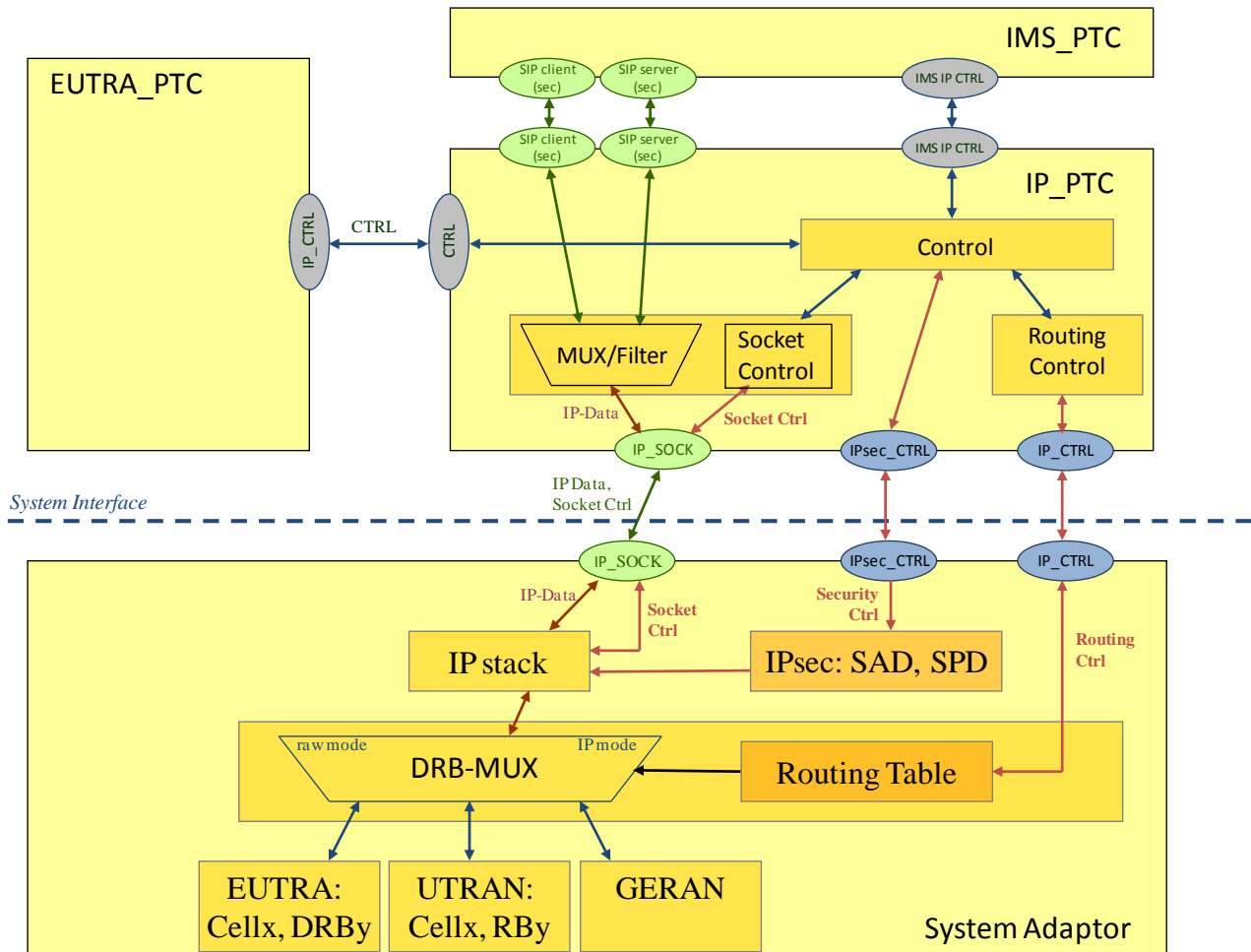

Figure 4.2.5-1: Example for IP model supporting IMS

NOTE 1: At the system interface IPsec is the only difference compared to the IP model of clause 4.2.4

NOTE 2: It is a working assumption to have a separate PTC for IMS as shown in figure 4.2.5-1

NOTE 3: Ports between the IP\_PTC and the IMS\_PTC are for illustration only

### 4.2.5.1 IPsec

IPsec involves security policy database (SPD) and security association database (SAD) (Ref. RFC4301). The entries in the databases are configured with security parameters by ASPs at the IPsec\_CTRL port.

NOTE: IPsec is not directly associated to a given socket but IPsec is applied to IP packets matching a configured security association. ⇒ configuration of IPsec in general is independent of the existence of sockets but typically the IPsec configuration is done just before establishment of a corresponding socket.

The SS shall cleanup all IPsec database entries which has been setup by TTCN during a test case at the end of the test case independent of how the test case terminates (normal termination, run-time error etc.)

#### 4.2.5.1.1 Security Association

NOTE: Within this clause SA is used as abbreviation of ‘Security Association’ (i.e. not as abbreviation for ‘System Adaptor’ as usual)

During the IMS signalling handling two pairs of SAs consisting of four unidirectional SAs will be used, one pair of SAs (SA2 and SA4) is between the server port of UE and the client port of the SS, another pair of SAs (SA 1 and SA3) is between the client port of UE and the server port of the SS, see figure 4.2.5.2.3.1-1.

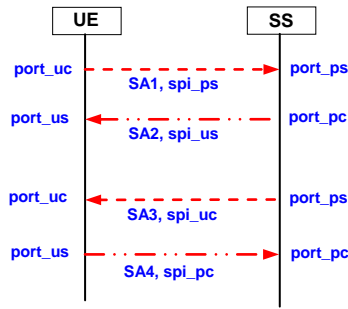

Figure 4.2.5.2.3.1-1 Two pairs of SAs

SA1 used for data flow from port\_uc to port\_ps is an inbound SA for protected server port of P-CSCF, its Security Parameter Index spi\_ps is selected by P-CSCF (IMS Registration/Authentication function in IP\_PTC) and presented in 401 Unauthorised; SA2 used for data flow from port\_pc to port\_us is an inbound SA for protected server port of UE, its Security Parameter Index spi\_us is selected by UE and presented in initial REGISTER message; SA3 used for data flow from port\_ps to port\_uc is an inbound SA for protected client port of UE, its Security Parameter Index spi\_uc is selected by UE and presented in initial REGISTER message; SA4 used for data flow from port\_us to port\_pc via an inbound SA for client port of P-CSCF, its Security Parameter Index spi\_pc is selected by P-CSCF (IMS Registration/Authentication function in IP\_PTC) and presented in 401 Unauthorised message. The pair of SA 1 and SA3 is for bidirectional traffic between port\_uc and port\_ps. The pair of SA2 and SA4 is for bidirectional traffic between port\_pc and port\_us. Those four spi\_xx and other security parameters are negotiated during security association set up procedure and shall be passed to IPsec protocol layer in the SS. See "SAD and SPD" and clause 7.2 of TS 33.203 [41].

These four unidirectional SA and relevant ports are shared by TCP and UDP. TCP transport will use all four SAs, UDP transport uses only two SAs, because there is no traffic from port\_ps to port\_uc, nor from port\_us to port\_pc. Figure 4.2.5.2.3.1-2 shows the usage of ports and SAs under UDP and TCP transport in a generic registration procedure (see clause C.2 of TS 34.229-1 [40]).

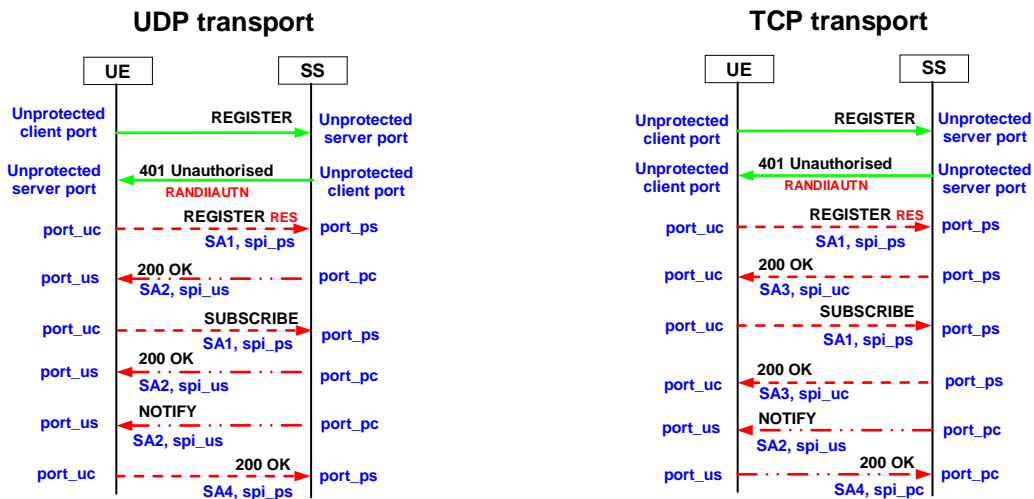

Figure 4.2.5.2.3.1-2: Usage of ports and SAs in UDP and TCP transport

4.2.5.1.2 SAD and SPD

SAD and SPD are used by IPsec to store various security parameters (per Security Association). During IMS AKA, the UE and the IMS Registration/Authentication function in IP\_PTC negotiates the negotiable parameters for security association setup, this negotiation is carried out at the SIP level in TTCN-3, and the resulting security association parameters are maintained in TTCN-3. The involved parameters are:

spi\_uc; spi\_us; spi\_pc; spi\_ps

encryption algorithm

integrity algorithm

The IMS AKA will generate key  $IK_{IM}$ , the security parameters  $IK_{ESP}$  and  $CK_{ESP}$  are derived from  $IK_{IM}$  and  $CK_{IM}$  in TTCN-3 (Ref. Annex I of TS 33.203[41]). ASPs are used to pass these parameters (per security association and with its selectors) from TTCN-3 to SAD and SPD of IPsec layer in the SS.

The same  $IK_{ESP}$  and  $CK_{ESP}$  will be used for the four unidirectional SAs. All of the four unidirectional SAs will use the same negotiated encryption algorithm and integrity algorithm.

In addition to those negotiable security parameters, other security parameters are fixed in IMS environment (see clause 7.1 of TS 33.203 [41]):

Life type:	second
SA duration:	$2^{32}-1$
Mode:	transport
IPsec protocol:	ESP, ESP integrity applied
Key length:	192 bits for DES-EDES_CBC, 128 bits for AES-CBC and HMAC-MD5-96; 160 bits for HMAC-SHA-1-96

These parameters are hard coded with IPsec implementation in the SS, not passed from TTCN-3.

An SA have to be bound to selectors (specific parameters) of the data flows between UE and P-CSCF (IMS Registration/Authentication function in IP\_PTC), the selectors are:

source IP address

destination IP address

source port

destination port

transport protocols that share the SA

IP addresses bound to the two pairs of SAs are:

For inbound SAs at the P-CSCF (the SS side):

- The source and destination IP addresses associated with the SA are identical to those in the header of the IP packet in which the initial SIP REGISTER message was received by the P-CSCF.

For outbound SAs at the P-CSCF (the SS side):

- The source IP address bound to the outbound SA equals the destination IP address bound to the inbound SA; the destination IP address bound to the outbound SA equals the source IP address bound to the inbound SA.

Ports bound to the two pairs of SAs are depicted in figure 4.2.5.2.3.1-1, port\_ps and port\_pc shall be different from the default SIP ports 5060 and 5061. The number of the ports port\_ps and port\_pc are communicated to the UE during the security association setup procedure.

The transport protocol selector shall allow UDP and TCP.

The selectors are passed to the SS IPsec layer together with the security parameters related to an SA bound to the selectors.

#### 4.2.5.2 Signalling Compression (SigComp)

Signalling compression is mandatory (see clause 8 of TS 24.229 [42]) and Signalling compression (RFC 3320 [43], RFC 3485 [44], RFC 3486 [45], RFC 4896 [46], RFC 5049 [47]) protocol is used for SIP compression. SigComp entity in the model is used to carry out the compression/decompression functions. In receiving direction of the SS the SigComp entity will detect whether the incoming SIP message is compressed, and decompress the message if it is

compressed. In the SS transmitting direction, the TTCN, via ASP, controls when the compression of outgoing SIP message is started. Stateless compression is not used in the SIP environment. For state full operation of SigComp the ASP passing compartment ID to SigComp is applied. The SS shall clean all states related to a connection in SigComp when an ASP for closing the connection is received. The SS shall also clean all states in the SigComp when abortion of a test case is detected or after the system reboots. If decompression failure occurs while decompressing a message, the message shall be discarded. The SigComp entity in the SS shall automatically find if a secure port or un-secure port is being used for transmission or reception of messages. If an un-secure port is used for transmission, it shall not include state creation instructions. If the state creation command is received in a compressed message on an un-secured port, a decompression failure shall be generated.

#### 4.2.5.3 SIP TTCN-3 Codec

SIP is a text-based protocol, the messages exchanged between the UE and the SS are character strings. In TTCN-3 the messages are structured to take the advantages of TTCN-3 functionalities, and to make the debugging and maintenance easier.

Even though there is no encoding/decoding of SIP messages at the TTCN-3 system interface, the IMS\_PTC uses the SIP codec by means of the TTCN-3 build-in functions encvalue and decvalue.

The SIP codec is specified in TS 34.229-3 [45] clause 7.

#### 4.2.6 Support of DSMIPv6

For testing of DSMIPv6 IP packets being relevant for the test cases may be routed by the IP\_PTC to the PTCs with specific test case implementation. There are not specific requirements for the system interface.

The functions of HA and ePDG are FFS.

### 4.2.7 MBMS test model

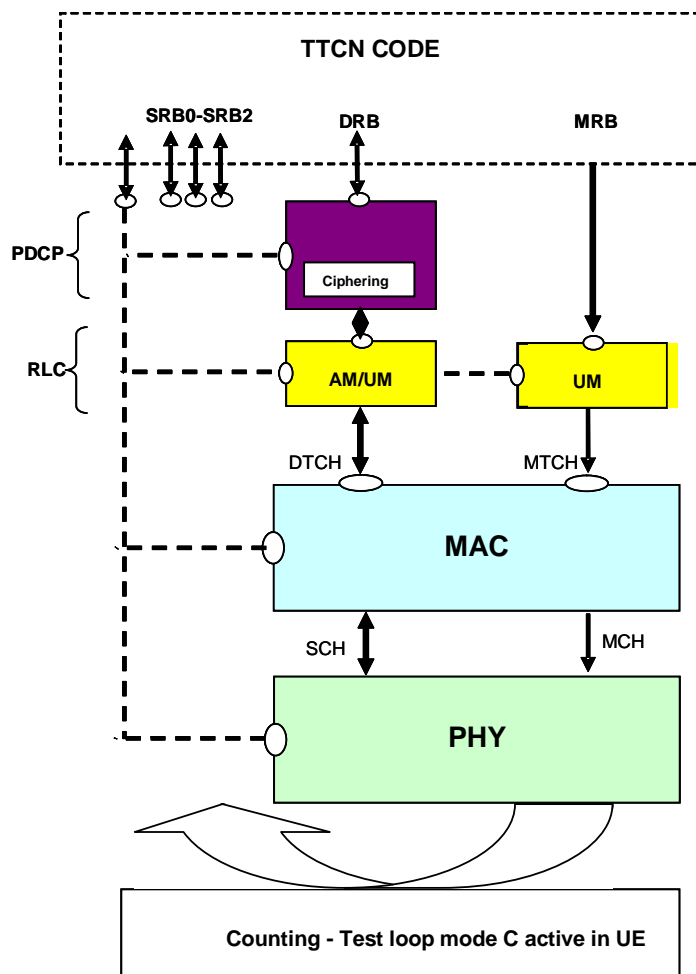

Figure 4.2.7-1: Test model for MBMS testing

The UE is configured in Test Loop Mode C to count the successfully received MBMS Packets. On the UE side, Ciphering/Integrity (PDCP and NAS) are enabled on SRBs/DRB. No security is configured on MCCH.MTCH.

On the SS side, the cell is configured as a normal cell, the MBMS parameters are configured by using an additional call of SYSTEM\_CTRL\_REQ. L1, MAC and RLC are configured for MCCH/MTCH in normal mode; they shall perform all of their functions. The MRB ports are above RLC. For MTCH data transmission, the SS shall set the MSI in the MAC header according to TS 36.321[16] clause 6.1.3.7.



## 4.3 SAE Test Model

### 4.3.1 NAS Test Model

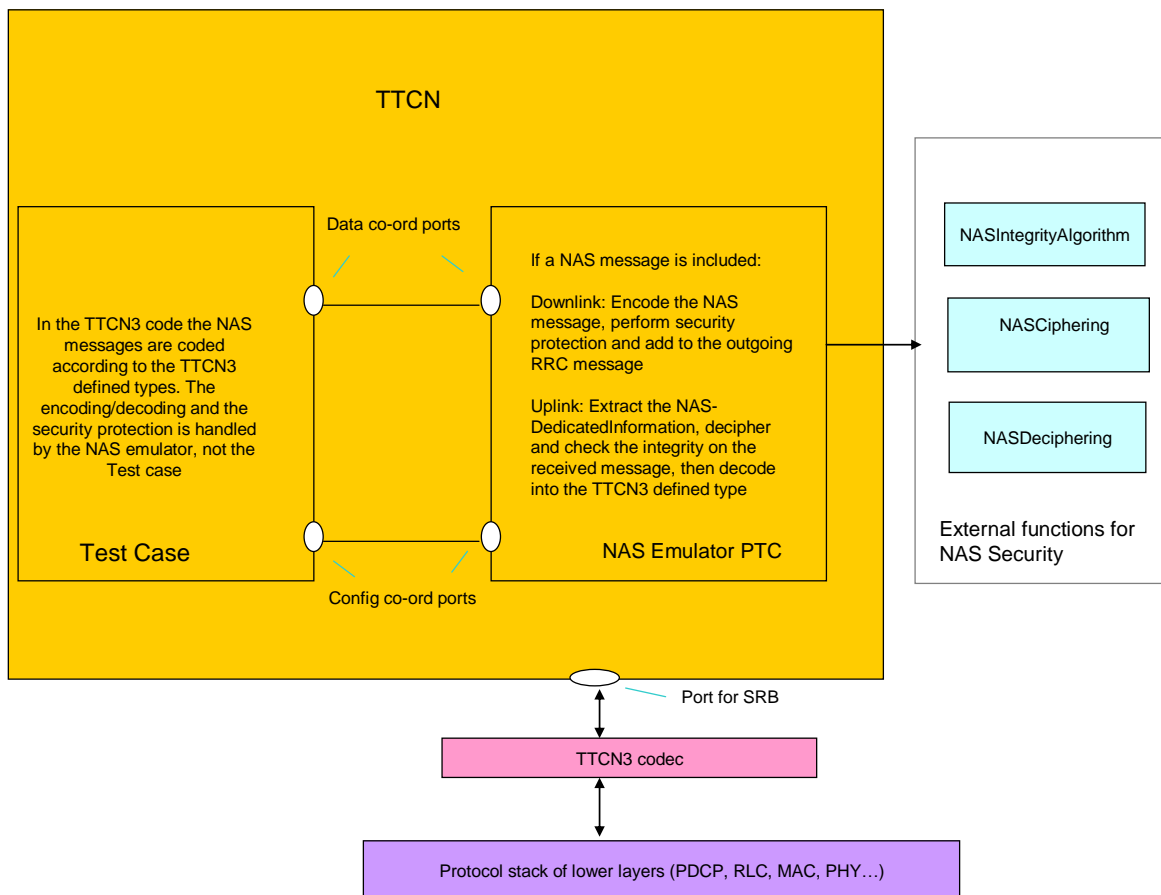

**Figure 4.3.1-1: NAS Test Model**

The NAS emulator is a parallel test component which handles NAS security, with the help of external functions to perform the integrity and (de)cipherng.

The interface between the emulator and the TTCN (co-ordination messages) handle data as TTCN-3 values. The interface between the emulator and the SS handles the RRC messages as TTCN-3 values, containing (where applicable) secure, encoded NAS messages.

The NAS emulator is not part of the test case in terms of verdict assignment (i.e. it does not check the correctness of any protocol message). Nevertheless, in case of fatal errors such as encode/decode errors, the NAS emulator sets the verdict to inconclusive and terminates immediately - which causes the test case to terminate. I.e. the NAS emulator does not resolve error situations.

## 4.4 Inter RAT Test Model

### 4.4.1 E-UTRAN-UTRAN Inter RAT Test Model

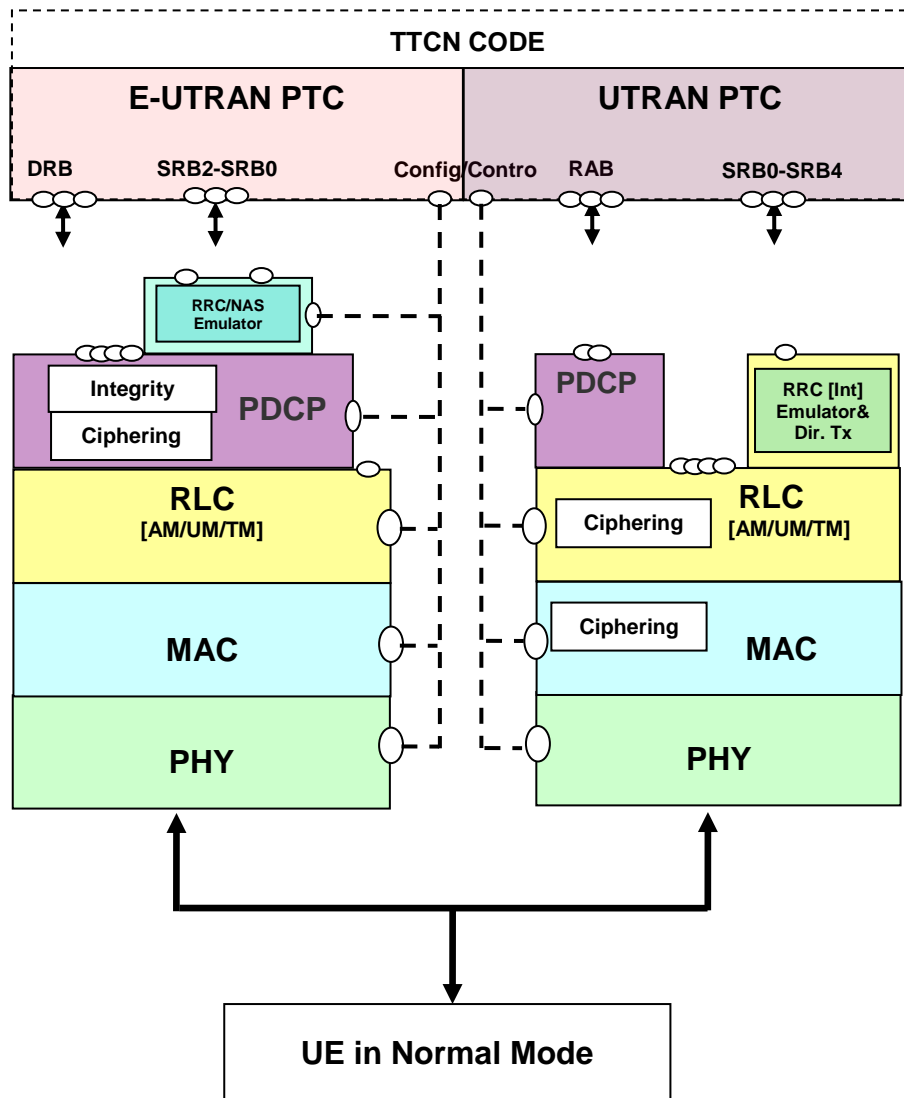

Figure 4.4.1-1: Test model for Inter RAT E-UTRAN-UTRAN testing

The model consists of dual protocol stack one for E-UTRAN and one for UTRAN. The TTCN implementation for E-UTRAN and UTRAN functionalities will be in separate Parallel Test Components. The SS E-UTRAN part is same as the model defined in clause 4.2.2 for RRC testing.

The SS UTRAN part consisting of PHY, MAC, RLC and PDCP (optionally) (IF PS user RB established only), are configured in normal mode. They shall perform all of their functions normally. Ciphering is enabled and shall be performed in RLC (AM/UM) and MAC (TM RLC). Integrity is enabled, and SS shall provide RRC emulator for integrity protection calculation and checking and 'Direct transfer' adaptation. Ports are above RLC (CS RAB and SRB0), PDCP (PS RAB) and RRC Emulator (SRB1 to SRB4).

The UE is configured in normal mode. Ciphering/Integrity (PDCP and NAS) are enabled and ROHC is not configured in E-UTRAN. Ciphering is enabled in UTRAN.

#### 4.4.1.1 User data over UTRAN

User data transferred over UTRAN is distinguished between:

Raw user data (raw mode),

IP data (IP mode).

Depending upon whether the user data is relevant for the purpose of test, several scenarios are listed:

Raw user data relevant for the purpose of test,

IP data relevant for the purpose of test,

IP data, considered as IP signalling, not directly relevant for the purpose of test.

#### 4.4.1.1.1 Raw user data over UTRAN

The raw user data can be as RLC SDUs and PDCP SDUs. The DL and UL user data are routed to UTRAN\_PTC (Fig. 4.4.1.1.2-1). The IP stack in SS is not involved for all raw user data applications.

RLC SDUs is applied if the test loop mode 1 with loopback of RLC SDUs in TS 34.109 [9] is activated. PDCP in SS is not configured in this case; the DL and UL user data are routed to UTRAN\_PTC via the RLC port.

The raw user data as PDCP SDUs is applied in the following cases:

the test loop mode 4 (TS 34.109 [9]) is activated,

the test loop mode 1 is activated with loopback of PDCP SDUs (TS 34.109 [9]),

the test loop mode B (TS 36.509 [4]) is activated and raw data is looped back on UTRAN,

IP raw data is another type of raw user data. The test loop mode is not activated. This case is applied when sending uplink data is triggered by the upper tester.

PDCP and optional RoHC are configured in SS, the DL and UL user data are routed to UTRAN\_PTC via the PDCP port.

Feeding raw user data is largely used in the pure UTRAN test in TS 34.123-3 [7].

#### 4.4.1.1.2 IP data over UTRAN

The IP data over UTRAN is applied to E-UTRA-UTRAN I-RAT and UTRAN test cases. The IP stack in SS is involved. IP data is considered as:

IP packets data (IP mode) relevant for the purpose of test,

IP signalling (IP mode), to be handled in TTCN at IP Layer

One of the IP signalling handling is the stateless address auto configuration for IPv6, illustrated in Fig. 4.4.1.1.2-1.

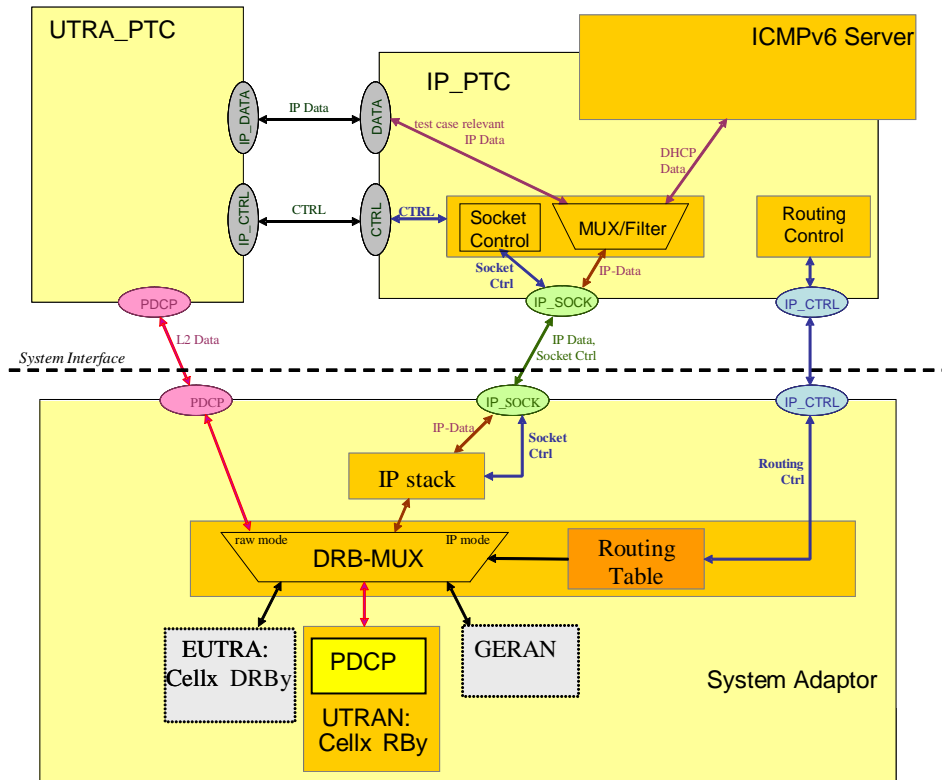

Figure 4.4.1.1.2-1: UTRAN IP test model with an ICMPv6 server

#### 4.4.1.1.3 Routing IP data

The routing of user data is the function of DRB-Mux and controlled by a routing table.

If there is no entry in the routing table for a given RB, it is considered being in raw mode, raw user data is routed to or from the UTRAN PDCP port.

If there is an entry in the routing table for a given RB, it is considered being in IP mode, IP data is routed to or from the IP stack.

For EUTRA-UTRAN or UTRAN test, the routing entry parameters in the DRB-Mux's routing table are specified as (RAT=Utran, cell-id=-1, RB id). SS PDCP entity does not belong to a particular cell; the cellId shall be assigned to the value -1. Consequently, the UTRAN cell id provided in DRB-Mux is set to cell-id=-1.

IP protocol information of IP data (protocol, local IP address, local port, remote IP address, and remote port) is also provided in the routing table. More information can be found in 4.2.4.

### 4.4.2 E-UTRAN-GERAN Inter RAT Test Model

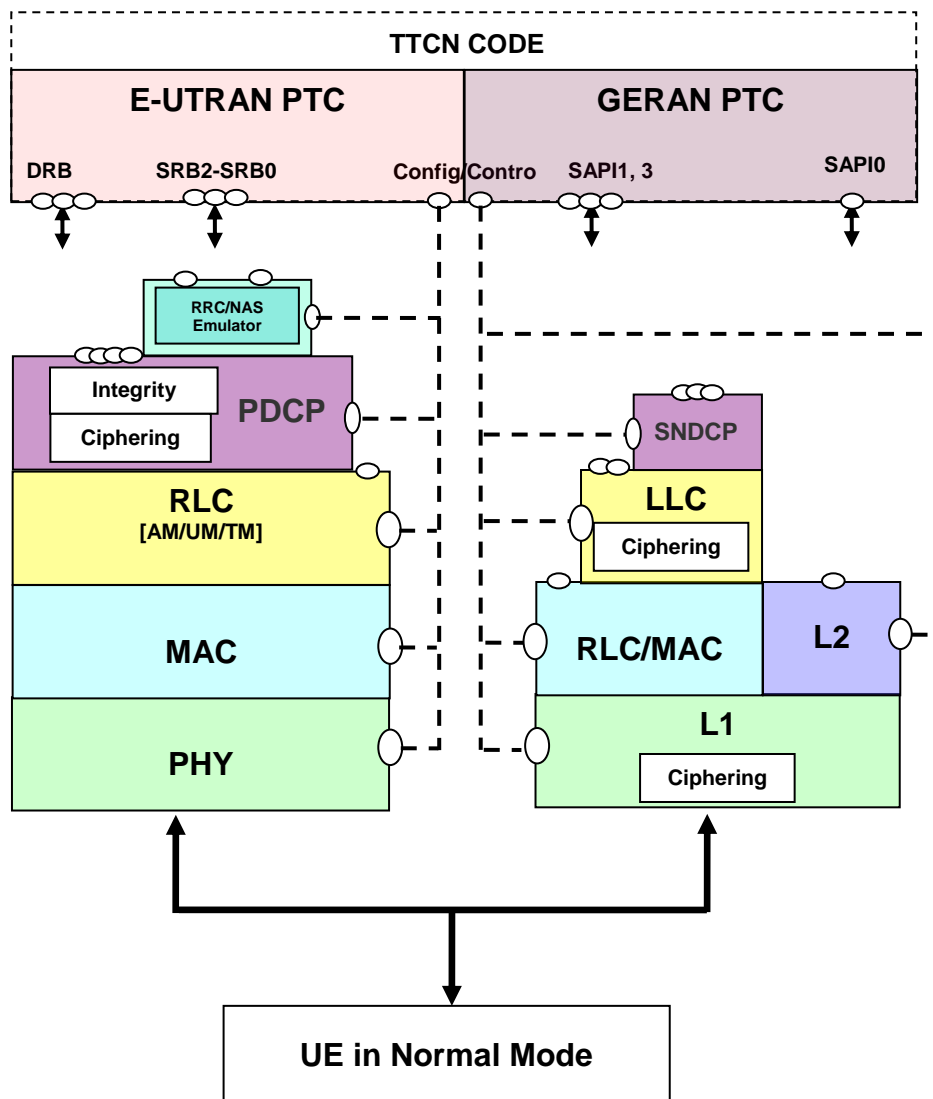

**Figure 4.4.2-1: Test model for Inter RAT E-UTRAN-GERAN testing**

The model consists of dual protocol stack one for E-UTRAN and one for GERAN. The TTCN implementation for E-UTRAN and GERAN functionalities will be in separate Parallel Test Components. The SS E-UTRAN part is the same as the model defined in clause 4.2.2 for RRC testing.

The SS GERAN model for GPRS consists of L1, MAC/ RLC and LLC, configured in normal mode. SNDCP may also be configured. They shall perform all of their functions normally. Ciphering is enabled and shall be performed in LLC. Ports are above RLC (GRR messages), LLC (NAS and Data) and SNDCP (User Data).

The SS GERAN model for GSM consists of L1, L2 (MAC/ RLC), configured in normal mode. They shall perform all of their functions normally. Ciphering is enabled and shall be performed in L1. Ports are above L2.

The UE is configured in normal mode. Ciphering/Integrity (PDCP and NAS) are enabled and ROHC is not configured in E-UTRAN. Ciphering is enabled in GERAN.

#### 4.4.2.1 User data over GERAN

User data transferred over GERAN is distinguished between:

- Raw user data (raw mode),

IP data (IP mode).

Depending upon whether the user data is relevant for the purpose of test, several scenarios are listed:

Raw user data relevant for the purpose of test,

IP data relevant for the purpose of test,

IP data, considered as IP signalling, not directly relevant for the purpose of test.

#### 4.4.2.1.1 Raw user data over GERAN

The raw user data can be as RLC blocks and SDCP SDUs. The DL and UL user data are routed to GERAN PTC (Fig. 4.4.2.1.2-1). The IP stack in the SS is not involved for all raw user data applications.

RLC blocks are applied if testloop mode B (TS 36.509 [4]) is activated and raw data is looped back on GERAN.

IP raw data is another type of raw data. The testloop mode is not activated. This case is applied when sending uplink data is triggered by the upper tester.

SDCP and optionally RoHC are configured in the SS, DL and UL user data are routed to GERAN\_PTC via the SDCP port.

#### 4.4.2.1.2 IP data over GERAN

The IP data over GERAN is applied to EUTRA – GERAN I-RAT test cases. The IP stack in the SS is involved. IP data is considered as:

- IP packets data (IP mode) relevant for the purpose of the test,
- IP signalling (IP mode), to be handled in the TTCN at IP layer.

One of the IP signalling handling is the stateless address auto configuration for IPv6, illustrated in Figure 4.4.2.1.2-1.

**Figure 4.4.2.1.2-1: GERAN IP test model with an ICMPv6 server**

#### 4.4.2.1.3 Routing IP data

The routing of user data is the function of the DRB-Mux and is controlled by a routing table.

If there is no entry in the routing table for a given NSAPI, it is considered to be in raw mode, raw user data is routed to or from the GERAN SDCP port.

If there is an entry in the routing table for a given NSAPI, it is considered to be in IP mode, IP data is routed to or from the IP stack.

For EUTRA-GERAN, the routing entry parameters in the DRB-Mux's routing table are specified as (RAT = GERAN, cell-id, NSAPI). IP protocol information of IP data (protocol, local IP address, local port, remote IP address, and remote port) is also provided in the routing table. More information can be found in clause 4.2.4.

### 4.4.3 E-UTRAN-CDMA2000 Inter RAT Test Model

#### 4.4.3.1 E-UTRAN-CDMA2000 HRPD Inter RAT Test Model

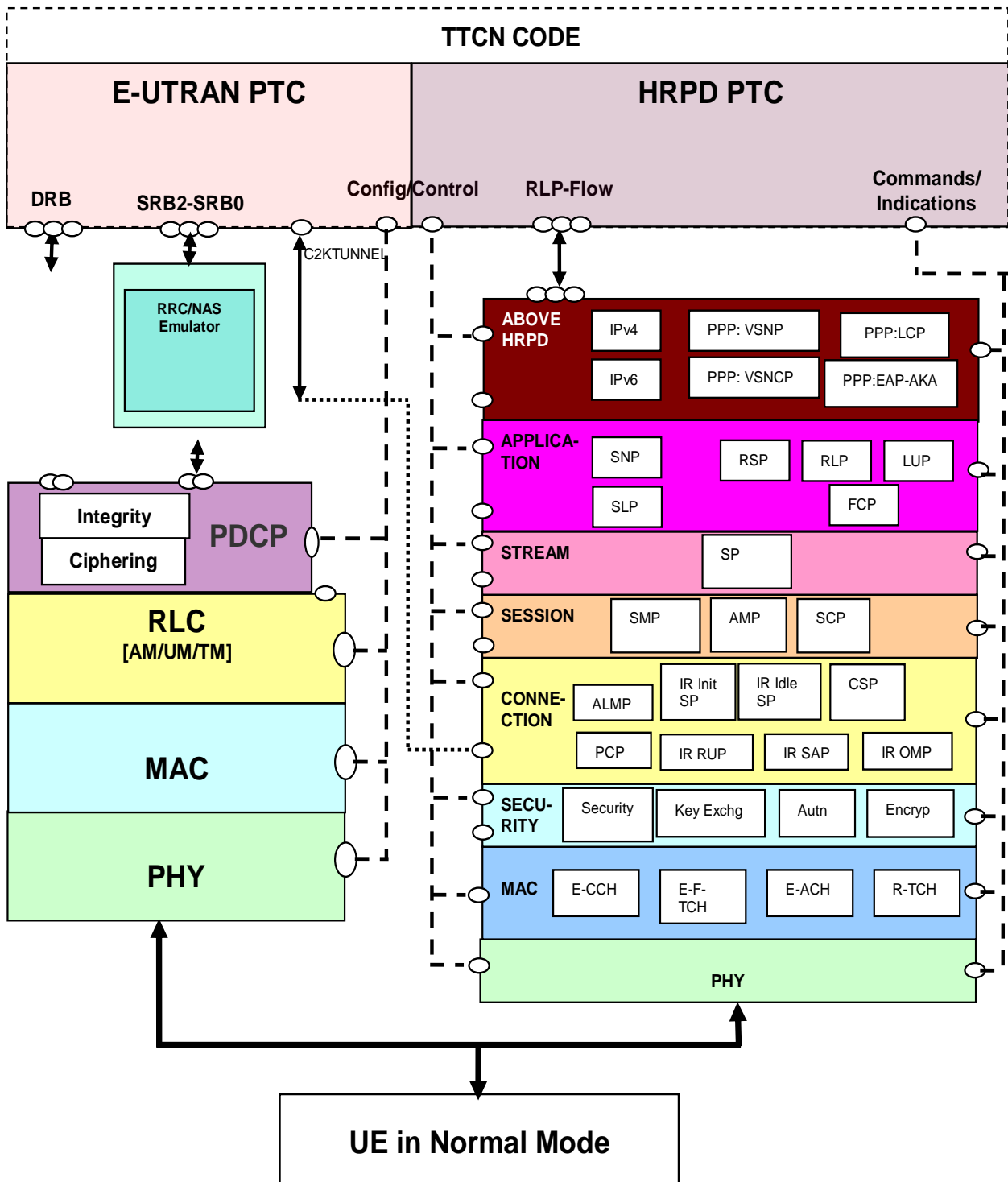

Figure 4.4.3-1: Test model for InterRAT E-UTRAN-CDMA2000 HRPD testing

The model consists of a dual protocol stack, one for E-UTRAN and one for eHRPD. The TTCN implementation for E-UTRAN and eHRPD functionalities will be in separate Parallel Test Components. The SS E-UTRAN part is same as the model defined in clause 4.2.2 for RRC testing.

The eHRPD part emulation in SS is considered as a black box. The commands/Indications port is used for commanding the SS to bring the UE into the desired state and monitoring the progress. The System commands and indications are designed with principle of having minimum command/indication per eHRPD procedure hence avoid racing conditions and timing issues. By default, the execution order of sub procedures (e.g. protocol negotiations) cannot be monitored by TTCN. The SS emulations shall be compliant with respective 3GPP/3GPP2 core specifications and guarantee execution order of respective eHRPD procedures as per relevant 3GPP/3GPP2 test/core specifications.

The C2KTUNNEL port is used for routing encapsulated

1. pre-registration messages (i.e. messages encapsulated in *ULInformationTransfer* and *DLInformationTransfer*) in the EUTRAN cell to the eHRPD and
2. handover related eHRPD messages (i.e. messages encapsulated in *HandoverFromEUTRAPreparationRequest/ULHandoverPreparationTransfer/ MobilityFromEUTRACommand*).

The SS eHRPD part consists of Physical, MAC, Security, Connection, Session, Stream, Application and Layers for PPP and IP configured in normal mode. They shall perform all of their functions normally. Encryption may be enabled and performed in security layer.

The CDMA2000 eHRPD emulation in the SS supports the following layers and protocols:

- Physical layer (Subtype 2).
- MAC layer:
  - Enhanced (Subtype 0, Subtype 1) Control Channel MAC Protocol (ECH).
  - Enhanced (Subtype 1) Forward Traffic Channel MAC Protocol (E-F-TCH).
  - Enhanced (Subtype 1) Access Channel MAC Protocol (E-ACH).
  - Subtype 3 Reverse Traffic Channel MAC Protocol (R-TCH).
- Security Layer:
  - Default Security Protocol (Security).
- Connection Layer:
  - Default Air Link Management Protocol (ALMP).
  - Default Connected State Protocol (CSP).
  - Default Packet Consolidation Protocol (PCP).
  - Inter-RAT Signalling Adaptation Protocol (IR-SAP) (required only for optimized handover).
  - Inter-RAT Initialization State Protocol (IR-Init SP) (required only for optimized handover).
  - Inter-RAT Idle State Protocol (IR-Idle SP) (required only for optimized handover).
  - Inter-RAT Route Update Protocol (IR-RUP) (required only for optimized handover).
  - Inter-RAT Overhead Messages Protocol (IR-OMP) (required only for optimized handover).
- Session Layer:
  - Default Session Management Protocol (SMP).
  - Default Address Management Protocol (AMP).
  - Default Session Configuration Protocol (SCP).
- Stream Layer:



- Default Stream Protocol (DSP).
- Application Layer:
  - Default Signalling Application:
    - Signalling Network Protocol (SNP).
    - Signalling Link Protocol (SLP).
  - Enhanced Multi-Flow Packet Application:
    - Route Selection Protocol (RSP).
    - Radio Link Protocol (RLP).
    - Location Update Protocol (LUP).
    - Flow Control Protocol (FCP).
  - Alternate Enhanced Multi-Flow Packet Application (to be listed along with EMPA during SCP negotiation)
- Above eHRPD:
  - PPP: Vendor Specific Network Control Protocol (PPP:VSNCP).
  - PPP: Vendor Specific Network Protocol (PPP:VSNP).
  - PPP: Link Control Protocol (PPP:LCP).
  - PPP: Extensible Authentication protocol-Authentication and Key Agreement' (PPP:EAP-A KA').
  - IPv4.
  - IPv6.

During pre-registration phase, one cell per preRegistrationZoneID (ColorCode) to be simulated will be configured by TTCN with power level as 'off', or as specified by the test case. The SS will be issued System commands for pre-registration and expect the appropriate system indications.

The UE is configured in normal mode. Ciphering/Integrity (PDCP and NAS) are enabled and ROHC is not configured in E-UTRAN. Encryption is enabled in HRPD.

#### 4.4.3.2 E-UTRAN-CDMA2000 1xRTT Inter RAT test model

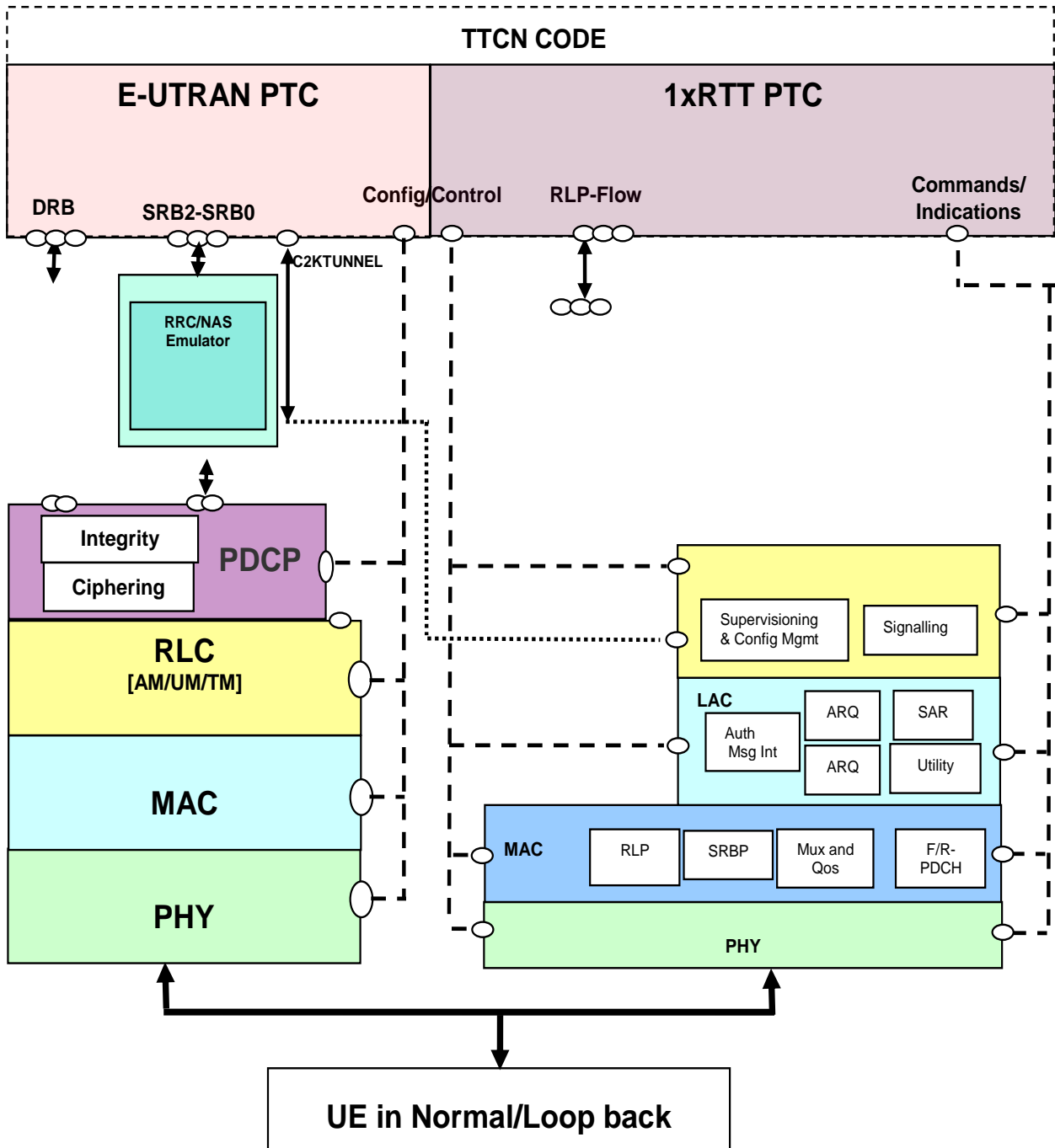

Figure 4.4.3.2-1: Test model for InterRAT E-UTRAN-CDMA2000 1xRTT testing

The 1xRTT test model consists of a dual protocol stack, one for E-UTRAN and one for 1xRTT. The TTCN implementation for E-UTRAN and 1xRTT functionalities are in separate Parallel Test Components. The SS E-UTRAN part is same as the model defined in clause 4.2.2 for RRC testing.

The 1xRTT part emulation in SS is considered as a black box. The commands/Indications port is used for commanding the SS to bring the UE into the desired state and monitoring the progress. The System commands and indications are designed with principle of having minimum command/indication per 1xRTT procedures hence avoid racing conditions and timing issues. By default, the execution order of sub procedures(e.g. protocol negotiations) cannot be monitored by TTCN. The SS emulations shall be compliant with respective 3GPP/3GPP2 core specifications and guarantee execution order of respective 1xRTT procedures as per relevant 3GPP/3GPP2 test/core specifications.

The C2KTUNNEL port is used for routing encapsulated

1. pre-registration messages (i.e. messages encapsulated in *CSFBParametersResponseCDMA2000*, *ULInformationTransfer* and *DLInformationTransfer*) in the EUTRAN cell to the 1xRTT and
2. handover, e-CSFB related 1xRTT messages (i.e. messages encapsulated in *HandoverFromEUTRAPreparationRequest*/*ULHandoverPreparationTransfer*/*MobilityFromEUTRACommand*).

The SS 1xRTT part consists of Physical, MAC, LAC, Session, Stream, Application and Layers for PPP and IP configured in normal mode. They shall perform all of their functions normally. Encryption may be enabled and performed in security layer.

The CDMA2000 1xRTT emulation in the SS supports the following layers and protocols:

- Physical layer.
- MAC layer:
  - Signalling Radio Burst protocol.
  - Radio Link Protocol for Data services.
  - Forward and Reverse Packet Data Channel functions.
  - Multiplexing and QoS Delivery.
- Link Access Control:
  - Authentication and Message Integrity sublayer [optional].
  - ARQ sublayer.
  - Addressing.
  - Utility.
  - Segmentation and Reassembly.
- Layer 3:
  - Supervisioning and Configuration Management.
  - Signalling Protocol.

During pre-registration phase, one cell per *preRegistrationZoneID* (*ColourCode*) to be simulated will be configured by TTCN with power level as 'off', or as specified by the test case. The SS will be issued System commands for pre-registration and expect the appropriate system indications.

The UE is configured in normal mode or loop back mode. Ciphering/Integrity (PDCP and NAS) are enabled and ROHC is not configured in E-UTRAN. Encryption may be enabled in 1xRTT.

### 4.4.4 E-UTRAN FDD-TDD Inter RAT Test Model

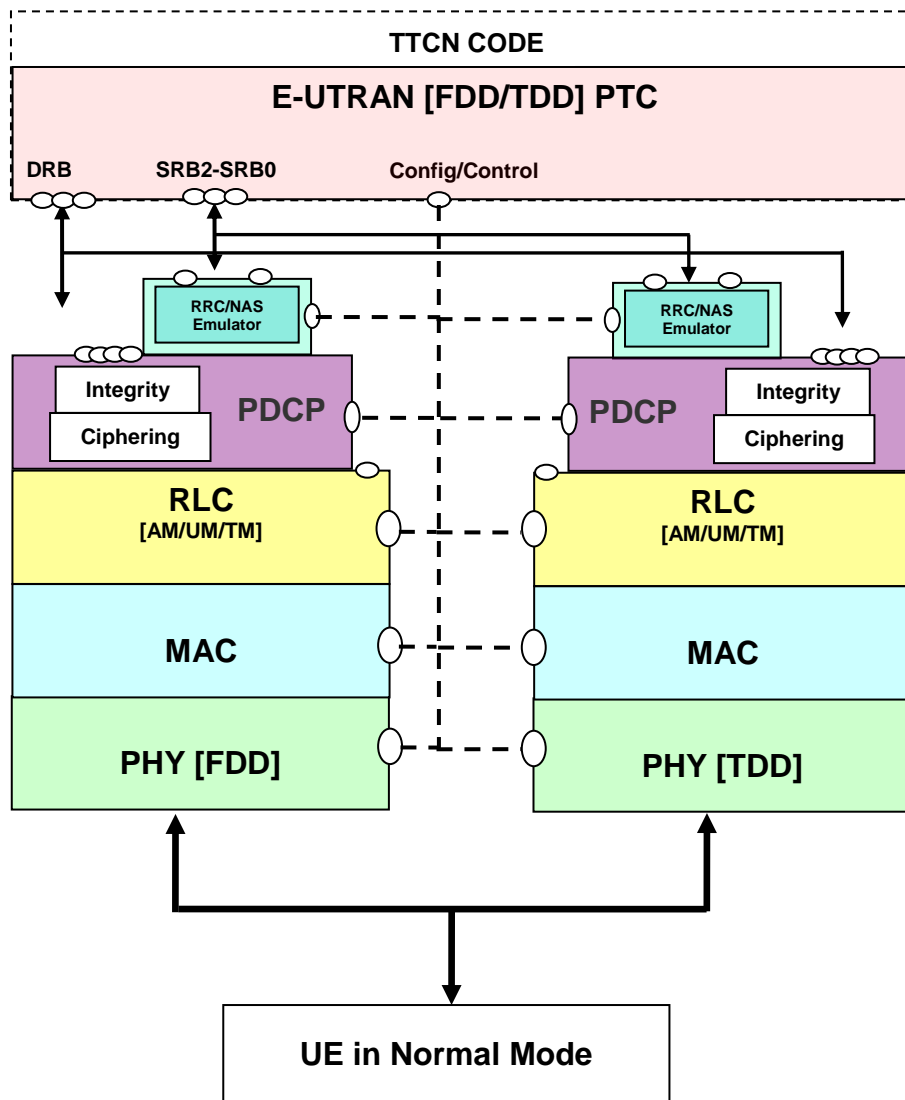

**Figure 4.4.4-1: Test model for Inter RAT E-UTRANFDD-TDD testing**

The model consists of dual protocol stack one for E-UTRANFDD and one for E-UTRANTDD. The TTCN implementation for E-UTRANFDD and TDD functionalities will be in the same Parallel Test Component. The SS E-UTRAN (both FDD and TDD) part is the same as the model defined in clause 4.2.2 for RRC testing. SS E-UTRANFDD and TDD shall be configured as separate cells.

The UE is configured in normal mode. Ciphering/Integrity (PDCP and NAS) are enabled and ROHC is not configured for both FDD and TDD.

### 4.4.5 E-UTRAN-UTRAN-GERAN Inter RAT Test Model

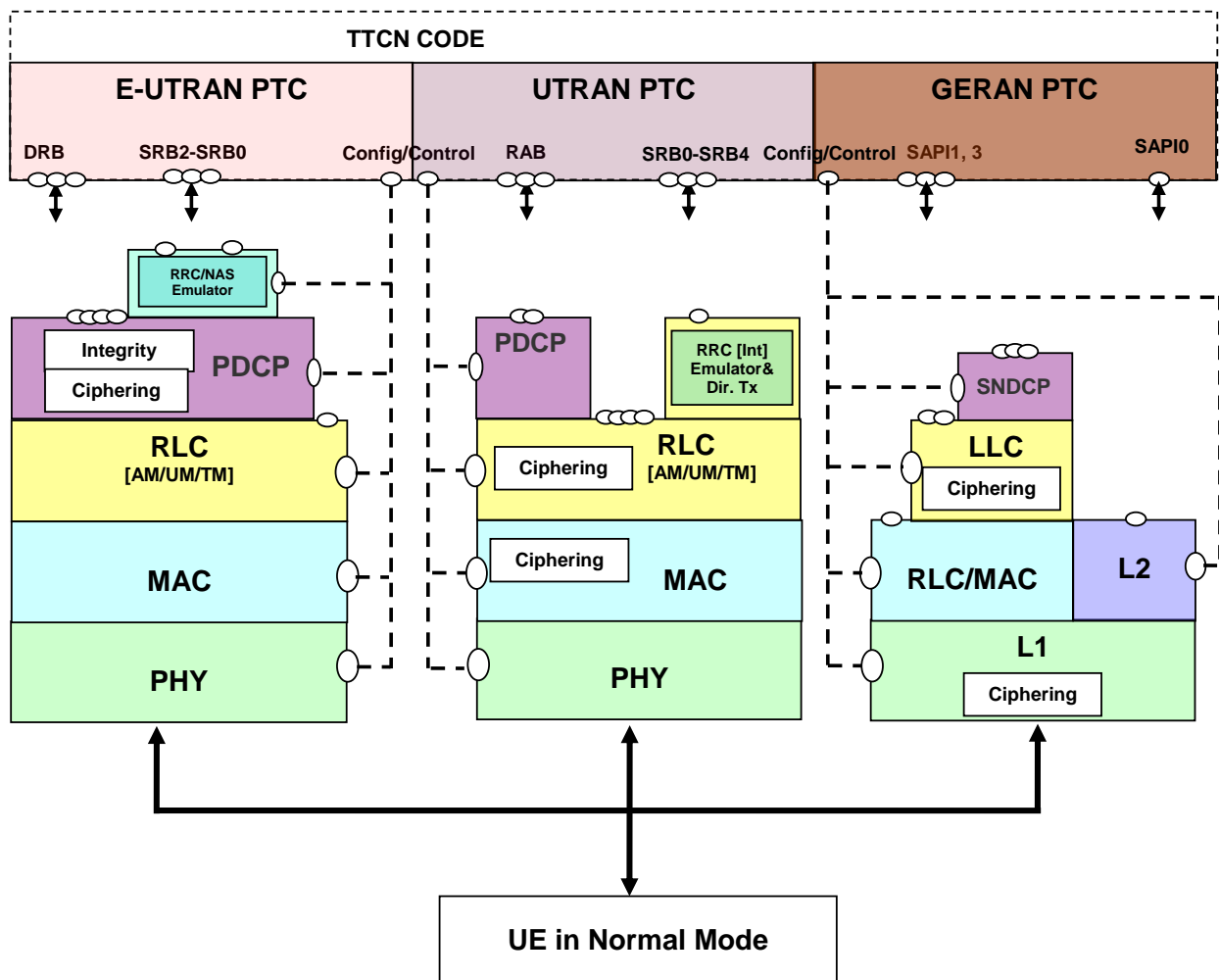

Figure 4.4.5-1: Test model for Inter RAT E-UTRANFDD-TDD testing

The model consists of integrated protocol stack supporting E-UTRAN, UTRAN and GERAN. The TTCN implementation for E-UTRAN, UTRAN and GERAN functionalities will be in separate Parallel Test Components. The SS E-UTRAN part is the same as the model defined in clause 4.2.2 for RRC testing. The SS UTRAN part is the same as the model defined in clause 4.4.1. The SS GERAN part is same as the model defined in clause 4.4.2.

The UE is configured in normal mode. Ciphering/Integrity (PDCP and NAS) are enabled and ROHC is not configured in E-UTRAN. Ciphering/Integrity are enabled in UTRAN. Ciphering is enabled in GERAN.

## 5 Upper Tester Interface

This clause describes the handling of AT commands and MMI Commands at the system interface. The internal handling of those commands in TTCN is out of scope.

In the TTCN, the Upper Tester is located at the MTC; therefore there is one interface to the system adaptor common for all RATs.

There is one primitive defined carrying either an MMI or an AT command to be sent to the system adaptor and one common confirmation primitive to be sent by the system adaptor.

TTCN-3 ASP Definition			
Type Name	UT_SYSTEM_REQ		
TTCN-3 Type	Record		
Cmd	TTCN-3 Type	union	
AT	charstring carrying the AT command as defined in TS 27.007 [32], TS 27.005 [31] and TS 27.060 [33]		
MMI	<ul style="list-style-type: none"> <li>• Cmd (charstring)</li> <li>• List of parameters: <ul style="list-style-type: none"> <li>○ Name (charstring)</li> <li>○ Value (charstring)</li> </ul> </li> </ul>		
CnfRequired	TTCN-3 Type	Ut_CnfReq_Type	
	<p><b>CNF_REQUIRED:</b> system adaptor shall reply with confirmation received from the UE</p> <p><b>NO_CNF_REQUIRED:</b> SS shall swallow any confirmation generated by the UE</p> <p><b>LOCAL_CNF_REQUIRED:</b> SS shall immediately send confirmation when the command is submitted to the UE i.e. in case of MMI when the operator has confirmed the command, but SS shall not wait for the UE responding.</p> <p>NOTE: In the TTCN, a confirmation shall only be requested in cases when there is no signalling from the UE being triggered by the MMI/AT command</p>		

TTCN-3 ASP Definition			
Type Name	UT_COMMON_CNF		
TTCN-3 Type	Record		
Result	TTCN-3 Type	boolean	
	<p><b>true:</b> success</p> <p><b>false:</b> failure</p>		
ResultString	TTCN-3 Type	charstring	
	response by the UE for commands which request the UE to return a result, optional		

All mandatory and optional AT commands are sent as AT command strings as defined above. If an optional AT command is not implemented in the UE, the system adaptor needs to parse the AT command and map it to an appropriate MMI command (which is out of scope for this document).

The following MMI commands are defined.

Table 5.1: MMI commands

Command	Parameters	
	Name	Value
"SWITCH_ON"	(none)	
"SWITCH_OFF"	(none)	
"POWER_ON"	(none)	
"POWER_OFF"	(none)	
"INSERT_USIM"	"USIM"	<USIM>
"REMOVE_USIM"	(none)	
"CHECK_PLMN"	"PLMN"	<PLMN ID>
"CHECK_ETWS_INDICATION"	"WARNING1"	<WARNING1>
	"WARNING2"	<WARNING2>
"CHECK_ETWS_ALERT"	(none)	
"CHECK_ETWS_NO_ALERT"	(none)	
"CHECK_CMAS_INDICATION"	"WARNING1"	<WARNING1>
	"WARNING2"	<WARNING2>
"CHECK_CMAS_ALERT"	(none)	
"CHECK_CMAS_NO_ALERT"	(none)	
"HRPD_PDN_CONNECTION"	(none)	
"CHECK_MESSAGE_DISPLAYED"	"Length"	<Length>
	"Msg"	<Msg>
"CHECK_SMS_LENGTH_CONTENTS"	"Length"	<Length>
	"Msg"	<Msg>
"DISABLE_EPS_CAPABILITY"	(none)	
"DETACH_NON_EPS"	(none)	
"CLEAR_STORED_ASSISTANCE_DATA"	(none)	
"CHECK_DTCH_THROUGHCONNECTED"	(none)	
"GERAN_UPLINK_DATA"	(none)	
"SELECT_CSG"	"PLMN"	<PLMN ID>
	"CSG"	<CSG ID>
"TRIGGER_USER_RESELECTION"	(none)	
"REQUEST_NON_CALL_RELATED_SS"	(none)	
"LOCATION_INFO"	(none)	
"JOIN_MBMS_SERVICE"	TMGI_Id	
"CHECK_ETWS_INDICATION"	"WARNING1"	<WARNING1>
	"WARNING2"	<WARNING2>
"CHECK_CMAS_INDICATION"	"WARNING1"	<WARNING1>
	"WARNING2"	<WARNING2>

The following AT commands are applied in TTCN.

Table 5.2: AT Commands

Command	Reference
ATD	TS 27.007 [32]
ATA	TS 27.007 [32]
ATH	TS 27.007 [32]
AT+CGEQOS	TS 27.007 [32]
AT+CGTFT	TS 27.007 [32]
AT+CGDSCONT	TS 27.007 [32]
AT+CGACT	TS 27.007 [32]
AT+CGCMOD	TS 27.007 [32]
AT+CGDCONT	TS 27.007 [32]
AT+CMGD	TS 27.005 [31]
AT+CSMS	TS 27.005 [31]
AT+CPMS	TS 27.005 [31]
AT+CMGF	TS 27.005 [31]
AT+CSCS	TS 27.007 [32]
AT+CSCA	TS 27.005 [31]
AT+CMGW	TS 27.005 [31]
AT+CMSS	TS 27.005 [31]
AT+CSMP	TS 27.005 [31]
AT+CGEQREQ	TS 27.007 [32]
AT+CCLK	TS 27.007 [32]
AT+COPS	TS 27.007 [32]
AT+CGATT	TS 27.007 [32]
AT+CVMOD	TS 27.007 [32]
AT+CEMODE	TS 27.007 [32]
AT+CPBR	TS 27.007 [32]
AT+CPBS	TS 27.007 [32]

AT commands are referred to TS 27.005 [31], TS 27.007 [32] and TS 27.060 [33].

---

## 6 ASP specifications

### 6.1 General Requirements and Assumptions

The following common requirements affect ASP definitions:

- The definition of ASPs shall have no impact on the common system architecture or on the performance.
- The codec implementation is out of scope of the present document.
- For peer-to-peer PDUs contained in an ASP encoding rules need to be considered acc. to the respective protocol:
  - ASN.1 BER and PER.
  - Tabular notation for NAS PDUs or layer 2 data PDUs.

There are no encoding rules being defined for top level ASP definitions and information exchanged between the test executable and the System Adaptor (SA) only. Instead encoding depends on implementation of the codec and the SA.

There are no encoding rules being defined for ASPs between TTCN-3 components. This is implementation dependent.

Info elements defined in the protocol specifications (e.g. RRC) shall be re-used in configuration ASPs as far as possible.

For optional fields within the configuration ASPs, the following rules will be applied:

- For ASN.1 fields - these will follow the same rules as defined in the RRC specification [19].
- For TTCN-3 fields - when the current configuration of an optional field is to be 'kept as it is' then the field will be set to omit.



- For TTCN-3 fields - when the current configuration of an optional field is to be released/deleted then a separate option is provided in a union.

## 6.1.1 IP ASP requirements

## 6.1.2 Enhancement of IP ASP for handling IMS signalling

The IMS test model handling registration signalling introduces IPsec and SigComp layers into the IP test model in Figure 4.2.5.2-1. The ASP on system port IP\_SOCK needs to be enhanced to provide additional configuration/control functions for IPsec and SigComp. The enhanced IP ASP should contain:

1. Function to clean all IPsec and SigComp configurations and to put the IPsec and SigComp in the initial state.
2. Function to return SigComp layer a Compartment Id instructing SigComp layer to save the state of a received message which was compressed.
3. Function to start or stop signalling compression in sending direction (the SS to the UE) of SigComp.
4. Function to set security parameters (per security association) in IPsec layer.
5. A flag indicating whether SigComp layer shall be included in the data path when establishing a connection.
6. A flag indicating whether the received message was compressed by SigComp.
7. A parameter to point to a compartment used by SigComp to send a message.

## 6.2 E-UTRAN ASP Definitions

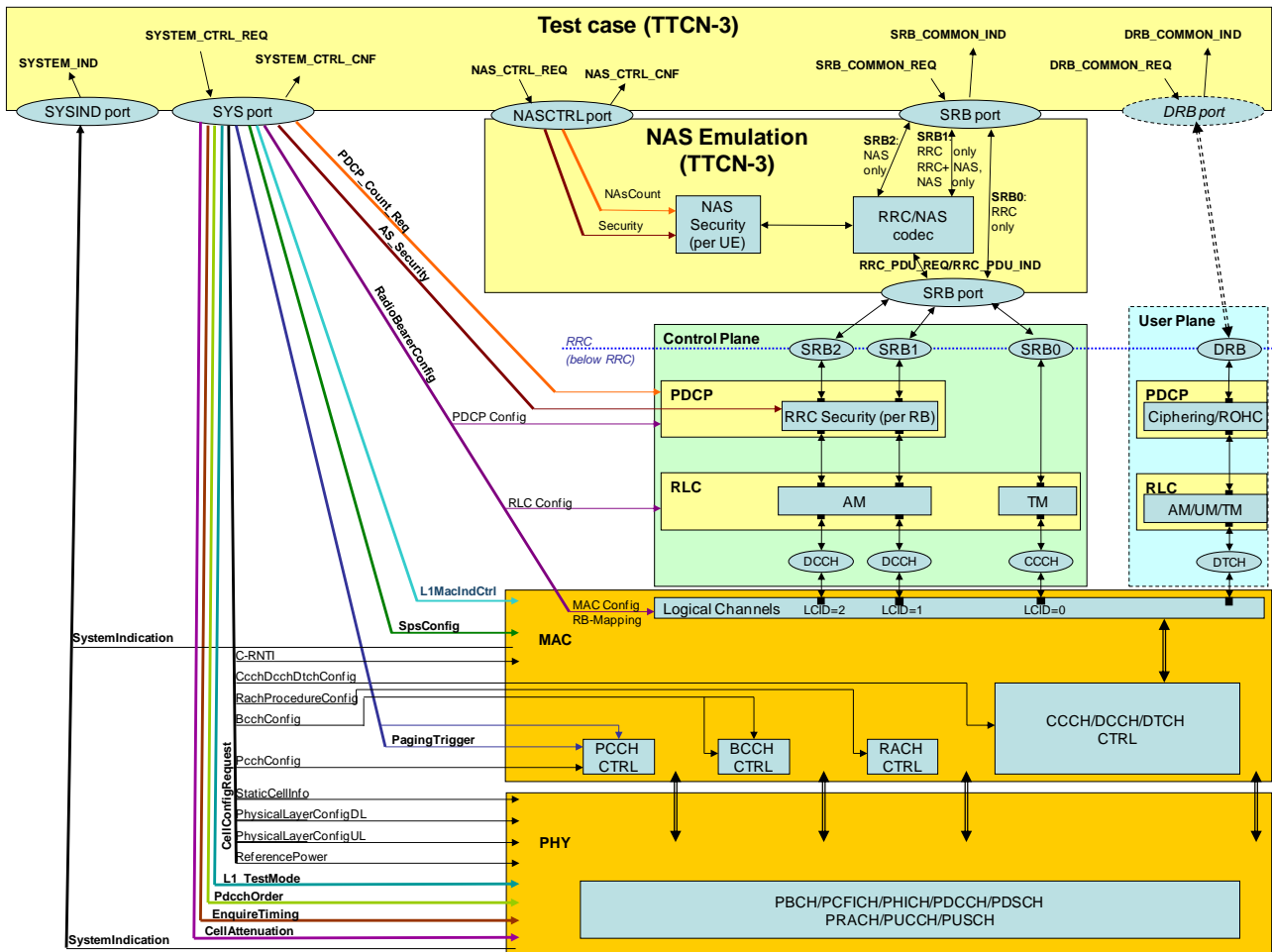

Figure 6.2-1: E-UTRAN ASP Test Model

### 6.2.1 Configuration Primitives

Annex D contains the ASP definitions for configurations.

### 6.2.2 Signalling Primitives

Annex D contains the ASP definitions for configurations.

## 6.2.3 Co-ordination Messages between NAS Emulation PTC and EUTRA PTC

TTCN-3 ASP Definition	
Type Name	SRB_COMMON_REQ
TTCN-3 Type	Record
<b>Common Part</b>	<b>TTCN-3 Type</b> record
CellId	cell id
RoutingInfo	SRB0, SRB1, SRB2
TimingInfo	system frame number and sub-frame number or "Now"
ControllInfo	CnfFlag: (normally false) FollowOnFlag: <b>true:</b> Indicates that the message(s) to be sent on the same TTI will follow NOTE 1: If the same TimingInfo is not used in the messages to be sent on the same TTI, the SS shall produce an error. <b>false:</b> Indicates that no more message(s) will follow.
<b>Signalling Part</b>	<b>TTCN-3 Type</b> record
<b>Rrc</b>	<b>TTCN-3 Type</b> union
	<b>omit:</b> NAS message shall be present; NAS message shall be sent in DLInformationTransfer <b>present, NAS message present:</b> (piggybacked) NAS PDU shall be security protected (if necessary) and inserted in RRC PDU's NAS_DedicatedInformation <b>present, NAS message omit:</b> (RRC message does not contain NAS information)
Ccch	DL_CCCH_Message as define in TS 36.331 [19], clause 6.2.1
Dcch	DL_DCCH_Message as define in TS 36.331 [19], clause 6.2.1
<b>Nas</b>	<b>TTCN-3 Type</b> record
	<b>omit:</b> RRC message shall be present; RRC message does not contain (piggybacked) NAS PDU <b>present, RRC message omit:</b> NAS message shall be sent embedded in DLInformationTransfer <b>present, RRC message present:</b> NAS message is piggybacked in RRC message NOTE 2: In case of RRC message being sent on CCCH or does not have IE NAS_DedicatedInformation NAS message shall be omitted.
SecurityProtectionInfo	security status (if protected with integrity and/or ciphering, if at all)
NAS message	union of all NAS messages define for DL except SECURITY PROTECTED NAS MESSAGE

TTCN-3 ASP Definition	
Type Name	SRB_COMMON_IND
TTCN-3 Type	Record
<b>Common Part</b>	<b>TTCN-3 Type</b> record
CellId	cell id
RoutingInfo	SRB0, SRB1, SRB2
TimingInfo	system frame number; sub-frame number when PDU has been received
<b>Signalling Part</b>	<b>TTCN-3 Type</b> record
<b>Rrc</b>	<b>TTCN-3 Type</b> union
	<b>omit:</b> NAS message shall be present; NAS message is received in ULInformationTransfer <b>present, NAS message present:</b> NAS_DedicatedInformation contains unstructured and security protected NAS PDU and the NAS message contains the deciphered message in structured format <b>present, NAS message omit:</b> (RRC message does not contain NAS information)
Ccch	UL_CCCH_Message as define in TS 36.331 [19], clause 6.2.1
Dcch	UL_DCCH_Message as define in TS 36.331 [19], clause 6.2.1

TTCN-3 ASP Definition		
Nas	TTCN-3 Type	record
	omit RRC message shall be present; RRC message does not contain (piggybacked) NAS PDU <b>present, RRC message omit</b> NAS message has been received in ULInformationTransfer <b>present, RRC message present</b> NAS message is piggybacked in RRC message	
SecurityProtectionInfo	security status (if protected with integrity and/or ciphering, if at all), nas count	
NAS message	union of all NAS messages define for UL except SECURITY PROTECTED NAS MESSAGE	

TTCN-3 ASP Definition		
Type Name	NAS_CTRL_REQ	
TTCN-3 Type	Record	
Common Part	TTCN-3 Type	record
CellId	cell id	
RoutingInfo	(not used for configuration)	
TimingInfo	current system frame number; sub-frame number (always provided by the SS)	
Result	Success or error (in case of error an SS specific error code shall be provided; this will not be evaluated by TTCN but may be useful for validation)	
Primitive specific Part	TTCN-3 Type	union
Security	Start/Restart Integrity Ciphering NasCountReset Release	
NAS Count	get set	

TTCN-3 ASP Definition		
Type Name	NAS_CTRL_CNF	
TTCN-3 Type	Record	
Common Part	TTCN-3 Type	record
CellId	cell id	
RoutingInfo	(not used for configuration)	
TimingInfo	current system frame number; sub-frame number (always provided by the SS)	
Result	Success or error (in case of error an SS specific error code shall be provided; this will not be evaluated by TTCN but may be useful for validation)	
Primitive specific Part	TTCN-3 Type	union
Security	(contains no further information)	
NAS Count	get set	

## 6.3 UTRAN ASP Definitions

The UTRAN ASP definitions are specified according to 3GPP TS 34.123 [7], clause 6A.3.

## 6.3.1 Void

## 6.3.2 ASPs for Data Transmission and Reception

TTCN-3 ASP Definition		
Type Name	U_RLC_AM_REQ	
TTCN-3 Type	union	
Port	UTRAN_AM	
RLC_AM_DATA_REQ	TS 34.123-3, clause 7.3.2.2.34	
RLC_AM_TestDataReq	TS 34.123-3, clause 7.3.3.1	

TTCN-3 ASP Definition		
Type Name	U_RLC_AM_IND	
TTCN-3 Type	union	
Port	UTRAN_AM	
RLC_AM_DATA_CNF	TS 34.123-3, clause 7.3.2.2.34	
RLC_AM_DATA_IND	TS 34.123-3, clause 7.3.2.2.34	
RLC_AM_TestDataInd	TS 34.123-3, clause 7.3.3.1	

TTCN-3 ASP Definition	Port	Defined in
UTRAN_RLC_AM_REQ	UTRAN_AM	TS 34.123-3, clause 7.3.2.2.34
UTRAN_RLC_AM_IND	UTRAN_AM	TS 34.123-3, clause 7.3.2.2.34
UTRAN_RLC_TR_REQ	UTRAN_TM	TS 34.123-3, clause 7.3.2.2.33
UTRAN_RLC_TR_IND	UTRAN_TM	TS 34.123-3, clause 7.3.2.2.33
UTRAN_RLC_UM_REQ	UTRAN_UM	TS 34.123-3, clause 7.3.2.2.35
UTRAN_RLC_UM_IND	UTRAN_UM	TS 34.123-3, clause 7.3.2.2.35
RRC_DataReq	UTRAN_Dc	TS 34.123-3, clause 7.1.2
RRC_DataReqInd	UTRAN_Dc	TS 34.123-3, clause 7.1.2

The Invalid\_DL\_DCCH\_Message type is replaced with:

Type Name	Invalid_DL_DCCH_Message
TTCN-3 Type	NULL

## 6.4 GERAN ASP Definitions

### 6.4.1 ASPs for Control Primitive Transmission

TTCN-3 ASP Definition	
Type Name	G_CPHY_CONFIG_REQ
TTCN-3 Type	Union
Port	GERAN_CL1
G_CL1_CreateCell_REQ	TS 34.123-3, clause 7.3.4.3.2.1
G_CL1_DeleteCell_REQ	TS 34.123-3, clause 7.3.4.3.2.1
G_CL1_CreateBasicPhyCh_REQ	TS 34.123-3, clause 7.3.4.3.2.1
G_CL1_CreateMultiSlotConfig_REQ	TS 34.123-3, clause 7.3.4.3.2.1
G_CL1_DeleteChannel_REQ	TS 34.123-3, clause 7.3.4.3.2.1
G_CL1_ChangePowerLevel_REQ	TS 34.123-3, clause 7.3.4.3.2.1
G_CL1_CipheringControl_REQ	TS 34.123-3, clause 7.3.4.3.2.1
G_CL1_CipherModeModify_REQ	TS 34.123-3, clause 7.3.4.3.2.1
G_CL1_ChModeModify_REQ	TS 34.123-3, clause 7.3.4.3.2.1
G_CL1_ComingFN_REQ	TS 34.123-3, clause 7.3.4.3.2.1
G_CL2_HoldPhyInfo_REQ	TS 34.123-3, clause 7.3.4.3.2.2
G_CL1_L1Header_REQ	TS 34.123-3, clause 7.3.4.3.2.1
G_CL2_MeasRptControl_REQ	TS 34.123-3, clause 7.3.4.3.2.2
G_CL2_NoUAforSABM_REQ	TS 34.123-3, clause 7.3.4.3.2.2
G_CL2_ResumeUAforSABM_REQ	TS 34.123-3, clause 7.3.4.3.2.2
G_CL2_Release_REQ	TS 34.123-3, clause 7.3.4.3.2.2
G_CL1_SetNewKey_REQ	TS 34.123-3, clause 7.3.4.3.2.1

TTCN-3 ASP Definition	
Type Name	G_CPHY_CONFIG_CNF
TTCN-3 Type	Union
Port	GERAN_CL1
ComingFN	RFN
L1Header	L1Header
None	This choice used when neither of the other choices are selected

TTCN-3 ASP Definition	
Type Name	G_CRLC_CONFIG_REQ
TTCN-3 Type	Union
Port	GERAN_CRLC
G_CRLC_CreateRLC_MAC_REQ	TS 34.123-3, clause 7.3.4.3.2.3
G_CRLC_DeleteRLC_MAC_REQ	TS 34.123-3, clause 7.3.4.3.2.3
G_CRLC_DL_TBF_Config_REQ	TS 34.123-3, clause 7.3.4.3.2.3
G_CRLC_UL_TBF_Config_REQ	TS 34.123-3, clause 7.3.4.3.2.3

TTCN-3 ASP Definition	
Type Name	G_CRLC_CONFIG_CNF
TTCN-3 Type	empty record
Port	GERAN_CRLC

TTCN-3 ASP Definition	
Type Name	G_CLLC_CONFIG_REQ
TTCN-3 Type	Union
Port	GERAN_CLLC
G_CLLC_Assign_REQ	TS 34.123-3, clause 7.3.4.3.2.4
G_CLLC_Reassign_REQ	TS 34.123-3, clause 7.3.4.3.2.4
G_CLLC_CreateLLE_REQ	TS 34.123-3, clause 7.3.4.3.2.4
G_CLLC_DeleteLLE_REQ	TS 34.123-3, clause 7.3.4.3.2.4

TTCN-3 ASP Definition	
Type Name	G_CLLC_CONFIG_CNF
TTCN-3 Type	empty record
Port	GERAN_CLLC

ASP Name	G_CSNDTCP_Activate_REQ	
PCO Type	G_CSAP	
Comments	The ASP is used to activate the SNDTCP entity	
Parameter Name	Parameter Type	Comments
sNDTCPid	SNDTCPid	The SNDTCP entity identifier of the cell
ILMEid	LLMEid	Logical link management entity Id
nSAPI	integer	The Network Service Access Point Identifier
sAPI	SAPI	LLC SAPI
PCI_Compression	INTEGER	0 - RFC 1144 [54] compress; 1 - RFC 2507 [55] compression; 32 - no compression
dataCompression	INTEGER	0 - ITU-T Recommendation V.42bis [56] compression; 1 - ITU-T Recommendation V.44 [57] compression; 32 - no compression
nPDUNumberSync	INTEGER	0 - Asynchronous 1 - Synchronous
Detailed Comments		

ASP Name	G_CSNDTCP_Activate_CNF	
PCO Type	G_CSAP	
Comments	The ASP is used to get the confirmation of a G_CSNDTCP_Activate_REQ	
Parameter Name	Parameter Type	Comments
sNDTCPid	SNDTCPid	SNDTCPentity identifier
nSAPI	NSAPI	The Network Service Access Point Identifier
Detailed Comments		

ASP Name	G_CSNDTCP_Release_REQ	
PCO Type	G_CSAP	
Comments	This ASP is used to inform that the NSAPI is in use and the acknowledge mode peer to peer LLC operation for the requested SAPI is established.	
Parameter Name	Parameter Type	Comments
sNDTCPid	SNDTCPid	The SNDTCP entity identifier
nSAPI	integer	The Network Service Access Point Identifier
Detailed Comments		

TTCN-3 ASP Definition	
Type Name	G_SNDTCP_CONFIG_CNF
TTCN-3 Type	Record
Port	GERAN_CSNDTCP

TTCN-3 ASP Definition	
Type Name	G_SNDTCP_CONFIG_REQ
TTCN-3 Type	Union
Port	GERAN_CSNDTCP
G_CSNDTCP_Activate_REQ	
G_CSNDTCP_Release_REQ	

## 6.4.2 ASPs for Data Transmission and Reception

TTCN-3 ASP Definition	
Type Name	G_L2_DATAMESSAGE_REQ
TTCN-3 Type	Union
Port	GERAN_L2
G_L2_UNITDATA_REQ	TS 34.123-3, clause 7.3.4.3.1.1
G_L2_Release_REQ	TS 34.123-3, clause 7.3.4.3.1.1
G_L2_SYSINFO_REQ	TS 34.123-3, clause 7.3.4.3.1.1
G_L2_Paging_REQ	TS 34.123-3, clause 7.3.4.3.1.1
G_L2_PagingGPRS_REQ	TS 34.123-3, clause 7.3.4.3.1.1
G_L2_DATA_REQ	TS 34.123-3, clause 7.3.4.3.1.1
G_L2_GTP_REQ	TS 34.123-3, clause 7.3.4.3.1.1

The SysInfoType is replaced with:

Type Name	SysInfoMsg
TTCN-3 Type	Union
	SYSTEMINFORMATIONTYPE1
	SYSTEMINFORMATIONTYPE2
	SYSTEMINFORMATIONTYPE3
	SYSTEMINFORMATIONTYPE4
	SYSTEMINFORMATIONTYPE5
	SYSTEMINFORMATIONTYPE6
	SYSTEMINFORMATIONTYPE13
	SYSTEMINFORMATIONTYPE15
	SYSTEMINFORMATIONTYPE2bis
	SYSTEMINFORMATIONTYPE2ter
	SYSTEMINFORMATIONTYPE2quater
	SYSTEMINFORMATIONTYPE5bis

TTCN-3 ASP Definition	
Type Name	G_L2_DATAMESSAGE_IND
TTCN-3 Type	Union
Port	GERAN_L2
G_L2_UNITDATA_IND	TS 34.123-3, clause 7.3.4.3.1.1
G_L2_Release_CNF	TS 34.123-3, clause 7.3.4.3.1.1
G_L2_Release_IND	TS 34.123-3, clause 7.3.4.3.1.1
G_L2_Estab_IND	TS 34.123-3, clause 7.3.4.3.1.1
G_L2_GTP_IND	TS 34.123-3, clause 7.3.4.3.1.1
G_L2_DATA_IND	TS 34.123-3, clause 7.3.4.3.1.1
G_L2_ACCESS_IND	TS 34.123-3, clause 7.3.4.3.1.1

TTCN-3 ASP Definition	
Type Name	G_RLC_DATAMESSAGE_REQ
TTCN-3 Type	Union
Port	GERAN_RLC
G_RLC_ControlMsg_REQ	TS 34.123-3, clause 7.3.4.3.1.2

TTCN-3 ASP Definition	
Type Name	G_RLC_DATAMESSAGE_IND
TTCN-3 Type	Union
Port	GERAN_RLC
G_RLC_ControlMsg_IND	TS 34.123-3, clause 7.3.4.3.1.2



TTCN-3 ASP Definition	
Type Name	G_LL_C_DATAMESSAGE_REQ
TTCN-3 Type	Union
Port	GERAN_LL_C
G_LL_C_UNITDATA_REQ	TS 34.123-3, clause 7.3.4.3.1.3
G_LL_C_XID_RES	TS 34.123-3, clause 7.3.4.3.1.3

ASP Name	G_LL_C_NULL_IND	
PCO Type	G_DSAP	
Comments	The ASP is used to receive the LLC NULL frame, sent by the UE for Cell Update.	
Parameter Name	Parameter Type	Comments
ILMEId	LLMEId	
tLLI	TLLI	
sAPI	SAPI	
Detailed Comments		

TTCN-3 ASP Definition	
Type Name	G_LL_C_DATAMESSAGE_IND
TTCN-3 Type	Union
Port	GERAN_LL_C
G_LL_C_UNITDATA_IND	TS 34.123-3, clause 7.3.4.3.1.3
G_LL_C_XID_IND	TS 34.123-3, clause 7.3.4.3.1.3
G_LL_C_NULL_IND	

ASP Name	G_SN_UNITDATA_REQ	
PCO Type	G_DSAP	
Comments	The ASP is used to send a valid IP datagram on the specified NSAPI to the UE/MS by unacknowledged transmission.	
Parameter Name	Parameter Type	Comments
sNDCPId	SNDCPId	
nSAPI	integer	5 to 15
n_PDU	N_PDU	Valid IPv4 or IPv6 datagram
Detailed Comments	Unacknowledged transmission mode	

ASP Name	G_SN_UNITDATA_IND	
PCO Type	G_DSAP	
Comments	The ASP is used to receive an IP datagram on the specified NASPI from the UE/MS in unacknowledged transmission mode.	
Parameter Name	Parameter Type	Comments
sNDCPId	SNDCPId	
nSAPI	integer	5 to 15
n_PDU	N_PDU	IPv4 or IPv6 datagram
Detailed Comments	Unacknowledged transmission mode	

Type Name	SNDCPId
Type Definition	INTEGER
Type Encoding	
Comments	The identifier of the SNDCP entity in SGSN

TTCN-3 ASP Definition	
Type Name	G_SN_DATAMESSAGE_REQ
TTCN-3 Type	Union
Port	GERAN_SND_C_P
G_SN_UNITDATA_REQ	

TTCN-3 ASP Definition	
Type Name	G_SN_DATAMESSAGE_IND
TTCN-3 Type	Union
Port	GERAN_SND CP
G_SN_UNITDATA_IND	