

3GPP TS 34.114 V11.3.0 (2012-12)

Technical Specification

**3rd Generation Partnership Project;
Technical Specification Group Radio Access Network;
User Equipment (UE) / Mobile Station (MS) Over The Air (OTA)
antenna performance;
Conformance testing
(Release 11)**



The present document has been developed within the 3rd Generation Partnership Project (3GPP™) and may be further elaborated for the purposes of 3GPP.

The present document has not been subject to any approval process by the 3GPP Organizational Partners and shall not be implemented. This Specification is provided for future development work within 3GPP only. The Organizational Partners accept no liability for any use of this Specification. Specifications and reports for implementation of the 3GPP™ system should be obtained via the 3GPP Organizational Partners' Publications Offices.

Keywords

UMTS, mobile station, antenna, efficiency, testing

3GPP

Postal address

3GPP support office address

650 Route des Lucioles - Sophia Antipolis
Valbonne - FRANCE
Tel.: +33 4 92 94 42 00 Fax: +33 4 93 65 47 16

Internet

<http://www.3gpp.org>

Copyright Notification

No part may be reproduced except as authorized by written permission.
The copyright and the foregoing restriction extend to reproduction in all media.

© 2012, 3GPP Organizational Partners (ARIB, ATIS, CCSA, ETSI, TTA, TTC).
All rights reserved.

Change the copyright date above as necessary.

UMTS™ is a Trade Mark of ETSI registered for the benefit of its members
3GPP™ is a Trade Mark of ETSI registered for the benefit of its Members and of the 3GPP Organizational Partners
LTE™ is a Trade Mark of ETSI currently being registered for the benefit of its Members and of the 3GPP Organizational Partners
GSM® and the GSM logo are registered and owned by the GSM Association

Contents

Foreword	9
1 Scope	9
2 References.....	10
3 Definitions, symbols, abbreviations and equations	10
3.1 Symbols.....	10
3.2 Abbreviations	11
4 General.....	12
4.1 Measurement frequencies.....	12
4.1.1 FDD frequency bands.....	12
4.1.2 GSM frequency bands	13
4.1.3 TDD frequency bands	13
5 Transmitter Performance	14
5.1 General	14
5.1.1 DUT positioning.....	14
5.1.2 Sampling grid.....	15
5.1.3 Number of independent samples (for reverberation chamber procedure)	15
5.2 Total Radiated Power (TRP) for FDD UE.....	15
5.2.1 Definition and applicability	15
5.2.2 Minimum Requirements	16
5.2.3 Test purpose.....	17
5.2.4 Method of test.....	17
5.2.4.1 Initial conditions	17
5.2.4.2 Procedure.....	17
5.2.4.3 Procedure, reverberation chamber method.....	18
5.2.5 Test requirements	18
5.3 Total Radiated Power (TRP) for GSM MS	19
5.3.1 Definition and applicability	19
5.3.2 Minimum Requirements	20
5.3.3 Test purpose.....	20
5.3.4 Method of test.....	20
5.3.4.1 Initial conditions	20
5.3.4.2 Procedure.....	21
5.3.4.3 Procedure, reverberation chamber method.....	21
5.3.5 Test requirements	22
5.4 Total Radiated Power (TRP) for TDD UE.....	22
5.4.1 Definition and applicability	22
5.4.2 Minimum Requirements	23
5.4.3 Test purpose.....	24
5.4.4 Method of test.....	24
5.4.4.1 Initial conditions	24
5.4.4.2 Procedure.....	24
5.4.4.3 Procedure, reverberation chamber method.....	25
5.4.5 Test requirements	25
5.5 Total Radiated Power (TRP) for FDD UE using LME.....	26
5.5.1 Definition and applicability	26
5.5.2 Minimum Requirements	27
5.5.3 Test purpose.....	28
5.5.4 Method of test.....	28
5.5.4.1 Initial conditions	28
5.5.4.2 Procedure.....	28
5.5.4.3 Procedure, reverberation chamber method.....	29
5.5.5 Test requirements	29
5.6 Total Radiated Power (TRP) for GSM MS using LME.....	30
5.6.1 Definition and applicability	30

5.6.2	Minimum Requirements	31
5.6.3	Test purpose.....	32
5.6.4	Method of test.....	32
5.6.4.1	Initial conditions	32
5.6.4.2	Procedure.....	32
5.6.4.3	Procedure, reverberation chamber method.....	33
5.6.5	Test requirements	33
5.7	Total Radiated Power (TRP) for TDD UE using LME.....	34
5.7.1	Definition and applicability	34
5.7.2	Minimum Requirements	35
5.7.3	Test purpose.....	35
5.7.4	Method of test.....	35
5.7.4.1	Initial conditions	35
5.7.4.2	Procedure.....	36
5.7.4.3	Procedure, reverberation chamber method.....	37
5.7.5	Test requirements	37
5.8	Total Radiated Power (TRP) for FDD UE using LEE	38
5.8.1	Definition and applicability	38
5.8.2	Minimum Requirements	39
5.8.3	Test purpose.....	39
5.8.4	Method of test.....	39
5.8.4.1	Initial conditions	39
5.8.4.2	Procedure.....	40
5.8.4.3	Procedure, reverberation chamber method.....	40
5.8.5	Test requirements	41
5.9	Total Radiated Power (TRP) for GSM MS using LEE	41
5.9.1	Definition and applicability	42
5.9.2	Minimum Requirements	42
5.9.3	Test purpose.....	43
5.9.4	Method of test.....	43
5.9.4.1	Initial conditions	43
5.9.4.2	Procedure.....	43
5.9.4.3	Procedure, reverberation chamber method.....	44
5.9.5	Test requirements	44
5.10	Total Radiated Power (TRP) for TDD UE using LEE	45
5.10.1	Definition and applicability	45
5.10.2	Minimum Requirements	46
5.10.3	Test purpose.....	46
5.10.4	Method of test.....	47
5.10.4.1	Initial conditions	47
5.10.4.2	Procedure.....	47
5.10.4.3	Procedure, reverberation chamber method.....	48
5.10.5	Test requirements	48
6	Receiver Performance	49
6.1	General	49
6.1.1	DUT Positioning	49
6.1.2	Sampling grid.....	50
6.1.3	Number of independent samples (for reverberation chamber procedure)	50
6.2	Total Radiated Sensitivity (TRS) for FDD UE	50
6.2.1	Definition and applicability	50
6.2.2	Minimum requirements.....	51
6.2.3	Test Purpose.....	52
6.2.4	Method of test.....	52
6.2.4.1	Initial conditions	52
6.2.4.2	Test procedure.....	52
6.2.4.3	Test procedure, reverberation chamber method	53
6.2.5	Test requirements	53
6.3	Total Radiated Sensitivity (TRS) for GSM MS	54
6.3.1	Definition and applicability	54
6.3.2	Minimum requirements.....	55
6.3.3	Test Purpose.....	56

6.3.4	Method of test.....	56
6.3.4.1	Initial conditions	56
6.3.4.2	Test procedure.....	56
6.3.4.3	Test procedure, reverberation chamber method	57
6.3.5	Test requirements	57
6.4	Total Radiated Sensitivity (TRS) for TDD UE.....	58
6.4.1	Definition and applicability	58
6.4.2	Minimum requirements	59
6.4.3	Test Purpose.....	59
6.4.4	Method of test.....	60
6.4.4.1	Initial conditions	60
6.4.4.2	Test procedure.....	60
6.4.4.3	Test procedure, reverberation chamber method	61
6.4.5	Test requirements	61
6.5	Total Radiated Sensitivity (TRS) for FDD UE using LME	62
6.5.1	Definition and applicability	62
6.5.2	Minimum Requirements	63
6.5.3	Test purpose.....	64
6.5.4	Method of test.....	64
6.5.4.1	Initial conditions	64
6.5.4.2	Procedure.....	64
6.5.4.3	Test procedure, reverberation chamber method	65
6.5.5	Test requirements	65
6.6	Total Radiated Sensitivity (TRS) for GSM MS using LME	66
6.6.1	Definition and applicability	66
6.6.2	Minimum requirements	67
6.6.3	Test Purpose.....	68
6.6.4	Method of test.....	68
6.6.4.1	Initial conditions	68
6.6.4.2	Test procedure.....	68
6.6.4.3	Test procedure, reverberation chamber method	69
6.6.5	Test requirements	69
6.7	Total Radiated Sensitivity (TRS) for TDD UE using LME	70
6.7.1	Definition and applicability	70
6.7.2	Minimum Requirements	71
6.7.3	Test purpose.....	72
6.7.4	Method of test.....	72
6.7.4.1	Initial conditions	72
6.7.4.2	Procedure.....	72
6.7.4.3	Test procedure, reverberation chamber method	73
6.7.5	Test requirements	73
6.8	Total Radiated Sensitivity (TRS) for FDD UE using LEE	74
6.8.1	Definition and applicability	74
6.8.2	Minimum requirements	75
6.8.3	Test Purpose.....	76
6.8.4	Method of test.....	76
6.8.4.1	Initial conditions	76
6.8.4.2	Test procedure.....	76
6.8.4.3	Test procedure, reverberation chamber method	77
6.8.5	Test requirements	77
6.9	Total Radiated Sensitivity (TRS) for GSM MS using LEE	78
6.9.1	Definition and applicability	78
6.9.2	Minimum requirements	79
6.9.3	Test Purpose.....	80
6.9.4	Method of test.....	80
6.9.4.1	Initial conditions	80
6.9.4.2	Test procedure.....	80
6.9.4.3	Test procedure, reverberation chamber method	81
6.9.5	Test requirements	81
6.10	Total Radiated Sensitivity (TRS) for TDD UE using LEE	82
6.10.1	Definition and applicability	82
6.10.2	Minimum Requirements	83

6.10.3	Test purpose.....	83
6.10.4	Method of test.....	83
6.10.4.1	Initial conditions	83
6.10.4.2	Procedure.....	84
6.10.4.3	Test procedure, reverberation chamber method	84
6.10.5	Test requirements	85
Annex A (normative): Test system characterization		86
A.1	Phantom specifications	86
A.1.1	Head Phantom.....	86
A.1.2	Laptop Ground Plane Phantom.....	86
A.2	Anechoic chamber constraints	88
A.2.1	Positioner	88
A.2.2	Measurement Antenna.....	89
A.2.3	Quiet Zone	89
A.2.4	Shielding effectiveness of the chamber	89
A.3	Reverberation chamber constraints	89
A.3.1	Positioning and mode stirring facilities	90
A.3.2	Measurement Antennas	90
A.3.3	Chamber size and characteristics	90
A.3.4	Shielding effectiveness of the chamber	91
A.4	Embedded Devices.....	91
A.4.1	Notebook.....	91
A.4.2	Tablet.....	92
Annex B (normative): Calibration		93
B.1	Calibration Procedure.....	93
B.2	Calibration Procedure – Reverberation Chamber Method.....	94
B.2.1	Measurement of S-parameters through the chamber for a complete stirring sequence.....	95
B.2.2	Calculation of the chamber reference transfer function	96
B.2.3	Cable calibration	97
Annex C (normative): Measurement Test Report		98
Annex D (normative): Maximum uncertainty of Test System and Test Tolerances		99
D.1	Maximum uncertainty of Test System	99
D.2	Test tolerances (informative).....	100
D.3	Derivation of Test Requirements (informative)	102
Annex E (normative): Estimation of Measurement Uncertainty.....		105
E.1	Mismatch uncertainty between measurement receiver and the probe antenna	111
E.2	FFS	111
E.3	Insertion loss of the probe antenna cable	111
E.4	Insertion loss of the probe antenna attenuator (if used).....	112
E.5	Insertion loss of the RF relays (if used).....	112
E.6	Influence of the antenna cable	112
E.6.1	Probe antenna cable.....	112
E.6.2	Calibration antenna cable.....	112

E.7	Absolute gain of the probe antenna.....	112
E.8	Measurement Receiver: uncertainty of absolute level.....	112
E.9	Measurement distance	112
E.9.1	Offset of DUT phase centre from axis(es) of rotation	113
E.9.2	Mutual coupling.....	113
E.9.3	Phase curvature.....	113
E.10	Quality of quiet zone	113
E.11	Tx-power drift of DUT.....	114
E.12	Uncertainty related to the use of phantom	114
E.12.1	Uncertainty from using different types of SAM phantom.....	114
E.12.2	Simulated tissue liquid uncertainty	114
E.12.3	Device Holder	114
E.12.4	Uncertainty of dielectric properties and shape of the hand phantom	115
E.12.5	Uncertainty from using different types of Laptop Ground Plane phantom.....	115
E.13	Coarse sampling grid.....	115
E.14	Random uncertainty	116
E.15	Uncertainty of network analyzer.....	116
E.16	Uncertainty of the gain/efficiency of the calibration antenna	116
E.17	Base station simulator: uncertainty of the absolute level.....	117
E.18	BER measurement: output level step resolution.....	117
E.19	Statistical uncertainty of the BER measurement	117
E.19.1	WCDMA	117
E.19.2	GSM	117
E.19.3	TD-SCDMA	118

E.20	BER normalization uncertainty	118
E.21	DUT sensitivity drift	118
E.22	Cable loss measurement uncertainty	118
E.23	Signal generator: uncertainty of the absolute output level.....	119
E.24	Signal generator: output level stability	119
E.25	Insertion loss: Calibration antenna feed cable	119
E.26	Insertion loss: Calibration antenna attenuator (if used).....	119
E.26.A	Chamber Statistical Ripple and Repeatability	119
E.26.B	Additional Power Loss in EUT Chassis	120
E.27	Examples of uncertainty budget calculations for TRP(Informative)	120
E.28	Examples of uncertainty budget calculations for TRS(Informative)	124
E.29	Examples of uncertainty budget calculations for TRP, reverberation chamber method (Informative)	128
E.30	Examples of uncertainty budget calculations for TRS, reverberation chamber method (Informative)	131
	Annex F (informative): Suggested Recipes of Liquid to be used inside SAM Phantom.....	132
	Annex G (informative): Anechoic Chamber Specifications and Validation Method	133
G.1	Shielded anechoic chamber specifications	133
G.2	Quiet Zone reflectivity level validation	133
G.2.1	Description of a practical method for Quiet Zone characterization	133
G.3	FFS	134
G.4	Standard deviation of electric field	134
	Annex G.A (informative): Reverberation Chamber Specifications and Validation Method.....	135
G.A.1	Shielded reverberation chamber specifications	135
G.A.2	Reverberation chamber statistical ripple and repeatability validation	135
	Annex H (informative): Recommended performance	136
H.1	General.....	136
H.2	Total Radiated Power	137
H.3	Total Radiated Sensitivity	139
	Annex I (informative): Bibliography	142
	Annex J (informative): Change history	144

Foreword

This Technical Specification has been produced by the 3rd Generation Partnership Project (3GPP).

The contents of the present document are subject to continuing work within the TSG and may change following formal TSG approval. Should the TSG modify the contents of the present document, it will be re-released by the TSG with an identifying change of release date and an increase in version number as follows:

Version x.y.z

where:

- x the first digit:
 - 1 presented to TSG for information;
 - 2 presented to TSG for approval;
 - 3 or greater indicates TSG approved document under change control.
- y the second digit is incremented for all changes of substance, i.e. technical enhancements, corrections, updates, etc.
- z the third digit is incremented when editorial only changes have been incorporated in the document.

1 Scope

The present document describes the test procedure for the radiated performances measurements of the 3G/2G user equipment/mobile stations (UE/MS) in active mode in both the uplink and the downlink. The FDD UE test procedure is based on the test method developed as a result of COST 273 Sub-Working Group (SWG) 2.2 members' contributions. Background work has also been made in the former COST259 project. The TDD UE test procedure is based on the test method developed as a result of CCSA TC9 WG1 members' contributions. Background work has been made in the former CCSA TC9 project.

The measurement procedure explained in this document applies to UE/MS used under the "speech mode" conditions that correspond to predefined positions for voice application when the handset is held close to the user's head. This method is also applicable to free space measurements for UE/MS devices. The data transfer position (free space) explained in this document applies when the UE is used away from the user's head. For LME and LEE devices free space configuration without head and hand phantoms is applicable. Free space measurements are applicable to devices used in the data transfer position that consist of the laptop mounted equipment (LME) plug-in UEs and laptop embedded equipment (LEE) UEs.

The tests apply to UEs and laptops using single or multiple receive antennas. For GSM technology this is applicable to all MSs and for 3G technology this is applicable to "one antenna" UEs and "RxDiversity" UEs.

The testing methodology applies to any single or multi-mode (GSM / UMTS / TD-SCDMA) terminals.

The radio tests considered here are:

1. The measurement of the Total Radiated Power (TRP)
2. The measurement of the Total Radiated Sensitivity (TRS)

The test procedure described in this document measures the performance of the transmitter and the receiver, including the antenna and also the effects of the user.

The major parts of this test procedure are based on the 3-D pattern measurement method. It has been considered necessary to define some items and components in the test procedure in detail, such as test channels and phantom set-ups, in order to make the testing in different laboratories harmonized. The procedure is, however, not limited to some specific antenna chambers or positioners.

2 References

The following documents contain provisions which, through reference in this text, constitute provisions of the present document.

- References are either specific (identified by date of publication, edition number, version number, etc.) or non-specific.
- For a specific reference, subsequent revisions do not apply.
- For a non-specific reference, the latest version applies. In the case of a reference to a 3GPP document (including a GSM document), a non-specific reference implicitly refers to the latest version of that document *in the same Release as the present document*.

- [1] 3GPP TR 25.914 Technical Specification 3rd Generation Partnership Project; Technical Specification Group Radio Access Networks; Measurements of Radio Performances for UMTS Terminals in Speech Mode
- [2] 3GPP TS 25.101 Technical Specification 3rd Generation Partnership Project; Technical Specification Group Radio Access Networks; User Equipment (UE) radio transmission and reception (FDD)
- [3] 3GPP 34.121, 3rd Generation Partnership Project; Technical Specification Group Terminals; Terminal conformance specification; Radio transmission and reception (FDD)
- [4] ETSI TR 100 028, Paragraph D.1.3.6
- [5] ETSI TR 102 273-1-2
- [6] ETSI TR 102 273-1-1
- [7] 3GPP TR 21.905 "Vocabulary for 3GPP Specifications"
- [8] 3GPP TR 25.990 "Vocabulary"
- [9] 3GPP TS 51.010-1 " Mobile Station (MS) conformance specification; Part 1: Conformance specification "
- [10] 3GPP TS 34.108 "Common Test Environments for User Equipment (UE) Conformance Testing".
- [11] 3GPP TS 34.109 "Terminal logical test interface; Special conformance testing functions
- [12] 3GPP TS 25.144 "User Equipment (UE) and Mobile Station (MS) over the air performance requirements"
- [13] 3GPP TS 34.122 " Terminal conformance specification; Radio transmission and reception (TDD) "

3 Definitions, symbols, abbreviations and equations

For the purposes of the present document, the terms and definitions given in 3GPP TR 21.905 [7], 3GPP TR 25.990 [8] and the following apply:

3.1 Symbols

For the purposes of the present document, the following symbols apply:

θ	Zenith angle in the spherical co-ordinate system
ϕ	Azimuth angle in the spherical co-ordinate system
Ω	Solid angle defined at the phase centre of the DUT
$G_{\psi}(\theta, \phi, f)$	Antenna gain pattern in the ψ -polarization as function of the spherical co-ordinates and the carrier frequency

F	Carrier frequency
P_{tr}	Transmitted power
$Q_{\psi}(\theta, \phi, f)$	Angular power distribution in the ψ -polarization as function of the spherical co-ordinates and the carrier frequency
dB	decibel
dBm	dB referenced to one milliwatt
m	meter
mm	millimeter
kbps	kilobit per second
ms	millisecond
MHz	megahertz

3.2 Abbreviations

For the purposes of the present document, the following abbreviations apply:

3G	3 rd Generation
3GPP	3G Partnership Project
3-D	Three Dimensional
AAU	Aalborg University
APD	Angular Power Distribution
ARFCN	Absolute Radio Frequency Channel Number
BER	Bit Error Ratio
BS	Base Station
BT	Bluetooth
CN	Core Network
CPICH RSCP	Common Pilot Channel Received Signal Code Power
CRC	Cyclic Redundancy Check
DCH	Dedicated Channel
DL	Downlink
DPCH	Dedicated Physical Channel
DPDCH	Dedicated Physical Data Channel
DPCCH	Physical Control Channel
DTCH	Dedicated Traffic Channel
DUT	Device Under Test
EIRP	Effective Isotropic Radiated Power
EIS	Effective Isotropic Sensitivity
ETSI	European Telecommunications Standards Institute
FDD	Frequency Division Duplex
FS	Free Space
GPS	Global Positioning System
GSM	Global System for Mobile communications
HUT	Helsinki University of Technology
LEE	Laptop Embedded Equipment (e.g. embedded module card embedded in notebooks)
LME	Laptop Mounted Equipment (e.g., plug-in devices like USB dongles)
MS	Mobile Station
NB	Node B
NSA	Normalised Site Attenuation
OTA	Over The Air
QoS	Quality of Service
QPSK	Quadrature Phase Shift Keying (modulation)
RAB	Radio Access Bearer
RB	Radio Bearer
RAN	Radio Access Network
RBW	Resolution Bandwidth
RF	Radio Frequency
RMS	Root Mean Square
Rx	Receiver
SAM	Specific Anthropomorphic Mannequin
SS	System Simulator
TDD	Time Division Duplex

TFCI	Transport Format Combination Indicator
Tx	Transmitter
TRP	Total Radiated Power
TRS	Total Radiated Sensitivity (also: Total Isotropic Sensitivity)
USB	Universal Serial Bus
UTRA	UMTS Terrestrial Radio Access
XPD	Cross-Polar Discrimination of the antenna
XPR	Cross-Polarization ratio of the channel
UDP	User Datagram Protocol
UL	Uplink
UE	User Equipment
UMTS	Universal Mobile Telecommunications System
VBW	Video Bandwidth

4 General

The present document describes test procedure for the radiated performances measurements of the 3G/2G user equipment/mobile stations (UE/MS) in active mode in both the up- and the downlink. The test procedure is based on 3GPP TR 25.914 [1].

4.1 Measurement frequencies

The radiation patterns of handset antennas can be expected to be frequency dependent, both in the size and, to smaller extent, in the shape of the pattern. TRP and TRS shall be measured in 3 channels in a frequency band, i.e. low, mid and high channels.

4.1.1 FDD frequency bands

UTRA/FDD is designed to operate in the following paired bands:

Table 4.1: UTRA FDD frequency bands

Operating Band	UL Frequencies UE transmit, Node B receive	DL frequencies UE receive, Node B transmit
I	1920 – 1980 MHz	2110 –2170 MHz
II	1850 –1910 MHz	1930 –1990 MHz
III	1710-1785 MHz	1805-1880 MHz
IV	1710-1755 MHz	2110-2155 MHz
V	824 – 849 MHz	869-894 MHz
VI	830-840 MHz	875-885 MHz
VII	2500-2570 MHz	2620-2690 MHz
VIII	880 – 915 MHz	925 – 960 MHz
IX	1749.9-1784.9 MHz	1844.9-1879.9 MHz
X	1710 – 1770 MHz	2110 – 2170 MHz
XIX	830 – 845MHz	875 – 890 MHz

Table 4.2: UTRA FDD Channels

Operating Band	UL Channels			DL Channels		
	Low	Mid	High	Low	Mid	High
I	9612	9750	9888	10562	10700	10838
II	9262	9400	9538	9662	9800	9938
III	937	1113	1288	1162	1338	1513
IV	1312	1413	1513	1537	1638	1738
V	4132	4183	4233	4357	4408	4458
VI	4162	4175	4188	4387	4400	4413
VII	2012	2175	2338	2237	2400	2563
VIII	2712	2788	2863	2937	3013	3088
IX	8762	8837	8912	9237	9312	9387
X	2888	3025	3162	3113	3250	3387
XIX	387	412	437	787	812	837

NOTE: Deployment in other frequency bands is not precluded.

4.1.2 GSM frequency bands

Table 4.3: GSM frequency bands

Operating Band	UL Frequencies MS transmit, BTS receive	DL frequencies MS receive, BTS transmit
GSM 850	824 – 849 MHz	869-894 MHz
P-GSM 900	890 – 915 MHz	935 – 960 MHz
E-GSM 900	880 – 915 MHz	925 – 960 MHz
DCS 1800	1710-1785 MHz	1805-1880 MHz
PCS 1900	1850 –1910 MHz	1930 –1990 MHz

Table 4.4: GSM Channels

Operating Band	Channels		
	Low	Mid	High
GSM 850	128	190	251
P-GSM 900	1	62	124
E-GSM 900	975	38	124
DCS 1800	512	699	885
PCS 1900	512	661	810

4.1.3 TDD frequency bands

UTRA/TDD is designed to operate in the following bands:

Table 4.5: UTRA TDD frequency bands

Operating Band	Frequencies
a	1900-1920 MHz 2010-2025 MHz
b*	1850-1910 MHz 1930-1990 MHz
c*	1910-1930 MHz
d**	2570-2620 MHz
e	2300-2400 MHz
f	1880-1920 MHz

NOTE: Deployment in other frequency bands is not precluded.

* Used in ITU Region 2

** Used in ITU Region 1

Table 4.6: UTRA TDD Channels

Operating Band	Channels		
	Low	Mid	High
a 1900-1920 MHz 2010-2025 MHz	9504 10054	9550 10087	9596 10121
b 1850-1910 MHz 1930-1990 MHz	9254 9654	9400 9800	9546 9946
c 1910-1930 MHz	9554	9600	9646
d 2570-2620 MHz	12854	12975	13096
e 2300-2400 MHz	11504	11750	11996
f 1880-1920 MHz	9404	9500	9596

5 Transmitter Performance

5.1 General

This section specifies the test method and test requirements for the radiated power measurement. There are two methods described. The main method is based on an anechoic chamber approach and the alternative method is based on a reverberation chamber approach.

5.1.1 DUT positioning

The DUT positioning on head phantom means that the measurements are performed so that the DUT is placed against a SAM phantom. The characteristics of the SAM phantom are specified in Annex A.1.1. The DUT is attached to the SAM phantom in “cheek” position as defined in IEEE Std 1528. The DUT performance is measured on left and right side of the head.

The DUT positioning on laptop ground plane phantom means that a laptop ground plane phantom is used for radiated performance measurements in case of plug-in DUT like USB dongles that is used away from the user’s head. The DUT is connected to the USB connector of the laptop ground plane phantom. The characteristics of the laptop ground plane phantom are specified in Annex A.1.2. The objective of the laptop ground plane phantom is to reproduce the effects of the ground plane for the antenna of the DUT while avoiding the variation of the measurements introduced by a real

laptop. The DUT shall be plugged into the USB connector and positioned in accordance with the manufacturer recommended primary mechanical mode. In the absence of such a recommendation the DUT with either the rotary USB porter or non-rotary USB porter should be horizontally plugged into the horizontal USB connector.

The DUT positioning in a free space configuration without head and hand phantoms as specified in Annex A.4 is used for radiated performance measurements in case of embedded module card that is used away from the user's head.

5.1.2 Sampling grid

A 15°-sample grid in both azimuth and elevation can be considered sufficient for accurate measurements. Generally it can be said that since the radiating object has a limited size the gain pattern cannot change arbitrarily versus angle, and therefore only a limited number of samples are required to represent the gain pattern to a given accuracy.

Alternatively, different sampling patterns may be used, if they are able to ensure same or greater accuracy. The TRP can be calculated by interpolating the values to points on the regular grid. If an alternative sampling pattern is used number of measurement points should be greater than in the regular sampling grid.

5.1.3 Number of independent samples (for reverberation chamber procedure)

When measuring the TRP in an isotropic Rayleigh fading environment, 100 independent samples can be considered sufficient for ensuring an expanded accuracy better than 0.5 dB.

5.2 Total Radiated Power (TRP) for FDD UE

5.2.1 Definition and applicability

The Total Radiated Power (TRP) is a measure of how much power the DUT actually radiates. The TRP is defined as the integral of the power transmitted in different directions over the entire radiation sphere:

$$TRP = \frac{1}{4\pi} \int (EIRP_{\theta}(\Omega; f) + EIRP_{\varphi}(\Omega; f)) d\Omega$$

Where Ω is the solid angle describing the direction, f is frequency. θ and φ are the orthogonal polarizations.

$EIRP_{\theta}$ and $EIRP_{\varphi}$ are the actually transmitted power-levels in corresponding polarizations.

Thus

$$TRP \approx \frac{\pi}{2NM} \sum_{n=0}^{N-1} \sum_{m=0}^{M-1} [EIRP_{\theta}(\theta_n, \varphi_m; f) + EIRP_{\varphi}(\theta_n, \varphi_m; f)] \sin(\theta_n)$$

In these formulas N and M are the number of sampling intervals for theta and phi. θ_n and φ_m are the measurement angles. The sampling intervals are discussed further in Section 5.1.2.

The TRP can also be calculated from Rayleigh faded samples of the total power transmitted from the UE/MS. The measurement of transmitter performance in an isotropic Rayleigh fading environment is based on sampling the radiated power of the UE/MS for a discrete number of field combinations in the chamber. The average value of these statistically distributed samples is proportional to the TRP and by calibrating the average power transfer function, an absolute value of the TRP can be obtained. Thus

$$TRP \approx \frac{\sum_{n=1}^N \left(\frac{P_n}{C_n (1 - R_n)} \right)}{\sum_{n=1}^N P_{ref,n}}$$

where $P_{ref,n}$ is the reference power transfer function for fixed measurement antenna n, R_n is the reflection coefficient for fixed measurement antenna n and C_n is the path loss in the cables connecting the measurement receiver to fixed measurement antenna n. These parameters are calculated from the calibration measurement and are further discussed in Annex B.2. P_n is the average power measured by fixed measurement antenna n and can be calculated using the following expression:

$$P_n = \frac{\sum_{m=1}^M |S_{21,n,m}|^2}{M}$$

where $S_{21,n,m}$ is sample number m of the complex transfer function measured with fixed measurement antenna n and M is the total number of samples measured for each fixed measurement antenna.

Note that all averaging must be performed using linear power values (e.g. measurements in Watts).

The requirements and this test apply to all types of UTRA for the FDD UE for Release 7 and later releases.

5.2.2 Minimum Requirements

The average TRP of low, mid and high channel in beside head position shall be higher than minimum performance requirements for roaming bands shown in Table 5.2.1. The averaging shall be done in linear scale for the TRP results of both right and left side of the phantom head.

$$TRP_{average} = 10 \log \left[\frac{10^{P_{left_low}/10} + 10^{P_{left_mid}/10} + 10^{P_{left_high}/10} + 10^{P_{right_low}/10} + 10^{P_{right_mid}/10} + 10^{P_{right_high}/10}}{6} \right]$$

In addition the minimum TRP of each measured channel in beside head position shall be higher than minimum performance requirements shown in the columns "Min".

$$TRP_{min} = \min [P_{left_low}, P_{left_mid}, P_{left_high}, P_{right_low}, P_{right_mid}, P_{right_high}]$$

Table 5.2.1 TRP minimum performance requirement for FDD roaming bands in the speech position and the primary mechanical mode

Operating band	Power Class 1	Power Class 2	Power Class 3		Power Class 3bis		Power Class 4	
	Power (dBm)	Power (dBm)	Power (dBm)		Power (dBm)		Power (dBm)	
			Average	Min	Average	Min	Average	Min
I	-	-	+15	+13	+15	+13	+13	+11
II	-	-	+15	+13	+15	+13	+13	+11
III	-	-	+15	+13	+15	+13	+13	+11
IV	-	-	+15	+13	+15	+13	+13	+11
V	-	-	+11	+9	+11	+9	+9	+7
VI	-	-	+11	+9	+11	+9	+9	+7
VII	-	-	+15	+13	+15	+13	+13	+11
VIII	-	-	+12	+10	+12	+10	+10	+8
IX	-	-	+15	+13	+15	+13	+13	+11
XIX	-	-	+11.5	+9.5	+11.5	+9.5	+9.5	+7.5

NOTE: Applicable for dual-mode GSM/UMTS.

The normative reference for this clause is TS25.144 section 6.1.1.1.

5.2.3 Test purpose

The purpose of this test is to verify that $TRP_{average}$ and TRP_{min} of the UE is not below specified values. A lower $TRP_{average}$ and TRP_{min} decrease the coverage area.

5.2.4 Method of test

5.2.4.1 Initial conditions

The output power is a measure of the maximum power the UE can transmit in a bandwidth of at least $(1 + \alpha)$ times the chip rate of the radio access mode, for more information see 3GPP TS 34.121 chapter 5.2. The period of measurement shall be at least one timeslot. Also care should be taken that the noise floor of the measurement receiver is not disturbing the power measurement.

Test environment: normal; see TS34.121-1 [3] clause G.2.1.

Frequencies to be tested: low range, mid range, high range; see TS34.121-1 [3] clause G.2.4.

- 1) Set the SS downlink physical channels according to settings in Table 5.2.2. Set the DPCH power such that there will not be transmission gaps due to too low signal strength throughout the measurement.
- 2) Power on the UE.
- 3) A call is set up according to the Generic call setup procedure. The power control algorithm shall be set to Power Control Algorithm 2. Compressed mode shall be set to OFF.
- 4) Enter the UE into loopback test mode 2 and start the loopback test.

See TS 34.108 [10] and TS 34.109 [11] for details regarding generic call setup procedure and loopback test.

Table 5.2.2: Downlink Physical Channels transmitted during a connection

Physical Channel	Power
CPICH	CPICH_Ec / DPCH_Ec = 7 dB
P-CCPCH	P-CCPCH_Ec / DPCH_Ec = 5 dB
SCH	SCH_Ec / DPCH_Ec = 5 dB
PICH	PICH_Ec / DPCH_Ec = 2 dB
DPCH	Test dependent power

5.2.4.2 Procedure

- 1) Send continuously Up power control commands to the UE.
- 2) As the UE reaches maximum power, start sending PN15 data pattern.
- 3) Position the UE against the SAM phantom
- 4) Measure the $EIRP_{\theta}$ and $EIRP_{\phi}$ with a sample step of 15° in theta (θ) and phi (ϕ) directions using a test system having characteristics as described in Annex A.
- 5) Calculate TRP using equations from chapter 5.2.1

NOTE 1: The measurement procedure is based on the measurement of the spherical radiation pattern of the DUT. The power radiated by the DUT is sampled in far field in a group of points located on a spherical surface enclosing the DUT. The EIRP samples are taken using a constant sample step of 15° both in theta (θ) and phi (ϕ) directions. In some cases a different sampling grid may be used to speed up the measurements (See Section 5.1.2). All the EIRP samples are taken with two orthogonal polarizations, θ - and ϕ - polarisations.

NOTE 2: The noise floor of the measurement receiver shall not disturb the power measurement.

NOTE 3: Non Standard settings: To speed up sensitivity measurements, power measurements may be done with non standard modulation. However to obtain TRP result the measured EIRP figures shall be normalized by

$$\overline{\Delta EIRP} = \frac{1}{n} \sum_{i=1}^n (EIRP_{std_i} - EIRP_{nstd_i})$$

where $EIRP_{std_i}$ is power measurement done with standard setting. $EIRP_{nstd_i}$ is power measurement done with non standard modulation. n is amount of reference measurement points.

To ensure accuracy of TRP, the amount of reference points measured should be at least 4. It is recommended to spread the reference measurements equally during the measurement time.

5.2.4.3 Procedure, reverberation chamber method

- 1) Send continuously Up power control commands to the UE.
- 2) As the UE reaches maximum power, start sending PN15 data pattern.
- 3) Position the UE against the SAM phantom
- 4) Measure a sufficient number of independent samples (see section 5.1.3) of $S_{21,n,m}$ using a test system having characteristics as described in Annex A.
- 5) Calculate TRP using equations from section 5.2.1.

NOTE 1: The measurement procedure is based on the measurement of the total power radiated from the UE/MS to a full 3 dimensional isotropic environment with uniform elevation and azimuth field distribution. The power transmitted by the DUT is undergoing Rayleigh fading and is sampled by the fixed measurement antennas. Moreover, it is important that the samples collected are independent, in order to get sufficient accuracy of the estimated TRP value.

NOTE 2: The noise floor of the measurement receiver shall not disturb the power measurement.

5.2.5 Test requirements

The average TRP of low, mid and high channel in beside head position shall be higher than test performance requirements for roaming bands shown in Table 5.2.3. The averaging shall be done in linear scale for the TRP results of both right and left side of the phantom head.

$$TRP_{average} = 10 \log \left[\frac{10^{P_{left_low}/10} + 10^{P_{left_mid}/10} + 10^{P_{left_high}/10} + 10^{P_{right_low}/10} + 10^{P_{right_mid}/10} + 10^{P_{right_high}/10}}{6} \right]$$

In addition the minimum TRP of each measured channel in beside head position shall be higher than minimum performance requirements shown in the columns "Min".

$$TRP_{min} = \min [P_{left_low}, P_{left_mid}, P_{left_high}, P_{right_low}, P_{right_mid}, P_{right_high}]$$

Table 5.2.3 TRP test requirement for FDD roaming bands in the speech position and the primary mechanical mode

Operating band	Power Class 1	Power Class 2	Power Class 3		Power Class 3bis		Power Class 4	
	Power (dBm)	Power (dBm)	Power (dBm)		Power (dBm)		Power (dBm)	
			Average	Min	Average	Min	Average	Min

I	-	-	+14.3	+12.0	+14.3	+12.0	+12.3	+10.0
II	-	-	+14.3	+12.0	+14.3	+12.0	+12.3	+10.0
III	-	-	+14.3	+12.0	+14.3	+12.0	+12.3	+10.0
IV	-	-	+14.3	+12.0	+14.3	+12.0	+12.3	+10.0
V	-	-	+10.3	+8.0	+10.3	+8.0	+8.3	+6
VI	-	-	+10.3	+8.0	+10.3	+8.0	+8.3	+6
VII	-	-	+14.3	+12.0	+14.3	+12.0	+12.3	+10.0
VIII	-	-	+11.3	+9.0	+11.3	+9.0	+9.3	+7
IX	-	-	+14.3	+12.0	+14.3	+12.0	+12.3	+10.0
XIX	-	-	+10.8	+8.5	+10.8	+8.5	+8.8	+6.5
NOTE:	Applicable for dual-mode GSM/UMTS.							

NOTE: If the above Test Requirement differs from the Minimum Requirement then the Test Tolerance applied for this test is non-zero. The Test Tolerance for this test is defined and the explanation of how the Minimum Requirement has been relaxed by the Test Tolerance is given in Annex D.

5.3 Total Radiated Power (TRP) for GSM MS

5.3.1 Definition and applicability

The Total Radiated Power (TRP) is a measure of how much power the DUT actually radiates. The TRP is defined as the integral of the power transmitted in different directions over the entire radiation sphere:

$$TRP = \frac{1}{4\pi} \oint (EIRP_{\theta}(\Omega; f) + EIRP_{\varphi}(\Omega; f)) d\Omega$$

Where Ω is the solid angle describing the direction, f is frequency. θ and φ are the orthogonal polarizations.

$EIRP_{\theta}$ and $EIRP_{\varphi}$ are the actually transmitted power-levels in corresponding polarizations.

Thus

$$TRP \approx \frac{\pi}{2NM} \sum_{n=0}^{N-1} \sum_{m=0}^{M-1} [EIRP_{\theta}(\theta_n, \varphi_m; f) + EIRP_{\varphi}(\theta_n, \varphi_m; f)] \sin(\theta_n)$$

In these formulas N and M are the number of sampling intervals for theta and phi. θ_n and φ_m are the measurement angles. The sampling intervals are discussed further in Section 5.1.2.

The TRP can also be calculated from Rayleigh faded samples of the total power transmitted from the UE/MS. The measurement of transmitter performance in an isotropic Rayleigh fading environment is based on sampling the radiated power of the UE/MS for a discrete number of field combinations in the chamber. The average value of these statistically distributed samples is proportional to the TRP and by calibrating the average power transfer function, an absolute value of the TRP can be obtained. Thus

$$TRP \approx \frac{\sum_{n=1}^N \left(\frac{P_n}{C_n (1 - R_n)} \right)}{\sum_{n=1}^N P_{ref,n}}$$

where $P_{ref,n}$ is the reference power transfer function for fixed measurement antenna n , R_n is the reflection coefficient for fixed measurement antenna n and C_n is the path loss in the cables connecting the measurement receiver to fixed measurement antenna n . These parameters are calculated from the calibration measurement and are further discussed in Annex B.2. P_n is the average power measured by fixed measurement antenna n and can be calculated using the following expression:

$$P_n = \frac{\sum_{m=1}^M |S_{21,n,m}|^2}{M}$$

where $S_{21,n,m}$ is sample number m of the complex transfer function measured with fixed measurement antenna n and M is the total number of samples measured for each fixed measurement antenna.

The requirements and this test apply to all types of MS that support GSM for Release 7 and later releases.

5.3.2 Minimum Requirements

The average TRP of low, mid and high channel in beside head position shall be higher than minimum performance requirements for roaming bands shown in Table 5.3.1. The averaging shall be done in linear scale for the TRP results of both right and left side of the phantom head.

$$TRP_{average} = 10 \log \left[\frac{10^{P_{left_low}/10} + 10^{P_{left_mid}/10} + 10^{P_{left_high}/10} + 10^{P_{right_low}/10} + 10^{P_{right_mid}/10} + 10^{P_{right_high}/10}}{6} \right]$$

In addition the minimum TRP of each measured channel in beside head position shall be higher than minimum performance requirements shown in the columns "Min".

$$TRP_{min} = \min [P_{left_low}, P_{left_mid}, P_{left_high}, P_{right_low}, P_{right_mid}, P_{right_high}]$$

Table 5.3.1: TRP minimum requirement for GSM roaming bands in the speech position and the primary mechanical mode

Operating band	Power Class 1		Power Class 2		Power Class 3		Power Class 4		Power Class 5	
	Power (dBm)		Power (dBm)		Power (dBm)		Power (dBm)		Power (dBm)	
	Average	Min	Average	Min	Average	Min	Average	Min	Average	Min
GSM 850							19.5	17.5		
GSM 900							20.5	18.5		
DCS 1800	21	19								
PCS 1900	21	19								

Note: applicable for dual-mode GSM/UMTS.

The normative reference for this clause is TS25.144 section 6.1.1.2.

5.3.3 Test purpose

The purpose of this test is to verify that $TRP_{average}$ and TRP_{min} of the MS is not below specified values. A lower $TRP_{average}$ and TRP_{min} decrease the coverage area.

5.3.4 Method of test

5.3.4.1 Initial conditions

A call is set up by the SS according to the generic call set up procedure on a channel with ARFCN in the Mid ARFCN range, power control level set to Max power. MS TXPWR_MAX_CCH is set to the maximum value supported by the Power Class of the Mobile under test.

The SS sends Standard Test Signal C1; see TS51.010-1 [9] Annex A5.2.

The downlink power is set such that there will not be transmission gaps due to too low signal strength throughout the measurement

Test environment: normal condition; see TS51.010-1 [9] Annex A1.2.2.

5.3.4.2 Procedure

- 1) Position the MS against the SAM phantom
- 2) Measure the $EIRP_{\theta}$ and $EIRP_{\phi}$ with a sample step of 15° in theta (θ) and phi (ϕ) directions using a test system having characteristics as described in Annex A.
- 3) Calculate TRP using equations from chapter 5.3.1
- 4) Test steps 1 to 3 is repeated for ARFCN in the low and high range

NOTE 1: Measurement of normal burst transmitter output power. The SS takes power measurement samples evenly distributed over the duration of one burst with a sampling rate of at least $2/T$, where T is the bit duration. The samples are identified in time with respect to the modulation on the burst. The SS identifies the centre of the useful 147 transmitted bits, i.e. the transition from bit 13 to bit 14 of the midamble, as the timing reference

NOTE 2: The measurement procedure is based on the measurement of the spherical radiation pattern of the DUT. The power radiated by the DUT is sampled in far field in a group of points located on a closed surface enclosing the DUT. The EIRP samples are taken using a constant sample step of 15° both in theta (θ) and phi (ϕ) directions. In some cases a different sampling grid can be used to speed up the measurements (See Section 5.1.2). All the EIRP samples are taken with two orthogonal polarizations, θ - and ϕ - polarisations.

NOTE 3: The noise floor of the measurement receiver shall not disturb the power measurement.

NOTE 4: Non Standard settings: To speed up sensitivity measurements, power measurements can be done with non standard modulation. However to obtain TRP result the measured EIRP figures shall be normalized by

$$\Delta \overline{EIRP} = \frac{1}{n} \sum_{i=1}^n (EIRP_{std_i} - EIRP_{nstd_i})$$

where $EIRP_{std_i}$ is power measurement done with standard setting. $EIRP_{nstd_i}$ is power measurement done with non standard modulation. n is amount of reference measurement points.

To ensure accuracy of TRP, the amount of reference points measured should be at least 4. It is recommended to spread the reference measurements equally during the measurement time.

5.3.4.3 Procedure, reverberation chamber method

- 1) Position the UE against the SAM phantom
- 2) Measure a sufficient number of independent samples (see section 5.1.3) of $S_{21,n,m}$ using a test system having the characteristics described in Annex A.
- 3) Calculate TRP using equations from section 5.3.1.
- 4) Test steps 1 to 3 is repeated for ARFCN in the low and high range

NOTE 1: Measurement of normal burst transmitter output power. The SS takes power measurement samples evenly distributed over the duration of one burst with a sampling rate of at least $2/T$, where T is the bit duration. The samples are identified in time with respect to the modulation on the burst. The SS identifies the centre of the useful 147 transmitted bits, i.e. the transition from bit 13 to bit 14 of the midamble, as the timing reference

NOTE 2: The measurement procedure is based on the measurement of the total power radiated from the UE/MS to a full 3 dimensional isotropic environment with uniform elevation and azimuth field distribution. The power transmitted by the DUT is undergoing Rayleigh fading and is sampled by the fixed measurement antennas. Moreover, it is important that the samples collected are independent, in order to get sufficient accuracy of the estimated TRP value.

NOTE 3: The noise floor of the measurement receiver shall not disturb the power measurement.

5.3.5 Test requirements

The average TRP of low, mid and high channel in beside head position shall be higher than test performance requirements for roaming bands shown in Table 5.3.2. The averaging shall be done in linear scale for the TRP results of both right and left side of the phantom head.

$$TRP_{average} = 10 \log \left[\frac{10^{P_{left_low}/10} + 10^{P_{left_mid}/10} + 10^{P_{left_high}/10} + 10^{P_{right_low}/10} + 10^{P_{right_mid}/10} + 10^{P_{right_high}/10}}{6} \right]$$

In addition the minimum TRP of each measured channel in beside head position shall be higher than minimum performance requirements shown in the columns “Min”.

$$TRP_{min} = \min [P_{left_low}, P_{left_mid}, P_{left_high}, P_{right_low}, P_{right_mid}, P_{right_high}]$$

Table 5.3.2: TRP test requirement for GSM roaming bands in the speech position and the primary mechanical mode

Operating band	Power Class 1		Power Class 2		Power Class 3		Power Class 4		Power Class 5	
	Power (dBm)		Power (dBm)		Power (dBm)		Power (dBm)		Power (dBm)	
	Average	Min	Average	Min	Average	Min	Average	Min	Average	Min
GSM 850							18.8	16.5		
P-GSM 900							19.8	17.5		
E-GSM 900							19.8	17.5		
DCS 1800	20.3	18								
PCS 1900	20.3	18								

Note 1: Applicable for dual-mode GSMUMTS.

Note 2: The test requirements for E-GSM 900 and P-GSM 900 are specified from GSM 900 minimum requirements in table 5.3.1.

NOTE: If the above Test Requirement differs from the Minimum Requirement then the Test Tolerance applied for this test is non-zero. The Test Tolerance for this test is defined and the explanation of how the Minimum Requirement has been relaxed by the Test Tolerance is given in Annex D.

5.4 Total Radiated Power (TRP) for TDD UE

5.4.1 Definition and applicability

The Total Radiated Power (TRP) is a measure of how much power the DUT actually radiates. The TRP is defined as the integral of the power transmitted in different directions over the entire radiation sphere:

$$TRP = \frac{1}{4\pi} \int (EIRP_{\theta}(\Omega; f) + EIRP_{\varphi}(\Omega; f)) d\Omega$$

Where Ω is the solid angle describing the direction, f is frequency. θ and φ are the orthogonal polarizations.

$EIRP_{\theta}$ and $EIRP_{\varphi}$ are the actually transmitted power-levels in corresponding polarizations.

Thus

$$TRP \approx \frac{\pi}{2NM} \sum_{n=0}^{N-1} \sum_{m=0}^{M-1} [EIRP_{\theta}(\theta_n, \varphi_m; f) + EIRP_{\varphi}(\theta_n, \varphi_m; f)] \sin(\theta_n)$$

In these formulas N and M are the number of sampling intervals for theta and phi. θ_n and φ_m are the measurement angles. The sampling intervals are discussed further in Section 5.1.2.

The TRP can also be calculated from Rayleigh faded samples of the total power transmitted from the UE/MS. The measurement of transmitter performance in an isotropic Rayleigh fading environment is based on sampling the radiated

power of the UE/MS for a discrete number of field combinations in the chamber. The average value of these statistically distributed samples is proportional to the TRP and by calibrating the average power transfer function, an absolute value of the TRP can be obtained. Thus

$$TRP \approx \frac{\sum_{n=1}^N \left(\frac{P_n}{C_n (1 - R_n)} \right)}{\sum_{n=1}^N P_{ref,n}}$$

where $P_{ref,n}$ is the reference power transfer function for fixed measurement antenna n , R_n is the reflection coefficient for fixed measurement antenna n and C_n is the path loss in the cables connecting the measurement receiver to fixed measurement antenna n . These parameters are calculated from the calibration measurement and are further discussed in Annex B.2. P_n is the average power measured by fixed measurement antenna n and can be calculated using the following expression:

$$P_n = \frac{\sum_{m=1}^M |S_{21,n,m}|^2}{M}$$

where $S_{21,n,m}$ is sample number m of the complex transfer function measured with fixed measurement antenna n and M is the total number of samples measured for each fixed measurement antenna.

The requirements and this test apply to all types of UTRA for the TDD UE for Release 8 and later releases.

5.4.2 Minimum Requirements

The average TRP of low, mid and high channel in beside head position shall be higher than minimum performance requirements for roaming bands shown in Table 5.4.1. The averaging shall be done in linear scale for the TRP results of both right and left side of the phantom head.

$$TRP_{average} = 10 \log \left[\frac{10^{P_{left_low}/10} + 10^{P_{left_mid}/10} + 10^{P_{left_high}/10} + 10^{P_{right_low}/10} + 10^{P_{right_mid}/10} + 10^{P_{right_high}/10}}{6} \right]$$

In addition the minimum TRP of each measured channel in beside head position shall be higher than minimum performance requirements shown in the columns "Min".

$$TRP_{min} = \min [P_{left_low}, P_{left_mid}, P_{left_high}, P_{right_low}, P_{right_mid}, P_{right_high}]$$

Table 5.4.1: TRP minimum performance requirement for UTRA LCR TDD roaming bands in the speech position and the primary mechanical mode

Operating band	Power Class 1		Power Class 2		Power Class 3		Power Class 4	
	Power (dBm)		Power (dBm)		Power (dBm)		Power (dBm)	
	Average	Min	Average	Min	Average	Min	Average	Min
a	-	-	+15	+13	-	-	-	-
b	-	-	TBD	TBD	-	-	-	-
c	-	-	TBD	TBD	-	-	-	-
d	-	-	TBD	TBD	-	-	-	-
e	-	-	+15	+13	-	-	-	-
f	-	-	+15	+13	-	-	-	-
Note:	Applicable for dual-mode GSM/UTRA LCR TDD.							

The normative reference for this clause is TS 25.144 section 6.1.1.3.

5.4.3 Test purpose

The purpose of this test is to verify that $TRP_{average}$ and TRP_{min} of the UE are not below specified values. A lower $TRP_{average}$ and TRP_{min} decrease the coverage area.

5.4.4 Method of test

5.4.4.1 Initial conditions

The output power is a measure of the maximum power the UE can transmit in a bandwidth of at least $(1 + \alpha)$ times the chip rate of the radio access mode, for more information see 3GPP TS 34.122 chapter 5.2. The period of measurement shall be at least one timeslot. Also care should be taken that the noise floor of the measurement receiver is not disturbing the power measurement. Normally, the receiving device should be set accordingly so that the receiving signal will be at least 30dB higher than the system noise floor.

Test environment: normal; see 3GPP TS34.122-1 [13] clause G.2.1.

Frequencies to be tested: low range, mid range, high range; see TS34.122-1 [13] clause G.2.4.

- 1) Set the SS downlink physical channels parameters. Set the DPCH power such that there will not be transmission gaps due to too low signal strength throughout the measurement.
- 2) Power on the UE.
- 3) A call is set up according to the Generic call setup procedure. The power control algorithm shall be set to Power Control Algorithm 2.
- 4) Enter the UE into loopback test mode and start the loopback test.
- 5) The measurement receiver shall be set to: zero span, video trigger and RMS detector. The RBW shall be at least $(1 + \alpha)$ times the chip rate of the radio access mode and the VBW at least 3 times bigger than the RBW. For 1.28Mcps TDD UE, the RBW shall be set to 3MHz, and VBW shall be set to 10MHz.

See TS 34.108 [10] and TS 34.109 [11] for details regarding generic call setup procedure and loopback test.

5.4.4.2 Procedure

- 1) Send continuously Up power control commands to the UE.
- 2) As the UE reaches maximum power, start sending PN15 data pattern.
- 3) Position the UE against the SAM phantom.
- 4) Measure the $EIRP_{\theta}$ and $EIRP_{\phi}$ with a sample step of 15° in theta (θ) and phi (ϕ) directions using a test system having characteristics as described in Annex A.
- 5) Calculate TRP using equations from chapter 5.4.1.

NOTE 1: The measurement procedure is based on the measurement of the spherical radiation pattern of the DUT. The power radiated by the DUT is sampled in far field in a group of points located on a spherical surface enclosing the DUT. The EIRP samples are taken using a constant sample step of 15° both in theta (θ) and phi (ϕ) directions. In some cases a different sampling grid may be used to speed up the measurements (See Section 5.1.2). All the EIRP samples are taken with two orthogonal polarizations, θ - and ϕ - polarizations.

NOTE 2: The noise floor of the measurement receiver shall not disturb the power measurement.

NOTE 3: Non Standard settings: To speed up sensitivity measurements, power measurements may be done with non standard modulation. However to obtain TRP result the measured EIRP figures shall be normalized by

$$\overline{\Delta EIRP} = \frac{1}{n} \sum_{i=1}^n (EIRP_{std_i} - EIRP_{nstd_i})$$

where $EIRP_{std_i}$ is power measurement done with standard setting. $EIRP_{nstd_i}$ is power measurement done with non standard modulation. n is amount of reference measurement points.

To ensure accuracy of TRP, the amount of reference points measured should be at least 4. It is recommended to spread the reference measurements equally during the measurement time.

5.4.4.3 Procedure, reverberation chamber method

- 1) Send continuously Up power control commands to the UE.
- 2) As the UE reaches maximum power, start sending PN15 data pattern.
- 3) Position the UE against the SAM phantom
- 4) Measure a sufficient number of independent samples (see section 5.1.3) of $S_{21,n,m}$ using a test system having the characteristics described in Annex A.
- 5) Calculate TRP using equations from section 5.4.1.

NOTE 1: The measurement procedure is based on the measurement of the total power radiated from the UE/MS to a full 3 dimensional isotropic environment with uniform elevation and azimuth field distribution. The power transmitted by the DUT is undergoing Rayleigh fading and is sampled by the fixed measurement antennas. Moreover, it is important that the samples collected are independent, in order to get sufficient accuracy of the estimated TRP value.

NOTE 2: The noise floor of the measurement receiver shall not disturb the power measurement.

5.4.5 Test requirements

The average TRP of low, mid and high channel in beside head position shall be higher than test performance requirements for roaming bands shown in Table 5.4.2. The averaging shall be done in linear scale for the TRP results of both right and left side of the phantom head.

$$TRP_{average} = 10 \log \left[\frac{10^{P_{left_low}/10} + 10^{P_{left_mid}/10} + 10^{P_{left_high}/10} + 10^{P_{right_low}/10} + 10^{P_{right_mid}/10} + 10^{P_{right_high}/10}}{6} \right]$$

In addition the minimum TRP of each measured channel in beside head position shall be higher than minimum performance requirements shown in the columns "Min".

$$TRP_{min} = \min [P_{left_low}, P_{left_mid}, P_{left_high}, P_{right_low}, P_{right_mid}, P_{right_high}]$$

Table 5.4.2: TRP test performance requirement for UTRA LCR TDD roaming bands in the speech position and the primary mechanical mode

Operating band	Power Class 1		Power Class 2		Power Class 3		Power Class 4	
	Power (dBm)		Power (dBm)		Power (dBm)		Power (dBm)	
	Average	Min	Average	Min	Average	Min	Average	Min
a	-	-	+14.3	+12	-	-	-	-
b	-	-	TBD	TBD	-	-	-	-
c	-	-	TBD	TBD	-	-	-	-
d	-	-	TBD	TBD	-	-	-	-
e	-	-	+14.3	+12	-	-	-	-
f	-	-	+14.3	+12	-	-	-	-

Note: Applicable for dual-mode GSM/UTRA LCR TDD.

NOTE: If the above Test Requirement differs from the Minimum Requirement then the Test Tolerance applied for this test is non-zero. The Test Tolerance for this test is defined and the explanation of how the Minimum Requirement has been relaxed by the Test Tolerance is given in Annex D.

5.5 Total Radiated Power (TRP) for FDD UE using LME

Editor's note: This test case is incomplete. The following aspects are either missing or not yet determined:

- *The TRP Minimum Performance Requirement for this test are undefined*
- *The Test Requirements and related Test Tolerances applicable for this test are undefined*

5.5.1 Definition and applicability

The Total Radiated Power (TRP) is a measure of how much power the DUT actually radiates. The TRP is defined as the integral of the power transmitted in different directions over the entire radiation sphere:

$$TRP = \frac{1}{4\pi} \oint (EIRP_{\theta}(\Omega; f) + EIRP_{\varphi}(\Omega; f)) d\Omega$$

Where Ω is the solid angle describing the direction, f is frequency. θ and φ are the orthogonal polarizations.

$EIRP_{\theta}$ and $EIRP_{\varphi}$ are the actually transmitted power-levels in corresponding polarizations.

Thus

$$TRP \approx \frac{\pi}{2NM} \sum_{n=0}^{N-1} \sum_{m=0}^{M-1} [EIRP_{\theta}(\theta_n, \varphi_m; f) + EIRP_{\varphi}(\theta_n, \varphi_m; f)] \sin(\theta_n)$$

In these formulas N and M are the number of sampling intervals for theta and phi. θ_n and φ_m are the measurement angles. The sampling intervals are discussed further in Section 5.1.2.

The TRP can also be calculated from Rayleigh faded samples of the total power transmitted from the LME. The measurement of transmitter performance in an isotropic Rayleigh fading environment is based on sampling the radiated power of the LME for a discrete number of field combinations in the chamber. The average value of these statistically distributed samples is proportional to the TRP and by calibrating the average power transfer function, an absolute value of the TRP can be obtained. Thus

$$TRP \approx \frac{\sum_{n=1}^N \left(\frac{P_n}{C_n(1-R_n)} \right)}{\sum_{n=1}^N P_{ref,n}}$$

where $P_{ref,n}$ is the reference power transfer function for fixed measurement antenna n, R_n is the reflection coefficient for fixed measurement antenna n and C_n is the path loss in the cables connecting the measurement receiver to fixed measurement antenna n. These parameters are calculated from the calibration measurement and are further discussed in Annex B.2. P_n is the average power measured by fixed measurement antenna n and can be calculated using the following expression:

$$P_n = \frac{\sum_{m=1}^M |S_{21,n,m}|^2}{M}$$

where $S_{21,n,m}$ is sample number m of the complex transfer function measured with fixed measurement antenna n and M is the total number of samples measured for each fixed measurement antenna.

The requirements and this test apply to all types of UTRA for the FDD UE for Release 11 and later releases that support LME.

NOTE: This test case can be optionally executed for Release 7 and onward UE's supporting LME feature.

5.5.2 Minimum Requirements

The average TRP of low, mid and high channel shall be higher than minimum performance requirements for roaming bands shown in Table 5.5.1. The averaging shall be done in linear scale for the TRP results.

$$TRP_{average} = 10 \log \left[\frac{10^{P_{low}/10} + 10^{P_{mid}/10} + 10^{P_{high}/10}}{3} \right]$$

In addition the minimum TRP of each measured channel shall be higher than minimum performance requirements shown in the columns "Min".

$$TRP_{min} = 10 \log \left[\min \left(10^{P_{low}/10}, 10^{P_{mid}/10}, 10^{P_{high}/10} \right) \right]$$

Table 5.5.1: TRP minimum performance requirement for FDD LME devices in the data transfers position

Operating band	Power Class 1	Power Class 2	Power Class 3		Power Class 3bis		Power Class 4	
	Power (dBm)	Power (dBm)	Power (dBm)		Power (dBm)		Power (dBm)	
			Average	Min	Average	Min	Average	Min
I	-	-	TBD	TBD	TBD	TBD	TBD	TBD
II	-	-	TBD	TBD	TBD	TBD	TBD	TBD
III	-	-	TBD	TBD	TBD	TBD	TBD	TBD
IV	-	-	TBD	TBD	TBD	TBD	TBD	TBD
V	-	-	TBD	TBD	TBD	TBD	TBD	TBD
VI	-	-	TBD	TBD	TBD	TBD	TBD	TBD
VII	-	-	TBD	TBD	TBD	TBD	TBD	TBD
VIII	-	-	TBD	TBD	TBD	TBD	TBD	TBD
IX	-	-	TBD	TBD	TBD	TBD	TBD	TBD
XIX	-	-	TBD	TBD	TBD	TBD	TBD	TBD

NOTE 1: Applicable for dual-mode GSM/UMTS.
NOTE 2: Applicable for USB plug-in devices.

The normative reference for this clause is TS25.144 [12] section 6.2.1.1.

5.5.3 Test purpose

The purpose of this test is to verify that $TRP_{average}$ and TRP_{min} of the UE is not below specified values. A lower $TRP_{average}$ and TRP_{min} decrease the coverage area.

5.5.4 Method of test

5.5.4.1 Initial conditions

The output power is a measure of the maximum power the UE can transmit in a bandwidth of at least $(1 + \alpha)$ times the chip rate of the radio access mode, for more information see TS 34.121-1 [3] clause 5.2. The period of measurement shall be at least one timeslot. Also care should be taken that the noise floor of the measurement receiver is not disturbing the power measurement.

Test environment: normal; see TS 34.121-1 [3] clause G.2.1.

Frequencies to be tested: low range, mid range, high range; see TS 34.121-1 [3] clause G.2.4.

- 1) Set the SS downlink physical channels according to settings in Table 5.5.2. Set the DPCH power such that there will not be transmission gaps due to too low signal strength throughout the measurement.
- 2) Connect the plug-in UE to a laptop ground plane phantom. Power on the plug-in UE. The real functional laptop supplies power to the plug-in UE.
- 3) A call is set up according to the Generic call setup procedure. The power control algorithm shall be set to Power Control Algorithm 2. Compressed mode shall be set to OFF.
- 4) Enter the UE into loopback test mode 2 and start the loopback test.

See TS 34.108 [10] and TS 34.109 [11] for details regarding generic call setup procedure and loopback test.

Table 5.5.2: Downlink Physical Channels transmitted during a connection

Physical Channel	Power
CPICH	CPICH_Ec / DPCH_Ec = 7 dB
P-CCPCH	P-CCPCH_Ec / DPCH_Ec = 5 dB
SCH	SCH_Ec / DPCH_Ec = 5 dB
PICH	PICH_Ec / DPCH_Ec = 2 dB
DPCH	Test dependent power

5.5.4.2 Procedure

- 1) Send continuously Up power control commands to the plug-in UE.
- 2) As the plug-in UE reaches maximum power, start sending PN15 data pattern.
- 3) Position the plug-in UE into the USB connector in accordance with the manufacturer recommended primary mechanical mode. In the absence of such a recommendation position the plug-in UE so that it is horizontally plugged into the horizontal USB connector.
- 4) Measure the $EIRP_{\theta}$ and $EIRP_{\phi}$ with a sample step of 15° in theta (θ) and phi (ϕ) directions using a test system having characteristics as described in Annex A.
- 5) Calculate TRP using equations from clause 5.5.1

NOTE 1: The measurement procedure is based on the measurement of the spherical radiation pattern of the DUT. The power radiated by the DUT is sampled in far field in a group of points located on a spherical surface enclosing the DUT. The EIRP samples are taken using a constant sample step of 15° both in theta (θ) and phi (ϕ) directions. In some cases a different sampling grid may be used to speed up the measurements (See Section 5.1.2). All the EIRP samples are taken with two orthogonal polarizations, θ - and ϕ - polarisations.

NOTE 2: The noise floor of the measurement receiver shall not disturb the power measurement.

NOTE 3: Non Standard settings: To speed up sensitivity measurements, power measurements may be done with non standard modulation. However to obtain TRP result the measured EIRP figures shall be normalized by

$$\Delta \overline{EIRP} = \frac{1}{n} \sum_{i=1}^n (EIRP_{std_i} - EIRP_{nstd_i})$$

where $EIRP_{std_i}$ is power measurement done with standard setting. $EIRP_{nstd_i}$ is power measurement done with non standard modulation. n is amount of reference measurement points.

To ensure accuracy of TRP, the amount of reference points measured should be at least 4. It is recommended to spread the reference measurements equally during the measurement time.

5.5.4.3 Procedure, reverberation chamber method

- 1) Send continuously Up power control commands to the plug-in UE.
- 2) As the plug-in UE reaches maximum power, start sending PN15 data pattern.
- 3) Position the plug-in UE into the USB connector in accordance with the manufacturer recommended primary mechanical mode. In the absence of such a recommendation position the plug-in UE so that it is horizontally plugged into the horizontal USB connector.
- 4) Measure a sufficient number of independent samples (see section 5.1.3) of $S_{21,n,m}$ using a test system having characteristics as described in Annex A.
- 5) Calculate TRP using equations from clause 5.5.1.

NOTE 1: The measurement procedure is based on the measurement of the total power radiated from the UE/MS to a full 3 dimensional isotropic environment with uniform elevation and azimuth field distribution. The power transmitted by the DUT is undergoing Rayleigh fading and is sampled by the fixed measurement antennas. Moreover, it is important that the samples collected are independent, in order to get sufficient accuracy of the estimated TRP value.

NOTE 2: The noise floor of the measurement receiver shall not disturb the power measurement.

5.5.5 Test requirements

The average TRP of low, mid and high channel shall be higher than test performance requirements for roaming bands shown in Table 5.5.3. The averaging shall be done in linear scale for the TRP.

$$TRP_{average} = 10 \log \left[\frac{10^{P_{low}/10} + 10^{P_{mid}/10} + 10^{P_{high}/10}}{3} \right]$$

In addition the minimum TRP of each measured channel shall be higher than minimum performance requirements shown in the columns "Min".

$$TRP_{min} = 10 \log \left[\min \left(10^{P_{low}/10}, 10^{P_{mid}/10}, 10^{P_{high}/10} \right) \right]$$

Table 5.5.3: TRP test requirement for FDD LME devices in the data transfers position

Operating band	Power Class 1	Power Class 2	Power Class 3		Power Class 3bis		Power Class 4	
	Power (dBm)	Power (dBm)	Power (dBm)		Power (dBm)		Power (dBm)	
			Average	Min	Average	Min	Average	Min
I	-	-	TBD +TT	TBD +TT	TBD +TT	TBD +TT	TBD +TT	TBD +TT
II	-	-	TBD +TT	TBD +TT	TBD +TT	TBD +TT	TBD +TT	TBD +TT
III	-	-	TBD +TT	TBD +TT	TBD +TT	TBD +TT	TBD +TT	TBD +TT
IV	-	-	TBD +TT	TBD +TT	TBD +TT	TBD +TT	TBD +TT	TBD +TT
V	-	-	TBD +TT	TBD +TT	TBD +TT	TBD +TT	TBD +TT	TBD +TT
VI	-	-	TBD +TT	TBD +TT	TBD +TT	TBD +TT	TBD +TT	TBD +TT
VII	-	-	TBD +TT	TBD +TT	TBD +TT	TBD +TT	TBD +TT	TBD +TT
VIII	-	-	TBD +TT	TBD +TT	TBD +TT	TBD +TT	TBD +TT	TBD +TT
IX	-	-	TBD +TT	TBD +TT	TBD +TT	TBD +TT	TBD +TT	TBD +TT
XIX	-	-	TBD +TT	TBD +TT	TBD +TT	TBD +TT	TBD +TT	TBD +TT

NOTE 1: Applicable for dual-mode GSM/UMTS.
NOTE 2: Applicable for USB plug-in devices.

NOTE: If the above Test Requirement differs from the Minimum Requirement then the Test Tolerance applied for this test is non-zero. The Test Tolerance for this test is defined and the explanation of how the Minimum Requirement has been relaxed by the Test Tolerance is given in Annex D.

5.6 Total Radiated Power (TRP) for GSM MS using LME

Editor's note: This test case is not completed

Minimum Requirements are missing

Test requirements and related TT are missing

5.6.1 Definition and applicability

The Total Radiated Power (TRP) is a measure of how much power the DUT actually radiates. The TRP is defined as the integral of the power transmitted in different directions over the entire radiation sphere:

$$TRP = \frac{1}{4\pi} \oint (EIRP_{\theta}(\Omega; f) + EIRP_{\varphi}(\Omega; f)) d\Omega$$

Where Ω is the solid angle describing the direction, f is frequency. θ and φ are the orthogonal polarizations.

$EIRP_{\theta}$ and $EIRP_{\varphi}$ are the actually transmitted power-levels in corresponding polarizations.

Thus

$$TRP \approx \frac{\pi}{2NM} \sum_{n=0}^{N-1} \sum_{m=0}^{M-1} [EIRP_{\theta}(\theta_n, \varphi_m; f) + EIRP_{\varphi}(\theta_n, \varphi_m; f)] \sin(\theta_n)$$

In these formulas N and M are the number of sampling intervals for theta and phi. θ_n and φ_m are the measurement angles. The sampling intervals are discussed further in Section 5.1.2.

The TRP can also be calculated from Rayleigh faded samples of the total power transmitted from the LME. The measurement of transmitter performance in an isotropic Rayleigh fading environment is based on sampling the radiated power of the LME for a discrete number of field combinations in the chamber. The average value of these statistically distributed samples is proportional to the TRP and by calibrating the average power transfer function, an absolute value of the TRP can be obtained. Thus

$$TRP \approx \frac{\sum_{n=1}^N \left(\frac{P_n}{C_n(1-R_n)} \right)}{\sum_{n=1}^N P_{ref,n}}$$

where $P_{ref,n}$ is the reference power transfer function for fixed measurement antenna n, R_n is the reflection coefficient for fixed measurement antenna n and C_n is the path loss in the cables connecting the measurement receiver to fixed measurement antenna n. These parameters are calculated from the calibration measurement and are further discussed in Annex B.2. P_n is the average power measured by fixed measurement antenna n and can be calculated using the following expression:

$$P_n = \frac{\sum_{m=1}^M |S_{21,n,m}|^2}{M}$$

where $S_{21,n,m}$ is sample number m of the complex transfer function measured with fixed measurement antenna n and M is the total number of samples measured for each fixed measurement antenna.

The requirements and this test apply to all types of LME that support GSM for Release 11 and later releases.

NOTE: This test case can be optionally executed for Release 7 and onward MS's supporting LME feature.

5.6.2 Minimum Requirements

The average TRP of low, mid and high channel of the LME in the data transfers position shall be higher than minimum performance requirements for roaming bands shown in Table 5.6.1. The averaging shall be done in linear scale for the TRP results.

$$TRP_{average} = 10 \log \left[\frac{10^{P_{low}/10} + 10^{P_{mid}/10} + 10^{P_{high}/10}}{3} \right]$$

In addition the minimum TRP of each measured channel in the data transfers position shall be higher than minimum performance requirements shown in the columns "Min".

$$TRP_{min} = \min [P_{low}, P_{mid}, P_{high}]$$

Table 5.6.1: TRP minimum performance requirement for GSM LME devices in the data transfers position

Operating band	Power Class 1		Power Class 2		Power Class 3		Power Class 4		Power Class 5	
	Power (dBm)		Power (dBm)		Power (dBm)		Power (dBm)		Power (dBm)	
	Average	Min	Average	Min	Average	Min	Average	Min	Average	Min
GSM 850	-	-	-	-	-	-	TBD	TBD	-	-
GSM 900	-	-	-	-	-	-	TBD	TBD	-	-
DCS 1800	TBD	TBD	-	-	-	-	-	-	-	-
PCS 1900	TBD	TBD	-	-	-	-	-	-	-	-

NOTE 1: Applicable for dual-mode GSM/UMTS.

NOTE 2: Applicable for USB plug-in devices.

The normative reference for this clause is TS25.144 section 6.2.1.2.

5.6.3 Test purpose

The purpose of this test is to verify that $TRP_{average}$ and TRP_{min} of the MS is not below specified values. A lower $TRP_{average}$ and TRP_{min} decrease the coverage area.

5.6.4 Method of test

5.6.4.1 Initial conditions

A call is set up by the SS according to the generic call set up procedure on a channel with ARFCN in the Mid ARFCN range, power control level set to Maxpower. MS TXPWR_MAX_CCH is set to the maximum value supported by the Power Class of the Mobile under test.

The SS sends Standard Test Signal C1; see TS51.010-1 [9] Annex A5.2.

The downlink power is set such that there will not be transmission gaps due to too low signal strength throughout the measurement

The LME shall be tested using the Laptop Ground Plane Phantom as described in Annex A.1.2.

Test environment: normal condition; see TS51.010-1 [9] Annex A1.2.2.

5.6.4.2 Procedure

- 1) Position the LME using the Laptop Ground Plane Phantom described in annex A.1.2 and according to DUT positioning described in clause 5.1.1.
- 2) Measure the $EIRP_{\theta}$ and $EIRP_{\phi}$ with a sample step of 15° in theta (θ) and phi (ϕ) directions using a test system having characteristics as described in Annex A.
- 3) Calculate TRP using equations from clause 5.6.1
- 4) Test steps 1 to 3 is repeated for ARFCN in the low and high range

NOTE 1: Measurement of normal burst transmitter output power. The SS takes power measurement samples evenly distributed over the duration of one burst with a sampling rate of at least $2/T$, where T is the bit duration. The samples are identified in time with respect to the modulation on the burst. The SS identifies the centre of the useful 147 transmitted bits, i.e. the transition from bit 13 to bit 14 of the midamble, as the timing reference.

NOTE 2: The measurement procedure is based on the measurement of the spherical radiation pattern of the DUT. The power radiated by the DUT is sampled in far field in a group of points located on a closed surface enclosing the DUT. The EIRP samples are taken using a constant sample step of 15° both in theta (θ) and phi (ϕ) directions. In some cases a different sampling grid can be used to speed up the measurements (See Section 5.1.2). All the EIRP samples are taken with two orthogonal polarizations, θ - and ϕ - polarisations.

NOTE 3: The noise floor of the measurement receiver shall not disturb the power measurement.

NOTE 4: Non Standard settings: To speed up sensitivity measurements, power measurements can be done with non standard modulation. However to obtain TRP result the measured EIRP figures shall be normalized by

$$\overline{\Delta EIRP} = \frac{1}{n} \sum_{i=1}^n (EIRPstd_i - EIRPnstd_i)$$

where $EIRPstd_i$ is power measurement done with standard setting. $EIRPnstd_i$ is power measurement done with non standard modulation. n is amount of reference measurement points.

To ensure accuracy of TRP, the amount of reference points measured should be at least 4. It is recommended to spread the reference measurements equally during the measurement time.

5.6.4.3 Procedure, reverberation chamber method

- 1) Position the LME using the Laptop Ground Plane Phantom described in Annex A.1.2 and according to DUT positioning described in chapter 5.1.1.
- 2) Measure a sufficient number of independent samples (see section 5.1.3) of $S_{21,n,m}$ using a test system having the characteristics described in Annex A.
- 3) Calculate TRP using equations from clause 5.6.1.
- 4) Test steps 1 to 3 is repeated for ARFCN in the low and high range

NOTE 1: Measurement of normal burst transmitter output power. The SS takes power measurement samples evenly distributed over the duration of one burst with a sampling rate of at least $2/T$, where T is the bit duration. The samples are identified in time with respect to the modulation on the burst. The SS identifies the centre of the useful 147 transmitted bits, i.e. the transition from bit 13 to bit 14 of the midamble, as the timing reference.

NOTE 2: The measurement procedure is based on the measurement of the total power radiated from the UE/MS to a full 3 dimensional isotropic environment with uniform elevation and azimuth field distribution. The power transmitted by the DUT is undergoing Rayleigh fading and is sampled by the fixed measurement antennas. Moreover, it is important that the samples collected are independent, in order to get sufficient accuracy of the estimated TRP value.

NOTE 3: The noise floor of the measurement receiver shall not disturb the power measurement.

5.6.5 Test requirements

The average TRP of low, mid and high channel in the data transfers position shall be higher than test performance requirements for roaming bands shown in Table 5.6.2. The averaging shall be done in linear scale for the TRP results.

$$TRP_{average} = 10 \log \left[\frac{10^{P_{low}/10} + 10^{P_{mid}/10} + 10^{P_{high}/10}}{3} \right]$$

In addition the minimum TRP of each measured channel in the data transfers position shall be higher than minimum performance requirements shown in the columns "Min".

$$TRP_{min} = \min [P_{low}, P_{mid}, P_{high}]$$

Table 5.6.2: TRP test requirement for GSM LME devices in the data transfers position

Operating band	Power Class 1		Power Class 2		Power Class 3		Power Class 4		Power Class 5	
	Power (dBm)		Power (dBm)		Power (dBm)		Power (dBm)		Power (dBm)	
	Average	Min	Average	Min	Average	Min	Average	Min	Average	Min
GSM 850	-	-	-	-	-	-	TBD	TBD	-	-
GSM 900	-	-	-	-	-	-	TBD	TBD	-	-
DCS 1800	TBD	TBD	-	-	-	-	-	-	-	-
PCS 1900	TBD	TBD	-	-	-	-	-	-	-	-
NOTE 1: Applicable for dual-mode GSM/UMTS.										
NOTE 2: Applicable for USB plug-in devices.										

NOTE: If the above Test Requirement differs from the Minimum Requirement then the Test Tolerance applied for this test is non-zero. The Test Tolerance for this test is defined and the explanation of how the Minimum Requirement has been relaxed by the Test Tolerance is given in Annex D.

5.7 Total Radiated Power (TRP) for TDD UE using LME

Editor's note: This test case is incomplete. The following aspects are either missing or not yet determined:

- The TRP Minimum Performance Requirement for this test are undefined
- The Test Requirements and related Test Tolerances applicable for this test are undefined

5.7.1 Definition and applicability

The Total Radiated Power (TRP) is a measure of how much power the DUT actually radiates. The TRP is defined as the integral of the power transmitted in different directions over the entire radiation sphere:

$$TRP = \frac{1}{4\pi} \oint (EIRP_{\theta}(\Omega; f) + EIRP_{\varphi}(\Omega; f)) d\Omega$$

Where Ω is the solid angle describing the direction, f is frequency. θ and φ are the orthogonal polarizations.

$EIRP_{\theta}$ and $EIRP_{\varphi}$ are the actually transmitted power-levels in corresponding polarizations.

Thus

$$TRP \approx \frac{\pi}{2NM} \sum_{n=0}^{N-1} \sum_{m=0}^{M-1} [EIRP_{\theta}(\theta_n, \varphi_m; f) + EIRP_{\varphi}(\theta_n, \varphi_m; f)] \sin(\theta_n)$$

In these formulas N and M are the number of sampling intervals for theta and phi. θ_n and φ_m are the measurement angles. The sampling intervals are discussed further in Section 5.1.2.

The TRP can also be calculated from Rayleigh faded samples of the total power transmitted from the LME. The measurement of transmitter performance in an isotropic Rayleigh fading environment is based on sampling the radiated power of the LME for a discrete number of field combinations in the chamber. The average value of these statistically distributed samples is proportional to the TRP and by calibrating the average power transfer function, an absolute value of the TRP can be obtained. Thus

$$TRP \approx \frac{\sum_{n=1}^N \left(\frac{P_n}{C_n (1 - R_n)} \right)}{\sum_{n=1}^N P_{ref,n}}$$

where $P_{ref,n}$ is the reference power transfer function for fixed measurement antenna n , R_n is the reflection coefficient for fixed measurement antenna n and C_n is the path loss in the cables connecting the measurement receiver to fixed measurement antenna n . These parameters are calculated from the calibration measurement and are further discussed in Annex B.2. P_n is the average power measured by fixed measurement antenna n and can be calculated using the following expression:

$$P_n = \frac{\sum_{m=1}^M |S_{21,n,m}|^2}{M}$$

where $S_{21,n,m}$ is sample number m of the complex transfer function measured with fixed measurement antenna n and M is the total number of samples measured for each fixed measurement antenna.

The requirements and this test apply to all types of UTRA for the TDD UE for Release 11 and later releases that support LME.

NOTE: This test case can be optionally executed for Release 8 and onward UE's supporting LME feature.

5.7.2 Minimum Requirements

The average TRP of low, mid and high channel shall be higher than minimum performance requirements for roaming bands shown in Table 5.7.1. The averaging shall be done in linear scale for the TRP results.

$$TRP_{average} = 10 \log \left[\frac{10^{P_{low}/10} + 10^{P_{mid}/10} + 10^{P_{high}/10}}{3} \right]$$

In addition the minimum TRP of each measured channel shall be higher than minimum performance requirements shown in the columns "Min".

$$TRP_{min} = 10 \log \left[\min \left(10^{P_{low}/10}, 10^{P_{mid}/10}, 10^{P_{high}/10} \right) \right]$$

Table 5.7.1: TRP minimum performance requirement for TDD LME devices in the data transfers position

Operating band	Power Class 1		Power Class 2		Power Class 3		Power Class 4	
	Power (dBm)		Power (dBm)		Power (dBm)		Power (dBm)	
	Average	Min	Average	Min	Average	Min	Average	Min
a	-	-	TBD	TBD	-	-	-	-
b	-	-	TBD	TBD	-	-	-	-
c	-	-	TBD	TBD	-	-	-	-
d	-	-	TBD	TBD	-	-	-	-
e	-	-	TBD	TBD	-	-	-	-
f	-	-	TBD	TBD	-	-	-	-

NOTE 1: Applicable for dual-mode GSM/UTRA/LCR TDD.
NOTE 2: Applicable for USB plug-in devices.

The normative reference for this clause is TS25.144 [12] section 6.2.1.3.

5.7.3 Test purpose

The purpose of this test is to verify that $TRP_{average}$ and TRP_{min} of the UE is not below specified values. A lower $TRP_{average}$ and TRP_{min} decrease the coverage area.

5.7.4 Method of test

5.7.4.1 Initial conditions

The output power is a measure of the maximum power the UE can transmit in a bandwidth of at least $(1 + \alpha)$ times the chip rate of the radio access mode, for more information see TS 34.122 [13] clause 5.2. The period of measurement shall be at least one timeslot. Also care should be taken that the noise floor of the measurement receiver is not disturbing the power measurement. Normally, the receiving device should be set accordingly so that the receiving signal will be at least 30 dB higher than the system noise floor.

Test environment: normal; see TS 34.122 [13] clause G.2.1.

Frequencies to be tested: low range, mid range, high range; see TS 34.122 [13] clause G.2.4.

- 1) Set the SS downlink physical channels according to settings in Table 5.7.2. Set the DPCH power such that there will not be transmission gaps due to too low signal strength throughout the measurement.
- 2) Connect the plug-in UE to a laptop ground plane phantom. Power on the plug-in UE. The real functional laptop supplies power to the plug-in UE.

- 3) A call is set up according to the Generic call setup procedure. The power control algorithm shall be set to Power Control Algorithm 2.
- 4) Enter the UE into loopback test mode and start the loopback test.
- 5) The measurement receiver shall be set to: zero span, video trigger and RMS detector. The RBW shall be at least $(1 + \alpha)$ times the chip rate of the radio access mode and the VBW at least 3 times bigger than the RBW. For 1.28Mcps TDD UE, the RBW shall be set to 3MHz, and VBW shall be set to 10MHz.

See TS 34.108 [10] and TS 34.109 [11] for details regarding generic call setup procedure and loopback test.

Table 5.7.2: Downlink Physical Channels transmitted during a connection

Physical Channel	Power
lor	-75 dBm
DwPCH	$DwPCH_Ec / lor = 0$ dB
PCCPCH	$\sum P_CCPCH_Ec / lor = -3$ dB
SCCPCH	$\sum S_CCPCH_Ec / lor = -6$ dB
PICH	$\sum PICH_Ec / lor = -6$ dB
FPACH	$FPACH_Ec / lor = -6$ dB
DL DPCH	$\sum DPCH_Ec / lor = 0$ dB

5.7.4.2 Procedure

- 1) Send continuously Up power control commands to the plug-in UE.
- 2) As the plug-in UE reaches maximum power, start sending PN15 to Position the plug-in UE into the USB connector in accordance with the manufacturer recommended primary mechanical mode. In the absence of such a recommendation position the plug-in UE so that it is horizontally plugged into the horizontal USB connector.ta pattern.
- 3)
- 4) Measure the $EIRP_{\theta}$ and $EIRP_{\phi}$ with a sample step of 15° in theta (θ) and phi (ϕ) directions using a test system having characteristics as described in Annex A.
- 5) Calculate TRP using equations from clause 5.7.1

NOTE 1: The measurement procedure is based on the measurement of the spherical radiation pattern of the DUT. The power radiated by the DUT is sampled in far field in a group of points located on a spherical surface enclosing the DUT. The EIRP samples are taken using a constant sample step of 15° both in theta (θ) and phi (ϕ) directions. In some cases a different sampling grid may be used to speed up the measurements (See Section 5.1.2). All the EIRP samples are taken with two orthogonal polarizations, θ - and ϕ - polarisations.

NOTE 2: The noise floor of the measurement receiver shall not disturb the power measurement.

NOTE 3: Non Standard settings: To speed up sensitivity measurements, power measurements may be done with non standard modulation. However to obtain TRP result the measured EIRP figures shall be normalized by

$$\overline{\Delta EIRP} = \frac{1}{n} \sum_{i=1}^n (EIRP_{std_i} - EIRP_{nstd_i})$$

where $EIRP_{std_i}$ is power measurement done with standard setting. $EIRP_{nstd_i}$ is power measurement done with non standard modulation. n is amount of reference measurement points.

To ensure accuracy of TRP, the amount of reference points measured should be at least 4. It is recommended to spread the reference measurements equally during the measurement time.

5.7.4.3 Procedure, reverberation chamber method

- 1) Send continuously Up power control commands to the plug-in UE.
- 2) As the plug-in UE reaches maximum power, start sending PN15 data pattern.
- 3) Position the plug-in UE into the USB connector in accordance with the manufacturer recommended primary mechanical mode. In the absence of such a recommendation position the plug-in UE so that it is horizontally plugged into the horizontal USB connector.
- 4) Measure a sufficient number of independent samples (see section 5.1.3) of $S_{21,n,m}$ using a test system having the characteristics described in Annex A.
- 5) Calculate TRP using equations from section 5.7.1.

NOTE 1: The measurement procedure is based on the measurement of the total power radiated from the UE/MS to a full 3 dimensional isotropic environment with uniform elevation and azimuth field distribution. The power transmitted by the DUT is undergoing Rayleigh fading and is sampled by the fixed measurement antennas. Moreover, it is important that the samples collected are independent, in order to get sufficient accuracy of the estimated TRP value.

NOTE 2: The noise floor of the measurement receiver shall not disturb the power measurement.

5.7.5 Test requirements

The average TRP of low, mid and high channel shall be higher than test performance requirements for roaming bands shown in Table 5.7.3. The averaging shall be done in linear scale for the TRP.

$$TRP_{average} = 10 \log \left[\frac{10^{P_{low}/10} + 10^{P_{mid}/10} + 10^{P_{high}/10}}{3} \right]$$

In addition the minimum TRP of each measured channel shall be higher than minimum performance requirements shown in the columns "Min".

$$TRP_{min} = 10 \log \left[\min \left(10^{P_{low}/10}, 10^{P_{mid}/10}, 10^{P_{high}/10} \right) \right]$$

Table 5.7.3: TRP test requirement for TDD LME devices in the data transfers position

Operating band	Power Class 1		Power Class 2		Power Class 3		Power Class 4	
	Power (dBm)		Power (dBm)		Power (dBm)		Power (dBm)	
	Average	Min	Average	Min	Average	Min	Average	Min
a	-	-	TBD + TT	TBD + TT	-	-	-	-
b	-	-	TBD + TT	TBD + TT	-	-	-	-
c	-	-	TBD + TT	TBD + TT	-	-	-	-
d	-	-	TBD + TT	TBD + TT	-	-	-	-
e	-	-	TBD + TT	TBD + TT	-	-	-	-
f	-	-	TBD + TT	TBD + TT	-	-	-	-

NOTE 1: Applicable for dual-mode GSM/UTRA LCR TDD.
NOTE 2: Applicable for USB plug-in devices.

NOTE: If the above Test Requirement differs from the Minimum Requirement then the Test Tolerance applied for this test is non-zero. The Test Tolerance for this test is defined and the explanation of how the Minimum Requirement has been relaxed by the Test Tolerance is given in Annex D.

5.8 Total Radiated Power (TRP) for FDD UE using LEE

Editor's note: This test case is not completed

- Minimum Requirements are missing
- Test requirements and related TT are missing

5.8.1 Definition and applicability

The Total Radiated Power (TRP) is a measure of how much power the DUT actually radiates. The TRP is defined as the integral of the power transmitted in different directions over the entire radiation sphere:

$$TRP = \frac{1}{4\pi} \oint (EIRP_{\theta}(\Omega; f) + EIRP_{\varphi}(\Omega; f)) d\Omega$$

Where Ω is the solid angle describing the direction, f is frequency. θ and φ are the orthogonal polarizations.

$EIRP_{\theta}$ and $EIRP_{\varphi}$ are the actually transmitted power-levels in corresponding polarizations.

Thus

$$TRP \approx \frac{\pi}{2NM} \sum_{n=0}^{N-1} \sum_{m=0}^{M-1} [EIRP_{\theta}(\theta_n, \varphi_m; f) + EIRP_{\varphi}(\theta_n, \varphi_m; f)] \sin(\theta_n)$$

In these formulas N and M are the number of sampling intervals for theta and phi. θ_n and φ_m are the measurement angles. The sampling intervals are discussed further in Section 5.1.2.

The TRP can also be calculated from Rayleigh faded samples of the total power transmitted from the LEE. The measurement of transmitter performance in an isotropic Rayleigh fading environment is based on sampling the radiated power of the LEE for a discrete number of field combinations in the chamber. The average value of these statistically distributed samples is proportional to the TRP and by calibrating the average power transfer function, an absolute value of the TRP can be obtained. Thus

$$TRP \approx \frac{\sum_{n=1}^N \left(\frac{P_n}{C_n (1 - R_n)} \right)}{\sum_{n=1}^N P_{ref,n}}$$

where $P_{ref,n}$ is the reference power transfer function for fixed measurement antenna n , R_n is the reflection coefficient for fixed measurement antenna n and C_n is the path loss in the cables connecting the measurement receiver to fixed measurement antenna n . These parameters are calculated from the calibration measurement and are further discussed in Annex B.2. P_n is the average power measured by fixed measurement antenna n and can be calculated using the following expression:

$$P_n = \frac{\sum_{m=1}^M |S_{21,n,m}|^2}{M}$$

where $S_{21,n,m}$ is sample number m of the complex transfer function measured with fixed measurement antenna n and M is the total number of samples measured for each fixed measurement antenna.

Note that all averaging must be performed using linear power values (e.g. measurements in Watts).

The requirements and this test apply to all types of UTRA for the FDD UE for Release 11 and later releases that support LEE.

NOTE: This test case can be optionally executed for Release 7 and onward UE's supporting LEE feature.

5.8.2 Minimum Requirements

The average TRP of low, mid and high channel of the LME in the data transfers position shall be higher than minimum performance requirements for roaming bands shown in Table 5.8.1. The averaging shall be done in linear scale for the TRP results.

$$TRP_{average} = 10 \log \left[\frac{10^{P_{low}/10} + 10^{P_{mid}/10} + 10^{P_{high}/10}}{3} \right]$$

In addition the minimum TRP of each measured channel in the data transfers position shall be higher than minimum performance requirements shown in the columns "Min".

$$TRP_{min} = \min [P_{low}, P_{mid}, P_{high}]$$

Table 5.8.1: TRP minimum performance requirement for LEE devices in the data transfers position

Operating band	Power Class 1	Power Class 2	Power Class 3		Power Class 3bis		Power Class 4	
	Power (dBm)	Power (dBm)	Power (dBm)		Power (dBm)		Power (dBm)	
			Average	Min	Average	Min	Average	Min
I	-	-	TBD	TBD	TBD	TBD	TBD	TBD
II	-	-	TBD	TBD	TBD	TBD	TBD	TBD
III	-	-	TBD	TBD	TBD	TBD	TBD	TBD
IV	-	-	TBD	TBD	TBD	TBD	TBD	TBD
V	-	-	TBD	TBD	TBD	TBD	TBD	TBD
VI	-	-	TBD	TBD	TBD	TBD	TBD	TBD
VII	-	-	TBD	TBD	TBD	TBD	TBD	TBD
VIII	-	-	TBD	TBD	TBD	TBD	TBD	TBD
IX	-	-	TBD	TBD	TBD	TBD	TBD	TBD
XIX	-	-	TBD	TBD	TBD	TBD	TBD	TBD

NOTE 1: Applicable for dual-mode GSM/UMTS.
NOTE 2: Applicable for notebook devices.

The normative reference for this clause is TS25.144 section 6.2.1.1.

5.8.3 Test purpose

The purpose of this test is to verify that $TRP_{average}$ and TRP_{min} of the UE is not below specified values. A lower $TRP_{average}$ and TRP_{min} decrease the coverage area.

5.8.4 Method of test

5.8.4.1 Initial conditions

The output power is a measure of the maximum power the UE can transmit in a bandwidth of at least $(1 + \alpha)$ times the chip rate of the radio access mode, for more information see 3GPP TS 34.121 chapter 5.2. The period of measurement shall be at least one timeslot. Also care should be taken that the noise floor of the measurement receiver is not disturbing the power measurement.

The LEE shall be tested according to DUT positioning described in chapter 5.1.1.

Test environment: normal; see TS34.121-1 [3] clause G.2.1.

Frequencies to be tested: low range, mid range, high range; see TS34.121-1 [3] clause G.2.4.

- 1) Set the SS downlink physical channels according to settings in Table 5.8.2. Set the DPCH power such that there will not be transmission gaps due to too low signal strength throughout the measurement.
- 2) Power on the UE.
- 3) A call is set up according to the Generic call setup procedure. The power control algorithm shall be set to Power Control Algorithm 2. Compressed mode shall be set to OFF.
- 4) Enter the UE into loopback test mode 2 and start the loopback test.

See TS 34.108 [10] and TS 34.109 [11] for details regarding generic call setup procedure and loopback test.

Table 5.8.2: Downlink Physical Channels transmitted during a connection

Physical Channel	Power
CPICH	CPICH_Ec / DPCH_Ec = 7 dB
P-CCPCH	P-CCPCH_Ec / DPCH_Ec = 5 dB
SCH	SCH_Ec / DPCH_Ec = 5 dB
PICH	PICH_Ec / DPCH_Ec = 2 dB
DPCH	Test dependent power

5.8.4.2 Procedure

- 1) Send continuously Up power control commands to the UE.
- 2) As the UE reaches maximum power, start sending PN15 data pattern.
- 3) Position and configure the LEE according to chapter 5.1.1
- 4) Measure the $EIRP_{\theta}$ and $EIRP_{\phi}$ with a sample step of 15° in theta (θ) and phi (ϕ) directions using a test system having characteristics as described in Annex A.
- 5) Calculate TRP using equations from chapter 5.8.1

NOTE 1: The measurement procedure is based on the measurement of the spherical radiation pattern of the DUT. The power radiated by the DUT is sampled in far field in a group of points located on a spherical surface enclosing the DUT. The EIRP samples are taken using a constant sample step of 15° both in theta (θ) and phi (ϕ) directions. In some cases a different sampling grid may be used to speed up the measurements (See Section 5.1.2). All the EIRP samples are taken with two orthogonal polarizations, θ - and ϕ - polarisations.

NOTE 2: The noise floor of the measurement receiver shall not disturb the power measurement.

NOTE 3: Non Standard settings: To speed up sensitivity measurements, power measurements may be done with non standard modulation. However to obtain TRP result the measured EIRP figures shall be normalized by

$$\overline{\Delta EIRP} = \frac{1}{n} \sum_{i=1}^n (EIRP_{std_i} - EIRP_{nstd_i})$$

where $EIRP_{std_i}$ is power measurement done with standard setting. $EIRP_{nstd_i}$ is power measurement done with non standard modulation. n is amount of reference measurement points.

To ensure accuracy of TRP, the amount of reference points measured should be at least 4. It is recommended to spread the reference measurements equally during the measurement time.

5.8.4.3 Procedure, reverberation chamber method

- 1) Send continuously Up power control commands to the UE.
- 2) As the UE reaches maximum power, start sending PN15 data pattern.

- 3) Position and configure the LEE according to chapter 5.1.1
- 4) Measure a sufficient number of independent samples (see section 5.1.3) of $S_{21,n,m}$ using a test system having characteristics as described in Annex A.
- 5) Calculate TRP using equations from section 5.8.1.

NOTE 1: The measurement procedure is based on the measurement of the total power radiated from the UE/MS to a full 3 dimensional isotropic environment with uniform elevation and azimuth field distribution. The power transmitted by the DUT is undergoing Rayleigh fading and is sampled by the fixed measurement antennas. Moreover, it is important that the samples collected are independent, in order to get sufficient accuracy of the estimated TRP value.

NOTE 2: The noise floor of the measurement receiver shall not disturb the power measurement.

5.8.5 Test requirements

The average TRP of low, mid and high channel in the data transfers position shall be higher than test performance requirements for roaming bands shown in Table 5.8.3. The averaging shall be done in linear scale for the TRP results.

$$TRP_{average} = 10 \log \left[\frac{10^{P_{low}/10} + 10^{P_{mid}/10} + 10^{P_{high}/10}}{3} \right]$$

In addition the minimum TRP of each measured channel in the data transfers position shall be higher than minimum performance requirements shown in the columns "Min".

$$TRP_{min} = \min [P_{low}, P_{mid}, P_{high}]$$

Table 5.8.3: TRP test requirement for LEE devices in the data transfers position

Operating band	Power Class 1	Power Class 2	Power Class 3		Power Class 3bis		Power Class 4	
	Power (dBm)	Power (dBm)	Power (dBm)		Power (dBm)		Power (dBm)	
			Average	Min	Average	Min	Average	Min
I	-	-	TBD	TBD	TBD	TBD	TBD	TBD
II	-	-	TBD	TBD	TBD	TBD	TBD	TBD
III	-	-	TBD	TBD	TBD	TBD	TBD	TBD
IV	-	-	TBD	TBD	TBD	TBD	TBD	TBD
V	-	-	TBD	TBD	TBD	TBD	TBD	TBD
VI	-	-	TBD	TBD	TBD	TBD	TBD	TBD
VII	-	-	TBD	TBD	TBD	TBD	TBD	TBD
VIII	-	-	TBD	TBD	TBD	TBD	TBD	TBD
IX	-	-	TBD	TBD	TBD	TBD	TBD	TBD
XIX	-	-	TBD	TBD	TBD	TBD	TBD	TBD

NOTE 1: Applicable for dual-mode GSM/UMTS.

NOTE 2: Applicable for notebook devices.

NOTE: If the above Test Requirement differs from the Minimum Requirement then the Test Tolerance applied for this test is non-zero. The Test Tolerance for this test is defined and the explanation of how the Minimum Requirement has been relaxed by the Test Tolerance is given in Annex D.

5.9 Total Radiated Power (TRP) for GSM MS using LEE

Editor's note: This test case is not completed

- Minimum Requirements are missing
- Test requirements and related TT are missing

5.9.1 Definition and applicability

The Total Radiated Power (TRP) is a measure of how much power the DUT actually radiates. The TRP is defined as the integral of the power transmitted in different directions over the entire radiation sphere:

$$TRP = \frac{1}{4\pi} \oint (EIRP_{\theta}(\Omega; f) + EIRP_{\varphi}(\Omega; f)) d\Omega$$

Where Ω is the solid angle describing the direction, f is frequency. θ and φ are the orthogonal polarizations.

$EIRP_{\theta}$ and $EIRP_{\varphi}$ are the actually transmitted power-levels in corresponding polarizations.

Thus

$$TRP \approx \frac{\pi}{2NM} \sum_{n=0}^{N-1} \sum_{m=0}^{M-1} [EIRP_{\theta}(\theta_n, \varphi_m; f) + EIRP_{\varphi}(\theta_n, \varphi_m; f)] \sin(\theta_n)$$

In these formulas N and M are the number of sampling intervals for theta and phi. θ_n and φ_m are the measurement angles. The sampling intervals are discussed further in Section 5.1.2.

The TRP can also be calculated from Rayleigh faded samples of the total power transmitted from the LEE. The measurement of transmitter performance in an isotropic Rayleigh fading environment is based on sampling the radiated power of the LEE for a discrete number of field combinations in the chamber. The average value of these statistically distributed samples is proportional to the TRP and by calibrating the average power transfer function, an absolute value of the TRP can be obtained. Thus

$$TRP \approx \frac{\sum_{n=1}^N \left(\frac{P_n}{C_n (1 - R_n)} \right)}{\sum_{n=1}^N P_{ref,n}}$$

where $P_{ref,n}$ is the reference power transfer function for fixed measurement antenna n , R_n is the reflection coefficient for fixed measurement antenna n and C_n is the path loss in the cables connecting the measurement receiver to fixed measurement antenna n . These parameters are calculated from the calibration measurement and are further discussed in Annex B.2. P_n is the average power measured by fixed measurement antenna n and can be calculated using the following expression:

$$P_n = \frac{\sum_{m=1}^M |S_{21,n,m}|^2}{M}$$

where $S_{21,n,m}$ is sample number m of the complex transfer function measured with fixed measurement antenna n and M is the total number of samples measured for each fixed measurement antenna.

The requirements and this test apply to all types of LEE that support GSM for Release 11 and later releases.

NOTE: This test case can be optionally executed for Release 7 and onward MS's supporting LEE feature.

5.9.2 Minimum Requirements

The average TRP of low, mid and high channel of the LME in the data transfers position shall be higher than minimum performance requirements for roaming bands shown in Table 5.9.1. The averaging shall be done in linear scale for the TRP results.

$$TRP_{average} = 10 \log \left[\frac{10^{P_{low}/10} + 10^{P_{mid}/10} + 10^{P_{high}/10}}{3} \right]$$

In addition the minimum TRP of each measured channelling the data transfers position shall be higher than minimum performance requirements shown in the columns “Min”.

$$TRP_{min} = \min [P_{low}, P_{mid}, P_{high}]$$

Table 5.9.1: TRP minimum performance requirement for GSM LEE devices in the data transfer position

Operating band	Power Class 1		Power Class 2		Power Class 3		Power Class 4		Power Class 5	
	Power (dBm)		Power (dBm)		Power (dBm)		Power (dBm)		Power (dBm)	
	Average	Min	Average	Min	Average	Min	Average	Min	Average	Min
GSM 850	-	-	-	-	-	-	TBD	TBD	-	-
GSM 900	-	-	-	-	-	-	TBD	TBD	-	-
DCS 1800	TBD	TBD	-	-	-	-	-	-	-	-
PCS 1900	TBD	TBD	-	-	-	-	-	-	-	-
NOTE 1: Applicable for dual-mode GSM/UMTS.										
NOTE 2: Applicable for notebook devices.										

The normative reference for this clause is TS25.144 section 6.2.1.2.

5.9.3 Test purpose

The purpose of this test is to verify that $TRP_{average}$ and TRP_{min} of the MS is not below specified values. A lower $TRP_{average}$ and TRP_{min} decrease the coverage area.

5.9.4 Method of test

5.9.4.1 Initial conditions

A call is set up by the SS according to the generic call set up procedure on a channel with ARFCN in the Mid ARFCN range, power control level set to Max power. MS TXPWR_MAX_CCH is set to the maximum value supported by the Power Class of the Mobile under test.

The SS sends Standard Test Signal C1; see TS51.010-1 [9] Annex A5.2.

The downlink power is set such that there will not be transmission gaps due to too low signal strength throughout the measurement

The LEE shall be tested according to DUT positioning described in clause 5.1.1.

Test environment: normal condition; see TS51.010-1 [9] Annex A1.2.2.

5.9.4.2 Procedure

- 1) Position and configure the LEE according to clause 5.1.1
- 2) Measure the $EIRP_{\theta}$ and $EIRP_{\phi}$ with a sample step of 15° in theta (θ) and phi (ϕ) directions using a test system having characteristics as described in Annex A.
- 3) Calculate TRP using equations from clause 5.9.1
- 4) Test steps 1 to 3 is repeated for ARFCN in the low and high range

NOTE 1: Measurement of normal burst transmitter output power. The SS takes power measurement samples evenly distributed over the duration of one burst with a sampling rate of at least $2/T$, where T is the bit duration. The

samples are identified in time with respect to the modulation on the burst. The SS identifies the centre of the useful 147 transmitted bits, i.e. the transition from bit 13 to bit 14 of the midamble, as the timing reference.

NOTE 2: The measurement procedure is based on the measurement of the spherical radiation pattern of the DUT. The power radiated by the DUT is sampled in far field in a group of points located on a closed surface enclosing the DUT. The EIRP samples are taken using a constant sample step of 15° both in theta (θ) and phi (ϕ) directions. In some cases a different sampling grid can be used to speed up the measurements (See Section 5.1.2). All the EIRP samples are taken with two orthogonal polarizations, θ - and ϕ - polarisations.

NOTE 3: The noise floor of the measurement receiver shall not disturb the power measurement.

NOTE 4: Non Standard settings: To speed up sensitivity measurements, power measurements can be done with non standard modulation. However to obtain TRP result the measured EIRP figures shall be normalized by

$$\overline{\Delta EIRP} = \frac{1}{n} \sum_{i=1}^n (EIRP_{std_i} - EIRP_{nstd_i})$$

where $EIRP_{std_i}$ is power measurement done with standard setting. $EIRP_{nstd_i}$ is power measurement done with non standard modulation. n is amount of reference measurement points.

To ensure accuracy of TRP, the amount of reference points measured should be at least 4. It is recommended to spread the reference measurements equally during the measurement time.

5.9.4.3 Procedure, reverberation chamber method

- 1) Position and configure the LEE according to clause 5.1.1
- 2) Measure a sufficient number of independent samples (see section 5.1.3) of $S_{21,n,m}$ using a test system having the characteristics described in Annex A.
- 3) Calculate TRP using equations from section 5.9.1.
- 4) Test steps 1 to 3 is repeated for ARFCN in the low and high range

NOTE 1: Measurement of normal burst transmitter output power. The SS takes power measurement samples evenly distributed over the duration of one burst with a sampling rate of at least $2/T$, where T is the bit duration. The samples are identified in time with respect to the modulation on the burst. The SS identifies the centre of the useful 147 transmitted bits, i.e. the transition from bit 13 to bit 14 of the midamble, as the timing reference.

NOTE 2: The measurement procedure is based on the measurement of the total power radiated from the UE/MS to a full 3 dimensional isotropic environment with uniform elevation and azimuth field distribution. The power transmitted by the DUT is undergoing Rayleigh fading and is sampled by the fixed measurement antennas. Moreover, it is important that the samples collected are independent, in order to get sufficient accuracy of the estimated TRP value.

NOTE 3: The noise floor of the measurement receiver shall not disturb the power measurement.

5.9.5 Test requirements

The average TRP of low, mid and high channel in the data transfers position shall be higher than test performance requirements for roaming bands shown in Table 5.9.2. The averaging shall be done in linear scale for the TRP results.

$$TRP_{average} = 10 \log \left[\frac{10^{P_{low}/10} + 10^{P_{mid}/10} + 10^{P_{high}/10}}{3} \right]$$

In addition the minimum TRP of each measured channel in the data transfers position shall be higher than minimum performance requirements shown in the columns "Min".

$$TRP_{\min} = \min[P_{low}, P_{mid}, P_{high}]$$

Table 5.9.2: TRP test requirement for GSM LEE devices in the data transfer position

Operating band	Power Class 1		Power Class 2		Power Class 3		Power Class 4		Power Class 5	
	Power (dBm)		Power (dBm)		Power (dBm)		Power (dBm)		Power (dBm)	
	Average	Min	Average	Min	Average	Min	Average	Min	Average	Min
GSM 850	-	-	-	-	-	-	TBD	TBD	-	-
GSM 900	-	-	-	-	-	-	TBD	TBD	-	-
DCS 1800	TBD	TBD	-	-	-	-	-	-	-	-
PCS 1900	TBD	TBD	-	-	-	-	-	-	-	-

NOTE 1: Applicable for dual-mode GSM/UMTS.
NOTE 2: Applicable for notebook devices.

NOTE: If the above Test Requirement differs from the Minimum Requirement then the Test Tolerance applied for this test is non-zero. The Test Tolerance for this test is defined and the explanation of how the Minimum Requirement has been relaxed by the Test Tolerance is given in Annex D.

5.10 Total Radiated Power (TRP) for TDD UE using LEE

Editor's note: This test case is incomplete. The following aspects are either missing or not yet determined:

- The TRP Minimum Performance Requirement for this test are undefined
- The Test Requirements and related Test Tolerances applicable for this test are undefined

5.10.1 Definition and applicability

The Total Radiated Power (TRP) is a measure of how much power the DUT actually radiates. The TRP is defined as the integral of the power transmitted in different directions over the entire radiation sphere:

$$TRP = \frac{1}{4\pi} \oint (EIRP_{\theta}(\Omega; f) + EIRP_{\varphi}(\Omega; f)) d\Omega$$

Where Ω is the solid angle describing the direction, f is frequency. θ and φ are the orthogonal polarizations.

$EIRP_{\theta}$ and $EIRP_{\varphi}$ are the actually transmitted power-levels in corresponding polarizations.

Thus

$$TRP \approx \frac{\pi}{2NM} \sum_{n=0}^{N-1} \sum_{m=0}^{M-1} [EIRP_{\theta}(\theta_n, \varphi_m; f) + EIRP_{\varphi}(\theta_n, \varphi_m; f)] \sin(\theta_n)$$

In these formulas N and M are the number of sampling intervals for theta and phi. θ_n and φ_m are the measurement angles. The sampling intervals are discussed further in Section 5.1.2.

The TRP can also be calculated from Rayleigh faded samples of the total power transmitted from the LEE. The measurement of transmitter performance in an isotropic Rayleigh fading environment is based on sampling the radiated power of the LEE for a discrete number of field combinations in the chamber. The average value of these statistically distributed samples is proportional to the TRP and by calibrating the average power transfer function, an absolute value of the TRP can be obtained. Thus

$$TRP \approx \frac{\sum_{n=1}^N \left(\frac{P_n}{C_n (1 - R_n)} \right)}{\sum_{n=1}^N P_{ref,n}}$$

where $P_{ref,n}$ is the reference power transfer function for fixed measurement antenna n, R_n is the reflection coefficient for fixed measurement antenna n and C_n is the path loss in the cables connecting the measurement receiver to fixed measurement antenna n. These parameters are calculated from the calibration measurement and are further discussed in Annex B.2. P_n is the average power measured by fixed measurement antenna n and can be calculated using the following expression:

$$P_n = \frac{\sum_{m=1}^M |S_{21,n,m}|^2}{M}$$

where $S_{21,n,m}$ is sample number m of the complex transfer function measured with fixed measurement antenna n and M is the total number of samples measured for each fixed measurement antenna.

Note that all averaging must be performed using linear power values (e.g. measurements in Watts).

The requirements and this test apply to all types of UTRA for the TDD UE for Release 11 and later releases that support LEE.

Note: This test case can be optionally executed for Release 8 and onward UE's supporting LEE feature.

5.10.2 Minimum Requirements

The average TRP of low, mid and high channel shall be higher than minimum performance requirements for roaming bands shown in Table 5.10.1. The averaging shall be done in linear scale for the TRP results.

$$TRP_{average} = 10 \log \left[\frac{10^{P_{low}/10} + 10^{P_{mid}/10} + 10^{P_{high}/10}}{3} \right]$$

In addition the minimum TRP of each measured channel shall be higher than minimum performance requirements shown in the columns "Min".

$$TRP_{min} = 10 \log \left[\min \left(10^{P_{low}/10}, 10^{P_{mid}/10}, 10^{P_{high}/10} \right) \right]$$

Table 5.10.1: TRP minimum performance requirement for TDD LEE devices in the data transfers position

Operating band	Power Class 1		Power Class 2		Power Class 3		Power Class 4	
	Power (dBm)		Power (dBm)		Power (dBm)		Power (dBm)	
	Average	Min	Average	Min	Average	Min	Average	Min
a	-	-	TBD	TBD	-	-	-	-
b	-	-	TBD	TBD	-	-	-	-
c	-	-	TBD	TBD	-	-	-	-
d	-	-	TBD	TBD	-	-	-	-
e	-	-	TBD	TBD	-	-	-	-
f	-	-	TBD	TBD	-	-	-	-

NOTE 1: Applicable for dual-mode GSM/UTRA LCR TDD.
NOTE 2: Applicable for notebook devices.

The normative reference for this clause is TS25.144 [12] section 6.2.1.3.

5.10.3 Test purpose

The purpose of this test is to verify that $TRP_{average}$ and TRP_{min} of the UE is not below specified values. A lower $TRP_{average}$ and TRP_{min} decrease the coverage area.

5.10.4 Method of test

5.10.4.1 Initial conditions

The output power is a measure of the maximum power the UE can transmit in a bandwidth of at least $(1 + \alpha)$ times the chip rate of the radio access mode, for more information see TS 34.122 [13] clause 5.2. The period of measurement shall be at least one timeslot. Also care should be taken that the noise floor of the measurement receiver is not disturbing the power measurement. Normally, the receiving device should be set accordingly so that the receiving signal will be at least 30 dB higher than the system noise floor.

The LEE shall be tested according to DUT positioning described in clause 5.1.1.

Test environment: normal; see TS 34.122 [13] clause G.2.1.

Frequencies to be tested: low range, mid range, high range; see TS 34.122 [13] clause G.2.4.

- 1) Set the SS downlink physical channels according to settings in Table 5.10.2. Set the DPCH power such that there will not be transmission gaps due to too low signal strength throughout the measurement.
- 2) Power on the LEE UE
- 3) A call is set up according to the Generic call setup procedure. The power control algorithm shall be set to Power Control Algorithm 2.
- 4) Enter the UE into loopback test mode and start the loopback test.
- 5) The measurement receiver shall be set to: zero span, video trigger and RMS detector. The RBW shall be at least $(1 + \alpha)$ times the chip rate of the radio access mode and the VBW at least 3 times bigger than the RBW. For 1.28Mcps TDD UE, the RBW shall be set to 3MHz, and VBW shall be set to 10MHz.

See TS 34.108 [10] and TS 34.109 [11] for details regarding generic call setup procedure and loopback test.

Table 5.10.2: Downlink Physical Channels transmitted during a connection

Physical Channel	Power
lor	-75 dBm
DwPCH	$DwPCH_Ec / lor = 0$ dB
PCCPCH	$\sum P-CCPCH_Ec / lor = -3$ dB
SCCPCH	$\sum S-CCPCH_Ec / lor = -6$ dB
PICH	$\sum PICH_Ec / lor = -6$ dB
FPACH	$FPACH_Ec / lor = -6$ dB
DL DPCH	$\sum DPCH_Ec / lor = 0$ dB

5.10.4.2 Procedure

- 1) Send continuously Up power control commands to the LEE UE.
- 2) As the LEE UE reaches maximum power, start sending PN15 data pattern.
- 3) Position and configure the LEE according to clause 5.1.1
- 4) Measure the $EIRP_{\theta}$ and $EIRP_{\phi}$ with a sample step of 15° in theta (θ) and phi (ϕ) directions using a test system having characteristics as described in Annex A.
- 5) Calculate TRP using equations from clause 5.10.1

NOTE 1: The measurement procedure is based on the measurement of the spherical radiation pattern of the DUT. The power radiated by the DUT is sampled in far field in a group of points located on a spherical surface enclosing the DUT. The EIRP samples are taken using a constant sample step of 15° both in theta (θ) and phi (ϕ) directions. In some cases a different sampling grid may be used to speed up the measurements (See Section 5.1.2). All the EIRP samples are taken with two orthogonal polarizations, θ - and ϕ - polarisations.

NOTE 2: The noise floor of the measurement receiver shall not disturb the power measurement.

NOTE 3: Non Standard settings: To speed up sensitivity measurements, power measurements may be done with non standard modulation. However to obtain TRP result the measured EIRP figures shall be normalized by

$$\overline{\Delta EIRP} = \frac{1}{n} \sum_{i=1}^n (EIRP_{std_i} - EIRP_{nstd_i})$$

where $EIRP_{std_i}$ is power measurement done with standard setting. $EIRP_{nstd_i}$ is power measurement done with non standard modulation. n is amount of reference measurement points.

To ensure accuracy of TRP, the amount of reference points measured should be at least 4. It is recommended to spread the reference measurements equally during the measurement time.

5.10.4.3 Procedure, reverberation chamber method

- 1) Send continuously Up power control commands to the LEE UE.
- 2) As the UE reaches maximum power, start sending PN15 data pattern.
- 3) Position and configure the LEE according to clause 5.1.1
- 4) Measure a sufficient number of independent samples (see section 5.1.3) of $S_{21,n,m}$ using a test system having the characteristics described in Annex A.
- 5) Calculate TRP using equations from section 5.10.1.

NOTE 1: The measurement procedure is based on the measurement of the total power radiated from the UE/MS to a full 3 dimensional isotropic environment with uniform elevation and azimuth field distribution. The power transmitted by the DUT is undergoing Rayleigh fading and is sampled by the fixed measurement antennas. Moreover, it is important that the samples collected are independent, in order to get sufficient accuracy of the estimated TRP value.

NOTE 2: The noise floor of the measurement receiver shall not disturb the power measurement.

5.10.5 Test requirements

The average TRP of low, mid and high channel shall be higher than test performance requirements for roaming bands shown in Table 5.10.3. The averaging shall be done in linear scale for the TRP.

$$TRP_{average} = 10 \log \left[\frac{10^{P_{low}/10} + 10^{P_{mid}/10} + 10^{P_{high}/10}}{3} \right]$$

In addition the minimum TRP of each measured channel shall be higher than minimum performance requirements shown in the columns "Min".

$$TRP_{min} = 10 \log \left[\min \left(10^{P_{low}/10}, 10^{P_{mid}/10}, 10^{P_{high}/10} \right) \right]$$

Table 5.10.3: TRP test requirement for TDD LEE devices in the data transfers position

Operating band	Power Class 1		Power Class 2		Power Class 3		Power Class 4	
	Power (dBm)		Power (dBm)		Power (dBm)		Power (dBm)	
	Average	Min	Average	Min	Average	Min	Average	Min
a	-	-	TBD +TT	TBD +TT	-	-	-	-
b	-	-	TBD +TT	TBD +TT	-	-	-	-
c	-	-	TBD +TT	TBD +TT	-	-	-	-
d	-	-	TBD +TT	TBD +TT	-	-	-	-
e	-	-	TBD +TT	TBD +TT +TT	-	-	-	-
f	-	-	TBD +TT	TBD +TT	-	-	-	-

NOTE 1: Applicable for dual-mode GSM/UTRA LCR TDD.
NOTE 2: Applicable for notebook devices.

NOTE: If the above Test Requirement differs from the Minimum Requirement then the Test Tolerance applied for this test is non-zero. The Test Tolerance for this test is defined and the explanation of how the Minimum Requirement has been relaxed by the Test Tolerance is given in Annex D.

6 Receiver Performance

6.1 General

This section describes the specifics of the radiated sensitivity measurement procedure. There are two methods described. The main method is based on an anechoic chamber approach and the alternative method is based on a reverberation chamber approach.

The procedure for the measurement of the UE receiver performance is in principle equivalent to the transmitter performance measurement described in Annex A. The basic difference is that now the absolute sensitivity value at a predefined BER level is the parameter of interest in each measurement point. Note that the receiver and transmitter performances measurements may be done in parallel, at each position.

For DUTs with more than one antenna port, all the tests should be performed using both (all) antennas simultaneously.

6.1.1 DUT Positioning

The DUT positioning on head phantom means that the measurements are performed so that the DUT is placed against a SAM phantom. The characteristics of the SAM phantom are specified in Annex A.1.1. The DUT is attached to the SAM phantom in “cheek” position as defined in IEEE Std 1528. The DUT performance is measured on both left and right side of the head.

The DUT positioning on laptop ground plane phantom means that a laptop ground plane phantom is used for radiated performance measurements in case of plug-in DUT like USB dongles that is used away from the user’s head. The DUT is connected to the USB connector of the laptop ground plane phantom. The characteristics of the laptop ground plane phantom and the DUT positioning are specified in Annex A.1.2. The objective of the laptop ground plane phantom is to reproduce the effects of the ground plane for the antenna of the DUT while avoiding the variation of the measurements introduced by a real laptop. The DUT shall be plugged into the USB connector and positioned in accordance with the manufacturer recommended primary mechanical mode. In the absence of such a recommendation the DUT with either the rotary USB porter or non-rotary USB porter should be horizontally plugged into the horizontal USB connector.

The DUT positioning in free space configuration without head and hand phantoms as specified in Annex A.4 is used for radiated performance measurements in case of embedded module card that is used away from the user’s head.

6.1.2 Sampling grid

A 15°-sample grid in both azimuth and elevation can be considered sufficient for accurate measurements. Generally it can be said that since the radiating object has a limited size the gain pattern cannot change arbitrarily versus angle, and therefore only a limited number of samples are required to represent the gain pattern to a given accuracy consequently. A 30°-sample grid may be used taking also into account that there is a trade-off between the accuracy of the approximated TRS values and the total measurement time required to obtain a complete 3-D radiation pattern of the antenna.

Alternatively, different sampling patterns may be used, if they are able to ensure same or greater level of accuracy. The TRS can be calculated by interpolating the values to points on the regular grid. If an alternative sampling pattern is used number of measurement points should be greater than in the regular sampling grid.

6.1.3 Number of independent samples (for reverberation chamber procedure)

When measuring the TRS in an isotropic Rayleigh fading environment, 100 independent samples can be considered sufficient for ensuring an expanded accuracy better than 0.5 dB.

6.2 Total Radiated Sensitivity (TRS) for FDD UE

6.2.1 Definition and applicability

The Total Radiated Sensitivity is defined as:

$$TRS = \frac{4\pi}{\oint \left[\frac{1}{EIS_{\theta}(\Omega; f)} + \frac{1}{EIS_{\varphi}(\Omega; f)} \right] d\Omega}$$

Where the effective isotropic sensitivity (*EIS*) is defined as the power available at the antenna output such as the sensitivity threshold is achieved for each polarization. Ω is the solid angle describing the direction, f is frequency. θ and φ are the orthogonal polarizations.

$$TRS \approx \frac{2NM}{\pi \sum_{n=0}^{N-1} \sum_{m=0}^{M-1} \left[\frac{1}{EIS_{\theta}(\theta_n, \varphi_m; f)} + \frac{1}{EIS_{\varphi}(\theta_n, \varphi_m; f)} \right] \sin(\theta_n)}$$

In these formulas N and M are the number of sampling intervals for theta and phi. θ_n and φ_m are the measurement angles. The sampling intervals are discussed further in Section 6.1.2.

The TRS can also be calculated from measurements in a Rayleigh fading 3 dimensional isotropic environment with in average uniform elevation and azimuth distribution. The calculation of the TRS is in this case based on searching for the lowest power received by the UE/MS for a discrete number of field combinations in the chamber that gives a BER that is better than the specified target BER level. By calibrating the average power transfer function, an absolute value of the TRS can be obtained. The following expression can be used to find the TRS.

$$TRS \approx 2N \frac{\left(\sum_{n=1}^N (C_n (1 - R_n) P_{thres,n}) \right)^{-1}}{\sum_{n=1}^N P_{ref,n}}$$

where $P_{ref,n}$ is the reference power transfer function for fixed measurement antenna n, R_n is the reflection coefficient for fixed measurement antenna n and C_n is the path loss in the cables connecting the measurement receiver to fixed measurement antenna n. These parameters are calculated from the calibration measurement and are further discussed in Annex B.2. $P_{thres,n}$ is calculated by using the following equation:

$$P_{thres,n} = \frac{\sum_{m=1}^M \frac{1}{|S_{21,n,m}^{thres}|^2}}{M}$$

where $S_{21,n,m}^{thres}$ is the m:th value of the transfer function for fixed measurement antenna n, which gives the BER threshold. M is the total number of values of the BER threshold power measured for each fixed measurement antenna.

The requirements and this test apply to all types of UTRA for the FDD UE for Release 7 and later releases.

6.2.2 Minimum requirements

The average TRS of low, mid and high channel in beside head position for 1% BER with 12.2kbps DL reference channel as defined in Annex C.3 of TS25.101 [2] shall be lower than minimum performance requirements for roaming bands shown in Table 6.2.1. The averaging shall be done in linear scale for the TRS results of both right and left side of the phantom head.

$$TRS_{average} = 10 \log \left[6 / \left(\frac{1}{10^{P_{left_low}/10}} + \frac{1}{10^{P_{left_mid}/10}} + \frac{1}{10^{P_{left_high}/10}} + \frac{1}{10^{P_{right_low}/10}} + \frac{1}{10^{P_{right_mid}/10}} + \frac{1}{10^{P_{right_high}/10}} \right) \right]$$

In addition the maximum TRS of each measured channel in beside head position shall be better than minimum performance requirements for roaming bands shown in the columns "Max".

$$TRS_{max} = 10 \log \left[\max \left(10^{P_{left_low}/10}, 10^{P_{left_mid}/10}, 10^{P_{left_high}/10}, 10^{P_{right_low}/10}, 10^{P_{right_mid}/10}, 10^{P_{right_high}/10} \right) \right]$$

Table 6.2.1: TRS minimum requirements for FDD roaming bands in the speech position for the primary mechanical mode

Operating Band	Unit	<REF _{or} >	
		Average	Max
I	dBm/3.84 MHz	-101	-98
II	dBm/3.84 MHz	-99	-96
III	dBm/3.84 MHz	-98	-95
IV	dBm/3.84 MHz	-101	-98
V	dBm/3.84 MHz	-96	-93
VI	dBm/3.84 MHz	-96	-93
VII	dBm/3.84 MHz	-99	-96
VIII	dBm/3.84 MHz	-96	-93
IX	dBm/3.84 MHz	-100	-97
XIX	dBm/3.84 MHz	-96	-93
NOTE 1	For Power Class 3, 3bis and 4 this shall be achieved at the maximum output power.		
NOTE 2	For the UE which supports both Band III and Band IX operating frequencies, the reference level of TDB dBm TRS <REF _{or} > [average and min] shall apply for Band IX.		
NOTE 3:	Applicable for dual-mode GSM/UMTS.		

The normative reference for this clause is TS25.144 section 7.2.1.

6.2.3 Test Purpose

The purpose of this test is to ensure that $TRS_{average}$ and TRS_{max} of the UE is above specified limit. The lack of the reception sensitivity decreases the coverage area at the far side from Node B.

6.2.4 Method of test

6.2.4.1 Initial conditions

Test environment: normal; see TS34.121-1 [3] clause G.2.1.

- 1) Set the SS downlink physical channels according to settings in Table 6.2.2.
- 2) Power on the UE.
- 3) A call is set up according to the Generic call setup procedure. The power control algorithm shall be set to Power Control Algorithm 2. Compressed mode shall be set to OFF.
- 4) Enter the UE into loopback test mode 2 and start the loopback test.

See TS 34.108 [10] and TS 34.109 [11] for details regarding generic call setup procedure and loopback test.

Table 6.2.2: Downlink Physical Channels transmitted during a connection

Physical Channel	Power
CPICH	CPICH_Ec / DPCH_Ec = 7 dB
P-CCPCH	P-CCPCH_Ec / DPCH_Ec = 5 dB
SCH	SCH_Ec / DPCH_Ec = 5 dB
PICH	PICH_Ec / DPCH_Ec = 2 dB
DPCH	Test dependent power

6.2.4.2 Test procedure

- 1) Send continuously Up power control commands to the UE.
- 2) As the UE reaches maximum power, start sending PN15 data pattern.
- 3) Position the UE against the SAM phantom
- 4) Measure EIS from one measurement point. EIS is the power transmitted from one specific direction to the UE causing BER value of $1\% \pm 0.2\%$ using 20000 or more bits, see Annex E.19.1.

NOTE: To meet BER value target DL power level can be changed using user's freely selectable algorithm.

- 5) Measure the EIS for every direction of selected sampling grid using two orthogonal polarizations to obtain TRS.
- 6) Calculate TRS using equations from chapter 6.2.1

NOTE: To speed up sensitivity measurements non standard setting (i.e. data speed, PCL, BER target) can be used in the measurements. However to obtain TRS result the measured EIS figures shall be normalized by

$$\Delta \overline{EIS} = \frac{1}{n} \sum_{i=1}^n (EIS_{std_i} - EIS_{nstd_i})$$

Where EIS_{std_i} is sensitivity measurement done with standard setting. EIS_{nstd_i} is sensitivity measurement done with non standard settings. n is amount of reference measurement points.

To ensure accuracy of TRS, the amount of reference points measured should be at least 4. It is recommended to spread the reference measurements equally during the measurement time.

The measurement procedure is based on the measurement of the spherical sensitivity pattern of the DUT. The sensitivity values of the DUT at a predefined BER level are sampled in far field in a group of points located on a spherical surface enclosing the DUT. The EIS samples are taken using a constant sample step of 30° both in theta (θ) and phi (ϕ) directions. All the EIS samples are taken with two orthogonal polarizations, θ - and ϕ -polarisations. The Total Radiated Sensitivity is calculated from the measured data by equation in chapter 6.2.1.

6.2.4.3 Test procedure, reverberation chamber method

- 1) Send continuously Up power control commands to the UE.
- 2) As the UE reaches maximum power, start sending PN15 data pattern.
- 3) Position the UE against the SAM phantom
- 4) Set the base station simulator to a specific output power and perform a BER measurement.
- 5) Increase or decrease the base station output power as needed, and repeat step 5 until the lowest output power is found that gives a BER value of $1\% \pm 0.2\%$ using 20000 or more bits, see Annex E.19.1. This corresponds to

$$\left| S_{21,n,m}^{thres} \right|^2.$$

NOTE: To meet BER value target DL power level can be changed using user's freely selectable algorithm.

- 6) Repeat step 4 and 5 until a sufficient number of independent samples (see section 6.1.3) of $\left| S_{21,n,m}^{thres} \right|^2$ has been measured.
- 7) Calculate TRS using equations from chapter 6.2.1

NOTE 1: The measurement procedure is based on samples of the received signal power at the UE/MS from a full 3 dimensional isotropic environment with uniform elevation and azimuth field distribution. The power received by the DUT is undergoing Rayleigh fading and is transmitted by the fixed measurement antennas. Moreover, it is important that the samples collected are independent, in order to get sufficient accuracy of the estimated TRS value.

6.2.5 Test requirements

The average TRS of low, mid and high channel in beside head position for 1% BER with 12.2kbps DL reference channel as defined in Annex C.3 of [2] shall be lower than test requirements for roaming bands shown in Table 6.2.3. The averaging shall be done in linear scale for the TRS results of both right and left side of the phantom head.

$$TRS_{average} = 10 \log \left[6 / \left(\frac{1}{10^{P_{left_low}/10}} + \frac{1}{10^{P_{left_mid}/10}} + \frac{1}{10^{P_{left_high}/10}} + \frac{1}{10^{P_{right_low}/10}} + \frac{1}{10^{P_{right_mid}/10}} + \frac{1}{10^{P_{right_high}/10}} \right) \right]$$

In addition the maximum TRS of each measured channel in beside head position shall be better than minimum performance requirements for roaming bands shown in the columns "Max".

$$TRS_{max} = 10 \log \left[\max \left(10^{P_{left_low}/10}, 10^{P_{left_mid}/10}, 10^{P_{left_high}/10}, 10^{P_{right_low}/10}, 10^{P_{right_mid}/10}, 10^{P_{right_high}/10} \right) \right]$$

Table 6.2.3: TRS test requirements for FDD roaming bands in the speech position for the primary mechanical mode

Operating Band	Unit	<REF _{or} >	
		Average	Max
I	dBm/3.84 MHz	-100.1	-96.8
II	dBm/3.84 MHz	-98.1	-94.8
III	dBm/3.84 MHz	-97.1	-93.8
IV	dBm/3.84 MHz	-100.1	-96.8
V	dBm/3.84 MHz	-95.1	-91.8
VI	dBm/3.84 MHz	-95.1	-91.8
VII	dBm/3.84 MHz	-98.1	-94.8
VIII	dBm/3.84 MHz	-95.1	-91.8
IX	dBm/3.84 MHz	-99.1	-95.8
XIX	dBm/3.84 MHz	-95.1	-91.8
NOTE 1 For Power Class 3, 3bis and 4 this shall be achieved at the maximum output power.			
NOTE 2 For the UE which supports both Band III and Band IX operating frequencies, the reference level of TDB dBm TRS <REF _{or} > [average and min] shall apply for Band IX.			
NOTE3: Applicable for dual-mode GSM/UMTS.			

NOTE: If the above Test Requirement differs from the Minimum Requirement then the Test Tolerance applied for this test is non-zero. The Test Tolerance for this test is defined and the explanation of how the Minimum Requirement has been relaxed by the Test Tolerance is given in Annex D.

6.3 Total Radiated Sensitivity (TRS) for GSM MS

6.3.1 Definition and applicability

The Total Radiated Sensitivity is defined as:

$$TRS = \frac{4\pi}{\oint \left[\frac{1}{EIS_{\theta}(\Omega; f)} + \frac{1}{EIS_{\varphi}(\Omega; f)} \right] d\Omega}$$

Where the effective isotropic sensitivity (*EIS*) is defined as the power available at the antenna output such as the sensitivity threshold is achieved for each polarization. Ω is the solid angle describing the direction, f is frequency. θ and φ are the orthogonal polarizations.

$$TRS \approx \frac{2NM}{\pi \sum_{n=0}^{N-1} \sum_{m=0}^{M-1} \left[\frac{1}{EIS_{\theta}(\theta_n, \varphi_m; f)} + \frac{1}{EIS_{\varphi}(\theta_n, \varphi_m; f)} \right]} \sin(\theta_n)$$

In these formulas N and M are the number of sampling intervals for theta and phi. θ_n and φ_m are the measurement angles. The sampling intervals are discussed further in Section 6.1.3.

The TRS can also be calculated from measurements in a Rayleigh fading 3 dimensional isotropic environment with uniform elevation and azimuth distribution. The calculation of the TRS is in this case based on searching for the lowest power received by the UE/MS for a discrete number of field combinations in the chamber. The power received by the UE at each discrete field combination that provides a BER (or BLER) which is better than the specified target BER/BLER level shall be averaged with other such measurements using different field combinations. By calibrating the average power transfer function, an absolute value of the TRS can be obtained when the linear values of all downlink power levels described above have been averaged. The following expression can be used to find the TRS.

$$TRS \approx 2N \frac{\left(\sum_{n=1}^N (C_n (1 - R_n) P_{thres,n}) \right)^{-1}}{\sum_{n=1}^N P_{ref,n}}$$

where $P_{ref,n}$ is the reference power transfer function for fixed measurement antenna n , R_n is the reflection coefficient for fixed measurement antenna n and C_n is the path loss in the cables connecting the measurement receiver to fixed measurement antenna n . These parameters are calculated from the calibration measurement and are further discussed in Annex B.2. $P_{thres,n}$ is calculated by using the following equation:

$$P_{thres,n} = \frac{\sum_{m=1}^M \frac{1}{|S_{21,n,m}^{thres}|^2}}{M}$$

where $S_{21,n,m}^{thres}$ is the m :th value of the transfer function for fixed measurement antenna n , which gives the BER threshold. M is the total number of values of the BER threshold power measured for each fixed measurement antenna.

The requirements and this test apply to all types of MS that support GSM for Release 7 and later releases.

6.3.2 Minimum requirements

The average TRS of low, mid and high channel in beside head position for TCH/FS at 2% class II (RBER) shall be lower than minimum performance requirements for roaming bands shown in Table 6.3.1. The averaging shall be done in linear scale for the TRS results of both right and left side of the phantom head.

$$TRS_{average} = 10 \log \left[6 / \left(\frac{1}{10^{P_{left_low}/10}} + \frac{1}{10^{P_{left_mid}/10}} + \frac{1}{10^{P_{left_high}/10}} + \frac{1}{10^{P_{right_low}/10}} + \frac{1}{10^{P_{right_mid}/10}} + \frac{1}{10^{P_{right_high}/10}} \right) \right]$$

In addition the maximum TRS of each measured channel in beside head position shall be better than minimum performance requirements for roaming bands shown in the columns "Max".

$$TRS_{max} = 10 \log \left[\max \left(10^{P_{left_low}/10}, 10^{P_{left_mid}/10}, 10^{P_{left_high}/10}, 10^{P_{right_low}/10}, 10^{P_{right_mid}/10}, 10^{P_{right_high}/10} \right) \right]$$

Table 6.3.1: TRS minimum requirements for GSM roaming bands in the speech position for the primary mechanical mode

Operating Band	Unit	<REF _{or} >	
		Average	Max
GSM 850	dBm	-98	-95
GSM 900	dBm	-97	-94
DCS 1800	dBm	-99.5	-96.5
PCS 1900	dBm	-98.5	-95.5
Note 1: For Power Class 1 and 4 this shall be achieved at the maximum output power.			
Note 2: Applicable for dual-mode GSM/UMTS.			

The normative reference for this clause is TS25.144 section 7.2.2.

6.3.3 Test Purpose

The purpose of this test is to ensure that $TRS_{average}$ and TRS_{max} of the MS is above specified limit. The lack of the reception sensitivity decreases the coverage area at the far side from Base Station.

6.3.4 Method of test

6.3.4.1 Initial conditions

Test environment: normal condition; see TS51.010-1 [9] Annex A1.2.2.

A call is set up according to the generic call set up procedure on a TCH/FS with an ARFCN in the Mid ARFCN range, power control level set to maximum power.

The SS transmits Standard Test Signal C1 on the traffic channel, see TS51.010-1 [9] Annex A5.2.

The SS commands the MS to create traffic channel loop back signalling erased frames, see TS44.014 [34] clause 5.1.2.

6.3.4.2 Test procedure

- 1) Position the MS against the SAM phantom
- 2) The SS compares the data of the signal that it sends to the MS with the signal which is looped back from the receiver after demodulation and decoding, and checks the frame erasure indication.
- 3) The SS determines the number of residual bit error events for the bits of class II, by examining sequences of at least the minimum number of samples of consecutive bits of class II. Bits are taken only from those frames not signalled as erased.
- 4) Measure EIS from one measurement point. EIS is the power transmitted from one specific direction to the MS causing RBERII value of $2.00\% \pm 0.2\%$, see Annex E.19.2

NOTE: To meet BER value target DL power level can be changed using user's freely selectable algorithm.

- 5) Measure the EIS for every direction of selected sampling grid using two orthogonal polarizations to obtain TRS.
- 6) Calculate TRS using equations from chapter 6.3.1.
- 7) Steps 1) to 6) are repeated for TCH/FS with ARFCNs in the Low ARFCN range and the High ARFCN range.

NOTE 2: Non standard settings:

To speed up sensitivity measurements non standard setting (i.e. data speed, PCL, BER target) can be used in the measurements. However to obtain TRS result the measured EIS figures shall be normalized by

$$\overline{\Delta EIS} = \frac{1}{n} \sum_{i=1}^n (EISstd_i - EISnstd_i)$$

Where $EISstd_i$ is sensitivity measurement done with standard setting. $EISnstd_i$ is sensitivity measurement done with non standard settings. n is amount of reference measurement points.

To ensure accuracy of TRS, the amount of reference points measured should be at least 4. It is recommended to spread the reference measurements equally during the measurement time.

The measurement procedure is based on the measurement of the spherical sensitivity pattern of the DUT. The sensitivity values of the DUT at a predefined BER level are sampled in far field in a group of points located on a closed surface enclosing the DUT. The EIS samples are taken using a constant sample step of 30° both in theta (θ) and phi (ϕ) directions. All the EIS samples are taken with two orthogonal polarizations, θ - and ϕ -polarisations. The Total Radiated Sensitivity is calculated from the measured data by equation in chapter 6.3.1.

6.3.4.3 Test procedure, reverberation chamber method

- 1) Position the UE against the SAM phantom
- 2) The SS compares the data of the signal that it sends to the MS with the signal which is looped back from the receiver after demodulation and decoding, and checks the frame erasure indication.
- 3) The SS determines the number of residual bit error events for the bits of class II, by examining sequences of at least the minimum number of samples of consecutive bits of class II. Bits are taken only from those frames not signalled as erased.
- 4) Set the base station simulator to a specific output power and perform a BER measurement.
- 5) Increase or decrease the base station output power as needed, and repeat step 5 until the lowest output power is found that gives a BER value of $2.00\% \pm 0.2\%$, see Annex E.19.2. This corresponds to $\left| S_{21,n,m}^{thres} \right|^2$.

NOTE: To meet BER value target DL power level can be changed using user's freely selectable algorithm.

- 6) Repeat step 4 and 5 until a sufficient number of independent samples (see section 6.1.3) of $\left| S_{21,n,m}^{thres} \right|^2$ has been measured.
- 7) Calculate TRS using equations from chapter 6.3.1
- 8) Steps 1) to 7) are repeated for TCH/FS with ARFCNs in the Low ARFCN range and the High ARFCN range.

NOTE 1: The measurement procedure is based on samples of the received signal power at the UE/MS from a full 3 dimensional isotropic environment with uniform elevation and azimuth field distribution. The power received by the DUT is undergoing Rayleigh fading and is transmitted by the fixed measurement antennas. Moreover, it is important that the samples collected are independent, in order to get sufficient accuracy of the estimated TRS value.

6.3.5 Test requirements

The average TRS of low, mid and high channel in beside head position for TCH/FS at 2% class II (RBER) shall be lower than test requirements for roaming bands shown in Table 6.3.2. The averaging shall be done in linear scale for the TRS results of both right and left side of the phantom head.

$$TRS_{average} = 10 \log \left[6 / \left(\frac{1}{10^{P_{left_low}/10}} + \frac{1}{10^{P_{left_mid}/10}} + \frac{1}{10^{P_{left_high}/10}} + \frac{1}{10^{P_{right_low}/10}} + \frac{1}{10^{P_{right_mid}/10}} + \frac{1}{10^{P_{right_high}/10}} \right) \right]$$

In addition the maximum TRS of each measured channel in beside head position shall be better than minimum performance requirements for roaming bands shown in the columns "Max".

$$TRS_{max} = 10 \log \left[\max \left(10^{P_{left_low}/10}, 10^{P_{left_mid}/10}, 10^{P_{left_high}/10}, 10^{P_{right_low}/10}, 10^{P_{right_mid}/10}, 10^{P_{right_high}/10} \right) \right]$$

Table 6.3.2: TRS test requirements for GSM roaming bands in the speech position for the primary mechanical mode

Operating Band	Unit	<REF _{or} >	
		Average	Max
GSM 850	dBm	-97.1	-93.8
P-GSM 900	dBm	-96.1	-92.8
E-GSM 900	dBm	-96.1	-92.8
DCS 1800	dBm	-98.6	-95.3
PCS 1900	dBm	-97.6	-94.3

Note 1: For Power Class 1 and 4 this shall be achieved at the maximum output power.
Note 2: Applicable for dual-mode GSM/UMTS.
Note 3: The test requirements for E-GSM 900 and P-GSM 900 are specified from GSM 900 minimum requirements in table 6.3.1.

NOTE: If the above Test Requirement differs from the Minimum Requirement then the Test Tolerance applied for this test is non-zero. The Test Tolerance for this test is defined and the explanation of how the Minimum Requirement has been relaxed by the Test Tolerance is given in Annex D.

6.4 Total Radiated Sensitivity (TRS) for TDD UE

6.4.1 Definition and applicability

The Total Radiated Sensitivity is defined as:

$$TRS = \frac{4\pi}{\oint \left[\frac{1}{EIS_{\theta}(\Omega; f)} + \frac{1}{EIS_{\varphi}(\Omega; f)} \right] d\Omega}$$

Where the effective isotropic sensitivity (*EIS*) is defined as the power available at the antenna output such as the sensitivity threshold is achieved for each polarization. Ω is the solid angle describing the direction, f is frequency. θ and φ are the orthogonal polarizations.

$$TRS \approx \frac{2NM}{\pi \sum_{n=0}^{N-1} \sum_{m=0}^{M-1} \left[\frac{1}{EIS_{\theta}(\theta_n, \varphi_m; f)} + \frac{1}{EIS_{\varphi}(\theta_n, \varphi_m; f)} \right] \sin(\theta_n)}$$

In these formulas N and M are the number of sampling intervals for theta and phi. θ_n and φ_m are the measurement angles. The sampling intervals are discussed further in Section 6.1.2.

The TRS can also be calculated from measurements in a Rayleigh fading 3 dimensional isotropic environment with uniform elevation and azimuth distribution. The calculation of the TRS is in this case based on searching for the lowest power received by the UE/MS for a discrete number of field combinations in the chamber. The power received by the UE at each discrete field combination that provides a BER (or BLER) which is better than the specified target BER/BLER level shall be averaged with other such measurements using different field combinations. By calibrating the average power transfer function, an absolute value of the TRS can be obtained when the linear values of all downlink power levels described above have been averaged. The following expression can be used to find the TRS.

$$TRS \approx 2N \frac{\left(\sum_{n=1}^N (C_n (1 - R_n) P_{thres,n}) \right)^{-1}}{\sum_{n=1}^N P_{ref,n}}$$

where $P_{ref,n}$ is the reference power transfer function for fixed measurement antenna n, R_n is the reflection coefficient for fixed measurement antenna n and C_n is the path loss in the cables connecting the measurement receiver to fixed measurement antenna n. These parameters are calculated from the calibration measurement and are further discussed in Annex B.2. $P_{thres,n}$ is calculated by using the following equation:

$$P_{thres,n} = \frac{\sum_{m=1}^M \frac{1}{|S_{21,n,m}^{thres}|^2}}{M}$$

where $S_{21,n,m}^{thres}$ is the m:th value of the transfer function for fixed measurement antenna n, which gives the BER threshold. M is the total number of values of the BER threshold power measured for each fixed measurement antenna.

The requirements and this test apply to all types of UTRA for the TDD UE for Release 8 and later releases.

6.4.2 Minimum requirements

The average TRS of low, mid and high channel in beside head position for $1\% \pm 0.2\%$ BER with 12.2kbps DL reference channel as defined in Annex C.3 of TS25.101 [2] shall be lower than minimum performance requirements for roaming bands shown in Table 6.4.1. The averaging shall be done in linear scale for the TRS results of both right and left side of the phantom head.

$$TRS_{average} = 10 \log \left[6 / \left(\frac{1}{10^{P_{left_low}/10}} + \frac{1}{10^{P_{left_mid}/10}} + \frac{1}{10^{P_{left_high}/10}} + \frac{1}{10^{P_{right_low}/10}} + \frac{1}{10^{P_{right_mid}/10}} + \frac{1}{10^{P_{right_high}/10}} \right) \right]$$

In addition the maximum TRS of each measured channel in beside head position shall be better than minimum performance requirements for roaming bands shown in the columns "Max".

$$TRS_{max} = 10 \log \left[\max \left(10^{P_{left_low}/10}, 10^{P_{left_mid}/10}, 10^{P_{left_high}/10}, 10^{P_{right_low}/10}, 10^{P_{right_mid}/10}, 10^{P_{right_high}/10} \right) \right]$$

Table 6.4.1: TRS minimum requirement for UTRA LCR TDD roaming bands in the speech position for the primary mechanical mode

Operating Band	Unit	<REFlor>	
		Average	Max
-	-		
a	dBm/1.28 MHz	-101	-100
b	dBm/1.28 MHz	TBD	TBD
c	dBm/1.28 MHz	TBD	TBD
d	dBm/1.28 MHz	TBD	TBD
e	dBm/1.28 MHz	-101	-100
f	dBm/1.28 MHz	-101	-100

Note: Applicable for dual-mode GSM/UTRA LCR TDD.

The normative reference for this clause is TS 25.144 section 7.2.3.

6.4.3 Test Purpose

The purpose of this test is to ensure that $TRS_{average}$ and TRS_{max} of the UE are above specified limit. The lack of the reception sensitivity decreases the coverage area at the far side from Node B.

6.4.4 Method of test

6.4.4.1 Initial conditions

Test environment: normal; see TS34.122 [13] clause G.2.1.

- 1) Set the SS downlink physical channels according to settings in Table 6.4.1A. The DL power level should be set to ensure 0% BER at 12.2kbps data rate at the whole 3D initial scan.
- 2) Power on the UE.
- 3) A call is set up according to the Generic call setup procedure. The power control algorithm shall be set to Power Control Algorithm 2.
- 4) Enter the UE into loopback test mode and start the loopback test.

See TS 34.108 [10] and TS 34.109 [11] and Annex C of TS 34.122[13]. For details regarding generic call setup procedure and loopback test.

Table 6.4.1A: Downlink Physical Channels transmitted during a connection

Physical Channel	Power
lor	-75 dBm
DwPCH	DwPCH_Ec / lor = 0 dB
PCCPCH	$\sum P\text{-CCPCH_Ec} / \text{lor} = -3$ dB
SCCPCH	$\sum S\text{-CCPCH_Ec} / \text{lor} = -6$ dB
PICH	$\sum \text{PICH_Ec} / \text{lor} = -6$ dB
FPACH	FPACH_Ec / lor = -6 dB
DL DPCH	$\sum \text{DPCH_Ec} / \text{lor} = 0$ dB

6.4.4.2 Test procedure

- 1) Send continuously Up power control commands to the UE.
- 2) As the UE reaches maximum power, start sending PN15 data pattern.
- 3) Position the UE against the SAM phantom.
- 4) Measure EIS from one measurement point. EIS is the power transmitted from one specific direction to the UE causing BER value of $1\% \pm 0.2\%$ using 40000 or more bits, see Annex E.19.3. The DL power step size shall be no bigger than 0.5dB when the RF level is near the TDD UE sensitivity level.

NOTE: To meet BER value target DL power level can be changed using user's freely selectable algorithm.

- 5) Measure the EIS for every direction of selected sampling grid using two orthogonal polarizations to obtain TRS.
- 6) Calculate TRS using equations from chapter 6.4.1

NOTE: To speed up sensitivity measurements non standard setting (i.e. data speed, PCL, BER target) can be used in the measurements. However to obtain TRS result the measured EIS figures shall be normalized by

$$\overline{\Delta EIS} = \frac{1}{n} \sum_{i=1}^n (EISstd_i - EISnstd_i)$$

Where $EISstd_i$ is sensitivity measurement done with standard setting. $EISnstd_i$ is sensitivity measurement done with non standard settings. n is amount of reference measurement points.

To ensure accuracy of TRS, the amount of reference points measured should be at least 4. It is recommended to spread the reference measurements equally during the measurement time.

The measurement procedure is based on the measurement of the spherical sensitivity pattern of the DUT. The sensitivity values of the DUT at a predefined BER level are sampled in far field in a group of points located on a

spherical surface enclosing the DUT. The EIS samples are taken using a constant sample step of 30° both in theta (θ) and phi (ϕ) directions. All the EIS samples are taken with two orthogonal polarizations, θ - and φ -polarisations. The Total Radiated Sensitivity is calculated from the measured data by equation in chapter 6.4.1.

6.4.4.3 Test procedure, reverberation chamber method

- 1) Send continuously Up power control commands to the UE.
- 2) As the UE reaches maximum power, start sending PN15 data pattern.
- 3) Position the UE against the SAM phantom
- 4) Set the base station simulator to a specific output power and perform a BER measurement.
- 5) Increase or decrease the base station output power as needed, and repeat step 5 until the lowest output power is found that gives a BER value of $1\% \pm 0.2\%$ using 40000 or more bits, see Annex E.19.3. This corresponds to $\left|S_{21,n,m}^{thres}\right|^2$. The DL power step size shall be no bigger than 0.5dB when the RF level is near the TDD UE sensitivity level.

NOTE: To meet BER value target DL power level can be changed using user's freely selectable algorithm.

- 6) Repeat step 4 and 5 until a sufficient number of independent samples (see section 6.1.3) of $\left|S_{21,n,m}^{thres}\right|^2$ has been measured.
- 7) Calculate TRS using equations from chapter 6.4.1

NOTE 1: The measurement procedure is based on samples of the received signal power at the UE/MS from a full 3 dimensional isotropic environment with uniform elevation and azimuth field distribution. The power received by the DUT is undergoing Rayleigh fading and is transmitted by the fixed measurement antennas. Moreover, it is important that the samples collected are independent, in order to get sufficient accuracy of the estimated TRS value.

6.4.5 Test requirements

The average TRS of low, mid and high channel in beside head position for $1\% \pm 0.2\%$ BER with 12.2kbps DL reference channel as defined in Annex C.3 of TS25.101 [2] shall be lower than test requirements for roaming bands shown in Table 6.4.2. The averaging shall be done in linear scale for the TRS results of both right and left side of the phantom head.

$$TRS_{average} = 10 \log \left[6 / \left(\frac{1}{10^{P_{left_low}/10}} + \frac{1}{10^{P_{left_mid}/10}} + \frac{1}{10^{P_{left_high}/10}} + \frac{1}{10^{P_{right_low}/10}} + \frac{1}{10^{P_{right_mid}/10}} + \frac{1}{10^{P_{right_high}/10}} \right) \right]$$

In addition the maximum TRS of each measured channel in beside head position shall be better than minimum performance requirements for roaming bands shown in the columns "Max".

$$TRS_{max} = 10 \log \left[\max \left(10^{P_{left_low}/10}, 10^{P_{left_mid}/10}, 10^{P_{left_high}/10}, 10^{P_{right_low}/10}, 10^{P_{right_mid}/10}, 10^{P_{right_high}/10} \right) \right]$$

Table 6.4.2: TRS test requirement for UTRA LCR TDD roaming bands in the speech position for the primary mechanical mode

Operating Band	Unit	<REFlor>	
		Average	Max
-	-	-100.1	-98.8
a	dBm/1.28 MHz	-100.1	-98.8
b	dBm/1.28 MHz	TBD	TBD
c	dBm/1.28 MHz	TBD	TBD
d	dBm/1.28 MHz	TBD	TBD
e	dBm/1.28 MHz	-100.1	-98.8
f	dBm/1.28 MHz	-100.1	-98.8

Note: Applicable for dual-mode GSM/UTRA LCR TDD.

NOTE: If the above Test Requirement differs from the Minimum Requirement then the Test Tolerance applied for this test is non-zero. The Test Tolerance for this test is defined and the explanation of how the Minimum Requirement has been relaxed by the Test Tolerance is given in Annex D.

6.5 Total Radiated Sensitivity (TRS) for FDD UE using LME

Editor's note: This test case is incomplete. The following aspects are either missing or not yet determined:

- The TRS Minimum Performance Requirement for this test are undefined
- The Test Requirements and related Test Tolerances applicable for this test are undefined

6.5.1 Definition and applicability

The Total Radiated Sensitivity (TRS) is a measure of the minimum power required to achieve a specified Bit Error Rate (BER). The TRS is defined as:

$$TRS = \frac{4\pi}{\oint \left[\frac{1}{EIS_{\theta}(\Omega; f)} + \frac{1}{EIS_{\varphi}(\Omega; f)} \right] d\Omega}$$

Where the effective isotropic sensitivity (*EIS*) is defined as the power available at the antenna output such as the sensitivity threshold is achieved for each polarization. Ω is the solid angle describing the direction, f is frequency. θ and φ are the orthogonal polarizations.

$$TRS \approx \frac{2NM}{\pi \sum_{n=0}^{N-1} \sum_{m=0}^{M-1} \left[\frac{1}{EIS_{\theta}(\theta_n, \varphi_m; f)} + \frac{1}{EIS_{\varphi}(\theta_n, \varphi_m; f)} \right] \sin(\theta_n)}$$

In these formulas N and M are the number of sampling intervals for theta and phi. θ_n and φ_m are the measurement angles. The sampling intervals are discussed further in Section 6.1.2.

The TRS can also be calculated from measurements in a Rayleigh fading 3 dimensional isotropic environment with in average uniform elevation and azimuth distribution. The calculation of the TRS is in this case based on searching for the lowest power received by the LME for a discrete number of field combinations in the chamber that gives a BER that is better than the specified target BER level. By calibrating the average power transfer function, an absolute value of the TRS can be obtained. The following expression can be used to find the TRS.

$$TRS \approx 2N \frac{\left(\sum_{n=1}^N (C_n (1 - R_n) P_{thres,n}) \right)^{-1}}{\sum_{n=1}^N P_{ref,n}}$$

where $P_{ref,n}$ is the reference power transfer function for fixed measurement antenna n, R_n is the reflection coefficient for fixed measurement antenna n and C_n is the path loss in the cables connecting the measurement receiver to fixed measurement antenna n. These parameters are calculated from the calibration measurement and are further discussed in Annex B.2. $P_{thres,n}$ is calculated by using the following equation:

$$P_{thres,n} = \frac{\sum_{m=1}^M \frac{1}{|S_{21,n,m}^{thres}|^2}}{M}$$

where $S_{21,n,m}^{thres}$ is the m:th value of the transfer function for fixed measurement antenna n, which gives the BER threshold. M is the total number of values of the BER threshold power measured for each fixed measurement antenna.

The requirements and this test apply to all types of UTRA for the FDD UE for Release 11 and later releases that support LME.

NOTE: This test case can be optionally executed for Release 7 and onward UE's supporting LME feature.

6.5.2 Minimum Requirements

The average TRS of low, mid and high channel for 1% BER with 12.2kbps DL reference channel as defined in Annex C.3 of TS25.101 [2] shall be lower than minimum performance requirements for roaming bands shown in Table 6.5.1. The averaging shall be done in linear scale for the TRS results.

$$TRS_{average} = 10 \log \left[3 / \left(\frac{1}{10^{P_{low}/10}} + \frac{1}{10^{P_{mid}/10}} + \frac{1}{10^{P_{high}/10}} \right) \right]$$

In addition the maximum TRS of each measured channel shall be better than minimum performance requirements for roaming bands shown in the columns "Max".

$$TRS_{max} = 10 \log \left[\max \left(10^{P_{low}/10}, 10^{P_{mid}/10}, 10^{P_{high}/10} \right) \right]$$

Table 6.5.1: TRS minimum requirements for FDD LME devices in data transfer position

Operating Band	Unit	<REF _{or} >	
		Average	Max
I	dBm/3.84 MHz	TBD	TBD
II	dBm/3.84 MHz	TBD	TBD
III	dBm/3.84 MHz	TBD	TBD
IV	dBm/3.84 MHz	TBD	TBD
V	dBm/3.84 MHz	TBD	TBD
VI	dBm/3.84 MHz	TBD	TBD
VII	dBm/3.84 MHz	TBD	TBD
VIII	dBm/3.84 MHz	TBD	TBD
IX	dBm/3.84 MHz	TBD	TBD
IX	dBm/3.84 MHz	TBD	TBD

NOTE 1 For Power Class 3, 3bis and 4 this shall be achieved at the maximum output power.
NOTE 2 Applicable for dual-mode GSM/UMTS.
NOTE 3 Applicable for USB plug-in devices.

The normative reference for this clause is TS25.144 [12] section 7.3.1.1.

6.5.3 Test purpose

The purpose of this test is to ensure that $TRS_{average}$ and TRS_{max} of the UE is above specified limit. The lack of the reception sensitivity decreases the coverage area at the far side from Node B.

6.5.4 Method of test

6.5.4.1 Initial conditions

Test environment: normal; see TS 34.121-1 [3] clause G.2.1.

- 1) Set the SS downlink physical channels according to settings in Table 6.5.2.
- 2) Connect the plug-in UE to a laptop ground plane phantom. Power on the plug-in UE. The real functional laptop supplies power to the plug-in UE.
- 3) A call is set up according to the Generic call setup procedure. The power control algorithm shall be set to Power Control Algorithm 2. Compressed mode shall be set to OFF.
- 4) Enter the UE into loopback test mode 2 and start the loopback test.

See TS 34.108 [10] and TS 34.109 [11] for details regarding generic call setup procedure and loopback test.

Table 6.5.2: Downlink Physical Channels transmitted during a connection

Physical Channel	Power
CPICH	CPICH_Ec / DPCH_Ec = 7 dB
P-CCPCH	P-CCPCH_Ec / DPCH_Ec = 5 dB
SCH	SCH_Ec / DPCH_Ec = 5 dB
PICH	PICH_Ec / DPCH_Ec = 2 dB
DPCH	Test dependent power

6.5.4.2 Procedure

- 1) Send continuously Up power control commands to the plug-in UE.
- 2) As the plug-in UE reaches maximum power, start sending PN15 data pattern.
- 3) Position the plug-in UE into the USB connector in accordance with the manufacturer recommended primary mechanical mode. In the absence of such a recommendation position the plug-in UE so that it is horizontally plugged into the horizontal USB connector.
- 4) Measure EIS from one measurement point. EIS is the power transmitted from one specific direction to the plug-in UE causing BER value of $1\% \pm 0.2\%$ using 20000 or more bits, see Annex E.19.1.

NOTE: To meet BER value target DL power level can be changed using user's freely selectable algorithm.

- 5) Measure the EIS for every direction of selected sampling grid using two orthogonal polarizations to obtain TRS.
- 6) Calculate TRS using equations from clause 6.5.1

NOTE: To speed up sensitivity measurements non standard setting (i.e. data speed, PCL, BER target) can be used in the measurements. However to obtain TRS result the measured EIS figures shall be normalized by

$$\overline{\Delta EIS} = \frac{1}{n} \sum_{i=1}^n (EISstd_i - EISnstd_i)$$

Where $EISstd_i$ is sensitivity measurement done with standard setting. $EISnstd_i$ is sensitivity measurement done with non standard settings. n is amount of reference measurement points.

To ensure accuracy of TRS, the amount of reference points measured should be at least 4. It is recommended to spread the reference measurements equally during the measurement time.

The measurement procedure is based on the measurement of the spherical sensitivity pattern of the DUT. The sensitivity values of the DUT at a predefined BER level are sampled in far field in a group of points located on a spherical surface enclosing the DUT. The EIS samples are taken using a constant sample step of 30° both in theta (θ) and phi (ϕ) directions. All the EIS samples are taken with two orthogonal polarizations, θ - and φ -polarisations. The Total Radiated Sensitivity is calculated from the measured data by equation in clause 6.5.1.

6.5.4.3 Test procedure, reverberation chamber method

- 1) Send continuously Up power control commands to the plug-in UE.
- 2) As the plug-in UE reaches maximum power, start sending PN15 data pattern.
- 3) Position the plug-in UE into the USB connector in accordance with the manufacturer recommended primary mechanical mode. In the absence of such a recommendation position the plug-in UE so that it is horizontally plugged into the horizontal USB connector.
- 4) Set the base station simulator to a specific output power and perform a BER measurement.
- 5) Increase or decrease the base station output power as needed, and repeat step 5 until the lowest output power is found that gives a BER value of $1\% \pm 0.2\%$ using 20000 or more bits, see Annex E.19.1. This corresponds to

$$\left| S_{21,n,m}^{thres} \right|^2.$$

NOTE 1: To meet BER value target DL power level can be changed using user's freely selectable algorithm.

- 6) Repeat step 4 and 5 until a sufficient number of independent samples (see section 6.1.3) of $\left| S_{21,n,m}^{thres} \right|^2$ has been measured.
- 7) Calculate TRS using equations from clause 6.5.1

NOTE 2: The measurement procedure is based on samples of the received signal power at the UE/MS from a full 3 dimensional isotropic environment with uniform elevation and azimuth field distribution. The power received by the DUT is undergoing Rayleigh fading and is transmitted by the fixed measurement antennas. Moreover, it is important that the samples collected are independent, in order to get sufficient accuracy of the estimated TRS value.

6.5.5 Test requirements

The average TRS of low, mid and high channel for 1% BER with 12.2kbps DL reference channel as defined in Annex C.3 of [2] shall be lower than test requirements for roaming bands shown in Table 6.5.3. The averaging shall be done in linear scale for the TRS results.

$$TRS_{average} = 10 \log \left[3 / \left(\frac{1}{10^{P_{low}/10}} + \frac{1}{10^{P_{mid}/10}} + \frac{1}{10^{P_{high}/10}} \right) \right]$$

In addition the maximum TRS of each measured channel shall be better than minimum performance requirements for roaming bands shown in the columns "Max".

$$TRS_{max} = 10 \log \left[\max \left(10^{P_{low}/10}, 10^{P_{mid}/10}, 10^{P_{high}/10} \right) \right]$$

Table 6.5.3: TRS test requirements for FDD LME devices in data transfer position

Operating Band	Unit	<REF _{or} >	
		Average	Max
I	dBm/3.84 MHz	TBD + TT	TBD + TT
II	dBm/3.84 MHz	TBD + TT	TBD + TT
III	dBm/3.84 MHz	TBD + TT	TBD + TT
IV	dBm/3.84 MHz	TBD + TT	TBD + TT
V	dBm/3.84 MHz	TBD + TT	TBD + TT
VI	dBm/3.84 MHz	TBD + TT	TBD + TT
VII	dBm/3.84 MHz	TBD + TT	TBD + TT
VIII	dBm/3.84 MHz	TBD + TT	TBD + TT
IX	dBm/3.84 MHz	TBD + TT	TBD + TT
XIX	dBm/3.84 MHz	TBD + TT	TBD + TT

NOTE 1 For Power Class 3, 3bis and 4 this shall be achieved at the maximum output power.
NOTE 2 Applicable for dual-mode GSM/UMTS.
NOTE 3 Applicable for USB plug-in devices.

NOTE: If the above Test Requirement differs from the Minimum Requirement then the Test Tolerance applied for this test is non-zero. The Test Tolerance for this test is defined and the explanation of how the Minimum Requirement has been relaxed by the Test Tolerance is given in Annex D.

6.6 Total Radiated Sensitivity (TRS) for GSM MS using LME

Editor's note: This test case is not completed

Minimum Requirements are missing

Test requirements and related TT are missing

6.6.1 Definition and applicability

The Total Radiated Sensitivity is defined as:

$$TRS = \frac{4\pi}{\int \left[\frac{1}{EIS_{\theta}(\Omega; f)} + \frac{1}{EIS_{\varphi}(\Omega; f)} \right] d\Omega}$$

Where the effective isotropic sensitivity (*EIS*) is defined as the power available at the antenna output such as the sensitivity threshold is achieved for each polarization. Ω is the solid angle describing the direction, f is frequency. θ and φ are the orthogonal polarizations.

$$TRS \approx \frac{2NM}{\pi \sum_{n=0}^{N-1} \sum_{m=0}^{M-1} \left[\frac{1}{EIS_{\theta}(\theta_n, \varphi_m; f)} + \frac{1}{EIS_{\varphi}(\theta_n, \varphi_m; f)} \right] \sin(\theta_n)}$$

In these formulas N and M are the number of sampling intervals for theta and phi. θ_n and φ_m are the measurement angles. The sampling intervals are discussed further in Section 6.1.3.

The TRS can also be calculated from measurements in a Rayleigh fading 3 dimensional isotropic environment with uniform elevation and azimuth distribution. The calculation of the TRS is in this case based on searching for the lowest power received by the LME for a discrete number of field combinations in the chamber. The power received by the UE at each discrete field combination that provides a BLER which is better than the specified target BLER level shall be averaged with other such measurements using different field combinations. By calibrating the average power transfer function, an absolute value of the TRS can be obtained when the linear values of all downlink power levels described above have been averaged. The following expression can be used to find the TRS.

$$TRS \approx 2N \frac{\left(\sum_{n=1}^N (C_n (1 - R_n) P_{thres,n}) \right)^{-1}}{\sum_{n=1}^N P_{ref,n}}$$

where $P_{ref,n}$ is the reference power transfer function for fixed measurement antenna n , R_n is the reflection coefficient for fixed measurement antenna n and C_n is the path loss in the cables connecting the measurement receiver to fixed measurement antenna n . These parameters are calculated from the calibration measurement and are further discussed in Annex B.2. $P_{thres,n}$ is calculated by using the following equation:

$$P_{thres,n} = \frac{\sum_{m=1}^M \frac{1}{|S_{21,n,m}^{thres}|^2}}{M}$$

where $S_{21,n,m}^{thres}$ is the m :th value of the transfer function for fixed measurement antenna n , which gives the BLER threshold. M is the total number of values of the BLER threshold power measured for each fixed measurement antenna.

The requirements and this test apply to all types of LME that support GSM for Release 11 and later releases.

NOTE: This test case can be optionally executed for Release 7 and onward MS's supporting LME feature.

6.6.2 Minimum requirements

The average TRS of low, mid and high channel of the LME in the data transfers position for GPRS PDTCH/CS1 at 10% BLER shall be lower than minimum performance requirements for roaming bands shown in Table 6.6.1. The averaging shall be done in linear scale for the TRS results.

$$TRS_{average} = 10 \log \left[3 / \left(\frac{1}{10^{P_{low}/10}} + \frac{1}{10^{P_{mid}/10}} + \frac{1}{10^{P_{high}/10}} \right) \right]$$

In addition the maximum TRS of each measured channel in the data transfers position shall be better than minimum performance requirements for roaming bands shown in the columns "Max".

$$TRS_{max} = 10 \log \left[\max \left(10^{P_{low}/10}, 10^{P_{mid}/10}, 10^{P_{high}/10} \right) \right]$$

Table 6.6.1: TRS minimum requirements for GSM LME devices in data transfers position

Operating Band	Unit	<REF _{or} >	
		Average	Max
GSM 850	dBm	TBD	TBD
GSM 900	dBm	TBD	TBD
DCS 1800	dBm	TBD	TBD
PCS 1900	dBm	TBD	TBD
NOTE 1: For Power Class 1 and 4 this shall be achieved at the maximum output power.			
NOTE 2: Applicable for dual-mode GSM/UMTS.			
NOTE 3: Applicable for USB plug-in devices.			

The normative reference for this clause is TS25.144 section 73.1.2.

6.6.3 Test Purpose

The purpose of this test is to ensure that $TRS_{Average}$ and TRS_{max} of the MS is above specified limit. The lack of the reception sensitivity decreases the coverage area at the far side from Base Station.

6.6.4 Method of test

6.6.4.1 Initial conditions

Test environment: normal condition; see TS51.010-1 [9] Annex A1.2.2.

A call is set up according to the procedure on a GPRS PDTCH/CS1 with an ARFCN in the Mid ARFCN range, power control level set to maximum power.

The SS transmits Standard Test Signal C1 on the traffic channel, see TS51.010-1 [9] Annex A5.2.

The SS commands the MS to create traffic channel loop back, see TS44.014 [34] clause 5.4.

The LME shall be tested using the Laptop Ground Plane Phantom as described in Annex A.1.2.

6.6.4.2 Test procedure

- 1) Position the LME using the Laptop Ground Plane Phantom described in Annex A.1.2 and according to DUT positioning described in clause 6.1.1.
- 2) The SS compares the data of the signal that it sends to the MS with the signal which is looped back from the receiver after demodulation and decoding.
- 3) The SS determines the number of block error events, by examining sequences of at least the minimum number of samples of consecutive blocks.
- 4) Measure EIS from one measurement point. EIS is the power transmitted from one specific direction to the MS causing BLER value of $10\% \pm 2\%$, see Annex E.19.2

NOTE: To meet BLER value target DL power level can be changed using user's freely selectable algorithm.

- 5) Measure the EIS for every direction of selected sampling grid using two orthogonal polarizations to obtain TRS.
- 6) Calculate TRS using equations from clause 6.6.1
- 7) Steps 1) to 6) are repeated for GPRS PDTCH/CS1 with ARFCNs in the Low ARFCN range and the High ARFCN range.

NOTE 2: Non standard settings:

To speed up sensitivity measurements non standard setting (i.e. data speed, PCL, BLER target) can be used in the measurements. However to obtain TRS result the measured EIS figures shall be normalized by

$$\overline{\Delta EIS} = \frac{1}{n} \sum_{i=1}^n (EISstd_i - EISnstd_i)$$

Where $EISstd_i$ is sensitivity measurement done with standard setting. $EISnstd_i$ is sensitivity measurement done with non standard settings. n is a amount of reference measurement points.

To ensure accuracy of TRS, the amount of reference points measured should be at least 4. It is recommended to spread the reference measurements equally during the measurement time.

The measurement procedure is based on the measurement of the spherical sensitivity pattern of the DUT. The sensitivity values of the DUT at a predefined BLER level are sampled in far field in a group of points located on a closed surface enclosing the DUT. The EIS samples are taken using a constant sample step of 30° both in theta (θ)

and phi (ϕ) directions. All the EIS samples are taken with two orthogonal polarizations, θ - and φ -polarisations. The Total Radiated Sensitivity is calculated from the measured data by equation in clause 6.6.1.

6.6.4.3 Test procedure, reverberation chamber method

- 1) Position the LME using the Laptop Ground Plane Phantom described in annex A.1.2 and according to DUT positioning described in clause 6.1.1
- 2) The SS compares the data of the signal that it sends to the MS with the signal which is looped back from the receiver after demodulation and decoding.
- 3) The SS determines the number of block error events, by examining sequences of at least the minimum number of samples of consecutive blocks.
- 4) Set the base station simulator to a specific output power and perform a BLER measurement.
- 5) Increase or decrease the base station output power as needed, and repeat step 5 until the lowest output power is found that gives a BLER value of $10\% \pm 2\%$, see Annex E.19.2. This corresponds to $\left| S_{21,n,m}^{thres} \right|^2$.

NOTE: To meet BLER value target DL power level can be changed using user's freely selectable algorithm.

- 6) Repeat step 4 and 5 until a sufficient number of independent samples (see section 6.1.3) of $\left| S_{21,n,m}^{thres} \right|^2$ has been measured.
- 7) Calculate TRS using equations from clause 6.6.1
- 8) Steps 1) to 7) are repeated for GPRS PDTCH/CS1 with ARFCNs in the Low ARFCN range and the High ARFCN range.

NOTE 1: The measurement procedure is based on samples of the received signal power at the UE/MS from a full 3 dimensional isotropic environment with uniform elevation and azimuth field distribution. The power received by the DUT is undergoing Rayleigh fading and is transmitted by the fixed measurement antennas. Moreover, it is important that the samples collected are independent, in order to get sufficient accuracy of the estimated TRS value.

6.6.5 Test requirements

The average TRS of low, mid and high channel in the data transfers position for GPRS PDTCH/CS1 at 10% BLER shall be lower than test requirements for roaming bands shown in Table 6.6.2. The averaging shall be done in linear scale for the TRS results.

$$TRS_{average} = 10 \log \left[3 / \left(\frac{1}{10^{P_{low}/10}} + \frac{1}{10^{P_{mid}/10}} + \frac{1}{10^{P_{high}/10}} \right) \right]$$

In addition the maximum TRS of each measured channel in the data transfers position shall be better than minimum performance requirements for roaming bands shown in the columns "Max".

$$TRS_{max} = 10 \log \left[\max \left(10^{P_{low}/10}, 10^{P_{mid}/10}, 10^{P_{high}/10} \right) \right]$$

Table 6.6.2: TRS test requirements for GSM LME devices in data transfers position

Operating Band	Unit	<REF _{or} >	
		Average	Max
GSM 850	dBm	TBD	TBD
GSM 900	dBm	TBD	TBD
DCS 1800	dBm	TBD	TBD
PCS 1900	dBm	TBD	TBD
NOTE 1: For Power Class 1 and 4 this shall be achieved at the maximum output power.			
NOTE 2: Applicable for dual-mode GSM/UMTS.			
NOTE 3: Applicable for USB plug-in devices.			

NOTE: If the above Test Requirement differs from the Minimum Requirement then the Test Tolerance applied for this test is non-zero. The Test Tolerance for this test is defined and the explanation of how the Minimum Requirement has been relaxed by the Test Tolerance is given in Annex D.

6.7 Total Radiated Sensitivity (TRS) for TDD UE using LME

Editor's note: This test case is incomplete. The following aspects are either missing or not yet determined:

- *The TRP Minimum Performance Requirement for this test are undefined*
- *The Test Requirements and related Test Tolerances applicable for this test are undefined*

6.7.1 Definition and applicability

The Total Radiated Sensitivity (TRS) is a measure of the minimum power required to achieve a specified Bit Error Rate (BER). The TRS is defined as:

$$TRS = \frac{4\pi}{\oint \left[\frac{1}{EIS_{\theta}(\Omega; f)} + \frac{1}{EIS_{\varphi}(\Omega; f)} \right] d\Omega}$$

Where the effective isotropic sensitivity (*EIS*) is defined as the power available at the antenna output such as the sensitivity threshold is achieved for each polarization. Ω is the solid angle describing the direction, f is frequency. θ and φ are the orthogonal polarizations.

$$TRS \approx \frac{2NM}{\pi \sum_{n=0}^{N-1} \sum_{m=0}^{M-1} \left[\frac{1}{EIS_{\theta}(\theta_n, \varphi_m; f)} + \frac{1}{EIS_{\varphi}(\theta_n, \varphi_m; f)} \right] \sin(\theta_n)}$$

In these formulas N and M are the number of sampling intervals for theta and phi. θ_n and φ_m are the measurement angles. The sampling intervals are discussed further in Section 6.1.2.

The TRS can also be calculated from measurements in a Rayleigh fading 3 dimensional isotropic environment with uniform elevation and azimuth distribution. The calculation of the TRS is in this case based on searching for the lowest power received by the UE/MS for a discrete number of field combinations in the chamber. The power received by the UE at each discrete field combination that provides a BER which is better than the specified target BER level shall be averaged with other such measurements using different field combinations. By calibrating the average power transfer function, an absolute value of the TRS can be obtained when the linear values of all downlink power levels described above have been averaged. The following expression can be used to find the TRS.

$$TRS \approx 2N \frac{\left(\sum_{n=1}^N (C_n (1 - R_n) P_{thres,n}) \right)^{-1}}{\sum_{n=1}^N P_{ref,n}}$$

where $P_{ref,n}$ is the reference power transfer function for fixed measurement antenna n , R_n is the reflection coefficient for fixed measurement antenna n and C_n is the path loss in the cables connecting the measurement receiver to fixed measurement antenna n . These parameters are calculated from the calibration measurement and are further discussed in Annex B.2. $P_{thres,n}$ is calculated by using the following equation:

$$P_{thres,n} = \frac{\sum_{m=1}^M \frac{1}{|S_{21,n,m}^{thres}|^2}}{M}$$

where $S_{21,n,m}^{thres}$ is the m :th value of the transfer function for fixed measurement antenna n , which gives the BER threshold. M is the total number of values of the BER threshold power measured for each fixed measurement antenna.

The requirements and this test apply to all types of UTRA for the TDD UE for Release 11 and later releases that support LME.

NOTE: This test case can be optionally executed for Release 7 and onward UE's supporting LME feature.

6.7.2 Minimum Requirements

The average TRS of low, mid and high channel for 1% BER with 12.2kbps DL reference channel as defined in Annex C.3 of TS 34.122 [13] shall be lower than minimum performance requirements for roaming bands shown in Table 6.7.1. The averaging shall be done in linear scale for the TRS results.

$$TRS_{average} = 10 \log \left[3 / \left(\frac{1}{10^{P_{low}/10}} + \frac{1}{10^{P_{mid}/10}} + \frac{1}{10^{P_{high}/10}} \right) \right]$$

In addition the maximum TRS of each measured channel shall be better than minimum performance requirements for roaming bands shown in the columns "Max".

$$TRS_{max} = 10 \log \left[\max \left(10^{P_{low}/10}, 10^{P_{mid}/10}, 10^{P_{high}/10} \right) \right]$$

Table 6.7.1: TRS minimum requirements for TDD LME devices in data transfer position

Operating Band	Unit	<REFor>	
		Average	Max
-	-		
a	dBm/1.28 MHz	TBD	TBD
b	dBm/1.28 MHz	TBD	TBD
c	dBm/1.28 MHz	TBD	TBD
d	dBm/1.28 MHz	TBD	TBD
e	dBm/1.28 MHz	TBD	TBD
f	dBm/1.28 MHz	TBD	TBD

NOTE 1: Applicable for dual-mode GSM/UTRA LCR TDD.
NOTE 2: Applicable for USB plug-in devices.

The normative reference for this clause is TS25.144 [12] section 7.3.1.3.

6.7.3 Test purpose

The purpose of this test is to ensure that $TRS_{average}$ and TRS_{max} of the UE is above specified limit. The lack of the reception sensitivity decreases the coverage area at the far side from Node B.

6.7.4 Method of test

6.7.4.1 Initial conditions

Test environment: normal; see TS34.122 [13] clause G.2.1.

- 1) Set the SS downlink physical channels according to settings in Table 6.7.2. The DL power level should be set to ensure 0% BER at 12.2kbps data rate at the whole 3D initial scan.
- 2) Connect the plug-in UE to a laptop ground plane phantom. Power on the plug-in UE. The real functional laptop supplies power to the plug-in UE.
- 3) A call is set up according to the Generic call setup procedure. The power control algorithm shall be set to Power Control Algorithm 2.
- 4) Enter the UE into loopback test mode and start the loopback test.

See TS 34.108 [10] and TS 34.109 [11] and Annex C of TS 34.122[13]. For details regarding generic call setup procedure and loopback test.

Table 6.7.2: Downlink Physical Channels transmitted during a connection

Physical Channel	Power
lor	-75 dBm
DwPCH	DwPCH_Ec / lor = 0 dB
PCCPCH	$\sum P\text{-CCPCH_Ec} / \text{lor} = -3$ dB
SCCPCH	$\sum S\text{-CCPCH_Ec} / \text{lor} = -6$ dB
PICH	$\sum \text{PICH_Ec} / \text{lor} = -6$ dB
FPACH	FPACH_Ec / lor = -6 dB
DL DPCH	$\sum \text{DPCH_Ec} / \text{lor} = 0$ dB

6.7.4.2 Procedure

- 1) Send continuously Up power control commands to the plug-in UE.
- 2) As the plug-in UE reaches maximum power, start sending PN15 data pattern.
- 3) Position the plug-in UE into the USB connector in accordance with the manufacturer recommended primary mechanical mode. In the absence of such a recommendation position the plug-in UE so that it is horizontally plugged into the horizontal USB connector.
- 4) Measure EIS from one measurement point. EIS is the power transmitted from one specific direction to the UE causing BER value of $1\% \pm 0.2\%$ using 40000 or more bits, see Annex E.19.3. The DL power step size shall be no bigger than 0.5dB when the RF level is near the TDD UE sensitivity level.

NOTE: To meet BER value target DL power level can be changed using user's freely selectable algorithm.

- 5) Measure the EIS for every direction of selected sampling grid using two orthogonal polarizations to obtain TRS.

- 6) Calculate TRS using equations from clause 6.7.1

NOTE: To speed up sensitivity measurements non standard setting (i.e. data speed, PCL, BER target) can be used in the measurements. However to obtain TRS result the measured EIS figures shall be normalized by

$$\Delta \overline{EIS} = \frac{1}{n} \sum_{i=1}^n (EIS_{std_i} - EIS_{nstd_i})$$

Where $EISstd_i$ is sensitivity measurement done with standard setting. $EISnstd_i$ is sensitivity measurement done with non standard settings. n is amount of reference measurement points.

To ensure accuracy of TRS, the amount of reference points measured should be at least 4. It is recommended to spread the reference measurements equally during the measurement time.

The measurement procedure is based on the measurement of the spherical sensitivity pattern of the DUT. The sensitivity values of the DUT at a predefined BER level are sampled in far field in a group of points located on a spherical surface enclosing the DUT. The EIS samples are taken using a constant sample step of 30° both in theta (θ) and phi (ϕ) directions. All the EIS samples are taken with two orthogonal polarizations, θ - and ϕ -polarisations. The Total Radiated Sensitivity is calculated from the measured data by equation in clause 6.7.1.

6.7.4.3 Test procedure, reverberation chamber method

- 1) Send continuously Up power control commands to the plug-in UE.
- 2) As the plug-in UE reaches maximum power, start sending PN15 data pattern.
- 3) Position the plug-in UE into the USB connector in accordance with the manufacturer recommended primary mechanical mode. In the absence of such a recommendation position the plug-in UE so that it is horizontally plugged into the horizontal USB connector.
- 4) Set the base station simulator to a specific output power and perform a BER measurement.
- 5) Increase or decrease the base station output power as needed, and repeat step 5 until the lowest output power is found that gives a BER value of $1\% \pm 0.2\%$ using 40000 or more bits, see Annex E.19.3. This corresponds to $\left| S_{21,n,m}^{thres} \right|^2$. The DL power step size shall be no bigger than 0.5dB when the RF level is near the TDD UE sensitivity level.

NOTE: To meet BER value target DL power level can be changed using user's freely selectable algorithm.

- 6) Repeat step 4 and 5 until a sufficient number of independent samples (see section 6.1.3) of $\left| S_{21,n,m}^{thres} \right|^2$ has been measured.
- 7) Calculate TRS using equations from clause 6.7.1

NOTE 1: The measurement procedure is based on samples of the received signal power at the UE/MS from a full 3 dimensional isotropic environment with uniform elevation and azimuth field distribution. The power received by the DUT is undergoing Rayleigh fading and is transmitted by the fixed measurement antennas. Moreover, it is important that the samples collected are independent, in order to get sufficient accuracy of the estimated TRS value.

6.7.5 Test requirements

The average TRS of low, mid and high channel for 1% BER with 12.2kbps DL reference channel as defined in Annex C.3 of TS 34.122 [13] shall be lower than test requirements for roaming bands shown in Table 6.7.3. The averaging shall be done in linear scale for the TRS results.

$$TRS_{average} = 10 \log \left[3 / \left(\frac{1}{10^{P_{low}/10}} + \frac{1}{10^{P_{mid}/10}} + \frac{1}{10^{P_{high}/10}} \right) \right]$$

In addition the maximum TRS of each measured channel shall be better than minimum performance requirements for roaming bands shown in the columns "Max".

$$TRS_{max} = 10 \log \left[\max \left(10^{P_{low}/10}, 10^{P_{mid}/10}, 10^{P_{high}/10} \right) \right]$$

Table 6.7.3: TRS test requirements for TDD LME devices in data transfer position

Operating Band	Unit	<REFlor>	
		Average	Max
-	-		
a	dBm/1.28 MHz	TBD + TT	TBD + TT
b	dBm/1.28 MHz	TBD + TT	TBD + TT
c	dBm/1.28 MHz	TBD + TT	TBD + TT
d	dBm/1.28 MHz	TBD + TT	TBD + TT
e	dBm/1.28 MHz	TBD + TT	TBD + TT
f	dBm/1.28 MHz	TBD + TT	TBD + TT

NOTE 1: Applicable for dual-mode GSM/UTRA/LCR TDD.
NOTE 2: Applicable for USB plug-in devices.

NOTE: If the above Test Requirement differs from the Minimum Requirement then the Test Tolerance applied for this test is non-zero. The Test Tolerance for this test is defined and the explanation of how the Minimum Requirement has been relaxed by the Test Tolerance is given in Annex D.

6.8 Total Radiated Sensitivity (TRS) for FDD UE using LEE

Editor's note: This test case is not completed

Minimum Requirements are missing

Test requirements and related TT are missing

6.8.1 Definition and applicability

The Total Radiated Sensitivity is defined as:

$$TRS = \frac{4\pi}{\oint \left[\frac{1}{EIS_{\theta}(\Omega; f)} + \frac{1}{EIS_{\varphi}(\Omega; f)} \right] d\Omega}$$

Where the effective isotropic sensitivity (*EIS*) is defined as the power available at the antenna output such as the sensitivity threshold is achieved for each polarization. Ω is the solid angle describing the direction, f is frequency. θ and φ are the orthogonal polarizations.

$$TRS \approx \frac{2NM}{\pi \sum_{n=0}^{N-1} \sum_{m=0}^{M-1} \left[\frac{1}{EIS_{\theta}(\theta_n, \varphi_m; f)} + \frac{1}{EIS_{\varphi}(\theta_n, \varphi_m; f)} \right] \sin(\theta_n)}$$

In these formulas N and M are the number of sampling intervals for theta and phi. θ_n and φ_m are the measurement angles. The sampling intervals are discussed further in Section 6.1.2.

The TRS can also be calculated from measurements in a Rayleigh fading 3 dimensional isotropic environment with in average uniform elevation and azimuth distribution. The calculation of the TRS is in this case based on searching for the lowest power received by the LEE for a discrete number of field combinations in the chamber that gives a BER that is better than the specified target BER level. By calibrating the average power transfer function, an absolute value of the TRS can be obtained. The following expression can be used to find the TRS.

$$TRS \approx 2N \frac{\left(\sum_{n=1}^N (C_n (1 - R_n) P_{thres,n}) \right)^{-1}}{\sum_{n=1}^N P_{ref,n}}$$

where $P_{ref,n}$ is the reference power transfer function for fixed measurement antenna n, R_n is the reflection coefficient for fixed measurement antenna n and C_n is the path loss in the cables connecting the measurement receiver to fixed measurement antenna n. These parameters are calculated from the calibration measurement and are further discussed in Annex B.2. $P_{thres,n}$ is calculated by using the following equation:

$$P_{thres,n} = \frac{\sum_{m=1}^M \frac{1}{|S_{21,n,m}^{thres}|^2}}{M}$$

where $S_{21,n,m}^{thres}$ is the m:th value of the transfer function for fixed measurement antenna n, which gives the BER threshold. M is the total number of values of the BER threshold power measured for each fixed measurement antenna.

The requirements and this test apply to all types of UTRA for the FDD UE for Release 11 and later releases that support LEE.

NOTE: This test case can be optionally executed for Release 7 and onward UE's supporting LEE feature.

6.8.2 Minimum requirements

The average TRS of low, mid and high channel of the LEE in the data transfers position for 1% BER with 12.2kbps DL reference channel as defined in Annex C.3 of TS25.101 [2] shall be lower than minimum performance requirements for roaming bands shown in Table 68.1. The averaging shall be done in linear scale for the TRS results.

$$TRS_{average} = 10 \log \left[3 / \left(\frac{1}{10^{P_{low}/10}} + \frac{1}{10^{P_{mid}/10}} + \frac{1}{10^{P_{high}/10}} \right) \right]$$

In addition the maximum TRS of each measured channel in the data transfers position shall be better than minimum performance requirements for roaming bands shown in the columns "Max".

$$TRS_{max} = 10 \log \left[\max \left(10^{P_{low}/10}, 10^{P_{mid}/10}, 10^{P_{high}/10} \right) \right]$$

Table 6.8.1: TRS minimum requirements for LEE devices in data transfer position

Operating Band	Unit	<REF _{or} >	
		Average	Max
I	dBm/3.84 MHz	TBD	TBD
II	dBm/3.84 MHz	TBD	TBD
III	dBm/3.84 MHz	TBD	TBD
IV	dBm/3.84 MHz	TBD	TBD
V	dBm/3.84 MHz	TBD	TBD
VI	dBm/3.84 MHz	TBD	TBD
VII	dBm/3.84 MHz	TBD	TBD
VIII	dBm/3.84 MHz	TBD	TBD
IX	dBm/3.84 MHz	TBD	TBD
XIX	dBm/3.84 MHz	TBD	TBD
NOTE 1 For Power Class 3, 3bis and 4 this shall be achieved at the maximum output power.			
NOTE 2 Applicable for dual-mode GSM/UMTS.			
NOTE 3 Applicable for notebook devices.			

The normative reference for this clause is TS25.144 section 7.3.1.1

6.8.3 Test Purpose

The purpose of this test is to ensure that $TRS_{Average}$ and TRS_{max} of the UE is above specified limit. The lack of the reception sensitivity decreases the coverage area at the far side from Node B.

6.8.4 Method of test

6.8.4.1 Initial conditions

Test environment: normal; see TS34.121-1 [3] clause G.2.1.

- 1) Set the SS downlink physical channels according to settings in Table 6.8.2.
- 2) Power on the UE.
- 3) A call is set up according to the Generic call setup procedure. The power control algorithm shall be set to Power Control Algorithm 2. Compressed mode shall be set to OFF.
- 4) Enter the UE into loopback test mode 2 and start the loopback test.

See TS 34.108 [10] and TS 34.109 [11] for details regarding generic call setup procedure and loopback test.

Table 6.8.2: Downlink Physical Channels transmitted during a connection

Physical Channel	Power
CPICH	CPICH_Ec / DPCH_Ec = 7 dB
P-CCPCH	P-CCPCH_Ec / DPCH_Ec = 5 dB
SCH	SCH_Ec / DPCH_Ec = 5 dB
PICH	PICH_Ec / DPCH_Ec = 2 dB
DPCH	Test dependent power

The LEE shall be tested according to DUT positioning described in chapter 6.1.1.

6.8.4.2 Test procedure

- 1) Send continuously Up power control commands to the UE.
- 2) As the UE reaches maximum power, start sending PN15 data pattern.
- 3) Position and configure the LEE according to chapter 6.1.1
- 4) Measure EIS from one measurement point. EIS is the power transmitted from one specific direction to the UE causing BER value of $1\% \pm 0.2\%$ using 20000 or more bits, see Annex E.19.1.

NOTE: To meet BER value target DL power level can be changed using user's freely selectable algorithm.

- 5) Measure the EIS for every direction of selected sampling grid using two orthogonal polarizations to obtain TRS.
- 6) Calculate TRS using equations from chapter 6.8.1

NOTE: To speed up sensitivity measurements non standard setting (i.e. data speed, PCL, BER target) can be used in the measurements. However to obtain TRS result the measured EIS figures shall be normalized by

$$\Delta \overline{EIS} = \frac{1}{n} \sum_{i=1}^n (EIS_{std_i} - EIS_{nstd_i})$$

Where EIS_{std_i} is sensitivity measurement done with standard setting. EIS_{nstd_i} is sensitivity measurement done with non standard settings. n is amount of reference measurement points.

To ensure accuracy of TRS, the amount of reference points measured should be at least 4. It is recommended to spread the reference measurements equally during the measurement time.

The measurement procedure is based on the measurement of the spherical sensitivity pattern of the DUT. The sensitivity values of the DUT at a predefined BER level are sampled in far field in a group of points located on a spherical surface enclosing the DUT. The EIS samples are taken using a constant sample step of 30° both in theta (θ) and phi (ϕ) directions. All the EIS samples are taken with two orthogonal polarizations, θ - and ϕ -polarisations. The Total Radiated Sensitivity is calculated from the measured data by equation in chapter 6.8.1.

6.8.4.3 Test procedure, reverberation chamber method

- 1) Send continuously Up power control commands to the UE.
- 2) As the UE reaches maximum power, start sending PN15 data pattern.
- 3) Position and configure the LEE according to chapter 6.1.14) Set the base station simulator to a specific output power and perform a BER measurement.
- 5) Increase or decrease the base station output power as needed, and repeat step 5 until the lowest output power is found that gives a BER value of $1\% \pm 0.2\%$ using 20000 or more bits, see Annex E.19.1. This corresponds to

$$\left| S_{21,n,m}^{thres} \right|^2.$$

NOTE: To meet BER value target DL power level can be changed using user's freely selectable algorithm.

- 6) Repeat step 4 and 5 until a sufficient number of independent samples (see section 6.1.3) of $\left| S_{21,n,m}^{thres} \right|^2$ has been measured.
- 7) Calculate TRS using equations from chapter 6.8.1

NOTE 1: The measurement procedure is based on samples of the received signal power at the UE/MS from a full 3 dimensional isotropic environment with uniform elevation and azimuth field distribution. The power received by the DUT is undergoing Rayleigh fading and is transmitted by the fixed measurement antennas. Moreover, it is important that the samples collected are independent, in order to get sufficient accuracy of the estimated TRS value.

6.8.5 Test requirements

The average TRS of low, mid and high channel in the data transfers position for 1% BER with 12.2kbps DL reference channel as defined in Annex C.3 of [2] shall be lower than test requirements for roaming bands shown in Table 6.8.3. The averaging shall be done in linear scale for the TRS results.

$$TRS_{average} = 10 \log \left[3 / \left(\frac{1}{10^{P_{low}/10}} + \frac{1}{10^{P_{mid}/10}} + \frac{1}{10^{P_{high}/10}} \right) \right]$$

In addition the maximum TRS of each measured channel in the data transfers position shall be better than minimum performance requirements for roaming bands shown in the columns "Max".

$$TRS_{max} = 10 \log \left[\max \left(10^{P_{low}/10}, 10^{P_{mid}/10}, 10^{P_{high}/10} \right) \right]$$

Table 6.8.3: TRS test requirements for LEE devices in data transfer position

Operating Band	Unit	<REF _{or} >	
		Average	Max
I	dBm/3.84 MHz	TBD	TBD
II	dBm/3.84 MHz	TBD	TBD
III	dBm/3.84 MHz	TBD	TBD
IV	dBm/3.84 MHz	TBD	TBD
V	dBm/3.84 MHz	TBD	TBD
VI	dBm/3.84 MHz	TBD	TBD
VII	dBm/3.84 MHz	TBD	TBD
VIII	dBm/3.84 MHz	TBD	TBD
IX	dBm/3.84 MHz	TBD	TBD
XIX	dBm/3.84 MHz	TBD	TBD

NOTE 1 For Power Class 3, 3bis and 4 this shall be achieved at the maximum output power.
NOTE 2 Applicable for dual-mode GSM/UMTS.
NOTE 3 Applicable for notebook devices.

NOTE: If the above Test Requirement differs from the Minimum Requirement then the Test Tolerance applied for this test is non-zero. The Test Tolerance for this test is defined and the explanation of how the Minimum Requirement has been relaxed by the Test Tolerance is given in Annex D.

6.9 Total Radiated Sensitivity (TRS) for GSM MS using LEE

Editor's note: This test case is not completed

Minimum Requirements are missing

Test requirements and related TT are missing

6.9.1 Definition and applicability

The Total Radiated Sensitivity is defined as:

$$TRS = \frac{4\pi}{\oint \left[\frac{1}{EIS_{\theta}(\Omega; f)} + \frac{1}{EIS_{\varphi}(\Omega; f)} \right] d\Omega}$$

Where the effective isotropic sensitivity (*EIS*) is defined as the power available at the antenna output such as the sensitivity threshold is achieved for each polarization. Ω is the solid angle describing the direction, f is frequency. θ and φ are the orthogonal polarizations.

$$TRS \approx \frac{2NM}{\pi \sum_{n=0}^{N-1} \sum_{m=0}^{M-1} \left[\frac{1}{EIS_{\theta}(\theta_n, \varphi_m; f)} + \frac{1}{EIS_{\varphi}(\theta_n, \varphi_m; f)} \right] \sin(\theta_n)}$$

In these formulas N and M are the number of sampling intervals for theta and phi. θ_n and φ_m are the measurement angles. The sampling intervals are discussed further in Section 6.1.3.

The TRS can also be calculated from measurements in a Rayleigh fading 3 dimensional isotropic environment with uniform elevation and azimuth distribution. The calculation of the TRS is in this case based on searching for the lowest power received by the LEE for a discrete number of field combinations in the chamber. The power received by the UE at each discrete field combination that provides a BLER which is better than the specified target BLER level shall be averaged with other such measurements using different field combinations. By calibrating the average power transfer function, an absolute value of the TRS can be obtained when the linear values of all downlink power levels described above have been averaged. The following expression can be used to find the TRS.

$$TRS \approx 2N \frac{\left(\sum_{n=1}^N (C_n (1 - R_n) P_{thres,n}) \right)^{-1}}{\sum_{n=1}^N P_{ref,n}}$$

where $P_{ref,n}$ is the reference power transfer function for fixed measurement antenna n , R_n is the reflection coefficient for fixed measurement antenna n and C_n is the path loss in the cables connecting the measurement receiver to fixed measurement antenna n . These parameters are calculated from the calibration measurement and are further discussed in Annex B.2. $P_{thres,n}$ is calculated by using the following equation:

$$P_{thres,n} = \frac{\sum_{m=1}^M \frac{1}{|S_{21,n,m}^{thres}|^2}}{M}$$

where $S_{21,n,m}^{thres}$ is the m :th value of the transfer function for fixed measurement antenna n , which gives the BLER threshold. M is the total number of values of the BLER threshold power measured for each fixed measurement antenna.

The requirements and this test apply to all types of LEE that support GSM for Release 11 and later releases.

NOTE: This test case can be optionally executed for Release 7 and onward MS's supporting LEE feature.

6.9.2 Minimum requirements

The average TRS of low, mid and high channel of the LME in the data transfers position for GPRS PDTCH/CS1 at 10% BLER shall be lower than minimum performance requirements for roaming bands shown in Table 6.9.1. The averaging shall be done in linear scale for the TRS results.

$$TRS_{average} = 10 \log \left[3 / \left(\frac{1}{10^{P_{low}/10}} + \frac{1}{10^{P_{mid}/10}} + \frac{1}{10^{P_{high}/10}} \right) \right]$$

In addition the minimum TRS of each measured channel in the data transfers position shall be better than minimum performance requirements for roaming bands shown in the columns "Min".

$$TRS_{max} = 10 \log \left[\max \left(10^{P_{low}/10}, 10^{P_{mid}/10}, 10^{P_{high}/10} \right) \right]$$

Table 6.9.1: TRS minimum requirements for GSM LEE devices in data transfer position

Operating Band	Unit	<REF _{or} >	
		Average	Max
GSM 850	dBm	TBD	TBD
GSM 900	dBm	TBD	TBD
DCS 1800	dBm	TBD	TBD
PCS 1900	dBm	TBD	TBD
NOTE 1: For Power Class 1 and 4 this shall be achieved at the maximum output power.			
NOTE 2: Applicable for dual-mode GSM/UMTS.			
NOTE 3: Applicable for notebook devices.			

The normative reference for this clause is TS25.144 section 7.3.1.2.

6.9.3 Test Purpose

The purpose of this test is to ensure that $TRS_{Average}$ and TRS_{Min} of the MS is above specified limit. The lack of the reception sensitivity decreases the coverage area at the far side from Base Station.

6.9.4 Method of test

6.9.4.1 Initial conditions

Test environment: normal condition; see TS51.010-1 [9] Annex A1.2.2.

A call is set up according to the procedure on GPRS PDTCH/CS1 with an ARFCN in the Mid ARFCN range, power control level set to maximum power.

The SS transmits Standard Test Signal C1 on the traffic channel, see TS51.010-1 [9] Annex A5.2.

The SS commands the MS to create traffic channel loop back, see TS44.014 [34] clause 5.4.

The LEE shall be tested according to DUT positioning described in clause 6.1.1.

6.9.4.2 Test procedure

- 1) Position and configure the LEE according to clause 6.1.1
- 2) The SS compares the data of the signal that it sends to the MS with the signal which is looped back from the receiver after demodulation and decoding.
- 3) The SS determines the number of block error events, by examining sequences of at least the minimum number of samples of consecutive blocks.
- 4) Measure EIS from one measurement point. EIS is the power transmitted from one specific direction to the MS causing BLER value of $10\% \pm 2\%$, see Annex E. 19.2

NOTE: To meet BLER value target DL power level can be changed using user's freely selectable algorithm.

- 5) Measure the EIS for every direction of selected sampling grid using two orthogonal polarizations to obtain TRS.
- 6) Calculate TRS using equations from clause 6.9.1
- 7) Steps 1) to 6) are repeated for GPRS PDTCH/CS1 with ARFCNs in the Low ARFCN range and the High ARFCN range.

NOTE 2: Non standard settings:

To speed up sensitivity measurements non standard setting (i.e. data speed, PCL, BLER target) can be used in the measurements. However to obtain TRS result the measured EIS figures shall be normalized by

$$\Delta \overline{EIS} = \frac{1}{n} \sum_{i=1}^n (EIS_{std_i} - EIS_{nstd_i})$$

Where EIS_{std_i} is sensitivity measurement done with standard setting. EIS_{nstd_i} is sensitivity measurement done with non standard settings. n is amount of reference measurement points.

To ensure accuracy of TRS, the amount of reference points measured should be at least 4. It is recommended to spread the reference measurements equally during the measurement time.

The measurement procedure is based on the measurement of the spherical sensitivity pattern of the DUT. The sensitivity values of the DUT at a predefined BLER level are sampled in far field in a group of points located on a closed surface enclosing the DUT. The EIS samples are taken using a constant sample step of 30° both in theta (θ) and phi (ϕ) directions. All the EIS samples are taken with two orthogonal polarizations, θ - and ϕ -polarisations. The Total Radiated Sensitivity is calculated from the measured data by equation in clause 6.9.1.

6.9.4.3 Test procedure, reverberation chamber method

- 1) Position and configure the LEE according to clause 6.1.1
- 2) The SS compares the data of the signal that it sends to the MS with the signal which is looped back from the receiver after demodulation and decoding.
- 3) The SS determines the number of block error events, by examining sequences of at least the minimum number of samples of consecutive blocks.
- 4) Set the base station simulator to a specific output power and perform a BLER measurement.
- 5) Increase or decrease the base station output power as needed, and repeat step 5 until the lowest output power is found that gives a BLER value of $10\% \pm 2\%$, see Annex E.19.2. This corresponds to $\left| S_{21,n,m}^{thres} \right|^2$.

NOTE: To meet BLER value target DL power level can be changed using user's freely selectable algorithm.

- 6) Repeat step 4 and 5 until a sufficient number of independent samples (see section 6.1.3) of $\left| S_{21,n,m}^{thres} \right|^2$ has been measured.
- 7) Calculate TRS using equations from clause 6.9.1
- 8) Steps 1) to 7) are repeated for GPRS PDTCH/CS1 with ARFCNs in the Low ARFCN range and the High ARFCN range.

NOTE 1: The measurement procedure is based on samples of the received signal power at the UE/MS from a full 3 dimensional isotropic environment with uniform elevation and azimuth field distribution. The power received by the DUT is undergoing Rayleigh fading and is transmitted by the fixed measurement antennas. Moreover, it is important that the samples collected are independent, in order to get sufficient accuracy of the estimated TRS value.

6.9.5 Test requirements

The average TRS of low, mid and high channel in the data transfers position for GPRS PDTCH/CS1 at 10% BLER shall be lower than test requirements for roaming bands shown in Table 6.9.2. The averaging shall be done in linear scale for the TRS results.

$$TRS_{average} = 10 \log \left[3 / \left(\frac{1}{10^{P_{low}/10}} + \frac{1}{10^{P_{mid}/10}} + \frac{1}{10^{P_{high}/10}} \right) \right]$$

In addition the minimum TRS of each measured channel in the data transfers position shall be better than minimum performance requirements for roaming bands shown in the columns "Min".

$$TRS_{max} = 10 \log \left[\max \left(10^{P_{low}/10}, 10^{P_{mid}/10}, 10^{P_{high}/10} \right) \right]$$

Table 6.9.2: TRS test requirements for GSM LEE devices in data transfer position

Operating Band	Unit	<REF _{or} >	
		Average	Max
GSM 850	dBm	TBD	TBD
GSM 900	dBm	TBD	TBD
DCS 1800	dBm	TBD	TBD
PCS 1900	dBm	TBD	TBD
NOTE 1: For Power Class 1 and 4 this shall be achieved at the maximum output power.			
NOTE 2: Applicable for dual-mode GSM/UMTS.			
NOTE 3: Applicable for notebook devices.			

NOTE: If the above Test Requirement differs from the Minimum Requirement then the Test Tolerance applied for this test is non-zero. The Test Tolerance for this test is defined and the explanation of how the Minimum Requirement has been relaxed by the Test Tolerance is given in Annex D.

6.10 Total Radiated Sensitivity (TRS) for TDD UE using LEE

Editor's note: This test case is incomplete. The following aspects are either missing or not yet determined:

- The TRP Minimum Performance Requirement for this test are undefined
- The Test Requirements and related Test Tolerances applicable for this test are undefined

6.10.1 Definition and applicability

The Total Radiated Sensitivity (TRS) is a measure of the minimum power required to achieve a specified Bit Error Rate (BER). The TRS is defined as:

$$TRS = \frac{4\pi}{\oint \left[\frac{1}{EIS_{\theta}(\Omega; f)} + \frac{1}{EIS_{\varphi}(\Omega; f)} \right] d\Omega}$$

Where the effective isotropic sensitivity (*EIS*) is defined as the power available at the antenna output such as the sensitivity threshold is achieved for each polarization. Ω is the solid angle describing the direction, f is frequency. θ and φ are the orthogonal polarizations.

$$TRS \approx \frac{2NM}{\pi \sum_{n=0}^{N-1} \sum_{m=0}^{M-1} \left[\frac{1}{EIS_{\theta}(\theta_n, \varphi_m; f)} + \frac{1}{EIS_{\varphi}(\theta_n, \varphi_m; f)} \right] \sin(\theta_n)}$$

In these formulas N and M are the number of sampling intervals for theta and phi. θ_n and φ_m are the measurement angles. The sampling intervals are discussed further in Section 6.1.2.

The TRS can also be calculated from measurements in a Rayleigh fading 3 dimensional isotropic environment with uniform elevation and azimuth distribution. The calculation of the TRS is in this case based on searching for the lowest power received by the UE/MS for a discrete number of field combinations in the chamber. The power received by the UE at each discrete field combination that provides a BER which is better than the specified target BER level shall be averaged with other such measurements using different field combinations. By calibrating the average power transfer function, an absolute value of the TRS can be obtained when the linear values of all downlink power levels described above have been averaged. The following expression can be used to find the TRS.

$$TRS \approx 2N \frac{\left(\sum_{n=1}^N (C_n (1 - R_n) P_{thres,n}) \right)^{-1}}{\sum_{n=1}^N P_{ref,n}}$$

where $P_{ref,n}$ is the reference power transfer function for fixed measurement antenna n , R_n is the reflection coefficient for fixed measurement antenna n and C_n is the path loss in the cables connecting the measurement receiver to fixed measurement antenna n . These parameters are calculated from the calibration measurement and are further discussed in Annex B.2. $P_{thres,n}$ is calculated by using the following equation:

$$P_{thres,n} = \frac{\sum_{m=1}^M \frac{1}{|S_{21,n,m}^{thres}|^2}}{M}$$

where $S_{21,n,m}^{thres}$ is the m :th value of the transfer function for fixed measurement antenna n , which gives the BER threshold. M is the total number of values of the BER threshold power measured for each fixed measurement antenna.

The requirements and this test apply to all types of UTRA for the TDD UE for Release 11 and later releases that support LEE.

Note: This test case can be optionally executed for Release 7 and onward UE's supporting LEE feature.

6.10.2 Minimum Requirements

The average TRS of low, mid and high channel for 1% BER with 12.2kbps DL reference channel as defined in Annex C.3 of TS 34.122 [13] shall be lower than minimum performance requirements for roaming bands shown in Table 6.10.1. The averaging shall be done in linear scale for the TRS results.

$$TRS_{average} = 10 \log \left[3 / \left(\frac{1}{10^{P_{low}/10}} + \frac{1}{10^{P_{mid}/10}} + \frac{1}{10^{P_{high}/10}} \right) \right]$$

In addition the maximum TRS of each measured channel shall be better than minimum performance requirements for roaming bands shown in the columns "Min".

$$TRS_{max} = 10 \log \left[\max \left(10^{P_{low}/10}, 10^{P_{mid}/10}, 10^{P_{high}/10} \right) \right]$$

Table 6.10.1: TRS minimum requirements for TDD LEE devices in data transfer position

Operating Band	Unit	<REFor>	
		Average	Max
-	-		
a	dBm/1.28 MHz	TBD	TBD
b	dBm/1.28 MHz	TBD	TBD
c	dBm/1.28 MHz	TBD	TBD
d	dBm/1.28 MHz	TBD	TBD
e	dBm/1.28 MHz	TBD	TBD
f	dBm/1.28 MHz	TBD	TBD

NOTE 1: Applicable for dual-mode GSM/UTRA LCR TDD.
NOTE 2: Applicable for notebook devices.

The normative reference for this clause is TS25.144 [12] section 7.3.1.3.

6.10.3 Test purpose

The purpose of this test is to ensure that $TRS_{average}$ and TRS_{max} of the UE is above specified limit. The lack of the reception sensitivity decreases the coverage area at the far side from Node B.

6.10.4 Method of test

6.10.4.1 Initial conditions

Test environment: normal; see TS34.122 [13] clause G.2.1.

- 1) Set the SS downlink physical channels according to settings in Table 6.10.2. The DL power level should be set to ensure 0% BER at 12.2kbps data rate at the whole 3D initial scan.
- 2) Power on the LEE UE.
- 3) A call is set up according to the Generic call setup procedure. The power control algorithm shall be set to Power Control Algorithm 2.
- 4) Enter the UE into loopback test mode and start the loopback test.

See TS 34.108 [10] and TS 34.109 [11] and Annex C of TS 34.122[13]. For details regarding generic call setup procedure and loopback test.

Table 6.10.2: Downlink Physical Channels transmitted during a connection

Physical Channel	Power
lor	-75 dBm
DwPCH	DwPCH_Ec / lor = 0 dB
PCCPCH	$\sum P\text{-CCPCH_Ec} / \text{lor} = -3 \text{ dB}$
SCCPCH	$\sum S\text{-CCPCH_Ec} / \text{lor} = -6 \text{ dB}$
PICH	$\sum \text{PICH_Ec} / \text{lor} = -6 \text{ dB}$
FPACH	FPACH_Ec / lor = -6 dB
DL DPCH	$\sum \text{DPCH_Ec} / \text{lor} = 0 \text{ dB}$

6.10.4.2 Procedure

- 1) Send continuously Up power control commands to the LEE UE.
- 2) As the UE reaches maximum power, start sending PN15 data pattern.
- 3) Position and configure the LEE according to clause 5.1.1
- 4) Measure EIS from one measurement point. EIS is the power transmitted from one specific direction to the UE causing BER value of $1\% \pm 0.2\%$ using 40000 or more bits, see Annex E.19.3. The DL power step size shall be no bigger than 0.5dB when the RF level is near the TDD UE sensitivity level.

NOTE: To meet BER value target DL power level can be changed using user's freely selectable algorithm.

- 5) Measure the EIS for every direction of selected sampling grid using two orthogonal polarizations to obtain TRS.
- 6) Calculate TRS using equations from clause 6.7.1

NOTE: To speed up sensitivity measurements non standard setting (i.e. data speed, PCL, BER target) can be used in the measurements. However to obtain TRS result the measured EIS figures shall be normalized by

$$\Delta \overline{EIS} = \frac{1}{n} \sum_{i=1}^n (EIS_{std_i} - EIS_{nstd_i})$$

Where EIS_{std_i} is sensitivity measurement done with standard setting. EIS_{nstd_i} is sensitivity measurement done with non standard settings. n is amount of reference measurement points.

To ensure accuracy of TRS, the amount of reference points measured should be at least 4. It is recommended to spread the reference measurements equally during the measurement time.

The measurement procedure is based on the measurement of the spherical sensitivity pattern of the DUT. The sensitivity values of the DUT at a predefined BER level are sampled in far field in a group of points located on a spherical surface enclosing the DUT. The EIS samples are taken using a constant sample step of 30° both in theta (θ) and phi (ϕ) directions. All the EIS samples are taken with two orthogonal polarizations, θ - and ϕ -polarisations. The Total Radiated Sensitivity is calculated from the measured data by equation in clause 6.10.1.

6.10.4.3 Test procedure, reverberation chamber method

- 1) Send continuously Up power control commands to the LEE UE.
- 2) As the UE reaches maximum power, start sending PN15 data pattern.
- 3) Position and configure the LEE according to clause 5.1.1
- 4) Set the base station simulator to a specific output power and perform a BER measurement.
- 5) Increase or decrease the base station output power as needed, and repeat step 5 until the lowest output power is found that gives a BER value of $1\% \pm 0.2\%$ using 40000 or more bits, see Annex E.19.3. This corresponds to

$|S_{21,n,m}^{thres}|^2$. The DL power step size shall be no bigger than 0.5dB when the RF level is near the TDD UE sensitivity level.

NOTE: To meet BER value target DL power level can be changed using user's freely selectable algorithm.

- 6) Repeat step 4 and 5 until a sufficient number of independent samples (see section 6.1.3) of $|S_{21,n,m}^{thres}|^2$ has been measured.
- 7) Calculate TRS using equations from chapter 6.10.1

NOTE 1: The measurement procedure is based on samples of the received signal power at the UE/MS from a full 3 dimensional isotropic environment with uniform elevation and azimuth field distribution. The power received by the DUT is undergoing Rayleigh fading and is transmitted by the fixed measurement antennas. Moreover, it is important that the samples collected are independent, in order to get sufficient accuracy of the estimated TRS value.

6.10.5 Test requirements

The average TRS of low, mid and high channel for 1% BER with 12.2kbps DL reference channel as defined in Annex C.3 of TS 34.122 [13] shall be lower than test requirements for roaming bands shown in Table 6.10.3. The averaging shall be done in linear scale for the TRS results.

$$TRS_{average} = 10 \log \left[3 / \left(\frac{1}{10^{P_{low}/10}} + \frac{1}{10^{P_{mid}/10}} + \frac{1}{10^{P_{high}/10}} \right) \right]$$

In addition the maximum TRS of each measured channel shall be better than minimum performance requirements for roaming bands shown in the columns "Max".

$$TRS_{max} = 10 \log \left[\max \left(10^{P_{low}/10}, 10^{P_{mid}/10}, 10^{P_{high}/10} \right) \right]$$

Table 6.10.3: TRS test requirements for TDD LEE devices in data transfer position

Operating Band	Unit	<REFor>	
		Average	Max
-	-		
a	dBm/1.28 MHz	TBD +TT	TBD +TT
b	dBm/1.28 MHz	TBD +TT	TBD +TT
c	dBm/1.28 MHz	TBD +TT	TBD +TT
d	dBm/1.28 MHz	TBD +TT	TBD +TT
e	dBm/1.28 MHz	TBD +TT	TBD +TT
f	dBm/1.28 MHz	TBD +TT	TBD +TT

NOTE 1: Applicable for dual-mode GSM/UTRA-LCR TDD.
NOTE 2: Applicable for notebook devices.

NOTE: If the above Test Requirement differs from the Minimum Requirement then the Test Tolerance applied for this test is non-zero. The Test Tolerance for this test is defined and the explanation of how the Minimum Requirement has been relaxed by the Test Tolerance is given in Annex D.

Annex A (normative): Test system characterization

The main objective of this section is to define basic parameters of simulated user (phantom) and measurement setup.

A.1 Phantom specifications

A.1.1 Head Phantom

The Specific Anthropomorphic Mannequin (SAM) is used for radiated performance measurements without the shell thickness requirement in non-critical areas of SAM. The dielectric properties of used material shall be maintained within $\pm 25\%$ of target properties listed in table A.1. For other frequencies within the frequency range, linear interpolation method shall be used to obtain target dielectric properties.

Table A.1

Frequency (MHz)	Relative Dielectric Constant (ϵ_r)	Conductivity (σ) (S/m)
450	43,5	0,87
835	41,5	0,90
900	41,5	0,97
1450	40,5	1,20
1800	40,0	1,40
1900	40,0	1,40
1950	40,0	1,40
2000	40,0	1,40
2450	39,2	1,80
3000	38,5	2,40

Example of recipe for tissue simulating liquid is presented in annex F.

A.1.2 Laptop Ground Plane Phantom

A laptop ground plane phantom is used for radiated performance measurements in case of plug-in DUT like USB dongles. The laptop ground plane phantom specified in figure A.A1 is composed of the following parts:

A rectangular plane covered by a conductive film on the upper side with thickness of 4 mm to emulate the keyboard and main body of the laptop;

A rectangular plane covered by the same conductive film on the upper side with thickness of 4mm to emulate the screen of the laptop;

The conductive film on the two planes is connected. The angle between the two planes is 110 degrees. The material is FR-4 copper-clad sheet and the length and width of these two planes are 345 mm and 238 mm respectively;

A horizontal USB connector is placed along the short end of the plane. The location of the port is at the right back corner, the distance between the central axis of the USB connector and the rear edge of plane is 45 mm, and the ground of the USB connector is welded on the conductive film of the plane. The detailed description of the structure is specified in figure A.A2;

A USB cable crossing the ground plane and connecting the USB connector to a real functional laptop. The USB cable should be equipped with a shielded metal film, and the portion of the cable that is hanged in the air shall be covered with absorbing material or treated with quarter wave chokes. The part of the USB cable lying on the plane is covered by a conductive adhesive strip used for fixing the cable on the plane and for guarantying at the same time the superficial continuity of the conductive plane. The shielded conductive film of this part of the USB cable is connected to the conductive film of the plane and the covered strip to well ground the antenna. The length of the USB cable should be no more than 3m.

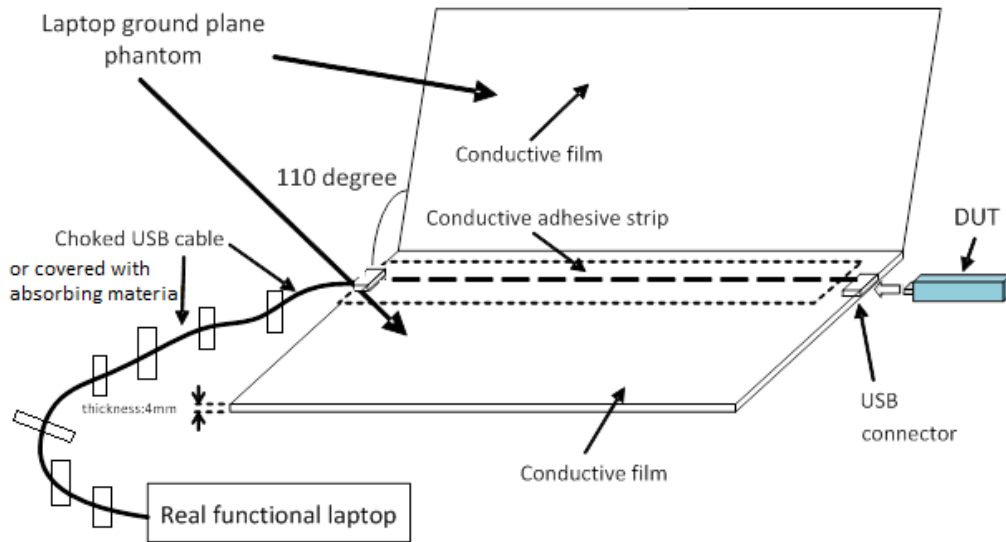

Figure A.A1: The laptop ground plane phantom with DUT and the real functional laptop

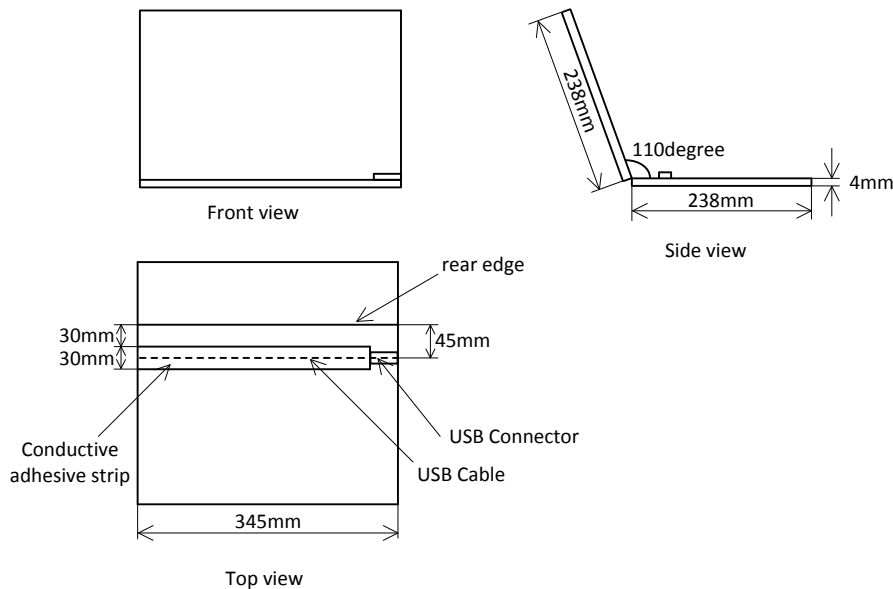

Figure A.A2: The structure and dimension of the laptop ground phantom

A.2 Anechoic chamber constraints

Testing shall be performed in an anechoic chamber fulfilling following requirements.

A.2.1 Positioner

For the DUT positioning on head phantom the chamber should be equipped with a positioner making possible to perform full 3-D measurements for both Tx and Rx radiated performance. The centre of the rotation should be the phase centre of the antenna, in the case it is not possible to evaluate an estimation of the antenna centre should be used. Alternatively centre of the line between right and left ear reference points can be used as a centre of rotation. Theta (θ) and phi (ϕ) angles are specified in figure A.1.

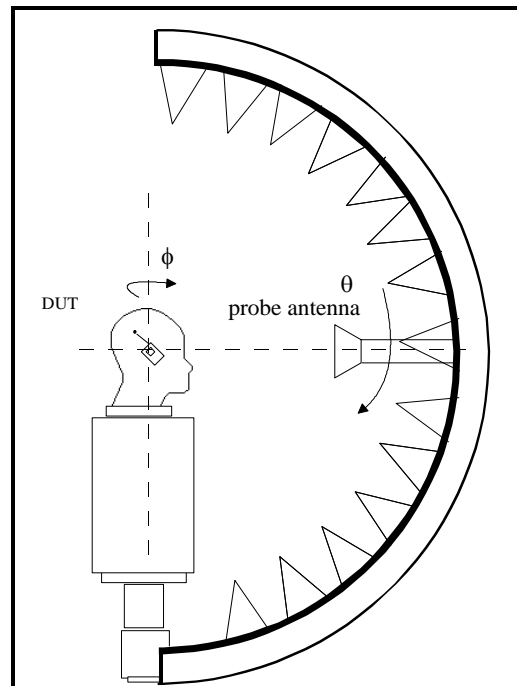

Figure A.1: The coordinate system used in the measurements for the head phantom

For the DUT positioning on laptop ground plane phantom the chamber should be equipped with a positioner making possible to perform full 3-D measurements for both Tx and Rx radiated performance. The real functional laptop is laid on the floor of the anechoic chamber, supplies power to the DUT and controls the state of the DUT. Both the USB cable and the real functional laptop are properly setup in order to have a negligible impact on the measurements: the real functional laptop is fully wrapped up with anechoic absorbers. Theta (θ) and phi (ϕ) angles are specified in figure A.1A.

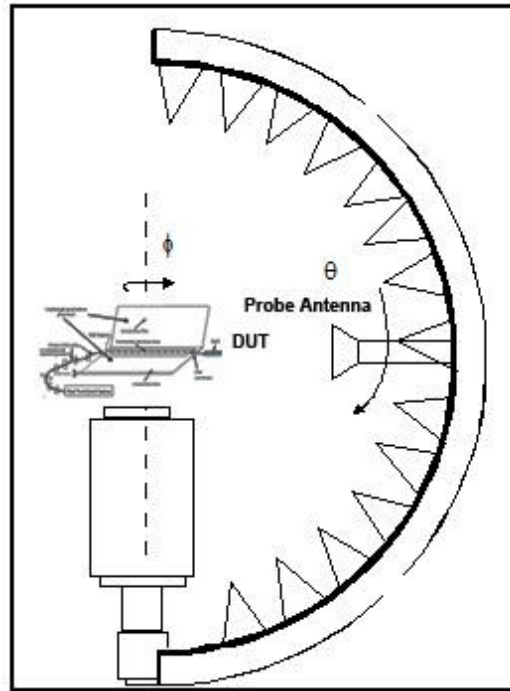

Figure A.1A: The coordinate system used in the measurements for the laptop ground plane phantom

A.2.2 Measurement Antenna

The measurement antenna should be able to measure two orthogonal polarizations (typically linear theta (θ) and phi (ϕ) polarizations). Note that single-polarized linear measurement antenna can also be used by turning it 90° for every measurement point.

For far-field measurements, the distance r between the DUT and the measurement antenna should be

$$r > \max\left(\frac{2D^2}{\lambda}, 3D, 3\lambda\right)$$

where λ is the wavelength of the measurement frequency and D the maximum extension of the radiating structure. Then the phase- and amplitude uncertainty limits and the reactive near field limit are not exceeded. The influence of measurement distance is discussed in Appendix A - Estimation of Measurement Uncertainty

A.2.3 Quiet Zone

Reflectivity of the quiet zone shall be measured for frequencies used with method described in Appendix F. Measured reflectivity level is used in uncertainty calculations.

A.2.4 Shielding effectiveness of the chamber

The recommended level of the shielding effectiveness is -100 dB from 800 MHz to 4 GHz. See Appendix G for more details on shielding effectiveness validation.

A.3 Reverberation chamber constraints

The alternative test method can be realized in a reverberation chamber fulfilling the following requirements.

A.3.1 Positioning and mode stirring facilities

The reverberation chamber shall be equipped with mode-stirring facilities in such a way that enough number of independent power samples can be achieved for the accuracy requirement stated in this standard to be fulfilled. Possible mode-stirring methods include platform stirring, polarization stirring and mechanical stirring with fan-type stirrers, irregular shaped rotational stirrers, or plate-type stirrers. Also frequency stirring is possible if the type of measurement allows for a frequency-averaged value, but this is not necessary if the chamber is sufficiently large and well stirred.

For the DUT positioning on head phantom or for the DUT positioning on laptop ground plane phantom, the DUT should be placed in such a way that a sufficient number of independent samples are obtained to fulfil the uncertainty requirements. For example, for chambers utilizing platform stirring the DUT should be placed on the edge of the turntable in order to maximize rotation of the DUT. In addition, the DUT must not be closer than 0.5 wavelengths to other electromagnetic reflective objects inside the chamber and 0.7 wavelengths to absorbing objects.

For the DUT positioning on laptop ground plane phantom the real functional laptop is laid on the floor of the chamber, supplies power to the DUT and controls the state of the DUT. Both the USB cable and the real functional laptop are properly setup in order to have a negligible impact on the measurements: the real functional laptop is fully wrapped up with anechoic absorbers. The real functional laptop can be placed outside the chamber if the connection to the DUT can be maintained and if the communication interface between DUT and real functional laptop has negligible impact on the measurements.

A schematic picture of the measurement setup is provided in Figure A.2.

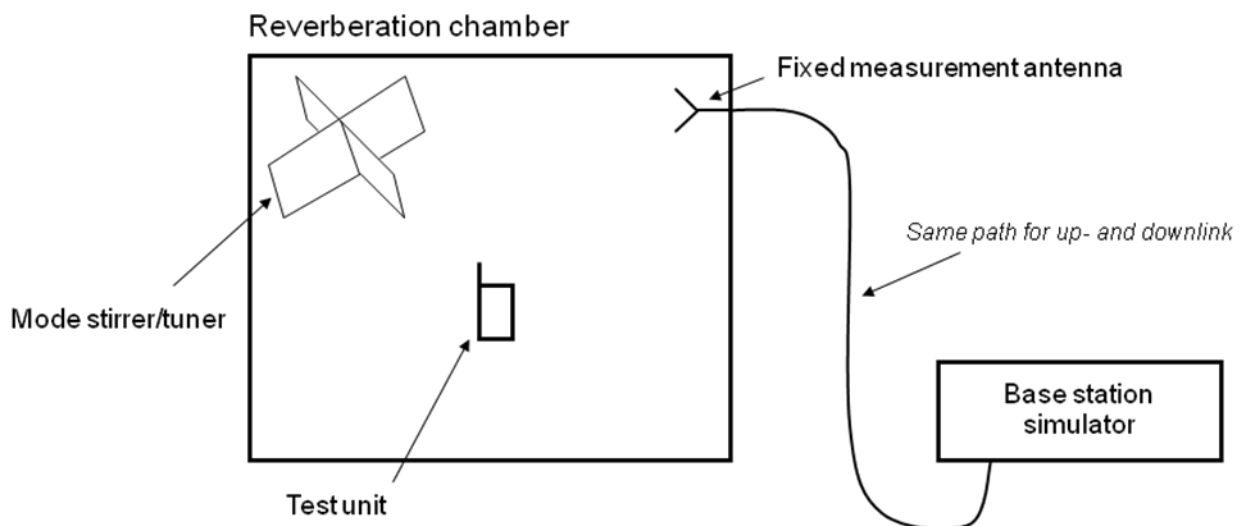

Figure A.2: A schematic picture of the reverberation chamber measurement setup.

A.3.2 Measurement Antennas

It is important that the measurement antennas are configured in such a way that the statistical distribution of waves in the chamber in average corresponds to an isotropic environment.

A.3.3 Chamber size and characteristics

The reverberation chamber shall have a volume large enough to support the number of modes needed for the stated accuracy at the lowest operating frequency. If the UE/MS is moved around in the chamber during the measurement, the volume of the reverberation chamber can be reduced. Also, frequency stirring can be used to improve the accuracy, however, this will reduce the resolution of the results correspondingly.

The reverberation chamber can be loaded with lossy objects in order to control the power delay profile in the chamber to some extent. However the reverberation chamber should not be loaded to such an extent that the mode statistics in the chamber are destroyed. It is important to keep the same amount of lossy objects in the chamber during calibration

measurement and test measurement, in order not to change the average power transfer function between these two cases. Examples of lossy object are head and hand phantoms.

Furthermore, the DUT must not be closer than 0.5 wavelengths to other electromagnetic reflective objects inside the chamber and 0.7 wavelengths to absorbing objects.

A.3.4 Shielding effectiveness of the chamber

The recommended level of the shielding effectiveness is -100 dB from 800 MHz to 4 GHz. See Appendix G.A for more details on shielding effectiveness validation.

A.4 Embedded Devices

The main objectives of this section are to define basic parameters required when performing TRP and TRS measurements on Notebook and Tablets.

A.4.1 Notebook

A notebook PC is a portable personal computer combining the computer, keyboard and display in one form factor. Typically the keyboard is built into the base and the display is hinged along the back edge of the base. The largest single dimension for a notebook is limited to 0.42 m.

As notebooks are not body worn equipment nor recommended for use placed directly on the lap, the notebook shall be tested in a free space configuration without head and hand phantoms.

When the notebook is placed in a measurement chamber the display shall be configured according to Table A.2.

Table A.2: Display settings

Parameter	Value	Note
Display lid angle	110 +/- 5 degrees	The lid angle is defined as the angle between the front of the display to the levelled base.
LCD Backlight	50%	
Ambient sensor	Disabled	

A typical notebook PC is equipped with several radio access technologies. During the measurement the DUT shall be configured according to Table A.3.

Table A.3: Embedded radio transmitters

Parameter	Value	Note
WWAN	Enabled	This is the DUT transceiver
Other transceivers	Disabled	UWB, WLAN, Bluetooth™

The notebook power management shall be configured according to Table A.4.

Table A.4: Power management

Parameter	Value	Note
Screensaver	Disabled	
Turn OFF display	Never	
Turn OFF Hard drive	Never	
System Hibernate	Never	
System Standby	Never	
Dynamic control of clock frequencies	Disabled	
Power source	Standard battery	

If the notebook is equipped with retractable antennas the device shall be tested with the antennas in a configuration recommended by the manufactures.

A.4.2 Tablet

<for future use>

Annex B (normative): Calibration

The relative power values of the measurement points will be transformed to absolute radiated power values (in dBm) by performing a calibration measurement. The calibration measurement is done by using a reference antenna with known efficiency or gain values. In the calibration measurement the reference antenna is measured in the same place as the DUT, and the attenuation of the complete transmission path (L_{total}) from the DUT to the measurement receiver/NB/BS simulator is calibrated out. For the reverberation chamber method, the calibration antenna can be placed in an arbitrarily position in the chamber, as long as it is placed 0.5 wavelengths from other metallic objects and 0.7 wavelengths from absorbing objects.

The gain and/or radiation efficiency of the reference antenna shall be known at the frequency bands in which the calibrations are performed. Recommended calibration antennas are monopole antennas or sleeve dipoles tuned for the each frequency band of interest. Alternatively, other methods may be used if they ensure an equal or greater level of accuracy. A network analyzer is recommended to be used to perform the calibration measurement. Also other devices can be used to measure attenuation. The calibration is performed individually for the both orthogonal polarizations, all the transmission paths and all frequencies used in the testing. For the reverberation chamber method, all polarizations and transmission paths are included in one calibration measurement.

The principle is based on the use of calibration/substitution antennas presenting an efficiency known with a sufficient accuracy in the measurement bandwidths. Such a calibration antenna is placed on the DUT positioner at the exact MS location used for TRP and TRS measurement. It is possible to use a mechanical piece to place the calibration antenna on the positioner. This mechanical piece should not present any electromagnetic properties, which could influence the frequency response and the radiation properties of the calibration antenna. Find hereafter, an illustration of the substitution configuration in Figure B.1.

For the reverberation chamber method the calibration antenna can be place in an arbitrarily position, as long as it is placed 0.5 wavelengths from other metallic objects and 0.7 wavelengths from absorbing objects. An illustration of the measurement setup for this procedure can be found in Figure B.2.

B.1 Calibration Procedure

L_{total} is the attenuation between P and B, see figure B.1.

$$L_{total} = (L_{AB} - L_{AC} + E_{cal})$$

Where L_{AC} is cable loss from A to C. The cable AC connecting the substitution antenna should be such that its influence upon radiation pattern measurements is minimal. L_{AB} is the attenuation between points A and B. In TRP and TRS measurements point B is connected to the calibrated input/output port of measurement receiver.

E_{cal} is the efficiency or gain of the calibration antenna at the frequency of interest.

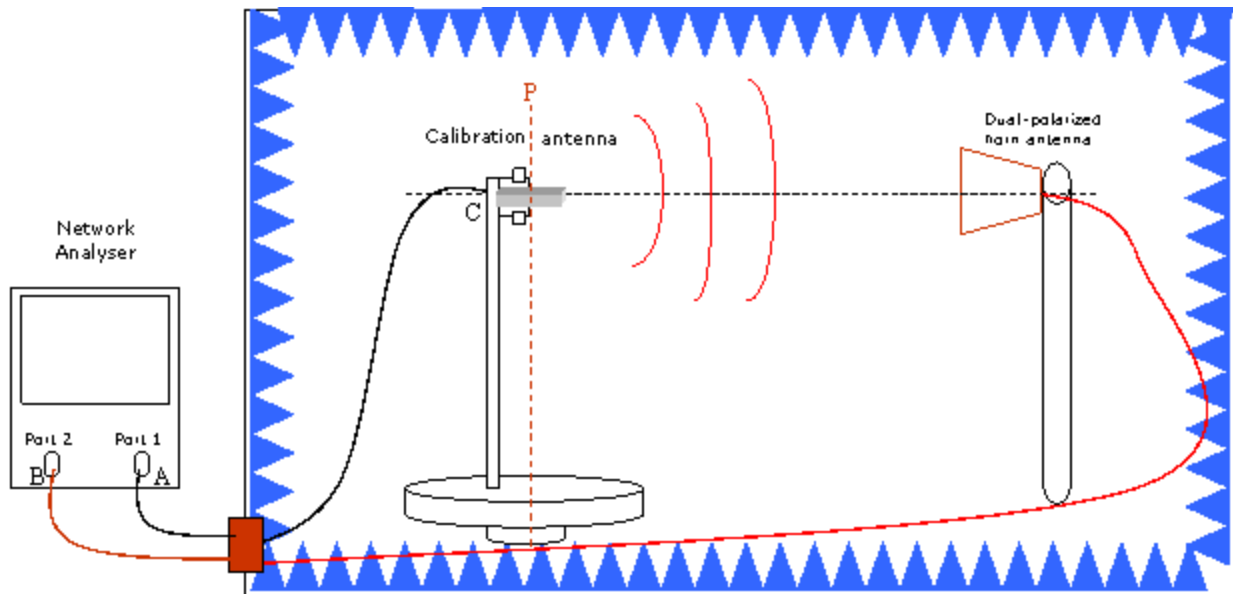

Figure B.1 Calibration/substitution procedures using a vector network analyzer.

If the calibration is based on known efficiency of the calibration antenna, a full spherical scanning is performed to determine L_{AB} . Unless otherwise specified in the calibration antenna documentation, TRP sampling grid and equation for TRP in section 5.2.1 should be used for head phantom and TRP sampling grid and equation for TRP in section 5.5.1 should be used for laptop ground plane phantom and embedded devices.

This procedure has to be done at each frequency of interest.

To achieve measurements with an uncertainty as low as possible, it is absolutely necessary to exactly keep the same P to B configuration (cables, dual-polarized antenna).

B.2 Calibration Procedure – Reverberation Chamber Method

The purpose of the calibration measurement is to determine the average power transfer function in the chamber, mismatch of fixed measurement antennas and path losses in cables connecting the power sampling instrument and the fixed measurement antennas. Preferably a network analyzer is used for these measurements. Recommended calibration antennas are dipoles tuned to the frequency band of interest.

In general, the calibration of a reverberation chamber is performed in three steps:

1. Measurement of S-parameters through the reverberation chamber for a complete stirring sequence
2. Calculation of the chamber reference transfer function
3. Measurement of connecting cable insertion loss

If several setups are used (e.g. empty chamber, chamber with head phantom, etc.), steps 1 and 2 must be repeated for each configuration. The calibration measurement setup can be studied in Figure B.2.

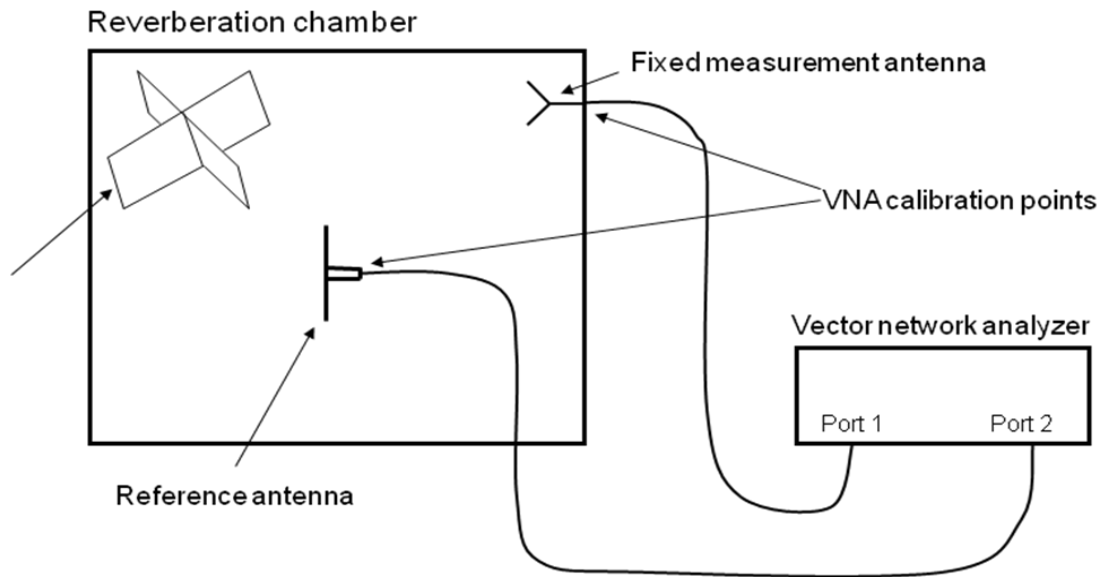

Figure B.2 Calibration measurement setup in the reverberation chamber, using a vector network analyzer.

B.2.1 Measurement of S-parameters through the chamber for a complete stirring sequence

This step will measure S-parameters through the reverberation chamber through a complete stirring sequence. This information is required to determine the chamber's reference transfer function. The procedure must be performed separately for each measurement setup of which the loading of the chamber has been changed. The calibration procedure must be repeated for each frequency as defined above. Therefore, it is advantageous if the network analyzer can be set to a frequency sweep covering the defined frequencies, so that all frequencies of interest can be measured with a minimal number of measurement runs.

- i. Place all objects into the RC which will be used during TRP or TRS measurements, including a head phantom, hand phantom and fixture for the EUT. This ensures that the loss in the chamber, which determines the average power transfer level, is the same during both calibration and test measurements. Also, if the EUT is large or contains many antennas, it may represent a noticeable loading of the chamber. It should then be present in the chamber and turned on during the calibration.
- ii. Place the calibration antenna inside the chamber. The calibration antenna is preferably mounted on a low-loss dielectric fixture, to avoid effects from the fixture itself which may affect the EUT's radiation efficiency and mismatch factor. The calibration antenna must be placed in the chamber in such a way that it is far enough from any walls, mode-stirrers, head phantom, or other object, such that the environment for the calibration antenna (taken over the complete stirring sequence) resembles a free space environment. "Far enough away" depends on the type of calibration antenna used. For low gain nearly omnidirectional antennas like dipoles, it is normally sufficient to ensure that this spacing is larger than 0.5 wavelengths. More directive calibration antennas should be situated towards the centre of the chamber. The calibration antenna should be present in the chamber during the TRP/TRS measurements.
- iii. Calibrate the network analyzer with a full 2-port calibration in such a way that the vector S-parameters between the ports of the fixed measurement antenna and the calibration antenna can be accurately measured. Preferably, the network analyzer is set to perform a frequency sweep at each stirrer position. This will enable calibration of several frequency points during the same stirring sequence, thereby reducing calibration time. This will also enable frequency stirring, i.e., averaging the measured power transfer function over a small frequency bandwidth around each measured frequency point (moving frequency window). This will increase accuracy at the expense of frequency resolution.
- iv. Connect the antennas and measure the S-parameters for each stirrer position and each fixed measurement antenna.

The number of stirrer positions in the chosen stirring sequence, i.e. the number of S-parameter samples at each frequency point, should be chosen in such a way that it is large enough to yield an acceptable statistical contribution to the total measurement uncertainty. As a guideline it should be larger than 100, preferable 200 or 400 to ensure that the number of independent samples is not severely limited by the total number of samples measured. The number of independent samples, which is a subset of all samples, determines the statistical contribution to the expanded accuracy (which is two times the standard deviation). This should be not less than 100 to ensure an expanded accuracy better than 0.5 dB. The number of independent samples depends on the operating frequency, volume of the chamber, efficacy of the chamber's stirrers, the level of loading by absorbing objects, and whether or not frequency stirring is used.

The sequence of moving the stirrers to different positions may be either step-wise (stopping stirrer for each sample) or continuous (sampling on-the-fly). With continuous stirring it may not be possible to characterize the chamber over a wide frequency band at the same time.

B.2.2 Calculation of the chamber reference transfer function

From the S-parameters obtained in the calibration measurement, the chamber reference transfer function for fixed antenna n can be calculated. The reflection coefficient for fixed antenna n can be calculated as

$$R_n = \left| \frac{1}{M} \sum_{m=1}^M S_{11,n,m} \right|^2 = \left| \overline{S_{11,n}} \right|^2$$

Thus, the chamber reference transfer function can be calculated as

$$P_{ref,n} = \frac{1}{M} \sum_{m=1}^M \frac{|S_{21,n,m}|^2}{(1 - R_n)(1 - |\overline{S_{22}}|^2)} \cdot \frac{1}{e_{ref}}$$

where M is the total number of samples of the transfer function measured for each fixed measurement antenna and $S_{21,n,m}$ is sample number m of the transfer function for measurement antenna n . Moreover, $\overline{S_{22}}$ is the complex average of the calibration antenna reflection coefficient. Finally, e_{ref} is the radiation efficiency of the calibration antenna.

Note that the radiation efficiency of the fixed antenna is not corrected for, because it will be the same both during calibration and measurements. Therefore the fixed antenna's radiation efficiency will not affect the final results. The same can be said about the mismatch factor of the fixed measurement antennas, but it is still advantageous to correct for this factor if frequency stirring is applied to improve accuracy.

B.2.2 Calculation of the chamber reference transfer function

From the S-parameters obtained in the calibration measurement, the chamber reference transfer function for fixed antenna n can be calculated. The reflection coefficient for fixed antenna n can be calculated as

$$R_n = \left| \frac{1}{M} \sum_{m=1}^M S_{11,n,m} \right|^2 = \left| \overline{S_{11,n}} \right|^2$$

Thus, the chamber reference transfer function can be calculated as

$$P_{ref,n} = \frac{1}{M} \sum_{m=1}^M \frac{|S_{21,n,m}|^2}{(1 - R_n)(1 - |\overline{S_{22}}|^2)} \cdot \frac{1}{e_{ref}}$$

where M is the total number of samples of the transfer function measured for each fixed measurement antenna and $S_{21,n,m}$ is sample number m of the transfer function for measurement antenna n . Moreover, $\overline{S_{22}}$ is the complex

average of the calibration antenna reflection coefficient. Finally, e_{ref} is the radiation efficiency of the calibration antenna.

Note that the radiation efficiency of the fixed antenna is not corrected for, because it will be the same both during calibration and measurements. Therefore the fixed antenna's radiation efficiency will not affect the final results. The same can be said about the mismatch factor of the fixed measurement antennas, but it is still advantageous to correct for this factor if frequency stirring is applied to improve accuracy.

B.2.3 Cable calibration

This measurement step will calibrate the power loss of the cable needed to connect the instrument used to measure the received power at the fixed measurement antenna during TRP measurements, and to generate the power radiated by the fixed antenna during TRS measurements.

- i. Disconnect the cables between the VNA and the chamber.
- ii. Connect the cables one-by-one between the two ports of the network analyzer. The VNA must be calibrated at its own two ports.
- iii. Measure the frequency response of the transmission S-parameter (S_{21} or S_{12}) of the cable.
- iv. Save the power transfer values ($|S_{21}|^2$) of the frequency response curve for the test frequencies, and cables positions, etc).

Calibration shall be performed yearly or if any equipment in the measurement system is changed.

Annex C (normative): Measurement Test Report

Operational mode, model and serial number of the DUT shall be documented to the test report. Whether the DUT is positioned against the phantom head with a specific device holder or by other means it should be described in the test report. When the DUT is positioned on the laptop ground plane phantom it should be described in the test report. A photograph of the test setup is recommended.

Test equipment list should be included in the test report.

\overline{TRP} [dBm] and \overline{TRS} [dBm] values shall be reported for each tested channel and for each side of the head and a frequency band average shall be calculated by using following equations when the phantom head is used.

$$\overline{TRP} = 10 \log \left[\frac{10^{\frac{TRP_{low_right}}{10}} + 10^{\frac{TRP_{mid_right}}{10}} + 10^{\frac{TRP_{high_right}}{10}} + 10^{\frac{TRP_{low_left}}{10}} + 10^{\frac{TRP_{mid_left}}{10}} + 10^{\frac{TRP_{high_left}}{10}}}{6}} \right]$$

$$\overline{TRS} = 10 \log \left[\frac{6}{10^{\frac{-TRS_{low_right}}{10}} + 10^{\frac{-TRS_{mid_right}}{10}} + 10^{\frac{-TRS_{high_right}}{10}} + 10^{\frac{-TRS_{low_left}}{10}} + 10^{\frac{-TRS_{mid_left}}{10}} + 10^{\frac{-TRS_{high_left}}{10}}} \right]$$

\overline{TRP} [dBm] and \overline{TRS} [dBm] values shall be reported for each tested channel and a frequency band average shall be calculated by using following equations when the laptop ground plane phantom is used and when the embedded devices are tested.

$$\overline{TRP} = 10 \log \left[\frac{10^{\frac{TRP_{low}/10}} + 10^{\frac{TRP_{mid}/10}} + 10^{\frac{TRP_{high}/10}}}{3}} \right]$$

$$\overline{TRS} = 10 \log \left[3 / \left(\frac{1}{10^{\frac{TRS_{low}/10}} + \frac{1}{10^{\frac{TRS_{mid}/10}} + \frac{1}{10^{\frac{TRS_{high}/10}}}} \right) \right]$$

The expanded measurement uncertainty, assessed according Annex E, shall be documented next to the corresponding TRP and TRS results. The uncertainty calculation shall be made available.

Annex D (normative): Maximum uncertainty of Test System and Test Tolerances

D.1 Maximum uncertainty of Test System

The maximum acceptable uncertainty of the Test System is specified below for each test. The Test System shall enable test to be measured with an uncertainty not exceeding the specified values. All uncertainties are absolute values and are valid for a confidence level of 95 %.

The estimation of measurement uncertainty is presented in more detail in Annex E.

Table D.1: Test system uncertainties for OTA tests

Clause	Maximum Test System Uncertainty	Derivation of Test System Uncertainty
5.2 TRP for FDD UE	Bands I,II,III,IV,V,VI,VII,VIII,IX ±1.9 dB for single measurement	Detailed derivations of uncertainty can be found in Annex E
5.3 TRP for GSM MS	Bands GSM 850, P-GSM 900, E-GSM 900, DCS 1800, PCS 1900 ±1.9 dB for single measurement	Detailed derivations of uncertainty can be found in Annex E
5.4 TRP for TDD UE	Bands a,e,f ±1.9 dB for single measurement	Detailed derivations of uncertainty can be found in Annex E
5.5 TRP for FDD UE using LME	Bands I,II,III,IV,V,VI,VII,VIII,IX ±1.9 dB for single measurement	Detailed derivations of uncertainty can be found in Annex E
5.6 TRP for GSM UE using LME	Bands GSM 850, GSM 900, DCS 1800, PCS 1900 ±1.9 dB for single measurement	Detailed derivations of uncertainty can be found in Annex E
5.7 TRP for TDD UE using LME	Bands a,e,f ±1.9 dB for single measurement	Detailed derivations of uncertainty can be found in Annex E
5.8 TRP for FDD using LEE	Bands I,II,III,IV,V,VI,VII,VIII,IX ±1.9 dB for single measurement	Detailed derivations of uncertainty can be found in Annex E
5.9 TRP for GSM using LEE	Bands GSM 850, GSM 900, DCS 1800, PCS 1900 ±1.9 dB for single measurement	Detailed derivations of uncertainty can be found in Annex E
5.10 TRP for TDD using LEE	Bands a,e,f ±1.9 dB for single measurement	Detailed derivations of uncertainty can be found in Annex E
6.2 TRS for FDD UE	Bands I,II,III,IV,V,VI,VII,VIII,IX ±2.3 dB for single measurement	Detailed derivations of uncertainty can be found in Annex E.
6.3 TRS for GSM MS	Bands GSM 850, P-GSM 900, E-GSM 900, DCS 1800, PCS 1900 ±2.3 dB for single measurement	Detailed derivations of uncertainty can be found in Annex E
6.4 TRS for TDD UE	Bands a,e,f ±2.3 dB for single measurement	Detailed derivations of uncertainty can be found in Annex E
6.5 TRS for FDD UE using LME	Bands I,II,III,IV,V,VI,VII,VIII,IX ±2.3 dB for single measurement	Detailed derivations of uncertainty can be found in Annex E
6.6 TRS for GSM UE using LME	Bands GSM 850, GSM 900, DCS 1800, PCS 1900 ±2.3 dB for single measurement	Detailed derivations of uncertainty can be found in Annex E
6.7 TRS for TDD UE using LME	Bands a,e,f ±2.3 dB for single measurement	Detailed derivations of uncertainty can be found in Annex E
6.8 TRS for FDD using LEE	Bands I,II,III,IV,V,VI,VII,VIII,IX ±2.3 dB for single measurement	Detailed derivations of uncertainty can be found in Annex E
6.9 TRS for GSM using LEE	Bands GSM 850, GSM 900, DCS 1800, PCS 1900 ±2.3 dB for single measurement	Detailed derivations of uncertainty can be found in Annex E
6.10 TRS for TDD using LEE	Bands a,e,f ±2.3 dB for single measurement	Detailed derivations of uncertainty can be found in Annex E

D.2 Test tolerances (informative)

Test tolerances below are used to relax the Minimum Requirements in the present document to derive the Test Requirements.

Table D.2: Test tolerances for OTA tests

Clause	Test Tolerance
5.2 TRP for FDD UE	Bands I,II,III,IV,V,VI,VII,VIII,IX 1.0 dB for minimum requirement 0.7 dB for average requirement
5.3 TRP for GSM MS	Bands GSM 850, P-GSM 900, E-GSM 900, DCS 1800, PCS 1900 1.0 dB for minimum requirement 0.7 dB for average requirement
5.4 TRP for TDD UE	Bands a,e,f 1.0 dB for minimum requirement 0.7 dB for average requirement
5.5 TRP for FDD UE using LME	Bands I,II,III,IV,V,VI,VII,VIII,IX 1.0 dB for minimum requirement 0.7 dB for average requirement
5.6 TRP for GSM UE using LME	Bands GSM 850, GSM 900, DCS 1800, PCS 1900 1.0 dB for minimum requirement 0.7 dB for average requirement
5.7 TRP for TDD UE using LME	Bands a,e,f 1.0 dB for minimum requirement 0.7 dB for average requirement
5.8 TRP for FDD using LEE	Bands I,II,III,IV,V,VI,VII,VIII,IX 1.0 dB for minimum requirement 0.7 dB for average requirement
5.9 TRP for GSM using LEE	Bands GSM 850, GSM 900, DCS 1800, PCS 1900 1.0 dB for minimum requirement 0.7 dB for average requirement
5.10 TRP for TDD using LEE	Bands a,e,f 1.0 dB for minimum requirement 0.7 dB for average requirement
6.2 TRS for FDD UE	Bands I,II,III,IV,V,VI,VII,VIII,IX 1.2 dB for maximum requirement 0.9 dB for average requirement
6.3 TRS for GSM MS	Bands GSM 850, P-GSM 900, E-GSM 900, DCS 1800, PCS 1900 1.2 dB for maximum requirement 0.9 dB for average requirement
6.2 TRS for TDD UE	Bands a,e,f 1.2 dB for minimum requirement 0.9 dB for average requirement
6.5 TRS for FDD UE using LME	Bands I,II,III,IV,V,VI,VII,VIII,IX 1.2 dB for maximum requirement 0.9 dB for average requirement
6.6 TRS for GSM UE using LME	Bands GSM 850, P-GSM 900, E-GSM 900, DCS 1800, PCS 1900 1.2 dB for maximum requirement 0.9 dB for average requirement
6.7 TRS for TDD UE using LME	Bands a,e,f 1.2 dB for minimum requirement 0.9 dB for average requirement
6.8 TRS for FDD using LEE	Bands I,II,III,IV,V,VI,VII,VIII,IX 1.2 dB for maximum requirement 0.9 dB for average requirement
6.9 TRS for GSM using LEE	Bands GSM 850, GSM 900, DCS 1800, PCS 1900 1.2 dB for maximum requirement 0.9 dB for average requirement
6.10 TRS for TDD using LEE	Bands a,e,f 1.2 dB for maximum requirement 0.9 dB for average requirement

D.3 Derivation of Test Requirements (informative)

Table D.3: Derivation of test requirements for OTA tests

Clause	Operating Band	Minimum requirement in TS25.144		Test Tolerance (TT)		Test requirement in TS34.114	
		Average	Min	Average	Min	Average	Min
		dBm	dBm	dB	dB	dBm	dBm
5.2 TRP for FDD UE (Power Class 3 and 3bis)	I	15	13	0.7	1	14.3	12
	II	15	13	0.7	1	14.3	12
	III	15	13	0.7	1	14.3	12
	IV	15	13	0.7	1	14.3	12
	V	11	9	0.7	1	10.3	8
	VI	11	9	0.7	1	10.3	8
	VII	15	13	0.7	1	14.3	12
	VIII	12	10	0.7	1	11.3	9
	IX	15	13	0.7	1	14.3	12
	XIX	11.5	9.5	0.7	1	10.8	8.5
5.2 TRP for FDD UE (Power Class 4)	I	13	11	0.7	1	12.3	10
	II	13	11	0.7	1	12.3	10
	III	13	11	0.7	1	12.3	10
	IV	13	11	0.7	1	12.3	10
	V	9	7	0.7	1	8.3	6
	VI	9	7	0.7	1	8.3	6
	VII	13	11	0.7	1	12.3	10
	VIII	10	8	0.7	1	9.3	7
	IX	13	11	0.7	1	12.3	10
	XIX	9.5	7.5	0.7	1	8.8	6.5
5.3 TRP for GSM MS	GSM 850	19.5	17.5	0.7	1	18.8	16.5
	P-GSM 900	20.5	18.5	0.7	1	19.8	17.5
	E-GSM 900	20.5	18.5	0.7	1	19.8	17.5
	DCS 1800	21	19	0.7	1	20.3	18
	PCS 1900	21	19	0.7	1	20.3	18
5.4 TRP for TDD UE	a	+15	+13	0.7	1	+14.3	+12
	b	TBD	TBD	TBD	TBD	TBD	TBD
	c	TBD	TBD	TBD	TBD	TBD	TBD
	d	TBD	TBD	TBD	TBD	TBD	TBD
	e	+15	+13	0.7	1	+14.3	+12
	f	+15	+13	0.7	1	+14.3	+12
5.5 TRP for FDD UE using LME (Power Class 3 and 3bis)	I	TBD	TBD	TBD	TBD	TBD	TBD
	II	TBD	TBD	TBD	TBD	TBD	TBD
	III	TBD	TBD	TBD	TBD	TBD	TBD
	IV	TBD	TBD	TBD	TBD	TBD	TBD
	V	TBD	TBD	TBD	TBD	TBD	TBD
	VI	TBD	TBD	TBD	TBD	TBD	TBD
	VII	TBD	TBD	TBD	TBD	TBD	TBD
	VIII	TBD	TBD	TBD	TBD	TBD	TBD
	IX	TBD	TBD	TBD	TBD	TBD	TBD
	XIX	TBD	TBD	TBD	TBD	TBD	TBD
5.5 TRP for FDD UE using LME (Power Class 4)	I	TBD	TBD	TBD	TBD	TBD	TBD
	II	TBD	TBD	TBD	TBD	TBD	TBD
	III	TBD	TBD	TBD	TBD	TBD	TBD
	IV	TBD	TBD	TBD	TBD	TBD	TBD
	V	TBD	TBD	TBD	TBD	TBD	TBD
	VI	TBD	TBD	TBD	TBD	TBD	TBD
	VII	TBD	TBD	TBD	TBD	TBD	TBD
	VIII	TBD	TBD	TBD	TBD	TBD	TBD
	IX	TBD	TBD	TBD	TBD	TBD	TBD
	XIX	TBD	TBD	TBD	TBD	TBD	TBD
5.6 TRP for GSM UE using LME	GSM 850	TBD	TBD	TBD	TBD	TBD	TBD
	GSM 900	TBD	TBD	TBD	TBD	TBD	TBD
	DCS 1800	TBD	TBD	TBD	TBD	TBD	TBD
	PCS 1900	TBD	TBD	TBD	TBD	TBD	TBD

5.7 TRP for TDD UE using LME	a	TBD	TBD	TBD	TBD	TBD	TBD
	b	TBD	TBD	TBD	TBD	TBD	TBD
	c	TBD	TBD	TBD	TBD	TBD	TBD
	d	TBD	TBD	TBD	TBD	TBD	TBD
	e	TBD	TBD	TBD	TBD	TBD	TBD
	f	TBD	TBD	TBD	TBD	TBD	TBD
5.8 TRP for FDD using LEE (Power Class 3 and 3bis)	I	TBD	TBD	TBD	TBD	TBD	TBD
	II	TBD	TBD	TBD	TBD	TBD	TBD
	III	TBD	TBD	TBD	TBD	TBD	TBD
	IV	TBD	TBD	TBD	TBD	TBD	TBD
	V	TBD	TBD	TBD	TBD	TBD	TBD
	VI	TBD	TBD	TBD	TBD	TBD	TBD
	VII	TBD	TBD	TBD	TBD	TBD	TBD
	VIII	TBD	TBD	TBD	TBD	TBD	TBD
	IX	TBD	TBD	TBD	TBD	TBD	TBD
5.8 TRP for FDD using LEE (Power Class 4)	I	TBD	TBD	TBD	TBD	TBD	TBD
	II	TBD	TBD	TBD	TBD	TBD	TBD
	III	TBD	TBD	TBD	TBD	TBD	TBD
	IV	TBD	TBD	TBD	TBD	TBD	TBD
	V	TBD	TBD	TBD	TBD	TBD	TBD
	VI	TBD	TBD	TBD	TBD	TBD	TBD
	VII	TBD	TBD	TBD	TBD	TBD	TBD
	VIII	TBD	TBD	TBD	TBD	TBD	TBD
	IX	TBD	TBD	TBD	TBD	TBD	TBD
5.9 TRP for GSM using LEE	GSM 850	TBD	TBD	TBD	TBD	TBD	TBD
	GSM 900	TBD	TBD	TBD	TBD	TBD	TBD
	DCS 1800	TBD	TBD	TBD	TBD	TBD	TBD
	PCS 1900	TBD	TBD	TBD	TBD	TBD	TBD
5.10 TRP for TDD using LEE	a	TBD	TBD	TBD	TBD	TBD	TBD
	b	TBD	TBD	TBD	TBD	TBD	TBD
	c	TBD	TBD	TBD	TBD	TBD	TBD
	d	TBD	TBD	TBD	TBD	TBD	TBD
	e	TBD	TBD	TBD	TBD	TBD	TBD
	f	TBD	TBD	TBD	TBD	TBD	TBD
6.2 TRS for FDD UE	I	-101	-98	0.9	1.2	-100.1	-96.8
	II	-99	-96	0.9	1.2	-98.1	-94.8
	III	-98	-95	0.9	1.2	-97.1	-93.8
	IV	-101	-98	0.9	1.2	-100.1	-96.8
	V	-96	-93	0.9	1.2	-95.1	-91.8
	VI	-96	-93	0.9	1.2	-95.1	-91.8
	VII	-99	-96	0.9	1.2	-98.1	-94.8
	VIII	-96	-93	0.9	1.2	-95.1	-91.8
	IX	-100	-97	0.9	1.2	-99.1	-95.8
6.3 TRS for GSM MS	GSM 850	-98	-95	0.9	1.2	-97.1	-93.8
	P-GSM 900	-97	-94	0.9	1.2	-96.1	-92.8
	E-GSM 900	-97	-94	0.9	1.2	-96.1	-92.8
	DCS 1800	-99.5	-96.5	0.9	1.2	-98.6	-95.3
	PCS 1900	-98.5	-95.5	0.9	1.2	-97.6	-94.3
6.4 TRS for TDD UE	a	-101	-100	0.9	1.2	-100.1	-98.8
	b	TBD	TBD	TBD	TBD	TBD	TBD
	c	TBD	TBD	TBD	TBD	TBD	TBD
	d	TBD	TBD	TBD	TBD	TBD	TBD
	e	-101	-100	0.9	1.2	-100.1	-98.8
	f	-101	-100	0.9	1.2	-100.1	-98.8
6.5 TRS for FDD UE using LME	I	TBD	TBD	TBD	TBD	TBD	TBD
	II	TBD	TBD	TBD	TBD	TBD	TBD
	III	TBD	TBD	TBD	TBD	TBD	TBD
	IV	TBD	TBD	TBD	TBD	TBD	TBD
	V	TBD	TBD	TBD	TBD	TBD	TBD
	VI	TBD	TBD	TBD	TBD	TBD	TBD
	VII	TBD	TBD	TBD	TBD	TBD	TBD
	VIII	TBD	TBD	TBD	TBD	TBD	TBD

	IX	TBD	TBD	TBD	TBD	TBD	TBD
	XIX	TBD	TBD	TBD	TBD	TBD	TBD
6.6 TRS for GSM UE using LME	GSM 850	TBD	TBD	TBD	TBD	TBD	TBD
	GSM 900	TBD	TBD	TBD	TBD	TBD	TBD
	DCS 1800	TBD	TBD	TBD	TBD	TBD	TBD
	PCS 1900	TBD	TBD	TBD	TBD	TBD	TBD
6.7 TRS for TDD UE using LME	a	TBD	TBD	TBD	TBD	TBD	TBD
	b	TBD	TBD	TBD	TBD	TBD	TBD
	c	TBD	TBD	TBD	TBD	TBD	TBD
	d	TBD	TBD	TBD	TBD	TBD	TBD
	e	TBD	TBD	TBD	TBD	TBD	TBD
	f	TBD	TBD	TBD	TBD	TBD	TBD
6.8 TRS for FDD using LEE	I	TBD	TBD	TBD	TBD	TBD	TBD
	II	TBD	TBD	TBD	TBD	TBD	TBD
	III	TBD	TBD	TBD	TBD	TBD	TBD
	IV	TBD	TBD	TBD	TBD	TBD	TBD
	V	TBD	TBD	TBD	TBD	TBD	TBD
	VI	TBD	TBD	TBD	TBD	TBD	TBD
	VII	TBD	TBD	TBD	TBD	TBD	TBD
	VIII	TBD	TBD	TBD	TBD	TBD	TBD
	IX	TBD	TBD	TBD	TBD	TBD	TBD
	XIX	TBD	TBD	TBD	TBD	TBD	TBD
6.9 TRS for GSM using LEE	GSM 850	TBD	TBD	TBD	TBD	TBD	TBD
	GSM 900	TBD	TBD	TBD	TBD	TBD	TBD
	DCS 1800	TBD	TBD	TBD	TBD	TBD	TBD
	PCS 1900	TBD	TBD	TBD	TBD	TBD	TBD
6.10 TRS for TDD using LEE	a	TBD	TBD	TBD	TBD	TBD	TBD
	b	TBD	TBD	TBD	TBD	TBD	TBD
	c	TBD	TBD	TBD	TBD	TBD	TBD
	d	TBD	TBD	TBD	TBD	TBD	TBD
	e	TBD	TBD	TBD	TBD	TBD	TBD
	f	TBD	TBD	TBD	TBD	TBD	TBD
Note: The minimum requirements for P-GSM 900 and E-GSM 900 are specified as minimum							

Annex E (normative): Estimation of Measurement Uncertainty

Editor's note: The following aspects are either missing or not yet determined:

- The head and hand phantom and hand only phantom configurations are TBD

Individual uncertainty contributions in the TRP and TRS measurements are discussed and evaluated in this Appendix. A technique for calculating the total measurement uncertainty is also presented. More detailed discussion on the uncertainty contributions can be found from [4].

The TRP/TRS measurement procedure can be considered to include two stages. In Stage 1 the actual measurement of the 3-D pattern of the Device Under Test (DUT) is performed. In Stage 2 the calibration of the absolute level of the DUT measurement results is performed by means of using a calibration antenna whose absolute gain/radiation efficiency is known at the frequencies of interest. The uncertainty contributions related to TRP are listed in Table E.1 and the contributions related to TRS are in Table A.2. The uncertainty contributions are analyzed in the following paragraphs.

The calculation of the uncertainty contribution is based on the ISO Guide to the expression of uncertainty in measurement. Each individual uncertainty is expressed by its Standard Deviation (termed here as 'standard uncertainty') and represented by symbol U . The uncertainty contributions can be classified to two categories: Type-A uncertainties, which are statistically determined e.g. by repeated measurements, and Type-B uncertainties, which are derived from existing data e.g. data sheets. Several individual uncertainties are common in Stage 1 and Stage 2 and therefore cancel.

The procedure of forming the uncertainty budget in TRP measurement is:

- 1) Compile lists of individual uncertainty contributions for TRP measurement both in Stage 1 and Stage 2.
- 2) Determine the standard uncertainty of each contribution by
 - a) Determining the distribution of the uncertainty (Gaussian, U-shaped, rectangular, etc.)
 - b) Determining the maximum value of each uncertainty (unless the distribution is Gaussian)
 - c) Calculating the standard uncertainty by dividing the uncertainty by $\sqrt{2}$ if the distribution is U-shaped, and by $\sqrt{3}$ if the distribution is rectangular.
- 3) Convert the units into decibel, if necessary.
- 4) Combine all the standard uncertainties by the Root of the Sum of the Squares (RSS) method.
- 5) Combine the total uncertainties in Stage 1 and Stage 2 also by the RSS method:

$$u_c = \sqrt{u_{c,DUT\ measurement}^2 + u_{c,calibration\ measurement}^2}$$
- 6) Multiply the result by an expansion factor of 1.96 to derive expanded uncertainty at 95% confidence level: $1.96 * u_c$.

Example uncertainty budgets are presented in Tables E.5, E.6, E.7, E.8, E.9, E.10, E.11, E.12, E.13 and E.14.

Table E.1: Uncertainty contributions in TRP measurement

Description of uncertainty contribution	Details in paragraph
Stage 1, DUT measurement	
1) Mismatch of receiver chain (i.e. between probe antenna and measurement receiver)	E.1-E.2
2) Insertion loss of receiver chain	E.3-E.5
3) Influence of the probe antenna cable	E.6
4) Uncertainty of the absolute antenna gain of the probe antenna	E.7
5) Measurement Receiver: uncertainty of the absolute level	E.8
6) Measurement distance: <ul style="list-style-type: none"> a) offset of DUT phase centre from axis(es) of rotation b) mutual coupling between the DUT and the probe antenna c) phase curvature across the DUT 	E.9
7) Quality of quiet zone	E.10
8) DUT Tx-power drift	E.11
9) Uncertainty related to the use of phantoms: (applicable when a phantom is used): <p>If SAM head phantom is used:</p> <ul style="list-style-type: none"> a) uncertainty from using different types of SAM phantom b) simulated tissue liquid uncertainty c) effect of the DUT holder <p>If SAM head and hand phantoms are used: TBD</p> <p>If a hand phantom is used: TBD</p> <p>If a laptop ground plane phantom is used:</p> <ul style="list-style-type: none"> a) Uncertainty related to the use of the Laptop Ground Plane phantom 	E.12
10) Coarse sampling grid	E.13
11) Random uncertainty (repeatability, including positioning uncertainty of the DUT against the SAM phantom or DUT plugged into the Laptop Ground Plane phantom)	E.14
Stage 2, Calibration measurement, network analyzer method, figure 7.5	
12) Uncertainty of network analyzer	E.15
13) Mismatch of receiver chain	E.1-E.2
14) Insertion loss of receiver chain	E.3-E.5
15) Mismatch in the connection of calibration antenna	E.1
16) Influence of the calibration antenna feed cable	E.6
17) Influence of the probe antenna cable	E.6
18) Uncertainty of the absolute gain of the probe antenna	E.7
19) Uncertainty of the absolute gain/ radiation efficiency of the calibration antenna	E.16
20) Measurement distance: <ul style="list-style-type: none"> a) Offset of calibration antenna's phase centre from axis(es) of rotation b) Mutual coupling between the calibration antenna and the probe antenna c) Phase curvature across the calibration antenna 	E.9
21) Quality of quiet zone	E.10

Table E.2: Uncertainty contributions in TRS measurement

Description of uncertainty contribution	Details in paragraph
Stage 1, DUT measurement	
1) Mismatch of transmitter chain (i.e. between probe antenna and base station simulator)	E.1-E.2
2) Insertion loss of transmitter chain	E.3-E.5
3) Influence of the probe antenna cable	E.6
4) Uncertainty of the absolute antenna gain of the probe antenna	E.7
5) Base station simulator: uncertainty of the absolute output level	E.17
6) BER measurement: output level step resolution	E.18
7) Statistical uncertainty of BER measurement	E.19
8) BER data rate normalization	E.20
9) Measurement distance: a) offset of DUT phase centre from axis(es) of rotation b) mutual coupling between the DUT and the probe antenna c) phase curvature across the DUT	E.9
10) Quality of quiet zone	E.10
11) DUT sensitivity drift	E.21
12) Uncertainty related to the use of phantoms: (applicable when a phantom is used): If a SAM head phantom is used: a) uncertainty from using different types of SAM phantom b) simulated tissue liquid uncertainty c) effect of the DUT holder If SAM head and hand phantoms are used: TBD If a hand phantom is used: TBD If a laptop ground plane phantom is used: a) Uncertainty related to the use of the Laptop Ground Plane phantom	E.12
13) Coarse sampling grid	E.13
14) Random uncertainty (repeatability) - positioning uncertainty of the DUT against the SAM or DUT plugged into the Laptop Ground Plane phantom	E.14
Stage 2, Calibration measurement, network analyzer method, figure 7.5	
15) Uncertainty of network analyzer	E.15
16) Mismatch in the connection of transmitter chain (i.e. between probe antenna and NA)	E.1-E.2
17) Insertion loss of transmitter chain	E.3-E.5
18) Mismatch in the connection of calibration antenna	E.1
19) Influence of the calibration antenna feed cable	E.6
20) Influence of the probe antenna cable	E.6
21) Uncertainty of the absolute gain of the probe antenna	E.7
22) Uncertainty of the absolute gain/radiation efficiency of the calibration antenna	E.16
23) Measurement distance: a) Offset of calibration antenna's phase centre from axis(es) of rotation b) Mutual coupling between the calibration antenna and the probe antenna c) Phase curvature across the calibration antenna	E.9
25) Quality of quiet zone	E.10

If a network analyzer is not available for calibration measurement and a spectrum analyzer or a power meter is used, Stage 2 errors in Tables 1 and 2 shall be replaced by Table 3.

Table E.3: Uncertainty contributions in Stage 2 (calibration measurement, spectrum analyzer method)

Description of uncertainty contribution	Details in paragraph
Stage 2, calibration measurement, spectrum analyser method, figure 7.4	
1) Cable loss measurement uncertainty	E.22
2) Uncertainty from impedance mismatch between the signal generator and the calibration antenna	E.1
3) Impedance mismatch uncertainty between the measurement receiver and the probe antenna	E.1
4) Signal generator: uncertainty of the absolute output level	E.23
5) Signal generator: output level stability	E.24
6) Influence of the calibration antenna feed cable	E.6
7) Influence of the probe antenna cable	E.6
8) Insertion loss of the calibration antenna feed cable	E.25
9) Insertion loss of the probe antenna cable	E.3
10) Mismatch uncertainty: between signal generator and calibration antenna (if antenna attenuator is used)	E.1
11) Mismatch uncertainty: between measurement receiver and probe antenna (if antenna attenuator is used)	E.1
12) Insertion loss of the calibration antenna attenuator (if used)	E.26
13) Insertion loss of the probe antenna attenuator (if used)	E.4
14) Uncertainty of the absolute level of the measurement receiver	E.8
15) Uncertainty of the absolute gain of the probe antenna	E.7
16) Uncertainty of the absolute gain of the calibration antenna	E.16
18) Measurement distance: <ul style="list-style-type: none"> a) Offset of calibration antenna's phase centre from axis(es) of rotation b) Mutual coupling between the calibration antenna and the probe antenna c) Phase curvature across the calibration antenna 	E.9
17) Quality of quiet zone	E.10

Table E.3.a: Uncertainty contributions in TRP measurement for reverberation chamber method

Description of uncertainty contribution	Details in paragraph
Stage 1, DUT measurement	
1) Mismatch of receiver chain (i.e. between fixed measurement antenna and measurement receiver)	E.1-E.2
2) Insertion loss of receiver chain	E.3-E.5
3) Influence of the fixed measurement antenna cable	E.6
4) Uncertainty of the absolute antenna gain of the fixed measurement antenna	E.7
5) Measurement Receiver: uncertainty of the absolute level	E.8
6) Chamber statistical ripple and repeatability	E.26.A
7) Additional power loss in EUT chassis	E.26.B
8) DUT Tx-power drift	E.11
9) Uncertainty related to the use of the SAM phantom: a) uncertainty from using different types of SAM phantom b) simulated tissue liquid uncertainty c) effect of the DUT holder	E.12
10) Random uncertainty (repeatability, including positioning uncertainty of the DUT against the SAM phantom or DUT plugged into the Laptop Ground Plane phantom)	E.14
11) Uncertainty related to the use of the Laptop Ground Plane phantom	E.31
Stage 2 , Calibration measurement, network analyzer method, figure 7.5	
12) Uncertainty of network analyzer	E.15
13) Mismatch of receiver chain	E.1-E.2
14) Insertion loss of receiver chain	E.3-E.5
15) Mismatch in the connection of calibration antenna	E.1
16) Influence of the calibration antenna feed cable	E.6
17) Influence of the fixed measurement antenna cable	E.6
18) Uncertainty of the absolute gain of the fixed measurement antenna	E.7
19) Uncertainty of the absolute gain/ radiation efficiency of the calibration antenna	E.16
20) Chamber statistical ripple and repeatability	E.26.A

Table E.3.b: Uncertainty contributions in TRS measurement for reverberation chamber method

Description of uncertainty contribution	Details in paragraph
Stage 1, DUT measurement	
1) Mismatch of transmitter chain (i.e. between fixed measurement antenna and base station simulator)	E.1-E.2
2) Insertion loss of transmitter chain	E.3-E.5
3) Influence of the fixed measurement antenna cable	E.6
4) Uncertainty of the absolute antenna gain of the fixed measurement antenna	E.7
5) Base station simulator: uncertainty of the absolute output level	E.17
6) BER measurement: output level step resolution	E.18
7) Statistical uncertainty of BER measurement	E.19
8) BER data rate normalization	E.20
9) Chamber statistical ripple and repeatability	E.26.A
10) Additional power loss in EUT chassis	E.26.B
11) DUT sensitivity drift	E.21
12) Uncertainty related to the use of the SAM phantom: a) uncertainty from using different types of SAM phantom b) simulated tissue liquid uncertainty c) effect of the DUT holder	E.12
13) Random uncertainty (repeatability) - positioning uncertainty of the DUT against the SAM or DUT plugged into the Laptop Ground Plane phantom)	E.14
14) Uncertainty related to the use of the Laptop Ground Plane phantom	E.31
Stage 2, Calibration measurement, network analyzer method, figure 7.5	
15) Uncertainty of network analyzer	E.15
16) Mismatch of receiver chain	E.1-E.2
17) Insertion loss of receiver chain	E.3-E.5
18) Mismatch in the connection of calibration antenna	E.1
19) Influence of the calibration antenna feed cable	E.6
20) Influence of the fixed measurement antenna cable	E.6
21) Uncertainty of the absolute gain of the fixed measurement antenna	E.7
22) Uncertainty of the absolute gain/ radiation efficiency of the calibration antenna	E.16
23) Chamber statistical ripple and repeatability	E.26.A

If a network analyzer is not available for calibration measurement and a spectrum analyzer or a power meter is used, Stage 2 errors in Tables 1 and 2 shall be replaced by Table 3.

Table E.3.c: Uncertainty contributions in Stage 2 (calibration measurement, spectrum analyzer method) for the reverberation chamber method

Description of uncertainty contribution	Details in paragraph
Stage 2, calibration measurement, spectrum analyser method, figure 7.4	
1) Cable loss measurement uncertainty	E.22
2) Uncertainty from impedance mismatch between the signal generator and the calibration antenna	E.1
3) Impedance mismatch uncertainty between the measurement receiver and the fixed measurement antenna	E.1
4) Signal generator: uncertainty of the absolute output level	E.23
5) Signal generator: output level stability	E.24
6) Influence of the calibration antenna feed cable	E.6
7) Influence of the fixed measurement antenna cable	E.6
8) Insertion loss of the calibration antenna feed cable	E.25
9) Insertion loss of the fixed measurement antenna cable	E.3
10) Mismatch uncertainty: between signal generator and calibration antenna (if antenna attenuator is used)	E.1
11) Mismatch uncertainty: between measurement receiver and fixed measurement antenna (if antenna attenuator is used)	E.1
12) Insertion loss of the calibration antenna attenuator (if used)	E.26
13) Insertion loss of the fixed measurement antenna attenuator (if used)	E.4
14) Uncertainty of the absolute level of the measurement receiver	E.8
15) Uncertainty of the absolute gain of the fixed measurement antenna	E.7
16) Uncertainty of the absolute gain of the calibration antenna	E.16
19) Chamber statistical ripple and repeatability	E.26.A

E.1 Mismatch uncertainty between measurement receiver and the probe antenna

If the same chain configuration (including the measurement receiver; the probe antenna and other elements) is used in both stages, the uncertainty is considered systematic and constant → 0.00dB value.

If it is not the case, this uncertainty contribution has to be taken into account and should be measured or determined by the method described in [1].

E.2 FFS

E.3 Insertion loss of the probe antenna cable

If the probe antenna cable does not move between the calibration and the DUT measurement stage, the uncertainty due to the insertion loss of the cable is assumed to be systematic. Moreover, this uncertainty is common and constant in both stages and that is why this leads to 0.00dB value.

If a different cable is used in the calibration measurement and in the DUT measurement, and the difference of the insertion loss is used in the calculations, then the overall combined standard uncertainty of the insertion loss measurement should be used in the uncertainty budget. The distribution of this uncertainty is assumed to be rectangular, in which case the standard uncertainty can be calculated as the maximum value/ $\sqrt{3}$.

E.4 Insertion loss of the probe antenna attenuator (if used)

See Insertion loss of the probe antenna cable

If the probe antenna attenuator is used in both stages, the uncertainty is considered systematic and constant → 0.00dB value.

E.5 Insertion loss of the RF relays (if used)

See Insertion loss of the probe antenna cable.

If the RF relay is used in both stages, the uncertainty is considered systematic and constant → 0.00dB value.

E.6 Influence of the antenna cable

E.6.1 Probe antenna cable

If the probe antenna is directional (i.e. peak gain >+5dBi e.g. horn, LPDA, etc.) and the same probe antenna cable configuration is used for both stages, the uncertainty is considered systematic and constant → 0.00dB value.

In other cases a technical study should be done.

An ETSI technical report [4] gives a discussion on the results obtained by testing a vertically polarized biconical antenna over a ground plane with differing RF cable configurations.

E.6.2 Calibration antenna cable

If an efficiency calibration is performed, influence of the calibration antenna feed cable can be assumed to be negligible, due to data averaging.

In the case of gain calibration, the influence of the calibration antenna feed cable shall be assessed by measurements. A gain calibration measurement is repeated with a reasonably differing routing of the feed cable. Largest difference between the results is entered to the uncertainty budget with a rectangular distribution.

E.7 Absolute gain of the probe antenna

The uncertainty appears in the both stages and it is thus considered systematic and constant → 0.00dB value.

E.8 Measurement Receiver: uncertainty of absolute level

The receiving device is used to measure the received signal level in TRP tests either as an absolute level or as a relative level. Receiving device used is typically a Base Station Simulator (BSS), spectrum analyzer (SA), or power meter (PM). Generally there occurs an uncertainty contribution from limited absolute level accuracy and non-linearity.

E.9 Measurement distance

The uncertainty contribution from a finite measurement distance is estimated in three parts.

E.9.1 Offset of DUT phase centre from axis(es) of rotation

In all the measurements defined in this test procedure the DUT and phantom combination is rotated about the ear reference point of SAM phantom, which is also assumed to be the location of the phase centre in both angular directions of the measurements.

For some turntables this may be practically impossible in which case a measurement uncertainty contribution can arise because the phase centre will rotate on a non-zero radius about the centre of rotation, thereby giving a variable measurement distance. Data averaging process may lead to a partial self-cancel of this uncertainty.

The following formula is used to estimate this uncertainty contribution in stage 1:

$$U_{\text{phase_center_limits}} \text{ (dB)} = 10\log(d \pm \Delta d)^2 + 10\log(d)^2$$

If a gain calibration is performed in Stage 2, the uncertainty contribution of calibration antenna's displacement is estimated with the previous formula. Misalignment can be estimated with following formula,

$$U_{\text{misalignment}} \text{ (dB)} = 20\log(\cos \theta) ,$$

where θ is the misalignment angle between the calibration antenna and the probe antenna. The contribution shall be added to displacement error:

$$U_{\text{cal}} \text{ (dB)} = \sqrt{U_{\text{phase_center_}\Delta}^2 + U_{\text{misalignment}}^2}$$

For an efficiency calibration with an omnidirectional calibration antenna, the U_{cal} is calculated similarly as for gain calibration but the uncertainty may be divided by factor 2. This is due to correcting impact of data averaging in this type of calibration.

E.9.2 Mutual coupling

In measurement of radio performances of UMTS mobile phones in speech mode, the mutual coupling uncertainty for this frequency band is a 0.00dB value (see annex A -2 in [5]).

The 0.00dB value can be extended for the GSM; DCS and PCS band frequencies.

E.9.3 Phase curvature

This uncertainty originates from the finite far-field measurement distance, which causes phase curvature across the DUT. If the measurement distance is $> 10\lambda$, this error is assumed to be negligible. At 2 GHz λ is 0.15 m, thus 10λ is 1.5 m.

E.10 Quality of quiet zone

The uncertainty contribution of the reflectivity level of the anechoic chamber is determined from the average standard deviation of the electric field in the quiet zone. By repeating a free space VSWR measurement in 15-degree grid in elevation and azimuth, 264 standard deviation values in both polarizations are determined. From these values average standard deviation of electric field in the quiet zone can be calculated from the equation:

$$\frac{S}{S_{\text{freq}}} = \frac{\frac{\pi}{2NM} \sum_{n=1}^N \sum_{m=1}^M s_{n,m,hor} \sin(\theta_n) + \frac{\pi}{2NM} \sum_{n=1}^N \sum_{m=1}^M s_{n,m,ver} \sin(\theta_n)}{2}$$

where

N is number of angular intervals in elevation,

M is number of angular intervals in azimuth and

θ_n is elevation of single measurement $s_{n,m,pol}$.

If an efficiency calibration with omnidirectional calibration antenna is performed, the effect of reflectivity level decreases in Stage 2 and $\overline{S_{freq}}$ may be divided by factor 2. This is due to correcting impact of data averaging in this type of calibration. Efficiency calibration done with sampling step $\leq 30^\circ$, can be considered to have at least four independent samples. $\overline{S_{freq}}$ may be divided by factor 2 also in stage 1 for the same reason.

It's likely that asymmetry of the field probe will have a very small impact on this measurement uncertainty contributor, however, an upper bound to probe symmetry should be considered.

E.11 Tx-power drift of DUT

A single point power reference measurement in the beginning and at the end of the measurement procedure is recommended to monitor the power drift of the DUT. Based on TX-power drift measurements for typical 3G UE the determination of this contribution is performed by measuring the Tx-power drift and the value shall be included in the uncertainty budget.

In order to minimize Tx-power drift error it's recommended to interleave sensitivity and power measurement of multiple channels. This spreads the measurements over a longer period, which helps to average the drift of the TX-power.

E.12 Uncertainty related to the use of phantom

E.12.1 Uncertainty from using different types of SAM phantom

This uncertainty contribution originates from the fact that different laboratories may use the two different versions of SAM head: the SAM head phantom or the SAM phantom including the head and the shoulders. The standard SAM head is the specified phantom. However, the use of the other type of SAM is also allowed with the requirement that the resulting uncertainty contribution is taken into account in the uncertainty budget.

E.12.2 Simulated tissue liquid uncertainty

This uncertainty will occur, if the laboratory uses a liquid which has dielectric parameters deviating from the target parameters given in chapter Annex A. The relative dielectric constant (ϵ_r) and conductivity (σ) of used material shall be maintained within $\pm 25\%$ of target properties listed in Annex A. To convert electrical parameters of the tissue stimulant ϵ_r and σ to uncertainty values following equation shall be used:

$$U_{electrical} = 0.5dB \frac{\sqrt{\left(\frac{\epsilon_r - \epsilon_{r_target}}{\epsilon_{r_target}}\right)^2 + \left(\frac{\sigma_r - \sigma_{r_target}}{\sigma_{r_target}}\right)^2}}{\sqrt{25\%^2 + 25\%^2}}$$

E.12.3 Device Holder

This uncertainty contribution originates from interaction of the Device Holder (the supporting structure of low-loss dielectric material that is used to hold the handset under-test in the desired position during measurement, as defined in the IEEE 1528) and the DUT. The Device Holder Uncertainty contribution depends on the different laboratories implementation and on the shape and manufacturing material. The Device Holder has an influence that varies with the relative position with respect to the DUT Antenna. Due to this the Device Holder should be designed to have maximum distance between Device Holder and DUT Antenna. The fixed value 0.2 dB is used to estimate the impact of device

holder in uncertainty calculation. The determination of this contribution is performed by measuring the TRP and TRS with and without the holder.

E.12.4 Uncertainty of dielectric properties and shape of the hand phantom

TBD

E.12.5 Uncertainty from using different types of Laptop Ground Plane phantom

This uncertainty contribution originates from the fact that different laboratories may use different variations of Laptop Ground Plane phantom. Based on Section 5.1.3, the standard Laptop Ground Plane is the specified phantom.

E.13 Coarse sampling grid

Degreasing of sampling density to finite amount of samples affects the measurement uncertainty by two different errors. First is due to inadequate number of samples and second is a systematic discrimination approximation error in TRP and TRS equations.

The offset of systematic approximation error can be expressed by using formula

$$Offset = 10 \cdot \log_{10} \left(\frac{\pi}{2N} \sum_{n=1}^N \sin(\theta_n) \right).$$

where

N is number of angular intervals in elevation,

θ_n is elevation.

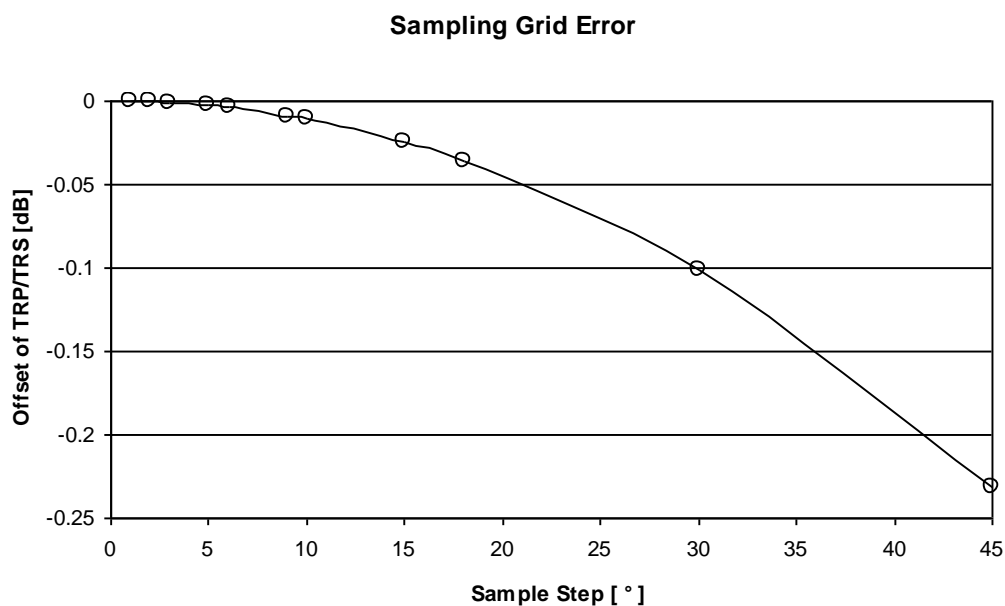

Figure E.7. Approximation error of TRP/TRS.

The 10° or 15° sampling grid used in TRP measurements has been shown to introduce only very small differences as compared to the results obtained with denser grids, so with that sampling grid the uncertainty contribution can be assumed negligible.

When using sample step size of 15° - 30°, standard uncertainty of 0.15dB can be assumed to cover errors.

E.14 Random uncertainty

The random uncertainty characterizes the undefined and miscellaneous effects which cannot be forecasted. One can estimate this type of uncertainty with a repeatability test by making a series of repeated measurements with a reference DUT without changing anything in the measurement set-up.

The random uncertainty differs from one laboratory to another. Moreover, each DUT has its own electromagnetic behaviour and random uncertainty. Some uncertainty also occurs from the positioning of the DUT against the SAM phantom, as the DUT cannot be attached exactly in the same way every time. This uncertainty depends on how much the DUT's positioning against the SAM phantom varies from the specified testing positions. It is noted that the uncertainty of the phone positioning depends on the phone holder and the measurement operator and is in fact difficult to distinguish from random uncertainty. Some uncertainty also occurs from the positioning of the DUT plugged into the Laptop Ground Plane phantom, as the DUT may not be plugged into the USB connector and positioned exactly in the same way every time. This uncertainty depends on how much the DUT's position plugged into the Laptop Ground Plane phantom varies from the specified plug-in position. Therefore, the positioning uncertainty is included in random uncertainty.

To estimate this uncertainty for the SAM phantom, it is suggested to perform at least five evaluations of TRP/TRS whereby the device shall be dismantled and newly positioned with a fully charged battery before each test. This measurement set has to be carried out in mid channel of lowest and highest frequency bands utilized by the testing lab, for at least three phones with different types of mechanical design. The values have to be normalized by the mean for each measurement set. As a result the uncertainty contribution entered to uncertainty budget is the difference between the maximum and minimum normalized value.

To estimate this uncertainty for the Laptop Ground Plane phantom, it is suggested to perform at least five evaluations of TRP/TRS for the plug-in position whereby the device shall be dismantled and newly positioned before each test. This measurement set has to be carried out in mid channel of lowest and highest frequency bands utilized by the testing lab, for at least three USBs with different types of mechanical design. The values have to be normalized by the mean for each measurement set. As a result the uncertainty contribution entered to uncertainty budget is the difference between the maximum and minimum normalized value.

E.15 Uncertainty of network analyzer

This uncertainty includes all uncertainties involved in the S21 measurement with a network analyzer, and will be calculated from the manufacturer's data in logs with a rectangular distribution, unless otherwise informed, (see clause 5.1.2 in [6]).

E.16 Uncertainty of the gain/efficiency of the calibration antenna

The calibration antenna only appears in Stage 2. Therefore, the gain/efficiency uncertainty has to be taken into account.

This uncertainty will be calculated from the manufacturer's data in logs with a rectangular distribution, unless otherwise informed (see clause 5.1.2 in [6]).

If the manufacturer's data do not give the information, the value has to be checked, see annex A-12 in [5]

E.17 Base station simulator: uncertainty of the absolute level

The transmitter device (typically a BS Simulator) is used to drive a signal to the horn antenna in sensitivity tests either as an absolute level or as a relative level. Receiving device used is typically a UE/MS. Generally there occurs uncertainty contribution from limited absolute level accuracy and non-linearity of the BS Simulator.

For practical reasons, the calibration measurement (Stage 2) should be only performed with the probe antenna as a receiver. Hence, the uncertainty on the absolute level of the transmitter device cannot be assumed as systematic. This uncertainty should be calculated from the manufacturer's data in logs with a rectangular distribution, unless otherwise informed (see clause 5.1.2 in [6]). Furthermore, the uncertainty of the non-linearity of the device is included in the absolute level uncertainty.

E.18 BER measurement: output level step resolution

When output power of the BS simulator is swept to reach the BER target, used power step resolution creates this uncertainty. Output power step used in the BER measurement is divided by factor 2 to obtain the uncertainty with rectangular distribution.

E.19 Statistical uncertainty of the BER measurement

To study statistical uncertainty of BER measurement, see ETSI document TR 100 028-1, section 6.6 [4].

For a full TRS measurement with a regular sampling grid, the statistical uncertainty can be approximated by using the following formula:

$$U_{fullTRS} = \frac{U_{SingleTRS}}{\sqrt{N/4}},$$

Where

$U_{SingleTRS}$ is the statistical uncertainty of single measurement,

N is the number of measurements.

E.19.1 WCDMA

For a BER target of $1\% \pm 0.2\%$ using 20000 bits, uncertainty of 0.19 dB for a single measurement can be used. Using a BER target of $10\% \pm 2\%$ with 20000 tested bits will lead to uncertainty of 0.46dB for a single measurement. If non standard settings are used to determine EIS the statistical error of the measurement should be estimated according to ETSI document TR 100 028-1.

E.19.2 GSM

For a BER target of $2.00\% \pm 0.2\%$ using 10000 bits, uncertainty of 0.13 dB for a single measurement can be used. If non standard settings are used to determine EIS the statistical error of the measurement should be estimated according to ETSI document TR 100 028-1.

For a BLER target of $10\% \pm 2\%$ with 20000 tested bits will lead to uncertainty of 0.46dB for a single measurement. If non standard settings are used to determine EIS the statistical error of the measurement should be estimated according to ETSI document TR 100 028-1.

E.19.3 TD-SCDMA

For a BER target of $1\% \pm 0.2\%$ using 40000 bits, uncertainty of 0.13 dB for a single measurement can be used. If non standard settings are used to determine EIS the statistical error of the measurement should be estimated according to ETSI document TR 100 028-1.

E.20 BER normalization uncertainty

This uncertainty occurs only when non standard settings are used to speed up TRS measurement. It can be calculated using following formula:

$$U_{norm} = \frac{\sqrt{\left(\frac{U_{SingleTRSref}}{2}\right)^2 + \left(\frac{U_{SingleTRSfst}}{2}\right)^2}}{\sqrt{N_{ref}}},$$

Where

$U_{SingleTRSref}$ is the statistical uncertainty of the used reference measurement,

$U_{SingleTRSfst}$ is the statistical uncertainty of the non standard measurement,

N_{ref} Is the number of measured reference points.

E.21 DUT sensitivity drift

Due to statistical uncertainty of BER measurement, drift in the TRS can not be monitored similarly to TRP. An uncertainty value of 0.2dB can be used, or the TRS drift should be measured, with a setup corresponding to the actual TRS measurement.

E.22 Cable loss measurement uncertainty

Before performing the calibration, cable losses have to be measured. This measurement includes a standard uncertainty, which is composed of the mismatch, and the insertion loss uncertainties. In the calibration measurement, the transmitter part is composed with the calibration antenna, cables, and signal generator. The receiver part is composed with the probe antenna, cables, and measurement device.

The cable loss of transmitter and receiver parts should be measured separately. By this way, the cable losses will be compliant with the cable routing of the calibration stage. On the opposite, if the cable losses were measured together at the same time, the measured values would include errors from miscellaneous mismatch contributions, which do not appear in the cable routing of the calibration stage.

The cable loss measurement uncertainty is the result of the RSS of the uncertainty contributions listed in Table E.4.

Table E.4: Uncertainty contributions in the cable loss measurement

Description of uncertainty contribution	Standard Uncertainty (dB)
Mismatch uncertainty of cable(s) receiver part	
Insertion loss of the cable(s) receiver part	
Measurement device: absolute level uncertainty	
Measurement device: linearity	
Mismatch uncertainty of cable(s) transmitter part	
Insertion loss of the cable(s) transmitter part	
Signal generator: absolute output level uncertainty	
Signal generator: output level stability uncertainty	
Cable loss measurement uncertainty (RSS)	

E.23 Signal generator: uncertainty of the absolute output level

The signal generator is only used at this stage. It substitutes the DUT by feeding the calibration antenna with a known power level. The use of this signal generator introduces an uncertainty on the absolute output level.

This uncertainty will be calculated from the manufacturer's data in logs with a rectangular distribution (see clause 5.1.2 in [6]).

E.24 Signal generator: output level stability

The uncertainty on the output level stability has to be taken into account only when the uncertainty of the absolute level is not considered.

This uncertainty will be calculated from the manufacturer's data in logs with a rectangular distribution (see clause 5.1.2 in [6]).

E.25 Insertion loss: Calibration antenna feed cable

The feed cable of the calibration antenna only appears in Stage 2. As a result, this uncertainty has to be taken into account.

This uncertainty will be measured or calculated from the manufacturer's data in logs with a rectangular distribution (see clause 5.1.2 in [6]).

E.26 Insertion loss: Calibration antenna attenuator (if used)

If a calibration antenna attenuator is used, it only appears in Stage 2. As a result, this uncertainty has to be taken into account.

This uncertainty will be calculated from the manufacturer's data in logs with a rectangular distribution (see clause 5.1.2 in [6]).

E.26.A Chamber Statistical Ripple and Repeatability

The uncertainty due to chamber statistics is determined by repeated calibration measurements as described in Annex G.A. This uncertainty contribution is a composite value consisting of most of the specific reverberation chamber contributions, such as limited number of modes and mode-stirring techniques.

The uncertainty contribution value shall be determined by measurements as described in Annex G.A and be assumed to have a normal distribution.

E.26.B Additional Power Loss in EUT Chassis

When the EUT is small and do not add noticeable loss to the chamber, the calibration procedure outlined in section B.2, is performed without the EUT present in the chamber. The possible difference in average chamber transmission level between the EUT measurement and the reference measurement must in this case be considered in the uncertainty evaluation.

The uncertainty value for this contribution can be tested empirically by choosing a unit within a set of samples which is considered to incur the highest amount of loss (normally the largest unit), and measure the average transmission loss in the chamber with and without the test unit present in the chamber. The difference between the two cases shall be used in the uncertainty calculation and the distribution should be assumed to be rectangular.

Alternatively, a fixed value of 0.2 dB with a rectangular distribution can be used in the uncertainty calculations.

E.27 Examples of uncertainty budget calculations for TRP(Informative)

Editor's note: The following aspects are either missing or not yet determined:

- The head and hand phantom and hand only phantom configurations are TBD

Table E.5: Example of uncertainty budget for head only TRP measurement

Uncertainty Source	Comment	Uncertainty Value [dB]	Prob Distr	Div	ci	Standard Uncertainty [dB]
STAGE 1 (DUT measurement)						
1) Mismatch of receiver chain	$\Gamma_{\text{power meter}} < 0.05$ $\Gamma_{\text{probe antenna connection}} < 0.16$	0.05	U	$\sqrt{2}$	1	0.04
2) Insertion loss of receiver chain	Systematic with Stage 2 (=> cancels)	0	R	$\sqrt{3}$	1	0
3) Influence of the probe antenna cable	Systematic with Stage 2 (=> cancels)	0	R	$\sqrt{3}$	1	0
4) Absolute antenna gain of the probe antenna	Systematic with Stage 2 (=> cancels)	0	R	$\sqrt{3}$	1	0
5) Measurement Receiver: uncertainty of the absolute level	Power Meter	0.06	R	$\sqrt{3}$	1	0.03
6) Measurement distance a) Offset of DUT phase centre	$\Delta d = 0.05\text{m}$	0.14	R	$\sqrt{3}$	1	0.08
7) Quality of quiet zone	Standard deviation of E-field in QZ measurement	0.5	N	1	1	0.5
8) DUT Tx-power drift	Drift	0.2	R	$\sqrt{3}$	1	0.12
9) a) Uncertainty related to the use of SAM phantom:	Standard SAM head with standard tissue simulant	0	R	$\sqrt{3}$	1	0
b) Simulated tissue liquid uncertainty	Maximum allowed error	0.5	R	$\sqrt{3}$	1	0.29
c) Effect of DUT holder	Fixed value	0.2	R	$\sqrt{3}$	1	0.12
10) Coarse sampling grid	Negligible, used $\Delta_{\theta} = 15^{\circ}$ and $\Delta_{\phi} = 15^{\circ}$.	0	N	1	1	0
11) Repeatability	Monoblock, clamshell, slide design	0.4	R	$\sqrt{3}$	1	0.23
STAGE 2 (Calibration)						
12) Uncertainty of network analyzer	Manufacturer's uncertainty calculator, covers whole NA setup	0.5	R	$\sqrt{3}$	1	0.29
13) Mismatch of receiver chain	Taken in to account in NA setup uncertainty	0	U	$\sqrt{2}$	1	0
14) Insertion loss of receiver chain	Systematic with Stage 1 (=> cancels)	0	R	$\sqrt{3}$	1	0
15) Mismatch in the connection of calibration antenna	Taken in to account in NA setup uncertainty	0	U	$\sqrt{2}$	1	0
16) Influence of the feed cable of the calibration antenna	Gain calibration with a dipole	0.3	R	$\sqrt{3}$	1	0.17
17) Influence of the probe antenna cable	Systematic with Stage 1 (=> cancels)	0	R	$\sqrt{3}$	1	0
18) Uncertainty of the absolute gain of the probe antenna	Systematic with Stage 1 (=> cancels)	0	R	$\sqrt{3}$	1	0
19) Uncertainty of the absolute gain of the calibration antenna	Calibration certificate	0.5	R	$\sqrt{3}$	1	0.29
20) Measurement distance: - Calibration antenna's displacement and misalignment	$d = 3\text{m}$, $\Delta d = 0.05\text{m}$, $\theta = 2^{\circ}$	0.29	R	$\sqrt{3}$	1	0.17
21) Quality of quiet zone	Standard deviation of e-field in QZ measurement, Gain calibration	0.5	N	1	1	0.5

Combined standard uncertainty	$u_c = \sqrt{\sum_{i=1}^m c_i^2 \cdot u_i^2}$				0.95
Expanded uncertainty (Confidence interval of 95 %)			$u_e = 1,96 u_c$		1.86

Table E.6: Example of uncertainty budget for TRP head+hand (speech mode) measurement

TBD

Table E.7: Example of uncertainty budget for TRP hand only (browsing mode) measurement

TBD

Table E.8: Example of uncertainty budget for TRP measurement with laptop ground plane phantom

Uncertainty Source	Comment	Uncertainty Value [dB]	Prob Distr	Div	ci	Standard Uncertainty [dB]
STAGE 1 (DUT measurement)						
1) Mismatch of receiver chain	$\Gamma_{\text{power meter}} < 0.05$ $\Gamma_{\text{probe antenna connection}} < 0.16$	0.05	N	1	1	0.05
2) Insertion loss of receiver chain	Systematic with Stage 2 (=> cancels)	0	R	$\sqrt{2}$	1	0
3) Influence of the probe antenna cable	Systematic with Stage 2 (=> cancels)	0	R	$\sqrt{3}$	1	0
4) Absolute antenna gain of the probe antenna	Systematic with Stage 2 (=> cancels)	0	R	$\sqrt{3}$	1	0
5) Measurement Receiver: uncertainty of the absolute level	Power Meter	0.06	R	$\sqrt{3}$	1	0.03
6) Measurement distance a) Offset of DUT phase center	$\Delta d = 0.05\text{m}$	0.14	R	$\sqrt{3}$	1	0.08
7) Quality of quiet zone	Standard deviation of E-field in QZ measurement	0.5	N	1	1	0.5
8) DUT Tx-power drift	Drift	0.2	R	$\sqrt{3}$	1	0.12
9) Uncertainty related to the use of laptop ground plane phantom:	Standard laptop phantom	0	R	$\sqrt{3}$	1	0
10) Coarse sampling grid	Negligible, used $\Delta_{\theta} = 15^{\circ}$ and $\Delta_{\varphi} = 15^{\circ}$.	0	N	1	1	0
11) Repeatability	horizontal USB design, rotary USB porter, and non-rotary USB porter used for testing	0.4	R	$\sqrt{3}$	1	0.23
STAGE 2 (Calibration)						
12) Uncertainty of network analyzer	Manufacturer's uncertainty calculator, covers whole NA setup	0.5	R	$\sqrt{3}$	1	0.29
13) Mismatch of receiver chain	Taken in to account in NA setup uncertainty	0	U	$\sqrt{2}$	1	0
14) Insertion loss of receiver chain	Systematic with Stage 1 (=> cancels)	0	R	$\sqrt{3}$	1	0
15) Mismatch in the connection of calibration antenna	Taken in to account in NA setup uncertainty	0	U	$\sqrt{2}$	1	0
16) Influence of the feed cable of the calibration antenna	Gain calibration with a dipole	0.3	R	$\sqrt{3}$	1	0.17
17) Influence of the probe antenna cable	Systematic with Stage 1 (=> cancels)	0	R	$\sqrt{3}$	1	0
18) Uncertainty of the absolute gain of the probe antenna	Systematic with Stage 1 (=> cancels)	0	R	$\sqrt{3}$	1	0
19) Uncertainty of the absolute gain of the calibration antenna	Calibration certificate	0.5	R	$\sqrt{3}$	1	0.29
20) Measurement distance: Calibration antenna's displacement and misalignment	$d = 3\text{m}$, $\Delta d = 0.05\text{m}$, $\theta = 2^{\circ}$	0.29	R	$\sqrt{3}$	1	0.17
21) Quality of quiet zone	Standard deviation of e-field in QZ measurement, Gain calibration	0.5	N	1	1	0.5
Combined standard uncertainty	$u_c = \sqrt{\sum_{i=1}^m c_i^2 \cdot u_i^2}$					0.89
Expanded uncertainty (Confidence interval of 95 %)			$u_e = 1.96 u_c$			1.75

E.28 Examples of uncertainty budget calculations for TRS(Informative)

Table E.9: Example of uncertainty budget for TRS head only measurement

Uncertainty Source	Comment	Uncertainty Value [dB]	Prob Distr	Div	ci	Standard Uncertainty [dB]
STAGE 1 (DUT measurement)						
1) Mismatch of transmitter chain	$\Gamma_{\text{BSS}} < 0.13$ $\Gamma_{\text{antenna connection}} < 0.03$	0.02	N	1	1	0.02
2) Insertion loss of transmitter chain	Systematic with Stage 1 (=> cancels)	0	R	$\sqrt{3}$	1	0
3) Influence of the probe antenna cable	Systematic with Stage 2 (=> cancels)	0	R	$\sqrt{3}$	1	0
4) Absolute antenna gain of the probe antenna	Systematic with Stage 2 (=> cancels)	0	R	$\sqrt{3}$	1	0
5) Base station simulator: uncertainty of the absolute level		1	R	$\sqrt{3}$	1	0.58
6) BER measurement: output level step resolution	Step 0.1dB	0.05	R	$\sqrt{3}$	1	0.03
7) Statistical uncertainty of the BER measurement	BER target 10%±2% , 20000 tested bits , N=60	0.12	N	1	1	0.12
8) TRS data rate normalization	4 reference points measured	0.12	N	1	1	0.12
9) Measurement distance a) Offset of DUT phase centre	$\Delta d = 0.05\text{m}$	0.14	R	$\sqrt{3}$	1	0.08
10) Quality of quiet zone	Standard deviation of E-field in QZ measurement	0.5	N	1	1	0.5
11) DUT sensitivity drift	Drift measurement	0.2	R	$\sqrt{3}$	1	0.12
12) a) Uncertainty related to the use of SAM phantom:	Standard SAM with standard tissue simulant	0	R	$\sqrt{3}$	1	0
b) Simulated tissue liquid uncertainty	Maximum allowed error	0.5	R	$\sqrt{3}$	1	0.29
c) Effect of DUT holder	Fixed value	0.2	R	$\sqrt{3}$	1	0.12
13) Coarse sampling grid	$\Delta_{\theta} = 30^{\circ}$ and $\Delta_{\varphi} = 30^{\circ}$.	0.15	N	N	1	0.15
14) Repeatability	Monoblock, clamshell, slide design	0.5	R	$\sqrt{3}$	1	0.29
STAGE 2 (Calibration)						
15) Uncertainty of network analyzer	Manufacturer's uncertainty calculator, covers NA setup	0.5	R	$\sqrt{3}$	1	0.29
16) Mismatch of transmitter chain	Taken in to account in NA setup uncertainty	0	U	$\sqrt{2}$	1	0
17) Insertion loss of transmitter chain	Systematic with Stage 1 (=> cancels)	0	R	$\sqrt{3}$	1	0
18) Mismatch in the connection of calibration antenna	Taken in to account in NA setup uncertainty	0	R	$\sqrt{3}$	1	0
19) Influence of the feed cable of the calibration antenna	Gain calibration with dipole	0.3	R	$\sqrt{3}$	1	0.17
20) Influence of the probe antenna cable	Systematic with Stage 1 (=> cancels)	0	R	$\sqrt{3}$	1	0
21) Uncertainty of the absolute gain of the probe antenna	Systematic with Stage 1 (=> cancels)	0	R	$\sqrt{3}$	1	0

22) Uncertainty of the absolute gain of the calibration antenna	Calibration certificate	0.5	R	$\sqrt{3}$	1	0.29
23) Measurement distance: Calibration antenna's displacement and misalignment	$d=3\text{m}, \Delta d=0.05\text{m}, \theta=2^\circ$	0.29	R	$\sqrt{3}$	1	0.17
24) Quality of quiet zone	Standard deviation of E-field in QZ measurement	0.5	N	1	1	0.5
Combined standard uncertainty	$u_c = \sqrt{\sum_{i=1}^m c_i^2 \cdot u_i^2}$					1.17
Expanded uncertainty (Confidence interval of 95 %)			$u_e = 1,96 u_c$			2.29

Table E.10: Example of uncertainty budget for TRS head+hand (speech mode) measurement

TBD

Table E.11: Example of uncertainty budget for TRS hand only (browsing mode) measurement

TBD

Table E.12: Example of uncertainty budget for TRS measurement with laptop ground plane phantom

Uncertainty Source	Comment	Uncertainty Value [dB]	Prob Distr	Div	ci	Standard Uncertainty [dB]
STAGE 1 (DUT measurement)						
1) Mismatch of transmitter chain	$\Gamma_{\text{BSS}} < 0.13$ $\Gamma_{\text{antenna connection}} < 0.03$	0.02	N	1	1	0.02
2) Insertion loss of transmitter chain	Systematic with Stage 1 (=> cancels)	0	R	$\sqrt{3}$	1	0
3) Influence of the probe antenna cable	Systematic with Stage 2 (=> cancels)	0	R	$\sqrt{3}$	1	0
4) Absolute antenna gain of the probe antenna	Systematic with Stage 2 (=> cancels)	0	R	$\sqrt{3}$	1	0
5) Base station simulator: uncertainty of the absolute level		1	R	$\sqrt{3}$	1	0.58
6) BER measurement: output level step resolution	Step 0.1dB	0.05	R	$\sqrt{3}$	1	0.03
7) Statistical uncertainty of the BER measurement	BER target 10%±2% , 20000 tested bits , N=60	0.12	N	1	1	0.12
8) TRS data rate normalization	4 reference points measured	0.12	N	1	1	0.12
9) Measurement distance a) Offset of DUT phase center	$\Delta d = 0.05\text{m}$	0.14	R	$\sqrt{3}$	1	0.08
10) Quality of quiet zone	Standard deviation of E-field in QZ measurement	0.5	N	1	1	0.5
11) DUT sensitivity drift	Drift measurement	0.2	R	$\sqrt{3}$	1	0.12
9) Uncertainty related to the use of laptop ground plane phantom	Standard laptop phantom	0	R	$\sqrt{3}$	1	0
13) Coarse sampling grid	$\Delta_\theta = 30^\circ$ and $\Delta_\phi = 30^\circ$.	0.15	N	N	1	0.15
14) Repeatability	horizontal USB design, rotary USB porter, and non-rotary USB porter used for testing	0.5	R	$\sqrt{3}$	1	0.29
STAGE 2 (Calibration)						
15) Uncertainty of network analyzer	Manufacturer's uncertainty calculator, covers NA setup	0.5	R	$\sqrt{3}$	1	0.29
16) Mismatch of transmitter chain	Taken in to account in NA setup uncertainty	0	U	$\sqrt{2}$	1	0
17) Insertion loss of transmitter chain	Systematic with Stage 1 (=> cancels)	0	R	$\sqrt{3}$	1	0
18) Mismatch in the connection of calibration antenna	Taken in to account in NA setup uncertainty	0	R	$\sqrt{3}$	1	0
19) Influence of the feed cable of the calibration antenna	Gain calibration with dipole	0.3	R	$\sqrt{3}$	1	0.17
20) Influence of the probe antenna cable	Systematic with Stage 1 (=> cancels)	0	R	$\sqrt{3}$	1	0
21) Uncertainty of the absolute gain of the probe antenna	Systematic with Stage 1 (=> cancels)	0	R	$\sqrt{3}$	1	0
22) Uncertainty of the absolute gain of the calibration antenna	Calibration certificate	0.5	R	$\sqrt{3}$	1	0.29
23) Measurement distance: Calibration antenna's displacement and misalignment	$d=3\text{m}$, $\Delta d=0.05\text{m}$, $\theta=2^\circ$	0.29	R	$\sqrt{3}$	1	0.17
24) Quality of quiet zone	Standard deviation of E-field in QZ measurement	0.5	N	1	1	0.5
Combined standard uncertainty	$u_c = \sqrt{\sum_{i=1}^m c_i^2 \cdot u_i^2}$					1.1
Expanded uncertainty (Confidence interval of 95 %)			$u_e = 1,96 u_c$			2.16

E.29 Examples of uncertainty budget calculations for TRP, reverberation chamber method (Informative)

-

Table E.13: Example of uncertainty budget for TRP measurement, reverberation chamber method

Uncertainty Source	Comment	Uncertainty Value [dB]	Prob Distr	Div	ci	Standard Uncertainty [dB]
STAGE 1 (DUT measurement)						
1) Mismatch of receiver chain	$\Gamma_{\text{power meter}} < 0.05$ $\Gamma_{\text{fixed measurement antenna connection}} < 0.16$	0.05	U	$\sqrt{2}$	1	0.04
2) Insertion loss of receiver chain	Systematic with Stage 2 (=> cancels)	0	R	$\sqrt{3}$	1	0
3) Influence of the fixed measurement antenna cable	Systematic with Stage 2 (=> cancels)	0	R	$\sqrt{3}$	1	0
4) Absolute antenna gain of the fixed measurement antenna	Systematic with Stage 2 (=> cancels)	0	R	$\sqrt{3}$	1	0
5) Measurement Receiver: uncertainty of the absolute level	Power Meter	0.06	R	$\sqrt{3}$	1	0.03
6) Chamber statistical ripple and repeatability	Statistics of chamber	0.4	N	1	1	0.4
7) Additional power loss in EUT chassis	The EUT not present in the chamber during calibration measurement	0.1	R	$\sqrt{3}$	1	0.06
8) DUT Tx-power drift	Drift	0.2	R	$\sqrt{3}$	1	0.12
9) a) Uncertainty related to the use of SAM phantom:	Standard SAM head with standard tissue simulant	0	R	$\sqrt{3}$	1	0
b) Simulated tissue liquid uncertainty	Maximum allowed error	0.5	R	$\sqrt{3}$	1	0.29
c) Effect of DUT holder	Fixed value	0.2	R	$\sqrt{3}$	1	0.12
10) Repeatability	Using the same setup and stirring sequence	0.4	R	$\sqrt{3}$	1	0.23
11) Uncertainty related to the use of Laptop Ground Plane phantom	Standard Laptop Ground Plane phantom	[0]	R	$\sqrt{3}$	1	[0]
STAGE 2 (Calibration)						
12) Uncertainty of network analyzer	Manufacturer's uncertainty calculator, covers whole NA setup	0.5	R	$\sqrt{3}$	1	0.29
13) Mismatch of receiver chain	Taken in to account in NA setup uncertainty	0	U	$\sqrt{2}$	1	0
14) Insertion loss of receiver chain	Systematic with Stage 1 (=> cancels)	0	R	$\sqrt{3}$	1	0
15) Mismatch in the connection of calibration antenna	Taken in to account in NA setup uncertainty	0	U	$\sqrt{2}$	1	0
16) Influence of the feed cable of the calibration antenna	Gain calibration with a dipole	0.3	R	$\sqrt{3}$	1	0.17
17) Influence of the fixed measurement antenna cable	Systematic with Stage 1 (=> cancels)	0	R	$\sqrt{3}$	1	0
18) Uncertainty of the absolute gain of the fixed measurement antenna	Systematic with Stage 1 (=> cancels)	0	R	$\sqrt{3}$	1	0
19) Uncertainty of the absolute gain of the calibration antenna	Calibration certificate	0.5	R	$\sqrt{3}$	1	0.29
20) Chamber statistical ripple and repeatability	Statistics of chamber	0.5	N	1	1	0.5
Combined standard uncertainty	$u_c = \sqrt{\sum_{i=1}^m c_i^2 \cdot u_i^2}$					0.88

Expanded uncertainty (Confidence interval of 95 %)			$u_e = 1,96 u_d$		1.73
---	--	--	------------------	--	------

E.30 Examples of uncertainty budget calculations for TRS, reverberation chamber method (Informative)

Table E.14: Example of uncertainty budget for TRS measurement, reverberation chamber method

Uncertainty Source	Comment	Uncertainty Value [dB]	Prob Distr	Div	ci	Standard Uncertainty [dB]
STAGE 1 (DUT measurement)						
1) Mismatch of transmitter chain	$\Gamma_{\text{BSS}} < 0.13$ $\Gamma_{\text{antenna connection}} < 0.03$	0.02	N	1	1	0.02
2) Insertion loss of transmitter chain	Systematic with Stage 1 (=> cancels)	0	R	$\sqrt{3}$	1	0
3) Influence of the fixed measurement antenna cable	Systematic with Stage 2 (=> cancels)	0	R	$\sqrt{3}$	1	0
4) Absolute antenna gain of the fixed measurement antenna	Systematic with Stage 2 (=> cancels)	0	R	$\sqrt{3}$	1	0
5) Base station simulator: uncertainty of the absolute level		1	R	$\sqrt{3}$	1	0.58
6) BER measurement: output level step resolution	Step 0.1dB	0.05	R	$\sqrt{3}$	1	0.03
7) Statistical uncertainty of the BER measurement	BER target 10%±2% , 20000 tested bits , N=60	0.12	N	1	1	0.12
8) TRS data rate normalization	4 reference points measured	0.12	N	1	1	0.12
9) Chamber statistical ripple and repeatability	Statistics of chamber	0.4	N	1	1	0.4
10) Additional power loss in EUT chassis	The EUT not present in the chamber during calibration measurement	0.1	R	$\sqrt{3}$	1	0.06
11) DUT sensitivity drift	Drift measurement	0.2	R	$\sqrt{3}$	1	0.12
12) a) Uncertainty related to the use of SAM phantom:	Standard SAM with standard tissue simulant	0	R	$\sqrt{3}$	1	0
b) Simulated tissue liquid uncertainty	Maximum allowed error	0.5	R	$\sqrt{3}$	1	0.29
c) Effect of DUT holder	Fixed value	0.2	R	$\sqrt{3}$	1	0.12
13) Repeatability	Using the same setup and stirring sequence	0.4	R	$\sqrt{3}$	1	0.23
14) Uncertainty related to the use of Laptop Ground Plane phantom	Standard Laptop Ground Plane phantom	[0]	R	$\sqrt{3}$	1	[0]
STAGE 2 (Calibration)						
15) Uncertainty of network analyzer	Manufacturer's uncertainty calculator, covers NA setup	0.5	R	$\sqrt{3}$	1	0.29
16) Mismatch of transmitter chain	Taken in to account in NA setup uncertainty	0	U	$\sqrt{2}$	1	0
17) Insertion loss of transmitter chain	Systematic with Stage 1 (=> cancels)	0	R	$\sqrt{3}$	1	0
18) Mismatch in the connection of calibration antenna	Taken in to account in NA setup uncertainty	0	R	$\sqrt{3}$	1	0
19) Influence of the feed cable of the calibration antenna	Gain calibration with dipole	0.3	R	$\sqrt{3}$	1	0.17

20) Influence of the fixed measurement antenna cable	Systematic with Stage 1 (=> cancels)	0	R	$\sqrt{3}$	1	0
21) Uncertainty of the absolute gain of the fixed measurement antenna	Systematic with Stage 1 (=> cancels)	0	R	$\sqrt{3}$	1	0
22) Uncertainty of the absolute gain of the calibration antenna	Calibration certificate	0.5	R	$\sqrt{3}$	1	0.29
23) Chamber statistical ripple and repeatability	Statistics of chamber	0.5	N	1	1	0.5
Combined standard uncertainty	$u_c = \sqrt{\sum_{i=1}^m c_i^2 \cdot u_i^2}$					1.07
Expanded uncertainty (Confidence interval of 95 %)			$u_e = 1,96 u_c$			2.09

Annex F (informative): Suggested Recipes of Liquid to be used inside SAM Phantom

In Tables F.1 – F.2 are proposed two different recipes of the liquid to be used inside the SAM phantom.

Table F.1: Liquid recipe

Component	Mass %
De-ionized Water	57.12
Tween 20	42.30
NaCl	0.58

Table F.2: Liquid recipe

Component	Mass %
De-ionized Water	54.9 %
Diethylene Glycol Butyl Ether (DGBE) (> 99 % pure)	44.92 %
NaCl	0.18 %

Annex G (informative): Anechoic Chamber Specifications and Validation Method

This Appendix presents the specifications for the shielded anechoic chamber and the validation methods.

G.1 Shielded anechoic chamber specifications

To avoid environmental perturbations the measurements shall be performed in a shielded enclosure, preserved from electromagnetic disturbances coming from electromagnetic environment (Radio and TV broadcast, cellular, ISM equipment, etc...). The shielding effectiveness shall be tested according to the EN 50 147-1 standard in the frequency range of 800 MHz up to 4 GHz.

The recommended level of the shielding effectiveness is -100 dB from 800 MHz to 4 GHz.

Testing of the shielding effectiveness can be performed either before or after the installation of absorbers.

G.2 Quiet Zone reflectivity level validation

The performance of anechoic chamber is typically evaluated from reflectivity level R_{level} in the quiet zone. Reflectivity level is defined as power ratio of all summed reflected signals P_r to direct signal P_d from antenna:

$$R_{level} = 10 \log \frac{P_r}{P_d} .$$

To evaluate the quiet zone reflectivity level, the contribution of absorbing materials, the antenna positioning system and other constructions in the anechoic chamber should be measured.

To measure accurately quality of the quiet zone in anechoic chamber an omni-directional antenna shall be used. Near omni-directional three axes field-probes are available with fibre optic connection thus minimizing cable effects. Because sensitivity of field probe is limited it shall be carefully checked that the field probe is operated at least 6dB above the noise floor of the probe.

NOTE: The quiet zone evaluation should be performed with the antenna positioning system in its place, in order to include its effect on the reflectivity level.

G.2.1 Description of a practical method for Quiet Zone characterization

In the following, a practical version of the Free Space VSWR method is presented.

In the Free Space VSWR method the quality of quiet zone is measured from amplitude ripple caused by reflections inside the anechoic chamber. Phase variation of the direct signal and the reflected signals is obtained by moving a field-probe in the quiet zone. Amplitude ripple in the quiet zone is caused by this phase variation of reflected signals and the direct signal from antenna. The figure 2 below shows seven measuring positions.

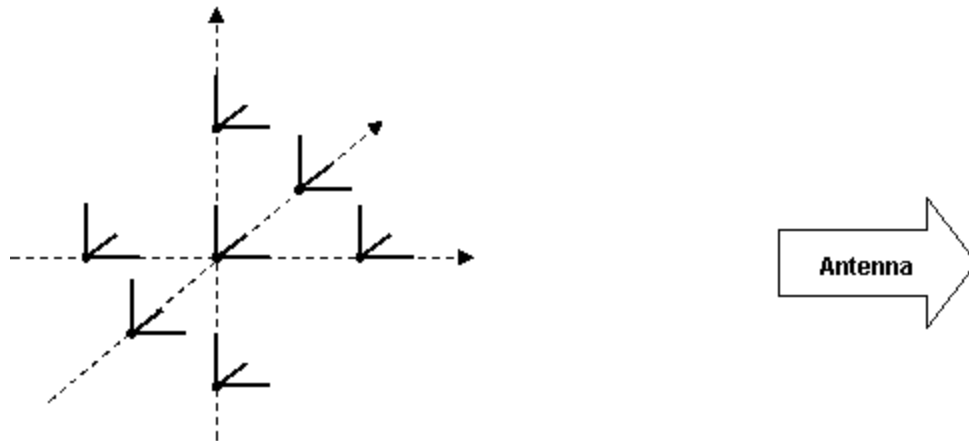

Figure G.2: Measurement positions with 150mm separation

In each of the seven-measurement position amplitude of power received by field-probe P_{meas_n} [dBm] is measured where n is index of measuring position. Variance of measurement distance to the antenna from field-probe in different measurement positions can be compensated by following equation:

$$P_n = P_{meas_n} + 20 \log\left(\frac{d_n}{l}\right)$$

where,

d_n is distance to point n from the antenna,

l is distance to centre of quiet zone from the antenna

P_{meas_n} is uncorrected measurement value from point n .

The sample standard deviation of the electric field in the quiet zone can be calculated from these distance corrected values or directly from the measured values with the following equation:

$$s = \sqrt{\frac{1}{N-1} \sum_{i=1}^N (P_i - \bar{P})^2}$$

where,

N is number of measurements positions

\bar{P} is dB average of all P_n

P_i is P_n or P_{meas_n}

G.3 FFS

G.4 Standard deviation of electric field

To obtain more accurate picture of quality of quiet zone, measurement described in previous chapter can be done from multiple directions and polarizations. Doing free space VSWR measurement from different directions in 15-degree

separation for elevation and azimuth we get 264 standard deviation values in both polarizations ($S_{\theta,\Phi,pol}$). From these values average sample standard deviation in electric field in quiet zone can be calculated from equation:

$$\overline{S}_{freq} = \frac{\frac{\pi}{2IJ} \sum_{i=1}^I \sum_{j=1}^J S_{i,j,hor} \sin(\Theta_i) + \frac{\pi}{2IJ} \sum_{i=1}^I \sum_{j=1}^J S_{i,j,ver} \sin(\Theta_i)}{2}$$

where,

I is number of angular intervals in elevation,

J is number of angular intervals in azimuth and

Θ_i is elevation of measurement $S_{i,j,pol}$.

This quiet zone quality measurement should be done at all the frequencies used in measurements, but can be sufficient on all the centre frequencies in the measurement bands but also in this case the Tx and Rx shall be measured separately.

Annex G.A (informative): Reverberation Chamber Specifications and Validation Method

This Annex presents the specifications for the shielded reverberation chamber and the validation methods.

G.A.1 Shielded reverberation chamber specifications

Before measuring the test site characteristics in terms of stirring effectiveness etc., the shielding effectiveness of the metallic enclosure must be measured.

To avoid environmental perturbations the measurements must be performed in a shielded enclosure, preserved from electromagnetic disturbances coming from electromagnetic environment (Radio and TV broadcast, cellular, ISM equipment, etc...). The shielding effectiveness recommended to be tested according to the EN 50 147-1 standard in the frequency range of 800 MHz up to 4 GHz.

The recommended level of the shielding effectiveness is -100 dB from 800 MHz to 4 GHz.

G.A.2 Reverberation chamber statistical ripple and repeatability validation

The reverberation chamber is typically evaluated according to its isotropy level and ability to produce independent samples. The uncertainty due to chamber statistics is determined by repeated calibration measurements as described in Annex B.2. This uncertainty contribution is a composite value consisting of most of the specific reverberation chamber contributions, such as limited number of modes, polarization imbalance and mode-stirring techniques.

The uncertainty contribution value shall be determined by repeated calibration measurements for nine different positions and orientations of the calibration antenna in order to determine the statistical variation as a function of frequency, or at least at the frequencies where the chamber shall be used. This uncertainty contribution value can be assumed to have a normal distribution.

The uncertainty will depend on chamber size, frequency, stirrer sequence, stirrer types and shapes, polarization stirring (if any), and the degree of chamber loading. All these factors must remain the same for all nine calibration measurements. The uncertainty will also depend on frequency stirring bandwidth (if any), but the effects of different

amounts of frequency stirring can be studied with the same sets of calibration data as when no frequency stirring is applied.

The nine net average power transfer functions of all or some of the nine calibration configurations for each loading case shall be averaged to provide a good reference level. Frequency stirring can only be applied to improve the reference level. Therefore, the uncertainty shall be found by computing the average and standard deviation of the net average power transfer function of each of the nine reference (antenna) positions and orientations (without frequency stirring) around the reference level (which can be frequency stirred if it gives better overall accuracy).

The data obtained during these reference measurements can be used for analysis of the chamber's systematic and deterministic contribution to S21. Such analysis can help determine possible uncertainty sources in chambers where the "chamber statistics" portion of the uncertainty analysis is too high to fulfil the total uncertainty criterion. The normalized standard deviation is calculated using the following expression:

$$\Sigma_{measured} = \frac{\sqrt{\sigma^2}}{P_{ref}^{mean}}$$

where

$$\sigma^2 = \frac{1}{T} \sum_{t=1}^T (P_{ref,t} - P_{ref}^{mean})^2$$

is the standard deviation of the power transfer function over T different calibration antenna positions. $P_{ref,t}$ is the reference power transfer function for position t of the calibration antenna. The power transfer function for every calibration antenna position is further the average over the power transfer function $P_{ref,t,n}$ for each fixed measurement antenna in the chamber defined in Annex B.2. Thus,

$$P_{ref,t} = \frac{1}{N} \sum_{n=1}^N P_{ref,t,n}$$

where N is the total number of fixed measurement antennas. Moreover,

$$P_{ref}^{mean} = \frac{1}{T} \sum_{t=1}^T P_{ref,t}$$

is the average power transfer function over the T calibration antenna positions.

Annex H (informative): Recommended performance

H.1 General

This annex introduces the concept of recommended OTA performance for operating bands. This requirement is not mandatory but is recommended.

The concept of recommended performance is to ensure that UE/MS OTA performance is maximised in order to improve user experience and network performance. It is recognised that the ability to meet the recommended performance depends on the number of frequency bands supported by the UE/MS.

H.2 Total Radiated Power

The OTA performance for FDD and GSM should be greater or equal than the recommended values shown in Tables H.1, H.1A, H.1B, H.2, H.2A, H.2B, H.2C H.2D, and H.2E, respectively.

Table H.1: TRP recommended performance for FDD in the speech position and the primary mechanical mode

Operating band	Power Class 1	Power Class 2	Power Class 3	Power Class 3bis	Power Class 4
	Power (dBm)	Power (dBm)	Power (dBm)	Power (dBm)	Power (dBm)
			Average	Average	Average
I	-	-	+17.3	+17.3	+15.3
II	-	-	+17.3	+17.3	+15.3
III	-	-	+17.3	+17.3	+15.3
IV	-	-	+17.3	+17.3	+15.3
V	-	-	+13.3	+13.3	+11.3
VI	-	-	+13.8	+13.8	+11.8
VII	-	-	+17.3	+17.3	+15.3
VIII	-	-	+14.3	+14.3	+12.3
IX	-	-	+17.3	+17.3	+15.3

NOTE: Applicable for dual-mode GSM/UMTS.

NOTE: The Test Tolerance applied for this test is non-zero. The Test Tolerance for this test is defined and explained in Annex D.

Table H.1A: TRP recommended performance for FDD LME devices in data transfer position

Operating band	Power Class 1	Power Class 2	Power Class 3	Power Class 3bis	Power Class 4
	Power (dBm)	Power (dBm)	Power (dBm)	Power (dBm)	Power (dBm)
			Average	Average	Average
I	-	-	TBD + TT	TBD + TT	TBD + TT
II	-	-	TBD + TT	TBD + TT	TBD + TT
III	-	-	TBD + TT	TBD + TT	TBD + TT
IV	-	-	TBD + TT	TBD + TT	TBD + TT
V	-	-	TBD + TT	TBD + TT	TBD + TT
VI	-	-	TBD + TT	TBD + TT	TBD + TT
VII	-	-	TBD + TT	TBD + TT	TBD + TT
VIII	-	-	TBD + TT	TBD + TT	TBD + TT
IX	-	-	TBD + TT	TBD + TT	TBD + TT

NOTE 1: Applicable for dual-mode GSM/UMTS.
NOTE 2: Applicable for USB plug-in devices.

NOTE: The Test Tolerance applied for this test is non-zero. The Test Tolerance for this test is defined and explained in Annex D.

Table H.1B: TRP recommended performance for FDD LEE devices in data transfer position

Operating band	Power Class 1	Power Class 2	Power Class 3	Power Class 3bis	Power Class 4
	Power (dBm)	Power (dBm)	Power (dBm)	Power (dBm)	Power (dBm)
			Average	Average	Average
I	-	-	TBD + TT	TBD + TT	TBD + TT
II	-	-	TBD + TT	TBD + TT	TBD + TT
III	-	-	TBD + TT	TBD + TT	TBD + TT
IV	-	-	TBD + TT	TBD + TT	TBD + TT
V	-	-	TBD + TT	TBD + TT	TBD + TT
VI	-	-	TBD + TT	TBD + TT	TBD + TT
VII	-	-	TBD + TT	TBD + TT	TBD + TT
VIII	-	-	TBD + TT	TBD + TT	TBD + TT
IX	-	-	TBD + TT	TBD + TT	TBD + TT

NOTE 1: Applicable for dual-mode GSM/UMTS.
NOTE 2: Applicable for notebook devices.

NOTE: The Test Tolerance applied for this test is non-zero. The Test Tolerance for this test is defined and explained in Annex D.

Table H.2: TRP recommended performance for GSM in the speech position and the primary mechanical mode

Operating band	Power Class 1	Power Class 2	Power Class 3	Power Class 4	Power Class 5
	Power (dBm)	Power (dBm)	Power (dBm)	Power (dBm)	Power (dBm)
	Average	Average	Average	Average	Average
GSM 850				+23.3	
P-GSM 900				+23.3	
E-GSM 900				+23.3	
DCS 1800	+23.3				
PCS 1900	+23.3				

NOTE: Applicable for dual-mode GSM/UMTS.

NOTE: The Test Tolerance applied for this test is non-zero. The Test Tolerance for this test is defined and explained in Annex D.

Table H.2A: TRP recommended performance for GSM LME devices in data transfer position

Operating band	Power Class 1	Power Class 2	Power Class 3	Power Class 4	Power Class 5
	Power (dBm)	Power (dBm)	Power (dBm)	Power (dBm)	Power (dBm)
	Average	Average	Average	Average	Average
GSM 850	-	-	-	TBD + TT	-
GSM 900	-	-	-	TBD + TT	-
DCS 1800	TBD + TT	-	-	-	-
PCS 1900	TBD + TT	-	-	-	-

NOTE 1: Applicable for dual-mode GSM/UMTS.
NOTE 2: Applicable for USB plug-in devices.

NOTE: The Test Tolerance applied for this test is non-zero. The Test Tolerance for this test is defined and explained in Annex D.

Table H.2B: TRP recommended performance for GSM LEE devices in data transfer position

Operating band	Power Class 1	Power Class 2	Power Class 3	Power Class 4	Power Class 5
	Power (dBm)	Power (dBm)	Power (dBm)	Power (dBm)	Power (dBm)
	Average	Average	Average	Average	Average
GSM 850	-	-	-	TBD + TT	-
GSM 900	-	-	-	TBD + TT	-
DCS 1800	TBD + TT	-	-	-	-
PCS 1900	TBD + TT	-	-	-	-

NOTE 1: Applicable for dual-mode GSM/UMTS.
NOTE 2: Applicable for notebook devices.

NOTE: The Test Tolerance applied for this test is non-zero. The Test Tolerance for this test is defined and explained in Annex D.

Table H.2C: TRP recommended performance for TDD in the speech position and the primary mechanical mode

Operating band	Power Class 1	Power Class 2	Power Class 3	Power Class 3bis	Power Class 4
	Power (dBm)	Power (dBm)	Power (dBm)	Power (dBm)	Power (dBm)
	Average	Average	Average	Average	Average
a	-	+17.3	-	-	-
b	-	TBD + TT	-	-	-
c	-	TBD + TT	-	-	-
d	-	TBD + TT	-	-	-
e	-	+17.3	-	-	-
f	-	+17.3	-	-	-

NOTE: Applicable for dual-mode GSM/UTRA/LCR TDD.

NOTE: The Test Tolerance applied for this test is non-zero. The Test Tolerance for this test is defined and explained in Annex D.

Table H.2D: TRP recommended performance for TDD LME devices in data transfer position

Operating band	Power Class 1	Power Class 2	Power Class 3	Power Class 3bis	Power Class 4
	Power (dBm)	Power (dBm)	Power (dBm)	Power (dBm)	Power (dBm)
	Average	Average	Average	Average	Average
a	-	TBD + TT	-	-	-
b	-	TBD + TT	-	-	-
c	-	TBD + TT	-	-	-
d	-	TBD + TT	-	-	-
e	-	TBD + TT	-	-	-
f	-	TBD + TT	-	-	-

NOTE 1: Applicable for dual-mode GSM/UTRA/LCR TDD.
NOTE 2: Applicable for USB plug-in devices.

NOTE: The Test Tolerance applied for this test is non-zero. The Test Tolerance for this test is defined and explained in Annex D.

Table H.2E: TRP recommended performance for TDD LEE devices in data transfer position

Operating band	Power Class 1	Power Class 2	Power Class 3	Power Class 3bis	Power Class 4
	Power (dBm)	Power (dBm)	Power (dBm)	Power (dBm)	Power (dBm)
	Average	Average	Average	Average	Average
a	-	TBD + TT	-	-	-
b	-	TBD + TT	-	-	-
c	-	TBD + TT	-	-	-
d	-	TBD + TT	-	-	-
e	-	TBD + TT	-	-	-
f	-	TBD + TT	-	-	-

NOTE 1: Applicable for dual-mode GSM/UTRA/LCR TDD.
NOTE 2: Applicable for notebook devices.

NOTE: The Test Tolerance applied for this test is non-zero. The Test Tolerance for this test is defined and explained in Annex D.

H.3 Total Radiated Sensitivity

The OTA performance for FDD and GSM should be lesser or equal than the recommended values shown in Tables H.3, H.3A, H.3B, H.4, H.4A, H.4B, H.5, H.5A, and H.5B, respectively.

Table H.3: TRS recommended performance for FDD in the speech position for the primary mechanical mode

Operating Band	Unit	<REF _{or} > Average
I	dBm/3.84 MHz	-103.1
II	dBm/3.84 MHz	-101.1
III	dBm/3.84 MHz	-100.1
IV	dBm/3.84 MHz	-103.1
V	dBm/3.84 MHz	-98.6
VI	dBm/3.84 MHz	-100.1
VII	dBm/3.84 MHz	-101.1
VIII	dBm/3.84 MHz	-99.1
IX	dBm/3.84 MHz	-102.1

NOTE: Applicable for dual-mode GSM/UMTS.

NOTE: The Test Tolerance applied for this test is non-zero. The Test Tolerance for this test is defined and explained in Annex D.

Table H.3A: TRS recommended performance for FDD LME devices in the data transfer position

Operating Band	Unit	<REF _{or} > Average
I	dBm/3.84 MHz	TBD + TT
II	dBm/3.84 MHz	TBD + TT
III	dBm/3.84 MHz	TBD + TT
IV	dBm/3.84 MHz	TBD + TT
V	dBm/3.84 MHz	TBD + TT
VI	dBm/3.84 MHz	TBD + TT
VII	dBm/3.84 MHz	TBD + TT
VIII	dBm/3.84 MHz	TBD + TT
IX	dBm/3.84 MHz	TBD + TT

NOTE 1: Applicable for dual-mode GSM/UMTS.
NOTE 2: Applicable for USB plug-in devices.

NOTE: The Test Tolerance applied for this test is non-zero. The Test Tolerance for this test is defined and explained in Annex D.

Table H.3B: TRS recommended performance for FDD LEE devices in the data transfer position

Operating Band	Unit	<REF _{or} > Average
I	dBm/3.84 MHz	TBD + TT
II	dBm/3.84 MHz	TBD + TT
III	dBm/3.84 MHz	TBD + TT
IV	dBm/3.84 MHz	TBD + TT
V	dBm/3.84 MHz	TBD + TT
VI	dBm/3.84 MHz	TBD + TT
VII	dBm/3.84 MHz	TBD + TT
VIII	dBm/3.84 MHz	TBD + TT
IX	dBm/3.84 MHz	TBD + TT

NOTE 1: Applicable for dual-mode GSM/UMTS.
NOTE 2: Applicable for notebook devices.

NOTE: The Test Tolerance applied for this test is non-zero. The Test Tolerance for this test is defined and explained in Annex D.

Table H.4: TRS recommended performance for GSM in the speech position and the primary mechanical mode

Operating Band	Unit	<REF _{or} > Average
GSM 850	dBm	-99.6
P-GSM 900	dBm	-99.6
E-GSM 900	dBm	-99.6
DCS 1800	dBm	-102.6
PCS 1900	dBm	-102.6

NOTE: Applicable for dual-mode GSM/UMTS.

NOTE: The Test Tolerance applied for this test is non-zero. The Test Tolerance for this test is defined and explained in Annex D.

Table H.4A: TRS recommended performance for GSM LME devices in the data transfer position

Operating Band	Unit	<REF _{or} > Average
GSM 850	dBm	TBD + TT
GSM 900	dBm	TBD + TT
DCS 1800	dBm	TBD + TT
PCS 1900	dBm	TBD + TT

NOTE 1: Applicable for dual-mode GSM/UMTS.
NOTE 2: Applicable for USB plug-in devices.

NOTE: The Test Tolerance applied for this test is non-zero. The Test Tolerance for this test is defined and explained in Annex D.

Table H.4B: TRS recommended performance for GSM LEE devices in the data transfer position

Operating Band	Unit	<REF _{or} > Average
GSM 850	dBm	TBD + TT
GSM 900	dBm	TBD + TT
DCS 1800	dBm	TBD + TT
PCS 1900	dBm	TBD + TT

NOTE 1: Applicable for dual-mode GSM/UMTS.
NOTE 2: Applicable for notebook devices.

NOTE: The Test Tolerance applied for this test is non-zero. The Test Tolerance for this test is defined and explained in Annex D.

Table H.5: TRS recommended performance for TDD in the speech position and the primary mechanical mode

Operating Band	Unit	<REF _{or} > Average
-	-	-
a	dBm/1.28 MHz	-104.1
b	dBm/1.28 MHz	TBD + TT
c	dBm/1.28 MHz	TBD + TT
d	dBm/1.28 MHz	TBD + TT
e	dBm/1.28 MHz	-104.1
f	dBm/1.28 MHz	-104.1

NOTE: Applicable for dual-mode GSM/UTRA LCR TDD.

NOTE: The Test Tolerance applied for this test is non-zero. The Test Tolerance for this test is defined and explained in Annex D.

Table H.5A: TRS recommended performance for TDD LME devices in the data transfer position

Operating Band	Unit	<REFlor>
-	-	Average
a	dBm/1.28 MHz	TBD
b	dBm/1.28 MHz	TBD
c	dBm/1.28 MHz	TBD
d	dBm/1.28 MHz	TBD
e	dBm/1.28 MHz	TBD
f	dBm/1.28 MHz	TBD
NOTE 1: Applicable for dual-mode GSM/UTRA LCR TDD.		
NOTE 2: Applicable for notebook devices.		

NOTE: The Test Tolerance applied for this test is non-zero. The Test Tolerance for this test is defined and explained in Annex D.

Table H.5B: TRS recommended performance for TDD LEE devices in the data transfer position

Operating Band	Unit	<REFlor>
-	-	Average
a	dBm/1.28 MHz	TBD
b	dBm/1.28 MHz	TBD
c	dBm/1.28 MHz	TBD
d	dBm/1.28 MHz	TBD
e	dBm/1.28 MHz	TBD
f	dBm/1.28 MHz	TBD
NOTE 1: Applicable for dual-mode GSM/UTRA LCR TDD.		
NOTE 2: Applicable for notebook devices.		

NOTE: The Test Tolerance applied for this test is non-zero. The Test Tolerance for this test is defined and explained in Annex D.

Annex I (informative): Bibliography

- P. Boutou, J. Krogerus, J. Ø. Nielsen, T. Bolin, I. Egorov, K. Sulonen, "Measurement of Radio Performances for UMTS Mobile in Speech Mode: the First Draft of the Prestandard", COST 273 TD(03) 140, Paris, France, May 2003, 6 p.
- "Feasibility Study of UE antenna efficiency test methods and performance requirement-final report", 3GPP TSG-RAN4 document TSGR#19(01)1086, September 2001.
- L. M. Correia (editor), "Wireless Flexible Personalised Communications – Final Report of COST 259", ISBN: 0-471-49836-X, Wiley Europe, March 2001, 482 p.
- "Development of Standard Test Procedure for 3G User Equipment Antenna Performance", 3GPP TSG-RAN Working Group 4 (Radio) meeting #23, R4-020724, Gyeongju, Korea, 13th -17th May, 2002.
- IEEE standard 1528; "Recommended Practice for Determining the Peak Spatial-Average Specific Absorption Rate (SAR) in the Human Head from Wireless Communications Devices: Experimental Techniques", December, 2003.
- M. Y. Kanda, M. Ballen, C.K. Chou. "Formulation and characterization of tissue simulating liquids used for SAR measurement (500-2000 MHz)" Asia-Pacific Radio Science Conference, Tokyo, Japan, August 1-4, 2001, p. 274.
- V. Vigneras, "Elaboration and characterization of biological tissues equivalent liquids in the frequency range 0.9-3 GHz", Final report, PIOM Laboratory, University of Bordeaux, France, November 2001.

- E. Van Lil, D. Trappeniers, J. Verhaevert, A. Van de Capelle, "On the influence of the size of objects on the number of power pattern samples and harmonics", COST273 TD(04)051.
- J. Krogerus, T. Jääskö, C. Icheln, "Comparison Measurements of the COST 273 SW G 2.2 Reference Monopole Antennas", COST273 TD(03)131.
- L. Foged, A. Gandois et. al. "Reference antennas", Draft report for COST273 SW G2.2 (unpublished), 12.10.2004.
- H. Shapter, J. Krogerus, "Uncertainty in Total Radiated Power measurements", Presentation in COST273 SW G2.2 Meeting, Helsinki, May 2002, 9 p. + Appendix 9 p., (unpublished).
- J. Krogerus, A. Krüy, H. Shapter, S. Pannetrat, B. Derat, "Estimation of Measurement Uncertainty in Total Radiated Power Measurements", COST 273 TD(04) 128, Gothenburg, June 2004, 23 p.
- "Guide to the Expression of Uncertainty in Measurement", International Organization for Standardization (ISO), Geneva, Switzerland 1995.
- NIST Technical Note 1297: "Guidelines for Evaluating and Expressing the Uncertainty of NIST measurement Results"
- IEC: "Guide to the expression of uncertainty in measurement", Ed 1:1995.
- "American National Standard for Expressing Uncertainty - U.S. Guide to the Expression of Uncertainty in Measurement," ANSI/NCSL Z540-2-1997, American National Standards Institute, New York, NY, 1997.
- J. Krogerus, "On the phantom and tissue simulating liquid to be used in handset antenna performance testing", COST 273 TD(02) 024, Guildford, UK, January 2002.
- J. Krogerus, "Phantoms for Terminal Antenna Performance Testing", COST 273 TD(02) 154, Lisbon, Portugal, September 2002, 14 p.
- H. Knoess, M. Christensen, S. Svendsen, T. Hiegler, A. Friederich, "Investigation of Different Phantom Head Models Including Holder", COST 273 TD(04) 068, Gothenburg, June 2004, 6 p.
- Alayon Glazunov, "Impact of Head Phantom Models on Handset Antenna Efficiency Measurement Accuracy in Terms of Body Loss in Passive Mode", COST273 TD(02)144.
- K. Sulonen, K. Kalliola, P. Vainikainen, "The effect of angular power distribution in different environments and the angular resolution of radiation pattern measurement on antenna performance", COST 273 TD(02) 028, Guildford, UK, January 2002, 7 p.

Annex J (informative): Change history

Meeting-1st-Level	Doc-1st-Level	CR	Rev	Subject	Cat	Version-Current	Version-New	Doc-2nd-Level
RP-37	RP-070665	-	-	TS 34.114 for information	-	-	1.0.0	R5-072420
RP-41	RP-080612	-	-	New version of 34.114	-	1.0.0	7.0.0	R5-083817
RP-43	RP-090203	0001	-	Update of TS 34.114 from Rel-7 to Rel-8	-	7.0.0	8.0.0	R5-090761
RP-43	RP-090203	0002	-	Addition of Band V,VI and VIII minimum & test requirements to 34.114	-	8.0.0	8.1.0	R5-090412
RP-45	RP-090813	0003	-	TDD UE over the Air conformance testing methodology	-	8.1.0	8.2.0	R5-094961
RP-46	RP-091119	0004	-	Over The Air antenna performance: New informative Annex for Recommended performance	-	8.2.0	8.3.0	R5-096254
RP-47	-	-	-	Moved to v9.0.0 with no change	-	8.3.0	9.0.0	-
RP-51	RP-110166	0005	-	OTA FDD Band 4 and 5 Mid Test Channel Change	F	9.0.0	9.1.0	R5-110530
RP-51	RP-110166	0006	-	CR to 34.114 : Addition of the GSM OTA requirements and recommended values	F	9.0.0	9.1.0	R5-110926
RP-53	RP-111157	0007	-	Update on abbreviation list in section 3.2	F	9.1.0	9.2.0	R5-113442
RP-53	RP-111157	0008	-	Addition of Scope to include Laptop Equipment Free Space	F	9.2.0	10.0.0	R5-114067
RP-53	RP-111157	0009	-	Addition of DUT positioning for Laptop Equipment Free Space transmitter	F	9.2.0	10.0.0	R5-114068
RP-53	RP-111157	0010	-	Addition of DUT positioning for Laptop Equipment Free Space receiver performance	F	9.2.0	10.0.0	R5-114069
RP-54	RP-111636	0012	-	Introduction of alternative measurement procedure in TS 34.114	F	10.0.0	10.1.0	R5-115890
RP-54	RP-111636	0012	-	Added missing changes of R5-115890 from Annex B onwards.	F	10.1.0	10.1.1	R5-115890
RP-55	RP-120184	0013	-	Correction to TRP and TRS Tests	F	10.1.1	10.2.0	R5-120429
RP-55	RP-120204	0014	-	Corrections to Abbreviations for Laptop Equipment Free Space	F	10.2.0	11.0.0	R5-120468
RP-55	RP-120204	0015	-	Introduction of LME & LEE for Measurement Test Report	F	10.2.0	11.0.0	R5-120477
RP-55	RP-120204	0016	-	Introduction of Maximum Uncertainty of Test System and TT for LME	F	10.2.0	11.0.0	R5-120478
RP-55	RP-120204	0017	-	Introduction of Recommended OTA Performance for Operating Bands for LME & LEE	F	10.2.0	11.0.0	R5-120479
RP-55	RP-120204	0018	-	Introduction of Tx Performance of TRP for LME FDD	F	10.2.0	11.0.0	R5-120865
RP-55	RP-120204	0019	-	Introduction of Tx Performance of TRP for LME TDD	F	10.2.0	11.0.0	R5-120866
RP-55	RP-120204	0020	-	Introduction of Rx Performance of TRS for LME FDD	F	10.2.0	11.0.0	R5-120867
RP-55	RP-120204	0021	-	Introduction of Rx Performance of TRS for LME TDD	F	10.2.0	11.0.0	R5-120868
RP-55	RP-120204	0022	-	Introduction for Characteristics of the Laptop Ground Plane Phantom Specification	F	10.2.0	11.0.0	R5-120869
RP-55	RP-120204	0023	-	Introduction of LME & LEE for Calibration Procedure	F	10.2.0	11.0.0	R5-120870
RP-55	RP-120204	0024	-	Corrections to DUT positioning for Laptop Equipment Free Space Performance	F	10.2.0	11.0.0	R5-120871
RP-55	RP-120204	0025	-	CR for new FDD OTA Test cases 5.6, 5.8, 5.9, 6.6, 6.8 & 6.9 for LME and LEE devices	F	10.2.0	11.0.0	R5-120872
RP-55	RP-120204	0026	-	Corrections to Scope related to Laptop Equipment Free Space	F	10.2.0	11.0.0	R5-120873
RP-56	RP-120668	0028	-	Corrections to Scope related to Laptop Equipment Free Space Definition	F	11.0.0	11.1.0	R5-121342
RP-56	RP-120668	0029	-	Additional Clarifications to DUT positioning for Laptop Equipment Free Space Performance	F	11.0.0	11.1.0	R5-121343
RP-56	RP-120668	0030	-	Corrections to Tx Performance of TRP for LME GSM	F	11.0.0	11.1.0	R5-121345
RP-56	RP-120668	0031	-	Corrections to Tx Performance of TRP for LME TDD	F	11.0.0	11.1.0	R5-121346
RP-56	RP-120668	0032	-	Corrections to Tx Performance of TRP for LEE GSM	F	11.0.0	11.1.0	R5-121347
RP-56	RP-120668	0033	-	Introduction of Tx Performance of TRP for LEE TDD	F	11.0.0	11.1.0	R5-121348
RP-56	RP-120668	0034	-	Corrections to Rx Performance of TRS for LME FDD	F	11.0.0	11.1.0	R5-121349
RP-56	RP-120668	0035	-	Clarifications to TRS Requirements for Roaming Bands for conformance testing	F	11.0.0	11.1.0	R5-121362
RP-56	RP-120668	0036	-	Introduction of Embedded Devices Characteristics	F	11.0.0	11.1.0	R5-121363
RP-56	RP-120668	0037	-	Clarifications to LME & LEE for Calibration Procedure	F	11.0.0	11.1.0	R5-121368
RP-56	RP-120668	0038	-	Clarifications to LME & LEE for Measurement Test Report	F	11.0.0	11.1.0	R5-121372
RP-56	RP-120668	0039	-	Clarifications to Maximum Uncertainty of Test System and TT for LME	F	11.0.0	11.1.0	R5-121373

Meeting-1st-Level	Doc-1st-Level	CR	Rev	Subject	Cat	Version-Current	Version-New	Doc-2nd-Level
RP-56	RP-120668	0040	-	Clarifications to Recommended OTA Performance for Operating Bands for LME & LEE	F	11.0.0	11.1.0	R5-121374
RP-56	RP-120668	0041	-	Clarification to TRP and TRS Requirements for Band (XIX)	F	11.0.0	11.1.0	R5-121375
RP-56	RP-120668	0042	-	Clarifications to Statistical Uncertainty of the BER measurement for GSM	F	11.0.0	11.1.0	R5-121376
RP-56	RP-120668	0043	-	Corrections to Tx Performance of TRP for LME FDD	F	11.0.0	11.1.0	R5-121912
RP-56	RP-120668	0044	-	Corrections to Rx Performance of TRS for LME GSM	F	11.0.0	11.1.0	R5-121913
RP-56	RP-120668	0045	-	Corrections to Rx Performance of TRS for LEE GSM	F	11.0.0	11.1.0	R5-121914
RP-56	RP-120668	0046	-	Corrections to Rx Performance of TRS for LME TDD	F	11.0.0	11.1.0	R5-121978
RP-56	RP-120668	0047	-	Introduction of Rx Performance of TRS for LEE TDD	F	11.0.0	11.1.0	R5-121979
RP-57	RP-121121	0048	-	Clarifications to User Equipment (UE) and Mobile State (MS) over the air performance requirements	F	11.1.0	11.2.0	R5-123140
RP-57	RP-121121	0049	-	Corrections to recommended OTA performance for operating bands	F	11.1.0	11.2.0	R5-123141
RP-57	RP-121121	0050	-	Introduction of Estimation of Measurement Uncertainty for LME & LEE	F	11.1.0	11.2.0	R5-123965
RP-57	RP-121121	0051	-	Clarifications to examples of uncertainty budget calculations for LME & LEE	F	11.1.0	11.2.0	R5-123966
RP-58	RP-121687	0052	-	Corrections to Uncertainty related to the use of Phantoms	F	11.2.0	11.3.0	R5-125411
RP-58	RP-121687	0053	-	Corrections to Random Uncertainty	F	11.2.0	11.3.0	R5-125412
RP-58	RP-121687	0054	-	Corrections to Scope related to UEs and laptops using the SISO/SIMO mode	F	11.2.0	11.3.0	R5-125414
RP-58	RP-121687	0055	-	Clarifications to Receiver Performance for SIMO mode	F	11.2.0	11.3.0	R5-125415
RP-58	RP-121687	0056	-	Modification to Uncertainty contributions for LME & LEE	F	11.2.0	11.3.0	R5-125838
RP-58	RP-121687	0057	-	Corrections to examples of uncertainty budget calculations	F	11.2.0	11.3.0	R5-125839