

3GPP TS 32.615 V9.2.0 (2010-12)

Technical Specification

**3rd Generation Partnership Project;
Technical Specification Group Services and System Aspects;
Telecommunication management;
Configuration Management (CM);
Bulk CM Integration Reference Point (IRP):
eXtensible Markup Language (XML) file format definition
(Release 9)**



The present document has been developed within the 3rd Generation Partnership Project (3GPPTM) and may be further elaborated for the purposes of 3GPP. The present document has not been subject to any approval process by the 3GPP Organizational Partners and shall not be implemented. This Specification is provided for future development work within 3GPP only. The Organizational Partners accept no liability for any use of this Specification. Specifications and reports for implementation of the 3GPPTM system should be obtained via the 3GPP Organizational Partners' Publications Offices.

Keywords

GSM, UMTS, management

3GPP

Postal address

3GPP support office address

650 Route des Lucioles - Sophia Antipolis
Valbonne - FRANCE
Tel.: +33 4 92 94 42 00 Fax: +33 4 93 65 47 16

Internet

<http://www.3gpp.org>

Copyright Notification

No part may be reproduced except as authorized by written permission.
The copyright and the foregoing restriction extend to reproduction in all media.

© 2010, 3GPP Organizational Partners (ARIB, ATIS, CCSA, ETSI, TTA, TTC).
All rights reserved.

UMTS™ is a Trade Mark of ETSI registered for the benefit of its members
3GPP™ is a Trade Mark of ETSI registered for the benefit of its Members and of the 3GPP Organizational Partners
LTE™ is a Trade Mark of ETSI currently being registered for the benefit of its Members and of the 3GPP Organizational Partners
GSM® and the GSM logo are registered and owned by the GSM Association

Contents

Foreword	4
Introduction	4
1 Scope	5
2 References.....	5
3 Definitions and abbreviations	6
3.1 Definitions	6
3.2 Abbreviations.....	7
4 Structure and content of configuration data XML files.....	8
4.1 Global structure.....	8
4.2 XMLelements fileHeader and fileFooter	10
4.2.1 XMLelement fileHeader	10
4.2.2 XMLelement fileFooter	10
4.3 XMLelement configData	12
4.3A NRM-specific XML elements	13
4.3A.1 NRM-specific XML schemas	13
4.3A.2 Generic mapping rules.....	13
4.4 XML attribute specification modifier	16
4.5 XMLelements VsDataContainer, vsData and vsDataFormatVersion.....	20
5 Structure and content of session log XML files	21
5.1 Global structure.....	21
5.2 XMLelements fileHeader and fileFooter	22
5.3 XMLelement activity.....	22
6 BulkCMIRP Notification XML Definitions	24
Annex A (normative): Configuration data file base XML schema (file name "configData.xsd").....	25
Annex B (normative): Void.....	28
Annex C (informative): Configuration data file vendor-specific XML schema example	29
Annex D (normative): Session log file XML schema (file name "sessionLog.xsd")	30
Annex E (normative): BulkCMIRP Notification XML schema (file name "bulkCMIRPNotif.xsd").....	32
Annex F (informative): Void.....	34
Annex G (informative): Change history.....	35

Foreword

This Technical Specification has been produced by the 3rd Generation Partnership Project (3GPP).

The contents of the present document are subject to continuing work within the TSG and may change following formal TSG approval. Should the TSG modify the contents of the present document, it will be re-released by the TSG with an identifying change of release date and an increase in version number as follows:

Version x.y.z

where:

- x the first digit:
 - 1 presented to TSG for information;
 - 2 presented to TSG for approval;
 - 3 or greater indicates TSG approved document under change control.
- y the second digit is incremented for all changes of substance, i.e. technical enhancements, corrections, updates, etc.
- z the third digit is incremented when editorial only changes have been incorporated in the document.

Introduction

The present document is part of a TS-family covering the 3rd Generation Partnership Project; Technical Specification Group Services and System Aspects; Telecommunication management; as identified below:

- 32.611: "Configuration Management (CM); Bulk CM Integration Reference Point (IRP): Requirements".
- 32.612: "Configuration Management (CM); Bulk CM Integration Reference Point (IRP): Information Service (IS)".
- 32.613: "Configuration Management (CM); Bulk CM Integration Reference Point (IRP): Common Object Request Broker Architecture (CORBA) Solution Set (SS)".
- 32.615: "Configuration Management (CM); Bulk CM Integration Reference Point (IRP): eXtensible Markup Language (XML) file format definition".**
- 32.617: "Configuration Management (CM); Bulk CM Integration Reference Point (IRP): SOAP Solution Set (SS)".

Configuration Management (CM), in general, provides the operator with the ability to assure correct and effective operation of the 3G network as it evolves. CM actions have the objective to control and monitor the actual configuration on the Network Element (NEs) and Network Resources (NRs), and they may be initiated by the operator or functions in the Operations Systems (OSs) or NEs.

CM actions may be requested as part of an implementation programme (e.g. additions and deletions), as part of an optimisation programme (e.g. modifications), and to maintain the overall Quality of Service (QoS). The CM actions are initiated either as a single action on a NE of the 3G network or as part of a complex procedure involving actions on many NEs.

1 Scope

The present document provides the main part of the XML file format definition for the Bulk Configuration Management IRP IS in 3GPP TS 32.612 [1].

The other parts of this XML file format definition are NRM -specific parts.

Those NRM-specific parts are provided by 3GPP TS 32.625 [11], 32.635 [12], 32.645 [13], 32.655 [14], 32.695 [16], 32.715 [17], 32.735 [18], 32.745 [15], 32.755 [20], 32.765 [19], 32.525 [21], 32.175 [22], 32.725 [23], 32.775 [24] and 32.785 [25].

Bulk CM XML file formats are based on XML [2], XML Schema [3] [4] [5] and XML Namespace [6] standards.

This File Format Definition specification is related to 3GPP TS 32.612 V9.1.X.

2 References

The following documents contain provisions which, through reference in this text, constitute provisions of the present document.

- References are either specific (identified by date of publication, edition number, version number, etc.) or non-specific.
- For a specific reference, subsequent revisions do not apply.
- For a non-specific reference, the latest version applies. In the case of a reference to a 3GPP document (including a GSM document), a non-specific reference implicitly refers to the latest version of that document *in the same Release as the present document*.

- [1] 3GPP TS 32.612: "Telecommunication management; Configuration Management (CM); Bulk CM Integration Reference Point (IRP): Information Service (IS)".
- [2] W3C REC-xml-20001006: "Extensible Markup Language (XML) 1.0 (Second Edition)".
- [3] W3C REC-xmldata-model-20001002: "XML Schema Part 0: Primer".
- [4] W3C REC-xmldata-model-1-20010502: "XML Schema Part 1: Structures".
- [5] W3C REC-xmldata-model-2-20010502: "XML Schema Part 2: Datatypes".
- [6] W3C REC-xml-names-19990114: "Namespaces in XML".
- [7] 3GPP TS 32.300: "Telecommunication management; Configuration Management (CM); Name convention for Managed Objects".
- [8] 3GPP TS 32.622: "Telecommunication management; Configuration Management (CM); Generic network resources Integration Reference Point (IRP): Network Resource Model (NRM)".
- [9] Void.
- [10] Void.
- [11] 3GPP TS 32.625: "Telecommunication management; Configuration Management (CM); Generic network resources Integration Reference Point (IRP): Bulk CM eXtensible Markup Language (XML) file format definition".
- [12] 3GPP TS 32.635: "Telecommunication management; Configuration Management (CM); Core network resources Integration Reference Point (IRP): Bulk CM eXtensible Markup Language (XML) file format definition".

- [13] 3GPP TS 32.645: "Telecommunication management; Configuration Management (CM); UTRAN network resources Integration Reference Point (IRP): Bulk CM eXtensible Markup Language (XML) file format definition".
- [14] 3GPP TS 32.655: "Telecommunication management; Configuration Management (CM); GERAN network resources Integration Reference Point (IRP): Bulk CM eXtensible Markup Language (XML) file format definition".
- [15] 3GPP TS 32.745: "Telecommunication management; Configuration Management (CM); Signalling Transport Network (STN) Interface Network Resource Model (NRM) Integration Reference Point (IRP): Bulk CM eXtensible Markup Language (XML) file format definition".
- [16] 3GPP TS 32.695: "Telecommunication management; Inventory Management (IM) Network Resource Model (NRM); Integration Reference Point (IRP): eXtensible Markup Language (XML) file format definition".
- [17] 3GPP TS 32.715: "Telecommunication management; Configuration Management (CM); Transport Network (TN) interface Network Resource Model (NRM) Integration Reference Point (IRP): Bulk CM eXtensible Markup Language (XML) file format definition".
- [18] 3GPP TS 32.735: "IP Multimedia Subsystem (IMS) Network Resource Model (NRM) Integration Reference Point (IRP): Bulk CM eXtensible Markup Language (XML) file format definition".
- [19] 3GPP TS 32.765: "Telecommunication management; Evolved Universal Terrestrial Radio Access Network (E UTRAN) Network Resource Model (NRM) Integration Reference Point (IRP): eXtensible Markup Language (XML) definitions".
- [20] 3GPP TS 32.755: "Telecommunication management; Evolved Packet Core (EPC) Network Resource Model (NRM) Integration Reference Point (IRP): eXtensible Markup Language (XML) definitions".
- [21] 3GPP TS 32.525: "Telecommunication management; Self-Organizing Networks (SON) Policy Network Resource Model (NRM) Integration Reference Point (IRP): eXtensible Markup Language (XML) file format definition".
- [22] 3GPP TS 32.175: "Telecommunication management; Subscription Management (SuM) Network Resource Model (NRM) Integration Reference Point (IRP): eXtensible Markup Language (XML) definition".
- [23] 3GPP TS 32.725: "Telecommunication management; Configuration Management (CM); Repeater network resources Integration Reference Point (IRP); Bulk CM eXtensible Markup Language (XML) file format definition".
- [24] 3GPP TS 32.775: "Telecommunication management; Home Node B (HNB) Subsystem (HNS); Network Resource Model (NRM); Integration Reference Point (IRP); Bulk CM eXtensible Markup Language (XML) file format definition".
- [25] 3GPP TS 32.785: "Telecommunication management; Home enhanced Node B (HeNB) Subsystem (HeNS); Network Resource Model (NRM); Integration Reference Point (IRP); Bulk CM eXtensible Markup Language (XML) file format definition".

3 Definitions and abbreviations

3.1 Definitions

For the purposes of the present document, the following terms and definitions apply.

XML file: a file containing an XML document.

XML document: see [2]; in the scope of this specification, an XML document is composed of the succession of an optional XML declaration followed by a root XML element.

XML declaration: see [2]; it specifies the version of XML and the character encoding being used.

XML element: see [2]; an XML element has a type, is identified by a name, may have a set of XML attribute specifications and is either composed of the succession of an XML start-tag followed by the XML content of the XML element followed by an XML end-tag, or composed simply of an XML empty-element tag; each XML element may contain other XML elements.

empty XML element: see [2]; an XML element having an empty XML content; an empty XML element still possibly has a set of XML attribute specifications; an empty XML element is either composed of the succession of an XML start-tag directly followed by an XML end-tag, or composed simply of an XML empty-element tag.

XML content (of an XML element): empty if the XML element is simply composed of an XML empty-element tag; otherwise the part, possibly empty, of the XML element between its XML start-tag and its XML end-tag.

XML start-tag: see [2]; the beginning of a non-empty XML element is marked by an XML start-tag containing the name and the set of XML attribute specifications of the XML element.

XML end-tag: see [2]; the end of a non-empty XML element is marked by an XML end-tag containing the name of the XML element.

XML empty-element tag: see [2]; an empty XML element is composed simply of an empty-element tag containing the name and the set of XML attribute specifications of the XML element.

XML attribute specification: see [2]; an XML attribute specification has a name and a value.

DTD: see [2]; a DTD defines structure and content constraints to be respected by an XML document to be valid with regard to this DTD.

XML schema: see [3], [4] and [5]; more powerful than a DTD, an XML schema defines structure and content constraints to be respected by an XML document to conform with this XML schema; through the use of XML namespaces several XML schemas can be used together by a single XML document; an XML schema is itself also an XML document that shall conform with the XML schema for XML schemas.

XML namespace: see [6]; in the scope of this specification, enables qualifying element and attribute names used in XML documents by associating them with namespaces identified by different XML schemas.

XML complex type: see [3], [4] and [5]; defined in an XML schema; cannot be directly used in an XML document; can be the concrete type or the derivation base type for an XML element type or for another XML complex type; ultimately defines constraints for an XML element on its XML attribute specifications and/or its XML content.

XML element type: see [3], [4] and [5]; declared by an XML schema; can be directly used in an XML document; as the concrete type of an XML element, directly or indirectly defines constraints on its XML attribute specifications and/or its XML content; can also be the concrete type or the derivation base type for another XML element type.

3.2 Abbreviations

For the purposes of the present document, the following abbreviations apply:

CM	Configuration Management
DTD	Document Type Definition
DN	Distinguished Name
EDGE	Enhanced Data for GSM Evolution
GERAN	GSM/EDGE Radio Access Network
GSM	Global System for Mobile communication
IRP	Integration Reference Point
IS	Information Service
NRM	Network Resource Model
RDN	Relative Distinguished Name
UMTS	Universal Mobile Telecommunications System
UTRAN	Universal Terrestrial Radio Access Network
XML	eXtensible Markup Language

4 Structure and content of configuration data XML files

The present clause defines the file format of configuration data XML files exchanged between an IRPManager and an IRPAgent as part of upload and download operations of the Bulk CM IRP IS (see [1]).

Upload and download configuration data XML files share a common file format defined by the XML schema in Annex A and by the following clauses.

Additionally, vendor-specific XML schemas shall be provided to enable configuration data XML files to carry vendor-specific data (see clause 4.5).

The use of XML schemas enables to ensure configuration data XML files have the proper structure and to some extent the proper content, and in particular to ensure:

- for a given NRM instance, it is properly named/positioned with regard to the global NRM naming tree;
- for a given NRM instance, only attributes of the corresponding NRM class are present;
- for a given NRM attribute, its value is of the proper type.

Location of the XML schemas used for configuration data XML files is outside the scope of this document.

4.1 Global structure

The content of a configuration data XML file is the succession of:

- the standard XML declaration with specification of the version of XML and of the character encoding being used (see [2]);
- a `bulkCmConfigDataFile` XML element; this is the root XML element of configuration data XML files.

The definition of the allowed character encoding(s) is outside the scope of this document.

As defined by the following extract of XML schema `configData.xsd` (see Annex A):

```
<element name="bulkCmConfigDataFile">
  <complexType>
    <sequence>
      <element name="fileHeader">
[...]
      </element>
      <element name="configData" maxOccurs="unbounded">
[...]
      </element>
      <element name="fileFooter">
[...]
      </element>
    </sequence>
  </complexType>
</element>
```

the XML content of a `bulkCmConfigDataFile` XML element is the succession of:

- a `fileHeader` XML element (see clause 4.2);
- one or several `configData` XML elements (see clause 4.3);
- a `fileFooter` XML element (see clause 4.2).

XML elements `fileHeader` and `fileFooter` are empty XML elements (see clause 4.2).

The `bulkCmConfigDataFile` XML element shall also have all the XML attribute specifications that declare the XML namespaces (see [6]) used in the XML file.

The following XML namespaces are potentially used in configuration data XML files:

- the default XML namespace is associated with the configuration data files base XML schema `configData.xsd` (see Annex A);
- for each NRM-specific XML schema, a specific XML namespace prefix is defined for the associated XML namespace (see clause 4.3A.1);
- XML namespaces prefixes starting with `vs`, e.g. `vsRHO11`, are reserved for the XML namespaces associated with the vendor-specific XML schemas (see clause 4.5).

Each `configData` XML element (see clause 4.3) carries:

- NRM instances with or without their NRM attribute values in a NRM naming tree organized structure together with `modifier` XML attribute specification (see clause 4.4);
- possibly vendor-specific data (see clause 4.5).

A `configData` XML element can carry an entire tree of NRM instances with their NRM attribute values and the related vendor-specific data or any subset of it.

The following is an example of a configuration data XML file, without presentation of the XML attribute specifications and XML content of `fileHeader`, `configData` and `fileFooter` XML elements (replaced by [...]; see clauses 4.2, 4.3, 4.4 and 4.5):

```
<?xml version="1.0" encoding="UTF-8"?>
<bulkCmConfigDataFile
  xmlns=
"http://www.3gpp.org/ftp/specs/archive/32_series/32.615#configData"
[...]
```

>

```
  <fileHeader [...]/>
  <configData [...]>
[...]
```

</configData>

```
  <configData [...]>
[...]
```

</configData>

```
  <fileFooter [...]/>
</bulkCmConfigDataFile>
```

4.2 XML elements fileHeader and fileFooter

4.2.1 XML element fileHeader

As defined by the following extract of XML schema configData.xsd (see Annex A):

```
<element name="fileHeader">
  <complexType>
    <attribute name="fileFormatVersion" type="string" use="required"/>
    <attribute name="senderName" type="string" use="optional"/>
    <attribute name="vendorName" type="string" use="optional"/>
  </complexType>
</element>
```

a fileHeader XML element:

- has the following XML attribute specifications:
 - a fileFormatVersion XML attribute specification; this attribute specification carries the abridged number and version of this 3GPP document (see below); this identifies the version of the file format used for assembling the XML file;
 - a conditional senderName XML attribute specification; this attribute specification shall be present only in XML files generated by the IRPAgent; it carries the DN of the IRPAgent that assembled the XML file, i.e. the value of the systemDN NRM attribute of the IRPAgent NRM instance (see [8]);
 - a conditional vendorName XML attribute specification; this attribute specification shall be present only in XML files generated by the IRPAgent; it carries the name of the vendor of the IRPAgent that assembled the XML file;
- and has an empty XML content.

The abridged number and version of a 3GPP document is constructed from its version specific full reference "3GPP [...] (yyyy-mm)" by:

- removing the leading "3GPP TS";
- removing everything including and after the version third digit, representing editorial only changes, together with its preceding dot character;
- from the resulting string, removing leading and trailing white space, replacing every multi character white space by a single space character and changing the case of all characters to uppercase.

The following is an example of a fileHeader XML element:

```
<fileHeader
  fileFormatVersion="32.615 V4.0"
  senderName="DC=al.companyNN.com,SubNetwork=1,IRPAgent=1"
  vendorName="Company NN"
/>
```

4.2.2 XML element fileFooter

As defined by the following extract of XML schema configData.xsd (see Annex A):

```
<element name="fileFooter">
  <complexType>
    <attribute name="dateTime" type="dateTime" use="required"/>
  </complexType>
</element>
```

a fileFooter XML element:

- has a `dateTime` XML attribute specification; this attribute specification carries the date and time the XML file was assembled;
- and has an empty XML content.

The following is an example of a `fileFooter` XML element:

```
<fileFooter dateTime="2001-05-07T12:00:00+02:00"/>
```

4.3 XML element configData

As defined by the following extract of XML schema configData.xsd (see Annex A):

```
<element name="configData" maxOccurs="unbounded">
  <complexType>
    <choice>
      <element ref="xn:SubNetwork"/>
      <element ref="xn:MeContext"/>
      <element ref="xn:ManagedElement"/>
    </choice>
    <attribute name="dnPrefix" type="string" use="optional"/>
  </complexType>
</element>
```

a configData XML element:

- has an optional dnPrefix XML attribute specification; this attribute specification carries the DN Prefix information as defined in Annex C of 3GPP TS 32.300 [7];
- and its XML content is an instance of the specific type of XML element (see below) corresponding to one of the NRM classes SubNetwork, MeContext or ManagedElement (see [8]); depending on the System Context of the IRP (see [1]) the used NRM class shall be:
 - in case of System Context A, only SubNetwork NRM class, or;
 - in case of System Context B, only MeContext or ManagedElement NRM class.

This instance of SubNetwork/MeContext/ManagedElement NRM class corresponding specific XML element type is the starting point for a configData XML element to possibly contain several NRM instances in a NRM naming tree organized structure (see clause 4.3A.2).

The following is an example of a configData XML element:

```
<configData dnPrefix="DC=a1.companyNN.com">
  <xn:SubNetwork [...]>
[...]
```

```
</xn:SubNetwork>
</configData>
```

4.3A NRM-specific XML elements

NRM-specific XML element types are generically defined under the mapping rules defined in clause 4.3A.2.

NRM-specific XML element types are explicitly declared by NRM-specific XML schemas as defined in clause 4.3A.1.

4.3A.1 NRM-specific XML schemas

NRM-specific XML schemas are defined in the NRM-specific parts (see clause 1) of the XML file format definition for the Bulk Configuration Management IRP IS [1].

NRM-specific XML schemas with definition of corresponding XML namespace prefixes (see clause 4.1) are listed by the following table:

Table 2: NRM-specific XML schemas, corresponding 3GPP TSs and XML namespace prefixes

NRM	XML schema	3GPP TS no.	XML namespace prefix
Core Network Resources	coreNrm.xsd	32.635 [12]	cn
Generic Network Resources	genericNrm.xsd	32.625 [11]	xn
GERAN Network Resources	geranNrm.xsd	32.655 [14]	gn
IM Network Resources	inventoryNrm.xsd	32.695 [16]	in
IMS NRM	imsNrm.xsd	32.735 [18]	im
STN Network Resources	stnNrm.xsd	32.745 [15]	stn
TN Network Resources	transportNrm.xsd	32.715 [17]	tn
UTRAN Network Resources	utranNrm.xsd	32.645 [13]	un
E-UTRAN Network Resources	eutranNrm.xsd	32.765 [19]	en
EPC Network Resources	epcNrm.xsd	32.755 [20]	epc
SON Policy Network Resources	sonPolicyNrm.xsd	32.525 [21]	sp
Subscription Management Network Resources	sumNrm.xsd	32.175 [22]	sn
Repeater Network Resources	RepeaterNrm.xsd	32.725 [23]	rn
HNS Network Resources	hnsNrm.xsd	32.775 [24]	hn
HeNS Network Resources	hensNrm.xsd	32.785 [25]	hen

Each NRM-specific XML schema explicitly declares NRM-specific XML element types for the related NRM.

Additionally, XML schema `genericNrm.xsd` (see [11]) also provides global XML declarations and definitions for the support of:

- NRM-specific XML element type declaration;
- vendor-specific XML element type declaration (see clause 4.5).

4.3A.2 Generic mapping rules

NRM-specific XML element types are generically defined under the following mapping rules:

- to each NRM class corresponds a specific type of XML element having the following characteristics:
 - its name is the name of the NRM class;
 - it derives by extension (see [3], [4] and [5]) the `NrmClass` XML complex type defined in the XML schema `genericNrm.xsd` (see [11]);
 - it has the following XML attribute specifications, inherited from `NrmClass` XML complex type:
 - an `id` XML attribute specification; this attribute specification carries the attribute value part of the RDN of the NRM instance carried by the XML element, i.e. the value of the naming attribute of this NRM instance;

- an optional `modifier` XML attribute specification (see clause 4.4);
- and its XML content is the succession of:
 - an optional `attributes` XML element whose XML content is the succession of:
 - zero or more specific XML elements (see below) corresponding to attributes of the NRM class, each occurring not more than once;
 - zero or more similar specific XML elements corresponding to direct subordinate NRM classes of the NRM class to which the current XML element corresponds;
- to each NRM attribute of each NRM class, except for the following NRM attributes:
 - the naming NRM attribute of each NRM class, whose value is already carried by the `id` XML attribute specification of the specific XML element corresponding to the NRM class;
 - the conditional `dnPrefix` NRM attribute of `SubNetwork`, `MeContext` and `ManagedElement` NRM classes (see [8]), whose value is already carried by the `dnPrefix` XML attribute specification of the `configData` XML element;

corresponds a specific type of XML element having the following characteristics:

- its name is constructed from the name of the NRM attribute by removing any contained dash character;
- and it has an XML content; this XML content carries the value of the NRM attribute.

For example for the `SubNetwork` NRM class (see [8]), the corresponding extract of XML schema `genericNrm.xsd` (see [11]) is the following:

```
<element name="SubNetwork">
  <complexType>
    <complexContent>
      <extension base="xn:NrmClass">
        <sequence>
          <element name="attributes" minOccurs="0">
            <complexType>
              <all>
                <element name="userLabel" minOccurs="0"/>
                <element name="userDefinedNetworkType" minOccurs="0"/>
              </all>
            </complexType>
          </element>
          <choice minOccurs="0" maxOccurs="unbounded">
            <element ref="xn:SubNetwork"/>
            <element ref="xn:ManagedElement"/>
            <element ref="xn:MeContext"/>
            <element ref="xn:ManagementNode"/>
            <element ref="xn:IRPAgent"/>
            <element ref="xn:SubNetworkOptionallyContainedNrmClass"/>
          </choice>
        </sequence>
      </extension>
    </complexContent>
  </complexType>
</element>
```

supported by the following extract of XML schema `genericNrm.xsd` (see [11]):

```
<complexType name="NrmClass">
  <attribute name="id" type="string" use="required"/>
  <attribute name="modifier" use="optional">
[...]
```

Exceptions to the generic mapping rules for the definition of NRM-specific XML element types are listed by the following table:

Table 3: Generic mapping rule exceptions

NRM classes / attributes	NRM 3GPP TS no.	Exception description references
vsData attribute of VsDataContainer class	32.622 [8]	clause 4.5 of the present document and annex A of 3GPP TS 32.625 [11]

The following is an example of a configData XML element with regard to NRM-specific XML elements (in **bold**) in a configuration data XML file:

```
<?xml version="1.0" encoding="UTF-8"?>
<bulkCmConfigDataFile
  xmlns=
"http://www.3gpp.org/ftp/specs/archive/32_series/32.615#configData"
  xmlns:xn=
"http://www.3gpp.org/ftp/specs/archive/32_series/32.625#genericNrm"
[...]
```

```
>
[...]
```

```
<configData dnPrefix="DC=a1.companyNN.com">
  <xn:SubNetwork id="1">
    <xn:attributes>
      <xn:userLabel>Paris SN1</xn:userLabel>
      <xn:userDefinedNetworkType>UMTS</xn:userDefinedNetworkType>
    </xn:attributes>
    <xn:ManagementNode id="1">
      <xn:attributes>
        <xn:userLabel>Paris MN1</xn:userLabel>
        <xn:vendorName>Company NN</xn:vendorName>
        <xn:userDefinedState>commercial</xn:userDefinedState>
        <xn:locationName>Montparnasse</xn:locationName>
      </xn:attributes>
    </xn:ManagementNode>
    <xn:ManagedElement id="1">
      <xn:attributes>
        <xn:managedElementType>RNC</xn:managedElementType>
        <xn:userLabel>Paris RN1</xn:userLabel>
        <xn:vendorName>Company NN</xn:vendorName>
        <xn:userDefinedState>commercial</xn:userDefinedState>
        <xn:locationName>Champ de Mars</xn:locationName>
      </xn:attributes>
    </xn:ManagedElement>
    <xn:ManagedElement id="2">
      <xn:attributes>
        <xn:managedElementType>RNC</xn:managedElementType>
        <xn:userLabel>Paris RN2</xn:userLabel>
        <xn:vendorName>Company NN</xn:vendorName>
        <xn:userDefinedState>commercial</xn:userDefinedState>
        <xn:locationName>Concorde</xn:locationName>
      </xn:attributes>
    </xn:ManagedElement>
  </xn:SubNetwork>
</configData>
[...]
```

```
</bulkCmConfigDataFile>
```

4.4 XML attribute specification modifier

As defined by the following extract of XML schema `genericNrm.xsd` (see [11]):

```
<attribute name="modifier" use="optional">
  <simpleType>
    <restriction base="string">
      <enumeration value="create"/>
      <enumeration value="delete"/>
      <enumeration value="update"/>
    </restriction>
  </simpleType>
</attribute>
```

the value of the optional `modifier` XML attribute specification of the specific XML elements corresponding to the classes of the NRM is one of the following: `create`, `delete`, or `update`.

The semantic carried by a `modifier` XML attribute specification applies only to the NRM instance corresponding to the containing XML element and not to any explicit or implicit subordinate NRM instances of this NRM instance.

The following rules apply for the `modifier` XML attribute specification:

- in upload XML configuration files, no `modifier` XML attribute specification should be present; on the contrary those are to be considered as meaningless and shall be ignored;
- in download XML configuration files:
 - if an XML element carrying an NRM instance has a `modifier` XML attribute specification of value `create`, then all directly or indirectly contained XML element carrying NRM instances, if any, shall also have a `modifier` XML attribute specification of value `create`;
 - if an XML element carrying an NRM instance has a `modifier` XML attribute specification of value `delete`, then all directly or indirectly contained XML element carrying NRM instances, if any, shall also have a `modifier` XML attribute specification of value `delete`;
 - if an XML element carrying an NRM instance has a `modifier` XML attribute specification of value `update`, then all directly contained XML element carrying NRM instances, if any, may also have a `modifier` XML attribute specification, this one being of either value `create`, `delete`, or `update`;
 - if an XML element carrying an NRM instance has no `modifier` XML attribute specification or a `modifier` XML attribute specification of value `delete`, then it shall not directly contain an `attributes` XML element.

A tree of XML elements corresponding to a tree of NRM instances with all XML elements having a `modifier` XML attribute specification of value `create` is considered to be in accordance with the following rule from Bulk CM IRP IS 3GPP TS 32.612 [1]:

"When part or a whole NRM subtree is to be created, in the configuration data file the IRPManager shall first action the create action of parents MO instances before actioning the create of any child MO instances contained in the NRM subtree i.e. create actions on MO instances shall be specified in recursive manner following the NRM hierarchy subtree from the highest MO instances to the lowest MO instances the IRPManager requires to be created."

In such a tree of NRM instances, the XML element carrying a given NRM instance does not accurately appear before XML elements carrying subordinate NRM instances. The latter XML elements rather appear as the last part of the XML content of the former XML element.

Nevertheless, XML parsing of such a tree of NRM instances can still enable the above Bulk CM IRP IS rule to be fully respected. Example of an XML parsing enabling such compliance is one effectively actioning the creation of each NRM instance when having parsed the XML start-tag of the XML element carrying the NRM instance and, if any, the contained `attributes` XML element.

A tree of XML elements corresponding to a tree of NRM instances with all XML elements having a `modifier` XML attribute specification of value `delete` is considered to be in accordance with the following rule from Bulk CM IRP IS 3GPP TS 32.612 [1]:

"When part or whole NRM subtree is to be deleted, in the configuration data file the IRPManager shall first action delete of all associated child instances contained in the NRM subtree before actioning delete of MO parents instances i.e. delete actions on MO instances shall be specified in a recursive manner following the NRM hierarchy subtree from the lowest MO instances to the highest MO instances the IRPManager requires to be deleted."

In such a tree of NRM instances, the XML elements carrying subordinate NRM instances do not appear before the XML element carrying the parent NRM instance. The former XML elements rather appear as the XML content of the latter XML element.

Nevertheless, XML parsing of such a tree of NRM instances can still enable the above Bulk CM IRP IS rule to be fully respected. Example of an XML parsing enabling such compliance is one effectively actioning the delete of each NRM instance when parsing the XML end-tag of the XML element carrying the NRM instance.

The following are examples of legal `configData` XML element with regard to `modifier` XML attribute specification (in **bold**) in configuration data XML files:

- example 1:

```
<?xml version="1.0" encoding="UTF-8"?>
<bulkCmConfigDataFile
  xmlns=
"http://www.3gpp.org/ftp/specs/archive/32_series/32.615#configData"
  xmlns:xn=
"http://www.3gpp.org/ftp/specs/archive/32_series/32.625#genericNrm"
[...]
>
[...]
<configData dnPrefix="DC=a1.companyNN.com">
  <xn:SubNetwork id="1" modifier="create">
    <xn:attributes>
      <xn:userLabel>Paris SN1</xn:userLabel>
      <xn:userDefinedNetworkType>UMTS</xn:userDefinedNetworkType>
    </xn:attributes>
    <xn:ManagementNode id="1" modifier="create">
      <xn:attributes>
        <xn:userLabel>Paris MN1</xn:userLabel>
[...]
        <xn:locationName>Montparnasse</xn:locationName>
      </xn:attributes>
    </xn:ManagementNode>
    <xn:ManagedElement id="1" modifier="create">
      <xn:attributes>
        <xn:managedElementType>RNC</xn:managedElementType>
[...]
        <xn:locationName>Champ de Mars</xn:locationName>
      </xn:attributes>
    </xn:ManagedElement>
    <xn:ManagedElement id="2" modifier="create">
      <xn:attributes>
        <xn:managedElementType>RNC</xn:managedElementType>
[...]
        <xn:locationName>Concorde</xn:locationName>
      </xn:attributes>
    </xn:ManagedElement>
  </xn:SubNetwork>
</configData>
[...]
</bulkCmConfigDataFile>
```

- example 2:

```
<?xml version="1.0" encoding="UTF-8"?>
<bulkCmConfigDataFile
  xmlns=
"http://www.3gpp.org/ftp/specs/archive/32_series/32.615#configData"
  xmlns:xn=
"http://www.3gpp.org/ftp/specs/archive/32_series/32.625#genericNrm"
```

```
[...]
>
[...]
```

`<configData dnPrefix="DC=a1.companyNN.com">
 <xn:SubNetwork id="1">
 <xn:ManagedElement id="1" modifier="create">
 <xn:attributes>
 <xn:managedElementType>RNC</xn:managedElementType>
[...]`

```
    <xn:locationName>Champ de Mars</xn:locationName>
  </xn:attributes>
</xn:ManagedElement>
<xn:ManagedElement id="2" modifier="create">
  <xn:attributes>
    <xn:managedElementType>RNC</xn:managedElementType>
[...]
```

```
    <xn:locationName>Concorde</xn:locationName>
  </xn:attributes>
</xn:ManagedElement>
</xn:SubNetwork>
</configData>
[...]
```

```
</bulkCmConfigDataFile>
```

- example 3:

```
<?xml version="1.0" encoding="UTF-8"?>
<bulkCmConfigDataFile
  xmlns=
"http://www.3gpp.org/ftp/specs/archive/32_series/32.615#configData"
  xmlns:xn=
"http://www.3gpp.org/ftp/specs/archive/32_series/32.625#genericNrm"
[...]
```

```
>
[...]
```

`<configData dnPrefix="DC=a1.companyNN.com">
 <xn:SubNetwork id="1" modifier="delete">
 <xn:ManagementNode id="1" modifier="delete">
 </xn:ManagementNode>
 <xn:ManagedElement id="1" modifier="delete">
 </xn:ManagedElement>
 <xn:ManagedElement id="2" modifier="delete">
 </xn:ManagedElement>
 </xn:SubNetwork>
</configData>
[...]`

```
</bulkCmConfigDataFile>
```

- example 4:

```
<?xml version="1.0" encoding="UTF-8"?>
<bulkCmConfigDataFile
  xmlns=
"http://www.3gpp.org/ftp/specs/archive/32_series/32.615#configData"
  xmlns:xn=
"http://www.3gpp.org/ftp/specs/archive/32_series/32.625#genericNrm"
[...]
```

```
>
[...]
```

`<configData dnPrefix="DC=a1.companyNN.com">
 <xn:SubNetwork id="1">
 <xn:ManagedElement id="1" modifier="delete">
 </xn:ManagedElement>
 <xn:ManagedElement id="2" modifier="delete">
 </xn:ManagedElement>
 </xn:SubNetwork>
</configData>
[...]`

```
</bulkCmConfigDataFile>
```

- example 5:

```
<?xml version="1.0" encoding="UTF-8"?>
<bulkCmConfigDataFile
```

```
xmlns=
"http://www.3gpp.org/ftp/specs/archive/32_series/32.615#configData"
xmlns:xn=
"http://www.3gpp.org/ftp/specs/archive/32_series/32.625#genericNrm"
xmlns:un=
"http://www.3gpp.org/ftp/specs/archive/32_series/32.645#utranNrm"
[...]
>
[...]
<configData dnPrefix="DC=a1.companyNN.com">
  <xn:SubNetwork id="1" modifier="update">
    <xn:attributes>
      <xn:userLabel>Paris SN1</xn:userLabel>
    </xn:attributes>
    <xn:ManagementNode id="1" modifier="update">
      <xn:attributes>
        <xn:userLabel>Paris MN1</xn:userLabel>
      </xn:attributes>
    </xn:ManagementNode>
    <xn:ManagedElement id="1" modifier="delete">
      <un:RncFunction id="1" modifier="delete">
        </un:RncFunction>
      </xn:ManagedElement>
    <xn:ManagedElement id="2" modifier="create">
      <xn:attributes>
        <xn:managedElementType>RNC</xn:managedElementType>
        <xn:locationName>Concorde</xn:locationName>
      </xn:attributes>
      <un:RncFunction id="2" modifier="create">
        <un:attributes>
          <un:userLabel>Paris RF2</un:userLabel>
        </un:attributes>
      </un:RncFunction>
    </xn:ManagedElement>
    <xn:ManagedElement id="3">
      <un:RncFunction id="3" modifier="update">
        <un:attributes>
          <un:userLabel>Paris RF3</un:userLabel>
        </un:attributes>
      </un:RncFunction>
    </xn:ManagedElement>
  </xn:SubNetwork>
</configData>
[...]
</bulkCmConfigDataFile>
```

4.5 XML elements VsDataContainer, vsData and vsDataFormatVersion

As all XML element types corresponding to NRM classes (see clause 4.3A.2), the VsDataContainer XML element type, explicitly declared in 3GPP TS 32.625 [11], corresponds to the VsDataContainer NRM class defined in 3GPP TS 32.622 [8].

Contained in an attributes XML element type, itself contained in a VsDataContainer XML element, as all XML element types corresponding to NRM attributes (see clause 4.3A.2), the vsData and vsDataFormatVersion XML element types, explicitly declared in 3GPP TS 32.625 [11], correspond to the vsData and vsDataFormatVersion NRM attributes defined in 3GPP TS 32.622 [8].

As an exception to the generic mapping rules for the definition of NRM-specific XML element types (see clause 4.3A.2), the vsData XML element type has an empty XML content.

Each vendor-specific XML schema shall declare one or more vendor-specific XML element types that:

- have a name starting with vsData, e.g. vsDataRHO;
- derive by extension (see [3], [4] and [5]) the vsData XML element type declared by the XML schema genericNrm.xsd (see [11]);
- are designated as members of the substitution group (see [3], [4] and [5]) headed by the vsData XML element type.

Beyond the above statement, the definition of vendor-specific XML schemas is outside the scope of this document.

The XML content of those vendor-specific XML elements carry vendor-specific data.

The XML content of the vsDataFormatVersion XML element shall be the filename, without the ".xsd" file extension and without any path specification, of the vendor-specific XML schema used for the related VsDataContainer XML element.

See Annex C for an example of a vendor-specific XML schema.

The following is an example of a vendor-specific XML element (in **bold**) deriving and extending the vsData XML element in a configuration data XML file:

```
<?xml version="1.0" encoding="UTF-8"?>
<bulkCmConfigDataFile
  xmlns=
"http://www.3gpp.org/ftp/specs/archive/32_series/32.615#configData"
  xmlns:xn=
"http://www.3gpp.org/ftp/specs/archive/32_series/32.625#genericNrm"
  xmlns:un=
"http://www.3gpp.org/ftp/specs/archive/32_series/32.645#utranNrm"
  xmlns:vsRH011="http://www.companyNN.com/xmlschemas/NNRncHandOver.1.1"
[...]
```

```
>
[...]
```

```
<configData dnPrefix="DC=a1.companyNN.com">
  <xn:SubNetwork id="1">
    <xn:ManagedElement id="1">
      <un:RncFunction id="1">
        <xn:VsDataContainer id="1">
          <xn:attributes>
            <xn:vsDataType>RncHandOver</xn:vsDataType>
            <xn:vsDataFormatVersion>NNRncHandOver.1.1</xn:vsDataFormatVersion>
            <vsRH011:vsDataRHO>
              <vsRH011:abcMin>12</vsRH011:abcMin>
              <vsRH011:abcMax>34</vsRH011:abcMax>
            </vsRH011:vsDataRHO>
          </xn:attributes>
        </xn:VsDataContainer>
      </un:RncFunction>
    </xn:ManagedElement>
  </xn:SubNetwork>
</configData>
[...]
```

```
</bulkCmConfigDataFile>
```

5 Structure and content of session log XML files

The present clause defines the file format of session log XML files exchanged between an IRPManager and an IRPAgent as part of `getSessionLog` operation of the Bulk CM IRP IS (see [1]).

This file format is defined by the XML schema in Annex D and by the following clauses.

The use of an XML schema enables to ensure session log XML files have the proper structure and to some extent the proper content.

Location of the XML schemas used for session log XML files is outside the scope of this document.

5.1 Global structure

The content of a session log XML file is the succession of:

- the standard XML declaration with specification of the version of XML and of the character encoding being used (see [2]);
- a `bulkCmSessionLogFile` XML element; this is the root XML element of session log XML files.

The definition of the allowed character encoding(s) is outside the scope of this document.

As defined by the following extract of XML schema `sessionLog.xsd` (see Annex D):

```
<element name="bulkCmSessionLogFile">
  <complexType>
    <sequence>
      <element name="fileHeader">
[...]
```

```
      </element>
      <element name="activity" maxOccurs="unbounded">
[...]
```

```
      </element>
      <element name="fileFooter">
[...]
```

```
      </element>
    </sequence>
  </complexType>
</element>
```

the XML content of a `bulkCmSessionLogFile` XML element is the succession of:

- a `fileHeader` XML element (see clause 5.2);
- one or several `activity` XML elements (see clause 5.3);
- a `fileFooter` XML element (see clause 5.2).

XML elements `fileHeader` and `fileFooter` are empty XML elements (see clause 5.2).

The `bulkCmSessionLogFile` XML element shall also have all the XML attribute specifications that declare the XML namespaces (see [6]) used in the XML file.

Only the default XML namespace is used in session log XML files. It is associated with the session log file XML schema `sessionLog.xsd` (see Annex D).

The following is an example of a session log XML file, without presentation of the XML attribute specifications and XML content of `fileHeader`, `activity` and `fileFooter` XML elements (replaced by [...]; see clauses 5.2 and 5.3):

```
<?xml version="1.0" encoding="UTF-8"?>
<bulkCmSessionLogFile
  xmlns=
"http://www.3gpp.org/ftp/specs/archive/32_series/32.615#sessionLog"
[...]
```

```

    <fileHeader [...] />
    <activity [...] >
[... ]
    </activity >
    <activity [...] >
[... ]
    </activity >
    <fileFooter [...] />
</bulkCmSessionLogFile >

```

5.2 XML elements fileHeader and fileFooter

The XML elements fileHeader and fileFooter for session log XML files have the same definition, structure and content as the XML elements fileHeader and fileFooter for configuration data XML files (see clause 4.2).

5.3 XML element activity

As defined by the following extract of XML schema sessionLog.xsd (see Annex D):

```

<element name="activity" minOccurs="0" maxOccurs="unbounded">
  <complexType>
    <sequence>
      <element name="log" maxOccurs="unbounded">
[... ]
        </element>
      </sequence>
      <attribute name="dateTime" type="dateTime" use="required" />
      <attribute name="type" use="required">
        <simpleType>
          <restriction base="string">
            <enumeration value="upload" />
            <enumeration value="download" />
            <enumeration value="validate" />
            <enumeration value="preactivate" />
            <enumeration value="activate" />
            <enumeration value="fallback" />
          </restriction>
        </simpleType>
      </attribute>
    </complexType>
  </element>

```

an activity XML element:

- has the following XML attribute specifications:
 - a dateTime XML attribute specification; this attribute specification carries the date and time the Bulk CM activity was started;
 - a type XML attribute specification; this attribute specification carries the type of the Bulk CM activity triggered by the IRPManager, upload, download, validate, preactivate, activate or fallback;
- and its XML content is the succession of one or several log XML elements.

As defined by the following extract of XML schema sessionLog.xsd (see Annex D):

```

<element name="log" maxOccurs="unbounded">
  <complexType>
    <simpleContent>
      <extension base="string">
        <attribute name="time" type="time" use="required" />
        <attribute name="type" use="required">
          <simpleType>
            <restriction base="string">
              <enumeration value="informative" />
              <enumeration value="error" />
            </restriction>
          </simpleType>
        </attribute>
      </extension>
    </simpleContent>
  </complexType>

```

```

    <attribute name="dn" type="string" use="optional"/>
    <attribute name="modifier" use="optional">
      <simpleType>
        <restriction base="string">
          <enumeration value="create"/>
          <enumeration value="delete"/>
          <enumeration value="update"/>
        </restriction>
      </simpleType>
    </attribute>
  </extension>
</simpleContent>
</complexType>
</element>

```

a log XML element:

- has the following XML attribute specifications:
 - a time XML attribute specification; this attribute specification carries the time the logged Bulk CM internal event occurred;
 - a type XML attribute specification; this attribute specification carries the type of the logged Bulk CM internal event, being either informative or error;
 - an optional dn XML attribute specification; this attribute specification carries the DN of the NRM instance associated with the logged Bulk CM internal event, if any;
 - an optional modifier XML attribute specification; this attribute specification carries the value of the modifier (see clause 4.4) associated with the NRM instance, if any;
- and it has an XML content; this XML content carries the description of the logged Bulk CM internal event.

The following is an example of an activity XML element (in **bold**) in a session log XML file:

```

<?xml version="1.0" encoding="UTF-8"?>
<bulkCmSessionLogFile
  xmlns=
"http://www.3gpp.org/ftp/specs/archive/32_series/32.615#sessionLog"
[... ]
>
[... ]
  <activity dateTime="2001-05-07T12:00:00+02:00" type="download">
    <log time="12:00:01+02:00" type="informative">
      Download requested with:
      downloadDataFileReference="ftp://a1.companyNN.com/data/upld123.xml"
    </log>
    <log time="12:00:02+02:00" type="error"
      dn="DC=a1.companyNN.com,SubNetwork=1"
      modifier="update"
    >
      No such instance
    </log>
  </activity>
[... ]
</bulkCmSessionLogFile>

```

6 BulkCMIRP Notification XML Definitions

This clause provides XML definitions of Notification Log IRP notifications as defined in [1].

The structure of the BulkCMIRP Notification XML Definitions is shown in graphical depiction below:

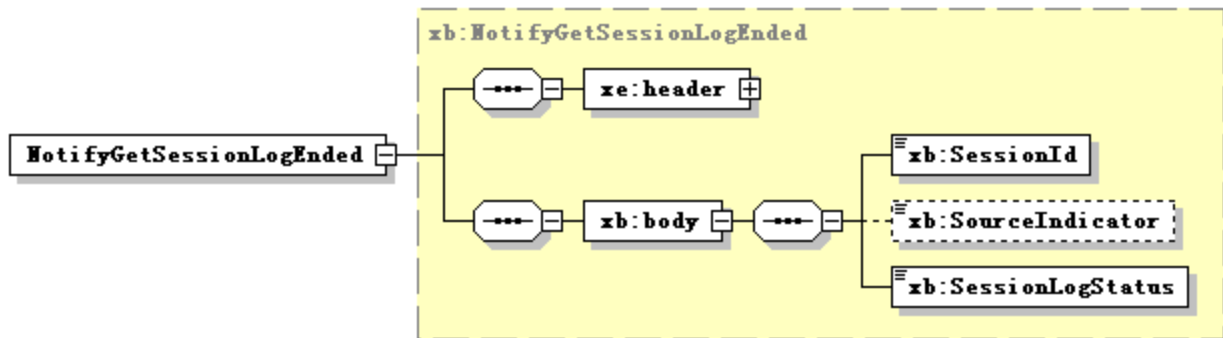
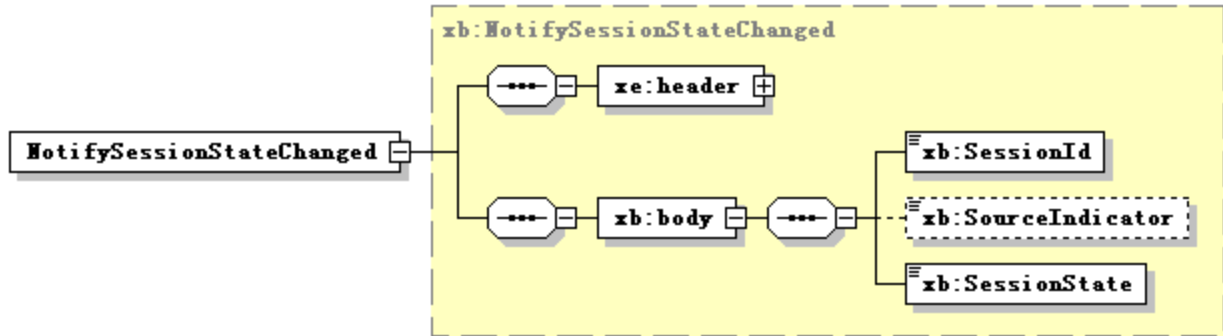

The use of XML schema key word "sequence" to support IS-defined set (not sequence) is for the purpose of XML processor efficiency. This shall not imply the use of "sequence" in other technology.

Annex A (normative): Configuration data file base XML schema (file name "configData.xsd")

The following XML schema configData.xsd is the base schema for configuration data XML files:

```
<?xml version="1.0" encoding="UTF-8"?>

<!--
 3GPP TS 32.615 Bulk CM IRP
 Configuration data file base XML schema
 configData.xsd
-->

<schema
  targetNamespace=
"http://www.3gpp.org/ftp/specs/archive/32_series/32.615#configData"

  elementFormDefault="qualified"

  xmlns="http://www.w3.org/2001/XMLSchema"

  xmlns:xn=
"http://www.3gpp.org/ftp/specs/archive/32_series/32.625#genericNrm"

  xmlns:cn=
"http://www.3gpp.org/ftp/specs/archive/32_series/32.635#coreNrm"

  xmlns:un=
"http://www.3gpp.org/ftp/specs/archive/32_series/32.645#utranNrm"

  xmlns:gn=
"http://www.3gpp.org/ftp/specs/archive/32_series/32.655#geranNrm"

  xmlns:stn=
"http://www.3gpp.org/ftp/specs/archive/32_series/32.745#stnNrm"

  xmlns:in=
"http://www.3gpp.org/ftp/specs/archive/32_series/32.695#inventoryNrm"

  xmlns:tn=
"http://www.3gpp.org/ftp/specs/archive/32_series/32.715#transportNrm"

  xmlns:im=
"http://www.3gpp.org/ftp/specs/archive/32_series/32.735#imsNrm"

  xmlns:rn=
"http://www.3gpp.org/ftp/specs/archive/32_series/32.725#repeaterNrm"

  xmlns:epc=
"http://www.3gpp.org/ftp/specs/archive/32_series/32.755#epcNrm"

  xmlns:en=
"http://www.3gpp.org/ftp/specs/archive/32_series/32.765#eutranNrm"

  xmlns:sp=
"http://www.3gpp.org/ftp/specs/archive/32_series/32.525#sonPolicyNrm"

  xmlns:sn=
"http://www.3gpp.org/ftp/specs/archive/32_series/32.175#sumNrm"

  xmlns:hn=
"http://www.3gpp.org/ftp/specs/archive/32_series/32.775#hnsNrm"

  xmlns:hen=
"http://www.3gpp.org/ftp/specs/archive/32_series/32.785#hensNrm"
>

  <import
    namespace=
```

```

"http://www.3gpp.org/ftp/specs/archive/32_series/32.625#genericNrm"
  />
  <import
    namespace=
"http://www.3gpp.org/ftp/specs/archive/32_series/32.635#coreNrm"
  />
  <import
    namespace=
"http://www.3gpp.org/ftp/specs/archive/32_series/32.645#utranNrm"
  />
  <import
    namespace=
"http://www.3gpp.org/ftp/specs/archive/32_series/32.655#geranNrm"
  />
  <import
    namespace=
"http://www.3gpp.org/ftp/specs/archive/32_series/32.745#stnNrm"
  />
  <import
    namespace=
"http://www.3gpp.org/ftp/specs/archive/32_series/32.695#inventoryNrm"
  />
  <import
    namespace=
"http://www.3gpp.org/ftp/specs/archive/32_series/32.715#transportNrm"
  />
  <import
    namespace=
"http://www.3gpp.org/ftp/specs/archive/32_series/32.735#imsNrm"  />
  <import
    namespace=
"http://www.3gpp.org/ftp/specs/archive/32_series/32.725#repeaterNrm"
  />
  <import
    namespace=
"http://www.3gpp.org/ftp/specs/archive/32_series/32.755#epcNrm"
  />
  <import
    namespace=
"http://www.3gpp.org/ftp/specs/archive/32_series/32.765#eutranNrm"
  />
  <import
    namespace=
"http://www.3gpp.org/ftp/specs/archive/32_series/32.525#sonPolicyNrm"
  />

  <import
    namespace=
"http://www.3gpp.org/ftp/specs/archive/32_series/32.175#sumNrm"
  />

  <import
    namespace=
"http://www.3gpp.org/ftp/specs/archive/32_series/32.725#repeaterNrm"
  />

  <import
    namespace=
"http://www.3gpp.org/ftp/specs/archive/32_series/32.775#hnsNrm"
  />

  <import
    namespace=
"http://www.3gpp.org/ftp/specs/archive/32_series/32.785#hensNrm"
  />

<!-- Configuration data file root XML element -->
<element name="bulkCmConfigDataFile">
  <complexType>
    <sequence>
      <element name="fileHeader">
        <complexType>
          <attribute name="fileFormatVersion" type="string" use="required"/>
          <attribute name="senderName" type="string" use="optional"/>
          <attribute name="vendorName" type="string" use="optional"/>
        </complexType>
      </element>
    </sequence>
  </complexType>
</element>

```

```
</element>
<element name="configData" maxOccurs="unbounded">
  <complexType>
    <choice>
      <element ref="xn:SubNetwork"/>
      <element ref="xn:MeContext"/>
      <element ref="xn:ManagedElement"/>
    </choice>
    <attribute name="dnPrefix" type="string" use="optional"/>
  </complexType>
</element>
<element name="fileFooter">
  <complexType>
    <attribute name="dateTime" type="dateTime" use="required"/>
  </complexType>
</element>
</sequence>
</complexType>
</element>
</schema>
```

Annex B (normative):
Void

Annex C (informative): Configuration data file vendor-specific XML schema example

The following XML schema is an example of vendor-specific schema for configuration data XML files:

```
<?xml version="1.0" encoding="UTF-8"?>

<!--
  Configuration data file vendor-specific XML schema example
  NNRncHandOver.1.1.xsd
-->

<schema
  targetNamespace="http://www.companyNN.com/xmlschemas/NNRncHandOver.1.1"
  elementFormDefault="qualified"
  xmlns="http://www.w3.org/2001/XMLSchema"
  xmlns:xn=
"http://www.3gpp.org/ftp/specs/archive/32_series/32.625#genericNrm"
>

  <import
    namespace=
"http://www.3gpp.org/ftp/specs/archive/32_series/32.625#genericNrm"
    />

  <!-- RncHandOver version 1.1 company NN vendor-specific data -->

  <element name="vsDataRHO" substitutionGroup="xn:vsData">
    <complexType>
      <complexContent>
        <extension base="xn:vsData">
          <all>
            <element name="abcMin" minOccurs="0"/>
            <element name="abcMax" minOccurs="0"/>
          </all>
        </extension>
      </complexContent>
    </complexType>
  </element>

</schema>
```

Annex D (normative): Session log file XML schema (file name "sessionLog.xsd")

The following XML schema sessionLog.xsd is the schema for session log XML files:

```
<?xml version="1.0" encoding="UTF-8"?>

<!--
  3GPP TS 32.615 Bulk CM IRP
  Session log file XML schema
  sessionLog.xsd
-->

<schema
  targetNamespace=
"http://www.3gpp.org/ftp/specs/archive/32_series/32.615#sessionLog"
  elementFormDefault="qualified"
  xmlns="http://www.w3.org/2001/XMLSchema"
>

  <!-- Session log file root XML element -->

  <element name="bulkCmSessionLogFile">
    <complexType>
      <sequence>
        <element name="fileHeader">
          <complexType>
            <attribute name="fileFormatVersion" type="string" use="required"/>
            <attribute name="senderName" type="string" use="optional"/>
            <attribute name="vendorName" type="string" use="optional"/>
          </complexType>
        </element>
        <element name="activity" minOccurs="0" maxOccurs="unbounded">
          <complexType>
            <sequence>
              <element name="log" maxOccurs="unbounded">
                <complexType>
                  <simpleContent>
                    <extension base="string">
                      <attribute name="time" type="time" use="required"/>
                      <attribute name="type" use="required">
                        <simpleType>
                          <restriction base="string">
                            <enumeration value="informative"/>
                            <enumeration value="error"/>
                          </restriction>
                        </simpleType>
                      </attribute>
                      <attribute name="dn" type="string" use="optional"/>
                      <attribute name="modifier" use="optional">
                        <simpleType>
                          <restriction base="string">
                            <enumeration value="create"/>
                            <enumeration value="delete"/>
                            <enumeration value="update"/>
                          </restriction>
                        </simpleType>
                      </attribute>
                    </extension>
                  </simpleContent>
                </complexType>
              </element>
            </sequence>
            <attribute name="dateTime" type="dateTime" use="required"/>
            <attribute name="type" use="required">
              <simpleType>
                <restriction base="string">
                  <enumeration value="upload"/>
                  <enumeration value="download"/>
                  <enumeration value="validate"/>
                  <enumeration value="preactivate"/>
                </restriction>
              </simpleType>
            </attribute>
          </complexType>
        </element>
      </sequence>
    </complexType>
  </element>

```

```
        <enumeration value="activate"/>
        <enumeration value="fallback"/>
      </restriction>
    </simpleType>
  </attribute>
</complexType>
</element>
<element name="fileFooter">
  <complexType>
    <attribute name="dateTime" type="dateTime" use="required"/>
  </complexType>
</element>
</sequence>
</complexType>
</element>
</schema>
```

Annex E (normative): BulkCMIRP Notification XML schema (file name "bulkCMIRPNotif.xsd")

```

<?xml version="1.0" encoding="UTF-8"?>
<!--
  3GPP TS 32.615 BulkCMIRP Notification XML Schema
  bulkCMIRPNotif.xsd
-->
<schema xmlns:xb="http://www.3gpp.org/ftp/specs/archive/32_series/32.615#bulkCMIRPNotif"
  xmlns:xe="http://www.3gpp.org/ftp/specs/archive/32_series/32.305#notification"
  xmlns="http://www.w3.org/2001/XMLSchema"
  targetNamespace="http://www.3gpp.org/ftp/specs/archive/32_series/32.615#bulkCMIRPNotif"
  elementFormDefault="qualified" attributeFormDefault="unqualified">
  <import namespace="http://www.3gpp.org/ftp/specs/archive/32_series/32.305#notification"/>
  <simpleType name="SessionId">
    <restriction base="string">
      <minLength value="1"/>
    </restriction>
  </simpleType>
  <simpleType name="SourceIndicator">
    <restriction base="string">
      <enumeration value="Resource Operation"/>
      <enumeration value="management Operation"/>
      <enumeration value="unknown"/>
    </restriction>
  </simpleType>
  <simpleType name="SessionState">
    <restriction base="string">
      <enumeration value="Upload Failed"/>
      <enumeration value="Upload Completed"/>
      <enumeration value="Download Failed"/>
      <enumeration value="Download Completed"/>
      <enumeration value="Validation Failed"/>
      <enumeration value="Validation Completed"/>
      <enumeration value="Preactivation Failed"/>
      <enumeration value="Preactivation Partly Realised"/>
      <enumeration value="Preactivation Completed"/>
      <enumeration value="Activation Failed"/>
      <enumeration value="Activation Partly Realised"/>
      <enumeration value="Activation Completed"/>
      <enumeration value="Fallback Failed"/>
      <enumeration value="Fallback Partly Realised"/>
      <enumeration value="Fallback Completed"/>
    </restriction>
  </simpleType>
  <simpleType name="SessionLogStatus">
    <restriction base="string">
      <enumeration value="GetSessionLog completed successfully"/>
      <enumeration value="GetSessionLog completed unsuccessfully"/>
    </restriction>
  </simpleType>
  <complexType name="NotifySessionStateChanged">
    <complexContent>
      <extension base="xe:Notification">
        <sequence>
          <element name="body">
            <complexType>
              <sequence>
                <element name="SessionId" type="xb:SessionId"/>
                <element name="SessionState" type="xb:SessionState"/>
                <element name="SourceIndicator" type="xb:SourceIndicator"/>
              </sequence>
            </complexType>
          </element>
        </sequence>
      </extension>
    </complexContent>
  </complexType>
  <complexType name="NotifyGetSessionLogEnded">
    <complexContent>
      <extension base="xe:Notification">

```



```
<sequence>
  <element name="body">
    <complexType>
      <sequence>
        <element name="SessionId" type="xb:SessionId"/>
        <element name="SessionLogStatus" type="xb:SessionLogStatus"/>
        <element name="SourceIndicator" type="xb:SourceIndicator"
minOccurs="0"/>
      </sequence>
    </complexType>
  </element>
</sequence>
</extension>
</complexContent>
</complexType>
<element name="NotifySessionStateChanged" type="xb:NotifySessionStateChanged"/>
<element name="NotifyGetSessionLogEnded" type="xb:NotifyGetSessionLogEnded"/>
</schema>
```

Annex F (informative):
Void

Annex G (informative): Change history

Change history								
Date	TSG #	TSG Doc.	CR	Rev	Subject/Comment	Cat	Old	New
Dec 2006	SA_34	SP-060730	0026	--	Include IMS NRM IRP in the scope for Bulk CM IRP - Align with 32.612	C	6.3.0	7.0.0
Mar 2007	SA_35	SP-070046	0027	--	Add Notification XML definition in BulkCMIRP	B	7.0.0	7.1.0
Sep 2007	SA_37	SP-070612	0028	--	Add Repeater NRM Namespace	F	7.1.0	7.2.0
Mar 2009	SA_43	SP-090207	0029	--	Include reference to SOAP Solution Set specification	D	7.2.0	8.0.0
Jun 2009	SA_44	SP-090289	0030	--	Include EUTRAN and EPC NRMs in configData.xsd	F	8.0.0	8.1.0
Dec 2009	SA_46	SP-090718	0032	--	Increase the linked IS version by the CR for IS to clarify scope parameters for upload operation	F	8.1.0	8.2.0
Dec 2009	SA_46	SP-090719	0031	--	Discontinue from Rel-9 onwards the XML schema extraction and storage	F	8.2.0	9.0.0
Jun 2010	SA_48	SP-100412	0033	--	Corrections to Bulk CM IRP XML	F	9.0.0	9.1.0
Dec 2010	SA_50	SP-100858	0034	1	Correcting the Bulk CM IRP XML schema - Align with 32.612 IS	F	9.1.0	9.2.0