

3GPP TS 32.541 V11.0.0 (2012-09)

Technical Specification

**3rd Generation Partnership Project;
Technical Specification Group Services and System Aspects;
Telecommunication management;
Self-Organizing Networks (SON);
Self-healing concepts and requirements
(Release 11)**



The present document has been developed within the 3rd Generation Partnership Project (3GPPTM) and may be further elaborated for the purposes of 3GPP.

The present document has not been subject to any approval process by the 3GPP Organizational Partners and shall not be implemented. This Specification is provided for future development work within 3GPP only. The Organizational Partners accept no liability for any use of this Specification. Specifications and reports for implementation of the 3GPPTM system should be obtained via the 3GPP Organizational Partners' Publications Offices.

Keywords

SON, Self-Healing, management

3GPP

Postal address

3GPP support office address

650 Route des Lucioles - Sophia Antipolis
Valbonne - FRANCE
Tel.: +33 4 92 94 42 00 Fax: +33 4 93 65 47 16

Internet

<http://www.3gpp.org>

Copyright Notification

No part may be reproduced except as authorized by written permission.
The copyright and the foregoing restriction extend to reproduction in all media.

© 2012, 3GPP Organizational Partners (ARIB, ATIS, CCSA, ETSI, TTA, TTC).
All rights reserved.

UMTS™ is a Trade Mark of ETSI registered for the benefit of its members
3GPP™ is a Trade Mark of ETSI registered for the benefit of its Members and of the 3GPP Organizational Partners
LTE™ is a Trade Mark of ETSI currently being registered for the benefit of its Members and of the 3GPP Organizational Partners
GSM® and the GSM logo are registered and owned by the GSM Association

Contents

Foreword	5
Introduction	5
1 Scope	6
2 References.....	6
3 Definitions and abbreviations	6
3.1 Definitions	6
3.2 Abbreviations.....	7
4 Concepts and background	7
4.1 Overview	7
4.1.1 General description	7
4.1.2 Recovery actions	8
4.1.3 General Self-healing procedure	8
4.2 Self-healing Concept.....	11
4.2.1 Logical Function Blocks	11
4.2.1.1 Self-healing Input Monitoring Function (SH_MON_F).....	11
4.2.1.2 Self-healing Diagnosis Function (SH_DG_F)	11
4.2.1.3 Triggering Recovery Action/s Function (SH_TG_F).....	11
4.2.1.4 Self-healing Evaluating Function (SH_EV_F)	11
4.2.1.5 Self-healing Fallback Function (SH_FB_F)	11
4.2.1.6 NRM IRP Update Function (NRM_UF).....	11
4.2.1.7 Self-healing Monitoring and Management Function (SH_MMF)	11
4.2.1.7.1 Self-healing Monitoring and Management Function (SH_MMF_NM)	11
4.2.1.7.2 Self-healing Monitoring and Management Function (SH_MMF_EM)	11
4.2.1.8 Self-healing of Cell Outage Function (SH_CO_F)	11
4.2.1.9 Self Recovery of NE software Function (SR_NSW_F)	11
4.2.1.10 Self-healing of Board Fault Function (SH_BF_F)	11
5 Business level requirements	12
5.1 Requirements.....	12
5.2 Actor roles	12
5.3 Telecommunications Resources.....	12
5.4 High-Level use case.....	13
5.4.1 Alarm Triggered Self-healing	13
5.4.2 Cell outage scenarios.....	13
6 Specification level requirements	14
6.1 Requirements.....	14
6.1.1 Monitoring and Management part.....	14
6.1.2 Self-healing of Cell Outage Function	14
6.2 Actor roles	15
6.3 Telecommunications Resources.....	15
6.4 Use case.....	15
6.4.1 Self Recovery of NE Software.....	15
6.4.2 Self-healing of board faults	16
6.4.3 Self Healing of Cell Outage	17
6.4.3.1 Use case Cell Outage Detection	17
6.4.3.2 Use case Cell Outage Recovery	17
6.4.3.3 Use case Cell Outage Compensation.....	18
6.4.3.4 Use case Return from Cell Outage Compensation.....	18
7 Functions and Architecture	19
7.1 Self-healing Logical Architecture.....	19
7.2 Self-healing Reference Model.....	20

Annex A (informative): Change history.....21

Foreword

This Technical Specification has been produced by the 3rd Generation Partnership Project (3GPP).

The contents of the present document are subject to continuing work within the TSG and may change following formal TSG approval. Should the TSG modify the contents of the present document, it will be re-released by the TSG with an identifying change of release date and an increase in version number as follows:

Version x.y.z

where:

- x the first digit:
 - 1 presented to TSG for information;
 - 2 presented to TSG for approval;
 - 3 or greater indicates TSG approved document under change control.
- y the second digit is incremented for all changes of substance, i.e. technical enhancements, corrections, updates, etc.
- z the third digit is incremented when editorial only changes have been incorporated in the document.

Introduction

The present document is part of a TS-family covering the 3rd Generation Partnership Project Technical Specification Group Services and System Aspects, Telecommunication management; as identified below:

32.541: “Self-Organizing Networks (SON); Self-Healing Concepts and Requirements”

Stage 2 for Self-Healing is not in a TS of its own. Stage 2 for selected Self-Healing functions is or will be part of 32.522 [6] and 32.762 [7].

1 Scope

The present document describes concept and requirements of OAM for Self-Healing of Self-Organizing Networks (SON).

2 References

The following documents contain provisions which, through reference in this text, constitute provisions of the present document.

- References are either specific (identified by date of publication, edition number, version number, etc.) or non-specific.
- For a specific reference, subsequent revisions do not apply.
- For a non-specific reference, the latest version applies. In the case of a reference to a 3GPP document (including a GSM document), a non-specific reference implicitly refers to the latest version of that document *in the same Release as the present document*.

- [1]. 3GPP TS 32.101: "Telecommunication management; Principles and high level requirements".
- [2]. 3GPP TS 32.102: "Telecommunication management; Architecture".
- [3]. 3GPP TS 32.111-1: "Telecommunication management; Fault Management; Part 1: 3G fault management requirements".
- [4]. 3GPP TS 32.301: "Telecommunication management; Configuration Management (CM); Notification Integration Reference Point (IRP): Requirements".
- [5]. 3GPP TR 21.905: "Vocabulary for 3GPP Specifications".
- [6]. 3GPP TS 32.522: "Telecommunication management; Self-Organizing Networks (SON) Policy Network Resource Model (NRM) Integration Reference Point (IRP); Information Service (IS)".
- [7]. 3GPP TS 32.762: "Telecommunication management; Evolved Universal Terrestrial Radio Access Network (E-UTRAN) Network Resource Model (NRM) Integration Reference Point (IRP); Information Service (IS)".

3 Definitions and abbreviations

3.1 Definitions

For the purposes of the present document, the terms and definitions given in TR 21.905 [5] and the following apply. A term defined in the present document takes precedence over the definition of the same term, if any, in TR 21.905 [5].

alarm: See 3GPP TS 32.111-1 [3].

Cell Outage: Cell outage is the total loss of radio services in the coverage area of a cell.

fault: See 3GPP TS 32.111-1 [3].

Stop condition: The Self-healing procedure may include one or more iterations until the related fault is resolved or the thresholds of some parameters (e.g. iteration counter or iteration duration time, etc.) are reached. These thresholds may be used to determine whether to stop the procedure if the related fault is still not resolved after several iterations or a long time. We call these thresholds as well as fault resolution the stop conditions.

Self-healing Process: When a TCoSH is reached, particular action(s) will be triggered to solve or mitigate the particular fault.

Self-healing Function: a Self-healing Function is to monitor a particular TCoSH and then, if necessary, to trigger a Self-healing Process to solve or mitigate the particular fault.

Trigger Condition of Self-Healing (TCoSH): it is the condition which is used to judge whether a Self-healing Process needs to be started. This condition could be an alarm or the detection of a fault.

3.2 Abbreviations

For the purposes of the present document, the abbreviations given in TR 21.905 [5] and the following apply. An abbreviation defined in the present document takes precedence over the definition of the same abbreviation, if any, in TR 21.905 [5].

ADAC	Automatically Detected and Automatically Cleared
ADMC	Automatically Detected and Manually Cleared
EM	Element Manager
EPC	Evolved Packet Core
E-UTRAN	Evolved Universal Terrestrial Radio Access Network
NE	Network Element
NM	Network Manager
OAM	Operation Administration Maintenance
SON	Self Organizing Networks
TCoSH	Trigger Condition of Self-Healing
UE	User Equipment

4 Concepts and background

4.1 Overview

4.1.1 General description

Self-healing is a functionality of SON. The purpose of Self-healing is to solve or mitigate the faults which could be solved automatically by triggering appropriate recovery actions.

From the point of view of fault management, for each detected fault, appropriate alarms shall be generated by the faulty network entity, regardless of whether it is an ADAC or an ADMC fault.

The trigger of Self-healing can be an alarm. In this case, the Self-healing functionality monitors the alarms, and when it finds alarm/s which could be solved automatically, it gathers more necessary information (e.g. measurements, testing result, etc) and does deep analysis, and then according to the analysis result, if necessary, it triggers appropriate recovery actions to solve the fault automatically.

For some Self-healing functions which are located in NEs and require more rapid response, the trigger of Self-healing can be the detection of a fault. Hence, when a fault is detected, an appropriate Self-healing Process will be triggered to try to heal the fault automatically.

The Self-healing functionality also monitors the execution of the recovery action/s and decides the next step accordingly. After a Self-healing procedure ended, the Self-healing functionality shall generate and forward appropriate notifications to inform the IRPManager about the Self-healing result and all the information of the performed recovery actions may be logged.

4.1.2 Recovery actions

In the case of software faults, the recovery actions may be :

- a) system initializations (at different levels),
- b) reload of a backup of software,
- c) activation of a fallback software load,
- d) download of a software unit,
- e) reconfiguration, etc.

In the case of hardware faults, the recovery actions depend on the existence and type of redundant (i.e. back-up) resources.

If the faulty resource has no redundancy, the recovery actions may be:

- a) Isolate and remove the faulty resource from service so that it does not disturb other working resources;
- b) Remove the physical and functional resources (if any) from the service, which are dependent on the faulty one. This prevents the propagation of the fault effects to other fault-free resources;
- c) State management related activities for the faulty resource and other affected/dependent resources;
- d) Reset the faulty resource;
- e) Other reconfiguration actions, etc.

If the faulty resource has redundancy, the recovery action shall be changeover, which includes the action a), c) and d) above and a specific recovery sequence. The detail of the specific recovery sequence is out of the scope of the present document.

In the case of other kinds of faults, the recovery actions are FFS.

4.1.3 General Self-healing procedure

The Self-healing Function has two parts: the monitoring part and the healing process part. The logic view of the general Self-healing procedure is shown in figure 4.1.3-1:

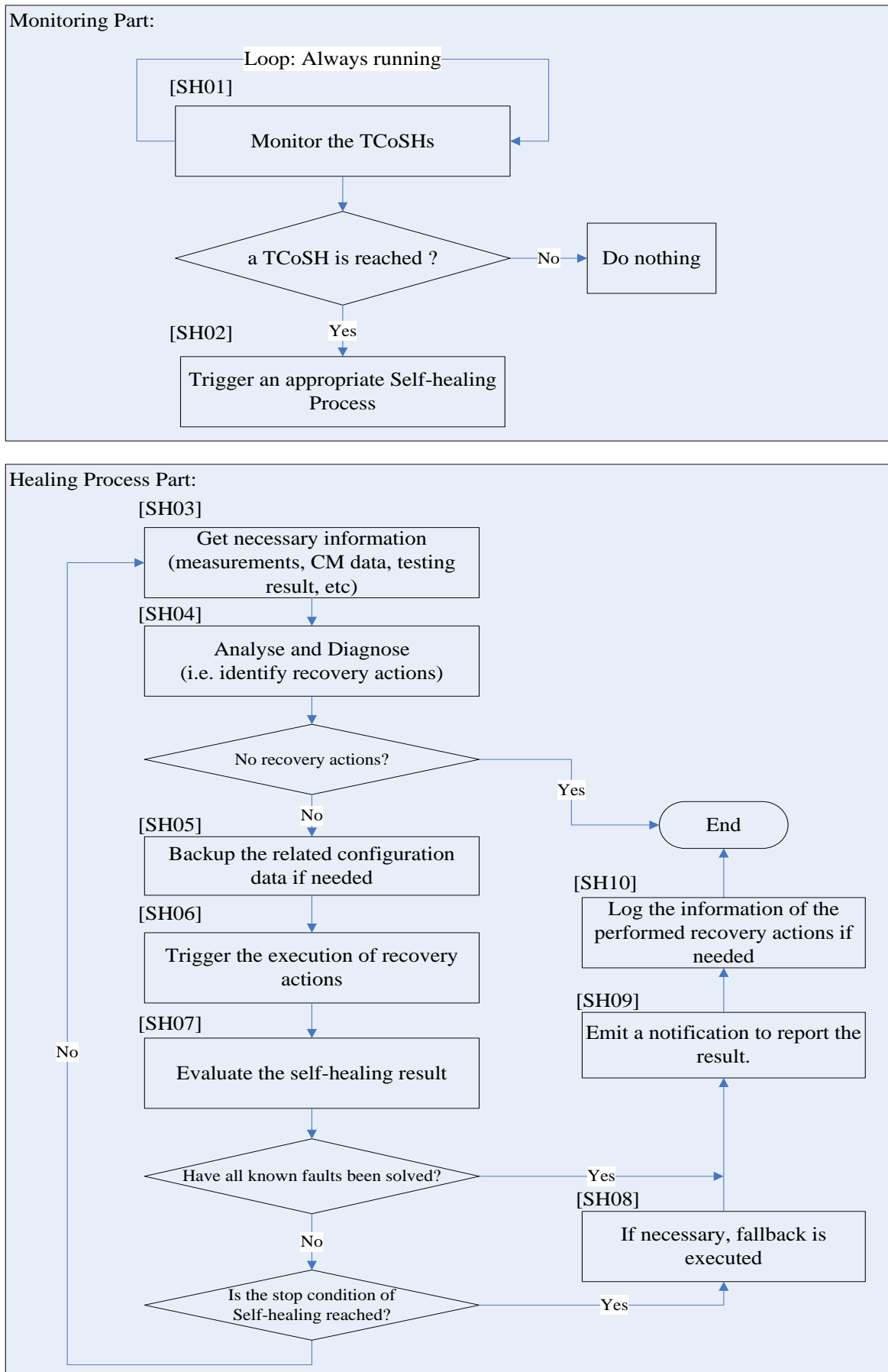

Figure 4.1.3-1: logic view of the general Self-healing procedure

The general Self-healing procedure includes following steps:

[Monitoring part:]

[SH01]The Self-healing Function monitors the TCoSHs continuously.

[SH02]When a TCoSH is reached, then an appropriate Self-healing Process shall be triggered.

[Healing process part:]

[SH03]The Self-healing Function gathers more necessary information (e.g. measurements, CM data, testing result, etc).

[SH04]Based on the TCoSH and gathered information, the Self-healing Function does deep analysis and diagnosis, and gives the result. If the result includes recovery action/s, then go to next step, if not, go to End.

[SH05] The configuration data prior to the executing of the recovery action/s is backed up if needed.

[SH06]If necessary, the Self-healing Function triggers the executing of the recovery action/s.

[SH07] The Self-healing Function evaluates the result of the self-healing recovery action/s:

If the fault hasn't been solved and the stop condition/s is not reached, then the self-healing runs again, i.e. go to SH03.

If the fault has been solved, then go to [SH09].

If the stop condition/s is reached, then:

[SH08] If necessary, fallback is executed. Go to [SH09].

[SH09] The Self-healing Function emits a notification to report the result of the Self-healing Process.

[SH10] If necessary, the Self-healing Function logs the information of the performed recovery actions and the occurrence of important events during the self-healing process.

Remark: The detailed healing process part of the individual self-healing use cases may differ from this general description, for example:

- 1) The order of the bullet points in the list does not imply any statement on the order of execution.
- 2) In [SH05], whether the backup of the configuration data is needed and which configuration data should be backed up shall be decided on a use case by use case basis.
- 3) In [SH08], whether a fallback is needed shall be decided on a use case by use case basis.
- 4) In [SH10], whether log is needed and the detail of the logged information shall be decided on a use case by use case basis.

4.2 Self-healing Concept

4.2.1 Logical Function Blocks

4.2.1.1 Self-healing Input Monitoring Function (SH_MON_F)

This functional block supports the following steps: [SH01], [SH02] (See clause 4.1.3).

4.2.1.2 Self-healing Diagnosis Function (SH_DG_F)

This functional block supports the following step: [SH04] (See clause 4.1.3).

4.2.1.3 Triggering Recovery Action/s Function (SH_TG_F)

This functional block supports the following step: [SH06] (See clause 4.1.3).

4.2.1.4 Self-healing Evaluating Function (SH_EV_F)

This functional block supports the following step: [SH07] (See clause 4.1.3).

4.1.2.5 Self-healing Fallback Function (SH_FB_F)

This functional block supports the following step: [SH08] (See clause 4.1.3).

4.2.1.6 NRM IRP Update Function (NRM_UF)

This function updates the E-UTRAN and EPC NRM IRP with the self-healing modification, if needed.

4.2.1.7 Self-healing Monitoring and Management Function (SH_MMF)

Editor's note: This functional block supports the following functions: FFS.

This function monitors the self-healing process and provides the operator with the necessary information of the self-healing process. This function shall be able to get information about all other functional blocks. In addition to this, it allows the operator to control the execution of the self-healing process.

4.2.1.7.1 Self-healing Monitoring and Management Function (SH_MMF_NM)

SH_MMF_NM (IRP Manager): representing the NM portion of SH_MMF (necessary monitoring and limited interaction capabilities to support a self-healing process), as well as related IRPManager functionality.

4.2.1.7.2 Self-healing Monitoring and Management Function (SH_MMF_EM)

SH_MMF_EM (IRP Agent): representing the portion of SH_MMF operating below Itf-N, as well as related IRPAgent functionality.

4.2.1.8 Self-healing of Cell Outage Function (SH_CO_F)

This function handles the self-healing function for cell outage.

4.2.1.9 Self Recovery of NE software Function (SR_NSW_F)

This function handles the self-healing function of recovery of NE software.

4.2.1.10 Self-healing of Board Fault Function (SH_BF_F)

This function handles the self-healing function for board fault.

5 Business level requirements

5.1 Requirements

REQ_SH_CON_001 It should be possible for the self-healing actions to be confirmed by the IRPManager before they are executed.

REQ_SH_CON_002 The Self-healing functionality shall be performed with minimal human intervention.

REQ-SH-CON-003 The IRPAgent shall support a capability allowing the IRPManager to know the success or failure result of Self-healing.

REQ-SH-CON-004 The IRPAgent should support a capability allowing the IRPManager to monitor the self-healing actions.

REQ-SH-CON-005 The self-healing complex corrective actions shall be executed in a consistent and coordinated way.

REQ-SH-CON-006 The IRPAgent or eNB should perform the necessary reconfigurations during a cell outage. If that is not or only partly possible or not supported, then the IRPAgent should indicate the need for assistance to the IRPManager.

REQ_SH_CON_007 The IRPAgent shall support a capability allowing the IRPManager to know which alarms are associated with a self-healing operation, which is in progress.

5.2 Actor roles

5.3 Telecommunications Resources

5.4 High-Level use case

5.4.1 Alarm Triggered Self-healing

Use Case Stage	Evolution / Specification	<<Uses>> Related use
Goal (*)	In the OAM system, the alarms are monitored in real-time. When an alarm which can be self-healed is raised, it is treated as the trigger of the Self-healing and the gathering of correlated information. By gathering the correlated information and further analysis, the self-healing actions of the fault shall be triggered.	
Actors and Roles (*)	Self-healing function, IRPManager	
Telecom resources	The E-UTRAN/EPC network including its OSS.	
Assumptions	The network is properly installed and running.	
Pre conditions	Network is in normal operation.	
Begins when	Automatically triggered when an alarm received, the alarm may be emitted by NE or OAM system.	
Step 1 (*) (M)	The Self-healing functionality monitors the alarms, and when it finds alarm/s which can be solved automatically, goes to step 2.	
Step 2 (*) (M)	It gathers more necessary information (e.g. measurements, CM data, testing result, etc).	
Step 3 (*) (M)	Based on the alarm and gathered information, it does deep analysis and diagnosis, and may give the result, i.e. recovery actions.	
Step 4 (*) (M)	If necessary, it triggers appropriate recovery actions to solve the fault automatically.	
Step 5 (*) (M)	It evaluates the result of self-healing: If the fault hasn't been solved and the stop condition/s is not reached, then the self-healing runs again.	
Ends when (*)	Ends when it finds that the fault has been solved or it finds that the recovery is failed or the result of step 3 gives no recovery action or when an exception occurs.	
Exceptions	FFS.	
Post Conditions	If the fault has been solved, then the alarm is disappeared. A notification is raised to report the Self-healing result, and the information of the performed recovery actions is logged.	
Traceability (*)		

5.4.2 Cell outage scenarios

1. Loss of total radio services in the coverage area of a cell

In this scenario, when there is a loss of total radio services in the outage cell, all the UEs cannot establish or maintain all the Radio Bearers (RBs) via that particular cell. For example, all the Cell Center Users (CCU) and Cell Edge Users (CEU) cannot establish the RRC connection in the outage Cell A.

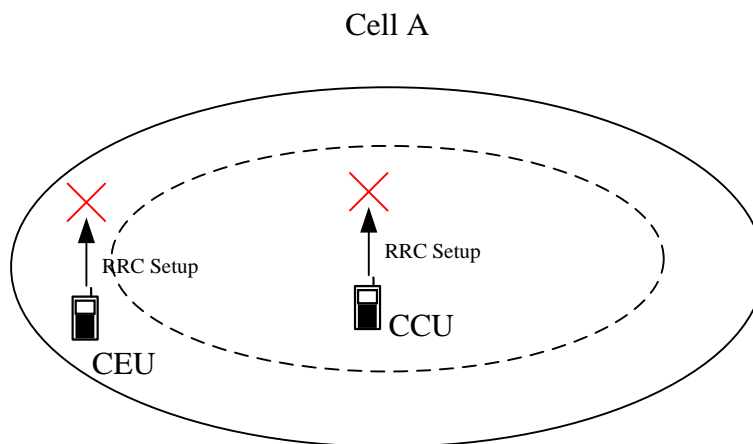

Figure 5.4.2-1: Loss of total radio services in the coverage area of a cell

6 Specification level requirements

6.1 Requirements

6.1.1 Monitoring and Management part

REQ_SH_FUN_001 The IRPAgent should provide information to the IRPManager about the self-healing actions. The specific activities to be reported to the IRPManager by each Self-Healing function will be determined on a use case by use case basis.

REQ_SH_FUN_002 The IRPAgent shall provide information to the IRPManager about the self-healing results.

REQ_SH_FUN_003 The IRPAgent shall support a capability allowing the IRPManager to enable and disable the self-healing functionalities on a use case by use case basis.

REQ-SH-FUN-004 The IRPAgent shall support a capability allowing the IRPManager to get the information (e.g. a list) of the supported Self-healing Functions on a use case by use case basis.

REQ-SH-FUN-005 The IRPAgent shall support a capability allowing the IRPManager to get the status (enabled or disabled) of the Self-healing Functions on a use case by use case basis.

REQ-SH-FUN-006 The IRPAgent shall support a capability allowing the IRPManager to be notified (according to TS 32.301 [4]) of the start and end of Self-healing action on a use case by use case basis.

REQ-SH-FUN-007 The IRP Agent shall provide information to the IRP Manager that allows the IRP Manager to identify which alarms are associated with a self healing operation which is in progress on a use case by use case basis.

6.1.2 Self-healing of Cell Outage Function

REQ_SHCOC_FUN_1

The IRPAgent shall inform the IRPManager about begin and end of a cell outage compensation.

REQ_SHCOC_FUN_2

The IRPAgent should provide the IRPManager the possibility to know the result of a cell outage recovery.

REQ_SHCOC_FUN_3

The IRPAgent shall provide the IRPManager the possibility to know the result of a cell outage compensation.

REQ_SHCOC_FUN_4

The IRPAgent should provide the IRPManager the possibility to define which cells are allowed or prohibited to be reconfigured for cell outage compensation.

6.2 Actor roles

6.3 Telecommunications Resources

6.4 Use case

6.4.1 Self Recovery of NE Software

Use Case Stage	Evolution / Specification	<<Uses>> Related use
Goal (*)	The NE software is recovered to the initial status or the status of latest backup, to ensure the NE software runs normally.	
Actors and Roles (*)	IRPManager and Self-healing function	
Telecom resources	The E-UTRAN/EPC network including its OSS.	
Assumptions	The network is properly installed and running.	
Pre conditions	The operator has the initial backup or the latest backup of the NE software and configuration data. The NE Software Self Recovery function is started. The monitoring part of the NE Software Self Recovery function monitors the TCoSH continuously.	
Begins when	A TCoSH of this function is detected.	
Step 1 (*) (M)	Self-healing Process of the NE Software Self Recovery is triggered to heal the fault : Verify the version of software, if it is found that the software is destroyed, restore the backup of the destroyed software. Check the configuration data, if it is found that the configuration data is incorrect, reconfigure or restore the configuration data. If necessary, restart the process. If it is still abnormal after the healing procedure, a notification shall be raised to notify the IRPManager.	
Ends when (*)	Ends when all steps identified above are completed or when an exception occurs.	
Exceptions	FFS.	
Post Conditions	The NE software is running normally or the operator processes the problem manually.	
Traceability (*)		

This use case is typically covered by existing functionality in most products. No additional specification requirements are identified.

6.4.2 Self-healing of board faults

Use Case Stage	Evolution / Specification	<<Uses>> Related use
Goal (*)	System detects board faults and mitigates or solves them automatically to avoid user impact (E.g. system switch to standby board automatically when active board malfunctions).	
Actors and Roles (*)	IRPManager and Self-healing Function	
Telecom resources	The E-UTRAN/EPC network including its OSS.	
Assumptions	The network is properly installed and running.	
Pre conditions	Network is in normal operation. The board faults Self-healing function is started. The monitoring part of the board faults Self-healing function monitors the TCoSH continuously.	
Begins when	A TCoSH of this function is detected.	
Step 2 (*) (M)	Self-healing Process of this function is triggered to heal the fault : A) The Self-healing functionality collects the redundant information of the faulty board, and processes accordingly: <ul style="list-style-type: none"> • If there is a stand-by board and the stand-by board is in operational state, then the failed board will be blocked and a changeover will be started automatically. Reset the blocked board, if it turns to normal, then it treated as the redundant board. • If there is not a redundant board or the redundant board is in abnormal state, then the failed board will be blocked. B) A notification shall be raised to notify the IRPManager about the healing result.	
Ends when (*)	Ends when all steps identified above are completed or when an exception occurs.	
Exceptions	FFS.	
Post Conditions	The device is running normally or the operator processes the problem manually.	
Traceability (*)		

This use case is typically covered by existing functionality in most products. No additional specification requirements are identified.

6.4.3 Self Healing of Cell Outage

6.4.3.1 Use case Cell Outage Detection

Use Case Stage	Evolution / Specification	<<Uses>> Related use
Goal (*)	System detects a cell outage (e.g. sleeping, out-of-service, etc.) automatically.	
Actors and Roles (*)	IRPManager as user	
Telecom resources	The E-UTRAN/EPC network including its OSS.	
Assumptions	N/A	
Pre conditions	The network is properly installed and running.	
Begins when	N/A	
Step 1 (*) (M)	The input parameters (KPIs, alarms, etc.) are monitored continuously by cell outage detection function.	
Step 2 (*) (M)	When the monitored parameters meet the cell outage detection condition, e.g. when there is a cell outage related alarm or the value of one KPI crossed the threshold, the cell outage is detected.	
Step 3 (*) (O)	IRPManager got information about the cell outage.	
Ends when (*)	Ends when all steps identified above are completed or when an exception occurs.	
Exceptions	One of the steps identified above fails and retry is unsuccessful.	
Post Conditions	In case of success of step 1 and step 2: Cell outage is detected. In case of exception in step 1 or step 2: Cell outage is not detected.	
Traceability (*)	FFS	

6.4.3.2 Use case Cell Outage Recovery

Use Case Stage	Evolution / Specification	<<Uses>> Related use
Goal	System recovers a cell outage (e.g. sleeping, out-of-service, etc.) automatically	
Actors and Roles	Cell outage recovery function, IRPManager	
Telecom resources	The E-UTRAN/EPC network including its Management Systems.	
Assumptions	The network is properly installed and running.	
Pre conditions	A cell-outage was detected.	
Begins when	Information about cell-outage is available to Cell Outage recovery function.	
Step 1 (M)	Try recovery action/s (examples: switch to redundant hardware if the fault is caused by malfunction of redundant entity, re-establish or re-configure the cell, software restart etc.)	
Step 2 (O)	Reporting of the Cell Outage Recovery results to the IRP Manager	
Ends when	Ends when all steps identified above are completed or when an exception occurs.	
Exceptions	Recovery action/s is/are not successful.	
Post Conditions	In case of success: Cell outage ended. In case of exception: Cell outage persists	
Traceability		

6.4.3.3 Use case Cell Outage Compensation

Use Case Stage	Evolution / Specification	<<Uses>> Related use
Goal	System compensates a cell outage (e.g. sleeping, out-of-service, etc.) automatically to maintain as much as possible normal services to the network users	
Actors and Roles	IRPManager	
Telecom resources	The E-UTRAN/EPC network including its Management Systems.	
Assumptions	The network is properly installed and running. Optional assumption: IRPManager is continuously aware about configuration information and other relevant data in order to support an efficient and effective re-configuration when a compensated cell outage ends.	
Pre conditions	A cell-outage was detected and is still ongoing. Cell-outage recovery – if attempted – was not yet successful.	
Begins when	Cell outage compensation function (COCF) is informed about a detected cell-outage.	
Step 1 (CO)	Current configuration information and other relevant data are gathered in order to support an efficient and effective re-configuration when a compensated cell outage ends. Remark: Depending on the type of outage some configuration information may not be available. Condition: Continuous awareness of configuration information (see optional assumption above) is not there.	
Step 2 (M)	Reconfiguration of related neighbouring eNBs to compensate the cell outage.	
Step 3 (O)	Make changed configuration which was done for the Cell Outage Compensation (see step 2) available to the IRP Manager	
Ends when	Ends when all steps identified above are completed or when an exception occurs.	
Exceptions	One of the steps identified above fails and retry is unsuccessful.	
Post Conditions	Impact of cell outage on end user experience is minimized.	
Traceability		

6.4.3.4 Use case Return from Cell Outage Compensation

Use Case Stage	Evolution / Specification	<<Uses>> Related use
Goal	System returns to normal operation after a cell outage compensation	
Actors and Roles	IRPManager	
Telecom resources	The E-UTRAN/EPC network including its Management Systems.	
Assumptions	The network is properly installed and running. Optional assumption: IRPManager is continuously aware of configuration information and other relevant data in order to support an efficient and effective re-configuration when a compensated cell outage ends	
Pre conditions	Cell outage compensation is applied.	
Begins when	End of cell-outage is announced to the COCF.	
Step 1 (M)	System checks if a cell outage compensation was done for the ended cell outage.	
Step 2 (CO)	Current configuration information and other relevant data are gathered in order to support an efficient and effective re-configuration. Condition: Continuous awareness of configuration information (see optional assumption above) is not there.	
Step 3 (M)	Reconfiguration of related neighbouring eNBs and formerly failed cell to remove compensation of the cell outage. This should lead to the same configuration as before the cell outage in case the configuration itself was not the reason for the cell outage and in case the cell neighbourhood, topology did not change since the beginning of the cell outage.	
Step 4 (O)	Make changed configuration after the Cell Outage available to the IRP Manager	
Exceptions	One of the steps identified above fails and retry is unsuccessful.	
Post Conditions	The involved cells are re-configured.	
Traceability		

7 Functions and Architecture

7.1 Self-healing Logical Architecture

The lines between the functional blocks do not indicate specific 3GPP interfaces.

For the abbreviations used, please see the headlines of clause 4.

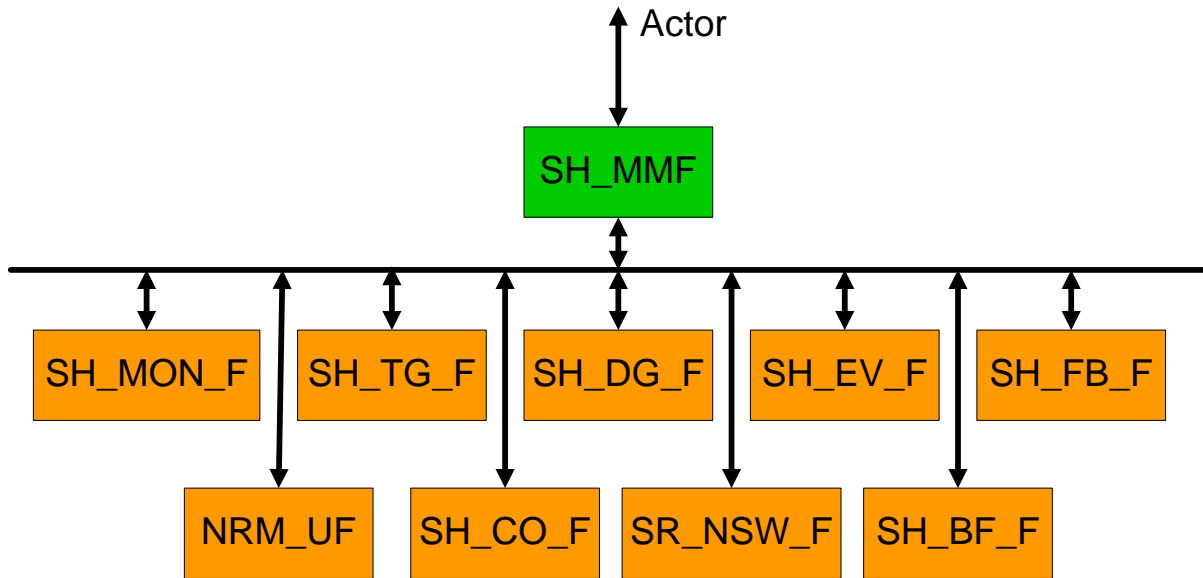

Figure 7.1-1: Self-healing Logical Architecture

7.2 Self-healing Reference Model

The SH_MMF has a part located in the EM and a part located at the NM.

For the abbreviations used, please refer to clause 4.

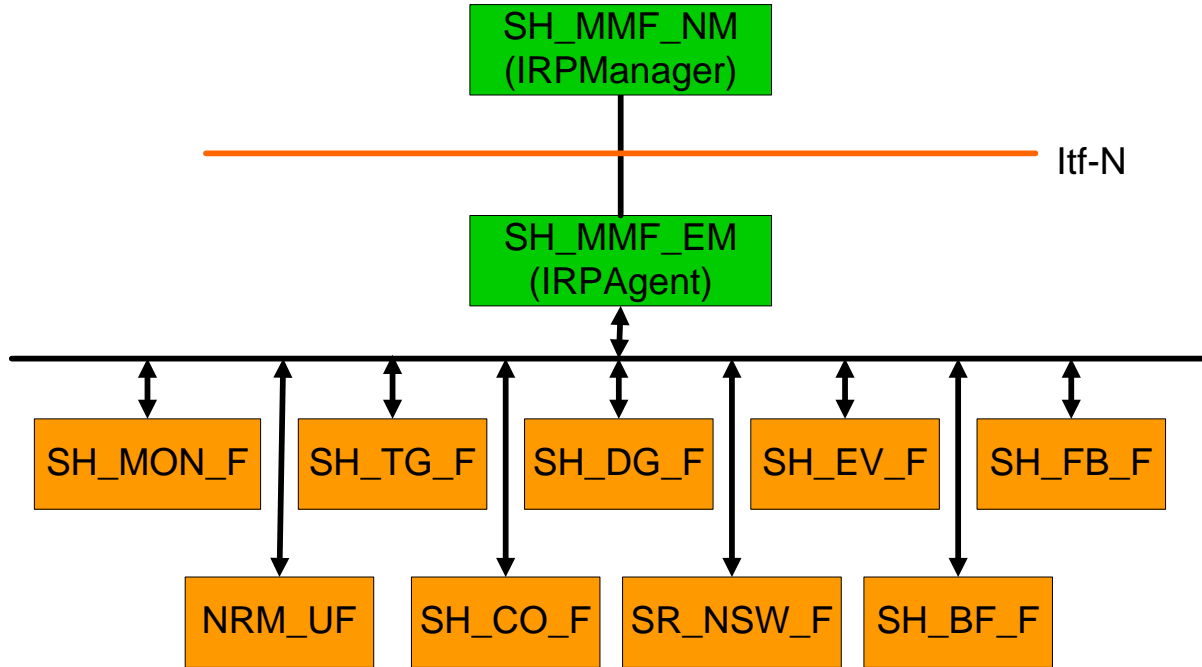

Figure 7.2-1: Self-healing Reference Model

Annex A (informative): Change history

Change history							
Date	TSG #	TSG Doc.	CR	Rev	Subject/Comment	Old	New
Sep 2009	SP-45	SP-090551	-	-	Presentation to SA for information	---	1.0.0
Mar 2011	SP-51	SP-110120	--	--	Presentation to SA for Approval	1.0.0	2.0.0
Mar 2011	--	--	--	--	Publication	2.0.0	10.0.0
2012-09	-	-	-	-	Update to Rel-11 version (MCC)	10.0.0	11.0.0