

3GPP TS 32.453 V11.0.0 (2011-09)

Technical Specification

**3rd Generation Partnership Project;
Technical Specification Group Services and System Aspects;
Telecommunication management;
Performance Management (PM);
Performance measurements
Home enhanced Node B (HeNB) Subsystem (HeNS)
(Release 11)**



The present document has been developed within the 3rd Generation Partnership Project (3GPP™) and may be further elaborated for the purposes of 3GPP. The present document has not been subject to any approval process by the 3GPP Organizational Partners and shall not be implemented. This Specification is provided for future development work within 3GPP only. The Organizational Partners accept no liability for any use of this Specification. Specifications and reports for implementation of the 3GPP™ system should be obtained via the 3GPP Organizational Partners' Publications Offices.

Keywords

OAM, HeNB, PM

3GPP

Postal address

3GPP support office address

650 Route des Lucioles - Sophia Antipolis
Valbonne - FRANCE
Tel.: +33 4 92 94 42 00 Fax: +33 4 93 65 47 16

Internet

<http://www.3gpp.org>

Copyright Notification

No part may be reproduced except as authorized by written permission.
The copyright and the foregoing restriction extend to reproduction in all media.

© 2011, 3GPP Organizational Partners (ARIB, ATIS, CCSA, ETSI, TTA, TTC).
All rights reserved.

UMTS™ is a Trade Mark of ETSI registered for the benefit of its members
3GPP™ is a Trade Mark of ETSI registered for the benefit of its Members and of the 3GPP Organizational Partners
GSM® and the GSM logo are registered and owned by the GSM Association

Contents

Foreword	5
Introduction	5
1 Scope	7
2 References.....	7
3 Measurement family and abbreviations	9
3.1 Measurement family	9
3.2 Abbreviations.....	9
4 Functionality related measurements.....	10
4.1 Measurements related to HeNB-GW	10
4.1.1 Signalling Plane related measurements	10
4.1.1.1 Numbers of incoming SCTP packets on the S1 interface, from HeNB to HeNB GW	10
4.1.1.2 Numbers of outgoing SCTP packets on the S1 interface, from HeNB GW to HeNB	10
4.1.1.3 Numbers of octets of incoming SCTP packets on the S1 interface, from HeNB to HeNB GW	10
4.1.1.4 Numbers of octets of outgoing SCTP packets on the S1 interface, from HeNB GW to HeNB.....	11
4.1.2 User plane related measurements	11
4.1.2.1 Numbers of incoming GTP-U packets of S1 interface, from HeNB to HeNB GW	11
4.1.2.2 Numbers of outgoing GTP-U packets of S1 interface, from HeNB GW to HeNB.....	11
4.1.2.3 Numbers of octets of incoming GTP-U packets of S1 interface, from HeNB to HeNB GW	12
4.1.2.4 Numbers of octets of outgoing GTP-U packets of S1 interface, from HeNB GW to HeNB	12
4.2 Measurements related to HeNB	12
4.2.1 Measurements related to CSG service	12
4.2.1.1 Overview	12
4.2.1.2 Mean number of attached CSG UEs in HeNB	13
4.2.1.3 Inbound CSG mobility measurements	14
4.2.1.3.1 Attempted inbound mobility for UEs to CSG cells or Hybrid cells in RRC_CONNECTED mode.....	14
4.2.1.3.2 Successful inbound mobility for UEs to CSG cells or Hybrid cells in RRC_CONNECTED mode.....	14
4.2.1.3.3 Failed inbound mobility for UEs to CSG cells or Hybrid cells in RRC_CONNECTED mode.....	14
4.2.2 Measurements related to RRC	15
4.2.2.1 Overview	15
4.2.2.2 RRC connection establishments	15
4.2.2.2.1 Attempted RRC connection establishments	15
4.2.2.2.2 Successful RRC connection establishments.....	16
4.2.2.2.3 Failed RRC connection establishments.....	16
4.2.3 Measurements related to E-RAB	17
4.2.3.1 Overview	17
4.2.3.2 Initial E-RAB setup.....	18
4.2.3.2.1 Number of initial E-RABs attempted to setup.....	18
4.2.3.2.2 Number of initial E-RABs successfully established.....	19
4.2.3.2.3 Number of initial E-RABs failed to setup	19
4.2.3.3 E-RAB setup.....	19
4.2.3.3.1 Number of E-RABs attempted to setup	20
4.2.3.3.2 Number of E-RABs successfully established	20
4.2.3.3.3 Number of E-RABs failed to setup.....	20
4.2.3.4 E-RAB release request by HeNS	21
4.2.3.4.1 Number of E-RABs requested to release initiated by HeNB per QCI.....	21
4.2.3.4.2 Number of E-RABs requested to release initiated by HeNB per cause	21
4.2.3.5 E-RAB for Direct User Plane Path between HeNB and LGW	21
4.2.3.5.1 Number of Direct User Plane Path.....	21
4.2.3.5.1 Number of Direct User Plane Path attempted to setup.....	22
4.2.3.5.2 Number of Direct User Plane Path successfully established.....	22
4.2.3.5.3 Number of Direct User Plane Path failed to setup	22
4.2.4 Measurements related to handover.....	23

4.2.4.1	Overview	23
4.2.4.2	eNB related Handovers	24
4.2.4.2.1	Attempted outgoing handover to eNB per handover cause.....	24
4.2.4.2.2	Successful outgoing handover to eNB per handover cause.....	25
4.2.4.2.3	Failed outgoing handover to eNB per handover cause.....	25
4.2.4.2.4	Attempted incoming handover from eNB per handover cause.....	26
4.2.4.2.5	Successful incoming handover from eNB per handover cause.....	26
4.2.4.2.6	Failed incoming handover from eNB per handover cause.....	26
4.2.4.3	Inter-RAT Handovers.....	27
4.2.4.3.1	Attempted outgoing handovers to UTRAN per handover cause.....	27
4.2.4.3.2	Successful outgoing handovers to UTRAN per handover cause.....	27
4.2.4.3.3	Failed outgoing handovers to UTRAN per handover cause.....	27
4.2.4.3.4	Attempted outgoing handovers to GERAN per handover cause.....	28
4.2.4.3.5	Successful outgoing handovers to GERAN per handover cause.....	28
4.2.4.3.6	Failed outgoing handovers to GERAN per handover cause.....	28
4.2.5	Measurements related to PDCP SDU bit-rate	29
4.2.5.1	Average DL cell PDCP SDU bit-rate.....	29
4.2.5.2	Average UL cell PDCP SDU bit-rate.....	29
4.2.5.3	Maximum DL cell PDCP SDU bit-rate	30
4.2.5.4	Maximum UL cell PDCP SDU bit-rate	30
4.2.6	Measurements related to Packet Delay and Drop Rate.....	30
4.2.6.1	Average DL PDCP SDU delay.....	30
4.2.6.2	DL PDCP SDU drop rate	31
4.2.7	Measurements related to Packet Loss Rate.....	31
4.2.7.1	DL PDCP SDU air interface loss rate.....	31
4.2.7.2	UL PDCP SDU loss rate.....	31
Annex A:	Use cases for performance measurements definition.....	33
A.1	Use case of the SCTP signalling measurements.....	33
A.2	Use case of HeNB-GW user plane measurements.....	33
A.3	CSG service related performance	33
A.4	RRC related performance	33
A.5	E-RAB related performance.....	34
A.6	Handover related performance	34
A.7	Radio bearer QoS related performance	34
A.8	Packet delay, drop rate and loss rate related performance.....	34
Annex B:	Change history.....	36

Foreword

This Technical Report has been produced by the 3rd Generation Partnership Project (3GPP).

The contents of the present document are subject to continuing work within the TSG and may change following formal TSG approval. Should the TSG modify the contents of the present document, it will be re-released by the TSG with an identifying change of release date and an increase in version number as follows:

Version x.y.z

where:

- x the first digit:
 - 1 presented to TSG for information;
 - 2 presented to TSG for approval;
 - 3 or greater indicates TSG approved document under change control.
- y the second digit is incremented for all changes of substance, i.e. technical enhancements, corrections, updates, etc.
- z the third digit is incremented when editorial only changes have been incorporated in the document.

Introduction

The present document is part of a TS-family covering the 3rd Generation Partnership Project; Technical Specification Group Services and System Aspects; Telecommunication management; as identified below:

32.401	Performance Management (PM); Concept and requirements
52.402	Performance Management (PM); Performance measurements – GSM
32.404	Performance Management (PM); Performance measurements - Definitions and template
32.405	Performance Management (PM); Performance measurements Universal Terrestrial Radio Access Network (UTRAN)
32.406	Performance Management (PM); Performance measurements Core Network (CN) Packet Switched (PS) domain
32.407	Performance Management (PM); Performance measurements Core Network (CN) Circuit Switched (CS) domain
32.408	Performance Management (PM); Performance measurements Teleservice
32.409	Performance Management (PM); Performance measurements IP Multimedia Subsystem (IMS)
32.452	Performance Management (PM); Performance measurements Home Node B Subsystem (HNS)
32.453	Performance Management (PM); Performance measurements Home enhanced Node B Subsystem (HeNS)

The present document is part of a set of specifications, which describe the requirements and information model necessary for the standardised Operation, Administration and Maintenance (OA&M) of a multi-vendor Home enhanced Node B Subsystem (HeNS).

During the lifetime of HeNS, its logical and physical configuration will undergo changes of varying degrees and frequencies in order to optimise the utilisation of the network resources. These changes will be executed through network configuration management activities and/or network engineering, see 3GPP TS 32.600 [1].

Many of the activities involved in the daily operation and future network planning of HeNS require data on which to base decisions. This data refers to the load carried by the network and the grade of service offered. In order to produce this data performance measurements are executed in the NEs, which comprise the network. The data can then be transferred to an external system, e.g. an Operations System (OS) in TMN terminology, for further evaluation. The purpose of the present document is to describe the mechanisms involved in the collection of the data and the definition of the data itself.

Annex B of TS 32.404[2] helps in the definition of new performance measurements that can be submitted to 3GPP for potential adoption and inclusion in the present document. Annex B of TS 32.404[2] discusses a top-down performance measurement definition methodology that focuses on how the end-user of performance measurements can use the measurements.

1 Scope

The present document describes the measurements for Home enhanced Node B Subsystem (HeNS).

HeNS [3] consists of a HeNB and optionally a HeNB GW. And, it is connected by means of the standard S1 interface to the EPC (Evolved Packet Core), more specifically to the MME (Mobility Management Entity) by means of the S1-MME interface and to the Serving Gateway (S-GW) by means of the S1-U interface

TS 32.401 [4] describes Performance Management concepts and requirements.

The present document is valid for all measurement types provided by an implementation of HeNS.

Only measurement types that are specific to HeNS are defined within the present documents. Vendor specific measurement types used in HeNS are not covered. Instead, these could be applied according to manufacturer's documentation.

Measurements related to "external" technologies (such as ATM or IP) as described by "external" standards bodies (e.g. ITU-T or IETF) shall only be referenced within this specification, wherever there is a need identified for the existence of such a reference.

The definition of the standard measurements is intended to result in comparability of measurement data produced in a multi-vendor network, for those measurement types that can be standardised across all vendors' implementations.

The structure of the present document is as follows:

- Header 1: Network Element (e.g. measurements related to HeNB and HeNB GW);
- Header 2: Measurement function (e.g. HeNB registration measurements);
- Header 3: Measurements.

2 References

The following documents contain provisions which, through reference in this text, constitute provisions of the present document.

- References are either specific (identified by date of publication, edition number, version number, etc.) or non-specific.
- For a specific reference, subsequent revisions do not apply.
- For a non-specific reference, the latest version applies. In the case of a reference to a 3GPP document (including a GSM document), a non-specific reference implicitly refers to the latest version of that document *in the same Release as the present document*.

- [1] 3GPP TS 32.600: "Telecommunication management; Configuration Management (CM); Concept and high-level requirements".
- [2] 3GPP TS 32.404: "Performance Management (PM); Performance measurements - Definitions and template".
- [3] 3GPP TS 23.401: "General Packet Radio Service (GPRS) enhancements for Evolved Universal Terrestrial Radio Access Network (E-UTRAN) access".
- [4] 3GPP TS 32.401: "Telecommunication management; Performance Management (PM); Concept and requirements".
- [5] 3GPP TS 36.300: "Evolved Universal Terrestrial Radio Access (E-UTRA); and Evolved Universal Terrestrial Radio Access Network (E-UTRAN); Overall description; Stage 2 (Release 9)".
- [6] 3GPP TS 36.413: "Technical Specification Group Radio Access Network; Evolved Universal Terrestrial Radio Access Network (E-UTRAN); S1 Application Protocol (S1AP)".
- [7] 3GPP TS 36.331: "Evolved Universal Terrestrial Radio Access (E-UTRA); Radio Resource Control (RRC) protocol specification".

- [8] 3GPP TS 36.314: "Evolved Universal Terrestrial Radio Access (E-UTRA); Layer 2–Measurements".

3 Measurement family and abbreviations

3.1 Measurement family

The measurement names defined in the present document are all beginning with a prefix containing the measurement family name (e.g. S1.IncSctpPkt). This family name identifies all measurements which relate to a given functionality and it may be used for measurement administration (see 3GPP TS 32.401 [4]).

The list of families currently used in the present document is as follows:

- S1 (measurements related to S1 interface).
- CSG (measurements related to CSG membership)
- HO (measurements related to handover)
- DRB (measurements related to Data Radio Bearer)

3.2 Abbreviations

For the purposes of the present document, the following abbreviations apply:

3G	3 rd Generation
3GPP	3G Partnership Project
CS	Circuit switched
CN	Core Network
NE	Network Element
NM	Network Manager
OA&M	Operation, Administration and Maintenance
OS	Operations System (EM, NM)
PM	Performance Management
QoS	Quality of Service
UMTS	Universal Mobile Telecommunications System

You can find below a list of abbreviations used within the measurement types for field E of the measurement template (see 3GPP TS 32.404 [2]).

Ans	Answer(ed)
Att	Attempted
Auth	Authorization
Cs	Circuit switched
DER	Discrete Event Registration
DeReg	De-Registration
Dmn	Domain
Estab	Establish(ment)
Fail	Failed(/Failure)
Fwd	Forward(ed)
Inc	Incoming
Ind	Indication
Nbr	Number
Rel	Release(s,d)
Res	Resource
Succ	Success(es,ful)

4 Functionality related measurements

The measurements defined in this clause are related to the functionality aspect performance. The detailed measurements for each function are defined in the following subclauses.

4.1 Measurements related to HeNB-GW

A HeNB GW is optional in a HeNB subsystem. If the HeNB is connected by means of the standard S1 interface to the HeNB GW, more specifically through HeNB GW to the MME (Mobility Management Entity) by means of the S1-MME interface and to the Serving Gateway (S-GW) by means of the S1-U interface.

NOTE 1: These measurements are only effective when HeNB GW is included in HeNS.

4.1.1 Signalling Plane related measurements

4.1.1.1 Numbers of incoming SCTP packets on the S1 interface, from HeNB to HeNB GW

a) This measurement provides the number of SCTP data packets sent from HeNB to HeNB GW which have been accepted and processed by the SCTP protocol entity on the S1 interface.

b) CC.

c) Receipt of a SCTP data PDU from HeNB to HeNB GW on the S1-MME interface.

d) A single integer value.

e) S1.IncSctpPkt

f) HeNBGW Function

g) Valid for packet switching

h) EPS

4.1.1.2 Numbers of outgoing SCTP packets on the S1 interface, from HeNB GW to HeNB

a) This measurement provides the number of SCTP data packets sent from HeNB GW to HeNB which have been generated by the SCTP protocol entity on the S1 interface.

b) CC.

c) Transmission of a SCTP data PDU from HeNB GW to HeNB on the S1-MME interface.

d) A single integer value.

e) S1.OutSctpPkt

f) HeNBGW Function

g) Valid for packet switching

h) EPS

4.1.1.3 Numbers of octets of incoming SCTP packets on the S1 interface, from HeNB to HeNB GW

a) This measurement provides the number of octets of SCTP data packets sent from HeNB to HeNB GW which have been accepted and processed by the SCTP protocol entity on the S1 interface.

- b) CC.
- c) Receipt of a SCTP data PDU from HeNB to HeNB GW on the S1 interface.
- d) A single integer value.
- e) S1.IncSctpOct
- f) HeNBGWFunction
- g) Valid for packet switching
- h) EPS

4.1.1.4 Numbers of octets of outgoing SCTP packets on the S1 interface, from HeNB GW to HeNB

- a) This measurement provides the number of octets of SCTP data packets sent from HeNB GW to HeNB which have been generated by the SCTP protocol entity on the S1 interface.
- b) CC.
- c) Transmission of a SCTP data PDU from HeNB GW to HeNB on the Iuh interface.
- d) A single integer value.
- e) S1.OutSctpOct
- f) HeNBGWFunction
- g) Valid for packet switching
- h) EPS

4.1.2 User plane related measurements

4.1.2.1 Numbers of incoming GTP-U packets of S1 interface, from HeNB to HeNB GW

- a) This measurement provides the number of GTP-U data packets on the user plane, sent from HeNB to HeNB GW on S1 interface.
- b) CC.
- c) Receipt of an GTP-U data PDU from HeNB to HeNB GW on the user plane of S1 interface.
- d) A single integer value.
- e) S1.IncPsPkt
- f) HeNBGWFunction
- g) Valid for packet switched traffic
- h) EPS

4.1.2.2 Numbers of outgoing GTP-U packets of S1 interface, from HeNB GW to HeNB

- a) This measurement provides the number of GTP-U data packets sent on the user plane, from HeNB GW to HeNB on S1 interface.
- b) CC.

- c) Transmission of an GTP-U data PDU from HeNB GW to HeNB on the user plane of S1 interface.
- d) A single integer value.
- e) S1.OutPsPkt
- f) HeNBGWFunction
- g) Valid for packet switched traffic
- h) EPS

4.1.2.3 Numbers of octets of incoming GTP-U packets of S1 interface, from HeNB to HeNB GW

- a) This measurement provides the number of octets of GTP-U data packets on the user plane, sent from HeNB to HeNB GW on S1 interface.
- b) CC.
- c) Receipt of an GTP-U data PDU from HeNB to HeNB GW on the user plane of S1 interface.
- d) A single integer value.
- e) S1.IncPsOct
- f) HeNBGWFunction
- g) Valid for packet switched traffic
- h) EPS

4.1.2.4 Numbers of octets of outgoing GTP-U packets of S1 interface, from HeNB GW to HeNB

- a) This measurement provides the number of octets of GTP-U data packets on the user plane, sent from HeNB GW to HeNB on S1 interface.
- b) CC.
- c) Transmission of an GTP-U data PDU from HeNB GW to HeNB on the user plane of S1 interface.
- d) A single integer value.
- e) S1.OutPsOct
- f) HeNBGWFunction
- g) Valid for packet switched traffic
- h) EPS

4.2 Measurements related to HeNB

4.2.1 Measurements related to CSG service

4.2.1.1 Overview

A Closed Subscriber Group identifies subscribers of an operator who are permitted to access one or more cells of the PLMN but which have restricted access (CSG cells).

The CSG inbound mobility procedure provides means for UEs switching from other cells to CSG HeNBs or to Hybrid Cells in RRC_CONNECTED mode. The procedure is triggered when the target HeNB receives a HANDOVER

REQUEST message from the MME, including the CSG id and – for handover to a hybrid cell – CSG Membership Status. In case the target HeNB is connected to MME through HeNB GW, the HANOVER REQUEST message should be sent from the HeNB GW. The successful CSG inbound mobility rate poses an important impact on the QoE, therefore it is essential to define related measurements

The CSG inbound mobility procedure is initiated by MME.

Performance measurement definitions in this subclause are based on 3GPP TS 36.413 [6].

The following paragraphs are of interest for this purpose:

- HANOVER REQUEST
- HANOVER REQUEST ACKNOWLEDGE
- HANOVER FAILURE

These paragraphs show in particular the following diagram.

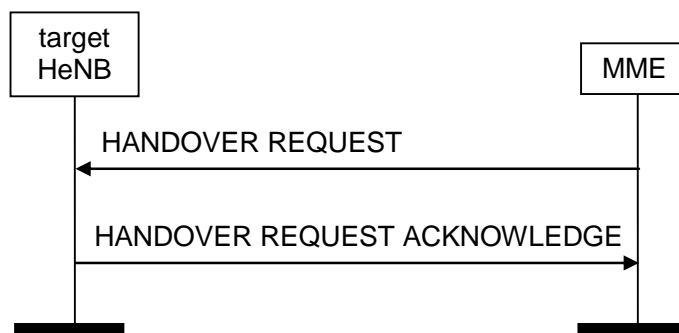

Figure 1 CSG UE Inbound Procedure: Successful Operation

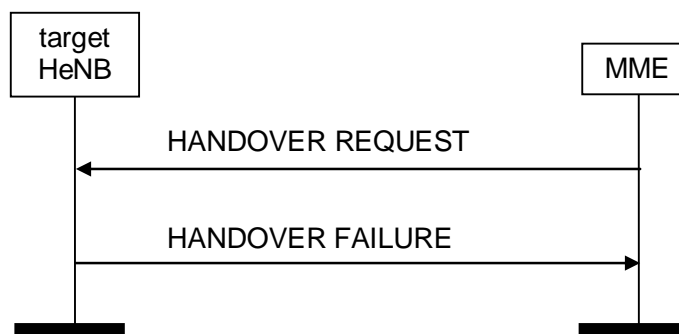

Figure 2 CSG UE Inbound Procedure: Unsuccessful Operation

4.2.1.2 Mean number of attached CSG UEs in HeNB

- a) This measurement provides the mean number of attached CSG UEs in the HeNB.
- b) SI
- c) This measurement is obtained by sampling at a pre-defined interval the number of CSG UEs in the HeNB and then taking the arithmetic mean (see TS 36.300 [5]).
- d) A single integer value
- e) CSG.MeanNbrUsr
- f) HeNB
- g) Valid for circuit and packet switched traffic
- h) EPS

4.2.1.3 Inbound CSG mobility measurements

The three measurement types defined in the subclause 4.2.1.3 are subject to the "2 out of 3 approach".

4.2.1.3.1 Attempted inbound mobility for UEs to CSG cells or Hybrid cells in RRC_CONNECTED mode

- a) This measurement provides the number of attempted inbound mobility for UEs to CSG cells or hybrid cells in RRC_CONNECTED mode
- b) CC
- c) Receipt by the HeNB of a S1AP message HANDOVER REQUEST from the MME/HeNB GW with the "CSG id" IE, and "CSG Membership Status" IE for handover to a hybrid cell (see TS 36.413 [6]).
- d) A single integer value.
- e) CSG.AttInboundMobility
- f) HeNB
- g) Valid for circuit and packet switched traffic
- h) EPS

4.2.1.3.2 Successful inbound mobility for UEs to CSG cells or Hybrid cells in RRC_CONNECTED mode

- a) This measurement provides the number of successful inbound mobility for UEs to CSG cells or hybrid cells in RRC_CONNECTED mode
- b) CC
- c) Transmission by the HeNB of a S1AP message HANDOVER REQUEST ACKNOWLEDGE to the MME/HeNB GW, corresponding to the receipt by the HeNB of a S1AP message HANDOVER REQUEST from the MME/HeNB GW with the "CSG id" IE, and "CSG Membership Status" IE for handover to a hybrid cell (see TS 36.413 [6]).
- d) A single integer value.
- e) CSG.SuccInboundMobility
- f) HeNB
- g) Valid for circuit and packet switched traffic
- h) EPS

4.2.1.3.3 Failed inbound mobility for UEs to CSG cells or Hybrid cells in RRC_CONNECTED mode

- a) This measurement provides the number of failed successful inbound mobility for UEs to CSG cells or hybrid cells in RRC_CONNECTED mode
- b) CC
- c) Transmission by the HeNB of a S1AP message HANDOVER FAILURE to the MME/HeNB GW, corresponding to the receipt by the HeNB of a S1AP message HANDOVER REQUEST from the MME/HeNB GW with the "CSG id" IE, and "CSG Membership Status" IE for handover to a hybrid cell (see TS 36.413 [6]).
- d) Each measurement is an integer value. The number of measurements is equal to the number of causes supported plus a possible sum value identified by the *.sum* suffix.
- e) CSG.FailedInboundMobility. *Cause*

where *Cause* identifies the failure cause.

- f) HeNB
- g) Valid for circuit and packet switched traffic
- h) EPS

4.2.2 Measurements related to RRC

4.2.2.1 Overview

Performance Measurement definitions in this subclause are based on 3GPP TS 36.413 [6].

The following paragraphs are of interest for this purpose:

- RRC CONNECTION REQUEST
- RRC CONNECTION SETUP COMPLETE
- RRC CONNECTION REJECT

These paragraphs show in particular the following diagrams.

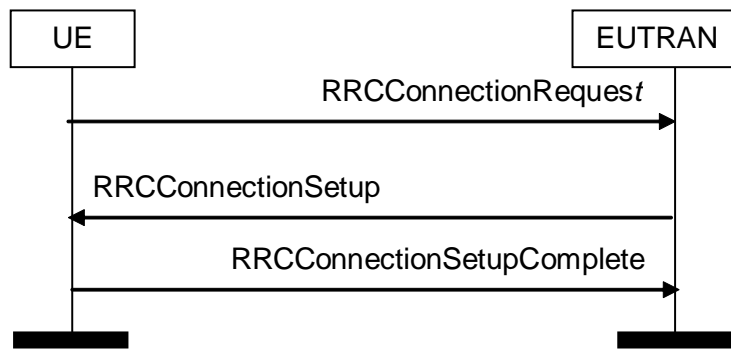

Figure 3 RRC connection establishment, successful

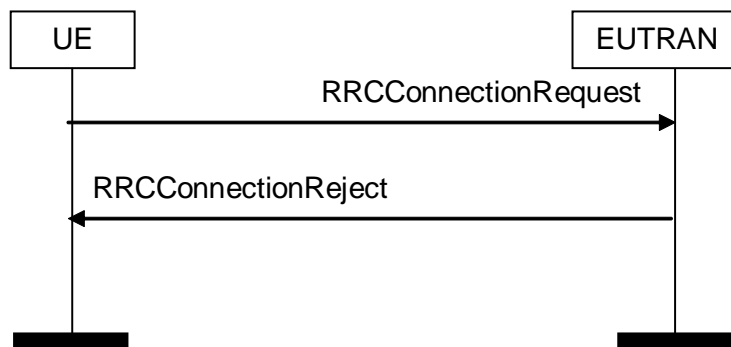

Figure 4 RRC connection establishment, network reject

4.2.2.2 RRC connection establishments

The three measurement types defined in the clause 4.2.2.2 for HeNB are subject to the "2 out of 3 approach".

4.2.2.2.1 Attempted RRC connection establishments

- a) This measurement provides the number of RRC connection establishment attempts for each establishment cause.
- b) CC

- c) Receipt of an RRC CONNECTION REQUEST message by the HeNB from the UE. Each RRC Connection Request message received is added to the relevant per cause measurement. The possible causes are included in TS 36.331 [7]. The sum of all supported per cause measurements shall equal the total number of RRC Connection Establishment attempts. In case only a subset of per cause measurements is supported, a sum subcounter will be provided first.
- d) Each measurement is an integer value. The number of measurements is equal to the number of causes plus a possible sum value identified by the *.sum* suffix.
- e) The measurement name has the form RRC.AttConnEstab.*Cause* where *Cause* identifies the Establishment Cause.
- f) HeNB
- g) Valid for packet switched traffic
- h) EPS

4.2.2.2.2 Successful RRC connection establishments

- a) This measurement provides the number of successful RRC establishments for each establishment cause.
- b) CC
- c) Receipt by the HeNB of a RRC CONNECTION SETUP COMPLETE message following a RRC establishment attempt. Each RRC Connection Setup Complete message received is added to the relevant per cause measurement. The possible causes are included in TS 36.331 [7]. The sum of all supported per cause measurements shall equal the total number of RRC Connection Establishments. In case only a subset of per cause measurements is supported, a sum subcounter will be provided first.
- d) Each measurement is an integer value. The number of measurements is equal to the number of causes plus a possible sum value identified by the *.sum* suffix.
- e) The measurement name has the form RRC.SuccConnEstab.*Cause* where *Cause* identifies the Establishment Cause.
- f) HeNB
- g) Valid for packet switched traffic
- h) EPS

4.2.2.2.3 Failed RRC connection establishments

- a) This measurement provides the number of RRC establishment failures for each rejection cause.
- b) CC
- c) Transmission of an RRC CONNECTION REJECT message by the HeNB to the UE or an expected RRC Connection Setup Complete message not received by the HeNB. Each failed RRC connection establishment is added to the relevant per establishment cause measurement. The possible causes are included in TS 36.331 [7]. The sum of all supported per cause measurements shall equal the total number of RRC connection establishment failures. In case only a subset of per cause measurements is supported, a sum subcounter will be provided first.
- d) Each measurement is an integer value. The number of measurements is equal to the number of causes plus a possible sum value identified by the *.sum* suffix.
- e) The measurement name has the form RRC.FailConnEstab.*Cause* where *Cause* identifies the Rejection Cause.
- f) HeNB
- g) Valid for packet switched traffic
- h) EPS

4.2.3 Measurements related to E-RAB

4.2.3.1 Overview

Performance Measurement definitions in this subclause are based on 3GPP TS 36.413 [6].

The following paragraphs are of interest for this purpose:

- INITIAL CONTEXT SETUP REQUEST
- INITIAL CONTEXT SETUP RESPONSE
- INITIAL CONTEXT SETUP FAILURE
- UE CONTEXT RELEASE REQUEST
- E-RAB SETUP REQUEST;
- E-RAB SETUP RESPONSE;
- E-RAB RELEASE INDICATION.

These paragraphs show in particular the following diagrams.

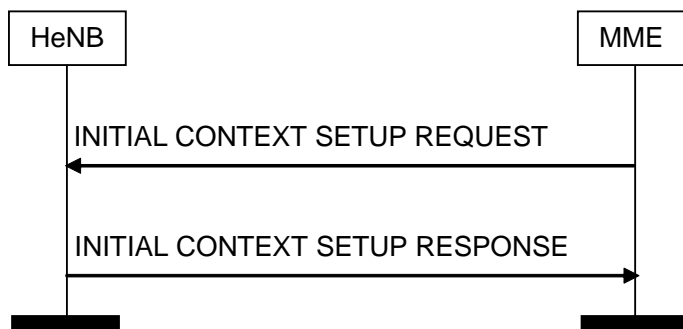

Figure 5 Initial Context Setup procedure. Successful operation

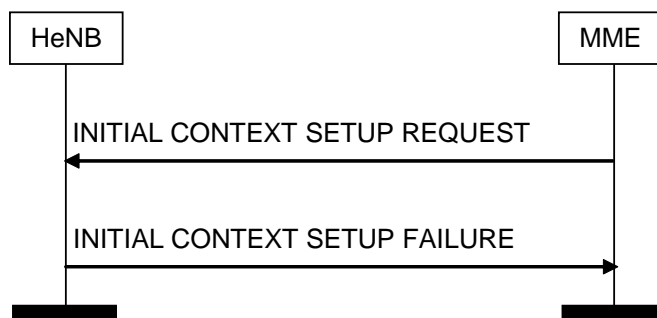

Figure 6 Initial Context Setup procedure. Unsuccessful operation



Figure 7 UE Context Release Request procedure. Successful operation

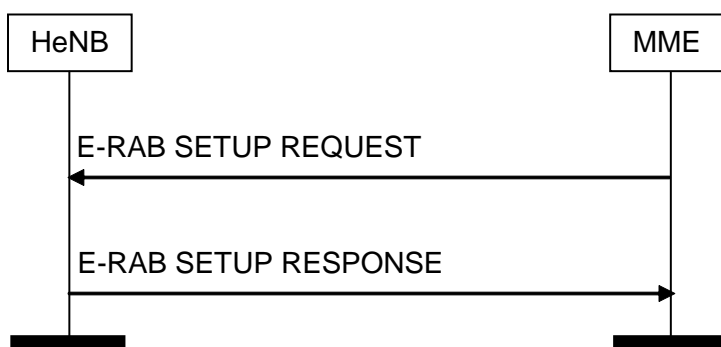

Figure 8 E-RAB Setup procedure s



Figure 9 E-RAB Release INDICATION procedure. Successful operation

4.2.3.2 Initial E-RAB setup

The three measurement types defined in the clause 4.2.3.2 for HeNB are subject to the "2 out of 3 approach".

4.2.3.2.1 Number of initial E-RABs attempted to setup

- a) This measurement provides the number of initial E-RABs attempted to setup. The measurement is split into subcounters per E-RAB QoS level (QCI).
- b) CC
- c) On receipt by the HeNB of an INITIAL CONTEXT SETUP REQUEST message, each requested E-RABs in the message is added to the relevant measurement per QCI, the possible QCIs are included in TS 36.413 [6]. The sum of all supported per QCI measurements shall equal the total number of SAE Bearers attempted to setup. In case only a subset of per QCI measurements is supported, a sum subcounter will be provided first.
- d) Each measurement is an integer value. The number of measurements is equal to the number of QCIs plus a possible sum value identified by the *.sum* suffix.

- e) The measurement name has the form ERAB.EstabInitAttNbr.*QCI* where *QCI* identifies the E-RAB level quality of service class.
- f) HeNB
- g) Valid for packet switched traffic
- h) EPS

4.2.3.2.2 Number of initial E-RABs successfully established

- a) This measurement provides the number of initial E-RABs successfully established. The measurement is split into subcounters per E-RAB QoS level (*QCI*).
- b) CC
- c) On transmission by the HeNB of an INITIAL CONTEXT SETUP RESPONSE message, each E-RAB successfully established is added to the relevant measurement per *QCI*, the possible *QCIs* are included in TS 36.413 [6]. The sum of all supported per *QCI* measurements shall equal the total number of E-RABs successfully setup. In case only a subset of per *QCI* measurements is supported, a sum subcounter will be provided first.
- d) Each measurement is an integer value. The number of measurements is equal to the number of *QCIs* plus a possible sum value identified by the *.sum* suffix.
- e) The measurement name has the form ERAB.EstabInitSuccNbr.*QCI* where *QCI* identifies the E-RAB level quality of service class.
- f) HeNB
- g) Valid for packet switched traffic
- h) EPS

4.2.3.2.3 Number of initial E-RABs failed to setup

- a) This measurement provides the number of initial E-RABs failed to setup. The measurement is split into subcounters per failure cause.
- b) CC
- c) On transmission by the HeNB of an INITIAL CONTEXT SETUP RESPONSE, or INITIAL CONTEXT SETUP FAILURE message, each E-RAB failed to establish is added to the relevant measurement per cause, the possible causes are included in TS 36.413 [6]. The sum of all supported per cause measurements shall equal the total number of E-RABs failed to setup. In case only a subset of per cause measurements is supported, a sum subcounter will be provided first.
- d) Each measurement is an integer value. The number of measurements is equal to the number of causes plus a possible sum value identified by the *.sum* suffix.
- e) The measurement name has the form ERAB.EstabInitFailNbr.*Cause* where *Cause* identifies the cause resulting in the initial E-RAB setup failure.
- f) HeNB
- g) Valid for packet switched traffic
- h) EPS

4.2.3.3 E-RAB setup

The three measurement types defined in the clause 4.2.3.3 for HeNB are subject to the "2 out of 3 approach".

4.2.3.3.1 Number of E-RABs attempted to setup

- a) This measurement provides the number of E-RABs attempted to setup. The measurement is split into subcounters per E-RAB QoS level (QCI).
- b) CC
- c) On receipt by the HeNB of a E-RAB SETUP REQUEST message, each requested E-RAB in the message is added to the relevant measurement per QCI, the possible QCIs are included in TS 36.413 [6]. The sum of all supported per QCI measurements shall equal the total number of additional E-RABs attempted to setup. In case only a subset of per QCI measurements is supported, a sum subcounter will be provided first.
- d) Each measurement is an integer value. The number of measurements is equal to the number of QCIs plus a possible sum value identified by the *.sum* suffix.
- e) The measurement name has the form ERAB.EstabAttNbr.*QCI* where *QCI* identifies the E-RAB level quality of service class.
- f) HeNB
- g) Valid for packet switched traffic
- h) EPS

4.2.3.3.2 Number of E-RABs successfully established

- a) This measurement provides the number of E-RABs successfully established. The measurement is split into subcounters per E-RAB QoS level (QCI).
- b) CC
- c) On transmission by the HeNB of a E-RAB SETUP RESPONSE message, each E-RAB successfully established is added to the relevant measurement per QCI, the possible QCIs are included in TS 36.413 [6]. The sum of all supported per QCI measurements shall equal the total number of E-RABs successfully setup. In case only a subset of per QCI measurements is supported, a sum subcounter will be provided first.
- d) Each measurement is an integer value. The number of measurements is equal to the number of QCIs plus a possible sum value identified by the *.sum* suffix.
- e) The measurement name has the form ERAB.EstabSuccNbr.*QCI* where *QCI* identifies the E-RAB level quality of service class.
- f) HeNB
- g) Valid for packet switched traffic
- h) EPS

4.2.3.3.3 Number of E-RABs failed to setup

- a) This measurement provides the number of E-RABs failed to setup. The measurement is split into subcounters per failure cause.
- b) CC
- c) On transmission by the HeNB of a E-RAB SETUP RESPONSE message, each E-RAB failed to establish is added to the relevant measurement per cause, the possible causes are included in TS 36.413 [6]. The sum of all supported per cause measurements shall equal the total number of E-RABs failed to setup. In case only a subset of per cause measurements is supported, a sum subcounter will be provided first.
- d) Each measurement is an integer value. The number of measurements is equal to the number of causes plus a possible sum value identified by the *.sum* suffix.
- e) The measurement name has the form ERAB.EstabFailNbr.*Cause* where *Cause* identifies the cause resulting in the additional E-RAB setup failure.

- f) HeNB
- g) Valid for packet switched traffic
- h) EPS

4.2.3.4 E-RAB release request by HeNB

4.2.3.4.1 Number of E-RABs requested to release initiated by HeNB per QCI

- a) This measurement provides the number of E-RABs requested to release initiated by HeNB. The measurement is split into subcounters per E-RAB QoS level (QCI).
- b) CC
- c) On transmission by the HeNB of a E-RAB RELEASE INDICATION or UE CONTEXT RELEASE REQUEST message, each corresponding E-RAB requested to release is added to the relevant measurement per QCI, the possible QCIs are included in TS 36.413 [6]. The sum of all supported per QCI measurements shall equal the total number of E-RABs requested to release initiated by HeNB. In case only a subset of per QCI measurements is supported, a sum subcounter will be provided first.
- d) Each measurement is an integer value. The number of measurements is equal to the number of QCIs plus a possible sum value identified by the *.sum* suffix.
- e) The measurement name has the form ERAB.RelEnbNbr.*QCI* where *QCI* identifies the E-RAB level quality of service class.
- f) HeNB
- g) Valid for packet switched traffic
- h) EPS

4.2.3.4.2 Number of E-RABs requested to release initiated by HeNB per cause

- a) This measurement provides the number of E-RABs requested to release initiated by HeNB. The measurement is split into subcounters per cause.
- b) CC
- c) On transmission by the HeNB of a E-RAB RELEASE INDICATION or UE CONTEXT RELEASE REQUEST message, each corresponding E-RAB requested to release is added to the relevant measurement per cause. Possible causes are included in TS 36.413 [6].
- d) Each measurement is an integer value. The number of measurements is equal to the number of supported causes.
- e) The measurement names have the form ERA B.RelEnbNbr.*cause* where *cause* identifies the reason for the E-RABs release request initiated by HeNB.
- f) HeNB
- g) Valid for packet switched traffic
- h) EPS

4.2.3.5 E-RAB for Direct User Plane Path between HeNB and LGW

4.2.3.5.1 Number of Direct User Plane Path

The three measurement types defined in the clauses 4.2.3.5.2, 4.2.3.5.3 and 4.2.3.5.4 are subject to the "2 out of 3 approach".

4.2.3.5.1 Number of Direct User Plane Path attempted to setup

- a) This measurement provides the number of direct user plane path between HeNB and Local GW attempted to setup.
- b) CC
- c) On receipt by the HeNB of an INITIAL CONTEXT SETUP REQUEST message (for initial E-RAB setup) or E-RAB SETUP REQUEST message (for other E-RAB setup) and the PDN connection is established for Local IP Access, each requested E-RABs in the message is added to the relevant measurement. The message includes a Correlation ID for enabling the direct user plane path between the HeNB and the L-GW. The Correlation ID is equal to the user plane PDN GW TEID (GTP-based S5) or GRE key (PMIP-based S5). (3GPP TS 23.401[3]).
- d) Integer.
- e) The measurement name has the form ERAB.EstabDirectPathLGWAttNbr.
- f) HeNB
- g) Valid for packet switched traffic
- h) EPS

4.2.3.5.2 Number of Direct User Plane Path successfully established

- a) This measurement provides the number of direct user plane path between HeNB and Local GW successfully established.
- b) CC
- c) On transmission by the HeNB of an INITIAL CONTEXT SETUP RESPONSE message (for initial E-RAB setup) or E-RAB SETUP RESPONSE message (for other E-RAB setup) and the PDN connection is established for Local IP Access, each E-RAB successfully established is added to the relevant measurement.
- d) Integer.
- e) The measurement name has the form ERAB.EstabDirectPathLGWSuccNbr.
- f) HeNB
- g) Valid for packet switched traffic
- h) EPS

4.2.3.5.3 Number of Direct User Plane Path failed to setup

- a) This measurement provides the number of direct user plane path between HeNB and Local GW E-RABs failed to setup.
- b) CC
- c) On transmission by the HeNB of an INITIAL CONTEXT SETUP RESPONSE/INITIAL CONTEXT SETUP FAILURE message (for initial E-RAB setup) or E-RAB SETUP RESPONSE message (for other E-RAB setup) and the PDN connection is established for Local IP Access, each E-RAB failed to establish is added to the relevant measurement per cause, the possible causes are included in TS 36.413[6]. The sum of all supported per cause measurements shall equal the total number of E-RABs failed to setup. In case only a subset of per cause measurements is supported, a sum subcounter will be provided first.
- d) Each measurement is an integer value. The number of measurements is equal to the number of causes plus a possible sum value identified by the *.sum* suffix.
- e) The measurement name has the form ERAB.EstabDirectPathLGWFailNbr.*Cause*, where *Cause* identifies the cause resulting in the E-RAB setup failure.
- f) HeNB
- g) Valid for packet switched traffic
- h) EPS

4.2.4 Measurements related to handover

4.2.4.1 Overview

Performance Measurement definitions in this subclause are based on 3GPP TS 36.413 [6].

The following paragraph is of interest for this purpose:

- HANDOVER REQUEST
- HANDOVER REQUEST ACKNOWLEDGE
- RRC CONNECTION RECONFIGURATION
- RRC CONNECTION RECONFIGURATION COMPLETE
- RRC CONNECTION REESTABLISHMENT
- MOBILITY FROM EUTRA COMMAND
- UE CONTEXT RELEASE COMMAND

These paragraphs show in particular the following diagrams:

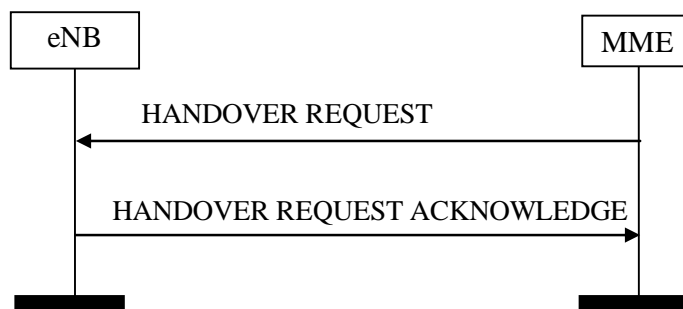

Figure10: Handover resource allocation: successful

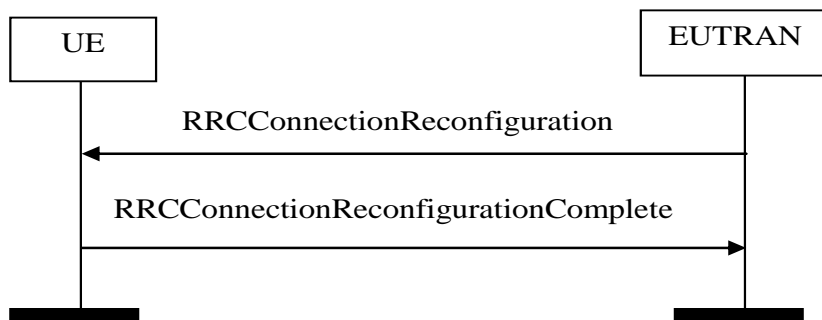

Figure11: RRC connection reconfiguration, successful

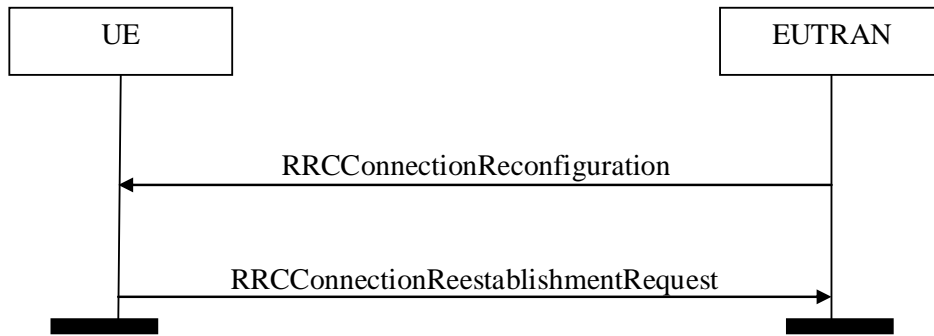

Figure12: RRC connection reconfiguration, failure



Figure13: Mobility from E-UTRA, successful

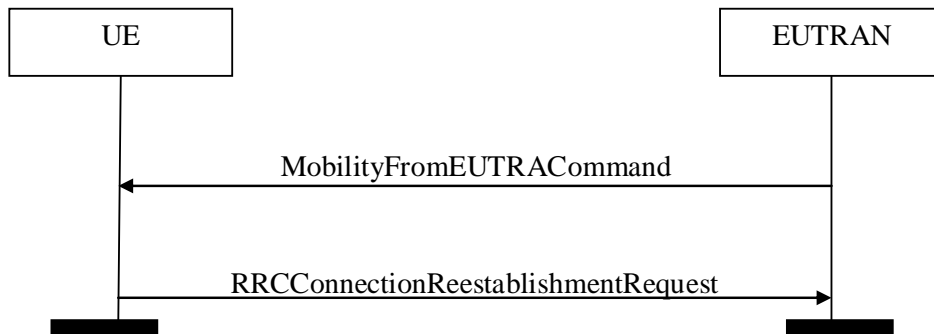

Figure14: Mobility from E-UTRA, failure

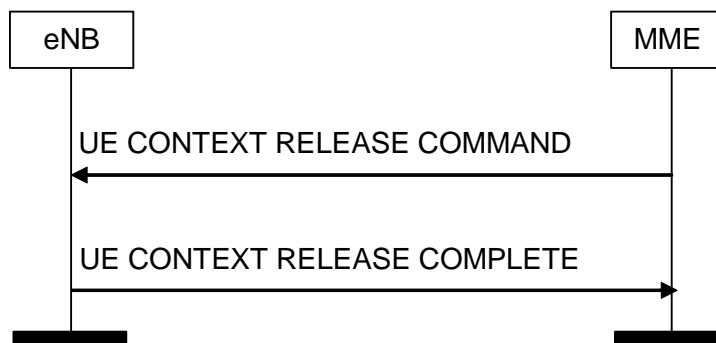

Figure15: UE Context Release procedure. Successful

4.2.4.2 eNB related Handovers

4.2.4.2.1 Attempted outgoing handover to eNB per handover cause

- a) This measurement provides the number of attempted outbound handover to eNB per handover cause.

- b) CC.
- c) Transmission of the *RRCConnectionReconfiguration* message from HeNB to the UE, indicating the handover to eNB (see TS 36.331 [7]). The sum of all supported per cause measurements shall equal the total number of handover to eNB events. In case only a subset of per cause measurements is supported, a sum subcounter will be provided first.
- d) Each measurement is an integer value. The number of measurements is equal to the number of causes supported plus a possible sum value identified by the .sum suffix.
- e) HO. *ToeNBAtt.Cause*
where *Cause* identifies the cause for handover.
- f) HeNB
- g) Valid for packet switched traffic
- h) EPS

4.2.4.2.2 Successful outgoing handover to eNB per handover cause

- a) This measurement provides the number of successful outbound handover to eNB per handover cause.
- b) CC.
- c) Receipt of a S1AP message *UE CONTEXT RELEASE COMMAND* sent from the MME to the HeNB, indicating a successful handover to eNB with specific cause (see TS 36.413 [6]). The sum of all supported per cause measurements shall equal the total number of outgoing intra-eNB handover events. In case only a subset of per cause measurements is supported, a sum subcounter will be provided first.
- d) Each measurement is an integer value. The number of measurements is equal to the number of causes supported plus a possible sum value identified by the .sum suffix
- e) HO. *ToeNBSucc.Cause*
where *Cause* identifies the cause for handover.
- f) HeNB
- g) Valid for packet switched traffic
- h) EPS

4.2.4.2.3 Failed outgoing handover to eNB per handover cause

- a) This measurement provides the number of failed outbound handover to eNB per handover cause.
- b) CC
- c) Transmission of the *RRCConnectionReestablishmentRequest* message by the UE to the HeNB, indicating the RRC connection reestablishment (see TS 36.331 [7]). The sum of all supported per cause measurements shall equal the total number of handover from eNB events. In case only a subset of per cause measurements is supported, a sum subcounter will be provided first.
- d) Each measurement is an integer value. The number of measurements is equal to the number of causes supported plus a possible sum value identified by the .sum suffix
- e) HO. *ToeNBFail.Cause*
where *Cause* identifies the cause for handover.
- f) HeNB
- g) Valid for packet switched traffic
- h) EPS

4.2.4.2.4 Attempted incoming handover from eNB per handover cause

- a) This measurement provides the number of attempted inbound handover from eNB per handover cause.
- b) CC.
- c) Receipt of a S1AP message *HANDOVER REQUEST* sent from the MME to the HeNB (see TS 36.413 [6]). The sum of all supported per cause measurements shall equal the total number of handover from eNB events. In case only a subset of per cause measurements is supported, a sum subcounter will be provided first.
- d) Each measurement is an integer value. The number of measurements is equal to the number of causes supported plus a possible sum value identified by the .sum suffix.
- e) HO.FromeNBAtt.Cause
where *Cause* identifies the cause for handover.
- f) HeNB
- g) Valid for packet switched traffic
- h) EPS

4.2.4.2.5 Successful incoming handover from eNB per handover cause

- a) This measurement provides the number of successful inbound handover from eNB per handover cause.
- b) CC.
- c) Receipt of a *RRCConnectionReconfigurationComplete* message sent from the UE to the HeNB, indicating a successful handover from eNB with specific cause (see TS 36.331 [7]). The sum of all supported per cause measurements shall equal the total number of handover from eNB events. In case only a subset of per cause measurements is supported, a sum subcounter will be provided first.
- d) Each measurement is an integer value. The number of measurements is equal to the number of causes supported plus a possible sum value identified by the .sum suffix
- e) HO.FromeNBSucc.Cause
where *Cause* identifies the cause for handover.
- f) HeNB
- g) Valid for packet switched traffic
- h) EPS

4.2.4.2.6 Failed incoming handover from eNB per handover cause

- a) This measurement provides the number of failed inbound handover from eNB per handover cause.
- b) CC
- c) Transmission of the *RRCConnectionReestablishmentRequest* message by the UE to the eNB, indicating the RRC connection reestablishment (see TS 36.331 [7]). The sum of all supported per cause measurements shall equal the total number of handover from eNB events. In case only a subset of per cause measurements is supported, a sum subcounter will be provided first.
- d) Each measurement is an integer value. The number of measurements is equal to the number of causes supported plus a possible sum value identified by the .sum suffix
- e) HO.FromeNBFail.Cause
where *Cause* identifies the cause for handover.
- f) HeNB
- g) Valid for packet switched traffic

h) EPS

4.2.4.3 Inter-RAT Handovers

4.2.4.3.1 Attempted outgoing handovers to UTRAN per handover cause

- a) This measurement provides the number of attempted outgoing handovers to UTRAN per cause and target cell specific.
- b) CC.
- c) Transmission of the *MobilityFromEUTRACCommand* message from the HeNB to the UE indicating the attempt of an outgoing handover from HeNS to UTRAN with a specific cause (see TS 36.331 [7]). The sum of all supported per cause measurements shall equal the total number of outgoing handover to UTRAN events. In case only a subset of per cause measurements is supported, a sum subcounter will be provided first.
- d) Each measurement is an integer value. The number of measurements is equal to the number of causes supported plus a possible sum value identified by the *.sum* suffix.
- e) *HO.ToUtranAtt.Cause*
where *Cause* identifies the cause for handover
- f) HeNB
- g) Valid for packet switched traffic
- h) EPS

4.2.4.3.2 Successful outgoing handovers to UTRAN per handover cause

- a) This measurement provides the number of successful outgoing handovers to UTRAN per cause target cell specific.
- b) CC.
- c) Receipt of a S1AP message UE CONTEXT RELEASE COMMAND sent from the MME to the HeNB, indicating a successful handover initiated due to a specific cause (see TS 36.413 [6]). The sum of all supported per cause measurements shall equal the total number of outgoing handover to UTRAN events. In case only a subset of per cause measurements is supported, a sum subcounter will be provided first.
- d) Each measurement is an integer value. The number of measurements is equal to the number of causes supported plus a possible sum value identified by the *.sum* suffix.
- e) *HO.ToUtranSucc.Cause*
where *Cause* indicating the cause for handover.
- f) HeNB
- g) Valid for packet switched traffic
- h) EPS

4.2.4.3.3 Failed outgoing handovers to UTRAN per handover cause

- a) This measurement provides the number of failed outgoing handovers to UTRAN per cause target cell specific.
- b) CC
- c) Transmission of the *RRCConnectionReestablishmentRequest* message by the UE to the HeNB, indicating the RRC connection reestablishment(see TS 36.331 [7]). The sum of all supported per cause measurements shall equal the total number of outgoing handover to UTRAN events. In case only a subset of per cause measurements is supported, a sum subcounter will be provided first.

- d) Each measurement is an integer value. The number of measurements is equal to the number of causes supported plus a possible sum value identified by the *.sum* suffix.
- e) *HO.ToUtranFail.Cause*
where *Cause* indicating the cause for handover.
- f) HeNB
- g) Valid for packet switched traffic
- h) EPS

4.2.4.3.4 Attempted outgoing handovers to GERAN per handover cause

- a) This measurement provides the number of attempted outgoing handovers to GERAN per cause and target cell specific.
- b) CC.
- c) Transmission of the *MobilityFromEUTRACCommand* message from the HeNB to the UE indicating the attempt of an outgoing handover from HeNB to GERAN with a specific cause (see TS 36.331 [7]). The sum of all supported per cause measurements shall equal the total number of outgoing handover to GERAN events. In case only a subset of per cause measurements is supported, a sum subcounter will be provided first.
- d) Each measurement is an integer value. The number of measurements is equal to the number of causes supported plus a possible sum value identified by the *.sum* suffix.
- e) *HO.ToGeranAtt.Cause*
where *Cause* identifies the cause for handover
- f) HeNB
- g) Valid for packet switched traffic
- h) EPS

4.2.4.3.5 Successful outgoing handovers to GERAN per handover cause

- a) This measurement provides the number of successful outgoing handovers to GERAN per cause target cell specific.
- b) CC.
- c) Receipt of a S1AP message UE CONTEXT RELEASE COMMAND sent from the MME to the HeNB, indicating a successful handover initiated due to a specific cause (see TS 36.413 [6]). The sum of all supported per cause measurements shall equal the total number of outgoing handover to GERAN events. In case only a subset of per cause measurements is supported, a sum subcounter will be provided first.
- d) Each measurement is an integer value. The number of measurements is equal to the number of causes supported plus a possible sum value identified by the *.sum* suffix.
- e) *HO.ToGeranSucc.Cause*
where *Cause* indicating the cause for handover.
- f) HeNB
- g) Valid for packet switched traffic
- h) EPS

4.2.4.3.6 Failed outgoing handovers to GERAN per handover cause

- a) This measurement provides the number of failed outgoing handovers to GERAN per cause target cell specific.
- b) CC.

- c) Transmission of the *RRCConnectionReestablishmentRequest* message by the UE to the HeNB, indicating the RRC connection reestablishment(see TS 36.331 [7]). The sum of all supported per cause measurements shall equal the total number of outgoing handover to UTRAN events. In case only a subset of per cause measurements is supported, a sum subcounter will be provided first.
- d) Each measurement is an integer value. The number of measurements is equal to the number of causes supported plus a possible sum value identified by the *.sum* suffix.
- e) *HO.ToGeranFail.Cause*
where *Cause* indicating the cause for handover.
- f) HeNB
- g) Valid for packet switched traffic
- h) EPS

4.2.5 Measurements related to PDCP SDU bit-rate

4.2.5.1 Average DL cell PDCP SDU bit-rate

- a) This measurement provides the average cell bit-rate of PDCP SDUs on the downlink. This represents the ingress rate of user plane traffic to the HeNB (via S1). The measurement is split into subcounters per SAE Bearer QoS level (QCI).
- b) CC
- c) This measurement is obtained according to the Scheduled IP Throughput definition in 3GPP TS 36.314 [8].
- d) Each measurement is an integer value representing the bit-rate measured in kb/s. The number of measurements is equal to the number of QCIs plus a possible sum value identified by the *.sum* suffix.
- e) The measurement name has the form *DRB.PdcpSduBitrateDL.QCI*
where *QCI* identifies the SAE Bearer level quality of service class.
- f) HeNB
- g) Valid for packet switched traffic
- h) EPS

4.2.5.2 Average UL cell PDCP SDU bit-rate

- a) This measurement provides the average cell bit-rate of PDCP SDUs on the uplink. This represents successful transmissions of user plane traffic; control signalling and retransmissions are excluded from this measure. The measurement is split into subcounters per SAE Bearer QoS level (QCI).
- b) CC
- c) This measurement is obtained according to the Scheduled IP Throughput definition in 3GPP TS 36.314 [8].
- d) Each measurement is an integer value representing the bit-rate measured in kb/s. The number of measurements is equal to the number of QCIs plus a possible sum value identified by the *.sum* suffix.
- e) The measurement name has the form *DRB.PdcpSduBitrateUL.QCI*
where *QCI* identifies the SAE Bearer level quality of service class.
- f) HeNB
- g) Valid for packet switched traffic
- h) EPS

4.2.5.3 Maximum DL cell PDCP SDU bit-rate

- a) This measurement provides the maximum cell bit-rate of PDCP SDUs on the downlink. This represents the maximum ingress rate of user plane traffic to the HeNB (via S1). This is a sum counter measured across all QCIs.
- b) SI
- c) This measurement is obtained according to the Scheduled IP Throughput definition in 3GPP TS 36.314 [8].
- d) A single integer value representing the maximum bit-rate measured in kb/s.
- e) DRB.PdcpSduBitrateDlMax
- f) HeNB
- g) Valid for packet switched traffic
- h) EPS

4.2.5.4 Maximum UL cell PDCP SDU bit-rate

- a) This measurement provides the maximum cell bit-rate of PDCP SDUs measured on the uplink. This represents successful transmissions of user plane traffic; control signalling and retransmissions are excluded from this measure. This is a sum counter measured across all QCIs.
- b) SI
- c) This measurement is obtained according to the scheduled IP throughput definition in 3GPP TS 36.314 [8].
- d) A single integer value representing the maximum bit-rate measured in kb/s.
- e) DRB.PdcpSduBitrateUlMax
- f) HeNB
- g) Valid for packet switched traffic
- h) EPS

4.2.6 Measurements related to Packet Delay and Drop Rate

4.2.6.1 Average DL PDCP SDU delay

- a) This measurement provides the average (arithmetic mean) PDCP SDU delay on the downlink. The measurement is split into subcounters per ERAB Bearer QoS level (QCI).
- b) DER (n=1)
- c) This measurement is obtained according to the definition in 3GPP TS 36.314 [8].
- d) Each measurement is an integer value representing the mean delay in ms. The number of measurements is equal to the number of QCIs plus a possible sum value identified by the *.sum* suffix.
- e) The measurement name has the form DRB.PdcpSduDelayDl.QCI where *QCI* identifies the ERAB Bearer level quality of service class.
- f) HeNB
- g) Valid for packet switched traffic
- h) EPS

4.2.6.2 DL PDCP SDU drop rate

- a) This measurement provides the fraction of IP packets (PDCP SDUs) which are dropped on the downlink. Only user-plane traffic (DTCH) is considered. A dropped packet is one whose context is removed from the HeNB without any part of it having been transmitted on the air interface. Packets discarded during handover are excluded from the count. The measurement is split into subcounters per ERAB Bearer QoS level (QCI).
- b) SI
- c) This measurement is obtained according to the definition in 3GPP TS 36.314 [8]. Separate counters are maintained for each QCI. In case only a subset of per QCI measurements is supported, a drop rate subcounter calculated across all QCIs will be provided first.
- d) Each measurement is an integer value representing the drop rate multiplied by 1E6. The number of measurements is equal to the number of QCIs plus a possible sum value identified by the *.sum* suffix.
- e) The measurement name has the form DRB.PdcpSduDropRateDl.QCI where *QCI* identifies the target ERAB Bearer level quality of service class.
- f) HeNB
- g) Valid for packet switched traffic
- h) EPS

4.2.7 Measurements related to Packet Loss Rate

4.2.7.1 DL PDCP SDU air interface loss rate

- a) This measurement provides the fraction of IP packets (PDCP SDUs) which are lost (not successfully transmitted) on the downlink air interface. Only user-plane traffic (DTCH) is considered. A lost packet is one whose context is removed from the HeNB after an attempt has been made to transmit part or all of the packet on the air interface but the whole packet has not been successfully transmitted. The measurement is split into subcounters per ERAB Bearer QoS level (QCI).
- b) SI
- c) This measurement is obtained according to the definition in 3GPP TS 36.314 [8]. Separate counters are maintained for each QCI. In case only a subset of per QCI measurements is supported, a loss rate subcounter calculated across all QCIs will be provided first.
- d) Each measurement is an integer value representing the air interface loss rate multiplied by 1E6. The number of measurements is equal to the number of QCIs plus a possible sum value identified by the *.sum* suffix.
- e) The measurement name has the form DRB.PdcpSduAirLossRateDl.QCI where *QCI* identifies the target ERAB Bearer level quality of service class.
- f) HeNB
- g) Valid for packet switched traffic
- h) EPS

4.2.7.2 UL PDCP SDU loss rate

- a) This measurement provides the fraction of IP packets (PDCP SDUs) which are lost (not successfully received) on the uplink. Only user-plane traffic (DTCH) and only PDCP SDUs that have entered PDCP (and given a PDCP sequence number) are considered. The measurement is split into subcounters per ERAB Bearer QoS level (QCI).
- b) SI

- c) This measurement is obtained according to the definition in 3GPP TS 36.314 [8]. Separate counters are maintained for each QCI. In case only a subset of per QCI measurements is supported, a loss rate subcounter calculated across all QCIs will be provided first.
- d) Each measurement is an integer value representing the loss rate multiplied by 1E6. The number of measurements is equal to the number of QCIs plus a possible sum value identified by the *.sum* suffix.
- e) The measurement name has the form DRB.PdcpSduLossRateUl.*QCI* where *QCI* identifies the target ERAB Bearer level quality of service class.
- f) HeNB
- g) Valid for packet switched traffic
- h) EPS

Annex A: Use cases for performance measurements definition

A.1 Use case of the SCTP signalling measurements

In order to avoid the overload of HeNB-GW, SCTP signaling measurements data will be combined with HeNB-GW user plane measurement data to reflect load status on HeNB-GW. When HeNB GW is present in HeNS, it is fairly a straightforward way to collect such performance data from HeNB GW. Especially, operators deploy a dedicated HeNS management system.

In addition, the ratio of signaling to data bandwidth usage is very useful to monitor some abnormal events, such as if the ratio of them is too high, some unusual events are possible happened. Therefore, the operator could analyze whether some problems exist in the network or not, and may find out root-causes led to the bad conditions, finally resolve the problems.

A.2 Use case of HeNB-GW user plane measurements

HeNB-GW user plane related measurements are used to measure data volume on S1 interface including incoming and outgoing of data packets and octets for GTP-U. When HeNB GW is present in HeNS, it is fairly a straightforward way to collect such performance data from HeNB GW. Especially, operators deploy a dedicated HeNS management system.

Based on that, the measurements are useful to analyze data volumes and velocity from HeNB-GW point-of-view. If the data volume is too high, more interface bandwidth should be deployed, or HeNB-GW load balance should be considered. If data velocity is too high, the packet forwarding capacity of HeNB-GW should be enhanced to avoid data congestion.

In addition, HeNB-GW user plane related measurements could be together with other performance measurements to analyze network performance to find out the abnormal events.

A.3 CSG service related performance

A Closed Subscriber Group identifies subscribers of an operator who are permitted to access one or more PLMN cells which have restricted access. It is a new added feature in HeNB to facilitate the provisioning of new service. The collection of CSG related performance on HeNB level could clearly reflect the status of delivered service for each subscriber. In addition to this, HeNB is an exclusive signalling terminator on the HeNS side when HeNB GW is absent. Therefore, it is necessary to capture the CSG performance data on HeNB level.

By calculating these parameters relating to CSG service, the operator can obtain the mean number of CSG UEs and the successful rate of inbound mobility for UEs. The mean number of CSG UEs indicates how many users accessing the CSG service, which is a key performance for service utilization. The successful rate of inbound mobility for UEs performs a key indicator of CSG service accessibility. As low handover success rate will impact user experience, it is important to define measurements to capture handover success rate. Furthermore, detailed analysis of handover failures is essential to know what causes the handovers.

Based on these indicators, the operator can optimize the service coverage and enhance the user experience.

A.4 RRC related performance

RRC relevant performance parameters are essential to evaluate the radio link quality. Especially, a HeNB is a kind of CPE. Depending on HeNB trial experience, there might be serious interference happened between HeNB cell and Macro Cell. The collection of RRC performance on each HeNB could directly indicate radio link quality. The collection of RRC performance is also helpful for operator to locate the root causes if there is service faults are occurred.

Based on that, these measurements are useful for drawing connection rate and drop rate of HeNB system. Both rates reflect connectivity and continuity for system services, and also direct key performance indicators of user experience. By analysing these indicators, the operator can keep track of the network as well as enhance user experience.

A.5 E-RAB related performance

E-RAB management procedure includes E-RAB Setup procedure and E-RAB Release Request procedure. The purpose of the E-RAB Setup procedure is to assign resources on Uu and S1 for one or several E-RABs and to setup corresponding Data Radio Bearers for a given UE. Based on the E-RAB level QoS parameters IE the HeNB shall establish a Data Radio Bearer and allocate the required resources on Uu. If E-RABs are failed to be established, the involved services may fail. Therefore, the collection on per E-RAB QCI will give operators important indications whether a particular service type is running well or not. Especially, operators deliver some new feature services to customers.

During daily maintenance of network, measurements regarding E-RAB establishment and release are useful for operators to evaluate E-RAB management procedures, to analyze failure reasons of E-RAB establishment and to analyze the causes of E-RAB release. In addition, the E-RAB performance data on per QCI could give operators possibilities to assess the quality of specific service.

Based on that, these measurements are useful for drawing connection rate and drop rate of HeNB system. Both rates reflect connectivity and continuity for system services, and also direct key performance indicators of user experience. By analysing these indicators, the operator can keep track of the network as well as enhance user experience.

A.6 Handover related performance

In telecommunications, the term handover refers to the process of transferring an ongoing call or data session from one channel connected to the core network to another, which can be categorized according to RATs.

During daily maintenance of network, it is essential in network operations to follow the success rate of various handover. Low handover success rate will impact user experience, therefore it is important to define measurements to follow handover success rate.

By calculating these parameters, we can obtain the success rate of handovers for UEs, both eNBs and inter-RAT related. All these parameters are direct key indicators of service connectivity and also useful for operators to evaluate handover procedures and analyze failure reasons. To go for further analysis of handover failures, it is also essential to know what causes the handovers. By analysing these indicators, the operator can inspect the network as well as enhance user experience.

A.7 Radio bearer QoS related performance

A fundamental measure of QoS is the throughput (data rate) of the cell. The total cell throughput measured across all radio bearers gives an indication of the loading and activity in the cell. Adding a per QCI counter allows the loading on the different QCIs to be measured. For example, if QCI 1 is used exclusively for VoIP then the loading of conversational speech can be directly determined. The maximum throughput can indicate to the operator whether there is enough capacity in the network. Separate counters should be configured on the downlink and uplink. The PDCP SDU bit-rate helps to evaluate the usage of bandwidth and radio resource. Operators could perform network optimization based on the throughput statistics. Hence it is important to monitor the total cell throughput.

A.8 Packet delay, drop rate and loss rate related performance

Latency is of prime concern for some services, particularly conversational services like speech and instant messaging. A counter is added to measure the mean delay for IP packets incurred within the HeNB. Separate counters are provided per QCI which are particularly useful when the QCI is used by very few services and the packet sizes vary little. It is only practical to measure packet delays on the downlink.

When a cell is heavily loaded congestion can take place. When congestion is not severe the impact is typically the incurrence of additional delay for non-GBR radio bearers. However, when congestion is severe the HeNB may be forced to discard packets. It is important for the operator to have visibility of packet discard so that corrective action can be instigated (for example, by adjusting admission control settings in the network). It is only practical to measure packet discards on the downlink. Packet discards on handover should not be included in the count.

The downlink air interface packet loss can be directly compared with the PELR value of a QCI to see if the packet loss (over the air interface) aspect of quality of service is being met within the cell. On the downlink this measurement can be added to the congestion losses (see DL packet drop rate) to determine the total packet loss rate at the HeNB. Consequently, the downlink useful bit-rate can be estimated by scaling the measurement of the downlink PDCP ingress bit-rate by $(1 - \text{DL packet drop rate}) (1 - \text{air interface packet loss rate})$.

The uplink air interface packet loss rate (per QCI) can be compared directly with the PELR defined for that QCI. An estimate of the uplink air interface packet loss may be provided by the "Uplink PDCP SDU loss rate". This uplink measurement is based on PDCP sequence numbers and cannot precisely measure the air interface losses. Any packets discarded by the UE within the protocol stack (i.e. at layer 2) are also counted since they will have been given a PDCP sequence number. Discards at layer 3 are not counted.

Annex B: Change history

Change history							
Date	TSG #	TSG Doc.	CR	Rev	Subject/Comment	Old	New
2011-03	SP-51	SP-110115	--	--	Presentation to SA for Information and Approval	---	1.0.0
2011-03	--	--	--	--	Publication	1.0.0	10.0.0
2011-09	SP-53	SP-110634	001	2	Addition of measurements related to Direct User Plane Path between HeNB and LGW	10.0.0	11.0.0