

# 3GPP TS 32.407 V11.2.0 (2012-03)

---

*Technical Specification*

**3rd Generation Partnership Project;  
Technical Specification Group Services and System Aspects;  
Telecommunication management;  
Performance Management (PM);  
Performance measurements;  
Core Network (CN) Circuit Switched (CS) domain;  
UMTS and combined UMTS/GSM  
(Release 11)**

---



The present document has been developed within the 3<sup>rd</sup> Generation Partnership Project (3GPP<sup>TM</sup>) and may be further elaborated for the purposes of 3GPP. The present document has not been subject to any approval process by the 3GPP Organizational Partners and shall not be implemented. This Specification is provided for future development work within 3GPP only. The Organizational Partners accept no liability for any use of this Specification. Specifications and reports for implementation of the 3GPP<sup>TM</sup> system should be obtained via the 3GPP Organizational Partners' Publications Offices.

---

Keywords

---

GSM, UMTS, management, performance

**3GPP**

Postal address

---

3GPP support office address

---

650 Route des Lucioles - Sophia Antipolis  
Valbonne - FRANCE  
Tel.: +33 4 92 94 42 00 Fax: +33 4 93 65 47 16

Internet

---

<http://www.3gpp.org>

---

**Copyright Notification**

No part may be reproduced except as authorized by written permission.  
The copyright and the foregoing restriction extend to reproduction in all media.

© 2012, 3GPP Organizational Partners (ARIB, ATIS, CCSA, ETSI, TTA, TTC).  
All rights reserved.

UMTS™ is a Trade Mark of ETSI registered for the benefit of its members  
3GPP™ is a Trade Mark of ETSI registered for the benefit of its Members and of the 3GPP Organizational Partners  
LTE™ is a Trade Mark of ETSI currently being registered for the benefit of its Members and of the 3GPP Organizational Partners  
GSM® and the GSM logo are registered and owned by the GSM Association

# Contents

Foreword .....	8
1 Scope .....	10
2 References.....	10
3 Measurement family and abbreviations .....	12
3.1 Measurements .....	12
3.2 Abbreviations .....	12
4 Measurements related to the MSC Server.....	14
4.1 Call control management .....	14
4.1.1 Overview .....	14
4.1.1.1 Basic traffic model.....	14
4.1.1.2 Basic signalling flow .....	15
4.1.2 MO/MT call related performance.....	16
4.1.2.1 MSC-S acknowledged originating calls .....	17
4.1.2.2 MSC-S acknowledged terminating calls .....	18
4.1.2.3 Attempted mobile originating calls .....	18
4.1.2.4 Successful mobile originating call .....	18
4.1.2.5 Answered mobile originating calls .....	19
4.1.2.6 Attempted mobile terminating calls .....	19
4.1.2.7 Successful mobile terminating calls .....	20
4.1.2.8 Answered mobile terminating calls .....	20
4.1.2.9 Failed mobile calls caused by subscribers in originating MSC-S for Inter-MSC call .....	21
4.1.2.10 Failed mobile calls caused by subscribers in terminating MSC-S for Inter-MSC call .....	22
4.1.2.11 Failed mobile calls caused by subscribers in MSC-S for Intra-MSC call.....	23
4.1.3 MSC-S (BICC) call related performance .....	24
4.1.3.1 Attempted incoming calls .....	24
4.1.3.2 Successful incoming calls .....	25
4.1.3.3 Answered incoming calls .....	25
4.1.3.4 Attempted outgoing calls .....	25
4.1.3.5 Successful outgoing calls .....	26
4.1.3.6 Answered outgoing calls .....	26
4.1.4 Trunk group (TDM) call related performance .....	27
4.1.4.1 Seized outgoing calls per trunk group .....	27
4.1.4.2 Successful outgoing calls per trunk group.....	27
4.1.4.3 Answered outgoing calls per trunk group.....	27
4.1.4.4 Number of trunk group overflow .....	28
4.1.4.5 Seized incoming calls per trunk group .....	28
4.1.4.6 Time of all trunks unavailable .....	28
4.1.4.7 Successful incoming calls per trunk group .....	28
4.1.4.8 Answered incoming call per trunk group .....	29
4.1.5 Call establishment quality of service .....	30
4.1.5.1 UE call established time .....	30
4.1.6 Traffic related performance .....	30
4.1.6.1 Successful incoming call traffic .....	30
4.1.6.2 Answered incoming call traffic .....	31
4.1.6.3 Successful mobile originating call traffic .....	31
4.1.6.4 Answered mobile originating call traffic .....	32
4.1.6.5 Successful Mobile terminating call traffic .....	32
4.1.6.6 Answered Mobile terminating call traffic .....	33
4.1.6.7 Successful outgoing traffic .....	33
4.1.6.8 Answered outgoing traffic .....	35
4.1.6.9 Successful transit call traffic .....	35
4.1.6.10 Answered transit call traffic .....	36
4.1.6.11 Seized outgoing call traffic per trunk group.....	36
4.1.6.12 Seized incoming call traffic per trunk group.....	37
4.1.7 Paging related performance .....	38

4.1.7.1	Attempt paging requests per Lac .....	38
4.1.7.2	Successful paging requests per Lac .....	39
4.1.8	Out of band Call codec negotiation related performance .....	40
4.1.8.1	Attempted out of band codec negotiation number .....	40
4.1.8.2	Successful out of band codec negotiation number .....	41
4.1.8.3	Attempted out of band codec modification number .....	41
4.1.8.4	Successful out of band codec modification number .....	41
4.1.8.5	Failed out of band codec modification number .....	42
4.1.9	Measurements based on Observed Destination.....	43
4.1.9.1	Attempted calls for calling party number .....	43
4.1.9.2	Successful calls for calling party number .....	43
4.1.9.3	Answered calls for calling party number .....	44
4.1.9.4	Call Traffic of Observed Destination for calling party number .....	44
4.1.9.5	Attempted calls for called party numbers .....	44
4.1.9.6	Successful calls for the called party numbers .....	45
4.1.9.7	Answered calls for the called party numbers .....	45
4.1.9.8	Call Traffic of Observed Destination for called party number .....	45
4.2	Mobility management .....	46
4.2.1	Overview .....	46
4.2.2	Location update .....	47
4.2.2.1	Attempted intra-VLR location update.....	47
4.2.2.2	Successful intra-VLR location update.....	47
4.2.2.3	Attempted inter-VLR location update.....	48
4.2.2.4	Successful inter-VLR location update.....	48
4.2.2.5	Attempted location update for IMSI attach .....	49
4.2.2.6	Successful location update for IMSI attach.....	49
4.2.2.7	Attempted period location update.....	50
4.2.2.8	Successful period location update.....	50
4.2.3	Hand over inter MSC-S.....	51
4.2.3.1	Attempted subsequent handover back to MSCa .....	51
4.2.3.2	Successful subsequent handover back to MSCa .....	52
4.2.3.3	Attempted subsequent handover to MSCc .....	52
4.2.3.4	Successful subsequent handover to MSCc .....	52
4.2.3.5	Attempted incoming handovers inter MSC-S from UMTS to UMTS .....	53
4.2.3.6	Successful incoming handovers inter MSC-S from UMTS to UMTS .....	53
4.2.3.7	Attempted outgoing handovers inter MSC-S from UMTS to UMTS .....	53
4.2.3.8	Successful outgoing handovers inter MSC-S from UMTS to UMTS .....	54
4.2.3.9	Attempted incoming handovers inter MSC-S from UMTS to GSM .....	54
4.2.3.10	Successful incoming handovers inter MSC-S from UMTS to GSM .....	54
4.2.3.11	Attempted outgoing handovers inter MSC-S from UMTS to GSM .....	55
4.2.3.12	Successful outgoing handovers inter MSC-S from UMTS to GSM .....	55
4.2.4	Handover Intra MSC-S.....	55
4.2.4.1	Attempted Handover Intra MSC-S from UMTS to GSM .....	55
4.2.4.2	Successful Handover Intra MSC-S from UMTS to GSM.....	56
4.2.4.3	Failed Handover Intra MSC-S from UMTS to GSM .....	56
4.2.4.4	Attempted Handover Intra MSC-S from GSM to UMTS.....	56
4.2.4.5	Successful Handover Intra MSC-S from GSM to UMTS.....	56
4.2.4.6	Failed Handover Intra MSC-S from GSM to UMTS .....	57
4.2.4.7	Attempted SRNS Relocation Intra MSC-S from UMTS to UMTS .....	57
4.2.4.8	Successful SRNS Relocation Intra MSC-S from UMTS to UMTS.....	57
4.2.4.9	Failed SRNS Relocation Intra MSC-S from UMTS to UMTS.....	58
4.3	Signalling .....	59
4.3.1	Overview .....	59
4.3.2	M3UA link related measurements.....	59
4.3.2.1	Number of received messages on M3UA link .....	59
4.3.2.2	Number of sent messages on M3UA link.....	59
4.3.2.3	Number of octets received on M3UA link .....	59
4.3.2.4	Number of octets sent on M3UA link .....	60
4.3.2.5	Mean duration of M3UA link congestion.....	60
4.3.2.6	Number of M3UA link congestion times .....	60
4.3.2.7	Mean unavailable time of M3UA link .....	61
4.3.2.8	Number of M3UA link unavailable times .....	61

4.3.3	MTP3 signalling link related measurements .....	61
4.3.3.1	Mean duration of unavailable MTP3 signalling link .....	61
4.3.3.2	Number of MTP3 signalling link unavailable times .....	62
4.3.3.3	Number of MSUs received on MTP3 signalling link .....	62
4.3.3.4	Number of MSUs sent on MTP3 signalling link .....	62
4.3.3.5	Number of octets received on MTP3 signalling link .....	63
4.3.3.6	Number of octets sent on MTP3 signalling link .....	63
4.3.3.7	Number of available MTP3 signalling link .....	63
4.4	Equipment resource .....	64
4.4.1	Overview .....	64
4.4.2	CPU Load .....	64
4.4.2.1	Mean CPU Usage .....	64
4.4.3	Number of subscribers in VLR .....	64
4.4.3.1	Number of registered subscribers in VLR .....	64
4.4.3.2	Number of attached subscribers in VLR .....	65
4.4.3.3	Number of registered national roaming subscribers in VLR .....	65
4.4.3.4	Number of attached national roaming subscribers in VLR .....	65
4.4.3.5	Number of registered international roaming subscriber in VLR .....	66
4.4.3.6	Number of attached international roaming subscribers in VLR .....	66
4.4.4	Octets in MAC layer in MSC-S physical port .....	66
4.4.4.1	Number of octets sent on MAC layer in MSC-S physical port .....	66
4.4.4.2	Number of octets received on MAC layer in MSC-S physical port .....	67
4.4.5	Trunk resource related measurements .....	67
4.4.5.1	Number of available trunks .....	67
4.4.5.2	Number of available circuits in trunk group .....	67
4.4.6	H.248 message related measurements on Mc interface .....	68
4.4.6.1	Number of H.248 messages received on Mc interface .....	68
4.4.6.2	Number of H.248 messages sent on Mc interface .....	68
4.4.6.3	Number of H.248 message octets received on Mc interface .....	68
4.4.6.4	Number of H.248 message octets sent on Mc interface .....	69
4.4.7	BICC message on Nc interface related measurements .....	69
4.4.7.1	Number of BICC messages received on Nc interface .....	69
4.4.7.2	Number of BICC messages sent on Nc interface .....	69
4.4.7.3	Number of octets of BICC message received on Nc interface .....	70
4.4.7.4	Number of octets of BICC message sent on Nc interface .....	70
5	Measurements related to the CS MGW .....	71
5.1	Measurements related to signalling .....	71
5.1.1	Overview .....	71
5.1.2	M3UA link of MGW related performance .....	71
5.1.2.1	Number of messages received on M3UA link .....	71
5.1.2.2	Number of messages sent on M3UA link .....	71
5.1.2.3	Number of octets received on M3UA link .....	72
5.1.2.4	Number of octets sent on M3UA link .....	72
5.1.2.5	Mean duration of M3UA link congestion .....	72
5.1.2.6	Number of M3UA link congestion times .....	73
5.1.2.7	Mean unavailable duration of M3UA link .....	73
5.1.2.8	Number of M3UA link unavailable times .....	73
5.1.3	MTP3/MTP3B signalling link of MGW related performance .....	74
5.1.3.1	Number of MSUs received on MTP3/MTP3B signalling link .....	74
5.1.3.2	Number of MSUs sent on MTP3/MTP3B signalling link .....	74
5.1.3.3	Number of octets received on MTP3/MTP3B signalling link .....	74
5.1.3.4	Number of octets sent on MTP3/MTP3B signalling link .....	75
5.1.3.5	Number of available MTP3/MTP3B signalling link .....	75
5.1.3.6	Number of unavailable times of MTP3/MTP3B signalling link .....	75
5.1.3.7	Mean duration of unavailable MTP3/MTP3B signalling link .....	76
5.1.4	Route set related performance .....	76
5.1.4.1	Number of occurrences of unavailability of a route set to a given destination .....	76
5.1.4.2	Duration of unavailability of a route set to a given destination .....	76
5.2	Measurements related to bearer control .....	77
5.2.1	Overview .....	77
5.2.2	Measurements related to the ATM AAL2 connection setup .....	77

5.2.2.1	Attempted AAL2 connection setup .....	77
5.2.2.2	Successful AAL2 connection setup .....	77
5.2.3	Measurements related to IP RTP connection .....	78
5.2.3.1	Attempted outgoing connection setup .....	78
5.2.3.2	Successful outgoing connection setup .....	78
5.2.3.3	Attempted incoming connection setup .....	78
5.2.3.4	Successful incoming connection setup .....	79
5.2.4	Measurements related to the User Plane (UP) In it .....	79
5.2.4.1	Attempted outgoing initial UP on the Nb interface .....	79
5.2.4.2	Successful outgoing initial UP on the Nb interface .....	79
5.2.4.3	Attempted incoming initial UP on the Nb interface .....	80
5.2.4.4	Successful incoming initial UP on the Nb interface .....	80
5.2.4.5	Attempted outgoing initial UP on the Iu interface .....	80
5.2.4.6	Successful outgoing initial UP on the Iu interface .....	81
5.2.4.7	Attempted incoming initial UP on the Iu interface .....	81
5.2.4.8	Successful incoming initial UP on the Iu interface .....	81
5.3	Bearer transport .....	82
5.3.1	Overview .....	82
5.3.2	Measurements related to Nb interface .....	82
5.3.2.1	Number of RTP messages received on Nb interface .....	82
5.3.2.2	Number of RTP messages sent on Nb interface .....	82
5.3.2.3	Number of RTP octets received on Nb interface .....	82
5.3.2.4	Number of RTP octets sent on Nb interface .....	83
5.3.2.5	Number of lost RTP messages on Nb interface .....	83
5.3.2.6	The maximum delay on Nb interface .....	83
5.3.2.7	The maximum delay jitter on Nb interface .....	84
5.3.2.8	The mean delay on Nb interface .....	84
5.3.2.9	The mean delay Jitter on Nb interface .....	84
5.3.3	AAL2 related measurements on Iu CS interface .....	85
5.3.3.1	Number of AAL2 packets received on IuCS interface .....	85
5.3.3.2	Number of AAL2 packets sent on IuCS interface .....	85
5.3.3.3	Octets of AAL2 packets received on IuCS interface .....	85
5.3.3.4	Octets of AAL2 packets sent on IuCS interface .....	85
5.3.4	RTP related measurements on Iu CS interface .....	86
5.3.4.1	Number of RTP messages received on Iu interface .....	86
5.3.4.2	Number of RTP messages sent on Iu interface .....	87
5.3.4.3	Number of RTP octets received on Iu interface .....	87
5.3.4.4	Number of RTP octets sent on Iu interface .....	87
5.3.4.5	Number of lost RTP packets on Iu interface .....	88
5.3.4.6	The maximum delay on Iu interface .....	88
5.3.4.7	The maximum delay jitter on Iu interface .....	88
5.3.2.8	The mean delay on Nb interface .....	89
5.3.2.9	The mean delay Jitter on Nb interface .....	89
5.3.5	Number of seized PVC link on Iu CS interface .....	89
5.4	Equipment resource .....	90
5.4.1	Overview .....	90
5.4.2	CPU Load .....	90
5.4.2.1	Mean CPU usage .....	90
5.4.3	Octets in MAC layer in MGW port .....	91
5.4.3.1	Number of octets sent on MAC layer in MGW port .....	91
5.4.3.2	Number of octets received on MAC layer in MGW port .....	91
5.4.4	H.248 message related measurements on Mc interface .....	92
5.4.4.1	Number of H.248 message received on Mc interface .....	92
5.4.4.2	Number of H.248 message sent on Mc interface .....	92
5.4.4.3	Number of H.248 message octets received on Mc interface .....	92
5.4.4.4	Number of H.248 message octets sent on Mc interface .....	93
5.4.5	Transcode .....	93
5.4.5.1	Number of failed calls caused by transcode resource .....	93
5.4.5.2	Number of attempted seized transcoder .....	93
5.5	User Plane services .....	94
5.5.1	Overview .....	94
5.5.2	Continuity Check (CC) .....	94

5.5.2.1	Number of seizure attempts for CC .....	94
5.5.2.2	Number of successful CC seizures .....	94
5.5.3	DTMF Sending and Detection (DTMF).....	95
5.5.3.1	Number of seizure attempts for DTMF.....	95
5.5.3.2	Number of successful DTMF seizures .....	95
5.5.4	Global Text Telephony (GTT).....	95
5.5.4.1	Number of seizure attempts for GTT .....	95
5.5.4.2	Number of successful GTT seizures.....	96
5.5.5	Media Frame Handler (MFH) .....	96
5.5.5.1	Number of seizure attempts for MFH .....	96
5.5.5.2	Number of successful MFH seizures .....	96
5.5.6	Multiparty Call (MPC) .....	97
5.5.6.1	Number of seizure attempts for MPC.....	97
5.5.6.2	Number of successful MPC seizures .....	97
5.5.7	Speech Coder (SC).....	97
5.5.7.1	Number of seizure attempts for SC.....	97
5.5.7.2	Number of successful SC seizures .....	98
5.5.8	Tone Sender or Line Test (TS) .....	98
5.5.8.1	Number of seizure attempts for TS.....	98
5.5.8.2	Number of successful TS seizures .....	98
6	Measurements related to the HLR .....	99
6.1	Equipment resource.....	99
6.1.1	Overview .....	99
6.1.2	CPU LOAD .....	99
6.1.2.1	Mean CPU usage.....	99
6.1.3	Subscribers related measurements .....	100
6.1.3.1	Subscribers in HLR .....	100
6.1.4	MTP3 signalling link related measurements .....	101
6.1.4.1	Number of unavailable times of MTP3 signalling link .....	101
6.1.4.2	Number of MSUs received on MTP3 signalling link .....	101
6.1.4.3	Number of MSUs sent on MTP3 signalling link.....	101
6.1.4.4	Number of octets received on MTP3 signalling link .....	102
6.1.4.5	Number of octets sent on MTP3 signalling link .....	102
6.1.4.6	Number of available MTP3 signalling link .....	102
6.1.4.7	Mean duration of unavailable MTP3 signalling link .....	103
<b>Annex A (informative):</b>	<b>Examples for "(n-1) out of n" approach .....</b>	<b>104</b>
A.1	Attempt/success/failure procedure measurements .....	104
A.2	GSM/UMTS combined measurements.....	104
	See 3GPP TS 32.404 bedded "(n-1) out of n" approaches .....	104
<b>Annex B (informative):</b>	<b>Top-Down Performance Measurement Definition Process.....</b>	<b>105</b>
<b>Annex C (normative):</b>	<b>Use cases for performance measurements defintion.....</b>	<b>106</b>
C.1	Use case of the Mean delay Jitter on Nb interface related measurements.....	106
C.2	Use case of the Mean delay Jitter on Nb interface related measurements.....	106
C.3	Use case of number of subscribers in VLR.....	106
C.4	Use case of Number of Handover Intra MSC-S.....	106
<b>Annex E (informative):</b>	<b>Use case for measurements .....</b>	<b>107</b>
E.1	Use case for Iucslink and Alink related MO/MT and traffic measurements.....	107
<b>Annex E (informative):</b>	<b>Change history.....</b>	<b>108</b>

---

## Foreword

This Technical Specification has been produced by the 3<sup>rd</sup> Generation Partnership Project (3GPP).

The contents of the present document are subject to continuing work within the TSG and may change following formal TSG approval. Should the TSG modify the contents of the present document, it will be re-released by the TSG with an identifying change of release date and an increase in version number as follows:

Version x.y.z

where:

- x the first digit:
  - 1 presented to TSG for information;
  - 2 presented to TSG for approval;
  - 3 or greater indicates TSG approved document under change control.
- y the second digit is incremented for all changes of substance, i.e. technical enhancements, corrections, updates, etc.
- z the third digit is incremented when editorial only changes have been incorporated in the document.

---

## Introduction

The present document is part of a TS-family covering the 3rd Generation Partnership Project; Technical Specification Group Services and System Aspects; Telecommunication Management; as identified below:

TS 32.401	Performance Management (PM); Concept and requirements
TS 52.402	Performance Management (PM); Performance measurements - GSM
TS 32.404	Performance Management (PM); Performance measurements - Definitions and template
TS 32.405	Performance Management (PM); Performance measurements Universal Terrestrial Radio Access Network (UTRAN)
TS 32.406	Performance Management (PM); Performance measurements Core Network (CN) Packet Switched (PS) domain
<b>TS 32.407</b>	<b>Performance Management (PM); Core Network (CN) Circuit Switched (CS) Domain; Performance measurements - UMTS and combined UMTS/GSM</b>
TS 32.408	Performance Management (PM); Performance measurements Teleservice
TS 32.409	Performance Management (PM); Performance measurements IP Multimedia Subsystem (IMS)

The present document is part of a set of specifications, which describe the requirements and information model necessary for the standardised Operation, Administration and Maintenance (OA&M) of a multi-vendor 3G-system.

During the lifetime of a 3G network, its logical and physical configuration will undergo changes of varying degrees and frequencies in order to optimise the utilisation of the network resources. These changes will be executed through network configuration management activities and/or network engineering, see 3GPP TS 32.600 [3].



Many of the activities involved in the daily operation and future network planning of a 3G network require data on which to base decisions. This data refers to the load carried by the network and the grade of service offered. In order to produce this data performance measurements are executed in the NEs, which comprise the network. The data can then be transferred to an external system, e.g. an Operations System (OS) in TMN terminology, for further evaluation. The purpose of the present document is to describe the mechanisms involved in the collection of the data and the definition of the data itself.

For Measurement definition template and Management of per cause measurements see 3GPP TS 32.404 [8]. Annexes A and B of 3GPP TS 32.404 [8] also apply to the present document.

---

# 1 Scope

The present document describes the CN CS measurements for UMTS and combined UMTS/GSM.

3GPP TS 32.401 [2] describes Performance Management concepts and requirements.

The present document is valid for all measurement types provided by an implementation of a UMTS network and combined UMTS/GSM network. These may be measurement types defined within the present document, measurements defined within other standards bodies, or vendor specific measurement types.

Only measurement types that are specific to CN CS UMTS or combined UMTS/GSM networks are defined within the present documents. I.e. vendor specific measurement types used in UMTS and combined UMTS/GSM networks. Some ATM or IP measurements defined here are only used for load carrying. The definition of the standard measurements is intended to result in comparability of measurement data produced in a multi-vendor network, for those measurement types that can be standardised across all vendors' implementations.

The structure of the present document is as follows:

- Header 1: Network Element (e.g. MSCServer related measurements);
- Header 2: Measurement function (e.g. handover measurements);
- Header 3: Measurements.

---

# 2 References

The following documents contain provisions which, through reference in this text, constitute provisions of the present document.

- References are either specific (identified by date of publication and/or edition number or version number) or non-specific.
- For a specific reference, subsequent revisions do not apply.
- For a non-specific reference, the latest version applies. In the case of a reference to a 3GPP document (including a GSM document), a non-specific reference implicitly refers to the latest version of that document *in the same Release as the present document*.

- [1] ITU-T Recommendation Q.2630: "AAL type 2 signalling protocol".
- [2] 3GPP TS 32.401: "Telecommunication management; Performance Management (PM); Concept and requirements".
- [3] 3GPP TS 32.600: "Telecommunication management; Configuration Management (CM); Concept and high-level requirements".
- [4] 3GPP TS 23.153: "Out of band transcoder control; Stage 2".
- [5] 3GPP TS 25.413: "UTRAN Iu interface Radio Access Network Application Part (RANAP) signalling".
- [6] ITU-T Recommendation Q.1902: "Bearer Independent Call Control protocol (Capability Set 2)".
- [7] ITU-T Recommendation Q.752: "Monitoring and measurements for Signalling System No. 7 networks".
- [8] 3GPP TS 32.404 "Performance Management (PM); Performance measurements - Definitions and template".
- [9] 3GPP TS 32.622: "Telecommunication management; Configuration Management (CM); Generic network resources Integration Reference Point (IRP): Network Resource Model (NRM)".

- [10] ITU-T Recommendation Q.723: "Telephone user part formats and codes".
- [11] 3GPP TS 23.018: "Basic call handling Technical Realization".
- [12] 3GPP TS 24.011: "Point-to-Point (PP) Short Message Service (SMS) support on Mobile Radio Interface".
- [13] 3GPP TS 52.402: "Telecommunication management; Performance Management (PM); Performance measurements - GSM".
- [14] 3GPP TS 24.008: "Mobile radio interface Layer 3 specification; Core network protocols; Stage 3".
- [15] GSM 04.08: "Digital cellular telecommunications system (Phase 2); Mobile radio interface; Layer 3 specification".
- [16] ITU-T Recommendation Q.763: "Signalling System No. 7 - ISDN User Part formats and codes".
- [17] 3GPP TS 09.02: "Mobile Application Part (MAP) Specification".
- [18] 3GPP TS 23.008: "Organization of subscriber data".
- [19] IETF RFC 2960: "Stream Control Transmission Protocol" at <ftp://ftp.rfc-editor.org/in-notes/rfc2960.txt>
- [20] 3GPP TS 32.742: "Telecommunication management; Configuration Management (CM); Signalling Transport Network (STN) interface Network Resource Model (NRM) Integration Reference Point (IRP): Information Service (IS)".
- [21] IETF RFC 1889: "*RTP: A Transport Protocol for Real-Time Applications*" at <ftp://ftp.rfc-editor.org/in-notes/rfc1889.txt>, Obsoleted by RFC 3550
- [22] IETF RFC 3550: "RTP: A Transport Protocol for Real-Time Applications" at <ftp://ftp.rfc-editor.org/in-notes/rfc3550.txt>
- [23] ITU-T Recommendation Q.753: "Signalling System No. 7 management functions MRVT, SRVT and CVT and definition of the OMASE-user" at <http://www.itu.int/rec/T-REC-Q.753/en>
- [24] ITU-T Recommendation Q.724: "Signalling System No. 7 - Telephone User parts, Signalling procedures".
- [25] 3GPP TS 23.014: "Support of Dual Tone Multi-Frequency signalling".
- [26] 3GPP TS 22.226: "Global Text Telephony; Stage 1".
- [27] ITU-T Recommendation E.182: "Application of tones and recorded announcements in telephone services".
- [28] 3GPP TS 25.415: "UTRAN Iu interface user plane protocols".
- [29] 3GPP TS 29.415: "Core network Nb interface user plane protocols".
- [30] ITU-T Recommendation I.254.1: "Multipart supplementary services: Conference calling (CONF)".
- [31] 3GPP TS 23.153: "Out of band transcoder control; Stage 2".
- [32] 3GPP TS 26.071: "Mandatory speech CODEC speech processing functions; AMR speech CODEC; General description".
- [33] 3GPP TS 26.090: "Mandatory speech CODEC speech processing functions; AMR speech CODEC; Transcoding functions".
- [34] 3GPP TS 23.009: "Handover procedures".

## 3 Measurement family and abbreviations

### 3.1 Measurements

The measurement names defined in the present document are all beginning with a prefix containing the measurement family name (MM attIntraVlrLU). This family name identifies all measurements which relate to a given functionality and it may be used for measurement administration (see 3GPP TS 32.401 [2]).

The list of families currently used in the present document is as follows:

- CC (measurements related to Call control Management).
- MM (measurements related to Mobility Management).
- SIG (measurements related to Signalling).
- EQPT (measurements related to Equipment resource).
- BC (measurements related to bearer control).
- BRT (measurements related to bearer transport).
- SC (measurements related to service control).

### 3.2 Abbreviations

For the purposes of the present document, the following abbreviations apply:

CEG	CircuitEndPointSubgroup
CN	Core Network
EM	(Network) Element Manager
MSC	Mobile services Switching Centre
MSU	Message Signal Unit
NE	Network Element
NM	Network Manager
OS	Operations System (EM, NM)
OSI	Open Systems Interconnection
PM	Performance Management
PVC	Permanent Virtual Connection
RNC	Radio Network Controller
UMTS	Universal Mobile Telecommunications System
UTRAN	Universal Terrestrial Radio Access Network

You can find below a list of abbreviations used within the measurement types for field E of the measurement template (see clause 3.3).

Acpt	Accept
Att	Attempt(s,ed)
Auth	Authentication
Avail	Available
Answ	Answer(ed)
Call	Call
Conn	Connection
CS	Circuit switched
Ctrl	Controlled
Fail	Fail(ed, ure)
HO	Handover
Inc	Incoming
Inter	Inter
Intra	Intra
LK	link

MM	Mobility Management
Nat	National
Netw	Network
Nbr	Number
Oct	Octet(s)
Out	Outgoing
Origi	Originate(ing,ed)
Pkt	Packet(s)
PS	Packet switched
Req	Request(s,ed)
Res	Resource
Setup	Setup
MSC-S	MSC or MSC SERVER
Msg	message
Sig	Signalling
Subs	Subscriber
Succ	Success(es,ful)
Termi	terminate(ed,ing)
UE	User Equipment
UTRAN	UTRAN
MSU	Message signal unit(s)
Vlr	VLR

## 4 Measurements related to the MSC Server

### 4.1 Call control management

#### 4.1.1 Overview

##### 4.1.1.1 Basic traffic model

The call control management clause defines measurements related to the network call establishment, MO/MT call control, inter MSC-S call control, etc. The traffic model using in this specification is depicted as follows.

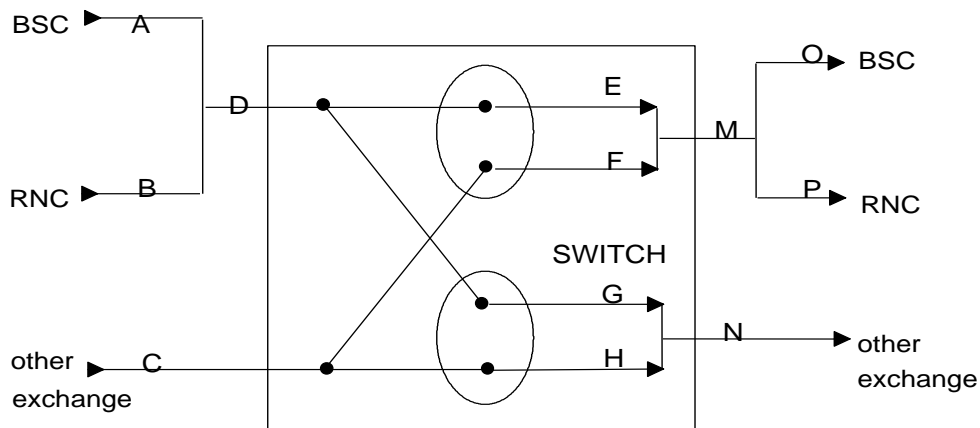

- A GSM Mobile Originating call
- B WCDMA mobile originating call
- C Incoming call
- D Mobile originating call
- E Internal call
- F Terminating incoming call
- G Originating outgoing call
- H Transit call
- M Mobile terminating call
- N Outgoing call
- O GSM mobile terminating call
- P WCDMA mobile terminating call

**Figure 1: Traffic model**

In figure 1,  $D = A + B$  ,  $M = E + F$ . The  $D/M$  can be calculated from other measurements.

### 4.1.1.2 Basic signalling flow

Figures below depict a basic MO/MT call procedure respectively. It should be noted that all the messages displayed in the following figures are introduced as illustrative information flow between different NEs, that is, they are NOT the exact message name when interworking. (It should also be noticed that different network versions, e.g. R99, R4, etc., may have signalling messages with different names.) For more information on each signalling message, please refer to 3GPP TS 23.018 [11].

Note that all message sequence charts in this clause are examples. All valid call establishment message sequences can be derived from the example message sequences and associated message pre-conditions.

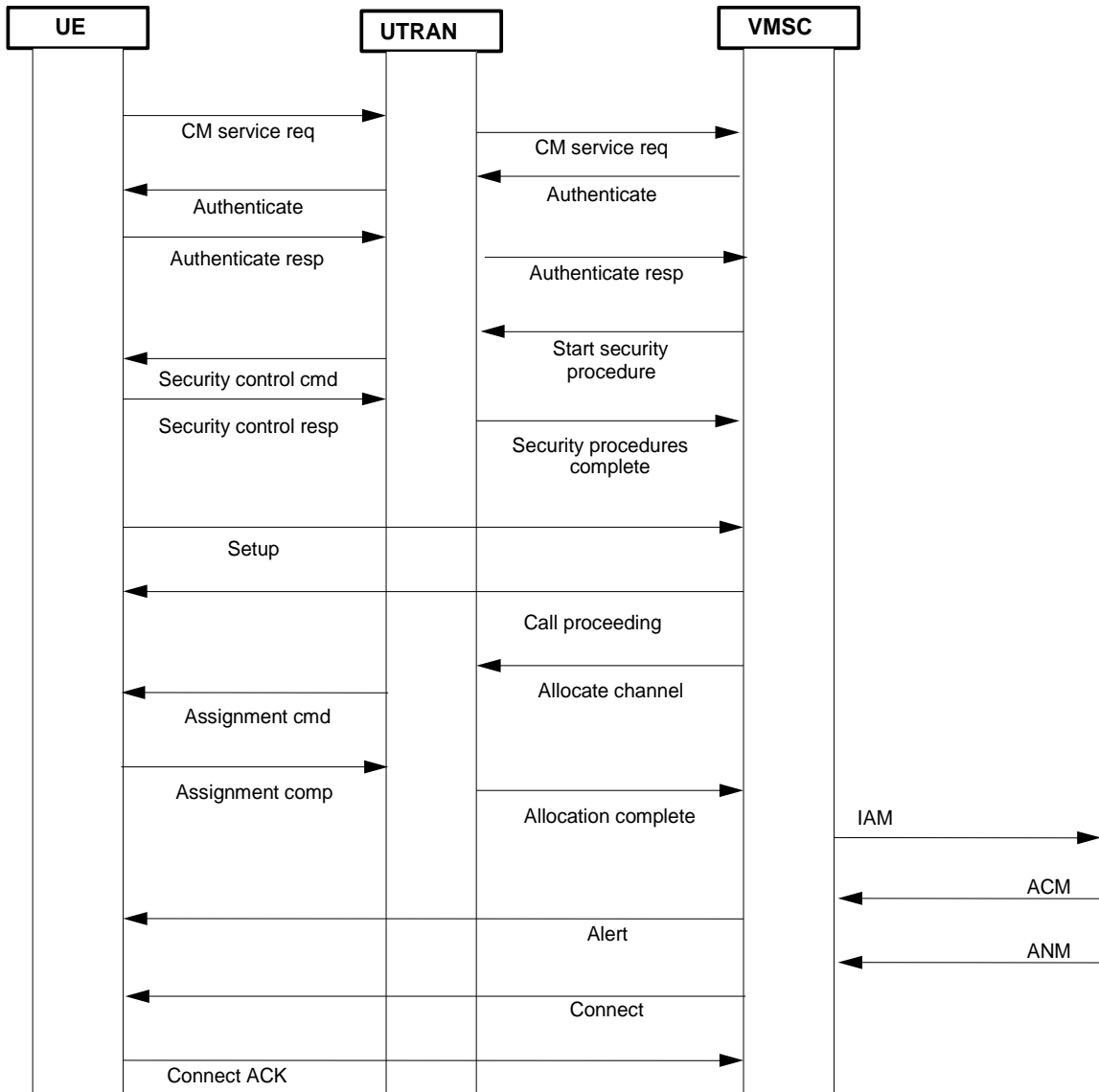

**Figure 2: Information flow for a basic Mobile Originated (MO) call**

### 4.1.2 MO/MT call related performance

This clause defines the measurements related to traffic model type A, B for mobile originating traffic and type O,P for mobile terminating traffic. The signalling flow for the MO and MT can be found in 3GPP TS 23.018 [ 11].

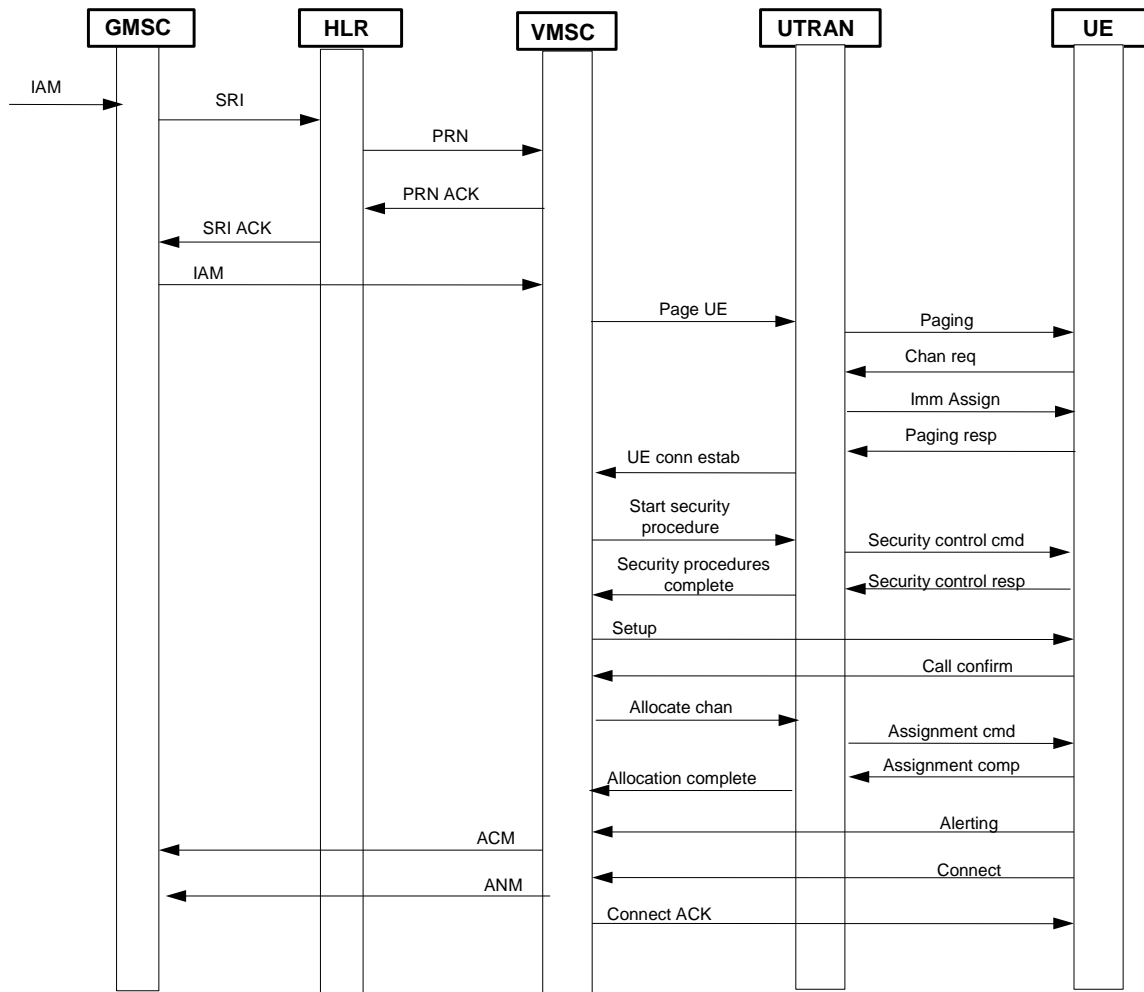

Figure 3: Information flow for a basic Mobile Terminated (MT) call



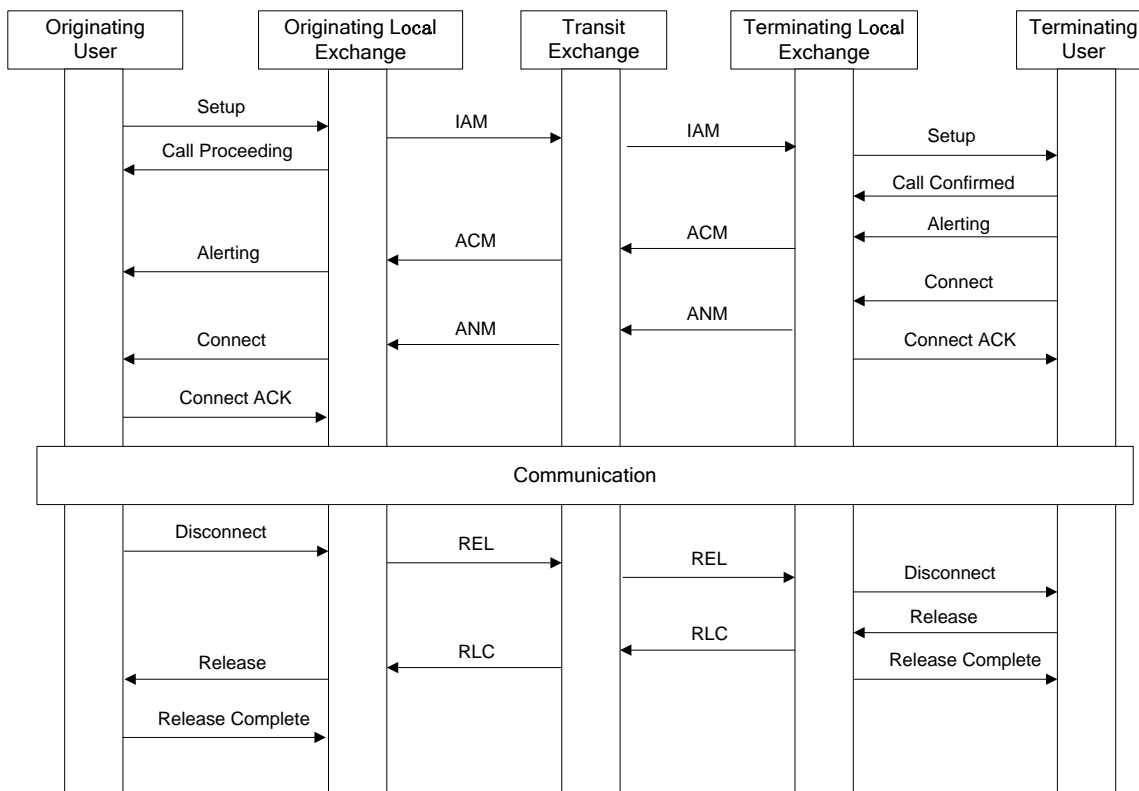

Figure 4: Information flow for a basic end to end call

4.1.2.1 MSC-S acknowledged originating calls

- a) This measurement provides the number of attempted calls acknowledged for originating traffic. The three measurement types defined in e) are subject to the "2 out of 3 approach".
- b) CC.
- c) On transmission by the MSC-S of a "Call Proceeding" message to the originating UE (3GPP TS 24.008 [6]).
- d) A single integer value per measurement type defined in e).
- e) CC.AttOrigCalls Combined (don't care);  
 CC.AttOrigCalls.G GSM;  
 CC.AttOrigCalls.U UMTS.

NOTE: only the GSM subcounter should be provided if the measured object is ALink.

- f) MSCServerFunction/VlrFunction.
- g) Valid for circuit switching.  
 ALink  
 IucsLink.
- h) GSM/UMTS.

#### 4.1.2.2 MSC-S acknowledged terminating calls

- a) This measurement provides the number of successful calls for MSC-S terminating traffic. The three measurement types defined in e) are subject to the "2 out of 3 approach".
- b) CC.
- c) On receipt of "Call Confirmed" message from the terminating UE (3GPP TS 24.008 [6]).
- d) A single integer value per measurement type defined in e).
- e) CC.SuccTermiCalls                      Combined(don't care);  
     CC.SuccTermiCalls.G                  GSM;  
     CC.SuccTermiCalls.U                  UMTS.

NOTE: only the GSM subcounter should be provided if the measured object is A link.

- f) MSCServerFunction/VlrFunction.  
     ALink  
     IucsLink.
- g) Valid for circuit switching.
- h) GSM/UMTS.

#### 4.1.2.3 Attempted mobile originating calls

- a) This measurement provides the number of mobile originating call attempts from the MSC-S's perspective. The three measurement types defined in e) are subject to the "2 out of 3 approach".
- b) CC.
- c) On receipt of "CM\_SERV\_REQ" message from the originating mobile, with service type 0001 or 0010. See 3GPP TS 24.008 [6].
- d) A single integer value per measurement type defined in e).
- e) CC.AttmobileOrigiCalls                  Combined(don't care);  
     CC.AttmobileOrigiCalls.G              GSM;  
     CC.AttmobileOrigiCalls.U              UMTS.

NOTE: only the GSM subcounter should be provided if the measured object is A link.

- f) MSCServerFunction/VlrFunction.  
     ALink  
     IucsLink.
- g) Valid for circuit switched traffic.
- h) GSM/UMTS.

#### 4.1.2.4 Successful mobile originating call

- a) This measurement provides the number of successful call for MSC-S mobile originating traffic. The three measurement types defined in e) are subject to the "2 out of 3 approach".
- b) CC.

- c) On transmission by the MSC-S of a "Alerting" message to the originating mobile (3GPP TS 24.008 [6]).
- d) A single integer value per measurement type defined in e).
- e) CC.SuccmobileOrigCalls            Combined(don't care);  
       CC.SuccmobileOrigCalls.G        GSM;  
       CC.SuccmobileOrigCalls.U        UMTS.

NOTE: only the GSM subcounter should be provided if the measured object is ALink.

- f) MSCServerFunction/VlrFunction.

ALink

IucsLink.

- g) Valid for circuit switching.
- h) GSM/UMTS.

#### 4.1.2.5 Answered mobile originating calls

- a) This measurement provides the number of answered calls for MSC-S mobile originating traffic. The three measurement types defined in e) are subject to the "2 out of 3 approach".
- b) CC.
- c) On receipt by the MSC-S of a "CONNECT ACKNOWLEDGE" message from the originating mobile, for the requested mobile originating call (3GPP TS 24.008 [6], ITU-T Recommendations Q.723 and Q.763).
- d) A single integer value per measurement type defined in e).
- e) CC.AnswMobileOrigCalls            Combined(don't care);  
       CC.AnswMobileOrigCalls.G        GSM;  
       CC.AnswMobileOrigCalls.U        UMTS.

NOTE: only the GSM subcounter should be provided if the measured object is ALink.

- f) MSCServerFunction/VlrFunction.

ALink

IucsLink.

- g) Valid for circuit switching.
- h) GSM/UMTS.

#### 4.1.2.6 Attempted mobile terminating calls

- a) This measurement provides the number of call attempted for UMTS mobile terminating traffic from MSC-S's perspective. The three measurement types defined in e) are subject to the "2 out of 3 approach".
- b) CC.
- c) On transmission by the MSC-S of a "SETUP" message to the called mobile, for the requested mobile terminating call. See 3GPP TS 24.008 [6].
- d) A single integer value per measurement type defined in e).
- e) CC.AttMobileTermiCalls            Combined(don't care);  
       CC.AttMobileTermiCalls.G        GSM;

CC.AttMobileTermiCalls.U UMTS.

NOTE: only the GSM subcounter should be provided if the measured object is ALink.

f) MSCServerFunction/VlrFunction.

ALink

IucsLink.

g) Valid for circuit switched traffic.

h) GSM/UMTS.

#### 4.1.2.7 Successful mobile terminating calls

a) This measurement provides the number of successful calls for mobile terminating traffic. The three measurement types defined in e) are subject to the "2 out of 3 approach".

b) CC.

c) On receipt by the MSC-S of an "ALERTING" message from the called mobile, for the requested mobile terminating call (3GPP TS 24.008 [6]).

d) A single integer value per measurement type defined in e).

e) CC.SuccMobileTermiCalls Combined(don't care);

CC.SuccMobileTermiCalls.G GSM;

CC.SuccMobileTermiCalls.U UMTS.

NOTE: only the GSM subcounter should be provided if the measured object is ALink.

f) MSCServerFunction/VlrFunction.

ALink

IucsLink.

g) Valid for circuit switching.

h) GSM/UMTS.

#### 4.1.2.8 Answered mobile terminating calls

a) This measurement provides the number of answered calls for mobile terminating traffic. The three measurement types defined in e) are subject to the "2 out of 3 approach".

b) CC.

c) On transmission by the MSC-S of a "CONNECTION ACKNOWLEDGE" message to the called mobile, for the requested mobile terminating call (3GPP TS 24.008 [6]).

d) A single integer value per measurement type defined in e).

e) CC.AnsMobileTermiCalls Combined(don't care);

CC.AnsMobileTermiCalls.G GSM;

CC.AnsMobileTermiCalls.U UMTS.

NOTE: only the GSM subcounter should be provided if the measured object is ALink.

f) MSCServerFunction/VlrFunction.

ALink

IucsLink.

- g) Valid for circuit switched traffic.
- h) GSM/UMTS.

#### 4.1.2.9 Failed mobile calls caused by subscribers in originating MSC-S for Inter-MSC call

NOTE 1: Since TUP does not differentiate cause value, it is not included in clauses 4.1.1.9, 4.1.2.10 and 4.1.2.11.

NOTE 2: Since ISUP does not differentiate cause value clearly, the causes of user busy, no-answering and user refused are not included here.

- a) This measurement provides the number of failed mobile calls caused by subscribers. This measurement is valid to originating MSC-S.
- b) CC.
- c) Calling party releasing the call after alerting: On Receipt of "DISCONNECT" (cause #16 "normal call clearing") from calling party after transmission of "ALERTING" to calling party in the case of Inter-MSC call.  
  
Calling party releasing the call before alerting: On Receipt of "DISCONNECT" (cause #16 "normal call clearing") from calling party when "Network call states" of calling party is in N0.2~N0.6,N1,N3 in the case of Inter-MSC call.
- d) Each measurement is an integer value. The number of measurements is equal to the number of causes plus a possible sum value identified by the .sum suffix.
- e) CC.OrigInterMSCFailedbySubs.OrigRel:
  - number of failed calls caused by calling party releasing the call before alerting in the case of Inter-MSC call.CC.OrigInterMSCFailedbySubs.AlertRel:
  - number of failed calls caused by calling party releasing the call after alerting in the case of Inter-MSC call.
- f) MSCServerFunction/VlrFunction.
- g) Valid for circuit switched traffic.
- h) GSM/UMTS.

#### 4.1.2.10 Failed mobile calls caused by subscribers in terminating MSC-S for Inter-MSC call

- a) This measurement provides the number of failed mobile calls caused by subscribers. This measurement is valid to terminating MSC-S.
- b) CC.
- c) Calling party releasing the call after alerting: On transmission of "DISCONNECT"(cause #16 "normal call clearing") to called party after receipt of "ALERTING" from called party in the case of Inter-MSC call.
- Calling party releasing the call before alerting: On receipt of "REL"(cause value=normal unspecified or normal call clearing) from originating MSC-S when Network call states of called party is in N0.1,N6,N9 in the case of Inter-MSC call.
- User busy: Called Party is Pre-defined "busy" in VLR when receipt of "IAM" in the case of Inter-MSC call.
  - No answer from the user: When T301 expires in the case of Inter-MSC call.
  - User Refused: When receipt of "DISCONNECT"( cause #17 "user busy" or cause #21 "call rejected") from called party after receipt of "ALERTING" from called party in the case of Inter-MSC call.
- d) Each measurement is an integer value. The number of measurements is equal to the number of causes plus a possible sum value identified by the .sum suffix.
- e) CC.TerminInterMSCFailedbySubs.UserBusy:
- number of failed calls caused by user-busy in the case of Inter-MSC call.
- CC.TerminInterMSCFailedbySubs.NoAnsw:
- number of failed calls caused by no-answering in the case of Inter-MSC call.
- CC.TerminInterMSCFailedbySubs.Ref:
- number of failed calls caused by UDUB or user rejection in the case of Inter-MSC call.
- CC.TerminInterMSCFailedbySubs.TerminRel:
- number of failed calls caused by calling party releasing the call before alerting in the case of Inter-MSC call.
- CC.TerminInterMSCFailedbySubs.AlertRel:
- number of failed calls caused by calling party releasing the call after alerting in the case of Inter-MSC call.
- f) MSCServerFunction/VlrFunction.
- g) Valid for circuit switched traffic.
- h) GSM/UMTS.

#### 4.1.2.11 Failed mobile calls caused by subscribers in MSC-S for Intra-MSC call

- a) This measurement provides the number of failed mobile calls caused by subscribers. This measurement is valid to the MSC-S in which called party and calling party both registered.

NOTE: Since both called party and calling party registered in one MSC, the call could be thought of one call. This counter's trigger will be described as terminating MSC point of view.

- b) CC.

- c) Calling party releasing the call after alerting: On Receipt of "DISCONNECT" (cause #16 "normal call clearing") from calling party after transmission of "ALERTING" to the calling party in the case of Intra-MSC call.

Calling party releasing the call before alerting: On Receipt of "DISCONNECT" (cause #16 "normal call clearing") from calling party when Network call states of called party is in N0.1,N6,N9 in the case of Intra-MSC call.

- User busy: Called Party is Pre-defined "busy" in VLR when the call is setting up in the case of Intra-MSC call.
  - No answer from the user: When T301 expires in the case of Intra-MSC call.
  - User Refused: When receipt of "DISCONNECT" ( cause #17 "user busy" or cause #21 "call rejected") from called party after receipt of "ALERTING" from called party in the case of Intra-MSC call.
- d) Each measurement is an integer value. The number of measurements is equal to the number of causes plus a possible sum value identified by the .sum suffix.
- e) CC.IntraMSCFailedbySubs:
- total of failed calls caused by users.
- CC.IntraMSCFailedbySubs.UserBusy:
- number of failed calls caused by user-busy in the case of Intra-MSC call.
- CC.IntraMSCFailedbySubs.OrigRel:
- number of failed calls caused by calling party releasing the call before alerting in the case of Intra-MSC call.
- CC.IntraMSCFailedbySubs.AlertRel:
- number of failed calls caused by calling party releasing the call after alerting in the case of Intra-MSC call.
- CC.IntraMSCFailedbySubs.NoAnsw:
- number of failed calls caused by no-answering in the case of Intra-MSC call.
- CC.IntraMSCFailedbySubs.Rej:
- number of failed calls caused by UDUB or user rejection in the case of Intra-MSC call.

- f) MSCServerFunction/VlrFunction.

- g) Valid for circuit switched traffic.

- h) GSM/UMTS.

### 4.1.3 MSC-S (BICC) call related performance

The Performance measurements defined in this clause is related to the MSC-S call performance which connects to other MSC-S via BICC over IP. The related traffic model is Traffic Model C type and D in clause 4.1.1.1. The measurements defined in this clause can be applied to CMN also.

**Editor's note: NcLink need to be added to CN NRM.**

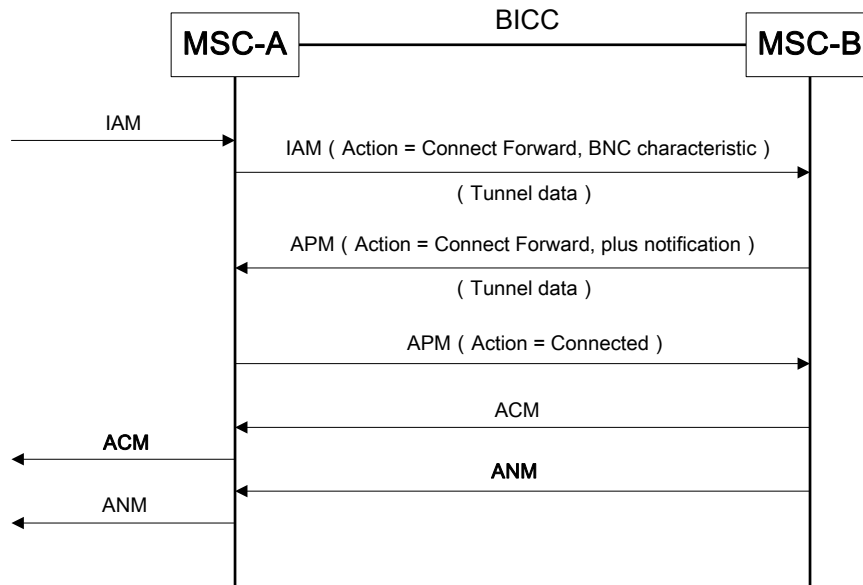

**Figure 5: Information flow between MSC-Ss for a basic call**

#### 4.1.3.1 Attempted incoming calls

- This measurement provides the number of attempted incoming calls from MSC-S.
- CC.
- On receipt by the MSC-S of an "IAM" message from a given MSC-S (ITU-T Recommendation Q.1902).
- A single integer value.
- CC.AttIncCalls                      Combined.
- NcLink.
- Valid for circuit switched traffic.
- GSM/UMTS.



#### 4.1.3.2 Successful incoming calls

- a) This measurement provides the number of successful incoming calls from a given MSC-S.
- b) CC.
- c) On transmission by the MSC-S of an "ACM" with "Called party's status indicator = subscriber free" or "CON" or an "CPG" with "Event Information = ALERTING" (ITU-T Recommendation Q.1902).

NOTE: The "CON" message shall be the trigger when "ACM" message is not sent.

- d) A single integer value.
- e) CC.SuccIncCalls                      Combined.
- f) NcLink.
- g) Valid for circuit switched traffic.
- h) GSM/UMTS.

#### 4.1.3.3 Answered incoming calls

- a) This measurement provides the number of answered incoming calls from a given MSC-S.
- b) CC.
- c) On transmission by the MSC-S of an "ANM" or "CON" message to a given MSC-S (ITU-T Recommendation Q.1902).

NOTE: The "CON" message shall be the trigger when "ACM" message has already been sent.

- d) A single integer value.
- e) CC.AnswIncCalls                      Combined.
- f) NcLink.
- g) Valid for circuit switched traffic.
- h) GSM/UMTS.

#### 4.1.3.4 Attempted outgoing calls

- a) This measurement provides the number of attempted outgoing calls to MSC-S.
- b) CC.
- c) On transmission by the MSC-S of an "IAM" messages to a given MSC-S (ITU-T Recommendation Q.1902).
- d) A single integer value.
- e) CC.AttOutCalls                      Combined.
- f) NcLink.
- g) Valid for circuit switched traffic.
- h) GSM/UMTS.

#### 4.1.3.5 Successful outgoing calls

- a) This measurement provides the number of successful outgoing calls to MSC-S.
- b) CC.
- c) On receipt by the MSC-S of an "ACM" with "Called party's status indicator = subscriber free" or "CON" or an "CPG" with "Event Information = ALERTING" (ITU-T Recommendation Q.1902).

NOTE: The "CON" message shall be the trigger when "ACM" message has already been sent.

- d) A single integer value.
- e) CC.SuccOutCalls                      Combined.
- f) NcLink.
- g) Valid for circuit switched traffic.
- h) GSM/UMTS.

#### 4.1.3.6 Answered outgoing calls

- a) This measurement provides the number of answered outgoing calls from MSC-S.
- b) CC.
- c) On receipt by the MSC-S of an "ANM" or "CON" message from a given MSC-S (ITU-T Recommendation Q.1902).

NOTE: The "CON" message shall be the trigger when "ACM" message has already been sent.

- d) A single integer value.
- e) CC.AnswOutCalls                      Combined.
- f) NcLink.
- g) Valid for circuit switched traffic.
- h) GSM/UMTS.

## 4.1.4 Trunk group (TDM) call related performance

The Performance measurements defined in this clause is related to TDM related call performance.

**Editor's note: CircuitEndPointSubgroup need to be added to CN NRM.**

### 4.1.4.1 Seized outgoing calls per trunk group

- a) This measurement provides the number of seized outgoing calls to adjacent network per trunk group. It's valid to uni-directional and bi-directional trunk group.
- b) CC.
- c) On transmission of "IAM" message (ITU-T Recommendation Q.764, clauses 2.1.1 and 2.1.2) or "IAM/IAI" message (ITU-T Recommendation Q.724, table 1).
- d) A single integer value.
- e) CC.SeizedOutCEG                      Combined.
- f) CircuitEndPointSubgroup.
- g) Valid for circuit switched traffic.
- h) GSM/UMTS.

### 4.1.4.2 Successful outgoing calls per trunk group

- a) This measurement provides the successful number of seized outgoing calls to adjacent network per trunk. It's valid to uni-directional and bi-directional trunk group.
- b) CC.
- c) On receipt by the MSC-S of an "ACM" with "Called party's status indicator = subscriber free" or CON or a "CPG" with "Event Information = ALERTING" (ITU-T Recommendations Q.762 and Q.763).
- d) A single integer value.
- e) CC.SuccOutCallsCEG                      Combined.
- f) CircuitEndPointSubgroup.
- g) Valid for circuit switched traffic.
- h) GSM/UMTS.

### 4.1.4.3 Answered outgoing calls per trunk group

- a) This measurement provides the number of answered outgoing calls to adjacent network per trunk. It's valid to uni-directional and bi-directional trunk group.
- b) CC.
- c) On receipt by the MSC-S of an "ANM" or "CON" message from a given adjacent MSC-S (ITU-T Recommendation Q.1902).
- d) A single integer value.
- e) CC.AnswOutCallsCEG                      Combined.
- f) CircuitEndPointSubgroup.
- g) Valid for circuit switched traffic.
- h) GSM/UMTS.

#### 4.1.4.4 Number of trunk group overflow

- a) This measurement provides the number of trunk overflow. It's valid to uni-directional and bi-directional trunk group.
- b) CC.
- c) When no trunk is available.
- d) A single integer value.
- e) CC.NbrCEGOverflow Combined.
- f) CircuitEndPointSubgroup.
- g) Valid for circuit switched traffic.
- h) GSM/UMTS.

#### 4.1.4.5 Seized incoming calls per trunk group

- a) This measurement provides number of seized incoming calls per trunk group.
- b) CC.
- c) On receipt by the MSC-S of an "IAM" or "IAI" message (ITU-T Recommendations Q.723 and Q.763).
- d) A single integer value.
- e) CC.SuccIncSeizuresCEG Combined.
- f) CircuitEndPointSubgroup.
- g) Valid for circuit switched traffic.
- h) GSM/UMTS.

#### 4.1.4.6 Time of all trunks unavailable

- a) The measurement provides the total duration of trunk unavailable in seconds for outgoing calls, or for bi-directional trunk groups for both, incoming and outgoing calls.
- b) DER (n=1).
- c) This measurement starts when no circuit is available and stops when there is an available circuit.
- d) A single integer value.
- e) CC.CEGUnavailDuration Combined (don't care).
- f) CircuitEndPointSubgroup.
- g) Valid for circuit switched traffic.
- h) GSM/UMTS.

#### 4.1.4.7 Successful incoming calls per trunk group

- a) This measurement provides the number of successful incoming calls per trunk group. It's valid to uni-directional and bi-directional trunk group.
- b) CC.
- c) On transmission by the MSC-S of an "ACM" with "Called party's status indicator = subscriber free" or CON or a "CPG" with "Event Information = ALERTING" (ITU-T Recommendations Q.762 and Q.763).

- d) A single integer value.
- e) CC.SuccIncCallsCEG                      Combined.
- f) CircuitEndPointSubgroup.
- g) Valid for circuit switched traffic.
- h) GSM/UMTS.

#### 4.1.4.8          Answered incoming call per trunk group

- a) This measurement provides the number of answered incoming calls from a given adjacent MSC-S per trunk group.
- b) CC.
- c) On transmission by the MSC-S of an "ANM" or "CON" message to a given adjacent MSC-S (ITU-T Recommendation Q.1902).

NOTE:    The "CON" message shall be the trigger when ACM message has already been sent.

- d) A single integer value.
- e) CC.AnswIncCallsCEG                      Combined.
- f) CircuitEndPointSubgroup.
- g) Valid for circuit switched traffic.
- h) GSM/UMTS.

## 4.1.5 Call establishment quality of service

### 4.1.5.1 UE call established time

- a) This measurement provides the mean time during each granularity period for UEs to establish connection. The three measurement types defined in e) are subject to the "2 out of 3 approach".
- b) DER (n=1).
- c) This measurement is obtained by accumulating the time intervals for each successful UE call establishment between the receipt by the MSC server of a " CM SERVICE REQUEST " message to establish a call for UE, and corresponding " ALERTING " message for successfully established UE call over a granularity period using DER, see GSM 04.08 [15] and 3GPP TS 24.008 [14]. This end value of the time will then be divided by the number of successfully established call numbers observed in the granularity period to give the arithmetic mean, the accumulator shall be reinitialised at the beginning of each granularity period.
- d) A real value(in seconds) per measurement type defined in e).
- e)
 

CC.DurOfCallEsta	Combined(don't care).
CC.DurOfCallEsta.G	GSM.
CC.DurOfCallEsta.U	UMTS.
- f) MSCServerFunction/VlrFunction.
- g) Valid for circuit switched traffic.
- h) GSM/UMTS.

## 4.1.6 Traffic related performance

### 4.1.6.1 Successful incoming call traffic

NOTE: If TUP is used, no need to differentiate voice and data.

- a) This measurement provides the successful incoming originating traffic from MSC-S's perspective. The three measurement types defined in e) are subject to the "2 out of 3 approach".
- b) DER(n=1).
- c) This measurement is obtained by accumulating the time intervals for all successful UEs establishment between the time sending transmission ""ACM" message" to and the corresponding time on receipt of corresponding release message ""CLF or CBK or REL"" over a granularity period using DER (See GSM 04.08 [15], 3GPP TS 24.008 [14], ITU-T Recommendation Q.763). This end value of the time will then be calculated as ERLANG. The accumulator shall be reinitialised at the beginning of each granularity period. (GSM 04.08 [15], 3GPP TS 24.008 [14], ITU-T Recommendation Q.763).
- d) A real value per measurement type defined in e). (Unit: ERLANG).
- e)
 

CC.SuccIncCallTraf
CC.SuccIncCallTraf.Voice
CC.SuccIncCallTraf.Data
- f) MSCServerFunction/VlrFunction.
- g) Valid for circuit switched traffic.
- h) GSM/UMTS.

#### 4.1.6.2 Answered incoming call traffic

NOTE: If TUP is used, no need to differentiate voice and data.

- a) This measurement provides the successful incoming originating traffic from MSC-S's perspective. The three measurement types defined in e) are subject to the "2 out of 3 approach".
- b) DER(n=1).
- c) This measurement is obtained by accumulating the time intervals for all successful UEs establishment between the transmission "ANM/ANC/ANN" message and the receipt of corresponding release message "CLF or CBK or REL" (see ITU-T Recommendations Q.723 and Q.763, 3GPP TS 24.008 [14]) over a given granularity period. The final result should be calculated to ERLANG. The accumulator shall be reinitialised at the beginning of each granularity period.
- d) A real value per measurement type defined in e). (Unit: ERLANG).
- e)
 

CC.AnswIncCallTraf	Mean Duration of Answered Incoming Call.
CC.AnswIncCallTraf.Voice	Mean Duration of Answered voice Incoming Call.
CC.AnswIncCallTraf.Data	Mean Duration of Answered CS data Incoming Call.
- f) MSCServerFunction/VlrFunction.
- g) Valid for circuit switched traffic.
- h) GSM/UMTS.

#### 4.1.6.3 Successful mobile originating call traffic

- a) This measurement provides the successful mobile originating incoming traffic from MSC-S's perspective. The three measurement types defined in e) are subject to the "n-1 out of n approach".
- b) DER(n=1).
- c) This measurement is obtained by accumulating the time intervals for all successful UEs establishment between the transmission "ALERTING" message and the receipt of corresponding release message "CLEAR COMMAND" or IU RELEASE COMMAND" over a given granularity period. (see ITU-T Recommendations Q.723 and Q.763, 3GPP TS 24.008) The final result should be calculated to ERLANG. The accumulator shall be reinitialised at the beginning of each granularity period.
- d) A real value per measurement type defined in e).(Unit: ERLANG).
- e)
 

CC.SuccOrigCallTraf	Holding Traffic Successful Outgoing Call.	
CC.SuccOrigCallTraf.Voice.G	GSM	Holding Traffic Successful Outgoing Call of Voice.
CC.SuccOrigCallTraf.Voice.U	UMTS.	
CC.SuccOrigCallTraf.Data.G	GSM	Holding Traffic Successful Outgoing Call of Data.
CC.SuccOrigCallTraf.Data.U	UMTS.	

NOTE: only the GSM subcounter should be provided if the measured object is ALink.

- f) MSCServerFunction/VlrFunction.
  - ALink
  - IucsLink.
- g) Valid for circuit switched traffic.
- h) GSM/UMTS.

#### 4.1.6.4 Answered mobile originating call traffic

- a) This measurement provides the answered mobile originating incoming traffic from MSC-S's perspective. The three measurement types defined in e) are subject to the "n-1 out of n approach".
- b) DER(n=1).
- c) This measurement is obtained by accumulating the time intervals for all successful UEs establishment between the transmission "CONNECT ACK" and the receipt of corresponding "CLEAR COMMAND" or IU RELEASE COMMAND" message over a given granularity period. The final result should be calculated to ERLANG (ITU-T Recommendations Q.723 and Q.763, 3GPP TS 24.008). The accumulator shall be reinitialised at the beginning of each granularity period.
- d) A real value per measurement type defined in e). (Unit: ERLANG).
- e) CC.AnswOrigCallTraf                      Traffic of Answered Outgoing Call.  
     CC.AnswOrigCallTraf.Voice.G    GSM    Traffic of Answered Outgoing Call of Voice.  
     CC.AnswOrigCallTraf.Voice.U    UMTS.  
     CC.AnswOrigCallTraf.Data.G    GSM    Traffic of Answered Outgoing Call of Data.  
     CC.AnswOrigCallTraf.Data.U    UMTS.

NOTE: only the GSM subcounter should be provided if the measured object is ALink.

- f) MSCServerFunction/VlrFunction.  
     ALink  
     IucsLink.
- g) Valid for circuit switched traffic.
- h) GSM/UMTS.

#### 4.1.6.5 Successful Mobile terminating call traffic

- a) This measurement provides the successful mobile terminating call traffic handled by the MSC-S. The three measurement types defined in e) are subject to the "n-1 out of n approach".
- b) DER(n=1).
- c) This measurement is obtained by accumulating the time intervals for all successful call establishment between the time receipt of the "ALERTING" and the corresponding "RELEASE COMPLETE" message over a given granularity period. The final result should be calculated to ERLANG. The accumulator shall be reinitialised at the beginning of each granularity period.
- d) A real value per measurement type defined in e). (Unit: ERLANG).
- e) CC.SuccTermiCallTraf                      GSM/UMTS    Holding traffic successful terminating call.  
     CC.SuccTermiCallTraf.Voice.G    GSM            Holding traffic Successful terminating call of voice.  
     CC.SuccTermiCallTraf.Voice.U    UMTS.  
     CC.SuccTermiCallTraf.Data.G    GSM            Holding traffic successful terminating call of Data.  
     CC.SuccTermiCallTraf.Data.U    UMTS.

NOTE: only the GSM subcounter should be provided if the measured object is ALink.

- f) MSCServerFunction/VlrFunction.  
     ALink



IucsLink.

- g) Valid for circuit switched traffic.
- h) GSM/UMTS.

#### 4.1.6.6 Answered Mobile terminating call traffic

- a) This measurement provides the answered mobile terminating call traffic handled by the MSC-S. The three measurement types defined in e) are subject to the "n-1 out of n approach".
- b) DER(n=1).
- c) This measurement is obtained by accumulating the time intervals for all answered call establishment between the time receipt of the "CONNECT ACKNOWLEDGE" and the corresponding "RELEASE COMPLETE" message over a given granularity period. The final result should be calculated to ERLANG. The accumulator shall be reinitialised at the beginning of each granularity period.
- d) A real value per measurement type defined in e). (Unit: ERLANG).
- e) CC.AnswTermiCallTraf                      Holding traffic answered terminating call.  
     CC.AnswTermiCallTraf.Voice.G    GSM    Holding traffic answered terminating call of voice.  
     CC.AnswTermiCallTraf.Voice.U    UMTS.  
     CC.AnswTermiCallTraf.Data.G    GSM    Holding traffic answered terminating call of Data.  
     CC.AnswTermiCallTraf.Data.U    UMTS.

NOTE: only the GSM subcounter should be provided if the measured object is ALink.

- f) MSCServerFunction/VlrFunction.  
     ALink  
     IucsLink.
- g) Valid for circuit switched traffic.
- h) GSM/UMTS.

#### 4.1.6.7 Successful outgoing traffic

NOTE: If TUP is used, no need to differentiate voice and data.

- a) This measurement provides the successful outgoing traffic from MSC-S's perspective. The three measurement types defined in e) are subject to the "2 out of 3 approach".
- b) DER(n=1).
- c) This measurement is obtained by accumulating the time intervals for all successful UEs establishment between the transmission "ACM" and the corresponding receipt of "CLF or CBK or REL" message over a given granularity period. This end value of this time will then be calculated as ERLANG. The accumulator shall be reinitialised at the beginning of each granularity period. (GSM 04.08, 3GPP TS 24.008).
- d) A real value per measurement type defined in e). (Unit: ERLANG).
- e) CC.SuccOutCallTraf                      Holding Traffic Successful Internal Call.  
     CC.SuccOutCallTraf.Voice            Holding Traffic Successful Internal Call of Voice.  
     CC.SuccOutCallTraf.Data            Holding Traffic Successful Internal Call of Data.
- f) MSCServerFunction/VlrFunction.

- g) Valid for circuit switched traffic.
- h) GSM/UMTS.

#### 4.1.6.8 Answered outgoing traffic

NOTE: If TUP is used, no need to differentiate voice and data.

- a) This measurement provides the answered outgoing traffic from MSC-S's perspective. The three measurement types defined in e) are subject to the "2 out of 3 approach".
- b) DER(n=1).
- c) This measurement is obtained by accumulating the time intervals for all successful UEs establishment between the transmission "ANM/ANC/ANN" and the corresponding receipt of "CLF or CBK or REL" message over a given granularity period. This end value of the time will then be calculated as ERLANG. The accumulator shall be reinitialised at the beginning of each granularity period. (GSM 04.08, 3GPP TS 24.008).
- d) A real value per measurement type defined in e). (Unit: ERLANG).
- e)
 

CC.AnswOutCallTraf.	Traffic of Answered Internal Call.
CC.AnswOutCallTraf.Voice	Traffic of Answered Internal Call of Voice.
CC.AnswOutCallTraf.Data	Traffic of Answered Internal Call of Data.
- f) MSCServerFunction/VlrFunction.
- g) Valid for circuit switched traffic.
- h) GSM/UMTS.

#### 4.1.6.9 Successful transit call traffic

- a) This measurement provides the successful exchange (or transfer) traffic from MSC-S's perspective. The three measurement types defined in e) are subject to the "2 out of 3 approach".
- b) DER(n=1).
- c) This measurement is obtained by accumulating the time intervals for all successful UEs establishment, after having received of "ACM" message from terminating MSC-S, between the forwarding ("ACM") message to the origination MSC-S and the corresponding transmission "CLR or REL" message to terminating message, or transmission "CBK or REL" to originating MSC-S over a given granularity period. This end value of this time will then be calculated as ERLANG. The accumulator shall be reinitialised at the beginning of each granularity period. (GSM 04.08, 3GPP TS 24.008).
- d) A real value per measurement type defined in e). (Unit: ERLANG).
- e)
 

CC.SuccTransCallTraf	Holding Traffic Successful Transferred Call.
CC.SuccTransCallTraf.Voice	Holding Traffic of Successful Transferred Call of Voice.
CC.SuccTransCallTraf.Data	Holding Traffic of Successful Transferred Call of Data.
- f) MSCServerFunction/VlrFunction.
- g) Valid for circuit switched traffic.
- h) GSM/UMTS.

#### 4.1.6.10 Answered transit call traffic

- a) This measurement provides the answered exchange (or transfer) traffic from MSC-S's perspective. The three measurement types defined in e) are subject to the "2 out of 3 approach".
- b) DER(n=1).
- c) This measurement is obtained by accumulating the time intervals for all answered call establishment, after having received of "ANM" or "CON" message from terminating MSC-S and the corresponding transmission "CLR or REL" message to terminating message, or transmission "CBK or REL" to originating MSC-S over a given granularity period. This end value of the time will then be calculated as ERLANG. The accumulator shall be reinitialised at the beginning of each granularity period. (GSM 04.08, 3GPP TS 24.008).
- d) A real value per measurement type defined in e). (Unit: ERLANG).
- e) CC.AnswTransCallTraf                      Traffic of Answered Transferred Call.  
    CC.AnswTransCallTraf.Voice            Traffic of Answered Transferred Call of Voice.  
    CC.AnswTransCallTraf.Data            Traffic of Answered Transferred Call of Data.
- f) MSCServerFunction/VlrFunction.
- g) Valid for circuit switched traffic.
- h) GSM/UMTS.

#### 4.1.6.11 Seized outgoing call traffic per trunk group

- a) This measurement provides outgoing traffic per trunk group. It is valid to uni-directional and bi-directional trunk group.
- b) DER(n=1).
- c) This measurement is obtained by accumulating the time intervals for all successful call establishment between the transmission "IAM or IAI" and the corresponding receipt of ("CLF or REL") or ("CBK or REL") message over a given granularity period. This end value of this time will then be calculated as ERLANG. The accumulator shall be reinitialised at the beginning of each granularity period. (GSM 04.08, 3GPP TS 24.008).
- d) A real value (Unit: ERLANG).
- e) CC.SuccOutSeizureTraffic CEG.
- f) CircuitEndPointSubgroup.
- g) Valid for circuit switched traffic.
- h) GSM/UMTS.

#### 4.1.6.12 Seized incoming call traffic per trunk group

- a) This measurement provides incoming traffic per trunk group. It is valid to uni-directional and bi-directional trunk group.
- b) DER (n=1).
- c) This measurement is obtained by accumulating the time intervals for all successful UEs establishment between the reception of "IAM or IAI" and the corresponding transmission of ("CLF or REL") or ("CBK or REL") message over a given granularity period. This end value of this time will then be calculated as ERLANG. The accumulator shall be reinitialised at the beginning of each granularity period. (GSM 04.08, 3GPP TS 24.008).
- d) A real value unit: ERLANG.
- e) CC.SuccIncSeizureTrafficTG      Combined.
- f) CircuitEndPointSubgroup.
- g) Valid for circuit switched traffic.
- h) GSM/UMTS.

## 4.1.7 Paging related performance

For information on the signalling messages, please refer to 3GPP TS 23.018 [11].

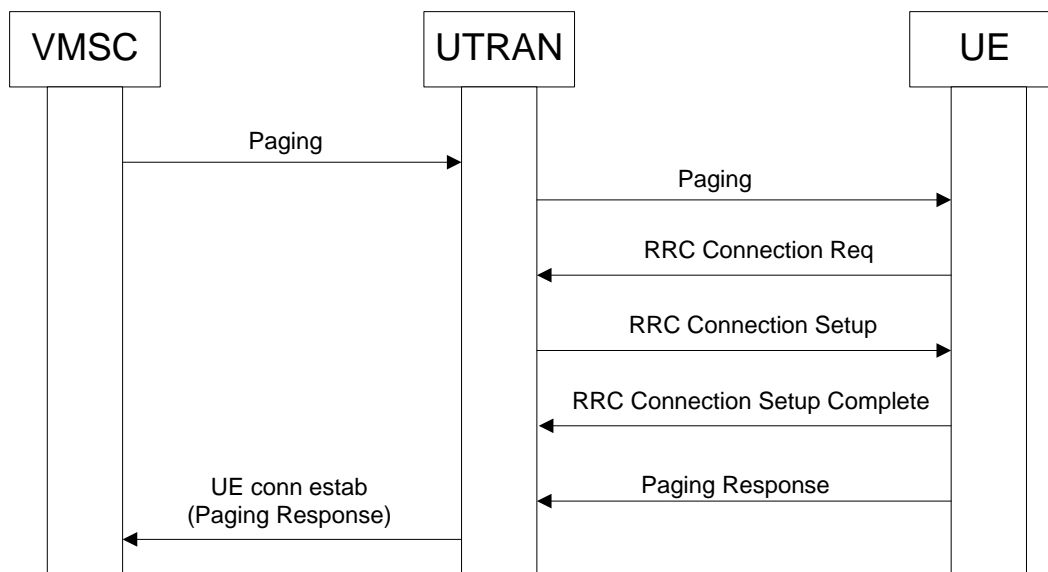

**Figure 6: information flow of paging**

### 4.1.7.1 Attempt paging requests per Lac

- a) This measurement provides the attempt number of paging requests per lac. The three measurement types defined in e) are subject to the "2 out of 3 approach".
- b) CC.
- c) On the transmission by MSC-S of the first paging request from the MSC-S to the RNC/BSC (3GPP TS 25.413 [5]).
- d) A single integer value per measurement type defined in e).
- e) CC.AttPageReqs Combined(don't care).  
 CC.AttPageReqs.G GSM.  
 CC.AttPageReqs.U UMTS.
- f) LA, specified by a concatenation of the MCC, MNC and LAC.
- g) Valid for circuit switched traffic.
- h) GSM/UMTS.

#### 4.1.7.2 Successful paging requests per Lac

- a) This measurement provides the successful number of paging requests per lac. The three measurement types defined in e) are subject to the "2 out of 3 approach".
- b) CC.
- c) On receipt by MSC-S of the Paging Response from the UE to the MSC-S (3GPP TS 24.008).
- d) A single integer value per measurement type defined in e).
- e) 

CC.SuccPageReqs	Combined(don't care).
CC.SuccPageReqs.G	GSM.
CC.SuccPageReqs.U	USMS.
- f) LA, specified by a concatenation of the MCC, MNC and LAC.
- g) Valid for circuit switched traffic.
- h) GSM/UMTS.

### 4.1.8 Out of band Call codec negotiation related performance

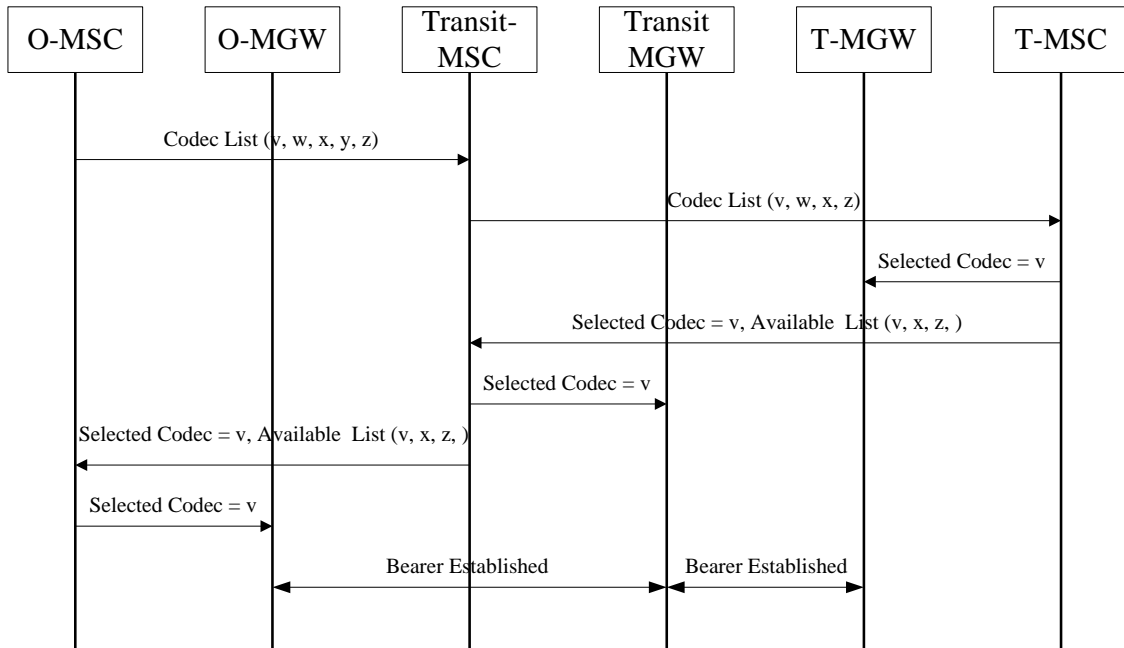

**Figure 7: information flow of codec negotiation**

NOTE: If the originating MSC-S uses G.711 codec, these measurements are not applicable.

#### 4.1.8.1 Attempted out of band codec negotiation number

- a) This measurement provides the number of codes negotiation attempts originated from MSC-S. If the originating MSC-S adopts G.711 codec, this negotiation establishment is not in the scope of R4 codec negotiation.
- b) CC.
- c) On transmission by the originating MSC-S of "IAM" message which includes codec list IE from the originating MSC-S to the terminated MSC-S. See 3GPP TS 23.153 [4].
- d) A single integer value.
- e) CC.AttCodecNeg.
- f) MSCServerFunction/VlrFunction.
- g) Valid for circuit switching.
- h) GSM/UMTS.



#### 4.1.8.2 Successful out of band codec negotiation number

- a) This measurement provides the number of successfully codes negotiation originated from MSC-S. If the originating MSC-S adopts G.711, and the originating mid-call receipt of "APM" message and "Selected Codec" is equal to "G.711", then this negotiation establishment is not in the scope of the R4 codec negotiation.
- b) CC.
- c) On receipt by originating MSC-S of "APM" message which "Action indicator=Selected Codec" from the terminated MSC-S See 3GPP TS 23.153 [4].
- d) A single integer value.
- e) CC.SuccCodecNeg.
- f) MSCServerFunction/VlrFunction.
- g) Valid for circuit switching.
- h) GSM/UMTS.

#### 4.1.8.3 Attempted out of band codec modification number

- a) This measurement provides the number of attempted TrFo codec modification request originated from MSC-S. The counter includes also the codec modifications executed as part of mid-call codec negotiation procedures.
- b) CC.
- c) On transmission by the MSC-S of an "APM" message and the action indicator is set to "modify codec" or "*modify to selected codec information*" (3GPP TS 24.011 and ITU-T Recommendation Q 1902.4).
- d) A single integer value.
- e) CC.AttCodecMod.
- f) MSCServerFunction/VlrFunction.
- g) Valid for circuit switching.
- h) GSM/UMTS.

#### 4.1.8.4 Successful out of band codec modification number

- a) This measurement provides the number of successful mid-call codec negotiations including the cases when the successful codec modifications executed as part of mid-call codec negotiation procedures.
- b) CC.
- c) On receipt by the MSC-S of an "APM" message and the received action indicator is set to "successful codec modification" (3GPP TS 24.011 and ITU-T Recommendation Q 1902.4).
- d) A single integer value.
- e) CC.SuccCodecMod.
- f) MSCServerFunction/VlrFunction.
- g) Valid for circuit switched traffic.
- h) GSM/UMTS.

#### 4.1.8.5 Failed out of band codec modification number

- a) This measurement provides the number of failed TrFo codec modification request originated from MSC-S including the cases when the failed codec modifications executed as part of the mid-call codec negotiation procedures.
- b) CC.
- c) On receipt by the MSC-S of an "APM" message and the received action indicator is set to "Codec Modification Failure" or "*mid-call codec negotiation failure*" (3GPP TS 24.011 and ITU-T Recommendation Q 1902.4).
- d) A single integer value.
- e) CM.FailCodecMod.
- f) MSCServerFunction/VlrFunction.
- g) Valid for circuit switching.
- h) GSM/UMTS.

## 4.1.9 Measurements based on Observed Destination

Editor's note: Observed Destination need to add to CN NRM

### 4.1.9.1 Attempted calls for calling party number

- a) This measurement provides the number of attempted UE originating and trunk incoming calls for the given observed destination where the observed destination is the calling number.
- b) CC.
- c) On receipt by the MSC-S of an "IAM" message from a given adjacent MSC-S (ITU-T Recommendation Q.1902) or "SETUP" from UE. The observed destination number should be taken from the MAP-Process\_access\_request\_Ack message that is received from the VLR (the MSISDN number of the calling subscriber) (see 3GPP TS 23.018 [11]) or the calling party number IE from IAM. (ITU-T Recommendation Q.763).
- d) A single integer value.
- e) CC.AttInODCalls    Combined.
- f) ObservedDestination.
- g) Valid for circuit switched traffic.
- h) GSM/UMTS.

### 4.1.9.2 Successful calls for calling party number

- a) This measurement provides the number of successful UE originating and trunk incoming calls for the given observed destination where the observed destination is the calling number.
- b) CC.
- c) On transmission by the MSC-S of an "ACM" message with "called party's status indicator = subscriber free" or "CPG" message with "event information = ALERTING" to an adjacent MSC-S (ITU-T Recommendations Q.1902 and Q.763) or on transmission by the MSC-S of an "Alerting" message to the originating UE (3GPP TS 24.008) for the requested observed destination.
- d) A single integer value.
- e) CC.SuccInODCalls.
- f) ObservedDestination.
- g) Valid for circuit switched traffic.
- h) GSM/UMTS.

#### 4.1.9.3 Answered calls for calling party number

- a) This measurement provides the number of answered UE originating and trunk incoming calls for the given observed destination where the observed destination is the calling number.
- b) CC.
- c) On transmission by the MSC-S of an "ANM" or "CON" message to a given adjacent MSC-S (ITU-T Recommendation Q.1902) or on receipt by the MSC-S of a "CONNECT ACKNOWLEDGE" message from the originating UE for the requested observed destination (3GPP TS 24.008, ITU-T Recommendations Q.723 and Q.763).
- d) A single integer value.
- e) CC.AnswInODCalls                      Combined.
- f) ObservedDestination.
- g) Valid for circuit switched traffic.
- h) GSM/UMTS.

#### 4.1.9.4 Call Traffic of Observed Destination for calling party number

- a) This measurement provides the call traffic of a given Observed Destination, where the Observed Destination is a calling number.
- b) DER(n=1).
- c) This measurement is obtained by accumulating the time intervals for the given observed destination (calling number) between the call start (IAM / SETUP) and the call end (RELEASE COMPLETE) over a granularity period using DER. The accumulator shall be reinitialised at the beginning of each granularity period.
- d) A single integer value (unit second).
- e) CC.SuccInODCallTraf.
- f) ObservedDestination.
- g) Valid for circuit switched traffic.
- h) GSM/UMTS.

#### 4.1.9.5 Attempted calls for called party numbers

- a) This measurement provides the number of attempted UE terminating and trunk outgoing calls for a given observed destination where the observed destination is called party number.
- b) CC.
- c) On transmission by the MSC-S of a "SETUP" message to the called UE (TS 24.008) or an "IAM" message to an adjacent MSC-S (ITU-T Recommendation Q.1902). The observed destination, i.e. the called party number should be taken from the SETUP message (called party BCD number IE) or from the IAM message (called party number).
- d) A single integer value.
- e) CC.AttOutODCalls                      Combined.
- f) ObservedDestination.
- g) Valid for circuit switched traffic.
- h) GSM/UMTS.

#### 4.1.9.6 Successful calls for the called party numbers

- a) This measurement provides the number of successful UE terminating and trunk outgoing calls for a given observed destination where the observed destination is called party number.
- b) CC.
- c) On receipt by the MSC-S of an "ALERTING" message from the called mobile (3GPP TS 24.008) or an "ACM" with "Called party's status indicator = subscriber free" or an "CPG" with "Event Information = ALERTING" (ITU-T Recommendation Q.763) for the given observed destination.
- d) A single integer value.
- e) CC.SuccOutODCalls.
- f) ObservedDestination.
- g) Valid for circuit switched traffic.
- h) GSM/UMTS.

#### 4.1.9.7 Answered calls for the called party numbers

- a) This measurement provides the number of answered UE terminating or trunk outgoing calls for a given observed destination where the observed destination is the called party number.
- b) CC.
- c) On transmission by the MSC-S of a "CONNECTION ACKNOWLEDGE" message to the called mobile (3GPP TS 24.008) or on reception of an "ANM" or "CON" message from an adjacent MSC-S (ITU-T Recommendation Q.1902) for the given observed destination.
- d) A single integer value.
- e) CC.AnswOutODCalls                      Combined.
- f) ObservedDestination.
- g) Valid for circuit switched traffic.
- h) GSM/UMTS.

#### 4.1.9.8 Call Traffic of Observed Destination for called party number

- a) This measurement provides the call traffic of a given ObservedDestination where the observed destination is a called party number.
- b) DER(n=1).
- c) This measurement is obtained by accumulating the time intervals for the given observed destination (called number) between the call start (IAM / SETUP) and the call end (RELEASE COMPLETE) over a granularity period using DER. The accumulator shall be reinitialised at the beginning of each granularity period.
- d) A single integer value. (Unit: Seconds).
- e) CC.SuccInODCallTraf.
- f) ObservedDestination.
- g) Valid for circuit switched traffic.
- h) GSM/UMTS.

## 4.2 Mobility management

### 4.2.1 Overview

This clause defines measurements related to the location updating and handover.

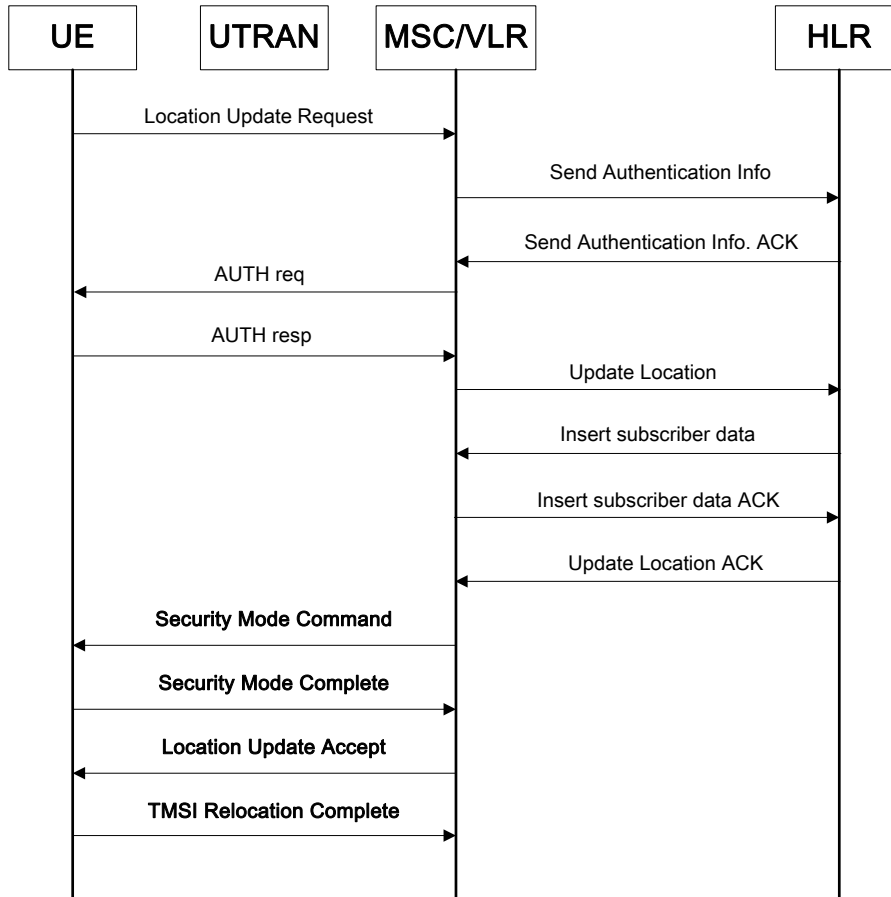

Figure 8: information flow related mobility

## 4.2.2 Location update

### 4.2.2.1 Attempted intra-VLR location update

- a) This measurement provides the number of attempted location updates to be performed by the MSC-S per location area (these are counted as attempts). (Location update type: Normal Intra-VLR location update). The three measurement types defined in e) are subject to the "2 out of 3 approach".
- b) CC.
- c) On receipt by VLR of "LOCATION UPDATING REQUEST" service request message from the UE by the VLR. The type of the location update is NORMAL (3GPP TS 24.008).
- d) A single integer value per measurement type defined in e).
- e) MM AttIntraVlrLU                      Combined(don't care).  
MM AttIntraVlrLU.G                      GSM.  
MM AttIntraVlrLU.U                      UMTS.
- f) LA, specified by a concatenation of the MCC, MNC and LAC.
- g) Valid for circuit switched traffic.
- h) GSM/UMTS.

### 4.2.2.2 Successful intra-VLR location update

- a) This measurement provides the number of successful location updates to be performed by the MSC-S per location area (these are counted as attempts). (Location update type: Normal Intra-VLR location update). The three measurement types defined in e) are subject to the "2 out of 3 approach".
- b) CC.
- c) On transmission of "LOCATION UPDATING ACCEPT" message by VLR to UE and this message doesn't include error information.(3GPP TS 24.008).
- d) A single integer value per measurement type defined in e).
- e) MM.SuccIntraVlrLU                      Combined(don't care).  
MM.SuccIntraVlrLU.G                      GSM.  
MM.SuccIntraVlrLU.U                      UMTS.
- f) LA, specified by a concatenation of the MCC, MNC and LAC.
- g) Valid for circuit switched traffic.
- h) GSM/UMTS.

#### 4.2.2.3 Attempted inter-VLR location update

- a) This measurement provides the number of attempted location updates to be performed by the MSC-S per location area (these are counted as attempts). (Location update type: Normal Inter-VLR location update). The three measurement types defined in e) are subject to the "2 out of 3 approach".
- b) CC.
- c) On receipt by VLR of "LOCATION UPDATING REQUEST" service request message from the UE by the VLR. The type of the location update is NORMAL and the LAC is in different VLR (3GPP TS 24.008).
- d) A single integer value per measurement type defined in e).
- e) 

MM.AttInterVlrLU	Combined(don't care).
MM.AttInterVlrLU.G	GSM.
MM.AttInterVlrLU.U	UMTS.
- f) LA, specified by a concatenation of the MCC, MNC and LAC.
- g) Valid for circuit switched traffic.
- h) GSM/UMTS.

#### 4.2.2.4 Successful inter-VLR location update

- a) This measurement provides the number of successful location updates to be performed by the MSC-S per location area (these are counted as attempts). (Location update type: Normal Inter-VLR location update). The three measurement types defined in e) are subject to the "2 out of 3 approach".
- b) CC.
- c) On transmission by VLR of "LOCATION UPDATING ACCEPT" message from VLR to UE and this message doesn't include error information.(3GPP TS 24.008).
- d) A single integer value per measurement type defined in e).
- e) 

MM.SuccInterVlrLU	Combined(don't care).
MM.SuccInterVlrLU.G	GSM.
MM.SuccInterVlrLU.U	UMTS.
- f) LA, specified by a concatenation of the MCC, MNC and LAC.
- g) Valid for circuit switched traffic.
- h) GSM/UMTS.



#### 4.2.2.5 Attempted location update for IMSI attach

- a) This measurement provides the number of attempted location updates to be performed by the MSC-S per location area (these are counted as attempts). (Location update type: IMSI attach). The three measurement types defined in e) are subject to the "2 out of 3 approach".
- b) CC.
- c) On receipt by VLR of "LOCATION UPDATING REQUEST" service request message from the UE to the VLR. The type of the location update is IMSI attached and Intra-VLR (3GPP TS 24.008).
- d) A single integer value per measurement type defined in e).
- e) MM.AttIntraVlrIMSILU                      Combined(don't care).  
MM.AttIntraVlrIMSILU.G                      GSM.  
MM.AttIntraVlrIMSILU.U                      UMTS.
- f) LA, specified by a concatenation of the MCC, MNC and LAC.
- g) Valid for circuit switched traffic.
- h) GSM/UMTS.

#### 4.2.2.6 Successful location update for IMSI attach

- a) This measurement provides the number of successful location updates to be performed by the MSC-S per location area (these are counted as successful). (Location update type: IMSI attach). The three measurement types defined in e) are subject to the "2 out of 3 approach".
- b) CC.
- c) On transmission by VLR of "LOCATION UPDATING ACCEPT" message from VLR to UE and this message doesn't include error information.(3GPP TS 24.008).
- d) A single integer value per measurement type defined in e).
- e) MM.SuccIntraVlrIMSILU                      Combined(don't care).  
MM.SuccIntraVlrIMSILU.G                      GSM.  
MM.SuccIntraVlrIMSILU.U                      UMTS.
- f) LA, specified by a concatenation of the MCC, MNC and LAC.
- g) Valid for circuit switched traffic.
- h) GSM/UMTS.

#### 4.2.2.7 Attempted period location update

- a) This measurement provides the number of attempted period location updates to be performed by the MSC-S per location area. (Location update type: period location update). The three measurement types defined in e) are subject to the "2 out of 3 approach".
- b) CC.
- c) On receipt by VLR of "LOCATION UPDATING REQUEST" service request message from the UE to the VLR. The type of the location update is PERIODIC (3GPP TS 24.008).
- d) A single integer value per measurement type defined in e).
- e) MM.AttPeriodLU                      Combined(don't care).  
MM.AttPeriodLU.G                      GSM.  
MM.AttPeriodLU.U                      UMTS.
- f) LA, specified by a concatenation of the MCC, MNC and LAC.
- g) Valid for circuit switched traffic.
- h) GSM/UMTS.

#### 4.2.2.8 Successful period location update

- a) This measurement provides the number of successful period location updates to be performed by the MSC-S per location area. (Location update type: period location update). The three measurement types defined in e) are subject to the "2 out of 3 approach".
- b) CC.
- c) On transmission by VLR of "LOCATION UPDATING ACCEPT" message from VLR to UE and this message doesn't include error information. (3GPP TS 24.008).
- d) A single integer value per measurement type defined in e).
- e) MM.SuccPeriodLU                      Combined(don't care).  
MM.SuccPeriodLU.G                      GSM.  
MM.SuccPeriodLU.U                      UMTS.
- f) LA, specified by a concatenation of the MCC, MNC and LAC.
- g) Valid for circuit switched traffic.
- h) GSM/UMTS.

### 4.2.3 Hand over inter MSC-S

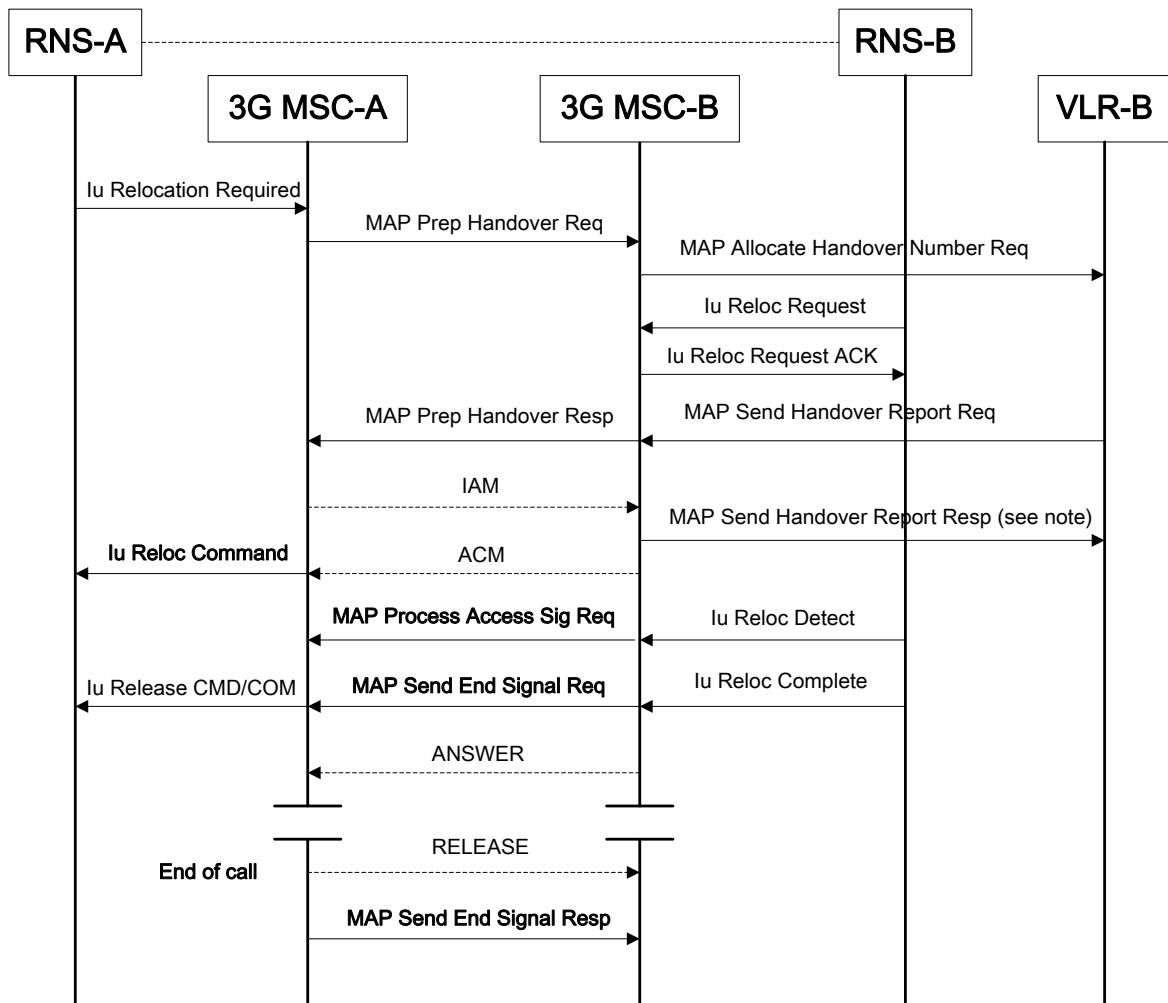

NOTE: Can be sent at any time after the reception of IAM.

Figure 9: Information flow of handover

#### 4.2.3.1 Attempted subsequent handover back to MSCa

- a) This measurement provides the number of attempted subsequent inter-MSCHandovers, where the call is handed back to the anchor MSC (MSCa), i.e. the first hand over takes place from MSCa to MSCb then subsequently an attempt is made to hand back to MSCa.
- b) CC.
- c) On receipt by MSCa of "MAP\_PERFORM\_SUBSEQUENT\_HANDOVER" service indication with target MSC identity equal to MSCa and current handover is in inter-MSCHandover status (3GPP TS 09.02 [17]).
- d) A single integer value.
- e) MM.AttSubsequentHosToMsca.
- f) MSCServerFunction/VlrFunction.
- g) Valid for circuit switched traffic.
- h) GSM/UMTS.

#### 4.2.3.2 Successful subsequent handover back to MSCa

- a) This measurement provides the number of successful subsequent inter-MSC Handovers, where the call is handed back to the anchor MSC (MSCa). i.e. the first hand over takes place from MSCa to MSCb then the call is subsequently successfully handed back to MSCa.
- b) CC.
- c) On transmission by MSCa of "MAP\_SEND\_END\_SIGNAL" service response (Handover to MSCa) and current handover is in inter-MSC handover status (3GPP TS 09.02 [17]).
- d) A single integer value.
- e) MM.SuccSubsequentHosToMsca.
- f) MSCServerFunction/VlrFunction.
- g) Valid for circuit switched traffic.
- h) GSM/UMTS.

#### 4.2.3.3 Attempted subsequent handover to MSCc

- a) This measurement provides the number of attempted subsequent inter-MSC Handovers, where the call is handed over to MSCc, i.e. the first hand over takes place from MSCa to MSCb then subsequently an attempt is made to hand over to MSCc.
- b) CC.
- c) On receipt of "MAP\_PERFORM\_SUBSEQUENT\_HANDOVER" service indication, with target MSC identity equal to MSCc and current handover is in inter-MSC handover status (3GPP TS 09.02 [17]).
- d) A single integer value.
- e) MM SuccSubsequentHosToMsc.
- f) MSCServerFunction/VlrFunction.
- g) Valid for circuit switched traffic.
- h) GSM/UMTS.

#### 4.2.3.4 Successful subsequent handover to MSCc

- a) This measurement provides the number of successful subsequent inter-MSC Handovers, where the call is handed over to MSCc, i.e. the first hand over takes place from MSCa to MSCb then the call is subsequently successfully handed over to MSCc.
- b) CC.
- c) On transmission of "MAP\_SEND\_END\_SIGNAL" service response (Handover to MSCc) and current handover is in inter-MSC handover status (3GPP TS 09.02 [17]).
- d) A single integer value.
- e) MM SuccSubsequentHosToMsc.
- f) MSCServerFunction/VlrFunction.
- g) Valid for circuit switched traffic.
- h) GSM/UMTS.

#### 4.2.3.5 Attempted incoming handovers inter MSC-S from UMTS to UMTS

- a) This measurement provides the number of attempted incoming Handovers into the observed UTRAN CELL from the related adjacent UTRAN CELLS NOT controlled by this MSC-S.
- b) CC.
- c) On receipt of a "MAP\_PERFORM\_HANDBOVER" service indication with target CELL identity equal to the observed CELL. Both the source cell and target cell are all UTRAN cell and current handover is in inter-MSC handover status (3GPP TS 09.02 [17]).
- d) A single integer value.
- e) MM.AttInc3GHo3GInterMsc.
- f) MSCServerFunction/VlrFunction.
- g) Valid for circuit switched traffic.
- h) UMTS.

#### 4.2.3.6 Successful incoming handovers inter MSC-S from UMTS to UMTS

- a) This measurement provides the number of attempted incoming Handovers into the observed UTRAN CELL from the related adjacent UTRAN CELLS NOT controlled by this MSC-S.
- b) CC.
- c) On receipt of a "MAP\_SEND\_END\_SIGNAL" service confirmation (3GPP TS 09.02 [17]). Both the source cell and target cell are all UTRAN cell and current handover is in inter-MSC handover status (3GPP TS 09.02 [17]).
- d) A single integer value.
- e) MM.SuccInc3GHo3GInterMsc.
- f) MSCServerFunction/VlrFunction.
- g) Valid for circuit switched traffic.
- h) UMTS.

#### 4.2.3.7 Attempted outgoing handovers inter MSC-S from UMTS to UMTS

- a) This measurement provides the number of attempted outgoing Handovers into the observed UTRAN CELL from the related adjacent UTRAN CELLS NOT controlled by this MSC-S.
- b) CC.
- c) On transmission of a "MAP\_PERFORM\_HANDBOVER" service request .Both the source cell and target cell are all UTRAN cell and current handover is in inter-MSC handover status (3GPP TS 09.02 [17]).
- d) A single integer value.
- e) MM.AttOut3GHo3GInterMsc.
- f) MSCServerFunction/VlrFunction.
- g) Valid for circuit switched traffic.
- h) UMTS.

#### 4.2.3.8 Successful outgoing handovers inter MSC-S from UMTS to UMTS

- a) This measurement provides the number of successful outgoing Handovers into the observed UTRAN CELL from the related adjacent UTRAN CELLS NOT controlled by this MSC-S.
- b) CC.
- c) On transmission of "MAP\_SEND\_END\_SIGNAL" service response . Both the source cell and target cell are all UTRAN cell and current handover is in inter-MSC handover status (3GPP TS 09.02 [17]).
- d) A single integer value.
- e) MM.SuccOut3GHo3GInterMsc.
- f) MSCServerFunction/VlrFunction.
- g) Valid for circuit switched traffic.
- h) UMTS.

#### 4.2.3.9 Attempted incoming handovers inter MSC-S from UMTS to GSM

- a) This measurement provides the number of attempted incoming Handovers into the observed GSM CELL from the related adjacent UTRAN CELLS NOT controlled by this MSC-S.
- b) CC.
- c) On receipt of a "MAP\_PERFORM\_HANOVER" service indication with target cell (target RNC) identity equal to observed cell. The source cell is UTRAN cell and target cell is GSM cell. Current handover is in inter-MSC handover status (3GPP TS 09.02 [17]).
- d) A single integer value.
- e) MM.AttInc3GHo2GInterMsc.
- f) MSCServerFunction/VlrFunction.
- g) Valid for circuit switched traffic.
- h) UMTS.

#### 4.2.3.10 Successful incoming handovers inter MSC-S from UMTS to GSM

- a) This measurement provides the number of successful incoming Handovers into the observed GSM CELL from the related adjacent UTRAN CELLS NOT controlled by this MSC-S.
- b) CC.
- c) On receipt of a "MAP\_SEND\_END\_SIGNAL" service confirmation (3GPP TS 09.02 [17]). The source cell is UTRAN cell and target cell is GSM cell. Current handover is in inter-MSC handover status (3GPP TS 09.02 [17]).
- d) A single integer value.
- e) MM.SuccInc3GHo2GInterMsc
- f) MSCServerFunction/VlrFunction.
- g) Valid for circuit switched traffic.
- h) UMTS.

#### 4.2.3.11 Attempted outgoing handovers inter MSC-S from UMTS to GSM

- a) This measurement provides the number of attempted outgoing Handovers into the observed GSM CELL from the related adjacent UTRAN CELLS NOT controlled by this MSC-S.
- b) CC.
- c) On transmission of a "MAP\_PERFORM\_HANDOVER" service request. The source cell is UTRAN cell and target cell is GSM cell. Current handover is in inter-MSC handover status (3GPP TS 09.02 [17]).
- d) A single integer value.
- e) MM.AttOut3GHo2GInterMsc.
- f) MSCServerFunction/VlrFunction.
- g) Valid for circuit switched traffic.
- h) UMTS.

#### 4.2.3.12 Successful outgoing handovers inter MSC-S from UMTS to GSM

- a) This measurement provides the number of successful outgoing Handovers into the observed GSM CELL from the related adjacent UTRAN CELLS NOT controlled by this MSC-S.
- b) CC.
- c) On transmission of "MAP\_SEND\_END\_SIGNAL" service response. The source cell is UTRAN cell and target cell is GSM cell. Current handover is in inter-MSC handover status (3GPP TS 09.02 [17]).
- d) A single integer value.
- e) MM.SuccOut3GHo2GInterMsc.
- f) MSCServerFunction/VlrFunction.
- g) Valid for circuit switched traffic.
- h) GSM/UMTS.

### 4.2.4 Handover Intra MSC-S

The measurements defined in 4.2.4.1-3 are subject to the "2 out of 3 approach".

#### 4.2.4.1 Attempted Handover Intra MSC-S from UMTS to GSM

- a) This measurement provides the number of attempted Handover Intra MSC-S from UMTS to GSM.
- b) CC.
- c) On receipt of an "IU\_RELOCATION\_REQUIRED" service indication. Both the source cell and the target cell are within one MSC Server (3GPP TS 23.009 [34]).
- d) An integer value.
- e) MM.Att3GHo2GIntraMsc.
- f) MSCServerFunction/VlrFunction.
- g) Valid for circuit switched traffic.
- h) GSM/UMTS.

#### 4.2.4.2 Successful Handover Intra MSC-S from UMTS to GSM

- a) This measurement provides the number of attempted Handover Intra MSC-S from UMTS to GSM.
- b) CC.
- c) On receipt of a "HANDOVER\_COMPLETE" service indication. Both the source cell and the target cell are within one MSC Server (3GPP TS 23.009 [34]).
- d) An integer value.
- e) MM.Succ3GHo2GIntraMsc.
- f) MSCServerFunction/VlrFunction.
- g) Valid for circuit switched traffic.
- h) GSM/UMTS.

#### 4.2.4.3 Failed Handover Intra MSC-S from UMTS to GSM

- a) This measurement provides the number of failed Handover Intra MSC-S from UMTS to GSM.
- b) CC.
- c) On sending of a "IU\_RELOCATION\_PREPARATION\_FAILURE" message to source RNS. Both the source cell and the target cell are within one MSC Server (3GPP TS 23.009 [34]).
- d) An integer value.
- e) MM.Failed3GHo2GIntraMsc.
- f) MSCServerFunction/VlrFunction.
- g) Valid for circuit switched traffic.
- h) GSM/UMTS.

The measurements defined in 4.2.4.4-6 are subject to the "2 out of 3 approach".

#### 4.2.4.4 Attempted Handover Intra MSC-S from GSM to UMTS

- a) This measurement provides the number of attempted Handover Intra MSC-S from GSM to UMTS.
- b) CC.
- c) On receipt of an "HANDOVER\_REQUIRED" service indication. Both the source cell and the target cell are within one MSC Server (3GPP TS 23.009 [34]).
- d) An integer value.
- e) MM.Att2GHo3GIntraMsc.
- f) MSCServerFunction/VlrFunction.
- g) Valid for circuit switched traffic.
- h) GSM/UMTS.

#### 4.2.4.5 Successful Handover Intra MSC-S from GSM to UMTS

- a) This measurement provides the number of attempted Handover Intra MSC-S from GSM to UMTS.
- b) CC.



- c) On receipt of an "IU\_RELOCATION\_COMPLETE" service indication. Both the source cell and the target cell are within one MSC Server (3GPP TS 23.009 [34]).
- d) An integer value.
- e) MM.Succ2GHo3GIntraMsc.
- f) MSCServerFunction/VlrFunction.
- g) Valid for circuit switched traffic.
- h) GSM/UMTS.

#### 4.2.4.6 Failed Handover Intra MSC-S from GSM to UMTS

- a) This measurement provides the number of failed Handover Intra MSC-S from GSM to UMTS.
- b) CC.
- c) On sending of a "HANDOVER\_FAILURE" message to source BSS. Both the source cell and the target cell are within one MSC Server (3GPP TS 23.009 [34]).
- d) An integer value.
- e) MM.Failed2GHo3GIntraMsc.
- f) MSCServerFunction/VlrFunction.
- g) Valid for circuit switched traffic.
- h) GSM/UMTS.

The measurements defined in 4.2.4.7-9 are subject to the "2 out of 3 approach".

#### 4.2.4.7 Attempted SRNS Relocation Intra MSC-S from UMTS to UMTS

- a) This measurement provides the number of attempted RNS relocation Intra MSC-S from UMTS to UMTS.
- b) CC.
- c) On receipt of a "IU\_RELOCATION\_REQUIRED" service indication. Both the source cell and the target cell are within one MSC Server (3GPP TS 23.009 [34]).
- d) An integer value.
- e) MM.Att3GHo3GIntraMsc.
- f) MSCServerFunction/VlrFunction.
- g) Valid for circuit switched traffic.
- h) GSM/UMTS.

#### 4.2.4.8 Successful SRNS Relocation Intra MSC-S from UMTS to UMTS

- a) This measurement provides the number of attempted SRNS relocation Intra MSC-S from UMTS to UMTS.
- b) CC.
- c) On receipt of a "RELOCATION\_COMPLETE" service indication. Both the source cell and the target cell are within one MSC Server (3GPP TS 23.009 [34]).
- d) An integer value.

- e) MM. Succ3GHo3GIntraMsc.
- f) MSCServerFunction/VlrFunction.
- g) Valid for circuit switched traffic.
- h) GSM/UMTS.

#### 4.2.4.9 Failed SRNS Relocation Intra MSC-S from UMTS to UMTS

- a) This measurement provides the number of failed SRNS relocation Intra MSC-S from UMTS to UMTS.
- b) CC.
- c) On sending of a "IU\_RELOCATION\_PREPARATION\_FAILURE" message to source RNS. Both the source cell and the target cell are within one MSC Server (3GPP TS 23.009 [34]).
- d) An integer value.
- e) MM. Failed3GHo3GIntraMsc.
- f) MSCServerFunction/VlrFunction.
- g) Valid for circuit switched traffic.
- h) GSM/UMTS.

## 4.3 Signalling

### 4.3.1 Overview

This clause defines the signalling related performance measurements related to M3UA and MTP3.

### 4.3.2 M3UA link related measurements

#### 4.3.2.1 Number of received messages on M3UA link

- a) This measurement provides the number of messages received on each M3UA link.
- b) CC.
- c) Incremented when M3UA messages are received on the M3UA link.
- d) A single integer value.
- e) SIG.M3UALKPkReceived.
- f) M3UALinkTP.
- g) Valid for circuit switched traffic.
- h) GSM/UMTS.

#### 4.3.2.2 Number of sent messages on M3UA link

- a) This measurement provides the number of messages sent on each M3UA link.
- b) CC.
- c) Incremented when M3UA messages are sent on the M3UA link.
- d) A single integer value.
- e) SIG.M3UALKPkSent.
- f) M3UALinkTP.
- g) Valid for circuit switched traffic.
- h) GSM/UMTS.

#### 4.3.2.3 Number of octets received on M3UA link

- a) This measurement provides the number of M3UA message octets received on each M3UA link.
- b) CC.
- c) Incremented when M3UA messages are received on the M3UA link.
- d) A single integer value.
- e) SIG.M3UALKOctReceived.
- f) M3UALinkTP.
- g) Valid for circuit switched traffic.
- h) GSM/UMTS.

#### 4.3.2.4 Number of octets sent on M3UA link

- a) This measurement provides the number of M3UA message octets sent on each M3UA link.
- b) CC.
- c) Incremented when M3UA messages are sent on the M3UA link.
- d) A single integer value.
- e) SIG.M3UALKOctSent.
- f) M3UALinkTP.
- g) Valid for circuit switched traffic.
- h) GSM/UMTS.

#### 4.3.2.5 Mean duration of M3UA link congestion

- a) This measurement provides the mean congestion duration of M3UA link.

NOTE: M3UA link is based on SCTP association, The M3UA congestion happens when it can not send messages to SCTP layer.. Concept of M3UA link refers to CN CS NRM modelling method.

- b) DER(n=1).
- c) The congestion duration of M3UA links in a measurement period.
- d) A real value (Unit: second).
- e) SIG.M3UALKCongestionDurationMean.
- f) M3UALinkTP.
- g) Valid for circuit switched traffic.
- h) GSM/UMTS.

#### 4.3.2.6 Number of M3UA link congestion times

- a) This measurement provides the number of M3UA link congestion times.
- b) CC.
- c) The number of congestion times of M3UA link in a measurement period.
- d) A single integer value.
- e) SIG.NbrM3UALKCongestion.
- f) M3UALinkTP.
- g) Valid for circuit switched traffic.
- h) GSM/UMTS.

#### 4.3.2.7 Mean unavailable time of M3UA link

- a) This measurement provides the unavailable duration of M3UA link.
- b) DER (n=1).
- c) Measurement is started when the M3UA link becomes unavailable and stopped when available.
- d) A real value. (unit: second)
- e) SIG.M3UALKUnavailableDurationMean.
- f) M3ULinkTP.
- g) Valid for circuit switched traffic.
- h) GSM/UMTS.

#### 4.3.2.8 Number of M3UA link unavailable times

- a) This measurement provides the number of unavailable times of M3UA link..
- b) CC.
- c) The number of out-of-service times of M3UA link in a measurement period.
- d) A single integer value.
- e) SIG.NbrM3UALKUnavailable.
- f) M3ULinkTP.
- g) Valid for circuit switched traffic.
- h) GSM/UMTS.

### 4.3.3 MTP3 signalling link related measurements

#### 4.3.3.1 Mean duration of unavailable MTP3 signalling link

- a) This measurement provides the duration of MTP3 link being unavailable.
- b) DER (n=1).
- c) This measurement is obtained by accumulating the time intervals for beginning of unavailable of MTP3/MTP3B signalling link to the end of unavailable of MTP3 signalling link over a granularity period using DER, see 3GPP TS 25.413 [5].
- d) A real value. (unit: second)
- e) SIG.MTP3LKUnavailableDuration.
- f) SignLinkTp.
- g) Valid for circuit switched traffic.
- h) GSM/UMTS.

#### 4.3.3.2 Number of MTP3 signalling link unavailable times

- a) This measurement provides the number of unavailable times of signal link.
- b) CC.
- c) This measurement is obtained by addition of MTP3 signalling link unavailable over a granularity period.
- d) A single integer value.
- e) SIG.NbrMTP3LKUnavailable.
- f) SignLinkTp.
- g) Valid for circuit switched traffic.
- h) GSM/UMTS.

#### 4.3.3.3 Number of MSUs received on MTP3 signalling link

- a) This measurement provides the number of message signal units received on MTP3 signalling link.
- b) CC.
- c) On receipt of a message signal unit (ITU-T Recommendation Q.752).
- d) A single integer value.
- e) SIG.NbrMTP3MSUReceived.
- f) SignLinkTp.
- g) Valid for circuit switched traffic.
- h) GSM/UMTS.

#### 4.3.3.4 Number of MSUs sent on MTP3 signalling link

- a) This measurement provides the number of message signal units sent on signalling link.
- b) CC.
- c) On transmission of a message signal unit (ITU-T Recommendation Q.752).
- d) A single integer value.
- e) SIG.NbrMTP3MSUSent.
- f) SignLinkTp.
- g) Valid for circuit switched traffic.
- h) GSM/UMTS.

#### 4.3.3.5 Number of octets received on MTP3 signalling link

- a) This measurement provides the number of SIF and SIO octets received on signalling link.
- b) CC.
- c) On receipt of message signal unit (ITU-T Recommendation Q.752).
- d) A single integer value.
- e) SIG.MTP3OctReceived.
- f) SignLinkTp.
- g) Valid for circuit switched traffic.
- h) GSM/UMTS.

#### 4.3.3.6 Number of octets sent on MTP3 signalling link

- a) This measurement provides the number of SIF and SIO octets sent on signalling link.
- b) CC.
- c) On transmission of a message signal unit (ITU-T Recommendation Q.752).
- d) A single integer value.
- e) SIG.MTP3OctSent.
- f) SignLinkTp.
- g) Valid for circuit switched traffic.
- h) GSM/UMTS.

#### 4.3.3.7 Number of available MTP3 signalling link

- a) This measurement provides the number of available MTP3/MTP3B signalling link.
- NOTE: Available links include those in usage.
- b) GAUGE.
  - c) Void
  - d) A single integer value.
  - e) SIG.NbrMTP3LKAavailable.
  - f) SignLinkSetTp.
  - g) Valid for circuit switched traffic.
  - h) GSM/UMTS.

## 4.4 Equipment resource

### 4.4.1 Overview

This clause define performance measurements related to network element's parameters regarding to the resource usage status, system processing capability and system load, etc.

### 4.4.2 CPU Load

#### 4.4.2.1 Mean CPU Usage

- a) This measurement provides the average CPU load during the measurement period.
- b) SI.
- c) This measurement is obtained by sampling at a pre-defined interval, CPU load and then taking the arithmetic mean.

For the product with centralized controlled CPUs, there should be one CPU load. There is only one sub-counter for this measurement. Its name should be .sum.

For the product with distributed controlled CPUs, there should be CPU load for each CPU. Processor ID could be used to differentiate those CPUs.

- d) A real value (Unit: 100 %).
- e) EQPT.CPUUsageMean.  
EQPT.CPUUsage.CPUid                    load of each processor for distributed controlled mode.
- f) MSCServerFunction/VlrFunction.
- g) Valid for circuit switched traffic.
- h) GSM/UMTS.

### 4.4.3 Number of subscribers in VLR

#### 4.4.3.1 Number of registered subscribers in VLR

- a) This measurement provides the number of subscribers registered in the VLR per LAC.
- b) GAUGE.
- c) This measurement is obtained by sampling at a pre-defined interval the number of registered subscribers registered in the VLR.
- d) A single integer value.
- e) EQPT.NbrCurrentSubsInVlr.  
LA, specified by a concatenation of the MCC, MNC and LAC.
- f) MSCServerFunction/VlrFunction.
- g) Valid for circuit switched traffic.
- h) GSM/UMTS.



#### 4.4.3.2 Number of attached subscribers in VLR

- a) This measurement provides the number of subscribers attached in VLR per LAC.
- b) GAUGE.
- c) This measurement is obtained by sampling at a pre-defined interval the number of attached subscribers registered in the VLR.
- d) A single integer value.
- e) EQPT.NbrAttachedSubsInVlr.
- f) MSCServerFunction/VlrFunction.  
LA, specified by a concatenation of the MCC, MNC and LAC.
- g) Valid for circuit switched traffic.
- h) GSM/UMTS.

#### 4.4.3.3 Number of registered national roaming subscribers in VLR

- a) This measurement provides the number of registered national roaming subscriber per LAC.
- b) GAUGE.
- c) This measurement is obtained by sampling at a pre-defined interval the number of registered national roaming subscribers registered in the VLR. National roaming subscribers are those subscribers who are roaming in a VPLMN network and the network has the same MCC (and in some case the MNC also same).
- d) A single integer value.
- e) EQPT.NbrNationalRoamingSubsInVlr.
- f) MSCServerFunction/VlrFunction.  
LA, specified by a concatenation of the MCC, MNC and LAC.
- g) Valid for circuit switched traffic.
- h) GSM/UMTS.

#### 4.4.3.4 Number of attached national roaming subscribers in VLR

- a) This measurement provides the number of attached national roaming subscribers per LAC.
- b) GAUGE.
- c) This measurement is obtained by sampling at a pre-defined interval the number of attached national roaming subscribers registered in the VLR. National roaming subscribers are those subscribers who are roaming in a VPLMN network and the network has the same MCC (and in some case the MNC also same).
- d) A single integer value.
- e) EQPT.NbrAttachedNRSubsInVlr.
- f) MSCServerFunction/VlrFunction.  
LA, specified by a concatenation of the MCC, MNC and LAC.
- g) Valid for circuit switched traffic.
- h) GSM/UMTS.

#### 4.4.3.5 Number of registered international roaming subscriber in VLR

- a) This measurement provides the number of registered international subscribers per LAC.
- b) GAUGE.
- c) This measurement is obtained by sampling at a pre-defined interval the number of registered international roaming subscribers registered in the VLR. International roaming subscribers are those subscribers who are roaming in a VPLMN network and the network has a different MCC with HPLMN.
- d) A single integer value.
- e) EQPT.NbrInternationalRoamingSubsInVlr.
- f) MSCServerFunction/VlrFunction.  
LA, specified by a concatenation of the MCC, MNC and LAC.
- g) Valid for circuit switched traffic.
- h) GSM/UMTS.

#### 4.4.3.6 Number of attached international roaming subscribers in VLR

- a) This measurement provides the number of attached international roaming subscribers per LAC.
- b) GAUGE.
- c) This measurement is obtained by sampling at a pre-defined interval the number of attached international roaming subscribers registered in the VLR. International roaming subscribers are those subscribers who are roaming in a VPLMN network and the network has the different MCC with HPLMN.
- d) A single integer value.
- e) EQPT.NbrAttachedInterNRSubsInVlr.
- f) MSCServerFunction/VlrFunction.  
LA, specified by a concatenation of the MCC, MNC and LAC
- g) Valid for circuit switched traffic.
- h) GSM/UMTS.

### 4.4.4 Octets in MAC layer in MSC-S physical port

#### 4.4.4.1 Number of octets sent on MAC layer in MSC-S physical port

- a) This measurement provides the number of octets sent on the FE MAC layer during the measurement period in MSC-S physical port. The measurement types defined in e) are subject to the "n-1 out of n approach".
- b) CC
- c) Transmission by the MSC-S of an octet on the FE MAC layer.
- d) A single integer value.
- e) EQPT.MACOctSent                      total of sent throughputs of all ports.  
EQPT.MACOctSent.Port                sent throughput of the port identified by Port.
- f) MSCServerFunction/VlrFunction.
- g) Valid for circuit switched traffic.

- h) GSM/UMTS.

#### 4.4.4.2 Number of octets received on MAC layer in MSC-S physical port

- a) This measurement provides the number of octets received on the FE MAC layer during the measurement period in MSC-S physical port. The measurement types defined in e) are subject to the "n-1 out of n approach".
- b) CC.
- c) Receipt by the MSC-S of an octet on the FE MAC layer.
- d) A single integer value.
- e) EQPT.MACOctRecieved                      total of received throughputs of all ports.  
EQPT.MACOctRecieved.Port                  received throughput of the port identified by Port.
- f) MSCServerFunction/VlrFunction.
- g) Valid for circuit switched traffic.
- h) GSM/UMTS.

#### 4.4.5 Trunk resource related measurements

##### 4.4.5.1 Number of available trunks

- a) This measurement provides the number of available trunk in the measurement period. This measurement is valid to Unidirectional out, uni-directional in and bi-directional trunk.
- b) GAUGE.
- c) Void.
- d) A single integer value.
- e) EQPT.NbrAvailTrunks.
- f) MSCServerFunction/VlrFunction.
- g) Valid for circuit switched traffic.
- h) GSM/UMTS.

##### 4.4.5.2 Number of available circuits in trunk group

- a) This measurement provides the available circuit number, including the seized circuit number. This measurement is valid to Unidirectional out, uni-directional in and bi-directional trunk.
- b) GAUGE.
- c) Void.
- d) A single integer value.
- e) EQPT.NbrAvailCircuit.
- f) CircuitEndPointSubgroup.
- g) Valid for circuit switched traffic.
- h) GSM/UMTS.

## 4.4.6 H.248 message related measurements on Mc interface

Editor's note: McLink need to be added to CN NRM.

### 4.4.6.1 Number of H.248 messages received on Mc interface

- a) This measurement provides the number of H.248 messages received on the Mc interface during the measurement period.
- b) CC.
- c) On receipt of a H.248 message on Mc interface.
- d) A single integer value.
- e) EQPT.NbrMcH248MsgReceived.
- f) McLink.
- g) Valid for circuit switched traffic.
- h) GSM/UMTS.

### 4.4.6.2 Number of H.248 messages sent on Mc interface

- a) This measurement provides the number of H.248 messages sent on the Mc interface during the measurement period.
- b) CC.
- c) On transmission of a message on Mc interface.
- d) A single integer value.
- e) EQPT.NbrMcH248MsgSent.
- f) McLink.
- g) Valid for circuit switched traffic.
- h) GSM/UMTS.

### 4.4.6.3 Number of H.248 message octets received on Mc interface

- a) This measurement provides the number of H.248 message octets received on Mc interface during the measurement period.
- b) CC.
- c) On receipt of H.248 messages on Mc interface.
- d) A single integer value.
- e) EQPT.McH248OctReceived.
- f) McLink.
- g) Valid for circuit switched traffic.
- h) GSM/UMTS.

#### 4.4.6.4 Number of H.248 message octets sent on Mc interface

- a) This measurement provides the number of H.248 message octets sent on Mc interface during the measurement period.
- b) CC.
- c) On transmission of H.248 messages on Mc interface.
- d) A single integer value.
- e) EQPT.McH248OctSent.
- f) McLink.
- g) Valid for circuit switched traffic.
- h) GSM/UMTS.

#### 4.4.7 BICC message on Nc interface related measurements

*Editor's note: NcLink need to be added to CN NRM.*

##### 4.4.7.1 Number of BICC messages received on Nc interface

- a) This measurement provides the number of BICC messages received on the Nc interface during the measurement period.
- b) CC.
- c) On receipt of BICC message on Nc interface.
- d) A single integer value.
- e) EQPT.NbrNcMsgReceived.
- f) NcLink.
- g) Valid for circuit switched traffic.
- h) GSM/UMTS.

##### 4.4.7.2 Number of BICC messages sent on Nc interface

- a) This measurement provides the number of BICC messages sent on the Nc interface during the measurement period.
- b) CC.
- c) On transmission of message on Nc interface.
- d) A single integer value.
- e) EQPT.NbrNcMsgSent.
- f) NcLink.
- g) Valid for circuit switched traffic.
- h) GSM/UMTS.

#### 4.4.7.3 Number of octets of BICC message received on Nc interface

- a) This measurement provides the number of octets of BICC message received on Nc interface during the measurement period.
- b) CC.
- c) The relevant measurement is incremented on receipt of an octet of BICC message on the Nc interface.
- d) A single integer value.
- e) EQPT.NcOctReceived.
- f) NcLink.
- g) Valid for circuit switched traffic.
- h) GSM/UMTS.

#### 4.4.7.4 Number of octets of BICC message sent on Nc interface

- a) This measurement provides the number of octets of BICC message sent on Nc interface during the measurement period.
- b) CC.
- c) The relevant measurement is incremented on transmission of an octet of BICC message on the Nc interface.
- d) A single integer value.
- e) EQPT.NcOctSent.
- f) NcLink.
- g) Valid for circuit switched traffic.
- h) GSM/UMTS.

---

## 5 Measurements related to the CS MGW

### 5.1 Measurements related to signalling

#### 5.1.1 Overview

The signalling measurements definition of MGW is same as those of MSC Server except the measurement object is MGW Function. The measurements defined here are related to the Mc, IuCS, Nb and A interface.

#### 5.1.2 M3UA link of MGW related performance

##### 5.1.2.1 Number of messages received on M3UA link

- a) This measurement provides the number of messages received on each M3UA link.
- b) CC.
- c) On receipt of a M3UA message.
- d) A single integer value.
- e) SIG.M3UALKPkReceived.
- f) M3UALinkTP.
- g) Valid for circuit switched traffic.
- h) GSM/UMTS.

##### 5.1.2.2 Number of messages sent on M3UA link

- a) This measurement provides the number of messages sent on each M3UA link.
- b) CC.
- c) On transmission of a M3UA message.
- d) A single integer value.
- e) SIG.M3UALKPkSent.
- f) M3UALinkTP
- g) Valid for circuit switched traffic.
- h) GSM/UMTS.

### 5.1.2.3 Number of octets received on M3UA link

- a) This measurement provides the number of octets received on each M3UA link.
- b) CC.
- c) On receipt of a M3UA message.
- d) A single integer value.
- e) SIG.M3UALKOctReceived.
- f) M3UALinkTP
- g) Valid for circuit switched traffic.
- h) GSM/UMTS.

### 5.1.2.4 Number of octets sent on M3UA link

- a) This measurement provides the number of octets sent on each M3UA link.
- b) CC.
- c) On transmission of a M3UA message.
- d) A single integer value.
- e) SIG.M3UALKOctSent.
- f) M3UALinkTP.
- g) Valid for circuit switched traffic.
- h) GSM/UMTS.

### 5.1.2.5 Mean duration of M3UA link congestion

- a) This measurement provides the mean congestion duration of M3UA link.

NOTE: M3UA link is based on SCTP association, The M3UA congestion happens when it can not send messages to SCTP layer. When congestion happens, upper layer protocol of SCTP cannot deliver a message. It may receive a SCTP\_SEND\_FAILED message as a notification [reference: draft-ietf-tsvwg-sctpsocket, clause 5.3.1.4] with a parameter of out-of-resource (reference: RFC 2960 [19]). Concept of M3UA link refers to CN CS NRM modelling method.

- b) DER (n=1).
- c) The congestion duration of M3UA links in a measurement period.
- d) A real value (Unit: second).
- e) SIG.M3UALKCongestionDurationMean.
- f) M3UALinkTP.
- g) Valid for circuit switched traffic.
- h) GSM/UMTS.



### 5.1.2.6 Number of M3UA link congestion times

- a) This measurement provides the number of M3UA link congestion times.
- b) CC.
- c) The number of congestion times of M3UA link in a pre-defined interval.
- d) A single integer value.
- e) SIG.NbrM3UALKCongestion.
- f) M3UALinkTP.
- g) Valid for circuit switched traffic.
- h) GSM/UMTS.

### 5.1.2.7 Mean unavailable duration of M3UA link

- a) This measurement provides the unavailable duration of M3UA link.
- b) DER(n=1).
- c) This measurement is obtained by accumulating the time intervals for beginning of unavailable of M3UA link to the end of available of M3UA link over a granularity period using DER.
- d) A real value (unit: seconds).
- e) SIG.M3UALKUnavailableDurationMean.
- f) M3UALinkTP.
- g) Valid for circuit switched traffic.
- h) GSM/UMTS.

### 5.1.2.8 Number of M3UA link unavailable times

- a) This measurement provides the number of unavailable times of M3UA link.
- b) CC.
- c) This measurement is obtained by addition of M3UA signalling link unavailable occurrences over a granularity period.
- d) A single integer value.
- e) SIG.NbrM3UALKUnavailable.
- f) M3UALinkTP.
- g) Valid for circuit switched traffic.
- h) GSM/UMTS.

### 5.1.3 MTP3/MTP3B signalling link of MGW related performance

NOTE: The measurements included here for Level 3 are likely to be appropriate also in the broadband environment (ITU-T Recommendation Q.752).

#### 5.1.3.1 Number of MSUs received on MTP3/MTP3B signalling link

- a) This measurement provides the number of message signalling units received on signalling link (MSUs/SL, ITU-T Recommendation Q.752).
- b) CC.
- c) On receipt of a message signalling unit (ITU-T Recommendation Q.752).
- d) A single integer value.
- e) SIG.NbrMTP3MSUReceived (SIG.NbrMTP3BMSUReceived).
- f) SignLinkTp.
- g) Valid for circuit switched traffic.
- h) GSM/UMTS.

#### 5.1.3.2 Number of MSUs sent on MTP3/MTP3B signalling link

- a) This measurement provides the number of message signalling units sent on signalling link (MSUs/SL, ITU-T Recommendation Q.752).
- b) CC.
- c) On transmission of a message signalling unit (ITU-T Recommendation Q.752).
- d) A single integer value.
- e) SIG.NbrMTP3MSUSent(SIG.NbrMTP3BMSUSent).
- f) SignLinkTp.
- g) Valid for circuit switched traffic.
- h) GSM/UMTS.

#### 5.1.3.3 Number of octets received on MTP3/MTP3B signalling link

- a) This measurement provides the number of SIF and SIO octets received on signalling link (Octets/SL, ITU-T Recommendation Q.752).
- b) CC.
- c) On receipt of a message signalling unit (ITU-T Recommendation Q.752).
- d) A single integer value.
- e) SIG.MTP3OctReceived(SIG.MTP3BOctReceived).
- f) SignLinkTp.
- g) Valid for circuit switched traffic.
- h) GSM/UMTS.

#### 5.1.3.4 Number of octets sent on MTP3/MTP3B signalling link

- a) This measurement provides the number of SIF and SIO octets sent on signalling link (Octets/SL, ITU-T Recommendation Q.752).
- b) CC.
- c) On transmission of a message signalling unit (ITU-T Recommendation Q.752)
- d) A single integer value.
- e) SIG.MTP3OctSent(SIG.MTP3BOctSent).
- f) SignLinkTp.
- g) Valid for circuit switched traffic.
- h) GSM/UMTS.

#### 5.1.3.5 Number of available MTP3/MTP3B signalling link

- a) This measurement provides the number of available MTP3/MTP3B signalling link.
- NOTE: Available links include those in usage.
- b) GAUGE.
  - c) Void.
  - d) a single integer value.
  - e) SIG.NbrMTP3LKAavailable(SIG.NbrMTP3BLKAavailable).
  - f) MGW Function.
  - g) Valid for circuit switched traffic.
  - h) GSM/UMTS.

#### 5.1.3.6 Number of unavailable times of MTP3/MTP3B signalling link

- a) This measurement provides the number of unavailable time of MTP3/MTP3B signalling link.
- b) CC.
- c) This measurement is obtained by addition of MTP3/MTP3B signalling link unavailable occurrences over a granularity period.
- d) a single integer value.
- e) SIG.NbrMTP3LKUnavailable(SIG.NbrMTP3BLKUnavailable).
- f) MGW Function.
- g) Valid for circuit switched traffic.
- h) GSM/UMTS.

### 5.1.3.7 Mean duration of unavailable MTP3/MTP3B signalling link

- a) This measurement provides the mean duration of unavailable of MTP3/MTP3B signalling link.
- b) DER(n=1).
- c) This measurement is obtained by accumulating the time intervals for beginning of unavailable of MTP3/MTP3B signalling link to the end of unavailable of MTP3/MTP3B signalling link over a granularity period using DER, see 3GPP TS 25.413 [5].
- d) a realvalue.(Unit: second).
- e) SIG.MTP3LKUnavailableDurationMean(SIG.MTP3BLKUnavailableDurationMean).
- f) SignLinkTp.
- g) Valid for circuit switched traffic.
- h) GSM/UMTS.

## 5.1.4 Route set related performance

### 5.1.4.1 Number of occurrences of unavailability of a route set to a given destination

- a) This measurement provides the number of occurrences of unavailability of a routeset to a given destination (ITU-T Recommendation Q.752).
- b) CC
- c) Steps when all routes in the route set become unavailable.
- d) A single integer value.
- e) SIG.NbrRoutesetUnavailable.
- f) SignRouteSetNePart.
- g) Valid for circuit switched traffic.
- h) GSM/UMTS.

### 5.1.4.2 Duration of unavailability of a route set to a given destination

- a) This measurement provides the duration of unavailability of a routeset to a given destination in seconds (ITU-T Recommendation Q.752).
- b) DER (n=1).
- c) The unavailable duration of the route set in a measurement period.
- d) A single real value (unit: second).
- e) SIG.DurationRoutesetUnavailable.
- f) SignRouteSetNePart.
- g) Valid for circuit switched traffic.
- h) GSM/UMTS.

NOTE: The measurement object class could be extended beyond SignRouteSetNePart (which is currently defined in 3GPP TS 32.742 [20] - Signalling Transport NRM).

## 5.2 Measurements related to bearer control

### 5.2.1 Overview

The control plane signalling and the user plane bear are separated in R4. The bearer control of user plane is handled in this clause, including bearer setup and user plane initialized, etc.

### 5.2.2 Measurements related to the ATM AAL2 connection setup

#### 5.2.2.1 Attempted AAL2 connection setup

- a) This measurement provides the number of attempted connection setup on the Iu interface from RNC to MGW.
- b) CC.
- c) On receipt of a "ALCAP-ERQ"[1] message by MGW from RNC on the Iu interface.
- d) A single integer value.
- e) BC.AttAAL2ConnSetup.
- f) MGW Function.
- g) Valid for circuit switched traffic.
- h) UMTS.

#### 5.2.2.2 Successful AAL2 connection setup

- a) This measurement provides the successful AAL2 connection setup on the Iu interface from MGW to RNC.
- b) CC.
- c) On transmission by MGW of a "ALCAP-ECF"[1] message to RNC on the Iu interface.
- d) A single integer value.
- e) BC.SuccAAL2ConnSetup.
- f) MGW Function.
- g) Valid for circuit switched traffic.
- h) UMTS.

## 5.2.3 Measurements related to IP RTP connection

### 5.2.3.1 Attempted outgoing connection setup

- a) This measurement provides the attempted outgoing connection setup on the Nb interface.
- b) CC.
- c) On transmission by the MGW of an "IPBCP-Request" message for MGW on the Nb interface.
- d) A single integer value.
- e) BC.AttOutIpSetup.
- f) MGW Function.
- g) Valid for circuit switched traffic.
- h) GSM/UMTS.

### 5.2.3.2 Successful outgoing connection setup

- a) This measurement provides the successful outgoing connection setup on the Nb interface.
- b) CC.
- c) On receipt by MGW of "IPBCP-Accepted" message on the Nb interface.
- d) A single integer value.
- e) BC.SuccOutIpSetup.
- f) MGW Function.
- g) Valid for circuit switched traffic.
- h) GSM/UMTS.

### 5.2.3.3 Attempted incoming connection setup

- a) This measurement provides the attempted incoming connection setup on the Nb interface.
- b) CC.
- c) On receipt by MGW of an "IPBCP-Request" message on the Nb interface.
- d) A single integer value.
- e) BC.AttIncIpSetup.
- f) MGW Function.
- g) Valid for circuit switched traffic.
- h) GSM/UMTS.

#### 5.2.3.4 Successful incoming connection setup

- a) This measurement provides the successful incoming connection setup on the Nb interface.
- b) CC.
- c) On transmission by MGW of an "IPBCP-Accepted" message on Nb interface.
- d) A single integer value.
- e) BC.SuccIncIpsetup.
- f) MGW Function.
- g) Valid for circuit switched traffic.
- h) GSM/UMTS.

#### 5.2.4 Measurements related to the User Plane (UP) Init

##### 5.2.4.1 Attempted outgoing initial UP on the Nb interface

- a) This measurement provides the outgoing attempted initialization of UP on Nb interface.
- b) CC.
- c) On transmission by the MGW of a "UP-INITIALISATION" message for MGW on the Nb interface.
- d) A single integer value.
- e) BC.AttOutNbUPInit.
- f) MGW Function.
- g) Valid for circuit switched traffic.
- h) GSM/UMTS.

##### 5.2.4.2 Successful outgoing initial UP on the Nb interface

- a) This measurement provides the successful outgoing initialization of UP on the Nb interface.
- b) CC.
- c) On receipt by MGW of a "UP-INITIALISATION ACK" message on the Nb interface.
- d) A single integer value.
- e) BC.SuccOutNbUPInit.
- f) MGW Function.
- g) Valid for circuit switched traffic.
- h) GSM/UMTS.

#### 5.2.4.3 Attempted incoming initial UP on the Nb interface

- a) This measurement provides the attempted incoming initialization of UP on the Nb interface.
- b) CC.
- c) On receipt by MGW of a "UP-INITIALISATION" message on the Nb interface.
- d) A single integer value.
- e) BC.AttIncNbUPInit.
- f) MGW Function.
- g) Valid for circuit switched traffic.
- h) GSM/UMTS.

#### 5.2.4.4 Successful incoming initial UP on the Nb interface

- a) This measurement provides the successful incoming initialization of UP on the Nb interface.
- b) CC.
- c) On transmission by MGW of a "UP-INITIALISATION ACK" message on the Nb interface.
- d) A single integer value.
- e) BC.SuccIncNbUPInit.
- f) MGW Function.
- g) Valid for circuit switched traffic.
- h) GSM/UMTS.

#### 5.2.4.5 Attempted outgoing initial UP on the Iu interface

- a) This measurement provides the attempted outgoing initialization of UP on the Iu interface.
- b) CC.
- c) On transmission by MGW of a "UP-INITIALISATION" message on the Iu interface.
- d) A single integer value.
- e) BC.AttOutIuUPInit.
- f) MGW Function.
- g) Valid for circuit switched traffic.
- h) GSM/UMTS.



#### 5.2.4.6 Successful outgoing initial UP on the Iu interface

- a) This measurement provides the successful outgoing initialization of UP on the Iu interface.
- b) CC.
- c) On receipt by MGW of a "UP-INITIALISATION ACK" message on the Iu interface.
- d) A single integer value.
- e) BC.SuccOutIuUPInit.
- f) MGW Function.
- g) Valid for circuit switched traffic.
- h) GSM/UMTS.

#### 5.2.4.7 Attempted incoming initial UP on the Iu interface

- a) This measurement provides the attempted incoming initialization of UP on the Iu interface.
- b) CC.
- c) On receipt by MGW of a "UP-INITIALISATION" message on the Iu interface.
- d) A single integer value.
- e) BC.AttIncIuUPInit.
- f) MGW Function.
- g) Valid for circuit switched traffic.
- h) GSM/UMTS.

#### 5.2.4.8 Successful incoming initial UP on the Iu interface

- a) This measurement provides the successful incoming initialization of UP on the Iu interface.
- b) CC.
- c) On transmission by MGW of a "UP-INITIALISATION ACK" message on the Iu interface.
- d) A single integer value.
- e) BC.SuccIuUPInit.
- f) MGW Function.
- g) Valid for circuit switched traffic.
- h) GSM/UMTS.

## 5.3 Bearer transport

### 5.3.1 Overview

The clause defines performance measurements related to bearer transport layer in Nb interface.

### 5.3.2 Measurements related to Nb interface

#### 5.3.2.1 Number of RTP messages received on Nb interface

- a) This measurement provides the number of RTP message received on Nb interface.
- b) CC.
- c) On receipt by MGW of a RTP message on Nb interface.
- d) A single integer value.
- e) BRT.NbrNbRTPReceived.
- f) NbLink.
- g) Valid for circuit switched traffic.
- h) GSM/UMTS.

#### 5.3.2.2 Number of RTP messages sent on Nb interface

- a) This measurement provides the number of RTP messages sent on Nb interface.
- b) CC.
- c) On transmission by MGW of a RTP message on Nb interface.
- d) A single integer value.
- e) BRT.NbrNbRTPSent.
- f) NbLink.
- g) Valid for circuit switched traffic.
- h) GSM/UMTS.

#### 5.3.2.3 Number of RTP octets received on Nb interface

- a) This measurement provides the number of RTP octets received on Nb interface.
- b) CC.
- c) On receipt by MGW of a RTP message on Nb interface.
- d) A single integer value.
- e) BRT.NbOctRTPReceived.
- f) NbLink.
- g) Valid for circuit switched traffic.
- h) GSM/UMTS.

#### 5.3.2.4 Number of RTP octets sent on Nb interface

- a) This measurement provides the number of RTP octets sent on Nb interface.
- b) CC.
- c) On transmission by MGW of a RTP message on Nb interface
- d) A single integer value.
- e) BRT.NbOctRTPSent.
- f) NbLink.
- g) Valid for circuit switched traffic.
- h) GSM/UMTS.

#### 5.3.2.5 Number of lost RTP messages on Nb interface

- a) This measurement provides the number of lost RTP messages on Nb interface.
- b) CC.
- c) When failed of transmission of RTP messages to destination MGW
- d) A single integer value.
- e) BRT.NbrNbRTPLost.
- f) NbLink.
- g) Valid for circuit switched traffic.
- h) GSM/UMTS.

#### 5.3.2.6 The maximum delay on Nb interface

- a) This measurement provides the maximum delay on Nb interface.
- b) Gauge.
- c) This measurement is obtained by Calculating RTP streams in all direction based on RTCP on Nb interface over a granularity period (such as 5 seconds). The high tide mark of this time will be stored in a gauge, the gauge shall be reinitialised at the beginning of each granularity period.

NOTE: RTCP is an optional protocol.

- d) A single integer value (Unit: ms).
- e) BRT.NbRTPDelayMax.
- f) NbLink.
- g) Valid for circuit switched traffic.
- h) GSM/UMTS.

### 5.3.2.7 The maximum delay jitter on Nb interface

- a) This measurement provides the maximum delay jitter on Nb interface.
- b) Gauge.
- c) This measurement is obtained by Calculating RTP streams jitter based on RTCP on Nb interface (RFC 1889 [21] or RFC 3550 [22]) over a granularity period (It is settable for RTCP packet transmission period, 5 seconds is the normal value. The high tide mark of this time will be stored in a gauge, the gauge shall be reinitialised at the beginning of each granularity period).

NOTE: RTCP is an optional protocol.

- d) A single integer value (unit: millisecond).
- e) BRT.NbDelayJitterMax.
- f) NbLink.
- g) Valid for circuit switched traffic.
- h) GSM/UMTS.

### 5.3.2.8 The mean delay on Nb interface

- a) This measurement provides the mean delay on Nb interface.
- b) DER (n=1).
- c) This measurement is obtained by Calculating RTP streams in all direction based on RTCP on Nb interface over a granularity period (such as 5 seconds) using DER.

NOTE: RTCP is an optional protocol.

- d) A single integer value (Unit: ms).
- e) BRT. NbRTPDelayMean.
- f) NbLink.
- g) Valid for circuit switched traffic.
- h) GSM/UMTS.
- i) This measurement is only applicable to the network where RTCP is supported.

### 5.3.2.9 The mean delay Jitter on Nb interface

- a) This measurement provides the mean jitter on Nb interface.
- b) DER (n=1).
- c) This measurement is obtained by Calculating RTP streams jitter based on RTCP on Nb interface (RFC 1889 [21] or RFC 3550 [22]) over a granularity period (It is settable for RTCP packet transmission period, 5 seconds is the normal value ) using DER.

NOTE: RTCP is an optional protocol.

- d) A single integer value.
- e) BRT.NbDelayJitterMean.
- f) NbLink.
- g) Valid for circuit switched traffic.

- h) GSM/UMTS.
- i) This measurement is only applicable to the network where RTCP is supported.

### 5.3.3 AAL2 related measurements on Iu CS interface

#### 5.3.3.1 Number of AAL2 packets received on IuCS interface

- a) This measurement provides the number of ATM AAL2 packets received on IuCS AAL2 connection.
- b) CC.
- c) On receipt by MGW of AAL2 packets on AAL2 connection on the IuCS interface.
- d) A single integer value.
- e) BRT.NbrIuCSAAL2PktReceived.
- f) IuCSLink.
- g) Valid for circuit switched traffic.
- h) UMTS.

#### 5.3.3.2 Number of AAL2 packets sent on IuCS interface

- a) This measurement provides the number of ATM AAL2 packets sent on IuCS AAL2 connection.
- b) CC.
- c) On transmission by MGW of AAL2 packets on AAL2 connection on the IuCS interface
- d) A single integer value.
- e) BRT.NbrIuCSAAL2PktSent.
- f) IuCSLink.
- g) Valid for circuit switched traffic.
- h) UMTS.

#### 5.3.3.3 Octets of AAL2 packets received on IuCS interface

- a) This measurement provides the number of AAL2 packet octets received on IuCS AAL2 connection.
- b) CC.
- c) On receipt by MGW of AAL2 packets on IuCS interface.
- d) A single integer value.
- e) BRT.IuCSAAL2OctReceived.
- f) IuCSLink.
- g) Valid for circuit switched traffic.
- h) UMTS.

#### 5.3.3.4 Octets of AAL2 packets sent on IuCS interface

- a) This measurement provides the number of AAL2 packet octets sent on IuCS AAL2 connection.
- b) CC.

- c) On transmission by MGW of AAL2 packets on IuCS interface.
- d) A single integer value.
- e) BRT.IuCSAAL2OctSent.
- f) IuCSLink.
- g) Valid for circuit switched traffic.
- h) UMTS.

## 5.3.4 RTP related measurements on Iu CS interface

### 5.3.4.1 Number of RTP messages received on Iu interface

- a) This measurement provides the total number of RTP messages received on all Iu interface in one MGW.
- b) CC.
- c) On receipt by MGW of a RTP message on Iu interface.
- d) A single integer value.
- e) BRT.NbrIuRTPpktReceived.
- f) MGWFunction.
- g) Valid for circuit switched traffic.
- h) UMTS.

#### 5.3.4.2 Number of RTP messages sent on Iu interface

- a) This measurement provides the number of RTP messages sent on Iu interface.
- b) CC.
- c) On transmission by MGW of a RTP message on Iu interface.
- d) A single integer value.
- e) BRT.NbrIuRTPPktsSent.
- f) MGW Function.
- g) Valid for circuit switched traffic.
- h) UMTS.

#### 5.3.4.3 Number of RTP octets received on Iu interface

- a) This measurement provides the number of octets received on Iu interface.
- b) CC.
- c) On receipt by MGW of a RTP message on Iu interface.
- d) A single integer value.
- e) BRT.IuOctRTPReceived.
- f) MGW Function.
- g) Valid for circuit switched traffic.
- h) UMTS.

#### 5.3.4.4 Number of RTP octets sent on Iu interface

- a) This measurement provides the number of RTP octets sent on Iu interface.
- b) CC.
- c) On transmission by MGW of a RTP message on Iu interface.
- d) A single integer value.
- e) BRT.IuOctRTPSent.
- f) MGW Function.
- g) Valid for circuit switched traffic.
- h) UMTS.

#### 5.3.4.5 Number of lost RTP packets on Iu interface

- a) This measurement provides the number of lost RTP messages on Iu interface.
- b) CC.
- c) On failed of transmission RTP messages to destination MGW .
- d) A single integer value.
- e) BRT.NbrIuRTPLostPkt.
- f) MGWFunction.
- g) Valid for circuit switched traffic.
- h) UMTS.

#### 5.3.4.6 The maximum delay on Iu interface

- a) This measurement provides the maximum delay on Iu interface.
- b) Gauge.
- c) This measurement is obtained by Calculating RTP streams in all direction based on RTCP on Iu interface over a granularity period (such as 5 seconds). The high tide mark of this time will be stored in a gauge, the gauge shall be reinitialised at the beginning of each granularity period.

NOTE: RTCP is an optional protocol.

- d) A single integer value (Unit: ms).
- e) BRT.IuRTPDelayMax.
- f) MGWFunction.
- g) Valid for circuit switched traffic.
- h) UMTS.

#### 5.3.4.7 The maximum delay jitter on Iu interface

- a) This measurement provides the maximum delay jitter on Iu interface.
- b) Gauge.
- c) This measurement is obtained by Calculating RTP streams jitter based on RTCP on Iu interface (RFC 1889 [21] or RFC 3550 [22]) over a granularity period (It is settable for RTCP packet transmission period, 5 seconds is the normal value. The high tide mark of this time will be stored in a gauge, the gauge shall be reinitialised at the beginning of each granularity period).

NOTE: RTCP is an optional protocol.

- d) A single integer value.
- e) BRT. IuDelayJitterMax.
- f) MGWFunction.
- g) Valid for circuit switched traffic.
- h) UMTS.



### 5.3.2.8 The mean delay on Nb interface

- a) This measurement provides the mean delay on Nb interface.
- b) DER (n=1).
- c) This measurement is obtained by Calculating RTP streams in all direction based on RTCP on Nb interface over a granularity period (such as 5 seconds) using DER.

NOTE: RTCP is an optional protocol.

- d) A single integer value (Unit: ms).
- e) BRT. NbRTPDelayMean.
- f) NbLink.
- g) Valid for circuit switched traffic.
- h) GSM/UMTS.
- i) This measurement is only applicable to the network where RTCP is supported.

### 5.3.2.9 The mean delay Jitter on Nb interface

- a) This measurement provides the mean jitter on Nb interface.
- b) DER (n=1).
- c) This measurement is obtained by Calculating RTP streams jitter based on RTCP on Nb interface (RFC 1889 [21] or RFC 3550 [22]) over a granularity period (It is settable for RTCP packet transmission period, 5 seconds is the normal value ) using DER.

NOTE: RTCP is an optional protocol.

- d) A single integer value.
- e) BRT.NbDelayJitterMean.
- f) NbLink.
- g) Valid for circuit switched traffic.
- h) GSM/UMTS.
- i) This measurement is only applicable to the network where RTCP is supported.

### 5.3.5 Number of seized PVC link on Iu CS interface

- a) This measurement provides the number of seized PVC links established on Iu CS interface (Except of the PVC link created manually).
- b) CC.
- c) The relevant measurement is incremented when a PVC link is seized.
- d) A single integer value.
- e) BRT.NbrIuCSPVC.
- f) IuCSLink.
- g) Valid for circuit switched traffic.
- h) UMTS.

## 5.4 Equipment resource

### 5.4.1 Overview

This clause define performance measurements related to network element's parameters regarding to the resource usage status, system processing capability and system load, etc.

### 5.4.2 CPU Load

#### 5.4.2.1 Mean CPU usage

- a) This measurement provides the average CPU load during the measurement period.
- b) SI.
- c) This measurement is obtained by sampling at a pre-defined interval, CPU load and then taking the arithmetic mean.

For the product with centralized controlled CPUs, there should be one CPU load. There is only one sub-counter for this measurement. Its name should be .sum.

For the product with distributed controlled CPUs, there should be CPU load for each CPU. Processor ID could be used to differentiate those CPUs.

- d) A real value (Unit: percentage).
- e) EQPT.CPUUsageMean.  
EQPT.CPUUsage.CPUid      load of each processor for distributed controlled mode.
- f) MGW Function.
- g) Valid for circuit switched traffic.
- h) GSM/UMTS.

## 5.4.3 Octets in MAC layer in MGW port

### 5.4.3.1 Number of octets sent on MAC layer in MGW port

- a) This measurement provides the number of octets sent on the FE MAC layer during the measurement period in MGW port. The measurement types defined in e) are subject to the "n-1 out of n approach".
- b) CC.
- c) The relevant measurement is incremented on transmission of an octet on MAC layer in MGW port.
- d) A single integer value per measurement type defined in e).
- e) EQPT.MACOctSent                      total of sent throughputs of all ports.  
EQPT.MACOctSent.Port                sent throughput of the port identified by Port.
- f) MGWFunction.
- g) Valid for circuit switched traffic.
- h) GSM/UMTS.

### 5.4.3.2 Number of octets received on MAC layer in MGW port

- a) This measurement provides the number of octets received on the FE MAC layer during the measurement period in MGW port. The measurement types defined in e) are subject to the "n-1 out of n approach".
- b) CC.
- c) The relevant measurement is incremented on receipt of an octet on MAC layer in MGW port.
- d) A single integer value per measurement type defined in e).
- e) EQPT.MACOctRecieved                total of received throughputs of all ports.  
EQPT.MACOctRecieved.Port          received throughput of the port identified by Port.
- f) MGWFunction.
- g) Valid for circuit switched traffic.
- h) GSM/UMTS.

## 5.4.4 H.248 message related measurements on Mc interface

Editor's note: McLink need to be added to CN NRM.

### 5.4.4.1 Number of H.248 message received on Mc interface

- a) This measurement provides the number of H.248 messages received on Mc interface from MGW's perspective.
- b) CC.
- c) On receipt of a H.248 message on Mc interface.
- d) A single integer value.
- e) EQPT.NbrMcMsgReceived.
- f) McLink.
- g) Valid for circuit switched traffic.
- h) GSM/UMTS.

### 5.4.4.2 Number of H.248 message sent on Mc interface

- a) This measurement provides the number of H.248 message sent on Mc interface from MGW's perspective.
- b) CC.
- c) On transmission of a H.248 message on Mc interface.
- d) A single integer value.
- e) EQPT.NbrMcMsgSent.
- f) McLink.
- g) Valid for circuit switched traffic.
- h) GSM/UMTS.

### 5.4.4.3 Number of H.248 message octets received on Mc interface

- a) This measurement provides the number of H.248 message octets received on Mc interface from MGW's perspective.
- b) CC.
- c) On receipt of a H.248 message.
- d) A single integer value.
- e) EQPT.NbrMcH248OctReceived.
- f) McLink.
- g) Valid for circuit switched traffic.
- h) GSM/UMTS.

#### 5.4.4.4 Number of H.248 message octets sent on Mc interface

- a) This measurement provides the number of H.248 message octets sent on Mc interface from MGW 's perspective.
- b) CC.
- c) On transmission of a H.248 message on Mc interface.
- d) A single integer value.
- e) EQPT.NbrMcH248OctSent.
- f) McLink.
- g) Valid for circuit switched traffic.
- h) GSM/UMTS.

#### 5.4.5 Transcode

##### 5.4.5.1 Number of failed calls caused by transcode resource

- a) This measurement provides the number of failed calls caused by shortage of Transcoder.
- b) CC.
- c) On transmission of "Add Response", "Modify Response", "Notify Request" message with the value equal to "UR' (Unavailable Resource).
- d) A single integer value.
- e) EQPT.NbrCallFailureOfTCShortage.
- f) MGW Function.
- g) Valid for circuit switched traffic.
- h) GSM/UMTS.

##### 5.4.5.2 Number of attempted seized transcoder

- a) This measurement provides the number of attempted seized transcoder resource.
- b) CC.
- c) The relevant measurement is incremented when attempted seize for transcoder resource.
- d) A single integer value.
- e) EQPT.AttTCSeizure.
- f) MGW Function.
- g) Valid for circuit switched traffic.
- h) GSM/UMTS.

## 5.5 User Plane services

### 5.5.1 Overview

This clause defines performance measurements related to network elements' usage of the following User Plane services, for which failure to seize can lead to call loss:

- CC, Continuity Check (CC) [ITU-T Q.724]
- DTMF, DTMF Sending and Detection [TS 23.014]
- GTT, Global Text Telephony [TS 22.226]
- MFH, Media Frame Handler [TS 25.415, 29.415]
- MPC, Multiparty Call [ITU-T I.254.1]
- SC, Speech Coder [TS 23.153, 26.071, 26.090]
- TS, Tone Sender or Line Test [ITU-T E.182]

### 5.5.2 Continuity Check (CC)

#### 5.5.2.1 Number of seizure attempts for CC

- a) This measurement provides the number of attempts to seize CC services.
- b) CC.
- c) On receipt of H.248 commands "Add Request" or "Modify Request" for Continuity Check (CC) service.
- d) A single integer value.
- e) EQPT.NbrSeizureAttCC
- f) MGW Function.
- g) Valid for circuit switched traffic.
- h) UMTS.

#### 5.5.2.2 Number of successful CC seizures

- a) This measurement provides the number of successful attempts to seize CC services.
- b) CC.
- c) On sending of H.248 commands "Add Reply" or "Modify Reply" after the "Add Request" or "Modify Request" for Continuity Check (CC) service has been successfully executed without any failure such as congestion.
- d) A single integer value.
- e) EQPT.NbrSeizureSuccCC
- f) MGW Function.
- g) Valid for circuit switched traffic.
- h) UMTS.

## 5.5.3 DTMF Sending and Detection (DTMF)

### 5.5.3.1 Number of seizure attempts for DTMF

- a) This measurement provides the number of attempts to seize DTMF services.
- b) CC.
- c) On receipt of H.248 commands "Add Request" or "Modify Request" for DTMF Sending and Detection (DTMF) service.
- d) A single integer value.
- e) EQPT.NbrSeizureAttDTMF
- f) MGW Function.
- g) Valid for circuit switched traffic.
- h) UMTS.

### 5.5.3.2 Number of successful DTMF seizures

- a) This measurement provides the number of successful attempts to seize DTMF services.
- b) CC.
- c) On sending of H.248 commands "Add Reply" or "Modify Reply" after the "Add Request" or "Modify Request" for DTMF Sending and Detection (DTMF) service has been successfully executed without any failure such as congestion.
- d) A single integer value.
- e) EQPT.NbrSeizureSuccDTMF
- f) MGW Function.
- g) Valid for circuit switched traffic.
- h) UMTS.

## 5.5.4 Global Text Telephony (GTT)

### 5.5.4.1 Number of seizure attempts for GTT

- a) This measurement provides the number of attempts to seize GTT services.
- b) CC.
- c) On receipt of H.248 commands "Add Request" or "Modify Request" for Global Text Telephony (GTT) service.
- d) A single integer value.
- e) EQPT.NbrSeizureAttGTT
- f) MGW Function.
- g) Valid for circuit switched traffic.
- h) UMTS.

#### 5.5.4.2 Number of successful GTT seizures

- a) This measurement provides the number of successful attempts to seize GTT services.
- b) CC.
- c) On sending of H.248 commands "Add Reply" or "Modify Reply" after the "Add Request" or "Modify Request" for Global Text Telephony (GTT) service has been successfully executed without any failure such as congestion.
- d) A single integer value.
- e) EQPT.NbrSeizureSuccGTT
- f) MGWFunction.
- g) Valid for circuit switched traffic.
- h) UMTS.

### 5.5.5 Media Frame Handler (MFH)

#### 5.5.5.1 Number of seizure attempts for MFH

- a) This measurement provides the number of attempts to seize MFH services.
- b) CC.
- c) On receipt of H.248 commands "Add Request" or "Modify Request" for Media Frame Handler (MFH) service.
- d) A single integer value.
- e) EQPT.NbrSeizureAttMFH
- f) MGWFunction.
- g) Valid for circuit switched traffic.
- h) UMTS.

#### 5.5.5.2 Number of successful MFH seizures

- a) This measurement provides the number of successful attempts to seize MFH services.
- b) CC.
- c) On sending of H.248 commands "Add Reply" or "Modify Reply" after the "Add Request" or "Modify Request" for Media Frame Handler (MFH) service has been successfully executed without any failure such as congestion.
- d) A single integer value.
- e) EQPT.NbrSeizureSuccMFH
- f) MGWFunction.
- g) Valid for circuit switched traffic.
- h) UMTS.



## 5.5.6 Multiparty Call (MPC)

### 5.5.6.1 Number of seizure attempts for MPC

- a) This measurement provides the number of attempts to seize MPC services.
- b) CC.
- c) On receipt of H.248 commands "Add Request" or "Modify Request" for Multiparty Call (MPC) service.
- d) A single integer value.
- e) EQPT.NbrSeizureAttMPC
- f) MGW Function.
- g) Valid for circuit switched traffic.
- h) UMTS.

### 5.5.6.2 Number of successful MPC seizures

- a) This measurement provides the number of successful attempts to seize MPC services.
- b) CC.
- c) On sending of H.248 commands "Add Reply" or "Modify Reply" after the "Add Request" or "Modify Request" for Multiparty Call (MPC) service has been successfully executed without any failure such as congestion.
- d) A single integer value.
- e) EQPT.NbrSeizureSuccMPC
- f) MGW Function.
- g) Valid for circuit switched traffic.
- h) UMTS.

## 5.5.7 Speech Coder (SC)

### 5.5.7.1 Number of seizure attempts for SC

- a) This measurement provides the number of attempts to seize SC services.
- b) CC.
- c) On receipt of H.248 commands "Add Request" or "Modify Request" for Speech Coder (SC) service.
- d) A single integer value.
- e) EQPT.NbrSeizureAttSC
- f) MGW Function.
- g) Valid for circuit switched traffic.
- h) UMTS.

### 5.5.7.2 Number of successful SC seizures

- a) This measurement provides the number of successful attempts to seize SC services.
- b) CC.
- c) On sending of H.248 commands "Add Reply" or "Modify Reply" after the "Add Request" or "Modify Request" for Speech Coder (SC) service has been successfully executed without any failure such as congestion.
- d) A single integer value.
- e) EQPT.NbrSeizureSuccSC
- f) MGWFunction.
- g) Valid for circuit switched traffic.
- h) UMTS.

## 5.5.8 Tone Sender or Line Test (TS)

### 5.5.8.1 Number of seizure attempts for TS

- a) This measurement provides the number of attempts to seize TS services.
- b) CC.
- c) On receipt of H.248 commands "Add Request" or "Modify Request" for Tone Sender or Line Test (TS) service.
- d) A single integer value.
- e) EQPT.NbrSeizureAttTS
- f) MGWFunction.
- g) Valid for circuit switched traffic.
- h) UMTS.

### 5.5.8.2 Number of successful TS seizures

- a) This measurement provides the number of successful attempts to seize TS services.
- b) CC.
- c) On sending of H.248 commands "Add Reply" or "Modify Reply" after the "Add Request" or "Modify Request" for Tone Sender or Line Test (TS) service has been successfully executed without any failure such as congestion.
- d) A single integer value.
- e) EQPT.NbrSeizureSuccTS
- f) MGWFunction.
- g) Valid for circuit switched traffic.
- h) UMTS.

---

## 6 Measurements related to the HLR

### 6.1 Equipment resource

#### 6.1.1 Overview

The clause provides the measurements related to HLR from equipment resource perspective.

#### 6.1.2 CPU LOAD

##### 6.1.2.1 Mean CPU usage

- a) This measurement provides the average CPU load during the measurement period.
- b) SI.
- c) This measurement is obtained by sampling at a pre-defined interval, CPU load and then taking the arithmetic mean.

For the product with centralized controlled CPUs, there should be one CPU load. There is only one sub-counter for this measurement. Its name should be .sum.

For the product with distributed controlled CPUs, there should be CPU load for each CPU. Processor ID could be used to differentiate those CPUs.

- d) A real value (Unit: 100 %).
- e) EQPT.CPUUsageMean.  
EQPT.CPUUsage.CPUid      load of each processor for distributed controlled mode.
- f) HLRFunction.
- g) Valid for circuit switched traffic.
- h) GSM/UMTS.

## 6.1.3 Subscribers related measurements

### 6.1.3.1 Subscribers in HLR

- a) This measurement provides average of various subscribers' number in HLR.
- b) SI.
- c) This measurement provides the number of subscribers located in the HLR. Trigger alternatives to identify 2G and 3G subscriber:
  - 1) one of the user parameters in HLR-video phone service parameter;
  - 2) access restriction data (3GPP TS 23.008 [18]) in HLR.
- d) Each measurement is an integer value.
- e) EQPT.NbrSubsInHlr

EQPT.NbrSubsInHlr.3Gsubs	Total 3G subscribers.
EQPT.NbrSubsInHlr.3GsubsForCsData	CSD 3G subscribers.
EQPT.NbrSubsInHlr.3GsubsforIN	IN 3G subscribers.
EQPT.NbrSubsInHlr.3GSubsforLCS	LCS 3G subscribers.
EQPT.NbrSubsInHlr.3GSubsforGPRS	GRPS 3G subscribers.

NOTE: GRPS 3G subscribers are those 3G user who have GPRS service.

EQPT.NbrSubsInHlr.3GsubsForRoamingNational	3G National roaming subscribers.
EQPT.NbrSubsInHlr.3GsubsForRoamingInternational	3G international roaming subscribers.
EQPT.NbrSubsInHlr.2Gsubs	2G subscribers.
EQPT.NbrSubsInHlr.2GsubsForIN	2G IN subscribers.
EQPT.NbrSubsInHlr.2GSubsForGPRS	2G GPRS subscribers.
EQPT.NbrSubsInHlr.2GsubsForRoamingNational	2G national roaming out subscribers.
EQPT.NbrSubsInHlr.2GsubsForRoamingInternational	2G international roaming out subscribers.

- f) HLRFunction.
- g) Valid for circuit switched and packet switched traffic.
- h) GSM/UMTS.

## 6.1.4 MTP3 signalling link related measurements

### 6.1.4.1 Number of unavailable times of MTP3 signalling link

- a) This measurement provides the number of unavailable times of signal link.
- b) CC.
- c) This measurement is obtained by addition of MTP3 signalling link unavailable occurrences over a granularity period.
- d) A single integer value.
- e) SIG.NbrMTP3LKUnavailable.
- f) SignLinkTp.
- g) Valid for circuit switched traffic.
- h) GSM/UMTS.

### 6.1.4.2 Number of MSUs received on MTP3 signalling link

- a) This measurement provides the number of message signal units received on signalling link(MSUs/SL, ITU-T Recommendation Q.752).
- b) CC.
- c) On receipt of a message signal unit.
- d) A single integer value.
- e) SIG.NbrMTP3MSUReceived.
- f) SignLinkTp.
- g) Valid for circuit switched traffic.
- h) GSM/UMTS.

### 6.1.4.3 Number of MSUs sent on MTP3 signalling link

- a) This measurement provides the number of message signal units sent on signalling link(MSUs/SL, ITU-T Recommendation Q.753 [23]).
- b) CC.
- c) On transmission of a message signal unit.
- d) A single integer value.
- e) SIG.NbrMTP3MSUSent
- f) SignLinkTp.
- g) Valid for circuit switched traffic.
- h) GSM/UMTS.

#### 6.1.4.4 Number of octets received on MTP3 signalling link

- a) This measurement provides the number of SIF and SIO octets received on signalling link(MSUs/SL, ITU-T Recommendation Q.753 [23]).
- b) CC.
- c) On receipt of a message signal unit.
- d) A single integer value.
- e) SIG.MTP3OctReceived.
- f) SignLinkTp.
- g) Valid for circuit switched traffic.
- h) GSM/UMTS.

#### 6.1.4.5 Number of octets sent on MTP3 signalling link

- a) This measurement provides the number of SIF and SIO octets sent on signalling link(MSUs/SL, ITU-T Recommendation Q.753 [23]).
- b) CC.
- c) On transmission of a message signal unit.
- d) A single integer value.
- e) SIG.MTP3OctSent.
- f) SignLinkTp.
- g) Valid for circuit switched traffic.
- h) GSM/UMTS.

#### 6.1.4.6 Number of available MTP3 signalling link

- a) This measurement provides the number of available MTP3 links, including signalling link in usage.
- b) GAUGE.
- c) Void
- d) A single integer value.
- e) SIG.NbrMTP3LKAavailable.
- f) SignLinkSetTp.
- g) Valid for circuit switched traffic.
- h) GSM/UMTS.

#### 6.1.4.7 Mean duration of unavailable MTP3 signalling link

- a) This measurement provides the mean duration of unavailable of signalling link.
- b) DER(n=1).
- c) This measurement is obtained by accumulating the time intervals for beginning of unavailable of MTP3 signalling link to the end of unavailable of MTP3 signalling link over a granularity period using DER, see 3GPP TS 25.413 [5].
- d) a real value.(Unit: second).
- e) SIG.MTP3LKUnavailableDurationMean
- f) SignLinkTp.
- g) Valid for circuit switched traffic.
- h) GSM/UMTS.

---

## Annex A (informative): Examples for "(n-1) out of n" approach

See 3GPP TS 32.404 [8], annex A.

---

### A.1 Attempt/success/failure procedure measurements

See 3GPP TS 32.404 [8], clause A.1.

---

### A.2 GSM/UMTS combined measurements

See 3GPP TS 32.404 bedded "(n-1) out of n" approaches

See 3GPP TS 32.404 [8], clause A.3.



---

## Annex B (informative): Top-Down Performance Measurement Definition Process

See 3GPP TS 32.404 [8] clause B.

---

## Annex C (normative): Use cases for performance measurements definition

The present Annex provides the concrete use cases for the CS performance measurements defined in the present specification.

---

### C.1 Use case of the Mean delay Jitter on Nb interface related measurements

The present maximum delay and maximum delay jitter on Nb interface related measurements are "worst case" value. If maximum value is big and mean value is small, this means that network quality is good. If maximum value and mean value are all big, this means network quality is bad. Both mean value and maximum value could help operator to evaluate the network performance.

---

### C.2 Use case of the Mean delay Jitter on Nb interface related measurements

The present maximum delay and maximum delay jitter on Nb interface related measurements are "worst case" value. If maximum value is big and mean value is small, this means that network quality is good. If maximum value and mean value are all big, this means network quality is bad. Both mean value and maximum value could help operator to evaluate the network performance.

---

### C.3 Use case of number of subscribers in VLR

The number of subscribers in VLR per LAC related measurements are very useful to analyze network load balance and predict traffic per LAC. Operator could also optimize the network resources per LAC based on the measurements.

---

### C.4 Use case of Number of Handover Intra MSC-S

Handover successful rate is an important index in network management. If the handover successful rate is reduced, the probability of drop session will be risen and the network operation performance will be reduced. Besides handover inter MSC-S, handover intra MSC-S related measurements could complete handover scenario related measurements.

---

## Annex E (informative): Use case for measurements

### E.1 Use case for Iu-CS and A-Interface related MO/MT and traffic measurements

Call originated and terminated from each BSC and / or each RNC related measurements are very useful to learn the call related performance per BSC or RNC, such as call drop rate. Since it is difficult to meet the requirement of call related performance per BSC or RNC from existing performance measurement based on MSCServerFunction, especially in the case MSC pool is used. So it is necessary to define MO/MT related measurements based on A-Interface and Iu-CS object.

Call traffic from each BSC and / or each RNC related measurements are useful to learn traffic distribution to evaluate load balance performance. So it is necessary to define measurement related to traffic based on A-Interface and Iu-CS object.

## Annex E (informative): Change history

Change history								
Date	TSG #	TSG Doc.	CR	R	Subject/Comment	Cat	Old	New
Sep 2006	SA_33	SP-060557	--	--	Submitted to SA#33 for Information	--	1.0.0	
Mar 2007	SA_35	SP-070061	--	--	Submitted to SA#35 for Approval	--	2.0.0	7.0.0
Jun 2007	SA_36	SP-070278	0001	--	Corrections of terminology, incorrect character usage and redundant terms.	F	7.0.0	7.1.0
Jun 2007	SA_36	SP-070278	0002	--	Correction of trigger conditions for TDM call related measurements	F	7.0.0	7.1.0
Jun 2007	SA_36	SP-070276	0003	--	Correct the undefined MOC "Trunkgroup"	F	7.0.0	7.1.0
Jun 2007	SA_36	SP-070278	0004	--	Add missing MGW measurements for user plane services, related to call loss	F	7.0.0	7.1.0
Sep 2008	SA_41	SP-081209	0005	--	Incorrect description of information flow for paging related performance.	F	7.1.0	7.2.0
Dec 2008	SA_42	--	--	--	Upgrade to Release 8	--	7.2.0	8.0.0
Dec 2009	--	--	--	--	Upgrade to Release 9	--	8.0.0	9.0.0
Sep 2010	SA_49	SP-100489	0006	--	Correct the data type of Measurement Result in Mobile terminating call traffic	F	9.0.0	10.0.0
May 2011	SA_52	SP-110288	0008	1	Correcting the measurement definitions	A	10.0.0	10.1.0
Sep 2011	SA_53	SP-110535	0009	--	Add the mean delay and mean delay jitter on lu interface	B	10.1.0	11.0.0
Sep 2011	SA_53	SP-110535	0010	--	Add the mean delay and mean delay jitter on Nb interface	B	10.1.0	11.0.0
Sep 2011	SA_53	SP-110535	0011	--	Correct the number of subscribers in VLR	F	10.1.0	11.0.0
Sep 2011	SA_53	SP-110535	0012	--	Add Number of Handover Intra MSC-S related measurements	B	10.1.0	11.0.0
Sep 2011	SA_53	SP-110535	0013	1	Addition of lucslink and Alink related MT MO calls and traffic measurements	B	10.1.0	11.0.0
Dec 2011	SA_54	SP-110704	0017	--	Correcting measurement definitions	A	11.0.0	11.1.0
March 2012	SA_55	SP-120044	0020	--	Correcting the codec modification related measurements to eliminate wrong KPI results	A	11.1.0	11.2.0