

3GPP TS 32.366 V11.0.0 (2012-09)

Technical Specification

**3rd Generation Partnership Project;
Technical Specification Group Services and System Aspects;
Telecommunication management;
Entry Point (EP) Integration Reference Point (IRP);
Solution Set (SS) definitions
(Release 11)**



The present document has been developed within the 3rd Generation Partnership Project (3GPPTM) and may be further elaborated for the purposes of 3GPP. The present document has not been subject to any approval process by the 3GPP Organizational Partners and shall not be implemented. This Specification is provided for future development work within 3GPP only. The Organizational Partners accept no liability for any use of this Specification. Specifications and reports for implementation of the 3GPPTM system should be obtained via the 3GPP Organizational Partners' Publications Offices.

Keywords

management, architecture, entry point,
CORBA, XML, SOAP

3GPP

Postal address

3GPP support office address

650 Route des Lucioles - Sophia Antipolis
Valbonne - FRANCE
Tel.: +33 4 92 94 42 00 Fax: +33 4 93 65 47 16

Internet

<http://www.3gpp.org>

Copyright Notification

No part may be reproduced except as authorized by written permission.
The copyright and the foregoing restriction extend to reproduction in all media.

© 2012, 3GPP Organizational Partners (ARIB, ATIS, CCSA, ETSI, TTA, TTC).
All rights reserved.

UMTS™ is a Trade Mark of ETSI registered for the benefit of its members
3GPP™ is a Trade Mark of ETSI registered for the benefit of its Members and of the 3GPP Organizational Partners
LTE™ is a Trade Mark of ETSI currently being registered for the benefit of its Members and of the 3GPP Organizational Partners
GSM® and the GSM logo are registered and owned by the GSM Association

Contents

Foreword	5
Introduction	5
1 Scope.....	6
2 References.....	6
3 Definitions and abbreviations	7
3.1 Definitions.....	7
3.2 Abbreviations.....	7
4 Solution Set definitions	7
Annex A (normative): CORBA Solution Set.....	8
A.1 Architectural Features	8
A.1.1 Syntax for Distinguished Names and Versions.....	8
A.1.2 Notifications	8
A.2 Mapping.....	8
A.2.1 Operation and Notification mapping	8
A.2.2 Operation parameter mapping	8
A.2.3 Notification parameter mapping	10
A.3 EPIRPNotification Interface	11
A.3.1 Method <code>push (M)</code>	11
A.4 Solution Set definitions	12
A.4.1 IDL definition structure.....	12
A.4.2 IDL specification “EPIRPConstDefs.idl”	13
A.4.3 IDL specification “EPIRPSystem.idl”	15
A.4.4 IDL specification “EPIRPNotifications.idl”	17
A.5 Convention when using INS to fulfill part of EPIRP functions	18
Annex B (normative): XML definitions.....	20
B.1 Architectural features	20
B.1.1 Syntax for Distinguished Names	20
B.2 Mapping.....	20
B.3 Solution Set definitions	20
B.3.1 XML definition structure	20
B.3.2 Graphical Representation.....	20
B.3.3 XML Schema “ePIRPNotif.xsd”.....	21
Annex C (normative): SOAP Solution Set.....	22
C.1 Architectural Features	22
C.1.1 Syntax for Distinguished Names and versions.....	22
C.1.2 General	22
C.2 Mapping.....	23
C.2.1 Operation and Notification mapping	23
C.2.2 Operation parameter mapping.....	23
C.2.2.1 Operation <code>getIRPOutline</code>	23
C.2.2.1.1 Input parameters.....	23
C.2.2.1.2 Output parameters.....	24
C.2.2.1.3 Fault definition	24
C.2.2 Operation <code>getIRPReference</code>	24
C.2.2.2.1 Input parameters.....	24
C.2.2.2.2 Output parameters.....	24

C.2.2.2.3 Fault definition24

C.2.2.3 Operation releaseIRPReference25

C.2.2.3.1 Input parameters25

C.2.2.3.2 Output parameters25

C.2.2.3.3 Fault definition25

C.3 Solution Set definitions 25

C.3.1 WSDL definition structure.....25

C.3.2 Graphical Representation25

C.3.3 WSDL specification “EntryPointIRPSystem.wsdl”27

Annex D (informative): Change history..... 30

Foreword

This Technical Specification has been produced by the 3rd Generation Partnership Project (3GPP).

The contents of the present document are subject to continuing work within the TSG and may change following formal TSG approval. Should the TSG modify the contents of the present document, it will be re-released by the TSG with an identifying change of release date and an increase in version number as follows:

Version x.y.z

where:

- x the first digit:
 - 1 presented to TSG for information;
 - 2 presented to TSG for approval;
 - 3 or greater indicates TSG approved document under change control.
- y the second digit is incremented for all changes of substance, i.e. technical enhancements, corrections, updates, etc.
- z the third digit is incremented when editorial only changes have been incorporated in the document.

Introduction

The present document is part of a TS-family covering the 3rd Generation Partnership Project: Technical Specification Group Services and System Aspects; Telecommunication management; as identified below:

- 32.361: "Entry Point (EP) Integration Reference Point (IRP): Requirements"
- 32.362: "Entry Point (EP) Integration Reference Point (IRP): Information Service (IS)"
- 32.366: "Entry Point (EP) Integration Reference Point (IRP): Solution Set (SS) definitions"**

The present document is part of a set of technical specifications defining the Telecommunication Management (TM) of 3G systems. The TM principles are described in 3GPP TS 32.101 [1]. The TM architecture is described in 3GPP TS 32.102 [2]. The other specifications define the interface (Itf-N) between the managing system (manager), which is in general the Network Manager (NM) and the managed system (agent), which is either an Element Manager (EM) or the managed NE itself. The Itf-N is composed of a number of Integration Reference Points (IRPs) defining the information in the agent that is visible for the manager, the operations that the manager may perform on this information and the notifications that are sent from the agent to the manager. EP (Entry Point) IRP is one of these IRPs with special function.

It's difficult for an NM to discover all IRPs in the environment that there are several managed systems and/or if there are multiple IRPs related to each managed systems. This Entry Point is proposed to provide a convenient mechanism for NM to discover the managed systems and their related IRPs.

1 Scope

The present document specifies the Solution Set definitions for the IRP whose semantics are specified in the Entry Point IRP: Information Service (3GPP TS 32.362 [6]).

This Solution Set definitions specification is related to 3GPP TS 32.362 V11.0.X.

2 References

The following documents contain provisions which, through reference in this text, constitute provisions of the present document.

- References are either specific (identified by date of publication, edition number, version number, etc.) or non-specific.
- For a specific reference, subsequent revisions do not apply.
- For a non-specific reference, the latest version applies. In the case of a reference to a 3GPP document (including a GSM document), a non-specific reference implicitly refers to the latest version of that document *in the same Release as the present document*.

- [1] 3GPP TS 32.101: "Telecommunication management; Principles and high level requirements".
- [2] 3GPP TS 32.102: "Telecommunication management; Architecture".
- [3] 3GPP TS 32.361: "Telecommunication management; Entry Point (EP) Integration Reference Point (IRP): Requirements".
- [4] 3GPP TS 32.312: "Telecommunication management; Generic Integration Reference Point (IRP): Information Service (IS)".
- [5] 3GPP TS 32.311: "Telecommunication management; Generic Integration Reference Point (IRP): Requirements".
- [6] 3GPP TS 32.362: "Telecommunication management; Entry Point (EP) Integration Reference Point (IRP): Information Service (IS)".
- [7] 3GPP TS 32.306: "Telecommunication management; Configuration Management (CM); Notification Integration Reference Point (IRP): Solution Set (SS) definitions".
- [8] OMG TC Document telecom/98-11-01: "OMG Notification Service".
<http://www.omg.org/technology/documents/>
- [9] 3GPP TS 32.300: "Telecommunication management; Configuration Management (CM); Name convention for Managed Objects".
- [10] ITU-T Recommendation Q.816.1 Recommendation "CORBA based TMN services: Extensions to support coarse-grained interfaces".
- [11] OMG TC Document telecom/98-12-09: "CORBA services: Common Object Services Specification".
<http://www.omg.org/technology/documents/>
- [12] ISO 8859-1: "Information technology - 8-bit single-byte coded graphic character sets - Part 1: Latin alphabet No. 1".
- [13] 3GPP TS 32.336: "Telecommunication management; Notification Log (NL) Integration Reference Point (IRP): Solution Set (SS) definitions".
- [14] 3GPP TS 32.331: "Telecommunication management; Notification Log (NL) Integration Reference Point (IRP): Requirements".

- [15] 3GPP TS 32.316: "Telecommunication management; Generic Integration Reference Point (IRP) management; Solution Set (SS) definitions".
- [16] 3GPP TS 32.150: "Telecommunication management; Integration Reference Point (IRP) Concept and definitions".
- [17] W3C SOAP 1.1 specification (<http://www.w3.org/TR/2000/NOTE-SOAP-20000508/>)
- [18] W3C XPath 1.0 specification (<http://www.w3.org/TR/1999/REC-xpath-19991116>)
- [19] W3C WSDL 1.1 specification (<http://www.w3.org/TR/2001/NOTE-wsdl-20010315>)
- [20] W3C SOAP 1.2 specification (<http://www.w3.org/TR/soap12-part1/>)

3 Definitions and abbreviations

3.1 Definitions

For the purposes of the present document, the terms and definitions defined in 3GPP TS 32.101 [1], 3GPP TS 32.102 [2], 3GPP TS 32.361 [3], 3GPP TS 32.331 [14], 3GPP TS 32.150 [16] and the following apply:

IRP document version number string (or "IRPVersion"): See 3GPP TS 32.311 [5].

3.2 Abbreviations

For the purposes of the present document, the following abbreviations apply:

CORBA	Common Object Request Broker Architecture
DN	Distinguished Name
EM	Element Manager
EP	Entry Point
EPIRP	Entry Point IRP
IRP	Integration Reference Point
IOC	Information Object Class
IS	Information Service
NE	Network Element
NL	Notification Log
NM	Network Manager
SS	Solution Set
WSDL	Web Service Description Language
XML	eXtensible Markup Language

4 Solution Set definitions

This specification defines the following 3GPP EP IRP Solution Set definitions:

- 3GPP EP IRP CORBA SS (Annex A)
- 3GPP EP IRP XML definitions (Annex B)
- 3GPP EP IRP SOAP Solution Set (Annex C)

Annex A (normative): CORBA Solution Set

This annex contains the CORBA Solution Set for the IRP whose semantics is specified in EP IRP: Information Service (TS 32.362 [6]).

A.1 Architectural Features

The overall architectural feature of EP IRP is specified in 3GPP TS 32.362 [6].

This clause specifies features that are specific to the CORBA SS.

A.1.1 Syntax for Distinguished Names and Versions

The syntax of a Distinguished Name is defined in 3GPP TS 32.300 [9].

The version of this IRP is represented as a string (see also clause 3 for versions).

A.1.2 Notifications

Notifications are sent according to the Notification IRP: CORBA SS (see 3GPP TS 32.306 [7]).

The contents of the EP IRP notifications are defined in the present document.

A.2 Mapping

A.2.1 Operation and Notification mapping

EPIRP: IS (3GPP TS 32.362 [6]) defines semantics of operation and notification visible across the EPIRP.

Table A.2.1 indicates the mapping of these operations and notifications to their equivalents defined in this SS.

Table A.2.1: Mapping from IS Operations and Notification to SS equivalents

IS Operations/ notification TS 32.362 [6]	SS Method	Qualifier
getIRPOutline	get_irp_outline	M
getIRPReference	get_irp_reference	M
releaseIRPReference	release_irp_reference	M
notifyIRPInfoChanges	push_structured_event (See clause A.3.1)	M
getIRPVersion (see note)	get_ep_irp_versions	M
getOperationProfile (see note)	get_ep_irp_operations_profile	O
getNotificationProfile (see note)	get_ep_irp_notification_profile	O
NOTE: This operation is of ManagedGenericIRP IOC specified in 3GPP TS 32.312 [4]. The EPIRP IOC of 3GPP TS 32.362 [6] inherits from it.		

A.2.2 Operation parameter mapping

The EPIRP: IS 3GPP TS 32.362 [6] defines semantics of parameters carried in operations across the EPIRP. The following tables indicate the mapping of these parameters, as per operation, to their equivalents defined in this SS.

Table A.2.2.1: Mapping from IS `getIRPOutline` parameters to SS equivalents

IS Operation parameter	SS Method parameter	Qualifier
<code>irpVersion</code>	<code>ManagedGenericIRPConstDefs::VersionNumber irp_version</code>	M
<code>supportedIRPList</code>	<code>EPIRPConstDefs::SupportedIRPList supported_irp_list</code>	M
<code>status</code>	Return value of type <code>EPIRPConstDefs::Result</code> Exception: <code>GetIRPOutline</code> , <code>InvalidIRPVersion</code>	M

Table A.2.2.2: Mapping from IS `getIRPReference` parameters to SS equivalents

IS Operation parameter	SS Method parameter	Qualifier
<code>managerIdentifier</code>	<code>EPIRPConstDefs::ManagerIdentifier manager_identifier</code>	M
<code>systemDn</code>	<code>EPIRPConstDefs::DN system_dn</code>	M
<code>rDN</code>	<code>EPIRPConstDefs::RDN r_DN</code>	M
<code>irpReference</code>	<code>string irp_reference</code> (stringified IOR)	M
<code>status</code>	Return value of type <code>EPIRPConstDefs::Result</code> Exception: <code>GetIRPReference</code> , <code>ManagedGenericIRPSystem::InvalidParameter</code>	M

Table A.2.2.3: Mapping from IS `releaseIRPReference` parameters to SS equivalents

IS Operation parameter	SS Method parameter	Qualifier
<code>managerIdentifier</code>	<code>EPIRPConstDefs::ManagerIdentifier manager_identifier</code>	M
<code>irpReference</code>	<code>string irp_reference</code> (stringified IOR)	M
<code>status</code>	Return value of type <code>EPIRPConstDefs::Result</code> Exception: <code>ReleaseIRPReference</code> , <code>UnknownIRPReference</code>	M

Table A.2.2.4: Mapping from IS `getIRPVersion` parameters to SS equivalents

IS Operation parameter	SS Method parameter	Qualifier
<code>versionNumberSet</code>	Return value of type <code>ManagedGenericIRPConstDefs::VersionNumberSet</code>	M
<code>status</code>	Exception: <code>GetEPIRPVersions</code>	M

Table A.2.2.5: Mapping from IS `getOperationProfile` parameters to SS equivalents

IS Operation parameter	SS Method parameter	Qualifier
<code>irpVersion</code>	<code>ManagedGenericIRPConstDefs::VersionNumber irp_version</code>	M
<code>operationNameProfile</code> , <code>operationParameterProfile</code>	Return value of type <code>ManagedGenericIRPConstDefs::MethodList</code>	M
<code>status</code>	Exception: <code>GetEPIRPOperationsProfile</code> , <code>ManagedGenericIRPSystem::OperationNotSupported</code> , <code>ManagedGenericIRPSystem::InvalidParameter</code>	M

Table A.2.2.6: Mapping from IS `getNotificationProfile` parameters to SS equivalents

IS Operation parameter	SS Method parameter	Qualifier
<code>irpVersion</code>	<code>ManagedGenericIRPConstDefs::VersionNumber irp_version</code>	M
<code>notificationNameProfile</code> , <code>notificationParameterProfile</code>	Return value of type <code>ManagedGenericIRPConstDefs::MethodList</code>	M
<code>status</code>	Exception: <code>GetEPIRPNotificationProfile</code> , <code>ManagedGenericIRPSystem::OperationNotSupported</code> , <code>ManagedGenericIRPSystem::InvalidParameter</code>	M

A.2.3 Notification parameter mapping

The EPIRP: IS (3GPP TS 32.362 [6]) defines semantics of parameters carried in notifications. The following table indicates the mapping of these parameters to their OMG CORBA Structured Event (defined in OMG Notification Service [8]) equivalents. The composition of OMG Structured Event, as defined in the OMG Notification Service [8], is:

```
Header
  Fixed Header
    domain_name
    type_name
    event_name
  Variable Header
Body
  filterable_body_fields
  remaining_body
```

The following table lists all OMG Structured Event attributes in the second column. The first column identifies the EPIRP: IS (3GPP TS 32.362 [6]) defined notification parameters.

Table A.2.3: Mapping for notifyIRPInfoChanges

IS Parameters	OMG CORBA Structured Event attribute	Qualifier	Comment
There is no corresponding IS attribute.	domain_name	M	It carries the IRP document version number string. See clause 3.1. It indicates the syntax and semantics of the Structured Event as defined by the present document.
notificationType	type_name	M	This is the ET_IRPINFO_CHANGES of module of EPIRPSystem.
There is no corresponding IS attribute.	event_name	M	It carries no information.
There is no corresponding IS attribute.	Variable Header		
objectClass, objectInstance	One NV pair of filterable_body_fields	M	NV stands for name-value pair. Order arrangement of NV pairs is not significant. The name of NV-pair is always encoded in string. Name of this NV pair is the MANAGED_OBJECT_INSTANCE of interface AttributeNameValue of module NotificationIRPConstDefs. Value of NV pair is a string. See corresponding table in Notification IRP: CORBA SS (3GPP TS 32.306 [7]).
notificationId	One NV pair of remaining_body	M	Name of NV pair is the NOTIFICATION_ID of interface AttributeNameValue of module NotificationIRPConstDefs. Value of NV pair is a long. See corresponding table in Notification IRP: CORBA SS (3GPP TS 32.306 [7]).
eventTime	One NV pair of filterable_body_fields	M	Name of NV pair is the EVENT_TIME of interface AttributeNameValue of module NotificationIRPConstDefs. Value of NV pair is IRPTime. See corresponding table in Notification IRP: CORBA SS (3GPP TS 32.306 [7]).
systemDN	One NV pair of filterable_body_fields	M	Name of NV pair is the SYSTEM_DN of interface AttributeNameValue of module NotificationIRPConstDefs. Value of NV pair is a string. See corresponding table in Notification IRP: CORBA SS (3GPP TS 32.306 [7]).
iRPDn	One NV pair of remaining_body	M	Name of NV pair is the IRP_DN of interface NotifyIRPInfoChanges of module EPIRPNotifications. Value of NV pair is a EPIRPConstDefs::DN.
changeMode	One NV pair of remaining_body	M	Name of NV pair is the CHANGE_MODE of interface NotifyIRPInfoChanges of module EPIRPNotifications. Value of NV pair is a EPIRPConstDefs::ChangeMode.
additionalText	One NV pair of remaining_body	M	Name of NV pair is the ADDITIONAL_TEXT of interface NotifyIRPInfoChanges of module EPIRPNotifications. Value of NV pair is a string.

A.3 EPIRPNotification Interface

OMG CORBA Notification push operation is used to realise the notification of EPIRPNotifications. All the notifications in this interface are implemented using this `push_structured_event` method.

A.3.1 Method `push` (M)

```
module CosNotifyComm {
    ...
    Interface SequencePushConsumer : NotifyPublish {
```

```
        void push_structured_events(  
            in CosNotification::EventBatch notifications)  
        raises ( CosEventComm::Disconnected);  
        ...  
    }; // SequencePushConsumer  
    ...  
}; // CosNotifyComm
```

- 1) The `push_structured_events` method takes an input parameter of type `EventBatch` as defined in the `OMG CosNotification` module (OMG Notification Service [8]). This data type is the same as a sequence of Structured Events. Upon invocation, this parameter shall contain a sequence of Structured Events being delivered to `IRPManager` by `IRPAgent` to which it is connected.
- 2) The maximum number of events that shall be transmitted within a single invocation of this operation is controlled by `IRPAgent` wide configuration parameter.
- 3) The amount of time the supplier (`IRPAgent`) of a sequence of Structured Events shall accumulate individual events into the sequence before invoking this operation is controlled by `IRPAgent` wide configuration parameter as well.
- 4) `IRPAgent` may push `EventBatch` with only one Structured Event.

A.4 Solution Set definitions

A.4.1 IDL definition structure

Clause A.4.2 defines the constants and types used by the EP IRP.

Clause A.4.3 defines the operations which are performed by the EP IRP agent.

Clause A.4.4 defines the notifications which are performed by the EP IRP agent.

A.4.2 IDL specification “EPIRPConstDefs.idl”

```

//File: EPIRPConstDefs.idl
#ifndef EP_IRP_CONST_DEFS_IDL
#define EP_IRP_CONST_DEFS_IDL

#include <ManagedGenericIRPConstDefs.idl>

// This statement must appear after all include statements
#pragma prefix "3gppsa5.org"

/* ## Module: EPIRPSystem
*/
module EPIRPConstDefs
{
    enum Result {OK, FAILURE};
    /*
    The RDN carries an optional instance class name and a mandatory
    instance identifier. This type (a string) may contain 0 or 1
    equal sign. If an equal sign is present, the substring before
    the equal sign is the class name, and the substring after the
    equal sign is the instance identifier. If the equal sign is
    absent, the entire string is the instance identifier.
    */

    typedef string RDN;
    typedef string DN;
    typedef sequence<DN> DNList;

    /*
    IRPManagementScopeOpt is a type carrying an optional parameter.
    If the boolean is TRUE, then the value is present.
    Otherwise the value is absent.
    */
    union IRPManagementScopeOpt switch (boolean)
    {
        case TRUE: DNList value;
    };

    /*
    The IRPElement defines the structure to be returned as part of
    get_irp_outline().
    */
    struct IRPElement
    {
        RDN r_DN;
        ManagedGenericIRPConstDefs::VersionNumberSet irp_versions;
        IRPManagementScopeOpt irp_management_scope;
    };

    /*
    List of all IRPElement and their associated parameters.
    */
    typedef sequence<IRPElement> IRPList;

    struct SupportedIRP
    {
        DN system_dn;
        IRPList irp_list;
    };

    typedef sequence<SupportedIRP> SupportedIRPList;

    typedef string ManagerIdentifier;

    enum ChangeMode {REGISTER, DEREGISTER, MODIFY};

    /*
    Define the parameters specified in
    the notifyEpInfoChanges notification.
    */
    interface AttributeNameValue
    {
        const string IRP_DN = "IRP_DN";
        const string CHANGE_MODE = "CHANGE_MODE";
        const string ADDITIONAL_TEXT = "ADDITIONAL_TEXT";
    };
}

```

```
};  
};  
#endif// _EP_IRP_CONST_DEFS_IDL_
```

A.4.3 IDL specification “EPIRPSystem.idl”

```

//File: EPIRPSystem.idl
#ifndef _EP_IRP_SYSTEM_IDL_
#define _EP_IRP_SYSTEM_IDL_

#include <ManagedGenericIRPConstDefs.idl>
#include <ManagedGenericIRPSystem.idl>
#include <EPIRPCConstDefs.idl>

// This statement must appear after all include statements
#pragma prefix "3gppsa5.org"

/* ## Module: EPIRPSystem
*/
module EPIRPSystem
{
    exception InvalidIRPVersion { string reason; };
    exception UnknownIRPReference { string reason; };

    /*
    System fails to complete the operation. System can provide reason
    to qualify the exception. The semantics carried in reason
    is outside the scope of this IRP.
    */
    exception GetIRPOutline { string reason; };
    exception GetIRPReference { string reason; };
    exception ReleaseIRPReference { string reason; };
    exception GetEPIRPVersions { string reason; };
    exception GetEPIRPOperationsProfile { string reason; };
    exception GetEPIRPNotificationProfile { string reason; };

    interface EPIRP
    {
        /**
        * The IRPManager uses this operation to request the EPIRP to
        * return the outline information of the supported IRPs. The EPIRP
        * shall return the outline information of all the IRPs supported by the
        * IRPAgent that contains the EPIRP. The EPIRP may
        * additionally return the outline information of all the IRPs supported
        * by other IRPAgents.
        */
        EPIRPCConstDefs::Result get_irp_outline(
            in ManagedGenericIRPConstDefs::VersionNumber irp_version,
            out EPIRPCConstDefs::SupportedIRPList supported_irp_list
        )
        raises (GetIRPOutline, InvalidIRPVersion);

        /**
        * The IRPManager uses this operation to request the EPIRP to return
        * the stringified IOR of the IRP identified by system_dn and r_DN.
        */
        EPIRPCConstDefs::Result get_irp_reference(
            in EPIRPCConstDefs::ManagerIdentifier manager_identifier,
            in EPIRPCConstDefs::DN system_dn,
            in EPIRPCConstDefs::RDN r_DN,
            out string irp_reference
        )
        raises (GetIRPReference,
            ManagedGenericIRPSystem::InvalidParameter);

        /**
        * The IRPManager uses this operation to request the IRPAgent to
        * release a specific IRP reference. Whether the IRP reference
        * is really released or not in the IRPAgent is outside the
        * scope of this document.
        */
        EPIRPCConstDefs::Result release_irp_reference(
            in EPIRPCConstDefs::ManagerIdentifier manager_identifier,
            in string irp_reference
        )
        raises (ReleaseIRPReference,
            UnknownIRPReference);

        /**

```

```
* Return the list of all supported EPIRP versions.
*/
ManagedGenericIRPConstDefs::VersionNumberSet get_ep_irp_versions (
)
raises (GetEPIRPVersions);

/**
* Return the list of all supported operations and their supported
* parameters for a specific EPIRP version.
*/
ManagedGenericIRPConstDefs::MethodList get_ep_irp_operations_profile (
    in ManagedGenericIRPConstDefs::VersionNumber irp_version
)
raises (GetEPIRPOperationsProfile,
        ManagedGenericIRPSystem::OperationNotSupported,
        ManagedGenericIRPSystem::InvalidParameter);

/**
* Return the list of all supported notifications and their supported
* parameters for a specific EPIRP version.
*/
ManagedGenericIRPConstDefs::MethodList get_ep_irp_notification_profile
(
    in ManagedGenericIRPConstDefs::VersionNumber irp_version
)
raises (GetEPIRPNotificationProfile,
        ManagedGenericIRPSystem::OperationNotSupported,
        ManagedGenericIRPSystem::InvalidParameter);
};

};

#endif // _EP_IRP_SYSTEM_IDL_
```

A.4.4 IDL specification “EPIRPNotifications.idl”

```
//File: EPIRPNotifications.idl
#ifndef _EP_IRP_NOTIFICATIONS_IDL_
#define _EP_IRP_NOTIFICATIONS_IDL_

#include <NotificationIRPNotifications.idl>
#include <EPIRPConstDefs.idl>

// This statement must appear after all include statements
#pragma prefix "3gppsa5.org"

/* ## Module: EPIRPNotifications
*/
module EPIRPNotifications
{
    interface NotifyIRPInfoChanges: NotificationIRPNotifications::Notify
    {
        const string ET_IRPINFO_CHANGES = "notifyIrpInfoChanges";

        /**
         * This constant defines the name of the iRPDn property.
         * The data type for the value of this property
         * is DN.
         */
        const string IRP_DN =
            EPIRPConstDefs::AttributeNameValue::IRP_DN;

        /**
         * This constant defines the name of the changeMode property.
         * The data type for the value of this property is ChangeMode.
         */
        const string CHANGE_MODE =
            EPIRPConstDefs::AttributeNameValue::CHANGE_MODE;

        /**
         * This constant defines the name of the additionalText property.
         * The data type for the value of this property is string.
         */
        const string ADDITIONAL_TEXT =
            EPIRPConstDefs::AttributeNameValue::ADDITIONAL_TEXT;
    };
};

#endif // _EP_IRP_NOTIFICATIONS_IDL_
```

A.5 Convention when using INS to fulfill part of EPIRP functions

The implementation of the EPIRP and in particular, the management of CORBA object references within EPIRP, is not a subject matter for 3GPP standardization.

ITU-T SG4 Framework for CORBA-Based Telecommunications Management Network Interfaces (ITU-T Recommendation Q.816.1 [10]) uses OMG Interoperable Naming Service (INS) [11] for the management of CORBA object references. Furthermore, it specifies a convention to name and populate the CORBA object entries within the INS.

This Annex notes that, in the event that an EPIRP implementation uses INS to fulfill part of EPIRP functions, it is advantageous to populate the INS using the ITU-T defined convention.

Convention

The OMG INS CORBA *name component* (in short, called CORBA compound name) has the following IDL definition:

```
// IDL
typedef string Istring;
struct NameComponent {
    Istring id;
    Istring kind;
};
```

Istring is a placeholder for a future IDL internationalized string. The *id* and *kind* attributes must be composed of characters from the ISO 8859-1 [12] character set, excluding the null character and other non-printable characters. The strings cannot exceed 255 characters. The *id* attribute cannot be an empty string but the *kind* attribute can be an empty string.

The CORBA compound name (see *Name* below) is defined as a sequence of name components:

```
// IDL
typedef sequence<NameComponent> Name;
```

The 3GPP defined DN (in short, called DN) of a managed object is represented by the CORBA *compound name*. For example, a DN, quoted from 3GPP TS 32.300 [9], say “DC=se.companyZ.lmc, Network=9, SubNetwork=1, IRPAgent=1, AlarmIRP.iRPId=2”, shall be represented by a sequence of 6 *name components* where the *id* and *kind* of the first *name component* shall be “se_companyZ_lmc” and “DC” respectively. The CORBA *compound name*, shall be:

index	kind	id
0	“DC”	“se_companyZ_lmc”
1	“Network”	“9”
2	“SubNetwork”	“1”
3	“IRPAgent”	“1”
4	“AlarmIRP.iRPId”	“2”
5	“”	“Object”

The CORBA *compound name*, in stringified name form, shall be “se_companyZ_lmc.DC/9.Network/1.SubNetwork/1.IRPAgent/2.AlarmIRP.iRPId/Object”.

NOTE 1: DN appears in interactions (e.g. operations, notifications) across the Itf-N.

NOTE 2: The CORBA compound name is used internally with the IRPAgent (and its INS) and does not appear in interactions across the Itf-N.

The use of the last row of the CORBA *compound name*, i.e. kind == "" and id == "Object", is in accordance to the convention standardized by ITU-T Recommendation Q.816.1 [10]. According to convention standardized by ITU-T Recommendation Q.816.1 [10], the use of index 0 to 4 inclusive is to indicate the naming context of the object and the use of index 0 to 5 inclusive is to indicate the object itself.

DN DC component is composed of multiple words separated by separator, i.e. a dot. It is suggested that the applications (e.g. IRPAgent codes) that process CORBA compound name and DN should map the dot, used as separator in DN DC component, with underscore. This mapping is necessary because in the stringified CORBA *compound name*, the dot is used for the separation of *id* and *kind*. This replacement rule also implies that underscore should not be used as character of DC words.

Annex B (normative): XML definitions

The annex specifies the XML Definitions for the EP Integration Reference Point (IRP) as it applies to Itf-N, in accordance with EP IRP IS definitions [6], for usage with the Notification Log IRP XML Definitions [13].

B.1 Architectural features

The overall architectural feature of EP IRP is specified in 3GPP TS 32.352 [6].

This clause specifies features that are specific to the XML Schema definitions.

B.1.1 Syntax for Distinguished Names

The syntax of a Distinguished Name is defined in 3GPP TS 32.300 [9].

B.2 Mapping

Not present in the current version of this specification.

B.3 Solution Set definitions

B.3.1 XML definition structure

Clause B.3.2 provides a graphical representation of the XML elements.

Clause B.3.3 provides XML definitions of EP IRP notifications as defined in 3GPP TS 32.362 [6].

B.3.2 Graphical Representation

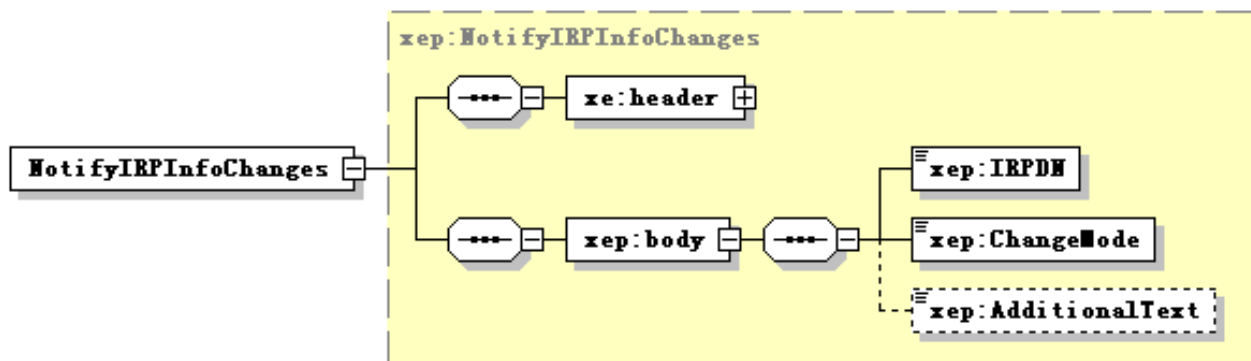

NOTE: The use of XML schema key word “sequence” to support IS-defined set (not sequence) is for the purpose of XML processor efficiency. This shall not imply the use of “sequence” in other technology.

B.3.3 XML Schema “ePIRPNotif.xsd”

```

<?xml version="1.0" encoding="UTF-8"?>
<!--
  3GPP TS 32.366 EPIRP Notification XML Schema
  ePIRPNotif.xsd
-->
<schema xmlns:xep="http://www.3gpp.org/ftp/specs/archive/32_series/32.366#ePIRPNotif"
  xmlns:xe="http://www.3gpp.org/ftp/specs/archive/32_series/32.306#notification"
  xmlns:xn="http://www.3gpp.org/ftp/specs/archive/32_series/32.626#genericNrm"
  xmlns="http://www.w3.org/2001/XMLSchema"
  targetNamespace="http://www.3gpp.org/ftp/specs/archive/32_series/32.366#ePIRPNotif"
  elementFormDefault="qualified" attributeFormDefault="unqualified">
  <import namespace="http://www.3gpp.org/ftp/specs/archive/32_series/32.306#notification"/>
  <import namespace="http://www.3gpp.org/ftp/specs/archive/32_series/32.626#genericNrm"/>
  <simpleType name="ChangeMode">
    <restriction base="string">
      <enumeration value="Register"/>
      <enumeration value="Deregister"/>
      <enumeration value="Modify"/>
    </restriction>
  </simpleType>
  <complexType name="NotifyIRPInfoChanges">
    <complexContent>
      <extension base="xe:Notification">
        <sequence>
          <element name="body">
            <complexType>
              <sequence>
                <element name="IRPDN" type="xn:dn"/>
                <element name="ChangeMode" type="xep:ChangeMode"/>
                <element name="AdditionalText" type="string" minOccurs="0"/>
              </sequence>
            </complexType>
          </element>
        </sequence>
      </extension>
    </complexContent>
  </complexType>
  <element name="NotifyIRPInfoChanges" type="xep:NotifyIRPInfoChanges"/>
</schema>

```

Annex C (normative): SOAP Solution Set

The overall architectural feature of the Entry Point IRP is specified in 3GPP TS 32.362 [6]. This clause specifies features that are specific to the SOAP solution set.

C.1 Architectural Features

C.1.1 Syntax for Distinguished Names and versions

The syntax of a Distinguished Name is defined in 3GPP TS 32.300 [9].

The version of this IRP is represented as a string (see also clause 3.1).

C.1.2 General

The SOAP 1.1 specification [17] and WSDL 1.1 specification [19] are supported.

The SOAP 1.2 specification [20] is supported optionally.

This specification uses "document" style in WSDL file.

This specification uses "literal" encoding style in WSDL file.

The filter language used in the SS is the XPath Language (see W3C XPath 1.0 specification [18]). IRPAgents may throw a FilterComplexityLimit fault when a given filter is too complex.

The Entry Point IRP SOAP SS uses the Notification IRP SOAP SS of 3GPP TS 32.306 [7]. The IRPAgent shall support the push interface model, which means that the IRPAgent sends Entry Point notifications to the IRPManager as soon as new events occur. The IRPManager does not need to check ("pull") for events.

This specification uses a number of namespace prefixes throughout that are listed in Table C.1.2

Table C.1.2: Prefixes and Namespaces used in this specification

PREFIX	NAMESPACE
(no prefix)	http://schemas.xmlsoap.org/wsdl/
soap	http://schemas.xmlsoap.org/wsdl/soap/
entryPointIRPSystem	http://www.3gpp.org/ftp/specs/archive/32_series/32.366#EntryPointIRPSystem
entryPointIRPData	http://www.3gpp.org/ftp/specs/archive/32_series/32.366#EntryPointIRPData
xn	http://www.3gpp.org/ftp/specs/archive/32_series/32.626#genericNm
genericIRPSystem	http://www.3gpp.org/ftp/specs/archive/32_series/32.316#GenericIRPSystem
genericIRPData	http://www.3gpp.org/ftp/specs/archive/32_series/32.316#GenericIRPData
ntfIRPntfSystem	http://www.3gpp.org/ftp/specs/archive/32_series/32.306#NotificationIRPntfSystem

C.2 Mapping

C.2.1 Operation and Notification mapping

The Entry Point IRP IS (3GPP TS 32.362 [6]) defines the operations and their semantics.

Table C.2.1 maps the operations defined in the Entry Point IRP IS to their equivalent types, messages, port type operation, and binding operation in this Solution Set (SS).

Table C.2.1 also maps the notifications of the Entry Point IRP IS, as well as inherited operations.

Table C.2.1 also qualifies if an operation is Mandatory (M) or Optional (O).

Table C.2.1: Mapping from IS Operation to SS Equivalents

IS Operation in 3GPP TS 32.362 [6]	SS: Operation for WSDL port type and WSDL binding	SS: Port of EntryPointIRPService	Qualifier
getIRPOutline	getIRPOutline (note 1)	EntryPointIRPPort	M
getIRPReference	getIRPReference (note 1)	EntryPointIRPPort	M
releaseIRPReference	releaseIRPReference (note 1)	EntryPointIRPPort	M
notifyIRPInfoChanges	notify (note 2)	NotificationIRPNtfPort	M
getIRPVersion (note 3)	See TS 32.316 [15]	GenericIRPPort	M
getOperationProfile (note 3)	See TS 32.316 [15]	GenericIRPPort	O
getNotificationProfile (note 3)	See TS 32.316 [15]	GenericIRPPort	O
NOTE 1: The operation is under the port type <code>entryPointIRPSystem:EntryPointIRPPortType</code> and under the binding <code>entryPointIRPSystem:EntryPointIRPBinding</code> .			
NOTE 2: The IS equivalent maps to an XML definition specified in Annex B, and this being an input parameter to the operation <code>notify</code> under the port type <code>ntfIRPNtfSystem:NotificationIRPNtf</code> and under the binding <code>ntfIRPNtfSystem:NotificationIRPNtf</code> of 3GPP TS 32.306 [7]. This binding is linked to a port of the <code>EntryPointIRPService</code> as indicated in the table above.			
NOTE 3: The IS operation is inherited from the <code>ManagedGenericIRP</code> IOC specified in 3GPP TS 32.312 [4]. This inheritance is by the <code>EPIRP</code> IOC of 3GPP TS 32.362 [6] inheriting from the <code>ManagedGenericIRP</code> IOC. The corresponding binding is linked to a port of the <code>EntryPointIRPService</code> as indicated in the table above.			

C.2.2 Operation parameter mapping

The Entry Point IRP IS (3GPP TS 32.362 [6]) defines semantics of parameters carried in the operations. The tables below show the mapping of these parameters, as per operation, to their equivalents defined in this SS.

C.2.2.1 Operation `getIRPOutline`

C.2.2.1.1 Input parameters

Table C.2.2.1.1: Mapping from IS `getIRPOutline` input parameters to SS equivalents

IS Operation parameter	SS WSDL type sub-element used in corresponding input message under corresponding port type operation as indicated in Table C.2.1	Qualifier
<code>iRPVersion</code>	<code>iRPVersion</code>	M

C.2.2.1.2 Output parameters

Table C.2.2.1.2: Mapping from IS `getIRPOutline` output parameters to SS equivalents

IS Operation parameter	SS WSDL type sub-element used in corresponding output message under corresponding port type operation as indicated in Table C.2.1	Qualifier
supportedIRPList	supportedIRPList	M
status	status	M

C.2.2.1.3 Fault definition

Table C.2.2.1.3: Mapping from IS `getIRPOutline` exceptions to SS equivalents

Assertion name	SS WSDL type enumeration value used in corresponding fault message under corresponding port type operation as indicated in Table C.2.1	Qualifier
invalidIRPVersion	InvalidIRPVersion	M
operationFailed	OperationFailed	M

C.2.2.2 Operation `getIRPReference`

C.2.2.2.1 Input parameters

Table C.2.2.2.1: Mapping from IS `getIRPReference` input parameters to SS equivalents

IS Operation parameter	SS WSDL type sub-element used in corresponding input message under corresponding port type operation as indicated in Table C.2.1	Qualifier
managerIdentifier	managerIdentifier	M
systemDN	systemDN	M
rDN	rDN	M

C.2.2.2.2 Output parameters

Table C.2.2.2.2: Mapping from IS `getIRPReference` output parameters to SS equivalents

IS Operation parameter	SS WSDL type sub-element used in corresponding output message under corresponding port type operation as indicated in Table C.2.1	Qualifier
iRPRReference	iRPRReference	M
status	status	M

C.2.2.2.3 Fault definition

Table C.2.2.2.3: Mapping from IS `getIRPReference` exceptions to SS equivalents

Assertion name	SS WSDL type enumeration value used in corresponding fault message under corresponding port type operation as indicated in Table C.2.1	Qualifier
invalidRequestedParameters	InvalidRequestedParameters	M
operationFailed	OperationFailed	M

C.2.2.3 Operation releaseIRPReference

C.2.2.3.1 Input parameters

Table C.2.2.3.1: Mapping from IS releaseIRPReference input parameters to SS equivalents

IS Operation parameter	SS WSDL type sub-element used in corresponding input message under corresponding port type operation as indicated in Table C.2.1	Qualifier
managerIdentifier	managerIdentifier	M
iRPReference	iRPReference	M

C.2.2.3.2 Output parameters

Table C.2.2.3.2: Mapping from IS releaseIRPReference output parameters to SS equivalents

IS Operation parameter	SS WSDL type sub-element used in corresponding output message under corresponding port type operation as indicated in Table C.2.1	Qualifier
status	status	M

C.2.2.3.3 Fault definition

Table C.2.2.3.3: Mapping from IS releaseIRPReference exceptions to SS equivalents

Assertion name	SS WSDL type enumeration value used in corresponding fault message under corresponding port type operation as indicated in Table C.2.1	Qualifier
unknownIRPReference	UnknownIRPReference	M
operationFailed	OperationFailed	M

C.3 Solution Set definitions

C.3.1 WSDL definition structure

Clause C.3.2 provides a graphical representation of the EP IRP service.
 Clause C.3.3 defines the services which are supported the EP IRP agent.

C.3.2 Graphical Representation

The WSDL structure is depicted in Figure C.3.2 below, depicting port type, binding and service. The port type contains port type operations, which again contains input, output and fault messages. The binding contains binding operations, which have the same name as the port type operations. The binding connects to a port inside the service.

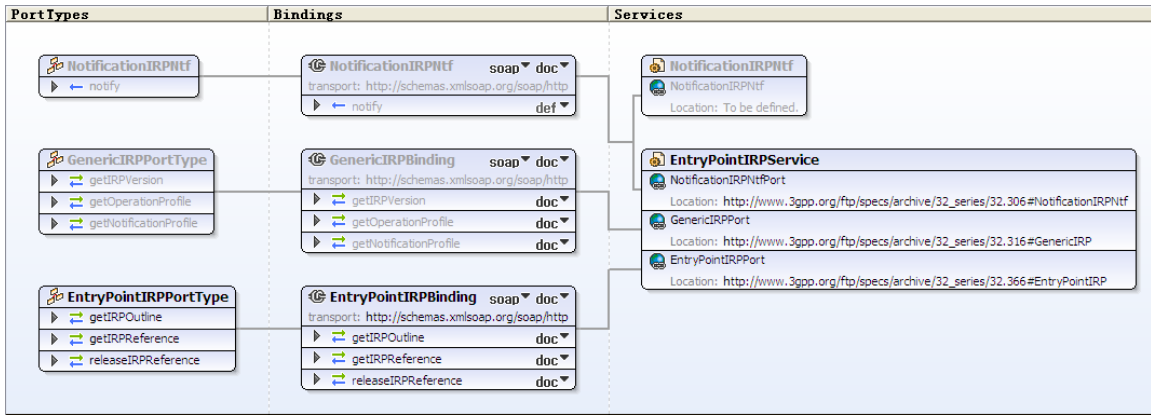

Figure C.3.2: Entry Point IRP SOAP Solution Set WSDL structure

C.3.3 WSDL specification "EntryPointIRPSystem.wsdl"

```

<?xml version="1.0" encoding="UTF-8"?>
<!--
  3GPP TS 32.366 Entry Point IRP SOAP Solution Set
-->
<definitions xmlns="http://schemas.xmlsoap.org/wsdl/"
  xmlns:soap="http://schemas.xmlsoap.org/wsdl/soap/"
  xmlns:entryPointIRPSystem="http://www.3gpp.org/ftp/specs/archive/32_series/32.366#EntryPointIRPSyste
  m"
  xmlns:entryPointIRPData="http://www.3gpp.org/ftp/specs/archive/32_series/32.366#EntryPointIRPData"
  xmlns:xn="http://www.3gpp.org/ftp/specs/archive/32_series/32.626#genericNrm"
  xmlns:genericIRPSystem="http://www.3gpp.org/ftp/specs/archive/32_series/32.316#GenericIRPSystem"
  xmlns:genericIRPData="http://www.3gpp.org/ftp/specs/archive/32_series/32.316#GenericIRPData"
  xmlns:ntfIRPntfSystem="http://www.3gpp.org/ftp/specs/archive/32_series/32.306#NotificationIRPntfSyst
  em" targetNamespace="http://www.3gpp.org/ftp/specs/archive/32_series/32.366#EntryPointIRPSystem">
  <import
  namespace="http://www.3gpp.org/ftp/specs/archive/32_series/32.306#NotificationIRPntfSystem" />
  <import namespace="http://www.3gpp.org/ftp/specs/archive/32_series/32.316#GenericIRPSystem" />
  <types>
    <schema
      targetNamespace="http://www.3gpp.org/ftp/specs/archive/32_series/32.366#EntryPointIRPData"
      xmlns="http://www.w3.org/2001/XMLSchema">
        <import namespace="http://www.3gpp.org/ftp/specs/archive/32_series/32.626#genericNrm"/>
        <import
          namespace="http://www.3gpp.org/ftp/specs/archive/32_series/32.316#GenericIRPData"/>
        <!-- The following types are defined for the Entry Point IRP operations -->
        <simpleType name="OperationStatusTwo">
          <restriction base="string">
            <enumeration value="OperationSucceeded"/>
            <enumeration value="OperationFailed"/>
          </restriction>
        </simpleType>
        <complexType name="IRPManagementScope">
          <sequence>
            <element name="subTreeDN" type="xn:dn" minOccurs="0" maxOccurs="unbounded"/>
          </sequence>
        </complexType>
        <complexType name="IRPElement">
          <sequence>
            <element name="rDN" type="xn:dn"/>
            <element name="iRPVersionSet" type="genericIRPData:VersionNumberSetType"/>
            <element name="iRPManagementScope" type="entryPointIRPData:IRPManagementScope"
              minOccurs="0"/>
          </sequence>
        </complexType>
        <complexType name="IRPList">
          <sequence>
            <element name="iRPElement" type="entryPointIRPData:IRPElement"
              maxOccurs="unbounded"/>
          </sequence>
        </complexType>
        <complexType name="SupportedIRP">
          <sequence>
            <element ref="xn:systemDN"/>
            <element name="iRPList" type="entryPointIRPData:IRPList"/>
          </sequence>
        </complexType>
        <complexType name="SupportedIRPList">
          <sequence>
            <element name="supportedIRP" type="entryPointIRPData:SupportedIRP"
              maxOccurs="unbounded"/>
          </sequence>
        </complexType>
        <!-- getIRPOutline Request-->
        <element name="getIRPOutline">
          <complexType>
            <sequence>
              <element name="iRPVersion" type="genericIRPData:VersionNumberType"/>
            </sequence>
          </complexType>
        </element>
        <!-- getIRPOutline Response -->
        <element name="getIRPOutlineResponse">
          <complexType>
            <sequence>

```

```

        <element name="supportedIRPList" type="entryPointIRPData:SupportedIRPList"/>
        <element name="status" type="entryPointIRPData:OperationStatusTwo"/>
    </sequence>
</complexType>
</element>
<!-- getIRPOutline Fault -->
<element name="getIRPOutlineFault">
    <simpleType>
        <restriction base="string">
            <enumeration value="InvalidIRPVersion"/>
            <enumeration value="OperationFailed"/>
        </restriction>
    </simpleType>
</element>
<!-- getIRPReference Request -->
<element name="getIRPReference">
    <complexType>
        <sequence>
            <element name="managerIdentifier" type="xn:dn"/>
            <element ref="xn:systemDN"/>
            <element name="rDN" type="xn:dn"/>
        </sequence>
    </complexType>
</element>
<!-- getIRPReference Response -->
<element name="getIRPReferenceResponse">
    <complexType>
        <sequence>
            <element name="iRPReference" type="xn:dn"/>
            <element name="status" type="entryPointIRPData:OperationStatusTwo"/>
        </sequence>
    </complexType>
</element>
<!-- getIRPReference Fault -->
<element name="getIRPReferenceFault">
    <simpleType>
        <restriction base="string">
            <enumeration value="InvalidRequestedParameters"/>
            <enumeration value="OperationFailed"/>
        </restriction>
    </simpleType>
</element>
<!-- releaseIRPReference Request -->
<element name="releaseIRPReference ">
    <complexType>
        <sequence>
            <element name="managerIdentifier" type="xn:dn"/>
            <element name="iRPReference" type="xn:dn"/>
        </sequence>
    </complexType>
</element>
<!-- releaseIRPReference Response -->
<element name="releaseIRPReferenceResponse">
    <complexType>
        <sequence>
            <element name="status" type="entryPointIRPData:OperationStatusTwo"/>
        </sequence>
    </complexType>
</element>
<!-- releaseIRPReference Fault -->
<element name="releaseIRPReferenceFault">
    <simpleType>
        <restriction base="string">
            <enumeration value="UnknownIRPReference"/>
            <enumeration value="OperationFailed"/>
        </restriction>
    </simpleType>
</element>
</schema>
</types>
<message name="getIRPOutline">
    <part name="parameter" element="entryPointIRPData:getIRPOutline"/>
</message>
<message name="getIRPOutlineResponse">
    <part name="parameter" element="entryPointIRPData:getIRPOutlineResponse"/>
</message>
<message name="getIRPOutlineFault">
    <part name="parameter" element="entryPointIRPData:getIRPOutlineFault"/>

```

```

</message>
<message name="getIRPReference">
  <part name="parameter" element="entryPointIRPData:getIRPReference"/>
</message>
<message name="getIRPReferenceResponse">
  <part name="parameter" element="entryPointIRPData:getIRPReferenceResponse"/>
</message>
<message name="getIRPReferenceFault">
  <part name="parameter" element="entryPointIRPData:getIRPReferenceFault"/>
</message>
<message name="releaseIRPReference">
  <part name="parameter" element="entryPointIRPData:releaseIRPReference"/>
</message>
<message name="releaseIRPReferenceResponse">
  <part name="parameter" element="entryPointIRPData:releaseIRPReferenceResponse"/>
</message>
<message name="releaseIRPReferenceFault">
  <part name="parameter" element="entryPointIRPData:releaseIRPReferenceFault"/>
</message>
<portType name="EntryPointIRPPortType">
  <operation name="getIRPOutline">
    <input message="entryPointIRPSystem:getIRPOutline"/>
    <output message="entryPointIRPSystem:getIRPOutlineResponse"/>
    <fault name="getIRPOutlineFault" message="entryPointIRPSystem:getIRPOutlineFault"/>
  </operation>
  <operation name="getIRPReference">
    <input message="entryPointIRPSystem:getIRPReference"/>
    <output message="entryPointIRPSystem:getIRPReferenceResponse"/>
    <fault name="getIRPReferenceFault" message="entryPointIRPSystem:getIRPReferenceFault"/>
  </operation>
  <operation name="releaseIRPReference">
    <input message="entryPointIRPSystem:releaseIRPReference"/>
    <output message="entryPointIRPSystem:releaseIRPReferenceResponse"/>
    <fault name="releaseIRPReferenceFault"
message="entryPointIRPSystem:releaseIRPReferenceFault"/>
  </operation>
</portType>
<binding name="EntryPointIRPBinding" type="entryPointIRPSystem:EntryPointIRPPortType">
  <soap:binding style="document" transport="http://schemas.xmlsoap.org/soap/http"/>
  <operation name="getIRPOutline">
    <soap:operation
soapAction="http://www.3gpp.org/ftp/specs/archive/32_series/32.366#getIRPOutline" style="document"/>
    <input>
      <soap:body use="literal"/>
    </input>
    <output>
      <soap:body use="literal"/>
    </output>
    <fault name="getIRPOutlineFault">
      <soap:fault name="getIRPOutlineFault" use="literal"/>
    </fault>
  </operation>
  <operation name="getIRPReference">
    <soap:operation
soapAction="http://www.3gpp.org/ftp/specs/archive/32_series/32.366#getIRPReference"
style="document"/>
    <input>
      <soap:body use="literal"/>
    </input>
    <output>
      <soap:body use="literal"/>
    </output>
    <fault name="getIRPReferenceFault">
      <soap:fault name="getIRPReferenceFault" use="literal"/>
    </fault>
  </operation>
  <operation name="releaseIRPReference">
    <soap:operation
soapAction="http://www.3gpp.org/ftp/specs/archive/32_series/32.366#releaseIRPReference"
style="document"/>
    <input>
      <soap:body use="literal"/>
    </input>
    <output>
      <soap:body use="literal"/>
    </output>
    <fault name="releaseIRPReferenceFault">
      <soap:fault name="releaseIRPReferenceFault" use="literal"/>
    </fault>
  </operation>

```

```
        </fault>
      </operation>
    </binding>
    <service name="EntryPointIRPService">
      <port name="EntryPointIRPPort" binding="entryPointIRPSystem:EntryPointIRPBinding">
        <soap:address
location="http://www.3gpp.org/ftp/specs/archive/32_series/32.366#EntryPointIRP"/>
        </port>
      <port name="GenericIRPPort" binding="genericIRPSystem:GenericIRPBinding">
        <soap:address
location="http://www.3gpp.org/ftp/specs/archive/32_series/32.316#GenericIRP"/>
        </port>
      <port name="NotificationIRPNtfPort" binding="ntfIRPNtfSystem:NotificationIRENtf">
        <soap:address
location="http://www.3gpp.org/ftp/specs/archive/32_series/32.306#NotificationIRPNtf"/>
        </port>
    </service>
</definitions>
```

Annex D (informative): Change history

Change history							
Date	TSG #	TSG Doc.	CR	Rev	Subject/Comment	Old	New
2010-09	SA#49	SP-100510	--	--	Presentation to SA for Information and Approval	---	1.0.0
2010-10	--	--	--	--	Publication	1.0.0	10.0.0
2012-09	--	--	--	--	Automatic upgrade from previous Release version 10.0.0	10.0.0	11.0.0