

# 3GPP TS 32.356 V11.0.0 (2012-09)

---

*Technical Specification*

**3rd Generation Partnership Project;  
Technical Specification Group Services and System Aspects;  
Telecommunication management;  
Communication Surveillance (CS)  
Integration Reference Point (IRP);  
Solution Set (SS) definitions  
(Release 11)**

---



The present document has been developed within the 3<sup>rd</sup> Generation Partnership Project (3GPP<sup>TM</sup>) and may be further elaborated for the purposes of 3GPP. The present document has not been subject to any approval process by the 3GPP Organizational Partners and shall not be implemented. This Specification is provided for future development work within 3GPP only. The Organizational Partners accept no liability for any use of this Specification. Specifications and reports for implementation of the 3GPP<sup>TM</sup> system should be obtained via the 3GPP Organizational Partners' Publications Offices.

---

---

**Keywords**

management, communication surveillance,  
CORBA, XML, SOAP

**3GPP**

---

**Postal address**

---

**3GPP support office address**

650 Route des Lucioles - Sophia Antipolis  
Valbonne - FRANCE  
Tel.: +33 4 92 94 42 00 Fax: +33 4 93 65 47 16

---

**Internet**

<http://www.3gpp.org>

---

**Copyright Notification**

---

No part may be reproduced except as authorized by written permission.  
The copyright and the foregoing restriction extend to reproduction in all media.

© 2012, 3GPP Organizational Partners (ARIB, ATIS, CCSA, ETSI, TTA, TTC).  
All rights reserved.

UMTS™ is a Trade Mark of ETSI registered for the benefit of its members  
3GPP™ is a Trade Mark of ETSI registered for the benefit of its Members and of the 3GPP Organizational Partners  
LTE™ is a Trade Mark of ETSI currently being registered for the benefit of its Members and of the 3GPP Organizational Partners  
GSM® and the GSM logo are registered and owned by the GSM Association

# Contents

Foreword .....	5
Introduction .....	5
1 Scope .....	6
2 References.....	6
3 Definitions and abbreviations .....	7
3.1 Definitions .....	7
3.2 Abbreviations.....	7
4 Solution Set definitions .....	7
<b>Annex A (normative): CORBA Solution Set.....</b>	<b>8</b>
A.1 Architectural Features .....	8
A.1.1 Syntax for Distinguished Names and Versions.....	8
A.1.2 Notifications .....	8
A.2 Mapping.....	8
A.2.1 Operation and Notification mapping .....	8
A.2.2 Operation parameter mapping .....	8
A.2.3 Notification parameter mapping .....	9
A.3 CSIRPNotification Interface .....	12
A.3.1 Method <code>push (M)</code> .....	12
A.4 Solution Set definitions .....	12
A.4.1 IDL definition structure.....	12
A.4.2 IDL specification “CSIRPConstDefs.idl” .....	13
A.4.3 IDL specification “CSIRPSystem.idl” .....	14
A.4.4 IDL specification “CSIRPNotifications.idl” .....	16
<b>Annex B (normative): XML definitions.....</b>	<b>17</b>
B.1 Architectural features .....	17
B.1.1 Syntax for Distinguished Names .....	17
B.2 Mapping .....	17
B.3 Solution Set definitions .....	17
B.3.1 XML definition structure .....	17
B.3.2 Graphical Representation.....	17
B.3.3 XML Schema “cSIRPNotif.xsd” .....	18
B.3.4 XML Schema “cSIRPIOC.xsd” .....	19
<b>Annex C (normative): SOAP Solution Set.....</b>	<b>20</b>
C.1 Architectural Features .....	20
C.1.1 Syntax for Distinguished Names and versions.....	20
C.1.2 General .....	20
C.2 Mapping.....	21
C.2.1 Operation and Notification mapping .....	21
C.2.2 Operation parameter mapping .....	21
C.2.3 Notification parameter mapping .....	21
C.3 Solution Set definitions .....	21
C.3.1 WSDL definition structure.....	21
C.3.2 Graphical Representation.....	22
C.3.3 WSDL specification “CSIRPSystem.wsdl” .....	23

**Annex D (informative):**      **Change history.....27**

---

## Foreword

This Technical Specification has been produced by the 3<sup>rd</sup> Generation Partnership Project (3GPP).

The contents of the present document are subject to continuing work within the TSG and may change following formal TSG approval. Should the TSG modify the contents of the present document, it will be re-released by the TSG with an identifying change of release date and an increase in version number as follows:

Version x.y.z

where:

- x the first digit:
  - 1 presented to TSG for information;
  - 2 presented to TSG for approval;
  - 3 or greater indicates TSG approved document under change control.
- y the second digit is incremented for all changes of substance, i.e. technical enhancements, corrections, updates, etc.
- z the third digit is incremented when editorial only changes have been incorporated in the document.

---

## Introduction

The present document is part of a TS-family covering the 3<sup>rd</sup> Generation Partnership Project: Technical Specification Group Services and System Aspects; Telecommunication management; as identified below:

- TS 32.351: "Communication Surveillance (CS) Integration Reference Point (IRP): Requirements";
- TS 32.352: "Communication Surveillance (CS) Integration Reference Point (IRP): Information Service (IS)";
- TS 32.356: "Communication Surveillance (CS) Integration Reference Point (IRP): Solution Set (SS) definitions"**

The present document is part of a set of technical specifications defining the telecommunication management (TM) of 3G systems. The TM principles are described in 3GPP TS 32.101 [1]. The TM architecture is described in 3GPP TS 32.102 [2]. The other specifications define the interface (Itf-N) between the managing system (manager), which is in general the network manager (NM) and the managed system (agent), which is either an element manager (EM) or the managed NE itself. The Itf-N is composed of a number of integration reference points (IRPs) defining the information in the agent that is visible for the manager, the operations that the manager may perform on this information and the notifications that are sent from the agent to the manager. CS (Communication Surveillance) IRP is one of these IRPs with special function.

To ensure the availability and reliability of the management, an automatic surveillance of the communication between NM and the managed system are required. CSIRP is defined as a capability to achieve this goal.

---

## 1 Scope

The present document specifies the Solution Set definitions for the IRP whose semantics is specified in TS 32.352 [6] Communication Surveillance IRP: Information Service..

This Solution Set definitions specification is related to 3GPP TS 32.352 V11.0.X.

---

## 2 References

The following documents contain provisions which, through reference in this text, constitute provisions of the present document.

- References are either specific (identified by date of publication, edition number, version number, etc.) or non-specific.
- For a specific reference, subsequent revisions do not apply.
- For a non-specific reference, the latest version applies. In the case of a reference to a 3GPP document (including a GSM document), a non-specific reference implicitly refers to the latest version of that document *in the same Release as the present document*.

- [1] 3GPP TS 32.101: "Telecommunication management; Principles and high level requirements".
- [2] 3GPP TS 32.102: "Telecommunication management; Architecture".
- [3] 3GPP TS 32.351: "Telecommunication management; Communication Surveillance (CS) Integration Reference Point (IRP): Requirements".
- [4] 3GPP TS 32.312: "Telecommunication management; Generic Integration Reference Point (IRP): Information Service (IS)".
- [5] 3GPP TS 32.311: "Telecommunication management; Generic Integration Reference Point (IRP): Requirements".
- [6] 3GPP TS 32.352: "Telecommunication management; Communication Surveillance (CS) Integration Reference Point (IRP): Information Service (IS)".
- [7] 3GPP TS 32.306: "Telecommunication management; Configuration Management (CM); Notification Integration Reference Point (IRP): Solution Set (SS) definitions".
- [8] OMG TC Document telecom/98-11-01: "OMG Notification Service".  
<http://www.omg.org/technology/documents/>
- [9] 3GPP TS 32.300: "Telecommunication management; Configuration Management (CM); Name convention for Managed Objects".
- [10] 3GPP TS 32.336: "Telecommunication management; Notification Log (NL) Integration Reference Point (IRP): Solution Set (SS) definitions".
- [11] 3GPP TS 32.331: "Telecommunication management; Notification Log (NL) Integration Reference Point (IRP): Requirements".
- [12] 3GPP TR 21.905: "Vocabulary for 3GPP Specifications".
- [13] 3GPP TS 32.150: "Telecommunication management; Integration Reference Point (IRP) Concept and definitions".
- [14] W3C SOAP 1.1 specification (<http://www.w3.org/TR/2000/NOTE-SOAP-20000508/>)
- [15] W3C XPath 1.0 specification (<http://www.w3.org/TR/1999/REC-xpath-19991116>)
- [16] W3C WSDL 1.1 specification (<http://www.w3.org/TR/2001/NOTE-wsdl-20010315>)

[17] W3C SOAP 1.2 specification (<http://www.w3.org/TR/soap12-part1/>)

---

## 3 Definitions and abbreviations

### 3.1 Definitions

For the purposes of the present document, the terms and definitions given in TR 21.905 [12], 3GPP TS 32.101 [1], 3GPP TS 32.102 [2], 3GPP TS 32.150 [13], 3GPP TS 32.351 [3], 3GPP TS 32.352 [6] and 3GPP TS 32.331 [11]. A term defined in the present document takes precedence over the definition of the same term, if any, in TR 21.905 [12]. And the following apply:

**IRP document version number string (or "IRPVersion"):** see 3GPP TS 32.311 [5].

### 3.2 Abbreviations

For the purposes of the present document, the following abbreviations apply:

CORBA	Common Object Request Broker Architecture
CS	Communication Surveillance
CSIRP	Communication Surveillance IRP
DN	Distinguished Name
EM	Element Manager
IRP	Integration Reference Point
IOC	Information Object Class
IS	Information Service
NE	Network Element
NL	Notification Log
NM	Network Manager
NRM	Network Resource Model
SS	Solution Set
UML	Unified Modelling Language
XML	eXtensible Markup Language

---

## 4 Solution Set definitions

This specification defines the following 3GPP CS IRP Solution Set definitions:

- 3GPP CS IRP CORBA SS (Annex A)
- 3GPP CS IRP XML definitions (Annex B)
- 3GPP CS IRP SOAP Solution Set (Annex C)

## Annex A (normative): CORBA Solution Set

This annex contains the CORBA Solution Set for the IRP whose semantics is specified in CS IRP: Information Service (TS 32.352 [6]).

### A.1 Architectural Features

The overall architectural feature of CS IRP is specified in 3GPP TS 32.352 [6].

This clause specifies features that are specific to the CORBA SS.

#### A.1.1 Syntax for Distinguished Names and Versions

The syntax of a Distinguished Name is defined in 3GPP TS 32.300 [9].

The version of this IRP is represented as a string (see also clause 3 for versions).

#### A.1.2 Notifications

Notifications are sent according to the Notification IRP: CORBA SS (see 3GPP TS 32.306 [7]).

The contents of the CS IRP notifications are defined in the present document.

### A.2 Mapping

#### A.2.1 Operation and Notification mapping

CSIRP: IS 3GPP TS 32.352 [6] defines semantics of operation and notification visible across the CSIRP. Table A.2.1 indicates mapping of these operations and notifications to their equivalents defined in this SS.

**Table A.2.1: Mapping from IS Operations and Notification to SS equivalents**

IS Operations/ notification TS 32.352 [6]	SS Method	Qualifier
getHeartbeatPeriod	get_heartbeat_period	M
setHeartbeatPeriod	set_heartbeat_period	O
triggerHeartbeat	trigger_heartbeat	M
notifyHeartbeat	push_structured_event (See clause A.3.1)	M
getIRPVersion (see note)	get_cs_irp_versions	M
getOperationProfile (see note)	get_cs_irp_operations_profile	O
getNotificationProfile (see note)	get_cs_irp_notification_profile	O
NOTE: This operation is of ManagedGenericIRP IOC specified in 3GPP TS 32.312 [4]. The CSIRP IOC of TS 32.352 [6] inherits from it.		

#### A.2.2 Operation parameter mapping

The CSIRP: IS 3GPP TS 32.352 [6] defines semantics of parameters carried in operations across the CSIRP. The following tables indicate the mapping of these parameters, as per operation, to their equivalents defined in this SS.



**Table A.2.2.1: Mapping from IS `getHeartbeatPeriod` parameters to SS equivalents**

IS Operation parameter	SS Method parameter	Qualifier
heartbeatPeriod	CSIRPCConstDefs::HeartbeatPeriod heartbeat_period	M
status	Return value of type CSIRPCConstDefs::Result Exception: GetHeartbeatPeriod	M

**Table A.2.2.2: Mapping from IS `setHeartbeatPeriod` parameters to SS equivalents**

IS Operation parameter	SS Method parameter	Qualifier
heartbeatPeriod	CSIRPCConstDefs::HeartbeatPeriod heartbeat_period	M
status	Return value of type CSIRPCConstDefs::Result Exception: SetHeartbeatPeriod, InvalidHeartbeatPeriod, ConflictingHeartbeatPeriod, ManagedGenericIRPSystem::ValueNotSupported, ManagedGenericIRPSystem::OperationNotSupported	M

**Table A.2.2.3: Mapping from IS `triggerHeartbeat` parameters to SS equivalents**

IS Operation parameter	SS Method parameter	Qualifier
managerIdentifier	CSIRPCConstDefs::ManagerIdentifier manager_identifier	M
status	Return value of type CSIRPCConstDefs::Result Exception: TriggerHeartbeat, InvalidManagerIdentifier	M
NOTE: For CORBA SS, the managerIdentifier of triggerHeartbeat operation shall be mapped to managerReference which is same as what IRPManager used to subscribe notifications [7].		

**Table A.2.2.4: Mapping from IS `getIRPVersion` parameters to SS equivalents**

IS Operation parameter	SS Method parameter	Qualifier
versionNumberSet	Return value of type ManagedGenericIRPConstDefs::VersionNumberSet	M
status	Exception: GetCSIRPVersions	M

**Table A.2.2.5: Mapping from IS `getOperationProfile` parameters to SS equivalents**

IS Operation parameter	SS Method parameter	Qualifier
iRPVersion	ManagedGenericIRPConstDefs::VersionNumber irp_version	M
operationNameProfile, operationParameterProfile	Return value of type ManagedGenericIRPConstDefs::MethodList	M
status	Exception: GetCSIRPOperationsProfile, ManagedGenericIRPSystem::OperationNotSupported, ManagedGenericIRPSystem::InvalidParameter	M

**Table A.2.2.6: Mapping from IS `getNotificationProfile` parameters to SS equivalents**

IS Operation parameter	SS Method parameter	Qualifier
iRPVersion	ManagedGenericIRPConstDefs::VersionNumber irp_version	M
notificationNameProfile, notificationParameterProfile	Return value of type ManagedGenericIRPConstDefs::MethodList	M
status	Exception: GetCSIRPNotificationProfile, ManagedGenericIRPSystem::OperationNotSupported, ManagedGenericIRPSystem::InvalidParameter	M

## A.2.3 Notification parameter mapping

The semantics of parameters carried in notifications are defined in CSIRP IS (3GPP TS 32.352 [6]).

Table A.2.3 indicates the mapping of these parameters to their OMG CORBA Structured Event [8] equivalents.

The composition of OMG Structured Event, as defined in [8] is:

```
Header
  Fixed Header
    domain_name
    type_name
    event_name
  Variable Header
Body
  filterable_body_fields
  remaining_body
```

Table A.2.3 lists in the second column all OMG Structured Event attributes. The first column identifies the notification parameters defined in CSIRP IS (3GPP TS 32.352 [6]).

Table A.2.3: Mapping for notifyHeartBeat

IS Parameters	OMG CORBA Structured Event attribute	Qualifier	Comment
There is no corresponding IS attribute.	domain_name	M	It carries the IRP document version number string. See clause 3.1. It indicates the syntax and semantics of the Structured Event as defined by the present document.
notificationType	type_name	M	This is the ET_HEARTBEAT of module of CSIRPCConstDefs.
There is no corresponding IS attribute	event_name	M	It carries no information.
There is no corresponding IS attribute.	Variable Header		
objectClass, objectInstance	One NV pair of filterable_body_fields	M	NV stands for name-value pair. Order arrangement of NV pairs is not significant. The name of NV-pair is always encoded in string.  Name of this NV pair is the MANAGED_OBJECT_INSTANCE of interface AttributeNameValue of module NotificationIRPCConstDefs.  Value of NV pair is a string. See corresponding table in Notification IRP: CORBA SS of [7].
notificationId	One NV pair of remaining_body	M	Name of NV pair is the NOTIFICATION_ID of interface AttributeNameValue of module NotificationIRPCConstDefs.  Value of NV pair is a long. See corresponding table in Notification IRP: CORBA SS of [7].
eventTime	One NV pair of filterable_body_fields	M	Name of NV pair is the EVENT_TIME of interface AttributeNameValue of module NotificationIRPCConstDefs.  Value of NV pair is IRPTime. See corresponding table in Notification IRP: CORBA SS of [7].
systemDN	One NV pair of filterable_body_fields	M	Name of NV pair is the SYSTEM_DN of interface AttributeNameValue of module NotificationIRPCConstDefs.  Value of NV pair is a string. See corresponding table in Notification IRP: CORBA SS of [7].
heartbeatPeriod	One NV pair of remaining_body	M	Name of NV pair is the HEARTBEAT_PERIOD of interface NotifyHeartbeat of module CSIRPNotifications.  Value of NV pair is a CSIRPCConstDefs::HeartbeatPeriod.
triggerFlag	One NV pair of remaining_body	M	Name of NV pair is the TRIGGER_FLAG of interface NotifyHeartbeat of module CSIRPNotifications.  Value of NV pair is a CSIRPCConstDefs::TriggerFlag.
locator	One NV pair of remaining_body	M	Name of NV pair is the CHANNEL_ID of interface NotifyHeartbeat of module CSIRPNotifications.  Value of NV pair is a CSIRPCConstDefs::ChannelId.  This parameter shall be mapped to an identifier of channel. For definition of channel, see OMG Notification Service [8].  The CHANNEL_ID carry the same meaning but may or may not carry the same value used by OMG defined Channel ID.
managerIdentifier	One NV pair of remaining_body	M	Name of NV pair is the MANAGER_IDENTIFIER of interface NotifyHeartbeat of module CSIRPNotifications.  Value of NV pair is a CSIRPCConstDefs::ManagerIdentifier.

---

## A.3 CSIRPNotification Interface

OMG CORBA Notification push operation is used to realise the notification of CSIRPNotifications. All the notifications in this interface are implemented using this `push_structured_event` method.

### A.3.1 Method `push` (M)

```
module CosNotifyComm {
    ...
    Interface SequencePushConsumer : NotifyPublish {
        void push_structured_events(
            in CosNotification::EventBatch notifications)
        raises ( CosEventComm::Disconnected );
        ...
    }; // SequencePushConsumer
    ...
}; // CosNotifyComm
```

NOTE 1: The `push_structured_events` method takes an input parameter of type `EventBatch` as defined in the `OMG CosNotification` module (OMG Notification Service [8]). This data type is the same as a sequence of Structured Events. Upon invocation, this parameter will contain a sequence of Structured Events being delivered to `IRPManager` by `IRPAgent` to which it is connected.

NOTE 2: The maximum number of events that will be transmitted within a single invocation of this operation is controlled by `IRPAgent` wide configuration parameter.

NOTE 3: The amount of time the supplier (`IRPAgent`) of a sequence of Structured Events will accumulate individual events into the sequence before invoking this operation is controlled by `IRPAgent` wide configuration parameter as well.

NOTE 4: `IRPAgent` may push `EventBatch` with only one Structured Event.

---

## A.4 Solution Set definitions

### A.4.1 IDL definition structure

Clause A.4.2 defines the constants and types used by the CS IRP.

Clause A.4.3 defines the operations which are performed by the CS IRP agent.

Clause A.4.4 defines the notifications which are performed by the CS IRP agent.

## A.4.2 IDL specification "CSIRPConstDefs.idl"

```
//File: CSIRPConstDefs.idl
#ifndef _CS_IRP_CONST_DEFS_IDL_
#define _CS_IRP_CONST_DEFS_IDL_

// This statement must appear after all include statements
#pragma prefix "3gppsa5.org"

/* ## Module: CSIRPConstDefs
This module contains commonly used definitions for CSIRP.
=====
*/
module CSIRPConstDefs
{
    typedef unsigned short HeartbeatPeriod;

    /*
    If notifyHeartbeat is triggered by NM positively by invoking
    triggerHeartbeat operation, the value of this parameter shall be IRPManager,
    otherwise, it shall be IRPAgent.
    */
    enum TriggerFlag {IRPManager, IRPAgent};

    typedef string ManagerIdentifier;

    typedef string ChannelId;

    /*
    It specifies whether the operation is success or failed.
    */
    enum Result {SUCCESS, FAILURE};

    /**
    * This block identifies attributes which are included as part of the
    * CommunicationSurveillanceIRP. These attribute values should not
    * clash with those defined for the attributes of notification
    * header (see IDL of Notification IRP).
    */
    interface AttributeNameValue
    {
        const string HEARTBEAT_PERIOD = "HEARTBEAT_PERIOD";
        const string CHANNEL_ID = "CHANNEL_ID";
        const string TRIGGER_FLAG = "TRIGGER_FLAG";
        const string MANAGER_IDENTIFIER = "MANAGER_IDENTIFIER";
    };
};

#endif// _CS_IRP_CONST_DEFS_IDL_
```

### A.4.3 IDL specification "CSIRPSystem.idl"

```
//File: CSIRPSystem.idl
#ifndef _CS_IRP_SYSEEM_IDL_
#define _CS_IRP_SYSEEM_IDL_

#include <ManagedGenericIRPSystem.idl>
#include <ManagedGenericIRPConstDefs.idl>
#include <CSIRPConstDefs.idl>

// This statement must appear after all include statements
#pragma prefix "3gppsa5.org"

/* ## Module: CSIRPSystem
This module implements capabilities of CSIRP.
=====
*/
module CSIRPSystem
{
    /**
     * The InvalidHeartbeatPeriod exception is used when the period
     * value to be set by IRPManager is not a reasonable in IRPAgent's
     * implementation. A very short period may cause IRPAgent to
     * send many heartbeat notification in a short time, which may
     * decrease the performance of IRPAgent. To prevent this,
     * IRPAgent may set the lower limit period in its system
     * implementation. When the period to be set is shorter the
     * lower limit period, IRPAgent may throw this exception
     * and reject to set the period to new value.
     * Note: set the period to zero must be allowed. The behaviour of
     * setting period to zero pls see definition for Period.
     */
    exception InvalidHeartbeatPeriod
    {
        unsigned short period_lower_limit;
        string reason;
    };

    exception InvalidManagerIdentifier { string reason; };
    exception ConflictingHeartbeatPeriod { string reason; };

    /**
     * System fails to complete the operation. System can provide reason
     * to qualify the exception. The semantics carried in reason
     * is outside the scope of this IRP.
     */
    exception GetHeartbeatPeriod { string reason; };
    exception SetHeartbeatPeriod { string reason; };
    exception TriggerHeartbeat { string reason; };
    exception GetCSIRPVersions { string reason; };
    exception GetCSIRPOperationsProfile { string reason; };
    exception GetCSIRPNotificationProfile { string reason; };

    interface CSIRP
    {
        /**
         * IRPManager invokes this operation to obtain the current
         * heartbeat period.
         */
        CSIRPConstDefs::Result get_heartbeat_period(
            out CSIRPConstDefs::HeartbeatPeriod heartbeat_period
        )
        raises (GetHeartbeatPeriod);

        /**
         * IRPManager invokes this operation to set the heartbeatPeriod.
         * If the heartbeatPeriod is modified by one IRPManager, a
         * notifyHeartbeat notification should be emitted
         * immediately to all the subscribed IRPManagers to indicate
         * the new heartbeatPeriod. If the heartbeatPeriod is set to
         * zero, one notifyHeartbeat notification will be
         * emitted immediately and no more
         * notifications unless the heartbeatPeriod is modified again.
         */
        CSIRPConstDefs::Result set_heartbeat_period(

```

```
        in CSIRPConstDefs::HeartbeatPeriod heartbeat_period
    )
    raises (SetHeartbeatPeriod,
           ConflictingHeartbeatPeriod,
           InvalidHeartbeatPeriod,
           ManagedGenericIRPSystem::ValueNotSupported,
           ManagedGenericIRPSystem::OperationNotSupported);

    /*
    * IRPManager invoke this operation to trigger ET_HEARTBEAT
    * notification positively.
    */
    CSIRPConstDefs::Result trigger_heartbeat(
        in CSIRPConstDefs::ManagerIdentifier manager_identifier
    )
    raises (TriggerHeartbeat, InvalidManagerIdentifier);

    /**
    * Return the list of all supported CSIRP versions.
    */
    ManagedGenericIRPConstDefs::VersionNumberSet get_cs_irp_versions (
    )
    raises (GetCSIRPVersions);

    /**
    * Return the list of all supported operations and their supported
    * parameters for a specific CSIRP version.
    */
    ManagedGenericIRPConstDefs::MethodList get_cs_irp_operations_profile (
        in ManagedGenericIRPConstDefs::VersionNumber irp_version
    )
    raises (GetCSIRPOperationsProfile,
           ManagedGenericIRPSystem::OperationNotSupported,
           ManagedGenericIRPSystem::InvalidParameter);

    /**
    * Return the list of all supported notifications and their supported
    * parameters for a specific CSIRP version.
    */
    ManagedGenericIRPConstDefs::MethodList get_cs_irp_notification_profile (
        in ManagedGenericIRPConstDefs::VersionNumber irp_version
    )
    raises (GetCSIRPNotificationProfile,
           ManagedGenericIRPSystem::OperationNotSupported,
           ManagedGenericIRPSystem::InvalidParameter);
};

};

#endif // _CS_IRP_SYSTEM_IDL_
```

## A.4.4 IDL specification “CSIRPNotifications.idl”

```

//File: CSIRPNotifications.idl
#ifndef _CS_IRP_NOTIFICATIONS_IDL_
#define _CS_IRP_NOTIFICATIONS_IDL_

#include <CSIRPConstDefs.idl>
#include <NotificationIRPNotifications.idl>

// This statement must appear after all include statements
#pragma prefix "3gppsa5.org"

/* ## Module: CSIRPNotifications
This module contains the specification of all notifications of CS IRPAgent.
=====
*/
module CSIRPNotifications
{
    /**
    * Constant definitions for the FileReady notification
    */
    interface NotifyHeartbeat: NotificationIRPNotifications::Notify
    {
        const string EVENT_TYPE = "notifyHeartbeat";

        /**
        * This constant defines the name of the period property,
        * which is transported in the filterable_body fields.
        * The data type for the value of this property
        * is CSIRPConstDefs::HeartbeatPeriod.
        */
        const string HEARTBEAT_PERIOD = CSIRPConstDefs::AttributeNameValue::HEARTBEAT_PERIOD;

        /**
        * This constant defines the name of the
        * channelId property,
        * which is transported in the filterable_body
        * fields.
        * The data type for the value of this property
        * is CSIRPConstDefs::ChannelId.
        */
        const string CHANNEL_ID = CSIRPConstDefs::AttributeNameValue::CHANNEL_ID;

        /**
        * This constant defines the name of the
        * triggerFlag property,
        * which is transported in the filterable_body
        * fields.
        * The data type for the value of this property
        * is CSIRPConstDefs::TriggerFlag.
        */
        const string TRIGGER_FLAG = CSIRPConstDefs::AttributeNameValue::TRIGGER_FLAG;

        /**
        * This constant defines the name of the
        * managerIdentifier property,
        * which is transported in the filterable_body
        * fields.
        * The data type for the value of this property
        * is CSIRPConstDefs::ManagerIdentifier.
        */
        const string MANAGER_IDENTIFIER = CSIRPConstDefs::AttributeNameValue::MANAGER_IDENTIFIER;
    };
};

#endif // _CS_IRP_NOTIFICATIONS_IDL_

```



## Annex B (normative): XML definitions

The annex specifies the XML Definitions for the CS Integration Reference Point (IRP) as it applies to Itf-N, in accordance with CS IRP IS definitions [6], for usage with the Notification Log IRP XML Definitions [10].

### B.1 Architectural features

The overall architectural feature of CS IRP is specified in 3GPP TS 32.352 [6].

This clause specifies features that are specific to the XML Schema definitions.

#### B.1.1 Syntax for Distinguished Names

The syntax of a Distinguished Name is defined in 3GPP TS 32.300 [9].

### B.2 Mapping

Not present in the current version of this specification.

### B.3 Solution Set definitions

#### B.3.1 XML definition structure

Clause B.3.2 provides a graphical representation of the XML elements.

Clause B.3.3 provides XML definitions of CS IRP notifications as defined in 3GPP TS 32.352 [6].

Clause B.3.4 provides XML definitions of CS IRP IOCs as defined in 3GPP TS 32.352 [6].

#### B.3.2 Graphical Representation

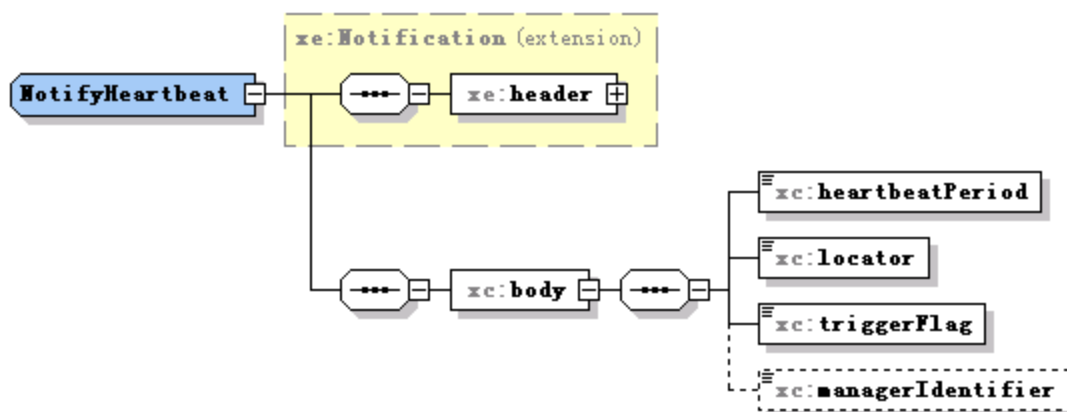

### B.3.3 XML Schema “cSIRPNotif.xsd”

```

<?xml version="1.0" encoding="UTF-8"?>
<!--
  3GPP TS 32.356 CSIRP Notification XML Schema
  cSIRPNotif.xsd
-->
<schema xmlns:xc="http://www.3gpp.org/ftp/specs/archive/32_series/32.356#cSIRPNotif"
  xmlns:xci="http://www.3gpp.org/ftp/specs/archive/32_series/32.356#cSIRPIOCs"
  xmlns:xe="http://www.3gpp.org/ftp/specs/archive/32_series/32.306#notification"
  xmlns="http://www.w3.org/2001/XMLSchema"
  targetNamespace="http://www.3gpp.org/ftp/specs/archive/32_series/32.356#cSIRPNotif"
  elementFormDefault="qualified" attributeFormDefault="unqualified">
  <import namespace="http://www.3gpp.org/ftp/specs/archive/32_series/32.356#cSIRPIOCs"/>
  <import namespace="http://www.3gpp.org/ftp/specs/archive/32_series/32.306#notification"/>
  <simpleType name="TriggerFlag">
    <restriction base="string">
      <enumeration value="IRPManager"/>
      <enumeration value="IRPAgent"/>
    </restriction>
  </simpleType>
  <complexType name="NotifyHeartbeat">
    <complexContent>
      <extension base="xe:Notification">
        <sequence>
          <element name="body">
            <complexType>
              <sequence>
                <element name="heartbeatPeriod" type="xci:HeartbeatPeriod"/>
                <element name="locator" type="string"/>
                <element name="triggerFlag" type="xc:TriggerFlag"/>
                <element name="managerIdentifier" type="string" minOccurs="0"/>
              </sequence>
            </complexType>
          </element>
        </sequence>
      </extension>
    </complexContent>
  </complexType>
  <element name="NotifyHeartbeat" type="xc:NotifyHeartbeat"/>
</schema>

```

### B.3.4 XML Schema “cSIRPIOC.xsd”

```
<?xml version="1.0" encoding="UTF-8"?>
<!--
  3GPP TS 32.356 CSIRP Notification XML Schema
  cSIRPIOCs.xsd
-->
<schema xmlns:xci="http://www.3gpp.org/ftp/specs/archive/32_series/32.356#cSIRPIOCs"
  xmlns:xe="http://www.3gpp.org/ftp/specs/archive/32_series/32.306#notification"
  xmlns="http://www.w3.org/2001/XMLSchema"
  targetNamespace="http://www.3gpp.org/ftp/specs/archive/32_series/32.356#cSIRPIOCs"
  elementFormDefault="qualified" attributeFormDefault="unqualified">
  <simpleType name="HeartbeatPeriod">
    <restriction base="unsignedLong">
      <fractionDigits value="0"/>
      <minInclusive value="5"/>
      <maxInclusive value="60"/>
    </restriction>
  </simpleType>
  <simpleType name="CountDownTimer">
    <restriction base="unsignedLong">
      <maxInclusive value="60"/>
    </restriction>
  </simpleType>
  <!-- attributes of the CSIRP IOC -->
  <element name="heartbeatPeriod" type="xci:HeartbeatPeriod"/>
  <element name="countDownTimer" type="xci:CountDownTimer"/>
</schema>
```

## Annex C (normative): SOAP Solution Set

The overall architectural feature of CM IRP is specified in 3GPP TS 32.352 [6].

This clause specifies features that are specific to the SOAP SS.

### C.1 Architectural Features

#### C.1.1 Syntax for Distinguished Names and versions

The syntax of a Distinguished Name is defined in 3GPP TS 32.300 [9].

The version of this IRP is represented as a string (see also clause 3.1).

#### C.1.2 General

The SOAP 1.1 specification [14] and WSDL 1.1 specification [16] are supported.

The SOAP 1.2 specification [17] is supported optionally.

This specification uses "document" style in WSDL file.

This specification uses "literal" encoding style in WSDL file.

The filter language used in the SS is the XPath Language (see W3C XPath 1.0 specification [15]). IRPAgents may throw a FilterComplexityLimit fault when a given filter is too complex.

Relevant definitions are imported from the CSIRP XML definitions of Annex B.

This specification uses a number of namespace prefixes throughout that are listed in Table C.1.2.

**Table C.1.2: Prefixes and Namespaces used in this specification**

PREFIX	NAMESPACE
(no prefix)	http://schemas.xmlsoap.org/wsdl/
soap	http://schemas.xmlsoap.org/wsdl/soap/
csIRPSystem	http://www.3gpp.org/ftp/specs/archive/32_series/32.356#CSIRPSystem
csIRPData	http://www.3gpp.org/ftp/specs/archive/32_series/32.356#CSIRPData
genericIRPSystem	http://www.3gpp.org/ftp/specs/archive/32_series/32.316#GenericIRPSystem
ntfIRPNtfSystem	http://www.3gpp.org/ftp/specs/archive/32_series/32.306#NotificationIRPNtfSystem

## C.2 Mapping

### C.2.1 Operation and Notification mapping

The CS IRP IS (3GPP TS 32.352 [6]) defines semantics of operation and notification visible across the Itf-N. Table C.2.1 indicates mapping of these operations and notifications to their equivalents defined in this SS.

**Table C.2.1: Mapping from IS Operation to SS Equivalents**

IS Operations in 3GPP TS 32.352 [6]	SS Operations	SS Port	Qualifier
getHeartbeatPeriod	getHeartbeatPeriod	NLIRPOperations1Port	M
setHeartbeatPeriod	setHeartbeatPeriod	NLIRPOperations2Port	O
triggerHeartbeat	triggerHeartbeat	NLIRPOperations1Port	M
notifyHeartbeat	notify (note 1)	NotificationIRPNtfPort	M
NOTE 1: The IS equivalent maps to an XML definition specified in Annex B, and this being an input parameter to the operation notify under the port type ntfIRPNtfSystem:NotificationIRPNtf and under the binding ntfIRPNtfSystem:NotificationIRPNtf of 3GPP TS 32.306 [7].			

### C.2.2 Operation parameter mapping

The CS IRP IS (3GPP TS 32.352 [6]) defines semantics of parameters carried in the operations. The tables below show the mapping of these parameters, as per operation, to their equivalents defined in this SS.

**Table C.2.2.1: Mapping from IS `getHeartbeatPeriod` parameters to SS equivalents**

IS Operation parameter	SS Method parameter	Qualifier
heartbeatPeriod	heartbeatPeriod	M
status	status	M

**Table C.2.2.2: Mapping from IS `setHeartbeatPeriod` parameters to SS equivalents**

IS Operation parameter	SS Method parameter	Qualifier
heartbeatPeriod	heartbeatPeriod	M
status	status	M

**Table C.2.2.3: Mapping from IS `triggerHeartbeat` parameters to SS equivalents**

IS Operation parameter	SS Method parameter	Qualifier
managerIdentifier	managerIdentifier	M
status	status	M

### C.2.3 Notification parameter mapping

The CS IRP Notifications are defined in Annex B.

## C.3 Solution Set definitions

### C.3.1 WSDL definition structure

Clause C.3.2 provides a graphical representation of the CS IRP service.  
Clause C.3.3 defines the services which are supported the CS IRP agent.

### C.3.2 Graphical Representation

The WSDL structure is depicted in Figure C.3.2 below, depicting port type, binding and service. The port type contains port type operations, which again contains input, output and fault messages. The binding contains binding operations, which have the same name as the port type operations. The binding connects to a port inside the service.

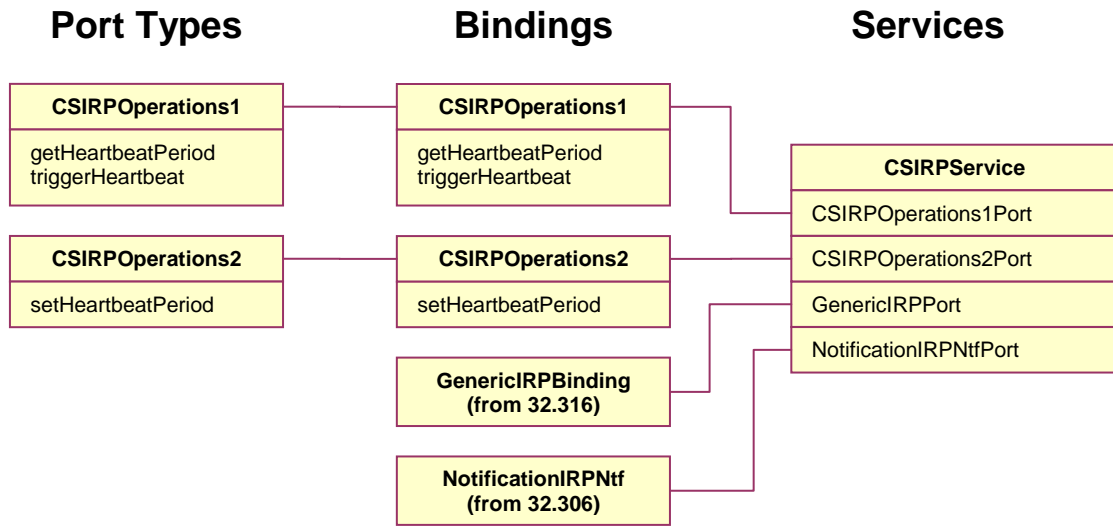

Figure C.3.2: CSIRP SOAP Solution Set WSDL structure

### C.3.3 WSDL specification "CSIRPSystem.wsdl"

```

<?xml version="1.0" encoding="UTF-8"?>
<!--
  3GPP TS 32.356 Communication Surveillance IRP SOAP Solution Set
-->
<definitions xmlns="http://schemas.xmlsoap.org/wsdl/"
  xmlns:soap="http://schemas.xmlsoap.org/wsdl/soap/"
  xmlns:csIRPSystem="http://www.3gpp.org/ftp/specs/archive/32_series/32.356#CSIRPSystem"
  xmlns:csIRPData="http://www.3gpp.org/ftp/specs/archive/32_series/32.356#CSIRPData"
  xmlns:genericIRPSystem="http://www.3gpp.org/ftp/specs/archive/32_series/32.316#GenericIRPSystem"
  xmlns:ntfIRPntfSystem="http://www.3gpp.org/ftp/specs/archive/32_series/32.306#NotificationIRPntfSystem"
  targetNamespace="http://www.3gpp.org/ftp/specs/archive/32_series/32.356#CSIRPSystem">
  <import namespace="http://www.3gpp.org/ftp/specs/archive/32_series/32.316#GenericIRPSystem"/>
  <import
  namespace="http://www.3gpp.org/ftp/specs/archive/32_series/32.306#NotificationIRPntfSystem"/>
  <types>
    <schema targetNamespace="http://www.3gpp.org/ftp/specs/archive/32_series/32.356#CSIRPData"
      xmlns="http://www.w3.org/2001/XMLSchema">
      <!-- getHeartbeatPeriod Request -->
      <element name="getHeartbeatPeriodRequest">
      </element>
      <!-- getHeartbeatPeriod Response -->
      <element name="getHeartbeatPeriodResponse">
      <complexType>
      <sequence>
      <element name="heartbeatPeriod" type="nonNegativeInteger"/>
      <element name="status">
      <simpleType>
      <restriction base="string">
      <enumeration value="OperationSucceeded"/>
      <enumeration value="OperationFailed"/>
      </restriction>
      </simpleType>
      </element>
      </sequence>
      </complexType>
      </element>
      <!-- getHeartbeatPeriod Fault -->
      <element name="getHeartbeatPeriodFault">
      <simpleType>
      <restriction base="string">
      <enumeration value="OperationFailed"/>
      </restriction>
      </simpleType>
      </element>
      <!-- triggerHeartbeat Request -->
      <element name="triggerHeartbeatRequest">
      <complexType>
      <sequence>
      <element name="managerIdentifier" type="string"/>
      </sequence>
      </complexType>
      </element>
      <!-- xx Response -->
      <element name="triggerHeartbeatResponse">
      <complexType>
      <sequence>
      <element name="status">
      <simpleType>
      <restriction base="string">
      <enumeration value="OperationSucceeded"/>
      <enumeration value="OperationFailed"/>
      </restriction>
      </simpleType>
      </element>
      <element name="failureReason" minOccurs="0">
      <simpleType>
      <restriction base="string">
      <enumeration value="invalidManagerIdentifier"/>
      <enumeration value="operation_failed_invalid_input_parameter"/>
      <enumeration value="operation_failed_internal_problem"/>
      </restriction>
      </simpleType>
      </sequence>
      </complexType>
    </schema>
  </types>

```

```

        </element>
      </sequence>
    </complexType>
  </element>
  <!-- triggerHeartbeat Fault -->
  <element name="triggerHeartbeatFault">
    <simpleType>
      <restriction base="string">
        <enumeration value="OperationFailed"/>
      </restriction>
    </simpleType>
  </element>
  <!-- setHeartbeatPeriod Request -->
  <element name="setHeartbeatPeriodRequest">
    <complexType>
      <sequence>
        <element name="heartbeatPeriod" type="nonNegativeInteger"/>
      </sequence>
    </complexType>
  </element>
  <!-- setHeartbeatPeriod Response -->
  <element name="setHeartbeatPeriodResponse">
    <complexType>
      <sequence>
        <element name="status">
          <simpleType>
            <restriction base="string">
              <enumeration value="OperationSucceeded"/>
              <enumeration value="OperationFailed"/>
            </restriction>
          </simpleType>
        </element>
        <element name="failureReason" minOccurs="0">
          <simpleType>
            <restriction base="string">
              <enumeration value="invalidHeartbeatPeriod"/>
              <enumeration value="conflictingHeartbeatPeriod"/>
              <enumeration value="operation_failed_invalid_input_parameter"/>
              <enumeration value="operation_failed_internal_problem"/>
            </restriction>
          </simpleType>
        </element>
      </sequence>
    </complexType>
  </element>
  <!-- setHeartbeatPeriod Fault -->
  <element name="setHeartbeatPeriodFault">
    <simpleType>
      <restriction base="string">
        <enumeration value="OperationFailed"/>
      </restriction>
    </simpleType>
  </element>
</schema>
</types>
<message name="getHeartbeatPeriodRequest">
  <part name="parameter" element="cs:IRPData:getHeartbeatPeriodRequest"/>
</message>
<message name="getHeartbeatPeriodResponse">
  <part name="parameter" element="cs:IRPData:getHeartbeatPeriodResponse"/>
</message>
<message name="getHeartbeatPeriodFault">
  <part name="parameter" element="cs:IRPData:getHeartbeatPeriodFault"/>
</message>
<message name="triggerHeartbeatRequest">
  <part name="parameter" element="cs:IRPData:triggerHeartbeatRequest"/>
</message>
<message name="triggerHeartbeatResponse">
  <part name="parameter" element="cs:IRPData:triggerHeartbeatResponse"/>
</message>
<message name="triggerHeartbeatFault">
  <part name="parameter" element="cs:IRPData:triggerHeartbeatFault"/>
</message>
<message name="setHeartbeatPeriodRequest">
  <part name="parameter" element="cs:IRPData:setHeartbeatPeriodRequest"/>
</message>
<message name="setHeartbeatPeriodResponse">
  <part name="parameter" element="cs:IRPData:setHeartbeatPeriodResponse"/>

```



```

</message>
<message name="setHeartbeatPeriodFault">
  <part name="parameter" element="csIRPData:setHeartbeatPeriodFault"/>
</message>
<portType name="CSIRPOperations1">
  <operation name="getHeartbeatPeriod">
    <input message="csIRPSystem:getHeartbeatPeriodRequest"/>
    <output message="csIRPSystem:getHeartbeatPeriodResponse"/>
    <fault name="getHeartbeatPeriodFault" message="csIRPSystem:getHeartbeatPeriodFault"/>
  </operation>
  <operation name="triggerHeartbeat">
    <input message="csIRPSystem:triggerHeartbeatRequest"/>
    <output message="csIRPSystem:triggerHeartbeatResponse"/>
    <fault name="triggerHeartbeatFault" message="csIRPSystem:triggerHeartbeatFault"/>
  </operation>
</portType>
<portType name="CSIRPOperations2">
  <operation name="setHeartbeatPeriod">
    <input message="csIRPSystem:setHeartbeatPeriodRequest"/>
    <output message="csIRPSystem:setHeartbeatPeriodResponse"/>
    <fault name="setHeartbeatPeriodFault" message="csIRPSystem:setHeartbeatPeriodFault"/>
  </operation>
</portType>
<binding name="CSIRPOperations1" type="csIRPSystem:CSIRPOperations1">
  <soap:binding style="document" transport="http://schemas.xmlsoap.org/soap/http"/>
  <operation name="getHeartbeatPeriod">
    <soap:operation
soapAction="http://www.3gpp.org/ftp/specs/archive/32_series/32.356#getHeartbeatPeriod"
style="document"/>
  <input>
    <soap:body use="literal"/>
  </input>
  <output>
    <soap:body use="literal"/>
  </output>
  <fault name="getHeartbeatPeriodFault">
    <soap:fault name="getHeartbeatPeriodFault" use="literal"/>
  </fault>
</operation>
  <operation name="triggerHeartbeat">
    <soap:operation
soapAction="http://www.3gpp.org/ftp/specs/archive/32_series/32.356#triggerHeartbeat"
style="document"/>
  <input>
    <soap:body use="literal"/>
  </input>
  <output>
    <soap:body use="literal"/>
  </output>
  <fault name="triggerHeartbeatFault">
    <soap:fault name="triggerHeartbeatFault" use="literal"/>
  </fault>
</operation>
</binding>
<binding name="CSIRPOperations2" type="csIRPSystem:CSIRPOperations2">
  <soap:binding style="document" transport="http://schemas.xmlsoap.org/soap/http"/>
  <operation name="setHeartbeatPeriod">
    <soap:operation
soapAction="http://www.3gpp.org/ftp/specs/archive/32_series/32.356#setHeartbeatPeriod"
style="document"/>
  <input>
    <soap:body use="literal"/>
  </input>
  <output>
    <soap:body use="literal"/>
  </output>
  <fault name="setHeartbeatPeriodFault">
    <soap:fault name="setHeartbeatPeriodFault" use="literal"/>
  </fault>
</operation>
</binding>
<service name="CSIRPService">
  <port name="CSIRPOperations1Port" binding="csIRPSystem:CSIRPOperations1">
    <soap:address location="http://www.3gpp.org/ftp/specs/archive/32_series/32.356#CSIRP"/>
  </port>
  <port name="CSIRPOperations2Port" binding="csIRPSystem:CSIRPOperations2">
    <soap:address location="http://www.3gpp.org/ftp/specs/archive/32_series/32.356#CSIRP"/>
  </port>

```

```
<port name="GenericIRPPort" binding="genericIRPSystem:GenericIRPBinding">
  <soap:address location="http://www.3gpp.org/ftp/specs/archive/32_series/32.316#GenericIRP"/>
</port>
<port name="NotificationIRPNotificationPort" binding="ntfIRPNotificationSystem:NotificationIRPNotification">
  <soap:address
location="http://www.3gpp.org/ftp/specs/archive/32_series/32.306#NotificationIRPNotification"/>
  </port>
</service>
</definitions>
```

---

## Annex D (informative): Change history

Change history							
Date	TSG #	TSG Doc.	CR	Rev	Subject/Comment	Old	New
2010-09	SA#49	SP-100512	--	--	Presentation to SA for Information and Approval	---	1.0.0
2010-10	--	--	--	--	Publication	1.0.0	10.0.0
2012-09	SA#57	-	-	-	Automatic upgrade from previous Release version 10.0.0	10.0.0	11.0.0