

3GPP TS 32.332 V11.0.0 (2012-09)

Technical Specification

**3rd Generation Partnership Project;
Technical Specification Group Services and System Aspects;
Telecommunication management;
Notification Log (NL) Integration Reference Point (IRP);
Information Service (IS)
(Release 11)**



The present document has been developed within the 3rd Generation Partnership Project (3GPP™) and may be further elaborated for the purposes of 3GPP. The present document has not been subject to any approval process by the 3GPP Organizational Partners and shall not be implemented. This Specification is provided for future development work within 3GPP only. The Organizational Partners accept no liability for any use of this Specification. Specifications and reports for implementation of the 3GPP™ system should be obtained via the 3GPP Organizational Partners' Publications Offices.

Keywords

UMTS, Management

3GPP

Postal address

3GPP support office address

650 Route des Lucioles - Sophia Antipolis
Valbonne - FRANCE
Tel.: +33 4 92 94 42 00 Fax: +33 4 93 65 47 16

Internet

<http://www.3gpp.org>

Copyright Notification

No part may be reproduced except as authorized by written permission.
The copyright and the foregoing restriction extend to reproduction in all media.

© 2012, 3GPP Organizational Partners (ARIB, ATIS, CCSA, ETSI, TTA, TTC).
All rights reserved.

UMTS™ is a Trade Mark of ETSI registered for the benefit of its members
3GPP™ is a Trade Mark of ETSI registered for the benefit of its Members and of the 3GPP Organizational Partners
LTE™ is a Trade Mark of ETSI currently being registered for the benefit of its Members and of the 3GPP Organizational Partners
GSM® and the GSM logo are registered and owned by the GSM Association

Contents

Foreword	6
Introduction	6
1 Scope	7
2 References.....	7
3 Definitions and abbreviations	7
3.1 Definitions	7
3.2 Abbreviations.....	8
4 System overview	8
4.2 Compliance rules	8
5 Information Object Classes (IOCs).....	9
5.1 Information entities imported and local labels	9
5.2 Class diagram.....	10
5.2.1 Attributes and relationships.....	10
5.2.2 Inheritance	11
5.3 Information Object Class (IOC) definitions.....	12
5.3.1 NLIRP	12
5.3.1.1 Definition	12
5.3.1.2 Attributes.....	12
5.3.2 Log.....	12
5.3.2.1 Definition	12
5.3.2.2 Attributes.....	12
5.3.2.3 State diagram.....	13
5.3.3 LogRecord	13
5.3.3.1 Definition	13
5.4 Information relationship definitions	14
5.4.1 Relation-nLIRP-log (M)	14
5.4.1.1 Definition	14
5.4.1.2 Role	14
5.4.1.3 Constraint.....	14
5.4.2 Relation-log-logRecord (M).....	14
5.4.2.1 Definition	14
5.4.2.2 Role	14
5.4.2.3 Constraint.....	14
5.4.3 Relation-logRecord-notificationIRPNotification (M).....	15
5.4.3.1 Definition	15
5.4.3.2 Role	15
5.4.3.3 Constraint.....	15
5.5 Information attribute definition	16
5.5.1 Definition and legal values	16
5.5.2 Constraints.....	17
6 Interface definition.....	17
6.1 Class diagram.....	17
6.2 Generic rules.....	18
6.3 NLIRPOperations_1 Interface (M).....	18
6.3.1 Operation subscribeLog (M)	18
6.3.1.1 Definition	18
6.3.1.2 Input parameters.....	18
6.3.1.3 Output parameters.....	19
6.3.1.4 Pre-condition	19
6.3.1.5 Post-condition.....	19
6.3.1.6 Exceptions.....	19

6.3.2	Operation unsubscribeLog (M).....	20
6.3.2.1	Definition	20
6.3.2.2	Input parameters.....	20
6.3.2.3	Output parameters.....	20
6.3.2.4	Pre-condition	20
6.3.2.5	Post-condition.....	20
6.3.2.6	Exceptions.....	20
6.3.3	Operation exportLogRecords (O).....	21
6.3.3.1	Definition	21
6.3.3.2	Input parameters.....	21
6.3.3.3	Output parameters.....	21
6.3.3.4	Pre-condition	21
6.3.3.5	Post-condition.....	21
6.3.3.6	Exceptions.....	21
6.3.4	Operation getLogRecords (O).....	22
6.3.4.1	Definition	22
6.3.4.2	Input parameters.....	22
6.3.4.3	Output parameters.....	22
6.3.4.4	Pre-condition	22
6.3.4.5	Post-condition.....	22
6.3.4.6	Exceptions.....	22
6.4	NLIRPOperations_2 Interface (O)	23
6.4.1	Operation getLogSubscriptionIds (M).....	23
6.4.1.1	Definition	23
6.4.1.2	Input parameters.....	23
6.4.1.3	Output parameters.....	23
6.4.1.4	Pre-condition	23
6.4.1.5	Post-condition.....	23
6.4.1.6	Exceptions.....	23
6.4.2	Operation getLogSubscriptionStatus (M).....	24
6.4.2.1	Definition	24
6.4.2.2	Input parameters.....	24
6.4.2.3	Output parameters.....	24
6.4.2.4	Pre-condition	24
6.4.2.5	Post-condition.....	24
6.4.2.6	Exceptions.....	24
6.5	NLIRPNotifications_1 Interface (M).....	25
6.5.1	Notification notifyLogSubscribed (M).....	25
6.5.1.1	Definition	25
6.5.1.2	Input Parameters	25
6.5.1.3	Triggering Event.....	25
6.5.1.3.1	From-state	25
6.5.1.3.2	To-state.....	25
6.5.2	Notification notifyLogUnsubscribed (M)	26
6.5.2.1	Definition	26
6.5.2.2	Input Parameters	26
6.5.2.3	Triggering Event.....	26
6.5.2.3.1	From-state	26
6.5.2.3.2	To-state.....	26
6.6	NLIRPNotifications_2 Interface (O).....	27
6.6.1	Notification notifyOccupancyLevelCrossed (M)	27
6.6.1.1	Definition	27
6.6.1.2	Input Parameters	27
6.6.1.3	Triggering Event.....	27
6.6.1.3.1	From-state	27
6.6.1.3.2	To-state.....	27
6.6.2	Notification notifyLoggingResumed (O)	28
6.6.2.1	Definition	28
6.6.2.2	Input Parameters	28
6.6.2.3	Triggering Event.....	28

6.6.2.3.1 From-state28
6.6.2.3.2 To-state.....28
Annex A (informative): Change history.....29

Foreword

This Technical Specification (TS) has been produced by the 3rd Generation Partnership Project (3GPP).

The contents of the present document are subject to continuing work within the TSG and may change following formal TSG approval. Should the TSG modify the contents of the present document, it will be re-released by the TSG with an identifying change of release date and an increase in version number as follows:

Version x.y.z

where:

- x the first digit:
 - 1 presented to TSG for information;
 - 2 presented to TSG for approval;
 - 3 or greater indicates TSG approved document under change control.
- y the second digit is incremented for all changes of substance, i.e. technical enhancements, corrections, updates, etc.
- z the third digit is incremented when editorial only changes have been incorporated in the document.

Introduction

The present document is part of a TS-family covering the 3rd Generation Partnership Project; Technical Specification Group Services and System Aspects; Telecommunication management; as identified below:

- | | |
|------------------|--|
| TS 32.331 | "Notification Log (NL) Integration Reference Point (IRP): Requirements" |
| TS 32.332 | "Notification Log (NL) Integration Reference Point (IRP): Information Service (IS)" |
| TS 32.336 | "Notification Log (NL) Integration Reference Point (IRP); Solution Set (SS) definitions" |

The present document describes the requirements and information model necessary for Telecommunication Management (TM). The TM principles and TM architecture are specified in 3GPP TS 32.101 [1] and 3GPP TS 32.102 [2].

A communications system is composed of a multitude of Network Elements (NE) of various types and, typically, different vendors, which inter-operate in a co-ordinated manner in order to satisfy the network users' communication requirements.

The occurrence of faults in an NE may cause deterioration or loss of this NE's function. Fault Management is the functional area, which allows the operator to detect the occurrence of faults in the network in real-time. Configuration Management and Performance Management are two more functional areas, which require the operator to be alerted to certain conditions in the network.

A standard general-purpose mechanism for the management of logs containing selected notifications from the network is required to provide an ability to perform historical analysis on faults and conditions, which occurred in the network. The TS 32.33x-series, constituting the Notification log IRP, sets forth such a mechanism - and the present document contains the IS definition.

1 Scope

The present document specifies the Information Service for the Notification Log Integration Reference Point (NLIRP) as it applies to Itf-N.

This IRP IS defines the semantics of operations (and their parameters) visible across the Itf-N in a protocol and technology neutral way. It does not define the syntax or encoding of the operations and their parameters.

2 References

The following documents contain provisions, which through reference in this text constitute provisions of the present document.

- References are either specific (identified by date of publication, edition number, version number, etc.) or non-specific.
- For a specific reference, subsequent revisions do not apply.
- For a non-specific reference, the latest version applies. In the case of a reference to a 3GPP document (including a GSM document), a non-specific reference implicitly refers to the latest version of that document *in the same Release as the present document*.

- [1] 3GPP TS 32.101: "Telecommunication management; Principles and high level requirements".
- [2] 3GPP TS 32.102: "Telecommunication management; Architecture".
- [3] 3GPP TS 32.302: "Telecommunication management; Configuration Management (CM); Notification Integration Reference Point (IRP): Information Service (IS)".
- [4] 3GPP TS 32.622: "Telecommunication management; Configuration Management (CM); Generic network resources Integration Reference Point (IRP): Network Resource Model (NRM)".
- [5] 3GPP TS 32.111-2: "Telecommunication management; Fault Management; Part 2: Alarm Integration Reference Point (IRP): Information Service (IS)".
- [6] 3GPP TS 32.312: "Telecommunication management; Generic Integration Reference Point (IRP) management; Information Service (IS)".
- [7] 3GPP TS 32.331: "Telecommunication management; Notification Log (NL) Integration Reference Point (IRP): Requirements".
- [8] 3GPP TS 32.342: "Telecommunication management; File Transfer (FT) Integration Reference Point (IRP): Information Service (IS)".
- [9] 3GPP TS 32.150: "Telecommunication management; Integration Reference Point (IRP) Concept and definitions".

3 Definitions and abbreviations

3.1 Definitions

For the purposes of the present document, the terms and definitions given in 3GPP TS 32.101 [1], 3GPP TS 32.102 [2], 3GPP TS 32.111-2 [5] and 3GPP TS 32.331 [7] apply.

notification category: it refers to the set of notifications of one 3GPP IRP Information Service specification. A Notification Category is identified by the name of the IRP specification and the IRP specification version number.

3.2 Abbreviations

For the purposes of the present document, the following abbreviations apply:

DN	Distinguished Name
EM	Element Manager
FT	File Transfer
IOC	Information Object Class
IRP	Integration Reference Point
M	Mandatory
NE	Network Element
NL	Notification Log
NLIRP	Notification Log Integration Reference Point
NM	Network Manager
O	Optional
UML	Unified Modelling Language

4 System overview

The general definition of the System Context for the present IRP is found in 3GPP TS 32.150 [9] clause 4.7.

In addition, the set of related IRP(s) relevant to the present IRP is shown in the two diagrams below

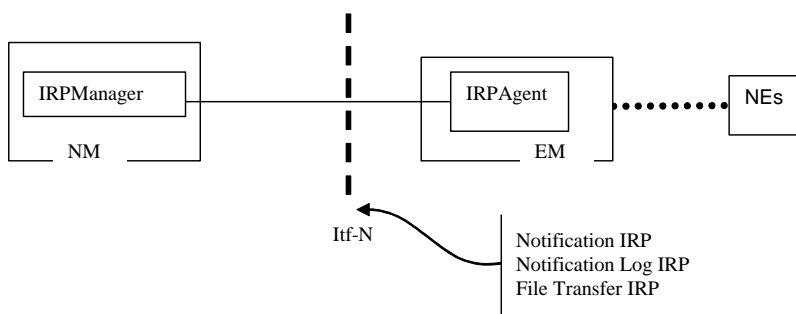

Figure 4.1: System Context A

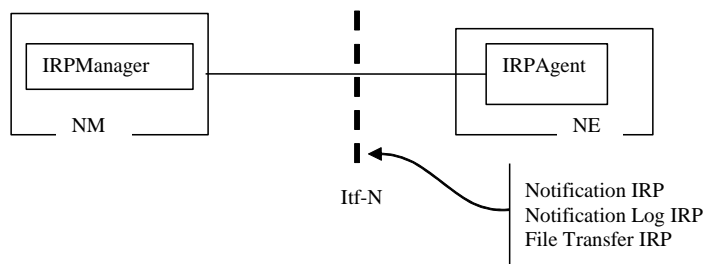

Figure 4.2: System Context B

4.2 Compliance rules

For general definitions of compliance rules related to qualifiers (Mandatory/Optional/Conditional) for *operations*, *notifications* and *parameters* (of operations and notifications) please refer to 3GPP TS 32.102 [2].

5 Information Object Classes (IOCs)

5.1 Information entities imported and local labels

Label reference	Local label
3GPP TS 32.622 [4], information object class, Top	Top
3GPP TS 32.312 [6], information object class, ManagedGenericIRP	ManagedGenericIRP
3GPP TS 32.342 [8], information object class, FileTransferIRP	FileTransferIRP
3GPP TS 32.302 [3], information object class, NotificationIRP	NotificationIRP
3GPP TS 32.302 [3], information object class, NotificationIRPNotification	NotificationIRPNotification

5.2 Class diagram

5.2.1 Attributes and relationships

This clause introduces the set of IOCs that encapsulate information within the `IRPAgent`. The intent is to identify the information required for NLIRP operations and notification. This clause provides the overview of all support object classes in UML. Subsequent clauses provide more detailed specification of various aspects of these support object classes.

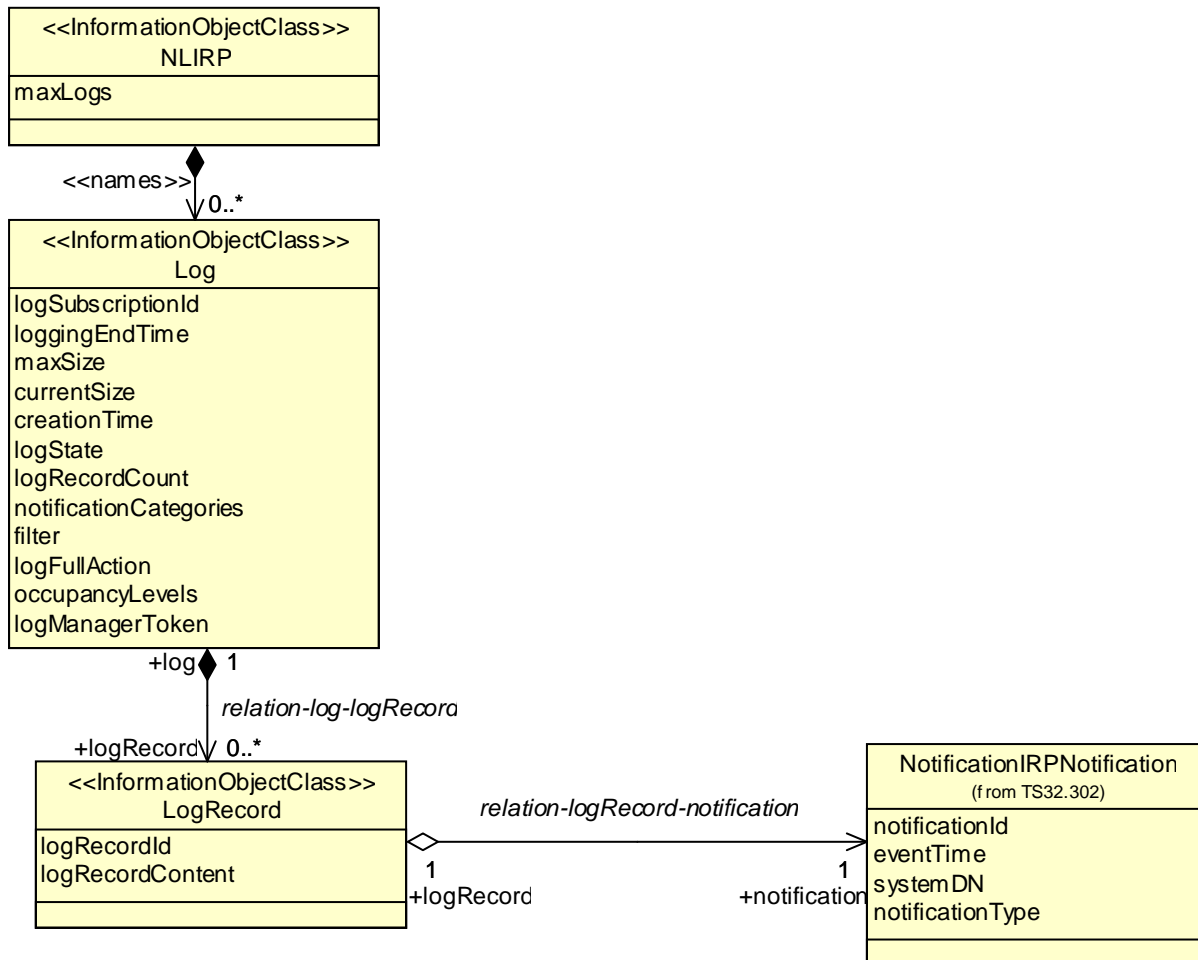

Figure 5.1: Information Object Class (IOC) UML diagram

To change: change logid, add logrecordcontent, remove logrecordsource.

5.2.2 Inheritance

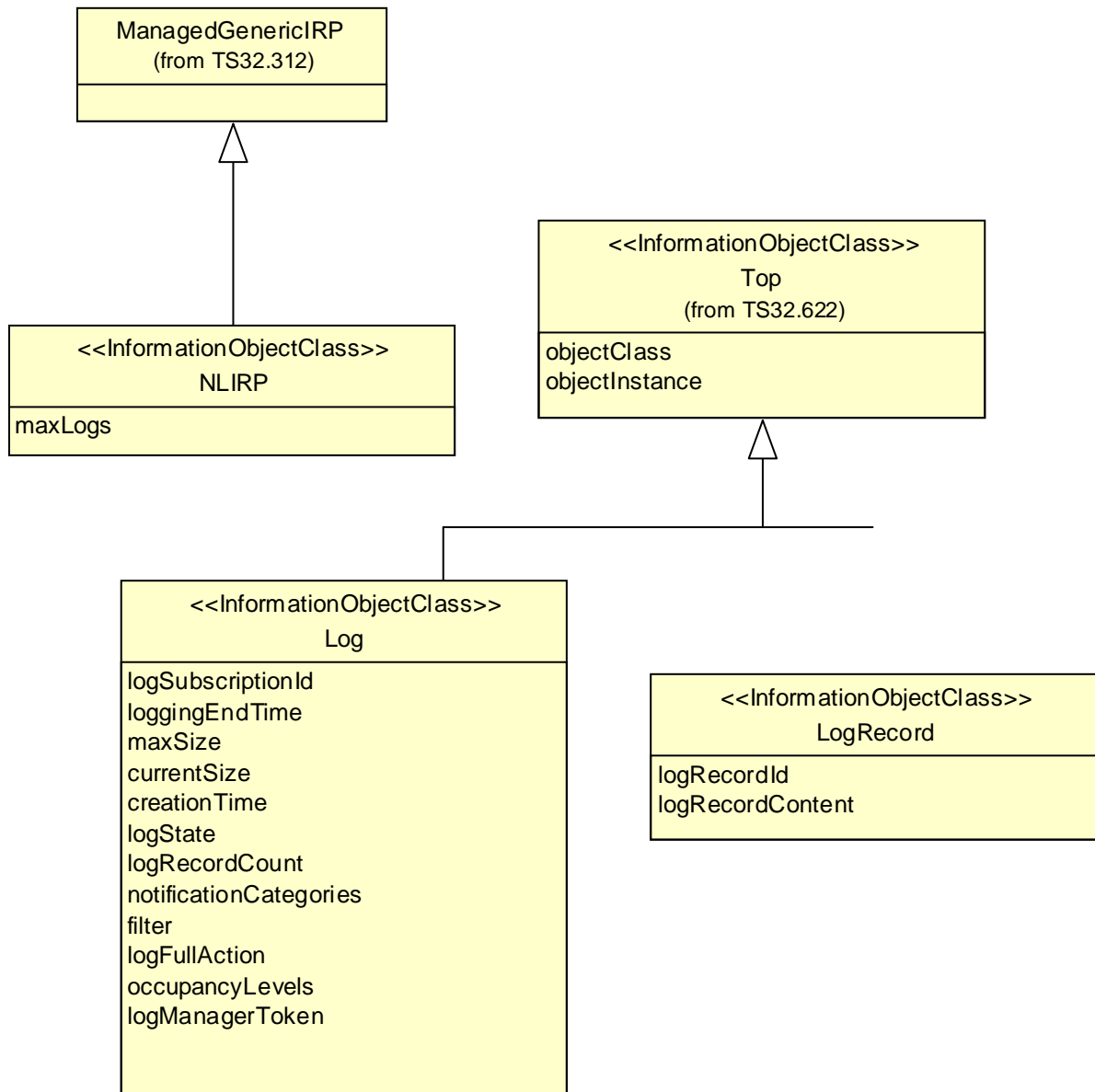

Figure 5.2: Information Object Class (IOC) inheritance UML diagram

5.3 Information Object Class (IOC) definitions

5.3.1 NLIRP

5.3.1.1 Definition

LogIRP is the representation of the notification log management capabilities specified by the present document. This IOC inherits from ManagedGenericIRP IOC specified in TS 32.312 [6].

5.3.1.2 Attributes

Attribute name	Support Qualifier	Read Qualifier	Write Qualifier
maxLogs	O	M	-

5.3.2 Log

5.3.2.1 Definition

The Log IOC is the representation of a Notification Log.

5.3.2.2 Attributes

Attribute name	Support Qualifier	Read Qualifier	Write Qualifier
logSubscriptionId	M	M	-
loggingEndTime	O	M	-
logManagerToken	O	-	-
maxSize	O	M	-
currentSize	O	M	-
creationTime	O	M	-
logState	M	M	-
logRecordCount	O	M	-
notificationCategories	O	M	-
filter	O	M	-
logFullAction	M	M	-
occupancyLevels	M	M	-

5.3.2.3 State diagram

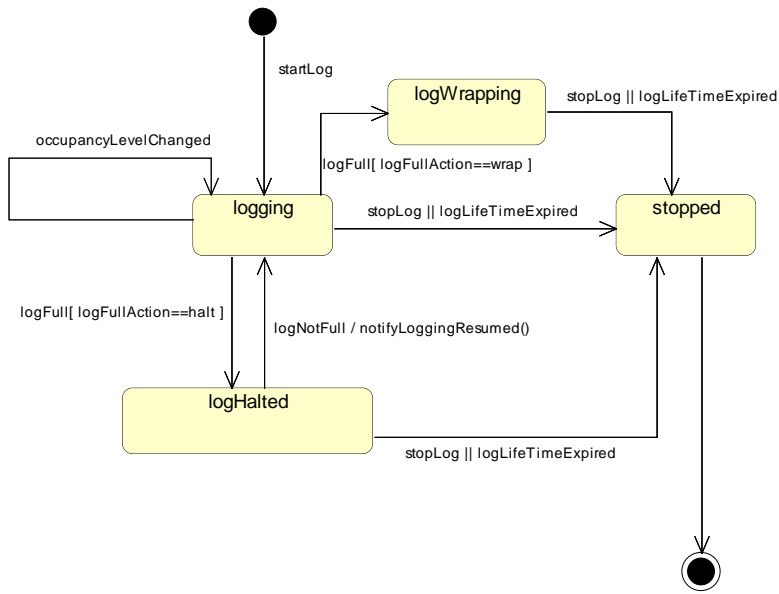

Figure 5.3: State diagram for Notification Log

The disposition of a log that has been stopped, that is, whether the log remains visible across the Itf-N, is left as vendor specific functionality. The time of the deletion of logs is vendor specific.

5.3.3 LogRecord

5.3.3.1 Definition

The LogRecord IOC is the representation of an individual Notification Log Record.

Attribute name	Support Qualifier	Read Qualifier	Write Qualifier
logRecordId	M	M	-
logRecordContent	O	M	-

5.4 Information relationship definitions

5.4.1 Relation-nLIRP-log (M)

5.4.1.1 Definition

This represents the relationship between NLIRP and the Log.

5.4.1.2 Role

Name	Definition
nLIRP	It represents the NLIRP.
log	It represents the Log.

5.4.1.3 Constraint

Name	Definition
uniqueLogSubscriptionId	The log subscription id must be unique amongst all logs managed by a given NLIRP instance.
uniqueLogManagerToken	The log manager token must be unique amongst all managers and logs utilizing logging services from a given NLIRP instance.

5.4.2 Relation-log-logRecord (M)

5.4.2.1 Definition

This represents the relationship between Log and the LogRecord.

5.4.2.2 Role

Name	Definition
log	It represents the Log.
logRecord	It represents the LogRecord.

5.4.2.3 Constraint

Name	Definition
uniqueLogRecordId	The log record id must be unique amongst all logs records within a given log.

5.4.3 Relation-logRecord-notificationIRPNotification (M)

5.4.3.1 Definition

This represents the relationship between `LogRecord` and the notification header represented by `NotificationIRPNotification`.

5.4.3.2 Role

Name	Definition
<code>logRecord</code>	It represents the <code>LogRecord</code> .
<code>notification</code>	It represents the <code>NotificationIRPNotification</code> .

5.4.3.3 Constraint

Name	Definition
<code>logRecordIdRelatesNotificationId</code>	Within a given log, there is a one-to-one relationship between <code>Notification Id</code> and <code>Log Id</code> (as each notification can only be recorded once).

5.5 Information attribute definition

5.5.1 Definition and legal values

Attribute Name	Definition	Legal Values
creationTime	The time when the log is created.	YYYYMMDDhhmmss
currentSize	This attribute provides the number of bytes currently utilized by a given log. When taken in conjunction with maxSize, the amount of space remaining in the log can be determined.	Either: <ul style="list-style-type: none"> ○ zero ○ a positive whole number
filter	It specifies a filter constraint that IRP Agent shall use to filter notification of the category specified in notificationCategories parameter. Support of time based filter is mandatory. Support of other filter constraints is optional.	Filter constraint grammar is SS dependent
logFullAction	Indicate the action that will be taken by this instance of NLIRP when the Log.maxSize has been reached.	An ENUM that can have one of the following values: <ul style="list-style-type: none"> ○ wrap: The oldest LogRecord(s) in the Log, based on the log time, will be deleted to free resources for the logging of new LogRecord(s). ○ halt: No more LogRecord(s) will be logged and all incoming events are discarded. LogRecord/s already in the Log will be retained.
loggingEndTime	Defines the date and time when the log stops logging.	If log is created by IRPManager: <ul style="list-style-type: none"> ○ value provided by the IRP Manager - the IRP Agent may reject the value provided by the IRP Manager in case this value is excessive ○ in case no value is provided by the IRP Manager then this value is set by the IRP Agent. If log is created by IRP Agent: <ul style="list-style-type: none"> ○ value indicates date and time or ○ value is expressed as "indefinite".
logManagerToken	This attribute contains the token of a manager utilizing logging services from a given NLIRP instance, assigned by the IRP Agent.	The value of this attribute must be unique amongst all managers and logs utilizing logging services from the given NLIRP instance.
logRecordContent	The notification information of a log record, excluding the notification header information.	The content format varies depending on the type of the notification.
logRecordCount	The number of log records currently logged within a given log.	positive whole number, including zero
logRecordId	This attribute contains the id of a log record within a given log, assigned by the IRP Agent.	The value of this attribute must be unique amongst all log record contained by a given log.
logState	Provides an indication of the current state of a specific log	An ENUM that can have one of the following values: <ul style="list-style-type: none"> ○ logging ○ logFull ○ stopped
logSubscriptionId	This attribute contains the id of a log subscription within a given NLIRP instance, assigned by the IRP Agent.	The value of this attribute must be unique amongst all log subscriptions managed by a given NLIRP instance.
maxLogs	Defines the maximum number of logs that can be supported by a given Notification Log IRP, assigned by the IRP Agent.	Non-zero, positive whole number
maxSize	This attribute defines the maximum number of bytes that may be utilized by a given log, assigned by the IRP Agent.	Either: <ul style="list-style-type: none"> ○ Non-zero, positive whole number ○ Zero indicates no limit on the number of records is set by the IRP Agent (log full handling will provide limitation information)
notificationCategories	Specifies the notification categories that can be recorded within a given log - SET OF (name of IRP, version of IRP)	It identifies one or more Notification Category (see also Definition in clause 3.1)
occupancyLevels	Case Log.logFullAction == 'halt' and Log.maxSize is non-zero: <ul style="list-style-type: none"> ○ this attribute contains a list of 3 values fixed (determined by the IRP Agent and never changed) of percentage, of Log.maxLog ○ the NLIRP will generate notifyOccupancyLevelCrossed to alert IRPManagers about the Log capacity currently used. Case Log.logFullAction == 'wrap': <ul style="list-style-type: none"> ○ this attribute contains 1 value fixed (determined by the IRP Agent and never changed) of percentage of Log.maxLog ○ the NLIRP will generate notifyOccupancyLevelCrossed to alert IRPManagers that the specified percentage of the capacity has been written to the wrapping Log. 	Case of 'halt': a set of 3 values. Case of 'wrap': 1 value.

5.5.2 Constraints

Name	Definition
inv_lastModifiedTime	Time indicated shall be greater than or equal to creationTime
inv_logRecordCount	Number indicated shall be less than or equal to maxSize

6 Interface definition

6.1 Class diagram

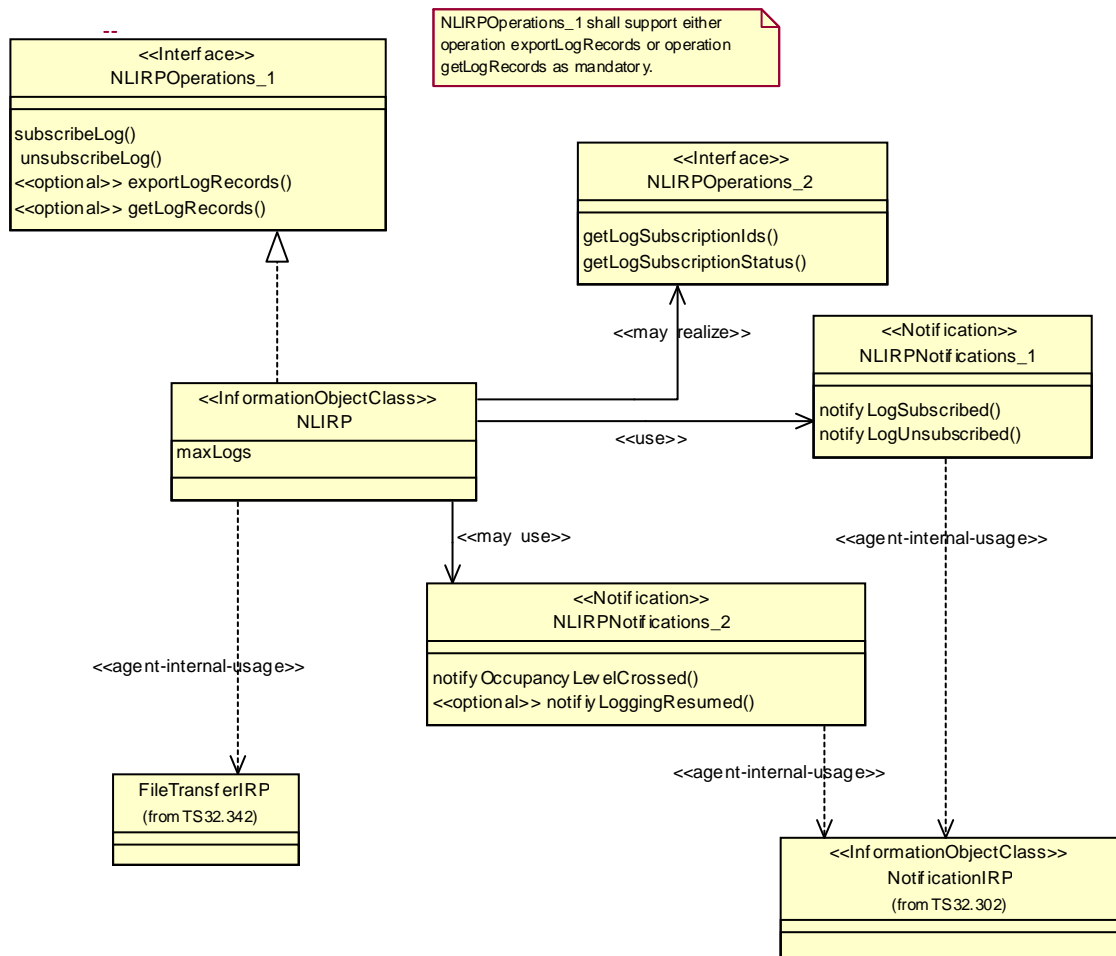

Figure 6.1: Class diagram

NLIRPOperations_1 shall support either operation exportLogRecords or operation getLogRecords as mandatory.

6.2 Generic rules

- Rule 1:** Each operation with at least one input parameter supports a pre-condition `valid_input_parameter` which indicates that all input parameters shall be valid with regards to their information type. Additionally, each such operation supports an exception `operation_failed_invalid_input_parameter` which is raised when pre-condition `valid_input_parameter` is false. The exception has the same entry and exit state.
- Rule 2:** Each operation with at least one optional input parameter supports a set of pre-conditions `supported_optional_input_parameter_xxx` where "xxx" is the name of the optional input parameter and the pre-condition indicates that the operation supports the named optional input parameter. Additionally, each such operation supports an exception `operation_failed_unsupported_optional_input_parameter_xxx` which is raised when (a) the pre-condition `supported_optional_input_parameter_xxx` is false and (b) the named optional input parameter is carrying information. The exception has the same entry and exit state.
- Rule 3:** Each operation shall support a generic exception `operation_failed_internal_problem` which is raised when an internal problem occurs and that the operation cannot be completed. The exception has the same entry and exit state.

6.3 NLIRPOperations_1 Interface (M)

6.3.1 Operation subscribeLog (M)

6.3.1.1 Definition

Using this operation, an IRPManager is initiating the logging of notifications. Resulting from this operation an IRPAgent shall start logging of notifications and, if necessary, also create an associated log.

6.3.1.2 Input parameters

Parameter Name	Qualifier	Information type	Comment
<code>logSubscriptionId</code>	M	<code>Log.logSubscriptionId</code>	See clause 5.5.1 If empty, then IRPAgent shall create a new log and return the <code>logSubscriptionId</code> as output parameter. However not all IRPAgents will provide this capability, i.e. IRPManager must provide an existing <code>logSubscriptionId</code> .
<code>loggingEndTime</code>	O	<code>Log.loggingEndTime</code>	See clause 5.5.1
<code>notificationCategories</code>	O	<code>Log.notificationCategories</code>	See clause 5.5.1; if <code>notificationCategories</code> is absent than all notifications are logged
<code>filter</code>	O	<code>Log.ntfFilterfilter</code> Filter constraint grammar is SS dependent	See clause 5.5.1; if this parameter is absent, then no filter constraint shall be applied.

6.3.1.3 Output parameters

Parameter Name	Qualifier	Matching Information	Comment
logSubscriptionId	M	Log.logSubscriptionId	See clause 5.5.1 This parameter contains either <ul style="list-style-type: none"> ○ the logSubscriptionId of the log created resulting from this operation or ○ the value of the input parameter logSubscriptionId.
logManagerToken	O	Log.logManagerToken	See clause 5.5.1 See also comment 6.3.2.2. Note: Security Management IRP may provide capabilities that make this parameter redundant.
loggingEndTime	O	Log.loggingEndTime	See clause 5.5.1 If supported by the Log IOC (5.3.2) and not already provided by the IRP Manager then the output of this operation must support this parameter.
status	M	ENUM (OperationSucceeded, OperationFailed)	If loggingEndTime is valid and notificationCategories is valid or absent, status = OperationSucceeded. If operation_failed is true, status = OperationFailed. If loggingEndTime excessive, status = OperationFailed.

6.3.1.4 Pre-condition

logsNotMaxed

Assertion Name	Definition
logsNotMaxed	The number of logs is less than the maximum number of logs allowed.

6.3.1.5 Post-condition

logStarted

Assertion Name	Definition
logStarted	A log is started with the specified characteristics (lifetime and notificationCategories).

6.3.1.6 Exceptions

Exception Name	Definition
logSubscriptionId_required	Condition: Pre-condition is true AND post-condition is false. Returned Information: The output parameter status. Exit state: Entry state.
maxLogs_reached	Condition: Pre-condition is true AND post-condition is false. Returned Information: The output parameter status. Exit state: Entry state.
operation_failed	Condition: Pre-condition is true AND post-condition is false. Returned Information: The output parameter status. Exit state: Entry state.

6.3.2 Operation unsubscribeLog (M)

6.3.2.1 Definition

Using this operation, the IRPManager that started a specific log is able to stop this log via unsubscribing. Note stopping a log implies that the log becomes invisible across Itf-N, independent from the loggingEndTime; therefore the IRPManager should retrieve log information of interest before using this unsubscribeLog operation, e.g. through the exportLogRecords operation.

The disposition of a log that has been stopped, that is, whether the log remains visible across the Itf-N, is left as vendor specific functionality. The time of the deletion of logs is vendor specific.

In consideration of a multi-manager environment, the log can only be stopped by the creating IRPManager if this IRPManager provided a related token while initiating subscribeLog.

6.3.2.2 Input parameters

Parameter Name	Qualifier	Information type	Comment
logSubscriptionId	M	Log.logSubscriptionId	See clause 5.5.1
logManagerToken	O	Log.logManagerToken	See clause 5.5.1 If subscribeLog returned a logManagerToken for a log with logSubscriptionId="X", then logManagerToken must be provided as input parameter of this operation to successfully stop log with logSubscriptionId="X". If subscribeLog did not return a logManagerToken for a log with logSubscriptionId="X", then logManagerToken must contain NULL value to successfully stop log with logSubscriptionId="X".

6.3.2.3 Output parameters

Parameter Name	Qualifier	Matching Information	Comment
status	M	ENUM (OperationSucceeded, OperationFailed)	If logSubscriptionId is valid and logManagerToken (if supported) is matching, status = OperationSucceeded. If operation_failed is true, status = OperationFailed.

6.3.2.4 Pre-condition

There are no pre-conditions, other than those established by the generic rules (see clause 6.2).

6.3.2.5 Post-condition

logStopped

Assertion Name	Definition
logStopped	The specified log is stopped.

6.3.2.6 Exceptions

Exception Name	Definition
operation_failed	Condition: Pre-condition is true AND post-condition is false. Returned Information: The output parameter status. Exit state: Entry state.

6.3.3 Operation exportLogRecords (O)

Support for this operation is mandatory if getLogRecords is not supported.

6.3.3.1 Definition

Using this operation, an IRPManager can initiate export of all or part of a log into a file. This file then is being transferred to the IRPManager using the File Transfer IRP (note also that the FTIRP is providing the file location to the IRPManager).

6.3.3.2 Input parameters

Parameter Name	Qualifier	Information type	Comment
logSubscriptionId	M	Log.logSubscriptionId	See clause 5.5.1
notificationCategories	O	Log.notificationCategories	See clause 5.5.1
filter	O	Log.filterLog.filter	See clause 5.5.1

6.3.3.3 Output parameters

Parameter Name	Qualifier	Matching Information	Comment
invocationId	M	--	<p>This parameter carries an identifier that NLIRP assigns to identify the request if the status is OperationSucceeded. This parameter carries no information if the status is not OperationSucceeded.</p> <p>One identifier can at most identify one request. NLIRP should not reuse identifier values.</p> <p>This identifier shall also appear in the file name of the exported log file as <specificIRP_extension> (as part specified in Appendix A: File Name Convention of [8]).</p> <p>When the exported log file is ready, FTIRP issues notifyFileReady notification which carries the exported log file name.</p>

6.3.3.4 Pre-condition

There are no pre-conditions, other than those established by the generic rules (see clause 6.2).

6.3.3.5 Post-condition

logRecordsExported

Assertion Name	Definition
logRecordsExported	The specified log records have been exported as requested. In case the log is empty or in case that all the log records do not satisfy the criteria of input parameters notificationCategories and filter, this post-condition is true.

6.3.3.6 Exceptions

Exception Name	Definition
export_failed	The NLIRP was unable to export the specified records.
operation_failed	<p>Condition: Pre-condition is true AND post-condition is false.</p> <p>Returned Information: The output parameter status.</p> <p>Exit state: Entry state.</p>

6.3.4 Operation `getLogRecords` (O)

Support for these operations is mandatory if `exportLogRecords` is not supported.

6.3.4.1 Definition

Using this operation, an IRPManager can retrieve one or more log records from a certain log.

Note that this operation might be preferred for retrieval of small amounts of log records, while operation `exportLogRecords` might be preferred for retrieval of medium to large amounts of log records, as providing a more efficient bulk transfer mechanism.

6.3.4.2 Input parameters

Parameter Name	Qualifier	Information type	Comment
<code>logSubscriptionId</code>	M	Log.logSubscriptionId	See clause 5.5.1
<code>notificationCategories</code>	O	Log.notificationCategories	See clause 5.5.1
<code>filter</code>	O	Log.filter	See clause 5.5.1

6.3.4.3 Output parameters

Parameter Name	Qualifier	Matching Information	Comment
<code>getLogRecordsResult</code>	M	List of logRecord's	List of logRecords; each entry of the list holds all supported attributes of IOC LogRecord (see 5.3.3.2).
<code>status</code>	M	ENUM (OperationSucceeded, OperationFailed)	If logSubscriptionId is valid and (logRecordIdList is empty or logRecordIdList contains valid Id's), status = OperationSucceeded. If operation_failed is true, status = OperationFailed.

6.3.4.4 Pre-condition

There are no pre-conditions, other than those established by the generic rules (see clause 6.2).

6.3.4.5 Post-condition

`logRecordsRetrieved`

Assertion Name	Definition
<code>logRecordsRetrieved</code>	The specified log records have been retrieved as requested. If the log is empty or all the log records do not satisfy the criteria of input parameters <code>notificationCategories</code> and <code>filter</code> , this post-condition is true.

6.3.4.6 Exceptions

Exception Name	Definition
<code>operation_failed</code>	Condition: Pre-condition is true AND post-condition is false. Returned Information: The output parameter <code>status</code> . Exit state: Entry state.

6.4 NLIRPOperations_2 Interface (O)

6.4.1 Operation getLogSubscriptionIds (M)

6.4.1.1 Definition

Using this operation, an IRPManager can query the NLIRP for all available log subscriptions.

6.4.1.2 Input parameters

Parameter Name	Qualifier	Information type	Comment
--	--	--	--

6.4.1.3 Output parameters

Parameter Name	Qualifier	Matching Information	Comment
logSubscriptionIds	M	List of logSubscriptionId's	See clause 5.5.1 & 6.4.1.2. Note that empty list is a valid value.
status	M	ENUM (OperationSucceeded, OperationFailed)	If operation is successful, status = OperationSucceeded. If operation_failed is true, status = OperationFailed.

6.4.1.4 Pre-condition

There are no pre-conditions, other than those established by the generic rules (see clause 6.2).

6.4.1.5 Post-condition

There are no post-conditions. Querying of log subscription Id's does not result in any changes within the IRP Agent.

6.4.1.6 Exceptions

Exception Name	Definition
operation_failed	Condition: Pre-condition is true AND post-condition is false. Returned Information: The output parameter status. Exit state: Entry state.

6.4.2 Operation getLogSubscriptionStatus (M)

6.4.2.1 Definition

Using this operation, an IRPManager can query the NLIRP for available log status information of an individual log.

6.4.2.2 Input parameters

Parameter Name	Qualifier	Information type	Comment
logSubscriptionId	M	Log.logSubscriptionId	See clause 5.5.1

6.4.2.3 Output parameters

Parameter Name	Qualifier	Matching Information	Comment
logAttributeList	M	Attributes of related Log IOC except logManagerToken	List of all supported attributes of IOC Log except logManagerToken (see clause 5.3.2.2).
status	M	ENUM (OperationSucceeded, OperationFailed)	If logSubscriptionId is valid status = OperationSucceeded. If operation_failed is true, status = OperationFailed.

6.4.2.4 Pre-condition

There are no pre-conditions, other than those established by the generic rules (see clause 6.2).

6.4.2.5 Post-condition

There are no post-conditions. Querying of log attributes does not result in any changes within the IRPAgent.

6.4.2.6 Exceptions

Exception Name	Definition
operation_failed	Condition: Pre-condition is true AND post-condition is false. Returned Information: The output parameter status. Exit state: Entry state.

6.5 NLIRPNotifications_1 Interface (M)

6.5.1 Notification notifyLogSubscribed (M)

6.5.1.1 Definition

Using this notification, an IRPAgent informs all subscribed IRPManagers that a log subscription has been successfully initiated.

6.5.1.2 Input Parameters

Parameter Name	Qualifier	Matching Information	Comment
objectClass	M,Y	Log.objectClass	Notification header - see [3]. It shall carry the Log class name.
objectInstance	M,Y	Log.objectInstance	Notification header - see [3]. It shall carry the DN of Log.
notificationId	M,N	--	Notification header - see [3].
eventTime	M,Y	--	Notification header - see [3].
notificationType	M,Y	"notifyLogSubscribed"	Notification header - see [3].
systemDN	C,Y	--	Notification header - see [3].
logSubscriptionId	M,N	Log.logSubscriptionId	See clause 5.5.1
loggingEndTime	O,N	Log.loggingEndTime	See clause 5.5.1
notificationCategories	O,N	Log.notificationCategories	See clause 5.5.1; if absent than all notifications are being logged
filter	O,N	Log.filter	See clause 5.5.1

6.5.1.3 Triggering Event

6.5.1.3.1 From-state

subscribeLog

Assertion Name	Definition
subscribeLog	An IRPManager requests that a new log be started.

6.5.1.3.2 To-state

logStarted

Assertion Name	Definition
logStarted	The NLIRP has started the requested logging activity.

6.5.2 Notification notifyLogUnsubscribed (M)

6.5.2.1 Definition

Using this notification, an IRPAgent informs all subscribed IRPManager that a log subscription has stopped.

6.5.2.2 Input Parameters

Parameter Name	Qualifier	Matching Information	Comment
objectClass	M,Y	Log.objectClass	See table 6.5.1.2.
objectInstance	M,Y	Log.objectInstance	See table 6.5.1.2.
notificationId	M,N	--	See table 6.5.1.2.
eventTime	M,Y	--	See table 6.5.1.2.
notificationType	M,Y	"notifyLogUnsubscribed"	See table 6.5.1.2.
systemDN	C,Y	--	See table 6.5.1.2.
logSubscriptionId	M,N	Log.logSubscriptionId	See table 6.5.1.2.

6.5.2.3 Triggering Event

6.5.2.3.1 From-state

unsubscribeLog OR loggingEndTimeReached

Assertion Name	Definition
unsubscribeLog	The IRPManager that started the log requests that the log be unsubscribed.
loggingEndTimeReached	The logging end time specified for the log in subscribeLog has been reached.

6.5.2.3.2 To-state

logStopped

Assertion Name	Definition
logStopped	The logging activity has stopped.

6.6 NLIRPNotifications_2 Interface (O)

6.6.1 Notification notifyOccupancyLevelCrossed (M)

6.6.1.1 Definition

Using this notification, an IRP Agent informs all subscribed IRP Managers about the occupancy level of a certain log according with levels defined in 5.5.1 (in addition also the log full action type of this NLIRP instance is being provided for context purposes).

6.6.1.2 Input Parameters

Parameter Name	Qualifier	Matching Information	Comment
objectClass	M,Y	Log.objectClass	See table 6.5.1.2.
objectInstance	M,Y	Log.objectInstance	See table 6.5.1.2.
notificationId	M,N	--	See table 6.5.1.2.
eventTime	M,Y	--	See table 6.5.1.2.
notificationType	M,Y	"notifyOccupancyLevelCrossed"	See table 6.5.1.2.
systemDN	C,Y	--	See table 6.5.1.2.
logSubscriptionId	M,Y	Log.logSubscriptionId	See table 6.5.1.2.
currentOccupancyLevel	M,N	The integer portion of $((\text{Log.currentSize} / \text{Log.maxSize}) * 100)$	See clause 5.5.1.
logFullAction	O,N	Log.logFullAction	See clause 5.5.1.

6.6.1.3 Triggering Event

6.6.1.3.1 From-state

logFull OR occupancyLevelCrossed

Assertion Name	Definition
logFull	The log is full, that is, the number of log records contained within the log has exceeded the maximum number of log records that was established at log startup (log capacity has reached 100 %).
occupancyLevelCrossed	The number of log records within the log has crossed one of the threshold boundaries (see 5.5.1 Log.occupancyLevels).

6.6.1.3.2 To-state

logWrapping OR (logHalted OR logging)

Assertion Name	Definition
logWrapping	Applicable for case Log.logFullAction='wrap': The number of log records within the log has exceeded the maximum number of allowed log records (100 % capacity has been crossed). The logging of new records will cause the oldest records within the log to be deleted and replaced (first in, first out). The deletion of records may occur in a block, such that the log transitions back to the "started" state prior to any new records being written.
logHalted	Applicable for case Log.logFullAction='halt': The number of log records within the log has exceeded the maximum number of allowed log records (100 % capacity has been crossed). The logging of new records will be discontinued until the deletion of records has occurred (deletion of records is outside the scope of this IRP).
logging	Applicable for case Log.logFullAction='halt': The number of log records within the log is below the maximum number of allowed records. The generation of the notification is done to inform the subscribed IRP Managers that the log is filling up.

6.6.2 Notification notifyLoggingResumed (O)

6.6.2.1 Definition

Using this notification, an IRPAgent informs all subscribed IRPManagers that the amount of data within a given log has been reduced, allowing logging to resume continue (according to the information provided when the log was created). Note that this notification only applies to Log.logFullAction == 'halt'.

6.6.2.2 Input Parameters

Parameter Name	Qualifier	Matching Information	Comment
objectClass	M,Y	Log.objectClass	See table 6.5.1.2.
objectInstance	M,Y	Log.objectInstance	See table 6.5.1.2.
notificationId	M,N	--	See table 6.5.1.2.
eventTime	M,Y	--	See table 6.5.1.2.
notificationType	M,Y	"notifyLoggingResumed"	See table 6.5.1.2.
systemDN	C,Y	--	See table 6.5.1.2.
logSubscriptionId	M,Y	Log.logSubscriptionId	See table 6.5.1.2.

6.6.2.3 Triggering Event

6.6.2.3.1 From-state

logFull

Assertion Name	Definition
logHalted	The log is full, that is, the number of log records contained within the log has exceeded the maximum number of log records that was established at log startup (log capacity has reached 100 % and Log.logFullAction='halt').
occupancyLevelCrossed	The number of log records within the log has crossed one of the threshold boundaries (see 5.5.1 Log.occupancyLevels).

6.6.2.3.2 To-state

Assertion Name	Definition
logging	The number of log records within the log is below the maximum number of allowed records. The generation of the notification is done to inform the subscribed IRPManagers that the log is filling up.

Annex A (informative): Change history

Change history								
Date	TSG #	TSG Doc.	CR	Rev	Subject/Comment	Cat	Old	New
Mar 2004	S_23	SP-040123	--	--	Submitted to SA#23 for Information	--	1.0.0	
Dec 2004	S_26	SP-040798	--	--	Submitted to SA#26 for Approval	--	2.0.0	6.0.0
Jun 2005	S_28	SP-050290	0001	--	Correct mapping info of currentOccupancyLevel and some editorial errors	F	6.0.0	6.1.0
Jun 2005	S_28	SP-050329	0002	--	Apply Generic System Context – Align with TS 32.150	F	6.0.0	6.1.0
Mar 2006	SA_31	SP-060091	0003	--	Add invocationId output parameter of exportLogRecords operation	F	6.1.0	6.2.0
Mar 2006	SA_31	SP-060089	0004	--	Correct ambiguity of object class and object instance usage in notification	F	6.1.0	6.2.0
Dec 2006	SA_34	SP-060709	0005	--	Correct the errors in the definition of occupancyLevels and currentOccupancyLevel	F	6.2.0	6.3.0
Jun 2007	SA_36	--	--	--	Automatic upgrade to Rel-7 (no CR) at freeze of Rel-7. Deleted reference to CMIP SS, discontinued from R7 onwards.	--	6.3.0	7.0.0
Sep 2007	SA_37	SP-070614	0006	--	Remove the use of visibility symbol	C	7.0.0	8.0.0
Dec 2009	-	-	-	-	Update to Rel-9 version (MCC)	-	8.0.0	9.0.0
Mar 2011	-	-	-	-	Update to Rel-10 version (MCC)	-	9.0.0	10.0.0
2012-09	-	-	-	-	-	Update to Rel-11 version (MCC)	10.0.0	11.0.0