

# 3GPP TS 32.141 V11.1.0 (2013-06)

---

*Technical Specification*

## **3rd Generation Partnership Project; Technical Specification Group Services and System Aspects; Telecommunication management; Subscription Management (SuM) architecture (Release 11)**



The present document has been developed within the 3<sup>rd</sup> Generation Partnership Project (3GPP<sup>TM</sup>) and may be further elaborated for the purposes of 3GPP. The present document has not been subject to any approval process by the 3GPP Organizational Partners and shall not be implemented. This Specification is provided for future development work within 3GPP only. The Organizational Partners accept no liability for any use of this Specification. Specifications and reports for implementation of the 3GPP<sup>TM</sup> system should be obtained via the 3GPP Organizational Partners' Publications Offices.

---

Keywords

---

Subscription Management, Converged  
Management , architecture

**3GPP**

Postal address

---

3GPP support office address

---

650 Route des Lucioles - Sophia Antipolis  
Valbonne - FRANCE  
Tel.: +33 4 92 94 42 00 Fax: +33 4 93 65 47 16

Internet

---

<http://www.3gpp.org>

---

**Copyright Notification**

No part may be reproduced except as authorized by written permission.  
The copyright and the foregoing restriction extend to reproduction in all media.

© 2013, 3GPP Organizational Partners (ARIB, ATIS, CCSA, ETSI, TTA, TTC).  
All rights reserved.

UMTS™ is a Trade Mark of ETSI registered for the benefit of its members  
3GPP™ is a Trade Mark of ETSI registered for the benefit of its Members and of the 3GPP Organizational Partners  
LTE™ is a Trade Mark of ETSI currently being registered for the benefit of its Members and of the 3GPP Organizational Partners  
GSM® and the GSM logo are registered and owned by the GSM Association

---

# Contents

Foreword .....	4
Introduction .....	4
1 Scope .....	5
2 References.....	5
3 Definitions and abbreviations .....	5
3.1 Definitions .....	5
3.2 Abbreviations.....	6
4 Subscription Management (SuM) architecture.....	6
4.1 Functional entities .....	7
4.2 Interfaces.....	8
4.2.1 Application of Itf-N for SuM .....	8
4.2.2 Void .....	8
4.3 Overview of IRP .....	8
4.3.1 IRP security .....	9
4.4 Methodology .....	9
4.4.1 SuM Stage 1 .....	9
4.4.2 SuM Stage 2 .....	9
4.4.3 SuM Stage 3 .....	10
<b>Annex A (informative): Void .....</b>	<b>11</b>
<b>Annex B (informative): Change history.....</b>	<b>12</b>

---

## Foreword

This Technical Specification has been produced by the 3<sup>rd</sup> Generation Partnership Project (3GPP).

The contents of the present document are subject to continuing work within the TSG and may change following formal TSG approval. Should the TSG modify the contents of the present document, it will be re-released by the TSG with an identifying change of release date and an increase in version number as follows:

Version x.y.z

where:

- x the first digit:
  - 1 presented to TSG for information;
  - 2 presented to TSG for approval;
  - 3 or greater indicates TSG approved document under change control.
- y the second digit is incremented for all changes of substance, i.e. technical enhancements, corrections, updates, etc.
- z the third digit is incremented when editorial only changes have been incorporated in the document.

## Ready for Converged Management

This specification is part of a set that has been developed for converged management solutions.

---

## Introduction

The present document is part a TS-family covering the 3<sup>rd</sup> Generation Partnership Project; Technical Specification Group Services and System Aspects; Telecommunication management, as identified below:

- TS 32.140: "Subscription Management (SuM) requirements".
- TS 32.141: "Subscription Management (SuM) architecture".**
- TS 32.171: "Subscription Management (SuM) Network Resource Model (NRM) Integration Reference Point (IRP): Requirements".
- TS 32.172: "Subscription Management (SuM) Network Resource Model (NRM) Integration Reference Point (IRP): Information Service (IS)".
- TS 32.176: "Subscription Management (SuM) Network Resource Model (NRM) Integration Reference Point (IRP); Solution Set (SS) definitions".
- TS 28.751: "Subscription Management (SuM) Network Resource Model (NRM) Integration Reference Point (IRP): Requirements".
- TS 28.752: "Subscription Management (SuM) Network Resource Model (NRM) Integration Reference Point (IRP): Information Service (IS)".
- TS 28.753: "Subscription Management (SuM) Network Resource Model (NRM) Integration Reference Point (IRP); Solution Sets (SS) definitions".

The 3G environment requires more complex service delivery mechanisms and is no longer simply an internal matter for a single operator but a capability that is achieved by linking together features across multiple service providers and

operators. Subscription Management (SuM) is a feature that permits Service Providers, Value Added Service Providers, and Mobile Operators to provision services for a specific subscriber. The feature is necessary to allow service providers and operators to provision, control, monitor and bill the configuration of services that they offer to their subscribers.

For further details see 3GPP TS 32.140 [5] on SuM requirements that gives an overview of SuM.

---

# 1 Scope

The present document defines the architecture for Subscription Management (SuM) , including Converged Management of fixed and mobile networks.

---

# 2 References

The following documents contain provisions which, through reference in this text, constitute provisions of the present document.

- References are either specific (identified by date of publication, edition number, version number, etc.) or non-specific.
- For a specific reference, subsequent revisions do not apply.
- For a non-specific reference, the latest version applies. In the case of a reference to a 3GPP document (including a GSM document), a non-specific reference implicitly refers to the latest version of that document *in the same Release as the present document*.

- [1] 3GPP TR 21.905: "Vocabulary for 3GPP Specifications".
- [2] 3GPP TS 23.002: "Network Architecture".
- [3] 3GPP TS 32.101: "Telecommunication management; Principles and high level requirements".
- [4] 3GPP TS 32.102: "Telecommunication management; Architecture".
- [5] 3GPP TS 32.140: "Telecommunication management; Subscription Management (SuM) requirements".
- [6] 3GPP TS 23.008: "Organization of subscriber data".
- [7] 3GPP TS 32.150: "Integration Reference Point (IRP) Concept and definitions".

---

# 3 Definitions and abbreviations

## 3.1 Definitions

For the purposes of the present document, the following terms and definitions apply:

**subscriber:** See 3GPP TR 21.905 [1].

**service:** See 3GPP TR 21.905 [1].

**Integration Reference Point (IRP):** See 3GPP TS 32.101 [3].

**user:** See 3GPP TR 21.905 [1].

**subscription:** See 3GPP TR 21.905 [1].

**Subscription Management (SuM):** See 3GPP TR 32.140 [5].

**Subscription Profile:** See 3GPP TR 32.140 [5].

**Subscription Profile Component:** See 3GPP TR 32.140 [5].

## 3.2 Abbreviations

For the purposes of the present document, the following abbreviations apply:

2G	Second Generation Mobile
3G	Third Generation Mobile
API	Application Programming Interface
ASP	Application Service Provider
AuC	Authentication Center
B2B	Business to Business
CS	Circuit Switch
EIR	Equipment Identity Register
GTT	Global Text Telephony
GUP	Generic User Profile
HE	Home Environment
HLR	Home Location Register
HSS	Home Subscriber Server
IMS	IP Multimedia Subsystem
IRP	Integration Reference Point (3GPP TS 32.102 [4])
ISP	Internet Service Provider
NPDB	Number Portability Data Base
NRM	Network Resource Model
OAM	Operations, Administration and Maintenance
OSA	Open Services Access
OSF	Operations System Functions
OSS	Operations Support System
PS	Packet Switch
SLA	Service Level Agreement
SM&O	Service Management and Operations (TMF/ITU-T)
SP	Service Provider
SuM	Subscription Management
TMN	Telecommunication Management Network
TR-IRP	Trading Partner IRP
UICC	Universal Integrated Circuit Card
USIM	Universal Subscriber Identity Module
VASP	Value Added Service Provider
VHE	Virtual Home Environment
VNO	Virtual Network Operator

---

## 4 Subscription Management (SuM) architecture

3G Telecommunication Management focuses on the most important and strategic contexts in the physical architecture for the management of UMTS. The framework to help define a telecom management physical architecture for a planned UMTS and to adopt standards and provide products that are easy to integrate is defined in 3GPP TS 32.102 [4].

SuM manages Subscription Profile Components stored in network resources for the purpose of providing services to specific subscribers. This is done with an architecture that is consistent with the one specified in 3GPP TS 32.102 [4].

Subscription Profiles represent services and are associated to subscribers that employ these services (3GPP TS 32.140 [5]). To the extent the HSS controls certain services, Subscription Profile Components can be associated with the HSS. Other services, and as a result Subscription Profiles Components, are outside the jurisdiction of the HSS.

## 4.1 Functional entities

Functional entities belonging to SuM are described in Figure 1. The figure also contains the actors related to Subscriptions.

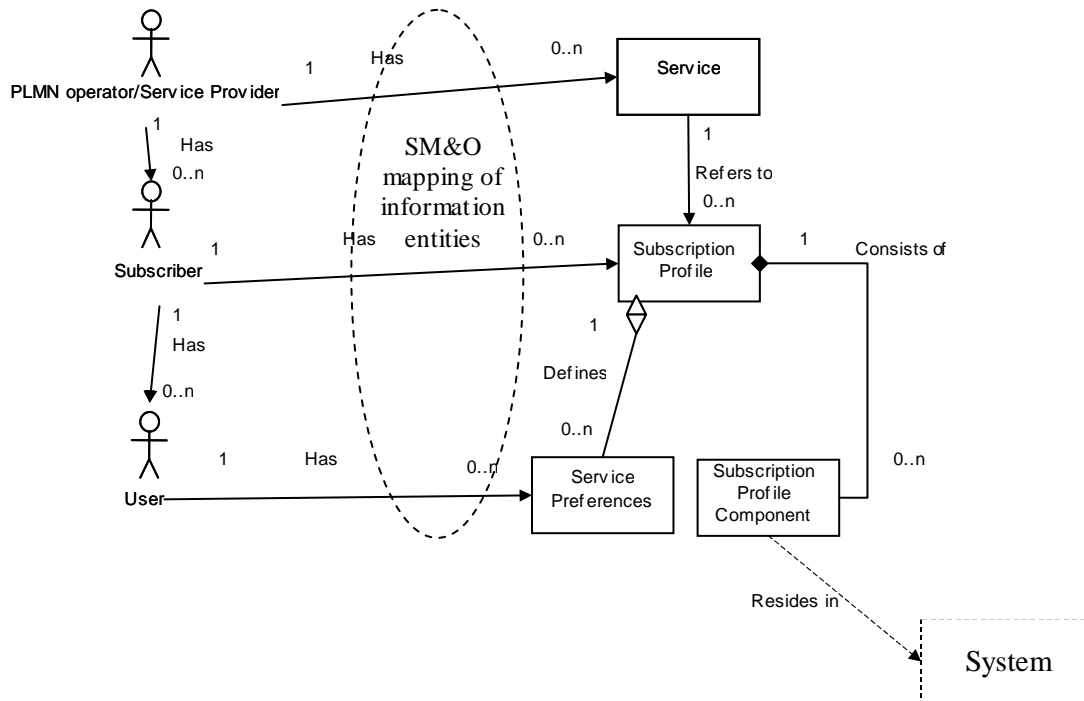

**Figure 1: Functional entities in SUM**

Actors described in Figure 1 are:

- **Subscriber** (definition See TS 21.905)
- **User** (definition See TS 21.905)
- **Service Provider** (definition See TS 21.905)
- **PLMN Operator** (definition See TS 21.905)

The entities described in Figure 1 are:

- **Subscription Profile** (definition See TS 32.140)
- **Subscription Profile Component** (definition See TS 32.140)
- **Service** (definition See TS 21.905)
- **System** (definition See TS 32.102)
- **Service Preferences**: Contains the service preferences chosen for a user. Each user configures his preferences for a particular subscribed service, but only within the limits defined by the Subscription.

### Clarifications to the figure:

- A PLMN Operator/Service Provider has one or several Services to offer for Subscribers.
- A Subscriber has one or several Subscription Profiles, where each describes an offered Service.
- A User has one or several Service Preferences, where each describes the user's chosen preferences for the service.



- A Subscription Profile may consist of one or several Subscription Profile Components.
- A Subscription Profile may define one or several Service Preferences.
- A Subscription Profile Component resides in one or several systems
- Subscriptions are managed in the form of Subscription profile components, which may be distributed across Service Management & Operations (SM&O), Network Resource Management & Operations (RM&O) and Network Domains. There may also be mappings among the SM&O, RM&O and Network Domains.

## 4.2 Interfaces

### 4.2.1 Application of Itf-N for SuM

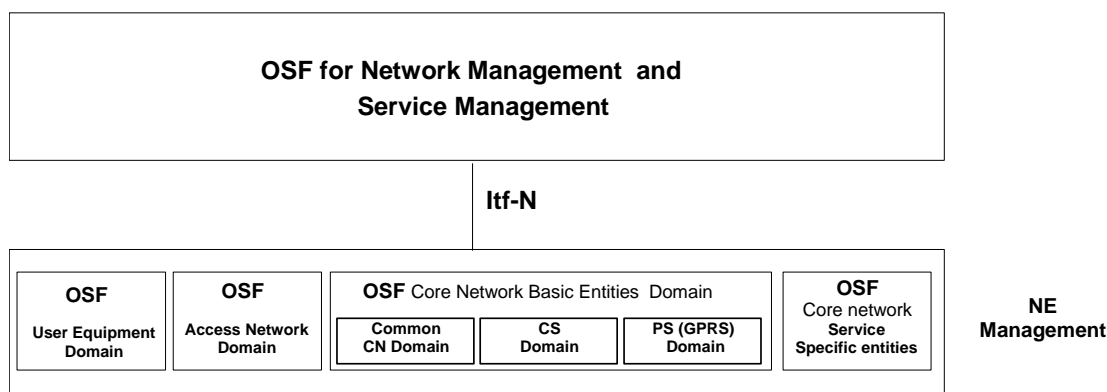

**Figure 2: Overview of PLMN Telecom Management Domains and Itf-N (3GPP TS 32.102 [4])**

The Itf-N for SuM is realized by means of an Integration Reference Point (IRP) as defined in 3GPP TS 32.102 [4].

Operations System Functions (OSF) functionality can be realized in NEs or in the NE Management systems. SuM, for this release, is concerned with the OSF functionality contained in the Core Network Basic Entities Domain and specifically that of the Common CN Domain. Subscription Profile Components are located in the NEs OSF's within the Common CN Domain or their NEs OSF's in the NE management systems, and are in either case accessed consistent with the IRP concept. SuM OSF's for Network Management and Service Management are located in network- and service management systems.

### 4.2.2 Void

## 4.3 Overview of IRP

Figures 3 and 4 identify system contexts of the IRP in terms of its implementation, called IRPAgent (see 3GPP TS 32.150 [7]), and the user of the IRPAgent, called IRPManager (see 3GPP TS 32.150 [7]).

The IRPAgent implements and supports the Interface IRPs for SuM NRM IRP. The IRPAgent can reside in an Element Manager (EM) or a Network Element (NE) (3GPP TS 32.102 [4]). In the former case, the interface (represented by a thick dotted line) between the EM and the NEs is not the subject of the Interface IRPs for SuM NRM IRP.

An IRPManager using the Interface IRPs for SuM NRM IRP shall choose one of the two System Contexts defined here, for each NE. For instance, if an EM is responsible for managing a number of NEs, the NM shall access the Interface IRPs for SuM NRM IRP through the EM and not directly to those NEs.

The interface IRPs for SuM NRM IRP can be the following:

- Basic CM IRP

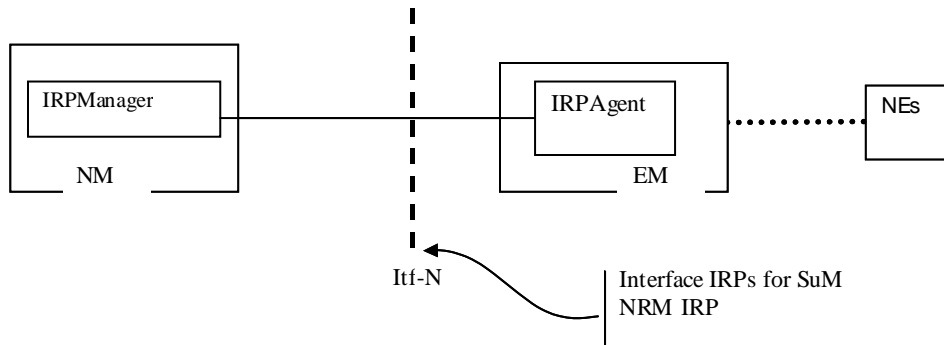

**Figure 3: System Context A**

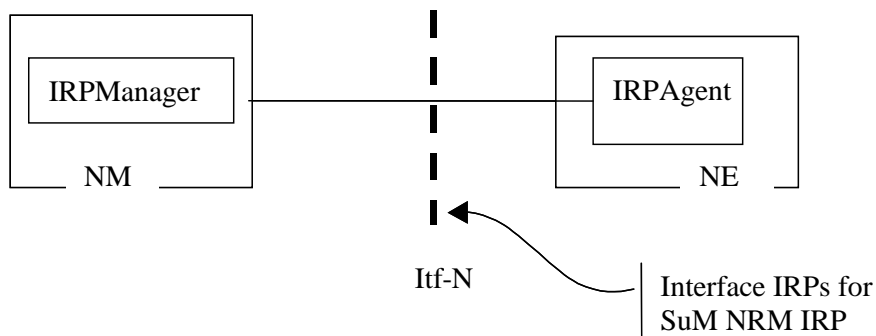

**Figure 4: System Context B**

### 4.3.1 IRP security

The IRP interface is made secure by controlling access to the network and management systems. Operations processes must insure that only authorized personnel have the access authority to retrieve and alter SuM data. Standard protocols used over the interface between the IRPManager and the IRPAgent provide some degree of security. The exact nature of the security is described in the Solution Set for that protocol. In addition to the requirement that the IRPManager and the IRPAgent be secure, most physical links between them are secured as well.

## 4.4 Methodology

The methodology used to conclude the standard work for SuM shall follow the IRP methodology described in 3GPP TS 32.150 [4]. This subclause describes how to apply that methodology.

### 4.4.1 SuM Stage 1

SuM Stage 1 is documented in 3GPP TS 32.140 [5].

### 4.4.2 SuM Stage 2

SuM Stage 2 is documented as follows:

- a) The present document (3GPP TS 32.141) is finalized by identifying the relevant IRPs.
- b) 3GPP TS 32.171 (for non-converged management) and TS 28.751 (for converged management) define the Requirements for the SuM NRM IRP.  
3GPP TS 32.171 and TS 28.751 shall, where applicable, follow the structure in 3GPP TS 32.621 (for non-converged management) and TS 28.621 (for converged management) (Generic NRM IRP: Requirements), respectively.
- c) 3GPP TS 32.172 (for non-converged management) and TS 28.752 (for converged management) describe the Information Service for the SuM NRM IRP – containing the Information Object Classes (IOCs), attributes,

relations etc. for SuM.

3GPP TS 32.172 and TS 28.752 shall, where applicable, follow the structure in 3GPP TS 32.622 (for non-converged management) and TS 28.622 (for converged management) (Generic NRM IRP: Information Service) , respectively.

### 4.4.3 SuM Stage 3

SuM Stage 3 is documented in the following documents:

- TS 32.176 (for non-converged management) and TS 28.623 (for converged management) SuM NRM IRP: Solution Set definitions.

---

## Annex A (informative): Void

## Annex B (informative): Change history

Change history							
Date	TSG #	TSG Doc.	CR	Rev	Subject/Comment	Old	New
Mar 2003	SA_19	SP-030042	--	--	Submitted to SA#19 as v1.0.0 for Information	1.0.0	--
Sep 2003	SA_21	SP-030405	--	--	Submitted to SA#21 as v2.0.0 for Approval	2.0.0	6.0.0
Mar 2004	SA_23	SP-040108	0001	--	Subscription Management TS-family (32.14x and 32.17x) title alignment ("SM" becomes "SuM" and delete "Services operations management")	6.0.0	6.1.0
Jun 2007	SA_36	--	--	--	Automatic upgrade to Rel-7 (no CR) at freeze of Rel-7.	6.1.0	7.0.0
Dec 2008	SA_42	--	--	--	Upgrade to Release 8	7.0.0	8.0.0
Sep 2009	SA_45	SP-090627	0002	--	Align with TS 32.140 SuM requirements	8.0.0	9.0.0
Mar 2011	-	-	-	-	Update to Rel-10 version (MCC)	9.0.0	10.0.0
2012-09	-	-	-	-	Update to Rel-11 version (MCC)	10.0.0	<b>11.0.0</b>
2013-06	SA_60	Sp-130304	0003	2	SuM Arch	11.0.0	<b>11.1.0</b>