

3GPP TS 32.111-6 V11.0.0 (2012-09)

Technical Specification

**3rd Generation Partnership Project;
Technical Specification Group Services and System Aspects;
Telecommunication management;
Fault Management;
Part 6: Alarm Integration Reference Point (IRP):
Solution Set (SS) definitions
(Release 11)**



Keywords

UMTS, Log Management, Alarm Management,
CORBA, XML, SOAP

3GPP

Postal address

3GPP support office address

650 Route des Lucioles - Sophia Antipolis
Valbonne - FRANCE
Tel.: +33 4 92 94 42 00 Fax: +33 4 93 65 47 16

Internet

<http://www.3gpp.org>

Copyright Notification

No part may be reproduced except as authorized by written permission.
The copyright and the foregoing restriction extend to reproduction in all media.

© 2012, 3GPP Organizational Partners (ARIB, ATIS, CCSA, ETSI, TTA, TTC).
All rights reserved.

UMTS™ is a Trade Mark of ETSI registered for the benefit of its members
3GPP™ is a Trade Mark of ETSI registered for the benefit of its Members and of the 3GPP Organizational Partners
LTE™ is a Trade Mark of ETSI currently being registered for the benefit of its Members and of the 3GPP Organizational Partners
GSM® and the GSM logo are registered and owned by the GSM Association

Contents

Foreword	5
Introduction	5
1 Scope	6
2 References.....	6
3 Definitions and abbreviations	7
3.1 Definitions	7
3.2 Abbreviations.....	7
4 Solution Set Definitions	7
Annex A (normative): CORBA Solution Set.....	9
A.1 Architectural Features	9
A.1.1 Syntax for Distinguished Names	9
A.1.2 Notification Services.....	9
A.1.3 Push and Pull Style.....	9
A.1.4 Support multiple notifications in one push operation	9
A.1.5 AlarmIRPNotifications Interface	9
A.1.5.1 Method push (M)	9
A.1.6 Filter.....	10
A.2 Mapping.....	10
A.2.1 Operation and Notification mapping	10
A.2.2 Operation parameter mapping	11
A.2.3 Notification parameter mapping	18
A.3 Solution Set definitions	26
A.3.1 IDL definition structure.....	26
A.3.2 IDL specification "AlarmIRPConstDefs.idl"	26
A.3.3 IDL specification "AlarmIRPSystem.idl"	34
A.3.4 IDL specification "AlarmIRPNotifications.idl"	36
Annex B (normative): XML Definitions	41
B.1 Architectural Features	41
B.1.1 Syntax for Distinguished Names	41
B.1.2 Notification Services.....	41
B.1.3 IOC Definitions.....	41
B.2 Mapping.....	41
B.3 Solution Set definitions	41
B.3.1 XML definition structure	41
B.3.2 Graphical Representation.....	42
B.3.3 XML Schema "alarmIRPNotif.xsd"	47
B.3.4 XML Schema "alarmIRPIOCs.xsd"	50
Annex C (normative): SOAP Solution Set.....	57
C.1 Architectural features.....	57
C.1.1 Syntax for Distinguished Names	57
C.1.2 Notification Services.....	57
C.1.3 Supported W3C specifications	57
C.1.4 Prefixes and namespaces.....	57
C.2 Mapping.....	58
C.2.1 Operation and notification mapping	58
C.2.2 Operation parameter mapping	58

C.2.2.1	Operation acknowledgeAlarms	59
C.2.2.1.1	Input parameters	59
C.2.2.1.2	Output parameters	59
C.2.2.1.3	Fault definition	59
C.2.2.2	Operation getAlarmList	59
C.2.2.2.1	Input parameters	59
C.2.2.2.2	Output parameters	60
C.2.2.2.3	Fault definition	60
C.2.2.3	Operation getAlarmCount	60
C.2.2.3.1	Input parameters	60
C.2.2.3.2	Output parameters	60
C.2.2.3.3	Fault definition	61
C.2.2.4	Operation unacknowledgeAlarms	61
C.2.2.4.1	Input parameters	61
C.2.2.4.2	Output parameters	61
C.2.2.4.3	Fault definition	61
C.2.2.5	Operation setComment	62
C.2.2.5.1	Input parameters	62
C.2.2.5.2	Output parameters	62
C.2.2.5.3	Fault definition	62
C.2.2.6	Operation clearAlarms	62
C.2.2.6.1	Input parameters	62
C.2.2.6.2	Output parameters	63
C.2.2.6.3	Fault definition	63
C.3	Solution Set definitions	64
C.3.1	WSDL definition structure.....	64
C.3.2	Graphical Representation.....	64
C.3.3	WSDL specification “AlarmIRPSystem.wsdl”	65
Annex D (informative):	Change history.....	72

Foreword

This Technical Specification has been produced by the 3rd Generation Partnership Project (3GPP).

The contents of the present document are subject to continuing work within the TSG and may change following formal TSG approval. Should the TSG modify the contents of the present document, it will be re-released by the TSG with an identifying change of release date and an increase in version number as follows:

Version x.y.z

where:

- x the first digit:
 - 1 presented to TSG for information;
 - 2 presented to TSG for approval;
 - 3 or greater indicates TSG approved document under change control.
- y the second digit is incremented for all changes of substance, i.e. technical enhancements, corrections, updates, etc.
- z the third digit is incremented when editorial only changes have been incorporated in the document.

Introduction

The present document is part of a TS-family covering the 3rd Generation Partnership Project: Technical Specification Group Services and System Aspects; Telecommunication management; as identified below:

- 32.111-1 "Fault Management; Part 1: 3G fault management requirements".
- 32.111-2 "Fault Management; Part 2: Alarm Integration Reference Point (IRP): Information Service (IS)".
- 32.111-6 "Fault Management; Alarm Integration Reference Point (IRP); Solution Set (SS) definitions".**

The present document is part of a TS-family, which describes the requirements and information model necessary for Telecommunications Management (TM). The TM principles and TM architecture are specified in 3GPP TS 32.101 [1] and 3GPP TS 32.102 [2].

A communications system is composed of a multitude of Network Elements (NE) of various types and, typically, different vendors, which inter-operate in a coordinated manner in order to satisfy the network users' communication requirements.

The occurrence of faults in an NE may cause deterioration or loss of this NE's function. Fault Management is the functional area, which allows the operator to detect the occurrence of faults in the network in real-time. Configuration Management and Performance Management are two more functional areas, which require the operator to be alerted to certain conditions in the network.

A standard general-purpose mechanism for the management of logs containing selected notifications from the network is required to provide an ability to perform historical analysis on faults and conditions, which occurred in the network. The TS 32.33x-series, constituting the Notification Log IRP, sets forth such a mechanism - and Annex B of the present document contains the XML definition related to Alarm IRP notifications.

1 Scope

The present document contains the Solution Sets for the IRP whose semantics is specified in Alarm IRP: Information Service (TS 32.111-2 [4]).

These Solution Set specifications are related to 3GPP TS 32.111-2 V11.0.X.

2 References

The following documents contain provisions which, through reference in this text, constitute provisions of the present document.

- References are either specific (identified by date of publication, edition number, version number, etc.) or non-specific.
- For a specific reference, subsequent revisions do not apply.
- For a non-specific reference, the latest version applies. In the case of a reference to a 3GPP document (including a GSM document), a non-specific reference implicitly refers to the latest version of that document *in the same Release as the present document*.

- [1] 3GPP TS 32.101: "Telecommunication management; Principles and high level requirements".
- [2] 3GPP TS 32.102: "Telecommunication management; Architecture".
- [3] 3GPP TS 32.111-1: "Telecommunication management; Fault Management; Part 1: 3G fault management requirements".
- [4] 3GPP TS 32.111-2: "Telecommunication management; Fault Management; Part 2: Alarm Integration Reference Point: Information Service (IS)".
- [5] 3GPP TS 32.150: "Telecommunication management; Integration Reference Point (IRP) Concept and definitions".
- [6] 3GPP TS 32.300: "Telecommunication management; Configuration Management (CM); Name convention for Managed Objects".
- [7] 3GPP TS 32.302: "Telecommunication management; Configuration Management (CM); Notification Integration Reference Point (IRP): Information Service (IS)".
- [8] 3GPP TS 32.306: "Telecommunication management; Configuration Management (CM); Notification Integration Reference Point (IRP): Solution Set (SS) definitions".
- [9] 3GPP TS 32.311: "Telecommunication management; Generic Integration Reference Point (IRP) management; Requirements".
- [10] 3GPP TS 32.312: "Telecommunication management; Generic Integration Reference Point (IRP) management; Information Service (IS)".
- [11] 3GPP TS 32.316: "Telecommunication management; Generic Integration Reference Point (IRP) management: Solution Set (SS) definitions".
- [12] 3GPP TS 32.331: "Telecommunication management; Notification Log (NL) Integration Reference Point (IRP): Requirements".
- [13] 3GPP TS 32.336: "Telecommunication management; Notification Log (NL) Integration Reference Point (IRP): Solution Set (SS) definitions".
- [14] OMG TC Document telecom/98-11-01: "OMG Notification Service".
<http://www.omg.org/technology/documents/>
- [15] OMG CORBA Services: "Common Object Services Specification, Update: November 22, 1996" (Clause 4 contains the Event Service specification). <http://www.omg.org/technology/documents/>

- [16] W3C SOAP 1.1 specification (<http://www.w3.org/TR/2000/NOTE-SOAP-20000508/>)
- [17] W3C SOAP 1.2 specification (<http://www.w3.org/TR/soap12-part1/>)
- [18] W3C WSDL 1.1 specification (<http://www.w3.org/TR/2001/NOTE-wsdl-20010315>)
- [19] W3C XPath 1.0 specification (<http://www.w3.org/TR/1999/REC-xpath-19991116>)

3 Definitions and abbreviations

3.1 Definitions

For the purposes of the present document, the terms and definitions given in 3GPP TS 32.101 [1], 3GPP TS 32.102 [2], 3GPP TS 32.111-1 [3], 3GPP TS 32.111-2 [4], 3GPP TS 32.150 [5] and 3GPP TS 32.331 [12] apply.

IRP document version number string

The IRP document version number (sometimes called “IRP version” or “version number”) string is used to identify the present document. The definition of “IRP document version number string” in 3GPP TS 32.311 [9] provides the rule to derive such a string.

This string is used for the return value of `get_alarm_irp_versions()`. It is used as return value of `get_notification_categories()` if the Notification IRP supports the emission of notifications defined by this Alarm IRP version. It is also used in the `domain_name` attribute of a structured event carrying alarm information defined by this Alarm IRP version.

3.2 Abbreviations

For the purposes of the present document, the following abbreviations apply:

CORBA	Common Object Request Broker Architecture
IDL	Interface Definition Language
IRP	Integration Reference Point
IS	Information Service
MOC	Managed Object Class
MOI	Managed Object Instance
NE	Network Element
NL	Notification Log
OMG	Object Management Group
SS	Solution Set
TMN	Telecommunications Management Network
UML	Unified Modelling Language
WSDL	Web Service Description Language
XML	eXtensible Markup Language

4 Solution Set Definitions

This specification defines the following 3GPP Alarm IRP Solution Set Definitions:

- Annex A provides the CORBA Solution Set.
- Annex B provides the XML Definitions.
- Annex C provides the SOAP Solution Set.

Annex A (normative): CORBA Solution Set

This annex contains the CORBA Solution Set for the IRP whose semantics is specified in Alarm IRP: Information Service (TS 32.111-2 [4]).

A.1 Architectural Features

The overall architectural feature of Alarm IRP is specified in 3G TS 32.111-2 [4]. This clause specifies features that are specific to the CORBA SS.

A.1.1 Syntax for Distinguished Names

The syntax of a Distinguished Name is defined in 3GPP TS 32.300 [6].

A.1.2 Notification Services

In implementations of CORBA SS, IRPAgent conveys Alarm Information to IRPManager via OMG Notification Service (OMG Notification Service [14]).

OMG Event Service [15] provides event routing and distribution capabilities. OMG Notification Service provides, in addition to Event Service, event filtering and Quality Of Service (QOS) as well.

A necessary and sufficient sub set of OMG Notification Services shall be used to support AlarmIRPNotifications notifications as specified in 3G TS 32.111-2 [4].

A.1.3 Push and Pull Style

OMG Notification Service defines two styles of interaction. One is called push style. In this style, IRPAgent pushes notifications to IRPManager as soon as they are available. The other is called pull style. In this style, IRPAgent keeps the notifications till IRPManager requests for them.

This CORBA SS specifies that support of Push style is Mandatory (M) and that support of Pull style is Optional (O).

A.1.4 Support multiple notifications in one push operation

For efficiency reasons, IRPAgent may send multiple notifications using one single push operation. To pack multiple notifications into one push operation, IRPAgent may wait and not invoke the push operation as soon as notifications are available. To avoid IRPAgent to wait for an extended period of time that is objectionable to IRPManager, IRPAgent shall implement an IRPAgent wide timer configurable by administrator. On expiration of this timer, IRPAgent shall invoke push if there is at least one notification to be conveyed to IRPManager. This timer is re-started after each push invocation.

A.1.5 AlarmIRPNotifications Interface

OMG CORBA Notification push operation is used to realise the notification of AlarmIRPNotifications. All the notifications in this interface are implemented using this push_structured_event method.

A.1.5.1 Method push (M)

```
module CosNotifyComm {
...
Interface SequencePushConsumer : NotifyPublish {
void push_structured_events(
in CosNotification::EventBatch notifications)
```

```

        raises ( CosEventComm : Disconnected );
...
}; // SequencePushConsumer
...
}; // CosNotifyComm

```

NOTE 1: The `push_structured_events` method takes an input parameter of type `EventBatch` as defined in the `OMG CosNotification` module (OMG Notification Service [14]). This data type is the same as a sequence of Structured Events. Upon invocation, this parameter will contain a sequence of Structured Events being delivered to IRPManager by IRPAgent to which it is connected.

NOTE 2: The maximum number of events that will be transmitted within a single invocation of this operation is controlled by IRPAgent wide configuration parameter.

NOTE 3: The amount of time the supplier (IRPAgent) of a sequence of Structured Events will accumulate individual events into the sequence before invoking this operation is controlled by IRPAgent wide configuration parameter as well.

NOTE 4: IRPAgent may push `EventBatch` with only one Structured Event.

A.1.6 Filter

IRPAgent shall optionally support alarm filtering based on IRPManager's supplied alarm filter constraints (e.g. as parameter in `subscribe()` of 3G TS 32.302 [7]). Alarm filtering can be applied in the following cases:

- It is applicable to alarms emitted by IRPAgent via `AlarmIRPNotifications`. IRPManager supplies alarm filter constraint via the `subscribe` method. This filter is effective during the period of subscription.
- It is applicable to alarms returned by IRPAgent via the `out` parameter of `get_alarm_list` method. IRPManager supplies alarm filter constraint via the `get_alarm_list` method. This filter is effective only for this method invocation.
- It is applicable to the calculation of alarm counts returned by IRPAgent via the `out` parameters of `get_alarm_count` method. IRPManager supplies alarm filter constraint via the `get_alarm_count` method. This filter is effective only for this method invocation.

This SS shall use of filter constraint grammar specified by reference `OMG Notification Service` [14]. The name of the grammar is called "EXTENDED_TCL". See clause 2.4, Default Filter Constraint Language in `OMG Notification Service` [14]. This SS shall use this grammar only.

A.2 Mapping

A.2.1 Operation and Notification mapping

Alarm IRP: IS 3G TS 32.111-2 [4] defines semantics of operation and notification visible across the Alarm IRP. Table A.2.1.1 indicates mapping of these operations and notifications to their equivalents defined in this SS.

Table A.2.1.1: Mapping from IS Notification/Operation to SS equivalents

IS Operation/ notification 3G TS 32.111-2 [4]	SS Method	Qualifier
<code>acknowledgeAlarms</code>	<code>acknowledge_alarms</code>	M
<code>unacknowledgeAlarms</code>	<code>unacknowledge_alarms</code>	O
<code>getAlarmList</code>	<code>get_alarm_list</code>	M
<code>getIRPVersion</code> (note)	<code>get_alarm_irp_versions</code>	M

getAlarmCount	get_alam_count	O
setComment	comment_alarms	O
clearAlarms	clear_alarms	O
getOperationProfile (note)	get_alam_irp_operations_profile	O
getNotificationProfile (note)	get_alam_irp_notification_profile	O
notifyNewAlarm	push_structured_event Note that OMG Notification Service OMG Notification Service [14] defines this method. See clause A.3.1	M
notifyClearedAlarm	push_structured_event See clause A.3.1	M
notifyChangedAlarm	push_structured_event See clause A.3.1	M
notifyAckStateChanged	push_structured_event See clause A.3.1	M
notifyAlarmListRebuilt	push_structured_event See clause A.3.1	M
notifyComments	push_structured_event See clause A.3.1	O
notifyPotentialFaultyAlarmList	push_structured_event See clause A.3.1	O
notifyCorrelatedNotificationChanged	push_structured_event See clause A.3.1	O
NOTE: This operation is of ManagedGenericIRP IOC specified in [10]. The AlarmIRP IOC of [4] inherits from it.		

A.2.2 Operation parameter mapping

Reference 3G TS 32.111-2 [4] defines semantics of parameters carried in operations across the Alarm IRP. The following set of tables indicates the mapping of these parameters, as per operation, to their equivalents defined in this SS.

Table A.2.2.1: Mapping from IS acknowledgeAlarms parameters to SS equivalents

IS Operation parameter	SS Method parameter	Qualifier
alarmInformationAndSeverityReferenceList	AlarmIRPConstDefs::AlarmInformationIdAndSevSeq alarm_information_id_and_sev_list Note: perceivedSeverity is optional { alarmId - Mandatory; perceivedSeverity - Optional }	M
ackUserId	string ack_user_id	M
ackSystemId	ManagedGenericIRPConstDefs::StringOpt ack_system_id	O
badAlarmInformationReferenceList	AlarmIRPConstDefs::BadAcknowledgeAlarmInfoSeq bad_ack_alam_info_list	M
status	ManagedGenericIRPConstDefs::Signal Exceptions: AcknowledgeAlarms, ManagedGenericIRPSystem::ParameterNotSupported, ManagedGenericIRPSystem::InvalidParameter	M

Table A.2.2.2: Mapping from IS unacknowledgeAlarms parameters to SS equivalents

IS Operation parameter	SS Method parameter	Qualifier
alarmInformationReferenceList	AlarmIRPCConstDefs::AlarmInformationIdSeq alarm_information_id_list	M
ackUserId	string ack_user_id	M
ackSystemId	ManagedGenericIRPCConstDefs::StringOpt ack_system_id	O
badAlarmInformationReferenceList	AlarmIRPCConstDefs::BadAlarmInformationIdSeq bad_alarm_information_id_list	M
status	ManagedGenericIRPCConstDefs::Signal Exceptions: UnacknowledgeAlarms, ManagedGenericIRPSystem::OperationNotSupported, ManagedGenericIRPSystem::ParameterNotSupported, ManagedGenericIRPSystem::InvalidParameter	M

Table A.2.2.3: Mapping from IS getAlarmList parameters to SS equivalents

IS Operation parameter	SS Method parameter	Qualifier
alarmAckState, filter	ManagedGenericIRPCConstDefs::StringOpt filter	O
baseObjectClass, baseObjectInstance	AlarmIRPCConstDefs::DNOpt base_object	O (Note 1)
alarmInformationList	Return value of type AlarmIRPCConstDefs::AlarmInformationSeq (Note 2)	M
status	Exceptions: GetAlarmList, FilterComplexityLimit, ManagedGenericIRPSystem::ParameterNotSupported, ManagedGenericIRPSystem::InvalidParameter	M
Note 1:	If notification notifyAlarmListRebuilt supports indicating that only a part of the alarm list has been rebuilt then this parameter shall be supported.	
Note 2:	Each Structured Event of AlarmIRPCConstDefs::AlarmInformationSeq shall have the fields defined in Table A.2.2.4 or Table A.2.2.5.	

Table A.2.2.4: Definition of a Structured Event of AlarmIRPConstDefs::AlarmInformationSeq for alarms not related to security

IS Parameters	OMG CORBA Structured Event attribute	Qualifier	Comment
There is no corresponding IS attribute.	domain_name		
notificationType	type_name	M	The parameter carries <ul style="list-style-type: none"> NOTIFY_FM_NEW_ALARM of interface NotificationType of module AlarmIRPConstDefs in case the alarm has not yet changed and has not yet been cleared. NOTIFY_FM_CHANGED_ALARM of interface NotificationType of module AlarmIRPConstDefs in case the alarm has changed but has not yet been cleared. NOTIFY_FM_CLEARED_ALARM of interface NotificationType of module AlarmIRPConstDefs in case the alarm has been cleared but not yet acknowledged.
alamType	See Table A.2.3.1	M	See Table A.2.3.1
There is no corresponding SS attribute.	variable Header		
objectClass, objectInstance	See Table A.2.3.1	M	See Table A.2.3.1
notificationId	See Table A.2.3.1	M	See Table A.2.3.1
eventTime	See Table A.2.3.1	O	Value of NV pair is a IRPTime of module ManagedGenericIRPConstDefs. The parameter carries the <ul style="list-style-type: none"> alamRaisedTime in case notificationType carries NOTIFY_FM_NEW_ALARM alamChangedTime in case notificationType carries NOTIFY_FM_CHANGED_ALARM alamClearedTime in case notificationType carries NOTIFY_FM_CLEARED_ALARM
systemDN	See Table A.2.3.1	M	See Table A.2.3.1
alamId	See Table A.2.3.1	M	See Table A.2.3.1
alamRaisedTime	One NV pair of filterable_body_fields	M	Name of NV pair is the ALARM_RAISED_TIME of interface AttributeNameValue of module AlarmIRPConstDefs. Value of NV pair is a IRPTime of module ManagedGenericIRPConstDefs.
alamChangedTime	One NV pair of filterable_body_fields	O	Name of NV pair is the ALARM_CHANGED_TIME of interface AttributeNameValue of module AlarmIRPConstDefs. Value of NV pair is a IRPTime of module ManagedGenericIRPConstDefs.
alamClearedTime	One NV pair of filterable_body_fields	M	present if related alarm was cleared; not present if related alarm was not cleared Name of NV pair is the ALARM_CLEARED_TIME of interface AttributeNameValue of module AlarmIRPConstDefs. Value of NV pair is a IRPTime of module ManagedGenericIRPConstDefs.
probableCause	See Table A.2.3.1	M	See Table A.2.3.1
perceivedSeverity	See Table A.2.3.1	M	See Table A.2.3.1
rootCauseIndicator	See Table A.2.3.1	O	See Table A.2.3.1
specificProblem	See Table A.2.3.1	O	See Table A.2.3.1
backedUpStatus	See Table A.2.3.1	O	See Table A.2.3.1
trendIndication	See Table A.2.3.1	O	See Table A.2.3.1
thresholdInfo	See Table A.2.3.1	O	See Table A.2.3.1
stateChangeDefinition	See Table A.2.3.1	O	See Table A.2.3.1
monitoredAttributes	See Table A.2.3.1	O	See Table A.2.3.1
proposedRepairActions	See Table A.2.3.1	O	See Table A.2.3.1

IS Parameters	OMG CORBA Structured Event attribute	Qualifier	Comment
additionalText	See Table A.2.3.1	O	See Table A.2.3.1
additionalInformation	See Table A.2.3.1	O	See Table A.2.3.1
ackTime	See Table A.2.3.3	M	present if related alarm was acknowledged or unacknowledged; not present if related alarm was not acknowledged or unacknowledged See Table A.2.3.3
ackUserId	See Table A.2.3.3	M	present if related alarm was acknowledged or unacknowledged; not present if related alarm was not acknowledged or unacknowledged See Table A.2.3.3
ackSystemId	See Table A.2.3.3	O	optionally present if related alarm was acknowledged or unacknowledged; not present if related alarm was not acknowledged or unacknowledged See Table A.2.3.3
ackState	See Table A.2.3.3	M	present if related alarm was acknowledged or unacknowledged; not present if related alarm was not acknowledged or unacknowledged See Table A.2.3.3
clearUserId	See Table A.2.3.4	O	optionally present if related alarm was cleared; not present if related alarm was not cleared See Table A.2.3.4
clearSystemId	See Table A.2.3.4	O	optionally present if related alarm was cleared; not present if related alarm was not cleared See Table A.2.3.4
backUpObject	See Table A.2.3.1	O	See Table A.2.3.1
correlatedNotifications	See Table A.2.3.1	O	See Table A.2.3.1
comments	See Table A.2.3.7	M	present if related alarm was commented; not present if related alarm was not commented See Table A.2.3.7
There is no corresponding IS attribute.	remaining_ body		

Table A.2.2.5: Definition of a Structured Event of AlarmIRPConstDefs::AlarmInformationSeq for alarms related to security

IS Parameters	OMG CORBA Structured Event attribute	Qualifier	Comment
There is no corresponding IS attribute.	domain_name		
notificationType	type_name	M	See Table A.2.3.1 The parameter carries <ul style="list-style-type: none"> NOTIFY_FM_NEW_ALARM of interface NotificationType of module AlarmIRPConstDefs in case the alarm has not yet changed and has not yet been cleared. NOTIFY_FM_CHANGED_ALARM of interface NotificationType of module AlarmIRPConstDefs in case the alarm has changed but has not yet been cleared. NOTIFY_FM_CLEARED_ALARM of interface NotificationType of module AlarmIRPConstDefs in case the alarm has been cleared but not yet acknowledged.
alamType	See Table A.2.3.1	M	See Table A.2.3.1
There is no corresponding SS attribute.	variable Header		
objectClass, objectInstance	See Table A.2.3.1	M	See Table A.2.3.1
notificationId	See Table A.2.3.1	M	See Table A.2.3.1
eventTime	See Table A.2.3.1	O	See Table A.2.3.1 The parameter carries the <ul style="list-style-type: none"> alamRaisedTime in case notificationType carries NOTIFY_FM_NEW_ALARM alamChangedTime in case notificationType carries NOTIFY_FM_CHANGED_ALARM alamClearedTime in case notificationType carries NOTIFY_FM_CLEARED_ALARM
systemDN	See Table A.2.3.1	M	See Table A.2.3.1
alamId	See Table A.2.3.1	M	See Table A.2.3.1
alamRaisedTime	One NV pair of filterable_body_fields	M	Name of NV pair is the ALARM_RAISED_TIME of interface AttributeNameValue of module AlarmIRPConstDefs. Value of NV pair is a IRPTime of module ManagedGenericIRPConstDefs.
alamChangedTime	One NV pair of filterable_body_fields	O	Name of NV pair is the ALARM_CHANGED_TIME of interface AttributeNameValue of module AlarmIRPConstDefs. Value of NV pair is a IRPTime of module ManagedGenericIRPConstDefs.
alamClearedTime	One NV pair of filterable_body_fields	M	present if related alarm was cleared; not present if related alarm was not cleared Name of NV pair is the ALARM_CLEARED_TIME of interface AttributeNameValue of module AlarmIRPConstDefs. Value of NV pair is a IRPTime of module ManagedGenericIRPConstDefs.
probableCause	See Table A.2.3.1	M	See Table A.2.3.1
perceivedSeverity	See Table A.2.3.1	M	See Table A.2.3.1
rootCauseIndicator	See Table A.2.3.1	O	See Table A.2.3.1
specificProblem	See Table A.2.3.1	O	See Table A.2.3.1
additionalText	See Table A.2.3.1	O	See Table A.2.3.1
additionalInformation	See Table A.2.3.1	O	See Table A.2.3.1
ackTime	See Table A.2.3.3	M	present if related alarm was acknowledged or unacknowledged; not present if related alarm was not acknowledged or unacknowledged

IS Parameters	OMG CORBA Structured Event attribute	Qualifier	Comment
			See Table A.2.3.3
ackUserId	See Table A.2.3.3	M	present if related alarm was acknowledged or unacknowledged; not present if related alarm was not acknowledged or unacknowledged See Table A.2.3.3
ackSystemId	See Table A.2.3.3	O	optionally present if related alarm was acknowledged or unacknowledged; not present if related alarm was not acknowledged or unacknowledged See Table A.2.3.3
ackState	See Table A.2.3.3	M	present if related alarm was acknowledged or unacknowledged; not present if related alarm was not acknowledged or unacknowledged See Table A.2.3.3
clearUserId	See Table A.2.3.4	O	optionally present if related alarm was cleared; not present if related alarm was not cleared See Table A.2.3.4
clearSystemId	See Table A.2.3.4	O	optionally present if related alarm was cleared; not present if related alarm was not cleared See Table A.2.3.4
correlatedNotifications	See Table A.2.3.1	O	See Table A.2.3.1
comments	See Table A.2.3.7	M	present if related alarm was commented; not present if related alarm was not commented See Table A.2.3.7
serviceUser	See Table A.2.3.2	M	See Table A.2.3.2
serviceProvider	See Table A.2.3.2	M	See Table A.2.3.2
securityAlarmDetector	See Table A.2.3.2	M	See Table A.2.3.2
There is no corresponding IS attribute.	remaining_body		

Table A.2.2.6: Mapping from IS getAlarmCount parameters to SS equivalents

IS Operation parameter	SS Method parameter	Qualifier
alarmAckState, filter	ManagedGenericRPConstDefs::StringOpt filter	O
criticalCount, majorCount, minorCount, warningCount, indeterminateCount, clearedCount	long critical_count, long major_count, long minor_count, long warning_count, long indeterminate_count, long cleared_count	M
status	Exceptions: GetAlarmCount, FilterComplexityLimit, ManagedGenericRPSystem::OperationNotSupported, ManagedGenericRPSystem::ParameterNotSupported, ManagedGenericRPSystem::InvalidParameter	M

Table A.2.2.7: Mapping from IS getIRPVersion parameters to SS equivalents

IS Operation parameter	SS Method parameter	Qualifier
versionNumberSet	Return value of type ManagedGenericRPConstDefs::VersionNumberSet	M
status	Exceptions: GetAlarmIRPVersions	M

Table A.2.2.8: Mapping from IS setComment parameters to SS equivalents

IS Operation parameter	SS Method parameter	Qualifier
alarmInformationReferenceList	AlarmIRPCConstDefs::AlarmInformationIdSeq alarm_information_id_list	M
commentUserId	string comment_user_id	M
commentSystemId	ManagedGenericRPCConstDefs::StringOpt comment_system_id	O
commentText	string comment_text	M
badAlarmInformationReferenceList	AlarmIRPCConstDefs::BadAlarmInformationIdSeq bad_alarm_information_id_list	M
status	ManagedGenericRPCConstDefs::Signal Exceptions: CommentAlarms, ManagedGenericRPSSystem::OperationNotSupported, ManagedGenericRPSSystem::ParameterNotSupported, ManagedGenericRPSSystem::InvalidParameter	M

Table A.2.2.9: Mapping from IS getOperationProfile parameters to SS equivalents

IS Operation parameter	SS Method parameter	Qualifier
irpVersion	ManagedGenericRPCConstDefs::VersionNumber alarm_irp_version	M
operationNameProfile, operationParameterProfile	Return value of type ManagedGenericRPCConstDefs::MethodList	M
status	Exceptions: GetAlarmIRPOperationsProfile, ManagedGenericRPSSystem::OperationNotSupported, ManagedGenericRPSSystem::InvalidParameter	M

Table A.2.2.10: Mapping from IS getNotificationProfile parameters to SS equivalents

IS Operation parameter	SS Method parameter	Qualifier
irpVersion	ManagedGenericRPCConstDefs::VersionNumber alarm_irp_version	M
notificationNameProfile, notificationParameterProfile	Return value of type ManagedGenericRPCConstDefs::MethodList	M
status	Exceptions: GetAlarmIRPNotificationProfile, ManagedGenericRPSSystem::OperationNotSupported, ManagedGenericRPSSystem::InvalidParameter	M

Table A.2.2.11: Mapping from IS clearAlarms parameters to SS equivalents

IS Operation parameter	SS Method parameter	Qualifier
alarmInformationReferenceList	AlarmIRPCConstDefs::AlarmInformationIdSeq alarm_information_id_list	M
clearUserId	string clear_user_id	M
clearSystemId	string clear_system_id	O
badAlarmInformationReferenceList	AlarmIRPCConstDefs::BadAlarmInformationIdSeq bad_alarm_information_id_list	M
status	ManagedGenericRPCConstDefs::Signal Exceptions: ClearAlarms, ManagedGenericRPSSystem::OperationNotSupported, ManagedGenericRPSSystem::ParameterNotSupported, ManagedGenericRPSSystem::InvalidParameter	M

A.2.3 Notification parameter mapping

Reference 3G TS 32.111-2 [4] defines semantics of parameters carried in notifications. The following tables indicate the mapping of these parameters to their OMG CORBA Structured Event (defined in OMG Notification Service [14]) equivalents. The composition of OMG Structured Event, as defined in the OMG Notification Service [14], is:

```

Header
  Fixed Header
    domain_name
    type_name
    event_name
  Variable Header
Body
  filterable_body_fields
  remaining_body

```

The following tables list all OMG Structured Event attributes in the second column. The first column identifies the Alarm IRP: IS [4] defined notification parameters.

Table A.2.3.1: Mapping for notifyNewAlarm (to carry non-security-related alarms)

IS Parameters	OMG CORBA Structured Event attribute	Qualifier	Comment
There is no corresponding SS attribute.	domain_name		It carries the IRP document version number string. See sub-clause 3.1. It indicates the syntax and semantics of the Structured Event as defined by this specification.
notificationType	type_name	M	This is the NOTIFY_FM_NEW_ALARM of interface NotificationType of module AlarmIRPConstDefs.
alamType	event_name	M	It identifies one of the following: communications alarm, processing error alarm, environmental alarm, quality of service alarm and equipment alarm. It is a string defined by interface AlarmType of module AlarmIRPConstDefs.
There is no corresponding SS attribute.	variable Header		
objectClass, objectInstance	One NV pair of filterable_body_fields	M	NV stands for name-value pair. Order arrangement of NV pairs is not significant. The name of NV-pair is always encoded in string. Name of NV pair is the MANAGED_OBJECT_INSTANCE of interface AttributeNameValue of module NotificationIRPConstDefs. Value of NV pair is a string.
notificationId	One NV pair of remaining_body	M	Name of NV pair is the NOTIFICATION_ID of interface AttributeNameValue of module NotificationIRPConstDefs. Value of NV pair is a long.
eventTime	One NV pair of filterable_body_fields	M	Name of NV pair is the EVENT_TIME of interface AttributeNameValue of module NotificationIRPConstDefs. Value of NV pair is a IRPTime of module ManagedGenericIRPConstDefs.
systemDN	One NV pair of filterable_body_fields	M	Name of NV pair is the SYSTEM_DN of interface AttributeNameValue of module NotificationIRPConstDefs. Value of NV pair is a string.

IS Parameters	OMG CORBA Structured Event attribute	Qualifier	Comment
probableCause	One NV pair of filterable_body_fields	M	Name of NV pair is the PROBABLE_CAUSE of interface AttributeNameValue of module AlarmIRPCConstDefs. Value of NV pair is a short defined by interface ProbableCause of module AlarmIRPCConstDefs.
perceivedSeverity	One NV pair of filterable_body_fields	M	Name of NV pair is the PERCEIVED_SEVERITY of interface AttributeNameValue of module AlarmIRPCConstDefs. Value of NV pair is a short defined by interface PerceivedSeverity of module AlarmIRPCConstDefs.
rootCauseIndicator	One NV pair of filterable_body_fields	O	Name of NV pair is the ROOT_CAUSE_INDICATOR of interface AttributeNameValue of module AlarmIRPCConstDefs. Value of NV pair is a boolean defined by interface RootCauseIndicator of module AlarmIRPCConstDefs.
specificProblem	One NV pair of remaining_body	O	Name of NV pair is the SPECIFIC_PROBLEM of interface AttributeNameValue of module AlarmIRPCConstDefs. Value of NV pair is a string.
correlatedNotifications	One NV pair of remaining_body	O	Name of NV pair is the CORRELATED_NOTIFICATIONS of interface AttributeNameValue. Value of NV pair is a CorrelatedNotificationSet of module AlarmIRPCConstDefs.
backedUpStatus	One NV pair of remaining_body	O	Name of NV pair is the BACKED_UP_STATUS of interface AttributeNameValue of module AlarmIRPCConstDefs. Value of NV pair is a boolean BackedUpStatus of module AlarmIRPCConstDefs.
backUpObject	One NV pair of remaining_body	O	Name of NV pair is the BACK_UP_OBJECT of interface AttributeNameValue of module AlarmIRPCConstDefs. Value of NV pair is a string carrying of DN of the back-up object. See 3G TS 32.300 [6] for the DN string representation.
trendIndication	One NV pair of remaining_body	O	Name of NV pair is the TREND_INDICATION of interface AttributeNameValue of module AlarmIRPCConstDefs. Value of NV pair is an enum TrendIndication of module AlarmIRPCConstDefs.
thresholdInfo	One NV pair of remaining_body	O	Name of NV pair is the THRESHOLD_INFO of interface ParameterNameValue of module AlarmIRPCConstDefs. Value of NV pair is a ThresholdInfo of module AlarmIRPCConstDefs.
stateChangeDefinition	One NV pair of remaining_body	O	Name of NV pair is the STATE_CHANGE_DEFINITION of interface AttributeNameValue of module AlarmIRPCConstDefs. Value of NV pair is an AttributeChangeSet of module AlarmIRPCConstDefs.
monitoredAttributes	One NV pair of remaining_body	O	Name of NV pair is the MONITORED_ATTRIBUTES of interface AttributeNameValue of module AlarmIRPCConstDefs. Value of NV pair is an AttributeSet of module AlarmIRPCConstDefs.
proposedRepairActions	One NV pair of remaining_body	O	Name of NV pair is the PROPOSED_REPAIR_ACTIONS of interface AttributeNameValue of module AlarmIRPCConstDefs. Value of NV pair is a string.
additionalText	One NV pair of remaining_body	O	Name of NV pair is the ADDITIONAL_TEXT of interface AttributeNameValue of module AlarmIRPCConstDefs. Value of NV pair is a string.

IS Parameters	OMG CORBA Structured Event attribute	Qualifier	Comment
additionalInformation	One or more NV pairs of remaining_body	O	3GPP defines two Additional Information (AI) NV pairs for carrying vendor-specific (VS) perceived severity and alarm type. The names of these two NV pairs are: <ul style="list-style-type: none"> AI_VS_PERCEIVED_SEVERITY AI_VS_ALARM_TYPE of interface AdditionalInformation of module AlarmIRPConstDefs. The values of these two NV pairs are vendor defined. Other AI NV pairs are permitted to capture specific information. To be easily identified as vendor specific, the name value of these NV pairs should take the form of "ai_vs_<non-empty string>". The value of this NV pair is vendor defined.
alarmId	One NV pair of remaining_body	M	Name of NV pair is the ALARM_ID of interface AttributeNameValue of module AlarmIRPConstDefs. Value of NV pair is a string. If the string is a zero-length string or if this NV pair is absent, the default semantics is that alarmId is a concatenation of managedObjectInstance, eventType, probableCause and specificProblem, if present, of this Structured Event. Since probableCause is encoded as a short, it shall be converted into string before concatenation. The resultant string shall not contain spaces.

Table A.2.3.2: Mapping for notifyNewAlarm (to carry security alarm)

IS Parameters	OMG CORBA Structured Event attribute	Qualifier	Comment
There is no corresponding SS attribute.	domain_name		It carries the IRP document version number string. See sub-clause 3.1. It indicates the syntax and semantics of the Structured Event as defined by this specification.
notificationType	type_name	M	This is the NOTIFY_FM_NEW_ALARM of interface NotificationType of module AlarmIRPConstDefs.
alarmType	event_name	M	It identifies one of the following: Integrity violation, operational violation, physical violation, security violation and time domain violation. It is a string defined by interface AlarmType of module AlarmIRPConstDefs.
There is no corresponding SS attribute.	variable Header		
objectClass, objectInstance	One NV pair of filterable_body_fields	M	NV stands for name-value pair. Order arrangement of NV pairs is not significant. The name of NV-pair is always encoded in string. Name of NV pair is the MANAGED_OBJECT_INSTANCE of interface AttributeNameValue of module NotificationIRPConstDefs. Value of NV pair is a string.
notificationId	One NV pair of remaining_body	M	Name of NV pair is the NOTIFICATION_ID of interface AttributeNameValue of module NotificationIRPConstDefs. Value of NV pair is a long.

IS Parameters	OMG CORBA Structured Event attribute	Qualifier	Comment
eventTime	One NV pair of filterable_body_fields	M	Name of NV pair is the EVENT_TIME of interface AttributeNameValue of module NotificationIRPCConstDefs. Value of NV pair is a IRPTime of module ManagedGenericIRPCConstDefs.
systemDN	One NV pair of filterable_body_fields	M	Name of NV pair is the SYSTEM_DN of interface AttributeNameValue of module NotificationIRPCConstDefs. Value of NV pair is a string.
probableCause	One NV pair of filterable_body_fields	M	Name of NV pair is the PROBABLE_CAUSE of interface AttributeNameValue of module AlarmIRPCConstDefs. Value of NV pair is a short defined by interface ProbableCause of module AlarmIRPCConstDefs.
perceivedSeverity	One NV pair of filterable_body_fields	M	Name of NV pair is the PERCEIVED_SEVERITY of interface AttributeNameValue of module AlarmIRPCConstDefs. Value of NV pair is a short defined by interface PerceivedSeverity of module AlarmIRPCConstDefs.
rootCauseIndicator	One NV pair of filterable_body_fields	O	Name of NV pair is the ROOT_CAUSE_INDICATOR of interface AttributeNameValue. Value of NV pair is a boolean defined by interface RootCauseIndicator of module AlarmIRPCConstDefs.
correlatedNotifications	One NV pair of remaining_body	O	Name of NV pair is the CORRELATED_NOTIFICATIONS of interface AttributeNameValue. Value of NV pair is a CorrelatedNotificationSet of module AlarmIRPCConstDefs.
additionalText	One NV pair of remaining_body	O	Name of NV pair is the ADDITIONAL_TEXT of interface AttributeNameValue of module AlarmIRPCConstDefs. Value of NV pair is a string.
additionalInformation	One or more NV pairs of remaining_body	O	3GPP defines two Additional Information (AI) NV pairs for carrying vendor-specific (VS) perceived severity and alarm type. The names of these two NV pairs are: <ul style="list-style-type: none"> • AI_VS_PERCEIVED_SEVERITY • AI_VS_ALARM_TYPE of interface AdditionalInformation of module AlarmIRPCConstDefs. The values of these two NV pairs are vendor defined. Other AI NV pairs are permitted to capture specific information. To be easily identified as vendor specific, the name value of these NV pairs should take the form of "ai_vs_<non-empty string>". The value of this NV pair is vendor defined.
alarmId	One NV pair of remaining_body	M	Name of NV pair is the ALARM_ID of interface AttributeNameValue of module AlarmIRPCConstDefs. Value of NV pair is a string. If the string is a zero-length string or if this NV pair is absent, the default semantics is that alarmId is a concatenation of managedObjectInstance, eventType, probableCause and specificProblem, if present, of this Structured Event. Since probableCause is encoded as a short, it shall be converted into string before concatenation. The resultant string shall not contain spaces.

IS Parameters	OMG CORBA Structured Event attribute	Qualifier	Comment
serviceUser	One NV pair of remaining_body	M	Name of NV pair is the SERVICE_USER of interface AttributeNameValue of module AlarmIRPCConstDefs. Value of NV pair is a string.
serviceProvider	One NV pair of remaining_body	M	Name of NV pair is the SERVICE_PROVIDER of interface AttributeNameValue of module AlarmIRPCConstDefs. Value of NV pair is a string.
securityAlarmDetector	One NV pair of remaining_body	M	Name of NV pair is the SECURITY_ALARM_DETECTOR of interface AttributeNameValue of module AlarmIRPCConstDefs. Value of NV pair is a string.

Table A.2.3.3: Mapping for notifyAckStateChanged

IS Parameters	OMG CORBA Structured Event attribute	Qualifier	Comment
There is no corresponding IS attribute.	domain_name		See that of notifyNewAlarm.
notificationType	type_name	M	This is the NOTIFY_FM_ACK_STATE_CHANGED of interface NotificationType of module AlarmIRPCConstDefs.
alarmType	event_name	M	See that of notifyNewAlarm.
There is no corresponding IS attribute.	variable Header		
objectClass, objectInstance	One NV pair of filterable_body_fields	M	See that of notifyNewAlarm.
notificationId	One NV pair of remaining_body	M	See that of notifyNewAlarm.
eventTime	One NV pair of filterable_body_fields	M	See that of notifyNewAlarm.
systemDN	One NV pair of filterable_body_fields	M	See that of notifyNewAlarm.
probableCause	One NV pair of filterable_body_fields	M	See that of notifyNewAlarm.
perceivedSeverity	One NV pair of filterable_body_fields	M	See that of notifyNewAlarm.
alarmId	One NV pair of remaining_body	M	See that of notifyNewAlarm.
ackUserId	One NV pair of remaining_body	M	Name of NV pair is the ACK_USER_ID of interface AttributeNameValue of module AlarmIRPCConstDefs. Value of NV pair is a string.
ackSystemId	One NV pair of remaining_body	O	Name of NV pair is the ACK_SYSTEM_ID of interface AttributeNameValue of module AlarmIRPCConstDefs. Value of NV pair is a string.
ackState	One NV pair of remaining_body	M	Name of NV pair is the ACK_STATE of interface AttributeNameValue of module AlarmIRPCConstDefs. Value of NV pair is a short defined by interface AckState of module AlarmIRPCConstDefs.

Table A.2.3.4: Mapping for notifyClearedAlarm

IS Parameters	OMG CORBA Structured Event attribute	Qualifier	Comment
There is no corresponding IS attribute.	domain_name		See that of notifyNewAlarm.
notificationType	type_name	M	This is the NOTIFY_FM_CLEARED_ALARM of interface NotificationType of module AlarmIRPConstDefs.
alamType	event_name	M	See that of notifyNewAlarm.
There is no corresponding IS attribute.	variable Header		
objectClass, objectInstance	One NV pair of filterable_body_fields	M	See that of notifyNewAlarm.
notificationId	One NV pair of remaining_body	M	See that of notifyNewAlarm.
eventTime	One NV pair of filterable_body_fields	M	See that of notifyNewAlarm.
systemDN	One NV pair of filterable_body_fields	M	See that of notifyNewAlarm.
probableCause	One NV pair of filterable_body_fields	M	See that of notifyNewAlarm.
perceivedSeverity	One NV pair of filterable_body_fields	M	See that of notifyNewAlarm.
correlatedNotifications	--	--	See Note.
alamId	One NV pair of remaining_body	M	See that of notifyNewAlarm.
clearUserId	One NV pair of remaining_body	O	Name of NV pair is the CLEAR_USER_ID of interface AttributeNameValue of module AlarmIRPConstDefs. Value of NV pair is a string.
clearSystemId	One NV pair of remaining_body	O	Name of NV pair is the CLEAR_SYSTEM_ID of interface AttributeNameValue of module AlarmIRPConstDefs. Value of NV pair is a string.
NOTE:	In the CORBA Solution Set the correlatedNotifications is not used. In the CORBA Solution Set, one notifyClearedAlarm notification can only clear a single alamInformation.		

Table A.2.3.5: Mapping for notifyAlarmListRebuilt

IS Parameters	OMG CORBA Structured Event attribute	Qualifier	Comment
There is no corresponding IS attribute.	domain_name		See that of notifyNewAlarm.
notificationType	type_name	M	This is the NOTIFY_FM_ALARM_LIST_REBUILT of interface NotificationType of module AlarmIRPCConstDefs.
There is no corresponding IS attribute.	event_name	M	Carry an empty string.
There is no corresponding IS attribute.	variable Header		
objectClass, objectInstance	One NV pair of filterable_body_fields	M	See that of notifyNewAlarm.
notificationId	One NV pair of remaining_body	M	See that of notifyNewAlarm.
eventTime	One NV pair of filterable_body_fields	M	See that of notifyNewAlarm.
systemDN	One NV pair of filterable_body_fields	O	See that of notifyNewAlarm.
reason	One NV pair of remaining_body	M	Name of NV pair is the REASON of interface AttributeNameValue of module AlarmIRPCConstDefs. Value of NV pair is a string.
alarmListAlignmentRequirement	One NV pair of remaining_body	O	Name of NV pair is the ALARM_LIST_ALIGNMENT_REQUIREMENT of interface AttributeNameValue of module AlarmIRPCConstDefs. Value of NV pair is an enum AlarmListAlignmentRequirement of module AlarmIRPCConstDefs.

Table A.2.3.6: Mapping for notifyChangedAlarm

IS Parameters	OMG CORBA Structured Event attribute	Qualifier	Comment
There is no corresponding IS attribute.	domain_name		See that of notifyNewAlarm.
notificationType	type_name	M	This is the NOTIFY_FM_CHANGED_ALARM of interface NotificationType of module AlarmIRPCConstDefs.
alarmType	event_name	M	See that of notifyNewAlarm.
There is no corresponding IS attribute.	variable Header		
objectClass, objectInstance	One NV pair of filterable_body_fields	M	See that of notifyNewAlarm.
notificationId	One NV pair of remaining_body	M	See that of notifyNewAlarm.
eventTime	One NV pair of filterable_body_fields	M	See that of notifyNewAlarm.
systemDN	One NV pair of filterable_body_fields	M	See that of notifyNewAlarm.
probableCause	One NV pair of filterable_body_fields	M	See that of notifyNewAlarm.
perceivedSeverity	One NV pair of filterable_body_fields	M	See that of notifyNewAlarm.
alarmId	One NV pair of remaining_body	M	See that of notifyNewAlarm.

Table A.2.3.7: Mapping for `notifyComments`

IS Parameters	OMG CORBA Structured Event attribute	Qualifier	Comment
There is no corresponding IS attribute.	domain_name		See that of <code>notifyNewAlarm</code> .
notificationType	type_name	M	This is the <code>NOTIFY_FM_COMMENT_ADDED</code> of interface <code>NotificationType</code> of module <code>AlarmIRPCConstDefs</code> .
alarmType	event_name	M	See that of <code>notifyNewAlarm</code> .
There is no corresponding IS attribute.	variable Header		
objectClass, objectInstance	One NV pair of filterable_body_fields	M	See that of <code>notifyNewAlarm</code> .
notificationId	One NV pair of remaining_body	M	See that of <code>notifyNewAlarm</code> .
eventTime	One NV pair of filterable_body_fields	M	See that of <code>notifyNewAlarm</code> .
systemDN	One NV pair of filterable_body_fields	M	See that of <code>notifyNewAlarm</code> .
probableCause	One NV pair of filterable_body_fields	M	See that of <code>notifyNewAlarm</code> .
perceivedSeverity	One NV pair of filterable_body_fields	M	See that of <code>notifyNewAlarm</code> .
alarmId	One NV pair of remaining_body	M	See that of <code>notifyNewAlarm</code> .
comments	One NV pair of remaining_body	M	Name of NV pair is the <code>COMMENTS</code> of interface <code>AttributeNameValue</code> of module <code>AlarmIRPCConstDefs</code> . Value of NV pair is a <code>CommentSet</code> of module <code>AlarmIRPCConstDefs</code> .

Table A.2.3.8: Mapping for `notifyPotentialFaultyAlarmList`

IS Parameters	OMG CORBA Structured Event attribute	Qualifier	Comment
There is no corresponding IS attribute.	domain_name		See that of <code>notifyNewAlarm</code> .
notificationType	type_name	M	This is the <code>NOTIFY_FM_POTENTIAL_FAULTY_ALARM_LIST</code> of interface <code>NotificationType</code> of module <code>AlarmIRPCConstDefs</code> .
There is no corresponding IS attribute.	event_name	M	It contains a NULL string.
There is no corresponding IS attribute.	variable Header		
objectClass, objectInstance	One NV pair of filterable_body_fields	M	See <code>notifyNewAlarm</code> . See sub-clause "Definition" of this notification in [4] for the description of the usage of this field to indicate if part or all <code>AlarmList</code> is potentially faulty.
notificationId	One NV pair of remaining_body	M	
eventTime	One NV pair of filterable_body_fields	M	See <code>notifyNewAlarm</code> .
systemDN	One NV pair of filterable_body_fields	M	See <code>notifyNewAlarm</code> .
reason	One NV pair of remaining_body	M	Name of NV pair is the <code>REASON</code> of interface <code>AttributeNameValue</code> of module <code>AlarmIRPCConstDefs</code> . Value of NV pair is a string.

Table A.2.3.9: Mapping for notifyCorrelatedNotificationChanged

IS Parameters	OMG CORBA Structured Event attribute	Qualifier	Comment
There is no corresponding IS attribute.	domain_name		See that of notifyNewAlarm.
notificationType	type_name	M	This is the NOTIFY_FM_CORRELATED_NOTIFICATION_CHANGED of interface NotificationType of module AlarmIRPConstDefs.
alarmType	event_name	M	See that of notifyNewAlarm.
There is no corresponding IS attribute.	variable Header		
objectClass, objectInstance	One NV pair of filterable_body_fields	M	See that of notifyNewAlarm.
notificationId	One NV pair of remaining_body	M	See that of notifyNewAlarm.
eventTime	One NV pair of filterable_body_fields	M	See that of notifyNewAlarm.
systemDN	One NV pair of filterable_body_fields	M	See that of notifyNewAlarm.
correlatedNotifications	One NV pair of remaining_body	O	Name of NV pair is the CORRELATED_NOTIFICATIONS of interface AttributeNameValue. Value of NV pair is a CorrelatedNotificationSet of module AlarmIRPConstDefs.
alarmId	One NV pair of remaining_body	M	See that of notifyNewAlarm.
rootCauseIndicator	One NV pair of remaining_body	O	See that of notifyNewAlarm.

A.3 Solution Set definitions

A.3.1 IDL definition structure

Clause A.3.2 defines the constants and types used by the Alarm IRP.

Clause A.3.3 defines the operations which are performed by the Alarm IRP agent.

Clause A.3.4 defines the notifications which are emitted by the Alarm IRP agent.

A.3.2 IDL specification "AlarmIRPConstDefs.idl"

```
//File: AlarmIRPConstDefs.idl
#ifndef _ALARM_IRP_CONST_DEFS_IDL_
#define _ALARM_IRP_CONST_DEFS_IDL_
#include <CosNotification.idl>
#include <ManagedGenericIRPConstDefs.idl>
// This statement must appear after all include statements
#pragma prefix "3gppsa5.org"
/* ## Module: AlarmIRPConstDefs
This module contains commonly used definitions for Alarm IRP
=====
*/
module AlarmIRPConstDefs
{
    /*
    The format of Distinguished Name (DN) is specified in 3GPP TS 32.300
    "Name Conventions for Managed Objects".
    */
    typedef string DN;
    /* DNOpt is an optional type.
```

```

If the discriminator is true the value is present.
Otherwise the value is null.
*/
union DNOpt switch (boolean)
{
    case TRUE: DN value;
};
/*
This block identifies the alarm types specified for this IRP version.
These types carry the same semantics as the TMN ITU-T defined event
types of the same name.
Their encodings for this version of Alarm IRP are defined here. Other IRP
documents, or other versions of Alarm IRP, shall identify their own
alarm types for their use. They shall define their encodings
as well. Values defined here are unique among themselves.
*/
interface AlarmType
{
    const string COMMUNICATIONS_ALARM = "x1";
    const string PROCESSING_ERROR_ALARM = "x2";
    const string ENVIRONMENTAL_ALARM = "x3";
    const string QUALITY_OF_SERVICE_ALARM = "x4";
    const string EQUIPMENT_ALARM = "x5";
    const string INTEGRITY_VIOLATION = "x6";
    const string OPERATIONAL_VIOLATION = "x7";
    const string PHYSICAL_VIOLATION = "x8";
    const string SECURITY_SERVICE_OR_MECHANISM_VIOLATION = "x9";
    const string TIME_DOMAIN_VIOLATION = "x10";
};
/*
This block identifies the notification types defined by this
Alarm IRP version.
*/
interface NotificationType
{
    const string NOTIFY_FM_NEW_ALARM = "x1";
    const string NOTIFY_FM_CHANGED_ALARM = "x2";
    const string NOTIFY_FM_ACK_STATE_CHANGED = "x3";
    const string NOTIFY_FM_COMMENT_ADDED = "x4";
    const string NOTIFY_FM_CLEARED_ALARM = "x5";
    const string NOTIFY_FM_ALARM_LIST_REBUILT = "x6";
    const string NOTIFY_FM_POTENTIAL_FAULTY_ALARM_LIST = "x7";
    const string NOTIFY_FM_CORRELATED_NOTIFICATION_CHANGED = "x8";
};
/*
This block identifies the levels of severity.
*/
interface PerceivedSeverity
{
    const short INDETERMINATE = 1;
    const short CRITICAL = 2;
    const short MAJOR = 3;
    const short MINOR = 4;
    const short WARNING = 5;
    const short CLEARED = 6;
};
/*
This block identifies the probable cause of a reported alarm.
*/
interface ProbableCause
{
    /*
    Probable causes originating from M.3100.
    Values below correspond to M.3100 values.
    */
    const short INDETERMINATE = 0;
    const short ALARM_INDICATION_SIGNAL = 1;
    const short CALL_SETUP_FAILURE = 2;
    const short DEGRADED_SIGNAL = 3;
    const short FAR_END_RECEIVER_FAILURE = 4;
    const short FRAMING_ERROR = 5;
    const short LOSS_OF_FRAME = 6;
    const short LOSS_OF_POINTER = 7;
    const short LOSS_OF_SIGNAL = 8;
    const short PAYLOAD_TYPE_MISMATCH = 9;
    // Values 10 correspond to a duplicated probable cause
    const short REMOTE_ALARM_INTERFACE = 11;
    const short EXCESSIVE_BIT_ERROR_RATE = 12;
};

```

```
const short PATH_TRACE_MISMATCH = 13;
const short UNAVAILABLE = 14;
const short SIGNAL_LABEL_MISMATCH = 15;
const short LOSS_OF_MULTIFRAME = 16;
const short COMMUNICATIONS_RECEIVE_FAILURE = 17;
const short COMMUNICATIONS_TRANSMIT_FAILURE = 18;
const short MODULATION_FAILURE = 19;
const short DEMODULATION_FAILURE = 20;
// Values 21-26 correspond to duplicated probable causes
// Values 27-50 are reserved for M.3100 potential future extensions
const short BACKPLANE_FAILURE = 51;
const short DATA_SET_PROBLEM = 52;
const short EQUIPMENT_IDENTIFIER_DUPLICATION = 53;
const short EXTERNAL_IF_DEVICE_PROBLEM = 54;
const short LINE_CARD_PROBLEM = 55;
const short MULTIPLEXER_PROBLEM = 56;
const short NE_IDENTIFIER_DUPLICATION = 57;
const short POWER_PROBLEM = 58;
const short PROCESSOR_PROBLEM = 59;
const short PROTECTION_PATH_FAILURE = 60;
const short RECEIVER_FAILURE = 61;
const short REPLACEABLE_UNIT_MISSING = 62;
const short REPLACEABLE_UNIT_TYPE_MISMATCH = 63;
const short SYNCHRONIZATION_SOURCE_MISMATCH = 64;
const short TERMINAL_PROBLEM = 65;
const short TIMING_PROBLEM = 66;
const short TRANSMITTER_FAILURE = 67;
const short TRUNK_CARD_PROBLEM = 68;
const short REPLACEABLE_UNIT_PROBLEM = 69;
const short REAL_TIME_CLOCK_FAILURE = 70;
// Values 71-80 correspond to duplicated probable causes
const short PROTECTION_MECHANISM_FAILURE = 81;
const short PROTECTING_RESOURCE_FAILURE = 82;
// Values 83-100 are reserved for M.3100 potential future extensions
const short AIR_COMPRESSOR_FAILURE = 101;
const short AIR_CONDITIONING_FAILURE = 102;
const short AIR_DRYER_FAILURE = 103;
const short BATTERY_DISCHARGING = 104;
const short BATTERY_FAILURE = 105;
const short COMMERCIAL_POWER_FAILURE = 106;
const short COOLING_FAN_FAILURE = 107;
const short ENGINE_FAILURE = 108;
const short FIRE_DETECTOR_FAILURE = 109;
const short FUSE_FAILURE = 110;
const short GENERATOR_FAILURE = 111;
const short LOW_BATTERY_THRESHOLD = 112;
const short PUMP_FAILURE = 113;
const short RECTIFIER_FAILURE = 114;
const short RECTIFIER_HIGH_VOLTAGE = 115;
const short RECTIFIER_LOW_VOLTAGE = 116;
const short VENTILATION_SYSTEM_FAILURE = 117;
const short ENCLOSURE_DOOR_OPEN = 118;
const short EXPLOSIVE_GAS = 119;
const short FIRE = 120;
const short FLOOD = 121;
const short HIGH_HUMIDITY = 122;
const short HIGH_TEMPERATURE = 123;
const short HIGH_WIND = 124;
const short ICE_BUILD_UP = 125;
const short INTRUSION_DETECTION = 126;
const short LOW_FUEL = 127;
const short LOW_HUMIDITY = 128;
const short LOW_CABLE_PRESSURE = 129;
const short LOW_TEMPERATURE = 130;
const short LOW_WATER = 131;
const short SMOKE = 132;
const short TOXIC_GAS = 133;
// Values 134-135 correspond to duplicated probable causes
const short EXTERNAL_POINT_FAILURE = 136;
// Values 137-150 are reserved for potential M.3100 future extensions
const short STORAGE_CAPACITY_PROBLEM = 151;
const short MEMORY_MISMATCH = 152;
const short CORRUPT_DATA = 153;
const short OUT_OF_CPU_CYCLES = 154;
const short SOFTWARE_ENVIRONMENT_PROBLEM = 155;
const short SOFTWARE_DOWNLOAD_FAILURE = 156;
const short LOSS_OF_REAL_TIME = 157;
const short REINITIALIZED = 158;
```

```
// Values 159-167 correspond to duplicated probable causes
// Values 168-200 are reserved for potential M.3100 future extensions
// Values 201-202 correspond to duplicated probable causes
const short EXCESSIVE_ERROR_RATE = 203;
// Values 204-207 correspond to duplicated probable causes
// Values 208-300 are reserved for potential M.3100 future extensions
/*
Probable causes originating from X.721.
Values below correspond to X.721 values with an offset of 300.
*/
const short ADAPTER_ERROR = 301;
const short APPLICATION_SUBSYSTEM_FAILURE = 302;
const short BANDWIDTH_REDUCED = 303;
// Value 304 corresponds to a duplicated probable cause
const short COMMUNICATIONS_PROTOCOL_ERROR = 305;
const short COMMUNICATIONS_SUBSYSTEM_FAILURE = 306;
const short CONFIGURATION_OR_CUSTOMIZATION_ERROR = 307;
const short CONGESTION = 308;
// Value 309 corresponds to a duplicated probable cause
const short CPU_CYCLES_LIMIT_EXCEEDED = 310;
const short DATA_SET_OR_MODEM_ERROR = 311;
// Value 312 corresponds to a duplicated probable cause
const short DTE_DCE_INTERFACE_ERROR = 313;
// Value 314 corresponds to a duplicated probable cause
const short EQUIPMENT_MALFUNCTION = 315;
const short EXCESSIVE_VIBRATION = 316;
const short FILE_ERROR = 317;
// Values 318-320 correspond to duplicated probable causes
const short HEATING_OR_VENTILATION_OR_COOLING_SYSTEM_PROBLEM = 321;
const short HUMIDITY_UNACCEPTABLE = 322;
const short INPUT_OUTPUT_DEVICE_ERROR = 323;
const short INPUT_DEVICE_ERROR = 324;
const short LAN_ERROR = 325;
const short LEAK_DETECTED = 326;
const short LOCAL_NODE_TRANSMISSION_ERROR = 327;
// Values 328-329 correspond to duplicated probable causes
const short MATERIAL_SUPPLY_EXHAUSTED = 330;
// Value 331 corresponds to a duplicated probable cause
const short OUT_OF_MEMORY = 332;
const short OUTPUT_DEVICE_ERROR = 333;
const short PERFORMANCE_DEGRADED = 334;
// Value 335 corresponds to a duplicated probable cause
const short PRESSURE_UNACCEPTABLE = 336;
// Values 337-338 correspond to duplicated probable causes
const short QUEUE_SIZE_EXCEEDED = 339;
const short RECEIVE_FAILURE = 340;
// Value 341 corresponds to a duplicated probable cause
const short REMOTE_NODE_TRANSMISSION_ERROR = 342;
const short RESOURCE_AT_OR_NEARING_CAPACITY = 343;
const short RESPONSE_TIME_EXCESSIVE = 344;
const short RETRANSMISSION_RATE_EXCESSIVE = 345;
const short SOFTWARE_ERROR = 346;
const short SOFTWARE_PROGRAM_ABNORMALLY_TERMINATED = 347;
const short SOFTWARE_PROGRAM_ERROR = 348;
// Value 349 corresponds to a duplicated probable cause
const short TEMPERATURE_UNACCEPTABLE = 350;
const short THRESHOLD_CROSSED = 351;
// Value 352 corresponds to a duplicated probable cause
const short TOXIC_LEAK_DETECTED = 353;
const short TRANSMIT_FAILURE = 354;
// Value 355 corresponds to a duplicated probable cause
const short UNDERLYING_RESOURCE_UNAVAILABLE = 356;
const short VERSION_MISMATCH = 357;
// Values 358-500 are reserved for potential X.721 future extensions
/*
Probable causes for 2G & 3G wireless systems.
*/
const short A_BIS_TO_BTS_INTERFACE_FAILURE = 501;
const short A_BIS_TO_TRX_INTERFACE_FAILURE = 502;
const short ANTENNA_PROBLEM = 503;
const short BATTERY_BREAKDOWN = 504;
const short BATTERY_CHARGING_FAULT = 505;
const short CLOCK_SYNCHRONIZATION_PROBLEM = 506;
const short COMBINER_PROBLEM = 507;
const short DISK_PROBLEM = 508;
// Value 509 corresponds to a duplicated probable cause
const short EXCESSIVE_RECEIVER_TEMPERATURE = 510;
const short EXCESSIVE_TRANSMITTER_OUTPUT_POWER = 511;
```

```
const short EXCESSIVE_TRANSMITTER_TEMPERATURE = 512;
const short FREQUENCY_HOPPING_DEGRADED = 513;
const short FREQUENCY_HOPPING_FAILURE = 514;
const short FREQUENCY_REDEFINITION_FAILED = 515;
const short LINE_INTERFACE_FAILURE = 516;
const short LINK_FAILURE = 517;
const short LOSS_OF_SYNCHRONIZATION = 518;
const short LOST_REDUNDANCY = 519;
const short MAINS_BREAKDOWN_WITH_BATTERY_BACKUP = 520;
const short MAINS_BREAKDOWN_WITHOUT_BATTERY_BACKUP = 521;
const short POWER_SUPPLY_FAILURE = 522;
const short RECEIVER_ANTENNA_FAULT = 523;
// Value 524 corresponds to a duplicated probable cause
const short RECEIVER_MULTICOUPLER_FAILURE = 525;
const short REDUCED_TRANSMITTER_OUTPUT_POWER = 526;
const short SIGNAL_QUALITY_EVALUATION_FAULT = 527;
const short TIMESLOT_HARDWARE_FAILURE = 528;
const short TRANSCEIVER_PROBLEM = 529;
const short TRANSCODER_PROBLEM = 530;
const short TRANSCODER_OR_RATE_ADAPTER_PROBLEM = 531;
const short TRANSMITTER_ANTENNA_FAILURE = 532;
const short TRANSMITTER_ANTENNA_NOT_ADJUSTED = 533;
// Value 534 corresponds to a duplicated probable cause
const short TRANSMITTER_LOW_VOLTAGE_OR_CURRENT = 535;
const short TRANSMITTER_OFF_FREQUENCY = 536;
const short DATABASE_INCONSISTENCY = 537;
const short FILE_SYSTEM_CALL_UNSUCCESSFUL = 538;
const short INPUT_PARAMETER_OUT_OF_RANGE = 539;
const short INVALID_PARAMETER = 540;
const short INVALID_POINTER = 541;
const short MESSAGE_NOT_EXPECTED = 542;
const short MESSAGE_NOT_INITIALIZED = 543;
const short MESSAGE_OUT_OF_SEQUENCE = 544;
const short SYSTEM_CALL_UNSUCCESSFUL = 545;
const short TIMEOUT_EXPIRED = 546;
const short VARIABLE_OUT_OF_RANGE = 547;
const short WATCH_DOG_TIMER_EXPIRED = 548;
const short COOLING_SYSTEM_FAILURE = 549;
const short EXTERNAL_EQUIPMENT_FAILURE = 550;
const short EXTERNAL_POWER_SUPPLY_FAILURE = 551;
const short EXTERNAL_TRANSMISSION_DEVICE_FAILURE = 552;
// Values 553-560 correspond to duplicated probable causes
const short REDUCED_ALARM_REPORTING = 561;
const short REDUCED_EVENT_REPORTING = 562;
const short REDUCED_LOGGING_CAPABILITY = 563;
const short SYSTEM_RESOURCES_OVERLOAD = 564;
const short BROADCAST_CHANNEL_FAILURE = 565;
const short CONNECTION_ESTABLISHMENT_ERROR = 566;
const short INVALID_MESSAGE_RECEIVED = 567;
const short INVALID_MSU_RECEIVED = 568;
const short LAPD_LINK_PROTOCOL_FAILURE = 569;
const short LOCAL_ALARM_INDICATION = 570;
const short REMOTE_ALARM_INDICATION = 571;
const short ROUTING_FAILURE = 572;
const short SS7_PROTOCOL_FAILURE = 573;
const short TRANSMISSION_ERROR = 574;
// Value 575 corresponds to a duplicated probable cause
// Values 576-700 are reserved for potential future extensions
// for 2G & 3G wireless systems
/*
Probable causes originating from M.3100 security alarm causes.
Values below correspond to M.3100 values with an offset of 700.
*/
const short AUTHENTICATION_FAILURE = 701;
const short BREACH_OF_CONFIDENTIALITY = 702;
const short CABLE_TAMPER = 703;
const short DELAYED_INFORMATION = 704;
const short DENIAL_OF_SERVICE = 705;
const short DUPLICATE_INFORMATION = 706;
const short INFORMATION_MISSING = 707;
const short INFORMATION_MODIFICATION_DETECTED = 708;
const short INFORMATION_OUT_OF_SEQUENCE = 709;
// Value 710 corresponds to a duplicated probable cause
const short KEY_EXPIRED = 711;
const short NON_REPUDIATION_FAILURE = 712;
const short OUT_OF_HOURS_ACTIVITY = 713;
const short OUT_OF_SERVICE = 714;
const short PROCEDURAL_ERROR = 715;
```

```

    const short UNAUTHORISED_ACCESS_ATTEMPT = 716;
    const short UNEXPECTED_INFORMATION = 717;
    const short UNSPECIFIED_REASON = 718;
    // Values 719-800 are reserved for potential M.3100 future extensions
};
/*
It indicates that this AlarmInformation is the root cause of the events captured by the
notifications whose identifiers are in the related CorrelatedNotification instances.
*/
typedef boolean RootCauseIndicator;

/*
This block identifies the acknowledgement state of a reported alarm.
*/
interface AckState
{
    const short ACKNOWLEDGED = 1;
    const short UNACKNOWLEDGED = 2;
};
/*
This block identifies attributes which are included as part of the Alarm IRP
These attribute values should not clash with those defined for the attributes
of notification header (see IDL of Notification IRP).
*/
interface AttributeNameValue
{
    const string ALARM_ID = "f";
    const string PROBABLE_CAUSE = "g";
    const string PERCEIVED_SEVERITY = "h";
    const string SPECIFIC_PROBLEM = "i";
    const string ADDITIONAL_TEXT = "j";
    const string ACK_TIME = "k";
    const string ACK_USER_ID = "l";
    const string ACK_SYSTEM_ID = "m";
    const string ACK_STATE = "n";
    const string COMMENTS = "o";
    const string BACKED_UP_STATUS = "p";
    const string BACK_UP_OBJECT = "q";
    const string THRESHOLD_INFO = "r";
    const string TREND_INDICATION = "s";
    const string STATE_CHANGE_DEFINITION = "t";
    const string MONITORED_ATTRIBUTES = "u";
    const string PROPOSED_REPAIR_ACTIONS = "v";
    const string CORRELATED_NOTIFICATIONS = "w";
    const string REASON = "x";
    const string CLEAR_USER_ID = "y";
    const string CLEAR_SYSTEM_ID = "z";
    const string ALARM_LIST_ALIGNMENT_REQUIREMENT = "ff";
    const string SERVICE_USER = "gg";
    const string SERVICE_PROVIDER = "hh";
    const string SECURITY_ALARM_DETECTOR = "ii";
    const string ALARM_RAISED_TIME = "kk";
    const string ALARM_CLEARED_TIME = "ll";
    const string ALARM_CHANGED_TIME = "mm";
    const string ROOT_CAUSE_INDICATOR = "nn";
};
/*
constants for use in populating the additional information
name field Names
*/
interface AdditionalInformation
{
    const string AI_VS_PERCEIVED_SEVERITY = "ai_ps";
    const string AI_VS_ALARM_TYPE = "ai_at";
};

/*
Defines the content of a Comment
*/
struct Comment
{
    ManagedGenericIRPConstDefs::IRPTime comment_time;
    string comment_text;
    string user_id;
    string system_id;
};
/*
Defines a set of comments which are placed in the COMMENTS attribute

```

```

of a structured event.
*/
typedef sequence <Comment> CommentSet;
/*
It indicates if an object has a back up.
True implies backed up. False implies not backed up.
*/
typedef boolean BackedUpStatus;
/*
It indicates if the threshold crossed was in the up or down direction.
*/
enum ThresholdIndication {UP, DOWN};
/*
It indicates if the AlarmList alignment is required.
*/
enum AlarmListAlignmentRequirement {REQUIRED, NOTREQUIRED};
/* FloatOpt is an optional type.
If the discriminator is true the value is present.
Otherwise the value is null.
*/
union FloatOpt switch (boolean)
{
    case TRUE: float value;
};
/* ThresholdLevelInd describes multi-level
threshold crossings.
Up is the only permitted choice for a counter.
If indication is "up", low value is optional.
@member indication: indicates up or down direction
of crossing.
@member low: the low observed value.
@member high: the high observed value.
*/
struct ThresholdLevelInd
{
    ThresholdIndication indication;
    FloatOpt low;
    float high;
};
/* ThresholdLevelIndOpt is an optional type.
If the discriminator is true the value is present.
Otherwise, the value is null.
*/
union ThresholdLevelIndOpt switch (boolean)
{
    case TRUE: ThresholdLevelInd value;
};
/* ThresholdInfo indicates some gauge or counter
attribute passed a set threshold.
@member attribute_id: identifies the attribute that
crossed the threshold.
@member observed_value: attributes that are of type
integer will be converted to floats.
@member threshold_level: This parameter is for
multi-level thresholds. Optional.
@member arm_time: May contain empty string.
*/
struct ThresholdInfo
{
    string attribute_id;
    float observed_value;
    ThresholdLevelIndOpt threshold_level;
    string arm_time;
};
/*
It indicates if some observed condition is getting better, worse,
or not changing.
*/
enum TrendIndication {LESS_SEVERE, NO_CHANGE, MORE_SEVERE};
/*
It is used to report a changed attribute value.
*/
struct AttributeValueChange
{
    string attribute_name;
    any old_value; // type depends on attribute
    any new_value; // type depends on attribute
};

```



```

typedef sequence <AttributeValueChange> AttributeChangeSet;
/*
It is used to report an attribute and its value.
*/
struct AttributeValue
{
    string attribute_name;
    any value; // type depends on the attribute
};
typedef sequence <AttributeValue> AttributeSet;
typedef sequence <long> NotifIdSet;
/*
This holds identifiers of notifications that are correlated.
*/
struct CorrelatedNotification
{
    DN source; // Contains DN of MO that emitted the set of notifications
              // DN string format in compliance with Name Convention for
              // Managed Object.
              // This may be a zero-length string. In this case, the MO
              // is identified by the value of the MOI attribute
              // of the Structured Event, i.e., the notification.
    NotifIdSet notif_id_set; // Set of related notification ids
};
/*
Correlated Notification sets are sets of Correlated Notification
structures.
*/
typedef sequence <CorrelatedNotification> CorrelatedNotificationSet;
/*
Define the structure of Alarm ID and Perceived Severity used within the
alarm acknowledgment operation. Note: perceived_severity is an optional
parameter. If this value is present, it must have one of the defined values
of Interface PerceivedSeverity.
*/
struct AlarmInformationIdAndSev
{
    string alarm_id;
    ManagedGenericIRPConstDefs::ShortOpt perceived_severity;
};
/*
Define set of the above structure of Alarm ID and Perceived Severity.
*/
typedef sequence <AlarmInformationIdAndSev> AlarmInformationIdAndSevSeq;
/*
It indicates the reason for an alarm acknowledgement to have failed:
- The specified Alarm Information is absent from the Alarm List
- The Perceived Severity to be acknowledged has changed and/or is different
  within the Alarm List
- The acknowledgement failed for some other reason
*/
enum AcknowledgeFailureCategories
{
    UNKNOWN_ALARM_ID,
    WRONG_PERCEIVED_SEVERITY,
    ACKNOWLEDGMENT_FAILED
};
/*
Define the structure returned when an operation fails for a set of alarm ids.
A reason is provided in order to indicate why the operation failed.
*/
struct BadAlarmInformationId
{
    string alarm_id;
    string reason;
};
/*
Define the structure returned when the acknowledge operation fails for a set
of alarm ids.
A failure category and a reason are provided in order to indicate why the
operation failed.
*/
struct BadAcknowledgeAlarmInfo
{
    string alarm_id;
    AcknowledgeFailureCategories failure_category;
    string reason;
};

```

```

typedef sequence <BadAlarmInformationId> BadAlarmInformationIdSeq;
typedef sequence <BadAcknowledgeAlarmInfo> BadAcknowledgeAlarmInfoSeq;
typedef sequence <string> AlarmInformationIdSeq;
typedef CosNotification::EventBatch AlarmInformationSeq;
/*
Define the cause values of notifyPotentialFaultyAlarmList and
notifyAlarmListRebuilt, which have been defined in 32111-2.
*/
const string AGENT_NE_COMMUNICATION_ERROR = "Agent-NE communication error";
const string AGENT_RESTARTS = "Agent restarts";
const string INDETERMINATE = "Indeterminate";
};
#endif // _ALARM_IRP_CONST_DEFS_IDL_

```

A.3.3 IDL specification “AlarmIRPSystem.idl”

```

//File: AlarmIRPSystem.idl
#ifndef _ALARM_IRP_SYSTEM_IDL_
#define _ALARM_IRP_SYSTEM_IDL_

#include <AlarmIRPConstDefs.idl>
#include <ManagedGenericIRPSystem.idl>

// This statement must appear after all include statements
#pragma prefix "3gppsa5.org"

/* ## Module: AlarmIRPSystem
This module contains the specification of all operations of Alarm IRP Agent.
=====
*/
module AlarmIRPSystem
{
    /*
    System fails to complete the operation. System can provide reason
    to qualify the exception. The semantics carried in reason
    is outside the scope of this IRP.
    */
    exception GetAlarmIRPVersions { string reason; };
    exception GetAlarmIRPOperationsProfile { string reason; };
    exception GetAlarmIRPNotificationProfile { string reason; };
    exception AcknowledgeAlarms { string reason; };
    exception UnacknowledgeAlarms { string reason; };
    exception CommentAlarms { string reason; };
    exception ClearAlarms { string reason; };
    exception GetAlarmList { string reason; };
    exception GetAlarmCount { string reason; };
    exception NextAlarmInformations { string reason; };
    exception FilterComplexityLimit { string reason; };

    /*
    The AlarmInformationIterator is used to iterate through a snapshot of
    Alarm Informations taken from the Alarm List when IRPManager invokes
    get_alarm_list. IRPManager uses it to pace the return of Alarm
    Informations.
    IRPAgent controls the life-cycle of the iterator. However, a destroy
    operation is provided to handle the case where IRPManager wants to stop
    the iteration procedure before reaching the last iteration.
    */
    interface AlarmInformationIterator
    {
        /*
        This method returns between 1 and "how_many" Alarm Informations. The
        IRPAgent may return less than "how_many" items even if there are more
        items to return. "how_many" must be non-zero. Return TRUE if there may
        be more Alarm Information to return. Return FALSE if there are no more
        Alarm Information to be returned.
        If FALSE is returned, the IRPAgent will automatically destroy the
        iterator.
        */
        boolean next_alarm_informations (
            in unsigned short how_many,
            out AlarmIRPConstDefs::AlarmInformationSeq alarm_informations
        )
        raises (NextAlarmInformations, ManagedGenericIRPSystem::InvalidParameter);
    }
}
/*

```

```

    This method destroys the iterator.
    */
    void destroy();
};

interface AlarmIRP
{
    /*
    Return the list of all supported Alarm IRP versions.
    Implementations are to provide a return value consisting of one or more
    IRPVersions.
    Each IRPVersion is defined by the rule in the clause titled
    "IRP document version number string"
    */
    ManagedGenericIRPConstDefs::VersionNumberSet get_alarm_irp_versions (
    )
    raises (GetAlarmIRPVersions);

    /*
    Return the list of all supported operations and their supported
    parameters for a specific Alarm IRP version.
    */
    ManagedGenericIRPConstDefs::MethodList get_alarm_irp_operations_profile (
        in ManagedGenericIRPConstDefs::VersionNumber alarm_irp_version
    )
    raises (GetAlarmIRPOperationsProfile,
        ManagedGenericIRPSystem::OperationNotSupported,
        ManagedGenericIRPSystem::InvalidParameter);

    /*
    Return the list of all supported notifications and their supported
    parameters for a specific Alarm IRP version.
    */
    ManagedGenericIRPConstDefs::MethodList get_alarm_irp_notification_profile
    (
        in ManagedGenericIRPConstDefs::VersionNumber alarm_irp_version
    )
    raises (GetAlarmIRPNotificationProfile,
        ManagedGenericIRPSystem::OperationNotSupported,
        ManagedGenericIRPSystem::InvalidParameter);

    /*
    Request to acknowledge one or more alarms.
    */
    ManagedGenericIRPConstDefs::Signal acknowledge_alarms (
        in AlarmIRPConstDefs::AlarmInformationIdAndSeq
        alarm_information_id_and_seq_list,
        in string ack_user_id,
        in ManagedGenericIRPConstDefs::StringOpt ack_system_id,
        out AlarmIRPConstDefs::BadAcknowledgeAlarmInfoSeq
        bad_ack_alarm_info_list
    )
    raises (AcknowledgeAlarms, ManagedGenericIRPSystem::ParameterNotSupported,
        ManagedGenericIRPSystem::InvalidParameter);

    /*
    Request to remove acknowledgement information of one or more alarms.
    */
    ManagedGenericIRPConstDefs::Signal unacknowledge_alarms (
        in AlarmIRPConstDefs::AlarmInformationIdSeq alarm_information_id_list,
        in string ack_user_id,
        in ManagedGenericIRPConstDefs::StringOpt ack_system_id,
        out AlarmIRPConstDefs::BadAlarmInformationIdSeq
        bad_alarm_information_id_list
    )
    raises (UnacknowledgeAlarms,
        ManagedGenericIRPSystem::OperationNotSupported,
        ManagedGenericIRPSystem::ParameterNotSupported,
        ManagedGenericIRPSystem::InvalidParameter);

    /*
    Make comment to one or more alarms.
    */
    ManagedGenericIRPConstDefs::Signal comment_alarms (
        in AlarmIRPConstDefs::AlarmInformationIdSeq alarm_information_id_list,
        in string comment_user_id,
        in ManagedGenericIRPConstDefs::StringOpt comment_system_id,
        in string comment_text,

```

```

        out AlarmIRPConstDefs::BadAlarmInformationIdSeq
        bad_alarm_information_id_list
    )
    raises (CommentAlarms, ManagedGenericIRPSystem::OperationNotSupported,
           ManagedGenericIRPSystem::ParameterNotSupported,
           ManagedGenericIRPSystem::InvalidParameter);

    /*
    Request to clear one or more alarms.
    */
    ManagedGenericIRPConstDefs::Signal clear_alarms (
        in AlarmIRPConstDefs::AlarmInformationIdSeq alarm_information_id_list,
        in string clear_user_id,
        in ManagedGenericIRPConstDefs::StringOpt clear_system_id,
        out AlarmIRPConstDefs::BadAlarmInformationIdSeq
        bad_alarm_information_id_list
    )
    raises (ClearAlarms, ManagedGenericIRPSystem::OperationNotSupported,
           ManagedGenericIRPSystem::ParameterNotSupported,
           ManagedGenericIRPSystem::InvalidParameter);

    /*
    This method returns Alarm Informations.
    If flag is TRUE, all returned Alarm Informations shall be
    in AlarmInformationSeq that contains 0 or more Alarm Informations.
    Output parameter iter shall be useless.
    If flag is FALSE, no Alarm Informations shall be in AlarmInformationSeq.
    IRPagent needs to use iter to retrieve them.
    */
    AlarmIRPConstDefs::AlarmInformationSeq get_alarm_list (
        in ManagedGenericIRPConstDefs::StringOpt filter,
        in AlarmIRPConstDefs::DNOpt base_object,
        out boolean flag,
        out AlarmInformationIterator iter
    )
    raises (GetAlarmList, FilterComplexityLimit, ManagedGenericIRPSystem::ParameterNotSupported,
           ManagedGenericIRPSystem::InvalidParameter);

    /*
    This method returns the count of Alarm Informations.
    */
    void get_alarm_count (
        in ManagedGenericIRPConstDefs::StringOpt filter,
        out unsigned long critical_count,
        out unsigned long major_count,
        out unsigned long minor_count,
        out unsigned long warning_count,
        out unsigned long indeterminate_count,
        out unsigned long cleared_count
    )
    raises (GetAlarmCount, FilterComplexityLimit, ManagedGenericIRPSystem::OperationNotSupported,
           ManagedGenericIRPSystem::ParameterNotSupported,
           ManagedGenericIRPSystem::InvalidParameter);
};

};

#endif // _ALARM_IRP_SYSTEM_IDL_

```

A.3.4 IDL specification "AlarmIRPNotifications.idl"

```

//File: AlarmIRPNotifications.idl
#ifndef _ALARM_IRP_NOTIFICATIONS_IDL_
#define _ALARM_IRP_NOTIFICATIONS_IDL_

#include <AlarmIRPConstDefs.idl>
#include <NotificationIRPNotifications.idl>

// This statement must appear after all include statements
#pragma prefix "3gppsa5.org"

/* ## Module: AlarmIRPNotifications
This module contains notifications for Alarm IRP
=====
*/

```

```

module AlarmIRPNotifications
{
    interface NotifyNewAlarm: NotificationIRPNotifications::Notify
    {
        const string EVENT_TYPE = "notifyNewAlarm";

        /**
         * This constant defines the name of the probableCause property.
         * The data type for the value of this property
         * is short.
         */
        const string PROBABLE_CAUSE =
            AlarmIRPConstDefs::AttributeNameValue::PROBABLE_CAUSE;

        /**
         * This constant defines the name of the
         * perceivedSeverity property.
         * The data type for the value of this property
         * is short.
         */
        const string PERCEIVED_SEVERITY =
            AlarmIRPConstDefs::AttributeNameValue::PERCEIVED_SEVERITY;

        /**
         * This constant defines the name of the specificProblem
         * property. The data type for the value of this property
         * is string.
         */
        const string SPECIFIC_PROBLEM =
            AlarmIRPConstDefs::AttributeNameValue::SPECIFIC_PROBLEM;

        /**
         * The two constants defines the name of the additionalInformation
         * property (the vendor-specific (VS) perceived severity and alarm type).
         * The data type for the value of this property
         * is string.
         */
        const string AI_VS_PERCEIVED_SEVERITY =
            AlarmIRPConstDefs::AdditionalInformation::AI_VS_PERCEIVED_SEVERITY;
        const string AI_VS_ALARM_TYPE =
            AlarmIRPConstDefs::AdditionalInformation::AI_VS_ALARM_TYPE;

        /**
         * This constant defines the name of the
         * rootCauseIndicator property.
         * The data type for the value of this property
         * is AlarmIRPConstDefs::RootCauseIndicator.
         */
        const string ROOT_CAUSE_INDICATOR =
            AlarmIRPConstDefs::AttributeNameValue::ROOT_CAUSE_INDICATOR;

        /**
         * This constant defines the name of the
         * correlatedNotifications property.
         * The data type for the value of this property
         * is AlarmIRPConstDefs::CorrelatedNotificationSet.
         */
        const string CORRELATED_NOTIFICATIONS =
            AlarmIRPConstDefs::AttributeNameValue::
                CORRELATED_NOTIFICATIONS;

        /**
         * This constant defines the name of the
         * backedUpStatus property.
         * The data type for the value of this property
         * is AlarmIRPConstDefs::BackedUpStatus.
         */
        const string BACKED_UP_STATUS =
            AlarmIRPConstDefs::AttributeNameValue::BACKED_UP_STATUS;

        /**
         * This constant defines the name of the backUpObject property.
         * The data type for the value of this property
         * is a string carrying of DN of the back-up object.
         */
    }
}

```

```
const string BACK_UP_OBJECT =
    AlarmIRPCConstDefs::AttributeNameValue::BACK_UP_OBJECT;

/**
 * This constant defines the name of the
 * trendIndication property.
 * The data type for the value of this property
 * is AlarmIRPCConstDefs::TrendIndication.
 */
const string TREND_INDICATION =
    AlarmIRPCConstDefs::AttributeNameValue::TREND_INDICATION;

/**
 * This constant defines the name of the thresholdInfo property.
 * The data type for the value of this property
 * is AlarmIRPCConstDefs::ThresholdInfo.
 */
const string THRESHOLD_INFO =
    AlarmIRPCConstDefs::AttributeNameValue::THRESHOLD_INFO;

/**
 * This constant defines the name of the
 * stateChangeDefinition property.
 * The data type for the value of this property
 * is AlarmIRPCConstDefs::AttributeChangeSet.
 */
const string STATE_CHANGE_DEFINITION =
    AlarmIRPCConstDefs::AttributeNameValue::STATE_CHANGE_DEFINITION;

/**
 * This constant defines the name of the
 * monitoredAttributes property.
 * The data type for the value of this property
 * is AlarmIRPCConstDefs::AttributeSet.
 */
const string MONITORED_ATTRIBUTES =
    AlarmIRPCConstDefs::AttributeNameValue::MONITORED_ATTRIBUTES;

/**
 * This constant defines the name of the
 * proposedRepairActions property.
 * The data type for the value of this property
 * is string.
 */
const string PROPOSED_REPAIR_ACTIONS =
    AlarmIRPCConstDefs::AttributeNameValue::PROPOSED_REPAIR_ACTIONS;

/**
 * This constant defines the name of the additionalText
 * property.
 * The data type for the value of this property
 * is string.
 */
const string ADDITIONAL_TEXT =
    AlarmIRPCConstDefs::AttributeNameValue::ADDITIONAL_TEXT;

/**
 * This constant defines the name of the alarmId property.
 * The data type for the value of this property
 * is string. If the string is a zero-length string or if
 * this NV pair is absent, the default semantics is that
 * alarmId is a concatenation of
 * managedObjectInstance, eventType, probableCause and
 * specificProblem, if present, of this Structured Event.
 * Since probableCause is encoded as a short, it shall be
 * converted into string before concatenation.
 * The resultant string shall not contain spaces.
 */
const string ALARM_ID =
    AlarmIRPCConstDefs::AttributeNameValue::ALARM_ID;

/**
 * This constant defines the name of the serviceUser property.
 * The data type for the value of this property
 * is string.
 */
const string SERVICE_USER =
    AlarmIRPCConstDefs::AttributeNameValue::SERVICE_USER;
```

```
/**
 * This constant defines the name of the serviceProvider
 * property.
 * The data type for the value of this property
 * is string.
 */
const string SERVICE_PROVIDER =
    AlarmIRPConstDefs::AttributeNameValue::SERVICE_PROVIDER;

/**
 * This constant defines the name of the
 * securityAlarmDetector property.
 * The data type for the value of this property
 * is string.
 */
const string SECURITY_ALARM_DETECTOR =
    AlarmIRPConstDefs::AttributeNameValue::SECURITY_ALARM_DETECTOR;
};

interface NotifyAckStateChanged:
    NotificationIRPNotifications::Notify
{
    const string EVENT_TYPE = "notifyAckStateChanged";

    const string PROBABLE_CAUSE =
        AlarmIRPConstDefs::AttributeNameValue::PROBABLE_CAUSE;

    const string PERCEIVED_SEVERITY =
        AlarmIRPConstDefs::AttributeNameValue::PERCEIVED_SEVERITY;

    const string ALARM_ID =
        AlarmIRPConstDefs::AttributeNameValue::ALARM_ID;

    /**
     * This constant defines the name of the ackTime property.
     * The data type for the value of this property
     * is ManagedGenericIRPConstDefs::IRPTime.
     */
    const string ACK_TIME =
        AlarmIRPConstDefs::AttributeNameValue::ACK_TIME;

    const string ACK_USER_ID =
        AlarmIRPConstDefs::AttributeNameValue::ACK_USER_ID;

    const string ACK_SYSTEM_ID =
        AlarmIRPConstDefs::AttributeNameValue::ACK_SYSTEM_ID;

    const string ACK_STATE =
        AlarmIRPConstDefs::AttributeNameValue::ACK_STATE;
};

interface NotifyClearedAlarm: NotificationIRPNotifications::Notify
{
    const string EVENT_TYPE = "notifyClearedAlarm";

    const string PROBABLE_CAUSE =
        AlarmIRPConstDefs::AttributeNameValue::PROBABLE_CAUSE;

    const string PERCEIVED_SEVERITY =
        AlarmIRPConstDefs::AttributeNameValue::PERCEIVED_SEVERITY;

    const string ALARM_ID =
        AlarmIRPConstDefs::AttributeNameValue::ALARM_ID;

    const string CLEAR_USER_ID =
        AlarmIRPConstDefs::AttributeNameValue::CLEAR_USER_ID;

    const string CLEAR_SYSTEM_ID =
        AlarmIRPConstDefs::AttributeNameValue::CLEAR_SYSTEM_ID;
};

interface NotifyAlarmListRebuilt:
    NotificationIRPNotifications::Notify
{
    const string EVENT_TYPE = "notifyAlarmListRebuilt";

    const string REASON =
```

```
    AlarmIRPConstDefs::AttributeNameValue::REASON;

    const string ALARM_LIST_ALIGNMENT_REQUIREMENT =
        AlarmIRPConstDefs::AttributeNameValue::
            ALARM_LIST_ALIGNMENT_REQUIREMENT;
};

interface NotifyChangedAlarm: NotificationIRPNotifications::Notify
{
    const string EVENT_TYPE = "notifyChangedAlarm";

    const string PROBABLE_CAUSE =
        AlarmIRPConstDefs::AttributeNameValue::PROBABLE_CAUSE;

    const string PERCEIVED_SEVERITY =
        AlarmIRPConstDefs::AttributeNameValue::PERCEIVED_SEVERITY;

    const string ALARM_ID =
        AlarmIRPConstDefs::AttributeNameValue::ALARM_ID;
};

interface NotifyComments: NotificationIRPNotifications::Notify
{
    const string EVENT_TYPE = "notifyComments";

    const string PROBABLE_CAUSE =
        AlarmIRPConstDefs::AttributeNameValue::PROBABLE_CAUSE;

    const string PERCEIVED_SEVERITY =
        AlarmIRPConstDefs::AttributeNameValue::PERCEIVED_SEVERITY;

    const string ALARM_ID =
        AlarmIRPConstDefs::AttributeNameValue::ALARM_ID;

    /**
     * This constant defines the name of the comments property.
     * The data type for the value of this property
     * is AlarmIRPConstDefs::CommentSet.
     */
    const string COMMENTS =
        AlarmIRPConstDefs::AttributeNameValue::COMMENTS;
};

interface NotifyPotentialFaultyAlarmList:
NotificationIRPNotifications::Notify
{
    const string EVENT_TYPE = "notifyPotentialFaultyAlarmList";

    /**
     * This constant defines the name of the reason property.
     * The data type for the value of this property
     * is string.
     */
    const string REASON =
        AlarmIRPConstDefs::AttributeNameValue::REASON;
};

interface NotifyCorrelatedNotificationChanged:
NotificationIRPNotifications::Notify
{
    const string EVENT_TYPE = "notifyCorrelatedNotificationChanged";

    const string CORRELATED_NOTIFICATIONS =
        AlarmIRPConstDefs::AttributeNameValue::
            CORRELATED_NOTIFICATIONS;

    const string ALARM_ID =
        AlarmIRPConstDefs::AttributeNameValue::ALARM_ID;

    const string ROOT_CAUSE_INDICATOR =
        AlarmIRPConstDefs::AttributeNameValue::ROOT_CAUSE_INDICATOR;
};

};

#endif // _ALARM_IRP_NOTIFICATIONS_IDL_
```

Annex B (normative): XML Definitions

This annex contains the XML Definitions for the Alarm Integration Reference Point (Alarm IRP) as it applies to Itf-N, in accordance with Alarm IRP IS definitions [4] as well as Notification Log IRP XML Definitions [13].

Apart from being used for the Notification Log, the XML definitions for Alarm IRP notifications are also used by the Alarm IRP SOAP SS.

B.1 Architectural Features

The overall architectural feature of Alarm IRP is specified in 3G TS 32.111-2 [4]. This clause specifies features that are specific to the XML definitions.

B.1.1 Syntax for Distinguished Names

The syntax of a Distinguished Name is defined in 3GPP TS 32.300 [6].

B.1.2 Notification Services

This annex defines the XML syntax of Alarm IRP notifications that is to be used for the Alarm IRP SOAP Solution Set and in conjunction with Notification Log IRP XML Definitions for Notification Log IRP XML Data File and the NL IRP XML Notification Format [13].

B.1.3 IOC Definitions

This annex defines the XML syntax for the IOC definitions of the Alarm IRP IS [4], which are used by the XML definitions for the Alarm IRP notifications and the Alarm IRP IS operations.

B.2 Mapping

Not present in the current version of this specification.

B.3 Solution Set definitions

B.3.1 XML definition structure

Clause B.3.2 provides a graphical representation of the XML elements.

Clause B.3.3 provides XML definitions of Alarm IRP notifications as defined in [4]. These definitions are to be used for the Alarm IRP SOAP Solution Set and in conjunction with Notification Log IRP XML Definitions for Notification Log IRP XML Data File and the NL IRP XML Notification Format [13], as well as considerations for NL IRP XML File Name Conventions defined therein.

Clause B.3.4 provides XML definitions of Alarm IOC as defined in [4].

B.3.2 Graphical Representation

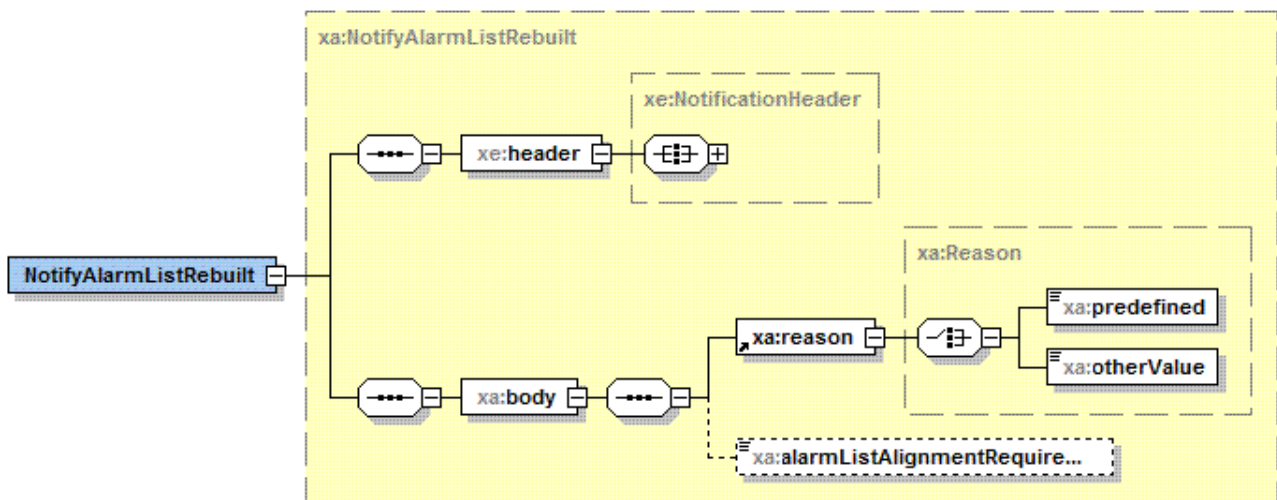
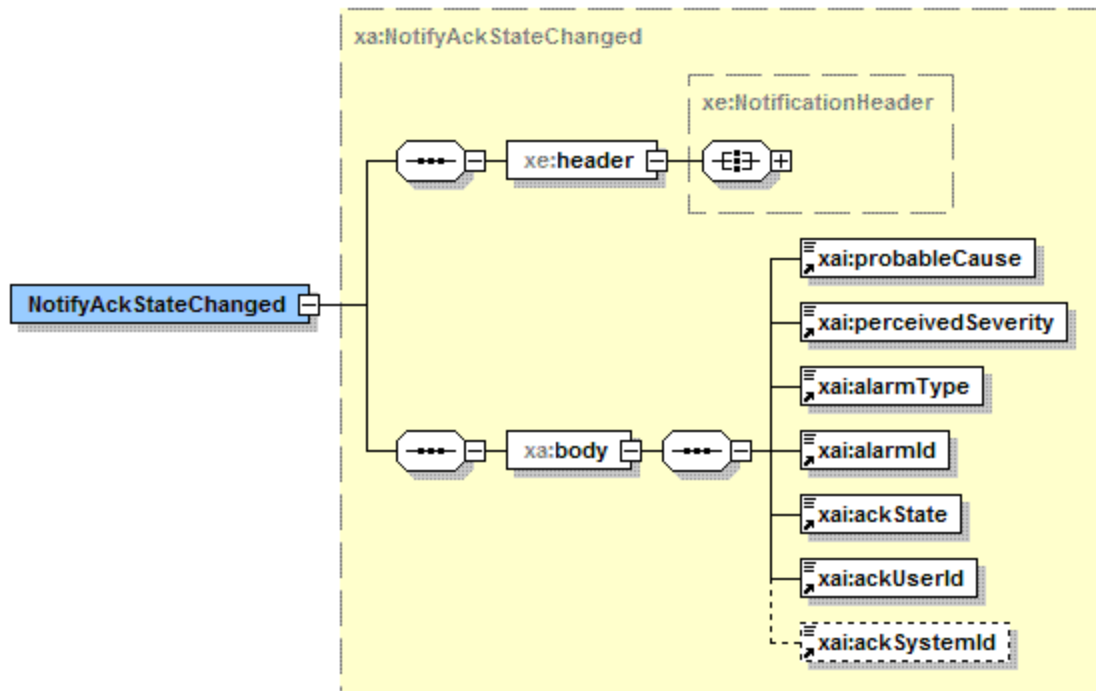

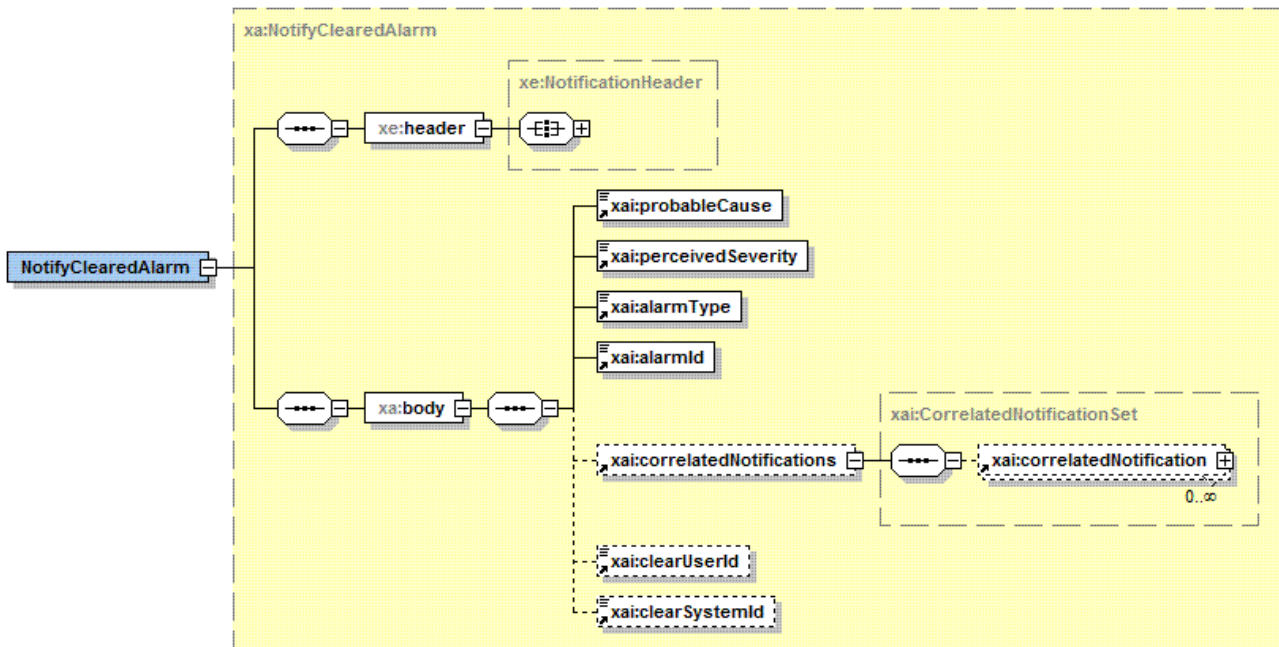
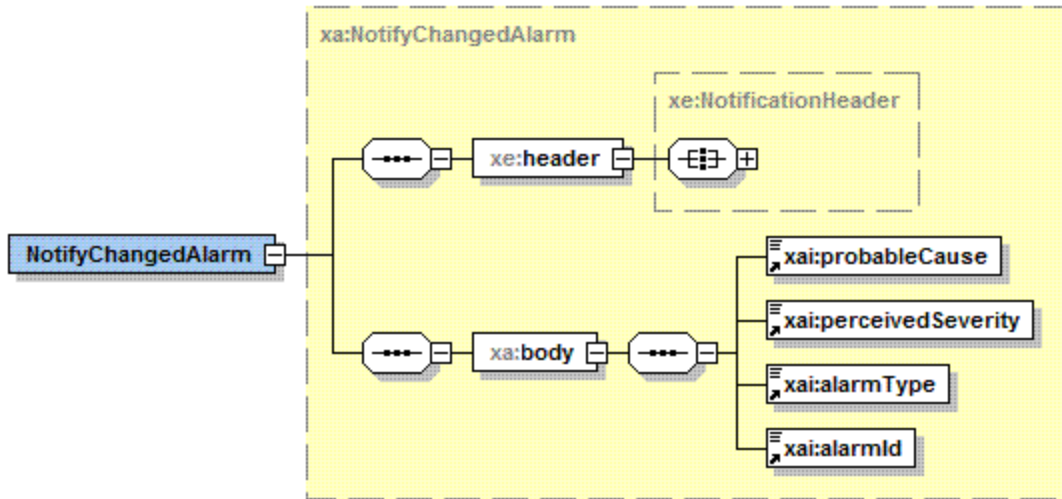

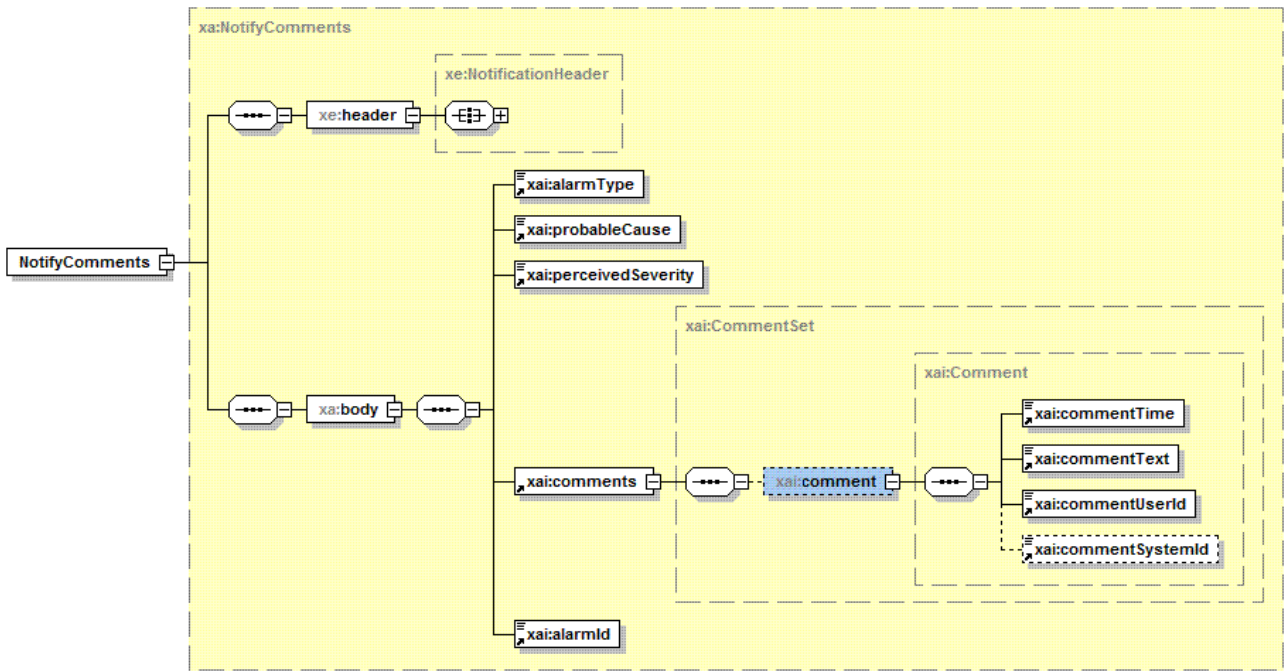

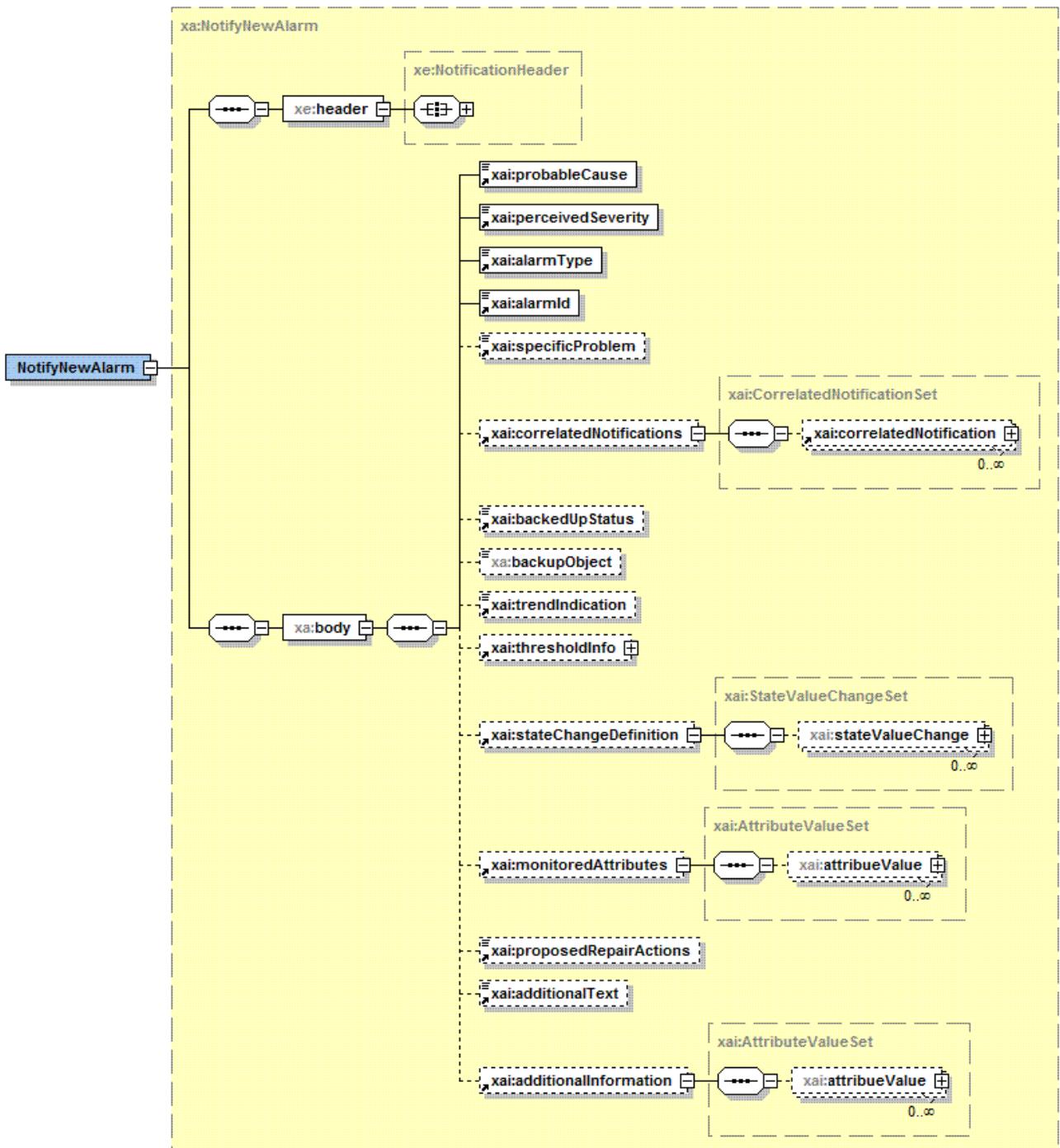

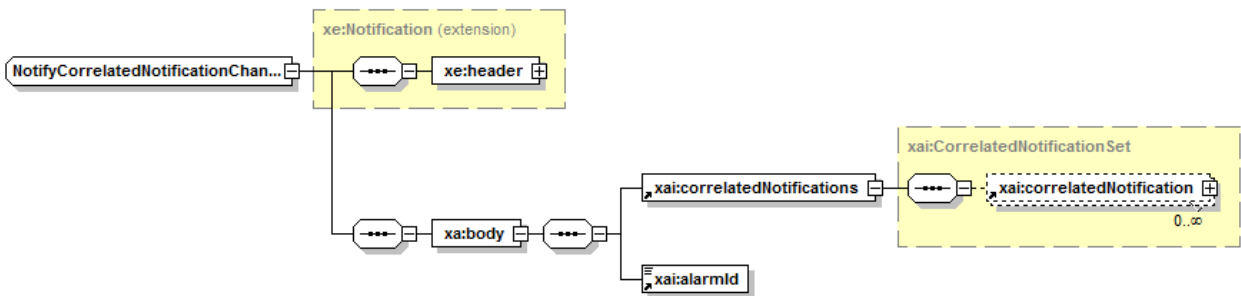
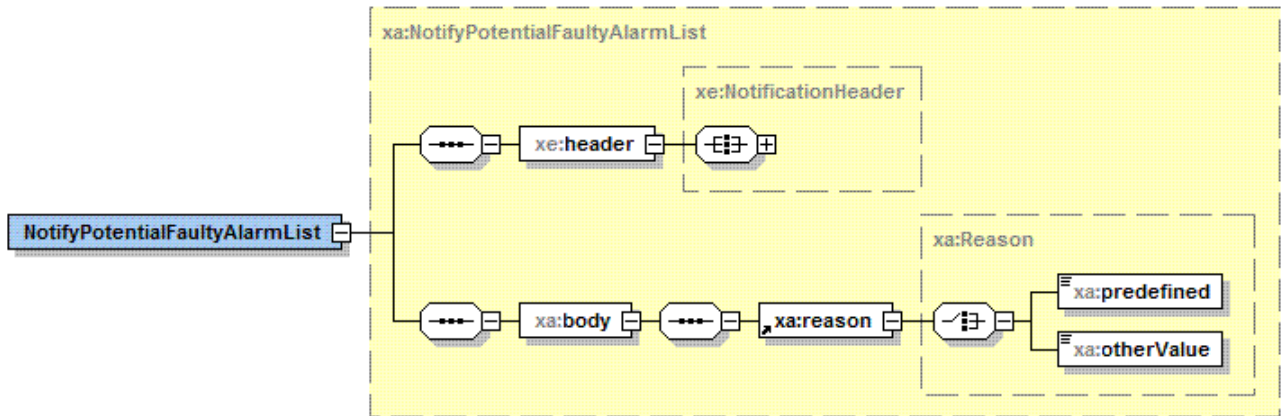
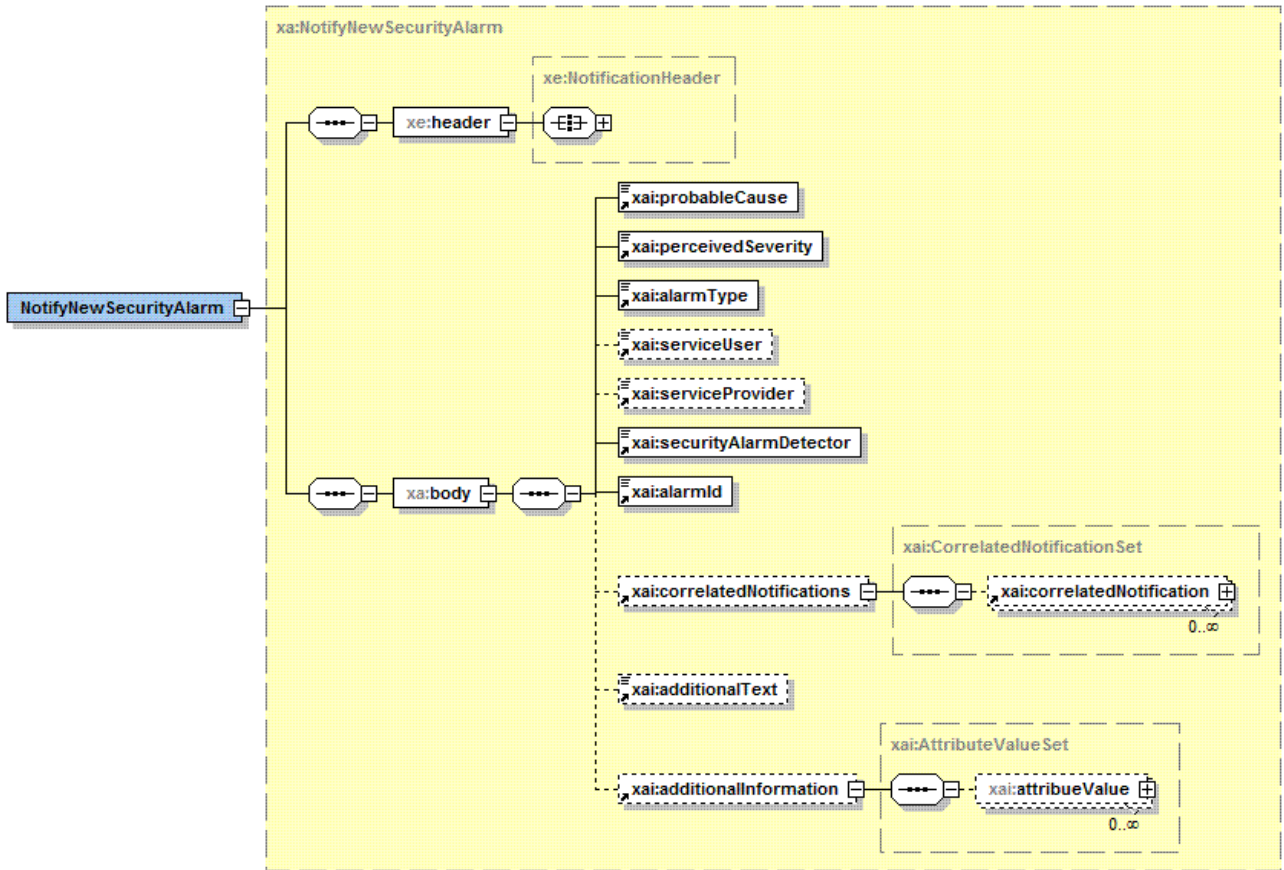

B.3.3 XML Schema “alarmIRPNotif.xsd”

```

<?xml version="1.0" encoding="UTF-8"?>
<!--
  3GPP TS 32.111-6 Alarm IRP Notifications XML Schema
  alarmIRPNotif.xsd
-->
<schema xmlns:xa="http://www.3gpp.org/ftp/specs/archive/32_series/32.111-6#alarmIRPNotif"
  xmlns:xai="http://www.3gpp.org/ftp/specs/archive/32_series/32.111-6#alarmIRPIOCs"
  xmlns:xe="http://www.3gpp.org/ftp/specs/archive/32_series/32.306#notification"
  xmlns:xn="http://www.3gpp.org/ftp/specs/archive/32_series/32.626#genericNrm"
  xmlns:sm="http://www.3gpp.org/ftp/specs/archive/32_series/32.676#stateManagementIRP"
  xmlns="http://www.w3.org/2001/XMLSchema"
  targetNamespace="http://www.3gpp.org/ftp/specs/archive/32_series/32.111-6#alarmIRPNotif"
  elementFormDefault="qualified" attributeFormDefault="unqualified">
  <import namespace="http://www.3gpp.org/ftp/specs/archive/32_series/32.111-6#alarmIRPIOCs"/>
  <import namespace="http://www.3gpp.org/ftp/specs/archive/32_series/32.306#notification"/>
  <import namespace="http://www.3gpp.org/ftp/specs/archive/32_series/32.626#genericNrm"/>
  <import namespace="http://www.3gpp.org/ftp/specs/archive/32_series/32.676#stateManagementIRP"/>
  <simpleType name="AlarmListAlignmentRequirement">
    <restriction base="string">
      <enumeration value="Alignment Required"/>
      <enumeration value="Alignment Not Required"/>
    </restriction>
  </simpleType>
  <simpleType name="AlarmListRebuiltReason">
    <restriction base="string">
      <enumeration value="Agent NE Communications Error"/>
      <enumeration value="Agent Restarts"/>
      <enumeration value="Indeterminate"/>
    </restriction>
  </simpleType>
  <complexType name="Reason">
    <choice>
      <element name="predefined" type="xa:AlarmListRebuiltReason"/>
      <element name="otherValue" type="string"/>
    </choice>
  </complexType>
  <element name="reason" type="xa:Reason"/>
  <complexType name="NotifyAckStateChanged">
    <complexContent>
      <extension base="xe:Notification">
        <sequence>
          <element name="body">
            <complexType>
              <sequence>
                <element ref="xai:probableCause"/>
                <element ref="xai:perceivedSeverity"/>
                <element ref="xai:alarmType"/>
                <element ref="xai:alarmId"/>
                <element ref="xai:ackState"/>
                <element ref="xai:ackUserId"/>
                <element ref="xai:ackSystemId" minOccurs="0"/>
              </sequence>
            </complexType>
          </element>
        </sequence>
      </extension>
    </complexContent>
  </complexType>
  <complexType name="NotifyAlarmListRebuilt">
    <complexContent>
      <extension base="xe:Notification">
        <sequence>
          <element name="body">
            <complexType>
              <sequence>
                <element ref="xa:reason"/>
                <element name="alarmListAlignmentRequirement"
  type="xa:AlarmListAlignmentRequirement" minOccurs="0"/>
              </sequence>
            </complexType>
          </element>
        </sequence>
      </extension>
    </complexContent>
  </complexType>

```

```

</complexType>
<complexType name="NotifyChangedAlarm">
  <complexContent>
    <extension base="xe:Notification">
      <sequence>
        <element name="body">
          <complexType>
            <sequence>
              <element ref="xai:probableCause"/>
              <element ref="xai:perceivedSeverity"/>
              <element ref="xai:alarmType"/>
              <element ref="xai:alarmId"/>
            </sequence>
          </complexType>
        </element>
      </sequence>
    </extension>
  </complexContent>
</complexType>
<complexType name="NotifyClearedAlarm">
  <complexContent>
    <extension base="xe:Notification">
      <sequence>
        <element name="body">
          <complexType>
            <sequence>
              <element ref="xai:probableCause"/>
              <element ref="xai:perceivedSeverity"/>
              <element ref="xai:alarmType"/>
              <element ref="xai:alarmId"/>
              <element ref="xai:correlatedNotifications" minOccurs="0"/>
              <element ref="xai:clearUserId" minOccurs="0"/>
              <element ref="xai:clearSystemId" minOccurs="0"/>
            </sequence>
          </complexType>
        </element>
      </sequence>
    </extension>
  </complexContent>
</complexType>
<complexType name="NotifyComments">
  <complexContent>
    <extension base="xe:Notification">
      <sequence>
        <element name="body">
          <complexType>
            <sequence>
              <element ref="xai:alarmType"/>
              <element ref="xai:probableCause"/>
              <element ref="xai:perceivedSeverity"/>
              <element ref="xai:comments"/>
              <element ref="xai:alarmId"/>
            </sequence>
          </complexType>
        </element>
      </sequence>
    </extension>
  </complexContent>
</complexType>
<complexType name="NotifyNewAlarm">
  <complexContent>
    <extension base="xe:Notification">
      <sequence>
        <element name="body">
          <complexType>
            <sequence>
              <element ref="xai:probableCause"/>
              <element ref="xai:perceivedSeverity"/>
              <element ref="xai:alarmType"/>
              <element ref="xai:alarmId"/>
              <element ref="xai:specificProblem" minOccurs="0"/>
              <element ref="xai:correlatedNotifications" minOccurs="0"/>
              <element ref="xai:backedUpStatus" minOccurs="0"/>
              <element name="backupObject" type="xn:dn" minOccurs="0"/>
              <element ref="xai:trendIndication" minOccurs="0"/>
              <element ref="xai:thresholdInfo" minOccurs="0"/>
              <element ref="xai:stateChangeDefinition" minOccurs="0"/>
              <element ref="xai:monitoredAttributes" minOccurs="0"/>
            </sequence>
          </complexType>
        </element>
      </sequence>
    </extension>
  </complexContent>
</complexType>

```



```

        <element ref="xai:proposedRepairActions" minOccurs="0"/>
        <element ref="xai:additionalText" minOccurs="0"/>
        <element ref="xai:additionalInformation" minOccurs="0"/>
    </sequence>
</complexType>
</element>
</sequence>
</extension>
</complexContent>
</complexType>
<complexType name="NotifyNewSecurityAlarm">
    <complexContent>
        <extension base="xe:Notification">
            <sequence>
                <element name="body">
                    <complexType>
                        <sequence>
                            <element ref="xai:probableCause"/>
                            <element ref="xai:perceivedSeverity"/>
                            <element ref="xai:alarmType"/>
                            <element ref="xai:serviceUser"/>
                            <element ref="xai:serviceProvider"/>
                            <element ref="xai:securityAlarmDetector"/>
                            <element ref="xai:alarmId"/>
                            <element ref="xai:correlatedNotifications" minOccurs="0"/>
                            <element ref="xai:additionalText" minOccurs="0"/>
                            <element ref="xai:additionalInformation" minOccurs="0"/>
                        </sequence>
                    </complexType>
                </element>
            </sequence>
        </extension>
    </complexContent>
</complexType>
<complexType name="NotifyPotentialFaultyAlarmList">
    <complexContent>
        <extension base="xe:Notification">
            <sequence>
                <element name="body">
                    <complexType>
                        <sequence>
                            <element ref="xa:reason"/>
                        </sequence>
                    </complexType>
                </element>
            </sequence>
        </extension>
    </complexContent>
</complexType>
<!-- Notification definitions -->
<complexType name="NotifyCorrelatedNotificationChanged">
    <complexContent>
        <extension base="xe:Notification">
            <sequence>
                <element name="body">
                    <complexType>
                        <sequence>
                            <element ref="xai:correlatedNotifications"/>
                            <element ref="xai:alarmId"/>
                            <element ref="xai:rootCauseIndicator"/>
                        </sequence>
                    </complexType>
                </element>
            </sequence>
        </extension>
    </complexContent>
</complexType>
<element name="NotifyAckStateChanged" type="xa:NotifyAckStateChanged"/>
<element name="NotifyAlarmListRebuilt" type="xa:NotifyAlarmListRebuilt"/>
<element name="NotifyChangedAlarm" type="xa:NotifyChangedAlarm"/>
<element name="NotifyClearedAlarm" type="xa:NotifyClearedAlarm"/>
<element name="NotifyComments" type="xa:NotifyComments"/>
<element name="NotifyNewAlarm" type="xa:NotifyNewAlarm"/>
<element name="NotifyNewSecurityAlarm" type="xa:NotifyNewSecurityAlarm"/>
<element name="NotifyPotentialFaultyAlarmList" type="xa:NotifyPotentialFaultyAlarmList"/>
<element name="NotifyCorrelatedNotificationChanged"
type="xa:NotifyCorrelatedNotificationChanged"/>
</schema>

```

B.3.4 XML Schema “alarmIRPIOCs.xsd”

```

<?xml version="1.0" encoding="UTF-8"?>
<!--
  3GPP TS 32.111-6 Alarm IRP IOC XML Schema
  alarmIRPIOCs.xsd
-->
<schema xmlns:xai="http://www.3gpp.org/ftp/specs/archive/32_series/32.111-6#alarmIRPIOCs"
  xmlns:xe="http://www.3gpp.org/ftp/specs/archive/32_series/32.306#notification"
  xmlns:xn="http://www.3gpp.org/ftp/specs/archive/32_series/32.626#genericNrm"
  xmlns:sm="http://www.3gpp.org/ftp/specs/archive/32_series/32.676#stateManagementIRP"
  xmlns="http://www.w3.org/2001/XMLSchema"
  targetNamespace="http://www.3gpp.org/ftp/specs/archive/32_series/32.111-6#alarmIRPIOCs"
  elementFormDefault="qualified" attributeFormDefault="unqualified">
  <import namespace="http://www.3gpp.org/ftp/specs/archive/32_series/32.306#notification"/>
  <import namespace="http://www.3gpp.org/ftp/specs/archive/32_series/32.626#genericNrm"/>
  <import namespace="http://www.3gpp.org/ftp/specs/archive/32_series/32.676#stateManagementIRP"/>
  <!-- Type definitions -->
  <simpleType name="AckState">
    <restriction base="string">
      <enumeration value="Acknowledged"/>
      <enumeration value="Unacknowledged"/>
    </restriction>
  </simpleType>
  <complexType name="CorrelatedNotification">
    <sequence>
      <element name="source" type="xn:dn"/>
      <element name="notificationIdSet">
        <complexType>
          <sequence>
            <element name="notificationId" type="xe:NotificationId" minOccurs="0"
maxOccurs="unbounded"/>
          </sequence>
        </complexType>
      </element>
    </sequence>
  </complexType>
  <complexType name="CorrelatedNotificationSet">
    <sequence>
      <element ref="xai:correlatedNotification" minOccurs="0" maxOccurs="unbounded"/>
    </sequence>
  </complexType>
  <simpleType name="EventType">
    <restriction base="string">
      <enumeration value="Communications Alarm"/>
      <enumeration value="Processing Error Alarm"/>
      <enumeration value="Environmental Alarm"/>
      <enumeration value="Quality Of Service Alarm"/>
      <enumeration value="Equipment Alarm"/>
      <enumeration value="Integrity Violation"/>
      <enumeration value="Operational Violation"/>
      <enumeration value="Physical Violation"/>
      <enumeration value="Security Service Or Mechanism Violation"/>
      <enumeration value="Time Domain Violation"/>
    </restriction>
  </simpleType>
  <simpleType name="PerceivedSeverity">
    <restriction base="string">
      <enumeration value="Critical"/>
      <enumeration value="Major"/>
      <enumeration value="Minor"/>
      <enumeration value="Warning"/>
      <enumeration value="Indeterminate"/>
      <enumeration value="Cleared"/>
    </restriction>
  </simpleType>
  <simpleType name="ProbableCause">
    <restriction base="string">
      <enumeration value="Indeterminate"/>
      <enumeration value="Alarm Indication Signal"/>
      <enumeration value="Call Setup Failure"/>
      <enumeration value="Degraded Signal"/>
      <enumeration value="Far End Receiver Failure"/>
      <enumeration value="Framing Error"/>
      <enumeration value="Loss Of Frame"/>
      <enumeration value="Loss Of Pointer"/>
    </restriction>
  </simpleType>

```

```
<enumeration value="Loss Of Signal"/>
<enumeration value="Payload Type Mismatch"/>
<enumeration value="Transmission Error"/>
<enumeration value="Remote Alarm Interface"/>
<enumeration value="Excessive Bit Error Rate"/>
<enumeration value="Path Trace Mismatch"/>
<enumeration value="Unavailable"/>
<enumeration value="Signal Label Mismatch"/>
<enumeration value="Loss Of Multi Frame"/>
<enumeration value="Communications Receive Failure"/>
<enumeration value="Communications Transmit Failure"/>
<enumeration value="Modulation Failure"/>
<enumeration value="Demodulation Failure"/>
<enumeration value="Back Plane Failure"/>
<enumeration value="Data Set Problem"/>
<enumeration value="Equipment Identifier Duplication"/>
<enumeration value="External Device Problem"/>
<enumeration value="Line Card Problem"/>
<enumeration value="Multiplexer Problem"/>
<enumeration value="NE Identifier Duplication"/>
<enumeration value="Power Problem"/>
<enumeration value="Processor Problem"/>
<enumeration value="Protection Path Failure"/>
<enumeration value="Receiver Failure"/>
<enumeration value="Replaceable Unit Missing"/>
<enumeration value="Replaceable Unit Type Mismatch"/>
<enumeration value="Synchronization Source Mismatch"/>
<enumeration value="Terminal Problem"/>
<enumeration value="Timing Problem"/>
<enumeration value="Transmitter Failure"/>
<enumeration value="Trunk Card Problem"/>
<enumeration value="Replaceable Unit Problem"/>
<enumeration value="Real Time Clock Failure"/>
<enumeration value="Protection Mechanism Failure"/>
<enumeration value="Protecting Resource Failure"/>
<enumeration value="Air Compressor Failure"/>
<enumeration value="Air Conditioning Failure"/>
<enumeration value="Air Dryer Failure"/>
<enumeration value="Battery Discharging"/>
<enumeration value="Battery Failure"/>
<enumeration value="Commercial Power Failure"/>
<enumeration value="Cooling Fan Failure"/>
<enumeration value="Engine Failure"/>
<enumeration value="Fire Detector Failure"/>
<enumeration value="Fuse Failure"/>
<enumeration value="Generator Failure"/>
<enumeration value="Low Battery Threshold"/>
<enumeration value="Pump Failure"/>
<enumeration value="Rectifier Failure"/>
<enumeration value="Rectifier High Voltage"/>
<enumeration value="Rectifier Low F Voltage"/>
<enumeration value="Ventilation System Failure"/>
<enumeration value="Enclosure Door Open"/>
<enumeration value="Explosive Gas"/>
<enumeration value="Fire"/>
<enumeration value="Flood"/>
<enumeration value="High Humidity"/>
<enumeration value="High Temperature"/>
<enumeration value="High Wind"/>
<enumeration value="Ice Build Up"/>
<enumeration value="Intrusion Detection"/>
<enumeration value="Low Fuel"/>
<enumeration value="Low Humidity"/>
<enumeration value="Low Cable Pressure"/>
<enumeration value="Low Temperature"/>
<enumeration value="Low Water"/>
<enumeration value="Smoke"/>
<enumeration value="Toxic Gas"/>
<enumeration value="External Point Failure"/>
<enumeration value="Storage Capacity Problem"/>
<enumeration value="Memory Mismatch"/>
<enumeration value="Corrupt Data"/>
<enumeration value="Out Of CPU Cycles"/>
<enumeration value="Software Environment Problem"/>
<enumeration value="Software Download Failure"/>
<enumeration value="Loss Of Real Time"/>
<enumeration value="Reinitialized"/>
<enumeration value="Excessive Error Rate"/>
```

```
<enumeration value="Adapter Error"/>
<enumeration value="Application Subsystem Failure"/>
<enumeration value="Bandwidth Reduced"/>
<enumeration value="Communications Protocol Error"/>
<enumeration value="Communications Subsystem Failure"/>
<enumeration value="Configuration Or Customizing Error"/>
<enumeration value="Congestion"/>
<enumeration value="CPU Cycles Limit Exceeded"/>
<enumeration value="Data Set Or Modem Error"/>
<enumeration value="DTE DCE Interface Error"/>
<enumeration value="Equipment Malfunction"/>
<enumeration value="Excessive Vibration"/>
<enumeration value="File Error"/>
<enumeration value="Heating Or Ventilation Or Cooling System Problem"/>
<enumeration value="Humidity Unacceptable"/>
<enumeration value="Input Output Device Error"/>
<enumeration value="Input Device Error"/>
<enumeration value="LAN Error"/>
<enumeration value="Leak Detected"/>
<enumeration value="Local Node Transmission Error"/>
<enumeration value="Material Supply Exhausted"/>
<enumeration value="Out Of Memory"/>
<enumeration value="Output Device Error"/>
<enumeration value="Performance Degraded"/>
<enumeration value="Pressure Unacceptable"/>
<enumeration value="Queue Size Exceeded"/>
<enumeration value="Receive Failure"/>
<enumeration value="Remote Node Transmission Error"/>
<enumeration value="Resource At Or Nearing Capacity"/>
<enumeration value="Response Time Excessive"/>
<enumeration value="Retransmission Rate Excessive"/>
<enumeration value="Software Error"/>
<enumeration value="Software Program Abnormally Terminated"/>
<enumeration value="Software Program Error"/>
<enumeration value="Temperature Unacceptable"/>
<enumeration value="Threshold Crossed"/>
<enumeration value="Toxic Leak Detected"/>
<enumeration value="Transmit Failure"/>
<enumeration value="Underlying Resource Unavailable"/>
<enumeration value="Version Mismatch"/>
<enumeration value="A BIS To BTS Interface Failure"/>
<enumeration value="A BIS To TRX Interface Failure"/>
<enumeration value="Antenna Problem"/>
<enumeration value="Battery Breakdown"/>
<enumeration value="Battery Charging Fault"/>
<enumeration value="Clock Synchronization Problem"/>
<enumeration value="Combiner Problem"/>
<enumeration value="Disk Problem"/>
<enumeration value="Excessive Receiver Temperature"/>
<enumeration value="Excessive Transmitter Output Power"/>
<enumeration value="Excessive Transmitter Temperature"/>
<enumeration value="Frequency Hopping Degraded"/>
<enumeration value="Frequency Hopping Failure"/>
<enumeration value="Frequency Redefinition Failed"/>
<enumeration value="Line Interface Failure"/>
<enumeration value="Link Failure"/>
<enumeration value="Loss Of Synchronization"/>
<enumeration value="Lost Redundancy"/>
<enumeration value="Mains Breakdown With Battery Backup"/>
<enumeration value="Mains Breakdown Without Battery Backup"/>
<enumeration value="Power Supply Failure"/>
<enumeration value="Receiver Antenna Fault"/>
<enumeration value="Receiver Multicoupler Failure"/>
<enumeration value="Reduced Transmitter Output Power"/>
<enumeration value="Signal Quality Evaluation Fault"/>
<enumeration value="Timeslot Hardware Failure"/>
<enumeration value="Transceiver Problem"/>
<enumeration value="Transcoder Problem"/>
<enumeration value="Transcoder Or Rate Adapter Problem"/>
<enumeration value="Transmitter Antenna Failure"/>
<enumeration value="Transmitter Antenna Not Adjusted"/>
<enumeration value="Transmitter Low Voltage Or Current"/>
<enumeration value="Transmitter Off Frequency"/>
<enumeration value="Database Inconsistency"/>
<enumeration value="File System Call Unsuccessful"/>
<enumeration value="Input Parameter Out Of Range"/>
<enumeration value="Invalid Parameter"/>
<enumeration value="Invalid Pointer"/>
```

```

    <enumeration value="Message Not Expected"/>
    <enumeration value="Message Not Initialised"/>
    <enumeration value="Message Out Of Sequence"/>
    <enumeration value="System Call Unsuccessful"/>
    <enumeration value="Timeout Expired"/>
    <enumeration value="Variable Out Of Range"/>
    <enumeration value="Watch Dog Timer Expired"/>
    <enumeration value="Cooling System Failure"/>
    <enumeration value="External Equipment Failure"/>
    <enumeration value="External Power Supply Failure"/>
    <enumeration value="External Transmission Device Failure"/>
    <enumeration value="Reduced Alarm Reporting"/>
    <enumeration value="Reduced Event Reporting"/>
    <enumeration value="Reduced Logging Capability"/>
    <enumeration value="System Resources Overload"/>
    <enumeration value="Broadcast Channel Failure"/>
    <enumeration value="Call Establishment Error"/>
    <enumeration value="Invalid Message Received"/>
    <enumeration value="Invalid MSU Received"/>
    <enumeration value="LAPD Link Protocol Failure"/>
    <enumeration value="Local Alarm Indication"/>
    <enumeration value="Remote Alarm Indication"/>
    <enumeration value="Routing Failure"/>
    <enumeration value="SS7 Protocol Failure"/>
    <enumeration value="Authentication Failure"/>
    <enumeration value="Breach Of Confidentiality"/>
    <enumeration value="Cable Tamper"/>
    <enumeration value="Delayed Information"/>
    <enumeration value="Denial Of Service"/>
    <enumeration value="Duplicate Information"/>
    <enumeration value="Information Missing"/>
    <enumeration value="Information Modification Detected"/>
    <enumeration value="Information Out Of Sequence"/>
    <enumeration value="Key Expired"/>
    <enumeration value="Non Repudiation Failure"/>
    <enumeration value="Out Of Hours Activity"/>
    <enumeration value="Out Of Service"/>
    <enumeration value="Procedural Error"/>
    <enumeration value="Unauthorised Access Attempt"/>
    <enumeration value="Unexpected Information"/>
    <enumeration value="Unspecified Reason"/>
  </restriction>
</simpleType>
<simpleType name="ThresholdIndicator">
  <restriction base="string">
    <enumeration value="Up"/>
    <enumeration value="Down"/>
  </restriction>
</simpleType>
<simpleType name="TrendIndicator">
  <restriction base="string">
    <enumeration value="Less Severe"/>
    <enumeration value="No Change"/>
    <enumeration value="More Severe"/>
  </restriction>
</simpleType>
<simpleType name="AttributeType">
  <restriction base="string">
    <enumeration value="string"/>
    <enumeration value="integer"/>
    <enumeration value="unsignedInt"/>
    <enumeration value="boolean"/>
    <enumeration value="dateTime"/>
    <enumeration value="base64Binary"/>
  </restriction>
</simpleType>
<complexType name="AttributeValue">
  <sequence>
    <element name="attributeName" type="string"/>
    <element name="attributeValue" type="anySimpleType"/>
    <element name="attributeType" type="xai:AttributeType" minOccurs="0"/>
  </sequence>
</complexType>
<complexType name="AttributeValueSet">
  <sequence>
    <element name="attribueValue" type="xai:AttributeValue" minOccurs="0"
maxOccurs="unbounded"/>
  </sequence>

```

```

</complexType>
<complexType name="AttributeValueChange">
  <sequence>
    <element name="attributeName" type="string"/>
    <element name="oldValue" type="anySimpleType"/>
    <element name="newValue" type="anySimpleType"/>
  </sequence>
</complexType>
<complexType name="AttributeValueChangeSet">
  <sequence>
    <element name="attributeValueChange" type="xai:AttributeValueChange" minOccurs="0"
maxOccurs="unbounded"/>
  </sequence>
</complexType>
<complexType name="StateValueChange">
  <sequence>
    <element name="attributeName" type="xai:StateAttributeNames"/>
    <element name="oldValue" type="xai:StateAttributeType" minOccurs="0"/>
    <element name="newValue" type="xai:StateAttributeType"/>
  </sequence>
</complexType>
<simpleType name="StateAttributeNames">
  <restriction base="string">
    <enumeration value="Operational State"/>
    <enumeration value="Usage State"/>
    <enumeration value="Administrative State"/>
    <enumeration value="Alarm Status"/>
    <enumeration value="Procedural Status"/>
    <enumeration value="Availability Status"/>
    <enumeration value="Control Status"/>
    <enumeration value="Standby Status"/>
    <enumeration value="Unknown Status"/>
  </restriction>
</simpleType>
<complexType name="StateAttributeType">
  <choice>
    <element name="operationalState" type="sm:operationalStateType"/>
    <element name="usageState" type="sm:usageStateType"/>
    <element name="administrativeState" type="sm:administrativeStateType"/>
    <element name="alarmStatus" type="sm:alarmStatusType"/>
    <element name="proceduralStatus" type="sm:proceduralStatusType"/>
    <element name="availabilityStatus" type="sm:availabilityStatusType"/>
    <element name="controlStatus" type="sm:controlStatusType"/>
    <element name="standbyStatus" type="sm:standbyStatusType"/>
    <element name="unknownStatus" type="sm:unknownStatusType"/>
  </choice>
</complexType>
<complexType name="StateValueChangeSet">
  <sequence>
    <element name="stateValueChange" type="xai:StateValueChange" minOccurs="0"
maxOccurs="unbounded"/>
  </sequence>
</complexType>
<complexType name="Comment">
  <sequence>
    <element ref="xai:commentTime"/>
    <element ref="xai:commentText"/>
    <element ref="xai:commentUserId"/>
    <element ref="xai:commentSystemId" minOccurs="0"/>
  </sequence>
</complexType>
<complexType name="CommentSet">
  <sequence>
    <element name="comment" type="xai:Comment" minOccurs="0"/>
  </sequence>
</complexType>
<simpleType name="NotificationType">
  <restriction base="string">
    <enumeration value="notifyNewAlarm"/>
    <enumeration value="notifyChangedAlarm"/>
    <enumeration value="notifyClearedAlarm"/>
  </restriction>
</simpleType>
<complexType name="NotificationIdSet">
  <sequence>
    <element name="notificationId" type="xe:NotificationId" minOccurs="0"
maxOccurs="unbounded"/>
  </sequence>

```

```

</complexType>
<complexType name="ThresholdInfo">
  <sequence>
    <element name="attributeId" type="string"/>
    <element name="observedValue" type="float"/>
    <element name="thresholdLevel" type="xai:ThresholdLevel" minOccurs="0"/>
    <element name="armTime" type="dateTime"/>
  </sequence>
</complexType>
<complexType name="ThresholdLevel">
  <sequence>
    <element name="indication" type="xai:ThresholdIndicator"/>
    <element name="low" type="float" minOccurs="0"/>
    <element name="high" type="float"/>
  </sequence>
</complexType>
<!-- Attributes of the AlarmInformation IOC -->
<element name="alarmId" type="string"/>
<element name="alarmRaisedTime" type="dateTime"/>
<element name="alarmClearedTime" type="dateTime"/>
<element name="alarmChangedTime" type="dateTime"/>
<element name="eventType" type="xai:EventType"/>
<element name="alarmType" substitutionGroup="xai:eventType"/>
<element name="probableCause" type="xai:ProbableCause"/>
<element name="perceivedSeverity" type="xai:PerceivedSeverity"/>
<element name="specificProblem" type="string"/>
<element name="backedUpStatus" type="boolean"/>
<element name="trendIndication" type="xai:TrendIndicator"/>
<element name="thresholdInfo" type="xai:ThresholdInfo"/>
<element name="stateChangeDefinition" type="xai:StateValueChangeSet"/>
<element name="monitoredAttributes" type="xai:AttributeValueSet"/>
<element name="proposedRepairActions" type="string"/>
<element name="additionalText" type="string"/>
<element name="additionalInformation" type="xai:AttributeValueSet"/>
<element name="ackTime" type="dateTime"/>
<element name="ackUserId" type="string"/>
<element name="ackSystemId" type="string"/>
<element name="ackState" type="xai:AckState"/>
<element name="clearUserId" type="string"/>
<element name="clearSystemId" type="string"/>
<element name="serviceUser" type="string"/>
<element name="serviceProvider" type="string"/>
<element name="securityAlarmDetector" type="string"/>
<element name="rootCauseIndicator" type="boolean"/>
<!-- AlarmList entity for alarms not related to security -->
<complexType name="NonSecurityAlarm">
  <sequence>
    <element name="notificationType" type="xai:NotificationType"/>
    <element ref="xai:alarmType"/>
    <element ref="xai:objectClass"/>
    <element ref="xai:objectInstance"/>
    <element name="notificationId" type="xe:NotificationId" minOccurs="0"/>
    <element name="eventTime" type="dateTime" minOccurs="0"/>
    <element ref="xn:systemDN" minOccurs="0"/>
    <element ref="xai:alarmId"/>
    <element ref="xai:alarmRaisedTime"/>
    <element ref="xai:alarmClearedTime"/>
    <element ref="xai:alarmChangedTime" minOccurs="0"/>
    <element ref="xai:probableCause"/>
    <element ref="xai:perceivedSeverity"/>
    <element ref="xai:rootCauseIndicator" minOccurs="0"/>
    <element ref="xai:specificProblem" minOccurs="0"/>
    <element ref="xai:backedUpStatus" minOccurs="0"/>
    <element ref="xai:trendIndication" minOccurs="0"/>
    <element ref="xai:thresholdInfo" minOccurs="0"/>
    <element ref="xai:stateChangeDefinition" minOccurs="0"/>
    <element ref="xai:monitoredAttributes" minOccurs="0"/>
    <element ref="xai:proposedRepairActions" minOccurs="0"/>
    <element ref="xai:additionalText" minOccurs="0"/>
    <element ref="xai:additionalInformation" minOccurs="0"/>
    <element ref="xai:ackTime"/>
    <element ref="xai:ackUserId"/>
    <element ref="xai:ackSystemId" minOccurs="0"/>
    <element ref="xai:ackState"/>
    <element ref="xai:clearUserId" minOccurs="0"/>
    <element ref="xai:clearSystemId" minOccurs="0"/>
    <element name="backUpObject" type="xn:dn" minOccurs="0"/>
    <element ref="xai:correlatedNotifications" minOccurs="0"/>
  </sequence>

```

```

        <element ref="xai:comments"/>
    </sequence>
</complexType>
<!-- AlarmList entity for alarms related to security -->
<complexType name="SecurityAlarm">
    <sequence>
        <element name="notificationType" type="xai:NotificationType"/>
        <element ref="xai:alarmType"/>
        <element ref="xai:objectClass"/>
        <element ref="xai:objectInstance"/>
        <element name="notificationId" type="xe:NotificationId" minOccurs="0"/>
        <element name="eventTime" type="dateTime" minOccurs="0"/>
        <element ref="xn:systemDN" minOccurs="0"/>
        <element ref="xai:alarmId"/>
        <element ref="xai:alarmRaisedTime"/>
        <element ref="xai:alarmClearedTime"/>
        <element ref="xai:alarmChangedTime" minOccurs="0"/>
        <element ref="xai:probableCause"/>
        <element ref="xai:perceivedSeverity"/>
        <element ref="xai:rootCauseIndicator" minOccurs="0"/>
        <element ref="xai:specificProblem" minOccurs="0"/>
        <element ref="xai:additionalText" minOccurs="0"/>
        <element ref="xai:additionalInformation" minOccurs="0"/>
        <element ref="xai:ackTime"/>
        <element ref="xai:ackUserId"/>
        <element ref="xai:ackSystemId" minOccurs="0"/>
        <element ref="xai:ackState"/>
        <element ref="xai:clearUserId" minOccurs="0"/>
        <element ref="xai:clearSystemId" minOccurs="0"/>
        <element ref="xai:correlatedNotifications" minOccurs="0"/>
        <element ref="xai:comments"/>
        <element ref="xai:serviceUser"/>
        <element ref="xai:serviceProvider"/>
        <element ref="xai:securityAlarmDetector"/>
    </sequence>
</complexType>
<!-- Attributes of the Comment IOC -->
<element name="commentTime" type="dateTime"/>
<element name="commentText" type="string"/>
<element name="commentUserId" type="string"/>
<element name="commentSystemId" type="string"/>
<!-- A list of comment IOC instances -->
<element name="comments" type="xai:CommentSet"/>
<!-- Attributes of the CorrelatedNotification IOC -->
<element name="source" type="xn:dn"/>
<element name="notificationIdSet" type="xai:NotificationIdSet"/>
<!-- A correlatedNotification IOC instance -->
<element name="correlatedNotification" type="xai:CorrelatedNotification"/>
<!-- A set of correlatedNotification IOC instance -->
<element name="correlatedNotifications" type="xai:CorrelatedNotificationSet"/>
<!-- MonitoredEntity IOC attributes; inherits from Top in order to obtain NRM IOC properties -->
<element name="objectClass" type="string"/>
<element name="objectInstance" type="xn:dn"/>
</schema>

```

Annex C (normative): SOAP Solution Set

This annex specifies the SOAP Solution Set for the IRP whose semantics are specified in Alarm IRP: Information Service (3GPP TS 32.111-2 [4]).

C.1 Architectural features

The overall architectural feature of the Alarm IRP is specified in 3GPP TS 32.111-2 [4]. This clause specifies features that are specific to the SOAP solution set.

C.1.1 Syntax for Distinguished Names

The syntax of a Distinguished Name is defined in 3GPP TS 32.300 [6].

C.1.2 Notification Services

The Alarm IRP SOAP SS uses the Notification IRP SOAP SS of 3GPP TS 32.306 [8]. The IRP Agent shall support the push interface model, which means that the IRP Agent sends alarm notifications to the IRP Manager as soon as new events occur. The IRP Manager does not need to check ("pull") for events.

Relevant definitions are imported from the Alarm IRP XML definitions in Annex B.

C.1.3 Supported W3C specifications

The SOAP 1.1 specification [16] and WSDL 1.1 specification [18] are supported.

The SOAP 1.2 specification [17] is supported optionally.

This specification uses "document" style in WSDL file.

This specification uses "literal" encoding style in WSDL file.

The filter language used in the SS is the XPath Language (see W3C XPath 1.0 specification [19]). IRP Agents may throw a FilterComplexityLimit fault when a given filter is too complex.

C.1.4 Prefixes and namespaces

This specification uses a number of namespace prefixes throughout that are listed in Table C.1.4.

Table C.1.4: Prefixes and Namespaces used in this specification

PREFIX	NAMESPACE
(no prefix)	http://schemas.xmlsoap.org/wsdl/
soap	http://schemas.xmlsoap.org/wsdl/soap/
alarmIRPSystem	http://www.3gpp.org/ftp/specs/archive/32_series/32.111-6#AlarmIRPSystem
alarmIRPData	http://www.3gpp.org/ftp/specs/archive/32_series/32.111-6#AlarmIRPData
xai	http://www.3gpp.org/ftp/specs/archive/32_series/32.111-6#alarmIRPIOCs
xn	http://www.3gpp.org/ftp/specs/archive/32_series/32.626#genericNm
genericIRPSystem	http://www.3gpp.org/ftp/specs/archive/32_series/32.316#GenericIRPSystem
ntfIRPntfSystem	http://www.3gpp.org/ftp/specs/archive/32_series/32.306#NotificationIRPntfSystem

C.2 Mapping

C.2.1 Operation and notification mapping

The Alarm IRP IS (3GPP TS 32.111-2 [4]) defines the operations and their semantics.

Table C.2.1 maps the operations defined in the Alarm IRP IS to their equivalent types, messages, port type operation, and binding operation in this Solution Set (SS).

Table C.2.1 also maps the notifications of the Alarm IRP IS, as well as inherited operations.

Table C.2.1 also qualifies if an operation is Mandatory (M) or Optional (O).

Table C.2.1: Mapping from IS Operation to SS Equivalents

IS Operation in 3GPP TS 32.111-2 [4]	SS: Operation of WSDL port type and WSDL binding	SS: Port of AlarmIRPService	Qualifier
acknowledgeAlarms	acknowledgeAlarms (note 1)	AlarmIRPPort	M
getAlarmList	getAlarmList (note 1)	AlarmIRPPort	M
getAlarmCount	getAlarmCount (note 1)	AlarmIRPPort	O
unacknowledgeAlarms	unacknowledgeAlarms (note 1)	AlarmIRPPort	O
setComment	setComment (note 1)	AlarmIRPPort	O
clearAlarms	clearAlarms (note 1)	AlarmIRPPort	O
notifyNewAlarm	notify (note 2)	NotificationIRPNtfPort	M
notifyAckStateChanged	notify (note 2)	NotificationIRPNtfPort	M
notifyClearedAlarm	notify (note 2)	NotificationIRPNtfPort	M
notifyAlarmListRebuilt	notify (note 2)	NotificationIRPNtfPort	M
notifyChangedAlarm	notify (note 2)	NotificationIRPNtfPort	O
notifyComments	notify (note 2)	NotificationIRPNtfPort	O
notifyPotentialFaultyAlarmList	notify (note 2)	NotificationIRPNtfPort	O
getIRPVersion (note 3)	See TS 32.316 [11]	GenericIRPPort	M
getOperationProfile (note 3)	See TS 32.316 [11]	GenericIRPPort	O
getNotificationProfile (note 3)	See TS 32.316 [11]	GenericIRPPort	O
NOTE 1: The operation is under the port type alarmIRPSystem:AlarmIRPPortType and under the binding alarmIRPSystem:AlarmIRPBinding.			
NOTE 2: The IS equivalent maps to an XML definition specified in Annex B, and this being an input parameter to the operation notify under the port type ntfIRPNtfSystem:NotificationIRPNtf and under the binding ntfIRPNtfSystem:NotificationIRPNtf of 3GPP TS 32.306 [8]. This binding is linked to a port of the AlarmIRPService as indicated in the table above.			
NOTE 3: The IS operation is inherited from the ManagedGenericIRP IOC specified in 3GPP TS 32.312 [10]. This inheritance is by the AlarmIRP IOC of 3GPP TS 32.111-2 [4] inheriting from the ManagedGenericIRP IOC. The corresponding binding is linked to a port of the AlarmIRPService as indicated in the table above.			

C.2.2 Operation parameter mapping

The Alarm IRP IS (3GPP TS 32.111-2 [4]) defines semantics of parameters carried in the operations. The tables below show the mapping of these parameters, as per operation, to their equivalents defined in this SS.

C.2.2.1 Operation `acknowledgeAlarms`

C.2.2.1.1 Input parameters

Table C.2.2.1.1: Mapping from IS `acknowledgeAlarms` input parameters to SS equivalents

IS Operation parameter	SS WSDL type sub-element used in corresponding input message under corresponding port type operation as indicated in Table C.2.1	Qualifier
<code>alarmInformationAndSeverityReferenceList</code>	<code>alarmInformationAndSeverityReferenceList</code>	M
<code>ackUserId</code>	<code>ackUserId</code>	M
<code>ackSystemId</code>	<code>ackSystemId</code>	O

C.2.2.1.2 Output parameters

Table C.2.2.1.2: Mapping from IS `acknowledgeAlarms` output parameters to SS equivalents

IS Operation parameter	SS WSDL type sub-element used in corresponding output message under corresponding port type operation as indicated in Table C.2.1	Qualifier
<code>badAlarmInformationReferenceList</code>	<code>badAlarmInformationReferenceList</code>	M
<code>status</code>	<code>status</code>	M

C.2.2.1.3 Fault definition

Table C.2.2.1.3: Mapping from IS `acknowledgeAlarms` exceptions to SS equivalents

Assertion name	SS WSDL type enumeration value used in corresponding fault message under corresponding port type operation as indicated in Table C.2.1	Qualifier
<code>operation_failed</code>	<code>OperationFailed</code>	M

C.2.2.2 Operation `getAlarmList`

C.2.2.2.1 Input parameters

Table C.2.2.2.1: Mapping from IS `getAlarmList` input parameters to SS equivalents

IS Operation parameter	SS WSDL type sub-element used in corresponding input message under corresponding port type operation as indicated in Table C.2.1	Qualifier
<code>alarmAckState</code>	<code>alarmAckState</code>	O
<code>baseObjectClass</code>	<code>baseObjectClass</code>	O
<code>baseObjectInstance</code>	<code>baseObjectInstance</code>	O
<code>filter</code>	<code>filter</code>	O

C.2.2.2.2 Output parameters

Table C.2.2.2: Mapping from IS `getAlarmList` output parameters to SS equivalents

IS Operation parameter	SS WSDL type sub-element used in corresponding output message under corresponding port type operation as indicated in Table C.2.1	Qualifier
alarmInformationList	alarmInformationList	M
status	status	M

C.2.2.2.3 Fault definition

Table C.2.2.3: Mapping from IS `getAlarmList` exceptions to SS equivalents

Assertion name	SS WSDL type enumeration value used in corresponding fault message under corresponding port type operation as indicated in Table C.2.1	Qualifier
operation_failed	OperationFailed	M
filter_complexity_limit	FilterComplexityLimit	M

C.2.2.3 Operation `getAlarmCount`

C.2.2.3.1 Input parameters

Table C.2.2.3.1: Mapping from IS `getAlarmCount` input parameters to SS equivalents

IS Operation parameter	SS WSDL type sub-element used in corresponding input message under corresponding port type operation as indicated in Table C.2.1	Qualifier
filter	filter	O
alarmAckState	alarmAckState	O

C.2.2.3.2 Output parameters

Table C.2.2.3.2: Mapping from IS `getAlarmCount` output parameters to SS equivalents

IS Operation parameter	SS WSDL type sub-element used in corresponding output message under corresponding port type operation as indicated in Table C.2.1	Qualifier
criticalCount	criticalCount	M
majorCount	majorCount	M
minorCount	minorCount	M
warningCount	warningCount	M
indeterminateCount	indeterminateCount	M
clearedCount	clearedCount	M
status	status	M

C.2.2.3.3 Fault definition

Table C.2.2.3.3: Mapping from IS `getAlarmCount` exceptions to SS equivalents

Assertion name	SS WSDL type enumeration value used in corresponding fault message under corresponding port type operation as indicated in Table C.2.1	Qualifier
operation_failed	OperationFailed	M
filter_complexity_limit	FilterComplexityLimit	M

C.2.2.4 Operation `unacknowledgeAlarms`

C.2.2.4.1 Input parameters

Table C.2.2.4.1: Mapping from IS `unacknowledgeAlarms` input parameters to SS equivalents

IS Operation parameter	SS WSDL type sub-element used in corresponding input message under corresponding port type operation as indicated in Table C.2.1	Qualifier
alarmInformationReferenceList	alarmInformationReferenceList	M
ackUserId	ackUserId	M
ackSystemId	ackSystemId	O

C.2.2.4.2 Output parameters

Table C.2.2.4.2: Mapping from IS `unacknowledgeAlarms` output parameters to SS equivalents

IS Operation parameter	SS WSDL type sub-element used in corresponding output message under corresponding port type operation as indicated in Table C.2.1	Qualifier
badAlarmInformationReferenceList	badAlarmInformationReferenceList	M
status	status	M

C.2.2.4.3 Fault definition

Table C.2.2.4.3: Mapping from IS `unacknowledgeAlarms` exceptions to SS equivalents

Assertion name	SS WSDL type enumeration value used in corresponding fault message under corresponding port type operation as indicated in Table C.2.1	Qualifier
operation_failed	OperationFailed	M

C.2.2.5 Operation `setComment`

C.2.2.5.1 Input parameters

Table C.2.2.5.1: Mapping from IS `setComment` input parameters to SS equivalents

IS Operation parameter	SS WSDL type sub-element used in corresponding input message under corresponding port type operation as indicated in Table C.2.1	Qualifier
<code>alarmInformationReferenceList</code>	<code>alarmInformationReferenceList</code>	M
<code>commentUserId</code>	<code>commentUserId</code>	M
<code>commentSystemId</code>	<code>commentSystemId</code>	O
<code>commentText</code>	<code>commentText</code>	M

C.2.2.5.2 Output parameters

Table C.2.2.5.2: Mapping from IS `setComment` output parameters to SS equivalents

IS Operation parameter	SS WSDL type sub-element used in corresponding output message under corresponding port type operation as indicated in Table C.2.1	Qualifier
<code>badAlarmInformationReferenceList</code>	<code>badAlarmInformationReferenceList</code>	M
<code>status</code>	<code>status</code>	M

C.2.2.5.3 Fault definition

Table C.2.2.5.3: Mapping from IS `setComment` exceptions to SS equivalents

Assertion name	SS WSDL type enumeration value used in corresponding fault message under corresponding port type operation as indicated in Table C.2.1	Qualifier
<code>operation_failed</code>	<code>OperationFailed</code>	M

C.2.2.6 Operation `clearAlarms`

C.2.2.6.1 Input parameters

Table C.2.2.6.1: Mapping from IS `clearAlarms` input parameters to SS equivalents

IS Operation parameter	SS WSDL type sub-element used in corresponding input message under corresponding port type operation as indicated in Table C.2.1	Qualifier
<code>alarmInformationReferenceList</code>	<code>alarmInformationReferenceList</code>	M
<code>clearUserId</code>	<code>clearUserId</code>	M
<code>clearSystemId</code>	<code>clearSystemId</code>	O

C.2.2.6.2 Output parameters

Table C.2.2.6.2: Mapping from IS `clearAlarms` output parameters to SS equivalents

IS Operation parameter	SS WSDL type sub-element used in corresponding output message under corresponding port type operation as indicated in Table C.2.1	Qualifier
badAlarmInformationReferenceList	badAlarmInformationReferenceList	M
status	status	M

C.2.2.6.3 Fault definition

Table C.2.2.6.3: Mapping from IS `clearAlarms` exceptions to SS equivalents

Assertion name	SS WSDL type enumeration value used in corresponding fault message under corresponding port type operation as indicated in Table C.2.1	Qualifier
operation_failed	OperationFailed	M

C.3 Solution Set definitions

C.3.1 WSDL definition structure

Clause C.3.2 provides a graphical representation of the Alarm IRP service.

Clause C.3.3 defines the services which are supported the Alarm IRP agent.

C.3.2 Graphical Representation

The WSDL structure is depicted in Figure C.3.2 below, depicting port type, binding and service. The port type contains port type operations, which again contains input, output and fault messages. The binding contains binding operations, which have the same name as the port type operations. The binding connects to a port inside the service.

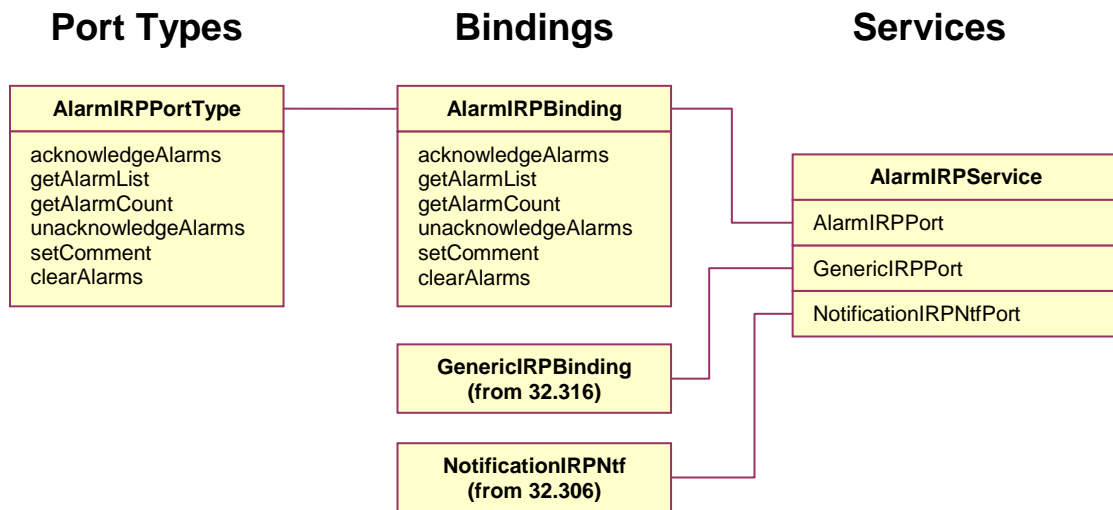

Figure C.3.2: Alarm IRP SOAP Solution Set WSDL structure

C.3.3 WSDL specification "AlarmIRPSystem.wsdl"

```

<?xml version="1.0" encoding="UTF-8"?>
<!--
  3GPP TS 32.111-6 Alarm IRP SOAP Solution Set
-->
<definitions xmlns="http://schemas.xmlsoap.org/wsdl/"
  xmlns:soap="http://schemas.xmlsoap.org/wsdl/soap/"
  xmlns:alarmIRPSystem="http://www.3gpp.org/ftp/specs/archive/32_series/32.111-6#AlarmIRPSystem"
  xmlns:alarmIRPData="http://www.3gpp.org/ftp/specs/archive/32_series/32.111-6#AlarmIRPData"
  xmlns:xai="http://www.3gpp.org/ftp/specs/archive/32_series/32.111-6#alarmIRPIOCs"
  xmlns:xn="http://www.3gpp.org/ftp/specs/archive/32_series/32.626#genericNrm"
  xmlns:genericIRPSystem="http://www.3gpp.org/ftp/specs/archive/32_series/32.316#GenericIRPSystem"
  xmlns:ntfIRPntfSystem="http://www.3gpp.org/ftp/specs/archive/32_series/32.306#NotificationIRPntfSystem"
  targetNamespace="http://www.3gpp.org/ftp/specs/archive/32_series/32.111-6#AlarmIRPSystem">
  <import
    namespace="http://www.3gpp.org/ftp/specs/archive/32_series/32.306#NotificationIRPntfSystem"/>
  <import namespace="http://www.3gpp.org/ftp/specs/archive/32_series/32.316#GenericIRPSystem"/>
  <types>
    <schema targetNamespace="http://www.3gpp.org/ftp/specs/archive/32_series/32.111-6#AlarmIRPData"
      xmlns="http://www.w3.org/2001/XMLSchema">
      <import namespace="http://www.3gpp.org/ftp/specs/archive/32_series/32.111-6#alarmIRPIOCs"/>
      <import namespace="http://www.3gpp.org/ftp/specs/archive/32_series/32.626#genericNrm"/>
      <!-- The following types are defined for the Alarm IRP operations -->
      <simpleType name="AlarmAckState">
        <restriction base="string">
          <enumeration value="AllAlarms"/>
          <enumeration value="AllActiveAlarms"/>
          <enumeration value="AllActiveAndAcknowledgedAlarms"/>
          <enumeration value="AllActiveAndUnacknowledgedAlarms"/>
          <enumeration value="AllClearedAndUnacknowledgedAlarms"/>
          <enumeration value="AllUnacknowledgedAlarms"/>
        </restriction>
      </simpleType>
      <complexType name="AlarmIdAndSeverityElement">
        <sequence>
          <element ref="xai:alarmId"/>
          <element ref="xai:perceivedSeverity" minOccurs="0"/>
        </sequence>
      </complexType>
      <complexType name="AlarmIdAndSeverityList">
        <sequence minOccurs="1" maxOccurs="unbounded">
          <element name="listElement" type="alarmIRPData:AlarmIdAndSeverityElement"/>
        </sequence>
      </complexType>
      <complexType name="AlarmIdList">
        <sequence minOccurs="1" maxOccurs="unbounded">
          <element ref="xai:alarmId"/>
        </sequence>
      </complexType>
      <complexType name="AlarmInformationList">
        <choice minOccurs="0" maxOccurs="unbounded">
          <element name="nonSecurityAlarm" type="xai:NonSecurityAlarm"/>
          <element name="securityAlarm" type="xai:SecurityAlarm"/>
        </choice>
      </complexType>
      <complexType name="BadAcknowledgeAlarmInfoRefElement">
        <sequence>
          <element ref="xai:alarmId"/>
          <element name="failureReason" type="alarmIRPData:FailureReasonBadAck"/>
          <element name="additionalFailureReason" type="string"/>
        </sequence>
      </complexType>
      <complexType name="BadAcknowledgeAlarmInfoRefList">
        <sequence minOccurs="0" maxOccurs="unbounded">
          <element name="listElement"
            type="alarmIRPData:BadAcknowledgeAlarmInfoRefElement"/>
        </sequence>
      </complexType>
      <complexType name="BadClearAlarmInfoRefElement">
        <sequence>
          <element ref="xai:alarmId"/>
          <element name="failureReason" type="string"/>
        </sequence>
      </complexType>

```

```

<complexType name="BadClearAlarmInfoRefList">
  <sequence minOccurs="0" maxOccurs="unbounded">
    <element name="listElement" type="alarmIRPData:BadClearAlarmInfoRefElement"/>
  </sequence>
</complexType>
<complexType name="BadCommentAlarmInfoRefElement">
  <sequence>
    <element ref="xai:alarmId"/>
    <element name="failureReason" type="string"/>
  </sequence>
</complexType>
<complexType name="BadCommentAlarmInfoRefList">
  <sequence minOccurs="0" maxOccurs="unbounded">
    <element name="listElement" type="alarmIRPData:BadCommentAlarmInfoRefElement"/>
  </sequence>
</complexType>
<complexType name="BadUnacknowledgeAlarmInfoRefElement">
  <sequence>
    <element ref="xai:alarmId"/>
    <element name="failureReason" type="string"/>
  </sequence>
</complexType>
<complexType name="BadUnacknowledgeAlarmInfoRefList">
  <sequence minOccurs="0" maxOccurs="unbounded">
    <element name="listElement"
type="alarmIRPData:BadUnacknowledgeAlarmInfoRefElement"/>
  </sequence>
</complexType>
<simpleType name="FailureReasonBadAck">
  <restriction base="string">
    <enumeration value="UnknownAlarmId"/>
    <enumeration value="AcknowledgmentFailed"/>
    <enumeration value="WrongPerceivedSeverity"/>
  </restriction>
</simpleType>
<simpleType name="OperationStatusTwo">
  <restriction base="string">
    <enumeration value="OperationSucceeded"/>
    <enumeration value="OperationFailed"/>
  </restriction>
</simpleType>
<simpleType name="OperationStatusThree">
  <restriction base="string">
    <enumeration value="OperationSucceeded"/>
    <enumeration value="OperationFailed"/>
    <enumeration value="OperationPartiallySucceeded"/>
  </restriction>
</simpleType>
<!-- acknowledgeAlarms Request -->
<element name="acknowledgeAlarms">
  <complexType>
    <sequence>
      <element name="alarmInformationAndSeverityReferenceList"
type="alarmIRPData:AlarmIdAndSeverityList"/>
      <element ref="xai:ackUserId"/>
      <element ref="xai:ackSystemId" minOccurs="0"/>
    </sequence>
  </complexType>
</element>
<!-- acknowledgeAlarms Response -->
<element name="acknowledgeAlarmsResponse">
  <complexType>
    <sequence>
      <element name="badAlarmInformationReferenceList"
type="alarmIRPData:BadAcknowledgeAlarmInfoRefList"/>
      <element name="status" type="alarmIRPData:OperationStatusThree"/>
    </sequence>
  </complexType>
</element>
<!-- acknowledgeAlarms Fault -->
<element name="acknowledgeAlarmsFault">
  <simpleType>
    <restriction base="string">
      <enumeration value="OperationFailed"/>
    </restriction>
  </simpleType>
</element>
<!-- getAlarmList Request -->

```

```

    <element name="getAlarmList">
      <complexType>
        <sequence>
          <element name="alarmAckState" type="alarmIRPData:AlarmAckState"
minOccurs="0"/>
          <element name="baseObjectClass" type="string" minOccurs="0"/>
          <element name="baseObjectInstance" type="xn:dn" minOccurs="0"/>
          <element name="filter" type="string" minOccurs="0"/>
        </sequence>
      </complexType>
    </element>
    <!-- getAlarmList Response -->
    <element name="getAlarmListResponse">
      <complexType>
        <sequence>
          <element name="alarmInformationList"
type="alarmIRPData:AlarmInformationList"/>
          <element name="status" type="alarmIRPData:OperationStatusTwo"/>
        </sequence>
      </complexType>
    </element>
    <!-- getAlarmList Fault -->
    <element name="getAlarmListFault">
      <simpleType>
        <restriction base="string">
          <enumeration value="OperationFailed"/>
          <enumeration value="FilterComplexityLimit"/>
        </restriction>
      </simpleType>
    </element>
    <!-- getAlarmCount Request -->
    <element name="getAlarmCount">
      <complexType>
        <sequence>
          <element name="filter" type="string" minOccurs="0"/>
          <element name="alarmAckState" type="alarmIRPData:AlarmAckState"
minOccurs="0"/>
        </sequence>
      </complexType>
    </element>
    <!-- getAlarmCount Response -->
    <element name="getAlarmCountResponse">
      <complexType>
        <sequence>
          <element name="criticalCount" type="nonNegativeInteger"/>
          <element name="majorCount" type="nonNegativeInteger"/>
          <element name="minorCount" type="nonNegativeInteger"/>
          <element name="warningCount" type="nonNegativeInteger"/>
          <element name="indeterminateCount" type="nonNegativeInteger"/>
          <element name="clearedCount" type="nonNegativeInteger"/>
          <element name="status" type="alarmIRPData:OperationStatusTwo"/>
        </sequence>
      </complexType>
    </element>
    <!-- getAlarmCount Fault -->
    <element name="getAlarmCountFault">
      <simpleType>
        <restriction base="string">
          <enumeration value="OperationFailed"/>
          <enumeration value="FilterComplexityLimit"/>
        </restriction>
      </simpleType>
    </element>
    <!-- unacknowledgeAlarms Request -->
    <element name="unacknowledgeAlarms">
      <complexType>
        <sequence>
          <element name="alarmInformationReferenceList"
type="alarmIRPData:AlarmIdList"/>
          <element ref="xai:ackUserId"/>
          <element ref="xai:ackSystemId" minOccurs="0"/>
        </sequence>
      </complexType>
    </element>
    <!-- unacknowledgeAlarms Response -->
    <element name="unacknowledgeAlarmsResponse">
      <complexType>
        <sequence>

```

```

        <element name="badAlarmInformationReferenceList"
type="alarmIRPData:BadUnacknowledgeAlarmInfoRefList"/>
        <element name="status" type="alarmIRPData:OperationStatusThree"/>
    </sequence>
</complexType>
</element>
<!-- unacknowledgeAlarms Fault -->
<element name="unacknowledgeAlarmsFault">
    <simpleType>
        <restriction base="string">
            <enumeration value="OperationFailed"/>
        </restriction>
    </simpleType>
</element>
<!-- setComment Request -->
<element name="setComment">
    <complexType>
        <sequence>
            <element name="alarmInformationReferenceList"
type="alarmIRPData:AlarmIdList"/>
            <element ref="xai:commentUserId"/>
            <element ref="xai:commentSystemId" minOccurs="0"/>
            <element ref="xai:commentText"/>
        </sequence>
    </complexType>
</element>
<!-- setComment Response -->
<element name="setCommentResponse">
    <complexType>
        <sequence>
            <element name="badAlarmInformationReferenceList"
type="alarmIRPData:BadCommentAlarmInfoRefList"/>
            <element name="status" type="alarmIRPData:OperationStatusThree"/>
        </sequence>
    </complexType>
</element>
<!-- setComment Fault -->
<element name="setCommentFault">
    <simpleType>
        <restriction base="string">
            <enumeration value="OperationFailed"/>
        </restriction>
    </simpleType>
</element>
<!-- clearAlarms Request-->
<element name="clearAlarms">
    <complexType>
        <sequence>
            <element name="alarmInformationReferenceList"
type="alarmIRPData:AlarmIdList"/>
            <element ref="xai:clearUserId"/>
            <element ref="xai:clearSystemId" minOccurs="0"/>
        </sequence>
    </complexType>
</element>
<!-- clearAlarms Response-->
<element name="clearAlarmsResponse">
    <complexType>
        <sequence>
            <element name="badAlarmInformationReferenceList"
type="alarmIRPData:BadClearAlarmInfoRefList"/>
            <element name="status" type="alarmIRPData:OperationStatusThree"/>
        </sequence>
    </complexType>
</element>
<!-- clearAlarms Fault-->
<element name="clearAlarmsFault">
    <simpleType>
        <restriction base="string">
            <enumeration value="OperationFailed"/>
        </restriction>
    </simpleType>
</element>
</schema>
</types>
<message name="acknowledgeAlarms">
    <part name="parameter" element="alarmIRPData:acknowledgeAlarms"/>
</message>

```

```

<message name="acknowledgeAlarmsResponse">
  <part name="parameter" element="alarmIRPData:acknowledgeAlarmsResponse"/>
</message>
<message name="acknowledgeAlarmsFault">
  <part name="parameter" element="alarmIRPData:acknowledgeAlarmsFault"/>
</message>
<message name="getAlarmList">
  <part name="parameter" element="alarmIRPData:getAlarmList"/>
</message>
<message name="getAlarmListResponse">
  <part name="parameter" element="alarmIRPData:getAlarmListResponse"/>
</message>
<message name="getAlarmListFault">
  <part name="parameter" element="alarmIRPData:getAlarmListFault"/>
</message>
<message name="getAlarmCount">
  <part name="parameter" element="alarmIRPData:getAlarmCount"/>
</message>
<message name="getAlarmCountResponse">
  <part name="parameter" element="alarmIRPData:getAlarmCountResponse"/>
</message>
<message name="getAlarmCountFault">
  <part name="parameter" element="alarmIRPData:getAlarmCountFault"/>
</message>
<message name="unacknowledgeAlarms">
  <part name="parameter" element="alarmIRPData:unacknowledgeAlarms"/>
</message>
<message name="unacknowledgeAlarmsResponse">
  <part name="parameter" element="alarmIRPData:unacknowledgeAlarmsResponse"/>
</message>
<message name="unacknowledgeAlarmsFault">
  <part name="parameter" element="alarmIRPData:unacknowledgeAlarmsFault"/>
</message>
<message name="setComment">
  <part name="parameter" element="alarmIRPData:setComment"/>
</message>
<message name="setCommentResponse">
  <part name="parameter" element="alarmIRPData:setCommentResponse"/>
</message>
<message name="setCommentFault">
  <part name="parameter" element="alarmIRPData:setCommentFault"/>
</message>
<message name="clearAlarms">
  <part name="parameter" element="alarmIRPData:clearAlarms"/>
</message>
<message name="clearAlarmsResponse">
  <part name="parameter" element="alarmIRPData:clearAlarmsResponse"/>
</message>
<message name="clearAlarmsFault">
  <part name="parameter" element="alarmIRPData:clearAlarmsFault"/>
</message>
<portType name="AlarmIRPPortType">
  <operation name="acknowledgeAlarms">
    <input message="alarmIRPSystem:acknowledgeAlarms"/>
    <output message="alarmIRPSystem:acknowledgeAlarmsResponse"/>
    <fault name="acknowledgeAlarmsFault" message="alarmIRPSystem:acknowledgeAlarmsFault"/>
  </operation>
  <operation name="getAlarmList">
    <input message="alarmIRPSystem:getAlarmList"/>
    <output message="alarmIRPSystem:getAlarmListResponse"/>
    <fault name="getAlarmListFault" message="alarmIRPSystem:getAlarmListFault"/>
  </operation>
  <operation name="getAlarmCount">
    <input message="alarmIRPSystem:getAlarmCount"/>
    <output message="alarmIRPSystem:getAlarmCountResponse"/>
    <fault name="getAlarmCountFault" message="alarmIRPSystem:getAlarmCountFault"/>
  </operation>
  <operation name="unacknowledgeAlarms">
    <input message="alarmIRPSystem:unacknowledgeAlarms"/>
    <output message="alarmIRPSystem:unacknowledgeAlarmsResponse"/>
    <fault name="unacknowledgeAlarmsFault"
message="alarmIRPSystem:unacknowledgeAlarmsFault"/>
  </operation>
  <operation name="setComment">
    <input message="alarmIRPSystem:setComment"/>
    <output message="alarmIRPSystem:setCommentResponse"/>
    <fault name="setCommentFault" message="alarmIRPSystem:setCommentFault"/>
  </operation>

```

```

        <operation name="clearAlarms">
            <input message="alarmIRPSystem:clearAlarms"/>
            <output message="alarmIRPSystem:clearAlarmsResponse"/>
            <fault name="clearAlarmsFault" message="alarmIRPSystem:clearAlarmsFault"/>
        </operation>
    </portType>
    <binding name="AlarmIRPBinding" type="alarmIRPSystem:AlarmIRPPortType">
        <soap:binding style="document" transport="http://schemas.xmlsoap.org/soap/http"/>
        <operation name="acknowledgeAlarms">
            <soap:operation soapAction="http://www.3gpp.org/ftp/specs/archive/32_series/32.111-
6#acknowledgeAlarms" style="document"/>
            <input>
                <soap:body use="literal"/>
            </input>
            <output>
                <soap:body use="literal"/>
            </output>
            <fault name="acknowledgeAlarmsFault">
                <soap:fault name="acknowledgeAlarmsFault" use="literal"/>
            </fault>
        </operation>
        <operation name="getAlarmList">
            <soap:operation soapAction="http://www.3gpp.org/ftp/specs/archive/32_series/32.111-
6#getAlarmList" style="document"/>
            <input>
                <soap:body use="literal"/>
            </input>
            <output>
                <soap:body use="literal"/>
            </output>
            <fault name="getAlarmListFault">
                <soap:fault name="getAlarmListFault" use="literal"/>
            </fault>
        </operation>
        <operation name="getAlarmCount">
            <soap:operation soapAction="http://www.3gpp.org/ftp/specs/archive/32_series/32.111-
6#getAlarmCount" style="document"/>
            <input>
                <soap:body use="literal"/>
            </input>
            <output>
                <soap:body use="literal"/>
            </output>
            <fault name="getAlarmCountFault">
                <soap:fault name="getAlarmCountFault" use="literal"/>
            </fault>
        </operation>
        <operation name="unacknowledgeAlarms">
            <soap:operation soapAction="http://www.3gpp.org/ftp/specs/archive/32_series/32.111-
6#unacknowledgeAlarms" style="document"/>
            <input>
                <soap:body use="literal"/>
            </input>
            <output>
                <soap:body use="literal"/>
            </output>
            <fault name="unacknowledgeAlarmsFault">
                <soap:fault name="unacknowledgeAlarmsFault" use="literal"/>
            </fault>
        </operation>
        <operation name="setComment">
            <soap:operation soapAction="http://www.3gpp.org/ftp/specs/archive/32_series/32.111-
6#setComment" style="document"/>
            <input>
                <soap:body use="literal"/>
            </input>
            <output>
                <soap:body use="literal"/>
            </output>
            <fault name="setCommentFault">
                <soap:fault name="setCommentFault" use="literal"/>
            </fault>
        </operation>
        <operation name="clearAlarms">
            <soap:operation soapAction="http://www.3gpp.org/ftp/specs/archive/32_series/32.111-
6#clearAlarms" style="document"/>
            <input>
                <soap:body use="literal"/>

```

```
</input>
<output>
  <soap:body use="literal"/>
</output>
<fault name="clearAlarmsFault">
  <soap:fault name="clearAlarmsFault" use="literal"/>
</fault>
</operation>
</binding>
<service name="AlarmIRPService">
  <port name="AlarmIRPPort" binding="alarmIRPSystem:AlarmIRPBinding">
    <soap:address location="http://www.3gpp.org/ftp/specs/archive/32_series/32.111-
6#AlarmIRP"/>
  </port>
  <port name="GenericIRPPort" binding="genericIRPSystem:GenericIRPBinding">
    <soap:address
location="http://www.3gpp.org/ftp/specs/archive/32_series/32.316#GenericIRP"/>
  </port>
  <port name="NotificationIRPNtfPort" binding="ntfIRPNtfSystem:NotificationIRPNtf">
    <soap:address
location="http://www.3gpp.org/ftp/specs/archive/32_series/32.306#NotificationIRPNtf"/>
  </port>
</service>
</definitions>
```

Annex D (informative): Change history

Change history								
Date	TSG #	TSG Doc.	CR	Rev	Subject/Comment	Cat	Old	New
05-2010	SA-48	SP-100284	--	--	Presentation to SA for information and approval	--	---	1.0.0
06-2010	SA-48	--	--	--	Publication	--	1.0.0	10.0.0
09-2010	SA-49	SP-100489	001	--	Correct the qualifier of serviceUser and serviceProvider of NotifyNew SecurityAlarm	F	10.0.0	10.1.0
12-2010	SA-50	SP-100833	002	2	Add alarmChangedTime parameter to the definition of a Structured Event of AlarmInformationSeq - Align with 32.111-2 IS	C	10.1.0	10.2.0
06-2011	SA-52	SP-110289	003	1	Add indication for root cause of alarm	B	10.2.0	10.3.0
06-2011	SA-52	SP-110289	004	1	Add notification for change of alarm correlation data	B	10.2.0	10.3.0
09-2011	SA-53	SP-110534	005	1	Correct definition of rootCauseIndicator of IDL specification	F	10.3.0	10.4.0
09-2012	SA-57	-	-	-	Automatic upgrade from previous Release version 10.4.0	-	10.4.0	11.0.0