

# 3GPP TR 30.302 V7.1.0 (2007-06)

---

*Technical Report*

## **3rd Generation Partnership Project; Technical Specification Group Radio Access Network; 1.28 Mcps TDD Enhanced Uplink; RAN WG2 Stage 2 Decisions (Release 7)**



The present document has been developed within the 3<sup>rd</sup> Generation Partnership Project (3GPP™) and may be further elaborated for the purposes of 3GPP. The present document has not been subject to any approval process by the 3GPP Organizational Partners and shall not be implemented. This Specification is provided for future development work within 3GPP only. The Organizational Partners accept no liability for any use of this Specification. Specifications and reports for implementation of the 3GPP™ system should be obtained via the 3GPP Organizational Partners' Publications Offices.

---

Keywords

---

UMTS, radio, L2, L3, EUL, LCR TDD

**3GPP**

Postal address

---

3GPP support office address

---

650 Route des Lucioles - Sophia Antipolis  
Valbonne - FRANCE  
Tel.: +33 4 92 94 42 00 Fax: +33 4 93 65 47 16

Internet

---

<http://www.3gpp.org>

---

**Copyright Notification**

No part may be reproduced except as authorized by written permission.  
The copyright and the foregoing restriction extend to reproduction in all media.

© 2007, 3GPP Organizational Partners (ARIB, ATIS, CCSA, ETSI, TTA, TTC).  
All rights reserved.

# Contents

Foreword .....	5
1 Scope .....	6
2 References.....	6
3 Definitions, symbols and abbreviations .....	6
3.1 Definitions .....	6
3.2 Abbreviations.....	6
4 Background and Introduction .....	7
5 Requirements.....	7
6 Overall architecture of enhanced uplink DCH .....	8
6.1 Protocol architecture .....	8
6.2 Transport channel attributes .....	8
6.3 Basic physical structure.....	9
6.3.1 UL Physical layer model.....	9
6.3.2 DL Physical layer model.....	9
7 MAC architecture.....	10
7.1 General Principle .....	10
7.1.1 MAC multiplexing .....	10
7.1.2 Reordering entity.....	10
7.2 MAC architecture – UE side .....	10
7.2.1 Overall architecture.....	10
7.2.2 Details of MAC-d .....	11
7.2.3 Details of MAC-c/sh.....	12
7.2.4 Details of MAC-hs .....	12
7.2.5 Details of MAC-es/MAC-e .....	12
7.3 MAC architecture – UTRAN side .....	13
7.3.1 Overall architecture.....	13
7.3.2 Details of MAC-d .....	15
7.3.3 Details of MAC-c/sh.....	16
7.3.4 Details of MAC-hs .....	16
7.3.5 Details of MAC-es .....	16
7.3.6 Details of MAC-e .....	17
8 HARQ protocol.....	18
8.1 General Principle .....	18
8.2 Error handling .....	19
8.3 Signalling .....	20
8.3.1 Uplink.....	20
8.3.2 Downlink .....	20
9 Node B controlled scheduling .....	20
9.1 General Principle .....	20
9.2 UE scheduling operation .....	21
9.2.1 Grants from the Serving Cell .....	21
9.3 Signalling .....	21
9.3.1 Uplink.....	21
9.3.1.1 Information Required for Scheduling .....	21
9.3.1.1.1 Content 21	
9.3.1.1.2 Triggers 21	
9.3.1.1.3 Transmission and Reliability scheme .....	22
9.3.2 Downlink .....	22
10 Non-scheduled transmissions .....	22
11 QoS control .....	23
11.1 General Principle .....	23

11.1.1 QoS configuration principles .....23

11.2 TFC and E-TFC selection .....24

11.3 Setting of Power offset attributes of MAC-d flows .....25

12 Signalling parameters .....25

12.1 Uplink signalling parameters .....25

12.2 Downlink signalling parameters .....25

13 Mobility procedures .....27

**Annex A (informative): Change history .....28**

---

## Foreword

This Technical Report has been produced by the 3rd Generation Partnership Project (3GPP).

The contents of the present document are subject to continuing work within the TSG and may change following formal TSG approval. Should the TSG modify the contents of the present document, it will be re-released by the TSG with an identifying change of release date and an increase in version number as follows:

Version x.y.z

where:

- x the first digit:
  - 1 presented to TSG for information;
  - 2 presented to TSG for approval;
  - 3 or greater indicates TSG approved document under change control.
- y the second digit is incremented for all changes of substance, i.e. technical enhancements, corrections, updates, etc.
- z the third digit is incremented when editorial only changes have been incorporated in the document.

---

## 1 Scope

This document is a Technical Report which captures the Stage 2 decisions on the support of 1.28 Mcps TDD Enhanced Uplink in UTRA.

---

## 2 References

The following documents contain provisions which, through reference in this text, constitute provisions of the present document.

- References are either specific (identified by date of publication, edition number, version number, etc.) or non-specific.
- For a specific reference, subsequent revisions do not apply.
- For a non-specific reference, the latest version applies. In the case of a reference to a 3GPP document (including a GSM document), a non-specific reference implicitly refers to the latest version of that document *in the same Release as the present document*.

- [1] 3GPP TR 25.804: "Feasibility Study on Uplink Enhancements for UTRA TDD".
- [2] 3GPP TR 21.905: "Vocabulary for 3GPP Specifications".
- [3] 3GPP TR 25.309: "FDD Enhanced Uplink; Overall description; Stage 2"
- [4] 3GPP TR 30.301: "3.84 Mcps TDD Enhanced Uplink;"

---

## 3 Definitions, symbols and abbreviations

### 3.1 Definitions

For the purposes of the present document, the following terms and definitions apply.

**Data Description Indicator (DDI): MAC-e header field used to identify the logical channel, MAC-d flow and the size of the MAC-d PDUs concatenated into a MAC-es PDU.**

**E-DCH: Enhanced DCH, a new dedicated transport channel type.**

**Serving E-DCH cell: Cell from which the UE receives Absolute Grants from the Node-B scheduler. A UE has one Serving E-DCH cell.**

- T1: difference between the index of the subframe in which Absolute Grant is received and the index of the subframe in which the UE must transmit/retransmit data, e.g. if an Absolute Grant is received in SubFrame (i) and data must be transmitted/retransmitted in SubFrame (i+3) then T1 = 3.
- T2: difference between the index of the subframe in which a data block is transmitted/retransmitted and the index of the subframe in which ACK/NACK is received for that data block, e.g. if a data block is sent in SubFrame (k) and ACK/NACK is received in SubFrame (k+2) then T2=2.

### 3.2 Abbreviations

For the purposes of the present document, the following abbreviations apply:

AG	Absolute Grant
E-AGCH	E-DCH Absolute Grant Channel
E-HICH	E-DCH HARQ Acknowledgement Indicator Channel
E-PUCH	Enhanced Uplink Physical Channel
E-RNTI	E-DCH Radio Network Temporary Identifier

E-RUCCH	E-DCH Random Access Uplink Control Channel
E-TFC	E-DCH Transport Format Combination
E-UCCH	E-DCH Uplink Control Channel
HARQ	Hybrid Automatic Repeat Request
RSN	Retransmission Sequence Number
TSN	Transmission Sequence Number

---

## 4 Background and Introduction

The technical objective of the work item “1.28Mcps TDD Enhanced Uplink” is to improve the performance of uplink dedicated logical channels, i.e. to increase capacity and throughput and reduce delay. This work item is applicable for UTRA TDD at 1.28 Mcps only.

Of the techniques considered in [1], the following techniques are parts of the work item:

- Node B controlled rate scheduling
- Node-B controlled physical resource scheduling
- Hybrid ARQ
- Higher order modulation

It relies upon a new type of transport channel, the E-DCH which is terminated at the Node B.

---

## 5 Requirements

- The Enhanced Uplink feature shall aim at providing significant enhancements in terms of user experience (throughput and delay) and/or capacity. The coverage is an important aspect of the user experience and it is desirable to allow an operator to provide for consistency of performance across the whole cell area.
- The focus shall be on urban, sub-urban and rural deployment scenarios.
- Full mobility shall be supported, i.e., mobility should be supported for high-speed cases also, but optimisation should be for low-speed to medium-speed scenarios.
- Improvements to the uplink performance of the dedicated logical channels in general are required, with priority given to improving the uplink performance with respect to streaming, interactive and background services. Relevant QoS mechanisms shall allow the support of streaming, interactive and background PS services.
- It is highly desirable to keep the Enhanced Uplink as simple as possible. New techniques or group of techniques shall therefore provide significant incremental gain for an acceptable complexity. The value added per feature/technique shall be considered in the evaluation. It is also desirable to avoid unnecessary options in the specification of the feature.
- The UE and network complexity shall be minimised for a given level of system performance.
- The impact on current releases in terms of both protocol and hardware perspectives shall be taken into account.
- It shall be possible to introduce the Enhanced Uplink feature in a network which has terminals from Release'99, Release 4, Release 5 and Release 6. The Enhanced Uplink feature shall enable significant improvements in overall system performance when operated together with HSDPA. A terminal supporting the Enhanced Uplink feature must support HSDPA.
- Enhancements shall improve uplink performance for 1.28 Mcps TDD. Commonality with the FDD E-DCH feature [3] and the 3.84 Mcps TDD E-DCH feature[4] is desired as long as this does not impair the system performance of 1.28 Mcps TDD.
- Although operation of the enhanced uplink is targeted at cell\_DCH state, it shall be possible to operate enhanced uplink without assigning any dedicated physical resources to a UE.

## 6 Overall architecture of enhanced uplink DCH

### 6.1 Protocol architecture

The following modifications to the existing nodes are needed to support enhanced uplink:

#### UE

A new MAC entity (MAC-es/MAC-e) is added in the UE located below MAC-d. MAC-es/MAC-e in the UE handles HARQ retransmissions, MAC-e multiplexing and E-DCH TFC selection.

#### Node B

A new MAC entity (MAC-e) is added in Node B which handles HARQ retransmissions, scheduling and MAC-e demultiplexing.

#### S-RNC

A new MAC entity (MAC-es) is added in the SRNC to provide in-sequence delivery (reordering).

The resulting protocol architecture is shown in Figure 6.1-1:

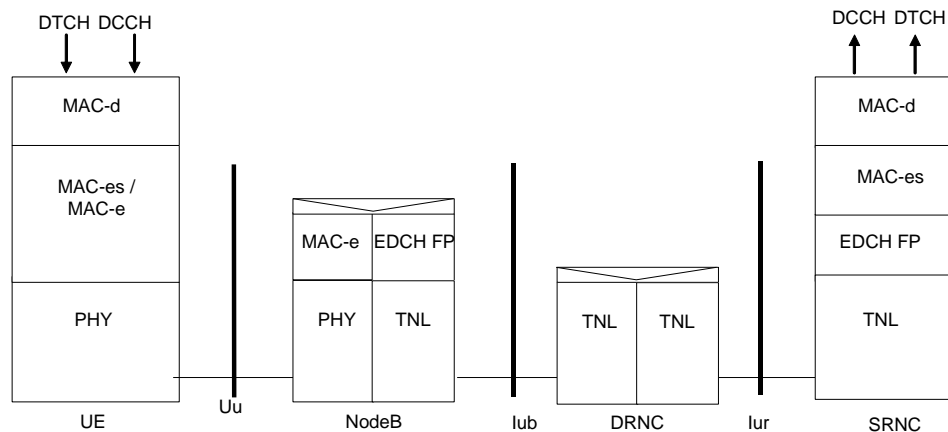

Figure 6.1-1: Protocol Architecture of E-DCH

### 6.2 Transport channel attributes

The E-DCH transport channel has the following characteristics:

- E-DCH uses a separate CCTrCH to any CCTrCHs used to provide DCH (there is no necessity to have a DCH in conjunction with E-DCH)
- There is only one CCTrCH of E-DCH type per UE;
- There is only one E-DCH per CCTrCH of E-DCH type;
- There is only one MAC-e transport block per TTI;
- A 5ms TTI is supported by the E-DCH;



## 6.3 Basic physical structure

### 6.3.1 UL Physical layer model

E-DCH model with DCH and HS-DSCH

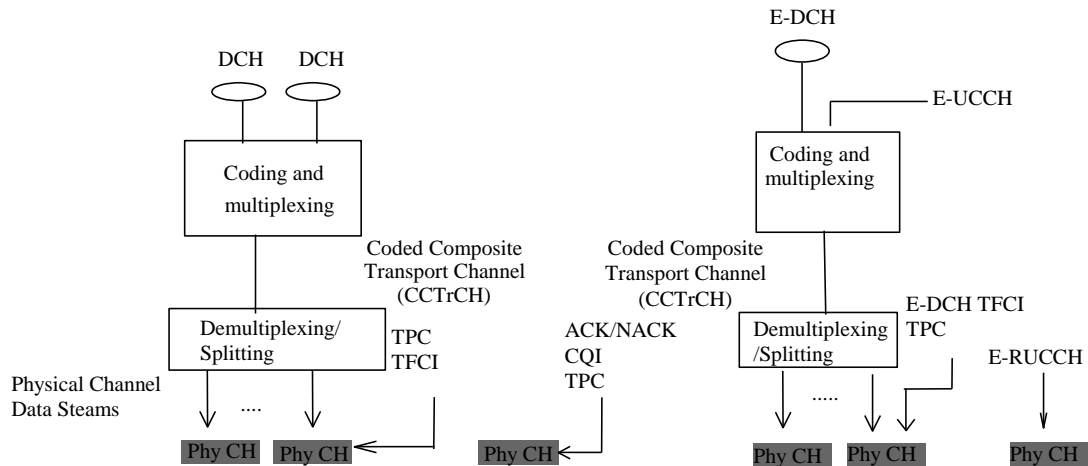

Figure 6.3.1-1: Model of the UE's Uplink physical layer

### 6.3.2 DL Physical layer model

E-DCH model with DCH and HS-DSCH

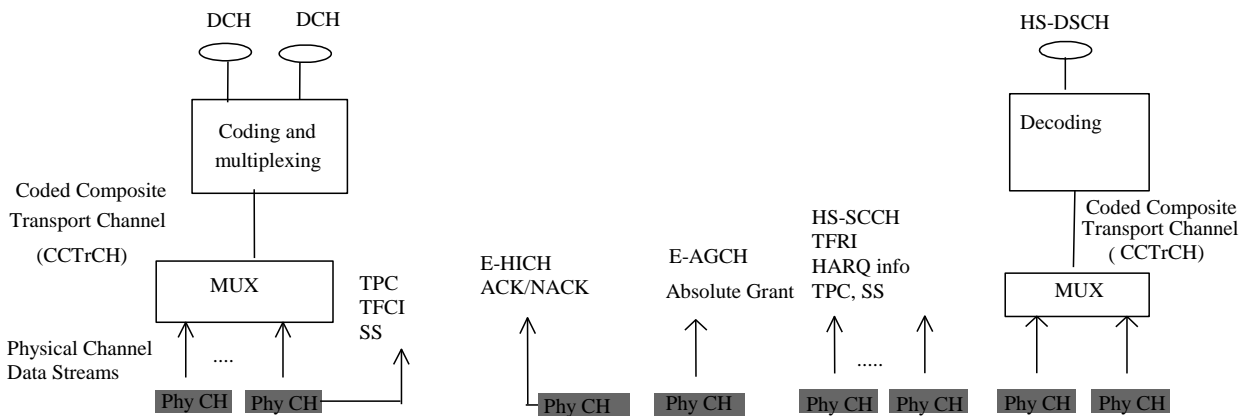

Figure 6.3.1-2: Model of the UE's Downlink physical layer

The ACK/NACKs received from UTRAN are all sent to MAC by L1.

The UE may monitor a set of E-AGCH channels in every frame (E-AGCH1, E-AGCH2, ..., E-AGCHmax). It receives an Absolute Grant if it decodes its E-RNTI on one of these E-AGCHs.

E-DCHACK/NACKs are transmitted on a physical channel called the E-HICH.

## 7 MAC architecture

### 7.1 General Principle

#### 7.1.1 MAC multiplexing

The E-DCH MAC multiplexing has the following characteristics:

- Logical channel multiplexing is supported at MAC-e level;
- Multiple MAC-d flows can be configured for one UE;
- The multiplexing of different MAC-d flows within the same MAC-e PDU is supported.
- There can be up to 8 MAC-d flows for a UE.
- Up to 16 logical channels can be multiplexed on an E-DCH transport channel

#### 7.1.2 Reordering entity

The re-ordering entity is part of a separate MAC sub-layer, MAC-es, in the SRNC. Data coming from different MAC-d flows are reordered in different reordering queues. There is one reordering queue per logical channel. The reordering is based on a specific TSN included in the MAC-es PDU. For each MAC-es PDU, the SRNC receives the TSN originating from the UE to perform the re-ordering. Additional mechanisms (e.g. timer-based and/or window-based) are up to SRNC implementation and will not be standardised. Furthermore, the reordering entity detects and removes duplicated received MAC-es PDUs.

## 7.2 MAC architecture – UE side

### 7.2.1 Overall architecture

The overall UE MAC architecture, which is shown in Figure 7.2.1-1, includes a new MAC-es/MAC-e entity which controls access to the E-DCH. A new connection from MAC-d to MAC-es/MAC-e is added to the architecture, as well as a connection between MAC-es/MAC-e and the MAC Control SAP.

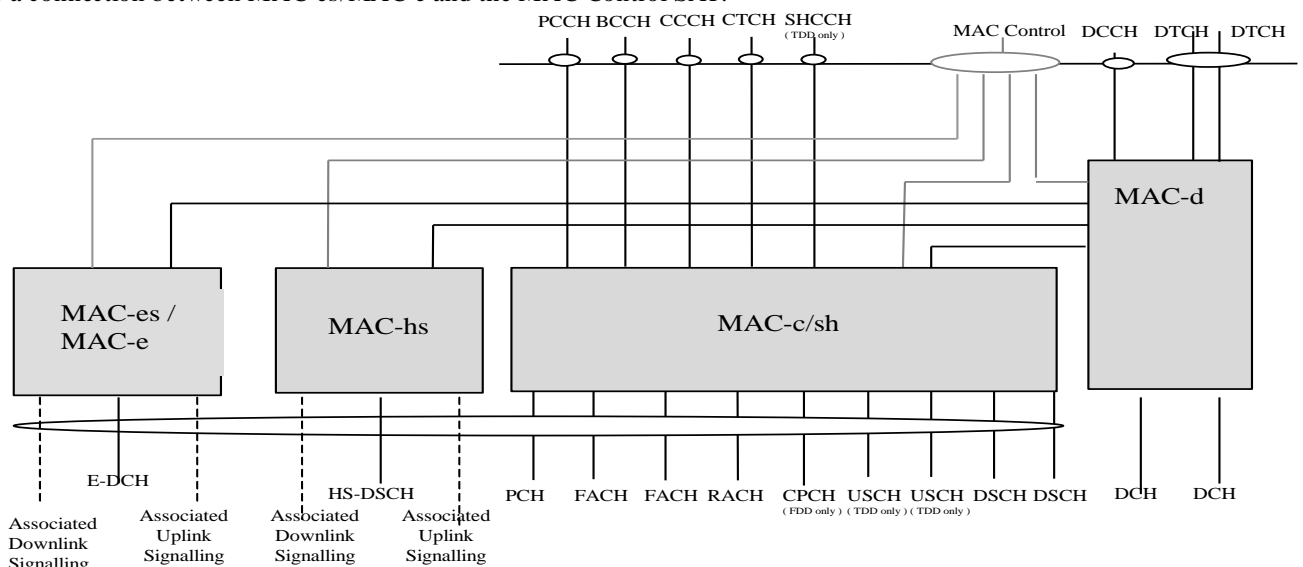
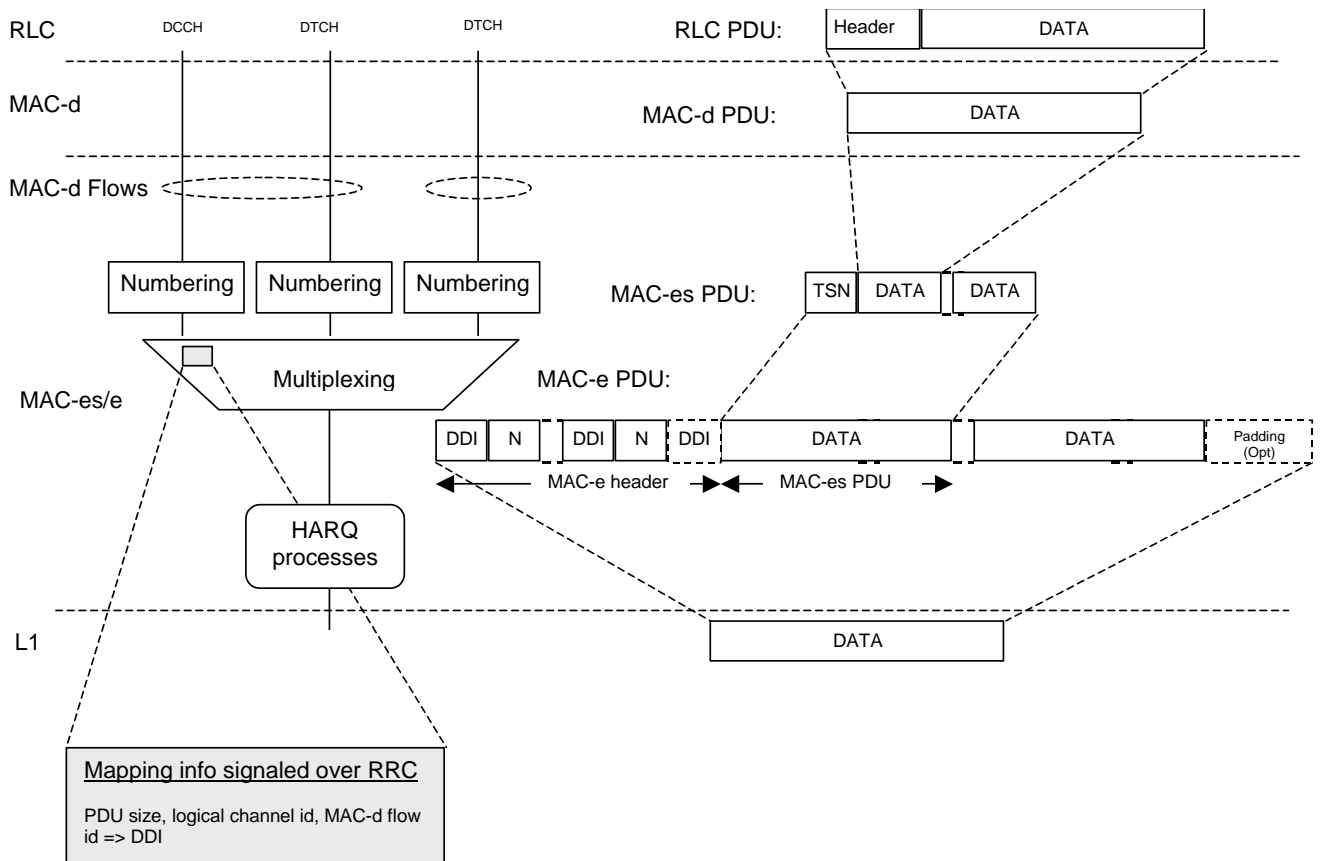

Figure 7.2.1-1: UE side MAC architecture

As shown in Figure 7.2.1-2, a RLC PDU enters MAC-d on a logical channel. The MAC-d C/T multiplexing is bypassed. In the MAC-e header, the DDI (Data Description Indicator) field (6 bits) identifies the logical channel, MAC-d flow and MAC-d PDU size. A mapping table is signalled over RRC, to allow the UE to set DDI values. The N field (fixed size of 6 bits) indicates the number of consecutive MAC-d PDUs corresponding to the same DDI value. A special value of the DDI field indicates that no more data is contained in the remaining part of the MAC-e PDU. The TSN field (6 bits) provides the transmission sequence number for each MAC-e PDU. The MAC-e PDU is forwarded to a Hybrid ARQ entity, which then forwards the MAC-e PDU to layer 1 for transmission in one TTI.



**Figure 7.2.1-2: Simplified architecture showing MAC inter-working in UE. The left part shows the functional split while the right part shows PDU construction.**

### 7.2.2 Details of MAC-d

For support of E-DCH a new connection to MAC-e/es is added.

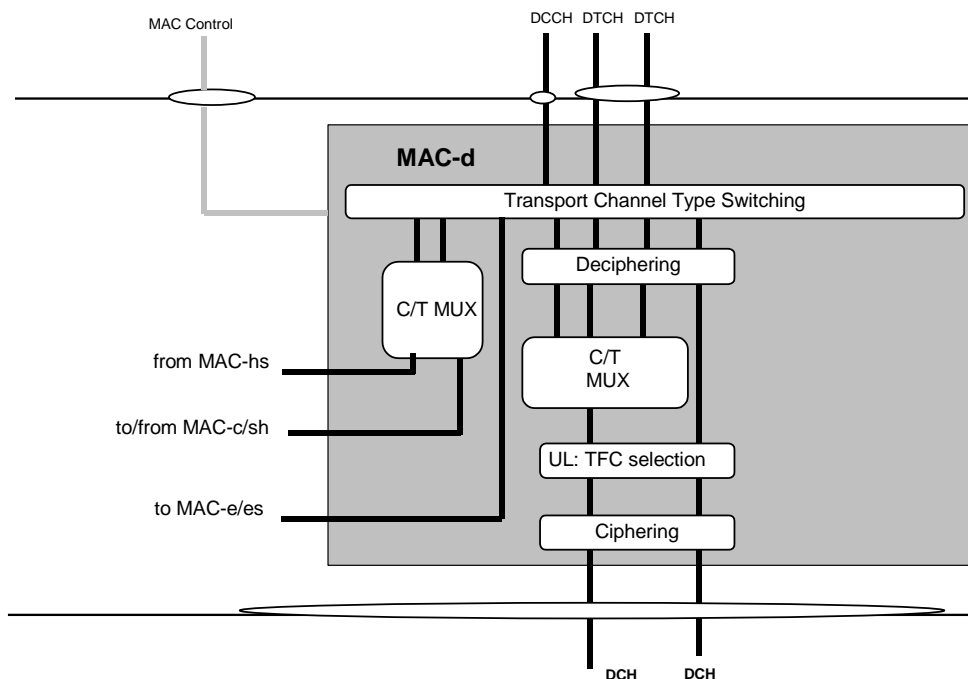

Figure 7.2.2-1: UE side MAC architecture/ MAC-d details

### 7.2.3 Details of MAC-c/sh

The support of E-DCH implies no change to the UE MAC-c/sh entity.

### 7.2.4 Details of MAC-hs

The support of E-DCH implies no change to the UE MAC-hs entity.

### 7.2.5 Details of MAC-es/MAC-e

The MAC-es/e handles the E-DCH specific functions. The split between MAC-e and MAC-es in the UE is not detailed. In the model below the MAC-e/es comprises the following entities:

- HARQ:
 

The HARQ entity is responsible for handling the MAC functions relating to the HARQ protocol. It is responsible for storing MAC-e payloads and re-transmitting them. The detailed configuration of the hybrid ARQ protocol is provided by RRC over the MAC-Control SAP. The HARQ entity provides the HARQ process identity, the E-TFC, the retransmission sequence number (RSN) and an indication of the power to be used by L1. The redundancy version (RV) of the HARQ transmission is derived by L1 from RSN. RRC signalling can also configure the HARQ entity to use RV=0 for every transmission.
- Multiplexing:
 

The multiplexing entity is responsible for concatenating multiple MAC-d PDUs into MAC-es PDUs, and to multiplex one or multiple MAC-es PDUs into a single MAC-e PDU, to be transmitted at the next TTI, and as instructed by the E-TFC selection function. It is also responsible for managing and setting the TSN per logical channel for each MAC-es PDU.
- E-TFC selection:
 

This entity is responsible for E-TFC selection according to the scheduling information (Absolute Grants) received from UTRAN via L1, and for arbitration among the different flows mapped on the E-DCH. The detailed configuration of the E-TFC entity is provided by RRC over the MAC-Control SAP. The E-TFC selection function controls the multiplexing function.
- Scheduling Access Control:

The Scheduling Access Control entity is responsible for routing associated uplink signalling (scheduling information) via MAC-e PDU (in the case that E-DCH resources are assigned) or via E-RUCCH (in the case that

no E-DCH resources are assigned). It is also responsible for obtaining and formatting the appropriate information to be carried on MAC-e PDU/E-RUCCH. Other signalling parameters such as HARQ process ID and E-TFCI will be carried on E-UCCH.

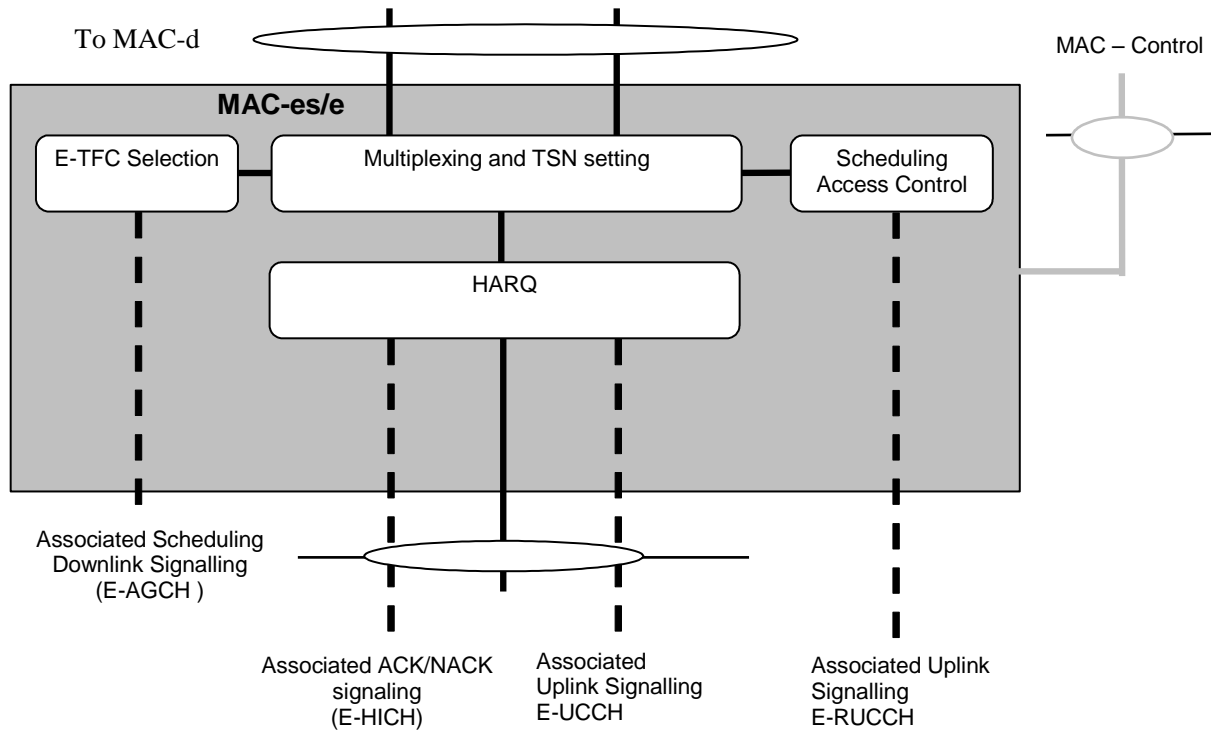
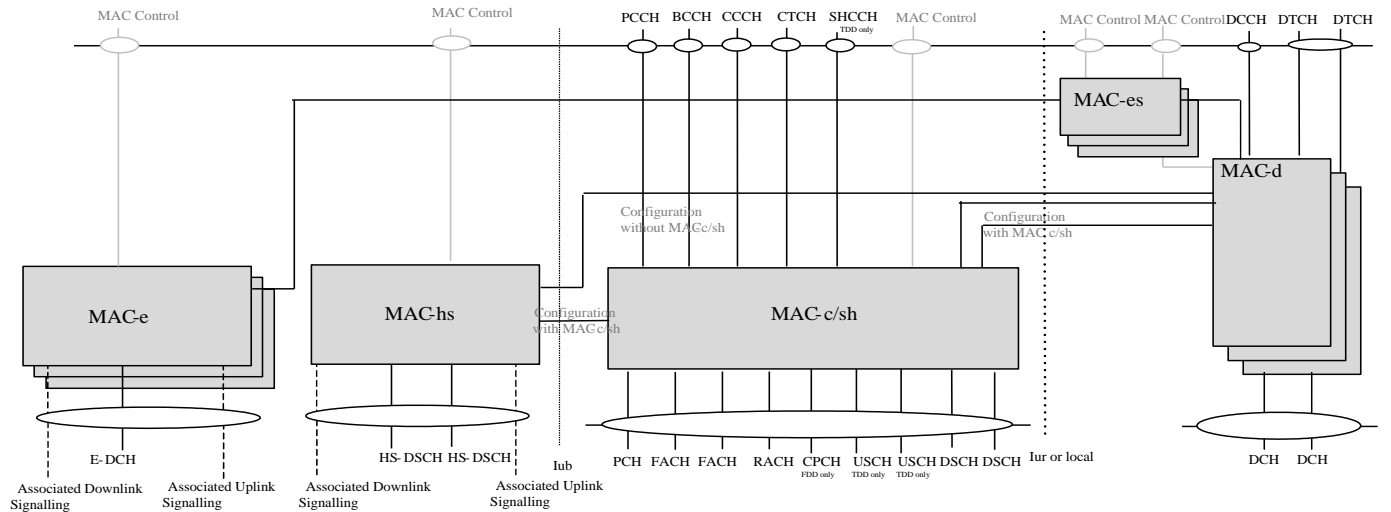

Figure 7.2.5-1: UE side MAC architecture / MAC-es/e details

### 7.3 MAC architecture – UTRAN side

#### 7.3.1 Overall architecture

The overall UTRAN MAC architecture, which is shown in Figure 7.3.1-1, includes a new MAC-e entity and a new MAC-es entity. For each UE that uses E-DCH, one MAC-e entity per Node-B and one MAC-es entity in the SRNC are configured. MAC-e, located in the Node B, controls access to the E-DCH and is connected to MAC-es, located in the SRNC. MAC-es is further connected to MAC-d. For control information, new connections are defined between MAC-e and a MAC Control SAP in the Node B, and between MAC-es and the MAC Control SAP in the SRNC. There is one Iub transport bearer per MAC-d flow (i.e. MAC-es PDUs carrying MAC-d PDUs from the same MAC-d flow).



**Figure 7.3.1-1: UTRAN side MAC architecture**

As shown in Figure 7.3.1-2, a MAC-e PDU enters MAC from layer 1. After Hybrid ARQ handling, the MAC-e PDU is demultiplexed to form MAC-es PDUs aimed for one or more MAC-d flows. The mapping between the DDI (Data Description Indicator) fields (6 bits) and the MAC-d flow and MAC-d PDU size is provided to the Node B by the SRNC. The mapping of the MAC-d flow into its Iub bearer is defined by the SRNC. A special value of the DDI field indicates that no more data is contained in the remaining part of the MAC-e PDU. The MAC-es PDUs are sent over Iub to MAC-es, where they are distributed on the reordering queue of each logical channel. After re-ordering, the in-sequence data units are disassembled. The resulting MAC-d PDUs are forwarded to MAC-d and RLC.

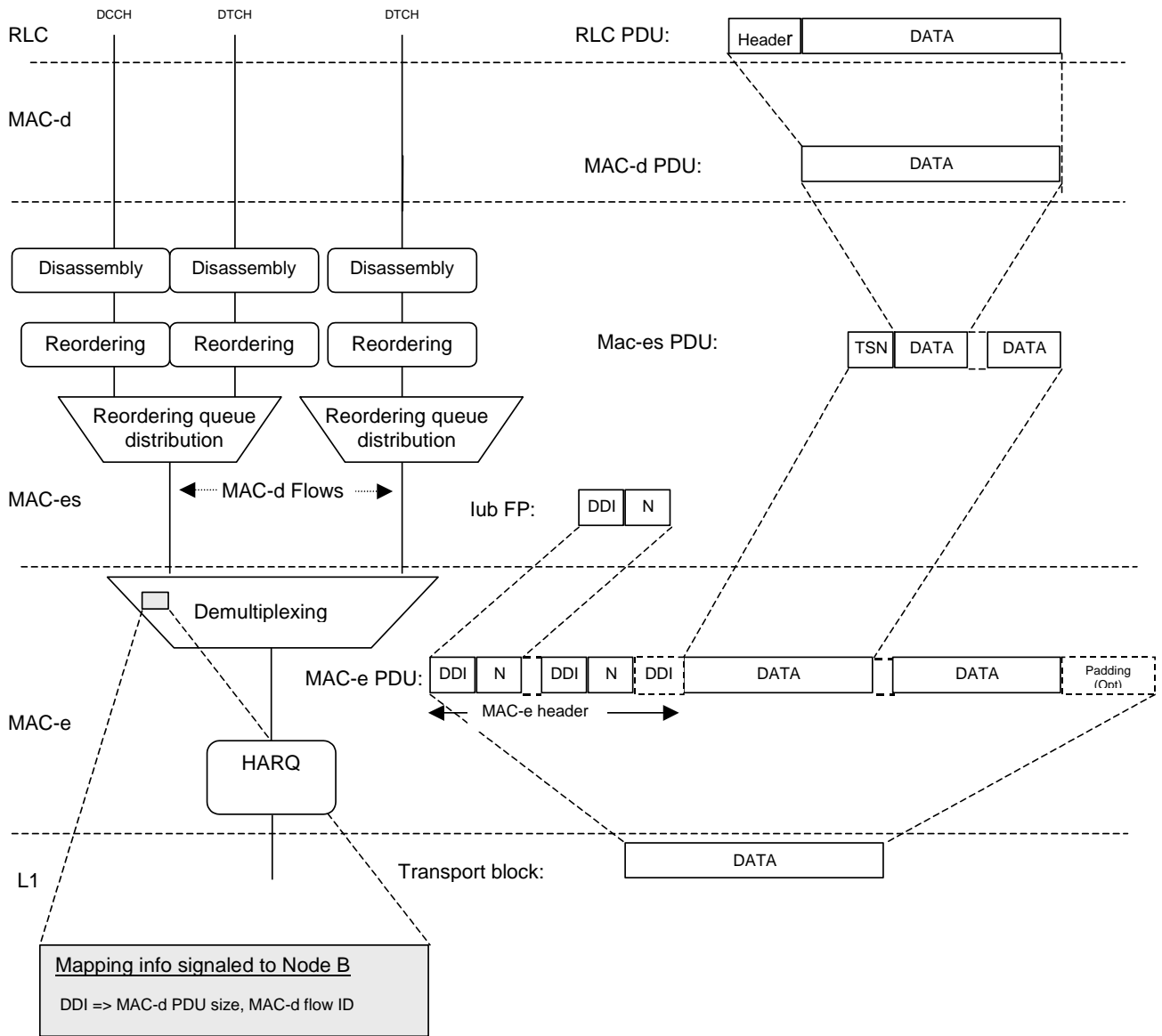

**Figure 7.3.1-2: Simplified architecture showing MAC inter-working in UTRAN. The left part shows the functional split while the right part shows PDU decomposition.**

### 7.3.2 Details of MAC-d

For support of E-DCH a new connection to MAC-es is added.

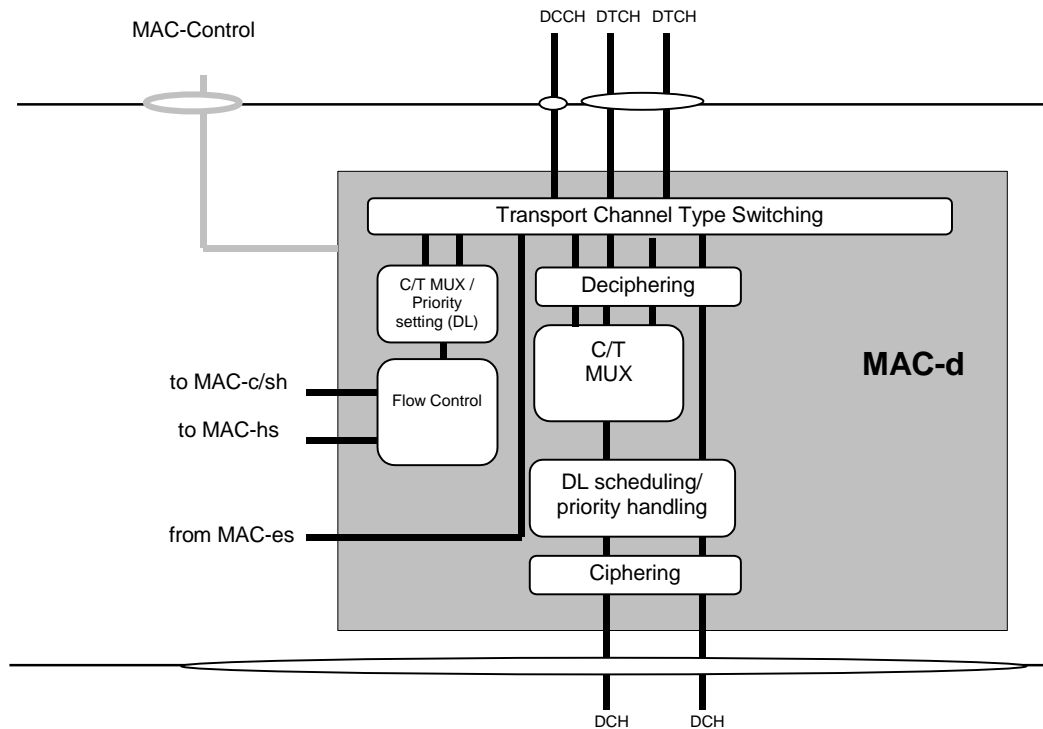

Figure 7.3.2-1: UTRAN side MAC architecture / MAC-d details

### 7.3.3 Details of MAC-c/sh

The support of E-DCH implies no change to the UTRAN MAC-c/sh entity

### 7.3.4 Details of MAC-hs

The support of E-DCH implies no change to the UTRAN MAC-hs entity.

### 7.3.5 Details of MAC-es

For each UE, there is one MAC-es entity in the SRNC. The MAC-es sublayer handles E-DCH specific functionality, which is not covered in the MAC-e entity in Node B. In the model below, the MAC-es comprises of the following entities:

- Reordering Queue Distribution:  
The reordering queue distribution function routes the MAC-es PDUs to the correct reordering buffer based the SRNC configuration.
- Reordering:  
This function reorders received MAC-es PDUs according to the received TSN. MAC-es PDUs with consecutive TSNs are delivered to the disassembly function upon reception. PDUs are not delivered to the disassembly function if PDUs with a lower TSN are missing. The number of reordering entities is controlled by the SRNC. There is one Reordering Queue per logical channel.
- Disassembly:  
The disassembly function is responsible for disassembly of MAC-es PDUs. When a MAC-es PDU is disassembled, the MAC-es header is removed, the MAC-d PDU's are extracted and delivered to MAC-d.



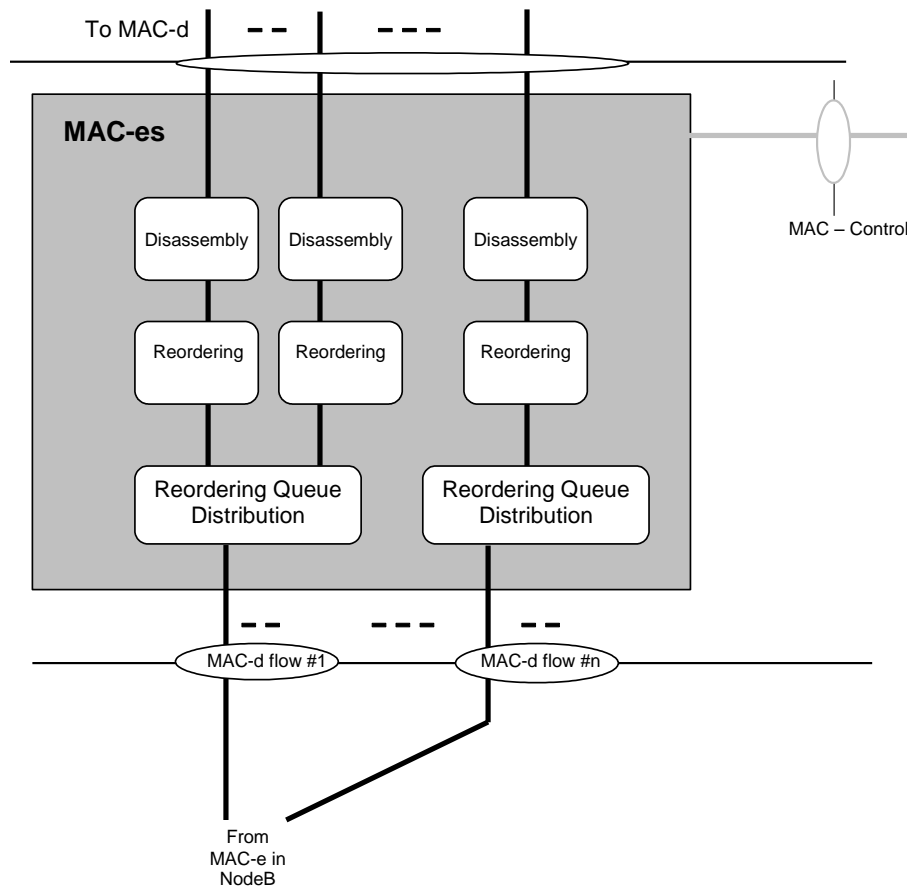

Figure 7.3.5-1: UTRAN side MAC architecture / MAC-es details

### 7.3.6 Details of MAC-e

There is one MAC-e entity in Node B for each UE and one E-DCH scheduler function in the Node-B. The MAC-e and E-DCH scheduler handle Enhanced Uplink specific functions in Node B. In the model below, the MAC-e and E-DCH scheduler comprises the following entities:

- E-DCH Scheduling :  
This function manages E-DCH cell resources between UEs. Based on scheduling requests, scheduling assignments are determined and transmitted. The general principles of the E-DCH scheduling are described in subclause 9.1 below. However implementation is not specified (i.e. depends on RRM strategy).
- E-DCH Control :  
The E-DCH control entity is responsible for reception of scheduling requests and transmission of scheduling assignments. The general principles of the E-DCH scheduling are described in subclause 9.1 below.
- De-multiplexing:  
This function provides de-multiplexing of MAC-e PDUs. MAC-es PDUs are forwarded to the associated MAC-d flow.
- HARQ:  
One HARQ entity is capable of supporting multiple instances of the stop and wait HARQ protocol. Each instance is termed a H-ARQ process and is responsible for generating ACKs or NACKs indicating delivery status of a single MAC-e PDU . The HARQ entity handles all tasks that are required for the HARQ protocol.

The associated signalling shown in the figure illustrates the exchange of information between layer 1 and layer 2 provided by primitives.

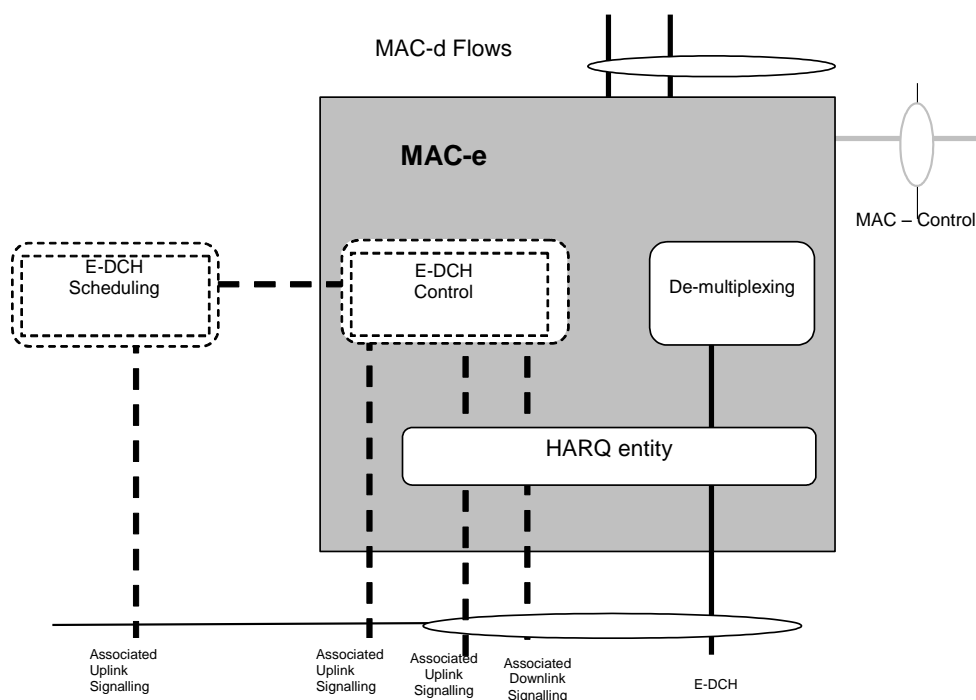

Figure 7.3.6-1: UTRAN side MAC architecture / MAC-e details

## 8 HARQ protocol

### 8.1 General Principle

The HARQ protocol has the following characteristics:

- Stop and wait HARQ is used;
- The HARQ is based on synchronous downlink ACK/NACKs;
- The HARQ is based on asynchronous retransmissions in the uplink;
- There are 8 processes (4 for scheduled transmissions and 4 for non-scheduled transmissions);
- If an Absolute Grant is received in Subframe (i) then the UE transmits a data block in Subframe (i+T1)
- For a data block transmitted in Subframe (i+T1) the UE receives an ACK/NACK in Subframe (i+T1+T2), E-HICH is decoded on the basis of slots and channelisation codes assigned via the Grant [5].
- If NACK is received in Subframe (i+T1+T2) then the UE cannot retransmit any data block previously transmitted in Subframe (i+T1) (now stored for potential retransmission) until it receives an Absolute Grant.
- The interval T3 between reception of NACK and reception of a Grant for a subsequent retransmission is variable and depends on a Node B scheduling decision.
- If an ACK is received in Subframe (i+T1+T2) then the data block previously transmitted in Subframe (i+T1) (stored for potential retransmission) is discarded and the HARQ process identity associated with the previously transmitted data block can now be reassigned.
- The number of HARQ processes is a function of T1 and T2

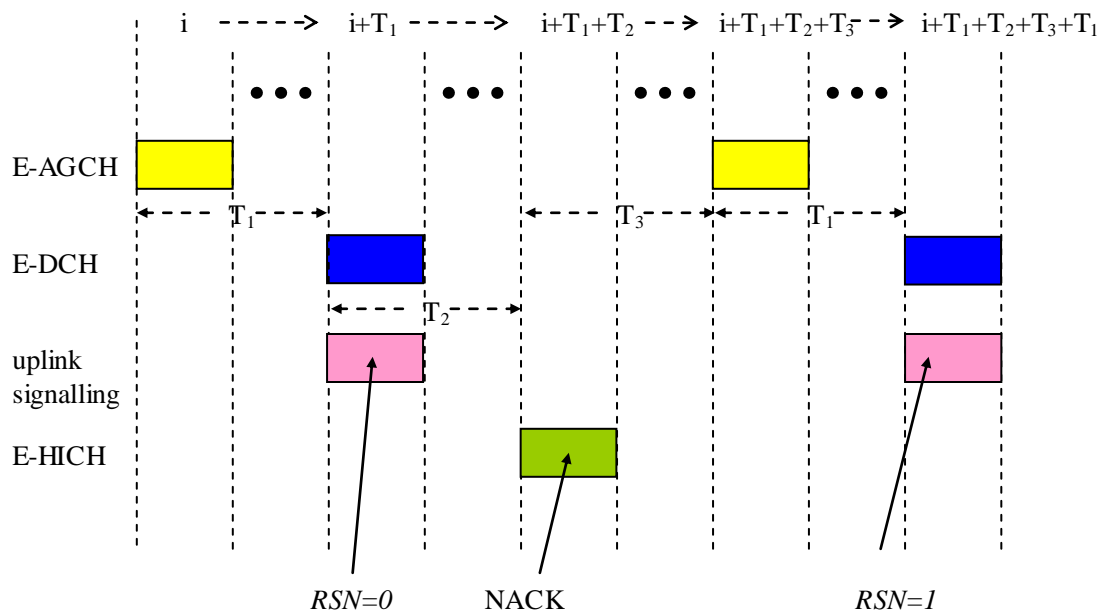

**Figure 8.1.1: TDD E-DCH HARQ**

- There will be an upper limit to the number of retransmissions. The UE decides on a maximum number of transmissions for a MAC-e PDU based on the maximum number of transmissions attribute (see subclause 11.1.1) according to the following principles:
  - The UE selects the highest maximum number of transmissions among all the considered HARQ profiles associated to the MAC-d flows in the MAC-e PDU;
  - Further optimisations such as explicit rules set by the SRNC are FFS.
- There will be an upper limit to the retransmissions time. The UE decides on maximum retransmission time for a MAC-e PDU based on the retransmission timer attribute (see subclause 11.1.1) according to the following principles:
  - The UE selects the biggest timer value among all the considered HARQ profiles associated to the MAC-d flows in the MAC-e PDU;
  - The UE shall start the timer when an NACK is indicated in E-HICH for a new PDU and give up retransmission when the timer expires.
- Incremental redundancy shall be supported by the specifications with Chase combining a subcase:
  - The first transmission shall be self decodable
  - The UTRAN configures the UE to either use the same incremental redundancy version (RV) for all transmissions, or to set the RV according to the set of rules based on E-TFC, Retransmission Sequence Number (RSN) and the transmission timing;

## 8.2 Error handling

The most frequent error cases to be handled are the following:

- NACK is detected as an ACK: The previously transmitted data block is discarded (retransmission is left up to higher layers). When the next Grant is received, the UE starts afresh by transmitting new data (it may reuse the HARQ process Id.) or by retransmitting data associated with some other HARQ process Id.;
- ACK is detected as a NACK: The UE cannot retransmit a data block until an Absolute Grant is received;

## 8.3 Signalling

### 8.3.1 Uplink

HARQ Process Identifier and Retransmission Sequence Number (RSN) are signalled on the E-UCCH.

### 8.3.2 Downlink

In the downlink, a report is used to indicate either ACK (positive acknowledgement) or NACK (negative acknowledgement).

## 9 Node B controlled scheduling

### 9.1 General Principle

The Node B controlled scheduling is based on uplink and downlink control together with a set of rules on how the UE shall behave with respect to this signaling.

In the downlink, a resource indication (Scheduling Grant) is required to indicate to the UE the maximum amount of uplink resources it may use. When issuing Scheduling Grants, the Node B may use QoS-related information provided by the SRNC and from the UE in Scheduling Requests (see subclause 9.3.1)

The Scheduling Grants have the following characteristics:

- Scheduling Grants do not influence the TFC selection for other transport channels;
- Scheduling Grants control the maximum allowed rate to be used in E-TFC selection according to information received in the Absolute Grant;
- Scheduling Grants can be sent once per TTI or slower;
- There is only one type of grant:
  - The Absolute Grant provides an absolute limitation of the maximum amount of UL resources the UE may use;
- Absolute Grants are sent by the Serving E-DCH cell:
  - They are valid for one UE
  - The UE identity to be used in the Serving E-DCH cell, the E-RNTI, is signalled to the UE via RRC
  - The UE monitors a set of E-AGCHs and decodes an Absolute Grant intended for it using the assigned E-RNTI
- The Absolute Grant contains:
  - the physical resources to be used for transmission
    - o the grant value – maximum transmit power per resource unit (per slot)
    - o Timeslots
    - o channelisation code
    - o resource duration
  - E-HICH Indicator(EI), which is used to inform UE which E-HICH the feedback info is carried on
  - E-UCCH Number Indicator(ENI), which is used to indicate the detailed number of E-UCCH

- One identity (E-RNTI) is allocated to a UE at a time. The allocation is performed by the Node-B and is sent to the UE by the SRNC, carried via RRC.
- The identity consists of 16 bits (16 bits CRC at layer 1);
- An Absolute Grant is sent via one of a set of E-AGCHs
  - For each subframe, a UE is required to monitor a set of E-AGCHs
  - An Absolute Grant is received by the UE if it decodes it using the E-RNTI that it has been allocated
  - Details of the set of E-AGCHs to be monitored are signalled to the UE via RRC

## 9.2 UE scheduling operation

### 9.2.1 Grants from the Serving Cell

The UE shall be able to receive Absolute Grant from the Serving E-DCH cell and shall select the maximum allowed rate in E-TFC selection according to information received in the Absolute Grant.

When the UE receives an Absolute Grant:

- **if** there are MAC-e PDUs awaiting retransmission and the resources assigned by the Grant enable transmission of a MAC-e PDU awaiting retransmission **then** it is used for a retransmission (oldest first) **else** it is used for a new transmission.

## 9.3 Signalling

### 9.3.1 Uplink

For the UE to request resources from the Node B, Scheduling Requests will be transmitted in the uplink in the form of Scheduling Information. The Scheduling information will be transmitted with respect to the logical channels which RRC has configured to be mapped to E-DCH.

#### 9.3.1.1 Information Required for Scheduling

##### 9.3.1.1.1 Content

The UE provides the following information for scheduling:

- Buffer Information:
  - Logical channel ID of the highest priority channel with data in buffer (4 bits). The logical channel ID field identifies unambiguously the highest priority logical channel with available data;
  - UE buffer occupancy (in Bytes):
    - Buffer status for the highest priority logical channel with data in buffer (4 bits), as a fraction of the total reported buffer;
    - Total buffer occupancy (5 bits);
- Physical Layer Information:
  - Path Loss:
    - Information derived from measurements of serving cell and neighbour cells' RSCP
  - transmit power

##### 9.3.1.1.2 Triggers

In the case where the UE has no Grant and it has data to send:

- Buffer Information and Physical Layer Information plus the E-RNTI shall be sent to the Node B on the E-RUCCH (E-DCH Random access Uplink Control Channel).

In the case where the UE has a Grant and has data to send:

- It shall send Buffer Information and Physical Layer Information to the Node B in the MAC-e PDU.

In the case where UE transits from having a Grant to not having a Grant and has data to send, a timer T\_WAIT is provided as a delay time to send buffer information mapped on E-RUCCH (T\_WAIT is configured by RRC, in Radio Bearer Setup Request, default value is 8TTI):

- When UE has sent data on E-PUCH in the last TTI before the current Grant expires:
  - The timer T\_WAIT shall be started.
- When a grant is received before the timer expires:
  - The timer shall be stopped.
- When the timer T\_WAIT expires:
  - A new E-RUCCH transmission shall be made (the timer T\_WAIT shall be stopped).

### 9.3.1.1.3 Transmission and Reliability scheme

Two transmission mechanisms are defined:

1. When Buffer Information is included in the MAC-e PDU, it is always sent with data and therefore resources are assigned for data transmission/retransmission by the Node B scheduler. HARQ retransmissions are performed until an ACK is received or until the maximum number of transmissions is reached.
2. Buffer Information plus Physical Layer Information sent via the E-RUCCH (no Scheduling Grant) is transmitted at appropriate power and forward error correction, as defined by physical layer specifications. If no response in the form of an Absolute Grant is received then the UE is required to resend Buffering Information and Physical Layer Information. For 1.28Mcps TDD, a timer T\_RUCCH and a maximum number of transmissions N\_RUCCH are used to control the retransmission of scheduling information in this case. The timer is a mechanism to serve the fact that the UE does not know about the successful reception of buffer information following an E-RUCCH transmission. The maximum number of transmissions N\_RUCCH is a mechanism to prevent the redundant transmission. T\_RUCCH and N\_RUCCH will be configured by higher layer and act as follows.
  - When the aggregate buffer volume transitions from zero to greater than zero or when the timer T\_WAIT expires:
    - the UE sends information mapped on E-RUCCH;
    - the timer T\_RUCCH shall be started and a counter is set to 1.
  - When a grant is received:
    - the timer T\_RUCCH shall be stopped and not be restarted, the counter shall be reset.
  - When the timer T\_RUCCH expires:
    - if the counter is not greater than N\_RUCCH
      - a new E-RUCCH transmission shall be made (restart the timer and increment the counter).
    - else
      - the timer T\_RUCCH shall be stopped and not be restarted, the counter shall be reset.

## 9.3.2 Downlink

For each allocated UE, there is at-most one Absolute Grant transmitted by the serving E-DCH cell per TTI using the E-AGCH.

---

# 10 Non-scheduled transmissions

When non-scheduled transmission is configured by the SRNC, the UE is allowed to send E-DCH data at any time, up to a configured resource, without receiving any scheduling command from the Node B. Thus, signalling overhead and scheduling delay are minimized.

Typical examples of data that may use non-scheduled transmission are the SRBs and GBR services.

Non-scheduled transmissions have the following characteristics:

- Non-scheduled transmissions are defined per MAC-d flow;
- The resource for non-scheduled transmission is given by the SRNC and is called non-scheduled grant; A non-scheduled grant is defined by
  - The codes and timeslots available for transmission in TTIs designated for unscheduled use
  - The frames designated for unscheduled use (specified by means of start frame number, repetition period and repetition length)
- Scheduled logical channels cannot use the non-scheduled grant.
- Multiple non-scheduled MAC-d flows may be configured in parallel by the SRNC, provided they are defined (via RRC) to use the same resources;
  - The UE is then allowed to transmit non-scheduled transmissions up to the sum of the non-scheduled grant if multiplexed in the same TTI;
- The non-scheduled transmission has separate HARQ processes from the scheduled transmission. HARQ process identifiers 0 – 3 are reserved for scheduled transmissions and HARQ process identifiers 4 – 7 are reserved for non-scheduled transmissions.
- Logical channels mapped on a non-scheduled MAC-d flow cannot transmit data using a Scheduling Grant;
- Logical channels mapped on a non-scheduled MAC-d flow can only transmit up to the non-scheduled grant configured for that MAC-d flow;
- The multiplexing list restricting the set of HARQ profiles that can be used by a given logical channel will apply both for scheduled and non-scheduled logical channels;
- Logical channels will be served in the order of their priorities until the non-scheduled grant and scheduled grants are exhausted, or the maximum transmit power is reached;
  - When multiple logical channels are assigned the highest priority, the HARQ profile corresponding to the logical channel with the highest buffer occupancy shall be selected.

Note: The above non-scheduled transmission and scheduled transmission are mutual exclusive in the same TTI. The multiplexing of non-scheduled transmission and scheduled transmission in MAC layer and combination of non-scheduled grant and scheduled grant in physical layer can improve the spectrum efficiency and throughput performance and that could be considered as a candidate scheme in later enhanced W1.

---

## 11 QoS control

### 11.1 General Principle

The QoS of ongoing flows mapped on E-DCH for a UE is maintained by the serving Node B and by the UE. The Node B controls the resources allocated to a UE versus other UEs by means of scheduling as specified in clause 9. The UE controls the QoS of all its logical channels mapped on E-DCH by means of E-TFC selection as specified in subclause 11.2, and by HARQ operation, specified in clause 8.

In addition to these mechanisms, guaranteed bit rate services for MAC-d flows are also supported through non-scheduled transmission. A flow using non-scheduled transmission is defined by the SRNC and provided in the UE and in the Node B. Details on non-scheduled transmission can be found in section 10.

#### 11.1.1 QoS configuration principles

RAB attributes are available in the SRNC according to R'99 principles. To enable QoS control for the E-DCH, QoS-related information is made available in the UE and in the Node B as outlined below.

To the UE, the following QoS-related information is provided from the SRNC to enable QoS-based E-TFC selection, multiplexing of logical channels in MAC-e PDUs, and HARQ operation:

- Logical channel priority for each logical channel (as in Rel-5);
- Mapping between logical channel(s) and MAC-d flow(s) (as in Rel-5);
- Allowed MAC-d flow combinations in one MAC-e PDU;
- Power offset for reference E-TFC(s). The UE then calculates the power offsets for its other E-TFCs so that the quality (protection of a MAC-e PDU) when using any of the E-TFCs is identical to that of the reference E-TFC(s);
- HARQ profile per MAC-d flow. One HARQ profile consists of a power offset attribute and, a maximum number of transmissions attribute and retransmission timer attribute. The power offset attribute is used in E-TFC selection to regulate the BLER operating point for the transmission. The maximum number of transmissions attribute and the retransmission timer attribute are used in the HARQ operation to regulate maximal latency and residual BLER of MAC-d flows.
- The non-scheduled grant (only for MAC-d flows that are configured for non-scheduled transmission).

To the Node B, the following QoS-related parameters are provided by the SRNC to enable scheduling and resource reservation:

- Power offsets for reference E-TFC(s). The Node B then calculates the power offsets for the other E-TFCs. This information is used whenever the nodeB needs to convert between rate and power in its resource allocation operation;
- E-UCCH FEC protection level for non-scheduled transmission;
- HARQ profile per MAC-d flow. One HARQ profile consists of a power offset attribute, a maximum number of transmissions attribute and retransmission timer attribute. The power offset attribute is used whenever the Node B needs to convert between rate and power in its resource allocation operation;
- Guaranteed bit rate for logical channels that carry guaranteed bit rate services. It is used to allocate grants to UEs;
- The non-scheduled grant for MAC-d flows that are configured for non-scheduled transmission. It is used for the Node B to determine those resources assigned to non-scheduled operation and those resources assigned to scheduled operation and to reserve a sufficient amount of resources.
- Maximum UL UE power, as a minimum of the UE maximum transmit power (as per UE power class) and maximum allowed UL Tx power configured by UTRAN.
- Scheduling priority per logical channel of logical channels mapped to E-DCH and the corresponding mapping between logical channel identifier and DDI value. This information enables Node B to consider QoS related information of the logical channels for efficient scheduling.

## 11.2 TFC and E-TFC selection

The principle of the TFC selection across E-DCH and DCH is the following :

- If DCH is configured:
  - The UE performs TFC restriction for the CCTrCH of DCH type;
  - The UE performs the TFC selection for the DCHs;
  - E-TFC restriction is performed with the following characteristics;
    - The E-TFC restriction mechanism is independent of the existing TFC restriction;
    - The E-TFC states defined per MAC-d flow are managed independently of the TFC states;
    - A maximum of 1 E-PUCH may be transmitted by a UE within a timeslot;
    - The result of E-TFC restriction is a state (blocked or supported) per E-TFC and MAC-d flow;
    - The minimum set of E-TFCs is defined as the number of bits that can be transmitted on RRC-assigned (i.e.



non-scheduled) resources in a TTI independent of the power situation in the UE. The E-TFCs belonging to the minimum set are in supported state;

- The UE performs the E-TFC selection for the E-DCH, taking into account the following rules:
  - The E-TFC selection is based on logical channel priorities like in the Release '99, i.e. the UE shall maximise the transmission of higher priority data;
  - The UE shall respect the allowed combinations of MAC-d flows in the same MAC-e PDU;
  - The UE shall use the multiplexing list of the different MAC-d flows to see if a certain MAC-d flow can use the power offset of the highest priority MAC-d flow to be transmitted;
  - The supported/blocked E-TFCs for a MAC-e PDU including MAC-d PDUs coming from one or several MAC-d flows are obtained as follows:
    - The UE uses the E-TFC restriction result (i.e. blocked/supported E-TFCs) associated to the MAC-d flow with the highest priority logical channel in the MAC-e PDU;
    - Among the supported E-TFCs, the UE selects the smallest E-TFC that maximises the transmission of data according to the non-scheduled grant(s) and the serving grant;
- For each transmission, the MAC-e entity gives the selected power offset of E-PUCH(s) relative to the base power  $P_{e-base}$  to the L1 in addition to the E-TFC;
- In the case that the selected E-TFC leads to a case where the maximum UE transmit power is exceeded because the selected E-TFC is part of the minimum set, the UE shall power scale down all physical channels present.

### 11.3 Setting of Power offset attributes of MAC-d flows

Power offset attributes of MAC-d flows are part of the HARQ profiles of the MAC-d flow. They are provided by the UTRAN to the UE according to the following principles:

- Power control of the CCTrCH of E-DCH type is based on a combination of an open loop power control component as used in Release '99/4/5/6 and a closed loop TPC component (signalled from Node B to UE alongside the Absolute Grant).
- With each MAC-es PDU transmitted to the SRNC, the Node-B includes the number of transmissions that have been required to correctly decode the PDU;
- Using the information provided by the Node B, the SRNC may maintain up to date power offsets;
- The SRNC may decide to signal to the UE and the node B set new values for the power offset attributes for one (or several) MAC-d flows.

---

## 12 Signalling parameters

### 12.1 Uplink signalling parameters

Void.

### 12.2 Downlink signalling parameters

With RRC signalling, the UE will in addition be informed about:

- The E-RNTI assigned
- Minimum number of slots between start of last active slot of E-DCH TTI and start of ACK/NACK on E-HICH
- The set of E-HICH configuration the UE may use

- Including timeslot, channelisation code, midamble;
- The mapping between EI (E-HICH Indicator) and E-HICH physical resource
- For non-scheduled UE, the orthogonal sequences group for HARQ acknowledgement indicator and TPC/SS command transmission
- The set of E-AGCHs configured
  - Including timeslot and channelisation code, midamble for each E-AGCH
  - TPC step size
  - RDI Indicator which indicates a RDI field is present on E-AGCH
  - E-AGCH BLER target
- E-UCCH configuration for non-scheduled transmission
- E-RUCCH configuration
  - T\_WAIT
  - T\_RUCCH
  - N\_RUCCH
- The E-PUCH configuration including:
  - reference Beta values to use.
    - For each reference E-TFC a (nominal) beta factor is calculated based on the power offset signalled for each reference E-TFC via RRC (maximum number of reference E-TFCs is 8);
  - timeslots assigned to E-PUCH
  - identities of the E-PUCH timeslots which are to carry TPC and TFCI bits
  - reference Desired E-PUCH RX power
  - for each E-PUCH timeslot:
    - midamble
    - minimum code rate, maximum code rate
  - TPC step size
  - SS step size
- HARQ Incremental Redundancy Version configuration. RV=0 or a predefined RV table may be used;
- E-DCH Scheduling Information parameters:
  - Logical channels for which Scheduling Information is expected to be reported by the UE
  - Logical channel identity of logical channels mapped to E-DCH
- Non-scheduled grant;
  - Serving Grant to be used by UE
  - timeslots allocated for non-scheduled transmissions, maximum power granted per resource unit (per slot)
  - repetition periodicity in TTIs and repetition length
  - code resource information
  - reference Desired E-PUCH RX power

- SYNC\_UL used for E-DCH random access configuration
- Indicate SYNC\_ULs dedicatedly used for E-DCH random access

RRC will signal the mapping between logical channels, MAC-d PDU size, MAC-d flow ID and Data Description Indicator (see clause 7).

RRC will signal for each MAC d-flow, the MAC-d flow specific power offset, the maximum number of transmissions, and the multiplexing list (indicating with which other MAC-d flows, MAC-d PDU's of this flow can be multiplexed in the same MAC-e PDU).

---

## 13 Mobility procedures

Change of cell for E-DCH scheduling is supported via RRC signalling.

UTRAN may:

- select the serving cell which provides the best downlink quality.

UE based change of cell or mechanisms using L2 signalling are not supported for E-DCH mobility.

When an E-DCH cell change is triggered:

- The E-RNTI the UE will use is given by RRC;
- Processes can be enabled/disabled via RRC;
- For non-scheduled transmissions, the resources are signaled via RRC;
- For scheduled transmission, the resources to be used are signaled via an Absolute Grant

---

## Annex A (informative): Change history

Change history							
Date	TSG #	TSG Doc.	CR	Rev	Subject/Comment	Old	New
03-2007	RP-35	RP-070135	-		Approved at TSG-RAN #35 and placed under Change Control	2.0.0	7.0.0
06-2007	RP-36	RP-070397	0001		Some corrections for LCR TDD EUL	7.0.0	7.1.0