

3GPP TS 29.334 V11.2.0 (2013-06)

Technical Specification

**3rd Generation Partnership Project;
Technical Specification Group Core Network and Terminals;
IMS Application Level Gateway (IMS-ALG) – IMS Access
Gateway (IMS-AGW);
Iq Interface;
Stage 3
(Release 11)**



Keywords

UMTS, LTE, IP, Multimedia

3GPP

Postal address

3GPP support office address

650 Route des Lucioles - Sophia Antipolis
Valbonne - FRANCE
Tel.: +33 4 92 94 42 00 Fax: +33 4 93 65 47 16

Internet

<http://www.3gpp.org>

Copyright Notification

No part may be reproduced except as authorized by written permission.
The copyright and the foregoing restriction extend to reproduction in all media.

© 2013, 3GPP Organizational Partners (ARIB, ATIS, CCSA, ETSI, TTA, TTC).
All rights reserved.

UMTS™ is a Trade Mark of ETSI registered for the benefit of its members
3GPP™ is a Trade Mark of ETSI registered for the benefit of its Members and of the 3GPP Organizational Partners
LTE™ is a Trade Mark of ETSI registered for the benefit of its Members and of the 3GPP Organizational Partners
GSM® and the GSM logo are registered and owned by the GSM Association

Contents

Foreword	4
1 Scope	5
2 References.....	6
3 Definitions, symbols and abbreviations	8
3.1 Definitions	8
3.2 Symbols.....	8
3.3 Abbreviations.....	8
4 Applicability	9
4.1 Architecture	9
5 Profile Description	9
5.1 Profile Identification	9
5.2 Summary	9
5.3 Gateway Control Protocol Version	10
5.4 Connection model.....	10
5.5 Context attributes.....	10
5.6 Terminations.....	11
5.6.1 Termination names	11
5.6.1.1 IP Termination.....	11
5.6.1.1.1 ABNF Coding Overview and prose specification	11
5.6.1.1.2 ASN.1 Coding Overview and prose specification	11
5.6.2 Multiplexed terminations.....	12
5.7 Descriptors.....	12
5.7.1 TerminationState Descriptor	12
5.7.2 Stream Descriptor.....	13
5.7.2.0 General.....	13
5.7.2.1 LocalControl Descriptor	13
5.7.3 Events descriptor.....	13
5.7.4 EventBuffer descriptor	15
5.7.5 Signals descriptor.....	15
5.7.6 DigitMap descriptor.....	16
5.7.7 Statistics descriptor.....	16
5.7.8 ObservedEvents descriptor.....	16
5.7.9 Topology descriptor.....	16
5.7.10 Error descriptor.....	17
5.8 Command API.....	19
5.8.1 Add	19
5.8.2 Modify.....	19
5.8.3 Subtract	20
5.8.4 Move.....	20
5.8.5 AuditValue	20
5.8.6 AuditCapabilities.....	20
5.8.7 Notify	21
5.8.8 ServiceChange.....	21
5.8.9 Manipulating and auditing context attributes.....	23
5.9 Generic command syntax and encoding.....	23
5.10 Transactions.....	23
5.11 Messages.....	24
5.12 Transport.....	24
5.13 Security.....	25
5.14 Packages.....	25
5.14.1 Mandatory Packages	25
5.14.2 Optional Packages	26
5.14.3 Package usage information	27
5.14.3.1 Generic (g)	27

5.14.3.2	Base root (root).....	28
5.14.3.3	Differentiated Services (ds).....	29
5.14.3.4	Gate Management (gm)	29
5.14.3.5	Traffic management (tman).....	31
5.14.3.6	Inactivity Timer (it)	32
5.14.3.7	IP Domain Connection (ipdc).....	32
5.14.3.8	Media Gateway Overload Control Package (ocp).....	33
5.14.3.9	Hanging Termination Detection (hangterm)	33
5.14.3.10	Media Gateway Resource Congestion handling Package (chp)	34
5.14.3.11	IP Realm Availability (ipra).....	34
5.14.3.12	IP NAPT Traversal (ipnapt).....	35
5.14.3.13	RTCP Handling Package (rtcph).....	35
5.14.3.14	Application Data Inactivity Detection (adid)	36
5.14.3.15	Explicit Congestion Notification for RTP-over-UDP Support (ecnrous).....	37
5.15	Mandatory support of SDP and Annex C information elements	39
5.16	Optional support of SDP and Annex C information elements.....	41
5.17	Procedures.....	41
5.17.1	Formats and Codes.....	41
5.17.2	Call Related Procedures	45
5.17.2.1	General.....	45
5.17.2.2	Reserve AGW Connection Point.....	45
5.17.2.3	Configure AGW Connection Point.....	47
5.17.2.4	Reserve and Configure AGW Connection Point	49
5.17.2.5	Release AGW Termination	52
5.17.2.6	Termination Heartbeat Indication	52
5.17.2.7	IP Bearer Released.....	53
5.17.2.8	Media Inactivity Notification.....	53
5.17.2.9	Change Through Connection.....	54
5.17.2.10	Change Flow Direction	54
5.17.2.11	ECN Failure Indication	55
5.17.3	Non-Call Related Procedures.....	55
5.17.3.1	General.....	55
5.17.3.2	IMS-AGW Out Of Service	56
5.17.3.3	IMS-AGW Communication Up	57
5.17.3.4	IMS-AGW Restoration	57
5.17.3.5	IMS-AGW Register.....	58
5.17.3.6	IMS-AGW Re-Register	58
5.17.3.7	IMS-ALG Ordered Re-register.....	59
5.17.3.8	IMS-ALG Restoration.....	59
5.17.3.9	IMS-ALG Out of Service	60
5.17.3.10	Audit Value.....	60
5.17.3.11	Command Rejected	62
5.17.3.12	AGW Capability Change.....	62
5.17.3.13	IMS-AGW Resource Congestion Handling – Activate	62
5.17.3.14	IMS-AGW Resource Congestion Handling – Indication	63
5.17.3.15	Inactivity Timeout – Activation	63
5.17.3.16	Inactivity Timeout – Indication	64
5.17.3.17	Realm Availability Change – Activation.....	64
5.17.3.18	Realm Availability Change – Indication.....	64
5.17.3.19	Termination Out Of Service	65
Annex A (informative): Change history.....		66

Foreword

This Technical Specification has been produced by the 3rd Generation Partnership Project (3GPP).

The contents of the present document are subject to continuing work within the TSG and may change following formal TSG approval. Should the TSG modify the contents of the present document, it will be re-released by the TSG with an identifying change of release date and an increase in version number as follows:

Version x.y.z

where:

- x the first digit:
 - 1 presented to TSG for information;
 - 2 presented to TSG for approval;
 - 3 or greater indicates TSG approved document under change control.
- y the second digit is incremented for all changes of substance, i.e. technical enhancements, corrections, updates, etc.
- z the third digit is incremented when editorial only changes have been incorporated in the document.

1 Scope

The present document describes the protocol to be used on the IMS Application Level Gateway (ALG) – IMS Access Gateway (IMS-A GW) interface. The basis for this protocol is the H.248 protocol as specified in ITU-T. The IMS architecture is described in 3GPP TS 23.228 [2]. The underlying reference model and stage 2 information is described in Annex G of 3GPP TS 23.228 [2] and in 3GPP TS 23.334 [23].

This specification describes the application of H.248 on the Iq interface (see Figure 1). Required extensions use the H.248 standard extension mechanism. In addition certain aspects of the base protocol H.248 are not needed for this interface and thus excluded by this profile.

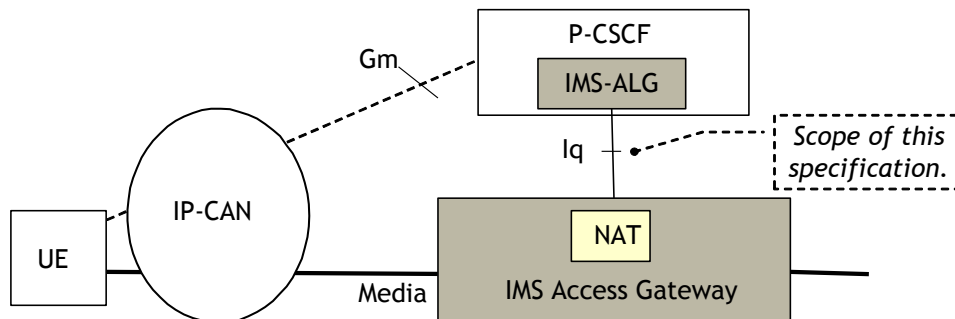

Figure 1: Reference model for IMS access

The reference model for the IMS-ALG and the IMS-A GW supporting the ATCF/ATGW function is shown in Figure 1a below.

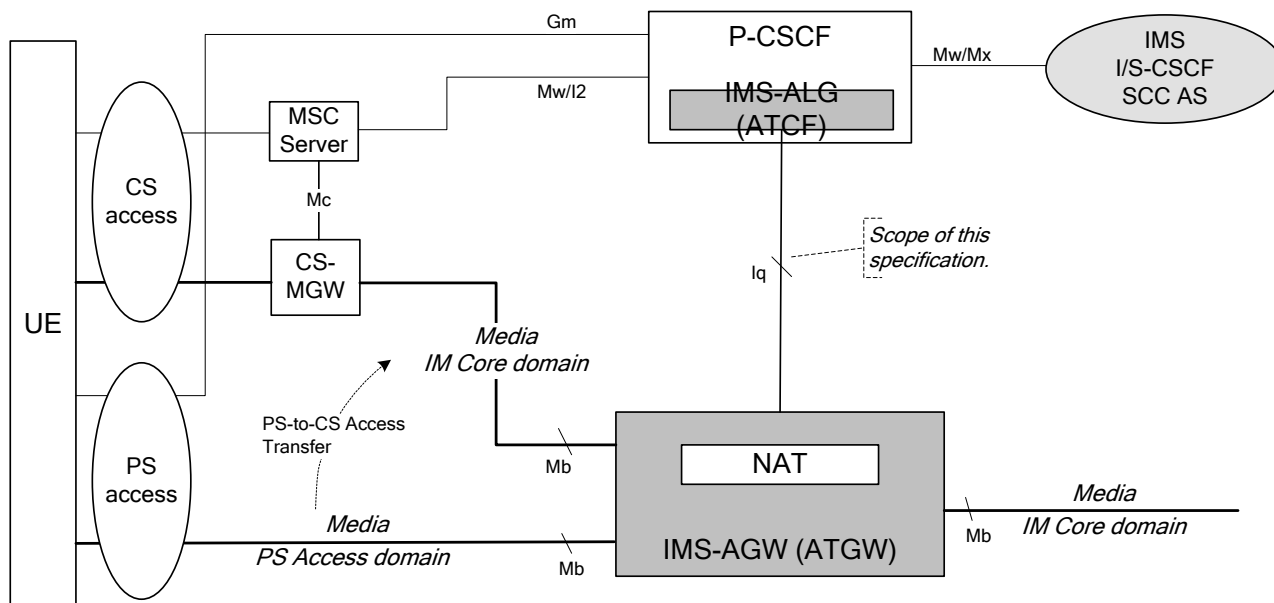

Figure 1a: Reference model for IMS-ALG/IMS-AGW with ATCF/ATGW function

See 3GPP TS 23.237 [38] subclause 5.2 for a comprehensive description of the reference model.

2 References

The following documents contain provisions which, through reference in this text, constitute provisions of the present document.

- References are either specific (identified by date of publication, edition number, version number, etc.) or non-specific.
- For a specific reference, subsequent revisions do not apply.
- For a non-specific reference, the latest version applies. In the case of a reference to a 3GPP document (including a GSM document), a non-specific reference implicitly refers to the latest version of that document *in the same Release as the present document*.

- [1] 3GPP TR 21.905: "Vocabulary for 3GPP Specifications".
- [2] 3GPP TS 23.228: "IP Multimedia Subsystem (IMS); Stage 2".
- [3] ETSI TS 183 018 V3.5.1 (2009-07): "Telecommunications and Internet converged Services and Protocols for Advanced Networking (TISPAN); Resource and Admission Control: H.248 Profile Version 3 for controlling Border Gateway Functions (BGF) in the Resource and Admission Control Subsystem (RACS); Protocol specification".
- [4] ITU-T Recommendation H.248.37 (06/2008): "Gateway control protocol: IP NAPT traversal package".
- [5] ITU-T Recommendation H.248.57 (06/2008): "Gateway control protocol: RTP Control Protocol Package".
- [6] ITU-T Recommendation H.248.43 (06/2008): "Gateway control protocol: Gate Management and Gate Control packages".
- [7] ITU-T Recommendation H.248.53 (03/2009): "Gateway control protocol: Traffic management packages".

- [8] ITU-T Recommendation H.248.41 Amendment 1 (06/2008): "Gateway control protocol: IP domain connection package: IP Realm Availability Package".
- [9] ITU-T Recommendation H.248.36 (09/2005): "Gateway control protocol: Hanging Termination Detection package".
- [10] ITU-T Recommendation H.248.1 (05/2002): "Gateway Control Protocol: Version 2" including the Corrigendum1 for Version 2 (03/04).
- [11] ITU-T Recommendation H.248.14 (03/2009): "Gateway control protocol: Inactivity timer package".
- [12] ITU-T Recommendation H.248.52 (06/2008): "Gateway control protocol: QoS support packages".
- [13] ITU-T Recommendation H.248.11 (11/2002): "Gateway control protocol: Media gateway overload control package".
Inclusive Corrigendum 1 (06/2008) to H.248.11 " Gateway control protocol: Media gateway overload control package: Clarifying MG-overload event relationship to ADD commands".
- [14] ITU-T Recommendation H.248.10 (07/2001): "Media gateway resource congestion handling package".
- [15] IETF RFC 5234 (2008): "Augmented BNF for Syntax Specifications: ABNF".
- [16] IETF RFC 4960 (2007): "Stream control transmission protocol".
- [17] IETF RFC 4566 (2006): "SDP: Session Description Protocol".
- [18] IETF RFC 4975 (2007): "The Message Session Relay Protocol (MSRP)".
- [19] IETF RFC 3551 (2003): "RTP Profile for Audio and Video Conferences with Minimal Control".
- [20] IETF RFC 4145 (2005): "TCP-Based Media Transport in the Session Description Protocol (SDP)".
- [21] IETF RFC 3605 (2003): "Real Time Control Protocol (RTCP) attribute in Session Description Protocol (SDP)".
- [22] ITU-T Recommendation X.690 (11/2008): "ASN.1 encoding rules: Specification of Basic Encoding Rules (BER), Canonical Encoding Rules (CER) and Distinguished Encoding Rules (DER)".
- [23] 3GPP TS 23.334: "IMS Application Level Gateway (IMS-ALG) – IMS Access Gateway (IMS-AGW) interface: Procedures Descriptions".
- [24] ITU-T Recommendation H.248.40 (01/2007): "Gateway control protocol: Application Data Inactivity Detection package".
- [25] IETF RFC 4585 (2006): "Extended RTP Profile for Real-time Transport Control Protocol (RTCP) - Based Feedback (RTP/SA VPF)".
- [26] 3GPP TS 26.114: "IP Multimedia Subsystem (IMS); Multimedia telephony; Media handling and interaction".
- [27] 3GPP TS 33.210: "Technical Specification Group Services and System Aspects; 3G Security; Network Domain Security; IP Network Layer Security".
- [28] IETF RFC 3556 (2003): "Session Description Protocol (SDP) Bandwidth Modifiers for RTP Control Protocol (RTCP) Bandwidth".
- [29] IETF RFC 4568 (2006): "Session Description Protocol (SDP) Security Descriptions for Media Streams".
- [30] IETF RFC 3711 (2004): "The Secure Real-time Transport Protocol (SRTP)".
- [31] IETF RFC 5124 (2008): "Extended Secure RTP Profile for Real-time Transport Control Protocol (RTCP)-Based Feedback (RTP/SA VPF)".

- [32] IETF RFC 2216 (1997): "Network Element Service Specification Template".
- [33] Supplement 7 to ITU-T H-series Recommendations H.Sup7 (05/2008): "Gateway control protocol: Establishment procedures for the H.248 MGC-MG control association".
- [34] 3GPP TS 33.328: "IMS Media Plane Security".
- [35] Void
- [36] Void
- [37] Void
- [38] 3GPP TS 23.237: "IP Multimedia subsystem (IMS) Service Continuity; Stage 2".
- [39] 3GPP TS 22.153: "Multimedia Priority Service".
- [40] ITU-T Recommendation H.248.82 (03/2013): "Gateway control protocol: Explicit Congestion Notification Support".

3 Definitions, symbols and abbreviations

3.1 Definitions

For the purposes of the present document, the following terms and definitions apply.

Address: term used for "network address" (IP address)

Port: term used for "transport port" (L4 port).

Transcoding: transcoding in general is the translation from one type of encoded media format to another different media format, e.g. G.711 A-law to μ -law or vice versa, G.729 to AMR with 4.75 rate.

NOTE 1: The definition of "transcoding" is according clause 3.10/ITU-T Recommendation V.152 [23].

NOTE 2: Transcoding belongs to the category of "media aware" IP-to-IP interworking.

Transport Address: term used for the combination of a *Network Address* and a *Transport Port*.

3.2 Symbols

For the purposes of the present document, the following symbols apply:

Iq Interface between the IMS Application Level Gateway (ALG) (IMS-ALG) and the IMS Access Gateway (IMS-A GW)

3.3 Abbreviations

For the purposes of the present document, the abbreviations defined in 3GPP TR 21.905 [1] apply, with the following additions. An abbreviation defined in the present document takes precedence over the definition of the same abbreviation, if any, in 3GPP TR 21.905 [1].

ABNF	Augmented Backus-Naur Form
ATCF	Access Transfer Control Function
ATGW	Access Transfer Gateway
DSCP	Differentiated Service Code Point
ECN	Explicit Congestion Notification
IMS-A GW	IMS Access Gateway
IMS-ALG	IMS Application Level Gateway
IP	Internet Protocol

LD	Local Descriptor (H.248 protocol element)
MG	Media Gateway
MGC	Media Gateway Controller
MPS	Multimedia Priority Service
NA	Not Applicable
NAPT	Network Address and Port Translation
NAPT-PT	NAPT and Protocol Translation
NAT	Network Address Translation
RD	Remote Descriptor (H.248 protocol element)
RTCP	RTP Control Protocol
SCTP	Stream Control Transport Protocol
SRVCC	Single Radio Voice Call Continuity
ToS	Type-of-Service
TISPAN	Telecommunications and Internet converged Services and Protocols for Advanced Networking

4 Applicability

The support of the Iq interface capability set shall be identified by the H.248 Iq profile and support of this profile shall be indicated in H.248 ServiceChange procedure (during the (re-)registration phase(s)).

4.1 Architecture

See Annex G of 3GPP TS 23.228 [2].

5 Profile Description

5.1 Profile Identification

Table 5.1.1: Profile Identification

Profile name:	threeglq
Version:	2

5.2 Summary

This Profile describes the minimum mandatory settings and procedures required to fulfil the requirements of the Iq interface (see 3GPP TS 23.334 [23]):

- allocation and translation of IP addresses and port numbers (NA(P)T and NA(P)T-PT);
- opening and closing gates (i.e. packets filtering depending on "IP address / port");
- remote NA(P)T traversal;
- policing of incoming traffic;
- QoS packet marking for outgoing traffic;
- IP realm/domain indication;
- Hanging termination detection;
- RTCP handling;
- Explicit Congestion Notification support;

- Multimedia Priority Service;

and when ATCF/ATGW is supported:

- handover of bearer connections between PS and CS access networks;
- IP version interworking;
- audio transcoding.

In addition, optional settings and procedures are described which fulfil optional features and where supported, the minimum mandatory settings within the optional procedures and packages are identified that must be supported in order to support that feature.

"Optional" or "O" means that it is optional for either the sender or the receiver to implement an element. If the receiving entity receives an optional element that it has not implemented it should send an Error Code (e.g. 445 "Unsupported or Unknown Property", 501 "Not Implemented", etc.). "Mandatory" or "M" means that it is mandatory for the receiver to implement an element. Whether it is mandatory for the sender to implement depends on specific functions; detail of whether elements of the core protocol are mandatory to be sent are defined in the stage 2 procedures, stage 3 procedures and/or the descriptions of individual packages.

The setting or modification of elements described in the profile under the heading "Used in Command" has the meaning that the property can be set/modified with that command. The property may be present in other commands (in order to preserve its value in accordance with ITU-T Recommendation H.248.1 [10]) when those commands are used for other procedures that affect the same descriptor.

5.3 Gateway Control Protocol Version

Version 2 (ITU-T Recommendation H.248.1 [10]) shall be used as minimum protocol version.

5.4 Connection model

Table 5.4.1: Connection Model

Maximum number of contexts:	Provisioned
Maximum number of terminations per context:	3
Allowed terminations type combinations:	(IP,IP) ; (IP,IP,IP) (NOTE)
NOTE:	This is only a temporary context configuration, occurring during bearer access transfer phase (between PS to CS access networks or vice versa).

5.5 Context attributes

Table 5.5.1: Context Attributes

Context Attribute	Supported	Values Supported
Topology	Yes (NOTE 1)	See clause 5.7.9
Priority Indicator	Optional (NOTE 2)	0-15 (NOTE 3)
Emergency Indicator	Yes	YES/NO
IEPS Indicator	No	NA
ContextAttribute Descriptor	No	NA
ContextIdList Parameter	No	NA
AND/OR Context Attribute	No	NA
NOTE 1:	Stream ID in Topology Descriptor shall not be supported (because only used for SRVCC service support, which is a monomedia type of call ("voice call")).	
NOTE 2:	This Context Attribute parameter is allowed in ETSI TISPAN Ia Profile version 3. It is also used for MPS as specified in 3GPP TS 22.153 [39].	
NOTE 3:	Priority values 11 – 15 of the Priority Indicator are reserved for MPS.	

5.6 Terminations

5.6.1 Termination names

5.6.1.1 IP Termination

5.6.1.1.1 ABNF Coding Overview and prose specification

The Termination ID structure shall follow the guidelines of H.248 and shall be based on four fields:

- "ip/<group>/<interface>/<id>".

The individual fields are described and defined in table 5.6.1.1.1.1.

Table 5.6.1.1.1.1: IP Termination Fields

Name	Description	Values	CHOOSE Wildcard	ALL Wildcard
Ip	"ip" is a fixed prefix identifying the termination	"ip"	No	No
Group	Group of Interface and Id	Integer (0-65535)	Yes (NOTE 5)	Yes
Interface	Logical or physical interface to a network to/from which the termination will be sending/receiving media. (NOTE 1, NOTE 2)	String of max 51 alphanumeric characters	Yes (NOTE 4)	Yes
Id	Termination specific identifier (NOTE 3)	Non-zero 32 bit integer	Yes (NOTE 4)	Yes

NOTE 1: A specific <Interface> may be used together with different groups.
 NOTE 2: The generic field <Interface> may relate specifically to an "IP interface", "protocol layer 2 interface" or others.
 NOTE 3: The combination of Interface and Id is unique.
 NOTE 4: The MGC shall always use CHOOSE in an ADD request command. If not, the MG shall reply with an error descriptor using error code #501 "Not Implemented".
 NOTE 5: The CHOOSE wildcard on 'Group' is *not* allowed in ETSI TISPAN "Ia Profiles".

NOTE: The IMS-ALG has the ability to choose the address space in which the IMS-A GW will allocate an IP address for the termination by using the *ipdc/realm* property defined in the ITU-T Recommendation H.248.41 IP domain connection package.

H.248 wildcarding may be applied on IP Termination Identifiers. Wildcarding is limited according the two columns on the right hand side.

The corresponding ABNF grammar is given below.

ABNF (IETF RFC 5234 [15]) is used for the syntax specification. The ABNF for TerminationID and relation to pathNAME is defined in annex B.2/ ITU-T Recommendation H.248.1 [10].

```

pathNAME      = EphToken SLASH EPHsystem
EphToken      = "ip"                ; prefix
EPHsystem    = WildcardALL
              / WildcardALL SLASH Interface
              / Group SLASH WildcardALL
              / (Group / WildcardCHOOSE) SLASH (Interface / WildcardCHOOSE) SLASH (Identifier
              / WildcardALL / WildcardCHOOSE)

Group         = %d0-65535           ; data type: INT16
Interface    = 1*51ALPHANUM
Identifier    = %d1-4294967295     ; data type: INT32
ALPHANUM     = ALPHA / DIGIT
WildcardCHOOSE = "$"
WildcardALL  = "*"

```

5.6.1.1.2 ASN.1 Coding Overview and prose specification

The following general structure of termination ID shall be used:

4 octets shall be used for the termination ID. The following defines the general structure for the termination ID:

Table 5.6.1.1.2.1: ASN.1 coding

Termination type	X
------------------	---

Termination type:

Length 3 bits

Values:

000 Reserved

001 IP (Ephemeral) termination

010 Reserved (in 3GPP Mc and Mn profile used for TDM termination)

011 - 110 Reserved

111 Reserved for ROOT termination Id (ROOT Termination ID = 0xFFFFFFFF)

X:

Length 29 bits.

For IP termination, its usage is un-specified.

5.6.2 Multiplexed terminations

Table 5.6.2.1: Multiplexed terminations

Multiplex terminations supported?	No
--	----

If yes, then:

Table 5.6.2.2: Multiplex Types

Multiplex types supported	NA
Maximum number of terminations connected to multiplex	NA

5.7 Descriptors

5.7.1 TerminationState Descriptor

Table 5.7.1.1: ServiceState property

ServiceState property used:	Yes (InService/OutOfService) NOTE 1, NOTE 2
NOTE 1: This is restricted to the ROOT termination (for MGW audit).	
NOTE 2: Ephemeral H.248 Terminations have a ServiceState property according to ITU-T Recommendation H.248.1 [10], but explicit usage of the TerminationState Descriptor ServiceState property is not required by this Profile. ServiceState changes can still occur, however, and can be indicated in ServiceChange Commands (i.e. this means that the value of the ServiceState property may be implicitly changed by ServiceChange procedures).	

Table 5.7.1.2: EventBufferControl property

EventBufferControl property used:	No
--	----

5.7.2 Stream Descriptor

5.7.2.0 General

Table 5.7.2.1: Stream descriptors

Maximum number of streams per termination type	IP	Unspecified (NOTE)
NOTE : At least one stream for each media component (e.g. video+audio = 2 streams). If only one stream is applicable, then the IMS-ALG may omit the Stream Descriptor and the IMS-AGW shall assume that StreamID = 1.		

Table 5.7.2.2: Stream configuration

Stream configuration:	ALL configurations are allowed
-----------------------	--------------------------------

5.7.2.1 LocalControl Descriptor

Table 5.7.2.1.1: Local Control Descriptor

		Termination Type	Stream Type
ReserveGroup used:	No	NA	NA
ReserveValue used:	Yes	IP	Audio, Video (NOTE)
NOTE: The value of the H.248 Stream Type is given here by the SDP "m=" line element media type (in contrast to the SDP "m=" line element transport protocol in Table 5.7.2.1.2). Usage of ReserveValue implies thus media type aware Local and Remote Descriptors.			

Table 5.7.2.1.2: Allowed Stream Modes

Termination Type	Stream Type	Allowed StreamMode Values
IP	RTP/AVP	SendOnly, RecvOnly, SendRecv, Inactive
	RTP/SAVP	SendOnly, RecvOnly, SendRecv, Inactive
	RTP/AVPF	SendOnly, RecvOnly, SendRecv, Inactive
	RTP/SAVPF	SendOnly, RecvOnly, SendRecv, Inactive
	TCP	SendRecv, Inactive
	TCP/MSRP	SendRecv, Inactive
	UDPTL	SendRecv, Inactive
	UDP	SendOnly, RecvOnly, SendRecv, Inactive

5.7.3 Events descriptor

Table 5.7.3.1: Events Descriptor

Events settable on termination types and stream types:	Yes		
<i>If yes</i>	EventID	Termination Type	Stream Type

Cause (g/cause, 0x0001/0x0001) - See sub-clause 5.14.3.1	ALL except ROOT	ANY
Inactivity Timeout (it/ito, 0x0045/0x0001) – See subclause 5.14.3.6	only ROOT	Not applicable
MG_Overload (ocp/mg_overload, 0x0051/0x0001) – See sub-clause 5.14.3.8	only ROOT	Not applicable
Termination Heartbeat (hangterm/thb, 0x0098/0x0001) - See subclause 5.14.3.9	ALL except ROOT	ANY
MGCon (chp/mgcon, 0x0029/0x0001) – See subclause 5.14.3.10	only ROOT	Not Applicable
Available Realms Changed (ipra/arc, 0x00e0/0x0001) – See subclause 5.14.3.11	only ROOT	Not Applicable
IP Flow Stop Detection (adid/ipstop, 0x009c/0x0001) – See subclause 5.14.3.14	ALL except ROOT	Any
ECN Failure (ecnrousfail, 0x010b/0x0001) see subclause 5.14.3.15	IP	RTP based

Table 5.7.3.2: Event Buffer Control

EventBuffer Control used:	No
----------------------------------	----

Table 5.7.3.3: Keep active

KeepActive used on events :	No
------------------------------------	----

Table 5.7.3.4: Embedded events and signals

Embedded events in an Events Descriptor:	No
Embedded signals in an Events Descriptor:	No

Table 5.7.3.5: Regulated Embedded events

Regulated Embedded events are triggered on:	None
--	------

Table 5.7.3.6: ResetEventsDescriptor

ResetEvents Descriptor used with events:	None
---	------

Table 5.7.3.7: Notification Behaviour

NotifyImmediate:	ALL Events
NotifyRegulated:	None
NeverNotify:	None

5.7.4 EventBuffer descriptor

Table 5.7.4.1: Event Buffer Descriptor

EventBuffer Descriptor used:	No	
<i>If yes</i>	EventIDs	-

5.7.5 Signals descriptor

Table 5.7.5.1: Signals Descriptor

The setting of signals is dependant on termination or streams types:	No NOTE – “No” means that all signals can be played on any termination or stream. If “Yes”, any signal not listed below may be played on any termination or stream , except Signals on ROOT termination shall not be supported.		
<i>If yes</i>	SignalID	Termination Type	Stream Type / ID
	Latching (ipnapt/latch, 0x0099/0x0001)	ALL except ROOT	Any

Table 5.7.5.2: Signal Lists

Signals Lists supported:	No		
<i>If yes</i>	Termination Type Supporting Lists :	-	
	Stream Type Supporting lists :	-	
	Maximum number of signals to a signal list:	-	
	Intersignal delay parameter supported:	-	

Table 5.7.5.3: Overriding Signal type and duration

Signal type and duration supported:	No	
<i>If yes</i>	SignalID	Type or duration override
	-	-

Table 5.7.5.4: Signal Direction

Signal Direction supported:	No
------------------------------------	----

Table 5.7.5.5: Notify completion

NotifyCompletion supported:	No	
<i>If yes</i>	SignalID	Type of completion supported
	-	-

Table 5.7.5.6: RequestID Parameter

RequestID Parameter supported:	No
---------------------------------------	----

Table 5.7.5.7: Signals played simultaneously

Signals played simultaneously:	No	
<i>If yes</i>	SignalIDs that can be played simultaneously:	

Table 5.7.5.8: Keep active

KeepActive used on signals:	No
------------------------------------	----

5.7.6 DigitMap descriptor

Table 5.7.6.1: DigitMap Descriptor

DigitMaps supported:	No		
<i>If yes</i>	DigitMap Name	Structure	Timers
	-	-	-

5.7.7 Statistics descriptor

Table 5.7.7.1: Statistics Descriptor support

Statistics supported on:	-
---------------------------------	---

Table 5.7.7.2: Statistics Report on Subtract

Statistics reported on Subtract:	No	
<i>If yes</i>	StatisticIDs reported:	-

5.7.8 ObservedEvents descriptor

Table 5.7.8.1: ObservedEvents Descriptor

Event detection time supported:	No
--	----

5.7.9 Topology descriptor

Table 5.7.9.1: Topology Descriptor

Allowed triples:	(T1, T2, isolate) (T1, T2, bothway)
NOTE:	The Topology Descriptor shall be supported by the MGW and MGC for handover only, when PS-to-CS access transfer is supported.

5.7.10 Error descriptor

Table 5.7.10.1: Error Codes Sent by IMS-ALG

<p>Supported H.248.8 Error Codes:</p>	<p>#400 "Syntax error in message" #401 "Protocol Error" #402 "Unauthorized" #403 "Syntax Error in TransactionRequest" #406 "Version Not Supported" #410 "Incorrect identifier" #411 "The transaction refers to an unknown ContextID" #413 "Number of transactions in message exceeds maximum" #421 "Unknown action or illegal combination of actions" #422 "Syntax Error in Action" #430 "Unknown TerminationID" #431 "No TerminationID matched a wildcard" #442 "Syntax Error in Command" #443 "Unsupported or Unknown Command" #444 "Unsupported or Unknown Descriptor" #445 "Unsupported or Unknown property" #446 "Unsupported or Unknown Parameter" #447 "Descriptor not legal in this command" #448 "Descriptor appears twice in a command" #449 "Unsupported parameter or property value" #450 "No such property in this package" #451 "No such event in this package" #454 "No such parameter value in this package" #455 "Property illegal in this Descriptor" #456 "Property appears twice in this Descriptor" #457 "Missing parameter in signal or event" #458 "Unexpected Event/RequestID" #501 "Not Implemented" #502 "Not ready" #505 "Transaction Request Received before a ServiceChange Reply has been received" #506 "Number of TransactionPendings Exceeded" #533 "Response exceeds maximum transport PDU size"</p>
<p>Supported Error Codes defined in packages:</p>	<p>All error codes defined in supported packages are supported.</p>
<p>NOTE: The error codes listed need not be supplied by the IMS-ALG to differentiate each and every error described by them. The IMS-AGW shall be able to receive the error codes listed.</p>	

Table 5.7.10.2: Error Codes Sent by IMS-AGW:

Supported H.248.8 Error Codes:	#400 "Syntax error in message" #401 "Protocol Error" #402 "Unauthorized" #403 "Syntax Error in TransactionRequest" #406 "Version Not Supported" #410 "Incorrect identifier" #411 "The transaction refers to an unknown ContextID" #412 "No ContextIDs available" #413 "Number of transactions in message exceeds maximum" #421 "Unknown action or illegal combination of actions" #422 "Syntax Error in Action" #430 "Unknown TerminationID" #431 "No TerminationID matched a wildcard" #432 "Out of TerminationIDs or No TerminationID available" #433 "TerminationID is already in a Context" #434 "Max number of Terminations in a Context exceeded" #435 "Termination ID is not in specified Context" #440 "Unsupported or unknown Package" #441 "Missing Remote or Local Descriptor" #442 "Syntax Error in Command" #443 "Unsupported or Unknown Command" #444 "Unsupported or Unknown Descriptor" #445 "Unsupported or Unknown property" #446 "Unsupported or Unknown Parameter" #447 "Descriptor not legal in this command" #448 "Descriptor appears twice in a command" #449 "Unsupported parameter or property value" #450 "No such property in this package" #451 "No such event in this package" #452 "No such signal in this package" #454 "No such parameter value in this package" #455 "Property illegal in this Descriptor" #456 "Property appears twice in this Descriptor" #457 "Missing parameter in signal or event" #471 "Implied Add for Multiplex failure" #500 "Internal software Failure in MG or MGC" #501 "Not Implemented" #502 "Not ready" #505 "Transaction Request Received before a ServiceChange Reply has been received" #506 "Number of TransactionPendings Exceeded" #510 "Insufficient resources" #511 "Temporarily Busy" #512 "Media Gateway unequipped to detect requested Event" #513 "Media Gateway unequipped to generate requested Signals" #515 "Unsupported Media Type" #517 "Unsupported or invalid mode" #522 "Functionality Requested in Topology Triple Not Supported" #526 "Insufficient bandwidth" #529 "Internal hardware failure in MG" #530 "Temporary Network failure" #531 "Permanent Network failure" #532 "Audited Property, Statistic, Event or Signal does not exist" #533 "Response exceeds maximum transport PDU size" #534 "Illegal write of read only property" #542 "Command is not allowed on this termination"
Supported Error Codes defined in packages:	All error codes defined in supported packages need to be supported.
NOTE: The error codes listed need not be supplied by the IMS-AGW to differentiate each and every error described	

by them. The IMS-ALG shall be able to receive the error codes listed.

5.8 Command API

5.8.1 Add

Table 5.8.1.1: Descriptors used by Command Add Request

Descriptors used by Add request:	Media (Stream(LocalControl, Local, Remote)), Event, Signals
---	---

Table 5.8.1.2: Descriptors used by Command Add Reply

Descriptors used by Add reply:	Media (Stream (Local)), Error When command request excludes an Audit Descriptor, the MGW response shall only include descriptors which contained underspecified or overspecified properties in the command request. Furthermore, only those properties that were underspecified or overspecified in the request shall be sent in the reply. Exceptions to this rule are: <ul style="list-style-type: none"> - The Error Descriptor - SDP properties returned in "Reserve AGW Connection Point" and "Reserve and Configure AGW Connection Point" procedures, as specified in 15.17.2.2 and 15.17.2.4.
---------------------------------------	---

5.8.2 Modify

Table 5.8.2.1: Descriptors used by Command Modify Request

Descriptors used by Modify request:	Media (TerminationState, Stream (LocalControl, Local, Remote)), Signals, Event
--	--

Table 5.8.2.2: Descriptors used by Command Modify Reply

Descriptors used by Modify reply:	Media (Stream(Local)), Error When command request excludes an Audit Descriptor, the MGW response shall only include descriptors which contained underspecified or overspecified properties in the command request. Furthermore, only those properties that were underspecified or overspecified in the request shall be sent in the reply. Exceptions to this rule are: <ul style="list-style-type: none"> - The Error Descriptor - SDP properties returned in "Configure AGW Connection Point" procedure as specified in 15.17.2.3.
--	---

5.8.3 Subtract

Table 5.8.3.1: Descriptor used by Command Subtract Request

Descriptors used by Subtract request:	None, Audit() NOTE
NOTE: This requests that no statistics are to be returned	

Table 5.8.3.2: Descriptor used by Command Subtract Reply

Descriptors used by Subtract reply:	None, Error
--	-------------

5.8.4 Move

Table 5.8.4.1: Command Move

Move command used:	No
---------------------------	----

If used:

Table 5.8.4.2: Descriptor used by Move command

Descriptors used by Move request:	-
Descriptors used by Move reply:	-

5.8.5 AuditValue

Table 5.8.5.1: Auditvalue

Audited Properties:	Property Name and Identity	Descriptor
	TerminationState: - Root (MGW Audit)	TerminationState Descriptor
	For Packages: Root	Packages Descriptor
	None (MGW Audit) : - Root	Audit (empty) Descriptor
	IP Realm Availability : - ipra/* (ROOT)	TerminationState Descriptor
	Base root properties : - root* (ROOT)	TerminationState Descriptor
Audited Statistics:		None
Audited Signals :		None
Audited Events:		None
Packages Audit possible:		Yes

5.8.6 AuditCapabilities

Table 5.8.6.1: Auditcapability

Audited Properties:	Property Name and Identity	Descriptor
	None	-
Audited Statistics:		None
Audited Signals :		None
Audited Events:		None

Table 5.8.6.2: Scoped Auditing

Audited Properties / ContextAttributes used for a scoped audit :	None
---	------

5.8.7 Notify

Table 5.8.7.1: Descriptors Used by Notify Request

Descriptors used by Notify Request	ObservedEvents
---	----------------

Table 5.8.7.2: Descriptors Used by Notify Reply

Descriptors used by Notify Reply:	None, Error
--	-------------

5.8.8 ServiceChange

Table 5.8.8.1: ServiceChangeMethods and ServiceChangeReasons sent by IMS-ALG:

Service Change Methods Supported:	ServiceChange Reasons supported:
Handoff (NOTE 2, NOTE 3)	"903 MGC Directed Change" (Optional, NOTE 4)
Restart (NOTE 2)	"901 Cold Boot" (Optional) "902 Warm Boot" (Optional)
Forced (NOTE 2)	"905 Termination Taken Out Of Service" (Optional)
Graceful (NOTE 2)	"905 Termination Taken Out Of Service" (Optional)
NOTE 1: When a Service Change command on the Root termination with a method other than Graceful is sent, the command shall always be sent as the only command in a message. The sending node shall always wait for the reply to a Service Change command on the Root termination with a method other than Graceful before sending further command requests. A Service Change command on the Root termination with method Graceful may be combined with other commands in a single message.	
NOTE 2: ROOT Only.	
NOTE 3: Not involving more than 1 IMS-ALG. This does not preclude the use of the MGCId in a ServiceChange (Handoff) scenario, nor does it change the expected IMS-AGW behaviour upon receipt of such a message, as the IMS-AGW has actually no means to differentiate whether the ServiceChangeMgcId parameter that may be received in a ServiceChange (handoff) message relates to a logical IMS-ALG inside the same IMS-ALG server or is part of another IMS-ALG.	
NOTE 4: Support of this procedure is mandatory in the IMS-AGW.	

Table 5.8.8.2: ServiceChangeMethods and ServiceChangeReasons sent by IMS-AGW:

Service Change Methods Supported:	ServiceChange Reasons supported:
Forced	"904 Termination Malfunction", ALL except ROOT (Optional, NOTE 4) "905 Termination Taken Out Of Service" , ALL (Mandatory) "906 Loss Of Lower Layer Connectivity" , ALL except ROOT (Optional, NOTE 4) "907 Transmission Failure" , ALL except ROOT (Optional, NOTE 4) "908 MG Impending Failure" ROOT only (Mandatory) "910 Media Capability Failure" , ALL except ROOT (Optional, NOTE 4) "915 State Loss" ROOT only (Optional, NOTE 4)
Graceful (NOTE 2)	"905 Termination Taken Out Of Service" , (Optional, NOTE 4) "908 MG Impending Failure" (Optional, NOTE 4)
Disconnected (NOTE 2)	"900 Service Restored" (Mandatory) "916 Packages Change" (Optional) "917 Capability Change" (Optional)
Restart (NOTE 2)	"900 Service Restored" (Mandatory) "901 Cold Boot" (Mandatory) "902 Warm Boot" (Mandatory) "916 Packages Change" (Optional) "917 Capability Change "(Optional)
Handoff (NOTE 2, NOTE 3)	"903 MGC Directed Change" (Mandatory)
NOTE 1: When a Service Change command on the Root termination with a method other than Graceful is sent, the command shall always be sent as the only command in a message. The sending node shall always wait for the reply to a Service Change command on the Root termination with a method other than Graceful before sending further command requests. A Service Change command on the Root termination with method Graceful may be combined with other commands in a single message.	
NOTE 2: ROOT Only.	
NOTE 3: In response to a IMS-ALG Ordered Re-Register (subclause 5.17.3.7).	
NOTE 4: Support of this procedure is mandatory in the IMS-ALG.	

Table 5.8.8.3: Service Change Address

ServiceChangeAddress used:	No
-----------------------------------	----

Table 5.8.8.4: Service Change Delay

ServiceChangeDelay used:	No
<i>If yes</i>	Valid time period:

Table 5.8.8.5: Service Change Incomplete Flag

ServiceChange Incomplete Flag used:	No
--	----

Table 5.8.8.6: Service Change Version

Version used in ServiceChangeVersion:	2 or 3
NOTE: Version 2 shall be supported as the minimum protocol version. See subclause 5.3.	

Table 5.8.8.7: ServiceChangeProfile

ServiceChangeProfile mandatory:	Yes
NOTE: The ServiceChangeProfile is mandatory in the AGW Register, AGW Re-Register and AGW Capability Change procedures.	

Table 5.8.8.8: Profile negotiation

Profile negotiation as per H.248.18:	No
---	----

Table 5.8.8.9: ServiceChangeMGCI

ServiceChangeMGCI used:	Yes
--------------------------------	-----

5.8.9 Manipulating and auditing context attributes

Table 5.8.9.1: Manipulating and auditing context attributes

Context Attributes Manipulated:	Emergency Indicator, Priority Indicator, Topology
Context Attributes Audited:	None

5.9 Generic command syntax and encoding

Table 5.9.1: Encodings

Supported Encodings:	Text (NOTE 1, NOTE 2) and Binary
NOTE 1: The receiver shall be capable of receiving both Short Token Notation and Long Token Notation on an H.248 control association.	
NOTE 2: The transmitter may select between long and short token forms per H.248 control association.	
NOTE 3: ETSI TISPAN "la Profile" [3] uses only text encoding.	

5.10 Transactions

Table 5.10.1: Transactions per Message

Maximum number of TransactionRequests / TransactionReplies / TransResponseAcks / Segment Replies per message:	10 (NOTE)
NOTE: ETSI TISPAN "la Profile" [3] maximum is "1", this is foreseen to be the typical case.	

Table 5.10.2: Commands per Transaction Requests

Maximum number of commands per TransactionRequest:	Unspecified (NOTE)
NOTE: ETSI TISPAN "la Profile" [3] maximum is "2", this is foreseen to be the typical case.	

Table 5.10.3: Commands per Transaction Reply

Maximum number of commands per TransactionReply:	Unspecified (NOTE)
NOTE: ETSI TISPAN "la Profile" [3] maximum is "2", this is foreseen to be the typical case.	

Table 5.10.4: Optional Commands

Commands able to be marked "Optional":	<Add, Modify, Move, Subtract, Auditvalue, Auditcapability, Servicechange, All, None>
--	--

Table 5.10.5: Commands marked for Wildcarded Responses

Wildcarded responses may be requested for:	Subtract
--	----------

Table 5.10.6: Procedures for Wildcarded Responses

Procedures that make use of wildcarded responses:	Release AGW Termination
---	-------------------------

Table 5.10.7: Transaction Timers

Transaction Timer:	Value
normalMGExecutionTime	Provisioned
normalMGCExecutionTime	Provisioned
MGOriginatedPendingLimit	Provisioned
MGCOriginatedPendingLimit	Provisioned
MGProvisionalResponseTimerValue	Provisioned
MGCProvisionalResponseTimerValue	Provisioned

5.11 Messages

It is recommended that IMS-AGW and IMS-ALG names are in the form of fully qualified domain name. For example the domain name of the IMS-ALG may be of the form: "ALG1.whatever.net." and the name of the IMS-AGW may be of the form: "mg1.whatever.net."

The fully qualified domain name will be used by the IMS-AGW and IMS-ALG as part of the "Message Identifier" in the H.248 messages which identifies the originator of the message.

The IMS-ALG domain name is provisioned in the IMS-AGW or retrieved from the DNS using SRV records.

The use of a domain name provides the following benefits:

- IMS-AGWs and IMS-ALGs are identified by their domain name, not their network addresses. Several addresses can be associated with a domain name. If a command cannot be forwarded to one of the network addresses, implementations shall retry the transmission using another address.

NOTE: There are then e.g. multiple numerical address entries per single MGC entity in the "MG database of MGC entries"; see Table 5 in ITU-T H.Sup7 [29].

- IMS-AGWs and IMS-ALGs may move to another platform. The association between a logical name (domain name) and the actual platform are kept in the Domain Name Service (DNS). IMS-AGW and IMS-ALG shall keep track of the record's time-to-live read from the DNS. They shall query the DNS to refresh the information if the time-to-live has expired.

The domain name may be used by IMS-ALG/IMS-AGW for authentication purposes.

5.12 Transport

Specifies what H.248 subseries transports are supported by the profile.

Table 5.12.1: Transport

Supported transports:	<ol style="list-style-type: none"> 1. IPv4-based network control plane: <ul style="list-style-type: none"> • SCTP/IPv4 (Recommended) • UDP/IPv4 (Optional) 2. IPv6-based network control plane: <ul style="list-style-type: none"> • SCTP/IPv6 (Recommended) • UDP/IPv6 (Optional)
NOTE 1: When using SCTP as defined in IETF RFC 4960 [16] the IMS-AGW shall always be the node to perform the "Initiation".	

Table 5.12.2: Segmentation

Segmentation supported:	SCTP: Inherent in Transport UDP: No
--------------------------------	--

Table 5.12.3: Control Association

Control Association Monitoring supported:	Monitoring mechanism is dependent on used H.248 transport (see above table 5.12/1): SCTP: inherent capability of SCTP. UDP: H.248.14 (MG-driven monitoring). Empty AuditValue on ROOT (MGC-driven monitoring).
--	---

5.13 Security

Table 5.13.1: Security

Supported Security:	None
NOTE: IPsec shall not be used by the IMS-ALG or IMS-AGW for the Iq interface. Normally the Iq interface lies within a single operator's secure domain. If this is not the case then a Za interface (Security Gateway deploying IPsec) may be required, however this is a separate logical function/entity and thus is not applicable to the Iq profile, the IMS-ALG or the IMS-AGW. For further details see 3GPP TS 33.210 [27].	

5.14 Packages

5.14.1 Mandatory Packages

Table 5.14.1.1: Mandatory Packages

Mandatory Packages:		
Package Name	PackageID	Version
IP NAPT traversal (ITU-T Recommendation H.248.37 [4])	ipnapt, (0x0099)	1
Generic (ITU-T Recommendation H.248.1 [10], annex E.1)	g, (0x0001)	1
Base root (ITU-T Recommendation H.248.1 [10], annex E.2)	root, (0x0051)	2
Gate management (ITU-T Recommendation H.248.43 [6], Appendix I;	gm, (0x008c)	2
Traffic management (ITU-T Recommendation H.248.53 [7])	tman, (0x008d)	1
IP Domain Connection (ITU-T Recommendation H.248.41 [8])	ipdc, (0x009d)	1
Hanging Termination Detection (ITU-T Recommendation H.248.36 [9])	hangtem, (0x0098)	1
Diffserv (ITU-T Recommendation H.248.52 [12])	ds, (0x008b)	2
RTP Control Protocol Package (ITU-T Recommendation H.248.57 [5])	rtcp, (0x00b5)	1

5.14.2 Optional Packages

Table 5.14.2.1: Optional Packages

Optional Packages:			
Package Name	PackageID	Version	Support dependent on:
Inactivity Timer (ITU-T Recommendation H.248.14 [11])	it, (0x0045)	1	MGC polling by MG. Only applicable for UDP transport.
Media Gateway Overload Control (ITU-T Recommendation H.248.11 [13])	ocp, (0x0051)	1	Support of message throttling, based on rate limitation, from MGC towards MG.
Media Gateway Resource Congestion Handling Package (see ITU-T Recommendation H.248.10 [14])	chp, (0x0029)	1	Support of message throttling, based on percentage limitation, from MGC towards MG.
IP realm availability (ITU-T Recommendation H.248.41 Amendment 1) [8]	ipra (0x00e0)	1	Support of mechanisms allowing the MGC to discover the IP realms that are available at the MG at a certain time and allowing the MG to inform the MGC about any changes in the availability of realms.
Application Data Inactivity Detection (ITU-T Recommendation H.248.40 [24])	adid (0x009c)	1	MGC requires to be explicitly informed of a cessation of an application data flow.
Explicit Congestion Notification for RTP-over-UDP Support (see ITU-T Recommendation H.248.82 [40])	ecnrou (0x010b)	1	Support of Transparent forwarding of ECN packets

5.14.3 Package usage information

5.14.3.1 Generic (g)

Table 5.14.3.1.1: Generic package

Properties	Mandatory/Optional	Used in command	Supported Values	Provisioned Value
None	-	-	-	-
Signals	Mandatory/Optional	Used in command		Duration Provisioned Value
None	-	-		-
	Signal Parameters	Mandatory/Optional	Supported Values	Duration Provisioned Value
	-	-	-	-
Events	Mandatory/Optional	Used in command		
Cause (g/cause, 0x0001/0x0001)	M	ADD, MOD, NOTIFY		
	Event Parameters	Mandatory/Optional	Supported Values	Provisioned Value
	None			
	ObservedEvent Parameters	Mandatory/Optional	Supported Values	Provisioned Value
	General cause (Generalcause, 0x0001)	M	"NR" (0x0001) Normal Release "UR" (0x0002) Unavailable Resources "FT" (0x0003) Failure, Temporary "FP" (0x0004) Failure, Permanent "IW" (0x0005) Interworking Error "UN" (0x0006) Unsupported	Not Applicable
	Failure cause (Failurecause, 0x0002)	O	Octet String	Not Applicable
Events	Mandatory/Optional	Used in command		
Signal Completion. (g/sc, 0x0001/0x0002)	Not Used	-		
	Event Parameters	Mandatory/Optional	Supported Values	Provisioned Value
	-	-	-	-
	ObservedEvent Parameters	Mandatory/Optional	Supported Values	Provisioned Value
	-	-	-	-
Statistics	Mandatory/Optional	Used in command	Supported Values	
None	-	-	-	
Error Codes	Mandatory/Optional			
None	-			

5.14.3.2 Base root (root)

Table 5.14.3.2.1: Base root package

Properties	Mandatory/Optional	Used in command	Supported Values	Provisioned Value
MaxNrOfContexts (root/maxNumberOfContexts, 0x0002/0x0001)	O	AUDITVALUE	ALL	YES
MaxTerminationsPerContext (root/maxTerminationPerContext, 0x0002/0x0002)	O	AUDITVALUE	ALL	YES
normalMGExecutionTime (root/normalMGExecutionTime, 0x0002/0x0003)	O	AUDITVALUE	ALL	YES
normalMGCEExecutionTime (root/normalMGCEExecutionTime, 0x0002/0x0004)	O	AUDITVALUE	ALL	YES
MGCProvisionalResponseTimerValue (root/MGCProvisionalResponseTimerValue, 0x0002/0x0005)	O	AUDITVALUE	ALL	YES
MGCProvisionalResponseTimerValue (root/MGCProvisionalResponseTimerValue, 0x0002/0x0006)	O	AUDITVALUE	ALL	YES
MGCOriginatedPendingLimit (root/MGCOriginatedPendingLimit, 0x0002/0x0007)	O	AUDITVALUE	ALL	YES
MGCOriginatedPendingLimit (root/MGCOriginatedPendingLimit, 0x0002/0x0008)	O	AUDITVALUE	ALL	YES
Signals	Mandatory/Optional	Used in command		Duration Provisioned Value
None	-	-		-
	Signal Parameters	Mandatory/Optional	Supported Values	Duration Provisioned Value
	-	-	-	-
Events	Mandatory/Optional	Used in command		
None	-	-		
	Event Parameters	Mandatory/Optional	Supported Values	Provisioned Value
	-	-	-	-
	ObservedEvent Parameters	Mandatory/Optional	Supported Values	Provisioned Value
-	-	-	-	-
Statistics	Mandatory/Optional	Used in command	Supported Values	
None	-	-	-	
Error Codes	Mandatory/Optional			
None	-			

5.14.3.3 Differentiated Services (ds)

Table 5.14.3.3.1: Differentiated Services package

Properties	Mandatory/Optional	Used in command	Supported Values	Provisioned Value
Differentiated Services Code Point (ds/dscp, 0x008b/0x0001)	M	ADD, MODIFY	ALL	Yes
Tagging Behaviour (ds/tb, 0x008b/0x0002)	O	ADD, MODIFY	ALL	Yes
Signals	Mandatory/Optional	Used in command		Duration Provisioned Value
None	-	-		-
	Signal Parameters	Mandatory/Optional	Supported Values	Duration Provisioned Value
	-	-	-	-
Events	Mandatory/Optional	Used in command		
None	-	-		
	Event Parameters	Mandatory/Optional	Supported Values	Provisioned Value
	-	-	-	-
	ObservedEvent Parameters	Mandatory/Optional	Supported Values	Provisioned Value
	-	-	-	-
Statistics	Mandatory/Optional	Used in command	Supported Values	
None	-	-	-	
Error Codes	Mandatory/Optional			
None	-			

5.14.3.4 Gate Management (gm)

Table 5.14.3.4.1: Gate Management Package

Properties	Mandatory/Optional	Used in command	Supported Values	Provisioned Value
Remote Source Address Filtering (gm/saf,0x008c/0x0001)	M	ADD, MODIFY	ALL	Not Applicable
Remote Source Address Mask (gm/sam,0x008c/0x0002)	O	ADD, MODIFY	ALL	Not Applicable
Remote Source Port Filtering (gm/spf,0x008c/0x0003)	M	ADD, MODIFY	ALL	Not Applicable
Remote Source Port (gm/spr,0x008c/0x0004)	O	ADD, MODIFY	ALL	Not Applicable
Explicit Source Address Setting (gm/esas,0x008c/0x0005)	Not Supported	NONE	-	Not Applicable
Local Source Address (gm/lsa,0x008c/0x0006)	Not Supported	NONE	-	Not Applicable
Explicit Source Port Setting (gm/esps,0x008c/0x0007)	Not Supported	NONE	-	Not Applicable
Local Source Port (gm/lsp,0x008c/0x0008)	Not Supported	NONE	-	Not Applicable
Remote Source Port Range (gm/spr,0x008c/0x000A)	O	ADD, MODIFY	ALL	Not Applicable
Signals	Mandatory/Optional	Used in command		Duration Provisioned Value
None	-	-		-
	Signal Parameters	Mandatory/Optional	Supported Values	Duration Provisioned Value
	-	-	-	-
Events	Mandatory/Optional	Used in command		
None	-	-		
	Event Parameters	Mandatory/Optional	Supported Values	Provisioned Value
	-	-	-	-
	ObservedEvent Parameters	Mandatory/Optional	Supported Values	Provisioned Value
	-	-	-	-
Statistics	Mandatory/Optional	Used in command	Supported Values	
Discarded Packets	NOT USED	-	-	
Error Codes	Mandatory/Optional			
None	-			

5.14.3.5 Traffic management (tman)

Table 5.14.3.5.1: Traffic Management Package

Properties	Mandatory/Optional	Used in command	Supported Values	Provisioned Value
Policing (tman/pol, 0x008d/0x0005)	M	ADD, MODIFY	ALL	Not Applicable
Peak Data Rate (tman/pdr, 0x008d/0x0001)	O	ADD, MODIFY	ALL	Not Applicable
Delay Variation Tolerance (tman/dvt, 0x008d/0x0004)	O	ADD, MODIFY	ALL	ALL
Sustainable Data Rate (tman/sdr, 0x008d/0x0002)	M	ADD, MODIFY	ALL	Not Applicable
Maximum burstsize (tman/mbs, 0x008d/0x0003)	M	ADD, MODIFY	ALL	Not Applicable
Signals	Mandatory/Optional	Used in command		Duration Provisioned Value
None	-	-		-
	Signal Parameters	Mandatory/Optional	Supported Values	Duration Provisioned Value
	-	-	-	-
Events	Mandatory/Optional	Used in command		
None	-	-		
	Event Parameters	Mandatory/Optional	Supported Values	Provisioned Value
	-	-	-	-
	ObservedEvent Parameters	Mandatory/Optional	Supported Values	Provisioned Value
	-	-	-	-
Statistics	Mandatory/Optional	Used in command	Supported Values	
None	-	-	-	
Error Codes	Mandatory/Optional			
None	-			

NOTE: The data rate shall be calculated using the packet size from IP layer upwards. The Token Bucket method as described by ITU-T Recommendation H.248.53 [7] sub-clause 9.4.3 (as per IETF RFC 2216 [32]) shall be followed where SDR = "r" and MBS = "b" (i.e. the additional "M" value does not apply).

5.14.3.6 Inactivity Timer (it)

Table 5.14.3.6.1: Inactivity Timer Package

Properties	Mandatory/Optional	Used in command	Supported Values	Provisioned Value
None	-	-	-	-
Signals	Mandatory/Optional	Used in command		Duration Provisioned Value
None	-	-	-	-
	Signal Parameters	Mandatory/Optional	Supported Values	Duration Provisioned Value
	-	-	-	-
Events	Mandatory/Optional	Used in command		
Inactivity Timeout (it/ito, 0x0045/0x0001)	M	MODIFY, NOTIFY		
	Event Parameters	Mandatory/Optional	Supported Values	Provisioned Value
	Maximum Inactivity Time (mit, 0x0001)	O	ALL	Yes
	ObservedEvent Parameters	Mandatory/Optional	Supported Values	Provisioned Value
	None	-	-	-
Statistics	Mandatory/Optional	Used in command	Supported Values	
None	-	-	-	
Error Codes	Mandatory/Optional			
None	-			

5.14.3.7 IP Domain Connection (ipdc)

Table 5.14.3.7.1: IP domain connection package

Properties	Mandatory/Optional	Used in command	Supported Values	Provisioned Value
IP Realm Identifier (ipdc/realm, 0x009d/0x0001)	M	ADD, MODIFY (NOTE 2)	ALL (NOTE 1)	Yes
Signals	Mandatory/Optional	Used in command		Duration Provisioned Value
None	-	-		-
	Signal Parameters	Mandatory/Optional	Supported Values	Duration Provisioned Value
	-	-	-	-
Events	Mandatory/Optional	Used in command		
None	-	-		
	Event Parameters	Mandatory/Optional	Supported Values	Provisioned Value
	-	-	-	-
	ObservedEvent Parameters	Mandatory/Optional	Supported Values	Provisioned Value
	-	-	-	-
Statistics	Mandatory/Optional	Used in command	Supported Values	
None	-	-	-	
Error Codes	Mandatory/Optional			
No	-			
NOTE 1: If the MGC uses an IP Realm Identifier (<i>ipdc/realm</i>) property exceeding the maximum length limitation defined in ITU-T Recommendation H.248.41 [8], the MG shall reply with an error descriptor using error code #410: "Incorrect identifier".				
NOTE 2: The MODIFY command is listed due to the fact that subsequent Streams may be "added" by MODIFY requests in case of multi-Stream-per-Termination structures. The subsequent Streams shall then carry the same IP Realm Identifier (<i>ipdc/realm</i>) property value as the very first Stream.				

5.14.3.8 Media Gateway Overload Control Package (ocp)

Table 5.14.3.8.1: Media Gateway Overload Control Package

Properties	Mandatory/Optional	Used in command	Supported Values	Provisioned Value
None	-	-	-	-
Signals	Mandatory/Optional	Used in command		Duration Provisioned Value
None	-	-	-	-
	Signal Parameters	Mandatory/Optional	Supported Values	Duration Provisioned Value
	-	-	-	-
Events	Mandatory/Optional	Used in command		
MG_Overload (ocp/mg_overload, 0x0051/0x0001) (NOTE 1)	M	MODIFY, NOTIFY (NOTE 1)		
	Event Parameters	Mandatory/Optional	Supported Values	Provisioned Value
	None	-	-	-
	ObservedEvent Parameters	Mandatory/Optional	Supported Values	Provisioned Value
	None	-	-	-
Statistics	Mandatory/Optional	Used in command	Supported Values	
None	-	-	-	
Error Codes	Mandatory/Optional			
None	-			

NOTE 1: When the MG is overloaded, overload Events may be sent **either** only following the **first ADD.request** which creates a new Context, **or** following **all ADD.request** commands (see ITU-T Recommendation H.248.11 [13] Corrigendum 1).
These two options result in different normalisations of the overload event rate as an indicator of the level of MG overload.

5.14.3.9 Hanging Termination Detection (hangterm)

Table 5.14.3.9.1: Hanging Termination Detection Package

Properties	Mandatory/Optional	Used in command	Supported Values	Provisioned Value
None	-	-	-	-
Signals	Mandatory/Optional	Used in command		Duration Provisioned Value
None	-	-	-	-
	Signal Parameters	Mandatory/Optional	Supported Values	Duration Provisioned Value
	-	-	-	-
Events	Mandatory/Optional	Used in command		
Termination Heartbeat (hangterm/thb, 0x0098/0x0001)	M	ADD, MODIFY, NOTIFY		
	Event Parameters	Mandatory/Optional	Supported Values	Provisioned Value
	Timer X (timerx,0x0001)	M	ALL (NOTE1)	YES
	ObservedEvent Parameters	Mandatory/Optional	Supported Values	Provisioned Value
	-	-	-	-
Statistics	Mandatory/Optional	Used in command	Supported Values	
None	-	-	-	
Error Codes	Mandatory/Optional			
None	-			

NOTE1: The heartbeat timer shall be configured to a value much greater than the mean call holding time.

5.14.3.10 Media Gateway Resource Congestion handling Package (chp)

Table 5.14.3.10.1: Media Gateway Resource Congestion handling Package

Properties	Mandatory/Optional	Used in command	Supported Values	Provisioned Value
None	-	-	-	-
Signals	Mandatory/Optional	Used in command		Duration Provisioned Value
None	-	-	-	-
	Signal Parameters	Mandatory/Optional	Supported Values	Duration Provisioned Value
	-	-	-	-
Events	Mandatory/Optional	Used in command		
MGCon (chp/mgcon, 0x0029/0x0001)	M	MODIFY, NOTIFY		
	Event Parameters	Mandatory/Optional	Supported Values	Provisioned Value
	None	-	-	-
	ObservedEvent Parameters	Mandatory/Optional	Supported Values	Provisioned Value
	Reduction (reduction,0x0001)	M	0-100	Not Applicable
Statistics	Mandatory/Optional	Used in command	Supported Values	
None	-	-	-	
Error Codes	Mandatory/Optional			
None	-			

5.14.3.11 IP Realm Availability (ipra)

Table 5.14.3.11.1: IP Realm Availability Package

Properties	Mandatory/Optional	Used in command	Supported Values	Provisioned Value
Available Realms, (ipra/ar, 0x00e0/0x0001)	M	AUDITVALUE	ALL	Not Applicable
Signals	Mandatory/Optional	Used in command		Duration Provisioned Value
None	-	-		-
	Signal Parameters	Mandatory/Optional	Supported Values	Duration Provisioned Value
	-	-	-	-
Events	Mandatory/Optional	Used in command		
Available Realms Changed, (ipra/arc, 0x00e0/0x0001)	M	MODIFY, NOTIFY		
	Event Parameters	Mandatory/Optional	Supported Values:	Provisioned Value
	-	-	-	-
	ObservedEvent Parameters	Mandatory/Optional	Supported Values	Provisioned Value
	Newly Available Realms (nar, 0x0001)	M	ALL	Not applicable
	Newly Unavailable Realms (nur, 0x0002)	M	ALL	Not applicable
Statistics	Mandatory/Optional	Used in command	Supported Values	
None	-	-	-	
Error Codes	Mandatory/Optional			
None	-			

5.14.3.12 IP NAPT Traversal (ipnapt)

Table 5.14.3.12.1: IP NAPT Traversal Package

Properties	Mandatory/Optional	Used in command	Supported Values	Provisioned Value
None	-	-	-	-
Signals	Mandatory/Optional	Used in command		Duration Provisioned Value
Latching (ipnapt/latch) 0x0099/0x0001)	M	ADD, MODIFY		Not Applicable
	Signal Parameters	Mandatory/Optional	Supported Values	Duration Provisioned Value
	NAPT Traversal Processing (napt, 0x0001)	M	ALL	Not Applicable
Events	Mandatory/Optional	Used in command		
None	-	-		
	Event Parameters	Mandatory/Optional	Supported Values	Provisioned Value
	-	-	-	-
	ObservedEvent Parameters	Mandatory/Optional	Supported Values	Provisioned Value
	-	-	-	-
Statistics	Mandatory/Optional	Used in command	Supported Values	
None	-	-	-	
Error Codes	Mandatory/Optional			
None	-			

5.14.3.13 RTCP Handling Package (rtcp)

Table 5.14.3.13.1: RTCP Handling Package

Properties	Mandatory/Optional	Used in command	Supported Values	Provisioned Value
RTCP Allocation Specific Behaviour (rtcp/rsb,0x00b5/0x0009)	M	ADD, MODIFY	ALL	OFF
Signals	Mandatory/Optional	Used in command		Duration Provisioned Value
None	-	-		-
	Signal Parameters	Mandatory/Optional	Supported Values	Duration Provisioned Value
	-	-	-	-
Events	Mandatory/Optional	Used in command		
None	-	-		
	Event Parameters	Mandatory/Optional	Supported Values	Provisioned Value
	-	-	-	-
	ObservedEvent Parameters	Mandatory/Optional	Supported Values	Provisioned Value
	-	-	-	-
Statistics	Mandatory/Optional	Used in command	Supported Values	
None	-	-	-	
Error Codes	Mandatory/Optional			
None	-			

5.14.3.14 Application Data Inactivity Detection (adid)

Table 5.14.3.14.1: Application Data Inactivity Detection package

Properties	Mandatory/Optional	Used in command	Supported Values	Provisioned Value
None	-	-	-	-
Signals	Mandatory/Optional	Used in command		Duration Provisioned Value
None	-	-		-
	Signal Parameters	Mandatory/Optional	Supported Values	Duration Provisioned Value
	-	-	-	-
Events	Mandatory/Optional	Used in command		
IP Flow Stop Detection (adid/ipstop, 0x009c/0x0001)	M	ADD, MODIFY, NOTIFY		
	Event Parameters	Mandatory/Optional	Supported Values	Provisioned Value
	Detection time (dt, 0x0001)	M	ALL	Yes
	Direction (dir, 0x002)	M	ALL	Yes
	ObservedEvent Parameters	Mandatory/Optional	Supported Values	Provisioned Value
None	-	-	-	
Statistics	Mandatory/Optional	Used in command	Supported Values	
None	-	-	-	
Error Codes	Mandatory/Optional			
None				

5.14.3.15 Explicit Congestion Notification for RTP-over-UDP Support (ecnrous)

Table 5.14.3.15.1: Explicit Congestion Notification for RTP-over-UDP Support package

Properties	Mandatory/Optional	Used in command	Supported Values	Provisioned Value
ECN Enabled (ecnrous/ecnen, 0x010b/0x0001)	M	ADD, MODIFY	True, False	-
Congestion Response Method (ecnrous/cm, 0x010b/0x0002)	Not Signalled	-	-	"RDCC"(0x0002) (NOTE 1, NOTE 2)
Initiation Method (ecnrous/initmethod, 0x010b/0x0003)	M	ADD, MODIFY	"inactive", "leap"	"inactive"
ECN Mode (ecnrous/mode, 0x010b/0x0004)	Not Signalled	-	-	"setonly" (0x0001) in the Remote Descriptor and "readonly" (0x0002) in the Local Descriptor
ECT Marking (ecnrous/ectmark, 0x010b/0x0005)	Not Signalled	-	-	"0" (0x0002) (NOTE 2)
ECN Congestion Marking (ecnrous/congestmark, 0x010b/0x0006)	Not Signalled	-	-	"nomark" (0x0003)
ECN SDP Usage (ecnrous/ecnsdp, 0x010b/0x0007)	Not Signalled	-	-	"P" (0x0001)
Signals	Mandatory/Optional	Used in command		Duration Provisioned Value
None	-	-		-
	Signal Parameters	Mandatory/Optional	Supported Values	Duration Provisioned Value
	-	-	-	-
Events	Mandatory/Optional	Used in command		
ECN Failure (ecnrous/fail, 0x010b/0x0001)	O (NOTE 2)	ADD, MODIFY, NOTIFY		
	Event Parameters	Mandatory/Optional	Supported Values	Provisioned Value
	-	-	-	-
	-	-	-	-
	ObservedEvent Parameters	Mandatory/Optional	Supported Values	Provisioned Value
	Failure Type (type,0x0001)	Mandatory	INIT, USE	
	Media Sender SSRC (ssrc, 0x0002)	Not Supported		
Statistics	Mandatory/Optional	Used in command	Supported Values	
Source (ecnrous/ssrc, 0x010b/0x0001)	Not Supported	-	-	
CE Counter (ecnrous/cecount, 0x010b/0x0002)	Not Supported	-	-	
ECT0 Counter (ecnrous/ectzero, 0x010b/0x0003)	Not Supported	-	-	
ECT1 Counter (ecnrous/ectone, 0x010b/0x0004)	Not Supported	-	-	
Not-ECT Counter (ecnrous/notect, 0x010b/0x0005)	Not Supported	-	-	
Lost Packets Counter (ecnrous/lost 0x010b/0x0006)	Not Supported	-	-	
Extended Highest Sequence number (ecnrous/ehsn, 0x010b/0x0007)	Not Supported	-	-	
Duplication Counter (ecnrous/dup, 0x010b/0x0008)	Not Supported	-	-	
Error Codes	Mandatory/Optional			
None	-			

<p>NOTE 1: Application Specific Rate Adaptation shall be applied in accordance with 3GPP TS 26.114 [26]. For speech this requires support of CMR and TMMBR for video.</p> <p>NOTE 2: Not used for ECN transparent. Mandatory for ECN endpoint.</p>
--

5.15 Mandatory support of SDP and Annex C information elements

Table 5.15.1: Mandatory Annex C and SDP information elements

Information Element	Annex C Support	SDP Support
v-line	"SDP_V"	The value must always be equal to zero: v=0
c-line	"SDP_C"	<p><nettype> <addrtype> and <connection address> are required. The network type shall be set to "IN". The address type may be IPv4 or IPv6. The MGC may apply parameter underspecification to the <connection address> subfield.</p>
m-line	"SDP_M"	<p>There are four fields (or SDP values) <media>, <port>, <proto> and <fmt> in the "m=" line (see IETF RFC 4566 [17];NOTE 1). The "m=" line may be omitted from SDP.</p> <p><media>, <port>, <proto > and <fmt-list> are required if the "m=" line is included.</p> <p>Media type <media> :</p> <p>The <media> field shall be set to "audio" or "video" or "-". When "-" is used for the <i>media</i> value then no media resources are required to be reserved at this stage (NOTE 1). If the MG does not support the requested media value it shall reject the command with error code 515.</p> <p>Transport port <port> The <i>port</i> value may be underspecified with CHOOSE wildcard.</p> <p>Transport protocol <proto> As in table 5.15.2.</p> <p>Media format <fmt> Various values may be used for media-format, dependent on the related <media>.</p> <p>"-" may be used for the <i>format list</i> value if no media reservation is required at this stage. If the MG does not support the requested media format value the MG shall reject the command with error code 449.</p>
b-line	"SDP_B"	<p>Shall not be used without a "m=" line.</p> <p>The <i>modifier</i> values shall be "AS", "RS" and "RR".</p> <p>The AS <i>modifier</i> implies that the <i>bandwidth-value</i> represents the "maximum bandwidth" (see clause 5.8/ IETF RFC 4566 [17]). The <i>bandwidth-value</i> relates therefore to the <i>peak bitrate</i> (NOTE 2).</p> <p>The <i>bandwidth-value</i> value defines the IP layer bandwidth for the specific H.248 Stream.</p> <p>For RTP flows, where RTCP resources are reserved together with the RTP resources using the "RTP Specific Behaviour" property of the Gate Management package (gm) property, the IMS-ALG may also supply additional RTCP bandwidth modifiers (i.e. RR and RS, see IETF RFC 3556 [28]). The AS <i>bandwidth</i> value will include the bandwidth used by RTP. In the absence of the RTCP bandwidth modifiers the IMS-AGW shall allow an additional 5% of the AS bandwidth value for the bandwidth for RTCP, in accordance with IETF RFC 3556 [28].</p>

o-line	"SDP_O"	<p>The origin line consists of six fields: (<username>, <sess-id>, <sess-version>, <nettype>, <addrtype> and <unicast-address>).</p> <p>The MGC is not required to supply this line but shall accept it (see clause 7.1.8/ITU-T Recommendation H.248.1 [10]).</p> <p>The MG shall return the value received from the MGC or if there is no o-line sent by the MGC, the MG shall populate this line as follows:</p> <ul style="list-style-type: none"> - <user name> should contain an hyphen - <session ID> and <version> should contain one or more digits as described in IETF RFC 4566 [17] - <network type> shall be set to IN - <address type> shall be set to IP4 or IP6 The Address Type shall be set to "IP4" or "IP6" depending on the addressing scheme used by the network to which the MG is connected. - <address> should contain the fully qualified domain name or IP address of the gateway.
s-line	"SDP_S"	<p>The session name "s=" line contains a single field s= <session name>.</p> <p>The MGC is not required to supply this line but shall accept it (see clause 7.1.8/ITU-T Recommendation H.248.1 [10]).</p> <p>The MG shall return the value received from the MGC or if there is no s-line sent by the MGC, the MG shall populate this line as follows:</p> <p>"s=-"</p>
t-line	"SDP_T"	<p>The time "t=" line consists of two fields t= <start time> and <stop time>.</p> <p>The MGC is not required to supply this line but shall accept it (see clause 7.1.8/ITU-T Recommendation H.248.1 [10]).</p> <p>The MG shall return the value received from the MGC or if there is no t-line sent by the MGC, the MG shall populate this line as follows:</p> <p>"t=0 0"</p>
<p>NOTE 1: IETF RFC 4566 [17] enables "-" as a valid character.</p> <p>NOTE 2: The unit for the <i>bandwidth-value</i> (peak bitrate) is "kbits". The "b=" line is not providing any information about the traffic characteristic, i.e. whether the traffic flow has a Constant BitRate (CBR) or Variable BitRate (VBR). The <i>bandwidth-value</i> is thus independent of the traffic characteristic and relates to the peak bitrate for CBR and VBR traffic.</p>		

Table 5.15.2: Transport Protocol

Transport Protocol <proto> in m-line:	If the MG does not support the requested transport protocol, it shall reject the command with error code 449.
udp	Allow only L4 protocol = UDP (NOTE 1).
TCP	Allow only L4 protocol = TCP (NOTE 2)
TCP/MSRP	Message service using IETF RFC 4975 [18].
RTP/AVP	RTP profile according IETF RFC 3551 [19]. Allow only L4 protocol = UDP (see NOTE 1)
RTP/SAVP	SRTP profile according IETF RFC 3711 [30] (NOTE 3). Allow only L4 protocol = UDP (see NOTE 1)
RTP/SAVPF	Extended SRTP profile for RTCP-based Feedback (RTP/SAVPF) according IETF RFC 5124 [31] (NOTE 3).. Allow only L4 protocol = UDP (see NOTE 1)
RTP/AVPF	Extended RTP profile for RTCP-based Feedback (RTP/AVPF) according IETF RFC 4585 [25]. See 3GPP TS 26.114 [26]. Allow only L4 protocol = UDP (see NOTE 1)
udptl	Allow only L4 protocol = UDP

NOTE 1: Parameter "udp" is introduced by IETF RFC 4566 [17] but not yet registered by IANA (see <http://www.iana.org/assignments/sdp-parameters>).

NOTE 2: Upper case TCP is defined by IETF RFC 4145 [20] and registered by IANA.

NOTE 3: The IMS AGW does not need to reserve resources for end-to-access media security en-/decryption at this stage if RTP profile identifiers "RTP/SAVP" or "RTP/SAVPF" are signalled without the "a=crypto" property for that stream. For e2e media security either "RTP/SAVP" is signalled at all terminations in a context, or "RTP/SAVPF" is signalled at all terminations in a context and no media attribute will be signalled; the IMS AGW shall then not terminate the SRTP / SRTCP protocol, but shall pass the encrypted media and control flows (as indicated with the rtcp/rsb property) transparently.

5.16 Optional support of SDP and Annex C information elements

Specifies what SDP attributes and Annex C information elements may be supported.

Table 5.16.1: Optional Annex C and SDP information elements

Information Element	Annex C Support	SDP Support
a-line	"SDP_A"	<p>1) Application "RTCP transport address control": The attribute "a=rtcp" line may either contain (a=rtcp: <port>) or (a=rtcp: <port> <network type> <address type> <connection address>) when the "a=" line is used for RTCP transport port and optionally network address transmission (see IETF RFC 3605 [21]). . The MGC shall supply the "a=rtcp" line in the RD when non-default RTCP network address or transport port values are used by the peer media entity. "RTCP transport address control" should be supported by MG.</p> <p>2) Media related parameters in general: The "a=" line provides the complementary information for the "m=" line with regards to a specified media type/format (e.g. an optional SDP „a=ptime" line for a particular media format). For a dynamic RTP payload type, for each media information on the codec type shall be provided in a separate SDP "a=rtpmap" line and possibly additional SDP "a=fmtp"-line(s).</p> <p>3) Application "Media interworking (transcoding)": See "a=" line specification in (2). Media interworking is limited to audio transcoding only.</p> <p>4) IMS media plane security related parameters: The attribute "a=crypto" (see IETF RFC 4568 [29]) shall be provided for an m-line in the local and remote descriptor of an access network termination if the IMS-ALG wants that the corresponding media is encrypted, decrypted and/or integrity protected by the IMS-AGW (IMS end-to-access-edge media plane security). For each m-line, only a single "a=crypto" attribute shall be provisioned (i.e. only information related to a single crypto suite is provisioned to the IMS-AGW). The "a=crypto" attribute may contain several master keys. An IMS-AGW supporting end-to-access-edge media plane security shall support parameters within the "a=crypto" attribute in accordance with the profile in Annex of 3GPP TS 33.328 [34].</p>
NOTE: Media Interworking is optional.		

5.17 Procedures

5.17.1 Formats and Codes

Table 5.17.1.1 shows the parameters which are required for the procedures defined in the following clauses.

The coding rules applied in ITU-T Recommendation H.248.1 [10] for the applicable coding technique shall be followed for the UMTS capability set.

The binary encoding rules which are applicable to the defined Abstract Syntaxes are the Basic Encoding Rules for Abstract Syntax Notation One, defined in ITU-T Recommendation X.690 [22]. Specifically in accordance with ITU-T Recommendation X.690 [22] section 7.3, alternative encodings based on the definite and indefinite form of length are permitted by the basic encoding rules as a sender's option. Receivers shall support both alternatives.

Unsupported values of parameters or properties may be reported by the IMS-AGW and shall be supported by the IMS-ALG as such by using H.248.1 error code #449 "Unsupported or Unknown Parameter or Property Value ". The unsupported or unknown value is included in the error text in the error descriptor.

Table 5.17.1.1: Information Elements Used in Procedures

Signalling Object	H.248 Descriptor	Coding
Alternate MGC Id	ServiceChange	The MGCIdToTry parameter in ITU-T Recommendation H.248.1 [10].
Available Realms	Termination State	According to <i>Available Realms</i> property in ITU-T Recommendation H.248.41 [8].
BNC Release	Events, ObservedEvents	As for the Events/ObservedEvents Descriptor in subclause E.1.2.1/ ITU-T Recommendation H.248.1 [10] "Cause"
Cause	ObservedEvents	As for the ObservedEvent Parameter in subclause E.1.2.1/ ITU-T Recommendation H.248.1 [10] "General cause"
Changed Realms	Observed Events	According to Observed Events Parameters for <i>Available Realms Changed</i> event in ITU-T Recommendation H.248.41 [8].
Codec List	Local Descriptor or Remote Descriptor	<fmt list> in a single SDP m-line. For a static RTP payload type, the codec type should be implied by the RTP payload type, if not then each codec type shall be provided in a separate SDP "a=rtpmap"-line and possibly additional SDP "a=fmtp"-line(s). For a dynamic RTP payload type, for each codec information on the codec type shall be provided in a separate SDP "a=rtpmap"-line and possibly additional SDP "a=fmtp"-line(s).
Connectivity Mode	Local Control	ITU-T Recommendation H.248.1 [10] Mode property. Binary Encoding: Encoding as per ITU-T Recommendation H.248.1 Annex A [10] "streamMode" Textual Encoding: Encoding as per ITU-T Recommendation H.248.1 Annex B [10] "streamMode".
Context ID	NA	Binary Encoding: As per ITU-T Recommendation H.248.1 [10] Annex A. Textual Encoding: As per ITU-T Recommendation H.248.1 [10] Annex B.
Cryptographic SDES Attribute	Local Descriptor or Remote Descriptor	"crypto" attribute in SDP a-line as defined in IETF RFC 4568 [29], see 5.16
Delay Variation Tolerance	Local Control	This is the tman/dvt property from ITU-T Recommendation H.248.53 [7].
Diffserv Code Point	Local Control	Defined according to the <i>Differentiated Services Code Point</i> property in ITU-T Recommendation H.248.52 [12].
Diffserv Tagging Behaviour	Local Control	Defined according to the <i>Tagging Behaviour</i> property in ITU-T Recommendation H.248.52 [12].
ECN Enabled	Local Descriptor or Remote Descriptor	Defined according to the "ECN Enabled" property in ITU-T Recommendation H.248.82 [40].
ECN Failure	Events, Observed Events	Defined according to the "ECN Failure" Event in ITU-T Recommendation H.248.82 [40].
ECN Failure Type	ObservedEvents Descriptor	As for the ObservedEventsDescriptor Parameter "Failure Type" in ITU-T Recommendation H.248.82 [40].
ECN Initiation Method	Local Descriptor or Remote Descriptor	Defined according to "Initiation Method" property in ITU-T Recommendation H.248.82 [40].
Emergency Call Indication	NA	ITU-T Recommendation H.248.1 [10] 6.1.1 Emergency Call Indicator Binary Encoding: Encoding as per ITU-T Recommendation H.248.1 [10] Annex A "Emergency" context attribute Textual Encoding: Encoding as per ITU-T Recommendation H.248.1 [10] Annex B "EmergencyToken" context attribute
Inactivity Timer	Events, Observed Events	Defined according to <i>Inactivity Timeout</i> event in ITU-T Recommendation H.248.14 [11].
IP Address	Local Descriptor or Remote Descriptor	<connection address> in SDP "c-line"
IP Realm	Local Control	According to <i>IP Realm Identifier</i> property in ITU-T Recommendation H.248.41 [8].
IP Version	Local Descriptor or Remote Descriptor	<address type> in SDP "c-line", see 5.15
Latching	Signals	This is the ipnapt/latch signal in ITU-T Recommendation H.248.37 [4].
Maximum Burst Size	Local Control	This is the tman/mbs property from ITU-T Recommendation H.248.53 [7].
Media Inactivity Detection	Events, Observed Events	Defined according to <i>ipstop</i> event in ITU-T Recommendation H.248.40 [24].
Media Inactivity Detection	Events	As for the Event Parameter in ITU-T Recommendation H.248.40 [24].

Time		"Detection Time"
Media Inactivity Detection Direction	Events	As for the Event Parameter in ITU-T Recommendation H.248.40 [24] "Direction"
Media Type	Local Descriptor or Remote Descriptor	<media> in SDP m-line "audio" or "video" or "-"
Overload Notification	Events, ObservedEvents	This is the chp/mgcon event from ITU-T Recommendation H.248.10 [14] or the ocp/mg_overload event from ITU-T Recommendation H.248.11 [13].
Peak Data Rate	LocalControl	This is the tman/pdr property from ITU-T Recommendation H.248.53 [7].
Policing Required	LocalControl	This is the tman/pol property from ITU-T Recommendation H.248.53 [7].
Port	Local Descriptor or Remote Descriptor	<port> in SDP m-line.
Priority Information	NA	Priority Indicator (subclause 6.1.1 of ITU-T Recommendation H.248.1 [10]) Binary Encoding: Encoding as per ITU-T Recommendation H.248.1 [10] Annex A "priority" context attribute Textual Encoding: Encoding as per ITU-T Recommendation H.248.1 [10] Annex B "priority" context attribute
Realm Availability Change	Events, Observed Events	According to <i>Available Realms Changed</i> event in ITU-T Recommendation H.248.41 [8].
Reduction	ObservedEvent Descriptor	As for the ObserverdEventDescriptor in subclause 4.2.1/ ITU-T Recommendation H.248.10 [14] "MGCongestion".
Remote Source Address Filtering	Local Control	Defined according to <i>Remote Source Address Filtering</i> property in ITU-T Recommendation H.248.43 [6].
Remote Source Address Mask	Local Control	Defined according to <i>Remote Source Address Mask</i> property in ITU-T Recommendation H.248.43 [6].
Remote Source Port Filtering	Local Control	Defined according to <i>Remote Source Port Filtering</i> property in ITU-T Recommendation H.248.43 [6].
Remote Source Port	Local Control	Defined according to <i>Remote Source Port</i> property in ITU-T Recommendation H.248.43 [6].
Remote Source Port Range	Local Control	Defined according to <i>Remote Source Port Range</i> property in ITU-T Recommendation H.248.43 [6].
Reserve_Value	Local Control	ITU-T Recommendation H.248.1 [10] Reserve property. Binary Encoding: Encoding as per ITU-T Recommendation H.248.1 [10] Annex A "reserveValue" Textual Encoding: Encoding as per ITU-T Recommendation H.248.1 [10] Annex B "reservedValueMode".
ROOT Properties	Termination State	The properties in subclause E.2.1/ ITU-T Recommendation H.248.1 [10]
RTCP allocation	Local Control	Defined according to <i>RTCP Allocation Specific Behaviour</i> property in ITU-T Recommendation H.248.57 [5].
RtcpbwRR	Local Descriptor or Remote Descriptor	<bandwidth> in SDP "b:RR"-line. see 5.15
RtcpbwRS	Local Descriptor or Remote Descriptor	<bandwidth> in SDP "b:RS"-line. see 5.15
Rtpbw	Local Descriptor or Remote Descriptor	<bandwidth> in SDP "b:AS"-line. see 5.15
RTPpayload	Local Descriptor or Remote Descriptor	<fmt list> in SDP m-line. This may be set to CHOOSE (\$) in a LD sent from the IMS-ALG toward the IMS-AGW.
Stream Number	Stream	Encoding as per ITU-T Recommendation H.248.1 [10] Annex B "Stream"/"ST". For a single stream, this may be omitted by the IMS-ALG.
Sustainable Data Rate	Local Control	This is the tman/sdr property from ITU-T Recommendation H.248.53 [7].
Termination heartbeat	Events ObservedEvents	As per <i>Termination Heartbeat</i> defined in ITU-T Recommendation H.248.36 [9] Clause 5.2.1.
Termination ID	NA	Binary Encoding: As per ITU-T Recommendation H.248.1 [10] Annex A. Textual Encoding: As per ITU-T Recommendation H.248.1 [10] Annex B.
Transaction ID	NA	Binary Encoding: As per ITU-T Recommendation H.248.1 [10] Annex A. Textual Encoding: As per ITU-T Recommendation H.248.1 [10] Annex B.

Transport	Local Descriptor or Remote Descriptor	<transport> in SDP m-line, see 5.15
-----------	---------------------------------------	-------------------------------------

5.17.2 Call Related Procedures

5.17.2.1 General

This section describes the various call related procedures performed by the IMS-AGW, which are listed in table 5.17.2.1.1

Table 5.17.2.1.1: IMS-AGW Call Related Procedures

Transaction defined in 3GPP TS 23.334 [23]	Supported	Comment
Reserve AGW Connection Point	Mandatory	See 5.17.2.2
Configure AGW Connection Point	Mandatory	See 5.17.2.3
Reserve and Configure AGW Connection Point	Mandatory	See 5.17.2.4
Release AGW Termination	Mandatory	See 5.17.2.5
Termination Heartbeat Indication	Mandatory	See 5.17.2.6
IP Bearer Released	Mandatory	See 5.17.2.7
Media Inactivity Notification	Optional	See 5.17.2.8
Change Through Connection	Mandatory	See 5.17.2.9
Change Flow Direction	Optional	See 5.17.2.10.
ECN Failure Indication	Optional	See 5.17.2.11 Only applicable if ECN endpoint capability is supported

5.17.2.2 Reserve AGW Connection Point

The IMS-ALG sends an ADD request command as in Table 5.17.2.2.1.

Table 5.17.2.2.1: Reserve AGW Connection Point Request

Address Information	Control information	Bearer information
<p>Local Descriptor { Port = \$ IP Address = \$ IP Version = IPv4 or IPv6 }</p>	<p>Transaction ID = x If Context Requested: Context ID= \$ If Emergency Call: Emergency Call Indication If MPS call/session: Priority Indicator = x If Context Provided: Context ID = c1 Termination ID = \$ If Stream Number specified:- Stream Number If Resources for multiple Codecs required: Reserve_Value If IP Interface Type: IP interface = "IP interface type" If indication on Bearer Released requested: NotificationRequested (Event ID = x, "BNC Release") If diffserv required:- Diffserv Code Point If tagging behaviour Diffserv Tagging Behaviour If Remote Source Address Filtering required:- Remote Source Address Filtering If Remote Source Address range required: Remote Source Address Mask If Remote Source Port Filtering required:- Remote Source Port Filtering If individual port: Remote Source Port If range of ports Remote Source Port Range NotificationRequested (Event ID = x, "termination heartbeat") If IP Realm specified:- IP Realm If Latching Required:- Latching If Sustainable Data Rate Policing Required:- Policing Required Sustainable Data Rate Maximum Burst Size If Peak Data Rate Policing Required: Policing Required</p>	<p>Local Descriptor { If media is "audio" or "video": Codec List = Codec List RTP Payloads = RTP Payload Rtpbw If RTCP bandwidth RtcpbwRS RtcpbwRR If IMS media plane security required: Cryptographic SDES Attribute }</p>

	Peak Data Rate If Delay Variation Required Delay Variation Tolerance If Media Inactivity Detection Required: NotificationRequested (Event ID = x, "Media Inactivity Detection(Media Inactivity Detection Time, Media Inactivity Detection Direction) ") (NOTE 1) If RTCP handling required: RTCP allocation If ECN transparent support required: ECN Enable = "True" Initiation Method = "inactive" If ECN Endpoint support required ECN Enable = "True" Initiation Method = "ECN Initiation Method" (NOTE 2) If notification of ECN Failure Report: NotificationRequested (Event ID = x, "ECN Failure")	
NOTE 1: The event parameters "Media Inactivity Detection Time" and "Media Inactivity Detection Direction" are optional. NOTE 2: This shall be set to a value other than "inactive". See Table 5.14.3.15.1.		

On reserving the termination, the IMS-AGW responds as in Table 5.17.2.2.2.

Table 5.17.2.2.2: Reserve AGW Connection Point Acknowledge

Address Information	Control information	Bearer information
Local Descriptor { Port IP Address IP Version }	Transaction ID = x Context ID = C1 Termination ID = T1 Stream Number	Local Descriptor { If media is "audio" or "video": Codec List RTP Payloads Rtpbw If RTCP bandwidth RtcpbwRS RtcpbwRR If IMS media plane security was provided in the request: Cryptographic SDES Attribute }

5.17.2.3 Configure AGW Connection Point

This procedure is used to configure the AGW connection point during session establishment or to reconfigure it during session establishment or after the session is established

The IMS-ALG sends a MODIFY request command as in Table 5.17.2.3.1.

Table 5.17.2.3.1: Configure AGW Connection Point Request

Address Information	Control information	Bearer information
If local resources are modified: Local Descriptor { Port IP Address IP Version } If remote resources are modified: Remote Descriptor { Port IP Address IP Version }	Transaction ID = x Context ID = C1 Termination ID = T1 If MPS priority is modified: Priority Indicator = x (NOTE 4) If Stream Number specified: Stream Number If Resources for multiple Codecs required: Reserve_Value If diffserv required:- Diffserv Code Point If tagging behaviour Diffserv Tagging Behaviour If Remote Source Address Filtering required:- Remote Source Address Filtering If Remote Source Address range required: Remote Source Address Mask If Remote Source Port Filtering required:- Remote Source Port Filtering If individual port: Remote Source Port If range of ports Remote Source Port Range NotificationRequested (Event ID = x, "termination heartbeat") If IP Realm specified:- IP Realm (NOTE 1) If Latching Required:- Latching If Sustainable Data Rate Policing Required:- Policing Required Sustainable Data Rate Maximum Burst Size If Peak Data Rate Policing Required: Policing Required Peak Data Rate If Delay Variation Required Delay Variation Tolerance If Media Inactivity Detection Required: NotificationRequested (Event ID = x, "Media Inactivity Detection(Media Inactivity Detection Time, Media Inactivity Detection Direction)") (NOTE 2) If RTCP handling required:	If local resources are modified: Local Descriptor { If media is "audio" or "video": Codec List RTP Payloads Rtpbw If RTCP bandwidth RtcpbwRS RtcpbwRR If IMS media plane security required: Cryptographic SDES Attribute } If remote resources are modified: Remote Descriptor { If media is "audio" or "video": Codec List RTP Payloads Rtpbw If RTCP bandwidth RtcpbwRS RtcpbwRR If IMS media plane security required: Cryptographic SDES Attribute }

	<p>RTCP allocation</p> <p>If ECN transparent support required: ECN Enable = "True" Initiation Method = "inactive"</p> <p>If ECN Endpoint support required ECN Enable = "True" Initiation Method = "ECN Initiation Method" (NOTE 3)</p> <p>If notification of ECN Failure Report: NotificationRequested (Event ID = x, "ECN Failure")</p>	
<p>NOTE 1: This can only be set to the same realm as at the reservation stage. If a different realm is specified, the IMS-AGW shall return error 501 "Not Implemented".</p> <p>NOTE 2: The event parameters "Media Inactivity Detection Time" and "Media Inactivity Detection Direction" are optional.</p> <p>NOTE 3: This shall be set to a value other than "inactive". See Table 5.14.3.15.1.</p> <p>NOTE 4: The support of the modification of the Priority Indicator value is optional for the IMS-AGW and depends on implementation solution for Priority call/session authorisation (see 3GPP TS 23.334 [23]).</p>		

The IMS-AGW responds as in Table 5.17.2.3.2.

Table 5.17.2.3.2: Configure AGW Connection Point Request Acknowledge

Address Information	Control information	Bearer information
<p>If local resources were provided in request: Local Descriptor { Port IP Address IP Version }</p> <p>If remote resources are provided in request: Remote Descriptor { Port IP Address IP Version } NOTE</p>	<p>Transaction ID = x Context ID = C1 Termination ID = T1</p> <p>If Stream Number Specified: Stream Number</p>	<p>If local resources were provided in request: Local Descriptor { If media is "audio" or "video": Codec List RTP Payloads Rtpbw If RTCP bandwidth RtcpbwRS RtcpbwRR If IMS media plane security was provided in request: Cryptographic SDES Attribute } If remote resources are provided in request: Remote Descriptor { If media is "audio" or "video": Codec List RTP Payloads Rtpbw If RTCP bandwidth RtcpbwRS RtcpbwRR If IMS media plane security was provided in the request: Cryptographic SDES Attribute } } NOTE</p>
<p>NOTE: Sending of the Remote Descriptor is optional.</p>		

5.17.2.4 Reserve and Configure AGW Connection Point

The IMS-ALG sends an ADD request command as in Table 5.17.2.4.1.

Table 5.17.2.4.1: Reserve and Configure AGW Connection Point Request

Address Information	Control information	Bearer information
Local Descriptor { Port = \$ IP Address = \$ IP Version = IPv4 or IPv6 } Remote Descriptor { Port IP Address IP Version }	Transaction ID = x If Context Requested: Context ID = \$ If Emergency Call: Emergency Call Indication If MPS call/session: Priority Indicator = x If Context Provided: Context ID = c1 Termination ID = \$ If Stream Number Specified: Stream Number If Resources for multiple Codecs shall be reserved: Reserve_Value If IP Interface Type: IP interface = "IP interface type" If indication on Bearer Released requested: NotificationRequested (Event ID = x, "BNC Release") If diffserv required:- Diffserv Code Point If tagging behaviour Diffserv Tagging Behaviour If Remote Source Address Filtering required:- Remote Source Address Filtering If Remote Source Address range required: Remote Source Address Mask If Remote Source Port Filtering required:- Remote Source Port Filtering If individual port: Remote Source Port If range of ports Remote Source Port Range NotificationRequested (Event ID = x, "termination heartbeat") If IP Realm specified:- IP Realm If Latching Required:- Latching If Sustainable Data Rate Policing Required:- Policing Required Sustainable Data Rate Maximum Burst Size If Peak Data Rate Policing Required:	Local Descriptor { If media is "audio" or "video": Codec List RTP Payloads Rtpbw If RTCP bandwidth RtcpbwRS RtcpbwRR If IMS media plane security required: Cryptographic SDES Attribute } Remote Descriptor { If media is "audio" or "video": Codec List RTP Payloads Rtpbw If RTCP bandwidth RtcpbwRS RtcpbwRR If IMS media plane security required: Cryptographic SDES Attribute } }

	<p>Policing Required Peak Data Rate If Delay Variation Required Delay Variation Tolerance</p> <p>If Media Inactivity Detection Required: NotificationRequested (Event ID = x, "Media Inactivity Detection(Media Inactivity Detection Time, Media Inactivity Detection Direction)") (NOTE 1)</p> <p>If RTCP handling required: RTCP allocation</p> <p>If ECN transparent support required: ECN Enable = "True" Initiation Method = "inactive"</p> <p>If ECN Endpoint support required ECN Enable = "True" Initiation Method = "ECN Initiation Method" (NOTE 2)</p> <p>If notification of ECN Failure Report: NotificationRequested (Event ID = x, "ECN Failure")</p>	
<p>NOTE 1: The event parameters "Media Inactivity Detection Time" and "Media Inactivity Detection Direction" are optional.</p> <p>NOTE 2: This shall be set to a value other than "inactive". See Table 5.14.3.15.1.</p>		

The IMS-A GW responds as in Table 5.17.2.4.2.

Table 5.17.2.4.2: Reserve and Configure AGW Connection Point Request Acknowledge

Address Information	Control information	Bearer information
Local Descriptor { Port IP Address IP Version } Remote Descriptor { Port IP Address IP Version } NOTE	Transaction ID = x Context ID = C1 Termination ID = T1 Stream Number	Local Descriptor { If media is "audio" or "video": Codec List RTP Payloads Rtpbw If RTCP bandwidth RtcpbwRS RtcpbwRR If IMS media plane security was provided in the request: Cryptographic SDES Attribute } Remote Descriptor { If media is "audio" or "video": Codec List RTP Payloads Rtpbw If RTCP bandwidth RtcpbwRS RtcpbwRR If IMS media plane security was provided in the request: Cryptographic SDES Attribute } } NOTE
NOTE: Sending of the Remote Descriptor is optional.		

5.17.2.5 Release AGW Termination

The IMS-ALG sends a SUBTRACT command as in Table 5.17.2.5.1.

Table 5.17.2.5.1: Release AGW Termination Request

Address Information	Control information	Bearer information
	Transaction ID = x Context ID= C1/ALL Termination ID = T1/ALL	

On releasing the termination, the IMS-A GW responds as in Table 5.17.2.5.2

Table 5.17.2.5.2: Release AGW Termination Request Acknowledge

Address Information	Control information	Bearer information
	Transaction ID = x Context ID = C1/ALL Termination ID = T1/ALL	

5.17.2.6 Termination Heartbeat Indication

When the procedure "Termination heartbeat indication" is required the following procedure is initiated: the IMS-A GW sends a NOT.req command with the following information.

5.17.2.6.1 NOT.req (Termination heartbeat)

Address Information	Control information	Bearer information
	Transaction ID = x Context ID = C1 Termination ID = T1 Event_ID (Event ID = x, "termination heartbeat")	

When the processing of command is complete, the IMS-ALG initiates the following procedure.

5.17.2.6.2 NOT.res p (Termination heartbeat)

Address Information	Control information	Bearer information
	Transaction ID = x Context ID = C1 Termination ID = T1	

The IMS-ALG shall correct any detected mismatch, by subtracting hanging terminations or clearing hanging contexts.

5.17.2.7 IP Bearer Released

When the procedure "IP Bearer Released" is required the following procedure is initiated: the IMS-A GW sends a NOT.req command with the following information.

5.17.2.7.1 NOT.req (IP Bearer Released)

Address Information	Control information	Bearer information
	Transaction ID = x Context ID = C1 Termination ID = T1 Event_ID (Event ID = x, "BNC Release (Cause)")	

When the processing of command is complete, the IMS-ALG initiates the following procedure.

5.17.2.7.2 NOT.res p (IP Bearer Released)

Address Information	Control information	Bearer information
	Transaction ID = x Context ID = C1 Termination ID = T1	

5.17.2.8 Media Inactivity Notification

When the procedure "Media Inactivity Notification" is required the following procedure is initiated: the IMS-A GW sends a NOT.req command with the following information.

5.17.2.8.1 NOT.req (Media Inactivity)

Address Information	Control information	Bearer information
	Transaction ID = x Context ID = C1 Termination ID = T1 Event_ID (Event ID = x, "Media Inactivity Detection")	

When the processing of command is complete, the IMS-ALG initiates the following procedure.

5.17.2.8.2 NOT.resp (Media Inactivity)

Address Information	Control information	Bearer information
	Transaction ID = x Context ID = C1 Termination ID = T1	

5.17.2.9 Change Through Connection

The IMS-ALG sends an ADD or a MODIFY request command as in Table 5.17.2.9.1.

5.17.2.9.1 Change Through Connection Request

Address Information	Control information	Bearer information
	Transaction ID = x If Context Requested: Context ID = \$ If Context Provided: Context ID = c1 If Termination Requested: Termination ID = \$ If Termination Provided: Termination ID = T1 Through-Connection = Connectivity Mode	

The IMS-AGW responds as in Table 5.17.2.9.2.

5.17.2.9.2 Change Through Connection Request Acknowledge

Address Information	Control information	Bearer information
	Transaction ID = x Context ID = C1 Termination ID = T1	

5.17.2.10 Change Flow Direction

The IMS-ALG sends an ADD or a MODIFY request command as in Table 5.17.2.10.1.

5.17.2.10.1 Change Flow Direction

Address Information	Control information	Bearer information
	Transaction ID = x If Context Requested: Context ID = \$ If Context Provided: Context ID = c1 If Termination Requested: Termination ID = \$ If Termination Provided: Termination ID = T1 Connection Configuration = (TerminationID= x1, TerminationID=x2, [type = x]),...	

The IMS-A GW responds as in Table 5.17.2.10.2.

5.17.2.10.2 Change Flow Direction Acknowledge

Address Information	Control information	Bearer information
	Transaction ID = x Context ID = C1 Termination ID = T1	

5.17.2.11 ECN Failure Indication

The IMS-A GW sends a NOTIFY request command as in Table 5.17.2.11.1.

Table 5.17.2.11.1: ECN Failure Indication

Address Information	Control information	Bearer information
	Transaction ID = x Context ID = C1 Termination ID = T1 Event_ID (Event ID = x, " ECN Failure (ECN Failure Type)")	

The IMS-ALG responds as in Table 5.17.2.11.2

Table 5.17.2.11.2: ECN Failure Indication Ack

Address Information	Control information	Bearer information
	Transaction ID = x Context ID = C1 Termination ID = T1	

5.17.3 Non-Call Related Procedures

5.17.3.1 General

This section describes the various non-call related procedures which are listed in Table 5.17.3.1.1

Table 5.17.3.1.1: IMS-AGW Non-Call Related Procedures

Transaction in 3GPP TS 23.334 [23]	Support	Comment
IMS-AGW Out of service	Mandatory	5.17.3.2
IMS-AGW Communication Up	Mandatory	5.17.3.3
IMS-AGW Restoration	Mandatory	5.17.3.4
IMS-AGW Register	Mandatory	5.17.3.5
IMS-AGW Re-register	Optional (NOTE 3)	5.17.3.6
IMS-ALG Ordered Re-register	Optional (NOTE 3)	5.17.3.7
IMS-ALG Restoration	Optional	5.17.3.8
IMS-ALG Out of Service	Optional	5.17.3.9
Audit Value	Optional (NOTE 3)	5.17.3.10
Command Rejected	Mandatory	The "Command Rejected" procedure may be used in response both to call-related and non-call-related ITU-T Recommendation H.248 Commands – 5.17.3.11
Capability Update	Optional	5.17.3.12
IMS-AGW Resource Congestion Handling – Activate	Optional	5.17.3.13
IMS-AGW Resource Congestion Handling – Indication	Optional	5.17.3.14
Inactivity timeout activation	Optional (NOTE 4)	5.17.3.15
Inactivity timeout indication	Optional (NOTE 4)	5.17.3.16
Realm Availability Change activation	Optional	5.17.3.17
Realm Availability Change indication	Optional	5.17.3.18
Termination Out of Service	Optional (NOTE 1)	5.17.3.19 (NOTE 2)
NOTE 1: Support of this procedure is mandatory in the IMS-ALG. NOTE 2: The "Termination Out-of-Service procedure" is also used as a call-related H.248 command NOTE 3: Support of this procedure is mandatory in the IMS-AGW. NOTE 4: Support of this procedure is mandatory in the IMS-AGW if UDP transport is supported.		

5.17.3.2 IMS-AGW Out Of Service

The IMS-AGW sends a SERVICE CHANGE request command as in Table 5.17.3.2.1.

Table 5.17.3.2.1: IMS-AGW Out Of Service Request

Address Information	Control information	Bearer information
	Transaction ID = x Context ID= - Termination ID = ROOT SC Method = FORCED or GRACEFUL SC Reason = 905 Termination Taken OOS or 908, MG Impending Failure, or 915 State Loss	

The IMS-ALG responds as in Table 5.17.3.2.2.

Table 5.17.3.2.2: IMS-AGW Out Of Service Request Ack

Address Information	Control information	Bearer information
	Transaction ID = x Context ID = - Termination ID = ROOT	

5.17.3.3 IMS-AGW Communication Up

The IMS-AGW sends a SERVICE CHANGE request command as in Table 5.17.3.3.1 to the IMS-ALG address to which the control link association was previously established.

Table 5.17.3.3.1: IMS-AGW Communication Up

Address Information	Control information	Bearer information
	Transaction ID = x Context ID = - Termination ID = ROOT SC Method = DISCONNECTED SC Reason = 900 , Service Restored	

The IMS-ALG may respond as in table 5.17.3.3.2. If a response is received, the control link association is re-established and the inactivity timer would be restarted.

Table 5.17.3.3.2: IMS-AGW Communication Up Ack

Address Information	Control information	Bearer information
	Transaction ID = x Context ID = - Termination ID = ROOT If required to register to a new IMS-ALG: Alternate MGC Id	

5.17.3.4 IMS-AGW Restoration

When the IMS-AGW has recovered, the IMS-AGW sends a SERVICE CHANGE as in Table 5.17.3.4.1,

Table 5.17.3.4.1: IMS-AGW Restoration

Address Information	Control information	Bearer information
	Transaction ID = x Context ID = - Termination ID = ROOT SC Method = RESTART SC Reason = 900, Service Restored	

The IMS-ALG responds as in Table 5.17.3.4.2.

Table 5.17.3.4.2: IMS-AGW Restoration Ack

Address Information	Control information	Bearer information
	Transaction ID = x Context ID = - Termination ID = ROOT If required to register to a new IMS-ALG: Alternate MGC Id	

5.17.3.5 IMS-AGW Register

The IMS-AGW sends a SERVICE CHANGE request command as in Table 5.17.3.5.1.

Table 5.17.3.5.1: IMS-AGW Register

Address Information	Control information	Bearer information
	Transaction ID = x Context ID = - Termination ID = ROOT SC Method = RESTART SC Reason = 901, Cold Boot or 902, Warm Boot H248 Profile Identity H248 Protocol Version	

The IMS-ALG responds as in Table 5.17.3.5.2.

Table 5.17.3.5.2: IMS-AGW Register Ack

Address Information	Control information	Bearer information
	Transaction ID = x Context ID = - Termination ID = ROOT If applicable (NOTE): H248 Protocol Version If applicable:- H248 Profile Identity If required to register to a new IMS- ALG: Alternate MGC Id	
NOTE: The IMS-ALG shall include the H.248 Protocol Version if the protocol version it supports or offers is lower than that proposed by the IMS-AGW. The IMS-ALG may include the H.248 Protocol Version if the protocol version it supports or offers is the protocol version proposed by the IMS-AGW.		

5.17.3.6 IMS-AGW Re-Register

The IMS-AGW sends a SERVICE CHANGE request command as in Table 5.17.3.6.1.

Table 5.17.3.6.1: IMS-AGW Re-Registration

Address Information	Control information	Bearer information
	Transaction ID = x Context ID = - Termination ID = ROOT SC Method = Handoff SC Reason = 903, MGC Directed Change H248 Profile Identity H248 Protocol Version	

The IMS-ALG responds as in Table 5.17.3.6.2.

Table 5.17.3.6.2: IMS-AGW Re-Registration Ack

Address Information	Control information	Bearer information
	Transaction ID = x Context ID = - Termination ID = ROOT If applicable (NOTE): H248 Protocol Version If applicable:- H248 Profile Identity If required to register to a new IMS-ALG: Alternate MGC Id	
NOTE: The IMS-ALG shall include the H.248 Protocol Version if the protocol version it supports or offers is lower than that proposed by the IMS-AGW. The IMS-ALG may include the H.248 Protocol Version if the protocol version it supports or offers is the protocol version proposed by the IMS-AGW.		

5.17.3.7 IMS-ALG Ordered Re-register

The IMS-ALG sends a SERVICE CHANGE request command as in Table 5.17.3.7.1.

Table 5.17.3.7.1: IMS-ALG Ordered Re-Register

Address Information	Control information	Bearer information
	Transaction ID = x Context ID = - Termination ID = ROOT SC Method = HANDOFF SC Reason = 903, MGC Directed Change Alternate MGC Id	

The IMS-AGW responds as in Table 5.17.3.7.2.

Table 5.17.3.7.2: IMS-ALG Ordered Re-Register Ack

Address Information	Control information	Bearer information
	Transaction ID = x Context ID = - Termination ID = ROOT	

The IMS-AGW then performs an IMS-AGW Re-Register procedure according to Clause 5.17.3.6.

5.17.3.8 IMS-ALG Restoration

When the IMS-ALG has recovered, the IMS-ALG sends a SERVICE CHANGE as in Table 5.17.3.8.1,

Table 5.17.3.8.1: IMS-ALG Restoration

Address Information	Control information	Bearer information
	Transaction ID = x Context ID = - Termination ID = ROOT SC Method = RESTART SC Reason = 901, Cold Boot OR 902, Warm Boot	

The IMS-AGW responds as in Table 5.17.3.8.2.

Table 5.17.3.8.2: IMS-ALG Restoration Ack

Address Information	Control information	Bearer information
	Transaction ID = x Context ID = - Termination ID = ROOT	

5.17.3.9 IMS-ALG Out of Service

The IMS-ALG sends a SERVICE CHANGE request command as in Table 5.17.3.9.1.

Table 5.17.3.9.1: IMS-ALG Out Of Service

Address Information	Control information	Bearer information
	Transaction ID = x Context ID = - Termination ID = ROOT SC Method = FORCED or GRACEFUL SC Reason = 905, Termination Taken OOS	

The IMS-AGW responds as in Table 5.17.3.9.2.

Table 5.17.3.9.2: IMS-ALG Out Of Service Ack

Address Information	Control information	Bearer information
	Transaction ID = x Context ID = - Termination ID = ROOT	

5.17.3.10 Audit Value

The IMS-ALG sends an AUDIT VALUE request command as in Table 5.17.3.10.1.

Table 5.17.3.10.1: Audit Value

Address Information	Control information	Bearer information
	Transaction ID = x Context ID= -/ALL/C1 Termination ID = ROOT/ALL/T1/PartialWildcard (NOTE 4, NOTE 5) Audit Packages (NOTE 1) Audit Descriptor = IndAuditParameter:= IndAudMediaDescriptor:= IndAudTerminationStateDescriptor:= serviceState Audit Descriptor = Empty (NOTE 2) Audit Descriptor = IndAuditParameter:= IndAudMediaDescriptor:= IndAudTerminationStateDescriptor:= Available Realms (NOTE 3) Audit Descriptor = IndAuditParameter:= IndAudMediaDescriptor:= IndAudTerminationStateDescriptor:= ROOT properties (NOTE 6)	
NOTE 1: Packages is for Null/Root Combination. NOTE 2: Used for control association monitoring. NOTE 3: Used for auditing available IP realms NOTE 4: The partial wildcard termination is used for the context audit (see table 5.17.3.10.3) and specifies the "group" part of the termination identity (e.g. "ip/5/*"). NOTE 5: Partial wildcard shall only be used when text encoding is used on the H.248 interface. NOTE 6: Used for auditing ROOT properties.		

The IMS-AGW responds as in Table 5.17.3.10.2.

Table 5.17.3.10.2: Audit Value Ack

Address Information	Control information	Bearer information
	Transaction ID = x Context ID = -/C1 Termination ID = ROOT/T1 Packages List serviceState Available Realms ROOT Properties	

Upon reception of the command in the IMS-AGW :

- The Service State returns the current Service State
- When Packages are requested, the Package Names and Versions are returned
- When realm availability is audited, the list of available realms is returned.
- When root properties are audited, the values of root properties are returned.

The following table illustrates the allowed combinations that can be obtained with the AuditValue Command:

Table 5.17.3.10.3: Combinations of AuditValue Command

ContextID	TerminationID	Information Obtained
Specific	Wildcard	Audit of matching Terminations in a Context
Specific	Specific	Audit of a single Termination in a Context
Null	Root	Audit of Media Gateway state and/or control association or available realms, or supported packages or ROOT properties.
All	Specific	(Non-null) ContextID in which the Termination currently exists
All	Partial Wildcard	(Non-null) ContextIDs in which the Terminations currently exist
NOTE: Partial wildcard shall only be used when text encoding is used on the H.248 interface.		

5.17.3.11 Command Rejected

When the procedure "Command Reject" is required the following procedure is initiated:

The IMS-AGW / IMS-ALG sends .a response to any command.req with the following information.

Table 5.17.3.11.1: ANYcommand.resp (command reject) IMS-AGW / IMS-ALG to IMS-ALG/ IMS-AGW

Address Information	Control information	Bearer information
	Transaction ID = z Context ID = c1 or no context Termination ID = T1 or no termination ID Reason=Error	

5.17.3.12 AGW Capability Change

The IMS-AGW sends a SERVICE CHANGE request command as in Table 5.17.3.12.1.

Table 5.17.3.12.1: AGW Capability Update

Address Information	Control information	Bearer information
	Transaction ID = x Context ID= - Termination ID = ROOT SC Method = RESTART SC Reason = 917, Capability Change H248 Profile Identity H248 Protocol Version	

The IMS-ALG responds as in table 5.17.3.12.2.

Table 5.17.3.12.2 AGW Capability Update Ack

Address Information	Control information	Bearer information
	Transaction ID = x Context ID = - Termination ID = ROOT	

5.17.3.13 IMS-AGW Resource Congestion Handling – Activate

The IMS-ALG sends a MODIFY request command as in Table 5.17.3.13.1

Table 5.17.3.13.1: IMS-AGW Resource Congestion Handling – Activate

Address Information	Control information	Bearer information
	Transaction ID = x Context ID = - Termination ID = ROOT NotificationRequested (Event ID = x, "Overload Notification")	

The IMS-AGW responds as in Table 5.17.3.13.2.

Table 5.17.3.13.2: IMS-AGW Resource Congestion Handling – Activate Ack

Address Information	Control information	Bearer information
	Transaction ID = x Context ID = - Termination ID = ROOT	

5.17.3.14 IMS-AGW Resource Congestion Handling – Indication

The IMS-AGW sends a NOTIFY request command as in Table 5.17.3.14.1

Table 5.17.3.14.1: IMS-AGW Resource Congestion Handling – Indication

Address Information	Control information	Bearer information
	Transaction ID = x Context ID = - Termination ID = ROOT If H.248.11 used: Event_ID (Event ID = x, "Overload Notification") If H.248.10 used: Event_ID (Event ID = x, "Overload Notification (Reduction)")	

The IMS-ALG responds as in Table 5.17.3.14.2

Table 5.17.3.14.2: IMS-AGW Resource Congestion Handling – Indication Ack

Address Information	Control information	Bearer information
	Transaction ID = x Context ID = - Termination ID = ROOT	

5.17.3.15 Inactivity Timeout – Activation

The IMS-ALG sends a MODIFY request command as in Table 5.17.3.15.1

Table 5.17.3.15.1: Inactivity Timeout – Activation

Address Information	Control information	Bearer information
	Transaction ID = x Context ID = NULL Termination ID = ROOT NotificationRequested (Event ID = x, "Inactivity Timeout")	

The IMS-A GW responds as in Table 5.17.3.15.2.

Table 5.17.3.15.2: Inactivity Timeout – Activation Ack

Address Information	Control information	Bearer information
	Transaction ID = x Context ID = NULL Termination ID = ROOT	

5.17.3.16 Inactivity Timeout – Indication

The IMS-A GW sends a NOTIFY request command as in Table 5.17.3.16.1.

Table 5.17.3.16.1: Inactivity Timeout – Indication

Address Information	Control information	Bearer information
	Transaction ID = x Context ID = NULL Termination ID = ROOT Event_ID (Event ID = x, "Inactivity Timeout")	

The IMS-ALG responds as in Table 5.17.3.16.2

Table 5.17.3.16.2: Inactivity Timeout – Indication Ack

Address Information	Control information	Bearer information
	Transaction ID = x Context ID = NULL Termination ID = ROOT	

5.17.3.17 Realm Availability Change – Activation

The IMS-ALG sends a MODIFY request command as in Table 5.17.3.17.1.

Table 5.17.3.17.1: Realm Availability Change – Activation

Address Information	Control information	Bearer information
	Transaction ID = x Context ID = - Termination ID = ROOT NotificationRequested (Event ID = x, "Realm Availability Change")	

The IMS-A GW responds as in Table 5.17.3.17.2.

Table 5.17.3.17.2: Realm Availability Change – Activation Ack

Address Information	Control information	Bearer information
	Transaction ID = x Context ID = - Termination ID = ROOT	

5.17.3.18 Realm Availability Change – Indication

The IMS-A GW sends a NOTIFY request command as in Table 5.17.3.18.1.

Table 5.17.3.18.1: Realm Availability Change – Indication

Address Information	Control information	Bearer information
	Transaction ID = x Context ID = - Termination ID = ROOT Event_ID (Event ID = x, "Realm Availability Change (Changed Realms)")	
NOTE: The ObservedEvent Parameters returned within the Changed Realms are defined as mandatory since it shall contain at minimum 1 parameter but may contain both Newly Available Realms and Newly Unavailable Realms.		

The IMS-ALG responds as in Table 5.17.3.18.2

Table 5.17.3.18.2: Realm Availability Change – Indication Ack

Address Information	Control information	Bearer information
	Transaction ID = x Context ID = - Termination ID = ROOT	

5.17.3.19 Termination Out Of Service

This procedure only applies when text encoding is used on the H.248 interface.

The IMS-A GW sends a SERVICE CHANGE request command as in Table 5.17.3.19.1.

Table 5.17.3.19.1: Termination Out Of Service Request

Address Information	Control information	Bearer information
	Transaction ID = x Context ID = C1/ALL Termination ID = T1 or Wildcarded Termination (NOTE) SC Method = FORCED SC Reason = 904 ("Termination Malfunction") or 905 ("Termination Taken OOS") or 906 ("Loss of Lower Layer Connectivity"), or 907 ("Transmission Failure") or 910 ("Media Capability Failure")	
NOTE: This is set to a specific termination identity or a partially wildcarded identity (i.e. specifying the "interface" part of the termination ID and wildcarding the "group" and "Id" parts) or a wholly wildcarded identity (i.e. ip/*).		

The IMS-ALG responds as in Table 5.17.3.19.2.

Table 5.17.3.19.2: Termination Out Of Service Request Ack

Address Information	Control information	Bearer information
	Transaction ID = x Context ID = C1/ALL Termination ID = As received	

Annex A (informative): Change history

Change history							
Date	TSG #	TSG Doc.	CR	Rev	Subject/Comment	Old	New
2009-12	CT#46	CP-090823			3GPP TS Presented for information and approval in CT#46	1.0.0	9.0.0
2010-03	CT#47	CP-100050	0001	2	IMS media plane security stage 3	9.0.0	9.1.0
		CP-100044	0002	1	Non-call Related Procedures Naming update		
		CP-100044	0006	1	Correction to table notes and references		
		CP-100044	0007	1	Termination Type Alignment		
		CP-100044	0008		Returned SDP Properties		
		CP-100044	0009	1	Manipulating and Auditing Context Attributes		
		CP-100044	0010	1	Inactivity Timeout		
		CP-100044	0011	1	Clean-up Proposals		
2010-06	CT#48	CP-100289	0012	1	Transport protocol to be indicated to gateway for end-to-end media security	9.1.0	9.2.0
			0015		Profiling of SDES crypto attribute for e2a media security		
		CP-100284	0013	1	Handling of Stream mode		
2010-09	CT#49	CP-100461	0016		Procedures for Emergency indicator	9.2.0	9.3.0
		CP-100461	0017	1	Error Descriptor		
2011-03	CT#51	CP-110278	0019	10	ECN Support in Iq Interface	9.3.0	10.0.0
2011-06	CT#52	CP-110368	0021	1	Alignment of 3GPP profiles with SG16 ECN package definition	10.0.0	10.1.0
2011-09	CT#53	CP-110573	0022	1	Transcoding at ATCF/ATGW during eSRVCC	10.1.0	10.2.0
2011-12	CT#54	CP-110798	0023	1	Explicit Congestion Notification	10.2.0	10.3.0
		CP-110796	0024	1	Update of reference to H.248.52		
2012-06	CT#56	CP-120226	0025	1	Reference update: draft-ietf-avtcore-ecn-for-rtp	10.3.0	10.4.0
2012-09	CT#57	CP-120478	0026	3	Support of Multimedia Priority Service (MPS) over Iq Interface – Stage 3	10.4.0	11.0.0
2012-12	CT#58	CP-120723	0036	-	Iq interface updates of ECN Support Package	11.0.0	11.1.0
		CP-120734	0037	3	Support of Multimedia Priority Service (MPS) in Modify over Iq Interface – Stage 3		
2013-06	CT#60	CP-130294	0039	2	ECN relying reference change	11.1.0	11.2.0