

3GPP TS 29.292 V11.6.0 (2013-06)

Technical Specification

3rd Generation Partnership Project; Technical Specification Group Core network and Terminals; Interworking between the IP Multimedia (IM) Core Network (CN) Subsystem (IMS) and MSC Server for IMS Centralized Services (ICS) (Release 11)



The present document has been developed within the 3rd Generation Partnership Project (3GPPTM) and may be further elaborated for the purposes of 3GPP.

The present document has not been subject to any approval process by the 3GPP Organizational Partners and shall not be implemented. This Specification is provided for future development work within 3GPP only. The Organizational Partners accept no liability for any use of this Specification. Specifications and reports for implementation of the 3GPPTM system should be obtained via the 3GPP Organizational Partners' Publications Offices.

Keywords

GSM, LTE, UMTS, IP, multimedia, telephony,
supplementary services

3GPP

Postal address

3GPP support office address

650 Route des Lucioles - Sophia Antipolis
Valbonne - FRANCE
Tel.: +33 4 92 94 42 00 Fax: +33 4 93 65 47 16

Internet

<http://www.3gpp.org>

Copyright Notification

No part may be reproduced except as authorized by written permission.
The copyright and the foregoing restriction extend to reproduction in all media.

© 2013, 3GPP Organizational Partners (ARIB, ATIS, CCSA, ETSI, TTA, TTC).
All rights reserved.

UMTS™ is a Trade Mark of ETSI registered for the benefit of its members
3GPP™ is a Trade Mark of ETSI registered for the benefit of its Members and of the 3GPP Organizational Partners
LTE™ is a Trade Mark of ETSI currently being registered for the benefit of its Members and of the 3GPP Organizational Partners
GSM® and the GSM logo are registered and owned by the GSM Association

Contents

Foreword	7
1 Scope	8
2 References.....	8
3 Definitions and abbreviations	10
3.1 Definitions	10
3.2 Abbreviations	11
4 Interworking overview	11
4.1 Interworking reference model	11
4.2 Interworking reference points and interfaces.....	12
4.3 Interworking functional entities	12
4.3.1 MSC Server enhanced for ICS.....	12
4.3.2 Circuit Switched Media Gateway Function (CS-MGW)	12
4.4 Control plane interworking	12
4.5 User plane interworking	13
5 Control plane procedures and interworking.....	13
5.1 General	13
5.2 IMS registration procedures interworking	14
5.2.1 Initial registration	14
5.2.2 Reregistration.....	14
5.2.3 MSC Server initiated deregistration.....	14
5.3 Interworking of mobile originating call setup from NAS signalling to SIP	14
5.3.1 General	14
5.3.2 Receipt of a setup message.....	14
5.3.3 Sending of INVITE.....	15
5.3.3.1 General.....	15
5.3.3.2 Coding of INVITE	15
5.3.3.3 Coding of the SDP offer	16
5.3.3.4 Actions on the SDP answer	16
5.3.4 Sending of ALERTING	16
5.3.4a Sending of PROGRESS	16
5.3.4b Through-Connecting early media from IMS	16
5.3.5 Applying ringback tone.....	17
5.3.6 Receipt of 200 OK (INVITE)	17
5.3.7 Receipt of status-codes 3xx	17
5.3.8 Receipt of SIP status-codes 4xx, 5xx or 6xx	17
5.3.9 Receipt of DISCONNECT	19
5.3.10 Restoration procedures.....	19
5.4 Interworking of mobile terminating call setup from SIP to NAS signalling.....	20
5.4.1 General.....	20
5.4.2 Receipt of initial INVITE	20
5.4.3 Sending of SETUP	21
5.4.4 Receipt of CALL CONFIRMED	22
5.4.5 Bearer establishment.....	22
5.4.5.1 Network side bearer establishment	22
5.4.5.2 Access bearer assignment.....	22
5.4.5.3 Transcoding	23
5.4.6 Receipt of ALERTING	23
5.4.7 Applying early media	23
5.4.8 Call rejection or abandonment	23
5.4.8.1 Receipt of RELEASE COMPLETE or DISCONNECT	23
5.4.8.2 Receipt of CANCEL or BYE.....	25
5.4.9 Receipt of CONNECT	25
5.4.10 Call failure procedures	25
5.5 Interworking of established call clearing between NAS signalling and SIP	26

5.5.1	General	26
5.5.2	Clearing initiated by the mobile	26
5.5.3	Clearing initiated by the IM CN subsystem	26
5.5.4	Autonomous clearing initiated by the MSC Server	26
5.6	Supplementary Services invocation	26
5.6.1	Originating identification presentation/restriction (OIP/OIR)	26
5.6.2	Terminating identification presentation/restriction (TIP/TIR)	26
5.6.2.1	Terminating identification presentation (TIP)	26
5.6.2.2	Terminating identification restriction (TIR)	27
5.6.3	Communication Hold (HOLD)	27
5.6.3.1	HOLD initiated via NAS signalling	27
5.6.3.1.1	Hold	27
5.6.3.1.2	Resume	28
5.6.3.2	HOLD initiated via SIP signalling	28
5.6.3.2.1	Hold	28
5.6.3.2.2	Resume	28
5.6.4	Communication Waiting (CW)	28
5.6.4.1	Receipt of initial INVITE	28
5.6.4.2	Accepting the waiting call	29
5.6.4.3	Rejecting the waiting call	29
5.6.4.4	Communication release during waiting condition	30
5.6.4.5	CW condition timeout	30
5.6.4.6	Notification to originator	30
5.6.5	Communication Barring (CB)	30
5.6.6	Communication Diversion	31
5.6.6.1	General	31
5.6.6.2	CDIV invocation	31
5.6.6.2.1	Communication Forwarding Unconditional (CFU)	31
5.6.6.2.2	Communication Forwarding Busy (CFB)	31
5.6.6.2.3	Communication Forwarding No Reply (CFNR)	31
5.6.6.2.4	Communication Forwarding on Not Logged-In (CFNL)	31
5.6.6.2.5	Communication Deflection (CD)	31
5.6.6.2.6	Communication Forwarding on Subscriber Not Reachable (CFNRc)	32
5.6.6.3	Notifications relating to CDIV	32
5.6.6.3.1	Communication Diversion Notification (CDIVN)	32
5.6.6.3.2	Notification to an originating user on CS access	32
5.6.6.3.3	Notification to a terminating user on CS access	33
5.6.7	Explicit Communication Transfer (ECT)	33
5.6.7.1	General	33
5.6.7.2	MSC Server as transferor on behalf of UE	33
5.6.7.3	MSC Server as transferee on behalf of UE	34
5.6.7.3.1	Actions without 3PCC	34
5.6.7.3.2	Actions with 3PCC	34
5.6.7.4	MSC Server as transfer target on behalf of UE	34
5.6.8	Conference (CONF)	35
5.6.8.1	General	35
5.6.8.2	MSC Server as conference creator	35
5.6.8.2.1	Conference creation	35
5.6.8.2.2	Putting the conference on hold	35
5.6.8.2.3	Resuming a held conference	35
5.6.8.2.4	Adding a party to the conference	36
5.6.8.2.5	Terminating the conference or disconnecting a party from the conference	36
5.6.8.2.6	Receipt of a SplitMPTY message	36
5.6.8.3	MSC Server as conference participant	36
5.6.8.3.1	Receipt of invitation to conference	36
5.6.8.3.1.1	General	36
5.6.8.3.1.2	Receipt of REFER within a dialog	36
5.6.8.3.1.3	Receipt of REFER outside a dialog	37
5.6.8.3.1.4	Receipt of INVITE	37
5.6.8.3.2	Notification of conference invocation	37
5.6.9	Customized Alerting Tones (CAT)	37
5.6.9.1	General	37

5.6.9.2	Early session model.....	38
5.6.9.2.1	Originating request.....	38
5.6.9.3	Forking model.....	38
5.6.9.4	Gateway model.....	38
5.6.10	Communication Completion Services (CCBS/CCNL/CCNR).....	38
5.6.10.1	General.....	38
5.6.10.2	Communication Completion Terminated at Served User.....	38
5.6.10.3	Communication Completion Originated at Served User.....	38
5.6.10.3.1	Actions without 3PCC.....	38
5.6.10.3.2	Actions with 3PCC.....	38
5.7	Supplementary Service Configuration.....	39
5.7.1	General.....	39
5.7.2	Receipt of REGISTER message.....	39
5.7.3	Receipt of HTTP response.....	39
5.7.4	Service data interworking.....	39
5.7.4.1	Originating identification presentation/restriction (OIP/OIR).....	39
5.7.4.1.1	Registration/erasure.....	39
5.7.4.1.2	Activation/deactivation.....	40
5.7.4.1.3	Interrogation.....	40
5.7.4.2	Terminating identification presentation/restriction (TIP/TIR).....	40
5.7.4.2.1	Registration/erasure.....	40
5.7.4.2.2	Activation/deactivation.....	40
5.7.4.2.3	Interrogation.....	40
5.7.4.3	Communication Hold (HOLD).....	41
5.7.4.4	Communication Waiting (CW).....	41
5.7.4.4.1	Registration/erasure.....	41
5.7.4.4.2	Activation/deactivation.....	41
5.7.4.4.3	Interrogation.....	41
5.7.4.5	Communication Barring (CB).....	42
5.7.4.5.1	Registration/erasure.....	42
5.7.4.5.2	Activation/deactivation.....	42
5.7.4.5.3	Interrogation.....	42
5.7.4.6	Communication Diversion (CDIV).....	42
5.7.4.6.1	Registration.....	42
5.7.4.6.1a	Erasure.....	43
5.7.4.6.2	Activation/deactivation.....	44
5.7.4.6.3	Interrogation.....	44
5.7.4.7	Explicit Communication Transfer (ECT).....	45
5.7.4.8	Conference (CONF).....	45
5.7.4.9	Communication Completion Services (CCBS/CCNL/CCNR).....	45
5.7.4.9.1	Activation/deactivation.....	45
5.7.4.9.2	Interrogation.....	45
5.8	Handover / Relocation.....	46
5.8.1	Intra-MSC Handover/Relocation.....	46
5.8.2	Inter-MSC Handover/Relocation.....	46
6	User plane interworking.....	46
6.1	General.....	46
6.2	IuCS to Mb interworking.....	46
6.2.1	Interworking with transcoding.....	46
6.2.2	Transcoder-less interworking.....	47
6.3	TDM-based A-interface to Mb interworking.....	47
6.3.1	Interworking with transcoding.....	47
6.3.2	Transcoder-less interworking.....	48
6.4	IP-based A-interface to Mb interworking.....	48
6.4.1	Interworking with transcoding.....	48
6.4.2	Transcoder-less interworking.....	49
7	MSC Server – CS-MGW interaction.....	50
7.1	Mobile originated call.....	50
7.1.1	CS-MGW selection.....	50
7.1.2	IMS session side establishment.....	50

7.1.3	Access bearer establishment.....	50
7.1.3.1	General.....	50
7.1.3.2	Iu interface on IP.....	50
7.1.3.3	A interface over IP.....	50
7.1.3.4	A interface over TDM.....	50
7.1.3.5	Iu over UTRAN and GERAN.....	50
7.1.4	Apply ringing tone.....	51
7.1.5	Through connection.....	51
7.1.5a	Handling of Forking.....	51
7.1.6	Failure handling in MSC server.....	51
7.2	Mobile terminated call.....	51
7.2.1	CS-MGW selection.....	51
7.2.2	Network side session establishment.....	51
7.2.3	Access bearer assignment.....	52
7.2.3.1	General.....	52
7.2.3.2	Iu interface on IP.....	52
7.2.3.3	A interface over IP.....	52
7.2.3.4	A interface over TDM.....	52
7.2.3.5	Iu over UTRAN and GERAN.....	52
7.2.4	Apply ringing tone.....	52
7.2.5	Through connection.....	52
7.2.6	Announcement.....	52
7.2.7	Failure handling in the MSC server.....	53
7.3	Call clearing.....	53
7.3.1	Clearing received from the network.....	53
7.3.1.1	Access bearer clearing.....	53
7.3.1.2	Network side clearing.....	53
7.3.2	Clearing received from the user.....	53
7.3.2.1	Access bearer clearing.....	53
7.3.2.2	Network side clearing.....	53
7.3.3	Call clearing received from the CS-MGW.....	53
7.3.3.1	Bearer released received on the access side.....	53
7.3.3.2	Bearer released received on the network side.....	53
7.4	Call independent procedures.....	54
7.5	Explicit Congestion Notification.....	54
7.6	Multimedia Priority Service (MPS) Support.....	54
Annex A (informative):	Change history.....	55

Foreword

This Technical Specification has been produced by the 3rd Generation Partnership Project (3GPP).

The contents of the present document are subject to continuing work within the TSG and may change following formal TSG approval. Should the TSG modify the contents of the present document, it will be re-released by the TSG with an identifying change of release date and an increase in version number as follows:

Version x.y.z

where:

- x the first digit:
 - 1 presented to TSG for information;
 - 2 presented to TSG for approval;
 - 3 or greater indicates TSG approved document under change control.
- y the second digit is incremented for all changes of substance, i.e. technical enhancements, corrections, updates, etc.
- z the third digit is incremented when editorial only changes have been incorporated in the document.

1 Scope

IMS Centralized Services (ICS) enable the delivery of IM CN subsystem based multimedia telephony and supplementary services as defined in 3GPP TS 24.173 [4] to users regardless of the attached access network type; e.g. CS domain access or IP-CAN.

The present document specifies the principles of interworking between the IM CN subsystem and CS domain in order to enable ICS for UEs using CS domain access.

The present document addresses the area of registration procedures interworking between the CS domain and IM CN subsystem.

The present document addresses the areas of control and user plane interworking between the IM CN subsystem and CS domain through an MSC Server enhanced for ICS and CS-MGW respectively. This includes the signalling procedures between the MSC Server and CS-MGW. For the specification of control plane interworking, present document defines the protocol interworking between the 3GPP profile of SIP as described in 3GPP TS 24.229 [2] and NAS signalling as described in 3GPP TS 24.008 [3] required for the support of IM CN subsystem based multimedia telephony and supplementary services.

The present document addresses the area of supplementary service configuration interworking between the CS domain and IM CN subsystem.

The present document is applicable to the MSC Server and CS-MGW.

2 References

The following documents contain provisions which, through reference in this text, constitute provisions of the present document.

- References are either specific (identified by date of publication, edition number, version number, etc.) or non-specific.
- For a specific reference, subsequent revisions do not apply.
- For a non-specific reference, the latest version applies. In the case of a reference to a 3GPP document (including a GSM document), a non-specific reference implicitly refers to the latest version of that document *in the same Release as the present document*.

- [1] 3GPP TR 21.905: "Vocabulary for 3GPP Specifications".
- [2] 3GPP TS 24.229: "IP Multimedia Call Control Protocol based on SIP and SDP".
- [3] 3GPP TS 24.008: "Mobile radio interface layer 3 specification; Core Network protocols; Stage 3".
- [4] 3GPP TS 24.173: "IMS multimedia telephony communication service and supplementary services; Stage 3".
- [5] 3GPP TS 23.292: "IP Multimedia Subsystem (IMS) Centralized Services; Stage 2".
- [6] 3GPP TS 23.002: "Network Architecture".
- [7] 3GPP TS 24.292: "IP Multimedia (IM) Core Network (CN) subsystem Centralized Services (ICS); Stage 3".
- [8] 3GPP TS 23.018: "Basic call handling; Technical realization".
- [9] 3GPP TS 22.003: "Circuit Teleservices supported by a Public Land Mobile Network (PLMN)".
- [10] 3GPP TS 23.003: "Numbering, addressing and identification".
- [11] 3GPP TS 29.232: "Media Gateway Controller (MGC) – Media Gateway (MGW) interface; Stage 3".

- [12] 3GPP TS 24.081: "Line Identification Supplementary Services – Stage 3".
- [13] Void
- [14] 3GPP TS 24.608: "Terminating Identification Presentation (TIP) and Terminating Identification Restriction (TIR) using IP Multimedia (IM) Core Network (CN) subsystem; Protocol specification".
- [15] 3GPP TS 25.414: "UTRAN Iu interface data transport and transport signalling".
- [16] 3GPP TS 25.415: "UTRAN Iu interface user plane protocols".
- [17] 3GPP TS 25.411: "UTRAN Iu interface layer 1".
- [18] 3GPP TS 29.414: "Core network Nb data transport and transport signalling".
- [19] 3GPP TS 48.004: "Base Station System – Mobile-services Switching Centre (BSS – MSC) interface; Layer 1 specification".
- [20] 3GPP TS 29.002: "Mobile Application Part (MAP) specification".
- [21] 3GPP TS 26.235: "Packet switched conversational multimedia applications; Default codecs".
- [22] 3GPP TS 26.226: "CTM Cellular Text telephony Modem, General description".
- [23] 3GPP TS 24.604: "Communication Diversion (CDIV) using IP Multimedia (IM) Core Network (CN) subsystem; Protocol specification".
- [24] 3GPP TS 24.082: "Call Forwarding (CF) supplementary services; Stage 3".
- [25] 3GPP TS 24.072: "Call Deflection (CD) Supplementary Service; Stage 3".
- [26] 3GPP TS 24.083: "Call Waiting (CS) and Call Hold (HOLD) supplementary services; Stage 3".
- [27] 3GPP TS 24.610: "Communication HOLD (HOLD) using IP Multimedia (IM) Core Network (CN) subsystem; Protocol specification".
- [28] 3GPP TS 26.114: "IP Multimedia Subsystem (IMS); Multimedia Telephony; Media handling and interaction".
- [29] 3GPP TS 24.080: "Mobile radio interface layer 3 supplementary services specification; Formats and coding".
- [30] 3GPP TS 24.088: "Call Barring (CB) Supplementary Service – Stage 3".
- [31] 3GPP TS 24.611: "Anonymous Communication Rejection (ACR) and Communication Barring (CB); using IP Multimedia (IM) Core Network (CN) subsystem; Protocol specification".
- [32] 3GPP TS 24.091: "Explicit Call Transfer (ECT) supplementary service; Stage 3".
- [33] 3GPP TS 24.629: "Explicit Communication Transfer (ECT) using IP Multimedia (IM) Core Network (CN) subsystem; Protocol specification".
- [34] 3GPP TS 24.084: "Multi Party (MPTY) supplementary service – Stage 3".
- [35] 3GPP TS 24.605: "Conference (CONF) using IP Multimedia (IM) Core Network (CN) subsystem; Protocol specification".
- [36] 3GPP TS 24.147: "Conferencing using the IP Multimedia (IM) Core Network (CN) subsystem; Stage 3".
- [37] 3GPP TS 23.009: "Handover procedures".
- [38] 3GPP TS 48.103: "Base Station System – Media GateWay (BSS-MGW) interface; User Plane transport mechanism".
- [39] 3GPP TS 23.205: "Bearer Independent switched core network; Stage 2".

- [40] 3GPP TS 23.231: "SIP-I based circuit-switched core network; Stage 2".
- [41] 3GPP TS 24.010: "Mobile radio interface layer 3 Supplementary services specification; General aspects".
- [42] 3GPP TS 24.623: "Extensible Markup Language (XML) Configuration Access Protocol (XCAP) over the Ut interface for Manipulating Supplementary Services".
- [43] 3GPP TS 24.607: "Originating Identification Presentation (OIP) and Originating Identification Restriction (OIR) using IP Multimedia (IM) Core Network (CN) subsystem; Protocol specification".
- [44] 3GPP TS 24.615: "Communication Waiting (CW) using IP Multimedia (IM) Core Network (CN) subsystem; Protocol specification".
- [45] IETF RFC 3326: "The Reason Header Field for the Session Initiation Protocol (SIP)".
- [46] 3GPP TS 29.163: "Interworking between the IP Multimedia (IM) Core Network (CN) subsystem and Circuit Switched (CS) networks".
- [47] IETF RFC 5009: "Private Header (P-Header) Extension to the Session Initiation Protocol (SIP) for Authorization of Early Media".
- [48] IETF RFC 3168: "The Addition of Explicit Congestion Notification (ECN) to IP".
- [49] IETF RFC 6679: "Explicit Congestion Notification (ECN) for RTP over UDP".
- [50] IETF RFC 3959: "The Early Session Disposition Type for the Session Initiation Protocol (SIP)".
- [51] 3GPP TS 24.182: "IP Multimedia Subsystem (IMS) Customized Alerting Tones (CAT); Protocol specification".
- [52] 3GPP TS 24.642: "Completion of Communications to Busy Subscriber (CCBS) and Completion of Communications by No Reply (CCNR) using IP Multimedia (IM) Core Network (CN) subsystem".
- [53] 3GPP TS 24.093: "Completion of Calls to Busy Subscriber (CCBS); Stage 3".
- [54] 3GPP TS 32.260: "Telecommunication management; Charging management; IP Multimedia Subsystem (IMS) charging".
- [54] 3GPP TS 22.153: "Multimedia Priority Service".
- [55] IETF RFC 4458: "Session Initiation Protocol (SIP) URIs for Applications such as Voicemail and Interactive Voice Response (IVR)".

3 Definitions and abbreviations

3.1 Definitions

For the purposes of the present document, the terms and definitions given in 3GPP TR 21.905 [1] and the following apply. A term defined in the present document takes precedence over the definition of the same term, if any, in 3GPP TR 21.905 [1].

NAS signalling: layer 3 signalling carried over CS domain access between the UE and MSC Server as defined in 3GPP TS 24.008 [3].

For the purposes of the present document, the following terms and definitions given in 3GPP TS 24.629 [33] apply:

transferee
transferor
transfer target

3.2 Abbreviations

For the purposes of the present document, the abbreviations given in 3GPP TR 21.905 [1] and the following apply. An abbreviation defined in the present document takes precedence over the definition of the same abbreviation, if any, in 3GPP TR 21.905 [1].

3PCC	3 rd Party Call Control
ACR	Anonymous Communication Rejection
CB	Communication Barring
CCBS	Completion of Communication to Busy Subscriber
CCNL	Completion of Communications on Not Logged-in
CCNR	Completion of Communications on No Reply
CD	Communication Deflection
CDIV	Communication DIVersion
CDIVN	Communication DIVersion Notification
CFNL	Communication Forwarding on Not Logged-in
CFNR	Communication Forwarding No Reply
CFNRc	Communication Forwarding on subscriber Not Reachable
CFU	Communication Forwarding Unconditional
CONF	CONFerence
CS	Circuit Switched
CS-MGW	Circuit Switched Media Gateway
ECN	Explicit Congestion Notification
ECT	Explicit Communication Transfer
GRUU	Globally Routable User Agent URI
HOLD	communication HOLD
ICB	Incoming Communication Barring
ICS	IM CN subsystem Centralized Services
IMS-MGW	IP Multimedia Subsystem-Media Gateway Function
IuFP	Iu Framing Protocol
MboIP	Mb over IP
MRFP	Media Resource Function Processor
MPS	Multimedia Priority Service
NAS	Non Access Stratum
OCB	Outgoing Communication Barring
OIP	Originating Identification Presentation
OIR	Originating Identification Restriction
RTCP	RTP Control Protocol
TDM	Time Division Multiplex
TIP	Terminating Identification Presentation
TIR	Terminating Identification Restriction

4 Interworking overview

4.1 Interworking reference model

Figure 4.1.1 details the reference model required to support interworking between the 3GPP IM CN subsystem and CS domain access for IM basic voice calls and supplementary services.

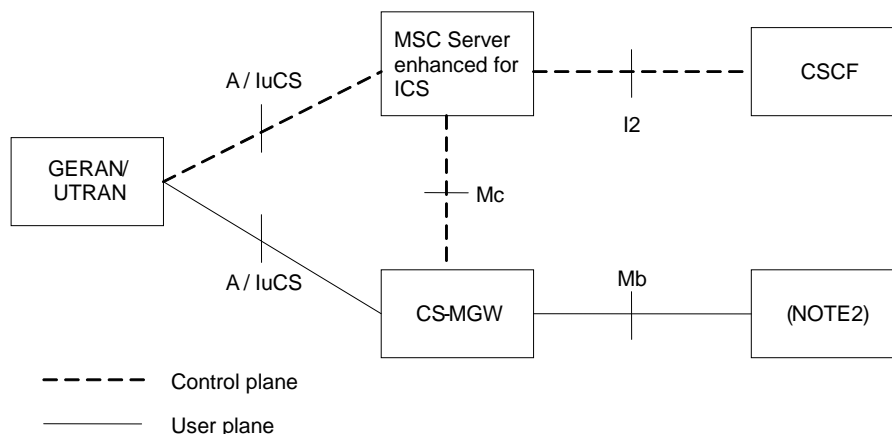

- NOTE 1: The logical split of the signalling and bearer path between the CS access network and MSC Server enhanced for ICS is as shown; however, the signalling and bearer may be directly connected to the MGW.
- NOTE 2: The CS-MGW may be connected via the Mb reference point to various network entities, such as a UE (via a GTP tunnel to a GGSN), an MRFP, or an IMS-MGW, or a remote CS-MGW.

Figure 4.1.1: MSC Server – IM CN subsystem interworking reference model

4.2 Interworking reference points and interfaces

The reference points and network interfaces shown in figure 4.1.1 are as described:

A reference point: The A reference point is defined in 3GPP TS 23.002 [6].

IuCS reference point: The IuCS reference point is defined in 3GPP TS 23.002 [6].

I2 reference point: The call control protocol specified in this document for use on the I2 reference point (i.e. between MSC Server enhanced for ICS and CSCF) is based on Mw reference point as defined in 3GPP TS 23.002 [6] and the 3GPP profile of SIP as defined in accordance with 3GPP TS 24.229 [2].

Mc reference point: The Mc reference point is defined in 3GPP TS 23.002 [6].

Mb reference point: The Mb reference point is defined 3GPP TS 23.002 [6].

4.3 Interworking functional entities

4.3.1 MSC Server enhanced for ICS

This is the component which provides the interworking between CS domain access and IM CN subsystem control planes, and it shall support the functions as defined in accordance with 3GPP TS 23.002 [6].

For brevity, where the term "MSC Server" is used in the rest of the specification, this shall be understood as "MSC Server enhanced for ICS".

4.3.2 Circuit Switched Media Gateway Function (CS-MGW)

This is the component which provides the interworking between CS domain access and IM CN subsystem user planes, and it shall support the functions as defined in accordance with 3GPP TS 23.002 [6].

4.4 Control plane interworking

Within the IM CN subsystem, the 3GPP profile of SIP defined in 3GPP TS 24.229 [2] is used for session control.

Over CS domain access, NAS signalling is used for call origination, call termination and supplementary services .

Therefore, in order to provide the required interworking to enable ICS for UE using CS domain access, the control plane protocols shall be interworked within the MSC Server.

4.5 User plane interworking

Within the IM CN subsystem, framing protocols such as RTP are used to transport media packets to and from IM CN subsystem entities such as the UE, MRFP or IMS-MGW.

CS domain access uses circuit switched bearer channels like TDM circuits (e.g. 64kbits PCM), ATM/AAL2 circuits or IP bearers using the IuFP framing protocol or RTP to carry voice frames.

Therefore, in order to provide the required interworking to enable ICS for a UE using CS domain access, the user plane protocols shall be interworked within the CS-MGW, under the control of the MSC Server.

5 Control plane procedures and interworking

5.1 General

The following subclauses define the procedures and signalling interworking performed by the MSC Server to enable ICS for UEs attached to the CS domain. The interworking between NAS signalling and the Session Initiation Protocol (SIP) with its associated Session Description Protocol (SDP) is specified.

The capabilities of SIP and SDP that are interworked with NAS signalling are defined in 3GPP TS 24.229 [2].

Table 5.1.1 lists the service interworking within the scope of the present document.

Table 5.1.1: Interworking between NAS signalling and SIP/SDP

Telephony or Supplementary Service
TS11 non-emergency speech calls
Originating Identification Presentation (OIP)
Originating Identification Restriction (OIR)
Terminating Identification presentation (TIP)
Terminating Identification restriction (TIR)
Communication Hold and Resume
Communication Waiting
Communication Barring
Communication Diversion
Explicit Communication Transfer
Conferencing
Communication Completion to Busy Subscriber (CCBS)
Communication Completion on No Reply (CCNR)
Communication Completion on Not Logged-in (CCNL)

5.2 IMS registration procedures interworking

5.2.1 Initial registration

Upon successful completion of the location updating procedure as specified in 3GPP TS 24.008 [3], an MSC Server supporting the ICS Indicator parameter as specified in 3GPP TS 29.002 [20] shall determine whether to perform initial IMS registration on behalf of the UE.

The relevant location update case, when an initial registration is needed to the IM CN subsystem is a location update to new MSC/VLR service area (the MSC/VLR was not the previous serving network element).

In accordance with 3GPP TS 23.292 [5], subclause 7.2.1.1, the MSC Server may perform an initial IMS registration. The optional flag referred to in subclause 7.2.1.1 of 3GPP TS 23.292 [5] is implemented as the ICS Indicator parameter in 3GPP TS 29.002 [20].

When performing initial IMS registration, the MSC Server shall send a REGISTER request on behalf of the UE as described in 3GPP TS 24.292 [7].

5.2.2 Reregistration

The MSC Server shall initiate reregistration for a previously registered Public User Identity as described in 3GPP TS 24.292 [7] if that subscriber is still registered in the MSC Server via CS domain access.

5.2.3 MSC Server initiated deregistration

The MSC Server shall send a REGISTER request for deregistration on behalf of the UE as described in 3GPP TS 24.292 [7] upon receipt of any indication that the subscriber is no longer registered in this MSC Server.

Prior to sending a REGISTER request for deregistration, the MSC Server shall release all IMS dialogs related to the Public User Identity that is going to be deregistered or to one of the implicitly registered Public User Identities.

5.3 Interworking of mobile originating call setup from NAS signalling to SIP

5.3.1 General

The mobile originating call shall be established in accordance with 3GPP TS 23.018 [8] and 3GPP TS 24.008 [3]. The IM CN subsystem originating session shall be established in accordance with 3GPP TS 24.292 [7] and 3GPP TS 24.229 [2]. The following subclauses describe the additional requirements for interworking between NAS signalling and SIP.

The following subclauses also assume the originating call is received from a subscriber with an active IM CN subsystem registration via the MSC Server performing the interworking.

5.3.2 Receipt of a setup message

Upon receipt of a setup message (a SETUP message or an EMERGENCY SETUP message), the MSC Server shall determine whether the originating call shall be directed to the IM CN subsystem.

The originating call shall be directed to the IM CN subsystem if all of the following conditions are met:

- the setup message is a SETUP message and is determined by the MSC Server not to be an emergency call, and
- the bearer capability 1 information element indicates teleservice 11 as described in 3GPP TS 22.003 [9], and
- the CTM text telephony indication in the bearer capability 1 information element is set to "CTM text telephony is not supported", and
- the bearer capability 2 information element is not present.

Otherwise the originating call shall be handled by the MSC Server without interworking to the IM CN subsystem.

5.3.3 Sending of INVITE

5.3.3.1 General

Upon determining that an incoming SETUP message shall be interworked to the IM CN subsystem, the MSC Server shall generate an INVITE request as further detailed in the subclauses below.

5.3.3.2 Coding of INVITE

The INVITE request shall be coded as described in 3GPP TS 24.292 [7] with the following SETUP message interworking applied:

- The called party BCD number information element in the SETUP message is used to derive the Request URI of the INVITE request as follows:
 - if the type of number field is set to "international number", then the number digit fields, prefixed with a "+", shall be used to build a tel URI or a SIP URI with "user=phone"; or
 - if the type of number field is set to "national number", then the MSC Server shall either:
 - convert the number to international format by prefixing the number digits with "+CC" and use this to build a tel URI or a SIP URI with "user=phone"; or

NOTE 1: CC is the country code of the network in which the MSC Server is located.

- use the number digit fields to build a tel URI or a SIP URI with "user=phone". The phone-context parameter shall include the home network domain name defined for IMS centralized services in 3GPP TS 23.003 [10]. For geo-local numbers, the home domain name shall be prefixed by the "geo-local" string according to 3GPP TS 24.229 [2].

NOTE 2: The manner in which the MSC Server distinguishes between geo-local and home-local numbers is implementation specific.

- if the type of number field is set to "unknown", then the MSC Server shall build a SIP URI with "user=phone" or a tel URI, including the received digits as an unprocessed dial string to the IM CN subsystem, using one of the formats for UEs without dial string processing capabilities, as defined in 3GPP TS 24.229 [2], subclause 5.1.2A.1.3;

NOTE 3: This sets the requirement that the dialling plan is designed so it enables the IM CN subsystem to differentiate local numbers from other numbers; refer to subclause 5.1.2A.1.3.

- if the CLIR invocation information element is present in the SETUP message, the From header shall be set to an Anonymous User Identity as defined in 3GPP TS 23.003 [10] and the MSC Server shall include a Privacy header with priv-value set to "id";
- if the CLIR suppression information element is present in the SETUP message, the MSC Server shall include a Privacy header with priv-value set to "none";
- if the CLIR invocation information element and CLIR suppression information element are not present in the SETUP message, the MSC Server shall not include a Privacy header;
- the P-Asserted-Identity header shall be set to the default public identity received during registration procedures;
- the Contact header shall be set to:
 - the public GRUU received at registration as specified in 3GPP TS 24.229 [11]; or
 - if the CLIR suppression information element is present in the SETUP message to the temporary GRUU received at registration as specified in 3GPP TS 24.229 [11].

When a SIP URI is used for the Request URI, the host portion of the SIP URI shall be set to the home network domain name defined for IMS centralized services in 3GPP TS 23.003 [10].

If the MSC server supports the P-Early-Media header as a network option, then it shall include the header in each outgoing SIP INVITE request.

The MSC Server shall include a P-Charging-Vector header field in the initial INVITE request with an "icid-value" header field parameter as specified in 3GPP TS 32.260 [54].

5.3.3.3 Coding of the SDP offer

The MSC Server shall determine the speech codecs supported by the UE as specified in 3GPP TS 24.008 [3] and use this information when constructing a codec list for the SDP offer. The MSC Server may also add speech codecs. The added speech codecs are based on configuration data in the MSC Server.

If the access bearer establishment has been initiated prior to the sending of the INVITE request (e.g. no speech codec or one speech codec is indicated from the originating UE) the MSC Server shall indicate that preconditions have been met in the initial SDP offer. The MSC Server may indicate in the bearer establishment procedure to the UE the speech codec the UE shall use.

If access side bearer establishment has not been performed prior to sending the INVITE request, the MSC Server shall indicate that preconditions have not been met in the SDP offer. Once access side bearer establishment has been performed, the MSC Server shall indicate that preconditions have been met in a new SDP offer in a subsequent UPDATE or PRACK request.

5.3.3.4 Actions on the SDP answer

At the receipt of the SDP answer the MSC Server shall analyse the received speech codecs:

- If the received speech codecs in the SDP answer do not include any of the speech codecs provided by the UE in the SETUP message or the SDP answer only include the default speech codec the MSC Server shall instruct the CS-MGW to perform transcoding and indicate in the bearer establishment procedure to the UE the speech codec the UE shall use. Which of the codecs used is based on local policy;
- if only one speech codec is received in the SDP answer, the MSC Server shall select that speech codec and may indicate the speech codec in the bearer establishment procedure to the UE;
- if more than one speech codec is received in the SDP answer the MSC Server shall select one codec based on local configuration and may indicate the speech codec in the bearer establishment procedure to the UE; and send a new SDP offer which shall indicate the speech codec that the MSC Server has selected.

For UTRAN and GERAN Iu-mode, the NAS Synchronisation Indicator information element shall be used to inform the UE of the selected codec as specified in 3GPP TS 24.008 [3].

5.3.4 Sending of ALERTING

The MSC Server shall send an ALERTING message towards the UE upon receiving the first 180 Ringing response.

5.3.4a Sending of PROGRESS

Once all the following conditions have been met:

- 1) the MSC server supports the P-Early-Media header field, and received the first SIP 183 Session Progress response that includes a P-Early-Media header field authorizing backward early media;
- 2) SDP preconditions are not used, or applicable SDP preconditions have been met; and
- 3) the MSC server did not receive a SIP 180 Ringing;

then the MSC server shall send a PROGRESS message.

5.3.4b Through-Connecting early media from IMS

If a SIP 18x response is received by the MSC server, once all the following conditions have been met:

- 1) the MSC server supports the P-Early-Media header field, and the response includes a P-Early-Media header field authorizing backward early media; and
- 2) SDP preconditions are not used, or applicable SDP preconditions have been met;

then the MSC server shall instruct the CS-MGW to through-connect as described in subclause 7.1.5 for early media from the IMS side unless the CS-MGW has already been through-connected.

NOTE: An MSC server supporting the early session model CAT supplementary service applies additional procedure described in subclause 5.6.9.

5.3.5 Applying ringback tone

The MSC Server shall instruct the CS-MGW to apply ringback tone towards the UE in the following conditions:

- a 180 Ringing response is received and either:
 - the MSC Server does not support the P-Early-Media header as a network option; or
 - the MSC Server supports the P-Early-Media header as a network option and according to IETF RFC 5009 [47] backward early media is not authorized (the most recently received P-Early-Media header does not authorize backward early media or the P-Early-Media header has not yet been received).

5.3.6 Receipt of 200 OK (INVITE)

Upon receipt of the first 200 OK (INVITE) response, the MSC Server shall:

- instruct the CS-MGW to stop ringback if ringback was previously applied; and
- instruct the CS-MGW to through-connect the bearer in both directions; and
- send a CONNECT message towards the UE as described in 3GPP TS 24.008 [3].

Interworking applied for the TIP service is described in subclause 5.6.2.1.

The MSC Server shall not progress any further early dialogs to established dialogs. Therefore, upon receipt of a subsequent 200 OK final response to the initial INVITE request (e.g. due to forking), the MSC Server shall:

- acknowledge the response with an ACK request; and
- send a BYE request to this dialog in order to terminate it.

5.3.7 Receipt of status-codes 3xx

Upon receipt of a 3xx response to the initial INVITE, the default behaviour of the MSC Server shall be to release the call with a cause code value of 127 (Interworking unspecified).

NOTE: The MSC Server may also decide to redirect the call toward the URI in the Contact header field of the 3xx response, as an operator option. Such handling is outside the scope of the present document.

5.3.8 Receipt of SIP status-codes 4xx, 5xx or 6xx

If the MSC Server receives a 4xx, 5xx or 6xx SIP response to the initial SIP INVITE request and the MSC Server has not sent a SIP CANCEL request, the MSC Server shall initiate call clearing procedures by sending a CC DISCONNECT message towards the UE as described in 3GPP TS 24.008 [3] with the following interworking applied:

- 1) If one or more Reason header fields are included in the 4xx, 5xx or 6xx SIP response, then the cause value of each Reason header field shall be mapped to a cause information element in the CC DISCONNECT message as follows:
 - a) if the Reason header field contains a Q.850 cause value, the numeric cause code shall be mapped directly to the cause value octet of the cause information element in the CC DISCONNECT message;

- b) if the Reason header field contains a SIP status-code, the coding of the cause information element in the CC DISCONNECT message shall be as follows:
- set the coding standard to "Standard defined for the GSM PLMNs";
 - set the location to "network beyond interworking point"; and
 - derive the cause value from the SIP status-code received in the Reason header field according to table 5.3.8.1. The 4xx, 5xx, and 6xx SIP responses that are not covered in this table shall be interworked to a cause value of 127 (Interworking, unspecified); and
- c) if no Reason header field is included in the 4xx, 5xx or 6xx SIP response, the coding of the cause information element in the CC DISCONNECT message is derived from the SIP status-code of the SIP response according to table 5.3.8.1, where the following information elements shall be set to:
- coding standard to "Standard defined for the GSM PLMNs"; and
 - location to "network beyond interworking point".

Table 5.3.8.1: Mapping the 4xx/5xx/6xx status-code to the cause information element

SIP status-code	Cause value
400 Bad Request	127 (Interworking, unspecified)
401 Unauthorized	127 (Interworking, unspecified)
402 Payment Required	127 (Interworking, unspecified)
403 Forbidden	127 (Interworking, unspecified)
404 Not Found	1 (Unassigned (unallocated) number)
405 Method Not Allowed	127 (Interworking, unspecified)
406 Not Acceptable	127 (Interworking, unspecified)
407 Proxy authentication required	127 (Interworking, unspecified)
408 Request Timeout	127 (Interworking, unspecified)
410 Gone	22 (Number changed)
413 Request Entity too long	127 (Interworking, unspecified)
414 Request-URI too long	127 (Interworking, unspecified)
415 Unsupported Media type	127 (Interworking, unspecified)
416 Unsupported URI scheme	127 (Interworking, unspecified)
420 Bad Extension	127 (Interworking, unspecified)
421 Extension required	127 (Interworking, unspecified)
423 Interval Too Brief	127 (Interworking, unspecified)
433 Anonymity Disallowed	24 (Call rejected due to feature at the destination)
480 Temporarily Unavailable	41 (Temporary Failure)
481 Call/Transaction does not exist	127 (Interworking, unspecified)
482 Loop detected	127 (Interworking, unspecified)
483 Too many hops	127 (Interworking, unspecified)
484 Address Incomplete	28 (Invalid number format (incomplete number))
485 Ambiguous	127 (Interworking, unspecified)

SIP status-code	Cause value
486 Busy Here	17 (User busy)
487 Request terminated	127 (Interworking, unspecified)
488 Not acceptable here	127 (Interworking, unspecified)
493 Undecipherable	127 (Interworking, unspecified)
500 Server Internal error	127 (Interworking, unspecified)
501 Not implemented	127 (Interworking, unspecified)
502 Bad Gateway	127 (Interworking, unspecified)
503 Service Unavailable	127 (Interworking, unspecified)
504 Server timeout	127 (Interworking, unspecified)
505 Version not supported	127 (Interworking, unspecified)
513 Message too large	127 (Interworking, unspecified)
580 Precondition failure	127 (Interworking, unspecified)
600 Busy Everywhere	17 (User busy)
603 Decline	21 (Call rejected)
604 Does not exist anywhere	1 (Unassigned (unallocated) number)
606 Not acceptable	127 (Interworking, unspecified)

If the MSC Server supports restoration procedures, the MSC Server shall in addition to the procedures in this subclause perform the procedures in subclause 5.3.10.

5.3.9 Receipt of DISCONNECT

If the MSC Server receives a DISCONNECT message from the UE prior to receiving a final response to the initial INVITE, the MSC Server shall send a CANCEL request. If a 200 OK response to the initial INVITE is received after sending the CANCEL request, the MSC Server shall send a BYE request to the IM CN subsystem to terminate the session.

If the DISCONNECT message contains one or more cause information elements, the first cause information element shall be mapped to a Reason header field in the CANCEL or BYE request as follows:

- set the protocol field to "Q.850"; and
- set the protocol-cause field to the cause value field of the cause information element.

NOTE: The inclusion of reason-text in the Reason header is implementation specific.

5.3.10 Restoration procedures

If the MSC Server receives a SIP 504 (Server Time-out) response and all the following conditions are fulfilled:

- 1) there is no re-registration ongoing;
- 2) a P-Asserted-Identity header field set to a value equal to an URI:
 - from the Service-Route header field value received during registration; or
 - from the Path header field value received during registration; and
- 3) the SIP response contains a Content-Type header field set to "application/3gpp-ims+xml" as defined in 3GPP TS 24.229 [2] subclause 7.6; and

4) the SIP response includes an IM CN subsystem XML body as specified in 3GPP TS 24.229 [2] subclause 7.6 with the <ims-3gpp> element, including a version attribute, with the <alternative-service> child element:

- with the <type> child element set to "restoration" (see 3GPP TS 24.229 [2] table 7.6.2); and
- with the <action> child element set to "initial-registration" (see 3GPP TS 24.229 [2] table 7.6.3);

then the MSC Server shall initiate restoration procedures by performing an initial registration as specified in subclause 5.2.1.

If the MSC Server is unsuccessful to send an initial SIP INVITE request to the next hop determined by one of the following:

- there is no response to the SIP INVITE request by the MSC Server; or
- by unspecified means available to the MSC Server;

and if there is no re-registration ongoing then the MSC Server may initiate restoration procedures by performing an initial registration as specified in subclause 5.2.1.

NOTE: If there is an ongoing re-registration and the conditions in this subclause for initiating an initial registration were fulfilled the MSC Server regards this user as not registered and waits until a successful registration before sending any more INVITE request for this user. Meanwhile the MSC Server can fall back to the procedures for non ICS UE attached to a legacy MSC for call establishment as described in 3GPP TS 23.292 [5].

5.4 Interworking of mobile terminating call setup from SIP to NAS signalling

5.4.1 General

The IM CN subsystem terminating session shall be established in accordance with 3GPP TS 24.292 [7] and 3GPP TS 24.229 [2]. The mobile terminating call shall be established at the visited MSC Server in accordance with 3GPP TS 23.018 [8] and 3GPP TS 24.008 [3]. The following subclauses describe the additional requirements for interworking between SIP and NAS signalling.

5.4.2 Receipt of initial INVITE

Upon receipt of an initial INVITE request, the MSC Server shall validate the INVITE request and SDP offer, if present, as described in 3GPP TS 24.292 [7].

After validating the INVITE request, the terminating party shall be validated as follows:

- the MSC Server shall identify the terminating subscriber using the P-Called-Party-ID header or Request-URI from the INVITE request and use this to retrieve the VLR data;
- if the VLR data cannot be retrieved, the MSC Server shall send a 500 Server Internal Error response to the INVITE request;
- if the VLR data can be retrieved, the following check shall be performed:
 - if the IMSI is detached, the MSC Server shall send a 500 Server Internal Error response to the INVITE request.

Upon successful validation of the terminating party, the MSC Server shall initiate the establishment of a MM connection as specified in 3GPP TS 24.008 [3]. If a MM connection cannot be established (e.g. no PAGE RESPONSE message is received), the MSC Server shall send a 408 Request Timeout response to the INVITE request.

If the initial INVITE request includes a MIME body (part) according to subclause 4.4.1 of 3GPP TS 24.615 [44] with the "communication-waiting-indication" element contained in the "ims-cw" root element according to 3GPP TS 24.615 [44], and if the MSC Server determines that the incoming call can be presented to the subscriber as described in 3GPP TS 24.083 [26], then subclause 5.6.4.1 applies.

NOTE: Subclause 5.6.8.3.1.4 contains additional applicable procedures executed upon receipt of an initial INVITE request if the MSC Server is as conference participant.

The MSC Server shall store the "icid-value" header field parameter received in the P-Charging-Vector header field.

5.4.3 Sending of SETUP

After successful MM connection establishment, the MSC Server shall send a SETUP message as described in 3GPP TS 24.008 [3] with the following INVITE request interworking applied:

- The MSC Server may include a bearer capability 1 information element set to indicate teleservice 11 as described in 3GPP TS 22.003 [9];
- The MSC Server shall not include a bearer capability 2 information element;
- If a P-Asserted-Identity header containing a tel URI or a SIP URI with "user=phone" is present, the MSC Server shall use this header to build a calling party BCD number information element as follows:
 - if the tel URI or number within the SIP URI is in international format, set the type of number to "international number", otherwise set the type of number to "national number"; and
 - set the number plan identification to "ISDN/telephony numbering plan"; and
 - set the presentation indicator to "presentation allowed"; and
 - set the screening indicator to "network provided"; and
 - set the number digits fields to the telephone number contained in the tel URI or SIP URI;

NOTE 1: If the P-Asserted-Identity header contains both a tel URI and a SIP URI with "user=phone", the URI used for mapping is implementation specific.

NOTE 2: The number mapping does not include any digits contained in the phone-context parameter.

- If a P-Asserted-Identity header is present but does not contain a tel URI or a SIP URI with "user=phone", the following applies:
 - If a display name is present in the P-Asserted-Identity header, and if no Privacy header with priv-value set to "id" is present, and if the MSC Server supports the network option of mapping display name to calling name identity, the MSC Server may use the P-Asserted-Identity header to build a facility information element with a name indicator parameter set to the display name.

NOTE 3: Interworking of display name received in conjunction with a tel URI or SIP URI to calling name presentation using CNAP is subject to local regulatory requirements on calling line identity and whether the originating network of the call is trusted to provide an authentic identity.

- If no display name is present in any P-Asserted-Identity header, or if the MSC Server does not support the network option of mapping a display name to calling name identity, the MSC Server shall build a calling party BCD number information element as follows:
 - set the type of number to "unknown"; and
 - set the number plan identification to "unknown"; and
 - set the presentation indicator to "number not available due to interworking"; and
 - set the screening indicator to "network provided"; and
 - do not include any number digits fields;
- If no P-Asserted-Identity header is present but a Privacy header with priv-value set to "id" is present, the MSC Server shall build a calling party BCD number information element as follows:
 - set the type of number to "unknown"; and
 - set the number plan identification to "unknown"; and

- set the presentation indicator to "presentation restricted"; and
- set the screening indicator to "network provided"; and
- do not include any number digits fields;
- If neither a P-Asserted-Identity header nor a Privacy header field with a priv-value set to "id" is present, then the MSC Server shall include no calling party BCD number information element.
- If a P-Asserted-Identity header containing a tel URI or a SIP URI with "user=phone" and a Privacy header with priv-value set to "id" are present, the MSC Server shall build a calling party BCD number information element as follows:
 - set the type of number to "unknown"; and
 - set the number plan identification to "unknown"; and
 - set the presentation indicator to "presentation restricted"; and
 - set the screening indicator to "network provided"; and
 - do not include any number digits fields.

5.4.4 Receipt of CALL CONFIRMED

Upon receipt of a CALL CONFIRMED message:

- if a bearer capabilities 1 information element is present and indicates a teleservice other than 11 as described in 3GPP TS 22.003 [9], the MSC Server shall initiate call clearing procedures using a cause value of 58 (bearer capability not presently available);
- if a bearer capabilities 1 information element is present and includes a CTM text telephony indication set to "CTM text telephony is supported", the default behaviour of the MSC Server shall be to continue with call setup but not to provide user plane interworking between CTM and RTP-text at the CS-MGW.

NOTE: Conversion between CTM as described in 3GPP TS 26.226 [22] and RTP-text as described in 3GPP TS 26.235 [21] may be provided as an implementation option if the SDP offer included the payload type for RTP-text. Such conversion is outside the scope of the present document.

5.4.5 Bearer establishment

5.4.5.1 Network side bearer establishment

If the initial INVITE request contained an SDP offer, the MSC Server should use the codecs received in the SDP offer and determine the codecs supported by the UE as specified in 3GPP TS 24.008 [3] to select and return a single codec in the SDP answer.

The MSC Server shall reject all non-audio media descriptions from the SDP offer in the SDP answer.

The SDP answer shall be returned in the first reliable response.

If the initial INVITE request did not contain an SDP offer, the MSC Server should determine the codecs supported by the UE as specified in 3GPP TS 24.008 [3] and use this information when constructing a codec list for the SDP offer and send the SDP offer in the first reliable response to the INVITE request.

5.4.5.2 Access bearer assignment

The MSC Server shall initiate access bearer assignment only after the following conditions are satisfied:

- the incoming side RTP connection point has been successfully reserved and configured in the CS-MGW; and
- either:
 - preconditions were not requested in the SDP of the initial INVITE request; or

- an SDP offer has been received indicating that remote preconditions have been met.

For UTRAN and GERAN Iu-mode, the NAS Synchronisation Indicator information element shall be used to inform the UE of the selected codec as specified in 3GPP TS 24.008 [3].

5.4.5.3 Transcoding

The CS-MGW may include a speech transcoder based upon the speech coding information provided to each bearer termination.

5.4.6 Receipt of ALERTING

Upon receipt of the ALERTING message from the UE, the MSC Server shall send a 180 Ringing response.

NOTE: Starting timer T301 (or a corresponding internal alerting supervision timing function) as specified in 3GPP TS 24.008 [3] at the MSC Server is an implementation option. The default value for T301 in 3GPP TS 24.008 [3] is longer than the range specified for the IM CN subsystem's no reply timer specified in 3GPP TS 24.604 [23], which should allow the IM CN subsystem to properly control CFNA. However, if T301 is started and expires prior to the no reply timer in the IM CN subsystem, the non-2xx response returned to the IM CN subsystem will prevent invocation of the CFNA service.

5.4.7 Applying early media

The MSC Server may instruct the CS-MGW to apply ringback tone or an announcement towards the IM CN subsystem in the following condition:

- the MSC Server supports the P-Early-Media header as a network option; and
- the P-Early-Media header was received in the initial INVITE request.

If these conditions are met and the MSC Server chooses to apply early media, the following actions are taken:

- prior to applying an announcement, the MSC Server shall include in the 183 Session Progress response a P-Early-Media header authorizing backward early media;
- prior to applying ringback tone, the MSC Server shall include in the 180 Ringing response a P-Early-Media header authorizing backward early media.

5.4.8 Call rejection or abandonment

5.4.8.1 Receipt of RELEASE COMPLETE or DISCONNECT

If the MSC Server receives a RELEASE COMPLETE or DISCONNECT message from the UE during call establishment, the MSC Server shall send a status-code 4xx or 5xx response to the initial INVITE. The status-code sent shall be determined by examining the first cause information element received in the RELEASE COMPLETE or DISCONNECT message and applying the mapping specified in table 5.4.8.1.1.

Table 5.4.8.1.1: Mapping the cause information element to the 4xx/5xx/6xx status-code

Cause value	SIP status-code
1 (Unassigned (unallocated) number)	404 Not Found
3 (No route to destination)	500 Server Internal Error
6 (Channel unacceptable)	500 Server Internal Error
8 (Operator determined barring)	480 Temporarily Unavailable
16 (Normal call clearing)	480 Temporarily Unavailable
17 (User busy)	486 Busy Here

Cause value	SIP status-code
18 (No user responding)	480 Temporarily Unavailable
19 (User alerting, no answer)	480 Temporarily Unavailable
21 (Call rejected)	603 Decline
22 (Number changed)	410 Gone
25 (Pre-emption)	480 Temporarily Unavailable
26 (Non selected user clearing)	480 Temporarily Unavailable
27 (Destination out of order)	502 Bad Gateway
28 (Invalid number format (incomplete number))	484 Address Incomplete
29 (Facility rejected)	500 Server Internal Error
30 (Response to STATUS ENQUIRY)	500 Server Internal Error
31 (Normal, unspecified)	480 Temporarily Unavailable
34 (No circuit/channel available)	480 Temporarily Unavailable
38 (Network out of order)	500 Server Internal Error
41 (Temporary failure)	500 Server Internal Error
42 (Switching equipment congestion)	500 Server Internal Error
43 (Access information discarded)	500 Server Internal Error
44 (Requested circuit/channel not available)	500 Server Internal Error
47 (Resources unavailable, unspecified)	500 Server Internal Error
49 (Quality of service unavailable)	500 Server Internal Error
50 (Requested facility not subscribed)	500 Server Internal Error
55 (Incoming calls barred within the CUG)	480 Temporarily Unavailable
57 (Bearer capability not authorized)	500 Server Internal Error
58 (Bearer capability not presently available)	500 Server Internal Error
63 (Service or option not available, unspecified)	500 Server Internal Error
65 (Bearer service not implemented)	500 Server Internal Error
68 (ACM equal to or greater than ACMmax)	500 Server Internal Error
69 (Requested facility not implemented)	500 Server Internal Error
70 (Only restricted digital information bearer capability is available)	500 Server Internal Error
79 (Service or option not implemented, unspecified)	500 Server Internal Error
81 (Invalid transaction identifier value)	500 Server Internal Error
87 (User not member of CUG)	480 Temporarily Unavailable
88 (Incompatible destination)	500 Server Internal Error
91 (Invalid transit network selection)	404 Not Found
95 (Semantically incorrect message)	500 Server Internal Error
96 (Invalid mandatory information)	500 Server Internal Error
97 (Message type non-existent or not)	500 Server Internal Error

Cause value	SIP status-code
implemented)	
98 (Message type not compatible with protocol state)	500 Server Internal Error
99 (Information element non-existent or not implemented)	500 Server Internal Error
100 (Conditional IE error)	500 Server Internal Error
101 (Message not compatible with protocol state)	500 Server Internal Error
102 (Recovery on timer expiry)	480 Temporarily Unavailable
111 (Protocol error, unspecified)	500 Server Internal Error
127 (Interworking, unspecified)	480 Temporarily Unavailable

NOTE 1: Alternative mappings are allowed per operator policy.

The first cause information element included in the RELEASE COMPLETE or DISCONNECT message shall be mapped to a Reason header field in the SIP final response sent as a result of this clause as follows:

- set the protocol field to "Q.850"; and
- set the protocol-cause field to the cause value field of the cause information element.

NOTE 2: The inclusion of reason-text in the Reason header is implementation specific.

5.4.8.2 Receipt of CANCEL or BYE

If the MSC Server receives a CANCEL or BYE request, the MSC Server shall initiate call clearing procedures by sending a DISCONNECT message towards the UE as described in 3GPP TS 24.008 [3] with the following interworking applied:

- If one or more Reason headers is included in the CANCEL or BYE request, then the cause value of each Reason header shall be mapped to a cause information element in the DISCONNECT message as follows:
 - if the Reason header contains a Q.850 cause value or a SIP status-code, the cause information element shall be built as described in subclause 5.3.8.
- if no Reason header is included in the CANCEL or BYE request, a cause value set to 31 (normal, unspecified), coding standard set to "Standard defined for the GSM PLMNs" and location set to "network beyond interworking point" shall be used in the cause information element in the DISCONNECT message.

5.4.9 Receipt of CONNECT

Upon receipt of the CONNECT message from the UE, the MSC Server shall send a 200 OK response to the initial INVITE.

Interworking applied for the TIR services is described in subclause 5.6.2.2.

5.4.10 Call failure procedures

The MSC Server shall handle call failures (e.g. timer expiration) during mobile terminating call establishment in accordance with 3GPP TS 24.008 [3]. The cause value used towards the calling user as specified in 3GPP TS 24.008 [3] shall be mapped to a final response to the INVITE request as specified in subclause 5.4.8.1.

5.5 Interworking of established call clearing between NAS signalling and SIP

5.5.1 General

The following subclauses define the procedure and signalling interworking performed by the MSC Server for call clearing of an established call. This interworking is independent of the direction of original call establishment.

Call clearing during call setup is described in subclauses 5.3.7, 5.3.8, 5.3.9, 5.4.8.1 and 5.4.10.

5.5.2 Clearing initiated by the mobile

MSC Server handling of call clearing initiated by the mobile shall be in accordance with 3GPP TS 24.008 [3] with the additional interworking defined here.

Upon receipt of a DISCONNECT message, the MSC Server shall send a BYE request to the IM CN subsystem. The cause information element in the DISCONNECT message shall be mapped to a Reason header in the BYE request according to in subclause 5.4.8.1.

5.5.3 Clearing initiated by the IM CN subsystem

Upon receipt of a BYE request, the MSC Server shall send a DISCONNECT message towards the mobile. If one or more Reason header fields is included in the BYE request, each Reason header field shall be mapped to a cause information element in the DISCONNECT message according to subclause 5.3.8.

If no Reason header is present, a cause information element value of 16 (Normal call clearing) shall be used.

5.5.4 Autonomous clearing initiated by the MSC Server

If the MSC Server determines due to internal procedures that the call shall be released, call release shall be in accordance with 3GPP TS 24.008 [3] with the additional interworking defined here.

The MSC Server shall send a BYE request to the IM CN subsystem. The MSC Server shall align the value used in the cause information element in the DISCONNECT message with the value used in the Q.850 protocol-cause field in the Reason header of the BYE request.

5.6 Supplementary Services invocation

5.6.1 Originating identification presentation/restriction (OIP/OIR)

The interworking required for OIP is defined in subclause 5.4.3.

The interworking required for OIR is defined in subclause 5.3.3.2.

5.6.2 Terminating identification presentation/restriction (TIP/TIR)

5.6.2.1 Terminating identification presentation (TIP)

When interworking a SIP 200 OK (INVITE) response to a CONNECT message as described in subclause 5.3.6, a MSC Server which supports the normal operation of the connected number supplementary service as described in 3GPP TS 24.081 [12] shall apply the following interworking for the TIP supplementary service:

- if a P-Asserted-Identity header containing a tel URI or a SIP URI with "user=phone" is present, the MSC Server shall use this header to build a connected number information element as follows:
 - if the tel URI or number within the userinfo part of the SIP URI is in international format, set the type of number to "international number", otherwise set the type of number to "national number"; and

- set the number plan identification to "ISDN/telephony numbering plan"; and
- set the presentation indicator to "presentation allowed"; and
- set the screening indicator to "network provided"; and
- set the number digits fields to the telephone number contained in the tel URI or the userinfo part of the SIP URI; or

NOTE 1: If the P-Asserted-Identity header contains both a tel URI and a SIP URI with "user=phone", the URI used for mapping is implementation specific.

NOTE 2: The number mapping does not include any digits contained in the phone-context parameter.

- if a P-Asserted-Identity header is present but does not contain a tel URI or a SIP URI with "user=phone", the MSC Server shall build a connected number information element as follows:
 - set the type of number to "unknown"; and
 - set the number plan identification to "unknown"; and
 - set the presentation indicator to "number not available due to interworking"; and
 - set the screening indicator to "network provided"; and
 - do not include any number digits fields; or
- if no P-Asserted-Identity header is present but a Privacy header with priv-value set to "id" is present, the MSC Server shall build a connected number information element as follows:
 - set the type of number to "unknown"; and
 - set the number plan identification to "unknown"; and
 - set the presentation indicator to "presentation restricted"; and
 - set the screening indicator to "network provided"; and
 - do not include any number digits fields; or
- if neither a P-Asserted-Identity header nor a Privacy header field with a priv-value set to "id" is present, then no connected number information element shall be included.

5.6.2.2 Terminating identification restriction (TIR)

The MSC Server shall not include a Privacy header in any response to an INVITE request.

NOTE: 3GPP TS 24.081 [12] does not provide a mechanism for a terminator to temporarily override default settings for this service. The inclusion of a Privacy header could lead to the AS serving the terminating user to mistakenly assume that a default setting is being temporarily overridden by the terminating user. Omitting the Privacy header allows the AS supporting the terminating user to perform the appropriate actions for the TIR service in "permanent mode" as specified in 3GPP TS 24.608 [14].

5.6.3 Communication Hold (HOLD)

5.6.3.1 HOLD initiated via NAS signalling

5.6.3.1.1 Hold

When the MSC Server receives a HOLD message as specified in 3GPP TS 24.083 [26] and the media on the IM CN subsystem side of the CS-MGW is "sendonly" or "inactive", no interworking is required and the MSC Server shall send a HOLD ACKNOWLEDGE message to the UE as specified in 3GPP TS 24.083 [26]. If the media on the IM CN subsystem side is "recvonly" or "sendrecv", the MSC Server shall send an UPDATE or re-INVITE request containing an SDP offer configured as follows:

- mark the media as "sendonly" or "inactive" as described in 3GPP TS 24.610 [27]; and
- if RTCP is disabled for this media stream, include RR and RS bandwidth modifiers with values greater than zero to enable RTCP as described in 3GPP TS 26.114 [28] subclause 7.3.1.

Upon receipt of the SDP answer in a 200 OK response to the UPDATE or re-INVITE request, the MSC Server shall send a HOLD ACKNOWLEDGE message to the UE as specified in 3GPP TS 24.083 [26].

If the SDP offer is rejected or a non-200 response is received to the UPDATE or re-INVITE request, the MSC Server shall send a HOLD REJECT message to the UE as specified in 3GPP TS 24.083 [26] with cause parameter set to "Facility rejected".

5.6.3.1.2 Resume

When the MSC Server receives a RETRIEVE message as specified in 3GPP TS 24.083 [26] and the media on the IM CN subsystem side of the CS-MGW is "recvonly" or "sendrecv", no interworking is required and the MSC Server shall send a RETRIEVE ACKNOWLEDGE message to the UE as specified in 3GPP TS 24.083 [26]. If the media on the IM CN subsystem side is "sendonly" or "inactive", the MSC Server shall send an UPDATE or re-INVITE request containing an SDP offer with media marked as "recvonly" or "sendrecv" as described in 3GPP TS 24.610 [27]. The MSC Server may include RR and RS bandwidth modifiers set to zero in the SDP offer to disable RTCP.

Upon receipt of the SDP answer in a 200 OK response to the UPDATE or re-INVITE request, the MSC Server shall send a RETRIEVE ACKNOWLEDGE message to the UE as specified in 3GPP TS 24.083 [26].

If the SDP offer is rejected or a non-200 response is received to the UPDATE or re-INVITE request, the MSC Server shall send a RETRIEVE REJECT message to the UE as specified in 3GPP TS 24.083 [26] with cause parameter set to "Facility rejected".

5.6.3.2 HOLD initiated via SIP signalling

5.6.3.2.1 Hold

The IM CN subsystem makes a hold request by sending an UPDATE or re-INVITE request with an "inactive" or "sendonly" SDP attribute, depending on the current state of the session. Upon receipt of a hold request from the IM CN subsystem, the MSC Server shall perform the following interworking:

- if the MSC Server received a non-zero SS screening indicator as defined in 3GPP TS 24.080 [29] from the UE, the MSC Server shall send a FACILITY message indicating the call has been placed on hold as specified in 3GPP TS 24.083 [26];
- if the MSC Server did not receive a non-zero SS screening indicator from the UE, the MSC Server shall not send any message to the UE.

5.6.3.2.2 Resume

The IM CN subsystem requests to resume a session by sending an UPDATE or re-INVITE request with an "recvonly" or "sendrecv" SDP attribute, depending on the current state of the session. Upon receipt of a resume request from the IM CN subsystem, the MSC Server shall perform the following interworking:

- if the MSC Server received a non-zero SS screening indicator as defined in 3GPP TS 24.080 [29] from the UE, the MSC Server shall send a FACILITY message indicating the call has been retrieved as specified in 3GPP TS 24.083 [26];
- if the MSC Server did not receive a non-zero SS screening indicator from the UE, the MSC Server shall not send any message to the UE.

5.6.4 Communication Waiting (CW)

5.6.4.1 Receipt of initial INVITE

NOTE: Subclause 5.4.2 contains general applicable procedures executed upon receipt of an initial INVITE request.

If the initial INVITE request includes:

- a MIME body (part) according to subclause 4.4.1 of 3GPP TS 24.615 [44] with the "communication-waiting-indication" element contained in the "ims-cw" root element according to 3GPP TS 24.615 [44]; or
- does not contain a Replaces header field corresponding to a established dialog and the target of the INVITE request is engaged in the established SIP dialog;

then, upon interworking the initial INVITE request to a SETUP message as described in subclause 5.4.3, the MSC Server shall apply the following additional interworking:

- the MSC Server shall include a Signal information element with value 7 (call waiting tone on); and
- if the INVITE request includes a MIME body (part) according to subclause 4.4.1 of 3GPP TS 24.615 [44] with the "communication-waiting-indication" element contained in the "ims-cw" root element according to 3GPP TS 24.615 [44]:
- the MSC Server shall store an indication that this session includes a CW AS; and
- the MSC Server may start timer TUE-CW as described in 3GPP TS 24.615 [44].

If the CALL CONFIRMED message received by the MSC Server during mobile terminating call setup contains a Cause information element set to a value of 17 (User busy), then upon interworking the subsequent ALERTING message to a 180 Ringing response as described in subclause 5.4.6, the MSC Server shall apply the following additional interworking:

- the MSC Server shall insert an Alert-Info header set to "urn:alert:service:call-waiting" as described in 3GPP TS 24.615 [44] into the 180 Ringing response.

5.6.4.2 Accepting the waiting call

If the subscriber chooses to accept the waiting call and put the existing call on hold, the MSC Server shall:

- upon receipt of the HOLD message for the existing call, apply the interworking specified in subclause 5.6.3.1.1; and
- upon receipt of the CONNECT message for the waiting call, stop timer T_{UE-CW} if it was started and apply the interworking specified in subclause 5.4.9.

If the subscriber chooses to accept the waiting call and release the existing call, the MSC Server shall:

- upon receipt of the DISCONNECT message for the existing call, apply the interworking specified in subclause 5.5.2; and
- upon receipt of the CONNECT message for the waiting call, stop timer T_{UE-CW} if it was started and apply the interworking specified in subclause 5.4.9.

5.6.4.3 Rejecting the waiting call

If the MSC Server receives a first clearing message from the UE during call establishment, the cause value used towards the calling user as specified in 3GPP TS 24.008 [3] shall be mapped to a final response to the INVITE request as specified in subclause 5.4.8.1, except for cause codes:

- 19 (User alerting, no answer) and 18 (No user responding). A first clearing message from the UE during call establishment with cause code 19 (User alerting, no answer) or 18 (No user responding) shall be mapped to the 480 (Temporarily unavailable) final response including a Reason header field (see RFC 3326 [45]) with the protocol set to "Q.850" and the cause set to "19" or "18", respectively;
- 63 (Service or option not available, unspecified) and 69 (Requested facility not implemented):
- if the MSC Server stored an indication that the session includes a CW AS, a first clearing message from the UE during call establishment with cause code 63 (Service or option not available, unspecified) or 69 (Requested facility not implemented) used towards the calling user as specified in 3GPP TS 24.008 [3] shall be mapped to the 415 (Unsupported Media Type) final response; or

- if the MSC Server did not store an indication that the session includes a CW AS, the cause codes 63 (Service or option not available, unspecified) and 69 (Requested facility not implemented) used towards the calling user as specified in 3GPP TS 24.008 [3] shall be mapped to a final response to the INVITE request as specified in subclause 5.4.8.1.

The MSC Server shall stop timer T_{UE-CW} if it was started.

5.6.4.4 Communication release during waiting condition

Upon receipt of a BYE or CANCEL request for the waiting call, the MSC Server shall stop timer T_{UE-CW} if it was started, and:

- if the BYE or CANCEL request includes a Reason header field (see RFC 3326 [45]) with the protocol set to "SIP" and the cause set to "408" then the MSC Server shall send a first clearing message according to subclause 5.4.8.2, with the following addition:
 - the Cause information element shall be set to cause 102 "recovery on timer expiry"; or
- the MSC Server shall act in accordance with subclause 5.4.8.2.

5.6.4.5 CW condition timeout

If timer T_{UE-CW} was started and expires, the MSC Server shall:

- send a DISCONNECT message as described in 3GPP TS 24.008 [3], towards the UE for the waiting call, including the Cause information element, where the cause values is set to 102 "recovery on timer expiry", the coding standard set to "Standard defined for the GSM PLMNs" and location set to "network beyond interworking point";
- if the MSC Server stored an indication that the session includes a CW AS, send a 480 (Temporarily unavailable) final response, including a Reason header field set to cause 19, according to 3GPP TS 24.615 [44] in response to the initial INVITE request;
- if the MSC Server did not store an indication that the session includes a CW AS, the MSC Server shall act in accordance with subclause 5.4.10.

NOTE: Starting timer T2 or (optionally) T3 (or corresponding internal alerting supervision timing functions) as specified in 3GPP TS 24.083 [26] is an implementation option. Corresponding timers have been defined in 3GPP TS 24.615 [44] and 3GPP TS 24.604 [23]. If timers T2 or optionally T3 are started and expire, any resulting SIP responses that are not a 480 (Temporarily unavailable) final response, including a Reason header field set to cause 19, can interact with CW and (optionally) CDIV.

5.6.4.6 Notification to originator

For originating calls interworked to the IM CN subsystem as described in subclause 5.3, if the MSC Server receives a 180 Ringing response with a Alert-Info header field set to "urn:alert:service:call-waiting" according to 3GPP TS 24.615 [44], the MSC Server shall, according to 3GPP TS 24.083 [26], send if possible, the ALERTING message as the carrier message for the Call Waiting notification. Otherwise the MSC Server shall send a FACILITY message as the carrier message for the Call Waiting notification as specified in 3GPP TS 24.083 [26].

5.6.5 Communication Barring (CB)

When interworking a 4xx, 5xx or 6xx response to the initial INVITE request to a DISCONNECT message as described in subclause 5.3.8, the MSC Server shall apply the following additional interworking for the CB services described in 3GPP TS 24.611 [31]:

- if a 433 Anonymity Disallowed response is received, the MSC Server shall include in the DISCONNECT a NotifySS operation containing an SS-Code set to the common code for incoming barring services and an SS-Status set to indicate the service is active and operative as specified in 3GPP TS 24.088 [30];

- if a 603 Decline response is received, the MSC Server shall include in the DISCONNECT a NotifySS operation containing an SS-Code set to the common code for all barring services and an SS-Status set to indicate the service is active and operative as specified in 3GPP TS 24.088 [30].

NOTE: The common SS code is used as 3GPP TS 24.611 [31] specifies the use of a 603 Decline response for both the OCB and ICB services.

5.6.6 Communication Diversion

5.6.6.1 General

The following subclauses describe the MSC Server interworking behaviour related to the Communication Diversion (CDIV) services defined in 3GPP TS 24.604 [23].

5.6.6.2 CDIV invocation

5.6.6.2.1 Communication Forwarding Unconditional (CFU)

Invocation of CFU is handled by the IM CN subsystem as described in 3GPP TS 24.604 [23] and requires no interworking at the MSC Server.

5.6.6.2.2 Communication Forwarding Busy (CFB)

For network determined user busy, invocation of CFB is handled by the IM CN subsystem as described in 3GPP TS 24.604 [23] and requires interworking at the MSC Server.

For user determined user busy during mobile terminating call establishment as described in subclause 5.4, if the MSC Server receives a DISCONNECT, RELEASE or RELEASE COMPLETE message from the UE with a cause information element set to "User Busy", the MSC Server shall perform the interworking described in subclause 5.4.8.1.

5.6.6.2.3 Communication Forwarding No Reply (CFNR)

Invocation of CFNR is handled by the IM CN subsystem as described in 3GPP TS 24.604 [23] and requires no interworking at the MSC Server.

5.6.6.2.4 Communication Forwarding on Not Logged-In (CFNL)

Invocation of CFNL is handled by the IM CN subsystem as described in 3GPP TS 24.604 [23] and requires no interworking at the MSC Server.

5.6.6.2.5 Communication Deflection (CD)

During mobile terminating call establishment as described in subclause 5.4, if the MSC Server receives a DISCONNECT message from the UE with a facility information element containing a call deflection request as specified in 3GPP TS 24.072 [25], the MSC Server shall send a 302 Moved Temporarily response to the initial INVITE with the following interworking applied:

- the DeflectedToNumber parameter in the facility information element received in the DISCONNECT message is used to derive a Contact header as follows:
 - if the nature of address indicator is set to "international number", then the address digits in the DeflectedToNumber parameter, prefixed with a "+", shall be used to build a tel URI or a SIP URI with "user=phone"; or
 - if the nature of address indicator is not set to "international number", then the MSC Server shall either:
 - convert the address digits in the DeflectedToNumber parameter to international format by prefixing the number digits with "+CC" and use this to build a tel URI or a SIP URI with "user=phone"; or

NOTE 1: CC is the country code of the network in which the MSC Server is located.

- use the address digits in the DeflectedToNumber parameter to build a tel URI or a SIP URI with "user=phone". The phone-context parameter shall include the home network domain name defined for IMS centralized services in 3GPP TS 23.003 [10]. For geo-local numbers, the home domain name shall be prefixed by the "geo-local" string according to 3GPP TS 24.229 [2].

NOTE 2: The manner in which the MSC Server distinguishes between geo-local and home-local numbers is implementation specific.

5.6.6.2.6 Communication Forwarding on Subscriber Not Reachable (CFNRc)

Subclause 5.4.2 describes a number of scenarios where the MSC Server determines the terminating user is not reachable prior to sending the SETUP message and returns the appropriate response to the INVITE request to allow CFNRc to be initiated in the IM CN subsystem. If the MSC Server determines the terminating user is not reachable prior to sending the SETUP message for any other scenario not described in subclause 5.4.2, the MSC Server shall send a 500 Server Internal Error response to the initial INVITE request.

5.6.6.3 Notifications relating to CDIV

5.6.6.3.1 Communication Diversion Notification (CDIVN)

The default behaviour at the MSC Server is not to issue a subscription for CDIVN.

NOTE: The MSC Server may decide for example to subscribe to CDIVN as specified in 3GPP TS 24.604 [23] as an operator option, but such interworking is outside the scope of the present document.

5.6.6.3.2 Notification to an originating user on CS access

For originating calls interworked to the IM CN subsystem as described in subclause 5.3, if communication diversion occurs for a served user with the subscription option "Originating user receives notification that his communication has been diverted (forwarded or deflected)" as described in 3GPP TS 24.604 [23], the following interworking shall be applied upon receipt of a 181 (Call Is Being Forwarded) response:

- if a History-Info header field is present and any history entry contains a "cause" SIP URI parameter, as defined in IETF RFC 4458 [55] set to a value listed in table 5.6.6.3.2.1, the MSC Server shall send a FACILITY message containing a NotifySS operation indicating the call has been forwarded. The NotifySS operation shall contain an SS-Code as specified in 3GPP TS 24.082 [24] and 3GPP TS 24.072 [25] mapped from the value of the last "cause" SIP URI parameter according to table 5.6.6.3.2.1;

Table 5.6.6.3.2.1: Mapping the History-Info cause value to SS-Code

Cause value	SS-Code
302	CFU
404	Common SS-Code for all forwarding SS
408	CFNRy
480	CD
486	CFB
487	CD
503	CFNRc

NOTE: Per 3GPP TS 24.604 [23] the History-Info header field can also be received in a SIP 180 (Ringling) or SIP 200 (OK) response to the initial SIP INVITE request. No interworking is performed in these scenarios as 3GPP TS 24.082 [24] does not allow this information to be presented to the subscriber in a manner consistent with 3GPP TS 24.604 [23].

5.6.6.3.3 Notification to a terminating user on CS access

When interworking a SIP INVITE request to a SETUP message as described in subclause 5.4.3, the MSC Server shall apply the following interworking to provide notification of CDIV if a History-Info header field is present in the INVITE request:

- if any history entry in the History-Info header field contains a "cause" SIP URI parameter, as defined in IETF RFC 4458 [55], set to a value listed in table 5.6.6.3.2.1, the MSC Server shall send a FACILITY information element containing a NotifySS operation indicating the call has been forwarded. The NotifySS operation shall contain an SS-Code as specified in 3GPP TS 24.082 [24] and 3GPP TS 24.072 [25] mapped from the value of the last "cause" SIP URI parameter according to table 5.6.6.3.2.1.
 - if
 - a) the SIP INVITE request does not contain a Privacy header field with any of the privacy values "header", "session" or "history"; and
 - b) the history entry in the History-Info header field preceding the last history entry in History-Info header field containing a "cause" SIP URI parameter defined in IETF RFC 4458 [55] set to a value listed in table 5.6.6.3.2.1 does not contain an escaped privacy header with a value of "history",
 - then the following additional interworking shall be applied:
 - if the hi-targeted-to-uri within the history entry preceding the last history entry containing a "cause" SIP URI parameter contains a tel URI or a SIP URI with "user=phone", the MSC Server shall include a redirecting party BCD number information element set as follows:
 - if the tel URI or telephone number within the SIP URI is in international format, set the type of number to "international number", otherwise set the type of number to "national number";
 - set the number plan identification to "ISDN/telephony numbering plan";
 - set the presentation indicator to "presentation allowed";
 - set the screening indicator to "network provided"; and
 - set the number digits fields to the telephone number contained in the tel URI or SIP URI;
- NOTE: The number mapping does not include any digits contained in the phone-context parameter.
- otherwise,
 - the MSC Server shall build a redirecting party BCD number information element as follows:
 - set the type of number to "unknown";
 - set the number plan identification to "unknown";
 - set the presentation indicator to "number not available due to interworking"; and
 - set the screening indicator to "network provided".

5.6.7 Explicit Communication Transfer (ECT)

5.6.7.1 General

The following subclauses describe the MSC Server interworking behaviour related to the ECT service defined in 3GPP TS 24.629 [33] and a UE using CS access domain signalling specified in 3GPP TS 24.091 [32].

5.6.7.2 MSC Server as transferor on behalf of UE

When the MSC Server receives a FACILITY message containing an ECT request from a UE with one answered call in a held state and another call in an answered and active or alerting state as specified in 3GPP TS 24.091 [32], the MSC Server shall build and send a REFER request as specified for a transferor UE in 3GPP TS 24.629 [33].

When the MSC Server receives a NOTIFY request on the REFER dialog, interworking shall be applied based upon the SIP response status-code contained in the "message/sipfrag" message body as follows:

- if status-code 100 Trying is received, no interworking is applied;
- if status-code 200 OK is received, the MSC Server shall send a FACILITY message indicating transfer success to the UE as specified in 3GPP TS 24.091 [32]. The MSC Server shall then initiate clearing of the two calls towards the UE as specified in 3GPP TS 24.091 [32] and initiate clearing of the IM CN subsystem session with the transferee as specified in subclause 5.5.4.
- if status-code 503 is received, the MSC Server shall send a FACILITY message with a return error parameter set to "SystemFailure" and leave the two calls from the UE in the conditions they were in prior to the ECT request;
- if any other status-code is received, the MSC Server shall send a FACILITY message with a return error parameter set to "IllegalSS-Operation" and leave the two calls from the UE in the conditions they were in prior to the ECT request.

5.6.7.3 MSC Server as transferee on behalf of UE

5.6.7.3.1 Actions without 3PCC

NOTE 1: CS domain access signalling as specified in 3GPP TS 24.091 [32] does not provide a mechanism to present the transfer request to the transferee for authorization of the transfer. Automatic acceptance and execution of the REFER request by the MSC Server can therefore pose a security risk or have unwanted charging consequences. Acceptance of REFER requests is therefore subject to operator policy, which is outside the scope of the present document.

When the MSC Server receives a REFER request in the context of a call transfer scenario as described in 3GPP TS 24.629 [33] subclause 4.5.2.4.1.2.2, the MSC Server may perform the actions specified for a transferee UE in 3GPP TS 24.629 [33].

If the MSC Server does not support accepting REFER requests on behalf of the UE per operator policy, then the MSC Server shall return a 403 Forbidden response.

If the MSC Server received a non-zero SS screening indicator from the UE as defined in 3GPP TS 24.080 [29], then upon sending the NOTIFY request indicating that the transfer is complete, the MSC Server may send a FACILITY message to the UE as specified in 3GPP TS 24.091 [32]. The MSC Server may include an Rdn parameter set to indicate that the remote party number is not available due to interworking.

NOTE 2: The remote party number, as indicated in the Refer-To header sent by the transferor, is not available to the MSC Server as it is replaced by the transferor AS as specified in 3GPP 24.629 [33].

NOTE 3: Depending on the conferencing implementation in the IM CN subsystem (e.g. the manner in which users are invited to a conference), the MSC Server might not be able to distinguish between REFER requests for the ECT service and REFER requests for the conferencing service. In such cases, the MSC Server will not know which SS operation to indicate in the FACILITY message. Handling of this scenario is implementation specific.

5.6.7.3.2 Actions with 3PCC

When 3PCC is used for ECT as specified in 3GPP TS 24.629 [33], no special interworking is required at the MSC Server.

5.6.7.4 MSC Server as transfer target on behalf of UE

When the MSC Server receives an INVITE request which does not replace an existing session (e.g. blind ECT), the MSC Server shall follow the interworking procedures specified in subclause 5.4.

When the MSC Server receives an INVITE request which replaces an existing session, the MSC Server shall perform the actions specified for a transfer target UE in 3GPP TS 24.629 [33]. If the MSC Server received a non-zero SS screening indicator as defined in 3GPP TS 24.080 [29], then upon successful session establishment with the transferee the MSC Server shall send a FACILITY message to the UE as specified in 3GPP TS 24.091 [32] with the following interworking applied:

- if a Privacy header with priv-value set to "id" is present, the MSC Server may include an Rdn parameter in the FACILITY message set to indicate presentation restricted as specified in 3GPP TS 24.080 [29];
- if a Privacy header with a priv-value set to "id" is not present in the INVITE request, then:
 - if a P-Asserted-Identity header containing a tel URI or a SIP URI with "user=phone" is present in the INVITE, the MSC Server may include an Rdn parameter in the FACILITY message with a value set to the telephone number contained in this URI;
 - if a P-Asserted-Identity header is present but does not contain a tel URI or a SIP URI with "user=phone", the MSC Server may include an Rdn parameter in the FACILITY message set to indicate the number is not available due to interworking as specified in 3GPP TS 24.080 [29].

5.6.8 Conference (CONF)

5.6.8.1 General

IM CN subsystem CONF functionality at a MSC Server is specified in 3GPP TS 24.292 [7]. The following subclauses describe the MSC Server interworking behaviour related to the CONF service defined in 3GPP TS 24.605 [35] and a UE using CS access domain signalling specified in 3GPP TS 24.084 [34].

5.6.8.2 MSC Server as conference creator

5.6.8.2.1 Conference creation

When the MSC Server receives a BuildMPTY request from a UE with one active call and one held call as described in 3GPP TS 24.084 [34], the MSC Server shall initiate conference creation and invite the remote parties to the conference as described in 3GPP TS 24.292 [7].

NOTE: Conference creation and inviting users to the conference are two distinct actions in the IM CN subsystem. However, in CS access signalling a single message creates the conference and adds the existing calls to the conference.

After receiving NOTIFY requests indicating both remote parties have successfully transferred to the conference, the MSC Server shall send a FACILITY message indicating BuildMPTY success as specified in 3GPP 24.084 [34].

If a non-200 response to the INVITE request which attempts to create the conference is received, the MSC Server shall send a FACILITY message with a return error parameter set to "SystemFailure" and leave the two calls from the UE in the conditions they were in prior to the ECT request.

5.6.8.2.2 Putting the conference on hold

When the MSC Server receives a HoldMPTY request from a UE with an active conference, the MSC Server shall send an UPDATE or re-INVITE request containing a new SDP offer as described in subclause 5.6.3.1.1.

Upon receipt of the SDP answer in a 200 OK response to the UPDATE or re-INVITE request, the MSC Server shall send a FACILITY message indicating success as specified in 3GPP TS 24.084 [34].

If the SDP offer is rejected or a non-200 response is received to the UPDATE or re-INVITE request, the MSC Server shall send a FACILITY message as specified in 3GPP TS 24.084 [34] with a return error parameter set to "SystemFailure".

5.6.8.2.3 Resuming a held conference

When the MSC Server receives a RetrieveMPTY request from a UE with a conference on hold, the MSC Server shall send an UPDATE or re-INVITE request containing a new SDP offer as described in subclause 5.6.3.1.2.

Upon receipt of the SDP answer in a 200 OK response to the UPDATE or re-INVITE request, the MSC Server shall send a FACILITY message indicating success as specified in 3GPP TS 24.084 [34].

If the SDP offer is rejected or a non-200 response is received to the UPDATE or re-INVITE request, the MSC Server shall send a FACILITY message with a return error parameter set to "SystemFailure".

5.6.8.2.4 Adding a party to the conference

When the MSC Server receives a BuildMPTY from a UE with a conference on hold and separate active or waiting call as described in 3GPP TS 24.084 [34], the MSC Server shall:

- invite the remote party to the conference as described in 3GPP TS 24.292 [7]; and
- send an UPDATE or re-INVITE request to resume the held conference as described in subclause 5.6.3.1.2.

5.6.8.2.5 Terminating the conference or disconnecting a party from the conference

When the MSC Server receives a DISCONNECT message from a UE with an established conference, with a transaction identifier corresponding to a specific remote party, the MSC Server shall start a conference termination specific timer. While the timer is running, MSC Server shall collect potential further DISCONNECT messages from the UE, with valid transaction identifiers, corresponding to other remote parties. These additional DISCONNECT messages shall not trigger starting a new timer and shall not restart the timer.

NOTE 1: The value for the conference termination timer is implementation specific. The timer has to be long enough to allow that the UE encodes and transmits all the DISCONNECT messages to the MSC Server but it should be kept short so that the DISCONNECT messages used for disconnecting a single conference participant are not delayed too long. A value around 1 sec is seen as satisfactory.

When the timer expires, MSC Server shall examine, whether it has received a DISCONNECT message corresponding to all remote parties that have been participants of the established conference and depending on that shall act as follows:

- If a DISCONNECT messages has been received for each participant, the MSC Server shall send a BYE request to the conference-URI.

NOTE 2: A complete set of DISCONNECT messages is interpreted as request to terminate the established conference. The BYE request will lead to a termination of the conference by the conference focus, after removal all the participants, as described in 3GPP TS 24.147 [36], subclause 5.3.2.7.

- Otherwise, the MSC Server shall generate a separate REFER request for each DISCONNECT message to remove the corresponding party/parties from the conference as specified in 3GPP TS 24.147 [36] subclause 5.3.1.6.3, with the Refer-To header of the REFER request set to the address of the conference participant being removed and also containing a "method" URI parameter set to "BYE".

NOTE 3: The MSC Server thus treats the DISCONNECT message(s) received before timer expiry as the user's request for disconnecting the party/parties belonging to the received transaction identity/identities.

5.6.8.2.6 Receipt of a SplitMPTY message

When the MSC Server receives a SplitMPTY request from the UE, the MSC Server shall send a FACILITY message with a return error parameter set to "ss-NotAvailable".

5.6.8.3 MSC Server as conference participant

5.6.8.3.1 Receipt of invitation to conference

5.6.8.3.1.1 General

The methods by which the MSC Server, on behalf of the UE, can be invited to a conference are described in 3GPP TS 24.605[35] subclause 4.5.2.1.2 and 3GPP TS 24.147 [36] subclause 5.3.1.5.

5.6.8.3.1.2 Receipt of REFER within a dialog

Upon receipt of a REFER request within a dialog, the MSC Server shall act as a transferee on behalf of the UE as specified in subclause 5.6.7.3.1.

NOTE 1: If the Refer-To header of the REFER request contains a conference URI, this will result in the user joining a conference.

NOTE 2: CS domain access signalling as specified in 3GPP TS 24.091 [32] does not provide a mechanism to present the transfer request to the transferee for authorization of the transfer. Automatic acceptance and execution of the REFER request by the MSC Server can therefore pose a security risk or have unwanted charging consequences. Acceptance of REFER requests is therefore subject to operator policy, which is outside the scope of the present document.

5.6.8.3.1.3 Receipt of REFER outside a dialog

If the MSC Server does not support accepting REFER requests on behalf of the UE per operator policy, then the MSC Server shall return a 403 Forbidden response.

Support for the MSC Server, on behalf of a UE, joining a conference in this manner requires that the MSC Server shall:

- initiate a terminating call leg toward the UE in accordance with 3GPP TS 24.008 [3]; and

NOTE: If the user is involved in a call, then the call waiting procedures described in 3GPP TS 24.008 [3] and 3GPP TS 24.083 [26] apply.

- initiate an originating call toward the URI identified in the Refer-To header (e.g. the conference URI); and
- combine these two call legs into a single call.

Support for this method of joining a conference may be provided as an implementation option but is outside the scope of the present document.

5.6.8.3.1.4 Receipt of INVITE

NOTE: Subclause 5.4.2 contains general applicable procedures executed upon receipt of an initial INVITE request.

If an INVITE request is received, the MSC Server shall act as follows:

- if the user is idle, the MSC Server shall act according to the mobile terminating call set up procedures specified in subclause 5.4;
- if the user is engaged in an established SIP dialog and the INVITE request contains a Replaces header field corresponding to the established dialog, the MSC Server act as a transfer target on behalf of the UE as specified in subclause 5.6.7.4; or
- if the user is engaged in an established SIP dialog and the INVITE request does not contain a Replaces header field corresponding to the established dialog, the MSC Server shall follow the communication waiting procedures described in subclause 5.6.4.1.

5.6.8.3.2 Notification of conference invocation

If the MSC Server received a non-zero SS screening indicator from the UE as defined in 3GPP TS 24.080 [29], then upon joining a conference on behalf of a UE, the MSC Server may send a FACILITY message to the UE indicating a multiparty call has been invoked as specified in 3GPP TS 24.084 [34].

NOTE: If the MSC Server was invited to the conference via reception of a REFER request as specified in 3GPP TS 24.147 [36] subclause 5.3.1.5.2, the MSC Server is not able to distinguish between REFER requests for the conferencing service and REFER requests for the ECT service. In such cases, the MSC Server will not know which SS operation to indicate in the FACILITY message. Handling of this scenario is implementation specific.

5.6.9 Customized Alerting Tones (CAT)

5.6.9.1 General

The following subclauses describe the MSC Server interworking behaviour related to the Customized Alerting Tones (CAT) services defined in 3GPP TS 24.182 [51].

Based on operator options, one of three different models described in 3GPP TS 24.182 [51] is used in an IM CN subsystem to provide the CAT service. The CAT interworking procedures at the MSC server differ between these models and are described separately for each model in the subsequent sub-clauses. Support of the interworking procedures for each of those models is optional.

No special interworking procedures for the CAT service when MSC server receive a terminating request from IMS network are required.

5.6.9.2 Early session model

5.6.9.2.1 Originating request

If the MSC server supports early-session as a network option, upon receiving an incoming SETUP message, before the MSC server sending the generated SIP INVITE request as described in subclause 5.3.3, it shall include the option tag "early-session", as defined in IETF RFC 3959 [50], in Supported header field.

After receiving the first SIP 18x response including an early-session SDP, the MSC server shall send the ALERTING message as described in 3GPP TS 24.008 [3], then the MSC server shall follow the same procedure as described for MGCF in 3GPP TS 29.163 subclause 7.5.13 [46] to negotiate with IMS side for early-session and normal session establishment.

5.6.9.3 Forking model

Interworking at MSC server follows the basic call interworking procedures. Support of the P-Early-Media header field and related procedures as described in subclause 5.3.4a and subclause 5.3.4b are required in addition.

5.6.9.4 Gateway model

Interworking at MSC server follows the basic call interworking procedures. Support of the P-Early-Media header field and related procedures as described in subclause 5.3.4a and subclause 5.3.4b are required in addition.

5.6.10 Communication Completion Services (CCBS/CCNL/CCNR)

5.6.10.1 General

The following subclauses describe the MSC Server interworking behaviour related to the Communication Completion services defined in 3GPP TS 24.642 [52] and a UE using CS access domain signalling specified in 3GPP TS 24.093 [53].

5.6.10.2 Communication Completion Terminated at Served User

When the Served User is the terminating user, no special interworking is required at the MSC Server.

5.6.10.3 Communication Completion Originated at Served User

5.6.10.3.1 Actions without 3PCC

When the MSC Server receives a CC Recall as a REFER request as described in 3GPP TS 24.642 [52] subclause 4.5.4.2.3.1, the MSC Server may assign a CCBS Index to this recall if not already done, and may perform the CC Recall procedures as specified by 3GPP TS 24.093 [53]. When the SETUP message is received, normal call handling continues.

If the MSC Server does not support accepting REFER requests on behalf of the UE per operator policy, then the MSC Server shall return a 403 Forbidden response.

5.6.10.3.2 Actions with 3PCC

When 3PCC is used for CCBS/CCNL/CCNR as specified in 3GPP TS 24.642 [52], no special interworking is required at the MSC Server.

5.7 Supplementary Service Configuration

5.7.1 General

The MSC Server may support the interworking between call independent supplementary service signalling described in 3GPP TS 24.010 [41] and the XCAP application usage for manipulating supplementary services data described in 3GPP TS 24.623 [42]. This MSC Server may support this interworking for any subset of the supplementary services within the scope of the present document. This interworking shall only be performed for the TS11 service code. If the MSC Server interworks a supplementary service invoke operation received via NAS signalling to the IM CN subsystem, the MSC Server shall not also transfer the received information to the VLR as described in 3GPP TS 29.002 [20]. This interworking is defined in the following subclauses.

NOTE: This interworking is subject to the limitations inherited by the NAS signalling procedures defined for each supplementary service. For example, if no NAS signalling procedure is defined for registration, erasure, activation, deactivation or interrogation of a particular supplementary service that is being controlled by the IM CN subsystem, then no interworking procedure is defined.

5.7.2 Receipt of REGISTER message

Upon receipt of a REGISTER message for a supplementary service whose interworking is within the scope of the present document, the MSC Server shall generate the appropriate HTTP request according to table 5.7.2.1 if supplementary service configuration interworking for that supplementary service is supported by the MSC Server.

Table 5.7.2.1: Mapping REGISTER / FACILITY to HTTP request

Invoke operation in the REGISTER message	HTTP request
RegisterSS	PUT
ActivateSS	PUT
DeactivateSS	PUT
InterrogateSS	GET
EraseSS	PUT

NOTE: Not all invoke operations are valid for all supplementary services. Interworking definitions for each supplementary service are only provided for invoke operations explicitly defined for each supplementary service.

The interworking of message contents for each supplementary service is described in subclause 5.7.4.

5.7.3 Receipt of HTTP response

Upon receipt of an HTTP response to a previously sent HTTP request as described in subclause 5.7.2, the MSC Server shall terminate the appropriate service interaction by sending a RELEASE COMPLETE message. The interworking of message contents for each supplementary service is described in subclause 5.7.4.

5.7.4 Service data interworking

5.7.4.1 Originating identification presentation/restriction (OIP/OIR)

5.7.4.1.1 Registration/erasure

The OIP/OIR services require no registration. Erasure is not applicable.

5.7.4.1.2 Activation/deactivation

The OIP/OIR services are activated at provisioning and deactivated at withdrawal and therefore require no interworking at the MSC Server.

5.7.4.1.3 Interrogation

If the MSC Server supports supplementary service configuration interworking for the OIP/OIR services, the interworking procedures in this subclause shall be applied.

When the MSC Server receives a REGISTER message with an InterrogateSS invoke operation for the CLIP or CLIR supplementary service code as described in 3GPP TS 24.081 [12], the MSC Server shall generate and send an HTTP GET request to fetch the instance of the Originating Identity document as specified in 3GPP TS 24.623 [42].

Upon receiving a response to the HTTP GET request, the MSC Server shall apply the following interworking:

- If a 200 OK response is received which includes an Originating Identity document as defined in 3GPP TS 24.607 [43], the MSC Server shall send a RELEASE COMPLETE message as follows:
 - If the Originating Identity document indicates the interrogated service (CLIP/OIP or CLIR/OIR) is active, the MSC Server shall indicate an SS-Status of provisioned and active; or
 - If the Originating Identity document indicates the interrogated service (CLIP/OIP or CLIR/OIR) service is not active, the MSC Server shall indicate an SS-Status of provisioned but not active;
 - If the CLIR/OIR service was interrogated, then the following additional interworking shall be applied:
 - If there is a "default-behaviour" attribute included and set to "presentation-restricted" in the Originating Identity document, the MSC Server shall set the CLI Restriction Option parameter to indicate Temporary (Default Restricted);
 - If there is a "default-behaviour" attribute included and set to "presentation-not-restricted" in the Originating Identity document the MSC Server shall set the CLI Restriction Option parameter to Temporary (Default Allowed);
- If a non 200 OK response is received or if a 200 OK response is received which does not include an Originating Identity document, the MSC Server shall send a RELEASE COMPLETE message with an implementation-specific error code.

5.7.4.2 Terminating identification presentation/restriction (TIP/TIR)

5.7.4.2.1 Registration/erasure

The TIP/TIR services require no registration. Erasure is not applicable.

5.7.4.2.2 Activation/deactivation

The TIP/TIR services are activated at provisioning and deactivated at withdrawal and therefore require no interworking at the MSC Server.

5.7.4.2.3 Interrogation

If the MSC Server supports supplementary service configuration interworking for the TIP/TIR services, the interworking procedures in this subclause shall be applied.

When the MSC Server receives a REGISTER message with an InterrogateSS invoke operation for the COLP or COLR supplementary service code as described in 3GPP TS 24.081 [12], the MSC Server shall generate an HTTP GET request to fetch the instance of the Terminating Identity document as specified in 3GPP TS 24.623 [42].

Upon receiving a response to the HTTP GET request, the MSC Server shall apply the following interworking:

- If a 200 OK response is received which includes a Terminating Identity document as defined in 3GPP TS 24.608 [14], the MSC Server shall send a RELEASE COMPLETE message as follows:

- If the Terminating Identity document indicates the interrogated service (COLP/TIP or COLR/TIR) is active, the MSC Server shall indicate an SS-Status of provisioned and active; or
- If the Terminating Identity document indicates the interrogated service (COLP/TIP or COLR/TIR) service is not active, the MSC Server shall indicate an SS-Status of provisioned but not active;

NOTE: CS signalling defined in 3GPP TS 24.081 [12] does not allow for the temporary mode status of the COLR service to be sent to the UE.

- If a non 200 OK response is received or if a 200 OK response is received which does not include a Terminating Identity document, the MSC Server shall send a RELEASE COMPLETE message with an implementation-specific error code.

5.7.4.3 Communication Hold (HOLD)

Configuration of the HOLD service involves no signalling and therefore requires no interworking at the MSC Server.

5.7.4.4 Communication Waiting (CW)

5.7.4.4.1 Registration/erasure

The CW service requires no registration. Erasure is not applicable.

5.7.4.4.2 Activation/deactivation

If the MSC Server supports supplementary service configuration interworking for the CW service, the interworking procedures in this subclause shall be applied.

When the MSC Server receives a REGISTER message with an ActivateSS or DeactivateSS invoke operation for the CW supplementary service code as described in 3GPP TS 24.083 [26], the MSC Server shall include an instance of the call waiting document described in 3GPP TS 24.615 [44] in the HTTP PUT request as follows:

- If the invoke operation is ActivateSS, the MSC Server shall set the "active" attribute to "true";
- If the invoke operation is DeactivateSS, the MSC Server shall set the "active" attribute to "false".

5.7.4.4.3 Interrogation

If the MSC Server supports supplementary service configuration interworking for the CW service, the interworking procedures in this subclause shall be applied.

When the MSC Server receives a REGISTER message with an InterrogateSS invoke operation for the CW supplementary service code as described in 3GPP TS 24.083 [26], the MSC Server shall generate and send an HTTP GET request to fetch the instance of the call waiting document as specified in 3GPP TS 24.623 [42].

When a response to the HTTP GET request is received, the MSC Server shall apply the following interworking:

- If a 200 OK is received which includes a call waiting document as defined in 3GPP TS 24.615 [44], the MSC Server shall send a RELEASE COMPLETE message as follows:
 - If the call waiting document includes an "active" attribute set to "true", the MSC Server shall indicate an SS-Status of provisioned and active;
 - If the call waiting document includes an "active" attribute set to "false", the MSC Server shall indicate an SS-Status of provisioned but not active;
- If a non 200 OK response is received or if a 200 OK response is received which does not include a call waiting document, the MSC Server shall send a RELEASE COMPLETE message with an implementation-specific error code.

5.7.4.5 Communication Barring (CB)

5.7.4.5.1 Registration/erasure

When the MSC Server receives a REGISTER message with a RegisterSS invoke operation for any call barring supplementary service code as described in 3GPP TS 24.088 [30], the MSC Server shall send a RELEASE COMPLETE message with an implementation-specific error code.

NOTE: This is because the password registration procedures required to support CB registration using NAS signalling do not have equivalencies in 3GPP TS 24.623 [42] or 3GPP TS 24.611 [31].

Erasure of the CB service is not specified for NAS signalling in 3GPP TS 24.088 [30], therefore interworking procedures for service erasure are not applicable.

5.7.4.5.2 Activation/deactivation

When the MSC Server receives a REGISTER message with an ActivateSS or DeactivateSS invoke operation for any call barring supplementary service code as described in 3GPP TS 24.088 [30], the MSC Server shall send a RELEASE COMPLETE message with an implementation-specific error code.

NOTE: This is because the password registration procedures required to support CB activation and deactivation using NAS signalling do not have equivalencies in 3GPP TS 24.623 [42] or 3GPP TS 24.611 [31].

5.7.4.5.3 Interrogation

If the MSC Server supports supplementary service configuration interworking for the CB service, the interworking procedures in this subclause shall be applied.

When the MSC Server receives a REGISTER message with an InterrogateSS invoke operation for the BAOC or BAIC supplementary service code as described in 3GPP TS 24.082 [24], the MSC Server shall generate and send an HTTP GET request to fetch the instance of the Communication Barring document as specified in 3GPP TS 24.623 [42].

When a response to the HTTP GET request is received, the MSC Server shall apply the following interworking:

- If a 200 OK response is received which includes a Communication Barring document as defined in 3GPP TS 24.611 [31], the MSC Server shall send a RELEASE COMPLETE message as follows:
 - If the Communication Barring document indicates the call barring service being interrogated is active, the MSC Server shall include a BasicServiceCode set to the TS11 service code;
 - If the Communication Barring document indicates the call barring service being interrogated is not active, the MSC Server shall include an SS-Status of deactivated;
- If a non 200 OK response is received or if a 200 OK response is received which does not include a Communication Barring document, the MSC Server shall send a RELEASE COMPLETE message with an implementation-specific error code.

When the MSC Server receives a REGISTER message with an InterrogateSS invoke operation for the BOIC, BOIC-exHC or BIC-Roam supplementary service code as described in 3GPP TS 24.082 [24], the MSC Server shall send a RELEASE COMPLETE message with an implementation-specific error code as these supplementary service codes cannot be mapped to the CB rules defined in 3GPP TS 24.611 [31].

5.7.4.6 Communication Diversion (CDIV)

5.7.4.6.1 Registration

If the MSC Server supports supplementary service configuration interworking for the CDIV service, the interworking procedures in this subclause shall be applied.

When the MSC Server receives a REGISTER message with a RegisterSS invoke operation for a supplementary service code listed below, the MSC Server shall include Communication Diversion document as described in 3GPP TS 24.604 [23] in the HTTP PUT request as follows:

- The MSC Server shall set the active attribute to "true";
- If the supplementary service code is CFU as described in 3GPP TS 24.082 [24], the MSC Server shall include an empty rule set;
- If the supplementary service code is CFB as described in 3GPP TS 24.082 [24], the MSC Server shall include a forwarding rule for the busy condition defined in 3GPP TS 24.604 [23];
- If the supplementary service code is CFNRy as described in 3GPP TS 24.082 [24], the MSC Server shall include a forwarding rule for the no-answer condition defined in 3GPP TS 24.604 [23];
- If the supplementary service code is CFNRc as described in 3GPP TS 24.082 [24], the MSC Server shall include a forwarding rule for the not-reachable condition defined in 3GPP TS 24.604 [23];
- The MSC Server shall include a "target" element set to the TEL URI representation of the ForwardedToNumber parameter received in the REGISTER message. The TEL URI shall be constructed as described in subclause 5.3.3.2.

NOTE: The Communication Diversion document described in 3GPP TS 24.604 [23] defines XML elements which have no functional equivalent in the service configuration signalling defined in 3GPP TS 24.082 [24]. The inclusion of these elements and the values assigned to them is subject to operator policy.

The MSC Server shall store a copy of the Communication Diversion document until the HTTP PUT response is received and processed.

When a response to the HTTP PUT request is received, the MSC Server shall apply the following interworking:

- If a 200 OK is received, the MSC Server shall send a RELEASE COMPLETE message as follows:
 - The MSC Server shall indicate an SS-Status of provisioned and active;
 - The MSC Server shall set the ForwardedToNumber parameter to the "target" element in the stored Communication Diversion document.
- If a non 200 OK response is received or if a 200 OK response is received which does not include a Communication Diversion document, the MSC Server shall send a RELEASE COMPLETE message with an implementation-specific error code.

5.7.4.6.1a Erasure

If the MSC Server supports supplementary service configuration interworking for the CDIV service, the interworking procedures in this subclause shall be applied.

When the MSC Server receives a REGISTER message with an EraseSS invoke operation for a supplementary service listed below, the MSC Server shall first fetch the instance of the Communication Diversion document as described in subclause 5.7.4.6.3. If the MSC Server is unable to fetch the Communication Diversion document, the MSC Server shall send a RELEASE COMPLETE message with an implementation-specific error code.

The MSC Server shall then include the Communication Diversion document as described in 3GPP TS 24.604 [23] in an HTTP PUT request, modified as follows:

- If the supplementary service code is CFU, the MSC Server shall remove the empty rule set, if present;
- If the supplementary service code is CFB, the MSC Server shall remove the forwarding rule for the busy condition defined in 3GPP TS 24.604 [23], if present;
- If the supplementary service code is CFNRy, the MSC Server shall remove the forwarding rule for the no-answer condition defined in 3GPP TS 24.604 [23], if present;
- If the supplementary service code is CFNRc, the MSC Server shall remove the forwarding rule for the not-reachable condition defined in 3GPP TS 24.604 [23], if present;
- If the supplementary service code is "all forwarding SS", the MSC Server shall remove all forwarding rules described above.

When a response to the HTTP PUT request is received, the MSC Server shall apply the following interworking:

- If a 200 OK is received, the MSC Server shall send a RELEASE COMPLETE message as follows:
 - If an SS-Status parameter is required as specified in 3GPP TS 24.082 [24] subclause 1.3.1, the MSC Server shall indicate an SS-Status of not active;
- If a non 200 OK response is received or if a 200 OK response is received which does not include a Communication Diversion document, the MSC Server shall send a RELEASE COMPLETE message with an implementation-specific error code.

5.7.4.6.2 Activation/deactivation

If the MSC Server supports supplementary service configuration interworking for the CDIV service, the interworking procedures in this subclause shall be applied.

When the MSC Server receives a REGISTER message with an ActivateSS or DeactivateSS invoke operation for the CFU, CFB, CFNRy or CFNRc supplementary service code as described in 3GPP TS 24.082 [24], the MSC Server shall include a Communication Diversion document as described in 3GPP TS 24.604 [23] in the HTTP PUT request as follows:

- If the invoke operation is ActivateSS, the MSC Server shall set the "active" attribute to "true";
- If the invoke operation is DeactivateSS, the MSC Server shall set the "active" attribute to "false";
- If the supplementary service code is CFU as described in 3GPP TS 24.082 [24], the MSC Server shall include an empty rule set;
- If the supplementary service code is CFB as described in 3GPP TS 24.082 [24], the MSC Server shall include a forwarding rule for the busy condition defined in 3GPP TS 24.604 [23];
- If the supplementary service code is CFNRy as described in 3GPP TS 24.082 [24], the MSC Server shall include a forwarding rule for the no-answer condition defined in 3GPP TS 24.604 [23];
- If the supplementary service code is CFNRc as described in 3GPP TS 24.082 [24], the MSC Server shall include a forwarding rule for the not-reachable condition defined in 3GPP TS 24.604 [23];

NOTE: The Communication Diversion document described in 3GPP TS 24.604 [23] defines XML elements which have no functional equivalent in the service configuration signalling defined in 3GPP TS 24.082 [24]. The inclusion of these elements and the values assigned to them is subject to operator policy.

The MSC Server shall store a copy of the Communication Diversion document until the HTTP PUT response is received and processed.

When a response to the HTTP PUT request is received, the MSC Server shall apply the following interworking:

- If a 200 OK is received, the MSC Server shall send a RELEASE COMPLETE message as follows:
 - If the "active" attribute in the stored Communication Diversion document is set to "true", the MSC Server shall indicate an SS-Status of provisioned and active;
 - If the "active" attribute in the stored Communication Diversion document is set to "false", the MSC Server shall indicate an SS-Status of provisioned but not active;
- If a non 200 OK response is received or if a 200 OK response is received which does not include a Communication Diversion document, the MSC Server shall send a RELEASE COMPLETE message with an implementation-specific error code.

5.7.4.6.3 Interrogation

If the MSC Server supports supplementary service configuration interworking for the CDIV service, the interworking procedures in this subclause shall be applied.

When the MSC Server receives a REGISTER message with an InterrogateSS invoke operation for the CFU, CFB, CFNRy or CFNRc supplementary service code as described in 3GPP TS 24.082 [24], the MSC Server shall generate and send an HTTP GET request to fetch the instance of the Communication Diversion document as specified in 3GPP TS 24.604 [23].

When a response to the HTTP GET request is received, the MSC Server shall apply the following interworking:

- If a 200 OK is received which includes a Communication Diversion document as defined in 3GPP TS 24.604 [23], the MSC Server shall send a RELEASE COMPLETE message as follows:
 - If the Communication Diversion document indicates the call forwarding service being interrogated is active, the MSC Server shall indicate an SS-Status of provisioned and active;
 - If the Communication Diversion document indicates the call forwarding service being interrogated is not active, the MSC Server shall indicate an SS-Status of provisioned but not active;
 - If the Communication Diversion document contains a "target" attribute containing a TEL URI, the MSC Server shall set the ForwardedToNumber parameter to the TEL URI.
- If a non 200 OK response is received or if a 200 OK response is received which does not include a Communication Diversion document, the MSC Server shall send a RELEASE COMPLETE message with an implementation-specific error code.

5.7.4.7 Explicit Communication Transfer (ECT)

Configuration of the ECT service involves no signalling and therefore requires no interworking at the MSC Server.

5.7.4.8 Conference (CONF)

Configuration of the CONF service involves no signalling and therefore requires no interworking at the MSC Server.

5.7.4.9 Communication Completion Services (CCBS/CCNL/CCNR)

5.7.4.9.1 Activation/deactivation

Activation in the IMS network as specified in 3GPP TS 24.642 [52] is performed using announcement procedures and inband interaction and no special interworking is needed.

If the MSC Server supports interworking of deactivating all outstanding CCBS requests, the MSC Server shall upon receipt of a REGISTER message with a Deactivate all CCBS Requests Invoke operation revoke all outstanding CCBS requests using the methods in 3GPP TS 24.642 [52].

If the MSC receives a REGISTER message with a Deactivate specific CCBS Request the MSC Server shall if no interworking is supported respond with a RELEASE COMPLETE message with an implementation specific error code.

5.7.4.9.2 Interrogation

If the MSC Server supports supplementary service configuration interworking for the CCBS service, the interworking procedures in this subclause shall be applied.

When the MSC Server receives a REGISTER message with an InterrogateSS invoke operation for the CCBS supplementary service code as described in 3GPP TS 24.093 [53], the MSC Server shall generate and send an HTTP GET request to fetch the instance of the Communication Completion document as specified in 3GPP TS 24.642 [52].

When an HTTP 200 OK response is received which includes a Communication Completion document as defined in 3GPP TS 24.642 [52], the MSC Server shall:

- 1) if the Communication Completion document indicates the call forwarding service being interrogated is active generate an HTTP GET request to fetch an instance of the Communication Completion Request Records document as defined in 3GPP TS 24.642 [52];

when a response to the HTTP GET request is received the MSC server shall:

- a) if an HTTP 200 OK is received which includes a Communication Completion Request Records document as defined in 3GPP TS 24.642 [52] where there is one or more instances of the "cc-entry" element, assign to each of these elements a CCBS Index and send a RELEASE COMPLETE message indicating an SS-Status of provisioned and include the list of outstanding CCBS requests; and

- b) if an HTTP non 200 OK response is received or if there are no instances of the "cc-entry" element, send a RELEASE COMPLETE message indicating an SS-status set to "provisioned", but there are no outstanding requests; and
- 2) if the Communication Completion document indicates the communication completion service being interrogated is not active, send a RELEASE COMPLETE message indicating an SS-Status of not provisioned.

When an HTTP non 200 OK response is received or if an HTTP 200 OK response is received which does not include a Communication Completion document, the MSC Server shall send a RELEASE COMPLETE message with an implementation-specific error code.

5.8 Handover / Relocation

5.8.1 Intra-MSC Handover/Relocation

The MSC Server applies the procedures specified in 3GPP TS 23.009 [37] for Intra-MSC handover/relocation in the CS domain. After the handover/relocation is completed, the MSC Server shall process the interworking between the NAS signalling with the SIP signalling as specified in sub-clauses 5.3 through 5.6.

5.8.2 Inter-MSC Handover/Relocation

The MSC Server applies the procedures specified in 3GPP TS 23.009 [37] for Inter-MSC handover/relocation in the CS domain. After the handover/relocation is completed, the anchor MSC Server shall process the interworking between the NAS signalling with the SIP signalling as specified in sub-clauses 5.3 through 5.6. The NAS signalling contained in the MAP messages is passed between the anchored MSC Server and the target MSC Server through the E interface as specified in 3GPP TS 29.002 [20].

6 User plane interworking

6.1 General

The following subclauses define the interworking performed by the CS-MGW between the IM CN subsystem and CS domain access. The interworking between the Mb reference point and the user plane portions of the IuCS and A reference points is specified.

6.2 IuCS to Mb interworking

6.2.1 Interworking with transcoding

Figure 6.2.1.1 shows the user plane protocol stacks for the IuCS and IM CN subsystem interworking when transcoding is required.

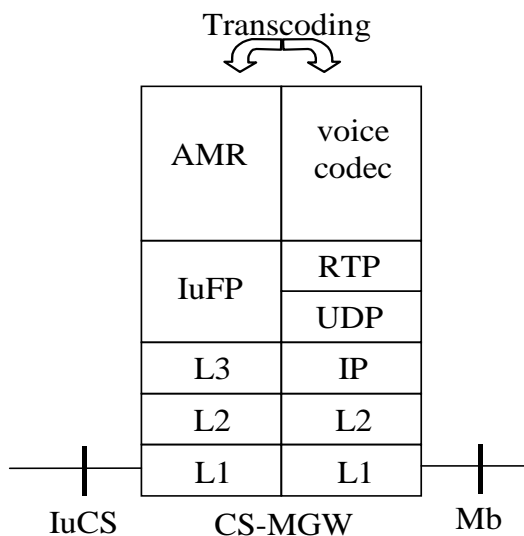

Figure 6.2.1.1: IuCS to Mb protocol stack (transcoding)

IuFP is defined in 3GPP TS 25.415 [16]. IuCS layer 2 and layer 3 are defined in 3GPP TS 25.414 [15]. The IuCS layer 1 is defined in 3GPP TS 25.411 [17].

6.2.2 Transcoder-less interworking

Figure 6.2.2.1 shows the user plane protocol stacks for the interworking when the same AMR configuration is used on the IuCS and Mb reference points and transcoding is not required.

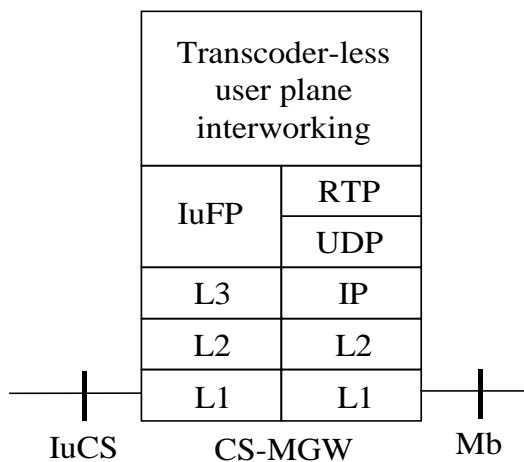

Figure 6.2.2.1: IuCS to Mb protocol stack (no transcoding)

If no transcoder is inserted, the CS-MGW shall interwork procedures between the IuCS and Mb reference points as specified in 3GPP TS 29.414 [18] subclause 7.4.

6.3 TDM-based A-interface to Mb interworking

6.3.1 Interworking with transcoding

Figure 6.3.1.1 shows the user plane protocol stacks for the TDM-based A and Mb reference point interworking when transcoding is required.

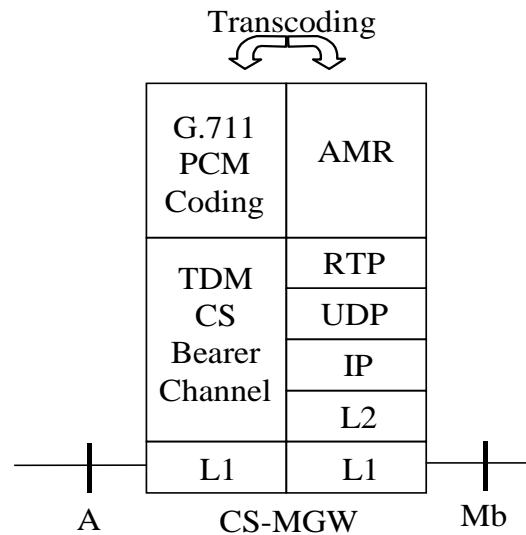

Figure 6.3.1.1: TDM-based A to Mb protocol stack (transcoding)

Layer 1 for the TDM-based A-interface is defined in 3GPP TS 48.004 [19].

6.3.2 Transcoder-less interworking

Figure 6.3.2.1 shows the user plane protocol stacks for the interworking when the same codec is used on the TDM-based A and Mb reference points and transcoding is not required.

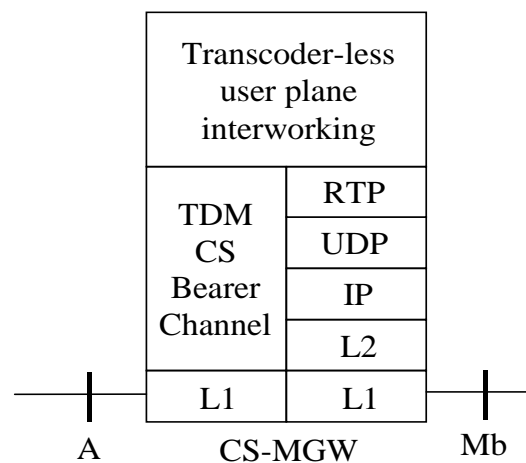

Figure 6.3.2.1: TDM-based A to Mb protocol stack (no transcoding)

6.4 IP-based A-interface to Mb interworking

6.4.1 Interworking with transcoding

Figure 6.4.1.1 shows the user plane protocol stacks for the IP-based A and Mb reference point interworking when transcoding is required.

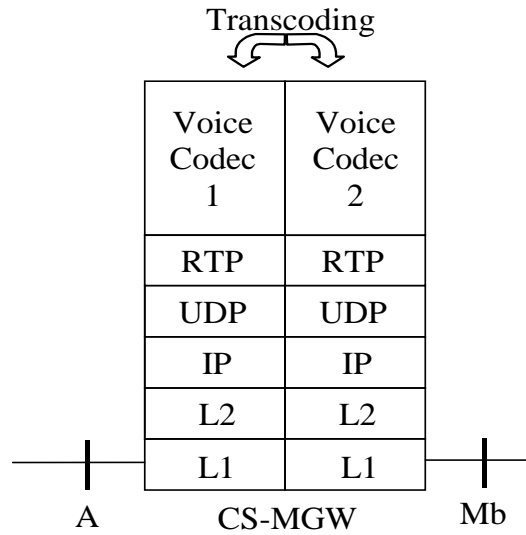

Figure 6.4.1.1: IP-based A to Mb protocol stack (transcoding)

The IP-based A-interface user plane transport is defined in 3GPP TS 48.103 [38].

6.4.2 Transcoder-less interworking

Figure 6.4.2.1 shows the user plane protocol stacks for the interworking when the same codec is used on the IP-based A and Mb reference points and transcoding is not required.

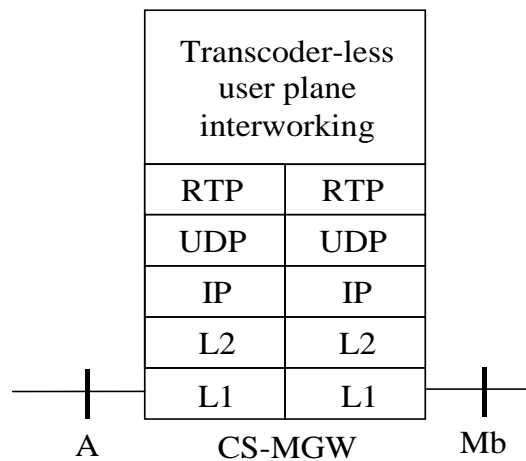

Figure 6.4.2.1: IP-based A to Mb protocol stack (no transcoding)

The IP-based A-interface user plane transport is defined in 3GPP TS 48.103 [38].

7 MSC Server – CS-MGW interaction

7.1 Mobile originated call

7.1.1 CS-MGW selection

The MSC Server shall select a CS-MGW for the bearer connection before it performs the access bearer assignment or the network side connection point reservation.

7.1.2 IMS session side establishment

The MSC Server shall either select bearer characteristics or request the CS-MGW to select and provide the bearer characteristics for the network side session before sending the INVITE request. The MSC Server shall use the Reserve RTP Connection Point procedure as defined in 3GPP TS 29.232 [11].

Within this procedure, the MSC Server shall indicate the received speech codecs from the UE and the MSC Server may indicate some configured speech codec(s) to the CS-MGW and request a local IP address and UDP port from the CS-MGW and the MSC Server may also indicate that the IP interface type is for MboIP as defined in 3GPP TS 29.232 [11]. The local IP address and UDP port are used by the CS-MGW to receive user plane data.

The CS-MGW shall reply to the MSC Server with the selected local speech codec(s) and the selected local IP address and UDP port(s).

After the succeeding node has provided the SDP answer, the MSC Server uses the Configure RTP Resources procedure as defined in 3GPP TS 29.232 [11] to request the CS-MGW to configure the bearer.

7.1.3 Access bearer establishment

7.1.3.1 General

The way the MSC Server media gateway interaction is carried out depends on the characteristics of the access bearer network.

7.1.3.2 Iu interface on IP

The MSC Server and the CS-MGW shall act in accordance with subclause 6.1.3 in 3GPP TS 23.205 [39] and apply the coding in accordance with 3GPP TS 29.232 [11].

7.1.3.3 A interface over IP

The MSC Server and the CS-MGW shall act in accordance with subclause 6.1.5 in 3GPP TS 23.205 [39] and apply the coding in accordance with 3GPP TS 29.232 [11].

7.1.3.4 A interface over TDM

The MSC Server and the CS-MGW shall act in accordance with subclause 6.1.1.4 in 3GPP TS 23.205 [39] and apply the coding in accordance with 3GPP TS 29.232 [11].

7.1.3.5 Iu over UTRAN and GERAN

The MSC Server and the CS-MGW shall act in accordance with subclause 6.1.1.4 in 3GPP TS 23.205 [39] and apply the coding in accordance with 3GPP TS 29.232 [11].

7.1.4 Apply ringing tone

If the condition as defined in subclause 5.3.5 is fulfilled the MSC Server shall instruct the CS-MGW to send ringing tone towards the calling party. In this case the MSC Server shall use the Send Tone procedure in accordance with 3GPP TS 23.205 [39] and 3GPP TS 29.232 [11].

If the MSC Server wishes to stop sending the ringing tone e.g. due to the receipt of a 200 OK response to the INVITE request the MSC Server shall apply the Stop Tone procedure as defined in 3GPP TS 23.205 [39] and 3GPP TS 29.232 [11].

7.1.5 Through connection

If the MSC Server wants to configure the CS-MGW so that the bearer will be through-connected in the backward direction the MSC Server shall:

- use Change Through-Connection procedure as defined in 3GPP TS 29.232 [11] during any one of the Prepare Bearer and Reserve Circuit procedures as defined in 3GPP TS 29.232 [11]; or
- use Configure the RTP Connection Point procedure as defined in 3GPP TS 29.232 [11] during Prepare IP bearer procedure as defined in 3GPP TS 29.232 [11].

If the MSC Server wants to configure the CS-MGW so that the bearer will be both-way through connected the MSC Server shall use Change Through-Connection procedure as defined in 3GPP TS 29.232 [11].

7.1.5a Handling of Forking

The procedures described in subclauses 7.1.1 to 7.1.6 shall be applied with the addition that the MSC Server and the CS-MGW shall act in accordance with subclauses 9.2.3.4.1 to 9.2.3.4.4 in 3GPP TS 29.163 [46].

NOTE: For the references to 3GPP TS 29.163 [46], the O-MGCF and I-MGCF in 3GPP TS 29.163 [46] is to be understood as MSC Server, the IM-MGW is to be understood as CS-MGW, and the Configure IMS Resources procedure is to be understood as Configure RTP Resources procedure.

7.1.6 Failure handling in MSC server

If any procedure between the MSC Server and the CS-MGW has not completed successfully or the MSC Server receives a Bearer Released procedure from the CS-MGW the procedure in accordance with subclause 6.1.1.12 of 3GPP TS 23.231 [40] and 3GPP TS 29.232 [11] shall be applied.

7.2 Mobile terminated call

7.2.1 CS-MGW selection

The MSC Server shall select an CS-MGW for the bearer connection before it performs the network side bearer establishment or the access bearer assignment. The selection of the CS-MGW does not take place before the call proceeding has been received by the MSC Server.

7.2.2 Network side session establishment

The MSC Server shall request the CS-MGW to prepare for the network side session establishment using the Reserve RTP Connection Point and Configure RTP Resources procedure as specified in 3GPP TS 23.205 [39] and 3GPP TS 29.232 [11]. Within this procedure, the MSC Server shall indicate the received speech codecs from the remote UE and request a local IP address and UDP port from the CS-MGW and the MSC Server may also indicate that the IP interface type is for MboIP as defined in 3GPP TS 29.232 [11]. The local IP address and UDP ports are used by the CS-MGW to receive user plane data. The MSC Server shall include the local IP address and UDP port number in the SDP answer for the selected codec.

7.2.3 Access bearer assignment

7.2.3.1 General

The way the MSC Server-CS-MGW interaction is carried out depends on the characteristics of the access bearer network.

7.2.3.2 Iu interface on IP

The MSC Server and the CS-MGW shall act in accordance with subclause 6.2.3 in 3GPP TS 23.205 [39] and apply the coding in accordance with 3GPP TS 29.232 [11].

7.2.3.3 A interface over IP

The MSC Server and the CS-MGW shall act in accordance with subclause 6.2.4 in 3GPP TS 23.205 [39] and apply the coding in accordance with 3GPP TS 29.232 [11].

7.2.3.4 A interface over TDM

The MSC Server and the CS-MGW shall act in accordance with subclause 6.2.2.2.4 in 3GPP TS 23.205 [39] and apply the coding in accordance with 3GPP TS 29.232 [11].

7.2.3.5 Iu over UTRAN and GERAN

The MSC Server and the CS-MGW shall act in accordance with subclause 6.2.2.2.4 in 3GPP TS 23.205 [39] and apply the coding in accordance with 3GPP TS 29.232 [11].

7.2.4 Apply ringing tone

If the condition as defined in subclause 5.4.7 is fulfilled the MSC Server shall instruct the CS-MGW to send ringing tone towards the calling party. In this case the MSC Server shall use the Send Tone procedure in accordance with 3GPP TS 23.205 [39] and 3GPP TS 29.232 [11].

If the MSC Server wishes to stop sending the ringing tone, e.g. due to receipt of the CONNECT message, the MSC Server shall apply the Stop Tone procedure as defined in 3GPP TS 23.205 [39] and 3GPP TS 29.232 [11].

7.2.5 Through connection

If the MSC Server wants to configure the CS-MGW so that the bearer will not be through-connected the MSC Server shall:

- use Change Through-Connection procedure as defined in 3GPP TS 29.232 [11] during any one of the Prepare Bearer and Reserve Circuit procedures as defined in TS 3GPP 29.232 [11]; or
- use Configure the RTP Connection Point procedure as defined in 3GPP TS 29.232 [11] during Prepare IP bearer procedure as defined in 3GPP TS 29.232 [11].

If the MSC Server wants to configure the CS-MGW so that the bearer will be both-way through connected the MSC Server shall use the Change Through-Connection procedure as defined in 3GPP TS 29.232 [11].

7.2.6 Announcement

If the MSC Server wants to provide an announcement, e.g. when the condition in subclause 5.4.7 is fulfilled, the MSC Server shall instruct the CS-MGW to send an announcement. In this case the MSC Server shall use the Play Announcement procedure in accordance with 3GPP TS 23.205 [39] and 3GPP TS 29.232 [11].

If the MSC Server wishes to stop the sending of an announcement the MSC Server shall apply the Stop Announcement procedure as defined in 3GPP TS 23.205 [39] and 3GPP TS 29.232 [11].

7.2.7 Failure handling in the MSC server

If any procedure between the MSC Server and the CS-MGW has not completed successfully or the MSC Server receives a Bearer Released procedure from the CS-MGW the procedure in accordance with subclause 6.2.1.3.13 of 3GPP TS 23.231 [40] and 3GPP TS 29.232 [11] shall be applied.

7.3 Call clearing

7.3.1 Clearing received from the network

7.3.1.1 Access bearer clearing

Once the call clearing and the release of the associated radio resources have been completed, the MSC Server releases any CS-MGW allocated resources for the access side. If any resources were seized in the CS-MGW, the MSC Server uses the Release Termination procedure as specified in 3GPP TS 29.232 [11] to request the CS-MGW to remove the access side bearer termination.

7.3.1.2 Network side clearing

If the MSC Server requires to release resources due to the receipt of a BYE or CANCEL request or a response including a failure indication from the network the MSC Server shall act in accordance with subclause 7.2.6 in 3GPP TS 23.231 [40] and 3GPP TS 29.232 [11].

7.3.2 Clearing received from the user

7.3.2.1 Access bearer clearing

Once the call clearing and the release of the associated radio resources have been completed, the MSC Server releases any CS-MGW allocated resources for the access side. If any resources were seized in the CS-MGW, the MSC Server uses the Release Termination procedure as specified in 3GPP TS 29.232 [11] to request the CS-MGW to remove the access side bearer termination.

7.3.2.2 Network side clearing

If the MSC Server requires to release resources due to the receipt of a BYE or CANCEL request or a response including a failure indication from the originating or terminating UE the MSC Server shall act in accordance with subclause 7.2.6 in 3GPP TS 23.231[40] and 3GPP TS 29.232 [11].

7.3.3 Call clearing received from the CS-MGW

7.3.3.1 Bearer released received on the access side

After the MSC Server has received the Bearer Released procedure from the CS-MGW on the access side, the MSC Server shall release the access resources as described in 3GPP TS 24.008 [3]. If the call is already established towards the network side, call clearing to the network side is performed as described in subclause 5.5.3.

7.3.3.2 Bearer released received on the network side

After the MSC Server has received the Bearer Released procedure from the CS-MGW on the network side, the MSC Server shall clear the call to the network side as described in subclause 5.5.3 and clear the call to the UE as described in 3GPP TS 24.008 [3].

7.4 Call independent procedures

The MSC Server and the CS-MGW are involved in a number of procedures which are not related to the setting up and clearing of calls. The MSC Server and the CS-MGW shall comply with the requirements stated in the different subclauses 10.1 - 10.10 of 3GPP TS 23.205 [39] and subclauses 10.12 - 10.16 of 3GPP TS 23.205 [39].

7.5 Explicit Congestion Notification

An MSC Server and a CS-MGW may support Multimedia Telephony using Explicit Congestion Notification (see IETF RFC 3168 [48], IETF RFC 6679 [49], and 3GPP TS 26.114 [28]), and may then act as an ECN endpoint to enable ECN with a local ECN-capable terminal within a local network that properly handles ECN-marked packets.

The ECN procedures described in 3GPP TS 29.163 [46], subclause 9.2.11, for MGCF and IM-MGW are then applicable for MSC Server and the CS-MGW.

7.6 Multimedia Priority Service (MPS) Support

The Multimedia Priority Service (MPS) is specified in 3GPP TS 22.153 [54]. An MSC Server and a CS-MGW may support the priority treatment of a call/session identified as an MPS call/session.

The MPS procedures described in 3GPP TS 29.163 [46], subclause 9.4, for MGCF and IM-MGW are then applicable for MSC Server and the CS-MGW.

Annex A (informative): Change history

Change history							
Date	TSG #	TSG Doc.	CR	Rev	Subject/Comment	Old	New
26/11/08					v2.0.0 was produced by MCC for Approval in CT#42	1.2.0	2.0.0
13/12/08	TSG#42				v8.0.0 was produced by MCC	2.0.0	8.0.0
03/2009	TSG#43	CP-090090	001	2	Removal of stage 2 duplication in Initial Registration specification	8.0.0	8.1.0
03/2009	TSG#43	CP-090090	002	1	Removal of editor's note in clause 7 (MSC-MGW procedures)	8.0.0	8.1.0
03/2009	TSG#43	CP-090090	003	2	Removal of editor's note for INVITE handling	8.0.0	8.1.0
03/2009	TSG#43	CP-090090	004	1	Removal of editor's note for XCAP client procedures at MSC Server enhanced for ICS	8.0.0	8.1.0
03/2009	TSG#43	CP-090090	005	1	CDIV configuration Erasure interworking	8.0.0	8.1.0
03/2009	TSG#43	CP-090090	006	1	CB configuration – Interworking	8.0.0	8.1.0
03/2009	TSG#43	CP-090090	007	2	Handling of Forking	8.0.0	8.1.0
03/2009	TSG#43	CP-090090	008	2	Editorial corrections to TS 29.292	8.0.0	8.1.0
03/2009	TSG#43	CP-090090	009	2	Corrections to TS 29.292	8.0.0	8.1.0
03/2009	TSG#43	CP-090090	010	1	Reference errors and missing abbreviations	8.0.0	8.1.0
03/2009	TSG#43	CP-090090	011	1	CDIV XML document name correction	8.0.0	8.1.0
03/2009	TSG#43	CP-090090	012	1	Correction for MSC server enhanced for ICS procedures	8.0.0	8.1.0
05/2009	TSG#44	CP-090345	014	2	Align XML Schema for CW indication	8.1.0	8.2.0
05/2009	TSG#44	CP-090345	015	2	Authorization of early media	8.1.0	8.2.0
05/2009	TSG#44	CP-090345	016	1	Corrections on Cause Values	8.1.0	8.2.0
09/2009	TSG#45	CP-090578	017	4	IMSI attach	8.2.0	8.3.0
09/2009	TSG#45	CP-090578	018		Correcting erroneous location in subclauses 5.3.8, 5.4.8.2 and 5.6.4.5	8.2.0	8.3.0
09/2009	TSG#45	CP-090578	021		CW Stopping the timer TUE-CW when accepting the waiting call clarification in subclause 5.6.4.2	8.2.0	8.3.0
09/2009	TSG#45	CP-090578	022	1	Aligning with 24.615	8.2.0	8.3.0
12/2009	TSG#46	CP-090847	023		Missing P-Asserted-Identity/Privacy combination on terminating side (OIP)	8.3.0	8.4.0
12/2009	TSG#46	CP-090847	024	6	CW and NDUB interaction added	8.3.0	8.4.0
12/2009	TSG#46	CP-090847	025		Correct incorrect subclause reference	8.3.0	8.4.0
12/2009	TSG#46				Automatic upgrade from previous Release	8.4.0	9.0.0
03/2011	TSG#51	CP-110119	030	1	ECN	9.0.0	10.0.0
03/2011	TSG#51				Correction of typo made by MCC	10.0.0	10.0.1
06/2011	TSG#52	CP-110398	034	3	P-early-media handling at MSC server when sending ALERTING message	10.0.1	10.1.0
06/2011	TSG#52	CP-110414	035	2	Adding the Interworking procedure for supplementary service CAT	10.0.1	10.1.0
06/2011	TSG#52	CP-110412	036	1	Adding the interworking procedures for forking and gateway model for CAT service	10.0.1	10.1.0
09/2011	TSG#53	CP-110626	037	1	Addition of Anonymous Call Rejection in the CS domain	10.1.0	11.0.0
03/2012	TSG#55	CP-120065	039		Reference update: draft-ietf-avtcore-ecn-for-rtp	11.0.0	11.1.0
03/2012	TSG#53	CP-120069	040	3	CCxx services in ICS	11.0.0	11.1.0
06/2012	TSG#56	CP-120334	044	2	S-CSCF restoration procedures	11.1.0	11.2.0
06/2012	TSG#56	CP-120344	048	1	Reference update: draft-ietf-avtcore-ecn-for-rtp	11.1.0	11.2.0
06/2012	TSG#56	CP-120334	052	1	P-Charging-Vector needed in MSC server	11.1.0	11.2.0
09/2012	TSG#57	CP-120533	053	1	eMPs	11.2.0	11.3.0
12/2012	TSG#58	CP-120843	058	1	IMSI detach in MSC Server	11.3.0	11.4.0
12/2012	TSG#58	CP-120828	060		Reference update: RFC 6679	11.3.0	11.4.0
03/2013	TSG#59	CP-130063	065	1	Correction of History-Info interworking	11.4.0	11.5.0
06/2013	TSG#60	CP-130313	082		Mapping of cause value 21 "call rejected"	11.5.0	11.6.0