

3GPP TS 29.235 V11.3.0 (2013-09)

Technical Specification

3rd Generation Partnership Project; Technical Specification Group Core Network and Terminals; Interworking between SIP-I based circuit-switched core network and other networks (Release 11)



The present document has been developed within the 3rd Generation Partnership Project (3GPPTM) and may be further elaborated for the purposes of 3GPP.

The present document has not been subject to any approval process by the 3GPP Organizational Partners and shall not be implemented. This Specification is provided for future development work within 3GPP only. The Organizational Partners accept no liability for any use of this Specification. Specifications and reports for implementation of the 3GPPTM system should be obtained via the 3GPP Organizational Partners' Publications Offices.

Keywords

LTE,

3GPP

Postal address

3GPP support office address650 Route des Lucioles - Sophia Antipolis
Valbonne - FRANCE

Tel.: +33 4 92 94 42 00 Fax: +33 4 93 65 47 16

Internet<http://www.3gpp.org>

Copyright Notification

No part may be reproduced except as authorized by written permission.
The copyright and the foregoing restriction extend to reproduction in all media.

© 2013, 3GPP Organizational Partners (ARIB, ATIS, CCSA, ETSI, TTA, TTC).
All rights reserved.

UMTS™ is a Trade Mark of ETSI registered for the benefit of its members
3GPP™ is a Trade Mark of ETSI registered for the benefit of its Members and of the 3GPP Organizational Partners
LTE™ is a Trade Mark of ETSI currently being registered for the benefit of its Members and of the 3GPP Organizational Partners
GSM® and the GSM logo are registered and owned by the GSM Association

Contents

Foreword	9
1 Scope	10
2 References.....	10
3 Definitions, symbols and abbreviations	12
3.1 Definitions	12
3.2 Abbreviations	12
4 Interworking between a SIP-I based circuit-switched core network and an external SIP-I based network	13
4.1 Reference Model.....	13
4.2 Signalling Interworking of a Call from the external SIP-I based network towards the SIP-I based circuit-switched core network	14
4.2.1 Interworking of SIP-I messages received from external SIP-I network	14
4.2.1.1 General.....	14
4.2.1.2 Call Release from external SIP-I network when encapsulated REL is missing.....	14
4.2.2 Special Procedures for the reception of initial SIP INVITE requests	14
4.2.2.1 Receipt of SIP INVITE request.....	14
4.2.2.2 Receipt of SIP INVITE requests with SDP	15
4.2.2.3 Receipt of SIP INVITE request without SDP	15
4.2.2.4 MGW Selection.....	15
4.2.3 Interworking of SIP-I messages received from succeeding 3GPP node.....	15
4.2.4 Special Procedures for Profile Interworking	15
4.2.4.1 Support of 100Rel.....	15
4.2.4.2 Support for UPDATE method	16
4.2.4.3 Support for Preconditions	16
4.2.5 Support for Codec Negotiation	16
4.2.6 Special Procedures for the reception of SIP Re-INVITE requests	17
4.2.6.1 Receipt of SIP Re-INVITE request without SDP	17
4.3 Signalling Interworking of a Call from SIP-I based circuit-switched core network towards the external SIP-I based network	17
4.3.1 Interworking of SIP-I messages received from preceding 3GPP node.....	17
4.3.1.1 General.....	17
4.3.1.2 Call Release from external SIP-I network when encapsulated REL is missing.....	17
4.3.2 Special Procedures for the reception of SIP INVITE requests.....	17
4.3.3 Special Procedures for Profile Interworking	18
4.3.3.1 Support of 100Rel.....	18
4.3.3.2 Support for UPDATE method	18
4.3.3.3 Support for Preconditions	18
4.3.4 Support for Codec Negotiation	20
4.3.5 MGW Selection	20
4.4 DMTF Signalling Interworking applicable for all Calls between an external SIP-I based network and a SIP-I based circuit-switched core network.....	20
4.4.1 General	20
4.4.2 DTMF support in SDP offer sent to External SIP-I network	20
4.4.3 DTMF support in SDP offer received from External SIP-I network	21
4.5 User Plane Interworking.....	22
4.5.1 General	22
4.5.2 DTMF Interworking	22
4.6 Example Call flows	23
4.6.1 General.....	23
4.6.2 Incoming Call flows	23
4.6.2.1 Incoming Call – no preconditions in external network	23
4.6.2.2 Incoming Call with preconditions not met	25
4.6.3 Outgoing Call flows.....	27
4.6.3.1 Outgoing Call with support for preconditions	27

4.6.3.2	Outgoing Call with support of 100rel but no support for preconditions	29
4.6.3.3	Outgoing Call without support for 100rel and preconditions.....	31
5	Interworking between a SIP-I based circuit-switched core network and an ISUP based network.....	33
5.1	Reference Model.....	33
5.2	Control Plane Interworking	33
5.3	Signalling Interworking of a Call from the ISUP based network towards the SIP-I based circuit-switched core network.....	35
5.3.1	General.....	35
5.3.1.1	Sending of ISUP information to adjacent SIP nodes	35
5.3.1.2	Receipt of encapsulated ISUP information within SIP-I	35
5.3.1.3	Special procedures related to outgoing INVITE	36
5.3.1.3.1	Overlap Signalling.....	36
5.3.1.3.2	Coding of encapsulated ISUP IAM parameters in outgoing INVITE	36
5.3.1.3.3	Media offered in SDP of outgoing INVITE.....	36
5.4	Signalling Interworking of a Call from SIP-I based circuit-switched core network towards the ISUP based network.....	36
5.4.1	General.....	36
5.4.2	Interworking of received ISUP messages to SIP messages.....	36
5.4.3	Interworking of received SIP messages to ISUP messages.....	36
5.4.3.1	Receipt of encapsulated ISUP information within SIP	36
5.4.3.2	Special Procedures for the Reception of SIP INVITE request	37
5.4.3.2.1	Propagation of overlap signalling toward the 3GPP CS domain	37
5.4.3.2.2	Derivation of TMR, USI and HLC parameters within sent IAM message.....	37
5.4.3.2.3	Receipt of SIP INVITE without SDP offer	37
5.4.3.2.4	Special Procedures for deferred MGW selection procedure.....	37
5.5	Supplementary services	37
5.5.1	Special procedures for supplementary service interworking	37
5.5.2	Interworking of CLIP/CLIR supplementary service.....	38
5.5.3	Interworking of Call Hold (HOLD) supplementary service	38
5.5.4	Interworking of Completion of Calls to Busy Subscriber (CCBS) supplementary service to SIP networks.....	38
5.6	User Plane Interworking.....	38
5.6.1	General.....	38
5.6.2	DTMF.....	38
5.7	Example Call flows	38
6	Interworking between a SIP-I based circuit-switched core network and a BICC based network	39
6.1	Reference Model.....	39
6.2	Control Plane Interworking	40
6.2.1	General.....	40
6.2.2	Signalling interactions between network entities in the control plane	40
6.3	Signalling Interworking of a Call from the BICC based network towards the SIP-I based circuit-switched core network.....	41
6.4	Signalling Interworking of a Call from SIP-I based circuit-switched core network towards the BICC based network.....	41
6.5	Supplementary services	41
6.6	Codec Negotiation between a BICC based network and a SIP-I based circuit-switched core network	42
6.6.1	General.....	42
6.6.2	Codec Negotiation from SIP-I on Nc to BICC Network.....	42
6.6.2.1	Sending of IAM.....	42
6.6.2.2	Sending of SDP Answer	42
6.6.2.3	Mid-call Codec Negotiation initiated from SIP-I on Nc	42
6.6.3	Codec Negotiation from BICC Network to SIP-I on Nc	42
6.6.3.1	Sending of initial SDP Offer.....	42
6.6.3.2	Responding to Serving Node initiating Codec Negotiation	42
6.6.3.3	Mid-call Codec Negotiation initiated from BICC	43
6.7	DTMF Signalling Interworking applicable for all Calls between a BICC network and a SIP-I based circuit-switched core network	43
6.7.1	General.....	43
6.7.2	DTMF transfer from SIP-I on Nc to BICC network (Out-of-Band DTMF).....	43
6.7.3	DTMF transfer from BICC network (Out-of-Band DTMF) to SIP-I on Nc.....	44

6.7.4	SIP-I on Nc interworking with BICC for Inband DTMF	45
6.8	User Plane Interworking	45
6.8.1	General	45
6.8.2	DTMF Interworking	45
6.9	Example Call flows	45
7	Interworking between a SIP-I based circuit-switched core network and the IP Multimedia (IM) Core Network (CN) Subsystem.....	46
7.1	Reference Model.....	46
7.1.1	General.....	46
7.1.2	Signalling interactions between network entities in the control plane	46
7.2	Signalling Interworking of a Call from the IP Multimedia Subsystem towards the SIP-I based circuit- switched core network	47
7.2.1	General	47
7.2.2	Exceptions from forwarding received SIP messages	48
7.2.3	Sending SIP INVITE request.....	48
7.2.4	Updating Precondition Information	49
7.2.5	SDP Codec Negotiation	49
7.2.6	MGW Selection	49
7.2.7	Autonomous Release.....	49
7.2.8	Further setting of SIP header values	49
7.3	Signalling Interworking of a Call from SIP-I based circuit-switched core network towards the IP Multimedia Subsystem.....	51
7.3.1	General.....	51
7.3.2	Exceptions from forwarding received SIP messages	51
7.3.3	Sending SIP INVITE request.....	52
7.3.4	Updating Precondition Information	52
7.3.5	Receipt of SIP redirect (3xx) response.....	53
7.3.6	SDP Codec Negotiation	53
7.3.7	MGW Selection	53
7.3.8	Autonomous Release.....	54
7.3.9	Handling of forked SIP Responses	54
7.3.9.1	SIP Dialogues.....	54
7.3.9.2	Reception of non-100 provisional Responses to initial INVITE	54
7.3.9.3	Reception of final Responses to initial INVITE.....	54
7.3.10	Further setting of SIP header values	55
7.4	DMTF Signalling Interworking applicable for all Calls between an IP Multimedia CN Subsystem and a SIP-I based circuit-switched core network.....	56
7.5	User Plane Interworking.....	56
7.5.1	General	56
7.5.2	DTMF Interworking	57
7.6	Example Call flows	57
7.6.1	General	57
7.6.2	Incoming Call flows	57
7.6.2.1	Successful Call Establishment and Call Release.....	57
7.6.2.2	Autonomous Release at MGCF.....	59
7.6.3	Outgoing Call flows	60
7.6.3.1	Outgoing Call, Sending of INVITE is deferred	60
7.6.3.2	Outgoing Call, Sending of INVITE is not deferred	61
7.6.3.3	Interworking with forked SIP INVITE Requests	63
7.7	CS Supplementary Services and IMS Supplementary Services	66
7.7.0	General	66
7.7.1	Number Identification Services	66
7.7.1.1	CS CN Supplementary Service - Calling Line Identification Presentation/Restriction (CLIP/CLIR).....	66
7.7.1.2	CS CN Supplementary Service - Connected Line Identification Presentation /Restriction (COLP/COLR)	66
7.7.1.3	IMS Supplementary Service - Originating Identification Presentation (OIP) and Originating Identification Restriction (OIR)	66
7.7.1.4	IMS Supplementary Service - Terminating Identification Presentation (TIP) and Terminating Identification Restriction (TIR).....	66
7.7.1.5	CS CN Supplementary Service – Direct Dialling In	66

7.7.1.6	CS CN Supplementary Service – Malicious Call Identification.....	67
7.7.1.7	IMS Supplementary Service – Malicious Communication Identification (MCID).....	67
7.7.1.8	CS CN Supplementary Service – Subaddressing.....	67
7.7.2	Diversion Services	67
7.7.2.1	CS CN Supplementary Service - Call Forwarding Services (CFU, CFB, CFNRy, CFNRc)	67
7.7.2.2	CS CN Supplementary Service – Call Deflection (CD)	67
7.7.2.3	IMS Supplementary Service – Communication Diversion (CDIV).....	67
7.7.3	Waiting Services	67
7.7.3.1	CS CN Supplementary Service – Call Waiting	67
7.7.3.2	IMS Supplementary Service – Communication Waiting (CW)	67
7.7.4	Hold Services	67
7.7.4.1	CS CN Supplementary Service – Call Hold.....	67
7.7.4.2	IMS Supplementary Service – Communication Hold (HOLD).....	68
7.7.5	Multiparty Services.....	68
7.7.5.1	CS CN Supplementary Services – Conference Calling (CONF) and Three-Party (3PTY)	68
7.7.5.2	IMS Supplementary Service – Conference (CONF)	68
7.7.6	Closed User Group Service	68
7.7.6.1	CS CN Supplementary Service – Closed User Group (CUG)	68
7.7.6.2	IMS Supplementary Service - Closed User Group (CUG).....	68
7.7.7	Charging Services	68
7.7.7.1	CS CN Supplementary Service – Advice of Charge (AoC).....	68
7.7.7.2	IMS Supplementary Service – Advice of Charge (AOC).....	68
7.7.7.3	CS CN Supplementary Service – International Telecommunication Charge Card (ITCC).....	68
7.7.7.4	CS CN Supplementary Service – Reverse Charging (REV).....	68
7.7.8	Barring Services	69
7.7.8.1	CS CN Supplementary Service - Barring of Outgoing Calls	69
7.7.8.2	CS CN Supplementary Service - Barring of Incoming Calls	69
7.7.8.3	CS CN Supplementary Service - Anonymous Call Rejection (ACR)	69
7.7.8.4	IMS Supplementary Service – Communication Barring (CB)	69
7.7.8.5	IMS Supplementary Service – Anonymous Communication Rejection (ACR)	69
7.7.9	Transfer Services.....	69
7.7.9.1	CS CN Supplementary Service – Explicit Call Transfer (ECT).....	69
7.7.9.2	IMS Supplementary Service – Explicit Communication Transfer (ECT)	69
7.7.10	Call Completion Services	70
7.7.10.1	CS CN Supplementary Service – Completion of Calls to Busy Subscriber (CCBS).....	70
7.7.10.2	CS CN Supplementary Service – Completion of Calls on No Reply (CCNR)	70
7.7.10.3	IMS Supplementary Service – Completion of Communications to Busy Subscriber (CCBS) and Completion of Communication on No Reply (CCNR)	70
7.7.11	Miscellaneous Services	70
7.7.11.1	CS CN Supplementary Service - Multi-Level Precedence and Pre-emption (MLPP).....	70
7.7.11.2	CS CN Supplementary Service - Multiple Subscriber Profile (MSP)	70
7.7.11.3	CS CN Supplementary Service - Multicall	70
7.7.11.4	CS CN Supplementary Service - Calling Name Presentation.....	70
7.7.11.5	CS CN Supplementary Service – User-to-User Signalling (UUS)	70
7.7.11.6	IMS Supplementary Service – Message Waiting Indication (MWI)	70
7.7.11.7	CS CN Supplementary Service - Global Virtual Network Service (GVNS).....	70
7.7.11.8	CS CN Supplementary Service - Terminal Portability (TP)	71
7.7.12	Customized Alerting Tones Services.....	71
7.7.12.1	CS CN Supplementary Service - Customized Alerting Tones (CAT).....	71
7.7.12.2	IMS Supplementary Service - Customized Alerting Tones (CAT) for early session model	71
7.7.12.3	IMS Supplementary Service - Customized Alerting Tones (CAT) for forking model.....	71
7.7.12.4	IMS Supplementary Service - Customized Alerting Tones (CAT) for gateway model.....	71
7.8	MGCF – IM-MGW Interaction.....	71
7.8.1	General	71
7.8.2	Call related Procedures for Terminations towards the IM CN Subsystem	71
7.8.3	Call related Procedures for Terminations towards SIP-I based Circuit-switched Core Network	71
7.8.4	Non-call related procedures.....	72

Annex A (normative):	Interconnecting functionalities in SIP-I based CS domain	72
A.1	General	72
A.2	Stage 2 Requirements	72
A.3	Border Control architecture	73
A.4	Void	74
A.5	Procedures at the CS-IBCF	74
A.5.1	General	74
A.5.2	CS-IBCF as an exit point	75
A.5.2.1	Initial requests	75
A.5.2.2	Subsequent requests	75
A.5.2.3	CS-IBCF-initiated call release	76
A.5.2.4	THIG functionality in the CS-IBCF	76
A.5.2.4.1	General	76
A.5.2.4.2	Encryption for network topology hiding	76
A.5.2.5	ALG functionality in the CS-IBCF	77
A.5.2.6	Screening of SIP-I signalling	77
A.5.2.6.1	General	77
A.5.2.6.2	CS-IBCF procedures for SIP headers	77
A.5.2.6.3	CS-IBCF procedures for SIP message bodies	78
A.5.2.7	Void	78
A.5.3	CS-IBCF as an entry point	78
A.5.3.1	Initial requests	78
A.5.3.2	Subsequent requests	78
A.5.3.3	CS-IBCF-initiated call release	79
A.5.3.4	THIG functionality in the CS-IBCF	79
A.5.3.4.1	General	79
A.5.3.4.2	Decryption for network topology hiding	80
A.5.3.5	ALG functionality in the CS-IBCF	80
A.5.3.6	Screening of SIP-I signalling	80
A.5.3.7	Void	81
A.6	Procedures at the CS-TrGW	81
A.6.1	Transport Plane Control procedures	81
A.7	CS-IBCF – CS-TrGW Interaction	81
A.7.1	General	81
A.7.1.1	Network Model	81
A.7.1.2	Signalling flows	81
A.7.1.2.1	Basic Procedures	81
A.7.1.2.1.1	Call Establishment	81
A.7.1.2.1.2	Call Release	83
A.7.1.2.2	Specific Use Cases	84
A.7.1.2.2.1	CS-IBCF as Entry Point, Call Establishment with IP Version Interworking	84
A.7.1.2.2.2	Hanging Termination Detection	84
A.7.1.2.2.3	Gate Management	85
A.7.1.2.2.4	QoS Packet Marking	85
A.7.1.2.2.5	IP Realms	86
A.7.1.2.2.6	Media Inactivity Detection	87
A.7.1.2.2.7	RTCP Handling	87
A.7.1.2.2.8	Bandwidth Policing	88
A.7.1.2.2.8.1	Overview	88
A.7.1.2.2.8.2	Bandwidth policing procedures	88
A.7.1.2.2.9	Through-Connection	89
A.7.1.2.2.10	Emergency Call	89
A.7.2	Ix Signalling Procedures	90
A.7.2.1	Introduction	90
A.7.2.2	Call Related Procedures	90
A.7.2.2.1	Reserve TrGW Connection Point	90
A.7.2.2.2	Configure TrGW Connection Point	93

A.7.2.2.3	Reserve and Configure TrGW Connection Point	95
A.7.2.2.4	Release TrGW Termination	98
A.7.2.2.5	IP Bearer Released.....	98
A.7.2.2.6	Media Inactivity Detection.....	99
A.7.2.2.7	Termination heartbeat indication	99
A.7.2.2.8	Change Through-Connection.....	100
A.7.2.3	Non-Call Related Procedures	100
A.7.2.3.1	Introduction.....	100
A.7.2.3.2	Realm Availability Change - Activate	101
A.7.2.3.3	Realm Availability Change - Indication	102
A.8	(G)MSC – CS-MGW Interaction.....	102
A.8.1	General	102
A.8.1.1	Network Model.....	102
A.8.1.2	Signalling flows.....	102
Annex B (normative):	Additional Interworking Procedures between a SIP-I based circuit-switched Core Network and the IP Multimedia (IM) Core Network (CN) Subsystem to Support Special Services.....	103
B.1	General.....	103
B.2	Global Text Telephony.....	103
Annex C (informative):	Change history.....	103

Foreword

This Technical Specification has been produced by the 3rd Generation Partnership Project (3GPP).

The contents of the present document are subject to continuing work within the TSG and may change following formal TSG approval. Should the TSG modify the contents of the present document, it will be re-released by the TSG with an identifying change of release date and an increase in version number as follows:

Version x.y.z

where:

- x the first digit:
 - 1 presented to TSG for information;
 - 2 presented to TSG for approval;
 - 3 or greater indicates TSG approved document under change control.
- y the second digit is incremented for all changes of substance, i.e. technical enhancements, corrections, updates, etc.
- z the third digit is incremented when editorial only changes have been incorporated in the document.

1 Scope

The present document specifies the interworking between SIP-I based circuit-switched core network, as specified in 3GPP TS 23.231 [3] and 3GPP TS 29.231 [4], with out-of-band transcoder control related procedures in 3GPP TS 23.153 [5], and:

- an external SIP-I based signalling network compliant to ITU-T Recommendation Q.1912.5 [6],
- an ISUP (ITU-T Recommendations Q.761 to Q.764 [7]) based network such as an ISUP based 3GPP CS Domain or a PSTN,
- a BICC (ITU-T Recommendations Q.1902.1 to Q.1902.6 [8]) based network such as an BICC based 3GPP CS Domain as specified in 3GPP TS 23.205 [9] and 3GPP TS 29.205 [10],
- an IP Multimedia Subsystem, as specified in 3GPP TS 23.228 [11] and 3GPP TS 24.229 [12].

2 References

The following documents contain provisions which, through reference in this text, constitute provisions of the present document.

- References are either specific (identified by date of publication, edition number, version number, etc.) or non-specific.
- For a specific reference, subsequent revisions do not apply.
- For a non-specific reference, the latest version applies. In the case of a reference to a 3GPP document (including a GSM document), a non-specific reference implicitly refers to the latest version of that document *in the same Release as the present document*.

- [1] 3GPP TR 21.905: "Vocabulary for 3GPP Specifications".
- [2] 3GPP TS 23.002: "Network architecture".
- [3] 3GPP TS 23.231: "SIP-I based circuit-switched core network; Stage 2".
- [4] 3GPP TS 29.231: "Application of SIP-I Protocols to Circuit Switched (CS) core network architecture; Stage 3".
- [5] 3GPP TS 23.153: "Out of Band Transcoder Control; Stage 2".
- [6] ITU-T Recommendation Q.1912.5 (03/04): "Interworking between Session Initiation Protocol (SIP) and Bearer Independent Call Control Protocol or ISDN User Part".
- [7] ITU-T Recommendations Q.761 to Q.764 (12/99): "Specifications of Signalling System No.7 ISDN User Part (ISUP)".
- [8] ITU-T Recommendations Q.1902.1 to Q.1902.6 (07/01): "Bearer Independent Call Control".
- [9] 3GPP TS 23.205: "Bearer-independent circuit-switched core network; Stage 2".
- [10] 3GPP TS 29.205: "Application of Q.1900 series to Bearer Independent CS Network architecture; Stage 3".
- [11] 3GPP TS 23.228: "IP Multimedia subsystem (IMS)".
- [12] 3GPP TS 24.229: "IP Multimedia Call Control Protocol based on SIP and SDP".
- [13] 3GPP TS 29.163: "Interworking between the IP Multimedia (IM) Core Network (CN) subsystem and Circuit Switched (CS) networks".
- [14] IETF RFC 791: "Internet Protocol".

- [15] IETF RFC 768: "User Datagram Protocol".
- [16] IETF RFC 793: "Transmission Control Protocol".
- [17] IETF RFC 2460: "Internet Protocol, Version 6 (IPv6) Specification".
- [18] IETF RFC 4960: "Stream Control Transmission Protocol".
- [19] IETF RFC 3204: "MIME media types for ISUP and QSIG Objects".
- [20] IETF RFC 3261: "SIP: Session Initiation Protocol".
- [21] IETF RFC 3262: "Reliability of Provisional Responses in the Session Initiation Protocol (SIP)".
- [22] IETF RFC 3264: "An Offer/Answer Model with the Session Description Protocol (SDP)".
- [23] IETF RFC 3312: "Integration of Resource Management and Session Initiation Protocol (SIP)".
- [24] 3GPP TS 23.014: "Support of Dual Tone Multi-Frequency (DTMF) signalling".
- [25] 3GPP TS 24.629: "Explicit Communication Transfer (ECT) using IP Multimedia (IM) Core Network (CN) subsystem".
- [26] 3GPP TS 24.610: "Communication HOLD (HOLD) using IP Multimedia (IM) Core Network (CN) subsystem".
- [27] ITU-T Recommendation Q.765 (2000): "Signalling System No. 7 – Application transport mechanism".
- [28] ITU-T Recommendation Q.765.5 (2000): "Signalling system No. 7 – Application transport mechanism: Bearer Independent Call Control (BICC)".
- [29] 3GPP TS 29.238: "Interconnection Border Control Functions – Transition Gateway; H.248 Profile; Stage 3".
- [30] IETF RFC 3263: "Session Initiation Protocol (SIP): Locating SIP Servers".
- [31] IETF RFC 4028: "Session Timers in the Session Initiation Protocol (SIP)".
- [32] IETF RFC 3325: "Private Extensions to the Session Initiation Protocol (SIP) for Asserted Identity within Trusted Networks".
- [33] ITU-T Recommendation H.248.1 (2002): "Gateway control protocol: Version 3".
- [34] Void.
- [35] Void.
- [36] IETF RFC 5079: "Rejecting Anonymous Requests in the Session Initiation Protocol (SIP)".
- [37] 3GPP TS 29.162: "Interworking between the IM CN subsystem and IP networks".
- [38] IETF RFC 3550: "RTP: A Transport Protocol for Real-Time Applications".
- [39] IETF RFC 3556: "Session Description Protocol (SDP) Bandwidth Modifiers for RTP Control Protocol (RTCP) Bandwidth".
- [40] IETF RFC 3605: "Real Time Control Protocol (RTCP) attribute in Session Description Protocol (SDP)".
- [41] IETF RFC 2474: "Definition of the Differentiated Services Field (DS Field) in the IPv4 and IPv6 Headers".
- [42] IETF RFC 2216 (1997): "Network Element Service Template".
- [43] 3GPP TS 29.414: "Core network Nb data transport and transport signalling".

- [44] 3GPP TS 32.407: "Telecommunication Management; Performance Management (PM) Performance measurements Core Network (CN) Circuit Switched (CS) domain".
- [45] 3GPP TS 23.226: "Global Text Telephony (GTT); stage 2".
- [46] ITU-T Recommendation T.140 (02/98): "Text conversation presentation protocol".
- [47] IETF RFC 4103: "RTP Payload for Text Conversation".
- [48] ITU-T Recommendation V.18 (11/00): "Operational procedures for modems in the text telephone mode".
- [49] 3GPP TS 26.226: "Cellular text telephone modem; General description".
- [50] 3GPP TS 26.235: "Packet switched conversational multimedia applications; Default codecs".
- [51] 3GPP TS 26.236: "Packet switched conversational multimedia applications; Transport protocols".
- [52] 3GPP TS 26.114: "IP Multimedia Subsystem (IMS); Multimedia Telephony; Media handling and interaction".
- [53] ITU-T Recommendation H.248.1 (05/2002): "Gateway control protocol: Version 2" including the Corrigendum1 for Version 2 (03/04).
- [54] 3GPP TS 29.332: "Media Gateway Control Function (MGCF) – IM-Media Gateway (IM-MGW) interface, Stage 3".
- [55] 3GPP TS 29.232: "Media Gateway Controller (MGC) - Media Gateway (MGW) interface; Stage 3".

3 Definitions, symbols and abbreviations

3.1 Definitions

For the purposes of the present document, the terms and definitions given in 3GPP TR 21.905 [1] and the following apply:

Interworking Unit (IWU): Logical entity that interworks SIP-I signalling in the 3GPP CS Domain with any of the following signalling: (a) SIP-I signalling of an external SIP-I network, (b) ISUP signalling of a PSTN, and (c) BICC or ISUP signalling of a 3GPP CS Domain.

User Plane Interworking Unit (UP-IWU): Logical entity that performs user plane interworking between the SIP-I based CS Domain and an external SIP-I network, or external ISUP network, or BICC/ISUP based 3GPP CS network.

3.2 Abbreviations

For the purposes of the present document, the abbreviations given in 3GPP TR 21.905 [1] and the following apply: An abbreviation defined in the present document takes precedence over the definition of the same abbreviation, if any, in 3GPP TR 21.905 [1].

ALG	Application Level Gateway
ANM	ANswer Message
APM	Application Transport Mechanism
B2BUA	(SIP) Back-to-Back User Agent
BGCF	Breakout Gateway Control Function
BICC	Bearer Independent Call Control
CON	Connect message
COT	Continuity message
CPG	Call ProGress message
CS-IBCF	CS (do main) IBCF
CS-TrGW	CS (do main) TrGW

IBCF	Interconnection Border Control Function
ITU-T	International Telecommunication Union – Telecommunication Standardization Sector
IM-MGW	IP Multimedia Media Gateway Function
IW-MSC	Interworking MSC
MIME	Multi-purpose Internet Mail Extensions
MRFP	Multimedia Resource Function Processor
NA(P)T	Network Address Translation / Network Address and Port Translation
NNI	Network to Network Interface
O-MSC	Originating MSC
OoB	Out of Band
OoBTC	Out of Band Transcoder Control
RES	RESume
RLC	Release Complete
SCTP	Stream Control Transmission Protocol
SIP-I	SIP with encapsulated ISUP
SUS	SUSpend
TDM	Time-Division Multiplexing
THIG	Topology Hiding Internetwork Gateway
TMR	Transmission Medium Requirement
TrGW	Transition Gateway
UA	(SIP) User Agent
UP-IWU	User Plane Interworking Unit
USI	User Service Information

4 Interworking between a SIP-I based circuit-switched core network and an external SIP-I based network

4.1 Reference Model

Figure 4.1.1 shows the interworking reference model for the interworking between a SIP-I based circuit-switched core network and an external SIP-I based network:

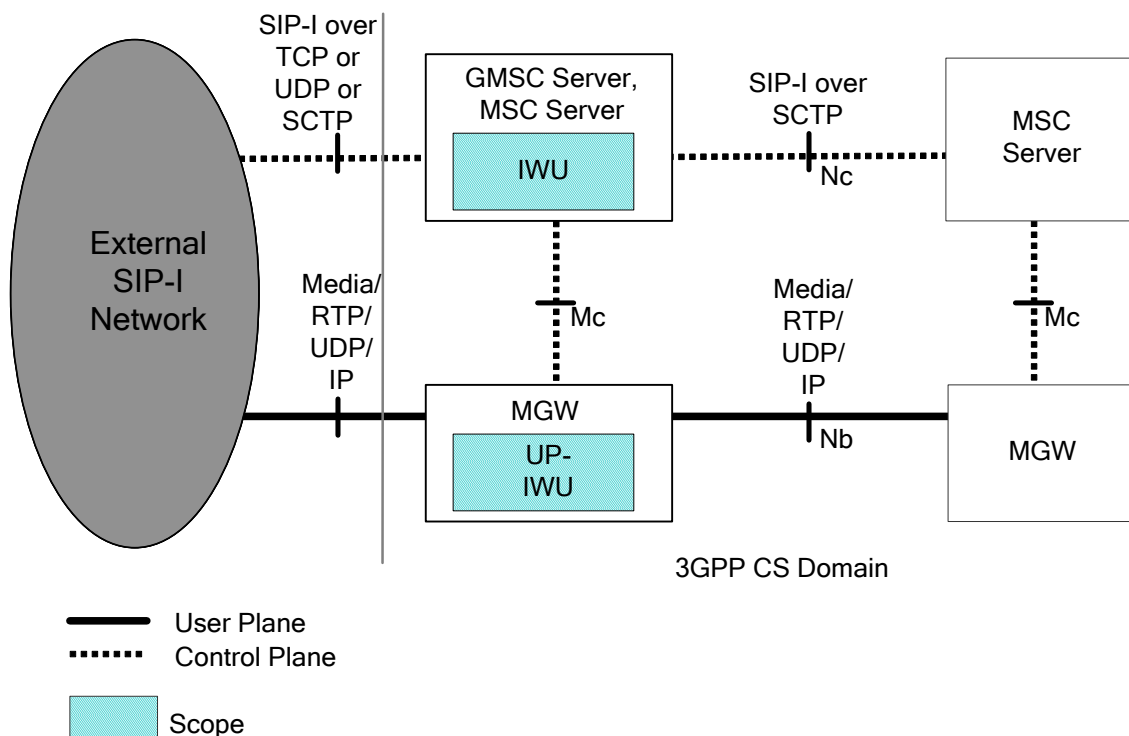

Figure 4.1.1: interworking reference model

The IWU provides the control plane interworking between the external network and the SIP-I based circuit-switched core network. The IWU is a logical function within the GMSC Server (for incoming calls) and the MSC Server (for outgoing calls) that may reside with other 3GPP logical functions.

The user plane interworking is provided by the UP-IWU. The UP-IWU is a logical function within the MGW.

NOTE: In call scenarios without the need for the (G)MSC server to manipulate the bearer, the (G)MSC server may perform call control signalling without any associated MGW by not inserting a MGW in the bearer path during the call establishment. Call scenarios where the (G)MSC server needs to manipulate the bearer, e.g. scenarios with insertion of tones or announcements, lawful interception, CAMEL services do not allow this optimisation.

Nb reference point: The Nb reference point is defined in accordance with 3GPP TS 29.414 [43].

Nc reference point: The Nc reference point is defined in accordance with 3GPP TS 29.231 [4].

4.2 Signalling Interworking of a Call from the external SIP-I based network towards the SIP-I based circuit-switched core network

4.2.1 Interworking of SIP-I messages received from external SIP-I network

4.2.1.1 General

The IWU shall decapsulate the ISUP message from the received SIP message according to the rules for Profile C in ITU-T Recommendation Q.1912.5 [6].

The resulting ISUP message shall be encapsulated into the SIP message. The selected SIP Header fields relating to the handling of the ISUP body shall be set as specified in subclause 5.4.1.2 of ITU-T Recommendation Q.1912.5 [6]. The IWU sends the constructed SIP message to the succeeding 3GPP node.

4.2.1.2 Call Release from external SIP-I network when encapsulated REL is missing

If the IWU receives a SIP BYE request without an encapsulated ISUP message then the IWU may construct an ISUP REL message according to the rules specified in ITU-T Recommendation Q.1912.5 [6] and encapsulate it into a SIP message, which is sent to the succeeding 3GPP node.

NOTE: A SIP BYE request without an encapsulated ISUP message can be received from a CS-IBCF or from a node of an interconnect network when they initiate autonomous call release. It is expected that a generated ISUP REL won't add any additional information which is not available in the received SIP BYE request.

The IWU shall send a 200 OK final response to the BYE request without an encapsulated RLC message towards the external SIP-I network.

4.2.2 Special Procedures for the reception of initial SIP INVITE requests

4.2.2.1 Receipt of SIP INVITE request

If the initial SIP-I INVITE request does not provide a complete number, then the IWU shall collect all digits required to identify the called subscriber in subsequent SIP INVITE requests as specified for Profile C in ITU-T Recommendation Q.1912.5 [6]. The IWU shall not propagate overlap signalling as described for Profile C in ITU-T Recommendation Q.1912.5 [6].

The IWU shall trigger GMSC functions after having constructed the ISUP message, as described in 4.2.1 above. The GMSC interrogates the HLR to get a roaming number (MSRN). The Called Party Number in the ISUP IAM message is changed by the GMSC function to the MSRN. The IWU shall include the MSRN into the Request-URI as the new target.

4.2.2.2 Receipt of SIP INVITE requests with SDP

Based on configuration the IWU may choose to transcode media. But the IWU shall always provide the TMR/USI/HLC parameters as received on the incoming side.

4.2.2.3 Receipt of SIP INVITE request without SDP

An IWU may reject receipt of SIP INVITE requests without SDP offer. Otherwise the rules of subclause 4.2.2.1 apply with the following deviations:

The IWU shall construct an SDP offer with contents according to local policy, e.g. SDP for a G.711 speech call. The IWU may use the TMR and USI parameters of the encapsulated IAM to determine the desired service and construct the SDP offer accordingly. The IWU may then send to the succeeding 3GPP node the SIP INVITE request with the constructed SDP offer and encapsulated IAM.

If reliable provisional responses (see IETF RFC 3262 [21]) are supported in the external SIP-I network, the IWU may immediately send the SDP offer within a 183 Session Progress message to the preceding node. When the IWU receives the SDP answer then the IWU should send to the succeeding 3GPP node the SIP INVITE request with an encapsulated IAM message. Otherwise, the IWU shall behave in accordance with the paragraph above.

4.2.2.4 MGW Selection

The IWU may apply the optional "optimised MGW selection", "deferred MGW selection" or "MGW bypass" procedures towards the succeeding SIP-I based circuit switched core network as described in subclause 4.4 of TS 3GPP 23.231 [3].

If MGW bypass is implemented and the IWU receives a MGW identifier:

- in a SDP offer from external SIP-I network the IWU shall remove the MGW identifier from the SDP offer before propagating the SDP offer to the succeeding 3GPP node;
- in a SDP answer from the succeeding 3GPP node the IWU shall remove the MGW identifier from the SDP answer before propagating back the SDP answer to the external network.

NOTE: If MGW bypass is implemented and the external network does not include a specified connection address (0.0.0.0 for IPv4) then this will be interpreted as supporting deferred MGW selection by the succeeding node. The succeeding node will select a MGW accordingly and may return the MGW Identifier to the IWU).

Otherwise the IWU shall seize a MGW and shall include the MGW connection address into the SDP offer of the initial SIP INVITE request it will send to the succeeding 3GPP node.

4.2.3 Interworking of SIP-I messages received from succeeding 3GPP node

Whenever the IWU receives from the succeeding 3GPP node a SIP message with an encapsulated CON, ACM, CPG, ANM, SUS, RES message then the IWU sends the SIP message in accordance with rules in accordance with ITU-T Recommendation Q.1912.5 [6] to the external SIP-I network and the encapsulated ISUP message shall not be modified.

4.2.4 Special Procedures for Profile Interworking

4.2.4.1 Support of 100Rel

The IWU receiving a SIP INVITE with or without tag "100Rel" in the SUPPORTED or the REQUIRED header from the external SIP-I network shall advertise its preference of provisional reliable responses to the succeeding 3GPP node via a SUPPORTED header in the initial SIP INVITE request.

As an option the IWU may consider a received SIP INVITE request without "100Rel" as erroneous and reject the INVITE request with a 421 "Extension Required" response.

NOTE: The option to forward a SIP INVITE request to the succeeding 3GPP node with or without tag "100Rel", if the external network does not support reliable provisional responses, is not specified in the present specification.

4.2.4.2 Support for UPDATE method

The IWU receiving a SIP INVITE with or without the UPDATE method included in the ALLOW header shall advertise its support for the UPDATE method to the succeeding 3GPP node by listing the UPDATE method in the ALLOW header field.

As an option the IWU may consider a received initial SIP INVITE request without listing UPDATE in the ALLOW header field as erroneous and reject the INVITE request with a 403 "Forbidden" response.

NOTE: The option to forward a SIP INVITE request to the succeeding 3GPP node without indicating support of the UPDATE method, if the external network does not support the UPDATE method, is not specified in the present specification.

4.2.4.3 Support for Preconditions

When the incoming SIP INVITE request indicates that remote preconditions are met and local preconditions are met then the IWU may either not include the tag "precondition" and exclude appropriate SDP lines, or include the tag "preconditions" in the SUPPORTED header and provide an SDP offer indicating that preconditions are met.

When the incoming SIP INVITE request does not contain a "precondition" tag the IWU shall assume the preconditions have been met within the external SIP-I network. If local preconditions are met then the IWU may either not include the tag "precondition" and exclude appropriate SDP lines, or include the tag "precondition" in the SUPPORTED header and provide an SDP offer indicating that preconditions are met.

When the incoming SIP INVITE request indicates that remote preconditions are not met or when local preconditions are not met then the IWU shall include the tag "precondition" in the REQUIRE header or SUPPORTED header in the SIP INVITE request and shall encode preconditions in the SDP offer that the related local preconditions for QoS are not met, using the segmented status type, as defined in IETF RFC 3312 [23], as well as the strength-tag value "mandatory" for the local segment and the strength-tag value "optional" for the remote segment when sending the message to the succeeding 3GPP node. Or the IWU may defer forwarding the SIP INVITE request until remote local preconditions are met.

When the incoming SIP INVITE request indicates that preconditions have not been met and the IWU will not include a MGW the SDP with preconditions information shall be transited unchanged and the "precondition" tag shall be transited in the same header as received.

NOTE 1: The use of the SUPPORTED header is a deviation from IETF RFC 3312 [23] when the strength-tag contains a "mandatory" value.

NOTE 2: The support of preconditions is mandated at the Nc interface. Therefore a response without "precondition" can be considered as erroneous if preconditions were not met.

NOTE 3: The setting of the "Continuity Check Indicator" in the "Nature of Connection Indicators" parameter within the encapsulated IAM by the IWU is of no significance. The value is ignored by the succeeding 3GPP node.

4.2.5 Support for Codec Negotiation

If the IWU uses the MGW bypass option as defined in 3GPP TS 23.231 [3], then the IWU is not involved in the codec negotiation procedure and transits SDP offers and answers unchanged. Otherwise, the remaining text of this subclause applies:

If the IWU receives from the external SIP-I based network a SIP request with an SDP offer containing a codec list with or without the 3GPP_OoBTC_Indicator, the IWU shall follow the procedures defined for a 3GPP Intermediate Node in clause 9 of 3GPP TS 23.153 [5].

If the IWU receives from the external SIP-I based network an INVITE or re-INVITE request without any codec information, the IWU shall send an SDP offer to the succeeding 3GPP SIP-I node, where it either shall follow the procedures defined for a 3GPP node originating SDP offer in clause 9 of 3GPP TS 23.153 [5], or shall create an SDP

offer with the default PCM codec. The IWU shall send the selected codec within an SDP offer towards the preceding external node.

NOTE: Which codecs are negotiable with the external SIP-I network may depend on operator choices and preferences (local policy).

4.2.6 Special Procedures for the reception of SIP Re-INVITE requests

4.2.6.1 Receipt of SIP Re-INVITE request without SDP

Upon receipt of a SIP Re-INVITE request without SDP, the IWU shall

- construct an SDP offer with contents reflecting the SDP already negotiated with the external SIP-I network for the call, including codec information as specified in subclause 4.2.5, and send the SDP offer within a 200 OK (INVITE) message to the external SIP-I network; or
- reject the SIP Re-INVITE request.

4.3 Signalling Interworking of a Call from SIP-I based circuit-switched core network towards the external SIP-I based network

4.3.1 Interworking of SIP-I messages received from preceding 3GPP node

4.3.1.1 General

An IWU receiving SIP messages with encapsulated ISUP information shall apply any interworking procedures detailed for Profile C in ITU-T Recommendation Q.1912.5 [6] affecting parameters within the ISUP, and then proceed to encapsulate any ISUP information received (with the exception of the excluded messages detailed in 5.4.3 of ITU-T Recommendation Q.1912.5 [6]) in a SIP message in a MIME body according to IETF RFC 3204 [19]. The selected SIP Header fields relating to the handling of the ISUP body shall be set as specified in ITU-T Recommendation Q.1912.5 [6].

4.3.1.2 Call Release from external SIP-I network when encapsulated REL is missing

If the IWU receives a SIP BYE request or 4XX, 5XX, 6XX final response to the initial INVITE request without an encapsulated ISUP REL message then the IWU may construct the ISUP REL message according to the rules specified in ITU-T Recommendation Q.1912.5 [6] and encapsulate it into the SIP message, which is sent to the preceding 3GPP node.

NOTE: A SIP BYE request without an encapsulated ISUP message can be received from a CS-IBCF or from a node of an interconnect network when they initiate autonomous call release. It is expected that a generated ISUP REL message won't add any additional information which is not available in the received SIP BYE request.

The IWU shall send a 200 OK final response to the BYE request without an encapsulated ISUP RLC message towards the external SIP-I network.

4.3.2 Special Procedures for the reception of SIP INVITE requests

The IWU shall decapsulate the ISUP message. The IWU forwards the ISUP information to the "IW-MSC" functions, which may result in a modified ISUP message.

Based on configuration the IWU may choose to transcode media. If the IWU transcodes, it should set the TMR/USI/HLC parameters according to the codec applied in the SIP-I network. Otherwise, it should provide the TMR/USI/HLC parameters as received in the encapsulated IAM.

The IWU shall proceed to encapsulate the ISUP message into the SIP-INVITE request. The request URI shall be aligned with the called party number.

4.3.3 Special Procedures for Profile Interworking

4.3.3.1 Support of 100Rel

An IWU shall consider an initial SIP INVITE request received from the preceding 3GPP node without the tag "100Rel" in the SUPPORTED header or REQUIRED header as erroneous and shall reject the call accordingly.

An IWU sending a SIP INVITE request towards the external SIP-I network shall advertise its preference of provisional reliable responses via a SUPPORTED header containing the tag "100Rel".

If an IWU receives a provisional 101-199 response from the external SIP-I network with a REQUIRE header present with tag "100rel" then it shall include the tag "100Rel" into the REQUIRE header when the IWU propagates the response to the preceding 3GPP node.

If an IWU receives from the external SIP-I network a provisional 101-199 response without tag "100rel" in the REQUIRE header then the IWU shall

- either includes the tag "100Rel" into the REQUIRE header when it forwards the response to the preceding 3GPP node,
- or consider the response as erroneous and reject the call accordingly.

NOTE: The option to forward the response to the preceding 3GPP node without tag "100Rel", if the external network does not support reliable provisional responses, is not specified in the present specification.

4.3.3.2 Support for UPDATE method

An IWU sending a SIP INVITE towards the external SIP-I network shall advertise its support of the UPDATE method via the ALLOW header listing the UPDATE method.

The IWU receiving a response to a SIP INVITE request is allowed to generate the UPDATE method towards the external network if an ALLOW header is present listing the UPDATE method. Otherwise, the IWU is not allowed to generate UPDATE requests towards the external SIP-I network and one of the following options applies:

- The IWU shall return the response to the preceding 3GPP node containing an ALLOW header listing the UPDATE method.
- The IWU shall consider the response received from the external network as erroneous and reject the call accordingly.

NOTE: The option to forward the response to the preceding 3GPP node without UPDATE in the ALLOW header field, if the external network does not support the UPDATE method, is not specified in the present specification.

4.3.3.3 Support for Preconditions

When the incoming SIP INVITE request indicates that preconditions have not been met or when local preconditions are not met, the IWU shall use one of the following options:

- a) The IWU shall send a SIP INVITE request to a succeeding external SIP-I network and include the tag "precondition" in the SUPPORTED header. The IWU shall encode preconditions in the SDP offer indicating that the related local preconditions for QoS are not met, using the segmented status type, as defined in IETF RFC 3312 [23], as well as the strength-tag value "mandatory" for the local segment and the strength-tag value "optional" for the remote segment. The "precondition" tag shall be included in the SUPPORTED header. The IWU shall encapsulate the IAM message into the SIP INVITE request and should insert "continuity check not required" as the value of the Continuity check indicator within the Nature of Connection Indicators parameter in order to avoid that an external node, which does not support preconditions, is waiting for a COT message when the IWU is not able to send the COT message.

NOTE 1: Such an external node is not compliant to ITU-T Recommendation Q.1912.5 [6].

NOTE 2: The use of the SUPPORTED header is a deviation from IETF RFC 3312 [23] when a "mandatory" strength-tag is used.

The subsequent action depends on whether the response indicates support of preconditions:

- i) If the IWU receives from the external SIP-I network a provisional 101-199 response with a REQUIRE header or SUPPORTED header containing tag "precondition", then the IWU shall progress the call and when preconditions are met it shall send an UPDATE message or PRA CK message indicating that preconditions have been fulfilled. Preconditions are fulfilled when local preconditions are met and, if the incoming SIP INVITE request indicated that preconditions had not been met, the IWU has received an indication from the preceding 3GPP node that the preconditions are subsequently met.
- ii) If the IWU receives from the external SIP-I network a provisional 101-199 response without a REQUIRE header or SUPPORTED header containing tag "precondition" and if a provisional response or successful final response carrying an encapsulated ISUP message is received from external SIP-I network prior to preconditions being met, then these responses shall be queued and later be propagated to the preceding 3GPP node once preconditions are met. If responses carrying encapsulated ISUP are to be queued and the response carrying an encapsulated ISUP message is the first response carrying an SDP answer then the IWU shall generate a 183 Progress with the SDP answer and send it to the preceding node. The IWU shall not encapsulate an ISUP message into the 183 Progress.

NOTE 3: The option to allow the SIP response to be immediately forwarded is not specified in the present will result in the O-MSC receiving encapsulated ISUP prior to preconditions being met. In addition, reception of response without indication of support for preconditions at the O-MSC is not specified in the present specification.

If the IWU receives a failure response from the external network, then this shall immediately be forwarded to the preceding 3GPP node.

- b) Before sending the INVITE request to the external network the IWU shall wait until local preconditions are met and, if the incoming SIP INVITE request indicated that preconditions have not been met, it has received an indication from the preceding 3GPP node that the preconditions are met.

The initial INVITE request to the external SIP-I network may include a precondition tag in SUPPORTED header and indicate that preconditions have been met.

- c) The IWU shall send a SIP INVITE request to a succeeding external SIP-I network and include the tag "precondition" in the REQUIRE header. The IWU shall encode preconditions in the SDP offer indicating that the related local preconditions for QoS are not met, using the segmented status type, as defined in IETF RFC 3312 [23], as well as the strength-tag value "mandatory" for the local segment and the strength-tag value "optional" for the remote segment. The IWU shall encapsulate the IAM message into the SIP INVITE request and should insert "continuity check not required" as the value of the Continuity check indicator within the Nature of Connection Indicators parameter in order to avoid that an external node, which does not support preconditions, is waiting for a COT message when the IWU is not able to send the COT message.

NOTE 4: Such an external node is not compliant to ITU-T Recommendation Q.1912.5 [6].

The subsequent action depends on whether the response indicates support of preconditions:

- i) If the IWU receives from the external SIP-I network a provisional 101-199 response with a REQUIRE header or SUPPORTED header containing tag "precondition", then the IWU shall continue the call per response handling procedures described in option a) above.
- ii) If the IWU receives a 420 Bad Extension final response, then the IWU shall continue per option b) above by waiting for preconditions to be met before repeating the initial INVITE request.

When the incoming SIP INVITE request indicates that precondition are met and local preconditions are met, the IWU shall set up the session and may include a precondition tag in the SUPPORTED header and indicate that preconditions have been met.

When the incoming SIP INVITE request indicates that preconditions have not been met and the IWU will not include a MGW the SDP with preconditions information shall be transited unchanged and the "precondition" tag shall be transited in the same header as received.

4.3.4 Support for Codec Negotiation

When the IWU receives an INVITE with an SDP offer containing a structured codec list, the IWU shall follow the procedures defined for a 3GPP Intermediate Node in clause 9 of 3GPP TS 23.153 [5], unless the IWU uses the MGW bypass option.

NOTE: Which codecs are negotiable with the external SIP-I network may depend on operator choices and preferences (local policy).

4.3.5 MGW Selection

The IWU shall not perform "optimised MGW selection", or "deferred MGW selection" towards an external SIP-I network. The IWU shall select a MGW and include the MGW connection address in the SDP offer of the initial SIP INVITE request it sends to the external SIP-I network. The "MGW bypass" option may be deployed but in the case that the preceding 3GPP node signals the MGW identifier this identifier shall not be signalled to the external SIP-I network.

4.4 DTMF Signalling Interworking applicable for all Calls between an external SIP-I based network and a SIP-I based circuit-switched core network

4.4.1 General

DTMF signalling via the RTP Telephony Event (RTP Telephony Event) is mandated to be supported over the Nb interface for SIP-I based Circuit Switched Core Network on Nc Interface, see 3GPP TS 23.231 [3].

NOTE 1: According to 3GPP TS 23.231 [3] it is an option to choose either the RTP Telephony Event or inband DTMF transport within the PCM codec when only the default PCM codec is selected, however once RTP Telephony Event is chosen (indicated in the SDP answer) it must be used for any selected codec.

If MGW bypass is supported within the CS CN (see 3GPP TS 23.231, subclause 4.4.5 [3]), a terminating MSC or a 3GPP SIP-I intermediate node controlling a MGW that interfaces directly to the external network shall behave as an IWU, as its MGW is providing an UP-IW U function and therefore the SIP-I Server shall also comply with the procedures in this subclause. A GMSC Server or SIP-I intermediate node which is applying the MGW Bypass option shall then relay the SDP media lines for codecs and RTP Telephony Event in the SDP offers and answers transparently between the external SIP-I network and the 3GPP CS CN and is therefore not constrained by the procedures described in this subclause.

If the SDP answer sent towards the external SIP-I network or received from the external SIP-I network includes the RTP Telephony event, then the IWU shall request its MGW to transmit and receive the DTMF to/from the external SIP-I node within the RTP Telephony Event.

If the SDP answer sent towards or received from the SIP-I based CS CN includes the RTP Telephony event, then the IWU shall request its MGW to transmit and receive the DTMF to/from the SIP-I based CS CN within the RTP Telephony Event.

DTMF interworking is specified for interworking towards an external SIP-I network with the assumption that the following applies:

- External SIP-I network includes RTP Telephony event within SDP offers or SDP answers together with non-PCM speech codecs;
- External SIP-I network includes default PCM codec in SDP offers or SDP answers.

Therefore only the case where the external SIP-I network includes default PCM codec when not including the RTP Telephony event is described.

4.4.2 DTMF support in SDP offer sent to External SIP-I network

If an IWU receives an *initial* SDP offer from a preceding 3GPP SIP-I node with the RTP Telephony Event it shall forward the RTP Telephony Event in the offer to the succeeding (external) node. If the IWU then receives a SDP

answer from the succeeding node (external network) including the RTP Telephony Event, the IWU shall include the RTP Telephony Event in the SDP answer it forwards to the SIP-I based CS CN independently of the selected codec type, i.e. any DTMF payload received would then be simply relayed through the interworking MGW, and the IWU shall also include the RTP-telephony event in possible subsequent SDP offers it sends towards the succeeding external network node.

If an IWU receives an SDP offer from a preceding 3GPP SIP-I node without the RTP Telephony Event (only permitted if only default PCM codec offered) then it may:

- Include additional non-PCM speech codecs and shall then include the RTP Telephony Event in the subsequent offer to the succeeding external SIP-I node;

NOTE: If the answer from the external SIP-I node does not include the RTP Telephony Event then no interworking of DTMF Telephony Events or tones is required by the MGW.

or:

- send the SDP Offer to the external SIP-I node without the RTP Telephony Event (no compressed codecs included in the offer) and then no inband DTMF detection/insertion is required; or
- Send the SDP Offer to the external SIP-I node without any additional non-PCM speech codecs and include the RTP Telephony Event.

If the answer from the external SIP-I node includes the RTP Telephony event and the RTP Telephony event has not been offered by the preceding 3GPP SIP-I network then the IWU shall request its MGW (UP-IWU) to detect/insert inband DTMF tones to/from its preceding 3GPP SIP-I node and send/receive the DTMF to the external SIP-I node within the RTP Telephony Event, see subclause 14.4.8 in 3GPP TS 23.231 [3],

If an IWU receives a SDP offer from a preceding 3GPP SIP-I node with the RTP Telephony Event and then receives a SDP answer from the external SIP-I network which includes only the PCM speech codec and excludes the RTP Telephony Event the IWU may:

- apply "transcoding at the PLMN border" by selecting another speech codec than the default PCM codec for the interface toward the SIP-I based CS CN (if included in the offer) and then the IWU shall include the RTP Telephony Event in the answer it forwards to the SIP-I based CS CN, or:
- select default PCM codec towards the SIP-I CS CN and may include the RTP Telephony Event in the reply to the preceding (3GPP SIP-I) node and shall then request its MGW to relay inband DTMF to the RTP Telephony Event to/from the external network, see subclause 14.4.8 in 3GPP TS 23.231 [3], or:
- select default PCM codec towards the SIP-I CS CN and exclude the RTP Telephony Event in the reply to the preceding (3GPP SIP-I) node and then no inband DTMF detection/insertion is required.

4.4.3 DTMF support in SDP offer received from External SIP-I network

If an IWU receives an SDP offer from the external SIP-I network with the RTP Telephony Event it shall forward the RTP Telephony Event in the offer to the succeeding node. If the SDP answer from the succeeding (3GPP internal) SIP-I node includes the RTP Telephony Event the IWU shall configure its MGW to relay the RTP Telephony Events transparently as described in subclause 14.4.3 of 3GPP TS 23.231 [3].

If an IWU receives a SDP offer from the external SIP-I network without the RTP Telephony Event the IWU shall include the RTP Telephony Event in the offer to the succeeding node if any codec other than the default PCM speech codec is offered to the succeeding node. If only the default PCM speech codec is offered to the succeeding node, the IWU may include the RTP Telephony Event in the offer to the succeeding SIP-I CS CN node.

If the IWU receives a SDP answer from the succeeding (3GPP internal) SIP-I node including the RTP Telephony Event and the RTP Telephony Event had not been received in the offer from the external network the IWU returns the default PCM codec in the SDP answer to the external SIP-I network. The IWU shall then request its MGW (UP-IWU) to detect any inband DTMF from the external SIP-I network and signal the DTMF to the succeeding 3GPP SIP-I node within the RTP Telephony Event and insert DTMF tones into the external SIP-I network if DTMF digits received via RTP Telephony Event from the succeeding 3GPP SIP-I node, see subclause 14.4.8 in 3GPP TS 23.231 [3].

If an IWU receives a SDP answer from the succeeding (3GPP internal) SIP-I node excluding the RTP Telephony Event (i.e. default PCM codec selected) but received an RTP Telephony Event in the SDP offer from the external SIP-I

network it may return RTP Telephony Event in the SDP answer to the external SIP-I network. It shall then configure its MGW (UP-IWU) for transferring DTMF between inband PCM and RTP Telephony Events as described in subclause 14.4.8 in 3GPP TS 23.231 [3]. If the IWU chooses not to include the RTP Telephony Event in the SDP answer then default PCM codec shall be signalled in the SDP answer to the external SIP-I network. No inband DTMF detection or insertion is required; any DTMF tones received are passed transparently inband.

If an IWU receives a SDP answer from the succeeding (3GPP internal) SIP-I node excluding the RTP Telephony Event (i.e. default PCM codec selected) and did not receive an RTP Telephony Event in the SDP offer from the external SIP-I network the IWU returns the default PCM codec as the selected codec in the SDP answer to the external network and shall not request its MGW to configure RTP Telephony Event; therefore any inband DTMF tones are passed transparently inband.

4.5 User Plane Interworking

4.5.1 General

Figure 4.5.1.1 shows the user plane protocol stacks within the external SIP-I network and the 3GPP SIP-I based circuit switched core network.

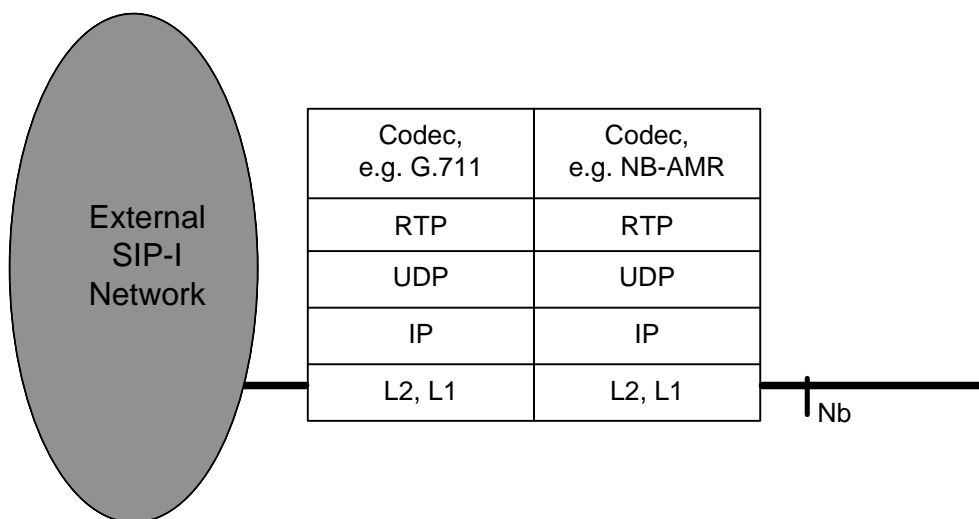

Figure 4.5.1.1: user plane interworking

If the same speech codec is used on both sides, no speech transcoding is required.

4.5.2 DTMF Interworking

For general information of DTMF interworking, see subclause 4.4.1.

The IWU may configure its UP-IWU with RTP Telephony Event at the 3GPP SIP-I termination and the external SIP-I termination. The UP-IWU shall then relay any DTMF received within the RTP Telephony Event Payload Type from one network interface to the other.

The IWU may configure the UP-IWU with only one network termination with RTP Telephony Event and the other termination configured for default PCM. The UP-IWU shall then detect DTMF tones from the PCM-encoded speech path and transmit them as RTP Telephony Events toward the other network and shall detect RTP Telephony Events and insert the DTMF as Tones in the corresponding PCM-encoded path.

If the IWU does not configure RTP Telephony Event on either network terminations then the UP-IWU simply relays the PCM-encoded speech from one network to the other (which may contain and therefore relay DTMF tones).

If RTP Telephony Event is selected for either the external SIP-I connection or for the internal 3GPP CS CN connection, but not for both, then the MGW shall filter out (delete) the DTMF from the default PCM-coded speech path (when relaying the DTMF via the RTP Telephony Event) to prevent potential double signalling of the same digit if a later insertion back to inband DTMF tone transmission were to occur.

The related UP-IWU control procedures and UP-IWU behaviour is described in subclauses 14.4.3 and 14.4.8 of 3GPP TS 23.231 [3], where the MGW shall be understood as UP-IWU.

4.6 Example Call flows

4.6.1 General

In this subclause call flows are shown as examples to demonstrate the signalling interworking of the IWU. Within the message sequence charts some content of the messages are shown in order to visualise some of the important interworking aspects, which were described in previous subclauses of this document. It is to be noted that the intention is neither to show the complete content of the SIP messages nor to use the exact syntax of SIP and SDP messages as it is defined in the respective RFCs. It is also not the intention to show all alternative options that are possible for a certain call flow.

4.6.2 Incoming Call flows

4.6.2.1 Incoming Call – no preconditions in external network

Figure 4.6.2.1.1 shows a terminating call where the external network does not indicate the support of preconditions and where the SDP body contains a list of codecs according to IETF RFC 3264 [22]. The IWU assumes that remote preconditions are met. The incoming side RTP bearer termination is yet not successfully reserved and configured and therefore local preconditions are not met. Thus the IWU initiates precondition signalling when sending the INVITE request to the succeeding 3GPP node. The IWU and the 3GPP node perform codec negotiation according to 3GPP rules as specified in 3GPP TS 23.153 [5]. The IWU answers to the external network with a single selected codec. If possible the selected codec is the same as received from the 3GPP node to avoid transcoding at the network border.

The IWU changes the content of the Request URI (either a tel-URI or a SIP-URI with "user=phone") from the MSISDN of the called subscriber to the MSRN received from the HLR. The IWU inserts its own address into the From header of the initial SIP INVITE request being sent to the succeeding 3GPP node.

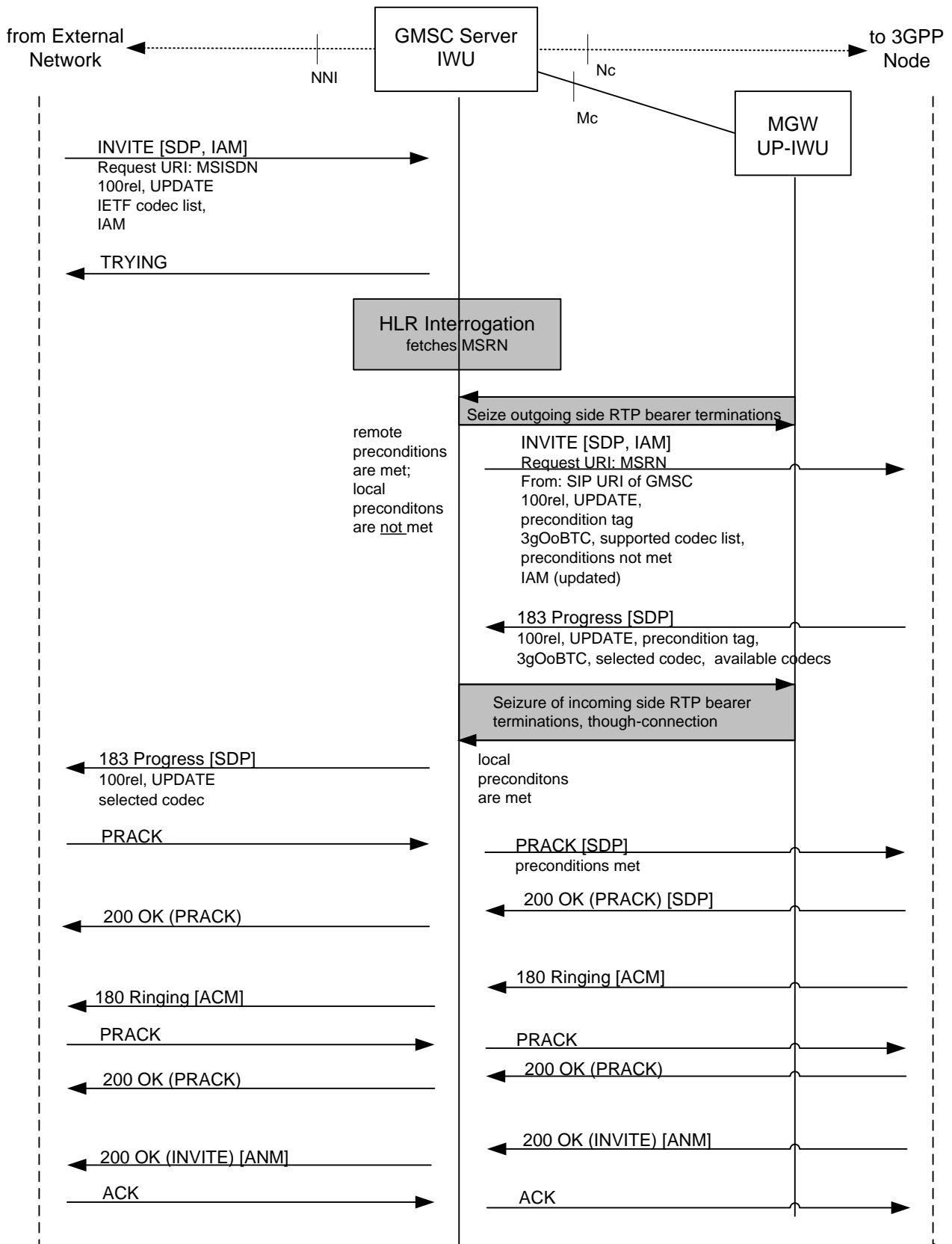
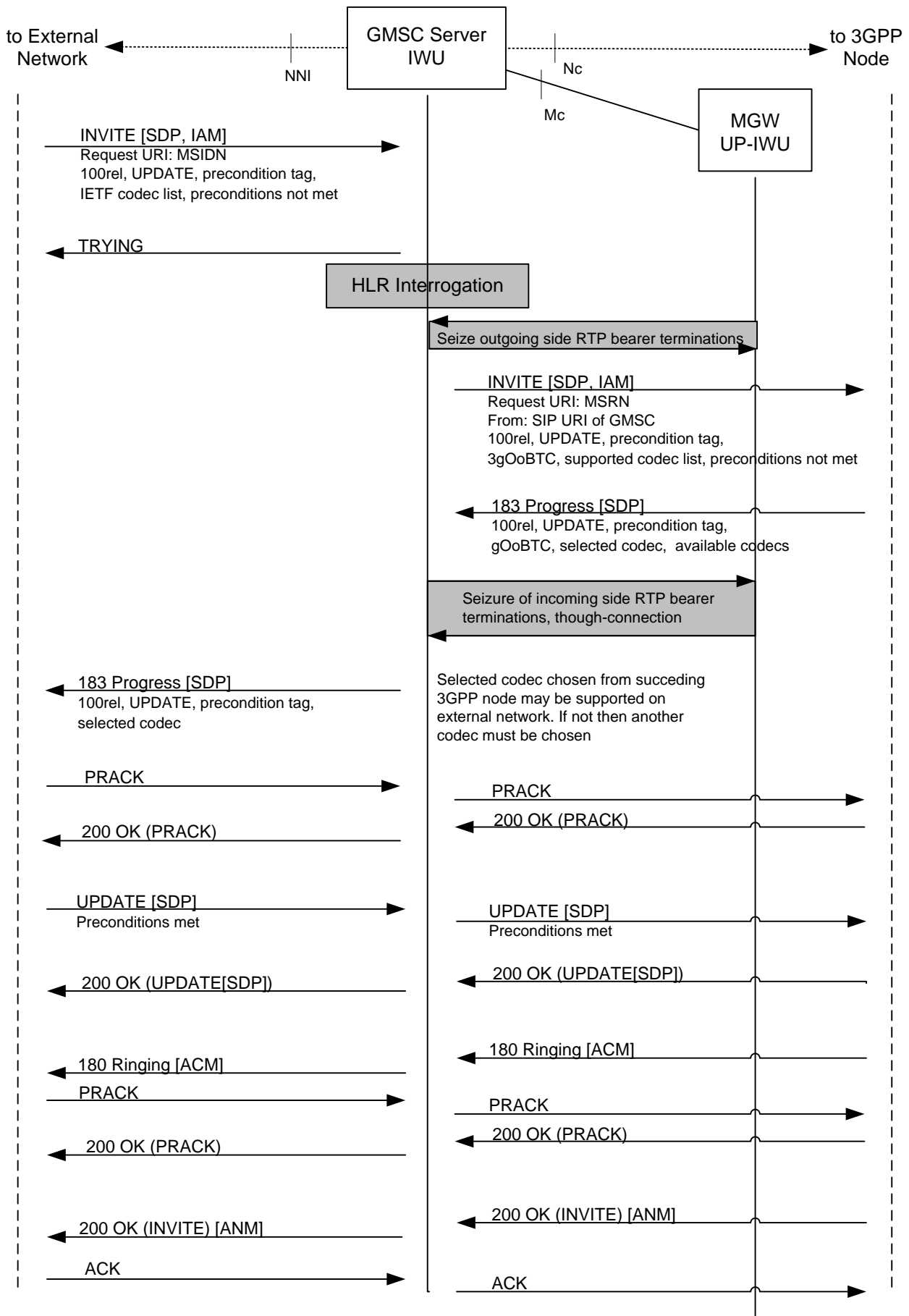

Figure 4.6.2.1.1: Incoming Call (message sequence chart), example without support for preconditions at the NNI

4.6.2.2 Incoming Call with preconditions not met

In figure 4.6.2.2.1 the external network indicates that its preconditions are not met. Because support for preconditions is mandated at the interface to the succeeding 3GPP node, the IWU can immediately send the INVITE towards the destination.

The IWU receives from the external network the information that preconditions are met either in the PRA CK or UPDATE request, where the SDP parameters are set accordingly. The IWU sends the information that preconditions are met either within the PRA CK or with an UPDATE request to the 3GPP node such that the called subscriber can be alerted.



**Figure 4.6.2.2.1: Incoming Call (message sequence chart),
example with precondition update**

4.6.3 Outgoing Call flows

4.6.3.1 Outgoing Call with support for preconditions

Figure 4.6.3.1.1 shows an outgoing call where the preconditions are not met when the IWU receives the initial SIP INVITE. Support for preconditions is confirmed from the external network. Within this example the external node provides a single codec, therefore no second SDP offer/answer is needed for codec negotiation.

When the IWU receives from the preceding 3GPP node that preconditions are met, then it informs the external node that called subscriber can be alerted with an UPDATE request, where the SDP contains the appropriate precondition offer and the selected codec.

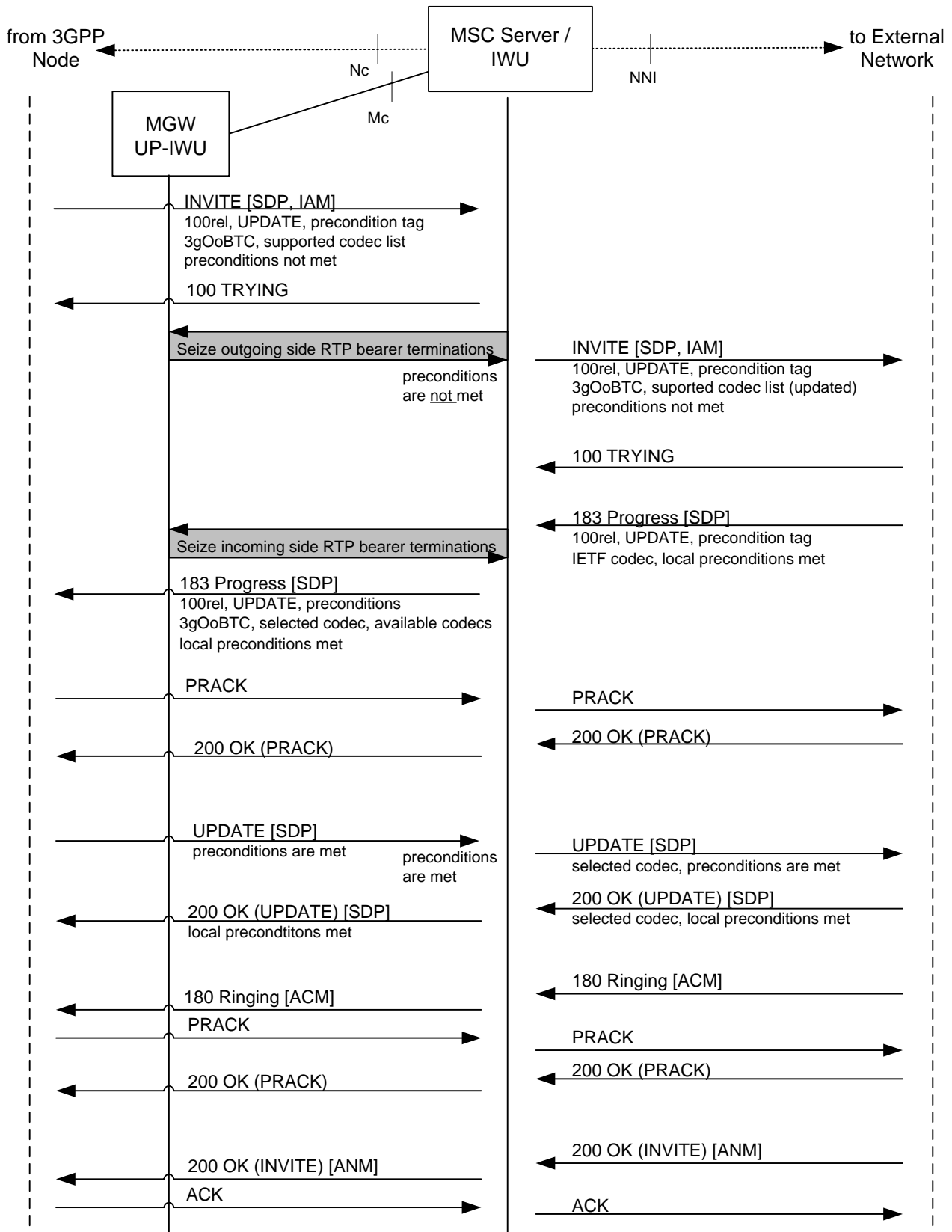

Figure 4.6.3.1.1: Outgoing call (message sequence chart), example with support for preconditions

4.6.3.2 Outgoing Call with support of 100rel but no support for preconditions

Figure 4.6.3.2.1 depicts an outgoing call where the external network supports reliable provisional responses and the UPDATE method but does not support preconditions. Therefore the IWU cannot exchange SDP precondition offers/answers with the external node.

In this example the IWU receives more than one single codec in the 183 Progress from the external node. Therefore the IWU selects one of the received codecs and makes a second SDP offer to the external node in the PRA CK in order to lock the codec.

The IWU receives a 180 Ringing provisional response from the external network before preconditions are fulfilled. The IWU forwards the 180 Ringing response after preconditions have been fulfilled.

NOTE 1: The IWU may also have received a successful final response to the INVITE before preconditions have been met. In this case the forwarding of the 180 Ringing response and of the final successful response towards the preceding 3GPP node is delayed until preconditions are fulfilled.

NOTE 2: As an alternative the IWU could send PRA CK to the external node when PRA CK is received from the preceding 3GPP node acknowledging the 180 Ringing response. Since the sending of the 180 Ringing response to the 3GPP network may be delayed, this may lead to the retransmission of 180 Ringing response sent by the external node.

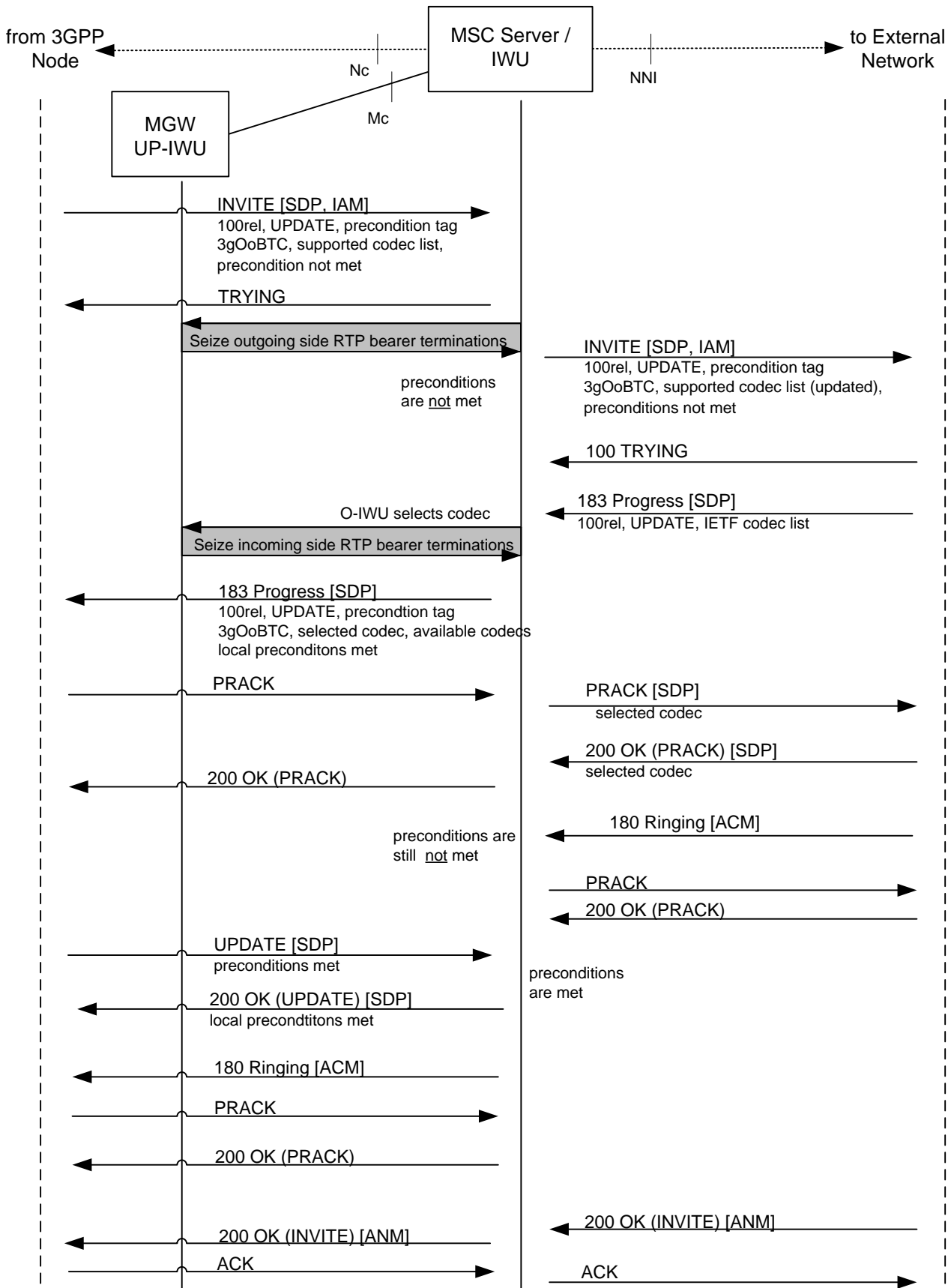

Figure 4.6.3.2.1: Outgoing Call (message sequence chart), example with support of 100rel but no support for preconditions

4.6.3.3 Outgoing Call without support for 100rel and preconditions

Figure 4.6.3.3.1 depicts an outgoing call where the external network does not support reliable provisional responses and therefore no SDP precondition signalling can be performed with the UPDATE method. With the 183 Progress the IWU receives an IETF codec list "unreliably". If the answer includes more than one codec the IWU cannot make a second offer to the external node (to lock the selected codec) during the early dialogue. However, the IWU can make use of the received information and start codec negotiation when forwarding the 183 Progress to the preceding 3GPP node.

The IWU immediately sends 200 OK to PRA CKs received from the 3GPP node, because it cannot forward them to the external node. The reliable provisional responses cannot be signalled end-to-end.

The final response from the external network should include the same codecs as received previously within the Progress message. If this answer includes more than one codec the IWU makes a second offer to the external network with a re-INVITE request.

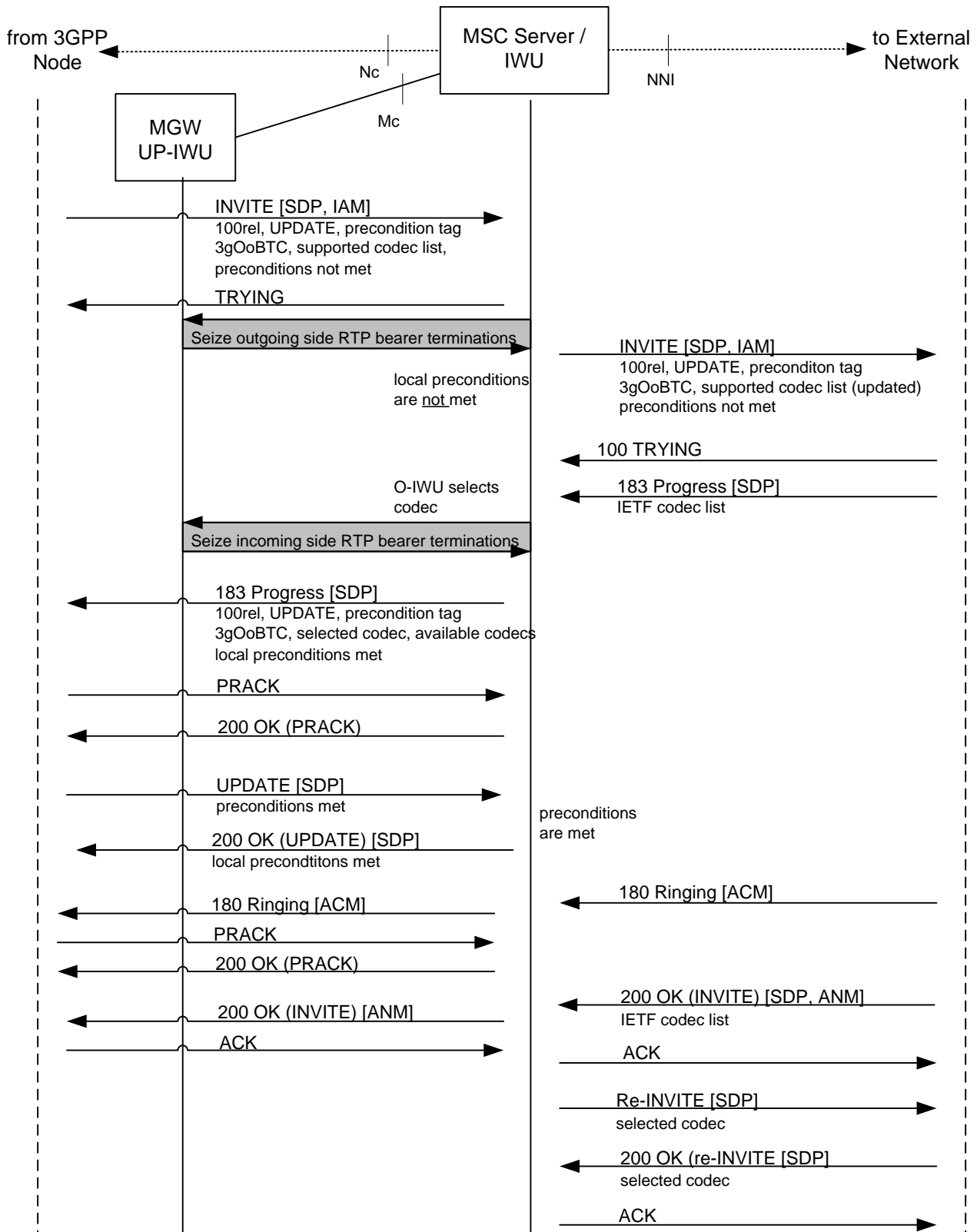
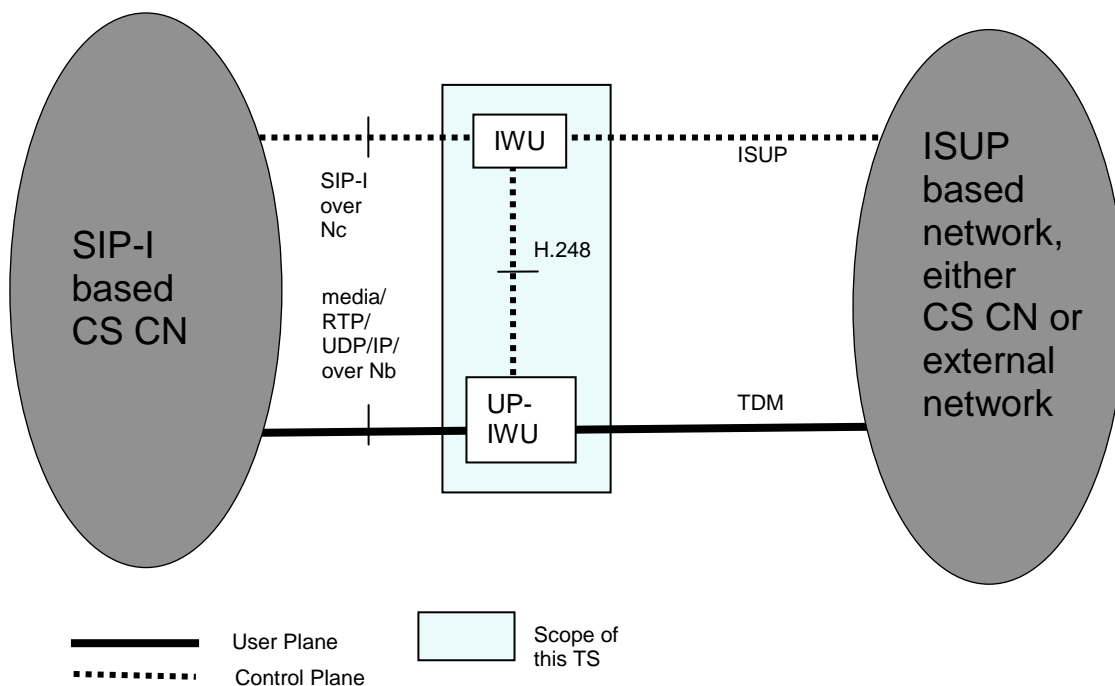

Figure 4.6.3.3.1: Outgoing Call (message sequence chart), example without support for 100rel and preconditions

5 Interworking between a SIP-I based circuit-switched core network and an ISUP based network

5.1 Reference Model

Figure 5.1.1 details the interworking reference model for subclause 5 of the present specification



NOTE: The IWU is a logical function that may reside with other 3GPP logical functions in the same physical nodes, e.g. in an (G)MSC Server. The figure shows only the logical separation.

Figure 5.1.1: interworking reference model

Nb reference point: The Nb reference point is defined in accordance with 3GPP TS 29.414 [43].

Nc reference point: The Nc reference point is defined in accordance with 3GPP TS 29.231 [4].

5.2 Control Plane Interworking

The following subclauses define the signalling interworking between the ISDN User Part (ISUP) protocols and Session Initiation Protocol (SIP) with its associated Session Description Protocol (SDP) and encapsulated ISUP at an IWU.

The IWU shall act as a Type A or Type B exchange (ITU-T Recommendation Q.764 [7]) for the purposes of ISUP compatibility procedures.

NOTE: An IWU may apply additional procedures to support interworking for national-specific capabilities.

The ISUP capabilities or signalling information defined for national use are outside the scope of the present document.

The services that can be supported through the use of the signalling interworking are limited to the services that are supported both within the ISUP based network and the SIP-I based CS CN. The IWU will originate and/or terminate services or capabilities that do not interwork seamlessly across domains according to the relevant protocol recommendation or specification.

Table 5.2.1 lists the services seamlessly interworked within the scope of the present document.

Table 5.2.1: Seamlessly interworked Services

Service
Speech/3.1 kHz audio
Data Calls (optional)
En bloc address signalling
Out of band transport of DTMF tones and information. (BICC only)
Inband transport of DTMF tones and information. (BICC and ISUP)
Multiple Subscriber Number (MSN)
Calling Line Identification Presentation (CLIP)
Calling Line Identification Restriction (CLIR)
Connected line presentation (COLP)
Connected line restriction (COLR)
Call Hold
Call Forwarding
Explicit Call Transfer (ECT)
User-to-User Signalling (UUS)
Call Deflection (CD)
Closed User Group (CUG)
Completion of Calls to Busy Subscriber (CCBS)
Multi-Level Precedence and Pre-emption (MLPP)
Call Waiting

The subclause 5.3.2 of ITU-T Recommendation Q.1912.5 [6] describes additional general principles specific to SIP-I.

The interworking procedures in subclauses 5.3, 5.4 and 5.4 are based on ITU-T Recommendation Q.1912.5 [6] profile C. Clarifications are made within this specification on the application of ITU-T Recommendation Q.1912.5 [6] profile C.

The control plane between the ISUP network and the SIP-I based CN is as shown in figure 5.2.1.

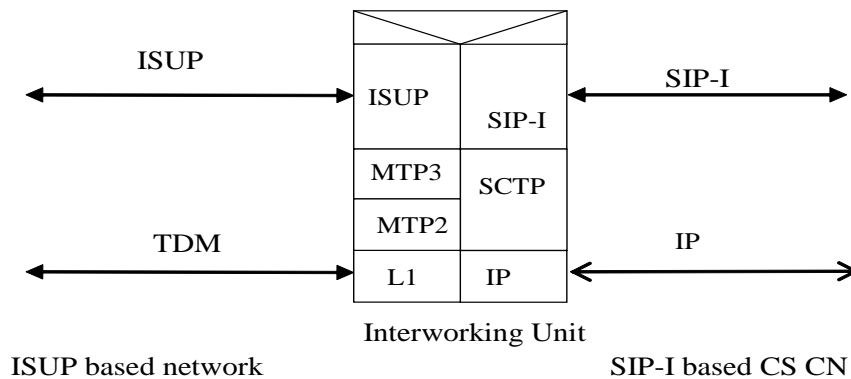

Figure 5.2.1: Control plane interworking between a SIP-I based circuit-switched core network and an ISUP based network

5.3 Signalling Interworking of a Call from the ISUP based network towards the SIP-I based circuit-switched core network

5.3.1 General

The procedures for Profile C in clause 7 of ITU-T Recommendation Q.1912.5 [6] shall be applied with the modifications provided in this subclause.

5.3.1.1 Sending of ISUP information to adjacent SIP nodes

The IWU receiving ISUP information shall apply any interworking procedures detailed in clause 7 of ITU-T Recommendation Q.1912.5 [6] affecting parameters within the ISUP, and then proceed to encapsulate any ISUP information received (with the exception of the excluded messages detailed in 5.4.3 of ITU-T Recommendation Q.1912.5 [6]) in a SIP message in a MIME body according to IETF RFC 3204 [19]. SIP Header fields relating to the handling of the ISUP body shall be set as specified in subclause 5.4.1.2 of ITU-T Recommendation Q.1912.5 [6].

NOTE 1: The text in the preceding paragraph has been derived from ITU-T Recommendation Q.1912.5 [6], subclause 5.4.1.

For a basic call setup, the SIP message used to encapsulate the ISUP message shall be the SIP message that was first triggered to be sent from the IWU as a result of the interworking specified in clause 7 of ITU-T Recommendation Q.1912.5 [6]. As an example, this means that an ISUP IAM will be encapsulated within the INVITE message that is sent out from the IWU. For the ISUP messages listed in table 1 of ITU-T Recommendation Q.1912.5 [6], the special procedures in subclause 5.4.3 of ITU-T Recommendation Q.1912.5 [6] are applicable.

NOTE 2: The text in the preceding paragraph has been derived from ITU-T Recommendation Q.1912.5 [6], subclause 5.4.1.3.

5.3.1.2 Receipt of encapsulated ISUP information within SIP-I

On receipt of a SIP message containing encapsulated ISUP, the IWU shall de-encapsulate the ISUP message from the SIP message body. The received SIP message shall be mapped to an ISUP message and merged with the de-encapsulated ISUP information according to the rules in clause 7 of ITU-T Recommendation Q.1912.5 [6].

NOTE 1: The text in the preceding paragraph has been derived from ITU-T Recommendation Q.1912.5 [6], subclause 5.4.2.

NOTE 2: These precedence rules have been derived from the following principles, which can also be applied for any ISUP information not covered by the present specification:

- 1 Where a SIP header mapping to ISUP field(s) is possible (for example the mapping of Request-URI to Called Party Number), the SIP header is given precedence over the encapsulated ISUP value in the alignment process. (Conflicts can be caused by a possible service invocation within the SIP network.)
- 2 De-encapsulated ISUP information overrides ISUP information derived from default values (rather than SIP information).
- 3 Local ISUP procedures may modify information derived from SIP or default values.

This Note has been derived from text in ITU-T Recommendation Q.1912.5 [6], subclause 5.4.2

NOTE 3: There is a certain change against ITU-T Recommendation Q.1912.5 [6], where the above note is formulated as normative procedures. However, this is very high level and not required if you look at the real interworking procedures later on. Therefore formulating this as a Note makes much more sense.

5.3.1.3 Special procedures related to outgoing INVITE

5.3.1.3.1 Overlap Signalling

The IWU does not need to support procedures related to overlap signalling in clause 7 of ITU-T Recommendation Q.1912.5 [6].

NOTE: No overlap signalling is used in a 3GPP CS domain. A G-MSC acting as IWU will collect all digits required to identify the called party and not propagate the overlap signalling further.

5.3.1.3.2 Coding of encapsulated ISUP IAM parameters in outgoing INVITE

The IWU may choose to transcode media, or attempt to interwork media without transcoding. If the IWU transcodes, it should set the TMR/USI/HLC parameters according to the codec applied in the SIP-I network. Otherwise, it should provide the TMR/USI/HLC parameters as received in the incoming IAM. If the IWU offers several codecs within SDP, it should set the TMR/USI/HLC parameters according to the preferred codec, applying the rules above for this codec.

NOTE: ITU-T Recommendation Q.1912.5 [6] does not describe the relationship between TMR/USI/HLC and SDP codec negotiation.

5.3.1.3.3 Media offered in SDP of outgoing INVITE

The IWU should offer codecs known to be supported within the SIP-I based CS CN network. If multiple speech codecs are offered, Out of Band Transcoder Control (OoBTC) procedures shall be applied by the IWU in accordance with 3GPP TS 23.153 [5]. Otherwise only the default PCM speech codec shall be signalled in an SDP offer; auxiliary payload types such as the Telephony Event RTP payload type may be included in addition.

If the IWU applies the optional "optimised MGW selection" procedure, it shall include a MGW Identifier in the SDP. Related signalling procedures are described in subclause 4.4 of 3GPP TS 23.231 [3] and the encoding of the MGW Identifier is defined in 3GPP TS 29.231 [4].

5.4 Signalling Interworking of a Call from SIP-I based circuit-switched core network towards the ISUP based network

5.4.1 General

The procedures for Profile C in clause 6 of ITU-T Recommendation Q.1912.5 [6] shall be applied with the modifications provided in this subclause.

5.4.2 Interworking of received ISUP messages to SIP messages

The IWU receiving backwards ISUP information shall apply any interworking procedures detailed in clause 6 of ITU-T Recommendation Q.1912.5 [6] affecting parameters within the ISUP, and then proceed to encapsulate any ISUP information received (with the exception of the excluded messages detailed in 5.4.3 of ITU-T Recommendation Q.1912.5 [6]) in a SIP message in a MIME body according to IETF RFC 3204 [19]. The selected SIP Header fields relating to the handling of the ISUP body shall be set as specified in subclause 5.4.1.2 of ITU-T Recommendation Q.1912.5 [6].

5.4.3 Interworking of received SIP messages to ISUP messages

5.4.3.1 Receipt of encapsulated ISUP information within SIP

On receipt of a SIP message containing encapsulated ISUP, the IWU shall de-encapsulate the ISUP message from the SIP message body. The received SIP message shall be mapped to an ISUP message and merged with the de-encapsulated ISUP message according to the rules for Profile C in clause 6 of ITU-T Recommendation Q.1912.5 [6].

NOTE 1: These precedence rules have been derived from the following principles, which can also be applied for any ISUP information not covered by the present specification:

- 1 Where a SIP header mapping to ISUP field(s) is possible (for example the mapping of Request-URI to Called Party Number), the SIP header is given precedence over the encapsulated ISUP value in the alignment process.
- 2 De-encapsulated ISUP information overrides ISUP information derived from default values (rather than SIP information).
- 3 Local ISUP procedures may modify information derived from SIP or default values.

This note has been derived from text in ITU-T Recommendation Q.1912.5 [6], subclause 5.4.2.

NOTE 2: There is a certain change against ITU-T Recommendation Q.1912.5 [6], where the above note is formulated as normative procedures. However, this is very high level and not required if you look at the real interworking procedures later on. Therefore formulating this as a note makes much more sense.

5.4.3.2 Special Procedures for the Reception of SIP INVITE request

5.4.3.2.1 Propagation of overlap signalling toward the 3GPP CS domain

The procedures in clause 6 of ITU-T Recommendation Q.1912.5 [6] related to the propagation of overlap signalling are not applicable, since no overlap signalling is used within the CS CN.

5.4.3.2.2 Derivation of TMR, USI and HLC parameters within sent IAM message

The IWU may choose to transcode media and shall then set the parameters according to the coding applied within the CS Domain. Otherwise, the IWU shall select a codec for the SIP side termination using SDP offer-answer procedures, IETF RFC 3264 [22], and shall map the SDP information of this codec to the TMR/USI/HLC parameters according to table 2a of 3GPP TS 29.163 [13]. If the information derived from this mapping matches the information in the TMR/USI/HLC parameters in the encapsulated ISUP, the TMR/USI/HLC parameters from the encapsulated ISUP should be used as they may contain additional information. If the information derived from this mapping contradicts the information in the TMR/USI/HLC parameters in the encapsulated ISUP, the TMR/USI/HLC parameters derived by the mapping shall be used.

NOTE: The procedures in this note are an amendment compared to ITU-T Recommendation Q.1912.5 [6], which simply states the TMR parameters in encapsulated ISUP shall take precedence, However this is inappropriate if an incompatible codec is selected.

5.4.3.2.3 Receipt of SIP INVITE without SDP offer

An IWU may reject receipt of SIP INVITE without SDP offer, otherwise the procedures in section 4.2.2.3 shall be followed.

NOTE: A SIP INVITE without SDP offer is not used within the CS CN.

5.4.3.2.4 Special Procedures for deferred MGW selection procedure.

If the IWU supports the optional "deferred MGW selection" procedure and receives an unspecified connection address in the SDP offer contained in the INVITE request, it should include a MGW Identifier for the IWU-UP it selects in the corresponding SDP answer. Related signalling procedures are described in subclause 4.4 of 3GPP TS 23.231 [3] and the encoding of the MGW Identifier is defined in 3GPP TS 29.231 [4].

5.5 Supplementary services

5.5.1 Special procedures for supplementary service interworking

The supplementary services described in table 5.2.1 are interworked by using the parameters of the (de)encapsulated ISUP. No other interworking is required, except if otherwise described within the subclauses below.

5.5.2 Interworking of CLIP/CLIR supplementary service

For the interworking of call towards the SIP-I based CS CN: the service shall be supported by encapsulation.

For the interworking of call from the SIP-I based CS CN: ITU-T Recommendation Q.1912.5 [6], Annex B.1, shall apply.

5.5.3 Interworking of Call Hold (HOLD) supplementary service

The Profile C procedures in ITU-T Recommendation Q.1912.5 [6], subclause B.10, shall be followed.

5.5.4 Interworking of Completion of Calls to Busy Subscriber (CCBS) supplementary service to SIP networks

The Profile C procedures of ITU-T Recommendation Q.1912.5 [6], subclause B.11 shall be applied.

5.6 User Plane Interworking

5.6.1 General

This subclause describes user plane issues including interworking of DTMF.

Figure 5.6.1.1 shows the user plane protocol stacks within the SIP-I based CS CN and an ISUP network.

Apart from speech codecs, data call related codecs, e.g. as listed in table 2a of 3GPP TS 29.163 [13], may be used.

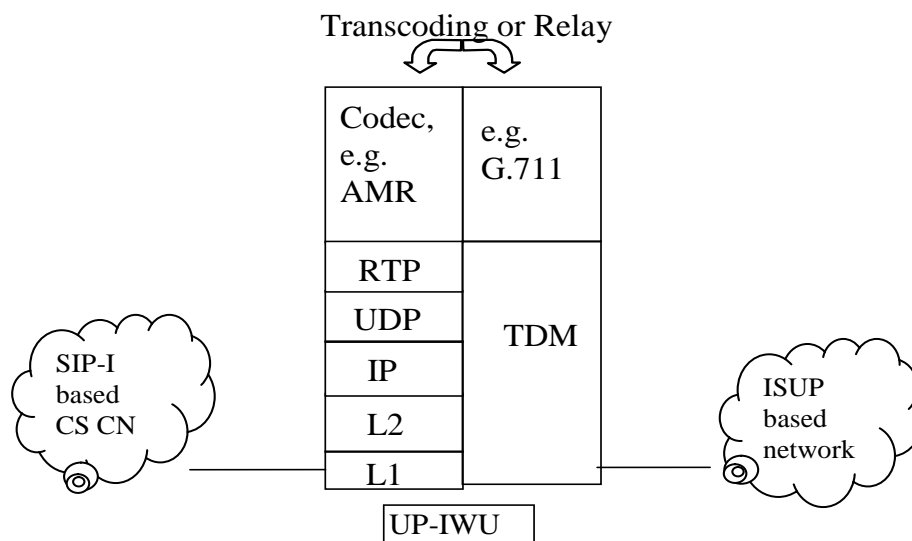

Figure 5.6.1.1: User Plane Interworking and ISUP based CS Domain

5.6.2 DTMF

If RTP Telephony Event is selected by the 3GPP CS CN the MGW shall filter out (delete) the DTMF from the default PCM codec when relaying the DTMF via the RTP Telephony Event to prevent potential double signalling of the same digit if a later insertion back to inband PCM transmission were to occur.

5.7 Example Call flows

The call flow examples in ITU-T Recommendation Q.1912.5 [6] Appendix III are applicable with the following exceptions for the reasons specified:

- III.2.1.1 En bloc, subscriber free indication – flow does not include use of reliable provisional response within the SIP-I network
- III.2.1.2 En bloc, early ACM – flow does not include use of reliable provisional response within the SIP-I network
- III.2.1.3 En bloc, early media scenario – flow does not include use of reliable provisional response within the SIP-I network
- III.2.1.4 En bloc, simple segmentation procedures – flow does not include use of reliable provisional response within the SIP-I network
- III.2.1.10 Overlap signalling – 3GPP G-MSC will collect all digits before continuing the call
- III.2.2.1 Backward release during call setup – flow does not include use of reliable provisional response within the SIP-I network

6 Interworking between a SIP-I based circuit-switched core network and a BICC based network

6.1 Reference Model

Figure 6.1.1 details the interworking reference model for clause 6 of the present specification

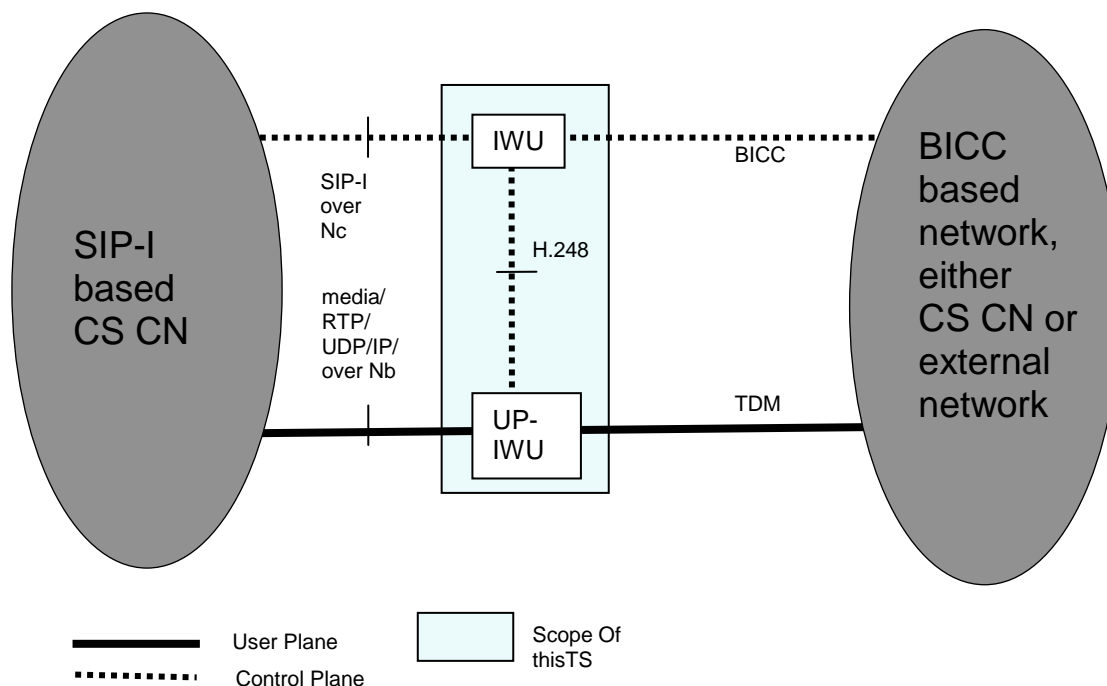

NOTE: The IWU is a logical function that may reside with other 3GPP logical functions in the same physical nodes, e.g. in an (G)MSC Server. The figure shows only the logical separation.

Figure 6.1.1: interworking reference model

Nb reference point: The Nb reference point is defined in accordance with 3GPP TS 29.414 [43].

Nc reference point: The Nc reference point is defined in accordance with 3GPP TS 29.231 [4].

6.2 Control Plane Interworking

6.2.1 General

The following subclauses define the signalling interworking between the Bearer Independent Call Control (BICC) protocol (see ITU-T Recommendation Q.1902.1 to Q.1902.6 [8]) and the Session Initiation Protocol (SIP) with its associated Session Description Protocol (SDP) and encapsulated ISUP at an IWU.

The IWU shall act as a Type A or Type B exchange (ITU-T Recommendation Q.764 [7]) for the purposes of ISUP compatibility procedures.

The BICC capabilities or signalling information defined for national use are outside the scope of the present document.

NOTE: An IWU may apply additional procedures to support interworking for national-specific capabilities.

The services that can be supported through the use of the signalling interworking are limited to the services that are supported both within the BICC based network and the SIP-I based CS CN. The IWU will originate and/or terminate services or capabilities that do not interwork seamlessly across domains according to the relevant protocol recommendation or specification.

Table 5.2.1 in subclause 5.2 lists the services seamlessly interworked within the scope of the present document.

The subclause 5.3.2 of ITU-T Recommendation Q.1912.5 [6] describes additional general principles specific to SIP-I.

The interworking procedures in the subclauses 6.3 and 6.4 are based on ITU-T Recommendation Q.1912.5 [6] profile C. Clarifications are made within this specification on the application of ITU-T Recommendation Q.1912.5 [6] profile C. Specific rules for handling of the APM mechanism have been added, which are not specified in ITU-T Recommendation Q.1912.5 [6].

6.2.2 Signalling interactions between network entities in the control plane

The control plane between a SIP-I based CS core networks and a BICC based network, where the underlying signalling transport is either IP or ATM respectively, is shown in figures 6.2.2.1 and 6.2.2.2.

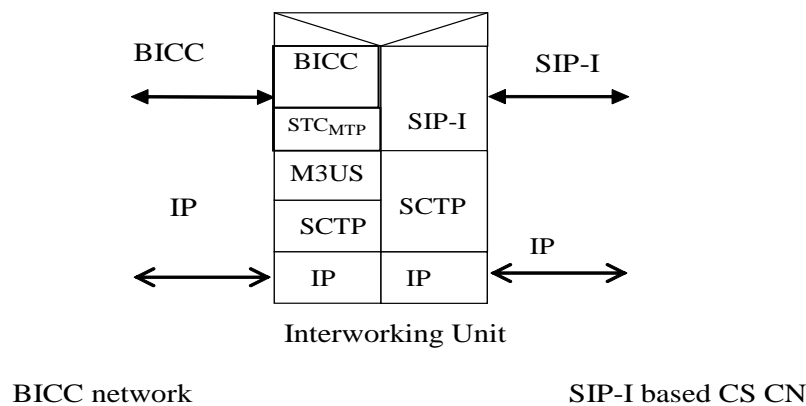

Figure 6.2.2.1: Control plane interworking between SIP-I based CS CN and a BICC based network with IP signalling transport

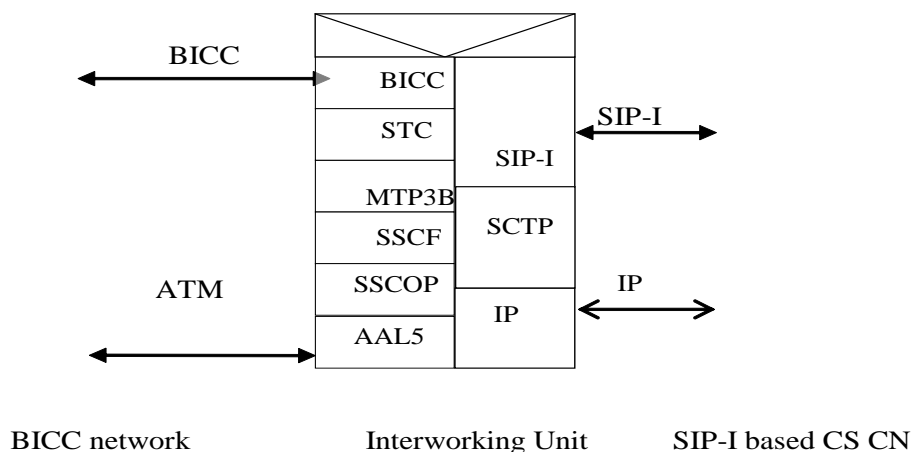

Figure 6.2.2.2: Control plane interworking between SIP-I based CS CN and a BICC based network with ATM signalling transport

Signalling between the SIP-I based CS CN and the Interworking Unit uses the services of IP (IETF RFC 791 [14] or IETF RFC 2460 [17]), SCTP (IETF RFC 4960 [18]) and SIP-I.

6.3 Signalling Interworking of a Call from the BICC based network towards the SIP-I based circuit-switched core network

The procedures in subclause 5.3 shall be applied with the modifications provided in the present subclause.

The text in subclause 5.3 is to be understood as follows:

- Where "ISUP" is mentioned, this shall be understood as BICC. As an exception, references to ISUP encapsulated within SIP-I shall be understood without modification, i.e. they still refer to ISUP rather than BICC.

If an IAM message is received, the APM information elements (see ITU-T Recommendation Q.765 [27]) relating to the BICC APM user (see ITU-T Recommendation Q.765.5 [28]) shall be removed before the IAM message is encapsulated in the triggered SIP INVITE message.

An APM message received from the CS side (see ITU-T Recommendation Q.765 [27]) that relates to the BICC APM user (see ITU-T Recommendation Q.765.5 [28]) shall not be encapsulated in any triggered SIP message.

6.4 Signalling Interworking of a Call from SIP-I based circuit-switched core network towards the BICC based network

The procedures in subclause 5.4 shall be applied with the modifications provided in the present subclause.

The text in subclause 5.4 is to be understood as follows:

- Where "ISUP" is mentioned, this shall be understood as BICC. As an exception, references to ISUP encapsulated within SIP-I shall be understood without modification, i.e. they still refer to ISUP rather than BICC.

An APM message received from the BICC side (see ITU-T Recommendation Q.765 [27]) that relates to the BICC APM user (see ITU-T Recommendation Q.765.5 [28]) shall not be encapsulated in any triggered SIP message.

6.5 Supplementary services

The procedures in subclause 5.5 shall be applied.

6.6 Codec Negotiation between a BICC based network and a SIP-I based circuit-switched core network

6.6.1 General

The procedures in Annex B of 3GPP TS 29.163 [13] shall be applied with the modifications provided in the following subclauses.

The text in Annex B of 3GPP TS 29.163 [13] is to be understood as follows:

- Where "MGCF" is mentioned, this shall be understood as IWU.
- Where "IM-MGW" is mentioned, this shall be understood as UP-IWU.
- Where "IM CN subsystem" is mentioned, this shall be understood as SIP-I based circuit-switched core network.

The offer/answer procedures of the Session Description Protocol (SDP) for media negotiation shall be applied as specified in 3GPP TS 29.231 [4].

6.6.2 Codec Negotiation from SIP-I on Nc to BICC Network

6.6.2.1 Sending of IAM

When the IWU receives an initial INVITE request with SDP offer containing a codec list with the 3GPP_OoBTC_Indicator, the procedures defined for a 3GPP node terminating SDP offer in clause 9 of 3GPP TS 23.153 [5] shall be applied. The IWU shall follow the procedures of subclause B.2.5 of 3GPP TS 29.163 [13] to create a Supported Codec List for transmission in the outgoing IAM.

6.6.2.2 Sending of SDP Answer

When the IWU receives the backward codec information, it shall apply the procedure defined in the subclause B.2.1.2 of 3GPP TS 29.163 [13] and shall create the SDP answer in accordance with the procedures defined for a 3GPP node terminating SDP offer in clause 9 of 3GPP TS 23.153 [5].

6.6.2.3 Mid-call Codec Negotiation initiated from SIP-I on Nc

When the mid-call codec negotiation is initiated from the SIP-I based CS CN side the IWU:

- shall apply the procedures defined for a 3GPP node terminating SDP offer in clause 9 of 3GPP TS 23.153 [5] for the SIP-I based CS CN side, and
- shall apply the procedures from the subclause B.2.3 of 3GPP TS 29.163 [13] for the BICC network side.

6.6.3 Codec Negotiation from BICC Network to SIP-I on Nc

6.6.3.1 Sending of initial SDP Offer

When the IWU receives an IAM, the IWU shall follow the procedures of subclause B.2.5 of 3GPP TS 29.163 [13] to convert the Supported Codec List from the IAM into an SDP offer for transmission in the outgoing INVITE request. When generating the initial SDP offer, the IWU shall apply the procedures defined for a 3GPP node originating SDP offer in clause 9 of 3GPP TS 23.153 [5].

6.6.3.2 Responding to Serving Node initiating Codec Negotiation

When the IWU receives the SDP answer it shall select a codec configuration for the SIP-I based CS CN side in accordance with clause 9 of 3GPP TS 23.153 [5]. For the BICC network side the IWU shall apply the procedure defined in the subclause B.2.2.2 of 3GPP TS 29.163 [13].

6.6.3.3 Mid-call Codec Negotiation initiated from BICC

When the mid-call codec negotiation is initiated from the BICC side the IWU:

- shall apply the procedures from the subclause B.2.4 of 3GPP TS 29.163 [13] for the BICC network side, and
- shall apply the procedures defined for a 3GPP node originating SDP offer in clause 9 of 3GPP TS 23.153 [5] for the SIP-I based CS CN side.

6.7 DTMF Signalling Interworking applicable for all Calls between a BICC network and a SIP-I based circuit-switched core network

6.7.1 General

DTMF signalling via the RTP telephony-event is mandated to be supported over the Nb interface for SIP-I based Circuit Switched Core Network on Nc Interface, see 3GPP TS 23.231 [3]. However it is an option to use this transmission method when only the default PCM codec selected.

BICC over Nc supports both inband DTMF and DTMF via OoB signalling within the BICC APM, see 3GPP TS 23.205 [9]. If OoBTC is supported then use of OoB DTMF is mandated, see 3GPP TS 23.153 [5]. External BICC networks may also transport DTMF either inband or via OoB signalling within the BICC APM.

If the usage of the RTP Telephony Event has been negotiated within the SIP-I based CS CN, the IWU shall configure this payload type at the UP-IWU.

6.7.2 DTMF transfer from SIP-I on Nc to BICC network (Out-of-Band DTMF)

If RTP Telephony Event has been selected for the 3GPP SIP-I CS CN and OoB DTMF transmission is required in the succeeding BICC network the IWU shall use the Detect DTMF procedure to request the MGW to report DTMF Digits as described in subclause 14.4.6 of 3GPP TS 23.231 [3], i.e. RTP Telephony Event is configured in addition to the Detect DTMF Event. An example for the interworking with explicit duration reporting in BICC is shown in figure 6.7.2.1.

NOTE 1: If the implicit duration is reported via the BICC Out Of Band procedure it can result in the duration being shorter than the original duration of the DTMF received at the MGW and even shorter than the minimum duration required by 3GPP TS 23.014 [24].

An example for the interworking with implicit duration reporting in BICC is shown in figure 6.7.2.2.

NOTE 2: Support of "start of DTMF detection" is optional for the MGW (UP-IWU).

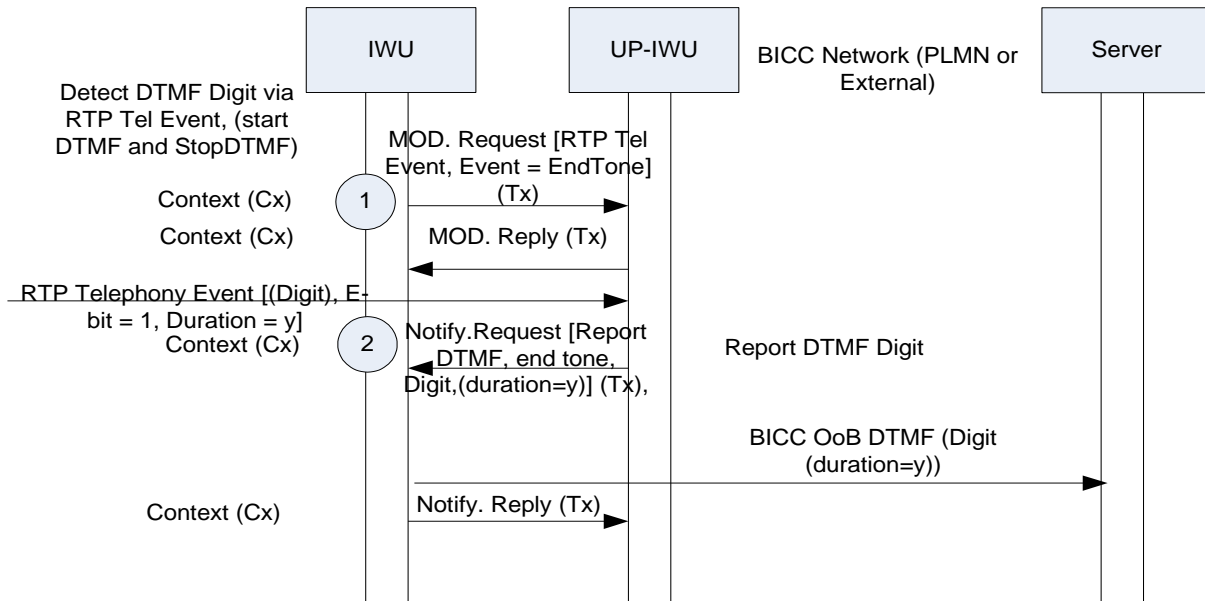

Figure 6.7.2.1: DTMF interworking: SIP-I to BICC, explicit duration (message sequence chart)

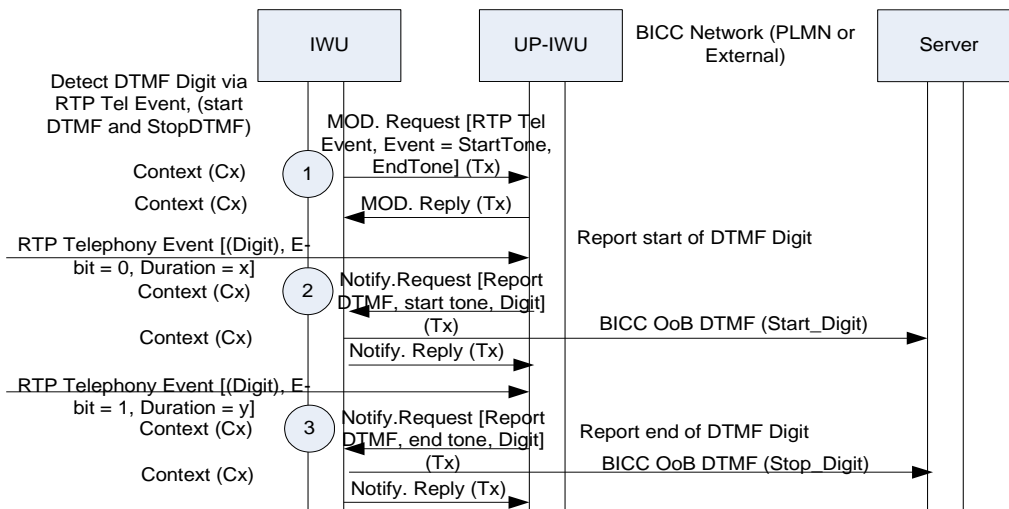

Figure 6.7.2.2: DTMF interworking: SIP-I to BICC, implicit duration (message sequence chart)

If RTP Telephony Event has not been selected on 3GPP SIP-I CS CN interface and OoB DTMF is required in the BICC network the IWU shall request inband DTMF detection as described in subclause 14.4.2.1 of 3GPP TS 23.205 [9], i.e. the RTP Telephony Event is not configured. The same principles apply for signalling implicit or explicit DTMF digits.

6.7.3 DTMF transfer from BICC network (Out-of-Band DTMF) to SIP-I on Nc

If RTP Telephony Event has been selected for the 3GPP SIP-I CS CN and OoB DTMF transmission is selected in the succeeding BICC network the IWU shall use the "Send DTMF" procedure and may use the "Stop DTMF" procedures to request the MGW to play out DTMF to the IM CN subsystem whenever it receives out-of-band DTMF indications from the BICC network.

The UP-IWU (MGW) shall signal the RTP Telephony event(s) in accordance with subclause 14.4.4 of 3GPP TS 23.231[3].

If implicit DTMF timing is deployed (as shown in example message sequence chart in figure 6.7.3.1) and the MGW has already completed the digit transmission it shall not take any action upon the reception of the Stop DTMF procedure.

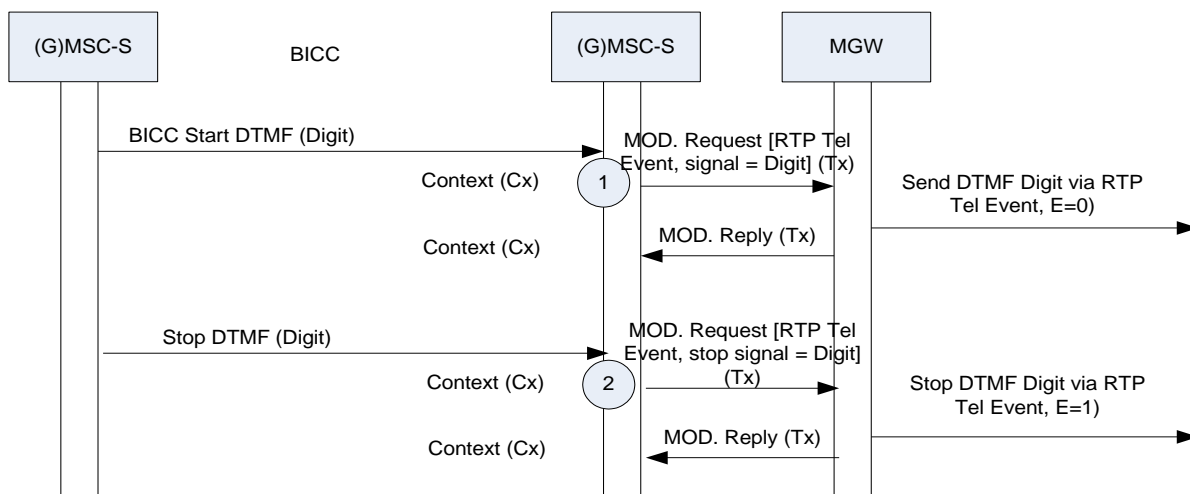

Figure 6.7.3.1: DTMF Interworking: BICC to SIP-I, implicit duration (message sequence chart)

6.7.4 SIP-I on Nc interworking with BICC for Inband DTMF

The interworking between inband and out-of-band transport shall be performed according to subclause 14.4.8 in 3GPP TS 23.231 [3], if required.

If the RTP Telephony event has not been negotiated within the SIP-I based CS CN, the interworking MSC towards a BICC network with inband DTMF transport shall not configure the RTP Telephony event at the attached MGW. The MGW will then transfer DTMF within the speech codec without detecting it.

6.8 User Plane Interworking

6.8.1 General

This subclause describes user plane issues including interworking of DTMF.

6.8.2 DTMF Interworking

If RTP Telephony Event is selected for the internal 3GPP CS CN connection and inband DTMF is selected for the BICC network the MGW shall filter out (delete) the DTMF from the default PCM codec when relaying the DTMF via the RTP Telephony Event to prevent potential double signalling of the same digit if a later insertion back to inband PCM transmission were to occur.

6.9 Example Call flows

See subclause 5.7.

7 Interworking between a SIP-I based circuit-switched core network and the IP Multimedia (IM) Core Network (CN) Subsystem

7.1 Reference Model

7.1.1 General

Figure 7.1.1.1 details the reference model required to support interworking between the 3GPP IM CN subsystem, as specified in 3GPP TS 23.228 [11] and 3GPP TS 24.229 [12] and a SIP-I based circuit-switched core network, as specified in 3GPP TS 23.231 [3] and 3GPP TS 29.231 [4].

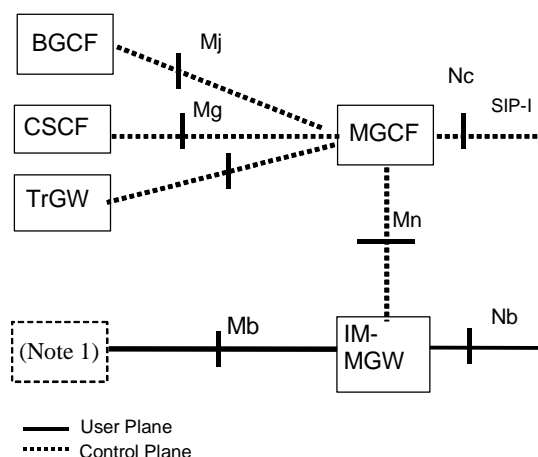

NOTE 1: The IM-MGW may be connected via the Mb to various network entities, such as a UE (via a GTP Tunnel to a GGSN), an MRFP, or an application server.

Figure 7.1.1.1: IM CN subsystem to CS network logical interworking reference model

Nb reference point: The Nb reference point is defined in accordance with 3GPP TS 29.414 [43].

Nc reference point: The Nc reference point is defined in accordance with 3GPP TS 29.231 [4].

Mg reference point: The Mg reference point is defined in accordance with 3GPP TS 24.229 [12].

Mj reference point: The Mj reference point is defined in accordance with 3GPP TS 24.229 [12].

Mb reference point: The Mb reference point is defined in accordance with 3GPP TS 23.002 [2].

Mn reference point: The Mn reference point is defined in accordance with 3GPP TS 29.332 [54].

7.1.2 Signalling interactions between network entities in the control plane

The control plane between the IM CN Subsystem supporting SIP and a 3GPP CS network supporting a SIP-I based Nc interface is as shown in figure 7.1.2.

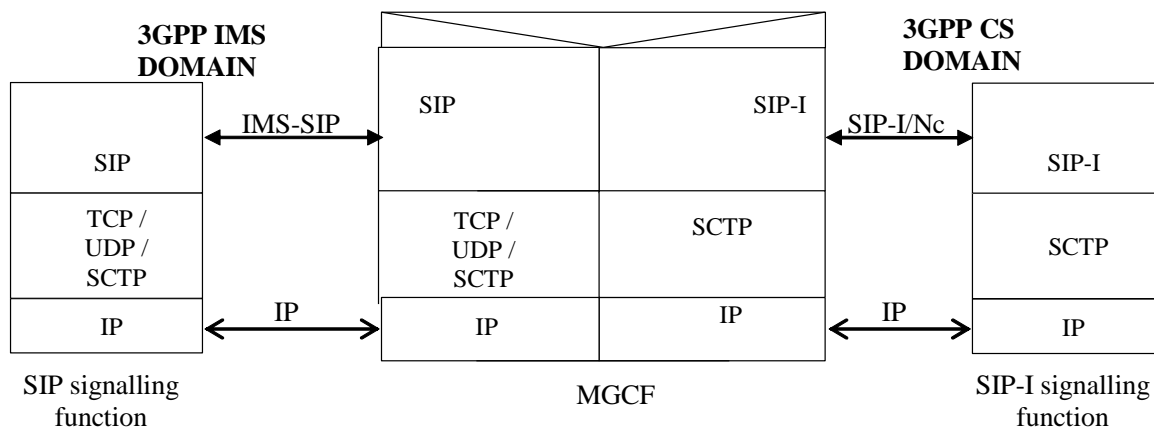

Figure 7.1.2.1: Control plane interworking protocol stack between the IM CN subsystem and a 3GPP CS network supporting SIP-I based Nc interface

Signalling between the SIP signalling function and the MGCF uses the services of IP (RFC 2460 [17]), and transport protocol such as TCP (RFC 793 [16]) or UDP (RFC 768 [15]) or SCTP (RFC 4960 [18]) (see 3GPP TS 24.229 [12]), and SIP.

Signalling between the SIP-I signalling function and the MGCF uses the services of IP (IETF RFC 791 [14] or IETF RFC 2460 [17]), SCTP (IETF RFC 4960 [18]) and SIP-I.

7.2 Signalling Interworking of a Call from the IP Multimedia Subsystem towards the SIP-I based circuit-switched core network

7.2.1 General

If not otherwise stated within this subclause the MGCF shall follow the below listed procedures for interworking incoming SIP calls:

Sending SIP messages to the succeeding SIP-I based circuit-switched core network:

- When an incoming SIP message is received from the preceding IMS node then the MGCF shall send this SIP message to the succeeding SIP-I based circuit-switched core network unless otherwise specified in the subclauses below.
- The MGCF shall only send SIP methods, SIP headers, SDP body contents and other bodies as permitted by the profile for SIP-I on Nc as defined in 3GPP TS 29.231 [4].
- The MGCF shall, if defined by 3GPP TS 29.163 [13], generate an ISUP message following 3GPP TS 29.163 [13] and include this ISUP message into the SIP message in a MIME body according to IETF RFC 3204 [19]. The Content-Type header field and the Content-Disposition header field shall be set as specified in subclause 5.4.1.2 of ITU-T Recommendation Q.1912.5 [6].

Sending SIP messages to the preceding IMS node:

- When the MGCF receives a SIP-I message from the succeeding SIP-I based circuit-switched core network then the MGCF shall send this message to the preceding IMS node unless otherwise specified in the subclauses below.
- The MGCF shall only send SIP methods, SIP headers, SDP body contents and other bodies which are permitted by the IMS profile as defined in 3GPP TS 24.229 [12].
- The MGCF shall construct IMS specific headers and bodies according to the procedures defined in 3GPP TS 29.163 [13].

7.2.2 Exceptions from forwarding received SIP messages

If call clearing is initiated either from the preceding IMS network or from the succeeding SIP-I based circuit switched core network then the MGCF shall apply the call clearing procedures as defined within 3GPP TS 23.231 [3] subclause 7.3.1.

When a BYE request, 4xx, 5xx or 6xx final response to an initial INVITE request is received from the succeeding SIP-I based circuit switched core network and if a Reason Header field was not received and encapsulated ISUP REL message is included, then the ISUP Cause value received in the encapsulated ISUP REL message shall be mapped into SIP Reason header fields as specified in 3GPP TS 29.163 [13]. If SIP message did not contain neither a Reason header nor encapsulated ISUP REL message, then a 4xx, 5xx, or 6xx final response shall be mapped to an ISUP cause value as specified in 3GPP TS 29.163 [13] table 18 or BYE request shall be mapped to cause value 16; this cause value shall be mapped into the SIP Reason header fields as specified in 3GPP TS 29.163[13].

When a SIP failure response to an initial INVITE request is to be sent to the preceding IMS node, the cause value contained in the Reason header to be sent shall be used to determine the SIP failure response code as specified in 3GPP TS 29.163 [13] table 9.

If different SIP methods are used within the SIP-I based circuit switched core network and within the IMS network for basic call signalling or supplementary service signalling, then the MGCF shall map the received SIP message into the appropriate SIP message of the network the message is sent to.

If the interworking procedures within 3GPP TS 29.163 [13] do not result in any mapping then the MGCF shall not send the SIP message, which is received either from the SIP-I based circuit switched core network or from the IMS network, towards the other side.

If the MGCF supports overlap signalling from the preceding IMS node and the first incoming SIP INVITE request does not provide a complete number, then the MGCF shall not forward this first SIP INVITE request and additional SIP INVITE requests or SIP INFO requests, which are used by the MGCF to collect all digits required to identify the called subscriber.

The MGCF shall generate 100 Trying provisional SIP responses to acknowledge the receipt of INVITE requests. The MGCF shall not forward received 100 Trying provisional SIP responses.

7.2.3 Sending SIP INVITE request

The MGCF may reject receipt of SIP INVITE without SDP offer. Otherwise the MGCF shall construct an SDP offer with contents according to local policy, e.g. SDP for a G.711 speech call, in accordance with the built encapsulated IAM message. In the constructed SDP offer the MGCF shall encode preconditions as not met.

NOTE 1: A SIP-I INVITE always includes an SDP offer within the CS CN.

The MGCF shall forward the SIP INVITE request with the SDP offer and encapsulate an IAM message after the reception of the SIP INVITE request irrespective of the status of local and remote preconditions:

When the incoming SIP INVITE request indicates that remote preconditions are not met or when local preconditions are not met then the MGCF shall include the tag "precondition" in the SUPPORTED header and shall encode preconditions in the SDP offer that the related local preconditions for QoS are not met.

If the incoming SIP INVITE request indicates that remote preconditions are met, or if the incoming SIP INVITE request does not contain a precondition tag, and if local preconditions are met then the MGCF may either not include the tag "precondition" and exclude appropriate SDP lines, or include the tag "preconditions" in the SUPPORTED header and provide an SDP offer indicating that preconditions are met.

NOTE 2: The use of SUPPORTED header is a deviation from IETF RFC 3312 [23] when the strength-tag contains a "mandatory" value.

NOTE 3: The setting of the "Continuity Check Indicator" in the "Nature of Connection Indicators" parameter within the encapsulated IAM is of no significance. The value is ignored by the succeeding node of the SIP-I based circuit-switched core network.

The MGCF shall not use the MGW bypass option, because some functions will not work as the succeeding SIP-I node does not know that it is interworking any IMS function. For example an incoming multi media call from IMS does not result in a CS multimedia telephony service on the SIP-I based circuit switched core network.

If the incoming SIP INVITE request does not provide a complete number, then the MGCF shall defer sending the SIP INVITE request until the MGCF has collected all digits required to identify the called subscriber. The additional digits may either, as a network option, be received in in-dialog SIP INFO requests or in additional SIP INVITE requests with the same Call-ID and From tag as a previous SIP INVITE. The MGCF shall apply the signalling procedures on the IMS side as specified in 3GPP TS 29.163 [13].

7.2.4 Updating Precondition Information

If the MGCF previously indicated to the succeeding SIP-I based circuit-switched core network that preconditions were not met, the MGCF shall send to the succeeding SIP-I based circuit-switched core network appropriate SDP lines indicating that local preconditions are met

- when the MGCF receives from the preceding IMS network SDP indication that preconditions are met and local preconditions are met,
- or when remote preconditions at the preceding IMS network were already met and local precondition status of the MGCF changes to be met.

NOTE: ISUP COT is not supported within SIP-I on Nc and therefore the ISUP COT message shall not be included into the SIP message.

7.2.5 SDP Codec Negotiation

When sending an SDP offer/answer to negotiate codecs with the succeeding SIP-I based circuit-switched core network the MGCF shall follow the procedures defined for a 3GPP Intermediate Node in clause 9 of 3GPP TS 23.153 [5].

When sending an SDP offer/answer to negotiate codecs with the preceding IMS network the MGCF shall send codec information in accordance to 3GPP TS 24.229 [12].

NOTE 1: Which codecs are negotiable with the IMS network may depend on operator choices and preferences (local policy).

7.2.6 MGW Selection

If the MGCF supports either the optional "Optimised MGW Selection" or the optional "Deferred MGW Selection" then the MGCF may include the SDP MGW Identifier into the SIP message being sent to the succeeding SIP-I based circuit switched core network in accordance to subclause 4.4 of 3GPP TS 23.231 [3].

Otherwise the MGCF shall seize a MGW and shall include the MGW connection address into the SDP offer of the initial SIP INVITE request it will send to the succeeding 3GPP SIP-I based circuit switched core network node.

7.2.7 Autonomous Release

For interworking towards the preceding IMS node the MGCF shall use the procedure as defined in 3GPP TS 29.163 [13].

For call clearing towards the succeeding SIP-I based circuit switched core network the MGCF shall use the procedures as defined within 3GPP TS 23.231 [3] subclause 7.3.

7.2.8 Further setting of SIP header values

The MGCF shall act as a B2BUA as defined in IETF RFC 3261 [20]. The MGCF shall terminate the incoming SIP session and the MGCF shall originate an outgoing SIP-I call towards the SIP-I based circuit switched core network. Therefore the MGCF shall generate the SIP headers and values of Cseq, Call-ID, Via, Record-Route, Route and Contact independently from the received SIP message. For the generation of the Request-URI of an initial INVITE request and header fields To, From, Max-Forwards, and P-Asserted-Identity the MGCF shall use the information received from the preceding IMS node and perform the procedures specified below.

The Request-URI of in-dialogue SIP requests will be populated with information received within the Contact header of previous responses according to SIP procedures. When sending a request towards the SIP-I based circuit switched core network the MGCF shall generate a From tag independent of the value received from the IMS. Furthermore, when

sending a response towards the IMS, the MGCF shall generate a To tag independent of the value received from the SIP-I based circuit switched core network.

The procedures for population of the Request-URI and header fields To, From, Max-Forwards, and P-Asserted-Identity are based on the mapping procedures specified in 3GPP TS 29.163 [13]. The text in 3GPP TS 29.163 [13] is to be understood as follows:

- Where ISUP called party number is mentioned, this shall be understood as internal ISUP called party number.
- Where ISUP calling party number is mentioned, this shall be understood as internal ISUP calling party number.
- Where ISUP Generic Number (additional calling party number) is mentioned, this shall be understood as internal Generic Number (additional calling party number).
- Where ISUP Hop Counter parameter is mentioned, this shall be understood as internal ISUP Hop Counter parameter.

NOTE: Only the userinfo component of the received SIP URI is used by mapping procedures according to 3GPP TS 29.163 [13] while the received host part is ignored and a new value is generated by the MGCF.

When sending an initial INVITE request towards the SIP-I based circuit switched core network the MGCF shall perform the following actions to generate the Request-URI and the To header field:

- Create an internal ISUP called party number from the received Request URI according to 3GPP TS 29.163 [13]. When Number Portability is supported the MGCF shall follow the procedures specified in subclause 7.2.3.1.2A of 3GPP TS 29.163 [13]. Otherwise the ISUP called party number is generated as specified in subclause 7.2.3.1.2.1 of 3GPP TS 29.163 [13].
- Generate the new Request-URI and the new To header field from the internal ISUP called party number according to 3GPP TS 29.163 [13]. When Number Portability is supported the MGCF shall follow the procedures specified in subclause 7.2.3.2.2A of 3GPP TS 29.163 [13]. Otherwise the Request-URI and the To header field are generated as specified in subclause 7.2.3.2.2.1 of 3GPP TS 29.163 [13].

When sending an initial INVITE request towards the SIP-I based circuit switched core network the MGCF shall perform the following actions to generate the P-Asserted-Identity and the From header fields:

- create an internal ISUP calling party number and an internal Generic Number (additional calling party number) as specified in subclauses 7.2.3.1.2.6 and 7.2.3.1.2.7 of 3GPP TS 29.163 [13]; and
- generate the new P-Asserted-Identity and the From header from the internal ISUP calling party number and the internal Generic Number (additional calling party number) as specified in subclause 7.2.3.2.2.3 of 3GPP TS 29.163 [13].

When sending the initial SIP INVITE request to the SIP-I based circuit-switched core network and if the Hop Counter procedure is supported in the SIP-I based circuit switched core network (national option), then the MGCF shall perform the following actions:

- create an internal ISUP Hop Counter parameter from the received Max-Forwards value according to subclause 7.2.3.1.2.9 of 3GPP TS 29.163 [13]; and
- either generate the new Max-Forwards value from the internal ISUP Hop Counter parameter by applying the rules in subclause 7.2.3.2.2.4 of 3GPP TS 29.163 [13] and decrementing the resulting value by one or forward the received Max-Forwards value decremented by one.

Otherwise if the MGCF forwards SIP request, it shall either set the Max-Forwards header to a default value or forward the received Max-Forwards value decremented by one.

When receiving any SIP request with a Max-Forwards field value of zero, and if request shall be propagated to the other side, the MGCF shall reject the request with a 483 (Too Many Hops) SIP final response, in accordance with IETF RFC 3261 [20].

7.3 Signalling Interworking of a Call from SIP-I based circuit-switched core network towards the IP Multimedia Subsystem

7.3.1 General

If not otherwise stated within this subclause the MGCF shall follow the below listed procedures for interworking outgoing SIP calls:

Sending SIP messages to the succeeding IMS node:

- When the MGCF receives a SIP-I message from the preceding SIP-I based circuit-switched core network then the MGCF shall send this message to the succeeding IMS network unless otherwise specified in the subclauses below.
- The MGCF shall only send SIP methods, SIP headers, SDP body contents and other bodies which are permitted by the IMS profile as defined in 3GPP TS 24.229 [12].
- The MGCF shall construct IMS specific headers and bodies according to the procedures defined in 3GPP TS 29.163 [13].

NOTE 1: This implies that if the incoming SIP-I message contained an encapsulated ISUP message then the ISUP message is removed from the forwarded SIP message. But the ISUP information may be mapped into a PSTN XML body, if supported as a network option.

- Within IMS the initial INVITE request may be routed to a forking proxy. The MGCF shall be ready to receive responses generated due to a forked request and behave according to the procedures specified in IETF RFC 3261 [20] and subclause 7.3.9 of the present specification.

NOTE 2: The multiple early dialogues are not propagated to the preceding SIP-I based circuit-switched core network.

NOTE 3: The MGCF does not, itself, perform forking.

Sending SIP messages to the preceding SIP-I based circuit switched core network:

- When the MGCF receives a SIP message from the succeeding IMS node then the MGCF shall send this SIP message to the preceding SIP-I based circuit-switched core network unless otherwise specified in the subclauses below.
- The MGCF shall only send SIP methods, SIP headers, SDP body contents and other bodies as permitted by the profile for SIP-I on Nc as defined in 3GPP TS 29.231 [4].
- The MGCF shall, if defined by 3GPP TS 29.163 [13], construct an ISUP message following 3GPP TS 29.163 [13] and include this ISUP message into the SIP message in a MIME body according to IETF RFC 3204 [19]. The Content-Type header field and the Content-Disposition header field shall be set as specified in subclause 5.4.1.2 of ITU-T Recommendation Q.19.12.5 [6].
- When sending an encapsulated ISUP ACM message or ISUP CPG message the MGCF shall follow the procedures defined within 3GPP TS 29.163 [13] for the handling of the ring tone and therefore may request the IM-MGW to send ring tone in the backwards direction.

7.3.2 Exceptions from forwarding received SIP messages

If call clearing is initiated either from the succeeding IMS node or from the preceding SIP-I based circuit switched core network then the MGCF shall apply the call clearing procedures as defined within 3GPP TS 23.231[3] subclause 7.3.1.

When a BYE request is sent to the succeeding IMS node and if a Reason Header field was not received, then the received ISUP Cause value being received in the encapsulated ISUP REL message shall be mapped into SIP Reason header fields as defined by 3GPP TS 29.163 [13].

When a BYE request, 4xx, 5xx or 6xx final response to an initial INVITE request is received from the succeeding IMS Node and the SIP message did not contain a Reason header, then a 4xx, 5xx, or 6xx final response shall be mapped to an ISUP cause value as specified in 3GPP TS 29.163 [13] table 18 or BYE shall be mapped to cause value 16; this cause value shall be included in the encapsulated ISUP REL messages as specified in 3GPP TS 29.163[13].

When a SIP failure response to an initial INVITE request is to be sent to the preceding SIP-I node, the cause value contained in the encapsulated ISUP REL message to be sent shall be used to determine the SIP failure response code as specified in 3GPP TS 29.163 [13] table 9.

If different SIP methods are used within the SIP-I based circuit switched core network and within the IMS network for basic call signalling or supplementary service signalling, then the MGCF shall map the received SIP message into the appropriate SIP message of the network the message is sent to.

The MGCF shall modify the SDP it forwards to include local address information from the IM-MGW and to adjust the codec information if the IM-MGW is configured to transcode.

The MGCF shall not forward the received 100 Trying provisional SIP responses, and shall generate 100 Trying provisional SIP responses to acknowledge the receipt of INVITE requests.

If the MGCF defers sending an INVITE request until preconditions are met (see subclause 7.6.3.1), the MGCF shall reply to the INVITE request from the SIP-I based CS CN with a 183 Session Progress provisional response and shall not forward the subsequent PRACK and UPDATE requests from the SIP-I based CS CN, but reply with a final response to the received request. When the MGCF then receives from the preceding SIP-I based circuit-switched core network an SDP indication that preconditions are met and local preconditions are met, the MGCF shall forward to the succeeding IMS node the previously received INVITE request with appropriate SDP lines indicating that local preconditions are met. If MGCF then receives a 183 Session Progress provisional response, it shall either:

- not forward this provisional response and acknowledge the receipt with a PRACK request toward the IMS; or
- if defined by 3GPP TS 29.163 [13], construct an ISUP message and include this ISUP message into the 183 Session Progress provisional response in a MIME body and remove the SDP answer from the 183 Session Progress provisional response and forward it toward the SIP-I based CS CN.

7.3.3 Sending SIP INVITE request

When the MGCF receives an incoming SIP INVITE request the MGCF shall ignore the value of the Continuity Check indicator in the Nature of Connection Indicators parameter in the included IAM. If the incoming SIP INVITE request indicates that remote preconditions are not met or when local preconditions are not met then the MGCF should defer sending the INVITE request until remote and local preconditions are met.

NOTE: This recommendation follows 3GPP TS 29.163 [13] to avoid clipping and other obstacles, when the receiving IMS terminal does not support SIP preconditions and the SIP UPDATE method.

As an option, instead of following the above procedure, the MGCF may include the tag "precondition" in the SUPPORTED header and encode preconditions in the SDP offer that the related local preconditions for QoS are not met.

7.3.4 Updating Precondition Information

If the MGCF previously indicated to the succeeding IMS node that preconditions were not met and a provisional response from the succeeding node indicated support for preconditions, then the MGCF shall send to the succeeding IMS node appropriate SDP lines indicating that local preconditions are met

- when the MGCF receives from the preceding SIP-I based circuit-switched core network an SDP indication that preconditions are met and local preconditions are met,
- or when remote preconditions at the preceding SIP-I based circuit-switched core network were already met and local precondition status of the MGCF changes to be met.

For each early SIP dialogue for which a provisional response has been received from the succeeding node indicating support for preconditions the MGCF, using an UPDATE or a PRACK request, shall send a confirmation that all the required preconditions have been met. This applies regardless of whether the early SIP dialogue existed prior to the preconditions being met or is subsequently created. The MGCF shall not interwork more than one 200 OK response to

an UPDATE request sent in multiple early dialogues, and should select the 200 OK response for the early dialogue for which the resources at the IM-MGW are configured (see subclause 7.3.9.2) for interworking.

A 580 Precondition Failure response might be received from the succeeding IMS node as a response either to the INVITE request, to the UPDATE request or to the PRACK request. All early dialogues are considered terminated upon reception of the 580 Precondition Failure response to the INVITE request. The MGCF shall release the call in accordance with 3GPP TS 29.163 [13], which also defines the coding of the REL message with Cause Code '127 Interworking' to be sent to the SIP-I based circuit-switched core network. The MGCF shall encapsulate the REL message into the 500 Server Internal Error response and send it to the SIP-I based circuit-switched 3GPP core network.

Upon reception of the 580 Precondition Failure response to the UPDATE or to the PRACK request within early dialogue MGCF shall immediately send a BYE request to terminate this early dialogue. Only if there is no more early dialogues, the MGCF shall encapsulate the REL message with Cause Code '127 Interworking' into the 500 Server Internal Error response and send it to the SIP-I based circuit-switched 3GPP core network.

7.3.5 Receipt of SIP redirect (3xx) response

When receiving a SIP response with a response code 3xx, the default behaviour of the MGCF is to release the call, where the MGCF sends to the preceding SIP-I based circuit-switched core network 480 Temporarily unavailable and encapsulate an ISUP REL message with a cause code value 127 (Interworking unspecified).

NOTE 1: The MGCF may also decide for example to redirect the call towards the URIs in the Contact header field of the response as an operator option, but such handling is outside of the scope of the present document.

NOTE 2: Above default behaviour and Note 1 is adopted from 3GPP TS 29.163 [13].

7.3.6 SDP Codec Negotiation

When sending an SDP offer/answer to negotiate codecs with the succeeding IMS network the MGCF shall send codec information in accordance with 3GPP TS 24.229 [12].

When sending an SDP offer/answer to negotiate codecs with the preceding SIP-I based circuit-switched core network the MGCF shall follow the procedures defined for a 3GPP Intermediate Node in clause 9 of 3GPP TS 23.153 [5].

NOTE: Which codecs are negotiable with the IMS network may depend on operator choices and preferences (local policy).

If the MGCF received an SDP answer without the OoBTC Indicator and multiple codecs from the IMS, and initiates a second offer toward the IMS in accordance with the procedures for a 3GPP Intermediate Node in clause 9 of 3GPP TS 23.153 [5], the MGCF shall:

- if it added the SDP offer to a SIP message received from the SIP-I based CS CN (e.g. a PRACK), remove the SDP answer from the corresponding response before sending it to the SIP-I based CS CN; and
- if it created a new SIP message (e.g. UPDATE or re-INVITE) to send the SDP offer to the IMS, not forward the SIP message with the SDP answer (e.g. a 200 OK) to the SIP-I based CS CN.

If the MGCF receives from the IMS due to forking for one SDP offer multiple SDP answers in provisional SIP responses of different early dialogues, the MGCF shall only interwork the first SDP answer and the MGCF shall not include any SDP answers in any subsequent SIP early responses it decides to forward.

If the MGCF sends an SDP offer within multiple UPDATE requests for different early dialogues towards the IMS side, it will receive an SDP answer in the response to each UPDATE request and the MGCF shall not interwork more than one 200 OK response to an UPDATE request sent in multiple early dialogues, and should select the 200 OK response for the early dialogue for which the resources at the IM-MGW are configured (see subclause 7.3.9.2) for interworking.

7.3.7 MGW Selection

If the MGCF supports either the optional "Optimised MGW Selection" or the optional "Deferred MGW Selection" then the MGCF shall not send a SDP MGW Identifier towards the succeeding IMS network. The MGCF shall seize an IM-MGW and shall then include the connection address in the SDP offer of the initial SIP INVITE request it will send to the succeeding IMS node.

If the MGCF supports the optional "deferred MGW selection" procedure and receives an unspecified connection address in the SDP offer contained in the SIP INVITE request, it should include an MGW_Identifier for the IM-MGW it selects in the corresponding answer. The encoding of the MGW_Identifier is defined in 3GPP TS 29.231[4].

The MGCF shall not use the "MGW bypass" option.

7.3.8 Autonomous Release

For interworking towards the succeeding IMS node the MGCF shall use the procedure as defined in 3GPP TS 29.163 [13].

For call clearing towards the preceding SIP-I based circuit switched core network the MGCF shall use the procedures as defined within 3GPP TS 23.231[3] subclause 7.3 for call clearing towards the originating side.

7.3.9 Handling of forked SIP Responses

7.3.9.1 SIP Dialogues

The MGCF shall inspect the tag in the 'To' header field of a non-100 provisional and a 2xx final responses in accordance to SIP procedures specified in IETF RFC 3261 [20] to identify the SIP dialogue the response belongs to. If responses belonging to different dialogues are received, the initial INVITE request has been forked.

7.3.9.2 Reception of non-100 provisional Responses to initial INVITE

Since the MGCF does not know that forking has occurred until a second non-100 provisional response creating a new early dialogue arrives the MGCF shall request the bearer resources as required by the first received SDP answer.

For each subsequent non-100 provisional response within a new early dialogue that is received, the MGCF shall apply the following procedures:

- Depending on the requirements in the SDP answer and the presence of P-Early-Media header the MGCF may either refrain from reconfiguring the IM-MGW, or it may use the Configure IMS Resources procedure.
- The MGCF shall construct an ISUP message in accordance to 3GPP TS 29.163 [13], and send it within the SIP message to the SIP-I based circuit-switched 3GPP core network. The MGCF shall use only one SIP dialogue within the SIP-I based circuit-switched 3GPP core network, and the MGCF shall thus supply the same 'To' header field in all SIP responses relating to a call it sends towards the SIP-I based circuit-switched 3GPP core network.
- However, the MGCF may refrain from sending additional subsequent non-100 provisional response to the SIP-I based CS CN if they do not contain any new information compared to the last previous non-100 provisional response it sent towards the SIP-I based CS CN.
- If the MGCF already received an SDP answer in a previous non-100 provisional response within another early dialogue (and thus forwarded the SDP answer), the MGCF shall not include the SDP answers in any subsequent non-100 provisional response it decides to send towards the SIP-I based CS CN.
- The MGCF shall send a PRACK request to the IMS to acknowledge the receipt of the subsequent non-100 provisional response. The MGCF will receive a response to the PRACK and shall not forward this response to the SIP-I based CS CN.
- If multiple codecs were contained in the provisional response, the MGCF shall include an SDP offer with the codec configured at the IM-MGW within the PRACK request.

7.3.9.3 Reception of final Responses to initial INVITE

Upon reception of a non-2xx final response to initial INVITE all early dialogues are considered terminated. The MGCF shall acknowledge it with an ACK request. In addition the MGCF shall create an encapsulated REL message as described in 3GPP TS 29.163 [13] and shall send it within a non-2xx final response (initial INVITE) to the SIP-I based circuit-switched 3GPP core network.

When a first 2xx final response is received for one of the early dialogues or when a received 2xx final response to an INVITE creates a new dialogue, the MGCF shall acknowledge it with the ACK request. If the remote IMS resources configured at the IM-MGW do not match the remote resources selected for the confirmed dialogue MGCF shall require updating the allocated resources. In addition the MGCF shall create an encapsulated ANM or CON message as described in 3GPP TS 29.163 [13] and shall send it within a final 200 OK response to the initial INVITE to the SIP-I based circuit-switched 3GPP core network. If the previously negotiated codecs in the SIP-I based CS CN differ from the remote resources selected for the confirmed dialogue, to avoid transcoding the MGCF should construct a new SDP offer based upon those remote resources and send it to the SIP-I based CS CN within an UPDATE or re-INVITE request.

Upon the reception of a subsequent final 2xx response for any further dialogue for an INVITE request due to forking, the MGCF shall:

- 1) acknowledge the response with the ACK request; and
- 2) send a BYE request to this dialogue in order to terminate it.

The INVITE transaction is completed 64*T1 seconds after the reception of the first 2xx response. At this point the MGCF shall terminate all early dialogs that have not been already transitioned to confirmed or terminated state.

7.3.10 Further setting of SIP header values

The MGCF shall act as a B2BUA as defined in IETF RFC 3261 [20]. The MGCF shall terminate the incoming SIP-I session and the MGCF shall originate an outgoing SIP session towards the succeeding IMS node. Therefore the MGCF shall generate the SIP headers and values of Cseq, Call-ID, Via, Record-Route, Route and Contact independently from the received SIP-I message. For the generation of the Request-URI of an initial INVITE requests and header fields To, From, Max-Forwards, and P-Asserted-Identity the MGCF shall use the information received from the SIP-I based circuit switched core network node and perform the procedures specified below.

The Request-URI of in-dialogue SIP requests will be populated with information received within the Contact header of previous responses according to SIP procedures. When sending a request towards the IMS the MGCF shall generate a From tag independent of the value received from the SIP-I based circuit switched core network. Furthermore, when sending a response towards the SIP-I based circuit switched core network, the MGCF shall generate a To tag independent of the value received from the IMS.

The procedures for population of the Request-URI and header fields To, From, Max-Forwards, and P-Asserted-Identity are based on the mapping procedures specified in 3GPP TS 29.163 [13]. The text in 3GPP TS 29.163 [13] is to be understood as follows:

- Where ISUP called party number is mentioned, this shall be understood as internal ISUP called party number.
- Where ISUP calling party number is mentioned, this shall be understood as internal ISUP calling party number.
- Where ISUP Generic Number (additional calling party number) is mentioned, this shall be understood as internal ISUP Generic Number (additional calling party number).

NOTE: Only the userinfo component of the received SIP URI is used by mapping procedures according to 3GPP TS 29.163 [13] while the received host part is ignored and a new value is generated by the MGCF.

When sending an initial INVITE request towards the IMS network the MGCF shall perform the following actions to generate the Request-URI and the To header field:

- Create an internal ISUP called party number from the received Request URI according to 3GPP TS 29.163 [13]. When Number Portability is supported the MGCF shall follow the procedures specified in subclause 7.2.3.1.2A of 3GPP TS 29.163 [13]. Otherwise the internal ISUP called party number is generated as specified in subclause 7.2.3.1.2.1 of 3GPP TS 29.163 [13].
- Generate the new Request-URI and the new To header field from the internal ISUP called party number according to 3GPP TS 29.163 [13]. When Number Portability is supported the MGCF shall follow the procedures specified in subclause 7.2.3.2.2A of 3GPP TS 29.163 [13]. Otherwise the Request-URI and the To header field are generated as specified in subclause 7.2.3.2.2.1 of 3GPP TS 29.163 [13].

When sending an initial INVITE request towards the IMS network the MGCF shall perform the following actions to generate the P-Asserted-Identity and the From header fields:

- create an internal ISUP calling party number and an internal Generic Number (additional calling party number) as specified in subclauses 7.2.3.1.2.6 and 7.2.3.1.2.7 of 3GPP TS 29.163 [13]; and
- generate the new P-Asserted-Identity and the From header from the internal ISUP calling party number and the internal Generic Number (additional calling party number) as specified in subclause 7.2.3.2.2.3 of 3GPP TS 29.163 [13].

When sending the initial SIP INVITE request to the IMS network and if the Hop Counter procedure is supported in the SIP-I based circuit switched core network (national option), then the MGCF shall either generate the Max-Forwards value from the received ISUP Hop Counter parameter by applying the rules in subclause 7.2.3.2.2.4 of 3GPP TS 29.163 [13] and decrementing the resulting value by one or forward the received Max-Forwards value decremented by one.

Otherwise if the MGCF forwards SIP request, it shall either set the Max-Forwards header to a default value or forward the received Max-Forwards value decremented by one.

When receiving any SIP request with a Max-Forwards field value of zero, and if request shall be propagated to the other side, the MGCF shall reject the request with a 483 (Too Many Hops) SIP final response, in accordance with IETF RFC 3261 [20].

7.4 DMTF Signalling Interworking applicable for all Calls between an IP Multimedia CN Subsystem and a SIP-I based circuit-switched core network

The procedures in subclause 4.4 are applicable with modifications described in the present subclause.

Where the external SIP-I network is mentioned in the procedures in subclause 4.4, this shall be understood as IP Multimedia (IM) Core Network (CN) Subsystem. Where an "IWU" is mentioned in those procedures, this shall be understood as MGCF.

The IMS need not include the PCM codec in SDP offers and answers it sends.

However, it is assumed that the RTP Telephony Event will always be included in SDP offers and answers from the IMS.

If an IWU receives an SDP offer from a preceding 3GPP SIP-I node without the RTP Telephony Event (only permitted if only default PCM codec offered) then it shall include the RTP Telephony Event in the subsequent offer to the IMS.

Procedures in subclause 4.4 related to receiving SDP offers or answers from the external network without the RTP Telephony Event do not apply for the interworking towards the IMS.

7.5 User Plane Interworking

7.5.1 General

This subclause describes user plane issues including interworking of DTMF.

Figure 7.5.1.1 shows the user plane protocol stacks within the IP Multimedia Subsystem and the 3GPP SIP-I based circuit switched core network.

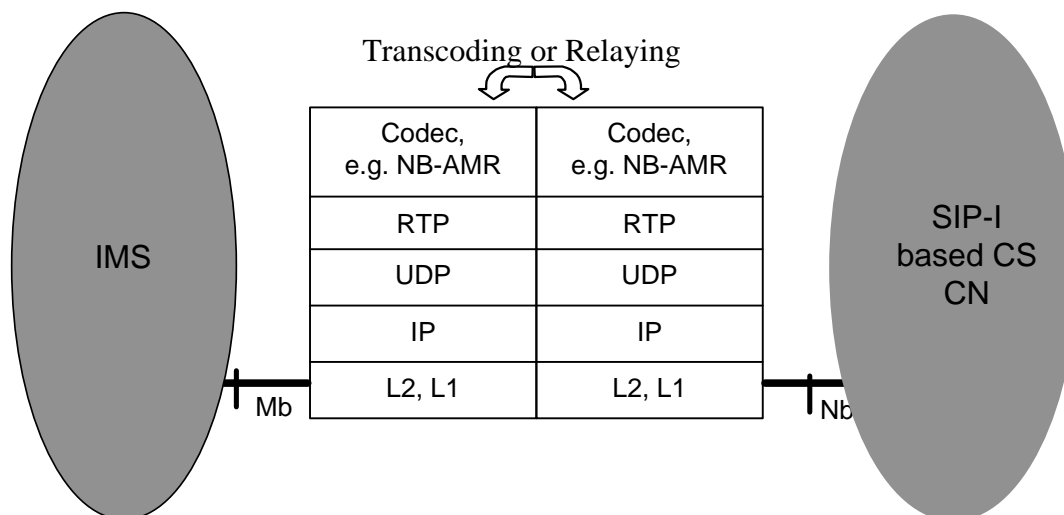

Figure 7.5.1.1: user plane interworking

If the same speech codec is used on both sides, no speech transcoding is required.

7.5.2 DTMF Interworking

The procedures in subclause 4.5.2 are applicable, however where the external SIP-I network is mentioned in those procedures, this shall be understood as IP Multimedia (IM) Core Network (CN) Subsystem. Where an "IWU" is mentioned in those procedures, this shall be understood as MGCF.

7.6 Example Call flows

7.6.1 General

In this subclause call flows are shown as examples to demonstrate the signalling interworking of the MGCF. Within the message sequence charts some contents of the messages are shown in order to visualise some of the important interworking aspects, which were described in previous subclauses of this document. It is to be noted that the intention is neither to show the complete content of the SIP messages nor to use the exact syntax of SIP and SDP messages as it is defined in the respective RFCs. It is also not the intention to show all alternative options that are possible for a certain call flow.

7.6.2 Incoming Call flows

The first call flow shows the signalling for a successful basic call establishment and the later call release. The second call flow depicts a failed call setup.

7.6.2.1 Successful Call Establishment and Call Release

Figure 7.6.2.1.1 shows the first part of the incoming call signalling until the called party is alerted and the MGCF is waiting for an answer message.

Before the received SIP INVITE request is forwarded to SIP-I based circuit switched core network the MGCF removes the PSTN XML body (after content mapped into SIP-I message), replaces the received codec list by a 3GPP structured codec list, and encapsulates the ISUP IAM message, which the MGCF mapped from the received SIP INVITE request.

The incoming side RTP bearer termination is not yet successfully reserved and configured and therefore local preconditions are not met. Thus the MGCF initiates precondition signalling when sending the INVITE request to the succeeding SIP-I based circuit-switched network.

The MGCF and the succeeding node perform codec negotiation according to 3GPP rules as specified in 3GPP TS 23.153 [5]. The MGCF answers to the preceding IMS node with a single selected codec. If possible, the selected codec is the same as received from the 3GPP node to avoid transcoding at the network border.

With the 183 Progress the MGCF authorizes the preceding node to use early media. Therefore, it is not necessary to include the P-Early-Media header in the 180 Ringing response.

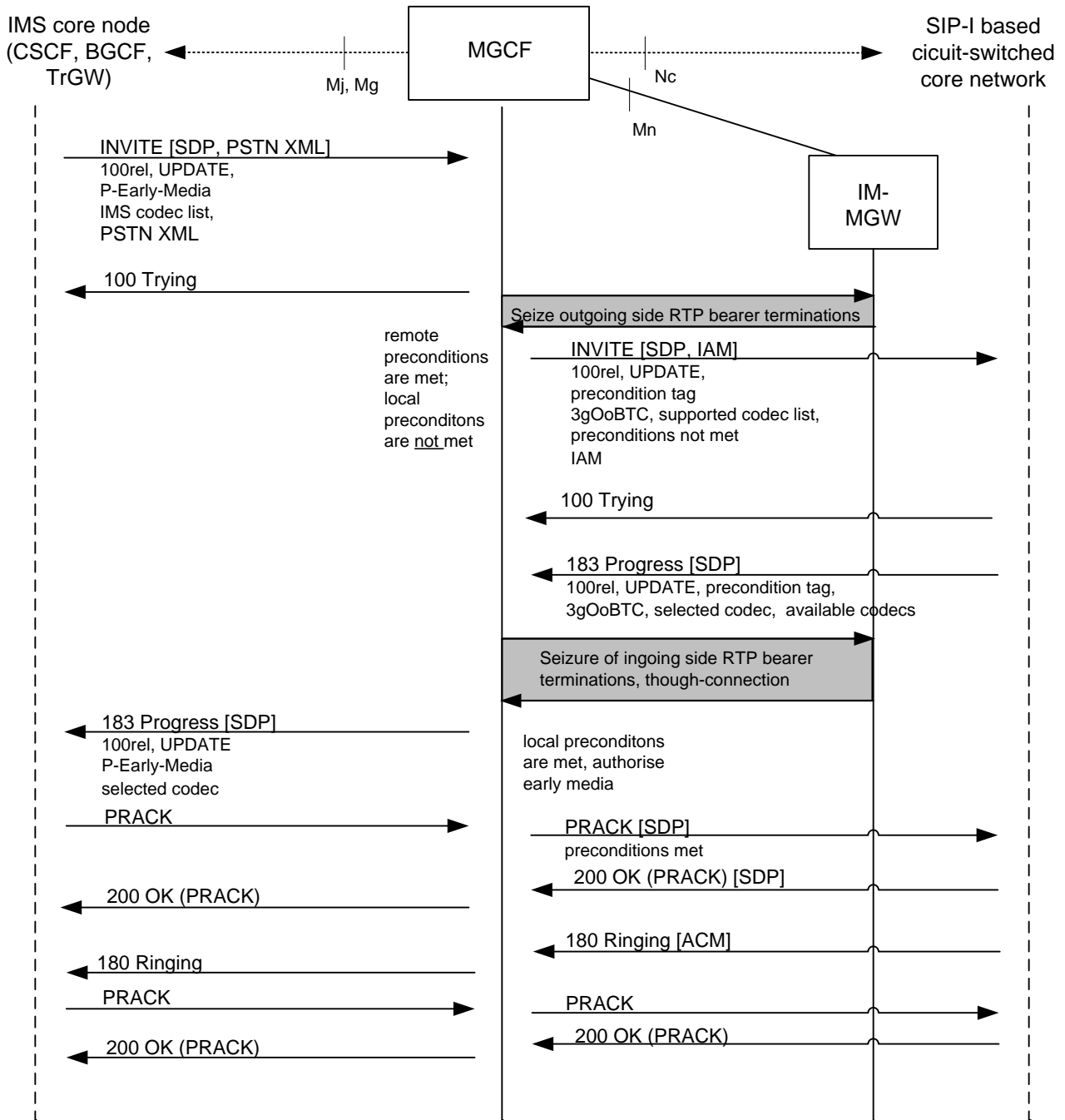
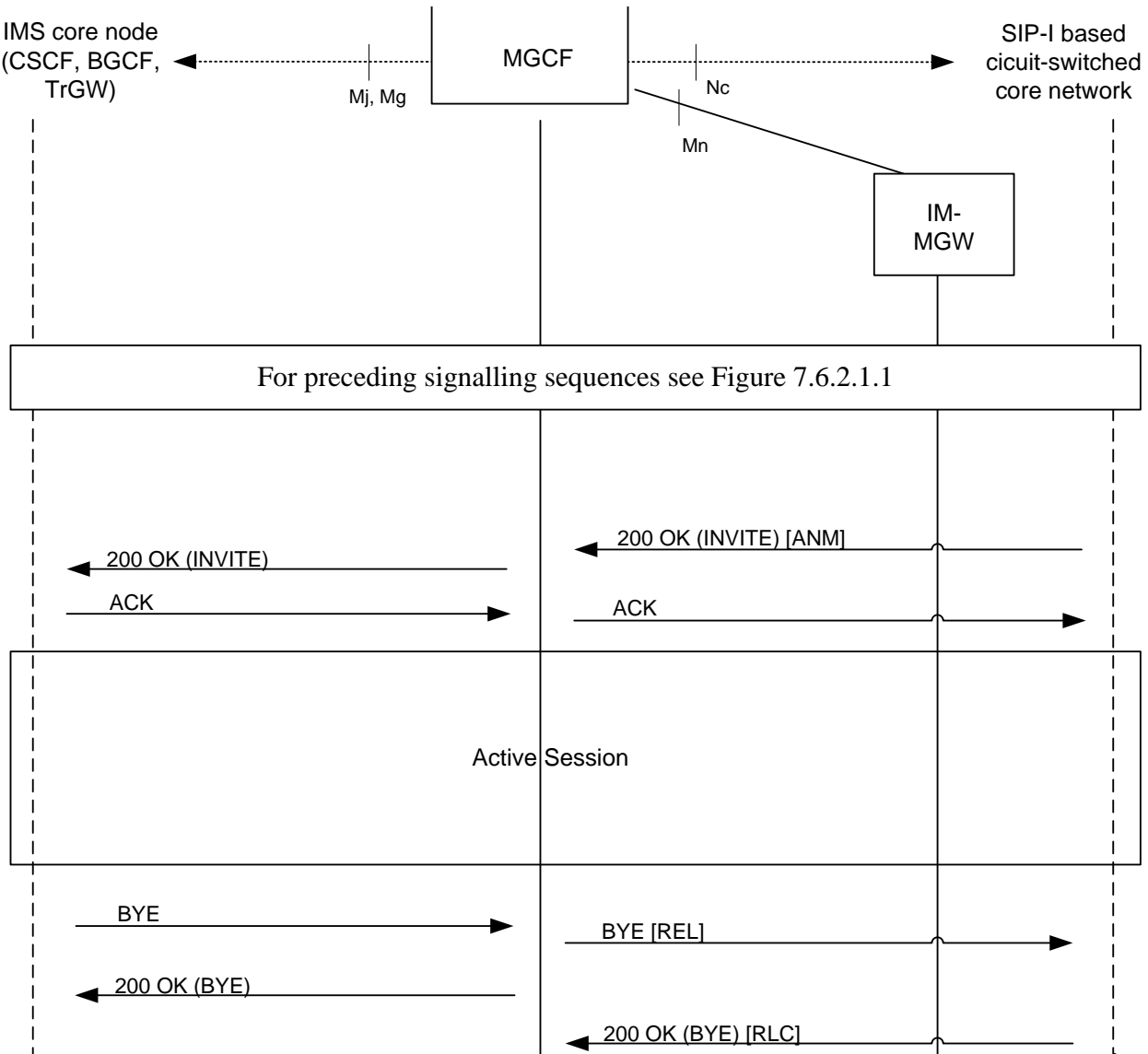

Figure 7.6.2.1.1: Incoming Call (message sequence chart), Called Party alerted

Figure 7.6.2.1.2 shows how the call setup is finalised and how the call is later released from the IMS side.



**Figure 7.6.2.1.2: Incoming Call (message sequence chart),
Continuation of figure 7.6.2.1.1**

7.6.2.2 Autonomous Release at MGCF

In this example, the MGCF is waiting for an answer from the called subscriber, i.e. the final response to the SIP INVITE request. Figure 7.6.2.2.1 shows the signalling when the waiting timer expires. The MGCF initiates call clearing towards the succeeding SIP-I based circuit-switched network by sending an ISUP REL message included in a SIP BYE request. It also sends a final response for the SIP INVITE request towards the preceding IMS node indicating the error that happened.

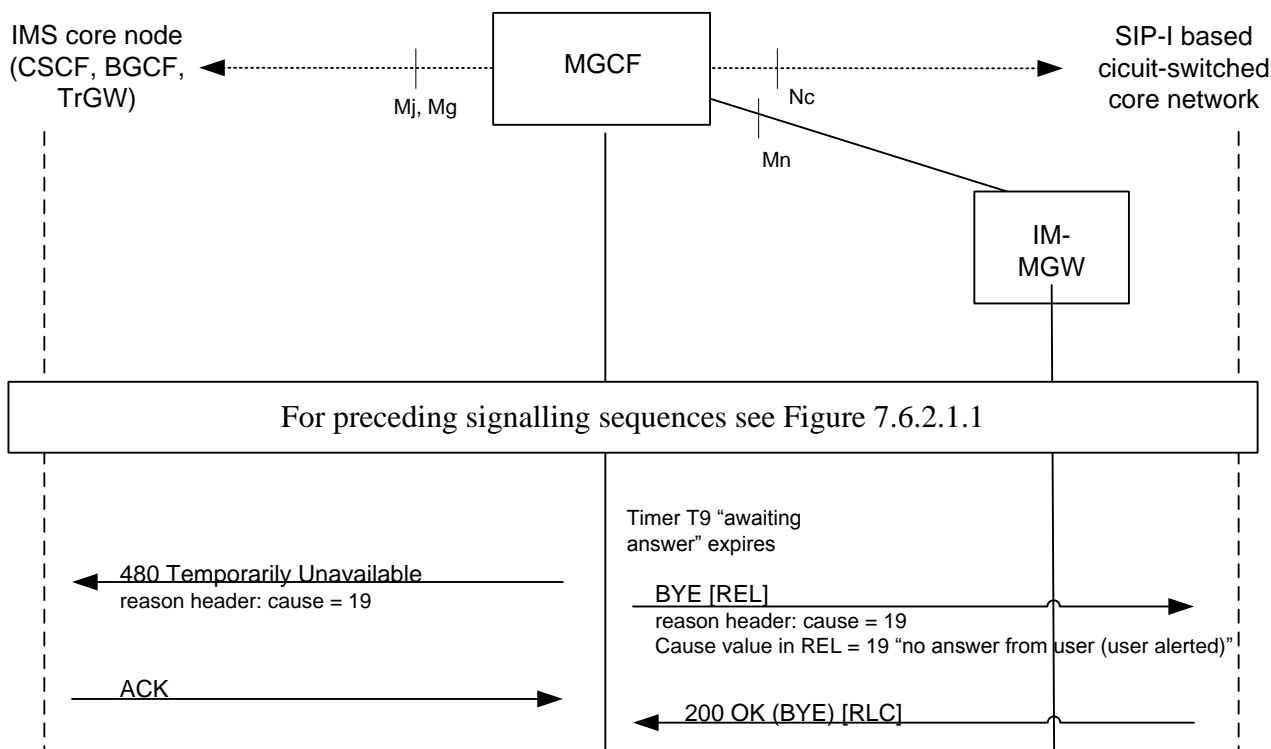

Figure 7.6.2.2.1: Incoming Call Failure (message sequence chart), called subscriber does not answer

7.6.3 Outgoing Call flows

The first two call flows show the signalling for a successful basic call establishment. The third call flow shows interworking when the call is forked within the IMS.

7.6.3.1 Outgoing Call, Sending of INVITE is deferred

Figure 7.6.3.1.1 shows an outgoing call where the preconditions are not met when the MGCF receives the initial SIP INVITE. The MGCF defers sending of INVITE until preconditions are met. The MGCF selects a codec and sends back 183 Progress. When the MGCF receives the SIP UPDATE request remote preconditions are met.

When the MGCF sends the SIP INVITE request to the next IMS node, it does not request the support for preconditions. The selected codec is inserted as the first one within the list of offered codecs. Shown, as a network option, is the inclusion of the PSTN XML body, which is mapped from the previously received ISUP information. The MGCF offers the support for early media which is confirmed by the IMS node in the 183 progress. In this example, the answer does not authorise early media because in-band tones or announcements are not provided.

When a 180 Ringing provisional response is received from the succeeding IMS the MGCF orders the IM-MGW to start sending the ringing tone before it propagates the 180 Ringing, which includes the ISUP ACM, to the preceding SIP-I based circuit-switched core network.

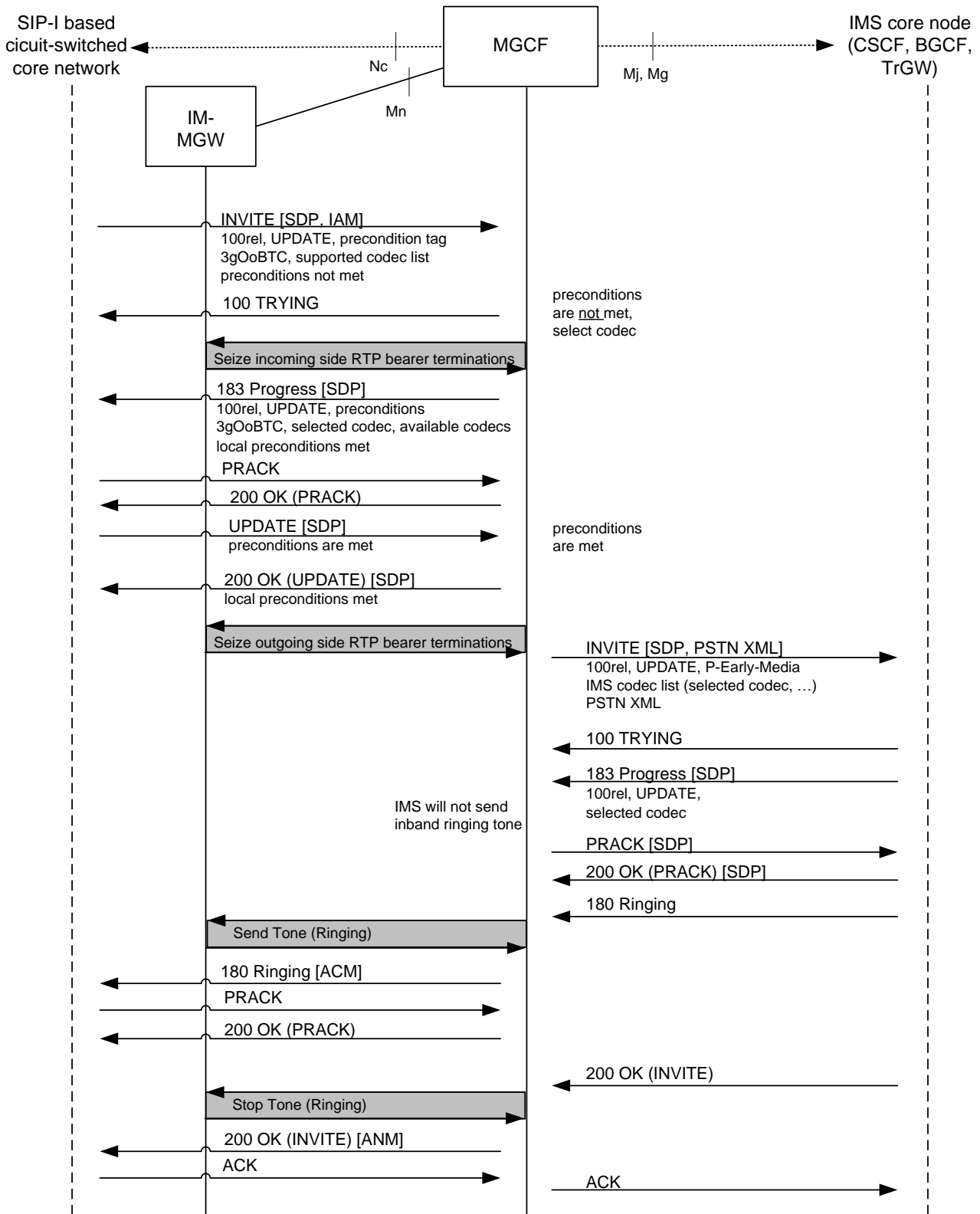

Figure 7.6.3.1.1: Outgoing Call, sending of INVITE is deferred until preconditions are met

7.6.3.2 Outgoing Call, Sending of INVITE is not deferred

Figure 7.6.3.2.1 shows an outgoing call where the preconditions are not met when the MGCF receives the initial SIP INVITE. When the MGCF sends the SIP INVITE request to the next IMS node before preconditions are fulfilled, it requests the support for preconditions.

Support for preconditions is confirmed from the IMS node. The MGCF receives more than one codec in the 183 Progress from the external node. Therefore the MGCF selects one of the received codecs and makes a second SDP offer to the external node in the SIP PRA CK request in order to lock the codec.

When the MGCF receives from the incoming side an UPDATE message indicating that preconditions are fulfilled, it propagates the UPDATE message towards the IMS.

When a 180 Ringing provisional response is received from the succeeding IMS the MGCF orders the IM-MGW to start sending the ringing tone before it propagates the 180 Ringing, which includes the ISUP ACM, to the preceding SIP-I based circuit-switched core network.

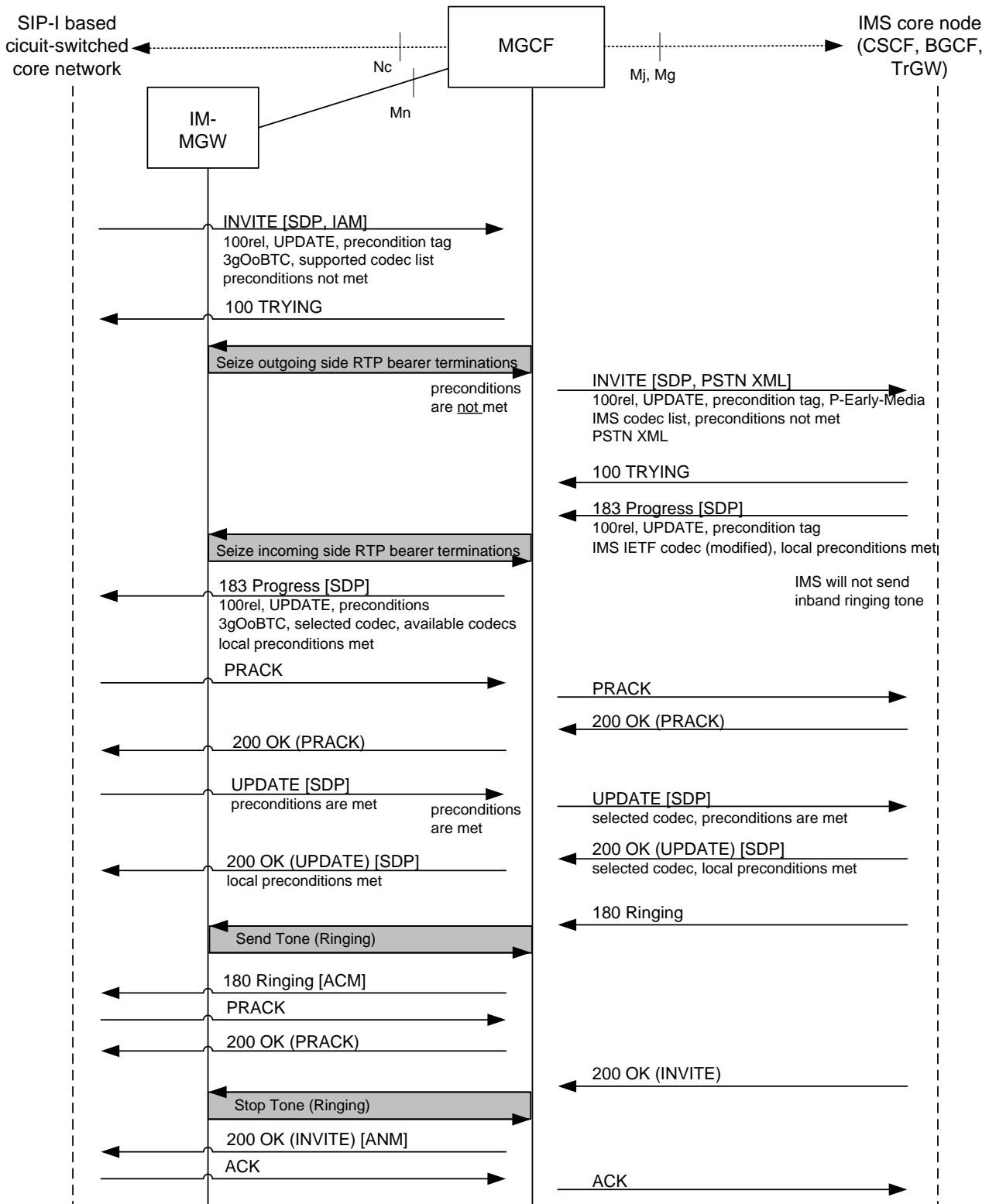

Figure 7.6.3.2.1: Outgoing Call, sending of INVITE is not deferred until preconditions are met

7.6.3.3 Interworking with forked SIP INVITE Requests

In this example, the SIP INVITE request is routed within the IMS to a forking proxy. Therefore the MGCF has to interwork with multiple early dialogues. This is shown in figures 7.6.3.3.1 and 7.6.3.3.2, where only those message contents are shown that are needed for the understanding of this call flow.

When receiving the first 183 Session Progress within dialogue A, the handling is done as in the previous call flow example (figure 7.6.3.2.1). Afterwards the MGCF receives another 183 Session Progress but within a second dialogue

B. In this example, the received codec list does not include the codec which is already selected for dialogue A. Therefore the MGCF can not directly send the selected codec to the succeeding IMS node within the second dialogue B.

When the SIP UPDATE request is received, which indicates that preconditions are met, the MGCF sends two SIP UPDATE requests to the succeeding IMS node to signal within both dialogues that preconditions are met.

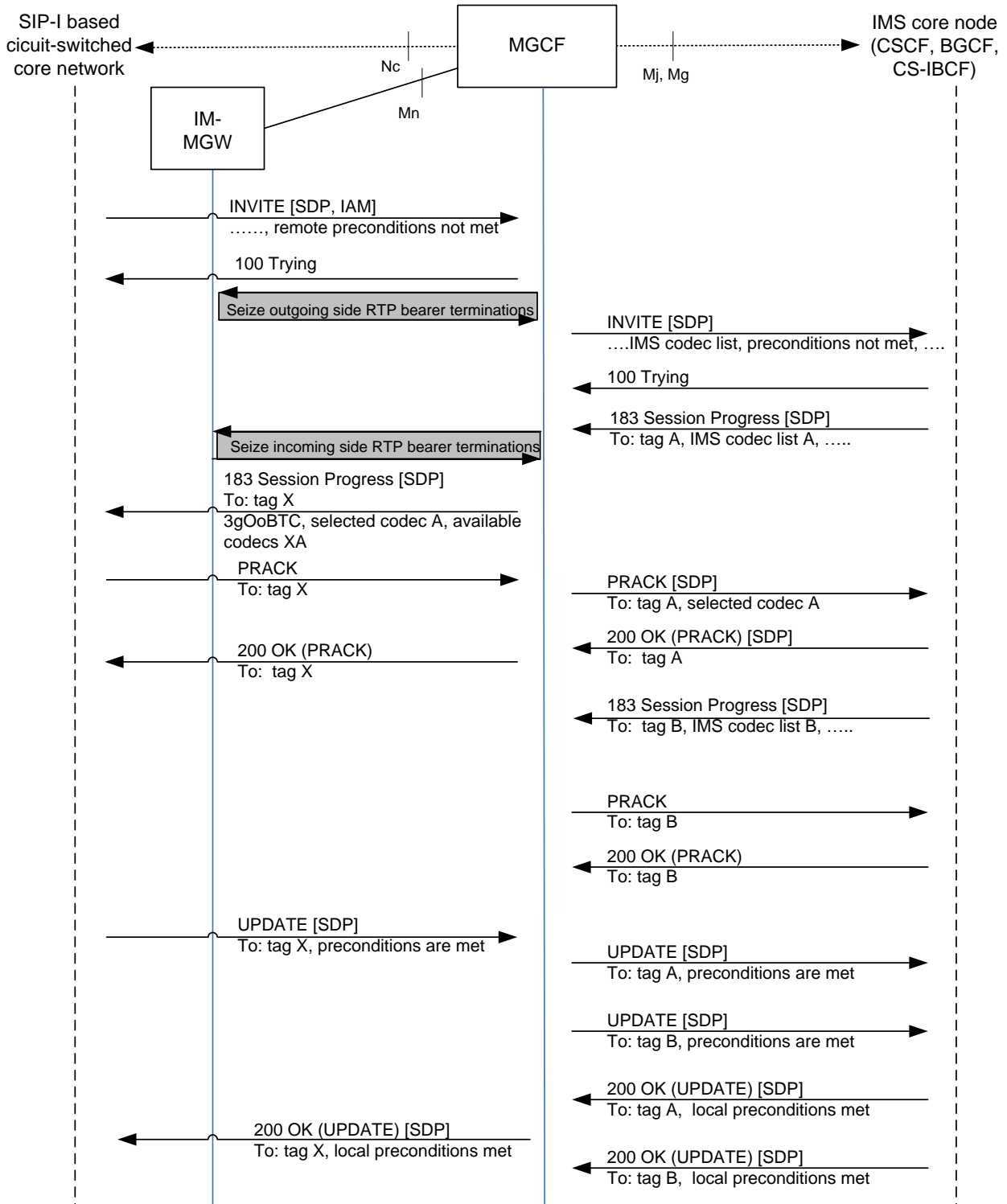

Figure 7.6.3.3.1: Outgoing Call, multiple early dialogues

Figure 7.6.3.3.2 shows that only the first 180 Ringing received from the IMS node is interworked with the SIP-I based circuit-switched core network.

Finally, the SIP INVITE request is answered with a 200 OK within dialogue B.

Any subsequent final response within dialogue A is acknowledged (with an ACK request) and immediately rejected by sending back a SIP BYE request.

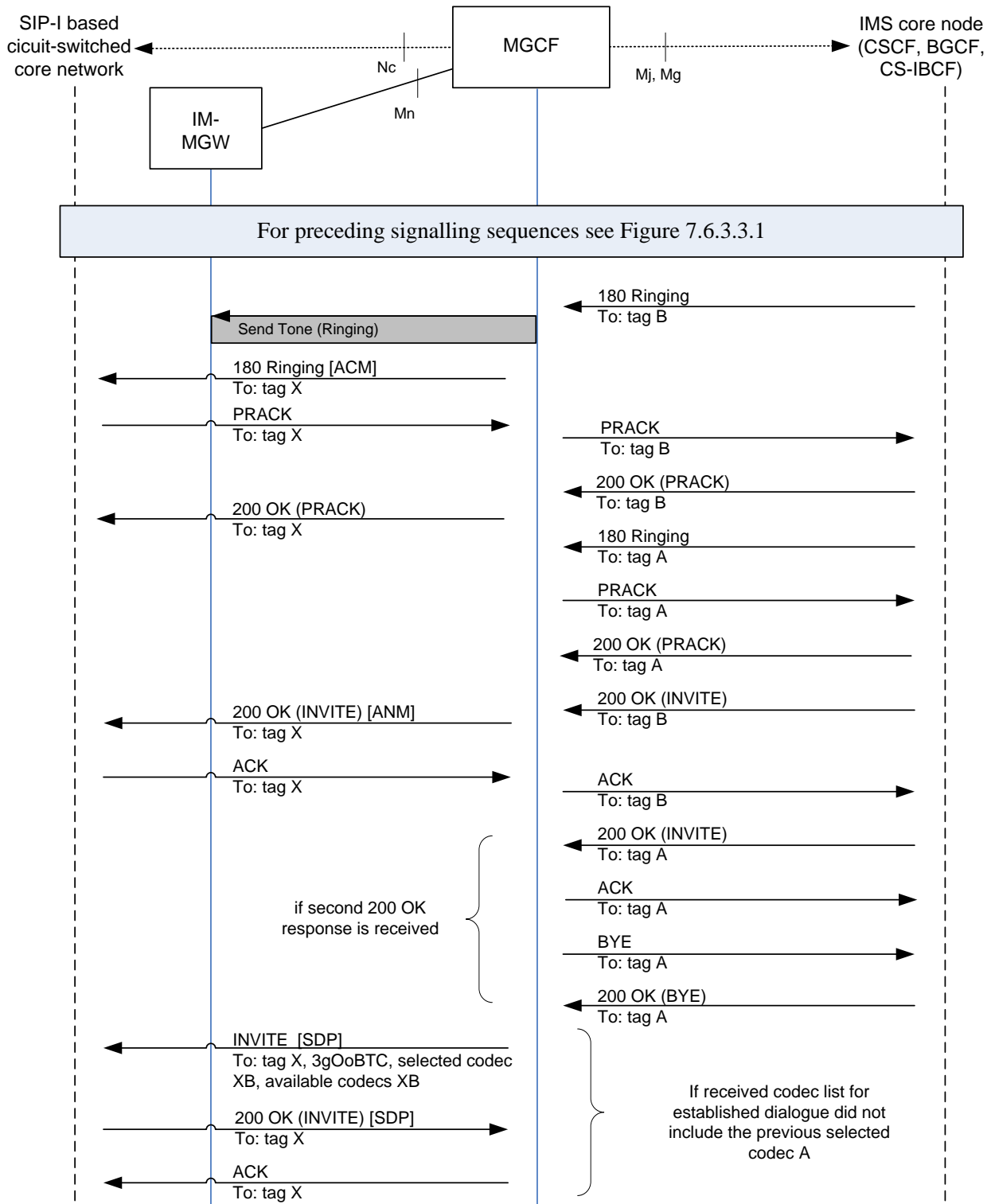

Figure 7.6.3.3.2: Outgoing Call, multiple early dialogues (continuation of figure 7.6.3.3.1)

7.7 CS CN Supplementary Services and IMS Supplementary Services

7.7.0 General

The following subclauses describe the MGCF behaviour when:

- Supplementary services are invoked within the SIP-I based circuit switched core network and
- Supplementary services are invoked within the IMS.

The support of these supplementary services is optional. If the supplementary services are supported, the procedures described within this subclause shall be applied.

Within the SIP-I based circuit switched core network:

- Service information is carried within encapsulated ISUP messages.
- The procedures specified for the ISUP side in 3GPP TS 29.163 [13] subclauses 7.4 and 7.5 shall be applied to the encapsulated ISUP.

7.7.1 Number Identification Services

7.7.1.1 CS CN Supplementary Service - Calling Line Identification Presentation/Restriction (CLIP/CLIR)

There is no additional interworking beyond subclauses 7.2 and 7.3 when the Calling Line Identification Presentation or a Calling Line Identification Restriction supplementary service is invoked within the SIP-I based circuit switched core network.

7.7.1.2 CS CN Supplementary Service - Connected Line Identification Presentation /Restriction (COLP/COLR)

When the Connected Line Identification Presentation or Connected Line Identification Restriction supplementary service is invoked within the SIP-I based circuit switched core network, the MGCF shall perform the mapping to the Terminating Identification Presentation / Restriction service as specified in 3GPP TS 29.163 [13] subclause 7.5.2.

7.7.1.3 IMS Supplementary Service - Originating Identification Presentation (OIP) and Originating Identification Restriction (OIR)

There is no additional interworking beyond subclauses 7.2 and 7.3, when the Originating Identification Presentation or Originating Identification Restriction supplementary service is invoked within the IMS network.

7.7.1.4 IMS Supplementary Service - Terminating Identification Presentation (TIP) and Terminating Identification Restriction (TIR)

When the Terminating Identification Presentation or Terminating Identification Restriction supplementary service is invoked within the IMS network, the MGCF shall perform the mapping to the Connected Line Identification Presentation / Restriction supplementary service as specified in 3GPP TS 29.163 [13] subclause 7.5.2.

7.7.1.5 CS CN Supplementary Service – Direct Dialling In

There is no additional interworking beyond subclauses 7.2 and 7.3, when the Direct Dialling In supplementary service is invoked within the SIP-I based circuit switched core network.

7.7.1.6 CS CN Supplementary Service – Malicious Call Identification

When the Malicious Call Identification supplementary service is invoked within the SIP-I based circuit switched core network the MGCF shall perform the mapping as specified in 3GPP TS 29.163 [13] subclause 7.5.9.

7.7.1.7 IMS Supplementary Service – Malicious Communication Identification (MCID)

When Malicious Communication Identification service is invoked within the IMS network, then as specified in 3GPP TS 29.163 [13] subclause 7.5.9.2, the interworking to the Malicious Call Identification supplementary service shall not be applied.

7.7.1.8 CS CN Supplementary Service – Subaddressing

When the Subaddressing supplementary service is invoked within the SIP-I based circuit switched core network, the procedures specified in 3GPP TS 29.163 [13] subclause 7.4.5 shall be applied.

7.7.2 Diversion Services

7.7.2.1 CS CN Supplementary Service - Call Forwarding Services (CFU, CFB, CFNRy, CFNRc)

When any of the call forwarding supplementary services (CFU, CFB, CFNRy, and CFNRc) is invoked within the SIP-I based circuit switched core network, the MGCF shall perform the mapping to the Communication Diversion service as specified in 3GPP TS 29.163 [13] subclauses 7.5.4.2.2 and 7.5.4.3.

7.7.2.2 CS CN Supplementary Service – Call Deflection (CD)

When the Call Deflection supplementary service is invoked within the SIP-I based circuit switched core network the MGCF shall perform the mapping to the Communication Diversion service as specified in 3GPP TS 29.163 [13] subclauses 7.5.4.2.2 and 7.5.4.3.

7.7.2.3 IMS Supplementary Service – Communication Diversion (CDIV)

When a Communication Diversion supplementary service is invoked within the IMS network, the MGCF shall perform the mapping to a Call Diversion supplementary service as specified in 3GPP TS 29.163 [13] subclauses 7.5.4.2.1 and 7.5.4.3.

7.7.3 Waiting Services

7.7.3.1 CS CN Supplementary Service – Call Waiting

When the Call Waiting supplementary service is invoked within the SIP-I based circuit switched core network, the MGCF shall perform the mapping to the Communication Waiting service as specified in 3GPP TS 29.163 [13] subclause 7.5.12.1.

7.7.3.2 IMS Supplementary Service – Communication Waiting (CW)

When the Communication Waiting supplementary service is invoked within the IMS network, the MGCF shall perform the mapping to the Call Waiting supplementary service as specified in 3GPP TS 29.163 [13] subclause 7.5.12.2.

7.7.4 Hold Services

7.7.4.1 CS CN Supplementary Service – Call Hold

There is no additional interworking beyond subclauses 7.2 and 7.3, when the Call Hold supplementary service is invoked within the SIP-I based circuit switched core network.

7.7.4.2 IMS Supplementary Service – Communication Hold (HOLD)

There is no additional interworking beyond subclauses 7.2 and 7.3, when the Communication Hold supplementary service is invoked within the IMS network.

NOTE: Call hold for IMS is specified in 3GPP TS 24.610 [26].

7.7.5 Multiparty Services

7.7.5.1 CS CN Supplementary Services – Conference Calling (CONF) and Three-Party (3PTY)

When the Conference Calling and Three-Party supplementary services are invoked within the SIP-I based circuit switched core network, the procedures specified in 3GPP TS 29.163 [13] subclause 7.4.14 shall be applied.

7.7.5.2 IMS Supplementary Service – Conference (CONF)

When the Conference supplementary service is invoked within the IMS network, the procedures specified in 3GPP TS 29.163 [13] subclause 7.5.6 shall be applied.

7.7.6 Closed User Group Service

7.7.6.1 CS CN Supplementary Service – Closed User Group (CUG)

When the Closed User Group supplementary service is invoked within the SIP-I based circuit switched core network, the procedures specified in 3GPP TS 29.163 [13] subclause 7.5.10.2 shall be applied.

7.7.6.2 IMS Supplementary Service - Closed User Group (CUG)

When the Closed User Group supplementary service is invoked within the IMS network, the procedures specified in 3GPP TS 29.163 [13] subclause 7.5.10.1 shall be applied.

7.7.7 Charging Services

7.7.7.1 CS CN Supplementary Service – Advice of Charge (AoC)

Editor's note: interworking for AoC is FFS.

7.7.7.2 IMS Supplementary Service – Advice of Charge (AOC)

Editor's note: interworking for AOC is FFS.

7.7.7.3 CS CN Supplementary Service – International Telecommunication Charge Card (ITCC)

When the International Telecommunication Charge Card supplementary service is invoked within the SIP-I based circuit switched core network no additional treatment is required by the MGCF.

7.7.7.4 CS CN Supplementary Service – Reverse Charging (REV)

When the Reverse Charging supplementary service is invoked within the SIP-I based circuit switched core network, the procedures specified in 3GPP TS 29.163 [13] subclause 7.4.17 shall be applied.

7.7.8 Barring Services

7.7.8.1 CS CN Supplementary Service - Barring of Outgoing Calls

There is no additional interworking beyond subclauses 7.2 and 7.3, when the Barring of Outgoing Call supplementary service is invoked within the SIP-I based circuit switched core network.

7.7.8.2 CS CN Supplementary Service - Barring of Incoming Calls

There is no additional interworking beyond subclauses 7.2 and 7.3, when the Barring of Incoming Calls supplementary service is invoked within the SIP-I based circuit switched core network.

7.7.8.3 CS CN Supplementary Service - Anonymous Call Rejection (ACR)

When the Anonymous Call Rejection supplementary service is invoked within the SIP-I based circuit switched core network, the procedures specified in 3GPP TS 29.163 [13] subclause 7.4.23.1 shall be applied.

7.7.8.4 IMS Supplementary Service – Communication Barring (CB)

Editor's note: interworking of Communication Barring is FFS.

7.7.8.5 IMS Supplementary Service – Anonymous Communication Rejection (ACR)

When the Anonymous Communication Rejection supplementary service is invoked within the IMS network, the procedures specified in 3GPP TS 29.163 [13] subclause 7.4.23.2 shall be followed with the following modifications at the SIP-I on Nc side:

- The response code 433 (Anonymity Disallowed) defined by IETF RFC 5079 [36] is supported on SIP-I on Nc.

7.7.9 Transfer Services

7.7.9.1 CS CN Supplementary Service – Explicit Call Transfer (ECT)

When the Explicit Call Transfer supplementary service is invoked within the SIP-I based circuit switched core network and the MGCF receives from the SIP-I based circuit-switched core network an INFO message with encapsulated ISUP FAC for the notification of ECT invocation, then the MGCF shall:

- map the FAC into a SIP re-INVITE request or SIP UPDATE request according to 3GPP TS 29.163 [13] if the call is in active state (after answer).
- map the FAC into a SIP UPDATE request according to 3GPP TS 29.163 [13] if the call is in active state (before answer).

7.7.9.2 IMS Supplementary Service – Explicit CommunicationTransfer (ECT)

When the Explicit CommunicationTransfer supplementary service is invoked within the IMS network and if the transferee is another IMS terminal and the transfer target is a CS terminal, then the MGCF will receive a SIP INVITE request. No special interworking is required at the MGCF.

NOTE: The protocol for ECT within IMS is specified in 3GPP TS 24.629 [25]. The IMS terminal, which invokes the ECT service, sends a SIP REFER request to the transferee. The transferee sends a SIP INVITE request to the transfer target.

7.7.10 Call Completion Services

7.7.10.1 CS CN Supplementary Service – Completion of Calls to Busy Subscriber (CCBS)

When the Completion of Calls to Busy Subscriber supplementary service is invoked within the SIP-I based circuit switched core network, the procedures specified in 3GPP TS 29.163 [13] subclause 7.4.11 shall be applied.

7.7.10.2 CS CN Supplementary Service – Completion of Calls on No Reply (CCNR)

When the Completion of Calls on No Reply supplementary service is invoked within the SIP-I based circuit switched core network, the procedures specified in 3GPP TS 29.163 [13] subclause 7.4.12 shall be applied.

7.7.10.3 IMS Supplementary Service – Completion of Communications to Busy Subscriber (CCBS) and Completion of Communication on No Reply (CCNR)

When the Completion of Communications to Busy Subscriber or Completion of Communication on No Reply supplementary service is invoked within the IMS network, the procedures specified in 3GPP TS 29.163 [13] subclause 7.5.11.1 shall be applied.

7.7.11 Miscellaneous Services

7.7.11.1 CS CN Supplementary Service - Multi-Level Precedence and Pre-emption (MLPP)

When the Multi-Level Precedence and Pre-emption (MLPP) supplementary service is invoked within the SIP-I based circuit switched core network the procedures specified in 3GPP TS 29.163 [13] subclause 7.4.17 shall be applied.

7.7.11.2 CS CN Supplementary Service - Multiple Subscriber Profile (MSP)

There is no additional interworking beyond subclauses 7.2 and 7.3 when a Multiple Subscriber Profile supplementary service is invoked within the SIP-I based circuit switched core network.

7.7.11.3 CS CN Supplementary Service - Multicall

There is no additional interworking beyond subclauses 7.2 and 7.3 when the Multicall supplementary service is invoked within the SIP-I based circuit switched core network.

7.7.11.4 CS CN Supplementary Service - Calling Name Presentation

There is no additional interworking beyond subclauses 7.2 and 7.3, when the Calling Name Presentation supplementary service is invoked within the SIP-I based circuit switched core network.

7.7.11.5 CS CN Supplementary Service – User-to-User Signalling (UUS)

Editor's note: interworking for User-to-User Signalling is FFS.

7.7.11.6 IMS Supplementary Service – Message Waiting Indication (MWI)

Editor's note: interworking for Message Waiting Indication is FFS.

7.7.11.7 CS CN Supplementary Service - Global Virtual Network Service (GVNS)

When the Global Virtual Network Service supplementary service is invoked within the SIP-I based circuit switched core network the procedures specified in 3GPP TS 29.163 [13] subclause 7.4.18 shall be applied.

7.7.11.8 CS CN Supplementary Service - Terminal Portability (TP)

When the Terminal Portability supplementary service is invoked within the SIP-I based circuit switched core network, the procedures specified in 3GPP TS 29.163 [13] subclause 7.4.13 shall be applied.

7.7.12 Customized Alerting Tones Services

7.7.12.1 CS CN Supplementary Service - Customized Alerting Tones (CAT)

When the Customized Alerting Tones supplementary service is invoked within the SIP-I based circuit switched core network, the MGCF shall perform the mapping as specified in 3GPP TS 29.163 [13] subclause 7.4.24.

7.7.12.2 IMS Supplementary Service - Customized Alerting Tones (CAT) for early session model

When the Customized Alerting Tones supplementary service is invoked within the IMS network using early session model, the MGCF shall perform the mapping for normal session SDP negotiation and early session SDP negotiation as specified in 3GPP TS 29.163 [13] subclause 7.5.13.2.

7.7.12.3 IMS Supplementary Service - Customized Alerting Tones (CAT) for forking model

When the Customized Alerting Tones supplementary service is invoked within the IMS network using forking model, the MGCF shall perform the mapping as specified in 3GPP TS 29.163 [13] subclause 7.5.13.3.

7.7.12.4 IMS Supplementary Service - Customized Alerting Tones (CAT) for gateway model

When the Customized Alerting Tones supplementary service is invoked within the IMS network using gateway model, the MGCF shall perform the mapping as specified in 3GPP TS 29.163 [13] subclause 7.5.13.4.

7.8 MGCF – IM-MGW Interaction

7.8.1 General

The present subclause describes signalling procedures that are applicable at the Mn interface when the MGCF and attached IM-MGW interwork between an IM CN Subsystem and a SIP-I based circuit-switched core network.

The MGCF shall interact with the IM-MGW across the Mn reference point. The signalling interface across the Mn reference point is defined in accordance with ITU-T Recommendation H.248.1 [53] and shall conform to 3GPP specific extensions as detailed in 3GPP TS 29.332 [54].

7.8.2 Call related Procedures for Terminations towards the IM CN Subsystem

Subclause 9.3.1 in 3GPP TS 29.163 [13] shall apply.

7.8.3 Call related Procedures for Terminations towards SIP-I based Circuit-switched Core Network

Those procedures defined in 3GPP TS 23.205 [9] that are listed in table 7.8.3.1 shall apply.

Table 7.8.3.1: Call related Procedures defined in 3GPP TS 23.205 [9] that are applicable at terminations towards SIP-I based circuit-switched core network

Procedure defined in 3GPP TS 23.205 [9]	Remarks
Change Flow Direction	NOTE 1 in that subclause is replaced by: NOTE 1: This procedure may be combined with the "Reserve RTP Connection Point" procedure, the "Configure RTP Connection Point" procedure, or the "Reserve and Configure RTP Connection Point" procedure.
Change Through-Connection	The NOTE in that subclause is replaced by: NOTE 2: This procedure may be combined with the "Reserve RTP Connection Point" procedure, the "Configure RTP Connection Point" procedure, or the "Reserve and Configure RTP Connection Point" procedure.
Bearer Released	
Release Termination	
Send Tone	
Stop Tone	
Play Announcement	Optional
Stop Announcement	Optional
Announcement Completed	Optional
Tone Completed	
Activate Voice Processing Function	Optional
Termination heartbeat indication	
Reserve RTP Connection Point	
Configure RTP Connection Point	
Reserve and Configure RTP Connection Point	

7.8.4 Non-call related procedures

Subclause 9.3.4 in 3GPP TS 29.163 [13] shall apply.

Annex A (normative): Interconnecting functionalities in SIP-I based CS domain

A.1 General

This annex describes a collection of functions that can be performed on interconnection boundaries between two SIP-I based 3GPP CS networks or between a SIP-I based CS network and other SIP-I based external network, based on operator configuration.

In subclauses A.2 and A.3 Stage 2 requirements and border control architecture are described.

A.2 Stage 2 Requirements

Based on operator preference, border control functions may be applied between two SIP-I based 3GPP CS domains or between a SIP-I based 3GPP CS domain and other SIP-I based external network. These functions, provided by the CS-IBCF, are:

- Controlling transport plane functions;
- Supporting functions to allow establishing communication between disparate address realms' SIP-I applications;

- Providing network configuration hiding to restrict the following information from being passed outside of an operator's network: exact number of MSC servers, capacity and topology of the network, naming and addressing of the network nodes;
- Screening SIP signalling information based on source/destination and operator policy (e.g. remove information that is of local significance to an operator);
- Selecting the appropriate signalling interconnections (e.g. domain based routing). The IP interconnection between core networks may be supported either by direct connection or by using an intermediate carrier;
- Supporting network resources allocation taking into consideration the codec negotiation performed by (G)MSCs across one or multiple interconnects, remaining transparent to the SDP negotiation.

In case border control concepts are to be applied in a SIP-I based CS network, the CS-IBCF acts as an entry point for this network, and also acts as an exit point for this network.

On the media plane the following functions shall be supported by the CS-TrGW:

- Gate Management:
 - Opening/closing of gates;
 - Remote source address filtering;
 - Remote source port filtering;
- QoS packet marking (differentiated services);
- NA(P)T and IP Version Interworking;
- Bandwidth policing;
- Hanging termination detection;
- IP Realm Indication.

Additionally, the following functions may be supported by the CS-TrGW:

- IP Realm Availability.

A.3 Border Control architecture

Figure A.3.1 presents a high-level architecture diagram showing how CS-IBCF and CS-TrGW logical functions fit into the SIP-I based CS domain.

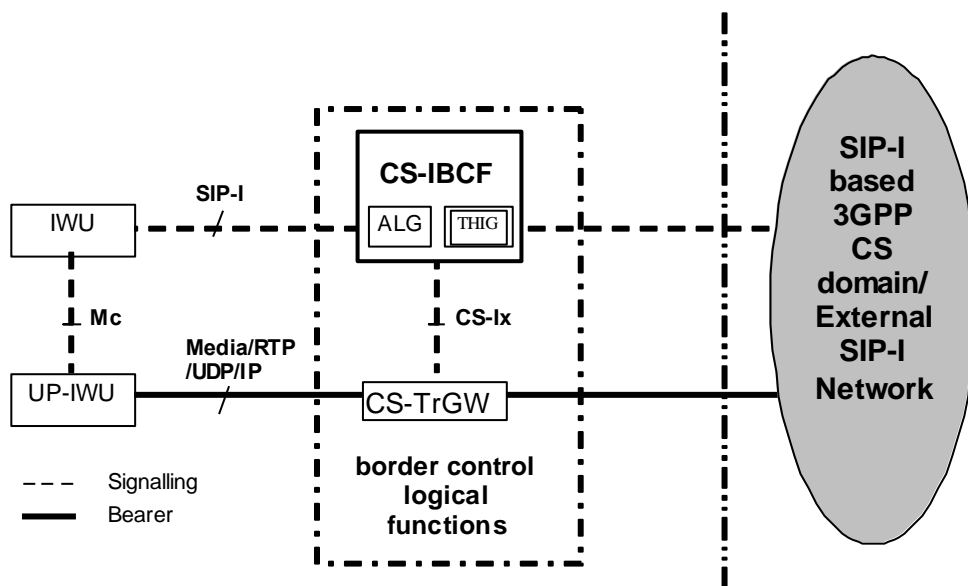

Figure A.3.1: CS-IBCF and CS-TrGW in SIP-I based CS domain

The CS-IBCF, which provides border control functions, shall be transparent to the call control application of the adjacent 3GPP SIP-I nodes. That is, outgoing SIP-I messages from a 3GPP MSC-IWU shall assume that it is signalling to an external network. The CS-IBCF shall not perform SIP-I profile interworking functions that are defined by the main text of this specification. The CS-IBCF is a logical function that either is co-located with IWU in a single physical (G)MSC-S node, or is within a separate physical node, e.g. when co-locating with IMS-IBCF.

The Nb reference point allows CS-MGWs to communicate with a CS-TrGW in order to provide border control functions. The CS-TrGW is a logical function that may reside in the UP-IWU. The CS-TrGW, which provides border control functions, shall be transparent to adjacent 3GPP MGWs. The CS-TrGW shall not perform any SIP-I user plane interworking functions that are defined by the main text of this specification. The CS-TrGW is a logical function that can be co-located with UP-IWU in a single physical CS-MGW node, but can also be in a separate physical node, e.g. when co-locating with IMS-TrGW.

If the logical functions are co-located with (G)MSC and CS-MGW then the Mc profile as defined by 3GPP TS 29.232 [55] shall provide the required functionality (described in subclause A.8). If CS-IBCF is physically separated then the CS-IBCF control function is connected to the CS-TrGW via the CS-Ix reference point (described in subclause A.7), which is realised by the Ix profile as defined by 3GPP TS 29.238 [29].

A.4 Void

A.5 Procedures at the CS-IBCF

A.5.1 General

Border control functions may be applied between two SIP-I based CS domains subsystems or between an SIP-I based CS domains and other SIP-I based networks based on operator preference. The CS-IBCF may act both as an entry point and as an exit point for a network. If it processes a SIP request received from other network it functions as an entry point (see subclause A.5.3) and it acts as an exit point whenever it processes a SIP request sent to other network (see subclause A.5.2).

Depending on its role, the functions of the CS-IBCF include:

- network configuration hiding (described in subclauses A.5.2.4 and A.5.3.4);
- application level gateway (in subclauses A.5.2.5 and A.5.3.5);
- screening of SIP signalling (in subclauses A.5.2.6 and A.5.3.6);

- charging (in subclauses A.5.2.7 and A.5.3.7).

NOTE: The functions performed by the CS-IBCF are configured by the operator, and they are network specific.

A.5.2 CS-IBCF as an exit point

A.5.2.1 Initial requests

Upon receipt of any request, the CS-IBCF shall:

- 1) if the request is an INVITE request, respond with a 100 (Trying) provisional response;
- 2) if the request is an INVITE request and the CS-IBCF is configured to perform application level gateway and/or transport plane control functionalities, save the Contact, CSeq, From and Record-Route header field values received in the request such that the CS-IBCF is able to release the session if needed;
- 3) if network topology hiding is required, apply the procedures as described in subclause A.5.2.4;
- 4) if screening of SIP signalling is required, apply the procedures as described in subclause A.5.2.6;
- 5) select an entry point of the destination network and forward the request to that entry point;

NOTE: The list of the entry points can be either obtained as specified in IETF RFC 3263 [30] or provisioned in the CS-IBCF. The entry point can be a CS-IBCF or an (G)MSC server.

When the CS-IBCF receives an INVITE request, the CS-IBCF may require the periodic refreshment of the session to avoid hung states in the CS-IBCF. If the CS-IBCF requires the session to be refreshed, the CS-IBCF shall apply the procedures described in IETF RFC 4028 [31] clause 8.

IETF RFC 3325 [32] provides for the existence and trust of an asserted identity within a trust domain. A CS-IBCF at the boundary of the trust domain will need to determine whether to remove the P-Asserted-Identity header according to IETF RFC 3325 [32] when SIP signalling crosses the boundary of the trust domain.

When the CS-IBCF receives a response to the initial request and network topology hiding is required, then the CS-IBCF shall apply the procedures as described in subclause A.5.2.4.

When the CS-IBCF receives a response to the initial request and screening of SIP signalling is applied, then the CS-IBCF shall apply the procedures as described in subclause A.5.2.6.

When the CS-IBCF receives a response to the initial INVITE request that establishes a dialogue, and the CS-IBCF is configured to perform application level gateway and/or transport plane control functions, the CS-IBCF shall save the Contact, To and Record-Route header field values received in the response such that the CS-IBCF is able to release the session if needed.

A.5.2.2 Subsequent requests

Upon receipt of any request, the CS-IBCF shall:

- 1) if the request is an INVITE request, respond with a 100 (Trying) provisional response;
- 2) if the request is a target refresh request and the CS-IBCF is configured to perform application level gateway and/or transport plane control functions, save the Contact and CSeq header field values received in the request such that the CS-IBCF is able to release the session if needed;
- 3) if the subsequent request is other than a target refresh request (including requests relating to an existing dialogue where the method is unknown) and the CS-IBCF is configured to perform application level gateway and/or transport plane control functionalities, save the Contact and CSeq header field values received in the request such that the CS-IBCF is able to release the session if needed;
- 4) if network topology hiding is required, apply the procedures as described in subclause A.5.2.4;
- 5) if screening of SIP signalling is required, apply the procedures as described in subclause A.5.2.6.

When the CS-IBCF receives a response to the subsequent request and network topology hiding is required, then the CS-IBCF shall apply the procedures as described in subclause A.5.2.4.

When the CS-IBCF receives a response to the subsequent request and screening of SIP signalling is required, then the CS-IBCF shall apply the procedures as described in subclause A.5.2.6.

A.5.2.3 CS-IBCF-initiated call release

If the CS-IBCF provides transport plane control functionality and receives an indication of a transport plane related error the CS-IBCF may:

- 1) if the CS-IBCF has already sent an initial INVITE request to the terminating side, apply SIP procedures detailed in IETF RFC 3261 [20] to terminate any corresponding SIP dialogue(s) or otherwise cancel the INVITE at the terminating side, making use of CANCEL and/or BYE request(s), based on information saved for the related dialogue; and
- 2) if the CS-IBCF has not yet sent out a final response for the initial INVITE request, send an appropriate failure response for the initial INVITE request to the originating side; and
- 3) if the CS-IBCF has already sent out a final response for the initial INVITE request, generate a BYE request for the originating side based on the information saved for the related dialogue.

NOTE 1: Transport plane related errors can be indicated from TrGW.

NOTE 2: Since the CS-IBCF does not handle the encapsulated ISUP, the BYE message(s) generated by the CS-IBCF will not contain any encapsulated ISUP REL message.

If the CS-IBCF is able to determine an appropriate Q.850 cause value, then this may be included in a Reason header in the BYE message(s).

A.5.2.4 THIG functionality in the CS-IBCF

A.5.2.4.1 General

The following procedures shall only be applied if network topology hiding is required by the network. The network requiring network topology hiding is called the hiding network.

NOTE 1: Requests and responses are handled independently; therefore, no state information is needed for that purpose within a CS-IBCF.

The CS-IBCF shall apply network topology hiding to all headers which reveal topology information, such as Via, Route, Record-Route, and Path. Therefore, the CS-IBCF shall:

- either act as a B2BUA, i.e. set above headers as defined for a SIP user agent client by IETF RFC 3261 [20],
- or as an option follow the procedures defined in A.5.2.4.2.

The CS-IBCF shall not screen SIP parameters for which there is a related ISUP parameter defined within ITU-T Recommendation Q.1912.5 [6].

NOTE 2: SIP-I screening is normally done by the MSC, where the encapsulated ISUP message and the SIP headers are consistently screened.

Upon receiving an incoming initial request for which network topology hiding has to be applied and which includes a Record-Route header, the CS-IBCF shall add its own routable SIP URI to the top of the Record-Route header.

A.5.2.4.2 Encryption for network topology hiding

Upon receiving a request/response, outgoing from the hiding network the CS-IBCF shall perform the encryption for network topology hiding purposes, i.e. the CS-IBCF shall:

- 1) use the whole header values which were added by one or more specific entity of the hiding network as input to encryption;

- 2) not change the order of the headers subject to encryption when performing encryption;
- 3) use for one encrypted string all received consecutive header entries subject to encryption, regardless if they appear in separate consecutive headers or if they are consecutive entries in a comma separated list in one header;
- 4) construct a hostname that is the encrypted string;
- 5) append a "tokenized-by" parameter and set it to the value of the encrypting network's name, after the constructed hostname;
- 6) form one valid entry for the specific header out of the resulting NAI, e.g. prepend "SIP/2.0/UDP" for Via headers or "sip:" for Path, Route and Record-Route headers;
- 7) if the CS-IBCF encrypted an entry in the Route header, then it also inserts its own URI before the topmost encrypted entry; and
- 8) if the CS-IBCF encrypted an entry in the Via header, then it also inserts its own URI before the topmost encrypted entry.

NOTE: Even if consecutive entries of the same network in a specific header are encrypted, they will result in only one encrypted header entry. For example:

```
Via: SIP/2.0/UDP ibcf1.home1.net;lr,
      SIP/2.0/UDP Token( SIP/2.0/UDP msc2.home1.net;lr,
                        SIP/2.0/UDP msc1.home1.net;lr);
                        tokenized-by=home1.net,
      SIP/2.0/UDP [5555::aaa:bbb:ccc:ddd]
```

A.5.2.5 ALG functionality in the CS-IBCF

The CS-IBCF shall only apply the following procedures if application level gateway functionality is required by the network.

The CS-IBCF acts as a B2BUA when it performs ALG functionality. The CS-IBCF, although acting as a UA, does not initiate any registration of its associated addresses. These are assumed to be known by peer-to-peer arrangements within the SIP-I based CS domain.

In case the initial INVITE request is received from own network, i.e. the CS-IBCF acts as an exit point, the CS-IBCF shall generate a new initial INVITE request and forward it to the entry point of the other network.

The internal function of the CS-IBCF as an ALG is equal to that one defined in 3GPP TS 29.162 [37].

A.5.2.6 Screening of SIP-I signalling

A.5.2.6.1 General

This section relates to the screening of the SIP headers and SDP of the SIP-I signalling for policing purposes. Inspection of ISUP MIME bodies is out of the scope of this specification.

The CS-IBCF shall act as a B2BUA when it performs screening of SIP signalling functionality. In this case the B2BUA behaviour of the CS-IBCF shall comply with the description given in subclause A.5.2.5 for the ALG functionality.

NOTE 1: Many headers are intended for end-to-end operation; removal of such headers will impact the intended end-to-end operation between nodes. Additionally security mechanisms covering SIP headers are not precluded; any such removal can prevent validation of all headers covered by the security mechanism.

NOTE 2: SIP-I screening is normally done by the MSC, where the encapsulated ISUP message and the SIP headers are consistently screened.

A.5.2.6.2 CS-IBCF procedures for SIP headers

If specified by local policy rules, the CS-IBCF may omit or modify any received SIP headers prior to forwarding SIP messages, with some exceptions.

NOTE 1: If the CS-IBCF modifies SIP information elements (SIP headers, SIP message bodies) other than as specified by SIP procedures (e.g., IETF RFC 3261 [20]) caution needs to be taken that SIP functionality (e.g., routing using Route, Record-Route and Via) is not impacted in a way that could create interoperability problems with networks that assume that this information is not modified.

NOTE 2: Where operator requirements can be achieved by configuration hiding, then these procedures can be used in preference to screening.

A.5.2.6.3 CS-IBCF procedures for SIP message bodies

If IP address translation (NA(P)T or IP version interworking) occurs on the user plane, the CS-IBCF shall modify SDP according to 3GPP TS 29.162 [37].

A.5.2.7 Void

A.5.3 CS-IBCF as an entry point

A.5.3.1 Initial requests

Upon receipt of any request, the CS-IBCF shall:

- 1) if the request is an INVITE request, then respond with a 100 (Trying) provisional response;
- 2) if the request is an INVITE request and the CS-IBCF is configured to perform application level gateway and/or transport plane control functions, save the Contact, Cseq, From and Record-Route header field values received in the request such that the CS-IBCF is able to release the session if needed;
- 3) if network topology hiding is required, then apply the procedures as described in subclause A.5.3.4;
- 4) if screening of SIP signalling is required, apply the procedures as described in subclause A.5.3.6;
- 5) If CS-IBCF receives an initial request for a dialogue or standalone transaction that contains a single Route header pointing to itself, and it is co-located with an (G)MSC server, or it has a preconfigured (G)MSC server to be contacted, then forward the request to that (G)MSC server. Otherwise select an (G)MSC server and forward the request to that (G)MSC server.

When the CS-IBCF receives an INVITE request, the CS-IBCF may require the periodic refreshment of the session to avoid hung states in the CS-IBCF. If the CS-IBCF requires the session to be refreshed, the CS-IBCF shall apply the procedures described in IETF RFC 4028 [31] clause 8.

When the CS-IBCF receives a response to an initial request (e.g. 183 or 2xx), the CS-IBCF shall:

- 1) if network topology hiding is required, apply the procedures as described in subclause A.5.3.4;
- 2) if screening of SIP signalling is applied, apply the procedures as described in subclause A.5.3.6; and
- 3) if the response establishes a dialogue, and the CS-IBCF is configured to perform application level gateway and/or transport plane control functions, the CS-IBCF shall save the Contact, To and Record-Route header field values received in the response such that the CS-IBCF is able to release the session if needed.

A.5.3.2 Subsequent requests

Upon receipt of any request, the CS-IBCF shall:

- 1) if the request is an INVITE request, then respond with a 100 (Trying) provisional response;
- 2) if the request is a target refresh request and the CS-IBCF is configured to perform application level gateway and/or transport plane control functions, save the Contact and Cseq header field values received in the request such that the CS-IBCF is able to release the session if needed;
- 3) if the subsequent request is other than a target refresh request (including requests relating to an existing dialogue where the method is unknown) and the CS-IBCF is configured to perform application level gateway and/or

transport plane control functions, save the Contact and Cseq header field values received in the request such that the CS-IBCF is able to release the session if needed;

- 4) if network topology hiding is required, then apply the procedures as described in subclause A.5.3.4;
- 5) if screening of SIP signalling is required, apply the procedures as described in subclause A.5.3.6.

When the CS-IBCF receives a response to the subsequent request and network topology hiding is required, then the CS-IBCF shall apply the procedures as described in subclause A.5.3.4.

When the CS-IBCF receives a response to the subsequent request and screening of SIP signalling is required, then the CS-IBCF shall apply the procedures as described in subclause A.5.3.6.

A.5.3.3 CS-IBCF-initiated call release

If the CS-IBCF provides transport plane control functionality and receives an indication of a transport plane related error the CS-IBCF may:

- 1) if the CS-IBCF has already sent an initial INVITE request to the terminating side, apply SIP procedures detailed in IETF RFC 3261 [20] to terminate any corresponding SIP dialogue(s) or otherwise cancel the INVITE at the terminating side, making use of CANCEL and/or BYE request(s), based on information saved for the related dialogue; and
- 2) if the CS-IBCF has not yet sent out a final response for the initial INVITE request, send an appropriate failure response for the initial INVITE request to the originating side; and
- 3) if the CS-IBCF has already sent out a final response for the initial INVITE request, generate a BYE request for the originating side based on the information saved for the related dialogue.

NOTE 1: Transport plane related errors can be indicated from e.g. TrGW .

NOTE 2: Since the CS-IBCF does not handle the encapsulated ISUP, the BYE message(s) generated by the CS-IBCF will not contain any encapsulated ISUP REL message.

If the CS-IBCF is able to determine an appropriate Q.850 cause value, then this may be included in a Reason header in the BYE message(s).

A.5.3.4 THIG functionality in the CS-IBCF

A.5.3.4.1 General

The following procedures shall only be applied if network topology hiding is required by the network. The network requiring network topology hiding is called the hiding network.

NOTE 1: Requests and responses are handled independently; therefore, no state information is needed for that purpose within a CS-IBCF.

The CS-IBCF shall apply network topology hiding to all headers which reveal topology information, such as Via, Route, Record-Route, and Path. Therefore, the CS-IBCF shall

- either act as a B2BUA, i.e. set above headers as defined for a SIP user agent client by IETF RFC 3261 [20],
- or as an option follow the procedures defined in A.5.3.4.2.

The CS-IBCF shall not screen SIP parameters for which there is a related ISUP parameter defined within ITU-T Recommendation Q.1912.5 [6].

NOTE 2: SIP-I screening is normally done by the GMSC, where the encapsulated ISUP message and the SIP headers are consistently screened.

Upon receiving an incoming initial request for which network topology hiding has to be applied and which includes a Record-Route header, the CS-IBCF shall add its own routable SIP URI to the top of the Record-Route header.

A.5.3.4.2 Decryption for network topology hiding

Upon receiving a request/response, incoming to the hiding network, the CS-IBCF shall perform the decryption for network topology hiding purposes, i.e. the CS-IBCF shall:

- 1) identify hostnames encrypted by the network this CS-IBCF belongs to within all headers of the incoming message;
- 2) use those hostnames that carry the identification of the hiding network within the value of the "tokenized-by" parameter as input to decryption;
- 3) use as encrypted string the hostname which follows the sent-protocol (for Via Headers, e.g. "SIP/2.0/UDP") or the URI scheme (for Route and Record-Route Headers, e.g. "sip:");
- 4) replace all content of the received header which carries encrypted information with the entries resulting from decryption.

EXAMPLE: An encrypted entry to a Via header that looks like:

```
Via: SIP/2.0/UDP Token(SIP/2.0/UDP msc2.home1.net;lr,  
SIP/2.0/UDP msc1.home1.net;lr);tokenized-by=home1.net
```

will be replaced with the following entries:

```
Via: SIP/2.0/UDP msc2.home1.net;lr, SIP/2.0/UDP msc1.home1.net;lr
```

NOTE: Motivations for these decryption procedures are e.g. to allow the correct routing of a response through the hiding network, to enable loop avoidance within the hiding network, or to allow the entities of the hiding network to change their entries within e.g. the Record-Route header.

A.5.3.5 ALG functionality in the CS-IBCF

The CS-IBCF shall only apply the following procedures if application level gateway functionality is required by the network.

The CS-IBCF acts as a B2BUA when it performs ALG functionality. The CS-IBCF, although acting as a UA, does not initiate any registration of its associated addresses. These are assumed to be known by peer-to-peer arrangements within the SIP-I based CS domain.

When the CS-IBCF receives an initial INVITE request from another SIP network, the CS-IBCF shall generate a new initial INVITE request and forward it to the (G)MSC Server.

The internal function of the CS-IBCF as an ALG is equal to that one defined in 3GPP TS 29.162 [37].

A.5.3.6 Screening of SIP-I signalling

The text in subclause A.5.2.6 applies without changes.

A.5.3.7 Void

A.6 Procedures at the CS-TrGW

A.6.1 Transport Plane Control procedures

A.7 CS-IBCF – CS-TrGW Interaction

A.7.1 General

A.7.1.1 Network Model

Figure A.7.1.1.1 shows the network model. The broken line represents the call control signalling. The dotted line represents the bearer control signalling (if applicable) and the user plane. The CS-IBCF uses one context with two terminations in the TrGW. The termination T1 is used towards the 3GPP PLMN and the bearer termination T2 is used for the bearer towards the external IP network.

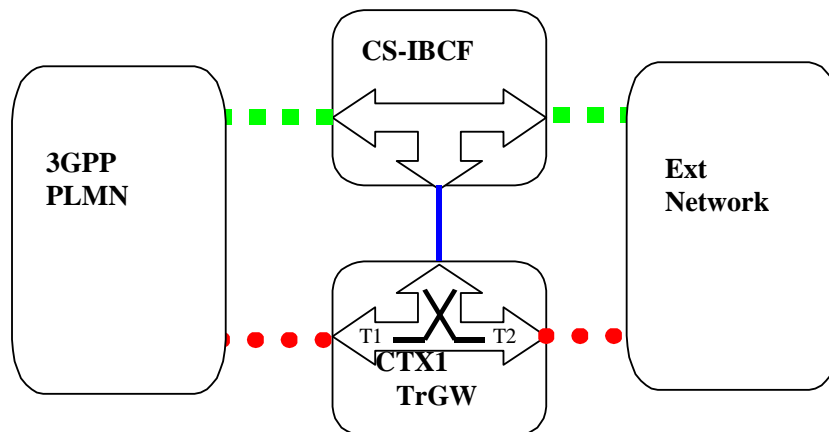

Figure A.7.1.1.1: H.248 Context Model

A.7.1.2 Signalling flows

A.7.1.2.1 Basic Procedures

A.7.1.2.1.1 Call Establishment

Figure A.7.1.2.1.1.1 depicts the signalling flow for a call setup from external network towards 3GPP PLMN. The same signalling flow applies for a call setup from the 3GPP PLMN towards an external network with the exception that terminations T1 and T2 are then exchanged.

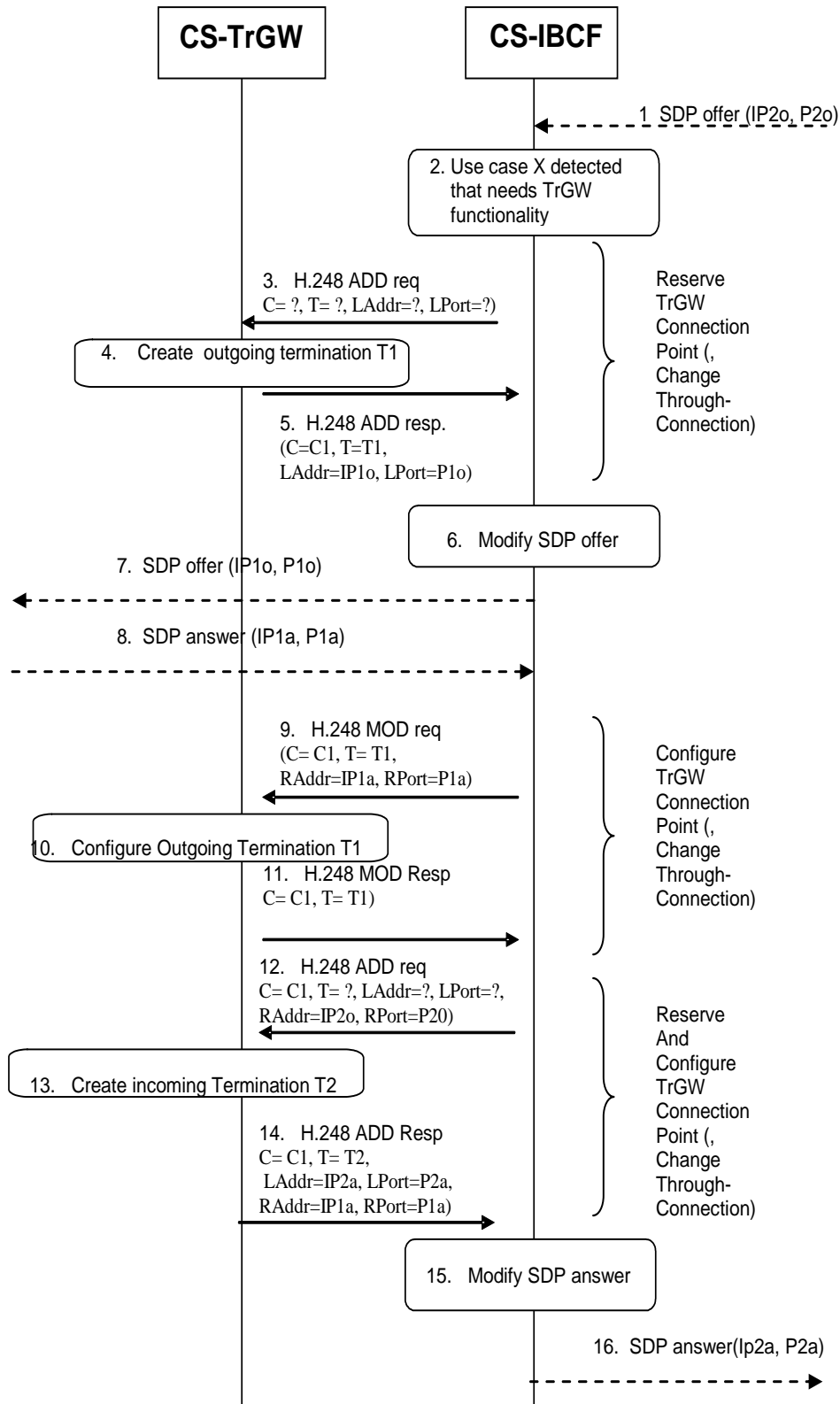

1. The CS-IBCF receives an SDP offer in SIP signalling.
2. The CS-IBCF detects that one of the CS-TrGW functions is required, e.g. NAPT/NAT
3. The CS-IBCF sends a H.248 ADD command to create the outgoing termination and to request resources to execute CS-TrGW function
4. The CS-TrGW creates the outgoing termination
5. The CS-TrGW replies to CS-IBCF with a H.248 Add reply command and provides the local address and port of the outgoing termination
6. The CS-IBCF replaces the IP address inside the SDP using the information coming from CS-TrGW
7. SDP offer is sent to the network at the outgoing side
8. SDP answer is received by CS-IBCF

9. The CS-IBCF sends a H.248 MOD command to configure the outgoing termination with Address and port information received in the SDP answer
 10. The CS-TrGW configures the outgoing termination
 11. The CS-TrGW replies to CS-IBCF with a H.248 MOD reply command
 12. The CS-IBCF sends a H.248 ADD command to create the incoming termination and to request resources to execute CS-TrGW function
 13. The CS-TrGW creates the incoming termination
 14. The CS-TrGW replies to the CS-IBCF with a H.248 Add reply command and provides the local address and port of the incoming termination.
- Note:
- Steps 12 to 14 may also be executed after step 2.
 15. The CS-IBCF replaces the IP address inside the SDP using the information coming from CS-TrGW
 16. SDP answer is sent to the network at the incoming side

Figure A.7.1.2.1.1: CS-IBCF and CS-TrGW interaction at Call establishment.

When creating the termination T1, the CS-IBCF may also indicate that the IP Interface type is "NboIP".

When creating the termination T2, the CS-IBCF may also indicate that the IP Interface type is "ExtSIPi".

NOTE: The IP Interface Type allows the CS-TrGW to collect statistics per interface type associated with the RTP bearer termination as required by 3GPP TS 32.407 [44]. The provision of these statistics is outside of the scope of this specification.

A.7.1.2.1.2 Call Release

Figure A.7.1.2.1.2.1 depicts the signalling flow for a call release.

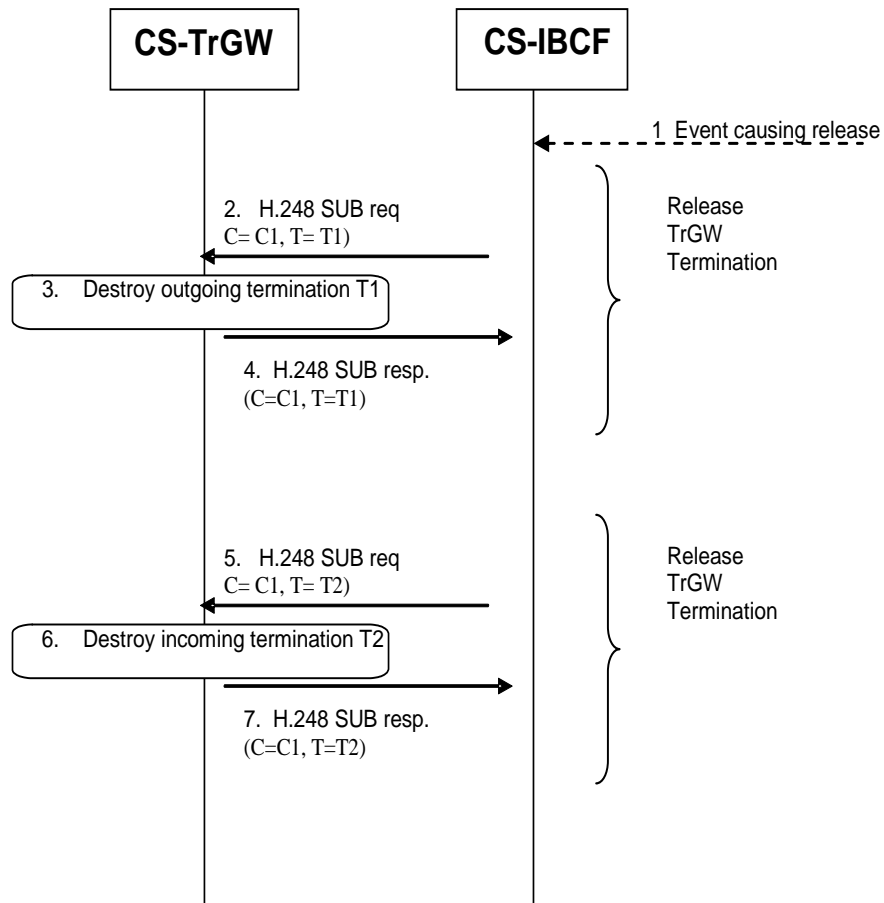

1. The CS-IBCF identifies that the call is to be released. Typically this will be by the receipt of a SIP BYE request.
2. The CS-IBCF sends a H.248 SUB command to release the outgoing termination
3. The CS-TrGW destroys the outgoing termination
4. The CS-TrGW replies to CS-IBCF with a H.248 Sub reply command
5. The CS-IBCF sends a H.248 SUB command to release the incoming termination
6. The CS-TrGW destroys the incoming termination
7. The CS-TrGW replies to CS-IBCF with a H.248 Sub reply command

Note 1: Steps 5 to 7 may also be executed before steps 2 to 4 or in parallel with steps 2 to 4.

Note 2: Rather than releasing the two terminations separately, the CS-IBCF may request the CS-TrGW to release both terminations in a single request.

Figure A.7.1.2.1.2.1: CS-IBCF and CS-TrGW interaction at Call release

A.7.1.2.2 Specific Use Cases

A.7.1.2.2.1 CS-IBCF as Entry Point, Call Establishment with IP Version Interworking

This case considers the call establishment message flow for the CS-IBCF and CS-TrGW, when the CS-IBCF is acting as an Entry point and IP version interworking is required. The example assumes that the external SIP-I network uses IPv4 addressing and the CS CN uses IPv6 addressing.

With reference to the steps in figure A.7.1.2.1.1.1, the following additions are required, specific to this use case:

3. The CS-IBCF requests the CS-TrGW to choose an IPv6-based local connection address for the created outgoing termination.
5. The local address and port returned to the CS-IBCF are IPv6-based.
6. Specifically, the IPv6 address and port number received from the CS-TrGW in the local connection address of the outgoing termination replace the IPv4 address and port number received from the external SIP-I network.
9. Specifically, the CS-IBCF passes the IPv6 address and port number received in the SDP answer to the CS-TrGW as the remote connection address on the outgoing termination.
12. The CS-IBCF requests the CS-TrGW to choose an IPv4-based local connection address on the incoming termination. The CS-IBCF uses the IPv4 addresses and port numbers received in the initial SDP offer as the remote connection address on the incoming termination.
14. The local address and port returned to the CS-IBCF are IPv4-based.
15. Specifically, the IPv4 address and port number received from the CS-TrGW in the local connection address of the incoming termination replace the IPv6 address and port number received from the CS-CN.

A.7.1.2.2.2 Hanging Termination Detection

This subclause considers the message flow for the CS-IBCF and CS-TrGW, when IP hanging termination detection is required. Hanging termination detection procedure allows the CS-IBCF to detect a hanging context and termination in the TrGW resulting, for example, from a loss of communication between the CS-IBCF and the CS-TrGW.

When the CS-IBCF requests the CS-TrGW to reserve terminations, the CS-IBCF shall also request the CS-TrGW to periodically report termination heartbeat indications. If the CS-IBCF includes an indication of the periodicity of the termination heartbeat notifications, the specified period shall be much greater than the mean call holding time.

The CS-IBCF and the CS-TrGW shall support detection of hanging terminations.

The call is established as described in subclause A.7.1.2.1.1. With reference to the steps in figure A.7.1.2.1.1, the following additions are required, specific to this use case:

3. The CS-IBCF requests the CS-TrGW to send termination heartbeat notifications for the created termination. It may also include an indication of the periodicity of the termination heartbeat notifications.
12. The CS-IBCF requests the CS-TrGW to send termination heartbeat notifications for the created termination. It may also include an indication of the periodicity of the termination heartbeat notifications.

Subsequently, the CS-TrGW shall periodically send termination heartbeat notifications, as shown in figure A.7.1.2.2.1, until the call is released.

When the CS-IBCF receives a termination heartbeat notification from the CS-TrGW via the Termination heartbeat - Indication procedure, the CS-IBCF shall return a Termination heartbeat - Indication Ack (without an error) if the

context id / termination identity combination exists in the CS-IBCF. If this combination does not exist, the CS-IBCF shall return an error and shall correct the mismatch, for example by requesting the CS-TrGW to subtract the indicated termination and to clear any associated context.

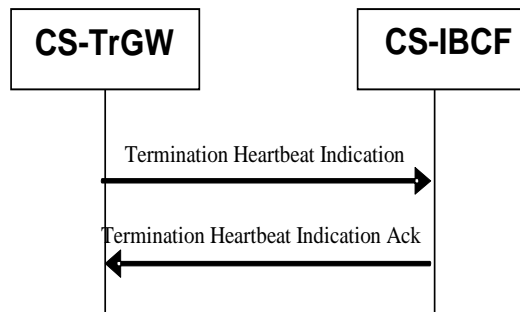

Figure A.7.1.2.2.2.1: CS-IBCF and CS-TrGW interaction for termination heartbeat notifications

A.7.1.2.2.3 Gate Management

This subclause considers the message flow for the CS-IBCF and CS-TrGW, when the CS-IBCF is acting as an Entry point and remote source address filtering is required for the termination towards the external SIP-I network.

Gate Management shall be a mandatory feature of the CS-TrGW, but an optional feature of the CS-IBCF.

As a security related option, on request from the CS-IBCF, filtering may be enabled to check/validate the source address or source address and port number of incoming packets from the external network. If the CS-IBCF requests address filtering, it may additionally provide an address specification, which may identify either a single address or a range of addresses, against which filtering is to be performed. The absence of such an address specification in the request implicitly requests filtering against the IP address of the remote connection address. In addition to address filtering, the CS-IBCF may also request port filtering. If the CS-IBCF requests port filtering, it may additionally include either a port or a range of ports, against which filtering is to be performed. The absence of a port specification in the request implicitly requests filtering against the port of the remote connection address.

If the CS-TrGW is configured to apply source IP address and possibly source port filtering, it shall only pass incoming IP packets from the identified source, and discard IP packets from other sources.

The call is established as described in subclause A.7.1.2.1.1. With reference to the steps in figure A.7.1.2.1.1.1, the following additions are required, specific to this use case:

12. If remote source address filtering is required for the created termination, then the CS-IBCF includes the information element "Remote source address filtering" in the request sent to the CS-TrGW. In addition, it may also include the information element "Remote source address mask".
If remote source port filtering is required for the created termination (in addition to remote source address filtering), then the CS-IBCF includes the information element "Remote source port filtering" in the request sent to the CS-TrGW. It may also include one of the information elements "Remote source port" or "Remote source port range".

Subsequently, the CS-TrGW applies filtering as requested to the packets arriving from the external network. Any packet arriving, which does not meet the filtering requirement, is discarded.

A.7.1.2.2.4 QoS Packet Marking

This subclause considers the message flow for the CS-IBCF and CS-TrGW, when the CS-IBCF requires the use of differentiated services (see IETF RFC 2474 [41]).

It is optional for the CS-IBCF to support differentiated service controlled over the Ix Interface. It shall be mandatory for the CS-TrGW to support differentiated service controlled over the Ix Interface. A CS-TrGW can also support DiffServ Code Point marking based on local configuration. The CS-IBCF may request the CS-TrGW to set diffserv codepoints for outgoing packets on a termination. The CS-IBCF may either indicate the applicable DSCP value or configure the TrGW to copy the DSCP value in the corresponding received packet. When the CS-IBCF requests the CS-TrGW to create a termination and if differentiated services are required for the created termination, the CS-IBCF shall include the information elements "DiffServ Code Point" and/or "DiffServ Tagging Behaviour" in the request sent to the CS-TrGW.

The call is established as described in subclause A.7.1.2.1.1. With reference to the steps in figure A.7.1.2.1.1.1, the following additions are required, specific to this use case:

3. If differentiated services are required for the created termination, then the CS-IBCF includes the information elements "DiffServ Code Point" and/or "DiffServ Tagging Behaviour" in the request sent to the CS-TrGW.
12. If differentiated services are required for the created termination, then the CS-IBCF includes the information elements "DiffServ Code Point" and/or "DiffServ Tagging Behaviour" in the request sent to the CS-TrGW.

Subsequently, for all egress packets, the CS-TrGW shall set the DiffServ Code Point in the IP header as specified by the CS-IBCF:

- If the DiffServ Tagging Behaviour information element was received with a value to indicate that the DiffServ Code Point should be copied, then the CS-TrGW shall copy the DiffServ Code Point in the IP header of the egress packet from the ingress packet.
- If the DiffServ Tagging Behaviour information element was not received, or was received with a value to indicate that the DiffServ Code Point should be set to a specific value, then:
 - If the DiffServ Code Point information element was received, then the CS-TrGW shall set the DiffServ Code Point in the IP header of the egress packet to the value received in the DiffServ Code Point information element.
 - If the DiffServ Code Point information element was not received, then the CS-TrGW may set the DiffServ Code Point in the IP header of the egress packet to a configured default value.

A.7.1.2.2.5 IP Realms

This subclause considers the message flow for the CS-IBCF and CS-TrGW, when the two networks are in different IP realms. IP realms are described in 3GPP TS 23.205 [9] clause 20.

The CS-IBCF and the CS-TrGW shall support IP realm indication.

The call is established as described in subclause A.7.1.2.1.1. With reference to the steps in figure A.7.1.2.1.1.1, the following additions are required, specific to this use case:

3. The CS-IBCF may specify the required IP Realm.
4. The CS-TrGW allocates resources from the appropriate IP realm as specified by the CS-IBCF in step 3.
12. The CS-IBCF may specify the required IP Realm.
13. The CS-TrGW allocates resources from the appropriate IP realm as specified by the CS-IBCF in step 12.

If there is a change in the IP Realms that are available or if they are modified in the CS-TrGW then the CS-TrGW shall inform the CS-IBCF via the IP Realm Availability Procedure (see subclause A.7.2.3), if this procedure is supported by the CS-TrGW. The basic flow is depicted in figure A.7.1.2.2.5.1

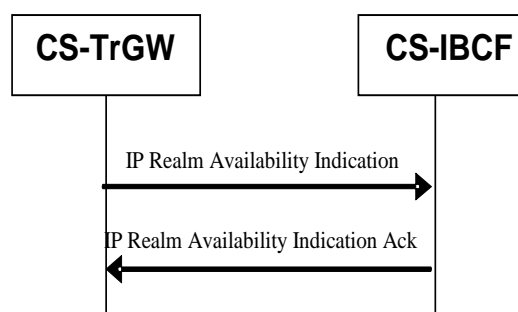

Figure A.7.1.2.2.5.1: IP Realm Availability

The monitoring of IP realm availability is optional and if supported by the CS-TrGW may be requested by the CS-IBCF.

A.7.1.2.2.6 Media Inactivity Detection

The CS- TrGW and the CS-IBCF may support the detection of inactive media flows.

The CS-IBCF may request a CS-TrGW that supports media inactivity detection to detect if a media flow is inactive.

NOTE: The decision to apply or not to apply media inactivity detection is general for all sessions with the same media characteristics (i.e. not user specific). Detailed conditions when media inactivity detection can be requested are not specified in the present release.

When the CS-IBCF requests the CS-TrGW to reserve transport addresses/resources, the CS-IBCF may indicate to the CS-TrGW that detection of an inactive media flow is required and may additionally specify inactivity detection time and inactivity detection direction. The IBCF may request the detection of media inactivity on a termination or a stream basis.

The call is established as described in subclause A.7.1.2.1.1. With reference to the steps in figure A.7.1.2.1.1.1, the following additions are required, specific to this use case:

3. The CS-IBCF indicates to the CS-TrGW that detection of an inactive media flow is required and can additionally specify inactivity detection time and inactivity detection direction.
12. The CS-IBCF indicates to the CS-TrGW that detection of an inactive media flow is required and can additionally specify inactivity detection time and inactivity detection direction.

The CS- TrGW shall determine a media flow to be inactive if there is no media sent and/or received within the inactivity detection time period.

When the CS-IBCF receives a notification of inactive media from the CS-TrGW via the Media Inactivity Notification procedure, the CS-IBCF shall return a Media Inactivity Notification Ack and shall take appropriate action (e.g. release the termination).

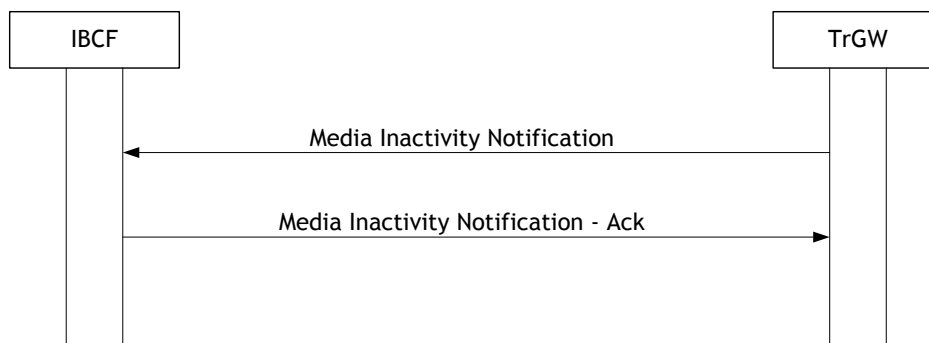

Figure A.7.1.2.2.6.1: Media Inactivity Notification

A.7.1.2.2.7 RTCP Handling

The CS-IBCF and the CS-TrGW shall support control via the Ix interface of the specific RTCP behaviour associated to an RTP flow.

When the CS-IBCF requests the CS-TrGW to reserve transport addresses/resources for an RTP flow, the CS-IBCF may indicate to the CS-TrGW whether to reserve corresponding RTCP resources should also request the CS-TrGW to reserve resources for the corresponding RTCP flow, but may alternatively request the CS-TrGW not to reserve resources for the corresponding RTCP flow. When the CS-IBCF requests the CS-TrGW to reserve transport addresses/resources for a non-RTP flow, the CS-IBCF shall not request the CS-TrGW to reserve resources for an RTCP flow.

To request the CS-TrGW to reserve resources for an RTCP flow, the CS-IBCF shall provide the RTCP handling information element with a value indicating that resources for RTCP shall be reserved.

To request the CS-TrGW not to reserve resources for an RTCP flow, the CS-IBCF shall either provide the RTCP handling information element with a value indicating that resources for RTCP shall not be reserved or omit the RTCP handling information element.

If the CS-TrGW receives the indication to reserve RTCP resources, the TrGW shall allocate a local port with even number for an RTP flow also reserve the consecutive local port with odd number for the associated RTCP flow, and it shall send and be prepared to receive RTCP.

If the CS-TrGW receives the indication to not reserve RTCP resources, or does not receive any indication, it shall not allocate an RTCP port when allocating a port for an RTP flow. The CS-TrGW shall not send any RTCP packets and shall silently discard any received RTCP packets.

When RTCP resources are requested, the CS-IBCF may also specify:

- the remote RTCP port, and optionally the remote address, where to send RTCP packets; if not specified, the CS-TrGW shall send RCTP packets to the port contiguous to the remote RTP port;
- bandwidth allocation requirements for RTCP, if the RTCP bandwidth level for the session is different than the default RTCP bandwidth as specified in RFC 3556 [39].

NOTE: In line with the recommendations of RFC 3605 [40], separate address or non-contiguous RTCP port numbers will not be allocated by the TrGW.

The CS-TrGW shall return an error if it can not allocate the requested RTCP resources.

The call is established as described in subclause A.7.1.2.1.1. With reference to the steps in figure A.7.1.2.1.1.1, the following additions are required, specific to this use case:

3. The CS-IBCF may specify if RTCP handling is required.
4. The CS-TrGW allocates RTCP resources as specified by the CS-IBCF in step 3.
12. The CS-IBCF may specify if RTCP handling is required.
13. The CS-TrGW allocates RTCP as specified by the CS-IBCF in step 12.

A.7.1.2.2.8 Bandwidth Policing

A.7.1.2.2.8.1 Overview

The CS-IBCF may support traffic policing of incoming media flows.

The CS-TrGW shall support traffic policing of the maximum average bitrate, defined as sustainable data rate (see IETF RFC 2216 [42]) of incoming media flows and may support traffic policing of the peak data rate of incoming media flows.

The CS-IBCF may require the CS-TrGW to police the media flows to ensure that they conform to the expected data rates.

When the CS-IBCF requests the CS-TrGW to reserve transport addresses/resources, the CS-IBCF may indicate to the CS-TrGW that policing of the related media streams is required and provide traffic policing related parameters as detailed in subclause A.7.1.2.2.8.2.

If such policing is requested, the CS-TrGW shall police the corresponding media streams as detailed in subclause A.7.1.2.2.8.2, by measuring the data rate for the received packets within that media stream. If the permissible data rate provided by the CS-IBCF is exceeded, the CS-TrGW shall discard packets to reduce their data rate to the permissible data rate.

A.7.1.2.2.8.2 Bandwidth policing procedures

The call is established as described in subclause A.7.1.2.1.1. With reference to the steps in figure A.7.1.2.1.1.1, the following additions are required, specific to this use case:

3. If traffic policing is required for the created termination, then the CS-IBCF shall include the information element "Traffic Policing Required" in the request sent to the CS-TrGW. If policing of sustainable data rate is required, then the CS-IBCF shall include the information elements "Sustainable Data Rate" and "Maximum Burst Size" in the request. If policing of peak data rate is required, then the CS-IBCF shall include the information element "Peak Data Rate" in the request and may additionally include the information element "Delay Variation Tolerance".
12. If traffic policing is required for the created termination, then the CS-IBCF shall include the information element "Traffic Policing Required" in the request sent to the CS-TrGW. If policing of sustainable data rate is required, then the CS-IBCF shall include the information elements "Sustainable Data Rate" and "Maximum Burst Size" in the request. If policing of peak data rate is required, then the CS-IBCF shall include the information element "Peak Data Rate" in the request and may additionally include the information element "Delay Variation Tolerance".

When requested by the CS-IBCF, the CS-TrGW shall police the media stream flow rates according to one or more of the following media policing(s), in accordance with IETF RFC 2216 [42].

The following media policing shall be supported at the CS-TRGW :

- **Sustainable Data Rate (SDR) Policing:**

To request policing of the sustainable data rate of a media stream, the CS-IBCF shall request media policing for that media stream and shall provide the sustainable data rate, and shall provide a maximum burst size (MBS) indicating the expected maximum size of packet bursts for that media stream. The CS-TrGW shall then measure the data rate for the received packets within that media stream as per IETF RFC 2216 [42] for "Token Bucket", where $r=SDR$ and $b=MBS$. If the permissible sustainable data rate is exceeded, the CS-TRGW shall discard packets to reduce the data rate to the permissible sustainable data rate.

NOTE 1: The CS-IBCF can derive the sustainable data rate from bandwidth parameters if it receives them within an SDP description.

The following media policing may be supported in addition at the CS-TRGW; if supported, then the following applies:

- **Peak Data Rate Policing:**

To request policing of the peak data rate of a media stream, the CS-IBCF shall request media policing for that media stream and shall provide the peak data rate, and may provide a Delay Variation Tolerance indicating the expected maximum delay variation due to jitter for that media stream. The CS-TRGW shall then measure the data rate for the received packets within that media stream. If the permissible peak data rate is exceeded, the CS-TRGW shall discard packets to reduce the data rate to the permissible peak data rate. If both peak data rate and sustainable data rate have been provided for the same media stream, the CS-TRGW shall discard packets to reduce the data rate to the permissible peak data rate and should discard packets to reduce the data rate to the permissible sustainable data rate.

NOTE 2: The decision to apply or not traffic policing is general for all sessions with the same media characteristics (i.e. not user specific). The conditions which media policings to apply are beyond the scope of the specification. This can be based on the media characteristics of the session (e.g. media type).

A.7.1.2.2.9 Through-Connection

The Change Through-Connection procedure is mandatory for CS-IBCF and CS-TrGW to support.

The CS-IBCF sets the Stream mode parameter using the Change Through-Connection procedure to request the CS-TrGW to both-way or one-way through-connect or block media streams on a termination.

The CS-IBCF may combine the Change Through-Connection procedure with the Reserve and Configure TrGW Connection Point, Reserve TrGW Connection Point or Configure TrGW Connection Point procedure in figure A.7.1.2.1.1.1., or may apply this procedure separately.

A.7.1.2.2.10 Emergency Call

This procedure is identical to that of subclause A.7.1.2.1.1 apart from the CS-IBCF requesting the CS-TrGW to treat the call as emergency call with a preferential handling by including the information element "Emergency Call Indicator" when creating a context within the "Reserve and Configure TrGW Connection Point" or "Reserve TrGW Connection Point" procedure.

With reference to the steps in figure A.7.1.2.1.1, the following additions are required, specific to this use case:

3. If step 3 is performed before step 13, the CS-IBCF requests the CS-TrGW to handle the call as emergency call by including the "Emergency Call Indicator".
13. If step 13 is performed before step 3, the CS-IBCF requests the CS-TrGW to handle the call as emergency call by including the "Emergency Call Indicator".

A.7.2 Ix Signalling Procedures

A.7.2.1 Introduction

This subclause describes the logical signalling procedures (i.e. message identifiers are not part of the protocol) between the CS-IBCF and CS-TrGW. The procedures within this subclause are intended to be implemented using the standard H.248 procedure as defined in ITU-T Recommendation H.248.1 [33] with appropriate parameter combinations.

A.7.2.2 Call Related Procedures

A.7.2.2.1 Reserve TrGW Connection Point

This procedure is used to reserve a termination at the CS-TrGW.

Table A.7.2.2.1.1: Reserve TrGW Connection Point

Procedure	Initiated	Information element name	Information element required	Information element description
Reserve TrGW Connection Point	CS-IBCF	Context/Context Request	M	This information element indicates the existing context or requests a new context for the bearer termination.
		Emergency Call Indicator	O	This information element identifies the call as emergency call that requires a preferential handling.
		Termination Request	M	This information element requests a new termination for the bearer to be established.
		IP Interface	O	This information element specifies the type of external interface to be used for the IP termination (e.g. ExtSIPi, NboIP).
		Local IP Resources	O	This information element indicates the resource(s) (e.g. codec, auxiliary payload types) for which the CS-TrGW shall be prepared to receive user data.
		ReserveValue	C	This information element indicates if multiple local resources are to be reserved. This information element shall be included if a speech codec and auxiliary payload types are configured.
		Local Connection Address Request	M	This information element requests an IP address and port number on the CS-TrGW that the remote end can send user plane data to.
		Notify termination heartbeat	M	This information element requests termination heartbeat indications and may specify their periodicity.
		Notify Released Bearer	O	This information element requests a notification of a released bearer.
		IP Realm Identifier	O	This information element indicates the IP realm of the IP termination.
		IP Version	C	This information element indicates the version of the internet protocol to be applied at the termination for the user plane. This is required for IP address translation.
		DiffServ Code Point	O	This information element indicates a specific DiffServ code point to be used in the IP header in packets sent on the IP termination.
		DiffServ Tagging Behaviour	O	This information element indicates whether the DiffServ code point in the IP header in packets sent on the IP termination should be copied from the received value or set to a specific value.
		Remote Source Address Filtering	O	This information element indicates that remote source address filtering is required.
		Remote Source Address Mask	C	This information element provides information on the valid remote source addresses. This may be included if remote source address filtering is included. It shall not be included if remote source address filtering is not included.
Remote Source Port Filtering	O	This information element indicates that remote source port filtering is required.		

		Remote Source Port	C	This information element identifies the valid remote source port. This may be included if remote source port filtering is included. It shall not be included if remote source port filtering is not included. (NOTE 1)
		Remote Source Port Range	C	This information element identifies a range of valid remote source ports. This may be included if remote source port filtering is included. It shall not be included if remote source port filtering is not included. (NOTE 1)
		Media Inactivity Detection Required	O	This information element indicates that detection of inactive media flows is required.
		Inactivity Detection Time	C	This information element may be present if Inactive Media Detection is required and specifies the Inactivity Detection time.
		Inactivity Detection Direction	C	This information element may be present if Inactive Media Detection is required and specifies the Inactivity Detection direction.
		RTCP handling	O	Indicates whether or not the CS-TrGW shall reserve a port for an RTCP flow.
		Traffic Policing Required	O	This information element indicates that policing of the media flow is required.
		Peak Data Rate	O	This information element may be present if Policing is required and specifies the permissible peak data rate for a media stream. (NOTE 2)
		Sustainable Data Rate	O	This information element may be present if Policing is required and specifies the permissible sustainable data rate for a media stream. (NOTE 2)
		Delay Variation Tolerance	O	This information element may be present if Policing on Peak Data Rate is required and specifies the maximum expected delay variation tolerance for the corresponding media stream.
		Maximum Burst Size	C	This information element shall be present if Policing on Sustainable Data Rate is required and specifies the maximum expected burst size for the corresponding media stream.
Reserve TrGW Connection Point Ack	CS-TrGW	Context	M	This information element indicates the context where the command was executed.
		Termination	M	This information element indicates the termination where the command was executed.
		Local IP Resources	C	This information element indicates the resources that the CS-TrGW has reserved to receive the user plane data from the remote peer. This IE shall be present if it was contained in the request. If the IE was not contained in the request, it may be present in the reply.
		Local Connection Address	M	This information element indicates the IP address and port on the CS-TrGW that shall receive user plane data from the remote peer.
NOTE 1: Remote Source Port and Remote Source Port Range are mutually exclusive.				
NOTE 2: At least one of these IEs shall be present when policing is required.				

A.7.2.2.2 Configure TrGW Connection Point

This procedure is used to configure or reconfigure a termination at the CS-TrGW.

Table A.7.2.2.1: Configure TrGW Connection Point

Procedure	Initiated	Information element name	Information element required	Information element description
Configure TrGW Connection Point	CS-IBCF	Context	M	This information element indicates the existing context.
		Termination	M	This information element indicates the existing bearer termination.
		IP Interface	O	This information element specifies the type of external interface to be used for the IP termination (e.g. ExtSIPI, NboIP).
		Local IP Resources	O	This information element indicates the resources (e.g. codec, auxiliary payload types) that the CS-TrGW may use on the reception of user plane data.
		Remote IP Resources	O	This information element indicates the resources (e.g. codec, auxiliary payload types) that the CS-TrGW may send user plane data to.
		Local Connection Address	O	This information element indicates the IP address and port on the CS-TrGW that the remote peer can send user plane data to.
		Remote Connection Address	O	This information element indicates the IP address and port that the CS-TrGW can send user plane data to.
		Reserve Value	O	This information element indicates if multiple resources are to be reserved.
		Notify termination heartbeat	O	This information element requests termination heartbeat indications and may specify their periodicity.
		DiffServ Code Point	O	This information element indicates a specific DiffServ code point to be used in the IP header in packets sent on the IP termination.
		DiffServ Tagging Behaviour	O	This information element indicates whether the DiffServ code point in the IP header in packets sent on the IP termination should be copied from the received value or set to a specific value.
		Remote Source Address Filtering	O	This information element indicates that remote source address filtering is required.
		Remote Source Address Mask	C	This information element provides information on the valid remote source addresses. This may be included if remote source address filtering is included. It shall not be included if remote source address filtering is not included.
		Remote Source Port Filtering	O	This information element indicates that remote source port filtering is required.
Remote Source Port	C	This information element identifies the valid remote source port. This may be included if remote source port filtering is included. It shall not be included if remote source port filtering is not included. (NOTE 1)		
Remote Source Port Range	C	This information element identifies a range of valid remote source ports. This may be included if remote source port filtering is included. It shall not be included if remote source port filtering is not included. (NOTE 1)		

		Media Inactivity Detection Required	O	This information element indicates that detection of inactive media flows is required.
		Inactivity Detection Time	C	This information element may be present if Inactive Media Detection is required and specifies the Inactivity Detection time.
		Inactivity Detection Direction	C	This information element may be present if Inactive Media Detection is required and specifies the Inactivity Detection direction.
		RTCP handling	O	Indicates whether or not the CS-TrGW shall reserve a port for an RTCP flow.
		Traffic Policing Required	O	This information element indicates that policing of the media flow is required.
		Peak Data Rate	O	This information element may be present if Policing is required and specifies the permissible peak data rate for a media stream.(NOTE 2)
		Sustainable Data Rate	O	This information element may be present if Policing is required and specifies the permissible sustainable data rate for a media stream.(NOTE 2)
		Delay Variation Tolerance	O	This information element may be present if Policing on Peak Data Rate is required and specifies the maximum expected delay variation tolerance for the corresponding media stream.
		Maximum Burst Size	C	This information element shall be present if Policing on Sustainable Data Rate is required and specifies the maximum expected burst size for the corresponding media stream.
Configure TrGW Connection Point Ack	CS-TrGW	Context	M	This information element indicates the context where the command was executed.
		Termination	M	This information element indicates the termination where the command was executed.
		Local IP Resources	O	This information element indicates the resources that the CS-TrGW has reserved to receive the user plane data from the far end.
		Remote IP Resources	O	This information element indicates the resource (i.e. codec) that the CS-TrGW shall use to send user data to.
		Local Connection Address	O	This information element indicates the IP address and port on the CS-TrGW that the remote end can send user plane data to.
		Remote Connection Address	O	This information element indicates the IP address and port that the CS-TrGW can send user plane data to. May be present only if corresponding IE is present in the request.
NOTE 1: Remote Source Port and Remote Source Port Range are mutually exclusive.				
NOTE 2: At least one of these IEs shall be present when policing is required.				

A.7.2.2.3 Reserve and Configure TrGW Connection Point

This procedure is used to reserve and configure multimedia-processing resources for a termination at the CS-TrGW.

Table A.7.2.3.1: Reserve and Configure TrGW Connection Point

Procedure	Initiated	Information element name	Information element required	Information element description
Reserve and Configure TrGW Connection Point	CS-IBCF	Context/Context Request	M	This information element indicates the existing context or requests a new context for the bearer termination.
		Emergency Call Indicator	O	This information element identifies the call as emergency call that requires a preferential handling.
		Termination/Termination Request	M	This information element indicates the existing bearer termination or requests a new termination for the bearer to be established.
		IP Interface	O	This information element specifies the used interface type for the IP termination (e.g. ExtSIPi, NboIP).
		Local IP Resources	O	This information element indicates the resource(s) (e.g. codec, auxiliary payload types) for which the CS-TrGW shall be prepared to receive user data,
		Remote IP Resources	O	This information element indicates the resources (e.g. codec, auxiliary payload types) that the CS-TrGW shall use to send user data.
		Reserve Value	O	This information element indicates if multiple IP resources are to be reserved.
		Local Connection Address request	M	This information element requests an IP address and a port number on the CS-TrGW that the remote end can send user plane data to.
		Remote Connection Address	M	This information element indicates the IP address and ports of the remote party that the CS-TrGW can send user plane data to.
		Notify termination heartbeat	M	This information element requests termination heartbeat indications and may specify their periodicity.
		Notify Released Bearer	O	This information element requests a notification of a released bearer.
		IP Realm Identifier	O	This information element indicates the IP realm of the IP termination.
		IP Version	C	This information element indicates the version of the internet protocol to be applied at the termination for the user plane. This is required for IP address translation.
		DiffServ Code Point	O	This information element indicates a specific DiffServ code point to be used in the IP header in packets sent on the IP termination.
		DiffServ Tagging Behaviour	O	This information element indicates whether the Diffserv code point in the IP header in packets sent on the IP termination should be copied from the received value or set to a specific value.
		Remote Source Address Filtering	O	This information element indicates that remote source address filtering is required.
Remote Source Address Mask	C	This information element provides information on the valid remote source addresses. This may be included if remote source address filtering is included. It shall not be included if remote source address filtering is not included.		
Remote Source Port Filtering	O	This information element indicates that remote source port filtering is required.		

		Remote Source Port	C	This information element identifies the valid remote source port. This may be included if remote source port filtering is included. It shall not be included if remote source port filtering is not included. (NOTE 1)
		Remote Source Port Range	C	This information element identifies a range of valid remote source ports. This may be included if remote source port filtering is included. It shall not be included if remote source port filtering is not included. (NOTE 1)
		Media Inactivity Detection Required	O	This information element indicates that detection of inactive media flows is required.
		Inactivity Detection Time	C	This information element may be present if Inactive Media Detection is required and specifies the Inactivity Detection time.
		Inactivity Detection Direction	C	This information element may be present if Inactive Media Detection is required and specifies the Inactivity Detection direction.
		RTCP handling	O	Indicates whether or not the CS-TrGW shall reserve a port for an RTCP flow.
		Traffic Policing Required	O	This information element indicates that policing of the media flow is required.
		Peak Data Rate	O	This information element may be present if Policing is required and specifies the permissible peak data rate for a media stream. (NOTE 2)
		Sustainable Data Rate	O	This information element may be present if Policing is required and specifies the permissible sustainable data rate for a media stream. (NOTE 2)
		Delay Variation Tolerance	O	This information element may be present if Policing on Peak Data Rate is required and specifies the maximum expected delay variation tolerance for the corresponding media stream.
		Maximum Burst Size	C	This information element shall be present if Policing on Sustainable Data Rate is required and specifies the maximum expected burst size for the corresponding media stream.
Reserve and Configure TrGW Connection Point Ack	CS-TrGW	Context	M	This information element indicates the context where the command was executed.
		Termination	M	This information element indicates the termination where the command was executed.
		Local IP Resources	C	This information element indicates the resources that the CS-TrGW has reserved to receive the user plane data from the remote side. This IE shall be present if it was contained in the request. If the IE was not contained in the request, it may be present in the reply.
		Remote IP Resources	O	This information element indicates the resource (i.e. codec) that the CS-TrGW shall use to send user data.
		Local Connection Addresses	M	This information element indicates the IP address and port on the CS-TrGW that shall receive user plane data.
		Remote Connection Address	O	This information element indicates the IP address and port that the CS-TrGW can send user plane data to. May be present only if corresponding IE is present in the request.
NOTE 1: Remote Source Port and Remote Source Port Range are mutually exclusive.				
NOTE 2: At least one of these IEs shall be present when policing is required.				

A.7.2.2.4 Release TrGW Termination

This procedure is used to release multimedia-processing resources for a termination at the CS-TrGW.

Table A.7.2.2.4.1: Release TrGW Termination

Procedure	Initiated	Information element name	Information element required	Information element description
Release TrGW Termination	CS-IBCF	Context	M	This information element indicates the existing context.
		Termination	M	This information element indicates the existing bearer termination to be released.
Release TrGW Termination Ack	CS-TrGW	Context	M	This information element indicates the context where the command was executed.
		Termination	M	This information element indicates the termination where the command was executed.

A.7.2.2.5 IP Bearer Released

Table A.7.2.2.5.1: IP Bearer Released

Procedure	Initiated	Information element name	Information element required	Information element description
IP Bearer Released	CS-TrGW	Context	M	This information element indicates the context for the bearer termination.
		Termination	M	This information element indicates the bearer termination where the bearer was released.
		Bearer Released	M	This information element notifies a bearer release.
		Release Cause	M	This information element indicates the cause of a bearer release.
IP Bearer Released Ack	CS-IBCF	Context	M	This information element indicates all context are where the command was executed.
		Termination	M	This information element indicates that Bearer termination is where the command was executed.

A.7.2.2.6 Media Inactivity Detection

This command is used to notify the CS-IBCF of media inactivity on the CS-TrGW.

Table A.7.2.2.6.1: Media Inactivity Notification

Procedure	Initiated	Information element name	Information element required	Information element description
Media Inactivity Notification	CS-TrGW	Context	M	This information element indicates the existing context for the bearer termination.
		Termination	M	This information element indicates that bearer termination is where the media inactivity detection was activated.
		Media Inactivity	M	This information element notifies the CS-IBCF of Media inactivity detection on the bearer termination.
Media Inactivity Notification Ack	CS-IBCF	Context	M	This information element indicates the context where the command was executed.
		Termination	M	This information element indicates the bearer termination where the command was executed.

A.7.2.2.7 Termination heartbeat indication

This command is used by the CS-TrGW to periodically notify the CS-IBCF of a termination heartbeat.

Table A.7.2.2.7.1: Termination heartbeat indication

Procedure	Initiated	Information element name	Information element required	Information element description
Termination heartbeat indication	CS-TrGW	Context	M	This information element indicates the context for the bearer termination.
		Bearer Termination	M	This information element indicates the bearer termination for which the termination heartbeat is reported.
		Termination heartbeat	M	Hanging Termination event
Termination heartbeat indication Ack	CS-IBCF	Context	M	This information element indicates the context where the command was executed.
		Bearer Termination	M	This information element indicates the bearer termination where the command was executed.

A.7.2.2.8 Change Through-Connection

This procedure is used to change the Through-connection in the bearer termination.

Table A.7.2.2.8.1: Change Through-Connection

Procedure	Initiated	Information element name	Information element required	Information element description
Change Through-Connection	CS-IBCF	Context/Context Request	M	This information element indicates the existing context or requests a new context for the bearer termination.
		Bearer Termination/Bearer Termination Request	M	This information element indicates the existing bearer termination or requests a new Bearer termination where the through connection is changed.
		Through-Connection	M	This information element indicates the through-connection of the bearer termination
Change Through-Connection Ack	CS-TrGW	Context	M	This information element indicates the context where the command was executed.
		Bearer Termination	M	This information element indicates the bearer termination where the command was executed.

NOTE: This procedure may be combined with Reserve and Configure TrGW Connection Point, Reserve TrGW Connection Point or Configure TrGW Connection Point procedure. This list of procedures is not exhaustive.

A.7.2.3 Non-Call Related Procedures

A.7.2.3.1 Introduction

The procedures detailed in table A.7.2.3.1 shall be applied for the CS-TrGW handling component of the Ix interface. Where a corresponding procedure in 3GPP TS 23.205 [9] is specified, that procedure shall apply. Where no corresponding procedure in 3GPP TS 23.205 [9] is specified, the procedure is specified in a subclause of this specification.

Table A.7.2.3.1.1: Non-call related procedures

Procedure defined in 3GPP TS 29.238 [29]	Corresponding Procedure defined in 3GPP TS 23.205 [9]	Remarks
TrGW Out of service	MGW Out of Service	
TrGW Communication Up	MGW Communication Up	
TrGW Restoration	MGW Restoration	
TrGW Register	MGW Register	
TrGW Re-register	MGW Re-register	
CS-IBCF Ordered Re-register	(G)MSC Server Ordered Re-register	
CS-IBCF Restoration	(G)MSC Server Restoration	
CS-IBCF Out of Service	(G)MSC Server Out of Service	
Termination Out-of-Service	Termination Out-of-Service	The "Termination Out-of-Service procedure" is also used as a call-related H.248 command
Audit Value	Audit Value	
Command Rejected	Command Rejected	The "Command Rejected" procedure may be used in response both to call-related and non-call-related H.248 Commands.
TrGW Capability Change	Capability Update	
TrGW Resource Congestion Handling – Activate	MGW Resource Congestion Handling – Activate	
TrGW Resource Congestion Handling – Indication	MGW Resource Congestion Handling – Indication	
Inactivity timeout activation	Inactivity timeout activation	
Inactivity timeout indication	Inactivity timeout indication	
Realm Availability Change Activate		See subclause A.7.2.3.2.
Realm Availability Change Indication		See subclause A.7.2.3.3.

A.7.2.3.2 Realm Availability Change - Activate

This procedure is used to activate the realm availability notification mechanism.

Table A.7.2.3.2.1: Realm Availability Change - Activate

Procedure	Initiated	Information element name	Information element required	Information element description
Realm Availability Change – Activate	CS-IBCF	Context	M	This information element indicates the NULL context.
		Root Termination	M	This information element indicates that root termination is where the realm availability change notification mechanism is activated.
		Realm Availability Change Activate	M	This information element requests to activate the realm availability change notification mechanism.
Realm Availability Change -Activate Ack	TrGW	Context	M	This information element indicates the NULL context.
		Root Termination	M	This information element indicates that root termination is where the command was executed.

A.7.2.3.3 Realm Availability Change - Indication

This procedure is used to inform the CS-IBCF that there has been a change to the list of currently available realms.

Table A.7.2.3.3.1: Realm Availability Change - Indication

Procedure	Initiated	Information element name	Information element required	Information element description
Realm Availability Change - Indication	TrGW	Context	M	This information element indicates the NULL context.
		Root Termination	M	This information element indicates that root termination is where the realm availability change notification mechanism was activated.
		Changes to Realm Availability	M	This information element indicates the changes to the list of available realms.
Realm Availability Change - Indication Ack	CS-IBCF	Context	M	This information element indicates the NULL context.
		Root Termination	M	This information element indicates that root termination is where the command was executed.

A.8 (G)MSC – CS-MGW Interaction

A.8.1 General

A.8.1.1 Network Model

figure A.8.1.1.1 shows the network model. The squared line represents the call control signalling. The dotted line represents the bearer control signalling (if applicable) and the user plane. The (G)MSC uses one context with at least two terminations in the CS-MGW. The termination T1 is used towards the 3GPP PLMN and the bearer termination T2 is used for the bearer towards the external IP network.

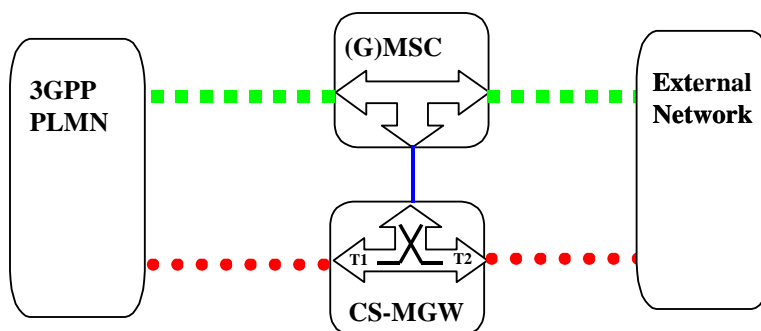

Figure A.8.1.1.1: H.248 Context Model

A.8.1.2 Signalling flows

The signalling flows in A.7.1.2 apply with the following additions:

- Instead of the procedure Reserve TrGW Connection Point the procedure Reserve RTP Connection Point as defined by 3GPP TS 23.205 [9] is used.
- Instead of the procedure Reserve and Configure TrGW Connection Point the procedure Reserve and Configure RTP Connection Point as defined by 3GPP TS 23.205 [9] is used.
- Instead of the procedure Configure TrGW Connection Point the procedure Configure RTP Connection Point as defined by 3GPP TS 23.205 [9] is used.

Annex B (normative): Additional Interworking Procedures between a SIP-I based circuit-switched Core Network and the IP Multimedia (IM) Core Network (CN) Subsystem to Support Special Services

B.1 General

The present annex describes additional interworking between a SIP-I based circuit-switched core network and the IP Multimedia (IM) Core Network (CN) Subsystem to interwork special services such as global text telephony. Those procedures apply in combination with the procedures in clause 7.

The procedures in the present Annex are optional. However, if a special service covered in this Annex is interworked, the procedures in the corresponding subclause of this Annex shall be applied.

B.2 Global Text Telephony

Global Text Telephony (GTT) offers real time conversation in text, optionally combinable with voice. GTT is mainly used for distant conversation with hearing or speech impaired users.

GTT is supported in IMS via the Real-Time Text protocol over RTP, using IETF SIP/SDP for the negotiation of the text media and IETF RFC 4103 [47] RTP-text for transport, with text coded according to ITU-T Recommendation T.140 [46]. See 3GPP TS 23.226 [45], 3GPP TS 26.114 [52], 3GPP TS 26.235 [50] and 3GPP TS 26.236 [51].

Within a SIP-I based circuit-switched Core Network the default PCM codec is used to transport the PTSN inband text telephony format. PCM will also be negotiated as codec within SIP-I/SDP, without further information allowing identifying a call using global text telephony. Different specified systems for text telephony exist as PTSN inband text telephony format and are used in different regions, e.g. Baudot (in US), EDT, V.21, Bell103, Minitel and V.18. They are described in the annexes of ITU-T V.18 [48].

The Interworking procedures in Annex I of TS 29.163 [13] shall be applied with the following clarifications:

- Where ISUP signalling is mentioned or depicted, the corresponding SIP-I signalling is applicable.

Annex C (informative): Change history

Change history							
Date	TSG #	TSG Doc.	CR	Rev	Subject/Comment	Old	New
9/11/07	CT3#46	C3-071058			Agreed skeleton	-	000
1/2/08	CT3#47	C3-080145			Definitions and Terminology for SIP-I Interworking	000	010
1/2/08	CT3#47	C3-080243			Reference model for interworking with external SIP-I network	000	010
1/2/08	CT3#47	C3-080257			SIP-I to SIP-I basic signalling interworking	000	010
1/2/08	CT3#47	C3-080260			Interworking of SIP-I profiles	000	010
1/2/08	CT3#47	C3-080149			User plane interworking towards external SIP-I network	000	010
1/2/08	CT3#47	C3-080152			Interworking Between SIP-I based CS domain and IMS	000	010
3/6/08	CT3#48	C3-080497			Incoming call from external SIP-I network	010	020
3/6/08	CT3#48	C3-080669			Outgoing call towards external SIP-I network	010	020
3/6/08	CT3#48	C3-080670			Handling of Preconditions for incoming calls from external SIP-I network	010	020
3/6/08	CT3#48	C3-080821			Handling of Preconditions for calls towards external SIP-I network	010	020
3/6/08	CT3#48	C3-080794			Section for CS-IBCF and CS-TrGW definition	010	020
4/7/08	CT3#48bis	C3-081192			Handling of unrecognized preconditions by external SIP-I	020	030

					networks		
4/7/08	CT3#48bis	C3-080907			Required preconditions	020	030
4/7/08	CT3#48bis	C3-081075			Interworking of Incoming Calls from IMS	020	030
4/7/08	CT3#48bis	C3-081076			Interworking of Outgoing Calls towards IMS	020	030
4/7/08	CT3#48bis	C3-081077			Incoming Call Flows from IMS	020	030
4/7/08	CT3#48bis	C3-080913			Outgoing Call Flows towards IMS	020	030
4/7/08	CT3#48bis	C3-081079			DTMF interworking procedures in SIP-I based Nc	020	030
4/7/08	CT3#48bis	C3-081207			ISUP Interworking Procedures	020	030
4/7/08	CT3#48bis	C3-081242			User Plane Interworking	020	030
4/7/08	CT3#48bis	C3-081080			Stage 2 aspects for CS-IBCF and CS-TrGW	020	030
27/8/08	CT3#49	C3-081661			Call Clearing when interworking with IMS	030	040
27/8/08	CT3#49	C3-081541			Codec negotiation when interworking with IMS and with external SIP-I networks	030	040
27/8/08	CT3#49	C3-081542			MGW Selection Procedures	030	040
27/8/08	CT3#49	C3-081543			Updating precondition information when local preconditions are met	030	040
27/8/08	CT3#49	C3-081544			Generation of ringing tone when interworking with IMS	030	040
27/8/08	CT3#49	C3-081545			Clarification of sending received SIP messages to the other side	030	040
27/8/08	CT3#49	C3-081548			Alignment of Preconditions with TS 29.231	030	040
27/8/08	CT3#49	C3-081549			Supplementary Service Interworking with IMS	030	040
27/8/08	CT3#49	C3-081550			DTMF Interworking towards IMS	030	040
27/8/08	CT3#49	C3-081497			Interworking to BICC networks	030	040
27/8/08	CT3#49	C3-081663			Terminology O-IWU and I-IWU	030	040
27/8/08	CT3#49	C3-081498			Interworking specification between SIP-I and IMS shall stay in TS 29.235	030	040
27/8/08	CT3#49	C3-081592			Border Control Architecture	030	040
01/9/08	CT3#49				Version 2.0.0 created for presentation to TSG by MCC	040	200
16/9/08	TSG#41				Version 8.0.0 created by MCC	200	800
11/12/08	TSG#42	CP-080754	001	1	Interworking between SIP-I based CS and IMS when forking occurs	800	810
11/12/08	TSG#42	CP-080754	002	1	Update on MGW bypass	800	810
11/12/08	TSG#42	CP-080754	003	1	Incorrect rejection of INVITE request when ALLOW header does not contain UPDATE.	800	810
11/12/08	TSG#42	CP-080754	004	3	Miscellaneous clean-ups	800	810
11/12/08	TSG#42	CP-080765	005	2	CS-IBCF procedures as an exit and entry point	800	810
11/12/08	TSG#42	CP-080765	006	4	CS-IBCF – CS-TrGW Interaction Procedures	800	810
11/12/08	TSG#42	CP-080754	012	1	Service Interworking between SIP-I on Nc and IMS	800	810
11/12/08	TSG#42	CP-080754	013	1	Corrections and improvements in wording	800	810
11/12/08	TSG#42	CP-080754	014		Minor editorial corrections	800	810
11/12/08	TSG#42	CP-080754	015	2	Removal of editor notes in chapter specifying interworking with external SIP-I networks	800	810
11/12/08	TSG#42	CP-080754	016	3	Removal of some editor notes in chapter specifying interworking with IMS	800	810
11/12/08	TSG#42	CP-080754	018		Signaling of the MGW Identifier	800	810
11/12/08	TSG#42	CP-080754	019	5	Call release from external SIP-I network without encapsulated ISUP REL	800	810
11/12/08	TSG#42	CP-080754	020	1	Interworking with overlap signalling in IMS	800	810
11/12/08	TSG#42	CP-080765	021	2	CS-IBCF procedures	800	810
03/2009	TSG#43	CP-090092	023	2	CS-Ix – Minor corrections	810	820
03/2009	TSG#43	CP-090092	024	2	CS-Ix Update proposal for clause A.4	810	820
03/2009	TSG#43	CP-090092	028	2	Clean-up of Annex A	810	820
03/2009	TSG#43	CP-090080	030	2	Receipt of Re-Invite with no SDP	810	820
03/2009	TSG#43	CP-090080	031	2	B2BUA: setting of SIP header values when interworking with IMS	810	820
03/2009	TSG#43	CP-090080	032	1	Supplementary Service Interworking with IMS	810	820
03/2009	TSG#43	CP-090080	033	3	Exception to message transiting when interworking failure response	810	820
03/2009	TSG#43	CP-090097	034	4	Ix procedures	820	900
05/2009	TSG#44	CP-090335	037	2	Codec negotiation when interworking with BICC based network	900	910
05/2009	TSG#44	CP-090351	038	2	Stage 2 requirements / use cases for CS-IBCF / CS-TrGW	900	910
09/2009	TSG#45	CP-090581	040	1	Addition of Release TrGW Termination to CS-IBCF procedures	910	920
09/2009	TSG#45	CP-090581	041		Minor correction to A.7.1.2.2.5	910	920
09/2009	TSG#45	CP-090581	042	2	Addition of IP Interface Type to CS-IBCF procedures	910	920
09/2009	TSG#45	CP-090570	045		Text relates to wrong call direction	910	920
09/2009	TSG#45	CP-090570	047		Text relates to wrong message direction	910	920
09/2009	TSG#45	CP-090581	050	2	Notification of released bearer	910	920
09/2009	TSG#45	CP-090581	051		Remote Resources in responses optional	910	920
12/2009	TSG#46	CP-090839	054		Handling of a MGW identifier from external SIP-I network	920	930
12/2009	TSG#46	CP-090850	055	3	Media Inactivity Detection	920	930
12/2009	TSG#46	CP-090850	059	3	RTCP Handling	920	930
12/2009	TSG#46	CP-090850	061	1	QoS Packet Marking	920	930
12/2009	TSG#46	CP-090850	063	3	Termination Heartbeat Procedure	920	930

12/2009	TSG#46	CP-090850	065	3	Mandatory Features in the CS-TrGW	920	930
12/2009	TSG#46	CP-090850	066		Non-Call Related Procedure Alignment	920	930
12/2009	TSG#46	CP-090850	067	2	Traffic Policing	920	930
12/2009	TSG#46	CP-090858	068	1	Reference Tidy-Up	920	930
12/2009	TSG#46	CP-090858	069	1	Miscellaneous Corrections	920	930
03/2010	TSG#47	CP-100091	071	1	Abbreviations Tidy-Up	930	940
03/2010	TSG#47	CP-100085	072		Use of IP Interface Type	930	940
03/2010	TSG#47	CP-100083	074	1	Global Text Telephony Interworking between IMS and SIP-I on NC based CN	930	940
03/2010	TSG#47	CP-100084	075	1	Mn Procedures when interworking between IMS and SIP-I on NC based CN	930	940
06/2010	TSG#48	CP-100316	076	2	Handling of Stream mode	940	950
06/2010	TSG#48	CP-100316	077		RTCP handling correction	940	950
06/2010	TSG#48	CP-100316	078	1	Resolution of editors notes	940	950
09/2010	TSG#49	CP-100550	079	1	Local IP Resources IE: changing of property	950	960
09/2010	TSG#49	CP-100557	080		Correcting unspecific external reference	950	960
09/2010	TSG#49	CP-100550	081	1	Procedures for Emergency indicator	950	960
03/2011	TSG#51	CP-110112	084		Adding CS-lx functionalities to Mc-profile	960	970
03/2011	TSG#51	CP-110126	085	2	Add the function of Interworking for supplementary service CAT	970	1000
06/2012	TSG#56	CP-120338	091	1	Forking and SDP offer-answer Interworking corrections	1000	1010
09/2012	TSG#57				Automatic upgrade from previous Release version 10.1.0	1010	1100
12/2012	TSG#58	CP-120843	092	1	100 Trying not interworked between IMS and SIP-I based CS CN	1100	1110
06/2013	TSG#60	CP-130317	096	1	MGCF behavior clarification	1110	1120
09/2013	TSG#61	CP-130541	100	1	INVITE without SDP	1120	1130