

3GPP TS 29.119 V11.0.0 (2012-09)

Technical Specification

3rd Generation Partnership Project; Technical Specification Group Core Network and Terminals; GPRS Tunnelling Protocol (GTP) specification for Gateway Location Register (GLR) (Release 11)



The present document has been developed within the 3rd Generation Partnership Project (3GPPTM) and may be further elaborated for the purposes of 3GPP.

The present document has not been subject to any approval process by the 3GPP Organisational Partners and shall not be implemented.

This Specification is provided for future development work within 3GPP only. The Organisational Partners accept no liability for any use of this Specification.

Specifications and reports for implementation of the 3GPPTM system should be obtained via the 3GPP Organisational Partners' Publications Offices.

Keywords

LTE, UMTS, network, GPRS, GTP

3GPP

Postal address

3GPP support office address

650 Route des Lucioles - Sophia Antipolis
Valbonne - FRANCE
Tel.: +33 4 92 94 42 00 Fax: +33 4 93 65 47 16

Internet

<http://www.3gpp.org>

Copyright Notification

No part may be reproduced except as authorized by written permission.
The copyright and the foregoing restriction extend to reproduction in all media.

© 2012, 3GPP Organizational Partners (ARIB, ATIS, CCSA, ETSI, TTA, TTC).
All rights reserved.

UMTS™ is a Trade Mark of ETSI registered for the benefit of its members

3GPP™ is a Trade Mark of ETSI registered for the benefit of its Members and of the 3GPP Organizational Partners

LTE™ is a Trade Mark of ETSI currently being registered for the benefit of its Members and of the 3GPP Organizational Partners
GSM® and the GSM logo are registered and owned by the GSM Association

Contents

Foreword	4
1 Scope	5
1.1 References	5
2 Definitions and abbreviations	5
2.1 Definitions	5
2.2 Abbreviations	6
3 General	6
4 Transmission order and bit definitions	7
5 GTP header	7
6 GTP Message and Message Formats	7
6.1 Signalling Message Formats	7
6.2 Path Management messages	8
6.3 Tunnel Management messages	8
6.4 Location Management message	9
6.5 Mobility Management messages	9
6.6 Reliable delivery of signalling messages	9
6.7 Information element	10
7 Signalling Plane (GTP-C)	10
8 GTP-U	10
9 Path Protocol	10
10 Error handling	10
11 Inter-PLMN GTP communication over the Gp Interface	10
12 IP, the networking technology used by GTP	10
13 GTP parameters	10
Annex A (informative): Change history	11

Foreword

The present document has been produced by the 3rd Generation Partnership Project (3GPP).

The contents of the present document are subject to continuing work within the TSG and may change following formal TSG approval. Should the TSG modify the contents of the present document, it will be re-released by the TSG with an identifying change of release date and an increase in version number as follows:

Version x.y.z

where:

- x the first digit:
 - 1 presented to TSG for information;
 - 2 presented to TSG for approval;
 - 3 or greater indicates TSG approved document under change control.
- y the second digit is incremented for all changes of substance, i.e. technical enhancements, corrections, updates, etc.
- z the third digit is incremented when editorial only changes have been incorporated in the document.

1 Scope

The present document describes the signalling requirements and procedures used at network elements related to the GLR for GTP within the 3GPP system at the application level.

The present document gives the description of the systems needed only in the network utilising GLR as the delta document against 3GPP TS 29.060.

1.1 References

The following documents contain provisions which, through reference in this text, constitute provisions of the present document.

- References are either specific (identified by date of publication, edition number, version number, etc.) or non-specific.
- For a specific reference, subsequent revisions do not apply.
- For a non-specific reference, the latest version applies. In the case of a reference to a 3GPP document (including a GSM document), a non-specific reference implicitly refers to the latest version of that document *in the same Release as the present document*.

- [1] 3GPP TS 23.060: "General Packet Radio Service (GPRS); Service description Stage2".
- [2] 3GPP TS 23.119: "Gateway Location Register (GLR) – stage2".
- [3] 3GPP TS 24.008: "Mobile radio interface layer 3 specification, Core Network Protocols – Stage 3".
- [4] 3GPP TS 29.002: "Mobile Application Part (MAP) specification".
- [5] 3GPP TS 29.060: "General Packet Radio Service (GPRS); GPRS Tunnelling Protocol (GTP) across the Gn and Gp Interface".

2 Definitions and abbreviations

2.1 Definitions

For the purposes of the present document, the following terms and definitions apply.

Gateway Location Register: this entity handles location management of roaming subscriber in visited network without involving HLR

Intermediate GSN: this entity is used as serving GSN towards home network and relay some PDU notification messages between serving GSN and Gateway GSN

MM context: information sets held in MS and GSNs for a GPRS subscriber related to mobility management (MM)

MM Context ID: IMSI or equivalent for use in conjunction with Anonymous Access (please refer to section GTP Header)

Path: UDP/IP path and TCP/IP path are examples of paths that may be used to multiplex GTP tunnels

Path Protocol: path Protocol is the protocol(s) used as a bearer of GTP between GSNs

PDP: packet Data Protocol (PDP) is a network protocol used by an external packet data network interfacing to GPRS

PDP Context:	information sets held in MS and GSNs for a PDP address
Signalling message:	GTP signalling messages are exchanged between GSN pairs in a path. The signalling messages are used to transfer GSN capability information between GSN pairs and to create, update and delete GTP tunnels
T-PDU:	original packet, for example an IP datagram, from an MS or a network node in an external packet data network. A T-PDU is the payload that is tunnelled in the GTP tunnel
Tunnel Endpoint Identifier (TEID):	this field unambiguously identifies a tunnel endpoint in the receiving GTP-U or GTP-C protocol entity. The receiving end side of a GTP tunnel locally assigns the TEID value the transmitting side has to use. The TEID values are exchanged between tunnel endpoints using GTP-C messages

2.2 Abbreviations

For the purposes of the present document, the following abbreviations apply:

GGSN	Gateway GPRS support node
GLR	Gateway Location Register
GPRS	General Packet Radio Service
GTP	GPRS Tunnelling Protocol
IM_GSN	Intermediate GSN
IP	Internet Protocol
GLR	Gateway Location Register
SGSN	Serving GPRS support node
TEID	Tunnel Endpoint Identifier
UDP	User Datagram Protocol

3 General

The present document defines the GPRS Tunnelling Protocol (GTP) specific to the network with the GLR, i.e. the protocol between IM_GSN and other nodes (i.e. GGSN, SGSN and GTP-MAP protocol converting GSN). It includes only the GTP signalling but not data transfer procedures.

The interface between IM_GSM and GGSN is either intra-PLMN interface or inter-PLMN interface.

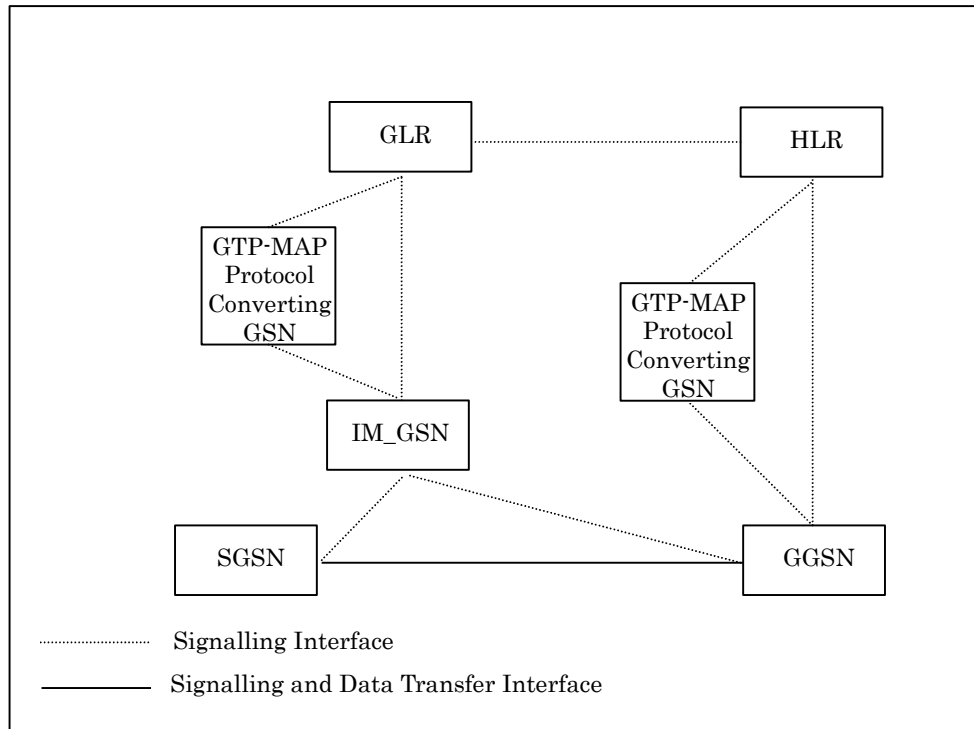

Figure 1: Logical Architecture for PS domain in the network with GLR

The GTP protocol is implemented only by IM_GSNs, SGSNs and GGSNs. No other systems need to be aware of GTP. GPRS MSs are connected to a SGSN without being aware of GTP.

It is assumed that there will be a many-to-many relationship between IM_GSNs, SGSNs and GGSNs. An IM_GSN may provide service to many GGSNs. A SGSN may provide service to many IM_GSNs and GGSNs.

4 Transmission order and bit definitions

Transmission order and bit definitions on the interface between the IM_GSN and other nodes in the network with GLR are the same as that used in the network without the GLR, see 3GPP TS 29.060.

5 GTP header

The GTP header used on interface between the IM_GSN and other nodes in the network with GLR is the same as that used in the network without the GLR, see 3GPP TS 29.060.

6 GTP Message and Message Formats

The only signalling plane exists between the IM_GSN and other nodes (i.e. GGSN, SGSN and GTP-MAP protocol converting GSN).

6.1 Signalling Message Formats

GTP defines a set of signalling messages between two associated GSNs. The signalling messages to be used between the IM_GSN and other nodes are defined in the table below. For the GTP signalling messages to be used on other interfaces see 3GPP TS 29.060.

Table 1: Signalling messages

Message Type value (Decimal)	Signalling message	Reference
3	Version Not Supported	7.4.3 in 3GPP TS 29.060
27	PDU Notification Request	7.5.12 in 3GPP TS 29.060
28	PDU Notification Response	7.5.13 in 3GPP TS 29.060
29	PDU Notification Reject Request	7.5.14 in 3GPP TS 29.060
30	PDU Notification Reject Response	7.5.15 in 3GPP TS 29.060
32	Send Routing Information for GPRS Request	7.6.1 in 3GPP TS 29.060
33	Send Routing Information for GPRS Response	7.6.2 in 3GPP TS 29.060
34	Failure Report Request	7.6.3 in 3GPP TS 29.060
35	Failure Report Response	7.6.4 in 3GPP TS 29.060

6.2 Path Management messages

The messages, which are listed in following table, are used on the interface between the IM_GSN and other nodes. For the definitions of these messages and other messages used on the other interfaces refer to the corresponding sections in 3GPP TS 29.060.

Messages	Sending node	Receiving node
Version Not Supported	IM_GSN	GGSN, SGSN
	GGSN, SGSN	IM_GSN

6.3 Tunnel Management messages

In following table, only the messages used between the IM_GSN and GGSN and between the IM_GSN and SGSN are listed. For the definitions of these messages and other messages used on the other interfaces refer to the corresponding sections in 3GPP TS 29.060.

Messages	Sending node	Receiving node
PDU Notification Request	GGSN	IM_GSN
	IM_GSN	SGSN
PDU Notification Response	SGSN	IM_GSN
	IM_GSN	GGSN
PDU Notification Reject Request	SGSN	IM_GSN
	IM_GSN	GGSN
PDU Notification Reject Response	GGSN	IM_GSN
	IM_GSN	SGSN

6.4 Location Management message

In the network with the GLR, The optional Location Management messages are defined to support the case when Network-Requested PDP Context Activation procedures are used and an IM_GSN does not have a SS7 MAP interface. GTP is then used to transfer signalling messages between the IM_GSN and a GTP-MAP protocol-converting GSN in the GPRS backbone network. The GTP-MAP protocol-converting GSN converts the signalling messages described in this section between GTP and MAP. The MAP messages are sent to and received from the GLR. The GTP-MAP protocol-converting function is described in 3GPP TS 23.060. The MAP protocol describing the corresponding procedures and messages is described in 3GPP TS 29.002. This alternative method is illustrated in Figure 2.

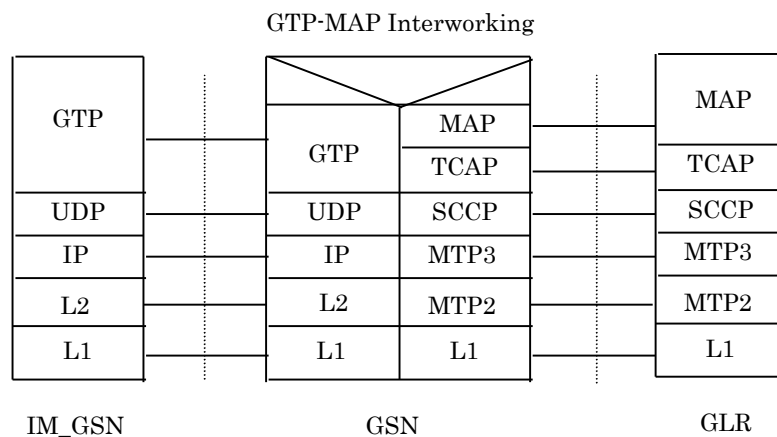

Figure 2: IM_GSN - GLR Signalling via a GTP-MAP protocol-converter in a GSN

In following table, only the messages used between the IM_GSN and The GTP-MAP protocol-converting GSN are listed. For the definitions of these messages and other messages used on the other interfaces refer to the corresponding sections in 3GPP TS 29.060.

Messages	Sending node	Receiving node
Send Routing Information for GPRS Request	IM_GSN	GTP-MAP protocol-converting
Send Routing Information for GPRS Response	GTP-MAP protocol-converting	IM_GSN
Failure Report Request	IM_GSN	GTP-MAP protocol-converting
Failure Report Response	GTP-MAP protocol-converting	IM_GSN

6.5 Mobility Management messages

The messages belonging to the mobility management messages are not used on the interface between the IM_GSN and other nodes in the network with the GLR.

6.6 Reliable delivery of signalling messages

For the Reliability mechanism in the IM_GSN, see section 7.8 in 3GPP TS 29.060.

6.7 Information element

The format of information elements in the message used on the interface between the IM_GSN and other nodes in the network with GLR is the same as that in the network without the GLR. See 3GPP TS 29.060.

7 Signalling Plane (GTP-C)

The definition of signalling plane used in the network with the GLR is the same as that used in the network without the GLR, see in 3GPP TS 29.060.

8 GTP-U

GTP-U is not used on the interface between the IM_GSN and other nodes. For the definition of GTP-U on the other interfaces, see in 3GPP TS 29.060.

9 Path Protocol

The Path Protocol on the interface between the IM_GSN and other nodes in the network with the GLR is the same as that used in the network without the GLR. See 3GPP TS 29.060.

10 Error handling

The error handling on the interface between the IM_GSN and other nodes is the same as that in the network without the GLR. See 3GPP TS 29.060. One exception is that the IM_GSN doesn't have a Restart Counter because the IM_GSM stores no PDP and MM context and therefore the synchronisation of the status of these with other GSNs is not needed.

11 Inter-PLMN GTP communication over the Gp Interface

Refer to the corresponding section in 3GPP TS 29.060.

12 IP, the networking technology used by GTP

Refer to the corresponding section in 3GPP TS 29.060.

13 GTP parameters

The definitions and directions for use of the parameters in GTP (inc. timer values or counter values and so on) on the interface between the IM_GSN and other nodes is the same as that used in the network without the GLR. See 3GPP TS 29.060.

Annex A (informative): Change history

Document history		
V0.0.1	Oct 1999	The GTP protocol part is separated from MAP protocol part, and new specification related to GTP issue is generated.
V0.1.0	Nov 1999	For approval by N2#8
V1.0.0	Dec 1999	For information and approval by TSG CN#6.
V1.0.1	Jan 2000	Only editorial modifications including some alignment with 29.060
V2.0.0	Mar 2000	Submitted for approval to TSG CN#07
V3.0.0	Mar 2000	Approved by TSG CN#07
V4.0.0	Mar 2001	Approved by TSG CN#11
V5.0.0	Jun 2002	Rel-5 created after CN#16
V6.0.0	Dec 2004	Rel-6 created after CN#26
V7.0.0	June 2007	Upgraded unchanged from Rel-6 after CT#36
V8.0.0	Dec 2008	Upgraded unchanged from Rel-7 after CT#42
V9.0.0	Dec 2009	Update to Rel-9 version (MCC)
V10.0.0	Mar 2011	Update to Rel-10 version (MCC)
V11.0.0	Sep 2012	Update to Rel-11 version (MCC)