

3GPP TS 26.101 V11.0.0 (2012-09)

Technical Specification

**3rd Generation Partnership Project;
Technical Specification Group Services and System Aspects;
Mandatory speech codec speech processing functions;
Adaptive Multi-Rate (AMR) speech codec frame structure
(Release 11)**



The present document has been developed within the 3rd Generation Partnership Project (3GPP™) and may be further elaborated for the purposes of 3GPP. The present document has not been subject to any approval process by the 3GPP Organizational Partners and shall not be implemented. This Specification is provided for future development work within 3GPP only. The Organizational Partners accept no liability for any use of this Specification. Specifications and reports for implementation of the 3GPP™ system should be obtained via the 3GPP Organizational Partners' Publications Offices.

Keywords

GSM, UMTS, codec, AMR, LTE

3GPP

Postal address

3GPP support office address

650 Route des Lucioles - Sophia Antipolis
Valbonne - FRANCE
Tel.: +33 4 92 94 42 00 Fax: +33 4 93 65 47 16

Internet

<http://www.3gpp.org>

Copyright Notification

No part may be reproduced except as authorized by written permission.
The copyright and the foregoing restriction extend to reproduction in all media.

© 2012, 3GPP Organizational Partners (ARIB, ATIS, CCSA, ETSI, TTA, TTC).
All rights reserved.

UMTS™ is a Trade Mark of ETSI registered for the benefit of its members
3GPP™ is a Trade Mark of ETSI registered for the benefit of its Members and of the 3GPP Organizational Partners
LTE™ is a Trade Mark of ETSI currently being registered for the benefit of its Members and of the 3GPP Organizational Partners
GSM® and the GSM logo are registered and owned by the GSM Association

Contents

Foreword	4
1 Scope	5
2 References.....	5
3 Definitions and Abbreviations	5
3.1 Definitions	5
3.2 Abbreviations	5
4 AMR codec frame format (AMR IF1)	6
4.1 AMR Header and AMR Auxiliary Information	6
4.1.1 Frame Type, Mode Indication, and Mode Request	6
4.1.2 Frame Quality Indicator	7
4.1.3 Mapping to TX_TYPE and RX_TYPE	7
4.1.4 Codec CRC.....	8
4.2 AMR Core Frame	8
4.2.1 AMR Core Frame with speech bits: Bit ordering	8
4.2.2 AMR Core Frame with speech bits: Class division	9
4.2.3 AMR Core Frame with comfort noise bits	9
4.3 AMR frame composition.....	10
4.4 GSM-EFR Frame Composition	11
4.4.1 GSM-EFR Frame with speech bits	12
4.4.2 GSM-EFR Frame with comfort noise bits	12
Annex A (informative): AMR Interface Format 2 (with octet alignment).....	13
Annex B (normative): Tables for AMR Core Frame bit ordering	17
Annex C (informative): Change history.....	20

Foreword

This Technical Specification has been produced by the 3rd Generation Partnership Project (3GPP).

The contents of the present document are subject to continuing work within the TSG and may change following formal TSG approval. Should the TSG modify the contents of the present document, it will be re-released by the TSG with an identifying change of release date and an increase in version number as follows:

Version x.y.z

where:

- x the first digit:
 - 1 presented to TSG for information;
 - 2 presented to TSG for approval;
 - 3 or greater indicates TSG approved document under change control.
- y the second digit is incremented for all changes of substance, i.e. technical enhancements, corrections, updates, etc.
- z the third digit is incremented when editorial only changes have been incorporated in the document.

1 Scope

The present document describes a generic frame format for the Adaptive Multi-Rate (AMR) speech codec and the Enhanced Full Rate (GSM-EFR) speech codec. This format shall be used as a common reference point when interfacing speech frames between different elements of the 3G system and between different systems. Appropriate mappings to and from this generic frame format will be used within and between each system element.

Annex A describes a second frame format which shall be used when octet alignment of AMR frames is required.

2 References

The following documents contain provisions which, through reference in this text, constitute provisions of the present document.

- References are either specific (identified by date of publication, edition number, version number, etc.) or non-specific.
- For a specific reference, subsequent revisions do not apply.
- For a non-specific reference, the latest version applies. In the case of a reference to a 3GPP document (including a GSM document), a non-specific reference implicitly refers to the latest version of that document *in the same Release as the present document*.

- [1] TS 26.090: "AMR Speech Codec; Speech Transcoding Functions".
- [2] TS 26.093: "AMR Speech Codec; Source Controlled Rate Operation".
- [3] TS 26.092: "AMR Speech Codec; Comfort Noise Aspects".
- [4] TS 46.060: "EFR Speech Codec; Speech Transcoding Functions".
- [5] TS 46.062: "EFR Speech Codec; Comfort Noise Aspects".

3 Definitions and Abbreviations

3.1 Definitions

For the purposes of the present document, the following terms and definitions apply:

AMR mode: one of the eight AMR codec bit-rates denoted also with indices 0 to 7 where 0 maps to the 4.75 kbit/s mode and 7 maps to the 12.2 kbit/s mode.

AMR codec mode: same as AMR mode.

RX_TYPE: classification of the received frame as defined in [2].

TX_TYPE: classification of the transmitted frame as defined in [2].

3.2 Abbreviations

For the purposes of the present document, the following abbreviations apply:

CRC	Cyclic Redundancy Check
FQI	Frame Quality Indicator
GSM	Global System for Mobile communication
LSB	Least Significant Bit

MSB	Most Significant Bit
RX	Receive
PDC	Personal Digital Communication (ARIB standard)
SCR	Source Controlled Rate operation
SID	Silence Descriptor (Comfort Noise Frame)
TDMA	Time Division Multiple Access (IS-641)
TX	Transmit

4 AMR codec frame format (AMR IF1)

This clause describes the generic frame format for both the speech and comfort noise frames of the AMR speech codec. This format is referred to as AMR Interface Format 1 (AMR IF1). Annex A describes AMR Interface Format 2 (AMR IF2).

Each AMR codec mode follows the generic frame structure depicted in figure 1. The frame is divided into three parts: AMR Header, AMR Auxiliary Information, and AMR Core Frame. The AMR Header part includes the Frame Type and the Frame Quality Indicator fields. The AMR auxiliary information part includes the Mode Indication, Mode Request, and Codec CRC fields. The AMR Core Frame part consists of the speech parameter bits or, in case of a comfort noise frame, the comfort noise parameter bits. In case of a comfort noise frame, the comfort noise parameters replace Class A bits of AMR Core Frame while Class B and C bits are omitted.

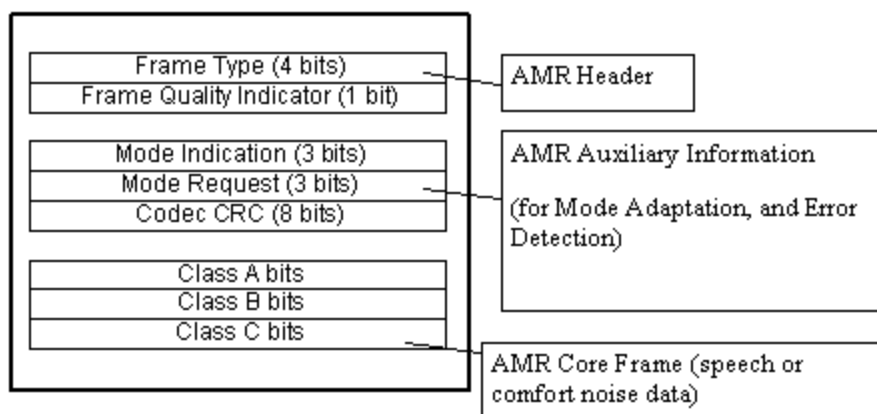

Figure 1: Generic AMR frame structure

4.1 AMR Header and AMR Auxiliary Information

This subclause describes the AMR Header of figure 1.

4.1.1 Frame Type, Mode Indication, and Mode Request

Table 1a defines the 4-bit Frame Type field. Frame Type can indicate the use of one of the eight AMR codec modes, one of four different comfort noise frames, or an empty frame. In addition, three Frame Type Indices are reserved for future use. The same table is reused for the Mode Indication and Mode Request fields which are 3-bit fields each and are defined only in the range 0...7 to specify one of the eight AMR codec modes.

Table 1a: Interpretation of Frame Type, Mode Indication and Mode Request fields

Frame Type	Mode Indication	Mode Request	Frame content (AMR mode, comfort noise, or other)
0	0	0	AMR 4,75 kbit/s
1	1	1	AMR 5,15 kbit/s
2	2	2	AMR 5,90 kbit/s
3	3	3	AMR 6,70 kbit/s (PDC-EFR)
4	4	4	AMR 7,40 kbit/s (TDMA-EFR)
5	5	5	AMR 7,95 kbit/s
6	6	6	AMR 10,2 kbit/s
7	7	7	AMR 12,2 kbit/s (GSM-EFR)
8	-	-	AMR SID
9	-	-	GSM-EFR SID
10	-	-	TDMA-EFR SID
11	-	-	PDC-EFR SID
12-14	-	-	For future use
15	-	-	No Data (No transmission/No reception)

4.1.2 Frame Quality Indicator

The content of the Frame Quality Indicator field is defined in Table 1b. The field length is one bit. The Frame Quality Indicator indicates whether the data in the frame contains errors.

Table 1b: Definition of Frame Quality Indicator

Frame Quality Indicator (FQI)	Quality of data
0	Bad frame or Corrupted frame (bits may be used to assist error concealment)
1	Good frame

4.1.3 Mapping to TX_TYPE and RX_TYPE

Table 1c shows how the AMR Header data (FQI and Frame Type) maps to the TX_TYPE and RX_TYPE frames defined in [2].

Table 1c: Mapping of Frame Quality Indicator and Frame Type to TX_TYPE and RX_TYPE [2], respectively

Frame Quality Indicator	Frame Type Index	TX_TYPE or RX_TYPE	Comment
1	0-7	SPEECH_GOOD	The specific Frame Type Index depends on the bit-rate being used.
0	0-7	SPEECH_BAD	The specific Frame Type Index depends on the bit-rate being used. The corrupted data may be used to assist error concealment.
1	8	SID_FIRST or SID_UPDATE	For AMR: SID_FIRST and SID_UPDATE are differentiated using one Class A bit: STI.
0	8	SID_BAD	For AMR
1	9	GSM-EFR SID	For GSM-EFR
0	9	GSM-EFR SID_BAD	For GSM-EFR
1	10-11	SID_UPDATE	For TDMA-EFR and PDC-EFR
0	10-11	SID_BAD	For TDMA-EFR and PDC-EFR
1	15	NO_DATA	Typically a non-transmitted frame or an erased or stolen frame with no data usable to assist error concealment.

4.1.4 Codec CRC

Generic AMR codec frames with Frame Type 0.11 are associated with an 8-bit CRC for error-detection purposes. The Codec CRC field of AMR Auxiliary Information in figure 1 contains the value of this CRC. These eight parity bits are generated by the cyclic generator polynomial:

$$- G(x)=D^8 + D^6 + D^5 + D^4 + 1$$

which is computed over all Class A bits of AMR Core Frame. Class A bits for Frame Types 0.7 are defined in subclause 4.2.2 (for speech bits) and for Frame Types 8.11 in subclause 4.2.3 (for comfort noise bits).

When Frame Type Index of table 1a is 15 the CRC field is not included in the Generic AMR frame.

4.2 AMR Core Frame

This subclause contains the description of AMR Core Frame of figure 1. The descriptions for AMR Core Frame with speech bits and with comfort noise bit are given separately.

4.2.1 AMR Core Frame with speech bits: Bit ordering

This subclause describes how AMR Core Frame carries the coded speech data. The bits produced by the speech encoder are denoted as $\{s(1),s(2),\dots,s(K)\}$, where K refers to the number of bits produced by the speech encoder as shown in table 2. The notation $s(i)$ follows that of [1]. The speech encoder output bits are ordered according to their subjective importance. This bit ordering can be utilized for error protection purposes when the speech data is, for example, carried over a radio interface. Tables B.1 to B.8 in Annex B define the AMR IF1 bit ordering for all the eight AMR codec modes. In these tables the speech bits are numbered in the order they are produced by the corresponding speech encoder as described in the relevant tables of TS 26.090 [1]. The reordered bits are denoted below, in the order of decreasing importance, as $\{d(0),d(1),\dots,d(K-1)\}$.

The ordering algorithm is described in pseudo code as:

- for $j = 0$ to $K-1$
- $d(j) := s(\text{table}_m(j)+1)$;

where $\text{table}_m(j)$ refers to the relevant table in Annex B depending on the AMR mode $m=0..7$. The Annex B tables should be read line by line from left to right. The first element of the table has the index 0.

4.2.2 AMR Core Frame with speech bits: Class division

The reordered bits are further divided into three indicative classes according to their subjective importance. This class division is only informative and provides supporting information for mapping this generic format into specific formats. The three different importance classes can then be subject to different error protection in the network.

The importance classes are Class A, Class B, and Class C. Class A contains the bits most sensitive to errors and any error in these bits typically results in a corrupted speech frame which should not be decoded without applying appropriate error concealment. This class is protected by the Codec CRC in AMR Auxiliary Information. Classes B and C contain bits where increasing error rates gradually reduce the speech quality, but decoding of an erroneous speech frame is usually possible without annoying artefacts. Class B bits are more sensitive to errors than Class C bits. The importance ordering applies also within the three different classes and there are no significant step-wise changes in subjective importance between neighbouring bits at the class borders.

The number of speech bits in each class (Class A, Class B, and Class C) for each AMR mode is shown in table 2. The classification in table 2 and the importance ordering $d(j)$, together, are sufficient to assign all speech bits to their correct classes. For example, when the AMR codec mode is 4.75, then the Class A bits are $d(0)..d(41)$, Class B bits are $d(42)..d(94)$, and there are no Class C bits.

Table 2: Number of bits in Classes A, B, and C for each AMR codec mode

Frame Type	AMR codec mode	Total number of bits	Class A	Class B	Class C
0	4,75	95	42	53	0
1	5,15	103	49	54	0
2	5,90	118	55	63	0
3	6,70	134	58	76	0
4	7,40	148	61	87	0
5	7,95	159	75	84	0
6	10,2	204	65	99	40
7	12,2	244	81	103	60

4.2.3 AMR Core Frame with comfort noise bits

The AMR Core Frame content for the additional frame type with Frame Type Index 8 in table 1a is described in this subclause. This consists of the frame related to Source Controlled Rate Operation specified in [2].

The data content (comfort noise bits) of the additional frame types is carried in AMR Core Frame. The comfort noise bits are all mapped to Class A of AMR Core Frame and Classes B and C are not used. This is a notation convention only and the class division has no meaning for comfort noise bits.

The number of bits in each class (Class A, Class B, and Class C) for the AMR comfort noise bits (Frame Type Index 8) is shown in table 3. The contents of SID_UPDATE and SID_FIRST are divided into three parts (SID Type Indicator (STI), Mode Indication ($mi(i)$), and Comfort Noise Parameters ($s(i)$) as defined in [2]. In case of SID_FIRST the Comfort Noise Parameters bits ($s(i)$) shall be set to "0".

The comfort noise parameter bits produced by the AMR speech encoder are denoted as $s(i) = \{s(1), s(2), \dots, s(35)\}$. The notation $s(i)$ follows that of [3]. These bits are numbered in the order they are produced by the AMR encoder without any reordering. These bits are followed by the SID Type Indicator **STI** and the Mode Indication $mi(i) = \{mi(0), mi(1), mi(2)\} = \{LSB .. MSB\}$. Thus, the AMR SID or comfort noise bits $\{d(0), d(1), \dots, d(38)\}$ are formed as defined by the pseudo code below.

- for $j = 0$ to 34;
- $d(j) := s(j+1)$;
- $d(35) := \mathbf{STI}$;
- for $j = 36$ to 38;
- $d(j) := mi(j-36)$. Note: This mapping is different to the usual mapping: LSB first.

Note: The alternative would be: $d(j) := mi(38-j)$: MSB first.

Table 3. Bit classification for Frame Type 8 (AMR SID)

Frame Type Index	FQI	AMR TX_TYPE or RX_TYPE	Total number of bits	Class A			Class B	Class C
				SID Type Indicator (STI)	Mode Indication mi(i)	Comfort Noise Parameters(i)		
8	1	SID_UPDATE	39	1 (= "1")	3	35	0	0
8	1	SID_FIRST	39	1 (= "0")	3	35 (= "0")	0	0
8	0	SID_BAD	39	1	3	35	0	0

The number of bits in each class (Class A, Class B, and Class C) for the comfort noise bits of Frame Types 9-11 is shown in Table 7.

Table 4: void

4.3 AMR frame composition

The generic AMR frame is formed as a concatenation of AMR Header, AMR Auxiliary Information and the AMR Core Frame, in this order. The MSB of the Frame Type is placed in bit 8 of the first octet (see example in table 5 below), the LSB of the Frame Type is placed in bit 5. Then the next parameter follows, which is the Frame Quality Indicator, and so on. Between Mode Request and Codec CRC five spare bits are inserted to align the Codec CRC and the AMR Core frame to the octet boundary. The first bit of the AMR Core frame $d(0)$ is placed in bit 8 of octet 4. The last bit of the generic AMR frame is the last bit of AMR Core Frame, which is the last bit of speech bits or the last bit of comfort noise bits, as defined in subclauses 4.2.1 and 4.2.3. Table 5 shows the composition for the example of the Codec Mode 6.7 kbit/s and table 6 shows the composition for the AMR SID frame.

Table 5: Mapping of an AMR speech coding mode into the generic AMR frame, AMR IF1, example: AMR 6.7 kbit/s, "good frame", Mode Request = 1.

Octet	Mapping of bits AMR 6.7							LSB bit 1
	MSB bit 8	bit 7	bit 6	bit 5	bit 4	bit 3	bit 2	
1	Frame Type (=3)			FQI			Mode Indication (=3)	
	0	0	1	1	1	0	1	1
2	Mode Request (=1)			spare				
	0	0	1	0	0	0	0	0
3	Codec CRC							
	CRC(7)	CRC(6)	CRC(5)	CRC(4)	CRC(3)	CRC(2)	CRC(1)	CRC(0)
4	AMR Core Frame (octet 1)							
	d(0)	d(1)	d(2)	d(3)	d(4)	d(5)	d(6)	d(7)
5..19								
20	AMR Core Frame (octet 17)						undefined	
	d(128)	d(129)	d(130)	d(131)	d(132)	d(133)		

Table 6: Mapping of an AMR SID frame into the generic AMR frame, AMR IF1, example: AMR SID_Update, "good frame", Mode Indication = 3, Mode Request = 2.

Octet	Mapping of bits AMR SID							LSB bit 1
	MSB bit 8	bit 7	bit 6	bit 5	bit 4	bit 3	bit 2	
1	Frame Type (=8)				FQI	Mode Indication		
	1	0	0	0	1	undefined		
2	Mode Request (=2)			spare				
	MSB 0	...	LSB 1	0	0	0	0	0
3	Codec CRC							
	CRC(7)	CRC(6)	CRC(5)	CRC(4)	CRC(3)	CRC(2)	CRC(1)	CRC(0)
4	AMR Core Frame (octet 1)							
	d(0)=s(1)	d(1)=s(2)	d(2)	d(3)	d(4)	d(5)	d(6)	d(7)
5..7								
8				STI	Mode Indication (=3)			undef.
	d(32)	d(33)	d(34) = s(35)	1	1	1	0	

Table 7 summarizes all possible AMR frame format combinations in terms of number of bits in each field.

Table 7. Number of bits for different fields in different AMR frame compositions

Frame Type Index	Frame Type	Frame Quality Indicator	Mode Indication	Mode Request	Codec CRC	Class A	Class B	Class C	Total
						AMR Core Frame			
0	4	1	3	3	8	42	53	0	114
1	4	1	3	3	8	49	54	0	122
2	4	1	3	3	8	55	63	0	137
3	4	1	3	3	8	58	76	0	153
4	4	1	3	3	8	61	87	0	167
5	4	1	3	3	8	75	84	0	178
6	4	1	3	3	8	65	99	40	223
7	4	1	3	3	8	81	103	60	263
8	4	1	3	3	8	39	0	0	58
9	4	1	3	3	8	43	0	0	62
10	4	1	3	3	8	38	0	0	57
11	4	1	3	3	8	37	0	0	56
12	Not used								
13	Not used								
14	Not used								
15	4	0	0	0	0	0	0	0	4

4.4 GSM-EFR Frame Composition

This subclause contains the description of the generic GSM-EFR Frame of Figure 1. The descriptions for the generic GSM-EFR Frame with speech bits and with comfort noise bit are given separately.

4.4.1 GSM-EFR Frame with speech bits

The generic GSM-EFR frame for speech data bits is formed like for the AMR mode 12.2 kbit/s.

The same Frame Type (Frame Type 7) is used also for GSM-EFR. The Mode Indication and Mode Request fields are set to "7". The GSM-EFR Core Frame for speech data bits is identical to the AMR Core Frame for speech data bits in the AMR mode with 12.2 kbit/s.

4.4.2 GSM-EFR Frame with comfort noise bits

The GSM-EFR Frame content for the additional frame type with Frame Type Index 9 in Table 1a are described in this subclause. This consists of the frame related to GSM-EFR Comfort Noise Aspects as specified in [4] and [5].

The comfort noise bits are all mapped to Class A. Classes B and C are not used (see Table 7).

The contents of GSM-EFR SID is the Comfort Noise Parameters ($s(i)$) as defined in [4]. The Comfort noise parameters are computed as described in [5] by the GSM-EFR speech encoder and are denoted as $s(i) = \{s(1), s(2), \dots, s(38), s(87), s(88), \dots, s(91)\}$. The notation $s(i)$ follows that of [4] (Table 6). The notation $d(j) = \{d(0) \dots d(42)\}$ is local to the present document and is formed as defined by the pseudo code below.

for $j = 0$ to 37

$d(j) := s(j+1)$; /* LSP parameters in $s(1)$ to $s(38)$ */;

for $j = 38$ to 42

$d(j) := s(j+49)$; /* fixed codebook gain parameter in $s(87)$ - $s(91)$ */

Table 8 shows the composition for the generic GSM-EFR SID frame.

Table 8: Mapping of the GSM-EFR SID frame into the generic AMR frame format, AMR IF1, Example of a good GSM-EFR SID frame (FQI=1).

Octet	Mapping of bits for GSM-EFR SID							LSB bit 1
	MSB bit 8	bit 7	bit 6	bit 5	bit 4	bit 3	bit 2	
1	Frame Type (=9)				FQI	Mode Indication (=7)		
	1	0	0	1	1	1	1	1
2	Mode Request (=7)			spare				
	1	1	1	0	0	0	0	0
3	Codec CRC							
	CRC(7)	CRC(6)	CRC(5)	CRC(4)	CRC(3)	CRC(2)	CRC(1)	CRC(0)
4	Core Frame (octet 1)							
	$d(0)=s(1)$	$d(1)=s(2)$	$d(2)$	$d(3)$	$d(4)$	$d(5)$	$d(6)$	$d(7)$
5..7								
8								
	$d(32)$	$d(33)$	$d(34)$	$d(35)$	$d(36)=s(37)$	$d(37)=s(38)$	$d(38)=s(87)$	$d(39)=s(88)$
9				spare				
	$d(40)=s(89)$	$d(41)=s(90)$	$d(42)=s(91)$	0	0	0	0	0

Annex A (informative): AMR Interface Format 2 (with octet alignment)

This annex defines an octet-aligned frame format for the AMR codec. This format is useful, for example, when the AMR codec is used in connection with applicable ITU-T H-series of recommendations. The format is referred to as AMR Interface Format 2 (AMR IF2).

The AMR IF2 frame is formed by concatenation of the 4-bit Frame Type field (as defined for AMR IF1 in subclause 4.1.1) and the AMR Core Frame (as defined for AMR IF1 in subclause 4.2) as shown in figure A.1. The length of the AMR Core Frame field depends on the particular Frame Type. The total number of bits in the AMR IF2 speech frames in the different modes is typically not a multiple of eight and bit stuffing is needed to achieve an octet structure.

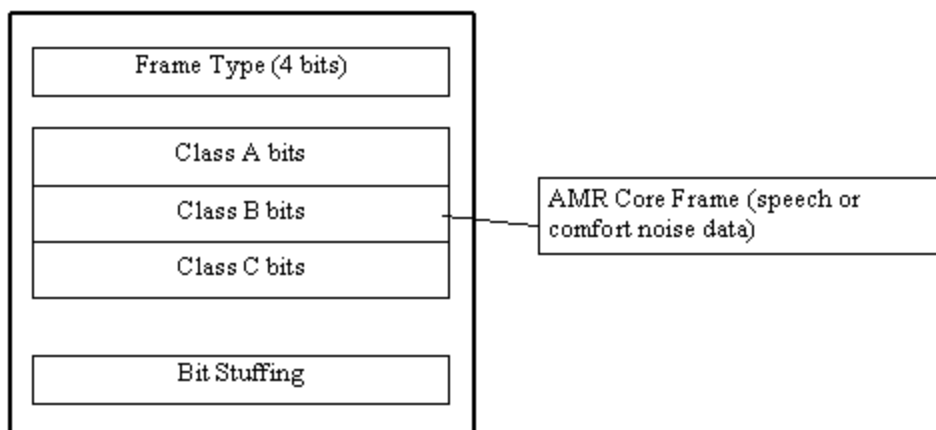

Figure A.1: Frame structure for AMR IF2

Table A.1a shows an example how the AMR 6.7 kbit/s mode is mapped into AMR IF2. The four LSBs of the first octet (octet 1) consist of the Frame Type(=3) for the AMR 6.7 kbit/s mode (see table 1a in AMR IF1 specification). This data field is followed by the 134 AMR Core Frame speech bits ($d(0) \dots d(133)$) which consist of 58 Class A bits and 76 Class B bits as described in table 2 for AMR IF1. This results in a total of 138 bits and 6 bits are needed for Bit Stuffing to arrive to the closest multiple of 8 which is 144 bits.

Table A.1a: Example mapping of the AMR speech coding mode 6.7kbit/s into AMR IF2. The bits used for Bit Stuffing are denoted as UB (for "unused bit").

Octet	Mapping of bits AMR 6.7							LSB
	bit 8	bit 7	bit 6	bit 5	bit 4	bit 3	bit 2	bit 1
1	d(3)	d(2)	d(1)	d(0)	Frame Type (= 3)			
					MSB		
2	d(11)	d(10)	d(9)	d(8)	d(7)	d(6)	d(5)	d(4)
3	d(12)
18	Stuffing bits						d(133)	d(132)
	UB	UB	UB	UB	UB	UB	d(133)	d(132)

Table A.1b shows the composition of AMR IF2 frames for all Frame Types in terms of how many bits are used for each field of figure A.1.

Tables A.2 to A.5 specify how the AMR Core Frame comfort noise bits of Frame Types 8-11 are mapped to AMR IF2. Table A.6 specifies the mapping for an empty frame ("no transmission").

Table A.1b: Composition of AMR IF2 Frames for all Frame Types.

Frame Type Index	Frame content	Number of bits in Frame Type	Number of Bits in AMR Core Frame	Number of Bits in Bit Stuffing	Number of octets (N)
0	AMR 4,75	4	95	5	13
1	AMR 5,15	4	103	5	14
2	AMR 5,90	4	118	6	16
3	AMR 6,70	4	134	6	18
4	AMR 7,40	4	148	0	19
5	AMR 7,95	4	159	5	21
6	AMR 10,2	4	204	0	26
7	AMR 12,2	4	244	0	31
8	AMR SID	4	39	5	6
9	GSM-EFR SID	4	43	1	6
10	TDMA-EFR SID	4	38	6	6
11	PDC-EFR SID	4	37	7	6
12-14	For future use	-	-	-	-
15	No Data	4	0	4	1

Table A.2: Mapping of bits for Frame Type 8 (AMR SID)
(Bits s1 to s35 refer to TS 26.092)

Octet	MSB	Mapping of bits AMR SID						LSB
	bit 8	bit 7	bit 6	bit 5	bit 4	bit 3	bit 2	bit 1
1	Index of 1 st LSF subvector	index of LSF reference vector			Frame Type (= 8)			
	s4	s3	s2	s1	MSB 1 0	LSB 0	0
2	Index of 2 nd LSF subvector	index of 1 st LSF subvector						
	s12	S11	s10	s9	s8	s7	s6	s5
3	index of 2 nd LSF subvector							
	s20	S19	s18	s17	s16	s15	s14	s13
4	index of 3 rd LSF subvector							
	s28	s27	s26	s25	s24	s23	s22	s21
5	SID Type Indicator	frame energy						index of 3 rd LSF subvector
	t1	s35	s34	s33	s32	s31	s30	s29
6	Stuffing bits					Mode Indication		
	UB	UB	UB	UB	UB	MSB mi(2)	LSB mi(1)	mi(0)

Definitions of additional descriptor bits needed for the silence descriptor in the table are as follows: SID-type Indicator STI is {0=SID_FIRST, 1=SID_UPDATE }, Mode Indication (mi(0)- mi(2)) is the AMR codec mode according to the first eight entries in table 1a.

Table A.3: Mapping of bits for Frame Type 9 (GSM-EFR SID)
(Bits s1 to s91 refer to GSM 46.060)

	MSB	Mapping of bits GSM-EFR SID						LSB
Octet	bit 8	bit 7	bit 6	bit 5	bit 4	bit 3	bit 2	bit 1
1	Index of 1 st LSF subMatrix				Frame Type (= 9)			
	s4	s3	s2	s1	1	0	0	1
2	Index of 2 nd LSF submatrix				index of 1 st LSF subMatrix			
	s12	s11	s10	s9	s8	s7	s6	s5
3	Index of 3 rd LSF submatrix				Index of 2 nd LSF submatrix			
	s20	s19	s18	s17	s16	s15	s14	s13
4	index of 4 th LSF submatrix				sign of 3 rd LSF submatrix	index of 3 rd LSF submatrix		
	s28	s27	s26	s25	s24	s23	s22	s21
5	index of 5 th LSF submatrix				index of 4 th LSF submatrix			
	s36	s35	s34	s33	s32	s31	s30	s29
6	Stuffing bit	fixed codebook gain					index of 5 th LSF submatrix	
	UB	s91	s90	s89	s88	s87	s38	s37

Table A.4: Mapping of bits for Frame Type 10 (TDMA-EFR SID)
(Bits cn0 to cn37 refer to IS-641-A)

	MSB	Mapping of bits TDMA-EFR SID						LSB
Octet	bit 8	bit 7	bit 6	bit 5	bit 4	bit 3	bit 2	bit 1
1	Index of 1 st LSF subvector				Frame Type (= 10)			
	cn3	cn2	cn1	cn0	1	0	1	0
2	Index of 2 nd LSF subvector				index of 1 st LSF subvector			
	cn11	Cn10	cn9	cn8	cn7	cn6	cn5	cn4
3	Index of 3 rd LSF subvector			Index of 2 nd LSF subvector				
	cn19	cn18	cn17	cn16	cn15	cn14	cn13	cn12
4	Random Excitation Gain		index of 3 rd LSF subvector					
	cn27	cn26	cn25	cn24	cn23	cn22	cn21	cn20
5	Index of 1 st RESC parameter		Random Excitation Gain					
	cn35	cn34	cn33	cn32	cn31	cn30	cn29	cn28
6	Stuffing bits						Index of 2 nd RESC parameter	
	UB	UB	UB	UB	UB	UB	cn37	cn36

Table A.5: Mapping of bits for Frame Type 11 (PDC-EFR SID)
(Bits s1 to s35 refer to ARIB xx)

	MSB	Mapping of bits PDC-EFR SID						LSB
Octet	bit 8	bit 7	bit 6	bit 5	bit 4	bit 3	bit 2	bit 1
1	index of 1 st LSF subvector	index of LSF reference vector			Frame Type (= 11)			
	s4	s3	s2	s1	1	0	1	1
2	index of 2 nd LSF subvector	index of 1 st LSF subvector						
	s12	s11	s10	s9	s8	s7	s6	s5
3	index of 2 nd LSF subvector							
	s20	s19	s18	s17	s16	s15	s14	s13
4	index of 3 rd LSF subvector							
	s28	s27	s26	s25	s24	s23	s22	s21
5	SID type	frame energy						Index of 3 rd LSF subvector
	t1	s35	s34	s33	s32	s31	s30	s29
6	Stuffing bits							SID type
	UB	UB	UB	UB	UB	UB	UB	t2

Definition of additional descriptor bits needed for the table is as follows: SID-type is {0=POST0, 1=POST1(SID_UPDATE), 2=PRE, 3=POST1_BAD }, where LSB of SID_type is t1 and MSB of SID-type is t2.

Table A.6: Mapping of bit for Frame Type 15 (No Data)

	MSB	Mapping of Bits No Data						LSB
Octet	bit 8	bit 7	bit 6	bit 5	bit 4	bit 3	bit 2	bit 1
1	Stuffing bits				Frame Type (= 15)			
	UB	UB	UB	UB	1	1	1	1

Annex B (normative): Tables for AMR Core Frame bit ordering

This annex contains the tables required for ordering the AMR Core Frame speech bits corresponding to the different AMR modes. These tables represent $table_m(j)$ in subclause 4.2.1 where $m=0..7$ is the AMR mode. The tables are read from left to right so that the first element (top left corner) of the table has index 0 and the last element (the right most element of the last row) has the index $K-1$ where K is the total number of speech bits in the specific mode. For example, $table_0(20)=27$, as defined in table B.1.

Table B.1: Ordering of the speech encoder bits for the 4.75 kbit/s mode: $table_0(j)$

j=0	j=1	j=2
0	1	2	3	4	5	6	7	8	9
10	11	12	13	14	15	23	24	25	26
27	28	48	49	61	62	82	83	47	46
45	44	81	80	79	78	17	18	20	22
77	76	75	74	29	30	43	42	41	40
38	39	16	19	21	50	51	59	60	63
64	72	73	84	85	93	94	32	33	35
36	53	54	56	57	66	67	69	70	87
88	90	91	34	55	68	89	37	58	71
92	31	52	65	86					

Table B.2: Ordering of the speech encoder bits for the 5.15 kbit/s mode: $table_1(j)$

7	6	5	4	3	2	1	0	15	14
13	12	11	10	9	8	23	24	25	26
27	46	65	84	45	44	43	64	63	62
83	82	81	102	101	100	42	61	80	99
28	47	66	85	18	41	60	79	98	29
48	67	17	20	22	40	59	78	97	21
30	49	68	86	19	16	87	39	38	58
57	77	35	54	73	92	76	96	95	36
55	74	93	32	51	33	52	70	71	89
90	31	50	69	88	37	56	75	94	34
53	72	91							

Table B.3: Ordering of the speech encoder bits for the 5.9 kbit/s mode: $table_2(j)$

0	1	4	5	3	6	7	2	13	15
8	9	11	12	14	10	16	28	74	29
75	27	73	26	72	30	76	51	97	50
71	96	117	31	77	52	98	49	70	95
116	53	99	32	78	33	79	48	69	94
115	47	68	93	114	46	67	92	113	19
21	23	22	18	17	20	24	111	43	89
110	64	65	44	90	25	45	66	91	112
54	100	40	61	86	107	39	60	85	106
36	57	82	103	35	56	81	102	34	55
80	101	42	63	88	109	41	62	87	108
38	59	84	105	37	58	83	104		

Table B.4: Ordering of the speech encoder bits for the 6.7 kbit/s mode: $table_3(j)$

0	1	4	3	5	6	13	7	2	8
9	11	15	12	14	10	28	82	29	83
27	81	26	80	30	84	16	55	109	56
110	31	85	57	111	48	73	102	127	32
86	51	76	105	130	52	77	106	131	58
112	33	87	19	23	53	78	107	132	21
22	18	17	20	24	25	50	75	104	129
47	72	101	126	54	79	108	133	46	71
100	125	128	103	74	49	45	70	99	124
42	67	96	121	39	64	93	118	38	63
92	117	35	60	89	114	34	59	88	113
44	69	98	123	43	68	97	122	41	66
95	120	40	65	94	119	37	62	91	116
36	61	90	115						

Table B.5: Ordering of the speech encoder bits for the 7.4 kbit/s mode: $table_4(j)$

0	1	2	3	4	5	6	7	8	9
10	11	12	13	14	15	16	26	87	27
88	28	89	29	90	30	91	51	80	112
141	52	81	113	142	54	83	115	144	55
84	116	145	58	119	59	120	21	22	23
17	18	19	31	60	92	121	56	85	117
146	20	24	25	50	79	111	140	57	86
118	147	49	78	110	139	48	77	53	82
114	143	109	138	47	76	108	137	32	33
61	62	93	94	122	123	41	42	43	44
45	46	70	71	72	73	74	75	102	103
104	105	106	107	131	132	133	134	135	136
34	63	95	124	35	64	96	125	36	65
97	126	37	66	98	127	38	67	99	128
39	68	100	129	40	69	101	130		

Table B.6: Ordering of the speech encoder bits for the 7.95 kbit/s mode: $table_5(j)$

8	7	6	5	4	3	2	14	16	9
10	12	13	15	11	17	20	22	24	23
19	18	21	56	88	122	154	57	89	123
155	58	90	124	156	52	84	118	150	53
85	119	151	27	93	28	94	29	95	30
96	31	97	61	127	62	128	63	129	59
91	125	157	32	98	64	130	1	0	25
26	33	99	34	100	65	131	66	132	54
86	120	152	60	92	126	158	55	87	121
153	117	116	115	46	78	112	144	43	75
109	141	40	72	106	138	36	68	102	134
114	149	148	147	146	83	82	81	80	51
50	49	48	47	45	44	42	39	35	79
77	76	74	71	67	113	111	110	108	105
101	145	143	142	140	137	133	41	73	107
139	37	69	103	135	38	70	104	136	

Table B.7: Ordering of the speech encoder bits for the 10.2 kbit/s mode: $table_6(j)$

7	6	5	4	3	2	1	0	16	15
14	13	12	11	10	9	8	26	27	28
29	30	31	115	116	117	118	119	120	72
73	161	162	65	68	69	108	111	112	154
157	158	197	200	201	32	33	121	122	74
75	163	164	66	109	155	198	19	23	21
22	18	17	20	24	25	37	36	35	34
80	79	78	77	126	125	124	123	169	168
167	166	70	67	71	113	110	114	159	156
160	202	199	203	76	165	81	82	92	91
93	83	95	85	84	94	101	102	96	104
86	103	87	97	127	128	138	137	139	129
141	131	130	140	147	148	142	150	132	149
133	143	170	171	181	180	182	172	184	174
173	183	190	191	185	193	175	192	176	186
38	39	49	48	50	40	52	42	41	51
58	59	53	61	43	60	44	54	194	179
189	196	177	195	178	187	188	151	136	146
153	134	152	135	144	145	105	90	100	107
88	106	89	98	99	62	47	57	64	45
63	46	55	56						

Table B.8: Ordering of the speech encoder bits for the 12.2 kbit/s mode: $table_7(j)$

0	1	2	3	4	5	6	7	8	9
10	11	12	13	14	23	15	16	17	18
19	20	21	22	24	25	26	27	28	38
141	39	142	40	143	41	144	42	145	43
146	44	147	45	148	46	149	47	97	150
200	48	98	151	201	49	99	152	202	86
136	189	239	87	137	190	240	88	138	191
241	91	194	92	195	93	196	94	197	95
198	29	30	31	32	33	34	35	50	100
153	203	89	139	192	242	51	101	154	204
55	105	158	208	90	140	193	243	59	109
162	212	63	113	166	216	67	117	170	220
36	37	54	53	52	58	57	56	62	61
60	66	65	64	70	69	68	104	103	102
108	107	106	112	111	110	116	115	114	120
119	118	157	156	155	161	160	159	165	164
163	169	168	167	173	172	171	207	206	205
211	210	209	215	214	213	219	218	217	223
222	221	73	72	71	76	75	74	79	78
77	82	81	80	85	84	83	123	122	121
126	125	124	129	128	127	132	131	130	135
134	133	176	175	174	179	178	177	182	181
180	185	184	183	188	187	186	226	225	224
229	228	227	232	231	230	235	234	233	238
237	236	96	199						

Annex C (informative): Change history

Change history							
Date	TSG SA#	TSG Doc.	CR	Rev	Subject/Comment	Old	New
1999-12	6	SP-990562			Approved at TSG-SA#6 Plenary		3.0.0
2000-03	7	SP-000025	001		Correction of indices in Annex B table	3.0.0	3.1.0
2000-03	7	SP-000025	002		Addition of comfort noise bit ordering	3.0.0	3.1.0
2000-03	7	SP-000025	003		Correction of table indexing for AMR Core Frame class division	3.0.0	3.1.0
2000-03	7	SP-000025	004		Clarification of bit transmission order for AMR frame structure parameters for AMR Interface Format 1 (AMR IF1)	3.0.0	3.1.0
2001-03	11				Version for Release 4		4.0.0
2001-06	12	SP-010305	006		Correction to SID Frame Mapping	4.0.0	4.1.0
2002-03	15	SP-020077	008		Correction of AMR codec output bitstream	4.1.0	4.2.0
2002-06	16				Version for Release 5	4.2.0	5.0.0
2004-09	25	SP-040644	009	2	Generic Frame Structure for GSM-EFR SID	5.0.0	6.0.0
2004-09	25	SP-040644	010	1	Error Corrections	5.0.0	6.0.0
2007-06	36				Version for Release 7	6.0.0	7.0.0
2008-12	42				Version for Release 8	7.0.0	8.0.0
2009-12	46				Version for Release 9	8.0.0	9.0.0
2011-03	51				Version for Release 10	9.0.0	10.0.0
2012-09	57				Version for Release 11	10.0.0	11.0.0