

3GPP TR 25.991 V5.1.0 (2002-12)

Technical Report

**3rd Generation Partnership Project;
Technical Specification Group Radio Access Network;
Feasibility study on the mitigation of the effect
of the Common Pilot Channel (CPICH) interference
at the User Equipment
(Release 5)**



The present document has been developed within the 3rd Generation Partnership Project (3GPPTM) and may be further elaborated for the purposes of 3GPP.

The present document has not been subject to any approval process by the 3GPP Organizational Partners and shall not be implemented. This Specification is provided for future development work within 3GPP only. The Organizational Partners accept no liability for any use of this Specification. Specifications and reports for implementation of the 3GPPTM system should be obtained via the 3GPP Organizational Partners' Publications Offices.

Keywords

UMTS, radio

3GPP

Postal address

3GPP support office address

650 Route des Lucioles - Sophia Antipolis
Valbonne - FRANCE
Tel.: +33 4 92 94 42 00 Fax: +33 4 93 65 47 16

Internet

<http://www.3gpp.org>

Copyright Notification

No part may be reproduced except as authorized by written permission.
The copyright and the foregoing restriction extend to reproduction in all media.

© 2002, 3GPP Organizational Partners (ARIB, CWTS, ETSI, T1, TTA, TTC).
All rights reserved.

Contents

Foreword	4
1 Scope	5
2 References.....	5
3 Definitions, Symbols, and Abbreviations	6
3.1 Definitions.....	6
3.2 Symbols	6
3.3 Abbreviations	6
4 Background and Introduction	7
5 Performance Evaluation.....	8
5.1 Radio Network Level Simulations	8
5.1.1 Intel Simulation Results	8
5.1.2 Motorola Simulation Results	11
5.1.3 Nokia Simulation Results.....	12
5.1.4 Telia Simulation Results	15
5.1.5 Summary of Radio Network Simulation Results	17
5.1.6 Pilot Interference Mitigation and HSDPA	18
5.2 Link Level Simulations	18
5.2.1 Intel Simulation Results	18
5.2.1.1 Simulation Assumptions	18
5.2.1.2 Simulation Results.....	19
5.2.1.3 Reception Under Non-Ideal Conditions	20
5.2.1.4 Mitigation Accuracy in the Presence of Multiple Neighbour Cells [19]	21
5.2.2 Motorola Simulation Results	22
6 Complexity Evaluation	23
6.1 Intel Complexity Assessment	23
6.1.1 Basic Complexity Assessment	23
6.1.2 Transmit Diversity Operation	23
6.1.3 Multi-Code Operation.....	24
6.2 Motorola Complexity Assessment.....	24
7 Potential Impacts to 3GPP Standard	24
8 Conclusions and Recommendations.....	24
Annex A: Radio Network Simulation Assumptions.....	26
Annex B: Link Level Simulation Assumptions.....	27
Annex C: Change History.....	28

Foreword

This Technical Report has been produced by the 3rd Generation Partnership Project (3GPP).

The contents of the present document are subject to continuing work within the TSG and may change following formal TSG approval. Should the TSG modify the contents of the present document, it will be re-released by the TSG with an identifying change of release date and an increase in version number as follows:

Version x.y.z

where:

- x the first digit:
 - 1 presented to TSG for information;
 - 2 presented to TSG for approval;
 - 3 or greater indicates TSG approved document under change control.
- y the second digit is incremented for all changes of substance, i.e. technical enhancements, corrections, updates, etc.
- z the third digit is incremented when editorial only changes have been incorporated in the document.

1 Scope

The present document assesses the feasibility of mitigating the effect of CPICH interference at the UE. The report includes performance evaluation of this feature using radio network level simulations and link level simulations, and complexity evaluation.

2 References

The following documents contain provisions which, through reference in this text, constitute provisions of the present document.

- References are either specific (identified by date of publication, edition number, version number, etc.) or non-specific.
- For a specific reference, subsequent revisions do not apply.
- For a non-specific reference, the latest version applies. In the case of a reference to a 3GPP document (including a GSM document), a non-specific reference implicitly refers to the latest version of the document *in the same Release as the present document*.

- [1] 3GPP TSGR1-00-1371, "CPICH interference cancellation as a means for increasing DL capacity," Intel, Nov. 2000.
- [2] 3GPP TSGR1-00-0030, "Further Results on CPICH Interference Cancellation as A Means for Increasing DL Capacity," Intel Corporation, Jan. 2001.
- [3] 3GPP TSGR4-01-0238, "CPICH Interference Cancellation as a Means for Increasing DL Capacity," Intel, Feb. 2001.
- [4] 3GPP TSGRP-01-0177, "Mitigating the Effect of CPICH Interference at the UE," Intel Corporation, Mar. 2001.
- [5] 3GPP TSGR4-01-0650, "On the Implementation Complexity of CPICH Interference Cancellation," Intel, May 2001.
- [6] 3GPP TSGR4-01-1014, "On the potential capacity gain of CPICH interference mitigation," Intel, July 2001.
- [7] 3GPP TSGR4-01-1015, "Study description for SI: Mitigating the effect of CPICH interference at the UE," Intel, 7/01.
- [8] 3GPP TSGR4-01-0967, "CPICH cancellation," Motorola, July 2001.
- [9] 3GPP TS 25.101, "UE Radio transmission and reception (FDD)".
- [10] 3GPP TS 25.942, "RF system scenarios".
- [11] 3GPP TS 34.121, "Terminal conformance specification; radio transmission and reception (FDD)".
- [12] 3GPP TSGR4-01-1330, "Feasibility Assessment for CPICH Interference Mitigation", Intel, September 2001.
- [13] 3GPP TSGR4-01-1230, "CPICH cancellation, 2-way soft handoff capacity gain" Motorola, September 2001.
- [14] 3GPP TSGR4-01-1231, "CPICH cancellation, UE sample time offsets" Motorola, September 2001.
- [15] 3GPP TSGR4-01-1232, "CPICH cancellation complexity" Motorola, September 2001.
- [16] 3GPP TSGR4-01-1202, "Simulation results for CPICH interference mitigation" Nokia, September 2001.
- [17] 3GPP TSGR4-01-1256, "Capacity gain from CPICH cancellation", Telia, September 2001.
- [18] 3GPP TSGR4-01-1392, "Comments on the CPICH Interference Cancellation Scheme," Ericsson, Nov. 2001
- [19] 3GPP TSGR4-01-1455, "CPICH Interference Mitigation Accuracy," Intel Corp., Nov. 2001.
- [20] 3GPP TSGR4-01-1483, "Correction on CPICH Interference Mitigation Complexity", Intel, November 2001

3 Definitions, Symbols, and Abbreviations

3.1 Definitions

For the purposes of the present document, the terms and definitions given in TR 21.905 apply.

3.2 Symbols

void

3.3 Abbreviations

For the purposes of the present document, the following abbreviations apply:

BLER	Block Error Ratio
DCH	Dedicated Channel, which is mapped into Dedicated Physical Channel.
DL	Down Link (forward link)
DPCCH	Dedicated Physical Control Channel
DPCH	Dedicated Physical Channel
DPCH_ E_c	Average energy per PN chip for DPCH.
E_c	Average energy per PN chip.
$\frac{E_c}{I_{or}}$	The ratio of the average transmit energy per PN chip for different fields or physical channels to the total transmit power spectral density.
FDD	Frequency Division Duplex
HSDPA	High Speed Downlink Packet Access
I_o	The total received power spectral density, including signal and interference, as measured at the UE antenna connector.
I_{oc}	The power spectral density of a band limited white noise source (simulating interference from cells, which are not defined in a test procedure) as measured at the UE antenna connector.
I_{or}	The total transmit power spectral density of the down link at the Node B antenna connector.
\hat{I}_{or}	The received power spectral density of the down link as measured at the UE antenna connector.
Node B	A logical node responsible for radio transmission/reception in one or more cells to/from the User Equipment. Terminates the Iub interface towards the RNC
OCNS	Orthogonal Channel Noise Simulator, a mechanism used to simulate the users or control signals on the other orthogonal channels of a downlink link.
OCNS_ E_c	Average energy per PN chip for the OCNS.
P-CCPCH	Primary Common Control Physical Channel
PCH	Paging Channel
P-CPICH	Primary Common Pilot Channel
PICH	Paging Indicator Channel
PPM	Parts Per Million
SCH	Synchronization Channel consisting of Primary and Secondary synchronization channels
S-CPICH	Secondary Common Pilot Channel
SIR	Signal to Interference Ratio
STTD	Space Time Transmit Diversity
UE	User Equipment

4 Background and Introduction

The present document provides the results of the 3GPP Study Item on Mitigating the Effect of CPICH (Common Pilot Channel) Interference at the UE. The objective of the study, and thus, of the present document, is to assess the potential benefits of this UE capability and to evaluate its implementation complexity. Additional information on this topic can be found in a number of prior 3GPP contributions [1] to [8].

The idea behind CPICH interference mitigation is to eliminate, or at least reduce, the effect of the multiple access interference (MAI) associated with the Common Pilot Channels (CPICH's) of the same -cell and other-cell Node B's. Since each UE utilizing this ability sees less effective interference, it will require less transmitted power from the Node-B to obtain its desired block error rate. This transmit power savings can be used to support additional cell capacity.

The CPICH channel takes up a significant portion of the total Node-B transmit power, and thus, mitigating its interference effect is particularly advantageous. For example, a Primary CPICH (P-CPICH) power allocation value of 10% (i.e., P-CPICH_Ec/Ior = -10 dB) is suggested in [9], which translates approximately to at least a 10% loss in capacity from pilot interference. In addition, since all of the surrounding Node-B's are unlikely to be transmitting at full power (peak load) at the same time, the percentage of interference attributable to the pilot channels may be larger, (since the CPICH_Ec/Ior is fixed and referenced to maximum available transmit power).

If in addition to the P-CPICH channel there is a Secondary CPICH (S-CPICH) channel enabled, the total relative pilot power increases, e.g., to 20% as [9, annex C.3.2]. In this case, mitigating the effects of both the P-CPICH and S-CPICH channels would provide approximately double the capacity gains.

CPICH interference mitigation is particularly attractive because of its potentially low implementation complexity. The information content and structure of the pilot channels are known a priori at the UE, which can be exploited to simplify the mitigation procedure. Thus, the more costly approaches needed for data channel interference mitigation, are not needed for pilot interference mitigation.

There can be a number of ways to mitigate the effect of CPICH interference. One example approach to CPICH interference mitigation, (based on a form of interference cancellation), is shown in Figure 1 that illustrates the concept [3]. Here, pilot crosscorrelation terms (i.e., interference terms) are computed and subtracted at the output of the RAKE receiver, reducing the interference level seen by the subsequent decoding stage of the detector. The link level simulation results presented here are based on this approach.

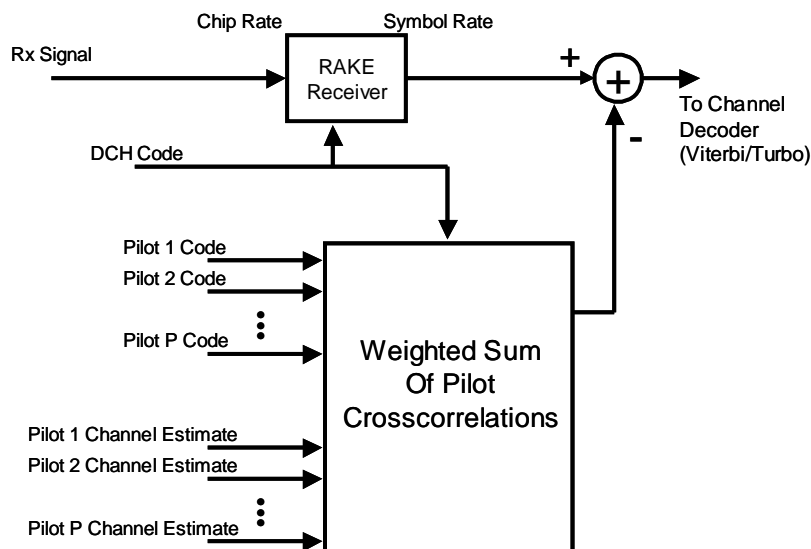

Figure 1: One example approach to mitigating the effect of CPICH interference at the UE

5 Performance Evaluation

5.1 Radio Network Level Simulations

In this clause we evaluate the potential capacity gains of CPICH interference mitigation by means of radio network level simulations. A number of companies have submitted simulation results, which are detailed below.

5.1.1 Intel Simulation Results

The radio network simulations presented here were originally reported in [12] to assess capacity gains available through CPICH interference mitigation. The proposed methodology for the simulations are very similar to the methodology defined in document TR 25.942 [10] for FDD to FDD coexistence studies. For each snapshot of the Monte Carlo simulation, users are randomly placed across the cells, and power control and handover are modeled as described in TR 25.942. System capacity is defined as the number of users supported when the network is loaded to the point where 95% of the users are satisfied. The simulations will focus on a single operator, macro-cell environment and will compare system capacity for systems with and without pilot interference mitigation enabled.

The assumptions for the radio network simulations that were used to generate the results reported in the next clause are shown in annex A, which mostly follow those first presented in [7], (and which are mostly identical to those found in [10]). Two difference are that the maximum number of users in the Active Set was increased to 3, and 3 sector cells were used instead of omni-directional cells, (as requested by Work Group 4 delegates over the email reflector). In addition the 144 kbps service was added for simulation, and the maximum transmit powers for 64 kbps and 144 kbps services were adjusted to reflect more realistic values. Note that the suggested Eb/No target values in Annex A were taken from the Case 3 FDD performance requirements in TS 25.101, (where Ec/Ior requirements were converted to Eb/No requirements by the formula in clause 12 of TS 25.942 [10]). Note also that a 100% activity factor was used for the 12.2 kbps simulations, as in [10], instead of 50% initially specified in [7].

Simulation results for the radio network capacity gains are reported in this clause for 3 cases

1. Cancellation Set (CS) = Active Set (AS); (maximum size of 3).
2. Cancellation Set (CS) = 6 strongest pilots.
3. Cancellation set (CS) = all links (all CPICH channels processed).

Results are summarized in table 1. Note that results are presented both for the case of a constant channel with orthogonality factor of $\alpha = 0.4$, and for the case of a Case 3 fading channel, (as described in [9], Annex B). The results show significant capacity gain.

Table 1: CPICH Cancellation Capacity Gains

Capacity Gain: 12.2 kbps Voice		
	Const. $\alpha = 0.4$	Fading
CS = AS	7.4%	7.4%
CS = 6 Pilots	13.6%	13.3%
CS = All Pilots	15.6%	15.2%
Capacity Gain: 64 kbps Data		
	Const. $\alpha = 0.4$	Fading
CS = AS	9.1%	9.3%
CS = 6 Pilots	15.4%	17.0%
CS = All Pilots	17.6%	19.4%
Capacity Gain: 144 kbps Data		
	Const. $\alpha = 0.4$	Fading
CS = AS	11.1%	7.7%
CS = 6 Pilots	20.6%	20.6%
CS = All Pilots	23.3%	23.3%

The capacity gains available through CPICH interference mitigation are dependent on the cancellation accuracy achievable, as illustrated in figures 2 and 4, (Case 3 fading channel assumed). The link level simulation study results, presented in the next clause, however, demonstrate that high cancellation accuracy is achievable. If one assumes

cancellation accuracy of 85% and a cancellation set of 6, (and we average the results of the two columns), the gains available from CPICH mitigation will be approximately: (1) for 12.2 kbps – 11.4%; (2) for 64 kbps – 13.8%; and (3) for 144 kbps –17.5%.

All of the simulations in this clause were done assuming uniform loading over the network and busy hour (peak) network operation, (with Poisson-like traffic statistics). The capacity gains would improve, however, under situations of non-uniform loading, where some of the surrounding cells were less busy. The reason for this is that the interference due to CPICH channels will then be a larger portion of the total interference seen by the UE from the less loaded cells (see [6]).

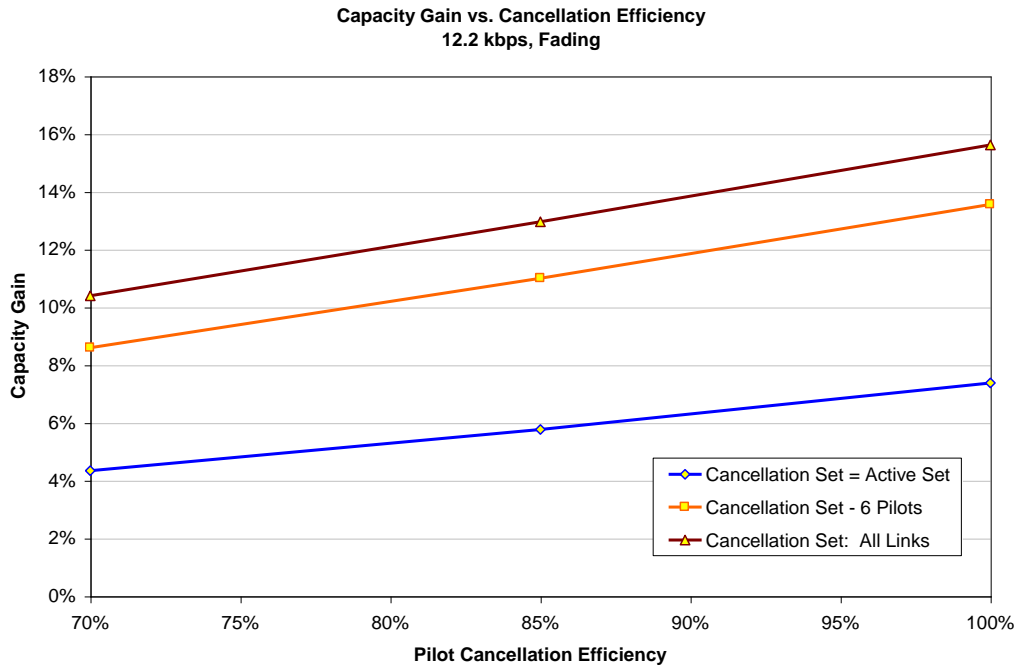

Figure 2: Pilot interference mitigation capacity gain as a function of cancellation accuracy. Results shown for 12.2 kbps, Target SIR = 9 dB, maximum Active Set size = 3 links, Soft handover "add" threshold = -3 dB.

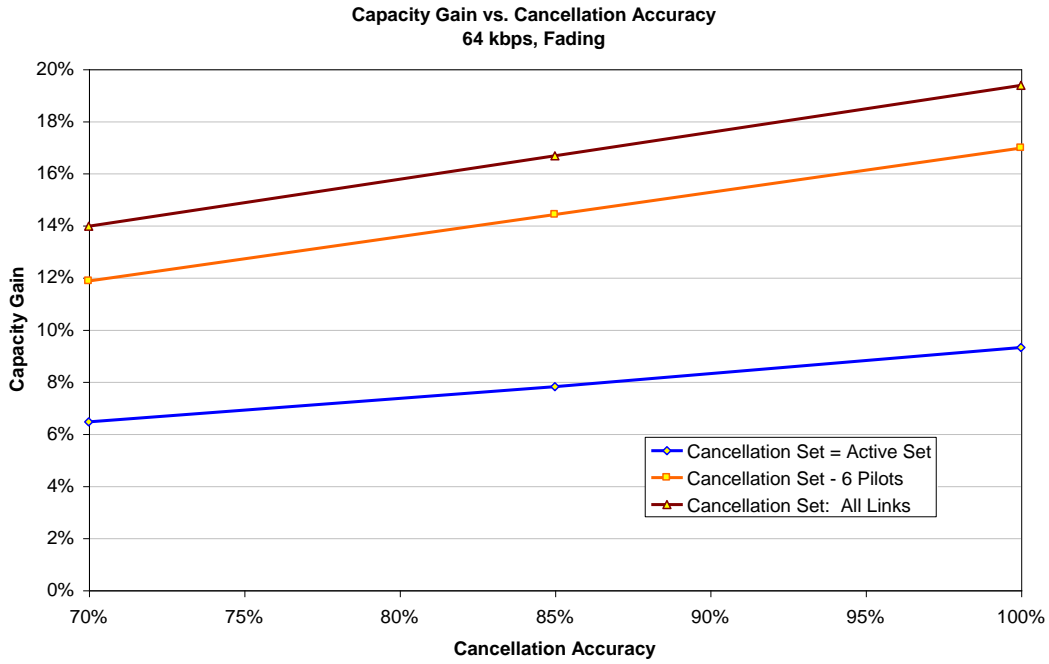

Figure 3: Pilot interference mitigation capacity gain as a function of cancellation accuracy. Results shown for 64 kbps, Target SIR = 5.5 dB, maximum Active Set size = 3 links, Soft handover "add" threshold = -3 dB.

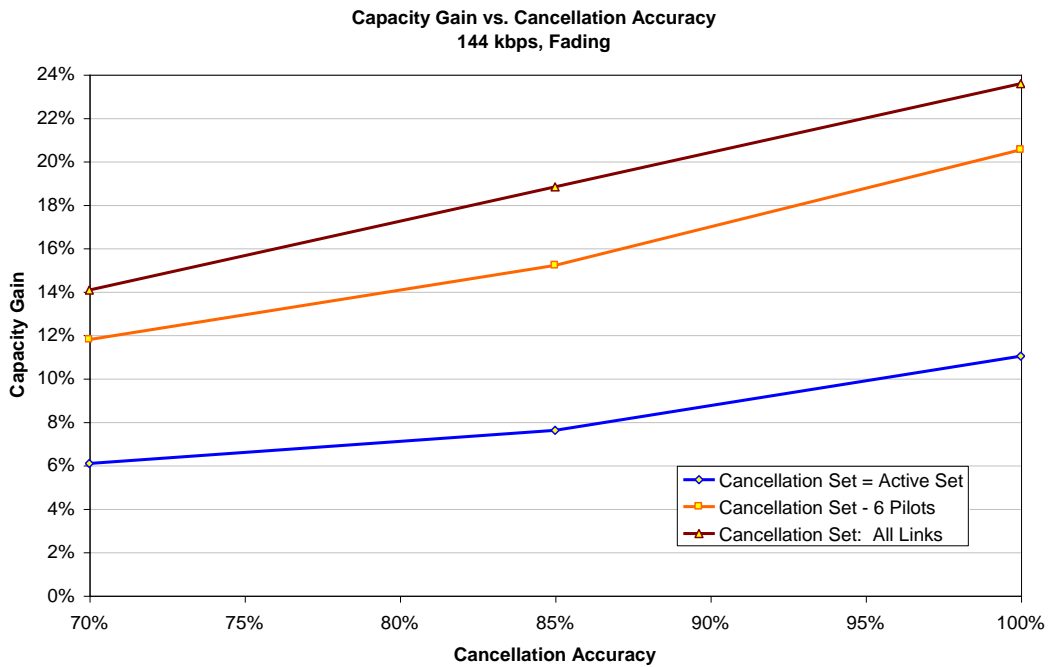

Figure 4: Pilot interference mitigation capacity gain as a function of cancellation accuracy. Results shown for 144 kbps, Target SIR = 5.4 dB, maximum Active Set size = 3 links, Soft handover "add" threshold = -3 dB.

5.1.2 Motorola Simulation Results

A static system simulator is used for the simulation results reported in this clause, and voice capacity is considered [8,13].

The first set of results assumes no soft handoff, and that each user cancels only a single (strongest) CPICH channel that it sees. As seen in Figure 5, the capacity gain in this case is about 7%. Note that the lower graph shows that for the case considered the capacity gain is nearly independent of the required SNR. Simulation assumptions are provided in table 2. Cancellation accuracy is assumed to be ideal.

Table 2: Simulation assumptions used for Figure 5 results

Item	Parameter	Comments
Pathloss exponent	3.7	
Log normal standard deviation	8 dB	
Log normal decorrelation distance	100 meters	
Cell radius	1000 meters	
Antenna front to back ratio	20 dB	
Number of rings of interferers	3	
Number of interfering sectors	110	Three rings of interferers
Mobile antenna	omnidirectional	
Number of sectors per site	3	120° ideal sector antennas (see note)
Other-cell interference	AWGN	
Total transmit power	1.0	System is interference limited
Pilot fractional power	10%	
Power control	Perfect	
Target SINR at RAKE output	+4 dB	Results are not sensitive to this value
Multipath channel gains	[0, -3 dB, -6 dB, -9 dB]	3GPP; 25.101; Annex B
Multipath tap spacing	1 chip (3.84 Mcps)	
Processing gain	128	
NOTE: A 120-degree ideal antenna pattern with 20db front-to-back antenna ratio refers to a "brick wall" antenna pattern with that front-to-back ratio.		

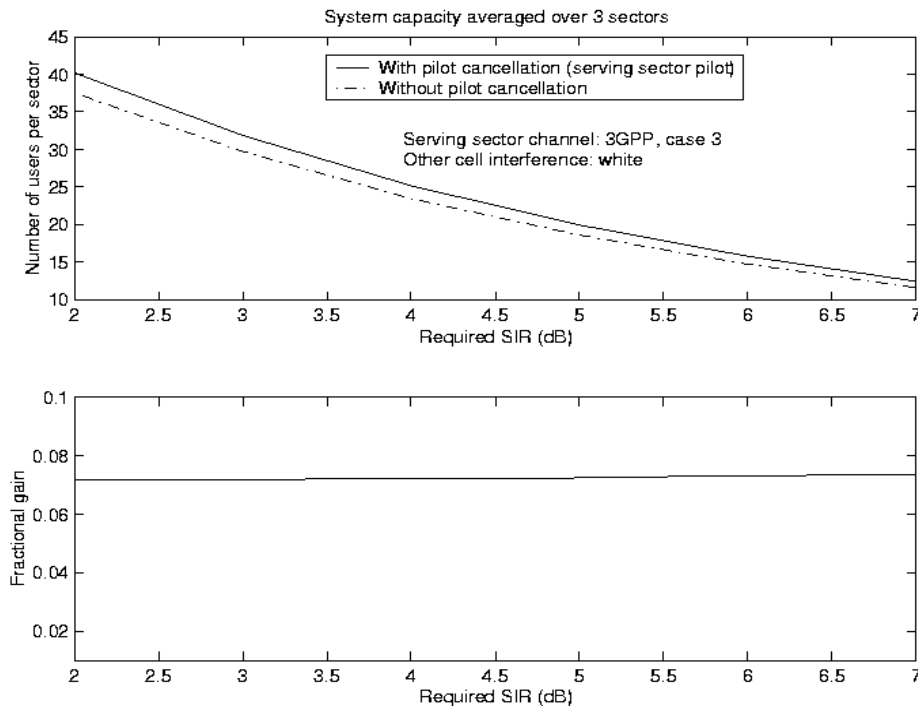

Figure 5: Capacity improvement for tri-sector cell, single base station cancellation. The mobile is not in soft hand-off, and only the serving sector/cell pilot is being cancelled. There are 110 interfering sectors/cells.

Since the above capacity simulation does not take into account adjacent base stations whose pilots may be cancelled, the overall capacity improvement should be greater for a multi-base station cancellation scenario.

The next set of results are based on similar assumptions, with the following differences:

- Two-way soft handoff is simulated, i.e., maximum Active Set size is 2.
- *The cancellation set size used for CPICH Interference Mitigation is assumed to be equal to the Active Set. Thus, users in soft handoff will cancel 2 CPICH channels, and the remaining users will cancel only one CPICH channel. Additional gains are expected if the maximum Active Set size is larger.*
- The UE is randomly placed in the cell (sector) and randomly assigned a given multipath channel model from a set of channel models (different simulation runs use different channel sets).
- The channel models are based on the power profiles used by RAN4 (Case 1 and Case 3, 3GPP TS 25.101).
- Three sets of channel models are considered:
 - 1) Set 1 uses 100% Case 1 (represents the least loss of orthogonality with little diversity).
 - 2) Set 2 consists of 50% Case 1 and 50% Case 3.
 - 3) Set 3 uses 100% Case 3 (represents an increasing loss of orthogonality and the most diversity).
- Adjacent cell loading is fixed at 50% or 100%. Cell loading is defined as the percentage of full power at which the other base stations are operating (in any case, the CPICH power is held constant at -10dB of full cell power).

From figure 6 it is observed that for the cases considered, the capacity gains range from 5.8% to 11.7%. The gains are higher for cases of reduced adjacent cell loading because the fractional part of the interference due to CPICH is greater.

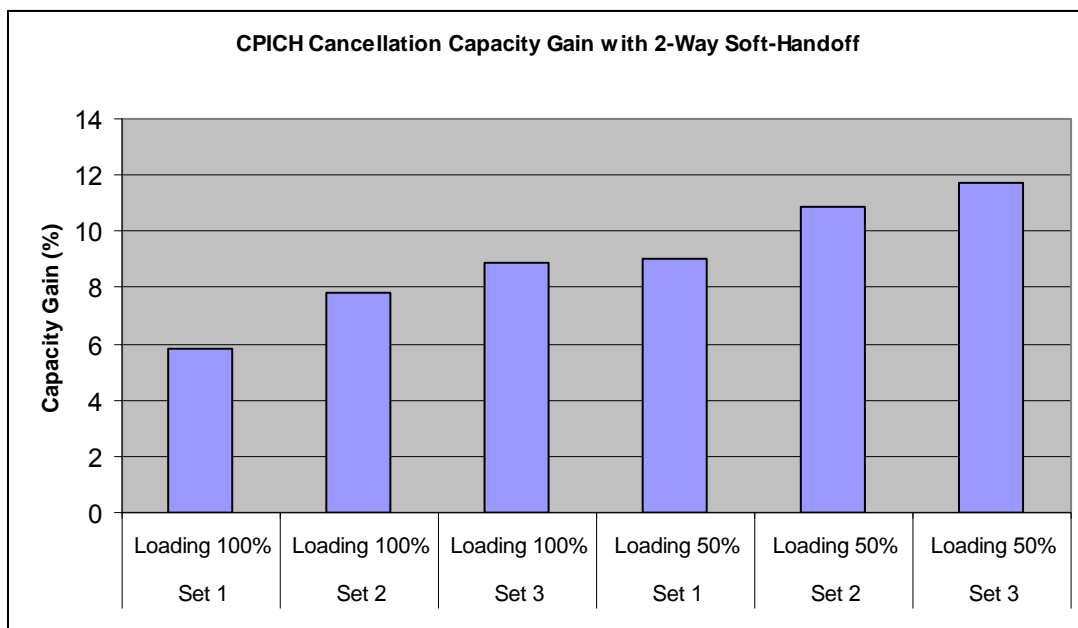

Figure 6: CPICH cancellation capacity gain with 2-way soft handoff, and mitigation of Active Set CPICH channels

5.1.3 Nokia Simulation Results

The results presented in this clause are taken from the simulation results reported in [16]. The simulation assumptions used are mostly the same as those used in clause 5.1.1. One difference is that a maximum Active Set size of 6 is used in addition to maximum size of 3. Also, only voice capacity is considered. In addition, the total common channel power was 5.1 W and the portion of CPICH power from the total common channel power was 2.1 W. Two different schemes have been used for CPICH mitigation, INTRA_CELL and INTRA_INTER_CELL:

INTRA_CELL

Cancellation is performed only for the active set sectors.

INTRA_INTER_CELL

Cancellation is performed for the sectors that are among the N strongest sectors, based on CPICH RSCP measurements. The measurements are performed after every sample step when the terminals are put to new positions.

For the active set sectors a cancellation factor α , which represents the quality of CPICH mitigation, fluctuates from 0 to 1. For neighbor sectors the cancellation factor is $\beta * \alpha$, where $0 < \beta < 1$. The cancellation factor is set independently for the active set cells and neighbour cells in order to allow different cancellation quality since in a real UE implementation the active set and neighbour cells are likely to have different cancellation quality.

The CPICH interference mitigation and SIR calculations have been done using the following formulas.

The total interference observed by UE

$$I_{tot} = \sum_{i=1}^M \left(TxP_{i,CCH} - \beta_i \alpha_i TxP_{i,CPICH} + totTxP_{i,UE} \right) L_i \quad \text{Eq. 1}$$

where M is the number of sectors, α_i and β_i are the cancellation factors for the sector i , $0 \leq \alpha_i, \beta_i \leq 1$, $TxP_{i,CCH}$ is the common channel and $TxP_{i,CPICH}$ common pilot channel power of the sector i , $totTxP_{i,UE}$ is the total user power in sector i , L_i is pathloss between the UE and the sector i .

SIR calculation

The SIR calculation is performed using the formula (2)

$$SIR = \sum_{i=1}^M \frac{G_p TxP_{i,UE} L_i}{I_{tot} + (o - 1) \left(TxP_{i,CCH} - \beta_i \alpha_i TxP_{i,CPICH} + totTxP_{i,UE} \right) L_i} \quad \text{Eq. 2}$$

In this formula M is the number of active set sectors, o is the orthogonality factor, $TxP_{i,UE}$ is the user power in the sector i , and G_p is processing gain. Other variables are the same as in the formula (1).

Three different cases were simulated. In each case the cancellation factors of 0.0, 0.1, 0.5, and 1.0 were used. These simulation cases are shown in table 3.

Table 3: Case studies

Case study	Mode	Maximum active set size	Number of strongest sectors for mitigation	α	β
Case1	INTRA_CELL	3,6	-	0.1, 0.5, 1.0	-
Case2	INTRA_INTER_CELL	3	3,6,10,20	0.1, 0.5, 1.0	1.0
Case3	INTRA_INTER_CELL	3	3,6,10,20	0.1,0.5 1.0	0.5

We started simulations by first performing reference cases without pilot mitigation. The number of users was increased until 5% outage was reached. The obtained number of users in the reference case is marked as N_{ref} . Then the case simulations were run and the number of users was adjusted to achieve 5% outage again. The number of users in this case is marked as N_c . The capacity gain G is defined as $(N_c - N_{ref})/N_{ref}$.

The simulation results are presented in figure 7 and figure 8. The Case 2 results in figure 7 are optimistic since the same CPICH cancellation quality is assumed both for the active set cells and neighbour cells. Hence, the simulation results of Case 2 represent the upper bound for potential capacity gain in the system to be achieved with CPICH cancellation.

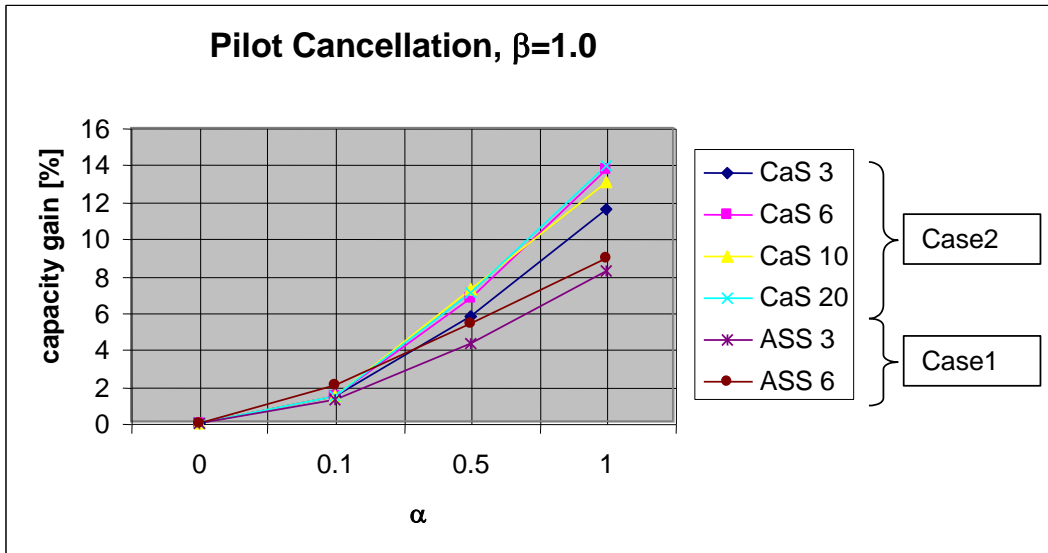

Figure 7 Potential capacity gains in Case 1 and Case 2

Figure 8 presents simulation results with $\beta=0.5$. In this case, the figure shows that the CPICH cancellation of the active set cells seems to give nearly the same capacity gain as the CPICH cancellation of 6 to 20 strongest cells.

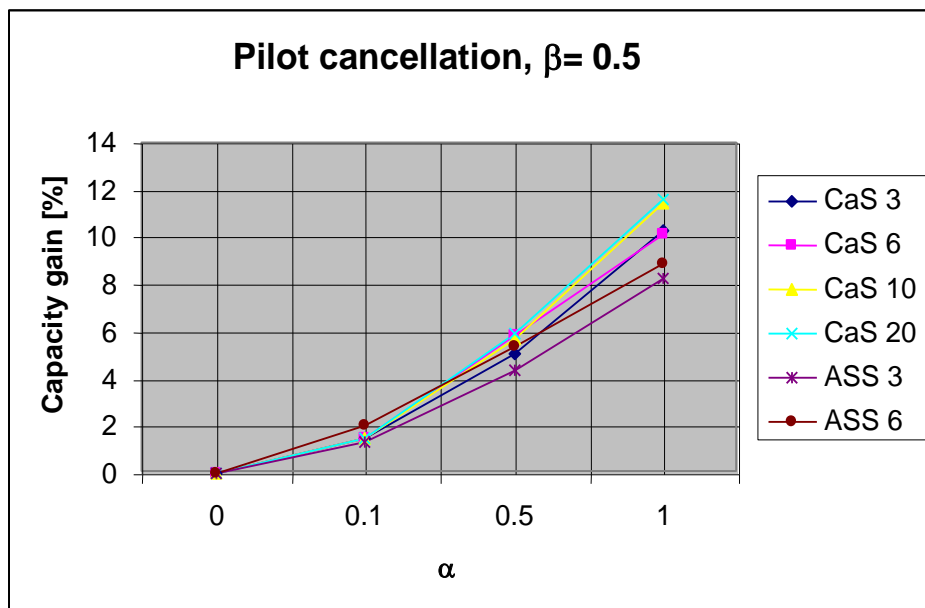

Figure 8: Potential capacity gain in Case 3 compared to Case 1

Figure 9 illustrates the distribution of active set size in Case 1 when the maximum active set size was 6. We can see that only up to 4 cells are actually used in CPICH cancellation in this case.

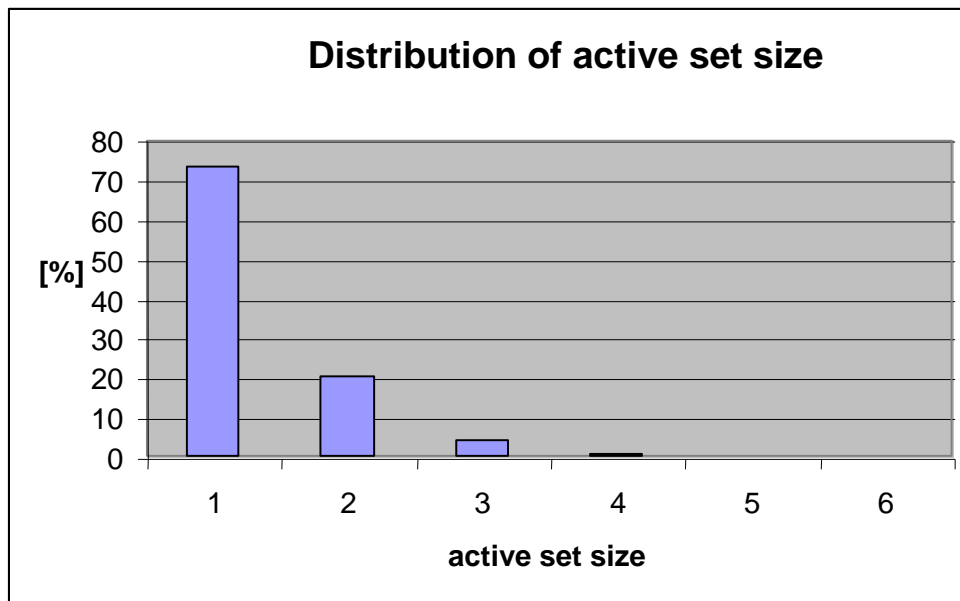

Figure 9 Distribution of the active set size in Case 1 with the maximum active set size of 6

5.1.4 Telia Simulation Results

The results in this clause are based on regulatory requirements in Sweden, where an area is considered to be covered only if the signal strength of the CPICH is -85 dBm or above (with a 95% certainty) [14]. This means that there is a strong correlation between the cell sizes and the power allocated to the CPICH, which can be substantial. In many circumstances, it is purely this requirement on the CPICH that sets the cell sizes and not any requirements on service availability. Thus, CPICH interference mitigation has particular potential to enhance network capacity in this case.

Static simulations have been performed in which the maximum surface outage for users in the downlink was assumed to be 3%. This will define the maximum possible cell radius for a given network load (or mean cell load). The maximum radius is found by varying the cell radius for a fixed load until the surface outage exceeds the specified maximum value. This is then repeated for different loads.

The network consists of 16 sites with omni-directional antennas in a regular hexagonal pattern. Wrapping techniques are used to eliminate any boundary effects. Users are randomly distributed in a homogeneous pattern throughout the network. Shadow fading is taken into account ($\sigma=7$ dB), but fast fading effects are not. No soft handover is assumed; instead a perfect hard handover is implemented. It is further assumed that the common channels, PCCPCH and SCCPCH, are transmitted with a 2 dB lower power than the CPICH. The effects of the SCHs are not considered explicitly. When CPICH cancellation is in effect, all CPICHs are cancelled for all users. Parameters defining the users in the network are shown in table 4 below.

Table 4: Assumptions concerning the traffic in the network

Parameter	Type of user	Type of user
	SPEECH	CS144
Eb/No	7.9 dB	2.5 dB
Bitrate	12.2 kbps	144 kbps
Traffic mix	0.8	0.2
Activity factor	0.5	0.1

The wave propagation model is $PL=K_1 + K_2*\log(d)$, where PL is the path loss and d the distance between receiver and transmitter. The constants K_1 and K_2 are listed in table 5 together with other parameters for the radio environment used in the simulations.

Table 5: Assumed network parameters for the simulations

Parameter	Value
σ	7 dB
Orthogonality factor	0.5
K_1	29.83 dB
K_2	35.22 dB
Max(surface) outage	3%

As mentioned above, we are assuming that the signal strength of the CPICH is fixed in the network, *i.e.* the strength of the CPICH must be above a certain level everywhere in the network (with a 95% certainty). Simple calculations, which depend mainly on the chosen wave propagation model and assumed log-normal fading standard deviation, can be performed to determine the necessary output power of the CPICH for different cell radii. For a signal strength of -85 dBm for the CPICH in the network, the result is shown in figure 10 below. When the cell radius is varied in the simulations to find the maximum cell radius, the CPICH power is thus also varied according to the curve presented in figure 10.

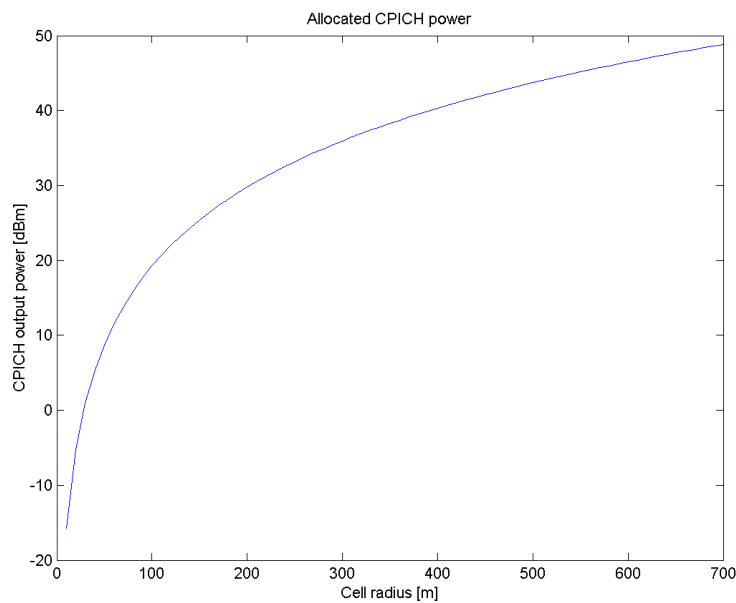

Figure 10: The necessary CPICH output power when a signal strength of -85 dBm everywhere in the network is necessary (with 95% certainty)

Below, we compare the maximum cell radius for the cases of no CPICH cancellation and when CPICH cancellation is employed, see figure 11. The common channels are not affected, of course.

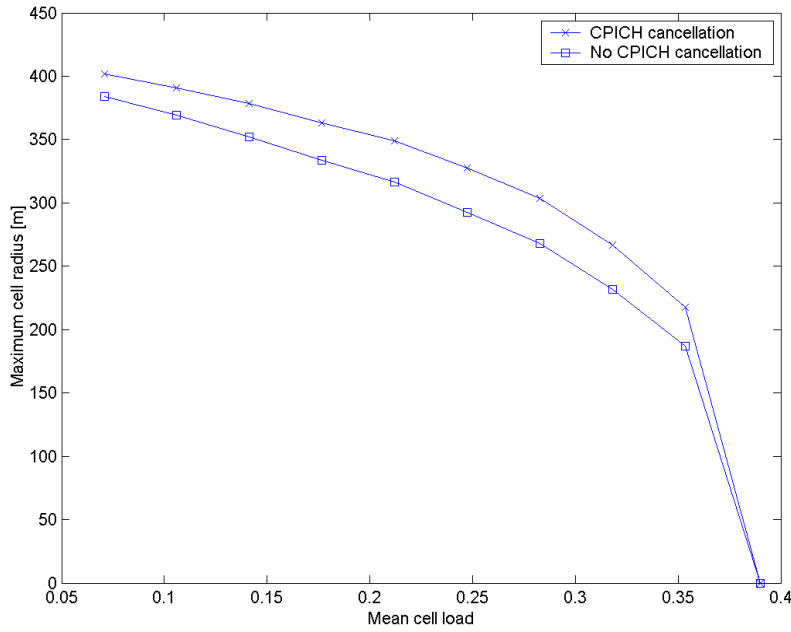

Figure 11: The capacity gain due to CPICH cancellation in an urban environment

The gain in capacity is obvious. The maximum possible cell radius is about 50 m bigger for most cell loads. If we instead consider a fixed cell radius, the gain in possible cell load is quite striking, see figure 12.

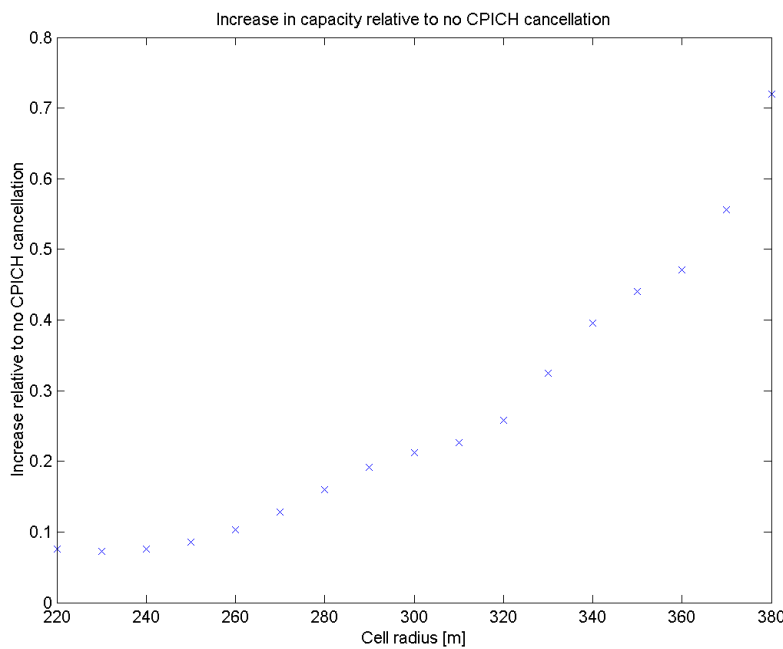

Figure 12: The increase in possible cell load at a fixed cell radius relative to the case when no CPICH cancellation is employed

5.1.5 Summary of Radio Network Simulation Results

We summarize in this clause the capacity results reported in the last few clauses, assuming 100% accuracy in mitigating the CPICH channels being processed. (The next clause will address the issue of mitigation accuracy.) Recall that the simulation assumptions for the Motorola results differed a bit from the simulation assumptions used for Intel and Nokia

results. Telia results were not included in the table since they assess a specific scenario, where the CPICH power is constrained to be very high due to regulatory requirements.

Table 6: Summary of simulations on capacity gains, assuming ideal mitigation (i.e., 100% accuracy)

Cancellation Set	12.2 kbps			64 kbps			144 kbps		
	Intel	Nokia	Motorola (see note 1)	Intel	Nokia	Motorola	Intel	Nokia	Motorola
All sectors	15.4%			18.5%			23.3%		
20 Sectors		13.9%							
10 Sectors		13.0%							
6 Sectors	13.5%	13.7%		16.2%			20.6%		
3 Sectors		11.6%							
Active Set, max size 6		9.0%							
Active Set, max size 3	7.4%	8.2%		9.2%			9.4%		
Active Set, max size 2			5.8% - 11.7% (see note 2)						
1 Sector			7%						
NOTE 1: Simulation assumptions differed somewhat from Intel and Nokia results. See previous clauses.									
NOTE 2: These results were dependent on the load assigned to the surrounding base stations. The upper part of the range resulted from assuming 50% load in surrounding base stations.									

5.1.6 Pilot Interference Mitigation and HSDPA

The performance of pilot interference mitigation in the presence of HSDPA users was discussed in RAN 4 #20, (see also [18]). It was noted that HSDPA users do not have fast forward power control, which is the usual mechanism by which the network can benefit from interference mitigation receivers. The non-HSDPA users, however, can benefit in a similar proportion as to when HSDPA users are not present. For example, if half the cell power is utilized for non-HSDPA users, then the network will achieve approximately half the usual gain – which can then be utilized by the non-HSDPA half of the users. In addition, the HSDPA users can take advantage of pilot interference mitigation by enjoying higher throughput according to their improved SNR.

5.2 Link Level Simulations

In this clause we evaluate the performance of CPICH interference mitigation by means of link level simulations. The objective is to assess the gains of CPICH interference mitigation in realistic receiver conditions as compared to ideal receiver conditions.

5.2.1 Intel Simulation Results

These results, (initially reported in [12]), are presented in order to enable an assessment of the performance under realistic receiver conditions, including imperfect knowledge of channel, frequency, and timing.

5.2.1.1 Simulation Assumptions

The link level simulation assumptions/parameters are described in Annex B, (first presented in [7]). The assumptions mostly follow the standard assumptions used for FDD simulations in Work Group 4. Note that \tilde{I}_{oc} includes the power spectral densities of other-cell base stations that may be included in the simulation, (i.e., in a multi-base link level simulation, whether or not the "other-cell" is in the Active Set). Also, the different values that were listed for CPICH_Ec/Ior were included to enable the study to consider multi-base link level simulations with surrounding cells transmitting at less than full power. Thus, if we assume that P-CPICH_Ec/Ior of the neighboring base station is -7 dB, this corresponds to an assumption of the base station transmitting at 50% of peak transmit power.

The simulations presented in the next clause consider 2 base stations configurations, where pilot interference mitigation is applied to both base stations. This configuration represents a multi-cell environment where a UE receives and mitigates pilot interference from multiple cells. As will be seen below, some of the simulations presented here utilize a

static channel (as defined in [9, annex B]) for the second base station, and some utilize the same fading channel model as the first (reference) base station. The scenarios where both cells experience fading channels are particularly demanding, since the interference seen by each base station is dominated by the fading signals of a single other base station, (and not averaged over a number of base stations).

The simulations consider scenarios with both 1 base station in the Active Set, and in some cases both base stations in the Active Set. For the 2-Base Active Set (i.e., soft handover) simulations, the data channel transmit E_c/I_{or} value was the same at both base stations.

The simulations incorporated soft-handover and other-cell channel fading in order to simulate scenarios that are as realistic and rigorous as possible, as requested by delegates of Work Group 4.

5.2.1.2 Simulation Results

Two sets of link level simulation results are presented in this clause. The first set of results are for simulations with only one base in the Active Set, and where the second base utilizes a Static channel (as defined in [9, annex B]). For the first base station Static and Case 1 channels were considered, as well as both 12.2 kbps voice and 64 kbps data services. These results are presented in figure 13 - figure 14. Curves are presented for RAKE and pilot mitigation performance for the case where $P\text{-}CPICH_E_c/I_{or1}$ is -10 dB and $P\text{-}CPICH_E_c/I_{or2}$ is -7 dB.

In the second set of simulation results both base stations utilize fading channel models, and the results are tabulated in table 8 (in the next clause). Channels considered are Static, Case 1, Case 2, and Case 3, respectively, as well as 12.2 kbps voice and 64 kbps data services. Note that for the Static, Case 2, and Case 3 simulations, both base stations were considered to be in the Active Set, and soft handover was simulated. For the Case 1 simulations, where the first base station's received power is 9 dB larger than the second base station's received power, the second base station was not included in the Active Set. Values are presented for RAKE and pilot mitigation performance for two cases of $P\text{-}CPICH_E_c/I_{or2}$ values, namely -10 and -7 dB. In all cases, the value of $P\text{-}CPICH_E_c/I_{or1}$ is -10 dB.

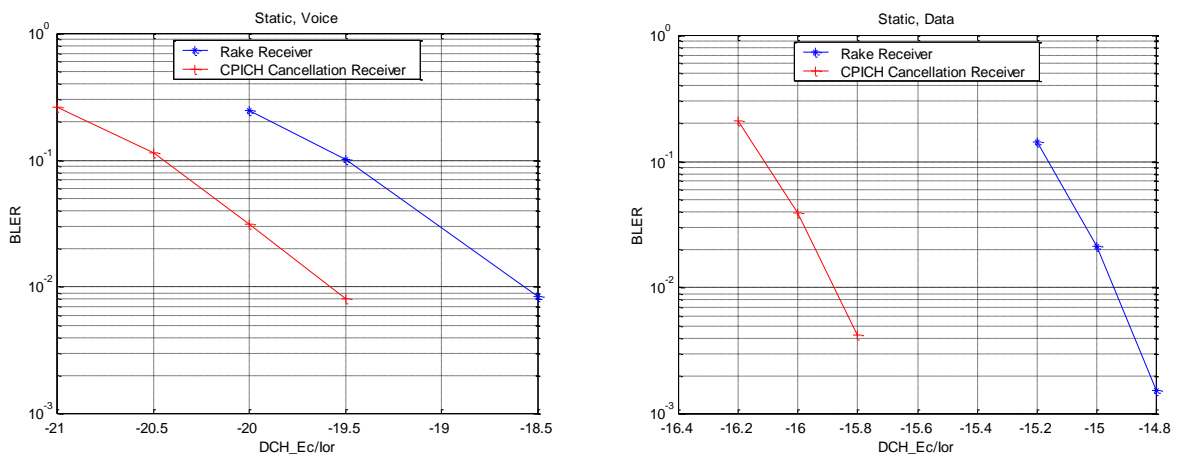

Figure 13: Block error rate as a function of DCH_Ec/Ior for RAKE and Pilot Mitigation receivers, (using the ideal assumptions of Annex B). Results are shown for Static 12.2 kbps and 64kbps channels

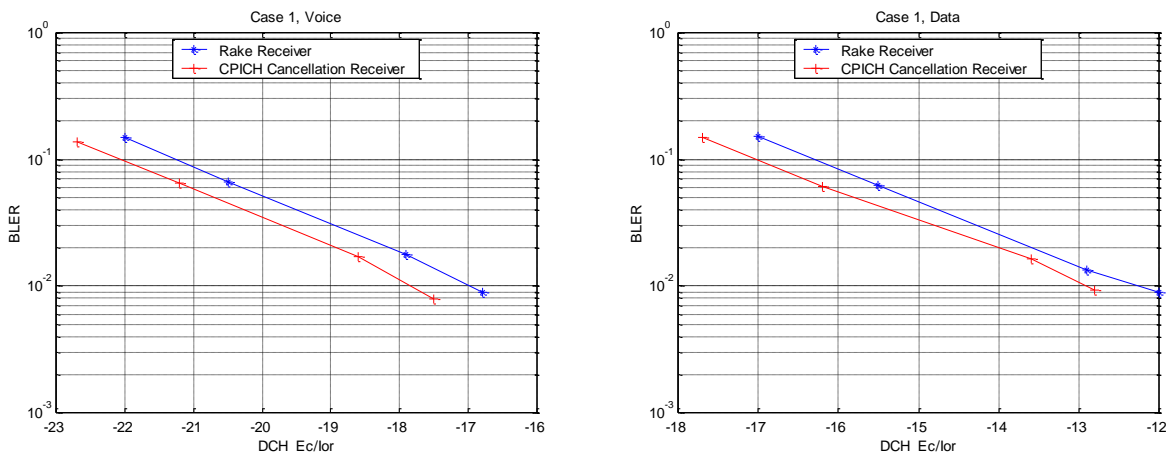

Figure 14: Block error rate as a function of DCH_Ec/Ior for RAKE and Pilot Mitigation receivers, (using the ideal assumptions of Annex B). Results are shown for Case 1 12.2 kbps and 64kbps channels

5.2.1.3 Reception Under Non-Ideal Conditions

In this clause we compare the previous clause's ideal simulation results with more realistic reception conditions, taking into account various receiver impairments and imperfections, including time, frequency, and channel estimation. The assumptions of these simulations include:

- Frequency Drift Model – A +/- 5 ppm crystal is assumed for the UE (resulting in a frequency error of +/-10 KHz before correction).
- Time Drift Model – The time drift is assumed to be caused by frequency error.
- Modified Case 3 Channel Model – In order to consider multipath with non-integer chip delays, we utilized a slightly different delay profile for Case 3 than what appears in [9, annex B], namely [0, 326, 651, 977] ns, (as agreed upon in Work Group 4 email reflector correspondence).

The results of the ideal and non-ideal simulations for the first and second set of experiments are presented in table 7 and table 8, respectively, where the pilot interference mitigation gains are compared for the various simulation conditions. In addition, the average cancellation accuracy is computed for each channel model, (averaging over BER = 1% & 10%, data rates = 12.2 & 64 kbps, and CPICH_Ec/Ior2 = -10 & -7 dB). The results illustrate cancellation accuracy in the neighborhood of 90%. Furthermore, the loss due to non-ideal conditions is within 0.1dB for the vast majority of the test cases

Note that the results in table 8 for Case 1 indicate, that although the second base station is not in the Active Set, (and is in fact 9 dB down from the first base station), the CPICH mitigation still obtained a high degree of cancellation accuracy, (in this case 91.9%).

Table 7: Ideal & Non-Ideal CPICH cancellation gains; Static Ior2, No Soft Handoff

Channel	Service	BLER	Ideal Gain	Non-Ideal Gain	Average Cancellation Accuracy
Static	Voice	10 ⁻¹	0.95dB	0.97dB	95.4%
		10 ⁻²	1.00dB	0.90dB	
	Data	10 ⁻¹	0.95dB	0.90dB	
		10 ⁻²	0.94dB	0.91dB	
Case 1	Voice	10 ⁻¹	0.81dB	0.70dB	97.3%
		10 ⁻²	0.86dB	0.86dB	
	Data	10 ⁻¹	0.73dB	0.74dB	
		10 ⁻²	0.60dB	0.62dB	

Table 8: Ideal & Non-Ideal CPICH mitigation gains; Fading Ior2 (for BS #2); With Soft Handoff in all but Case 1

Channel	Service	BLER	Ec/Ior2 = -10 dB		Ec/Ior2 = -7 dB		Average Cancellation Accuracy
			Ideal Gain	Non-Ideal Gain	Ideal Gain	Non-Ideal Gain	
Static	Voice	10 ⁻¹	0,48 dB	0,40 dB	0,64 dB	0,55 dB	92,7%
		10 ⁻²	0,43 dB	0,41 dB	0,60 dB	0,57 dB	
	Data	10 ⁻¹	0,46 dB	0,43 dB	0,60 dB	0,60 dB	
		10 ⁻²	0,46 dB	0,43 dB	0,60 dB	0,60 dB	
Case 1	Voice	10 ⁻¹	0,52 dB	0,42 dB	0,82 dB	0,76 dB	91,9%
		10 ⁻²	0,36 dB	0,26 dB	0,88 dB	0,73 dB	
	Data	10 ⁻¹	0,49 dB	0,47 dB	0,75 dB	0,79 dB	
		10 ⁻²	0,41 dB	0,46 dB	0,98 dB	0,92 dB	
Case 2	Voice	10 ⁻¹	0,49 dB	0,38 dB			82,8%
		10 ⁻²	0,53 dB	0,48 dB			
	Data	10 ⁻¹	0,47 dB	0,39 dB			
		10 ⁻²	0,48 dB	0,40 dB			
Case 3	Voice	10 ⁻¹	0,40 dB	0,42 dB			93,6%
		10 ⁻²	0,48 dB	0,48 dB			
	Data	10 ⁻¹	0,44 dB	0,38 dB			
		10 ⁻²	0,48 dB	0,37 dB			

5.2.1.4 Mitigation Accuracy in the Presence of Multiple Neighbour Cells [19]

In this clause we consider the accuracy of CPICH interference mitigation for situations with weaker non-Active Set CPICH channels. In order to do so, we consider a particularly demanding scenario:

- Seven base station scenario with relative power levels of: {0, -3, -6.7, -9.0, -11.0, -12.0, -18.0}.
- Only the first two base stations are in the Active Set (in soft handover).

The power levels are approximately equivalent to Ior1/Ior(other) = 0 dB). Note that while the weakest cell above is processed perfectly by the ideal simulations, this cell is ignored by the non-ideal simulations and serves only as a source of additional interference. The simulation parameters are otherwise the same as in the previous clause. (One other difference is that the modified Case 3 channel with non-integer chip multipath delay was used here for both the ideal and non-ideal simulations.)

As in the previous clause, pilot interference cancellation gains were computed for both the ideal and non-ideal simulations by comparing the required Ec/Io needed for the data channel for the pilot cancellation receiver to that needed for the conventional receiver. The cancellation accuracy, or efficiency was computed for each of the scenarios by computing

$$\text{Non-Ideal Gain/Ideal Gain}$$

The results of the simulations are tabulated in table 9. Channels considered are Case 1, Case 2, and Case 3, as well as 12.2 kbps voice and 64 kbps data services. For all simulations, CPICH_Ec/Ior1 = -10 dB. As shown in the table, results are presented for situations where the CPICH_Ec/Ior for the other 6 base stations are either all -10 dB or all -7 dB. The simulation results are presented only for 10% FER, in order to obtain reasonable simulation run-times.

For the slow fading channels of Case 1 and Case 2, the results illustrate cancellation accuracy generally in the neighborhood of 85 to 90%. For Case 3, where the worst case assumption has been made that the mobile is traveling 120 km/h relative to all base stations, (and all multipath components), the cancellation accuracy decreases to 75 to 81%.

The relatively high cancellation accuracy results illustrated here for weaker pilot channels are not intuitively surprising. The major source of potential error in pilot cancellation is generally the channel estimation. Channel estimation, however, enjoys a large processing gain relative to the Doppler frequency, on the order of f (Chip_Rate/Doppler_Frequency). This is equivalent to processing gains of 59 dB and 43 dB for the slow fading and fast fading examples, respectively.

Table 9: Cancellation Accuracy Simulation Results for Various Scenarios (Evaluated at BLER = 10⁻¹)

Channel	Service	CPICH_Ec/Ior {Cells 2-7} = -10 dB	CPICH_Ec/Ior {Cells 2-7} = -7 dB	Average Cancellation Accuracy
Case 1	Voice	92%	89%	88.5%
	Data	86%	87%	
Case 2	Voice	91%	82%	86.8%
	Data	85%	89%	
Case 3	Voice	75%	81%	78.3%
	Data	76%	81%	

5.2.2 Motorola Simulation Results

The results reported in this clause were initially presented in [14]. A list of simulation assumptions is given in table 10. These assumptions include the salient point that the channel models consist of the following different scenarios: balanced and unbalanced two-ray multipath at 3 and 120 Km/h. For the unbalanced case the power profile is {0, -6} dB. Additionally, the UE timing offsets for the two fingers associated with the multipath rays are +0,25 and -0,25 chips. A *1/4-chip fixed-tracking error is significantly greater than the RMS ray tracking error Motorola would expect to observe under typical operating conditions.*

Figure 15a shows the capacity gain due to CPICH cancellation based on the link-level improvement for a given channel condition and cell geometry, assuming no timing offset. Figure 15b is based on the same set of channel conditions with the inclusion of a ±0.25 chip timing offset at the UE. As can be seen, there is a definite degradation due to this sampling offset. However, it should be noted that there is still a discernable link improvement when CPICH cancellation is used. Consequently, there seems to be no reason for concern that CPICH cancellation would degrade a system in the presence of timing offset by the UE.

Table 10: Parameters for Link Level Simulations

Item	Parameter
Data rate	12.2, 144 Kb/s
Channel	2 Ray (balanced), and 2 Ray 0, -6 (unbalanced)
Ior/Ioc	6 dB
Doppler	3 and 120 Km/h
Power control	Inner-loop ON
BLER target	12,2 Kb/s 1%, 144 Kb/s 10%
UE Finger Timing Offset	Figure 1: none Figure 2: +0,25 chip - finger 1, -0,25 chip - finger 2

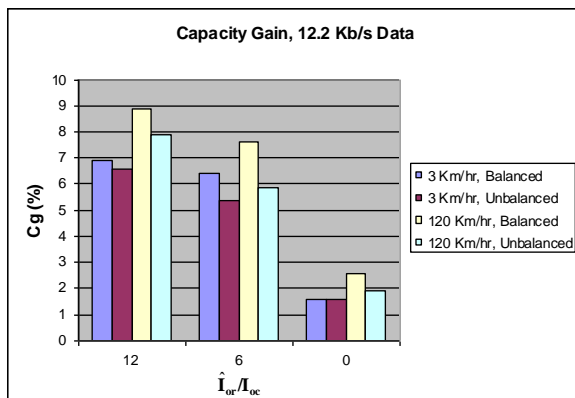

Figure 15a. Capacity gain with no timing offset at UE.

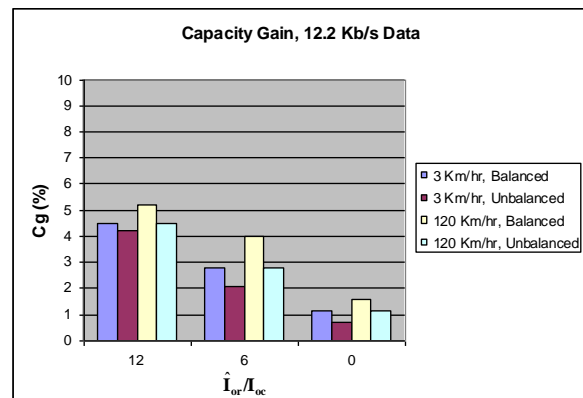

Figure 15b. Capacity gain with ±0.25 chip timing offset at UE.

Figure 15: Capacity gain with and without timing offset at UE.

6 Complexity Evaluation

6.1 Intel Complexity Assessment

The results reported here were initially presented in [5, 12].

6.1.1 Basic Complexity Assessment

This clause summarizes the complexity evaluation reported in [5] for CPICH interference mitigation. This evaluation is based on the pilot cancellation approach illustrated in figure 1 of the present document.

A key component of pilot interference cancellation is the calculation of a cross correlation term between pilot spreading code and voice/data channel spreading code, (see Appendix in [1] for more details). Fortunately, this operation has a very simple hardware implementation, as illustrated in [5].

The other main components needed for CPICH interference cancellation are:

- 1) Pilot despanders, time trackers, and channel estimators.
- 2) Weighting of the crosscorrelations (i.e., according to the channel and transmit/receive filter response) to generate the interference terms.
- 3) Cancellation of the interference terms at the RAKE receiver.

The concept of pilot-cross correlation-selection was also introduced in [5] to illustrate the ability to drastically reduce the number of terms that need to be computed and cancelled. There it was shown that by selecting only the stronger terms for processing, one could reduce implementation complexity, with little resulting performance degradation. Using this approach, it was estimated in [5] and [20] that the total hardware gate count for CPICH interference cancellation is less than 100K gates, the DSP requirements are less than 5 MIPS, and the power consumption is less than 10mW. These numbers were presented simply as comfortable upper bounds, in order to address feasibility.

6.1.2 Transmit Diversity Operation

The CPICH interference mitigation procedure used in the previous clause to evaluate complexity will change somewhat when the UTRAN employs transmit diversity operation. For open loop transmit diversity the main components needed for pilot interference mitigation can be broken down as follows

- 1) Crosscorrelation calculation – Since the scrambling codes are the same the crosscorrelation values for the two antennas will be the same, (except for minor edge effects). The main difference is that the sign of the crosscorrelation for the second antenna will need to be flipped some times (according to the value of the data bit modulated onto the second pilot, which changes every 512 chips).
- 2) Pilot despanders, time trackers, and channel estimators – Since the scrambling codes and timing are the same for the two antennas, no additional pilot despanders, time trackers, or channel estimators are needed for the second antenna.
- 3) Weighting of the crosscorrelations – There will be two times as many crosscorrelation weights to compute and apply to the crosscorrelation values, (follows from the extra set of RAKE fingers). The weight computations for each set of RAKE fingers are very similar, however, and the additional complexity is minor.
- 4) Cancellation of the interference terms at the RAKE receiver – There will be 4 times the number of terms to subtract.

The additional complexity required in steps 3 and 4 will not significantly affect overall complexity. The increased complexity requirements will be less than 10-20% over operation without transmit diversity.

The increased complexity required for implementing CPICH interference mitigation when the UTRAN employs closed loop transmit diversity (modes 1 and 2), will be less than what was described above for open loop transmit diversity. The reason for this is that instead of two sets of RAKE fingers, we now have 1 set of RAKE fingers to cancel pilot interference from.

6.1.3 Multi-Code Operation

If multi-code transmission is employed then CPICH interference mitigation should be performed on each of the multi-code channels. In this case, the main components needed can be broken down as follows:

- 1) Crosscorrelation calculation – For n codes used in multi-code transmission, there will need to be n times the number of crosscorrelation calculations. This, however, will not unduly increase the complexity, since the main component used for crosscorrelation computations can be very simple.
- 2) Pilot despanders, time trackers, and channel estimators – No additional pilot despanders, time trackers, or channel estimators are needed for the second antenna.
- 3) Weighting of the crosscorrelations – The set of crosscorrelation weights needed for one code will be identical for all codes. The reason is that the weights depend on channel weights and timing, which will not change between codes. The only increased complexity involved here will be that the weights will have to be applied to n times more crosscorrelations.
- 4) Cancellation of the interference terms at the RAKE receiver – There will be n times the number of terms to subtract.

Assuming a maximal number of 10 codes for multi-code transmission, the increase in complexity requirements will be less than 50% as compared to the complexity requirements for standard operation, (i.e., Section 6.1.2).

6.2 Motorola Complexity Assessment

The results reported here were initially presented in [15].

Complexity may be addressed in terms of an increase in hardware gate-count and/or an increase in DSP MIPS. Motorola has chosen to address the complexity increase in terms of a gate-count. Note that there are number of factors that affect such an estimate, including the number of branches (fingers) supported, the number of simultaneous channels (codes) supported, the number of CPICH signals cancelled, and the number of interference terms cancelled. Furthermore, the hardware design techniques and simplifications that are employed, including the amount of resource sharing that is used, will also impact the resulting gate-count estimates and may cause differences in the estimates presented by various companies. Nevertheless, "order-of-magnitude" estimates that are based on a reasonable set of assumptions are useful in assessing the performance/complexity trade-offs of implementing CPICH cancellation within the UE.

Using the model presented by Intel, Motorola agrees with Intel that this is implementable in less than 100,000 gates. In addition, with proper resource sharing and other relatively straightforward design simplifications, Motorola believes the gate-count may be reduced even further.

7 Potential Impacts to 3GPP Standard

The potential impact to the standard of techniques such as CPICH interference mitigation would generally be in the form of improved performance requirements, such as would be found in TS 25.101 [9].

8 Conclusions and Recommendations

This study on CPICH interference mitigation addressed the potential capacity gains, feasibility of attaining these gains, and complexity. To summarize:

- **Radio Network Simulations to Evaluate Capacity Gains** - Extensive voice capacity simulations were reported by Intel, Nokia, Motorola, and Telia, with compatible results. In addition, one set of data capacity simulations (for 64 kbps and 144 kbps services) was presented illustrating increased gains over the voice capacity scenario. For a Cancellation Set size of 6, the ideal system level simulation results reported CPICH interference mitigation capacity gains of approximately 13.6% for voice, 16.2% for 64 kbps data, and 20.6% for 144 kbps data. If the Cancellation Set is restricted to the Active Set, these numbers reduce to approximately 7-10%. Consensus was not reached on how best to set the Cancellation Set. It is noted that these capacity gain results will be reduced in realistic reception conditions due to receiver impairments/imperfections. Scenarios where CPICH power is

constrained to be large due to regulatory requirements were also addressed, and interference mitigation was found to be particularly valuable.

- **Link Level Simulations to Evaluate Feasible Accuracy of Cancellation** – Extensive simulation results were reported illustrating varying degrees of cancellation accuracy for the cases considered. The performance of CPICH mitigation under pessimistic timing error conditions was also considered (fixed 1/4 chip timing error for all paths), with reduced gain found. Relatively high cancellation accuracy was found to be feasible even in a demanding 7-sector simulation scenario, which included both stronger cells in a handover state, and weaker neighbor cells.
- **Complexity** – The implementation complexity of mitigating CPICH interference effects was addressed by providing upper bounds on gate count, DSP requirements, and current consumption, but without final consensus reached.

There was general consensus that there are other approaches to improved UE performance, and each UE vendor should be free to choose its preferred approach to meet any new performance requirements. It is recommended that a Work Item be established that will enable the establishment of improved performance for the Release 6 UE.

Annex A: Radio Network Simulation Assumptions

The table below contains a set of standard simulation assumptions used for the Intel and Nokia Radio Network Simulations.

Table A.1: Network simulation assumptions

Parameter	Value
Simulation Type	Snapshot
Network Type	Hexagonal grid – two rings – 19 bases (wrap around technique used); BTS in the middle of cell
User Distribution	Random and uniform across the network
Cell Radius	577 meters
Number Sectors per Base	3 (3-sectored 65 degree antennas)
PROPAGATION PARAMETERS	
Propagation Loss	Loss = $128,15 + 37,6\log_{10}(R)$ dB; R = distance in Km (Macro-cell model as defined in [10])
MCL (including antenna gain)-macro-cell	70 dB
Antenna gain (including losses)	11 dBi at Base; (0 dBi at UE)
Log-normal fade standard deviation	10 dB
Non-orthogonality factor	0,4 (Also, experiments with a Case 3 fading channel model [9, Annex B] were performed)
PC MODELLING	
# of snapshots	> 10000 for speech > 100000 for data
#PC steps per snapshot	> 150
Step size PC	Perfect PC
PC error	0 %
Margin in respect with target C/I	0 dB
Initial TX power	Random initial
Outage condition	Eb/NO target not reached due to lack of TX power
Satisfied user	Measured Eb/NO higher than Eb/NO target - 0,5 dB
HANDOVER MODELING	
Handover threshold for candidate set	3 dB
Maximum number in active set	3
Choice of cells in the active step	Random
Combining	Maximum ratio combining
NOISE PARAMETERS	
Noise figure	9 dB
Receiving bandwidth	3,84 MHz
Noise power	-99 dBm
TX POWER	
Maximum BTS power	43 dBm
Common Channel power	CPICH_Ec/Ior = -10 dB PCCPCH_Ec/Ior = -12 dB SCH_Ec/Ior = -12 dB PICH_Ec/Ior = -15 dB
Power control dynamic range	25 dB
SIMULATED SERVICES	
Data Rates	12,2 (voice), 64 kbps, 144 kbps
Activity factor	100%
Maximum TX power for 12,2 kbps	30 dBm
Maximum TX power for 64 kbps	33 dBm
Maximum TX power for 144 kbps	36 dBm
Eb/No target for 12,2 kbps	9 dB @ 1% FER
Eb/No target for 64 kbps	5,5 dB @ 10% FER
Eb/No target for 144 kbps	5,4 dB @ 10% FER

Annex B: Link Level Simulation Assumptions

The table below contains a set of standard simulation assumptions used for the Intel Link Level Simulations.

Table B.1: Link level simulation assumptions

Parameter	Value				
1) Chip Rate	3.84 Mcps				
2) Closed Loop Power Control	OFF				
3) AGC	OFF				
4) Channel Estimation	Ideal				
5) Number Samples Per Chip	1				
6) Propagation Conditions	As specified in annex B of TS 25.101				
7) Number of Bits in AD Converter	Floating Point Simulations				
8) Number of RAKE Fingers	Equal to number of taps in propagation condition models, (up to a maximum of 6).				
9) Downlink Common Physical Channels and Power Levels (excluding P-CPICH)	CPICH_Ec/lor	= -10, -7, -5 dB			
	PCCPCH_Ec/lor	= -12 dB			
	SCH_Ec/lor	= -12 dB			
	PICH_Ec/lor	= -15 dB			
	OCNS_Ec/lor	As specified in TS 25.101, annex C			
DPCH_Ec/lor	= power needed to meet required BLER target				
10) Target BLER	10^{-1} , 10^{-2}				
11) BLER Calculation	BLER is calculated by comparing transmitted and received bits.				
12) PCCPCH, PICH, DCCH Models	Random symbols transmitted, ignored in the receiver				
13) TFCI Model	Random symbols, ignored in the receiver but it is assumed that the receiver gets error free reception of TFCI information				
14) Used OVSF and Scrambling Codes	Codes are chosen from the allowed set				
15) $\hat{I}_{or} / \tilde{I}_{oc}$ Values	Data Rate	Static	Case1	Case 2	Case 3
	12.2 kbps	-1	9	-3	-3
	64 kbps	-1	9	-3	-3
16) \tilde{I}_{oc}	Combined received power spectral density of AWGN and second base station				
17) Turbo Decoding	MaxLogMap algorithm is used with 8 iterations				
18) SCH Positions	Offset between SCH and DPCH is zero chips, i.e., the SCH overlaps with the first symbols in DPCH at the beginning of DPCH slot structure				
19) Measurement Channels	12.2 kbps and 64 kbps as specified in annex A of TS 25.101 [9]				
20) Phase Reference	P-CPICH				

Annex C: Change History

Table C.1: Change history

Date	TSG #	TSG Doc.	CR	Rev	Subject/Comment	Old	New
12/2001	14	RP-010892		1.0.0	Presented to RAN first time for information		
3/2002	15	RP-020121		2.0.0	Presented to RAN for approval	2.0.0	5.0.0

Table C.2: CR approved at TSG RAN#18

RAN Tdoc	Spec	CR	R	Ph	Title	Cat	Curr	New	Work Item
RP-020800	25.991	001		Rel-5	Correction to Pilot Interference Mitigation Technical Report	F	5.0.0	5.1.0	RInImp-UERecPerf