

3GPP TR 25.968 V11.0.0 (2012-09)

Technical Report

3rd Generation Partnership Project; Technical Specification Group Radio Access Network; 1.28 Mcps TDD Home NodeB Radio Frequency (RF) (Release 11)



The present document has been developed within the 3rd Generation Partnership Project (3GPPTM) and may be further elaborated for the purposes of 3GPP.

The present document has not been subject to any approval process by the 3GPP Organizational Partners and shall not be implemented. This Specification is provided for future development work within 3GPP only. The Organizational Partners accept no liability for any use of this Specification. Specifications and reports for implementation of the 3GPPTM system should be obtained via the 3GPP Organizational Partners' Publications Offices.

Keywords

UMTS, Radio

3GPP

Postal address

3GPP support office address

650 Route des Lucioles - Sophia Antipolis
Valbonne - FRANCE
Tel.: +33 4 92 94 42 00 Fax: +33 4 93 65 47 16

Internet

<http://www.3gpp.org>

Copyright Notification

No part may be reproduced except as authorized by written permission.
The copyright and the foregoing restriction extend to reproduction in all media.

© 2012, 3GPP Organizational Partners (ARIB, ATIS, CCSA, ETSI, TTA, TTC).
All rights reserved.

UMTS™ is a Trade Mark of ETSI registered for the benefit of its members
3GPP™ is a Trade Mark of ETSI registered for the benefit of its Members and of the 3GPP Organizational Partners
LTE™ is a Trade Mark of ETSI currently being registered for the benefit of its Members and of the 3GPP Organizational Partners
GSM® and the GSM logo are registered and owned by the GSM Association

Contents

Foreword	4
1 Scope	5
2 References.....	5
3 Definitions, symbols and abbreviations	5
3.1 Definitions	5
3.2 Symbols.....	5
3.3 Abbreviations.....	5
4 General.....	5
4.1 Task description.....	6
5 Radio scenarios	6
5.1 Deployment configurations.....	6
5.2 Interference scenarios	6
6 HNB class definition	6
6.1 Changes in 3GPP TS 25.105	6
6.1.1 Changes on transmitter characteristics	6
6.1.1.1 Maximum Home NodeB output power.....	6
6.1.1.2 Frequency Accuracy.....	7
6.1.1.3 summary of transmitter change	7
6.1.2 Changes on receiver characteristics	7
6.1.2.1 Sensitivity.....	7
6.1.2.2 Dynamic range	7
6.1.2.3 Adjacent channel selectivity (ACS).....	8
6.1.2.4 Blocking characteristics	8
6.1.2.5 Intermodulation characteristics	8
6.1.2.6 summary of receiver change	8
6.1.3 Changes on demodulation characteristics.....	8
6.2 Changes in 3GPP TS 25.142	9
6.2.1 Changes on transmitter characteristics	9
6.2.2 Changes on receiver characteristics	9
6.2.3 Changes on demodulation characteristics.....	9
7 Guidance on how to control HNB interference	10
7.1 HNB measurements	10
7.2 Control of output power of Home NodeB.....	11
7.3 AGC of Home NodeB	12
7.4 HNB Self Configuration	13
7.4.1 Carrier selection or reselection:	13
7.4.2 Automatic neighbouring cells configuration:	14
7.5 Synchronization	14
7.5.1 Initial synchronization	14
7.5.2 Periodic synchronization.....	15
8 Interference tests.....	16
8.1 Adjacent channel deployment	16
8.2 Co-channel deployment.....	16
Annex A: Change history.....	17

Foreword

This Technical Report has been produced by the 3rd Generation Partnership Project (3GPP).

The contents of the present document are subject to continuing work within the TSG and may change following formal TSG approval. Should the TSG modify the contents of the present document, it will be re-released by the TSG with an identifying change of release date and an increase in version number as follows:

Version x.y.z

where:

- x the first digit:
 - 1 presented to TSG for information;
 - 2 presented to TSG for approval;
 - 3 or greater indicates TSG approved document under change control.
- y the second digit is incremented for all changes of substance, i.e. technical enhancements, corrections, updates, etc.
- z the third digit is incremented when editorial only changes have been incorporated in the document.

1 Scope

This document is a technical report which was requested in the Objective of the RAN4 work item description “1.28Mcps TDD Home NodeB RF requirements” [1]. The goal of this technical report is to describe the agreed approach towards the RF related issues raised in [1]:

- A) The existing 1.28Mcps BS classes did not fully address the RF requirements of the Home NodeB application. Proposals for changes to radio performance requirement specifications TS 25.105 are therefore provided in this report, together with the proposals for the test specification TS 25.142.
- B) The report intends to provide guidance to mitigate interference and clarify some interference cases

2 References

The following documents contain provisions which, through reference in this text, constitute provisions of the present document.

- References are either specific (identified by date of publication, edition number, version number, etc.) or non-specific.
- For a specific reference, subsequent revisions do not apply.
- For a non-specific reference, the latest version applies. In the case of a reference to a 3GPP document (including a GSM document), a non-specific reference implicitly refers to the latest version of that document in the same Release as the present document.

- [1] R4-091435, “WI on 1.28Mcps TDD Home NodeB RF Requirements”, 3GPP RAN WG#46 Sanya China Dec.2009 TD Tech, CMCC, CATT, Picochip Designs, ZTE
- [2] R4-091232, “25.866 TR on 1.28Mcps TDD Home NodeB ”, 3GPP RAN WG#46 Sanya China Dec.2009 TD Tech

3 Definitions, symbols and abbreviations

For the purposes of the present document, the terms and definitions given in TR 21.905 [54] and the following apply. A term defined in the present document takes precedence over the definition of the same term, if any, in TR 21.905 [54].

3.1 Definitions

3.2 Symbols

3.3 Abbreviations

- | | |
|----|-------------------------------------|
| DL | Downlink, the RF path from BS to UE |
| UL | Uplink, the RF path from UE to BS |

4 General

As agreed in the work item proposal [1]:

An increasing need for 1.28Mcps TDD Home NodeBs is observed to provide attractive services and data rates in home environments in China as a consequence of a large number of TD-SCDMA subscribers within recent years.

Whereas UTRAN is not optimally suited for this application, as it was developed and defined under the assumption of coordinated network deployment. Actually home NodeBs are typically associated with uncoordinated and large scale deployment.

Aim of this work item is to amend the 1.28Mcps TDD Home NodeB related RF specifications as suggested in the RAN4 specific part of TR 25.866 to support the Home NodeBs application. No changes to the UE RF specifications are foreseen.

4.1 Task description

TR 25.866 suggests that the existing 1.28Mcps TDD Base Station classes do not fully address the RF requirements of the Home NodeB application. TR 25.866 summarises the areas where changes to TS 25.105 are expected to transmitter characteristics, receiver characteristics and performance respectively. And guidance to mitigate interference and interference test are needed to be investigated. Correspondingly, there are 2 objects in this WI,

- To update the RF requirement specification TS 25.105 as suggested by TR 25.866.
- Guidance to mitigate interference and interference test are need clarification.

5 Radio scenarios

5.1 Deployment configurations

5.2 Interference scenarios

6 HNB class definition

6.1 Changes in 3GPP TS 25.105

This section describes the changes to BS RF requirements specifications TS 25.105

6.1.1 Changes on transmitter characteristics

6.1.1.1 Maximum Home NodeB output power

Maximum output power, P_{max} , of the base station is the mean power level per carrier of the base station measured at the antenna connector in a specified reference condition. The period of measurement shall be a transmit timeslot excluding the guard period. Considering interference of Home NodeB, it is suggested that Home NodeB output power should be controlled. According to TR25.866, Considering two common Home NodeB scenarios(Home and small-scale corporation), the following two Max. output power level are recommended in Table 6.1.1.1-1.

Table 6.1.1.1-1: Recommended power of Home NodeB

Power class	Max. output Power	Scenario
1	20 mW (13dBm)	Home
2	100 mW(20dBm)	Small-scale Corporation

Correspondingly, the rated output power, PRAT, of the Home NodeB is suggested to be specified in the TS 25.105.

In summary, two types of Home NodeB should be defined in specifications, that is,

- type 1: the output power of the Home NodeB is limited to 20 dBm
- type 2: the output power of the Home NodeB is limited to 13 dBm

A minimum requirements was also introduced: In normal conditions, the Base station maximum output power shall remain within +2 dB and -2dB of the manufacturer's rated output power. In extreme conditions, the Base station maximum output power shall remain within +2.5 dB and -2.5dB of the manufacturer's rated output power. In certain regions, the minimum requirement for normal conditions may apply also for some conditions outside the range of conditions defined as normal.

6.1.1.2 Frequency Accuracy

Considering Home NodeBs are usually deployed at home and office, it is most likely that the serving UEs are in slow mobility profile and a consensus was reached that the Home NodeB is expected to support UE speeds up to 30km/h speed during the 1.28Mcps TDD Home NodeB SI.

According to 25.866 simulation results, the Home NodeB modulated carrier frequency can be relaxed to 0.25 PPM.

6.1.1.3 summary of transmitter change

The changes on transmitter characteristics in TS 25.105 are summarised in the following table.

Table 6.1.1.3-1: Changes on transmitter characteristics to TS 25.105

Section	Requirement	Discussion / Required Changes
4.2	Base station classes	Add a new BS class – Home NodeB. Home NodeBs are characterized by requirements derived from Femto Cell scenarios.
6.2.1	Base station maximum output power	Two types of Home NodeB should be defined in specifications, that is, type 1: the output power of the HNB is limited to 20 dBm type 2: the output power of the HNB is limited to 13 dBm
6.3	Frequency error	Added frequency error requirement for Home BS It was agreed on a minimum frequency error of 0.25ppm

6.1.2 Changes on receiver characteristics

6.1.2.1 Sensitivity

According to 3GPP TR25.866, using the reference measurement channel specified in 25.105 Annex A, the reference sensitivity level and performance of the BS shall be as specified in Table 6.1.2.1-1.

Table 6.1.2.1-1: 1.28Mcps TDD Home NodeB reference sensitivity level

BS Class	Reference measurement channel data rate	BS reference sensitivity level	BER
1.28Mcps TDD Home NodeB	12.2 kbps	-101 dBm	BER shall not exceed 0.001

6.1.2.2 Dynamic range

Receiver dynamic range is the receiver ability to handle a rise of interference in the reception frequency channel. The receiver shall fulfil a specified BER requirement for a specified sensitivity degradation of the wanted signal in the presence of an interfering AWGN signal in the same reception frequency channel.

Considering impact of co-channel uplink interference on the Home NodeB, it is possible that Home NodeB receiver will be exposed to strong interference signals from un-coordinated UEs. It was shown that the FDD Home NodeB dynamic range requirement needs to be extended by 20dB to protect the HNB from the strong interference signal of an un-coordinated UE. This conclusion can be reused in 1.28Mcps TDD Home NodeB.

The BER shall not exceed 0.001 for the parameters specified in Table 6.1.2.2-1.

Table 6.1.2.2-1: Dynamic Range of 1.28Mcps TDD Home NodeB Receiver

Parameter	Level	Unit
Reference measurement channel data rate	12.2	kbps
Wanted signal mean power	-51	dBm
Interfering AWGN signal	-47	dBm/1.28 MHz

6.1.2.3 Adjacent channel selectivity (ACS)

Adjacent channel selectivity (ACS) is defined as a measure of the receiver ability to receive a wanted signal at its assigned channel frequency in the presence of a single code CDMA modulated adjacent channel signal at a given frequency offset from the center frequency of the assigned channel. ACS is the ratio of the receiver filter attenuation on the assigned channel frequency to the receiver filter attenuation on the adjacent channel(s).

The BER shall not exceed 0.001 for the parameters specified in Table 6.1.2.3-1.

Table 6.1.2.3-1: Adjacent channel selectivity of 1.28Mcps TDD Home NodeB Receiver

Parameter	Level	Unit
Reference measurement channel data rate	12.2	kbps
Wanted signal mean power	-77	dBm
Interfering AWGN signal	-28	dBm

6.1.2.4 Blocking characteristics

Blocking requirement of Home NodeB is same as Local Area BS.

6.1.2.5 Intermodulation characteristics

Intermodulation requirement of Home NodeB is same as Local Area BS.

6.1.2.6 summary of receiver change

The changes on receiver characteristics in TS 25.105 are summarised in the following table.

Table 6.1.2.6-1: Changes on receiver characteristics in TS 25.105

Section	Requirement	Discussion / Required Changes
7.2	Reference sensitivity level	Added requirement for Home NodeB.
7.3	Dynamic range	Added minimum requirement for Home NodeB.
7.4	ACS	Added minimum requirement for Home NodeB.
7.5	Blocking characteristics	Added minimum requirements for Home NodeB.
7.6	Intermodulation characteristics	Added minimum requirements for Home NodeB.

6.1.3 Changes on demodulation characteristics

To Multi-path Fading environment shown in Table B.2 of 25.105, case 1 is recommended for 1.28Mcps TDD Home NodeB demodulation.

To Propagation Conditions for Multipath Fading Environments for E-DCH Performance Requirements for 1,28 Mcps TDD shown in Table B.2A of 25.105 , ITU Pedestrian A speed 3km/h (PA3), ITU Pedestrian B speed 3km/h (PB3) and ITU vehicular A speed 30km/h (VA30) are suitable to 1.28Mcps TDD Home NodeB.

To Parameters in static propagation conditions and multipath Case 1 channel, Ioc will be changed according to sensitivity of Home NodeB.

6.2 Changes in 3GPP TS 25.142

This section describes the considered changes to base station conformance testing.

6.2.1 Changes on transmitter characteristics

The changes on transmitter characteristics in TS 25.142 are summarised in the following tables. Requirements which are not shown are applicable to Home NodeB without any modifications from the existing specifications.

Table 6.2.1-1: Changes on transmitter characteristics to TS 25.142

Section	Requirement	Discussion / Required Changes
6.2	Base station maximum output power	Two types of Home NodeB should be defined in specifications, that is, type 1: the output power of the HNB is limited to 20 dBm type 2: the output power of the HNB is limited to 13 dBm
6.3	Frequency stability	Added frequency stability requirement for Home NodeB It was agreed on a minimum frequency error of 0.25ppm

6.2.2 Changes on receiver characteristics

The changes on receiver characteristics in TS 25.142 are summarised in the following table.

Table 6.2.2-1: Changes on receiver characteristics in TS 25.142

Section	Requirement	Discussion / Required Changes
7.2	Reference sensitivity level	Added requirement for Home NodeB.
7.3	Dynamic range	Added minimum requirement for Home NodeB.
7.4	ACS	Added minimum requirement for Home NodeB.
7.5	Blocking characteristics	Added minimum requirements for Home NodeB.
7.6	Intermodulation characteristics	Added minimum requirements for Home NodeB.

6.2.3 Changes on demodulation characteristics

To Multi-path Fading environment shown in Table B.2 of 25.142, case 1 is recommended for 1.28Mcps TDD Home NodeB demodulation.

To Propagation Conditions for Multipath Fading Environments for E-DCH Performance Requirements for 1,28 Mcps TDD shown in Table B.2A of 25.142 , ITU Pedestrian A speed 3km/h (PA3), ITU Pedestrian B speed 3km/h (PB3) and ITU vehicular A speed 30km/h (VA30) are suitable to 1.28Mcps TDD Home NodeB.

To Parameters in static propagation conditions and multipath Case 1 channel, Ioc will be changed according to sensitivity of Home NodeB.

7 Guidance on how to control HNB interference

7.1 HNB measurements

The HNB and its HUE can perform some measurements from the surrounding HNB, Macro UE, HUE and Macro NodeB (MNB) such that HNB can apply some algorithms to perform interference mitigation and maintain the HNB coverage. The potential measurements collected by HNB can be through the Connected Mode UEs attached to the HNB during normal operation mode or via a DL Receiver function within the HNB itself in self-configuration mode. Such DL receiver function is also called Network Listen Mode (NLM) or “HNB Sniffer”. The following measurements can be performed by the HNB and its attached HUE and utilized for interference mitigation.

1) P-CCPCH RSCP:

- HNB can inform its DL Receiver HUE perform the PCCPCH RSCP measurement of the neighbouring cells including the Macro NodeB and HNB and report it to the HNB. Based on the measurement, the HNB can estimate the DL interference from neighbouring cell to the HUE, further HNB can control the transmit power of HUE such that the HUE's UL interference to other cells (HNB and Macros) at a reasonable level.
- In “Sniffer mode”, HNB itself can also perform the P-CCPCH RSCP of the neighbouring cells including the Macro NodeB and HNB and can estimate the DL interference towards the HUE. Base on the measurement, HNB can control the HUE transmit power such that the HUE UL interference to other cells (HNB and Macros) at a reasonable level.
- As the 1.28Mcps TDD system usually operate in multiple carrier, the measurements of the PCCPCH RSCP and UTRA RSSI can help the HNB choose the proper carrier with less interference to reside on or estimate the potential interference from the neighboring cell to the HUE, such that it can perform the power control or shift to another carrier to avoid the interference.

2) ISCP:

- HNB can perform the ISCP measurement in a specified time slot in uplink and thus it can estimate the interference from neighbouring cell in both UL and DL. If the ISCP measurement value is larger than a pre-defined threshold (where an interfering MUE is close to HNB), which would mean the MUE's Txpower cause significant interference towards the HNB, HNB can choose to shift to work in another carrier to avoid the strong UL interference or communicate with the interfering cell to coordinate the interference.
- HNB can in form the HUE perform the ISCP and report the ISCP measurement in DL. Judging from the report, HNB can estimate the interference level such that it can perform transmit power control or coordinate the HUE to another timeslot or carrier to avoid the interference.

3) Midamble Strength of Neighbouring Cells:

- By self-configuration, HNB can have the neighbouring cell list and the midamble sequences used by the neighbouring cells. When HNB experiences the strong interference in UL, it can find the potential interfering cell by estimating the Midamble strength of the potential cells for the neighbouring list such that HNB can avoid the strong interference by shifting to another carrier or scheduling HUE to another UL time slot.
- As 1.28Mcps TDD system operate in multiple carriers, usually only the primary carrier have the P-CCPCH, when HUE experience some strong interference from the secondary carrier of some neighbouring cells in DL, HUE can estimate the interference strength by estimating the midamble strength of the potential neighbouring cells and report to the HNB. Base on the report, some interference management can be performed by the HNB.

4) Macro/HNB Cell to HNB Pathloss:

- In self-configuration mode, HNB can read the BCH of macro cell and neighbouring HNB and know the transmit power of the P-CCPCH. Knowing the P-CCPCH transmit power and the received power of the P-CCPCH, HNB can deduce the pathloss from Macro cell or neighbouring HNB to HNB. By knowing the Pathloss from Macro Cell/Neighbouring to HNB, HNB can adjust it's transmit power or control the transmit power of the HUE such that it have less interference to the neighbouring or it can control the DL and UL performance at a reasonable level.

5) Cell ID, LAC and RAC Measurements:

- The HNB can have the Cell ID or LAC or RAC information in self-configuration and normal configuration by performing the physical layer measurement and reading BCH of macro cell and neighbouring HNB. Based on the measurements, HNB can identify its surrounding macrocells and other HNBs nearby, and broadcast the information to the HUE to have HUE distinguish the HNB cell and Macro Cell for purposes such as mobility handling and cell reselection etc.

7.2 Control of output power of Home NodeB

Considering interferences between Home NodeB and Macro BS and among Home NodeBs, interference scenarios are listed in Table 1 and shown in Figure 1 and Figure 2. To scenario 2, Home NodeB Downlink will interfere with Macro UE. The worst case is that the Macro UE is close to Home NodeB and Macro UE located at the cell edge of Macro BS. Of course, the output power of Home NodeB is big factor to this scenario. To scenario 6, Home NodeB Downlink will interfere with HUE which belongs to other Home NodeB.

Table 7.2-1: Interference Scenarios

Number	Aggressor	Victim
1	UE attached to Home Node B (Uplink)	Macro Node B Uplink
2	Home Node B (Downlink)	Macro Node B Downlink (UE)
3	UE attached to Macro Node B (Uplink)	Home Node B Uplink
4	Macro Node B (Downlink)	Home Node B Downlink
5	UE attached to Home Node B (Uplink)	Home Node B Uplink (Home NodeB)
6	Home Node B (Downlink)	Other Home Node B Downlink (UE)

3GPP 25.866 gives the simulation result of scenario 2. It is shown results in high outage probability and throughput loss are indicated at locations where the macro P-CCPCH and HSDPA are fairly weak for the co-channel deployment. In this case the interference can be reduced for example by lowering the Home NodeB maximum output power. According to the simulation results, there is a need to set the maximum Home NodeB output power to lower than 0dBm, or in some cases even below that, in order to obtain an acceptable “coverage vs. interference” trade-off.

The adjacent channel deployment is found to work much better. The Home NodeB maximum output power could be much higher than the co-channel deployment scenario. However, assuming some form of downlink interference control also for the adjacent channel scenario could further improve the HNB performance.

In this scenario, Home NodeB should have capability to know the interference strength between Macro UE and Home NodeB. e.g. Home NodeB measure uplink interference result from Macro UE. If uplink interference is beyond the limitation which is set by Home NodeB itself, Home NodeB can suppose that Macro UE is approaching Home NodeB, and Home NodeB will decrease the output power of Home NodeB. If uplink interference is below the limitation which is set by Home NodeB itself, Home NodeB will ignore interference from Macro UE, common power control algorithm are applied to power control of Home NodeB.

It is also a solution that Maximum output power of Home NodeB will be set according to P-CCPCH RSCP of Macro BS for mitigating Macro UE interference result from Home NodeB, especially when Macro UE is at the edge of the cell with bad reception quality. In detail, When Home NodeB is close to Macro BS, Home NodeB can be set high output power because Macro UE have good reception quality in this area. When Home NodeB is the edge of cell, Home NodeB can be set low output power because Macro UE have bad reception quality in this area. Additionally, if P-CCPCH RSCP of Macro BS is so low that no Macro BS can have in the vicinity of Home NodeB. In this case, Home NodeB can transmit with maximum output power.

3GPP 25.866 gives the simulation result of scenario 6. It is shown that frequency reuse 3 can increase the throughput of Home NodeB. In order to enhance the throughput of HNB, more frequency band should be reserved for Home NodeB. In this scenario, the distance between Home NodeBs is key point to mitigate interference. However, it is managed by operators. So it is suggested that Home NodeB should have capability to know the uplink interference strength.

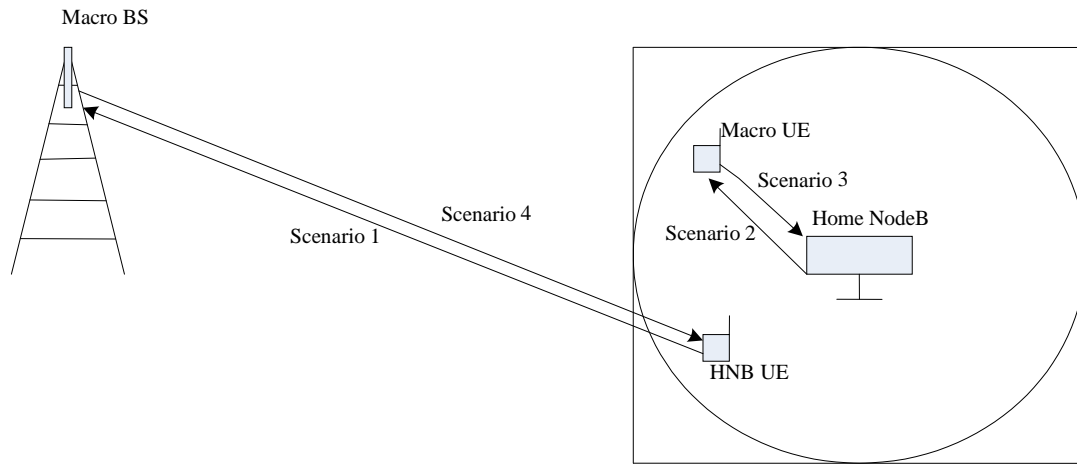

Figure 7.2-1: Interference Scenarios 1, 2, 3 and Scenarios 4

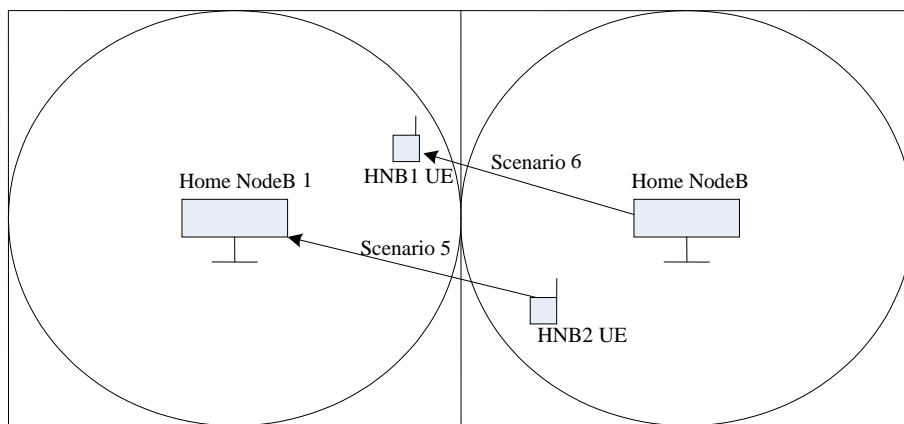

Figure 7.2-2: Interference Scenarios 5 and Scenarios 6

It is suggested that control of output power can be one of efficient interference mitigation method. It is also suggested that Home NodeB should have capability to know the uplink interference strength. And Maximum output power of Home NodeB will be set according to P-CCPCH RSCP of Macro BS for mitigating Macro UE interference result from Home NodeB, especially when Macro UE is at the edge of the cell with bad reception quality.

7.3 AGC of Home NodeB

AGC(Automatic Gain Control) is an alternative mitigation technique to address UL interference from uncontrolled UEs towards the HNB and increase in noise rise from a HUE that cannot be powered down due to limited dynamic range.

25.866 gives that 1.28Mcps TDD Home NodeB dynamic range requirement needs to be extended by 20dB to protect the HNB from the strong interference signal of an un-coordinated UE. Dynamic range of 1.28Mcps TDD Home NodeB is also asked that the BER shall not exceed 0.001 for the parameters specified in shown in Table 7.3-1.

Table 7.3-1: Dynamic Range of 1.28Mcps TDD Home NodeB Receiver

Parameter	Level	Unit
Reference measurement channel data rate	12.2	Kbps
Wanted signal mean power	-51	dBm
Interfering AWGN signal	-47	dBm/1.28 MHz

Adjacent channel selectivity (ACS) requirement is also tighten. The BER shall not exceed 0.001 for the parameters specified in Table 7.3-2. The interfering AWGN signal is increased to -28dBm.

Table 7.3 -2: Adjacent channel selectivity of 1.28Mcps TDD Home NodeB Receiver

Parameter	Level	Unit
Reference measurement channel data rate	12.2	kbps
Wanted signal mean power	-77	dBm
Interfering AWGN signal	-28	dBm

This mitigation approach is based on dynamic control of the receiver gain or UL attenuation, also known as AGC(Automatic Gain Control). Because receiver performance is increased, Home NodeB Up link is no longer blocking by interfering UE.

Home NodeB can adjust the receiver gain or UL attenuation, driven by UL measurements. Blocking levels of UL noise rise due to interference can be detected and the receiver gain reduced accordingly. This adjustment would only need to be made temporarily while the UL interference was strong and as soon as the noise rise was seen to fall the receiver gain could be returned to its normal operating value.

Home NodeB would response this adjustment quickly when the UL interference is strong or noise rise from a HUE is high and slowly decay with time, e.g., to accommodate variations in interference due to bursty traffic. Therefore, it is crucial to determine the correct amount of attenuation that will improve the HUE's performance without degrading the MUEs.

It is suggested that AGC can be one of efficient interference mitigation method to Home NodeB.

7.4 HNB Self Configuration

Self configuration can be applied in HNB to mitigate the interference between HNB and neighbour Macro NodeB/neighbour HNB. The trigger of HNB self configuration could be power up, event triggered or periodical measurement report. The following self configuration can be performed by the HNB to mitigate the interference between HNB and Macro NodeB.

7.4.1 Carrier selection or reselection:

In general, HNB should have abilities to select a carrier frequency using the information of DL and UL interference measurement. For example, HNB or HNB controlled HUE can measure the P-CCPCH RSCP or DL/UL Timeslot ISCP of neighbour Macro NodeB or HNB. When HNB is power on or self configuration is triggered by interference measurement, HNB should select a carrier frequency with smallest interference as its operating frequency.

As the 1.28Mcps TDD system usually operate in multiple carriers, HNB need to detect the carrier occupation status of neighbour cell's primary frequency and secondary frequency.

- If DwPTS or P-CCPCH is detected on one candidate carrier, this carrier can be affirmed to be occupied by one neighbour cell's primary frequency. Furthermore, HNB can decode the BCH channel to differentiate the neighbour Macro NodeB and HNB.
- If no DwPTS or P-CCPCH is detected on one carrier, HNB or HNB controlled HUE can measure the RTWP or UL/DL ISCP of the candidate carrier. If the RTWP or ISCP is higher, this carrier may be occupied by neighbour Macro NodeB or HNB's secondary frequency. HNB should select another carrier with smaller RTPW or ISCP as its working frequency.
- The HNB carrier selection priority should be: HNB secondary frequency > HNB primary frequency > Macro NodeB's secondary frequency > Macro NodeB's primary frequency.

If the frequency of Macro NodeB and HNB is pre-configured with different carrier, HNB needn't to mitigate the HNB-macro interference. HNB only need to detect the carrier occupation status of neighbour HNB's primary and secondary frequency, and select carriers with smaller interference.

If the frequency of Macro NodeB and HNB is mixed, HNB could detect and distinguish the primary frequency of neighbour Macro NodeB and HNB by BCH information, If HNB carrier selection procedure is limited to the HNB self-

obtained information, HNB can't distinguish the secondary frequency of neighbour Macro NodeB and HNB. While the HNB can report neighbour cell's ID to the network controller (i.e. Core Network, HNB-GW), the network controller can feedback the secondary frequency of the corresponding neighbour cell.

Based on the neighbour cell primary and secondary frequency measurement, HNB can mitigate the HNB-macro and HNB-HNB interference.

7.4.2 Automatic neighbouring cells configuration:

During the HNB self-configuration mode, HNB should be able to decode the neighbour cells broadcast information and build the following cell lists for inter-cell interference mitigation:

- Neighbour cell list including Macro NodeBs: The purpose of the neighbour list is to mitigate the UL interference of serving HNB to neighbour Macro NodeBs.
- Neighbour cell list including HNBs. The purpose of the neighbour list is to mitigate the UL interference of serving HNB to neighbour HNBs.

HNB and HUE can use the following neighbour cell organisation and SNPL reporting mechanism to control the UL interference of serving HNB to neighbour Macro NodeB and HNB.

- By searching the DwPTS of neighbour Macro NodeB and HNB, and decoding the BCH channel, HNB can get the information of neighbour Macro NodeB and HNB. If each HNB is configured with a LAC that is different from the surrounding macro cells and nearby HNBs, HNB can differentiate the neighbour Macro NodeB and HNB.
- If the neighbour cell list contains all Macro NodeB, HUE can calculation its pathloss to all intra-frequency neighbour Macro cell. In turn, HUE can estimate the mean pathloss to the serving cell (L_{serv}) and to each of the N neighbour cells, and report the SNPL (Serving and Neighbour cell Pathloss) to serving HNB. Based on the SNPL reporting, serving HNB can control the HUE's interference to neighbour Macro NodeBs under the predefined interference target.
- If the neighbour cell list contains neighbour HNB, HUE can calculation and report the SNPL of neighbour HNB to serving HNB. In turn, serving HNB can control the HUE's interference to neighbour HNBs under the predefined interference target.

Based on the neighbour cell self configuration in HNB, Some ISCP control method could be introduced in Home NodeB environment. E.g. the same ISCP control method as Macro NodeB or the maximum UL output power of Home UE should be limited by the self optimization process of Control HNB according to the neighbour Home Node B number and distance.

7.5 Synchronization

7.5.1 Initial synchronization

Home Node B should detect Macro Node B's DwPCH, and define its timing benchmark according to Macro Node B's DwPCH. Considering the complex deployment scenario of Home Node B networks, we advise Macro Node BS and Home Node B be deployed on different frequency band.

If Home Node B can detect multi Macro Node Bs' signal, it should select the best suitable macro cell from all candidate Macro Node Bs.

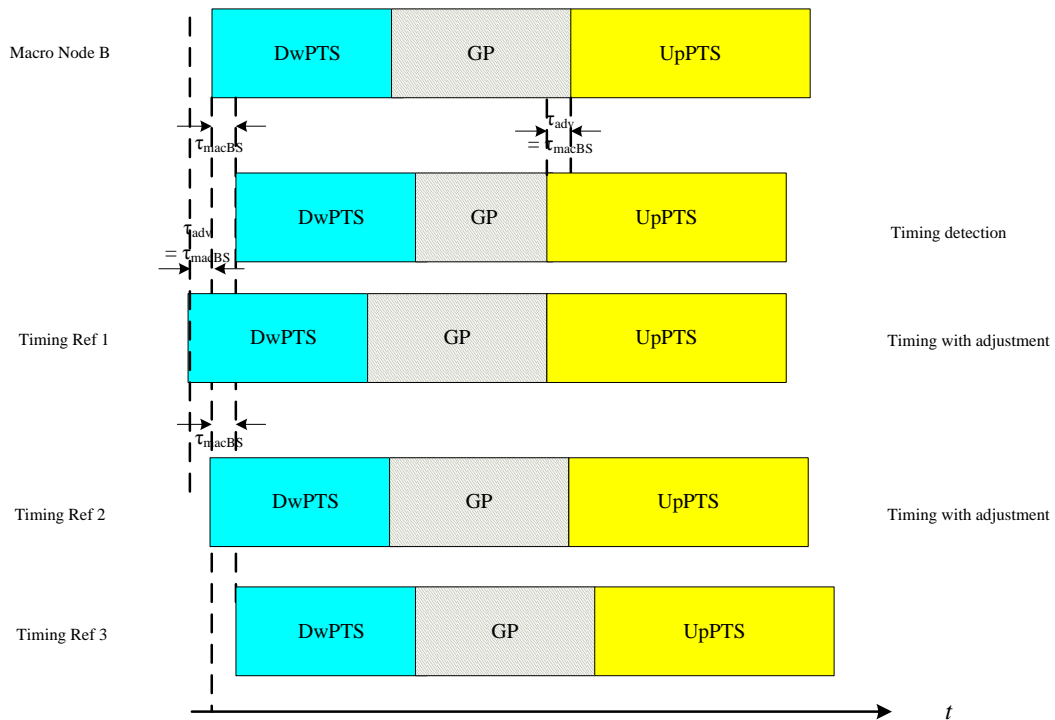

Figure 7.5.1-1: 1.28Mcps TDD Home NodeB Timing according to Macro Node B's DwPCH

Figure 7.5.1-1 gives three candidate 1.28Mcps TDD Home Node B air interface timing adjust methods:

- Reference 1: The frame boundary of Home Node B precedes anchored macro one with t_{adv} , which is given by macro Node B via a uplink synchronisation procedure;
- Reference 2: The frame boundary of Home Node B is exactly aligned with anchored macro one via uplink synchronisation procedure;
- Reference 3: Home Node B sets its frame boundary at the time point when it detects a downlink synchronisation peak, which in principle lags t_{adv} behind anchored macro one.

If reference 1 or 2 is selected, Home Node B shall behave as a regular 1.28Mcps TDD UE and perform a 'fake' random access in its synchronization.

If Home Node B can not detect Macro Node Bs' DwPCH, according to its SON characters, Home Node B should select one empty frequency that not occupied by its neighbour Home Node Bs.

- When Home Node B is power on, it should search the best suitable Home Node B from Home Node B available frequency list, and get its timing advance.
- Apply any type of Home Node B timing reference as shown in figure 1.

7.5.2 Periodic synchronization

Due to cost concern, Home NodeBs' oscillators with loose timing accuracy and stability requirement were preferred. Therefore 1.28Mcps TDD Home Node B needs to periodically perform a synchronisation corroboration to amend low stability problem to enable working frequency and timing accuracy.

On top of those detection rules elaborated above, Home NodeB will establish synchronization with the macro station at regular intervals. In the technical specification of 25.866, the description of frequency accuracy for Home NodeB is as follows:

Taking the conformance of frequency accuracy in the radio interface with the maximum mobility into account, the Home NodeB modulated carrier frequency can be relaxed to 0.25 PPM.

So the interval of periodical synchronization will become shorter. If the Home NodeB synchronizes with macro station so frequently, the Home NodeB needs to read the downlink signal often from macro station, it will affect the communication between the Home NodeB and UE in the coverage. So we propose the UE which works in the Home NodeB cell to measure the SFN-SFN observed time difference, and UE will report the measure result to Home NodeB, if the value of SFN-SFN observed time difference is bigger than predefined threshold, the Home NodeB will change the timing using this value.

SFN-SFN observed time difference is one of UE measurement abilities. It is the time difference of the reception times of frames from two cells (serving and target) measured in the UE and expressed in chips. It is distinguished by two types. Type 2 applies if the serving and the target cell have the same frame timing.

If there is any UE in the coverage of Home NodeB, a measure of SFN-SFN observed time difference will be configured by Home NodeB for this UE. UE performs the measurement periodically, and report it by event triggered or periodically. If the reporting is event triggered, the condition of reporting is the measurement value expires the predefined threshold. If the Home NodeB receives this measure report, the Home NodeB will change the timing of itself by this value. If the UE reports the measurement periodically, the Home NodeB will compare the measurement value to one predefined threshold, if the value is bigger than threshold, the Home NodeB will align it's timing using this reference.

If there is no UE in the Home NodeB cell, the Home NodeB will use the method depicted in section 2.1 to synchronize with macro station periodically.

8 Interference tests

8.1 Adjacent channel deployment

In TR 25.866[3], the adjacent channel deployment is found to work much better. At the early stage of Home NodeB deployment, the adjacent channel deployment is suggested for use. The purpose of the test is to ensure that a Home NodeB does not cause unacceptable interference to the adjacent channel operator. The Home NodeB can use measurements such as P-CCPCH RSCP and ISCP to adjust its transmit power such that it does not cause interference for the adjacent channel operator. The core requirements are specified in 25.105[4], corresponding test requirements is also specified in 25.142 R10.

8.2 Co-channel deployment

In order to ensure reasonable behaviour of Home NodeB and Macro NodeB, two scenarios are considered for Home NodeB deployments: a) cell edge and b) cell centre.

When Home NodeB is deployed at the cell edge, Macro UE transmits with maximum output power and it's reception power is lowest because of far distance. In this deployment, scenario 2(downlink) and scenario 3(uplink) are concerned interference scenarios.

When Home NodeB is deployed in the centre of cell, scenario 1(uplink) and scenario 4(downlink) are concerned interference scenarios.

To interference among Home NodeBs, it is suggested to consider 2 Home NodeBs and each Home NodeB only has one UE.

Detailed test cases are FFS.

Annex A: Change history

Change history							
Date	TSG #	TSG Doc.	CR	Rev	Subject/Comment	Old	New
2010-02	RAN4#54				TR created		0.1.0
2010-05	RAN4#54	R4-100490			Text Proposal on changes of transmitter of 1.28Mcps TDD Home NodeB in 25.105	0.1.0	0.2.0
		R4-100491			Text Proposal on Receiver of 1.28Mcps TDD Home NodeB in 25.105		
		R4-100492			Text Proposal on changes of performance of 1.28Mcps TDD Home NodeB in 25.105		
		R4-100493			Text Proposal on changes of transmitter of 1.28Mcps TDD Home NodeB in 25.142		
		R4-100494			Text Proposal on Receiver of 1.28Mcps TDD Home NodeB in 25.142		
		R4-100495			Text Proposal on changes of performance of 1.28Mcps TDD Home NodeB in 25.142		
2010-08	RAN4#55	R4-103079			3GPP TR 25.869 on 1.28Mcps TDD Home NodeB	0.2.0	0.3.0
2010-08	RAN4#55	R4-103080			TP on Interference mitigation method of 1.28Mcps TDD Home NodeB- Measurement test	0.3.0	0.4.0
		R4-103081			TP on Interference mitigation method of 1.28Mcps TDD Home NodeB- Control of output power of Home NodeB		
		R4-103082			TP on Interference mitigation method of 1.28Mcps TDD Home NodeB- AGC of Home NodeB		
		R4-103083			TP on Interference mitigation method of 1.28Mcps TDD Home NodeB- Self Configuration of Home NodeB		
		R4-103084			TP on Interference mitigation method of 1.28Mcps TDD Home NodeB- Synchronization		
2010-10	RAN4#57	R4-104021			TP on consideration of interference test of 1.28Mcps TDD Home NodeB	0.4.0	0.5.0
2010-12	RAN#50	RP-101166			Presented to RAN for Approval	0.5.0	1.0.0
2010-12	RAN#50	RP-101166			Approved by TSG RAN	1.0.0	10.0.0
2012-09	-	-	-	-	Update to Rel-11 version (MCC)	10.0.0	11.0.0