

3GPP TR 25.950 V4.0.1 (2005-07)

Technical Report

3rd Generation Partnership Project; Technical Specification Group Radio Access Network; UTRA High Speed Downlink Packet Access (Release 4)



The present document has been developed within the 3rd Generation Partnership Project (3GPPTM) and may be further elaborated for the purposes of 3GPP.

The present document has not been subject to any approval process by the 3GPP Organizational Partners and shall not be implemented. This Specification is provided for future development work within 3GPP only. The Organizational Partners accept no liability for any use of this Specification. Specifications and reports for implementation of the 3GPPTM system should be obtained via the 3GPP Organizational Partners' Publications Offices.

Keywords

UMTS, radio, packet mode

3GPP

Postal address

3GPP support office address

650 Route des Lucioles - Sophia Antipolis
Valbonne - FRANCE
Tel.: +33 4 92 94 42 00 Fax: +33 4 93 65 47 16

Internet

<http://www.3gpp.org>

Copyright Notification

No part may be reproduced except as authorized by written permission.
The copyright and the foregoing restriction extend to reproduction in all media.

© 2005, 3GPP Organizational Partners (ARIB, ATIS, CCSA, ETSI, TTA, TTC).
All rights reserved.

Contents

Foreword	5
1 Scope	6
2 References.....	6
3 Void.....	6
4 Background and Introduction	6
5 Overview of Techniques considered to support UTRA High Speed Downlink Packet Access.....	7
5.1 Adaptive modulation and Coding Schemes	7
5.2 SAW-Hybrid ARQ	7
5.3 Fast Cell Selection	8
5.4 Standalone DSCH.....	8
5.5 Multiple Input Multiple Output Antenna Processing	8
6 Basic structure of HS-DSCH.....	8
6.1 Architecture Issues	8
6.2 Protocol structure.....	9
6.3 Basic physical structure.....	9
6.3.1 HSDPA physical-layer structure in the code domain	10
6.3.2 HSDPA physical-layer structure in the time do main	11
6.4 Transport channel structure.....	11
6.5 Impact on Interfaces	11
6.6 Conclusions.....	11
7 Adaptive Modulation and Coding Schemes (AMCS).....	12
7.1 Technical Details	12
7.2 Performance Evaluation.....	12
7.3 Complexity Evaluation	12
7.4 Conclusions.....	13
8 SAW-Hybrid ARQ.....	13
8.1 Technical Details	13
8.1.1 Single Device Example	14
8.1.2 Multi-device Example	15
8.2 Proposals for further enhancement of N-channel SAW-HARQ.....	17
8.3 Enablers for Hybrid ARQ.....	17
8.4 Architectural Alternatives and Impact on Current Specifications	17
8.4.1 Existing Architecture	17
8.4.2 Distributed Architecture	17
8.4.3 MAC-HS-DSCH.....	18
8.5 Performance Evaluation.....	19
8.6 Complexity Evaluation	19
8.7 Conclusions.....	20
9 Fast Cell Selection	20
9.1 Principle	20
9.2 Description of different schemes.....	20
9.2.1 Intra-Node B FCS.....	20
9.2.2 Inter-Node B FCS.....	20
9.2.2.1 Queue Management	20
9.2.2.1.1 Option 1 - Over-The-Air Queue Management:.....	21
9.2.2.1.2 Option 2 - Network-Based Queue Management.....	21
9.2.2.2 Impact of inter-node FCS on HARQ	21
9.3 Potential benefit	21
9.4 Impact on Interfaces	21
9.5 Conclusions.....	22

10	Multiple Input Multiple Output Antenna Processing	22
10.1	Conclusions	22
11	Associated signalling needed for HS-DSCH operation for High Speed Downlink Packet Access	22
11.1	Associated Uplink signalling	22
11.1.1	Scheduling assistance information	22
11.1.2	SAW-HARQ	22
11.1.3	Fast Cell Selection	22
11.2	Associated Downlink signalling	23
11.2.1	Adaptive Modulation and Coding	23
11.2.2	SAW-HARQ	23
11.3	Conclusions	23
12	Standalone DSCH	23
12.1	Notion of standalone DSCH	23
12.2	Impacts on radio protocols	23
12.3	Impacts on UE	24
12.4	Coexistence with R99	24
12.5	Conclusions	24
13	System Simulation Results	24
13.1	HSDPA Baseline Performance (AMC, HARQ, FCS, Fast Scheduler, 3.33ms frame) vs. R99	24
13.2	Integrated Voice and Data Performance	24
14	Conclusions	25
14.1	Recommendations	26
Annex A: Change history		27

Foreword

This Technical Report has been produced by the 3rd Generation Partnership Project (3GPP).

The contents of the present document are subject to continuing work within the TSG and may change following formal TSG approval. Should the TSG modify the contents of the present document, it will be re-released by the TSG with an identifying change of release date and an increase in version number as follows:

Version x.y.z

where:

- x the first digit:
 - 1 presented to TSG for information;
 - 2 presented to TSG for approval;
 - 3 or greater indicates TSG approved document under change control.
- y the second digit is incremented for all changes of substance, i.e. technical enhancements, corrections, updates, etc.
- z the third digit is incremented when editorial only changes have been incorporated in the document.

1 Scope

The present document describes several techniques, which facilitate high-speed downlink packet access. Furthermore, it describes how these concepts should be integrated into the overall architecture of UTRA. The techniques should be applicable to streaming, interactive and background services.

2 References

The following documents contain provisions which, through reference in this text, constitute provisions of the present document.

- References are either specific (identified by date of publication, edition number, version number, etc.) or non-specific.
- For a specific reference, subsequent revisions do not apply.
- For a non-specific reference, the latest version applies. In the case of a reference to a 3GPP document (including a GSM document), a non-specific reference implicitly refers to the latest version of that document *in the same Release as the present document*.

- [1] 3GPP TR 25.848: "HSDPA RAN WG1 Feasibility Study report".
- [2] TSGR1#12(00) 0556, "Feasibility study of Advanced techniques for High Speed Downlink Packet Access", Motorola.
- [3] SMG2 UMTS L1 682/98, "Channel Bandwidth Allocation Strategy", Motorola.
- [4] Ghosh et al, "Performance of Coded Higher Order Modulation and Hybrid ARQ for Next Generation Cellular CDMA Systems", Vehicular Technology Conference Fall 2000, Sept 24th – 28th, 2000, Boston, Massachusetts, USA.
- [5] D. Bertsekas, R. Gallager, Data Networks Second Edition, Prentice Hall, Englewood Cliffs, New Jersey.
- [6] R2A010016: "Dual-Channel Stop-and-Wait HARQ", Motorola.
- [7] R2A010017: "Fast Cell Selection and Handovers in HSDPA", Motorola.
- [8] R2A010004: "Proposed way forward with HSDPA", Nokia.
- [9] R2A010002: "Support of standalone carrier for DSCH", Nortel.
- [10] R2A010021: "ARQ Technique for HSDPA", Lucent.
- [11] R2A010015: "HSDPA Signaling Requirements", Motorola.
- [12] R2-010493: "HSDPA Signalling requirements for TDD mode", Siemens.
- [13] R2A010010: "HSDPA Radio Interface Protocol Architecture ", Ericsson, Motorola.

3 Void

4 Background and Introduction

In RAN#7 plenary meeting a work item was approved for "Feasibility study for high speed downlink packet access". The work item is a feasibility study, where techniques like adaptive modulation and coding, hybrid ARQ and other

advanced features are discussed and evaluated with the goal to increase throughput, reduce delay and achieve high peak rates.

5 Overview of Techniques considered to support UTRA High Speed Downlink Packet Access

5.1 Adaptive modulation and Coding Schemes

In cellular communication systems, the quality of a signal received by a UE depends on number of factors —the distance between the desired and interfering base stations, path loss exponent, log-normal shadowing, short term Rayleigh fading and noise. In order to improve system capacity, peak data rate and coverage reliability, the signal transmitted to and by a particular user is modified to account for the signal quality variation through a process commonly referred to as link adaptation. Traditionally, CDMA systems have used fast power control as the preferred method for link adaptation. Recently, Adaptation Modulation and Coding (AMC) [2] have offered an alternative link adaptation method that promises to raise the overall system capacity. AMC provides the flexibility to match the modulation-coding scheme to the average channel conditions for each user. With AMC, the power of the transmitted signal is held constant over a frame interval, and the modulation and coding format is changed to match the current received signal quality or channel conditions. In a system with AMC, users close to the base station (BTS) are typically assigned higher order modulation with higher code rates (e.g. 64 QAM with $R=3/4$ turbo codes), but the modulation-order and/or code rate will decrease as the distance from BTS increases. AMC is most effective when combined with fat-pipe scheduling techniques such as those enabled by the Downlink Shared Channel. On top of the benefits attributed to fat-pipe multiplexing [3], AMC combined with time domain scheduling offers the opportunity to take advantage of short term variations in a UEs fading envelope so that a UE is always being served on a constructive fade.

5.2 SAW-Hybrid ARQ

H-ARQ is an implicit link adaptation technique. Whereas, in AMC explicit C/I measurements or similar measurements are used to set the modulation and coding format, in H-ARQ, link layer acknowledgements are used for re-transmission decisions. There are many schemes for implementing H-ARQ - Chase combining, Rate compatible Punctured Turbo codes and Incremental Redundancy. Incremental redundancy or H-ARQ-type-II is another implementation of the H-ARQ technique where in instead of sending simple repeats of the entire coded packet, additional redundant information is incrementally transmitted if the decoding fails on the first attempt.

H-ARQ-type-III also belongs to the class of incremental redundancy ARQ schemes. However, with H-ARQ-type-III, each retransmission is self-decodable which is not the case with H-ARQ-type II. Chase combining (also called H-ARQ-type-III with one redundancy version) involves the retransmission by the transmitter of the same coded data packet. The decoder at the receiver combines these multiple copies of the transmitted packet weighted by the received SNR. Diversity (time) gain is thus obtained. In the H-ARQ-type-III with multiple redundancy versions different puncture bits are used in each retransmission.

AMC by itself does provide some flexibility to choose an appropriate MCS for the channel conditions based on measurements either based on UE measurement reports or network determined. However, an accurate measurement is required and there is an effect of delay. Also, an ARQ mechanism is still required. H-ARQ autonomously adapts to the instantaneous channel conditions and is insensitive to the measurement error and delay. Combining AMC with H-ARQ leads to the best of both worlds - AMC provides the coarse data rate selection, while H-ARQ provides for fine data rate adjustment based on channel conditions.

The choice of H-ARQ mechanism however is important. There are two main ARQ mechanisms - selective repeat (SR) and stop-and-wait (SAW). In SR, only erroneous blocks are re-transmitted. A sequence number is required to identify the block. Typically, in order to fully utilize the available channel capacity the SR ARQ transmitter needs to send a number of blocks while awaiting a response (or lack of it in this case). Hence when combined with H-ARQ the mobile needs to store soft samples for each partially received block. Thus mobile memory requirements can be huge. More importantly, H-ARQ requires that the receiver must know the sequence number prior to combining separate re-transmissions. The sequence number must be encoded separately from the data and must be very reliable to overcome whatever errors the channel conditions have induced in the data. Hence a strong block code is needed to encode the sequence information - increasing the bandwidth required for signalling.

Stop-and-wait is one of the simplest forms of ARQ requiring very little overhead [5]. In stop-and-wait, the transmitter operates on the current block until the block has been received successfully. Protocol correctness is ensured with a simple one-bit sequence number that identifies the current or the next block. As a result, the control overhead is minimal. Acknowledgement overhead is also minimal, as the indication of a successful/unsuccessful decoding (using ACK, NACK, etc) may be signalled concisely with a single bit. Furthermore, because only a single block is in transit at a time, memory requirements at the UE are also minimized.

5.3 Fast Cell Selection

Fast Cell selection (FCS) has been proposed for HSDPA. Using FCS, the mobile indicates the best cell that should serve it on the downlink, through uplink signalling. Thus while multiple cells may be members of the active set, only one of them transmits at any time, potentially decreasing interference and increasing system capacity.

5.4 Standalone DSCH

A standalone DSCH is a DSCH on a downlink carrier that is different from the WCDMA carrier that carries its companion DPCH. As seen from R99, the DSCH provides for a downlink fat pipe that carries multiple terminals. It is proposed to study how R99 could be extended for the support of the concept of standalone DSCH through new modulations, optimised for mobile high bit rate data in downlink, defined for the standalone DSCH.

5.5 Multiple Input Multiple Output Antenna Processing

Diversity techniques based on the use of multiple downlink transmit antennas are well known; second order applications of these have been applied in the UTRA R99 specifications. Such techniques exploit spatial and/or polarisation decorrelations over multiple channels to achieve fading diversity gains.

Multiple input multiple output (MIMO) processing employs multiple antennas at both the base station transmitter and terminal receiver, providing several advantages over transmit diversity techniques with multiple antennas only at the transmitter and over conventional single antenna systems. If multiple antennas are available at both the transmitter and receiver, the peak throughput can be increased using a technique known as code re-use. With code re-use, each channelisation/scrambling code pair allocated for HS-DSCH transmission can modulate up to M distinct data streams, where M is the number of transmit antennas. Data streams which share the same channelisation/scrambling code must be distinguished based on their spatial characteristics, requiring a receiver with at least M antennas. In principle, the peak throughput with code re-use is M times the rate achievable with a single transmit antenna. Third, with code re-use, some intermediate data rates can be achieved with a combination of code re-use and smaller modulation constellations e.g. 16 QAM instead of 64 QAM. Compared to the single antenna transmission scheme with a larger modulation constellation to achieve the same rate, the code re-use technique may have a smaller required E_b/N_0 , resulting in overall improved system performance.

6 Basic structure of HS-DSCH

6.1 Architecture Issues

Two architectures have been considered as part of the study item: an RNC-based architecture consistent with R99 architecture and a Node B-based architecture for scheduling [13]. Moving the scheduling to the Node B enables a more efficient implementation of scheduling by allowing the scheduler to work with the most recent channel information. The scheduler can adapt the modulation to better match the current channel conditions and fading environment. Moreover, the scheduler can exploit the multi-user diversity by scheduling only those users in constructive fades. Furthermore, the HSDPA proposal has the additional potential to improve on the RNC-based HARQ architecture in both UE memory requirements and transmission delay [4]. It is proposed therefore to move the scheduling for the HSDPA channel to the Node B.

6.2 Protocol structure

Since the HSDPA functionality should be able to operate in an environment where certain cells are not updated with HSDPA functionality there is a need to as far as possible keep the R99 functional split between layers. Furthermore, since the HSDPA functionality is intended for transport of dedicated logical channels, it is logical to keep the layers above MAC intact from R99. Hence, the PDCP and RLC layers are proposed to be kept as is when using HSDPA functionality. This means that RLC can operate in either AM or UM mode (but not in TM mode due to ciphering) and PDCP can be configured to do header compression or not. Furthermore, transport channel type switching is feasible if the MAC layer has similar functional split in UTRAN as for R99, i.e. keeping MAC-d in S-RNC.

The new functionality of hybrid ARQ and HSDPA scheduling are proposed to be included in MAC. In UTRAN it is proposed to include them in a new entity called MAC HS-DSCH terminated in Node B. The transport channel that the HSDPA functionality will use is called HS-DSCH (High Speed Downlink Shared Channel). Hence, the MAC entity controlling the transport channel is called MAC HS-DSCH.

Furthermore, the physical layer will have to be updated with signalling support for hybrid ARQ and HS-DSCH scheduling. Figure 1 shows the proposed radio interface protocol architecture with termination points. MAC HS-DSCH in Node B is located below MAC-c/sh in CRNC. MAC-c/sh shall provide functions to HSDPA already included for DSCH in the R99 version of MAC-c/sh. Note that the HS-DSCH FP (frame protocol) will handle the data transport from SRNC to CRNC (if the Iur interface is involved) and between CRNC and the Node B.

The proposed architecture supports both FDD and TDD modes of operation, though in the case of TDD details of the associated signalling for HS-DSCH are different.

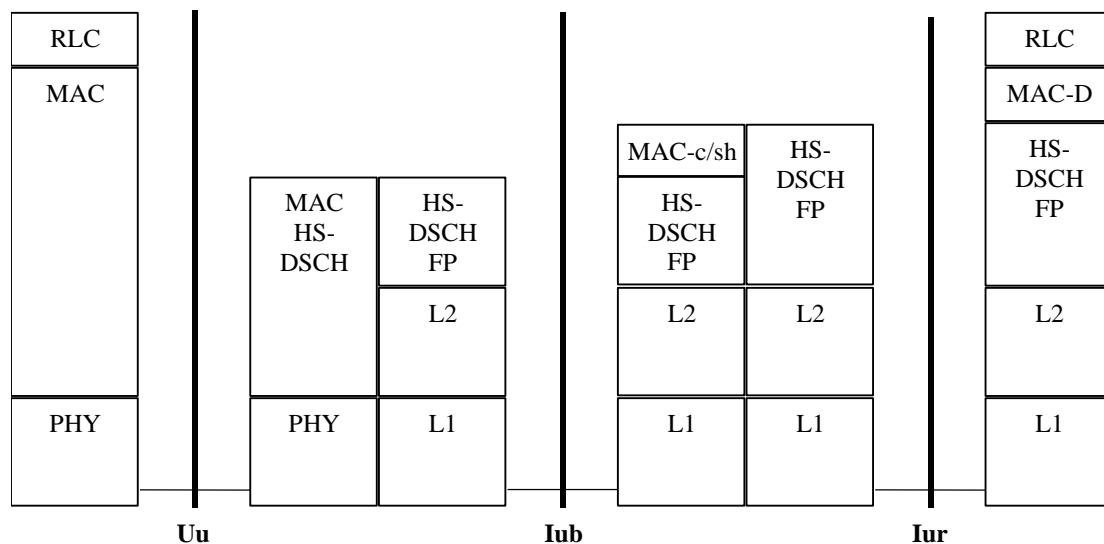

Figure 1: Radio Interface Protocol Architecture of HSDPA

6.3 Basic physical structure

A physical layer model of HS-DSCH is depicted in Figure 2 and Figure 3. Note that some of the details of this model are subject to discussions in TSG RAN WG1. In this document the model is shown for the purpose of completeness and understanding rather than being completely correct.

Figure 2 a) shows the DL network side with a HARQ coding, multiplexing and modulation entity. This entity is used to encode, multiplex and modulate the data according to the decisions taken by MAC HS-DSCH scheduling and priority entity. Furthermore, there is a HARQ info and scheduling info signalling entity in the physical layer, which handles the signalling of the decisions taken by MAC HS-DSCH in a similar manner as TFCI for the DCH case.

Figure 2 b) shows the corresponding receiver part in the UE. There is a HARQ info and scheduling info signalling entity that receives the necessary information for the HARQ decoding, de-multiplexing and demodulation entity.

Figure 3 b) shows the feedback configuration of the UE in support of the HS-DSCH. There is a feedback entity that is controlled by the MAC HS-DSCH. The feedback consists of HARQ info and scheduling assistance information (e.g.

channel quality estimate to support Modulation and Coding Scheme selection). The scheduling information feedback is used by the MAC HS-DSCH scheduling entity, whereas the HARQ info is used by the MAC HS-DSCH HARQ entity. The DCH is used to transfer UL traffic not necessary related to HS-DSCH.

Figure 3 a) shows the receiving side of the network for the feedback information.

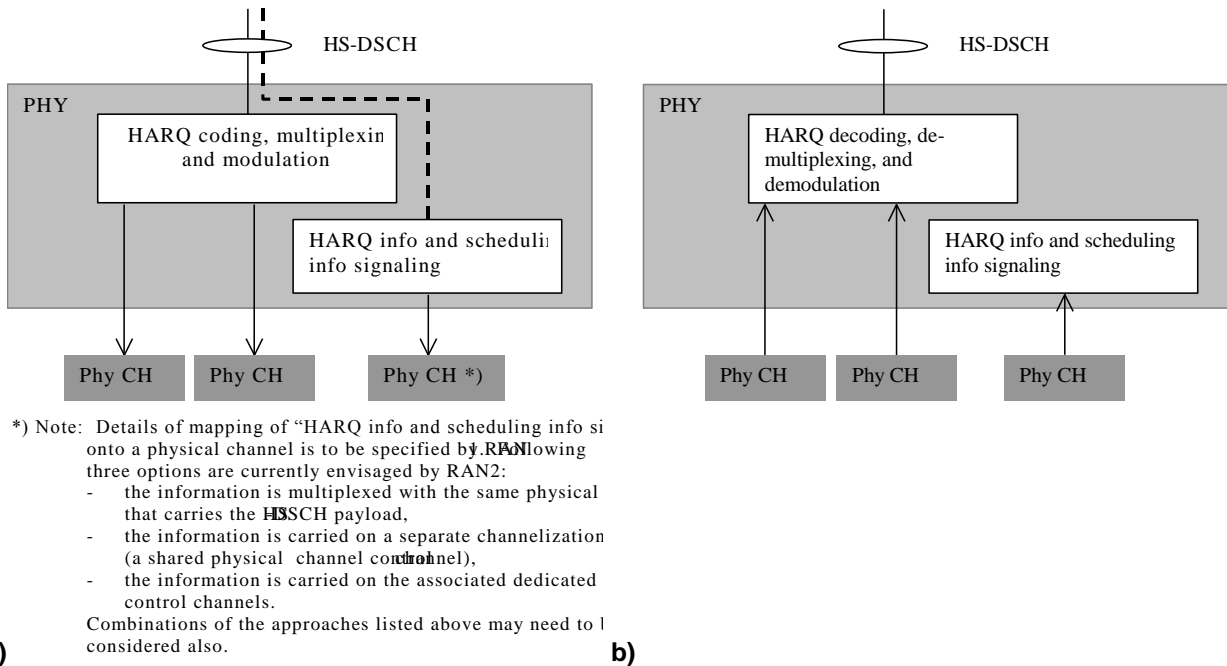

Figure 2: DL HS DSCH physical layer model, a) network side – b) UE side

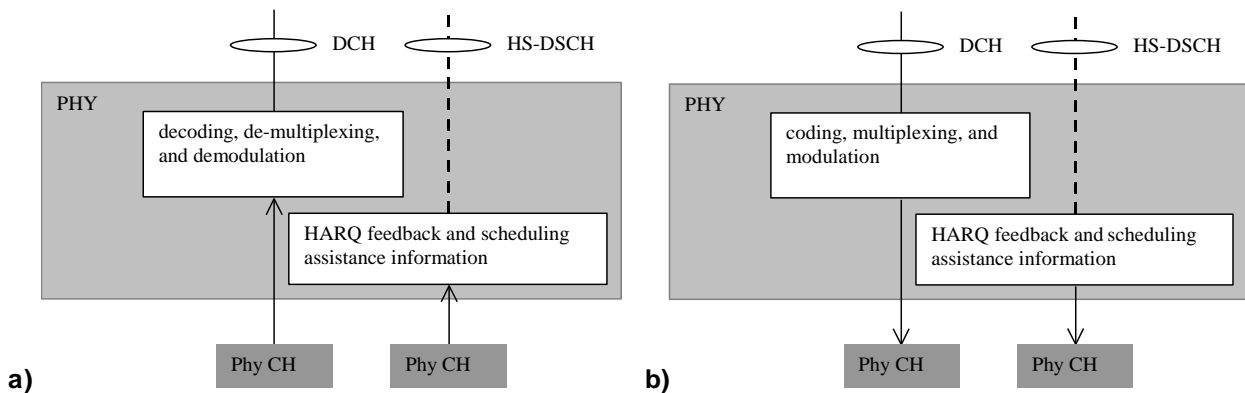

Figure 3: UL HS DSCH Physical Layer model, a) network side - b) UE side

On the physical layer, HSDPA transmission should be carried out on a set of downlink physical channels (codes) shared by users at least in the time domain and possibly also in the code domain.

6.3.1 HSDPA physical-layer structure in the code domain

In the code domain, it has been proposed that HSDPA transmission would use a fixed spreading factor and multi-code transmission. The selection of such a fixed HSDPA spreading factor should be based on an evaluation of the impact on

- Performance
- UE complexity
- Flexibility (granularity in the overall allocation of capacity for HSDPA transmission)

Considerations should also be made on to what possible extent there could be any additional flexibility advantages in supporting a variable spreading factor for HSDPA, and compare these with the impact on complexity etc.

6.3.2 HSDPA physical-layer structure in the time domain

In the time domain, the support of HSDPA TTI shorter than one radio frame (10 ms) has been proposed [2]. In addition there are proposals for variable TTI [10]. The length of such shorter HSDPA TTI should be selected from the set $\{T_{\text{slot}}, 3 \times T_{\text{slot}}, 5 \times T_{\text{slot}}, 15 \times T_{\text{slot}}\}$. The selection of such shorter HSDPA TTI and possibly variable TTI should be based on an evaluation of the impact on

- Performance
- Delay
- Network and UE complexity
- Flexibility (HSDPA payload granularity)

6.4 Transport channel structure

The HS-DSCH transport channel is characterised by the following:

- existence in downlink only;
- possibility to use beamforming;
- possibility of applying link adaptation techniques other than power control;
- possibility to be broadcast in the entire cell;
- always associated with another transport channel.

The following is a list of transport channel attributes:

1. Transport block size - dynamic
2. Transport block set size - dynamic for 1st transmission. Restriction for retransmission is for further study.
3. Transmission Time Interval(TTI) - for further study. There are two proposals - one considering fixed TTI size [2] and the other allowing for dynamic TTI size [10]. The possibility to use TTI as a semi-static parameter is also for further study.
4. Coding parameters
 - a. Type of error protection - fixed turbo coding
 - b. Coding rate - for further study
 - c. Rate matching parameters - for further study
5. Modulation - dynamic for 1st transmission. Restriction for retransmission is for further study.
6. Redundancy version - dynamic
7. CRC size - semi-static; additionally, there are two possibilities being considered - one wherein a CRC is attached to each TB and one wherein the CRC is per HSDPA frame.

6.5 Impact on Interfaces

At this stage, only the potential need for some additional requirements for flow control on the Iub has been identified. New configuration parameters on the Iub and Iur for defining the HS-DSCH would need to be identified.

6.6 Conclusions

RAN WG2 has determined the MAC-HSDSCH at the Node B with H-ARQ and scheduling functionality to be feasible and recommends that this be adopted for inclusion in Rel-5 to enable the techniques being addressed for HSDPA.

Further it should be noted that since the RLC entity continues to reside at the RNC as in R99, HSDPA can co-exist with R99 networks.

7 Adaptive Modulation and Coding Schemes (AMCS)

7.1 Technical Details

AMC is most effective when combined with fat-pipe scheduling techniques such as those enabled by the Downlink Shared Channel. On top of the benefits attributed to fat-pipe multiplexing, AMC combined with time domain scheduling offers the opportunity to take advantage of short term variations in a UE's fading envelope so that a UE is always being served on a constructive fade. Simulations suggest that for lower Doppler frequencies it is possible to schedule a user on a constructive fade provided that the scheduling interval (i.e. frame size) is small and the measurement reports are timely (scheduling at the edge). To take advantage of this technique, both a smaller frame size and scheduling at Node B have been proposed as part of the High Speed Downlink Packet Access (HSDPA) study item.

The implementation of AMC offers several challenges. First, AMC is sensitive to measurement error and delay. In order to select the appropriate modulation, the scheduler must be aware of the channel quality. Errors in the channel estimate will cause the scheduler to select the wrong data rate and either transmit at too high a power, wasting system capacity, or too low a power, raising the block error rate. Delay in reporting channel measurements also reduces the reliability of the channel quality estimate due to the constantly varying mobile channel. Furthermore changes in the interference add to the measurement errors. Hybrid ARQ (HARQ) enables the implementation of AMC by reducing the number of required MCS levels and the sensitivity to measurement error and traffic fluctuations.

There are different methods by which the HS-DSCH transport format (modulation and coding format) can be selected. These options are not mutually exclusive:

- a) The UE may estimate/predict the downlink channel quality and calculate a suitable transport format that is reported to the Node-B;
- b) The UE may estimate/predict the downlink channel quality and report this to the Node-B;
- c) Node-B may determine the transport format without feedback from the UE e.g. based on power control gain of the associated dedicated physical channel.

7.2 Performance Evaluation

For the HSDPA study item, an AMC scheme using 7 MCS levels were simulated using a symbol level link simulator. The AMC scheme uses QPSK, 8-PSK and 16 and 64 QAM modulation using $R=1/2$ and $R=3/4$ Turbo code. An equal average power scheduler was used when computing the analytical throughput. Detailed analytical throughput results with varying number of MCS levels and with Hybrid ARQ disabled/enabled are under different channel conditions can be found in [1]. To summarize, analytical simulations show that by using AMC with HARQ system throughputs as high as 2.775 Mbits/sector/carrier can be achieved with scheduling at the Node B compared to a throughput of 1.7 Mbits/sector/carrier using only QPSK, rate $1/2$ and scheduling at the Node B.

7.3 Complexity Evaluation

The Adaptive modulation and coding scheme applied on HS-DSCH may require UE to have following capabilities in addition to R99 UE functionality:

- Detection capability for MCS applied by Node-B
- Demodulation capability for higher order modulation
- Decoding capability for lower/higher rate turbo code
- Measurement/Reporting capability for downlink channel quality

A complexity evaluation of each of the above is presented in [1].

7.4 Conclusions

It has been seen through simulation results that a HS-DSCH with AMC and Hybrid ARQ can provide substantial higher peak rates and average throughput than the current Release-99 DSCH. The use of AMCS is feasible; however, demodulation of higher order modulations will lead to higher receiver complexity compared to a R99 UE. For an example, more refined synchronization tracking mechanism and more sophisticated channel estimation means may be required especially for 64QAM. Utilization of 64QAM may also require more advanced receiver techniques such as interference cancellers and equalizers. It may be noted that the performance of higher order modulation (e.g. 64 QAM), using more advanced receiver structures like MPIC has been studied in WG1 [1] with promising results. Finally, the performance of AMC could also be improved by using long-term prediction of the channel quality [1].

8 SAW-Hybrid ARQ

8.1 Technical Details

Hybrid ARQ can significantly increase user throughput over independent ARQ and FEC. In effect, Hybrid ARQ adapts to the channel by sending additional increments of redundancy, which decreases the overall coding rate and effectively lowers the data rate to match the channel (NOTE 1). In addition to improving throughput, Hybrid ARQ can be viewed as an enabler for adaptive modulation and coding (AMC). Hybrid ARQ makes AMC rate selection more robust because it does not rely on channel estimates to provide the correct code rate, but instead relies on the errors signalled by the ARQ protocol. However, Hybrid ARQ requires additional receiver memory to store unsuccessful attempts. As a result, Hybrid ARQ can significantly increase UE complexity depending on the ARQ protocol design and the network configuration.

NOTE 1: 'Hybrid ARQ' (or HARQ) is defined as any combined ARQ and FEC method that saves failed decoding attempts for future joint decoding. Hybrid ARQ therefore encompasses many named variants, such as code combining, Chase combining, incremental redundancy (IR), partial IR, full IR, type II HARQ, type III HARQ, etc, Dual-Channel Stop-and-Wait Hybrid ARQ applies to all forms of Hybrid ARQ.

Stop-and-wait (SAW) is one of the simplest forms of ARQ requiring very little overhead. In stop-and-wait, the transmitter operates on the current block until the block has been received successfully. Protocol correctness is ensured with a simple one-bit sequence number that identifies the current or the next block. As a result, the control overhead is minimal. Acknowledgement overhead is also minimal, as the indication of a successful/unsuccessful decoding (using ACK, NACK, etc) may be signalled concisely with a single bit. Furthermore, because only a single block is in transit at a time, memory requirements at the UE are also minimized. Therefore, HARQ using a stop-and-wait mechanism offers significant improvements by reducing the overall bandwidth required for signalling and the UE memory. However, one major drawback exists: acknowledgements are not instantaneous and therefore after every transmission, the transmitter must wait to receive the acknowledgement prior to transmitting the next block. This is a well-known problem with stop-and-wait ARQ. In the interim, the channel remains idle and system capacity goes wasted. In a slotted system, the feedback delay will waste at least half the system capacity while the transmitter is waiting for acknowledgments. As a result, at least every other timeslot must go idle even on an error free channel. Therefore, an ARQ method for Hybrid ARQ with the minimal complexity of stop-and-wait but with the throughput efficiency of SR is desired.

For HSDPA an N-channel SAW-HARQ implementation is being proposed. This can be viewed as a generalization of a dual channel HARQ implementation in which N=2.

Dual channel SAW-Hybrid ARQ offers a solution by parallelising the stop-and-wait protocol and in effect running a separate instantiation of the Hybrid ARQ protocol when the first channel is idle. As a result no system capacity goes wasted since one instance of the algorithm communicates a data block on the forward link at the same time that the other communicates an acknowledgment on the reverse link (NOTE 2).

NOTE 2: At first glance, dual-channel stop-and-wait may appear identical to SR with a window size of two. However, they are very different. Advancing a transmission window in SR requires that all blocks in the window have been transmitted successfully. A persistent failure in the transmission of one of the oldest blocks, early in the sequence, will prevent the ARQ window from advancing and prevent all communication on the channel. In dual-channel stop-and-wait, a persistent failure in one transmission block will only affect communication on one of the channels, allowing data transmission to continue on the other. Since the SR system must increase the window size in order to maintain an equivalent stall probability to dual-channel stop-and-wait, the SR system will require much more UE memory to achieve similar performance.

The dual channel SAW-HARQ places requirements both on the UE and the Network. Subclause 8.1.1 will examine the UE processing requirements by looking at transmissions to a single device. subclause 8.1.2 takes the devices described in subclause 8.1.1 and places them in a multi-user configuration to understand how the dual channel stop-and-wait concept works in a system.

8.1.1 Single Device Example

Figure 4 considers the case where a single user is using the channel. In Figure 4, the system consists of a single source and destination device over a slotted data channel. For this example, one slot is equivalent to one HSDPA TTI where it is assumed that all HSDPA TTIs are of the same size. The data channel is divided into even and odd timeslots to identify the independent instances of the Hybrid ARQ protocol. The even or odd state of the channel may be signalled explicitly on the control channel or derived globally from system information such as the CFN. The least significant bit of the CFN would be enough to identify the even or odd channel. Data blocks arrive from the network and are queued at the source. The source employs a dual channel sequencer to admit data blocks to either the even or odd transmitter. Once admitted, each transmitter performs a conventional stop-and-wait ARQ algorithm in its respective timeslot by transmitting the data block on the data channel and sequence bit on the associated control channel. Similar to the source, the destination device contains both an odd and even receiver, receiving blocks from the respective odd and even timeslots. Note, that these receivers are only a logical representation of a single hardware receiver. Each receiver is coupled with an independent Hybrid ARQ decoder. The Hybrid ARQ decoder signals the success (or failure) of the data block on a separate feedback channel. Both even and odd feedback channels exist to support each independent instance of the stop-and-wait.

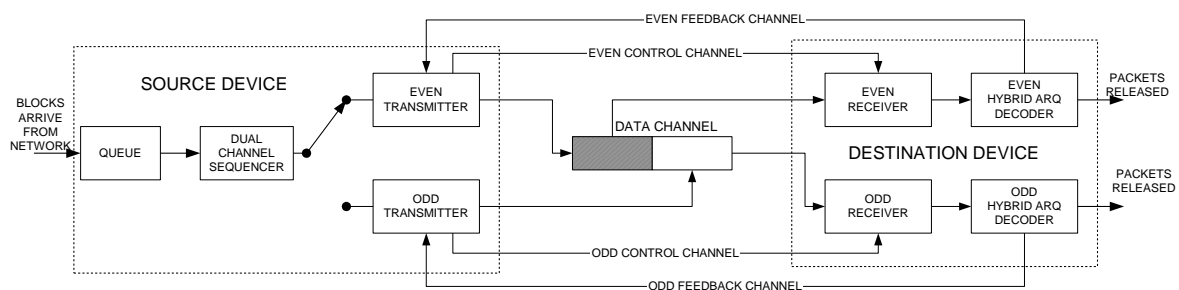

Figure 4: Single device block diagram.

In summary, this configuration requires:

- 1) A downlink slotted data channel.
- 2) A mechanism to associate each slot with either the even or the odd instance.
- 3) An even downlink control channel to identify the sequence number of the even stop-and-wait data PDU.
- 4) An odd downlink control channel to identify the sequence number of the odd stop-and-wait data PDU.
- 5) An even uplink feedback channel to signal either success or failure of the even downlink data channel.
- 6) An odd uplink feedback channel to signal either success or failure of the odd downlink data channel.

Figure 5 illustrates the timing of a dual channel stop-and-wait scheme showing how the even and odd data channels, control channels and feedback channels can be interleaved in time. In one slot, the even control and data are sent on the downlink while the odd feedback channel is sent on the uplink. In the next slot, the roles are reversed where the odd control and data are sent on the downlink while the even feedback channel is sent on the uplink.

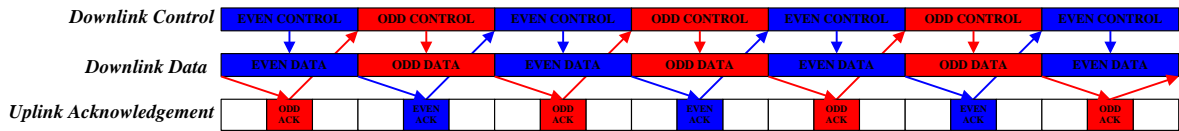

Figure 5: Timing of dual-channel stop-and-wait

In this single device example, the destination is required to maintain no more than two buffers of data (see NOTE), one for each instance of the stop-and-wait protocol. Timing depicted in Figure 5 suggests that the acknowledgment on the uplink channel does not occupy a complete slot allowing for processing of the downlink data by the destination device and processing of acknowledgements by the source device. In practice, it is possible to increase the processing times for both the source and destination devices by increasing the number of channels from 2 channels to N channels. As a result, the memory requirements at the destination devices would increase in proportion to the number of channels. Figure 6 and Figure 7 show the device and timing block diagrams, respectively, when the number of channels has been increased to four.

NOTE: At most two sets of buffers for some types of Hybrid ARQ, such as incremental redundancy.

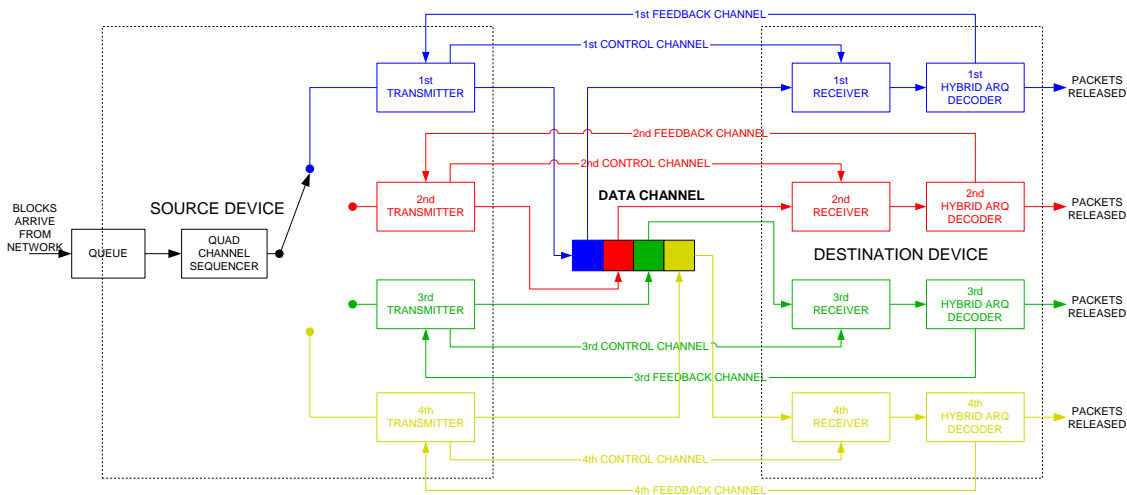

Figure 6: Single device example block diagram with quad channel stop-and-wait.

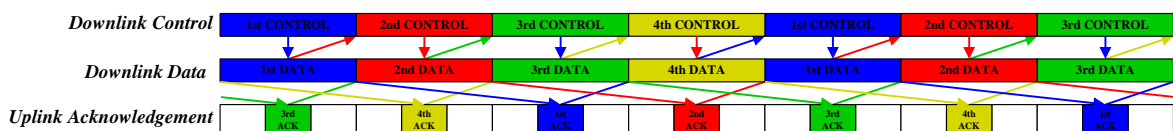

Figure 7: Timing of quad-channel stop-and-wait

8.1.2 Multi-device Example

Figure 8 extends the system described in subclause 8.1.1 to multiple sources and destinations. The source and destination devices are identical to Figure 6 and are coupled by independent downlink control and uplink feedback channels. Unlike Figure 6, all source and destination pairs share a single downlink data channel. Therefore, a system scheduler is required to arbitrate between the multiple sources in the system. The scheduler will select which source owns the current timeslot based on the status of each individual queue or possibly one large combined queue. In this case, each source must signal both the channel state, even or odd, and the ownership identity of the timeslot to the destination over the control channel. In particular, the presence of multiple devices allows the scheduler to defer retransmissions until a device is experiencing acceptable channel conditions, while maintaining full system utilization. In all other aspects, the system performs as in the single user case.

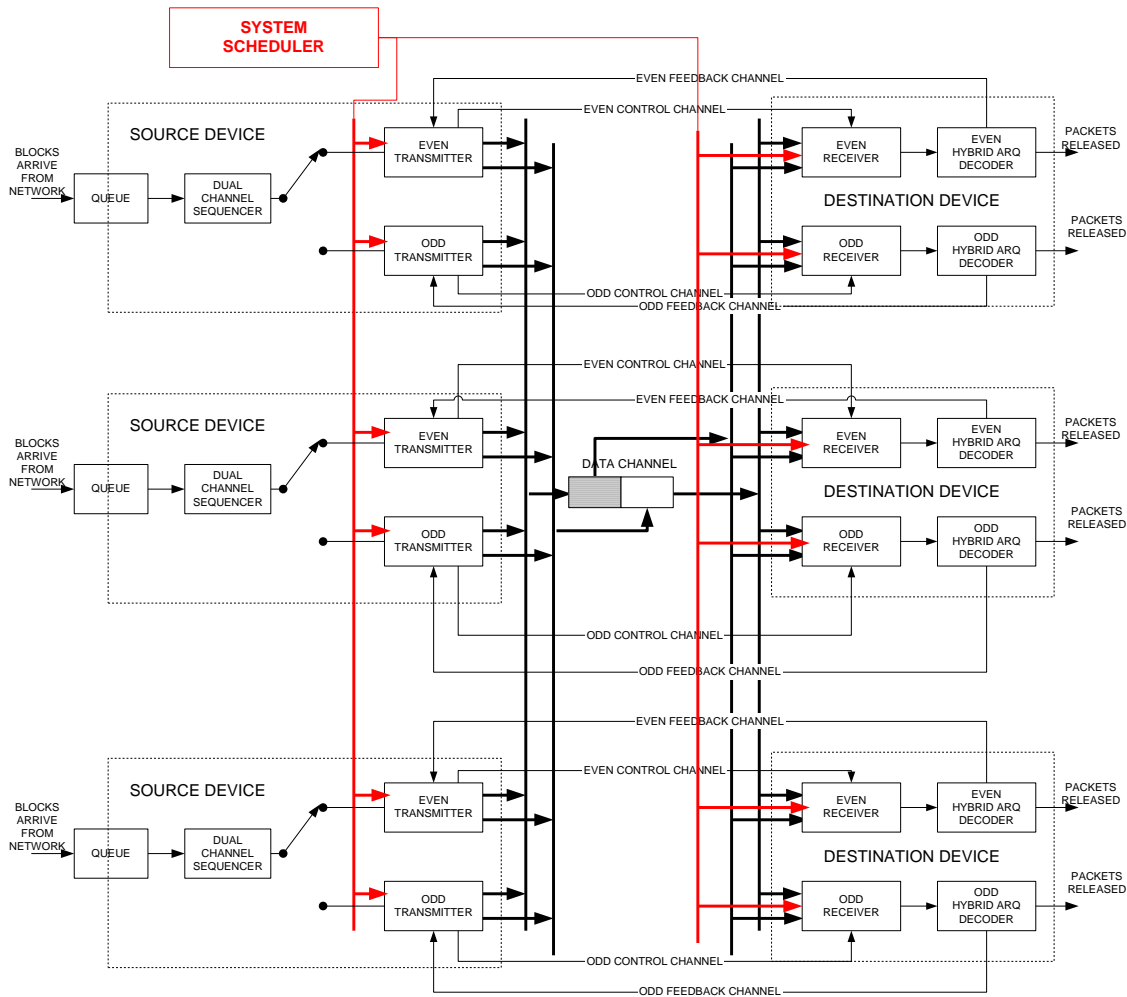

Figure 8: Multi-device/single data channel block diagram.

The multi-device example has nearly the identical requirements to the single device example. As before the following are required per device:

- 1) A downlink slotted data channel.
- 2) A mechanism to associate each slot with either the even or the odd instance.
- 3) An even downlink control channel to identify the sequence number of the even stop-and-wait data PDU.
- 4) An odd downlink control channel to identify the sequence number of the odd stop-and-wait data PDU.
- 5) An even uplink feedback channel to signal either success or failure of the even downlink data channel.
- 6) An odd uplink feedback channel to signal either success or failure of the odd downlink data channel.

In addition, the multi device example requires:

- 7) An addressing control channel from the system scheduler to each of the destination devices.

The stop-and-wait channels may be identified either implicitly or explicitly. *Implicit identification* would tie the even and odd channels instances to the cell-specific frame timing or CFN. However, if the TTI is less than 15 slots (i.e. one R99 frame) an offset counter into the frame will be necessary to identify the channel. The structure of the offset counter would depend on the TTI and number of channels. For example a TTI equal to 5 slots combined with 2 channel stop-and-wait protocol would require that the offset counter be reset every 30 slots or 20 ms to ensure an equal occurrence of each channel. Alternatively, a TTI equal to 5 slots combined with a 3 channel stop-and-wait protocol would allow the offset counter to be reset every 15 slots or 10 ms. In either case, the identification of the channel state would not require additional signalling. The number of channels and TTI could be determined a priori and maintained independently by the network and the UE.

Explicit identification would require that an additional field be added to the signalling channel to identify the channel state. This channel state field would only need to be sent when a data PDU was sent. The channel state field would be $\log_2 N$ bits where N represents the number of N -channel stop-and-wait ARQ.

8.2 Proposals for further enhancement of N-channel SAW-HARQ

Proposals have been submitted which claim to further enable the following:

- Flexibility of using either Chase combining or IR or a combination of both for both the 1st transmission and retransmission attempts.
- Transparent IR/combining operation across MIMO and non-MIMO implementations.
- Flexibility of selecting different transport block set sizes for same transport channel data rate (enabled by variable TTI).
- Changing MCS for retransmission attempts, even on fast cell switching.
- Early ACK feature - claimed to reduce transmission time and improve throughput in some cases.

8.3 Enablers for Hybrid ARQ

Two architectures can be considered as part of the study item: an RNC-based HARQ architecture consistent with R99 architecture and a Node B-based fast HARQ architecture as proposed for the HSDPA study item. The RNC-based architecture places significant burden on UE complexity by requiring the UE to store many soft samples for HARQ. A large RLC window size is necessary to accommodate the >100 ms Iub delay and ensure the maximum utilization of the channel. In order to take advantage of HARQ, the UE must have enough memory to store soft samples for all RLC PDUs within the window. This would amount to 10 times the memory that would be required by HARQ in an HSDPA-like architecture. In addition, the large Iub delay greatly increases the delay when using HARQ as link adaptation technique. For example, certain radio geometries require several retries to successfully decode a packet. In these cases, the RNC-based architecture may limit the types of services that take advantage of HARQ. As an illustration consider a radio geometry that requires 3 transmission attempts [4]. In an RNC-based, architecture the PDU would incur a 230 ms transmission delay (3 frames at 10 ms + 2 Iub delays at 100 ms). In contrast, a PDU transferred over a HSDPA architecture would require only 10.67 ms (3 frames at 3.33 ms + 2 Node B delays at 3.33 ms). A shorter frame size enables faster feedback on the HARQ transmission attempts while additionally providing the benefit of more granular scheduling assignments based on the latest channel conditions. Therefore, the HSDPA proposal has the additional potential to improve on the RNC-based HARQ architecture in both UE memory requirements and transmission delay through the choice of scheduling at the Node B and a shorter frame size.

8.4 Architectural Alternatives and Impact on Current Specifications

8.4.1 Existing Architecture

In R99 the scheduling is performed at the SRNC. Thus the MAC-d and RLC entities are located at the SRNC. If the HARQ functionality were to be similarly located at the SRNC, there would be a significant burden on the UE memory requirements.

8.4.2 Distributed Architecture

In UTRAN it is proposed to include the HARQ functionality in a new entity called MAC HS-DSCH terminated in Node B.

8.4.3 MAC-HS-DSCH

A more detailed model of the MAC layer for HS-DSCH can be based on the MAC models for MAC-d and MAC-c/sh in R99. Figure 9 shows a proposal of a MAC model for the UE side whereas Figure 10 shows a proposal for a MAC model for UTRAN side. The models show that both DCCH and DTCH can be transported using HSDPA technology. Furthermore, the MAC HS-DSCH entity in Node B, will have several HARQ entities (one for each associated MAC-d entity) whereas it includes only one scheduling priority entity, similar as MAC-c/sh for support of the DSCH. When HSDPA is employed, the MAC-c/sh entity as defined for the conventional DSCH is modelled as being divided into two parts. At the transmitting network side, MAC-c/sh provides flow control functionality between MAC-d and MAC-c/sh. Also in-band UE identification may be provided by MAC-c/sh for HS-DSCH, as is currently the case for DSCH. Note that it is for further study whether or not in-band UE identification should be applicable for HS-DSCH.

As permitted for the DSCH, MAC HS-DSCH may have the possibility to employ several HS-DSCH transport channels in parallel, which would be multiplexed on PHY onto a single Coded Composite Transport channel. It is for further study whether or not this concept of multiple HS-DSCH transport channels is useful, or whether a single HS-DSCH is sufficient.

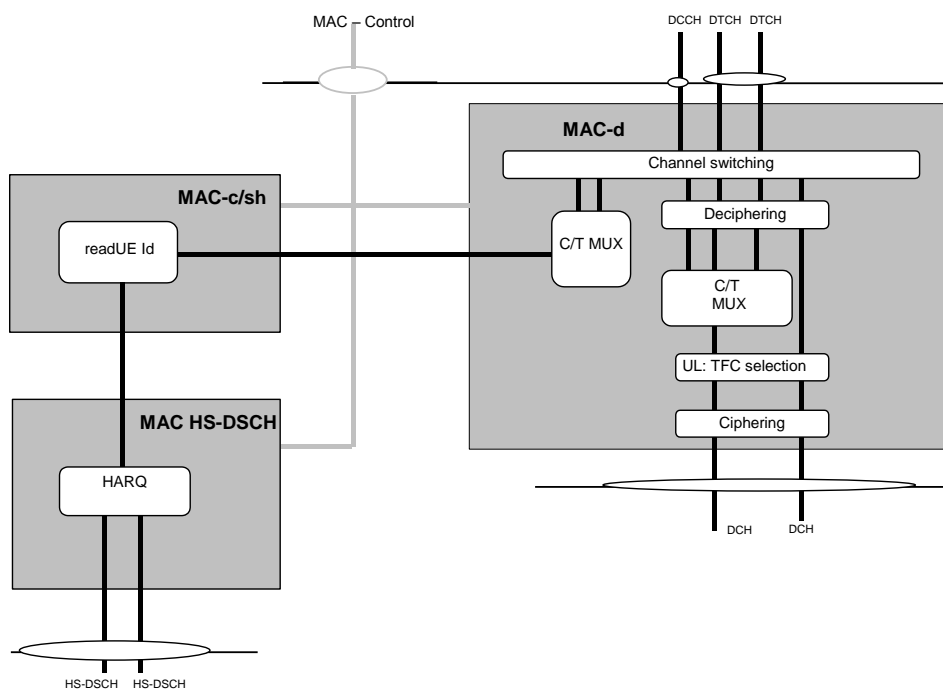

Figure 9: MAC model of HS-DSCH – UE side

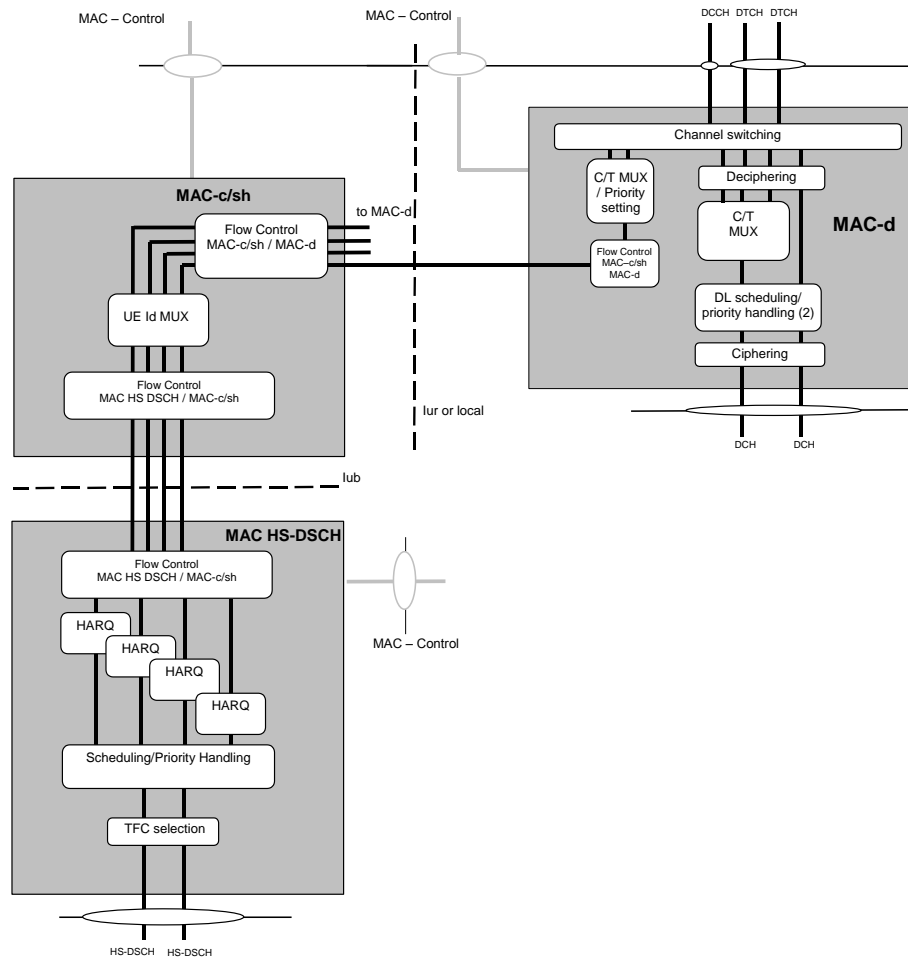

Figure 10: MAC model of HS DSCH – UTRAN side

8.5 Performance Evaluation

A detailed comparison of the performance of Chase combining, Partial IR and Full IR with three MCS levels using $R=3/4$ code and at various values of vehicle speeds can be found in [1]. The following is the summary of the conclusions

1. For QPSK, full IR benefits over Chase are not significant in the region of interest.
2. For higher order modulation the full IR provides more than 1dB gain in I_{or}/I_{oc} in a fading channel. However, the gain occurs in a region where a lower MCS may have been selected.
3. The decoder and signalling complexity of the full IR scheme over Chase combining needs to be evaluated, and weighed against the likelihood of the MCS selection process degrading to the point where a significant overall throughput gain is seen for the full IR.

The effect of CPICH SIR measurement errors (0, 1 and 3dB) on throughput with and without Hybrid ARQ (chase combining) is studied using a dynamic system simulation tool. With H-ARQ turned on, there is a drop in packet call throughput of between 5% and 10% with 1 dB CPICH measurement error. Sector throughput decreases by only about 5%. For 3dB CPICH measurement error, however, the packet call throughput drop approaches 50% and the sector throughput drop reaches 20%. More details on various results related to CPICH error and its effects on performance can be found in [1].

8.6 Complexity Evaluation

The complexity of H-ARQ mechanisms when employed for link adaptation in HSDPA transmission depends on the H-ARQ scheme selected as well as on where the retransmission functionality is located in the UTRAN. N-channel stop-

and-wait (SAW) protocol has been proposed as the retransmission functionality for HSDPA. A complexity evaluation on SAW H-ARQ dealing with buffering and encoding/decoding, rate matching complexities and complexity associated with UE and RNS processing times can be found in [1].

8.7 Conclusions

RAN WG2 has studied the various schemes presented for discussion for the H-ARQ feasibility study. The Stop-and-wait scheme is feasible. A H-ARQ mechanism minimizing mobile memory requirements is considered to be the preferable solution. Differences between different schemes such as Chase combining and IR have also been studied, but these differences do not justify that any scheme is discarded at this stage. However, care must be taken with regard to processing time. The effect of HSDPA TTI length and the number of HARQ sub-channels directly impact the available processing time in UE and RNS. Also as previously mentioned based on extensive simulations presented in WG1, it was observed that a HS-DSCH with AMC and Hybrid ARQ can provide substantial higher peak rates and average throughput than the current Release-99 DSCH.

9 Fast Cell Selection

9.1 Principle

Using FCS, the mobile indicates the best cell, which should serve it on the downlink, through uplink signalling. Thus while multiple cells may be members of the active set, only one of them transmits at any time, potentially decreasing interference and increasing system capacity. The mobile selects the best cell for transmitting on the downlink. It is proposed to have Layer 1 signalling (DPCCH) provide information to the cells in the active set (from hereon this shall be referred to as the "eligible set") as to which one is the best cell (the "serving cell") for DL transmission. The serving cell then decides the modulation and coding scheme to be used for the mobile and in addition may code multiple multiple mobiles within that HSDPA frame.

This is similar to the concept of SSDT of R99. However, there are some fundamental differences causing additional requirements that need to be addressed.

9.2 Description of different schemes

For HSDPA it is proposed to have scheduling at the Node B. Thus the identities and the number of packets the mobile is served with, is known to this cell only at this point. This leads to a synchronization issue on a subsequent change of serving cell when the new serving cell belongs to another Node B [7].

9.2.1 Intra-Node B FCS

One approach to this problem would be to limit the FCS to within a Node B, i.e. FCS is active within the cells of a single Node B. In this case the mobile would be limited to choosing cells of the current serving Node B. Any change in serving cell not in the current Node B, even if it were a member of the active set would require intervention from the RNC. This would occur through a handover mechanism. In this latter case, the issue of synchronization of the queues could be more easily accomplished through communication over the network interfaces.

9.2.2 Inter-Node B FCS

In this case the FCS mechanism is permitted over all cells of all Node Bs in the eligible set on a frame-by-frame basis. With scheduling moved to the Node B, there is a need for distributed queues if the concept of a non-singular active set (with cell membership spread across multiple Node Bs) is to be retained. Queue management then clearly is important. There are a number of options for management/synchronization of queues among the eligible set.

9.2.2.1 Queue Management

There are two primary methods for communication to manage the queues:

1. Over the air, with uplink signalling

2. Over the network

9.2.2.1.1 Option 1 - Over-The-Air Queue Management:

Here we can consider two further options -

- *Frame-by-Frame Update* - in this case the outcome of every singular transmission is communicated with the ACK on the uplink. Thus irrespective of the identity of the serving cell remaining constant or not, the uplink signalling channel is used to provide information to every eligible set member of the last transmission.
- *Event Based Update (Update on change of serving Node B)* - in this case, the state of the queues is communicated only on a FCS event leading to change of serving Node B (i.e. the new "serving cell" belongs to a different Node B than the current one). Thus the frame-by-frame ACK merely acknowledges the correct reception of a frame or lack thereof. Additional signalling is sent on the uplink to indicate the desire of change in serving Node B along with queue states. It will be necessary in this case for the UE to identify the membership of cells with respect to Node Bs in order to trigger the appropriate signalling.

9.2.2.1.2 Option 2 - Network-Based Queue Management

In this case, the state of the queues and the ARQ channels is transmitted to the eligible set members over the network Iub/Iur interfaces. This option however suffers from the obvious limitations due to interface delays.

It is believed that a good reliable mechanism would be a combination of both an over-the-air update and periodical network updates.

In both the above cases, it is important to consider options for the HARQ functionality. Particularly, it is essential to consider whether or not to permit the continuation of a HARQ transmission attempt or abort it on a FCS event.

9.2.2.2 Impact of inter-node FCS on HARQ

There are primarily two options in considering how FCS would manifest itself on the HARQ functionality:

- *Continue Option* - H-ARQ is continued (carried over to the new serving cell) after the FCS. Thus the new serving cell would need to retransmit packets if necessary using the same modulation and coding schemes used in the prior transmissions of the packet. This information then needs to be made available to the new serving cell using the ACK message on the uplink. If the uplink radio path is not of sufficient quality this message could be lost and the chosen serving cell would not then serve the mobile. If the message is received correctly then the newly chosen serving cell would have the necessary information - sequence number, modulation and coding scheme - in order to continue the HARQ attempt.
- *Abort Option* - All HARQ channels are aborted whenever a new serving cell is chosen. In this case, the newly chosen serving cell merely needs the sequence number of the packet it needs to transmit and if it has received the message indicating the choice of serving cell it would also have this information.

9.3 Potential benefit

Fast Cell Selection (FCS) improves throughput and residual FER for UEs in multi-coverage regions [1]. This is because a UE in a multi-coverage region typically has a weaker channel to any single serving cell compared to UEs closer to their serving cell. With FCS the multi-coverage UE has more opportunities to select a better link to one of the serving cells and be scheduled. The overall system benefit due to FCS is more significant with fair (in term of scheduling opportunities) schedulers (such as Round Robin) compared to maximum C/I scheduler since the users with weak links are scheduled more often. With a maximum C/I scheduler the larger the load the less impact FCS has on performance. Without FCS it takes longer for UEs with weak links to finish a packet call and hence longer to release the dedicated control channel which results in further overhead and reduced system capacity. Open issues include how much larger the FCS benefit is with motion and allowing for MCS changes between re-transmissions.

9.4 Impact on Interfaces

Fast Cell Selection is seen to have some impact on the Iub and Iur interfaces depending on which scheme is adopted. Impact is minimal in the case on Intra-Node B Fast Cell Selection.

9.5 Conclusions

Fast Cell selection has been discussed and concerns were expressed about the complexity associated with scheme involving inter-Node-B fast cell selection. FCS is primarily beneficial for Round-robin type scheduling and for users at the cell border. A phased implementation was discussed [8] for the different options for Fast Cell Selection and was seen as desirable depending on the benefit seen through simulations, with the first implementation involving only intra-Node B Fast Cell selections and subsequent implementations potentially incorporating inter Node-B FCS depending on benefits accruing from such a scheme. In addition it was seen that Fast Cell Selection could inherit a significant part of the required physical-layer functionality from SSDT. One identified approach is the possible use of physical-layer signalling to transfer transmission-state between Node B in case of inter-Node-B FCS.

10 Multiple Input Multiple Output Antenna Processing

Detailed simulation results can be found in [1]. In summary, simulations show that in a static environment MIMO has potential for increasing the data rate by a factor of 4 using a 4x4 configuration.

10.1 Conclusions

WG2 sees minimal impacts to L2/3 specifications at this stage, based on presentations in WG2, stemming from MIMO.

The goal of HS-DSCH is to increase the average throughput as well as the peak data rate. MIMO represents a promising approach but there are a wide variety of applicable MIMO techniques, which should be investigated along with MIMO examples in the TR during the standardisation process. It may also be noted that, the performance advantage of MIMO schemes is heavily dependent on the underlying channel model. The channel model should be agreed upon in RAN WG1 and will be used to verify different techniques.

11 Associated signalling needed for HS-DSCH operation for High Speed Downlink Packet Access

The following is an outline of the signalling requirement of HSDPA identifying the key parameters that must be communicated by the MAC-HS-DSCH [11]. The final configuration of the HS-DSCH channel may require additional fields and perhaps obviate some the fields identified.

MAC-HS-DSCH architecture is the same for FDD and TDD, though details of the associated signalling and the realization may be different. One approach, as an example, for the associated signalling in TDD would be to define separate signalling channels in downlink and uplink terminating in Node B [12].

11.1 Associated Uplink signalling

11.1.1 Scheduling assistance information

In order to support AMC and scheduling, feedback from the UEs may be required. Examples of this could be explicit channel quality estimate.

11.1.2 SAW-HARQ

The use of SAW-HARQ requires acknowledgement signalling from the UE receiving data through the HS-DSCH. At least one bit per frame is required as an ACK/NAK indicator if N-Channel Stop-and-Wait ARQ is used.

11.1.3 Fast Cell Selection

The support of FCS requires feedback signalling similar to SSDT from the UE. Inter-Node B fast cell selection may require additional uplink signalling in order to synchronize the states of the transmission queue in the new Node B and a new slot format for the DPCCH is probably necessary.

11.2 Associated Downlink signalling

11.2.1 Adaptive Modulation and Coding

In order to support AMC, it is necessary to inform the UE which MCS that has been used on the HS-DSCH. If code multiplexing is supported, additional bits are required to indicate which part of the code tree has been assigned to the UE in question.

Other fields may be required to support AMC. One example is gain setting to aid the demodulation of higher order modulation such as 16 QAM. This gain setting would identify the power allocated to HS-DSCH relative the CPICH.

11.2.2 SAW-HARQ

The support of SAW-HARQ requires the signalling of a sequence number. For the case of n-channel stop-and-wait HARQ, at least a 1-bit sequence number is required per HS-DSCH frame. In addition it is necessary to either implicitly or explicitly identify the stop-and-wait channels.

Additional signalling fields may be necessary to control the HARQ protocol. For example, incremental redundancy will require additional bits to identify the particular encoding format of the current HARQ attempt. Likewise, a mechanism for aborting the current ARQ attempt may be needed to limit the maximum number of attempts per frame and instruct the UE to flush the previous attempts from its receiver's buffers.

11.3 Conclusions

The necessary physical layer signalling and layer 2 signalling needed to support the various techniques for HSDPA are seen to be feasible. It was observed that physical layer signalling would play a significant role in enabling HSDPA techniques due to the fast feedback necessary for maximizing the benefits from the AMC and HARQ.

12 Standalone DSCH

12.1 Notion of standalone DSCH

A standalone DSCH is a DSCH on a downlink carrier that is different from the WCDMA carrier that carries its companion DPCH [9].

It is foreseen that the concept of the standalone DSCH is compatible with any of the HS-DSCH architecture proposed in this TR.

It is up to RAN WG1 to study the physical layer aspects of the standalone DSCH. New modulations, optimised for mobile high bit rate data in downlink, could be defined.

The standalone DSCH solution has the following characteristics:

- No fast power control
- Potential to introduce new modulation schemes
- No need for HARQ

12.2 Impacts on radio protocols

The R99 architecture is already suitable for the support of a standalone DSCH. Protocols have to be extended for the support of standalone DSCHs, but this seems fairly limited.

12.3 Impacts on UE

A standalone receiver for the additional carrier is needed. This receiver is dedicated to the reception of the high bit rate data in the downlink, and is part of the UE capability.

It is up to RAN WG1 and RAN WG4 to investigate impacts on the complexity in detail.

12.4 Coexistence with R99

There is no need to modify the DPCH, which is the companion to the standalone DSCH. The DSCH carrier is separated from the carrier carrying the associated DPCH. Therefore introduction of the standalone DSCH carrier in a R99 network would not lead to impact on the support of the UEs, which do not support the standalone DSCH. Also, it should be noted that the standalone DSCH could easily co-exist with the R99 DSCH. It could even be supported simultaneously in a single UE.

12.5 Conclusions

The stand-alone DSCH could reuse the R99 protocol architecture above the physical layer, but would allow the consideration of physical layer processing schemes different from the ones used in R99. RAN WG1 identified that the stand-alone DSCH was a specific case of mapping of transport channels for a UE in a multi-carrier cell. The feasibility, including aspects of coexistence and compatibility with UTRA R99 physical channels needs to be addressed.

13 System Simulation Results

See [1] for details on simulation assumptions and results. Below is a summary of the results of the simulations.

13.1 HSDPA Baseline Performance (AMC, HARQ, FCS, Fast Scheduler, 3.33ms frame) vs. R99

The detailed packet data throughput simulations for best effort service can be found in [1]. Best effort packet data average sector service throughput for a data-only HSDPA system with 30% overhead using a maximum C/I scheduler was shown to about 2.7Mbit/s based on quasi-static system simulations. A single ray 3kph Rayleigh faded channel was modelled for each user. At this load level up to 38% of the users in the system still achieved a packet call throughput exceeding 1Mbit/s and less than 10% achieved throughput below 32kbit/s. It may also be noted that HSDPA has twice the throughput of the R99 WCDMA throughput.

13.2 Integrated Voice and Data Performance

Sector data throughput of an integrated voice and High Speed Downlink Packet Access (HSDPA) system is investigated using the analytical-simulation approach described in [1]. The approach is to integrate the data throughput characteristic (Throughput (x)) in Equation 1 below obtained from link level simulations [1] for a given channel condition with the achievable carrier to interference ratio (C/I (x)) obtained from system simulation for the coverage area of several representative sectors of the voice & data system.

$$\text{Equation 1} \quad \text{AveSectorThroughput} = \int_{-20}^{20} \text{Throughput}(x) * P(x) * dx$$

The predicted sector throughput is therefore calculated from a combination of link level and system simulations. The system is assumed to be 100% loaded resulting in the base transceivers having a constant 100% linear power amp (LPA) load of 17 Watts. By always transmitting with constant power (17 Watts in this case) the voice users will not see abrupt changes in interference levels as the available power margin is allocated to data. Of the LPA load, up to 70% of the power can be allocated to the data channel constructed from up to 20 (or 28) multicodes with spreading factor 32 depending on the voice users (12.2kbit/s) loading. The other 30% of the LPA load is allocated to overhead channels (such as pilot (CPICH), paging (PICH), synchronization (SCH), etc.) and dedicated control channels. For FRP (Fractional recovered power due to delay spread)=0.98 and 20 codes the achieved Data only Throughput is about

2.5Mbit/s which then drops almost linearly as voice Erlangs per sector increases. For a voice user (12.2kbit/s) load of about 35 Erlangs/sector the Data 'equal power' sector throughput is still about 1Mbit/s.

High data sector throughput is maintained by simply allocating the available power margin in to data users. This approach is effective as long as the delay from measuring C/I and scheduling for a given user is small. Also the less slots (power control updates) a HSDPA frame encompasses the less margin needs to be set aside for voice users to guarantee them a minimum performance level during a scheduled burst. Alternatively, the power control rate for voice users could be reduced to 500Hz to minimize the power margin needed for voice users over a data frame interval such as 3.33ms.

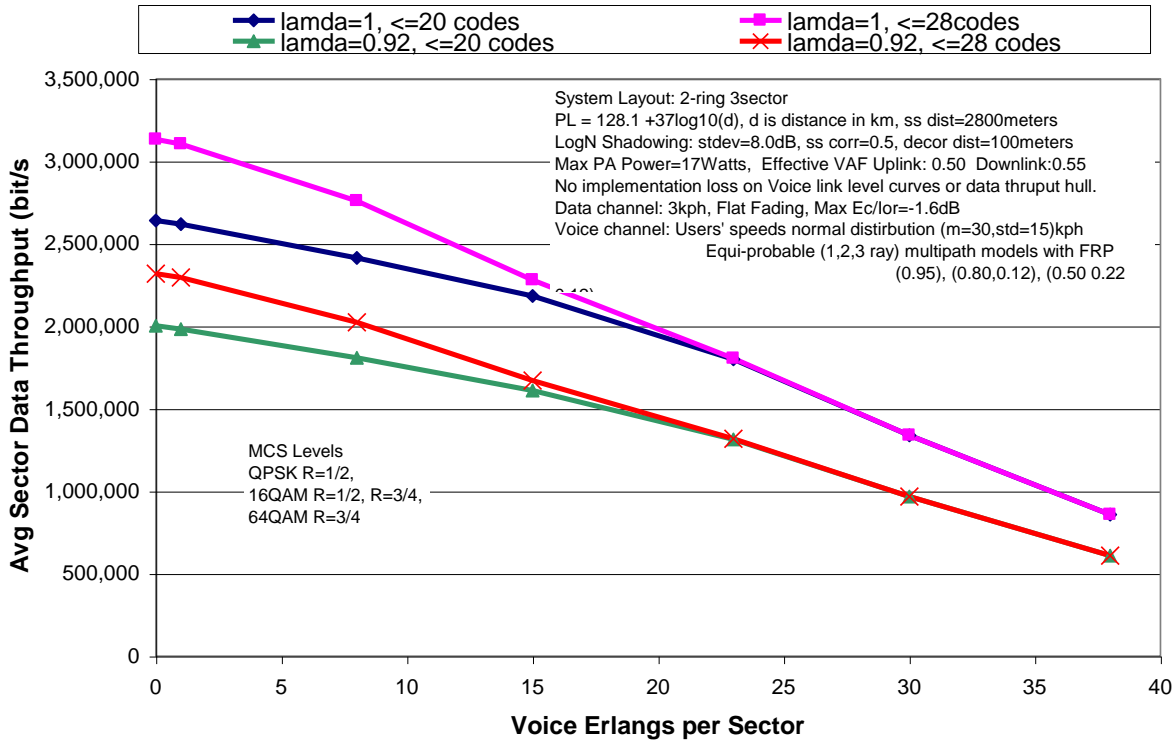

Figure 1: HSDPA Throughput vs. Voice Loading for different FRP (lambda) and for 20 and 28 OVSF codes where and Equal Average Power Scheduler is assumed.

14 Conclusions

In the HSDPA feasibility study the following techniques were proposed for consideration in RAN WG1 and WG2 -

- Adaptive Modulation and Coding
- Hybrid ARQ
- Scheduling at the Node B
- Fast Cell Selection
- Multiple Input Multiple Output (MIMO) Antenna techniques
- Stand-alone DSCH

Simulation results presented in RAN WG1 have demonstrated the potential of Adaptive Modulation and Coding, Hybrid ARQ, Scheduling at Node B and Fast Cell selection and MIMO. Each of these techniques is seen to be feasible, although concerns were expressed about the RF complexity of MIMO.

In particular it has been demonstrated that significant improvement in throughput and peak rates, and decrease in delay can be obtained through the application of Adaptive Modulation and Coding and H-ARQ along with scheduling at the Node B. Scheduling at the Node B is seen to be essential in order to maximize the benefits obtained through adaptive modulation and coding and H-ARQ.

In order to facilitate the introduction of AMC and HARQ with the aim of maximizing throughput and peak rates, a protocol architecture for the HS-DSCH has been proposed. The proposal envisages the introduction of a MAC-HSDSCH entity resident in the Node B to handle the functionality of HARQ and scheduling of the HS-DSCH.

A stand-alone DSCH on a separate carrier was also proposed as another technique for the HSDPA study item. In this case the feasibility, including aspects of coexistence and compatibility with UTRA R99 physical channels need to be addressed.

14.1 Recommendations

1. RAN WG2 has determined the MAC-HSDSCH at the Node B with HARQ and scheduling functionality to be feasible and recommends that this be adopted for inclusion in Rel-5 to enable the techniques being addressed for HSDPA.
2. Adaptive Modulation and Coding - RAN WG1 concluded that AMC (with HARQ) should be part of Release 5 HS-DSCH.
3. RAN WG1 recommends that the study of intra-Node B and inter-Node B Fast Cell Selection should be considered together and not separately. RAN WG1 recommends that both intra and inter Node-B FCS should be studied further in Rel-5 so that it can be a part of Rel-6 specification. RAN WG2 proposes not to include inter-Node B fast cell selection in Rel-5.
4. RAN WG1 recommends that MIMO should be part of further HSDPA study work. RAN2 has determined impacts on WG2 to be minimal based on current understanding.
5. RAN WG2 recommends that UTRAN evolution should enable the introduction of this technique if found necessary in future releases. If a work item on multi-carrier cells was to be considered at RAN, RAN WG1 recommends that a study item parallel to HSDPA be introduced to study the benefits of stand-alone DSCH for HSDPA as part of the UTRAN evolution.

Annex A: Change history

Change history							
Date	TSG #	TSG Doc.	CR	Rev	Subject/Comment	Old	New
03/2001	RP-11	RP-010050	-		Approved at TSG-RAN #11 and placed under Change Control	-	4.0.0
07/2005					Fix Word file compatibility problem (Word 2000 -> 2003).	4.0.0	4.0.1