

3GPP TR 25.945 V5.2.0 (2007-03)

Technical Report

3rd Generation Partnership Project; Technical Specification Group Radio Access Networks; RF requirements for 1,28 Mcps UTRA TDD option (Release 5)



The present document has been developed within the 3rd Generation Partnership Project (3GPP™) and may be further elaborated for the purposes of 3GPP.

The present document has not been subject to any approval process by the 3GPP Organizational Partners and shall not be implemented. This Specification is provided for future development work within 3GPP only. The Organizational Partners accept no liability for any use of this Specification. Specifications and reports for implementation of the 3GPP™ system should be obtained via the 3GPP Organizational Partners' Publications Offices.

Keywords

UMTS, radio

3GPP

Postal address

3GPP support office address

650 Route des Lucioles - Sophia Antipolis
Valbonne - FRANCE
Tel.: +33 4 92 94 42 00 Fax: +33 4 93 65 47 16

Internet

<http://www.3gpp.org>

Copyright Notification

No part may be reproduced except as authorized by written permission.
The copyright and the foregoing restriction extend to reproduction in all media.

© 2007, 3GPP Organizational Partners (ARIB, CCSA, ETSI, T1, TTA, TTC).
All rights reserved.

Contents

| | | |
|-------------|------------------------------------------------------------------------------|----|
| 1 | Scope | 18 |
| 2 | References..... | 18 |
| 3 | Abbreviations | 19 |
| 4 | RF Parameters in Support of Radio Resource Management..... | 19 |
| 4.1 | Idle Mode..... | 19 |
| 4.1.1 | Cell Selection | 19 |
| 4.1.1.1 | Introduction..... | 19 |
| 4.1.2 | Cell Re-Selection..... | 19 |
| 4.1.2.1 | Introduction..... | 19 |
| 4.1.2.2 | Requirements | 19 |
| 4.1.2.2.1 | Measurement and evaluation of cell selection criteria S of serving cell..... | 19 |
| 4.1.2.2.2 | Measurement of intra-frequency cells | 19 |
| 4.1.2.2.3 | Measurement of 1.28 Mcps TDD inter-frequency cells..... | 20 |
| 4.1.2.3 | High Chip Rate TDD re-selection..... | 20 |
| 4.1.2.4 | FDD Cell re-selection | 20 |
| 4.1.3 | Measurement of inter-RAT GSM cells | 21 |
| 4.1.4 | Evaluation of cell reselection criteria | 21 |
| 4.1.5 | Maximum interruption time in paging reception | 21 |
| 4.1.6 | Numbers of cells in neighbouring cell list | 22 |
| 4.2 | Connected Mode..... | 22 |
| 4.2.1 | TDD/TDD Handover..... | 22 |
| 4.2.1.1 | Introduction..... | 22 |
| 4.2.1.2 | Requirements | 22 |
| 4.2.1.2.1 | Handover delay | 23 |
| 4.2.1.2.2 | Interruption time | 23 |
| 4.2.2 | 1.28 Mcps TDD/FDD Handover | 23 |
| 4.2.2.1 | Introduction..... | 23 |
| 4.2.2.2 | Requirements | 23 |
| 4.2.2.2.1 | Handover delay | 23 |
| 4.2.2.2.2 | Interruption time | 24 |
| 4.2.3 | 1.28 Mcps TDD/GSM Handover | 24 |
| 4.2.3.1 | Introduction..... | 24 |
| 4.2.3.2 | Requirements | 24 |
| 4.2.3.2.1 | Handover delay | 24 |
| 4.2.3.2.2 | Interruption time | 25 |
| 4.2.4 | Cell Re-selection in CELL_FACH | 25 |
| 4.2.4.1 | Introduction..... | 25 |
| 4.2.4.2 | Requirements | 25 |
| 4.2.4.2.1 | Cell re-selection delay | 25 |
| 4.2.4.2.1.1 | All cells in the neighbour list belong to the same frequency | 25 |
| 4.2.4.2.1.2 | The cells in the neighbour list belong to different frequencies..... | 25 |
| 4.2.5 | Cell Re-selection in CELL_PCH..... | 26 |
| 4.2.5.1 | Introduction..... | 26 |
| 4.2.5.2 | Requirements | 26 |
| 4.2.6 | Cell Re-selection in URA_PCH | 26 |
| 4.2.6.1 | Introduction..... | 26 |
| 4.2.6.2 | Requirements | 26 |
| 4.3 | Dynamic Channel Allocation | 26 |
| 4.3.1 | Introduction..... | 26 |
| 4.3.2 | Implementation Requirements | 26 |
| 4.3.3 | Number of timeslots to be measured | 26 |
| 4.3.3.1 | Explanation | 26 |
| 4.3.4 | Measurement reporting delay..... | 26 |
| 4.4 | Timing characteristics | 27 |
| 4.4.1 | Timing Advance (TA) Requirements | 27 |

| | | |
|---------------|-----------------------------------------------------------------------------------|----|
| 4.4.1.1 | Uplink synchronization control requirements for UE for 1.28 Mcps TDD option | 27 |
| 4.4.1.1.1 | Uplink synchronization control steps | 27 |
| 4.4.1.1.2 | Timing Advance (T_{ADV}) for 1.28 Mcps TDD | 27 |
| 4.4.1.1.2.1 | Accuracy requirements | 27 |
| 4.4.1.1.2.2 | Range/mapping | 27 |
| 4.4.1.1.2.2.1 | Explanation difference | 28 |
| 4.4.2 | Cell synchronisation accuracy | 28 |
| 4.4.2.0 | Explanation | 28 |
| 4.4.2.1 | Definition | 28 |
| 4.4.2.2 | Minimum Requirements | 28 |
| 4.5 | UE Measurements Procedures | 28 |
| 4.5.1 | Measurements in CELL_DCH State | 28 |
| 4.5.1.0 | Explanation | 28 |
| 4.5.1.1 | Introduction | 29 |
| 4.5.1.2 | Requirements | 29 |
| 4.5.2 | Measurements in CELL_FACH State | 29 |
| 4.5.2.0 | Explanation | 29 |
| 4.5.2.1 | Introduction | 29 |
| 4.5.2.2 | Requirements | 29 |
| 4.6 | Measurements Performance Requirements | 29 |
| 4.6.1 | Measurements Performance for UE | 29 |
| 4.6.1.1 | Performance for UE Measurements in Downlink (RX) | 29 |
| 4.6.1.1.1 | P-CCPCH RSCP (1.28 Mcps TDD) | 29 |
| 4.6.1.1.2 | CPICH Measurements (FDD) | 29 |
| 4.6.1.1.3 | Timeslot ISCP | 29 |
| 4.6.1.1.4 | UTRA carrier RSSI | 29 |
| 4.6.1.1.5 | GSM carrier RSSI | 30 |
| 4.6.1.1.6 | SIR | 30 |
| 4.6.1.1.7 | Transport channel BLER | 30 |
| 4.6.1.1.8 | SFN-SFN observed time difference | 30 |
| 4.6.1.1.8.1 | Accuracy requirements | 30 |
| 4.6.1.1.8.2 | Range/mapping | 30 |
| 4.6.1.1.9 | Observed time difference to GSM cell | 31 |
| 4.6.1.1.10 | UE GPS Timing of Cell Frames for LCS | 32 |
| 4.6.1.1.11 | SFN-CFN observed time difference | 32 |
| 4.6.1.2 | Performance for UE Measurements in Uplink (TX) | 32 |
| 4.6.1.2.1 | UE transmitted power | 32 |
| 4.6.2 | Measurements Performance for UTRAN | 32 |
| 4.6.2.1 | Performance for UTRAN Measurements in Uplink (RX) | 32 |
| 4.6.2.1.1 | RSCP | 32 |
| 4.6.2.1.2 | Timeslot ISCP | 32 |
| 4.6.2.1.3 | RSSI | 32 |
| 4.6.2.1.4 | SIR | 32 |
| 4.6.2.1.5 | Transport Channel BER | 32 |
| 4.6.2.1.6 | RX Timing Deviation | 32 |
| 4.6.2.1.6.3 | Explanation difference | 33 |
| 4.6.2.1.7 | SYNC-UL Timing Deviation for 1.28 Mcps | 33 |
| 4.6.2.1.7.1 | Accuracy requirements | 33 |
| 4.6.2.1.7.2 | Range/mapping | 34 |
| 4.6.2.1.7.3 | Explanation difference | 34 |
| 4.6.2.2 | Performance for UTRAN Measurements in Downlink (TX) | 34 |
| 4.6.2.2.1 | Transmitted carrier power | 34 |
| 4.6.2.2.2 | Transmitted code power | 34 |
| 4.7 | FPACH physical layer information field definition (1.28 Mcps TDD) | 34 |
| 4.7.0 | Explanation difference | 35 |
| 4.7.1 | Received starting position of the UpPCH ($UpPCH_{POS}$) (1.28 Mcps TDD) | 35 |
| 4.7.1.1 | Range/mapping | 35 |
| 4.7.1.2 | Accuracy requirements | 35 |
| 4.7.2 | Transmit Power Level Command for the RACH message (1.28 Mcps TDD) | 36 |
| 4.7.2.1 | Range/mapping | 36 |
| 4.7.2.2 | Accuracy requirements | 36 |

| | | |
|---------------|-------------------------------------------------------|----|
| 5 | UE Radio Transmission and Reception | 37 |
| 5.1 | Frequency bands and channel arrangement | 37 |
| 5.1.1 | General | 37 |
| 5.1.2 | Frequency bands..... | 37 |
| 5.1.3 | TX–RX frequency separation | 37 |
| 5.1.3.1 | Description | 37 |
| 5.1.3.2 | Explanation of difference | 37 |
| 5.1.4 | Channel arrangement..... | 37 |
| 5.1.4.1 | Channel spacing | 37 |
| 5.1.4.1.1 | Background..... | 37 |
| 5.1.4.1.2 | Channel spacing | 37 |
| 5.1.4.2 | Channel raster..... | 37 |
| 5.1.4.3 | Channel number | 37 |
| 5.2 | Transmitter characteristics | 38 |
| 5.2.1 | General | 38 |
| 5.2.2 | Transmit power..... | 38 |
| 5.2.2.1 | User Equipment maximum output power..... | 38 |
| 5.2.3 | UE frequency stability | 38 |
| 5.2.4 | Output power dynamics | 38 |
| 5.2.4.1 | Open loop power control | 38 |
| 5.2.4.1.1 | Minimum requirement | 38 |
| 5.2.4.2 | Closed loop power control in the uplink | 38 |
| 5.2.4.2.1 | Power control steps..... | 38 |
| 5.2.4.2.1.1 | Minimum requirement | 38 |
| 5.2.4.3 | Minimum transmit output power | 39 |
| 5.2.4.3.1 | Minimum requirement | 39 |
| 5.2.4.3.2 | Rationale | 39 |
| 5.2.4.4 | Out-of-synchronisation handling of output power | 39 |
| 5.2.4.4.1 | Requirement..... | 39 |
| 5.2.4.4.2 | Rationale | 40 |
| 5.2.5 | Transmit ON/OFF power..... | 41 |
| 5.2.5.1 | Transmit OFF power | 41 |
| 5.2.5.1.1 | Minimum Requirement | 41 |
| 5.2.5.1.2 | Rational..... | 41 |
| 5.2.5.2 | Transmit ON/OFF Time mask..... | 42 |
| 5.2.5.2.1 | Minimum Requirement | 42 |
| 5.2.5.2.1 | Rationales | 42 |
| 5.2.5.2.1.1 | Timing advance..... | 43 |
| 5.2.5.2.2 | Switching time | 43 |
| 5.2.5.2.3 | Delay spread | 43 |
| 5.2.5.2.4 | BS Synchronization accuracy | 43 |
| 5.2.6 | Output RF spectrum emissions | 44 |
| 5.2.6.1 | Occupied bandwidth..... | 44 |
| 5.2.6.1.1 | Description | 44 |
| 5.2.6.1.2 | Explanation of difference | 44 |
| 5.2.6.2 | Out of band emission..... | 44 |
| 5.2.6.2.1 | Spectrum emission mask | 44 |
| 5.2.6.2.1.1 | Minimum Requirement | 44 |
| 5.2.6.2.1.2 | Rationale | 45 |
| 5.2.6.2.1.2.1 | Frequency offset..... | 45 |
| 5.2.6.2.1.2.2 | Measurement bandwidth..... | 46 |
| 5.2.6.2.1.2.3 | Mask shape..... | 46 |
| 5.2.6.2.2 | Adjacent Channel Leakage power Ratio (ACLR)..... | 46 |
| 5.2.6.3 | Spurious emissions | 46 |
| 5.2.6.3.1 | Minimum Requirement | 46 |
| 5.2.6.3.2 | Explanation of difference | 47 |
| 5.2.7 | Transmit intermodulation | 47 |
| 5.2.7.1 | Minimum requirements..... | 47 |
| 5.2.8 | Transmit Modulation | 48 |
| 5.2.8.1 | Transmit pulse shape filter | 48 |
| 5.2.8.2 | Error Vector Magnitude..... | 48 |
| 5.2.8.2.1 | Minimum Requirement | 48 |

| | | |
|-----------|--------------------------------------------------------------|----|
| 5.2.8.3 | Peak Code Domain Error | 48 |
| 5.2.8.3.1 | Minimum Requirement | 48 |
| 5.2.8.3.1 | Rationale | 48 |
| 5.3 | Receiver characteristics | 48 |
| 5.3.1 | General | 48 |
| 5.3.2 | Diversity characteristics | 48 |
| 5.3.3 | Reference sensitivity level | 49 |
| 5.3.3.1 | Minimum Requirements | 49 |
| 5.3.3.2 | Simulation results | 49 |
| 5.3.3.3 | Rationale | 50 |
| 5.3.4 | Maximum input level | 50 |
| 5.3.4.1 | Minimum Requirements | 50 |
| 5.3.5 | Adjacent Channel Selectivity (ACS) | 50 |
| 5.3.5.1 | Minimum Requirement | 50 |
| 5.3.5.2 | Rationale | 50 |
| 5.3.6 | Blocking characteristics | 51 |
| 5.3.6.1 | Minimum Requirement | 51 |
| 5.3.6.2 | Rationale | 52 |
| 5.3.6.2.1 | 3.2 MHz blocking requirement | 52 |
| 5.3.6.2.2 | ACS, Adjacent channel selectivity and NF, Noise figure | 52 |
| 5.3.6.2.3 | Out of band blocking requirement | 52 |
| 5.3.7 | Spurious response | 52 |
| 5.3.7.1 | Minimum Requirements | 52 |
| 5.3.7.2 | Rationale | 52 |
| 5.3.8 | Intermodulation characteristics | 53 |
| 5.3.8.1 | Minimum Requirements | 53 |
| 5.3.8.2 | Rationale | 53 |
| 5.3.9 | Spurious emissions | 53 |
| 5.3.9.1 | Minimum Requirement | 53 |
| 5.3.9.2 | Rationale | 53 |
| 5.4 | Performance requirement | 54 |
| 5.4.1 | General | 54 |
| 5.4.2 | Demodulation in static propagation conditions | 54 |
| 5.4.2.1 | Demodulation of DCH | 54 |
| 5.4.2.1.1 | Minimum requirement | 54 |
| 5.4.2.1.2 | Rationale | 55 |
| 5.4.3 | Demodulation of DCH in multipath fading conditions | 55 |
| 5.4.3.1 | Multipath fading Case 1 | 55 |
| 5.4.3.1.1 | Minimum requirement | 55 |
| 5.4.3.2 | Multipath fading Case 2 | 56 |
| 5.4.3.2.1 | Minimum requirement | 56 |
| 5.4.3.3 | Multipath fading Case 3 | 56 |
| 5.4.3.3.1 | Minimum requirement | 56 |
| 5.4.3.4 | Explanation difference | 57 |
| 6 | BS radio transmission and reception | 57 |
| 6.1 | Frequency bands and channel arrangement | 57 |
| 6.1.1 | General | 57 |
| 6.1.2 | Frequency bands | 57 |
| 6.1.3 | TX–RX frequency separation | 57 |
| 6.1.3.1 | Description | 57 |
| 6.1.3.2 | Explanation of difference | 58 |
| 6.1.4 | Channel arrangement | 58 |
| 6.1.4.1 | Channel spacing | 58 |
| 6.1.4.1.1 | Background | 58 |
| 6.1.4.1.2 | Channel spacing | 58 |
| 6.1.4.2 | Channel raster | 58 |
| 6.1.4.3 | Channel number | 58 |
| 6.2 | Transmitter characteristics | 58 |
| 6.2.1 | General | 58 |
| 6.2.2 | Base station output power | 58 |
| 6.2.2.1 | Base station maximum output power | 58 |

| | | |
|---------------|-----------------------------------------------------------------------------------------------------------|----|
| 6.2.2.1.1 | Minimum requirement | 58 |
| 6.2.3 | Frequency stability | 58 |
| 6.2.4 | Output power dynamics | 58 |
| 6.2.4.1 | Inner loop power control | 59 |
| 6.2.4.2 | Power control steps..... | 59 |
| 6.2.4.2.1 | Minimum requirement | 59 |
| 6.2.4.3 | Power control dynamic range | 59 |
| 6.2.4.3.1 | Minimum requirement | 59 |
| 6.2.4.4 | Minimum transmit power | 59 |
| 6.2.4.4.1 | Minimum requirement | 59 |
| 6.2.4.5 | Primary CCPCH power | 59 |
| 6.2.5 | Transmit ON/OFF power..... | 59 |
| 6.2.5.1 | Transmit OFF power | 59 |
| 6.2.5.1.1 | Minimum Requirement | 59 |
| 6.2.5.1.2 | Rationale..... | 59 |
| 6.2.5.2 | Transmit ON/OFF Time mask..... | 60 |
| 6.2.5.2.1 | Minimum Requirement..... | 60 |
| 6.2.6 | Output RF spectrum emissions | 60 |
| 6.2.6.1 | Occupied bandwidth..... | 60 |
| 6.2.6.1.1 | Description | 60 |
| 6.2.6.1.2 | Explanation of difference | 60 |
| 6.2.6.2 | Out of band emission..... | 60 |
| 6.2.6.2.1 | Spectrum emission mask | 60 |
| 6.2.6.2.2 | Explanation | 62 |
| 6.2.6.2A | Adjacent Channel Leakage power Ratio(ACLR) | 63 |
| 6.2.6.2A.1 | Minimum requirement | 63 |
| 6.2.6.2A.2 | Requirement in case of operation in proximity to TDD BS or FDD BS operating on an adjacent frequency..... | 63 |
| 6.2.6.2A.3 | Requirement in case of co-siting with TDD BS or FDD BS operating on an adjacent frequency..... | 64 |
| 6.2.6.3 | Spurious emissions | 64 |
| 6.2.6.3.1 | Mandatory Requirements | 64 |
| 6.2.6.3.1.1 | Spurious emissions (Category A) | 64 |
| 6.2.6.3.1.2 | Spurious emissions (Category B) | 65 |
| 6.2.6.3.1.2.1 | Minimum Requirement | 65 |
| 6.2.6.3.2 | Co-existence with GSM 900 | 65 |
| 6.2.6.3.2.1 | Operation in the same geographic area | 65 |
| 6.2.6.3.2.1.1 | Minimum requirement..... | 65 |
| 6.2.6.3.2.2 | Co-located base stations..... | 66 |
| 6.2.6.3.2.2.1 | Minimum requirement..... | 66 |
| 6.2.6.3.3 | Co-existence with DCS 1800..... | 66 |
| 6.2.6.3.3.1 | Operation in the same geographic area | 66 |
| 6.2.6.3.3.1.1 | Minimum requirement..... | 66 |
| 6.2.6.3.3.2 | Co-located base stations | 66 |
| 6.2.6.3.3.2.1 | Minimum requirement..... | 66 |
| 6.2.6.3.4 | Co-existence with UTRA FDD | 66 |
| 6.2.6.3.4.1 | Operation in the same geographic area | 66 |
| 6.2.6.3.4.1.1 | Minimum requirement..... | 66 |
| 6.2.6.3.4.2 | Co-located base stations | 66 |
| 6.2.6.3.4.2.1 | Minimum requirement..... | 66 |
| 6.2.7 | Transmit intermodulation | 66 |
| 6.2.7.0 | Explanation of difference | 67 |
| 6.2.7.1 | Minimum requirement | 67 |
| 6.2.8 | Transmit modulation..... | 67 |
| 6.2.8.1 | Transmit pulse shape filter | 67 |
| 6.2.8.1.1 | Explanation of difference | 67 |
| 6.2.8.2 | Modulation Accuracy..... | 67 |
| 6.2.8.2.1 | Minimum Requirement | 67 |
| 6.2.8.3 | Peak Code Domain Error..... | 67 |
| 6.2.8.3.1 | Minimum Requirement | 68 |
| 6.2.8.3.2 | Rationale..... | 68 |
| 6.3 | Receiver characteristics | 68 |

| | | |
|-----------|-------------------------------------------------------------------------------|----|
| 6.3.1 | General | 68 |
| 6.3.2 | Reference sensitivity level | 68 |
| 6.3.2.1 | Minimum Requirement | 68 |
| 6.3.2.2 | Rationale | 68 |
| 6.3.2.3 | Simulation results | 69 |
| 6.3.2.4 | Maximum Frequency Deviation for Receiver Performance | 69 |
| 6.3.3 | Dynamic range | 69 |
| 6.3.3.1 | Minimum requirement | 69 |
| 6.3.3.2 | Rationale | 70 |
| 6.3.4 | Adjacent Channel Selectivity (ACS) | 70 |
| 6.3.4.1 | Minimum Requirement | 70 |
| 6.3.4.2 | Rationale | 70 |
| 6.3.5 | Blocking characteristics | 71 |
| 6.3.5.1 | Minimum Requirements | 71 |
| 6.3.6 | Intermodulation characteristics | 71 |
| 6.3.6.1 | Rationale | 72 |
| 6.3.7 | Spurious emissions | 72 |
| 6.3.7.1 | Minimum Requirement | 72 |
| 6.3.7.2 | Rationale | 72 |
| 6.4 | Performance requirement | 73 |
| 6.4.1 | General | 73 |
| 6.4.2 | Demodulation in static propagation conditions | 73 |
| 6.4.2.1 | Demodulation of DCH | 73 |
| 6.4.2.1.1 | Minimum requirement | 73 |
| 6.4.3 | Demodulation of DCH in multipath fading conditions | 74 |
| 6.4.3.1 | Multipath fading Case 1 | 74 |
| 6.4.3.1.1 | Minimum requirement | 74 |
| 6.4.3.2 | Multipath fading Case 2 | 74 |
| 6.4.3.2.1 | Minimum requirement | 75 |
| 6.4.3.3 | Multipath fading Case 3 | 75 |
| 6.4.3.3.1 | Minimum requirement | 75 |
| 6.4.3.4 | Explanation difference | 76 |
| 7 | Base Station EMC | 76 |
| 7.1 | Test conditions | 76 |
| 7.1.1 | General | 76 |
| 7.1.2 | Arrangements for establishing a communication link | 76 |
| 7.1.3 | Narrow band responses on receivers | 76 |
| 7.2 | Performance assessment | 77 |
| 7.2.1 | General | 77 |
| 7.2.2 | Ancillary equipment | 77 |
| 7.3 | Performance Criteria | 77 |
| 7.3.1 | Performance criteria A for continuous phenomena for BS | 77 |
| 7.3.2 | Performance criteria B for transient phenomena for BS | 77 |
| 7.3.3 | Performance criteria C for BS | 77 |
| 7.3.4 | Performance criteria A for continuous phenomena for Ancillary equipment | 77 |
| 7.3.5 | Performance criteria B for transient phenomena for Ancillary equipment | 77 |
| 7.3.6 | Performance criteria C for Ancillary equipment | 77 |
| 7.4 | Applicability overview | 77 |
| 7.4.1 | Emission | 77 |
| 7.4.2 | Immunity | 77 |
| 8 | BS conformance testing | 78 |
| 8.1 | Frequency bands and channel arrangement | 78 |
| 8.1.1 | General | 78 |
| 8.1.2 | Frequency bands | 78 |
| 8.1.3 | TX–RX frequency separation | 78 |
| 8.1.3.1 | Description | 78 |
| 8.1.3.2 | Explanation of difference | 78 |
| 8.1.4 | Channel arrangement | 78 |
| 8.1.4.1 | Channel spacing | 78 |
| 8.1.4.1.1 | Background | 78 |

| | | |
|-------------|-----------------------------------------------------|----|
| 8.1.4.1.2 | Channel spacing | 78 |
| 8.1.4.2 | Channel raster | 78 |
| 8.1.4.3 | Channel number | 78 |
| 8.2 | General test conditions and declarations | 79 |
| 8.2.1 | Base station classes | 79 |
| 8.2.2 | Output power and determination of power class | 79 |
| 8.2.3 | Specified frequency range | 79 |
| 8.2.4 | Spectrum emission mask | 79 |
| 8.2.5 | Adjacent Channel Leakage power Ratio (ACLR) | 79 |
| 8.2.6 | Tx spurious emissions | 79 |
| 8.2.6.1 | Category of spurious emissions limit | 79 |
| 8.2.6.2 | Co-existence with GSM | 79 |
| 8.2.6.3 | Co-existence with DCS 1800 | 79 |
| 8.2.6.4 | Co-existence with UTRA FDD | 79 |
| 8.2.7 | Blocking characteristics | 79 |
| 8.2.8 | Test environments | 79 |
| 8.2.9 | Interpretation of measurement results | 79 |
| 8.2.10 | Selection of configurations for testing | 79 |
| 8.2.11 | BS Configurations | 80 |
| 8.2.12 | Overview of the conformance test requirements | 80 |
| 8.2.13 | Format and interpretation of tests | 80 |
| 8.3 | Transmitter characteristics | 80 |
| 8.3.1 | General | 80 |
| 8.3.2 | Maximum output power | 80 |
| 8.3.2.1 | Definition and applicability | 80 |
| 8.3.2.2 | Conformance requirements | 80 |
| 8.3.2.3 | Test purpose | 80 |
| 8.3.2.4 | Method of test | 80 |
| 8.3.2.4.1 | Initial conditions | 80 |
| 8.3.2.4.2 | Procedure | 81 |
| 8.3.2.5 | Test requirements | 81 |
| 8.3.2.6 | Explanation difference | 81 |
| 8.3.3 | Frequency stability | 81 |
| 8.3.3.1 | Definition and applicability | 81 |
| 8.3.3.2 | Conformance requirement | 81 |
| 8.3.3.3 | Test purpose | 81 |
| 8.3.3.4 | Method of test | 81 |
| 8.3.3.4.1 | Initial conditions | 81 |
| 8.3.3.4.2 | Procedure | 82 |
| 8.3.3.5 | Test requirement | 82 |
| 8.3.3.6 | Explanation difference | 82 |
| 8.3.4 | Output power dynamics | 82 |
| 8.3.4.1 | Inner loop power control | 82 |
| 8.3.4.2 | Power control steps | 82 |
| 8.3.4.2.1 | Definition and applicability | 82 |
| 8.3.4.2.2 | Conformance requirements | 82 |
| 8.3.4.2.3 | Test purpose | 82 |
| 8.3.4.2.4 | Method of test | 83 |
| 8.3.4.2.4.1 | Initial conditions | 83 |
| 8.3.4.2.4.2 | Procedure | 83 |
| 8.3.4.2.5 | Test requirements | 83 |
| 8.3.4.2.6 | Explanation difference | 83 |
| 8.3.4.3 | Power control dynamic range | 84 |
| 8.3.4.3.1 | Definition and applicability | 84 |
| 8.3.4.3.2 | Conformance requirements | 84 |
| 8.3.4.3.3 | Test purpose | 84 |
| 8.3.4.3.4 | Method of test | 84 |
| 8.3.4.3.4.1 | Initial conditions | 84 |
| 8.3.4.3.4.2 | Procedure | 84 |
| 8.3.4.3.5 | Test requirements | 85 |
| 8.3.4.3.6 | Explanation difference | 85 |
| 8.3.4.4 | Minimum transmit power | 85 |

| | | |
|---------------|--------------------------------------------------|----|
| 8.3.4.4.1 | Definition and applicability | 85 |
| 8.3.4.4.2 | Conformance requirements | 85 |
| 8.3.4.4.3 | Test purpose..... | 85 |
| 8.3.4.4.4 | Method of test..... | 85 |
| 8.3.4.4.4.1 | Initial conditions | 85 |
| 8.3.4.4.4.2 | Procedure | 86 |
| 8.3.4.4.5 | Test requirements | 86 |
| 8.3.4.4.6 | Explanation difference | 86 |
| 8.3.4.5 | Primary CCPCH power | 86 |
| 8.3.4.5.1 | Definition and applicability | 86 |
| 8.3.4.5.2 | Conformance requirement | 86 |
| 8.3.4.5.3 | Test purpose..... | 86 |
| 8.3.4.5.4 | Method of test..... | 86 |
| 8.3.4.5.4.1 | Initial conditions | 86 |
| 8.3.4.5.4.2 | Procedure | 87 |
| 8.3.4.5.5 | Test requirement | 87 |
| 8.3.4.5.6 | Explanation difference | 87 |
| 8.3.5 | Transmit ON/OFF power | 87 |
| 8.3.5.1 | Transmit OFF power | 87 |
| 8.3.5.1.1 | Definition and applicability | 87 |
| 8.3.5.1.2 | Conformance requirements | 87 |
| 8.3.5.1.3 | Test purpose..... | 87 |
| 8.3.5.1.4 | Method of test..... | 87 |
| 8.3.5.1.4.1 | Initial conditions | 87 |
| 8.3.5.1.4.2 | Procedure | 88 |
| 8.3.5.1.5 | Test requirements | 88 |
| 8.3.5.2 | Transmit ON/OFF time mask | 88 |
| 8.3.5.2.1 | Definition and applicability | 88 |
| 8.3.5.2.2 | Conformance requirements | 88 |
| 8.3.5.2.3 | Test purpose..... | 88 |
| 8.3.5.2.4 | Method of test..... | 88 |
| 8.3.5.2.4.1 | Initial conditions | 88 |
| 8.3.5.2.4.2 | Procedure | 89 |
| 8.3.5.2.5 | Test requirements | 89 |
| 8.3.5.2.6 | Explanation difference | 89 |
| 8.3.6 | Output RF spectrum emissions | 89 |
| 8.3.6.1 | Occupied bandwidth..... | 89 |
| 8.3.6.1.1 | Definition and applicability | 89 |
| 8.3.6.1.2 | Conformance requirements | 89 |
| 8.3.6.1.3 | Test purpose..... | 89 |
| 8.3.6.1.4 | Method of test..... | 89 |
| 8.3.6.1.4.1 | Initial conditions | 89 |
| 8.3.6.1.4.2 | Procedure | 90 |
| 8.3.6.1.5 | Test requirements | 90 |
| 8.3.6.1.6 | Explanation difference | 90 |
| 8.3.6.2 | Out of band emission..... | 90 |
| 8.3.6.2.1 | Spectrum emission mask | 90 |
| 8.3.6.2.1.1 | Definition and applicability | 90 |
| 8.3.6.2.1.2 | Conformance requirements | 90 |
| 8.3.6.2.1.3 | Test purpose | 91 |
| 8.3.6.2.1.4 | Method of test | 91 |
| 8.3.6.2.1.4.1 | Initial conditions | 91 |
| 8.3.6.2.1.4.2 | Procedure | 91 |
| 8.3.6.2.1.5 | Test requirements | 91 |
| 8.3.6.2.2 | Adjacent Channel Leakage power Ratio (ACLR)..... | 91 |
| 8.3.6.2.2.1 | Definition and applicability | 91 |
| 8.3.6.2.2.2 | Conformance requirements | 91 |
| 8.3.6.2.2.3 | Test purpose | 92 |
| 8.3.6.2.2.4 | Method of test | 92 |
| 8.3.6.2.2.4.1 | Initial conditions | 92 |
| 8.3.6.2.2.4.2 | Procedure | 92 |
| 8.3.6.2.2.5 | Test requirements | 92 |

| | | |
|-------------|------------------------------------------|----|
| 8.3.6.3 | Spurious emissions | 93 |
| 8.3.6.3.1 | Definition and applicability | 93 |
| 8.3.6.3.2 | Conformance requirements | 93 |
| 8.3.6.3.3 | Test purpose..... | 93 |
| 8.3.6.3.4 | Method of test..... | 93 |
| 8.3.6.3.4.1 | Initial conditions | 93 |
| 8.3.6.3.4.2 | Procedure | 93 |
| 8.3.6.3.5 | Test requirements | 94 |
| 8.3.6.3.6 | Explanation difference | 94 |
| 8.3.7 | Transmit intermodulation | 94 |
| 8.3.7.1 | Definition and applicability | 94 |
| 8.3.7.2 | Conformance requirements | 94 |
| 8.3.7.3 | Test purpose..... | 94 |
| 8.3.7.4 | Method of test..... | 94 |
| 8.3.7.4.1 | Initial conditions | 94 |
| 8.3.7.4.2 | Procedure..... | 95 |
| 8.3.7.5 | Test requirements..... | 95 |
| 8.3.7.6 | Explanation difference | 95 |
| 8.3.8 | Transmit Modulation | 95 |
| 8.3.8.1 | Modulation accuracy..... | 95 |
| 8.3.8.1.1 | Definition and applicability | 95 |
| 8.3.8.1.2 | Conformance requirements | 96 |
| 8.3.8.1.3 | Test purpose..... | 96 |
| 8.3.8.1.4 | Method of test..... | 96 |
| 8.3.8.1.4.1 | Initial conditions | 96 |
| 8.3.8.1.4.2 | Procedure | 96 |
| 8.3.8.1.5 | Test requirements | 96 |
| 8.3.8.1.6 | Explanation difference | 96 |
| 8.3.8.2 | Peak code domain error | 96 |
| 8.3.8.2.1 | Definition and applicability | 96 |
| 8.3.8.2.2 | Conformance requirements | 96 |
| 8.3.8.2.3 | Test purpose..... | 97 |
| 8.3.8.2.4 | Method of test..... | 97 |
| 8.3.8.2.4.1 | Initial conditions | 97 |
| 8.3.8.2.4.2 | Procedure | 97 |
| 8.3.8.2.5 | Test requirements..... | 97 |
| 8.3.8.2.6 | Explanation difference | 97 |
| 8.4 | Receiver characteristics | 97 |
| 8.4.1 | General..... | 97 |
| 8.4.2 | Reference sensitivity level | 97 |
| 8.4.2.1 | Definition and applicability | 97 |
| 8.4.2.2 | Conformance requirements | 97 |
| 8.4.2.3 | Test purpose..... | 98 |
| 8.4.2.4 | Method of test..... | 98 |
| 8.4.2.4.1 | Initial conditions | 98 |
| 8.4.2.4.2 | Procedure..... | 98 |
| 8.4.2.5 | Test requirements | 98 |
| 8.4.2.6 | Explanation difference | 98 |
| 8.4.3 | Dynamic range..... | 98 |
| 8.4.3.1 | Definition and applicability | 98 |
| 8.4.3.2 | Conformance requirements | 98 |
| 8.4.3.3 | Test purpose..... | 98 |
| 8.4.3.4 | Method of test..... | 98 |
| 8.4.3.4.1 | Initial conditions | 98 |
| 8.4.3.4.2 | Procedure..... | 98 |
| 8.4.3.5 | Test requirement | 99 |
| 8.4.3.6 | Explanation difference | 99 |
| 8.4.4 | Adjacent Channel Selectivity (ACS) | 99 |
| 8.4.4.1 | Definition and applicability..... | 99 |
| 8.4.4.2 | Conformance requirements | 99 |
| 8.4.4.3 | Test purpose..... | 99 |
| 8.4.4.4 | Method of test..... | 99 |

| | | |
|-------------|----------------------------------------------------------|-----|
| 8.4.4.4.1 | Initial conditions | 99 |
| 8.4.4.4.2 | Procedure..... | 99 |
| 8.4.4.5 | Test requirements..... | 99 |
| 8.4.4.6 | Explanation difference | 100 |
| 8.4.5 | Blocking characteristics | 100 |
| 8.4.5.1 | Definition and applicability..... | 100 |
| 8.4.5.2 | Conformance requirements | 100 |
| 8.4.5.3 | Test purpose..... | 100 |
| 8.4.5.4 | Method of test..... | 100 |
| 8.4.5.4.1 | Initial conditions | 100 |
| 8.4.5.4.2 | Procedure..... | 100 |
| 8.4.5.5 | Test requirements..... | 100 |
| 8.4.5.6 | Explanation difference | 101 |
| 8.4.6 | Intermodulation characteristics | 101 |
| 8.4.6.1 | Definition and applicability..... | 101 |
| 8.4.6.2 | Conformance requirements | 101 |
| 8.4.6.3 | Test purpose..... | 101 |
| 8.4.6.4 | Method of test..... | 101 |
| 8.4.6.4.1 | Initial conditions | 101 |
| 8.4.6.4.2 | Procedure..... | 101 |
| 8.4.6.5 | Test requirements..... | 102 |
| 8.4.6.6 | Explanation difference | 102 |
| 8.4.7 | Spurious emissions..... | 102 |
| 8.4.7.1 | Definition and applicability..... | 102 |
| 8.4.7.2 | Conformance requirements | 102 |
| 8.4.7.3 | Test requirements..... | 102 |
| 8.4.7.4 | Method of test..... | 102 |
| 8.4.7.4.1 | Initial conditions | 102 |
| 8.4.7.4.2 | Procedure..... | 103 |
| 8.4.7.5 | Test requirements..... | 103 |
| 8.4.7.6 | Explanation difference | 103 |
| 8.5 | Performance requirements | 103 |
| 8.5.1 | General..... | 103 |
| 8.5.2 | Demodulation in static propagation conditions..... | 103 |
| 8.5.2.1 | Demodulation of DCH | 103 |
| 8.5.2.1.1 | Definition and applicability..... | 103 |
| 8.5.2.1.2 | Conformance requirements | 103 |
| 8.5.2.1.3 | Test purpose..... | 104 |
| 8.5.2.1.4 | Method of test..... | 104 |
| 8.5.2.1.4.1 | Initial conditions | 104 |
| 8.5.2.1.4.2 | Procedure | 104 |
| 8.5.2.1.5 | Test requirements | 105 |
| 8.5.2.1.6 | Explanation difference | 105 |
| 8.5.3 | Demodulation of DCH in multipath fading conditions | 105 |
| 8.5.3.1 | Multipath fading Case 1 | 105 |
| 8.5.3.1.1 | Definition and applicability..... | 105 |
| 8.5.3.1.2 | Conformance requirements | 105 |
| 8.5.3.1.3 | Test purpose..... | 106 |
| 8.5.3.1.4 | Method of test..... | 106 |
| 8.5.3.1.4.1 | Initial conditions | 106 |
| 8.5.3.1.4.2 | Procedure | 106 |
| 8.5.3.1.5 | Test requirements | 107 |
| 8.5.3.1.6 | Explanation difference | 107 |
| 8.5.3.2 | Multipath fading Case 2..... | 107 |
| 8.5.3.2.1 | Definition and applicability | 107 |
| 8.5.3.2.2 | Conformance requirements | 107 |
| 8.5.3.2.3 | Test purpose..... | 108 |
| 8.5.3.2.4 | Method of test..... | 108 |
| 8.5.3.2.4.1 | Initial conditions | 108 |
| 8.5.3.2.4.2 | Procedure | 108 |
| 8.5.3.2.5 | Test requirements..... | 109 |
| 8.5.3.2.6 | Explanation difference | 109 |

| | | |
|-------------|------------------------------------------------------------------------|-----|
| 8.5.3.3 | Multipath fading Case 3..... | 109 |
| 8.5.3.3.1 | Definition and applicability..... | 109 |
| 8.5.3.3.2 | Conformance requirements..... | 109 |
| 8.5.3.3.3 | Test purpose..... | 110 |
| 8.5.3.3.4 | Method of test..... | 110 |
| 8.5.3.3.4.1 | Initial conditions..... | 110 |
| 8.5.3.3.4.2 | Procedure..... | 110 |
| 8.5.3.3.5 | Test requirements..... | 111 |
| 8.5.3.3.6 | Explanation difference..... | 111 |
| 9 | RF System scenarios..... | 112 |
| 9.1 | General..... | 112 |
| 9.2 | Methodology for coexistence studies 1.28 Mcps TDD/FDD..... | 112 |
| 9.2.1 | Overview of the simulation..... | 112 |
| 9.2.2 | Simulation parameters..... | 113 |
| 9.2.3 | Scenarios..... | 114 |
| 9.3 | Methodology for coexistence studies 1.28 Mcps TDD/ 3.84 Mcps TDD..... | 114 |
| 9.3.1 | Overview of Simulation..... | 114 |
| 9.3.2 | Simulation parameters..... | 115 |
| 9.3.3 | Scenarios..... | 116 |
| 9.4 | Methodology for coexistence studies 1.28 Mcps TDD/ 1.28 Mcps TDD..... | 117 |
| 9.4.1 | Overview of Simulation..... | 117 |
| 9.4.2 | Simulation parameters..... | 117 |
| 9.4.3 | Scenarios..... | 117 |
| 9.5 | Results, implementation issues and recommendations..... | 117 |
| 9.5.1 | 1.28 Mcps TDD /FDD..... | 117 |
| 9.5.1.1 | Simulation results..... | 117 |
| 9.5.1.2 | Conclusion..... | 118 |
| 9.5.2 | 1.28 Mcps TDD / 3.84 Mcps TDD..... | 118 |
| 9.5.2.1 | Simulation results..... | 118 |
| 9.5.2.2 | Conclusion..... | 118 |
| 9.5.3 | 1.28 Mcps TDD / 1.28 Mcps TDD..... | 118 |
| 9.5.3.1 | Simulation results..... | 118 |
| 9.5.3.2 | Conclusion..... | 119 |
| 9.6 | Information and General purpose materials..... | 119 |
| 9.6.1 | CDMA Definitions and Equations..... | 119 |
| 9.6.1.1 | CDMA-related definitions..... | 119 |
| 9.6.1.1.1 | Explanation difference..... | 119 |
| 9.6.1.2 | CDMA equations..... | 119 |
| 9.6.1.2.1 | BS Transmission Power..... | 119 |
| 9.7 | Link Level performances..... | 120 |
| 9.7.1 | Simulation results for 1.28 Mcps TDD performace..... | 120 |
| 9.7.1.1 | Simulation assumptions..... | 120 |
| 9.7.1.1.1 | Simulation chain..... | 120 |
| 9.7.1.1.1.1 | Downlink..... | 120 |
| 9.7.1.1.1.2 | Uplink..... | 121 |
| 9.7.1.1.2 | Simulation Assumptions..... | 122 |
| 9.7.1.1.2.1 | General..... | 122 |
| 9.7.1.1.2.2 | Additional downlink parameters..... | 122 |
| 9.7.1.1.2.3 | Additional uplink parameters..... | 123 |
| 9.7.1.2 | Simulation results..... | 123 |
| 9.7.1.2.1 | 12.2kps service..... | 123 |
| 9.7.1.2.1.1 | Graphical Presentation of 12.2 kbps service UL Simulation Results..... | 123 |
| 9.7.1.2.1.2 | Graphical Presentation of 12.2 kbps service DL Simulation Results..... | 125 |
| 9.7.1.2.2 | 64kps Service..... | 127 |
| 9.7.1.2.2.1 | Graphical Presentation of 64 kbps service UL Simulation Results..... | 127 |
| 9.7.1.2.2.2 | Graphical Presentation of 64 kbps service DL Simulation Results..... | 128 |
| 9.7.1.2.3 | 144kps Service..... | 130 |
| 9.7.1.2.3.1 | Graphical Presentation of 144 kbps service UL Simulation Results..... | 130 |
| 9.7.1.2.3.2 | Graphical Presentation of 144 kbps service DL Simulation Results..... | 132 |
| 9.7.1.2.4 | 384kps Service..... | 134 |
| 9.7.1.2.4.1 | Graphical Presentation of 384 kbps service UL Simulation Results..... | 134 |

| | | |
|-------------------------------|-----------------------------------------------------------------------------|------------|
| 9.7.1.2.4.2 | Graphical Presentation of 384 kbps service DL Simulation Results | 135 |
| 9.7.2 | 1.28 Mcps TDD and FDD link level simulation | 137 |
| Annex A (informative): | The key physical layer parameters for low chip rate TDD option | 138 |
| Annex B (informative): | Test Cases | 140 |
| B.a | Purpose of Annex | 140 |
| B.b | Requirement classification for statistical testing | 140 |
| B.b.1 | Types of requirements in TS 25.123 | 140 |
| B.1 | Idle Mode | 140 |
| B.1.1 | Cell selection | 140 |
| B.1.2 | Cell Re-Selection | 140 |
| B.1.2.1 | Single carrier case NTDD/NTDD cell re-selection | 140 |
| B.1.2.1.1 | Test Purpose and Environment | 140 |
| B.1.2.1.2 | Test Requirements | 144 |
| B.1.2.2 | NTDD/NTDD cell re-selection multi carrier case | 144 |
| B.1.2.2.1 | Test Purpose and Environment | 144 |
| B.1.2.2.2 | Test Requirements | 147 |
| B.1.2.3 | High chip rate TDD cell re-selection | 147 |
| B.1.2.3.1 | Test Purpose and Environment | 147 |
| B.1.2.3.2 | Test Requirements | 148 |
| B.1.2.4 | FDD cell re-selection | 148 |
| B.1.2.4.1 | Test Purpose and Environment | 148 |
| B.1.2.4.2 | Test Requirements | 149 |
| B.1.3 | Inter-RAT(GSM) cell re-selection | 150 |
| B.1.3.1 | Scenario | 150 |
| B.1.3.1.1 | Test Purpose and Environment | 150 |
| B.1.3.1.2 | Test Requirements | 151 |
| B.2 | UTRAN Connected Mode Mobility | 152 |
| B.2.1 | 1.28 Mcps TDD/TDD Handover | 152 |
| B.2.2 | 1.28 Mcps TDD/FDD Handover | 152 |
| B.2.3 | 1.28 Mcps TDD/GSM Handover | 152 |
| B.2.4 | Cell Re-selection in CELL_FACH | 152 |
| B.2.4.1 | One frequency present in neighbour list | 152 |
| B.2.4.1.1 | Test Purpose and Environment | 152 |
| B.2.4.1.2 | Test Requirements | 155 |
| B.2.4.2 | Two frequencies present in the neighbour list | 155 |
| B.2.4.2.1 | Test Purpose and Environment | 155 |
| B.2.4.2.2 | Test Requirements | 158 |
| B.2.5 | Cell Re-selection in CELL_PCH | 158 |
| B.2.6 | Cell Re-selection in URA_PCH | 158 |
| B.3 | Dynamic Channel Allocation | 158 |
| B.4 | Timing characteristics | 158 |
| B.5 | UE Measurements Procedures | 158 |
| B.5.1 | 1.28 Mcps TDD measurements | 158 |
| B.5.1.1 | Event triggered reporting in AWGN propagation conditions | 158 |
| B.5.1.1.1 | Test Purpose and Environment | 158 |
| B.5.1.1.1.1 | Explanation difference | 159 |
| B.5.1.1.2 | Test Requirements | 159 |
| B.5.2 | FDD measurements | 160 |
| B.5.2.1 | Correct reporting of neighbours in AWGN propagation condition | 160 |
| B.5.2.1.1 | Test Purpose and Environment | 160 |
| B.5.2.1.1.1 | Explanation difference | 160 |
| B.5.2.1.2 | Test Requirements | 160 |
| B.6 | Measurement Performance Requirements | 161 |
| B.6.1 | Measurement Performance for UE | 161 |
| B.6.1.1 | TDD intra frequency measurements | 161 |

| | | |
|-----------------------------------------------------------------|----------------------------------------------------------------------------------------|------------|
| B.6.1.1.1 | Explanation difference | 161 |
| B.6.1.2 | TDD inter frequency measurements | 161 |
| B.6.1.2.1 | Explanation difference | 162 |
| B.6.1.3 | UTRA carrier RSSI inter frequency measurements | 162 |
| B.6.2 | Measurement Performance for UTRAN | 162 |
| Annex C (informative): Measurement Channels | | 164 |
| C.1 | General | 164 |
| C.2 | Reference Measurement Channels (Downlink) | 164 |
| C.2.0 | UL reference measurement channel (12.2 kbps, for definition of UE Tx parameters) | 164 |
| C.2.0.1 | Rationale | 165 |
| C.2.1 | DL reference measurement channel (12.2 kbps) | 166 |
| C.2.2 | DL reference measurement channel (64 kbps) | 167 |
| C.2.3 | DL reference measurement channel (144 kbps) | 168 |
| C.2.4 | DL reference measurement channel (384 kbps) | 169 |
| C.2.4.1 | Explanation difference | 170 |
| C.2.5 | BCH reference measurement channel | 170 |
| C.2.5.1 | Rationale | 171 |
| C.2.6 | UL multi code reference measurement channel (12.2 kbps) | 172 |
| C.2.6.1 | Rationale | 173 |
| C.3 | Reference measurement channels (Uplink) | 174 |
| C.3.1 | UL reference measurement channel (12.2 kbps) | 174 |
| C.3.2 | UL reference measurement channel (64 kbps) | 175 |
| C.3.3 | UL reference measurement channel (144 kbps) | 176 |
| C.3.4 | UL reference measurement channel (384 kbps) | 177 |
| C.3.5 | RACH reference measurement channel | 178 |
| C.3.5.1 | RACH mapped to 1 code SF16 | 178 |
| C.3.5.2 | RACH mapped to 1 code SF8 | 179 |
| C.3.5.3 | RACH mapped to 1 code SF4 | 179 |
| C.3.5.3.1 | Explanation difference | 180 |
| Annex D (informative): Propagation conditions | | 181 |
| D.1 | Static Propagation conditions | 181 |
| D.2 | Multi-path fading propagation conditions | 181 |
| D.2.1 | Rationale | 181 |
| Annex E (informative): Environmental conditions | | 182 |
| E.1 | General | 182 |
| E.2 | Environmental requirements for the UE | 182 |
| E.2.1 | Temperature | 182 |
| E.2.2 | Voltage | 182 |
| E.2.3 | Vibration | 182 |
| E.2.4 | Rationale | 183 |
| Annex F (informative): Terminal capabilities (TDD) | | 184 |
| Annex G (informative): Methods of measurement | | 185 |
| G.1 | Emission | 185 |
| G.1.1 | Methods of measurement and limits for EMC emissions | 185 |
| G.1.2 | Test configurations | 185 |
| G.1.3 | Radiated spurious emission from Base station and ancillary equipment | 185 |
| G.1.3.1 | Radiated spurious emission, Base stations | 185 |
| G.1.3.1.1 | Definition | 185 |
| G.1.3.1.2 | Test method | 185 |
| G.1.3.1.2.1 | Explanation difference | 185 |
| G.1.3.1.3 | Limits | 185 |
| G.1.3.2 | Radiated spurious emission, Ancillary equipment | 186 |

G.1.4 Conducted emission DC power input/output port.....186

G.1.5 Conducted emissions, AC mains power input/output port.....186

G.1.6 Harmonic Current emissions (AC mains input port).....186

G.1.7 Voltage fluctuations and flicker (AC mains input port)186

G.2 Immunity..... 186

Annex H (informative): Global in-channel Tx test.....187

H.1 General..... 187

H.2 Definition of the process..... 187

H.2.1 Basic principle187

H.2.2 Output signal of the Tx under test187

H.2.3 Reference signal.....187

H.2.4 Classification of measurement results.....187

H.2.5 Process definition to achieve results of type “deviation”187

H.2.6 Process definition to achieve results of type “residual”187

H.2.7 Error Vector Magnitude (EVM)187

H.2.8 Peak Code Domain Error (PCDE).....187

H.3 Applications 187

H.4 Notes..... 188

H.5 Rationale 188

Annex I (informative): Change History.....189

Foreword

This Technical Report has been produced by the 3GPP.

The contents of the present document are subject to continuing work within the TSG and may change following formal TSG approval. Should the TSG modify the contents of this TS, it will be re-released by the TSG with an identifying change of release date and an increase in version number as follows:

Version 3.y.z

where:

- x the first digit:
 - 1 presented to TSG for information;
 - 2 presented to TSG for approval;
 - 3 Indicates TSG approved document under change control.
- y the second digit is incremented for all changes of substance, i.e. technical enhancements, corrections, updates, etc.
- z the third digit is incremented when editorial only changes have been incorporated in the specification.

1 Scope

This technical Report identifies the RF Radio Transmission/Reception and Radio Resource Management requirements for the 1.28 Mcps UTRA TDD option, including the commonalities and differences. Furthermore, the impact on the RF system Scenarios and BS conformance testing is also identified.

2 References

The following documents contain provisions which, through reference in this text, constitute provisions of the present document.

- References are either specific (identified by date of publication, edition number, version number, etc.) or non-specific.
- For a specific reference, subsequent revisions do not apply.
- For a non-specific reference, the latest version applies. In the case of a reference to a 3GPP document (including a GSM document), a non-specific reference implicitly refers to the latest version of that document *in the same Release as the present document*.

- [1] 3GPP TS 25.102: "UE Radio transmission and reception (TDD)".
- [3] 3GPP TS 25.105: "BS Radio transmission and reception (TDD)".
- [4] 3GPP TS 25.123: "RF parameters in support of RRM (TDD)".
- [5] 3GPP TS 25.142: "Base Station conformance testing (TDD)".
- [6] 3GPP TS 25.113: "Base Station EMC".
- [7] 3GPP TR 25.942: "RF System scenarios".
- [8] 3GPP TS 25.922: "Radio Resource Management Strategies".
- [9] 3GPP TS 25.331: "Radio Resource Control (RRC) Protocol Specification".
- [10] 3GPP TR 25.928: "1.28 Mcps UTRA TDD Physical Layer".
- [11] 3GPP TS 25.214: "Physical layer procedures (FDD)".
- [12] 3GPP TS 45.010: "Radio subsystem synchronization".
- [13] 3GPP TS 25.225: "Physical layer; Measurements (TDD)".
- [14] 3GPP TS 25.215: "Physical layer; Measurements (FDD)".
- [15] 3GPP TS 25.306: "UE Radio Access capabilities".
- [16] ITU-R recommendation SM.329: "Unwanted emissions in the spurious domain".
- [17] 3GPP RAN WG4 meeting #6, tdoc R4-990393: "FDD UE Blocking Requirement".
- [18] 3GPP RAN WG4 meeting#7, tdoc R4-990457: "Blocking characteristics, Spurious response, Intermodulation characteristics for UE TDD".
- [19] 3GPP RAN WG4 meeting#6, tdoc R4-990431: "Revised FDD UE Blocking Requirement".

3 Abbreviations

(void)

4 RF Parameters in Support of Radio Resource Management

4.1 Idle Mode

4.1.1 Cell Selection

4.1.1.1 Introduction

After a UE has switched on and a PLMN has been selected, the cell selection process takes place. This process allows the UE to select a suitable cell where to camp on in order to access available services. In this process the UE can use stored information (stored information cell selection) or not (initial cell selection).

4.1.2 Cell Re-Selection

4.1.2.1 Introduction

The cell re-selection procedure allows the UE to select a more suitable cell and camp on it.

When the UE is in Normally Camped state it shall attempt to detect, synchronise and monitor cells indicated in the measurement control system information of the serving cell. If the occasions/triggers occur, as specified in 25.304, the UE shall perform the Cell Re-selection Evaluation process.

4.1.2.2 Requirements

4.1.2.2.1 Measurement and evaluation of cell selection criteria S of serving cell

The UE shall measure the PCCPCH RSCP level of the serving cell and evaluate the cell selection criterion S defined in TS 25.304 [8] for the serving cell once per DRX cycle. The UE shall filter the PCCPCH RSCP level of the serving cell using at least 2 measurements, which are taken so that the time difference between the measurements is at least $T_{\text{measureNTDD}}/2$ (see table 4.1).

If the UE has evaluated in N_{serv} successive measurements that the serving cell does not fulfill the cell selection criterion S the UE shall initiate the measurements of all neighbour cells indicated in the measurement control system information, regardless of the measurement rules currently limiting UE measurement activities.

If the UE has not found any new suitable cell based on searches and measurements of the neighbour cells indicated in the measurement control system information for [TBD] s, the UE shall initiate cell selection procedures for the selected PLMN as defined in TS 25.304 [8].

4.1.2.2.2 Measurement of intra-frequency cells

The UE shall measure PCCPCH RSCP at least every $T_{\text{measureNTDD}}$ (see table 4.1) for intra-frequency cells that are detected and measured according to the measurement rules. $T_{\text{measureNTDD}}$ is defined in Table 4.1. The UE shall filter PCCPCH RSCP measurements of each measured intra-frequency cell using at least 2 measurements, which are taken so that the time difference between the measurements is at least $T_{\text{measureNTDD}}/2$.

The filtering shall be such that the UE shall be capable of evaluating that an intra-frequency cell has become better than the serving cell within $T_{\text{evaluateNTDD}}$ (see table 4.1), from the moment the intra-frequency cell became at least [2]dB better ranked than the current serving cell, provided that $T_{\text{reselection}}$ timer is set to zero and PCCPCH RSCP is used as measurement quantity for cell reselection.

If parameter $T_{\text{reselection}}$ has value different from zero, the UE shall evaluate an intra-frequency cell better than the serving cell during the $T_{\text{reselection}}$ time, before the UE shall reselect the new cell.

4.1.2.2.3 Measurement of 1.28 Mcps TDD inter-frequency cells

The UE shall measure PCCPCH RSCP at least every $(N_{\text{carrier}}-1) * T_{\text{measureNTDD}}$ (see table 4.1) for inter-frequency cells that are detected and measured according to the measurement rules. The parameter N_{carrier} is the number of carriers used for NTDD cells. The maximum number of carriers is [3] including the carrier the UE is camped on. The UE shall filter PCCPCH RSCP measurements of each measured inter-frequency cell using at least 2 measurements, which are taken so that the time difference between the measurements is at least $T_{\text{measureNTDD}}/2$.

The filtering of PCCPCH RSCP shall be such that the UE shall be capable of evaluating that an already detected inter-frequency cell has become better ranked than the serving cell within $(N_{\text{carrier}}-1) * T_{\text{evaluateNTDD}}$ from the moment the inter-frequency cell became at least [3]dB better than the current serving cell provided that $T_{\text{reselection}}$ timer is set to zero. For non-detected inter-frequency cells, the filtering shall be such that the UE shall be capable of evaluating that inter-frequency cell has become better ranked than the serving cell within 30s from the moment the inter-frequency cell became at least [3]dB better than the current serving cell provided that $T_{\text{reselection}}$ timer is set to zero.

If $T_{\text{reselection}}$ timer has a value different from zero, the UE shall evaluate an inter-frequency cell better than the serving cell during the $T_{\text{reselection}}$ time, before the UE shall reselect the new cell.

4.1.2.3 High Chip Rate TDD re-selection

This requirement only applies to UEs supporting this mode.

The ranking of the low and high chip rate TDD cells shall be made according to the cell reselection criteria specified in TS 25.304 [8]. The use of mapping functions is indicated in the broadcast.

The UE shall measure PCCPCH RSCP at least every $N_{\text{TDDcarrier}} * T_{\text{measureTDD}}$ (see table 4.1) for inter-frequency cells that are detected and measured according to the measurement rules. The parameter N_{carrier} is the number of carriers used for 3.84 Mcps TDD cells. The maximum number of carriers is 3. The UE shall filter PCCPCH RSCP measurements of each measured high chip rate TDD cell using at least 2 measurements, which are taken so that the time difference between the measurements is at least $T_{\text{measureTDD}}/2$.

The filtering of PCCPCH RSCP shall be such that the UE shall be capable of evaluating that a high chip rate TDD cell has become better ranked than the serving cell within $N_{\text{TDDcarrier}} * T_{\text{evaluateTDD}}$ from the moment the inter-frequency cell became at least [3] better ranked than the current serving cell provided that $T_{\text{reselection}}$ timer is set to zero. For non-detected inter-frequency cells, the filtering shall be such that the UE shall be capable of evaluating that inter-frequency cell has become better ranked than the serving cell within 30s from the moment the inter-frequency cell became at least [3]dB better than the current serving cell provided that $T_{\text{reselection}}$ timer is set to zero.

4.1.2.4 FDD Cell re-selection

This requirement only applies to UEs supporting this mode.

The UE shall measure the signal level CPICH RSCP of each FDD neighbour cell indicated in the measurement control system information of the serving cell, according to the measurement rules defined in TS 25.304 [8], at least every $T_{\text{measureFDD}}$ (see table 4.1). The UE shall filter CPICH RSCP measurements of each measured inter-frequency cell using at least 2 measurements. The measurement samples for each cell shall be as far as possible uniformly distributed over the averaging period.

CPICH RSCP is used as measurement quantity for cell reselection, the filtering shall be such that the UE shall be capable of evaluating that an already detected inter-frequency cell has become better ranked than the serving cell within $N_{\text{FDDcarrier}} * T_{\text{evaluateFDD}}$ from the moment the inter-frequency cell became at least [5]dB better than the current serving cell provided that $T_{\text{reselection}}$ timer is set to zero. For non-detected inter-frequency cells, the filtering shall be such that the UE shall be capable of evaluating that inter-frequency cell has become better ranked than the serving cell within 30s from the moment the inter-frequency cell became at least [5]dB better than the current serving cell provided that $T_{\text{reselection}}$ timer is set to zero.

The ranking of the cells shall be made according to the cell reselection criteria specified in TS 25.304. The use of mapping functions is indicated in the broadcast.

4.1.3 Measurement of inter-RAT GSM cells

These requirements only apply to UEs supporting GSM.

The UE shall measure the signal level of each GSM neighbour cell indicated in the measurement control system information of the serving cell, according to the measurement rules defined in TS 25.304 [8], at least every $T_{\text{measureGSM}}$ (see table 4.1). The UE shall maintain a running average of 4 measurements for each cell. The measurement samples for each cell shall be as far as possible uniformly distributed over the averaging period.

The UE shall attempt to verify the BSIC for each of the 4 best ranked GSM BCCH carriers (the best ranked according to the cell reselection criteria defined in TS 25.304 [8]) at least every 30 seconds if GSM cells are measured according to the measurement rules. If a change of BSIC is detected for one GSM cell then that GSM BCCH carrier shall be treated as a new GSM neighbour cell.

If the UE detects a BSIC, which is not indicated in the measurement control system information, the UE shall not consider that GSM BCCH carrier in cell reselection. The UE also shall not consider the GSM BCCH carrier in cell reselection, if the UE can not demodulate the BSIC of that GSM BCCH carrier.

4.1.4 Evaluation of cell reselection criteria

The UE shall evaluate the cell re-selection criteria defined in TS 25.304 [8] for the cells, which have new measurement results available, at least every DRX cycle.

Cell reselection shall take place immediately after the UE has found a better suitable cell unless the UE has made cell reselection within the last 1 second.

4.1.5 Maximum interruption time in paging reception

UE shall perform the cell re-selection with minimum interruption in monitoring downlink channels for paging reception.

At intra-frequency cell re-selection, the UE shall monitor the downlink of current serving cell for paging reception until the UE is capable to start monitoring downlink channels of the target intra-frequency cell for paging reception. The interruption time shall not exceed [50]ms.

At inter-frequency and inter-RAT cell re-selection, the UE shall monitor the downlink of current serving cell for paging reception until the UE is capable to start monitoring downlink channels for paging reception of the target inter-frequency cell. The interruption time must not exceed $T_{\text{REP}} + [50]$ ms. T_{REP} is the longest repetition period for the system information required to be read by the UE to camp on the cell.

These requirements assume sufficient radio conditions, so that decoding of system information can be made without errors.

Table 4.1: $T_{\text{measureNTDD}}$, $T_{\text{evaluateNTDD}}$, $T_{\text{measureTDD}}$, $T_{\text{evaluateTDD}}$, $T_{\text{measureFDD}}$, $T_{\text{evaluateFDD}}$ and $T_{\text{measureGSM}}$

| DRX cycle length [s] | N_{serv} [number of successive measurements] | $T_{\text{measureNTDD}}$ [s] (number of DRX cycles) | $T_{\text{evaluateNTDD}}$ [s] (number of DRX cycles) | $T_{\text{measureTDD}}$ [s] (number of DRX cycles) | $T_{\text{evaluateTDD}}$ [s] (number of DRX cycles) |
|----------------------|-------------------------------------------------------|-----------------------------------------------------|------------------------------------------------------|----------------------------------------------------|-----------------------------------------------------|
| 0.08 | 4 | 0.64 (8 DRX cycles) | 2.56 (32 DRX cycles) | 0.64 (8 DRX cycles) | 2.56 (32 DRX cycles) |
| 0.16 | 4 | 0.64 (4) | 2.56 (16) | 0.64 (4) | 2.56 (16) |
| 0.32 | 4 | 1.28 (4) | 5.12 (16) | 1.28 (4) | 5.12 (16) |
| 0.64 | 4 | 1.28 (2) | 5.12 (8) | 1.28 (2) | 5.12 (8) |
| 1.28 | 2 | 1.28 (1) | 6.4 (5) | 1.28 (1) | 6.4 (5) |
| 2.56 | 2 | 2.56 (1) | 7.68 (3) | 2.56 (1) | 7.68 (3) |
| 5.12 | 1 | 5.12 (1) | 10.24 (2) | 5.12 (1) | 10.24 (2) |

Table 4.1 (prolongation)

| DRX cycle length [s] | N _{serv} [number of successive measurements] | T _{measureFDD} [s] (number of DRX cycles) | T _{evaluateFDD} [s] (number of DRX cycles) | T _{measureGSM} [s] (number of DRX cycles) |
|----------------------|-------------------------------------------------------|----------------------------------------------------|-----------------------------------------------------|----------------------------------------------------|
| 0.08 | 4 | 0.64 (8DRX cycles) | 2.56 (32 DRX cycles) | 2.56 (32 DRX cycles) |
| 0.16 | 4 | 0.64 (4) | 2.56 (16) | 2.56 (16) |
| 0.32 | 4 | 1.28 (4) | 5.12 (16) | 5.12 (16) |
| 0.64 | 4 | 1.28 (2) | 5.12 (8) | 5.12 (8) |
| 1.28 | 2 | 1.28 (1) | 6.4 (5) | 6.4 (5) |
| 2.56 | 2 | 2.56 (1) | 7.68 (3) | 7.68 (3) |
| 5.12 | 1 | 5.12 (1) | 10.24 (2) | 10.24 (2) |

In idle mode, UE shall support DRX cycles lengths 0.64, 1.28, 2.56 and 5.12 s.

4.1.6 Numbers of cells in neighbouring cell list

The UE shall be capable of monitoring [32] intra-frequency NTDD cells (including serving cell),

- [32] inter-frequency cells including low and high chip rate TDD Mode cells and FDD Mode cells if FDD and/or high chip rate TDD is supported by the UE
- the NTDD inter-frequency cells can be located on [x] additional frequencies besides the serving cell.
- the inter-frequency cells can be located on up to [x] carriers.

In addition the UE shall be able to monitor 32 GSM carriers if GSM is supported by the UE. UE measurement activity is controlled by measurement rules defined in in TS 25.304 [8], allowing the UE to limit its measurement activity if certain conditions are fulfilled.

4.2 Connected Mode

4.2.1 TDD/TDD Handover

The requirements apply for 1.28 Mcps and 3.84 Mcps handover.

4.2.1.1 Introduction

The purpose of TDD/TDD handover is to change the cell of the connection between UE and UTRAN. The handover procedure is initiated from UTRAN with a RRC message that implies a handover. The handover procedure may cause the UE to change its frequency.

The handover process should be implemented in both the UE and UTRAN. The UE measurements and which radio links the UE shall use is controlled by UTRAN with RRC signaling. For the handover preparation the UE receives from the UTRAN a list of cells (e.g. 1.28 Mcps TDD, or GSM). Which the UE shall monitor (see 'monitored set' in 3GPP TS 25.331 [9]) in its idle timeslots.

At the beginning of the measurement process the UE shall find synchronization to the cell to measure using the synchronization channel (DwPCH). This is described under 'cell search' in 3GPP TR 25.928 [10] ' if the monitored cell is a 1.28 Mcps TDD cell. For a TDD cell to monitor after this procedure the exact timing of the midamble of the P-CCPCH is known and the measurements can be performed. Depending on the UE implementation and if timing information about the cell to monitor is available, the UE may perform the measurements on the P-CCPCH directly without prior DwPCH synchronization.

4.2.1.2 Requirements

Requirements for 3.84 Mcps are only applicable if high chip rate TDD is supported by the UE.

4.2.1.2.1 Handover delay

Procedure delay for all procedures, that can command a hard handover, are specified in TS 25.331 [9].

When the UE receives a RRC message that implies a handover, with the activation time "now" or earlier than D_{handover} seconds from the end of the last TTI containing the RRC command, the UE shall start transmission within D_{handover} seconds from the end of the last TTI containing the RRC command.

If the access is delayed to an indicated activation time later than D_{handover} seconds from the end of the last TTI containing the RRC command, the UE shall be ready to start the transmission of the new uplink DPCH at the designated activation time.

where:

D_{handover} equals the RRC procedure delay defined in TS 25.331 [9] Section 13.5.2 plus the interruption time stated in section 4.2.1.2.2.

4.2.1.2.2 Interruption time

The interruption time i.e. the time between the last TTI containing a transport block on the old DPCH and the time the UE starts transmission of the new uplink DPCH, shall be less than the value in table 4.2. There is different requirement on the interruption time depending on if the cell is known or not.

A cell shall be regarded as known by the UE if it has been measured during the last 5 seconds or a dedicated connection existed between the UE and the cell during the last 5 seconds.

Table 4.2: TDD/ FDD handover – interruption time

| cell in the handover command message | Maximum delay [ms] | |
|--------------------------------------|--------------------|-------|
| | Known Cell | Cell |
| 1 | [40] | [350] |

The interruption time includes the time that can elapse till the appearance of the channel required for the synchronisation. And the time that can elapse till the appearance of the DwPTS in which the new uplink SYNC1 shall be transmitted, or in case of high chip rate TDD the new uplink DPCH, shall be transmitted, which can be up to one frame (10ms).

The requirement in Table 4.2 for the unknown cell shall apply if the signal quality of the unknown cell is good enough for successful synchronisation with one attempt.

NOTE: One synchronisation attempt can consist of coherent averaging using several frames.

4.2.2 1.28 Mcps TDD/FDD Handover

4.2.2.1 Introduction

The purpose of 1.28 Mcps TDD/FDD handover is to change the mode between 1.28 Mcps TDD and FDD.

The handover procedure is initiated from UTRAN with a handover command message. The handover procedure causes the UE to change its frequency.

4.2.2.2 Requirements

These requirements shall apply only to 1.28 Mcps TDD/FDD UE.

The requirements do not apply if FDD macro-diversity is used.

4.2.2.2.1 Handover delay

Procedure delay for all procedures, that can command a hard handover, are specified in 3GPP TS 25.331 [9] section 11.5.

When the UE receives a RRC message that implies a handover with the activation time "now" or earlier than D_{handover} seconds from the end of the last TTI containing the RRC command, the UE shall be ready to start the transmission of the new uplink DPCH within D_{handover} s from the end of the last TTI containing the RRC command.

If the access is delayed to an indicated activation time later than D_{handover} seconds from the end of the last TTI containing the RRC command, the UE shall be ready to start the transmission of the new uplink DPCH at the designated activation time.

where:

D_{handover} equals the RRC procedure delay defined in TS 25.331 [9] Section 13.5.2 plus the interruption time stated in section 5.2.2.2 plus the time required for any kind of baseband or RF reconfiguration due to the change of the UTRAN mode.

4.2.2.2.2 Interruption time

The interruption time, i.e. the time between the end of the last TTI containing a transport block on the old DPCH and the time the UE starts transmission of the new uplink DPCH, shall be less than the value in table 4.3 There is different requirement on the interruption time depending on if the cell is known or not.

The definition of known cell can be found in section 4.2.1.2.2.

Table 4.3: 1.28 Mcps TDD/FDD interruption time

| cell in the handover command message | Maximum delay [ms] | |
|--------------------------------------|--------------------|--------------|
| | Known cell | Unknown cell |
| 1 | [100] | [350] |

The interruption time includes the interruption uncertainty when changing the timing from the old NTDD to the new FDD cell, which can be up to one frame (10ms) and the time required for measuring the downlink DPCH channel as stated in TS 25.214 section 4.3.1.2 into account.

The requirement in Table 4.2.2.1 for the unknown cell shall apply if the signal quality of the unknown cell is good enough for successful synchronisation with one attempt.

4.2.3 1.28 Mcps TDD/GSM Handover

In the early days of UMTS deployment it can be anticipated that the service area will not be as contiguous and extensive as existing second generation systems. It is also anticipated that UMTS network will be an overlay on the 2nd generation network and utilise the latter, in the minimum case, as a fall back to ensure continuity of service and maintain a good QoS as perceived by the user.

4.2.3.1 Introduction

The purpose of inter-RAT handover from UTRAN 1.28 Mcps TDD to GSM is to transfer a connection between the UE and UTRAN 1.28 Mcps TDD to GSM. The handover procedure is initiated from UTRAN with a RRC message (HANDOVER FROM UTRAN COMMAND). The procedure is described in TS 25.331 section 8.3.7.

4.2.3.2 Requirements

These requirements only apply to UE supporting GSM.

4.2.3.2.1 Handover delay

When the UE receives a RRC HANDOVER FROM UTRAN COMMAND with the activation time "now" or earlier than the value in Table 4.4 from the end of the last TTI containing the RRC command, the UE shall be ready to transmit (as specified in 3GPP 45.010 [12]) on the new channel the new RAT within the value in Table 4.4 from the last TTI containing the RRC command. If the access is delayed to an indicated activation time later than the value in Table 4.4 from the end of the last TTI containing the RRC command, the UE shall be ready to transmit (as specified in 3GPP TS 45.010 [12]) on the channel of the new RAT at the designated activation time.

The UE shall process the RRC procedures for the RRC HANDOVER FROM UTRAN COMMAND within 50 ms. If the activation time is used, it corresponds to the CFN of the UTRAN channel.

Table 4.4: 1.28 Mcps TDD/GSM handover –handover delay

| UE synchronisation status | handover delay [ms] |
|------------------------------------------------------------------------------------------------|---------------------|
| The UE has synchronised to the GSM cell before the HANDOVER FROM UTRAN COMMAND is received | 90 |
| The UE has not synchronised to the GSM cell before the HANDOVER FROM UTRAN COMMAND is received | 190 |

4.2.3.2.2 Interruption time

The interruption time, i.e. the time between the end of last TTI containing a transport block on the old channel and the time the UE is ready to transmit on the new channel, shall be less than the value in Table 4.5. The requirement in Table 4.5 for the case, that UE is not synchronised to the GSM cell before the HANDOVER FROM UTRAN COMMAND is received, is valid when the signal quality of the GSM cell is good enough for successful synchronisation with one attempt.

Table 4.5: TDD/GSM handover - interruption time

| Synchronisation status | Interruption time [ms] |
|------------------------------------------------------------------------------------------------|------------------------|
| The UE has synchronised to the GSM cell before the HANDOVER FROM UTRAN COMMAND is received | 40 |
| The UE has not synchronised to the GSM cell before the HANDOVER FROM UTRAN COMMAND is received | 140 |

4.2.4 Cell Re-selection in CELL_FACH

Note: Data in this section needs to be revised.

Cell re-selection, especially inter-frequency (TDD or FDD) and inter-system (GSM), in Cell_FACH state is still under discussion in WG4., due to possible loss of FACH data during reselection process.

4.2.4.1 Introduction

Common with TS 25.123 [3].

4.2.4.2 Requirements

Common with TS 25.123 [3].

4.2.4.2.1 Cell re-selection delay

Common with TS 25.123 [3].

4.2.4.2.1.1 All cells in the neighbour list belong to the same frequency

Common with TS 25.123 [3].

NOTE: The test parameter of this section will be found in B.2.4.1

4.2.4.2.1.2 The cells in the neighbour list belong to different frequencies

NOTE: This requirement should be reconsidered based on RAN2 decisions. the test of parameter of this section will be found in B.2.4.2.

The cell re-selection delay in CELL_FACH state shall be less than [x] seconds when the cells in the neighbour list belong to less than [x] frequencies.

NOTE: The test parameter of this section will be found in B.2.4.

4.2.5 Cell Re-selection in CELL_PCH

4.2.5.1 Introduction

Common with re-selection in idle mode.

4.2.5.2 Requirements

Same requirements as for cell re-selection in idle mode apply.

4.2.6 Cell Re-selection in URA_PCH

4.2.6.1 Introduction

Common with re-selection in idle mode.

4.2.6.2 Requirements

Same requirements as for cell re-selection in idle mode.

4.3 Dynamic Channel Allocation

4.3.1 Introduction

Common with 25.123

4.3.2 Implementation Requirements

Common with 25.123

4.3.3 Number of timeslots to be measured

The number of down link timeslots to be measured in the UE is broadcasted on the BCH in each cell. In general, the number of downlink timeslots in question will be less than [6], but in worst case the UE shall be capable to measure [6] downlink timeslots. In case of "simple UE [FFS] timeslots shall at least be measured.

4.3.3.1 Explanation

In NTDD there are 7 common timeslots and 3 special timeslots, in the 7 common timeslots Ts1 is always allocated to UL. So the number of downlink timeslots in question will be less than 6, in the worst case the UE shall be capable to measure 6 timeslots.

4.3.4 Measurement reporting delay

In order to save battery lifetime, in idle mode no measurements are performed for DCA. ISCP measurements are started at all establishments. Taking into account that the measured interference of the timeslots is preferable averaged over [FFS] frames, the measurement reporting delay in connecting phase shall not exceed [FFS] milliseconds.

4.4 Timing characteristics

4.4.1 Timing Advance (TA) Requirements

For 1.28 Mcps TDD the timing advance in the UE is adjusted by means of uplink synchronisation. For the random access procedure the node B commands the UE to adjust its synchronisation shift by means of signalling the received position of the UpPTS in the FPA CH. During the connection the node B measures the timing in the uplink and transmits a SS (Synchronisation Shift) command to the UE at least once per sub-frame.

These SS commands determined whether the UE synchronisation shift is either left unchanged, or adjusted 1 step up or 1 step down. The step size of the SS adjustment is $(k/8)T_c$ where $k (=1,2, \dots,8)$ is signalled by higher layer signalling.

4.4.1.1 Uplink synchronization control requirements for UE for 1.28 Mcps TDD option

Uplink synchronization control is the ability of the UE transmitter to adjust its TX timing in accordance with one or more SS commands received in the downlink.

4.4.1.1.1 Uplink synchronization control steps

The SS step is the change in UE transmission timing in response to a single SS command, SS_cmd, received by the UE.

4.4.1.1.1.1 Minimum requirement

The UE transmitter shall have the capability of changing the transmission timing with a step size of 1/8, 2/8, 3/8, ..., 1 chip according to the value of Δ_{SS} , $n=(1,2, \dots,14)$ time slot after the SS_cmd arrived (closed loop). For the open loop any step being a multiple of 1/8 chip has to be allowed.

- a) The minimum transmission timing step $\Delta_{SS,min}$ due to closed loop uplink synchronization control shall be within the range shown in Table 4.6.
- b) In case uplink synchronization control implies to perform a bigger step than the minimum step the UE shall perform the a multiple number of minimum steps m . Within the implementation grid of the applicable timing steps of the UE the step being closest to the required step should be executed.

Table 4.6: Uplink synchronisation control range

| SS_cmd | Uplink synchronisation control range for minimum step | |
|--------|-------------------------------------------------------|--------------------|
| | 1/8 chip step size | |
| | Lower | Upper |
| Up | 1/9 chip – 0.1 ppm | 1/7 chip + 0.1 ppm |
| Down | 1/9 chip – 0.1 ppm | 1/7 chip + 0.1 ppm |

4.4.1.1.2 Timing Advance (T_{ADV}) for 1.28 Mcps TDD

This measurement refers to TS 25.225 subsection 5.1.14.

4.4.1.1.2.1 Accuracy requirements

Table 4.7

| Parameter | Unit | Accuracy | Conditions |
|----------------|--------------|-----------|-----------------|
| | | | Range [chips] |
| Timing Advance | chips period | +/- 0.125 | 0, ..., 255.875 |

4.4.1.1.2.2 Range/mapping

The reporting range for *Timing Advance* is from 0 ... 255.875 chips.

In table 4.8 the mapping of the measured quantity is defined. The signalling range may be larger than the guaranteed accuracy range.

Table 4.8

| Reported value | Measured quantity value | Unit |
|---------------------|-----------------------------------------------|------|
| TIMING_ADVANCE_0000 | Timing Advance < 0 | chip |
| TIMING_ADVANCE_0001 | $0 \leq \text{Timing Advance} < 0.125$ | chip |
| TIMING_ADVANCE_0002 | $0.125 \leq \text{Timing Advance} < 0.25$ | chip |
| ... | ... | ... |
| TIMING_ADVANCE_1024 | $127.875 \leq \text{Timing Advance} < 128$ | chip |
| ... | ... | ... |
| TIMING_ADVANCE_2045 | $255.625 \leq \text{Timing Advance} < 255.75$ | chip |
| TIMING_ADVANCE_2046 | $255.75 \leq \text{Timing Advance} < 255.875$ | chip |
| TIMING_ADVANCE_2047 | $255.875 \leq \text{RX Timing Advance}$ | chip |

NOTE: This measurement can be used for timing advance (synchronisation shift) calculation for uplink synchronisation or location services.

4.4.1.1.2.2.1 Explanation difference

In 3.84 Mcps TDD timing advance control is carried out by means of higher layer signalling: The network transmits a highly protected timing advance command containing the total timing advance and the UE executes it. Consequently the network can be sure of the timing advance applied by the UE.

In 1.28 Mcps TDD the network transmits SS symbols giving commands like a step up or down or no change at all in every sub-frame. These SS symbols are not protected by a special channel coding including CRC etc. Consequently, the network cannot know whether its commands have been executed or not. Thus, the network cannot obtain the timing advance of the UE by tracking its SS commands. Instead, the UE has to measure its timing advance and transmit it to the network by means of the timing advance measurement.

4.4.2 Cell synchronisation accuracy

Common with 3.84 Mcps TDD option.

4.4.2.0 Explanation

Considering intersystem compatibility, cell synchronisation accuracy is the same as 3.84 Mcps TDD option.

4.4.2.1 Definition

(void)

4.4.2.2 Minimum Requirements

(void)

4.5 UE Measurements Procedures

4.5.1 Measurements in CELL_DCH State

The monitor mechanism in this state is ffs for 1.28 chip rate TDD.

4.5.1.0 Explanation

This section contains requirements on the UE regarding measurement reporting in CELL_DCH State. Because of the difference between the frame structure of 1.28 Mcps and that of 3.84 Mcps, the idle time slots which can be used for monitoring will be different, hence the detail of this subclause would be different compared with 3.84 Mcps.

4.5.1.1 Introduction

(void)

4.5.1.2 Requirements

(void)

4.5.2 Measurements in CELL_FACH State

Commons with 3.84 Mcps TDD.

4.5.2.0 Explanation

The section describes the requirements on the UE regarding measurement reporting in CELL_FACH state. The requirements independent with bandwidth and chip rate should be the same. Hence the contents need no modification.

4.5.2.1 Introduction

(void)

4.5.2.2 Requirements

(void)

4.6 Measurements Performance Requirements

4.6.1 Measurements Performance for UE

4.6.1.1 Performance for UE Measurements in Downlink (RX)

4.6.1.1.1 P-CCPCH RSCP (1.28 Mcps TDD)

Common with 3.84 Mcps TDD.

4.6.1.1.1.1 Explanation

The result of this measurement is not energy and it is independent with the bandwidth, so there should not be modification.

4.6.1.1.2 CPICH Measurements (FDD)

Common with 3.84 Mcps TDD.

4.6.1.1.3 Timeslot ISCP

Common with 3.84 Mcps TDD.

4.6.1.1.3.1 Explanation

The result of this measurement is not energy and it is independent with the bandwidth, so there should not be modification.

4.6.1.1.4 UTRA carrier RSSI

Common with 3.84 Mcps TDD.

4.6.1.1.4.1 Explanation

This measurement relies on the signal-detecting algorithm which independent with the bandwidth and chip rate, so it needs no modification.

4.6.1.1.5 GSM carrier RSSI

Common with 3.84 Mcps TDD.

4.6.1.1.5.1 Explanation

This measurement relies on GSM, so it needs no modification.

4.6.1.1.6 SIR

Common with 3.84 Mcps TDD.

4.6.1.1.6.1 Explanation

This measurement mainly used to meet the requirement of service performance which independent with the bandwidth and chip rate, so there should be no modification.

4.6.1.1.7 Transport channel BLER

Common with 3.84 Mcps TDD.

4.6.1.1.7.1 Explanation

This measurement is mainly used to meet the requirement of service performance which independent with the bandwidth and chip rate, so there should be no modification.

4.6.1.1.8 SFN-SFN observed time difference

The measurement period for CELL_DCH state can be found in section 4.5.

4.6.1.1.8.1 Accuracy requirements

Table 4.9: SFN-SFN observed time difference accuracy

| Parameter | Unit | Accuracy | Conditions |
|----------------------------------|------|--------------------------------------------|------------|
| | | | Io [dBm] |
| SFN-SFN observed time difference | Chip | +/-0,5 for type 1 but +/- 0.125 for type 2 | -94...-50 |

4.6.1.1.8.2 Range/mapping

The reporting range for *SFN-SFN observed time difference type 1* is from 0 ... 3276800 chip.

In table 4.10 mapping of the measured quantity is defined. Signalling range may be larger than the guaranteed accuracy range.

Table 4.10

| Reported value | Measured quantity value | Unit |
|--------------------------|-------------------------------------------------------------------------|------|
| T1_SFNN-SFN_TIME_000000 | $0 \leq \text{SFN-SFN observed time difference type 1} < 1$ | chip |
| T1_SFNN-SFN_TIME_000001 | $1 \leq \text{SFN-SFN observed time difference type 1} < 2$ | chip |
| T1_SFNN-SFN_TIME_000002 | $2 \leq \text{SFN-SFN observed time difference type 1} < 3$ | chip |
| ... | ... | ... |
| T1_SFNN-SFN_TIME_3276797 | $3276797 \leq \text{SFN-SFN observed time difference type 1} < 3276798$ | chip |
| T1_SFNN-SFN_TIME_3276798 | $3276798 \leq \text{SFN-SFN observed time difference type 1} < 3276799$ | chip |
| T1_SFNN-SFN_TIME_3276799 | $3276799 \leq \text{SFN-SFN observed time difference type 1} < 3276800$ | chip |

The reporting range for *SFN-SFN observed time difference type 2* is from $-6400 \dots +6400$ chip.

In table 4.11 mapping of the measured quantity is defined. Signalling range may be larger than the guaranteed accuracy range.

Table 4.11

| Reported value | Measured quantity value | Unit |
|------------------------|---------------------------------------------------------------------------|------|
| T2_SFNN-SFN_TIME_00000 | $\text{SFN-SFN observed time difference type 2} < -6390,00$ | chip |
| T2_SFNN-SFN_TIME_00001 | $-6390,00 \leq \text{SFN-SFN observed time difference type 2} < -6399,75$ | chip |
| T2_SFNN-SFN_TIME_00002 | $-6399,75 \leq \text{SFN-SFN observed time difference type 2} < -6399,50$ | chip |
| ... | ... | ... |
| T2_SFNN-SFN_TIME_51199 | $6399,50 \leq \text{SFN-SFN observed time difference type 2} < 6399,75$ | chip |
| T2_SFNN-SFN_TIME_51200 | $6399,75 \leq \text{SFN-SFN observed time difference type 2} < 6400,00$ | chip |
| T2_SFNN-SFN_TIME_51201 | $6400,00 \leq \text{SFN-SFN observed time difference type 2}$ | chip |

4.6.1.1.8.3 Explanation difference

In 1.28 Mcps TDD there are 12800chips per frame while in 3.84 Mcps TDD there are 38400chips. According to this chip number difference, the observed time difference range in type 1 should be changed correspondingly.

There are 3 kind of special time slot (DwPTS, UpPTS and GP) in 1.28 Mcps TDD frame structure (see section 7.2.1 'frame structure' in TR 25.928). When calculation the SFN-SFN observed time difference in type 2, it needs to consider the position and affection of these 3 special time slots.

Let us suppose:

T_{RxTSi} : time of start of timeslot#0 received of the serving TDD cell i.

T_{RxTSk} : time of start of timeslot#0 received from the target UTRA cell k that is closest in time to the start of the timeslot of the serving TDD cell i.

SFN-SFN observed time difference = $T_{\text{RxTSk}} - T_{\text{RxTSi}}$, in chips, which means to calculate the the time difference of the start position of the current frame in cell i to the closest starting position of one frame in cell k.

Editor Note: Here in type 2 we only consider to measure the difference of two cells of 1.28 Mcps TDD. The measurement method is like that in TS 25.215. In type 2 measurement of TS 25.215, it measures the time difference of the start position of the P-CPICH of two cells. That is just something like in 1.28 Mcps TDD.

4.6.1.1.9 Observed time difference to GSM cell

Common with 3.84 Mcps TDD.

4.6.1.1.9.1 Explanation

For different systems, the measurement that is used to realize the compatibility should be the same. So it is independent with bandwidth and chip rate and there should be no modification.

4.6.1.1.10 UE GPS Timing of Cell Frames for LCS

Common with 3.84 Mcps TDD.

4.6.1.1.10.1 Explanation

The GPS timing of cell frames should be the same for different systems having LCS, so it needs no modification.

4.6.1.1.11 SFN-CFN observed time difference

Common with 3.84 Mcps TDD.

4.6.1.1.11.1 Explanation

For the measurement used for the interwork between cells, which belong to the same system or different systems, should be the same and independent with bandwidth and chip rate. So it needs no modification.

4.6.1.2 Performance for UE Measurements in Uplink (TX)

4.6.1.2.1 UE transmitted power

Common with 3.84 Mcps TDD.

4.6.1.2.1.1 Explanation

The *UE transmitted power* is represented by energy density and it is independent with the bandwidth, so there should not be modification.

4.6.2 Measurements Performance for UTRAN

4.6.2.1 Performance for UTRAN Measurements in Uplink (RX)

4.6.2.1.1 RSCP

Common with 3.84 Mcps TDD option.

4.6.2.1.2 Timeslot ISCP

Common with 3.84 Mcps TDD option

4.6.2.1.3 RSSI

Common with 3.84 Mcps TDD option

4.6.2.1.4 SIR

Common with 3.84 Mcps TDD option

4.6.2.1.5 Transport Channel BER

Common with 3.84 Mcps TDD option

4.6.2.1.6 RX Timing Deviation

The definition of RX Timing Deviation here is common with 3.84 Mcps but only accuracy and range are different between two TDD mode.

4.6.2.1.6.1 Accuracy requirements

Table 4.12

| Parameter | Unit | Accuracy | Conditions |
|---------------------|--------------|-----------|----------------|
| | | | Range [chips] |
| RX Timing Deviation | chips period | +/- 0.125 | -128, ..., 128 |

4.6.2.1.6.2 Range/mapping

The reporting range for *RX Timing Deviation* is from -128 ... 128 chips.

In table 4.13 mapping of the measured quantity is defined. Signaling range may be larger than the guaranteed accuracy range.

Table 4.13

| Reported value | Measured quantity value | Unit |
|------------------|-------------------------------------------|------|
| RX_TIME_DEV_0001 | RX Timing Deviation < -128,000 | chip |
| RX_TIME_DEV_0002 | -128,000 ≤ RX Timing Deviation < -127,875 | chip |
| RX_TIME_DEV_0003 | -127,875 ≤ RX Timing Deviation < -127,750 | chip |
| ... | ... | ... |
| RX_TIME_DEV_1024 | 000,000 ≤ RX Timing Deviation < 000,125 | chip |
| ... | ... | ... |
| RX_TIME_DEV_2046 | 127,750 ≤ RX Timing Deviation < 127,875 | chip |
| RX_TIME_DEV_2047 | 127,875 ≤ RX Timing Deviation < 128,000 | chip |
| RX_TIME_DEV_2048 | 128,000 ≤ RX Timing Deviation | chip |

NOTE: This measurement can be used for timing advance (synchronisation shift) calculation for uplink synchronisation or location services.

4.6.2.1.6.3 Explanation difference

In 3.84 Mcps TDD the 'RX Timing Deviation' measurement is only needed to report to the higher layer for timing advance calculation or location services. It does not need to measure this value continuously.

While in 1.28 Mcps TDD this measurement is not only reported to higher layer, but also served as a physical signal ('Synchronization Shift' or 'SS') to keep uplink synchronization. It needs to be refreshed every 5ms (every sub-frame). The resolution requirement is 1/8 chip as described in section 10.2 'Timing Advance' of TR25.928 [10].

Because SS is served as a physical layer signal in 1.28 Mcps TDD, it needs to consider how to map this value onto data burst. When in random access procedure the SS control step should have a large range to quickly establish the uplink synchronization. While in normal working procedure to maintain the uplink synchronization it should use as little bits as possible to reduce the affection to the DPCH capacity. These considerations are described in section 10.2 'Timing Advance' and section 8.2.2 'Coding of Synchronization Shift' of TR25.928 [10].

Others section of 4.6.2.1 are common with 25.123 [3]

4.6.2.1.7 SYNC-UL Timing Deviation for 1.28 Mcps

This measurement refers to TS 25.225 [13] subsection 5.2.8.1.

4.6.2.1.7.1 Accuracy requirements

Table 4.14

| Parameter | Unit | Accuracy | Conditions |
|--------------------------|--------------|-----------|-----------------|
| | | | Range [chips] |
| SYNC-UL Timing Deviation | chips period | +/- 0.125 | 0, ..., 255.875 |

4.6.2.1.7.2 Range/mapping

The reporting range for *SYNC-UL Timing Deviation* is from 0 ... 255.875 chips.

In table 4.15 the mapping of the measured quantity is defined. Signaling range may be larger than the guaranteed accuracy range.

Table 4.15

| Reported value | Measured quantity value | Unit |
|-----------------------|---------------------------------------------------------|------|
| SYNC_UL_TIME_DEV_0000 | SYNC-UL Timing Deviation < 0 | chip |
| SYNC_UL_TIME_DEV_0001 | $0 \leq \text{SYNC-UL Timing Deviation} < 0.125$ | chip |
| SYNC_UL_TIME_DEV_0002 | $0.125 \leq \text{SYNC-UL Timing Deviation} < 0.25$ | chip |
| ... | ... | ... |
| SYNC_UL_TIME_DEV_1024 | $127.875 \leq \text{SYNC-UL Timing Deviation} < 128$ | chip |
| ... | ... | ... |
| SYNC_UL_TIME_DEV_2045 | $255.625 \leq \text{SYNC-UL Timing Deviation} < 255.75$ | chip |
| SYNC_UL_TIME_DEV_2046 | $255.75 \leq \text{SYNC-UL Timing Deviation} < 255.875$ | chip |
| SYNC_UL_TIME_DEV_2047 | $255.875 \leq \text{SYNC-UL Timing Deviation}$ | chip |

NOTE: This measurement can be used for timing advance (synchronisation shift) calculation for uplink synchronisation or location services.

4.6.2.1.7.3 Explanation difference

In 1.28 Mcps TDD there is a two step approach for the random access procedure. In the first step the UpPCH is transmitted by the UE. The node B received the UpPCH and responds with the FPACH which contains the received position of the SYNC-UL sequence. This allows the UE to adjust its timing advance for the PRACH in order to allow the node B to receive the PRACH synchronously with the other physical channels in the time slot carrying the PRACH.

As there is a special time slot of random access in 3.84 Mcps TDD there is no need for this measurement in 3.84 Mcps TDD.

4.6.2.2 Performance for UTRAN Measurements in Downlink (TX)

4.6.2.2.1 Transmitted carrier power

Common with 3.84 Mcps TDD option.

4.6.2.2.1.1 Explanation

These parameters in this section are not energy ,so they are independent with bandwidth . There need not to any change compare with the 3.84 Mcps TDD option.

4.6.2.2.2 Transmitted code power

Common with 3.84 Mcps TDD option.

4.6.2.2.2.1 explanation

These parameters in this section are not energy ,so they are independent with bandwidth. There need not to any change compare with the 3.84 Mcps TDD option.

4.7 FPACH physical layer information field definition (1.28 Mcps TDD)

1.28 Mcps TDD introduces the FPACH (Forward Physical Access CHannel) which carries physical layer information. Two of these information fields are the 'received starting position of the UpPCH' (Up link Pilot CHannel) and the

‘transmit power level command for the RACH message’. Both information fields are directly (received starting position of the UpPCH) or can be indirectly (transmit power level command for the RACH message) derived from measurements but are no measurements themselves.

4.7.0 Explanation difference

In 1.28 Mcps TDD the random access procedure follows a two step approach. After the 1st step (UpPCH) the FPACH also carries the information fields related to the initialisation of uplink synchronisation control and uplink power control for the PRACH (2nd step). This is ensuring that the PRACH can be transmitted in the time slots carrying the DPCH.

4.7.1 Received starting position of the UpPCH (UpPCH_{POS}) (1.28 Mcps TDD)

4.7.1.1 Range/mapping

Table 4.16

| | |
|---------------|-------------------------------------------------------------------------------------------------------------------------------------------------------------------------------------------------------------------------------------------------------------------------------------------------------------------------------------------------------------------------------------------------------------------------------------------------------------------------------------------------------------------------------------------------------------------------------------------------------------------------------------------------------------------------------------------------|
| Range/mapping | UpPCH _{POS} FIELD is given with a resolution of 1/8 chip with the range [0,255.875] chip. UpPCH _{POS} FIELD shall be transmitted in the FPACH where: UpPCH _{POS} FIELD_LEV_0000: UpPCH _{POS} < 0 chip UpPCH _{POS} FIELD_LEV_0001: 0 chip ≤ UpPCH _{POS} < 0.125 chip UpPCH _{POS} FIELD_LEV_0002: 0.125 chip ≤ UpPCH _{POS} < 0.25 chip ... UpPCH _{POS} FIELD_LEV_2045: 255.625 chip ≤ UpPCH _{POS} < 255.75 chip UpPCH _{POS} FIELD_LEV_2046: 255.75 chip ≤ UpPCH _{POS} < 255.875 chip UpPCH _{POS} FIELD_LEV_2047: 255.875 chip ≤ UpPCH _{POS} |
|---------------|-------------------------------------------------------------------------------------------------------------------------------------------------------------------------------------------------------------------------------------------------------------------------------------------------------------------------------------------------------------------------------------------------------------------------------------------------------------------------------------------------------------------------------------------------------------------------------------------------------------------------------------------------------------------------------------------------|

4.7.1.2 Accuracy requirements

Table 4.17

| Parameter | Unit | Accuracy | Conditions |
|-----------------------------------------|--------------|-----------|-----------------|
| | | | Range [chips] |
| Received starting position of the UpPCH | chips period | +/- 0.125 | 0, ..., 255.875 |

4.7.2 Transmit Power Level Command for the RACH message (1.28 Mcps TDD)

4.7.2.1 Range/mapping

Table 4.18

| | |
|---------------|-----------------------------------------------------------------------------------------------------------------------------------------------------------------------------------------------------------------------------------------------------------------------------------------------------------------------------------------------------------------------------------------------------------------------------------------------------------------------------------------------------------------------------------------------------------------------------------------------------------------------------------------------------------------------------------------------------------------------------------------------------------------------------------------------------------------------------------------------------------------------------------------------------------------------|
| Range/mapping | <p>$PRX_{PRACH,des}$ FIELD is given with a resolution of 0.5 dB with the range [-120,-80] dBm.</p> <p>$PRX_{PRACH,des}$ FIELD shall be transmitted in the FPACH where:</p> <p>$PRX_{PRACH,des}$ FIELD_LEV_00: $PRX_{PRACH,des} < -120$ dBm</p> <p>$PRX_{PRACH,des}$ FIELD_LEV_01: -120 dBm $\leq PRX_{PRACH,des} < -119.5$ dBm</p> <p>$PRX_{PRACH,des}$ FIELD_LEV_02: -119.5 dBm $\leq PRX_{PRACH,des} < -119$ dBm</p> <p>...</p> <p>$PRX_{PRACH,des}$ FIELD_LEV_78: -81 dBm $\leq PRX_{PRACH,des} < -80.5$ dBm</p> <p>$PRX_{PRACH,des}$ FIELD_LEV_79: -80.5 dBm $\leq PRX_{PRACH,des} < -80$ dBm</p> <p>$PRX_{PRACH,des}$ FIELD_LEV_80: -80 dBm $\leq PRX_{PRACH,des}$</p> |
|---------------|-----------------------------------------------------------------------------------------------------------------------------------------------------------------------------------------------------------------------------------------------------------------------------------------------------------------------------------------------------------------------------------------------------------------------------------------------------------------------------------------------------------------------------------------------------------------------------------------------------------------------------------------------------------------------------------------------------------------------------------------------------------------------------------------------------------------------------------------------------------------------------------------------------------------------|

4.7.2.2 Accuracy requirements

Since this is a desired RX power at the node B and this is no measured value and the derivation of this value in the node B is implementation specific, accuracy requirements are not applicable.

5 UE Radio Transmission and Reception

5.1 Frequency bands and channel arrangement

5.1.1 General

The information presented in this section is based on a chip rate of 1.28 Mcps.

5.1.2 Frequency bands

Common with 3.84 Mcps TDD option.

5.1.3 TX–RX frequency separation

5.1.3.1 Description

No TX-RX frequency separation is required as Time Division Duplex (TDD) is employed. Each subframe of 1.28 Mcps TDD consists of 7 main timeslots (TS0 ~ TS6) where TS0 (before DL to UL switching point) are always allocated DL, the timeslots (at least the first one) before the switching point (vice versa) are allocated UL and the timeslots after the switching point (vice versa) are allocated DL.

5.1.3.2 Explanation of difference

The frame structure for 3.84 Mcps TDD and 1.28 Mcps TDD is different. For 3.84 Mcps TDD, each TDMA frame consists of 15 timeslots where each timeslot can be allocated to either transmit or receive.

5.1.4 Channel arrangement

5.1.4.1 Channel spacing

5.1.4.1.1 Background

The chip rate is 1.28 Mcps with a roll-off factor of 0.22, therefore the occupied bandwidth is 1.6MHz. It is just nominal 1.6MHz, and it is also flexible to adjust the channel raster step 200kHz to narrow as 1.4MHz for strict requirement situations if needed.

5.1.4.1.2 Channel spacing

The channel spacing for 1.28 Mcps chip rate option is 1.6MHz.

5.1.4.2 Channel raster

Common with 3.84 Mcps TDD option.

5.1.4.3 Channel number

Common with 3.84 Mcps TDD option.

5.2 Transmitter characteristics

5.2.1 General

Common with 3.84 Mcps TDD option.

5.2.2 Transmit power

5.2.2.1 User Equipment maximum output power

Common with 3.84 Mcps TDD option.

5.2.3 UE frequency stability

Common with 3.84 Mcps TDD option.

5.2.4 Output power dynamics

Power control is used to limit the interference level.

5.2.4.1 Open loop power control

Open loop power control is the ability of the UE transmitter to sets its output power to a specific value. The open loop power control tolerance is given in Table 5.1

5.2.4.1.1 Minimum requirement

The UE open loop power is defined as the average power in a timeslot or ON power duration, whichever is available, and they are measured with a filter that has a Root-Raised Cosine (RRC) filter response with a roll off $\alpha = 0.22$ and a bandwidth equal to the chip rate.

Table 5.1: Open loop power control

| | |
|--------------------|-------------|
| Normal conditions | ± 9 dB |
| Extreme conditions | ± 12 dB |

5.2.4.2 Closed loop power control in the uplink

Closed loop power control in the Uplink is the ability of the UE transmitter to adjust its output power in accordance with one or more TPC commands received in the downlink.

5.2.4.2.1 Power control steps

The power control step is the change in the UE transmitter output power in response to a single TPC command, TPC_cmd, arrived at the UE.

5.2.4.2.1.1 Minimum requirement

The UE trans mitter shall have the capability of changing the output power with a step size of 1, 2 and 3 dB according to the value of Δ_{TPC} or $\Delta_{\text{RP-TPC}}$, in the slot immediately after the TPC_cmd can be arrived.

- a) The transmitter output power step due to closed loop power control shall be within the range shown in Table 5.2
- b) The transmitter average output power step due to closed loop power control shall be within the range shown in Table 5.3. Here a TPC_cmd group is a set of TPC_cmd values derived from a corresponding sequence of TPC commands of the same duration.

The closed loop power is defined as the relative power differences between averaged power of original (reference) timeslot and averaged power of the target timeslot without transient duration. They are measured with a filter that has a Root-Raised Cosine (RRC) filter response with a roll off $\alpha = 0.22$ and a bandwidth equal to the chip rate.

Table 5.2: Transmitter power control range

| TPC_cmd | Transmitter power control range | | | | | |
|---------|---------------------------------|---------|----------------|-------|----------------|---------|
| | 1 dB step size | | 2 dB step size | | 3 dB step size | |
| | Lower | Upper | Lower | Upper | Lower | Upper |
| Up | +0.5 dB | +1.5 dB | +1 dB | +3 dB | +1.5 dB | +4.5 dB |
| Down | -0.5 dB | -1.5 dB | -1 dB | -3 dB | -1.5 dB | -4.5 dB |

Table 5.3: Transmitter average power control range

| TPC_cmd group | Transmitter power control range after 10 equal TPC_cmd groups | | | | | |
|---------------|---------------------------------------------------------------|--------|----------------|--------|----------------|--------|
| | 1 dB step size | | 2 dB step size | | 3 dB step size | |
| | Lower | Upper | Lower | Upper | Lower | Upper |
| Up | +8 dB | +12 dB | +16 dB | +24 dB | +24 dB | +36 dB |
| Down | -8 dB | -12 dB | -16 dB | -24 dB | -24 dB | -36 dB |

5.2.4.3 Minimum transmit output power

The minimum controlled output power of the UE is when the power control setting is set to a minimum value. This is when both the closed loop and open loop power control indicate a minimum transmit output power is required.

5.2.4.3.1 Minimum requirement

The minimum transmit power is defined as an averaged power in a time slot measured with a filter that has a Root-Raised Cosine (RRC) filter response with a roll off $\alpha = 0.22$ and a bandwidth equal to the chip rate. The minimum transmit power shall be better than -49 dBm/1.28MHz.

5.2.4.3.2 Rationale

For the power control issue, the open loop and closed loop power control procedure is introduced in 1.28 Mcps TDD option [4], basically has the similar requirements as that of UTRA FDD.

The minimum transmit output power is basically kept in line with 3.84 Mcps TDD mode, just considering the RRC measurement filter bandwidth is 1/3 of 3.84 Mcps TDD mode, so the figure is scaleable change accordingly.

5.2.4.4 Out-of-synchronisation handling of output power

The UE shall monitor the DPCH quality in order to detect a loss of the signal on Layer 1. The thresholds Q_{out} and Q_{in} specify at what DPCH quality levels the UE shall shut its power off and when it may turn its transmitter on, respectively. The thresholds are not defined explicitly, but are defined by the conditions under which the UE shall shut its transmitter off and turn it on, as stated in this clause.

5.2.4.4.1 Requirement

The parameters in Table 5.4 are defined using the DL reference measurement channel (12.2) kbps specified in Annex C.2.1, where the CRC bits are replaced by data bits, and with static propagation conditions.

Table 5.4: DCH parameters for test of Out-of-synch handling

| Parameter | Unit | Value |
|-------------------------------------|--------------|--------------|
| \hat{I}_{or}/I_{oc} | dB | -1 |
| I_{oc} | dBm/1.28 MHz | -60 |
| $\frac{\Sigma DPCH_{-}E_c}{I_{or}}$ | dB | See figure 1 |
| Information Data Rate | kbps | 12.2 |
| TFCI | - | On |

The conditions for when the UE shall shut its transmitter on and when it shall turn it on are defined by the parameters in Table 5.4 together with the DPCH power level as defined in Figure 5. 1.

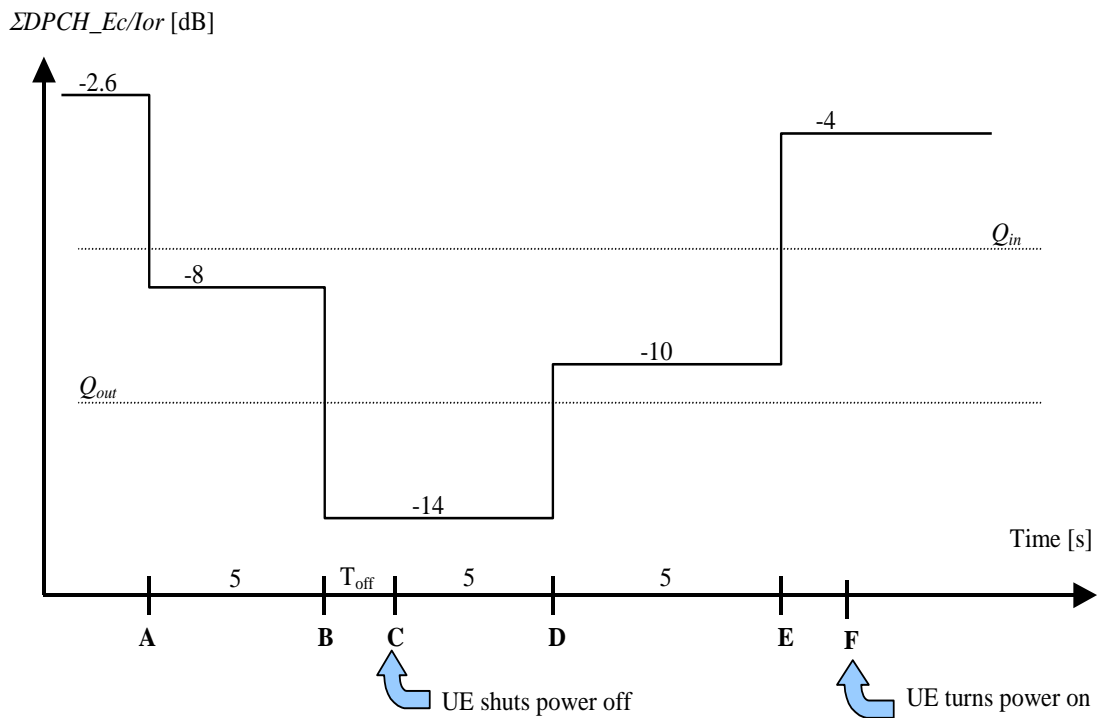

Figure 5.1: Conditions for out-of-synch handling in the UE. The indicated thresholds Q_{out} and Q_{in} are only informative.

The requirements for the UE are that

- The UE shall not shut its transmitter off before point B.
- The UE shall shut its transmitter off before point C, which is $T_{off} = 200$ ms after point B
- The UE shall not turn its transmitter on between points C and E.
- The UE shall turn its transmitter on before point F, which is $T_{on} = 200$ ms after Point E.

5.2.4.4.2 Rationale

A test procedure was introduced for the case of testing the UE ability to shut down its power if the received power is below a certain limit. The power will be varied at the input of the 3.84 Mcps TDD Option UE according to the following figure:

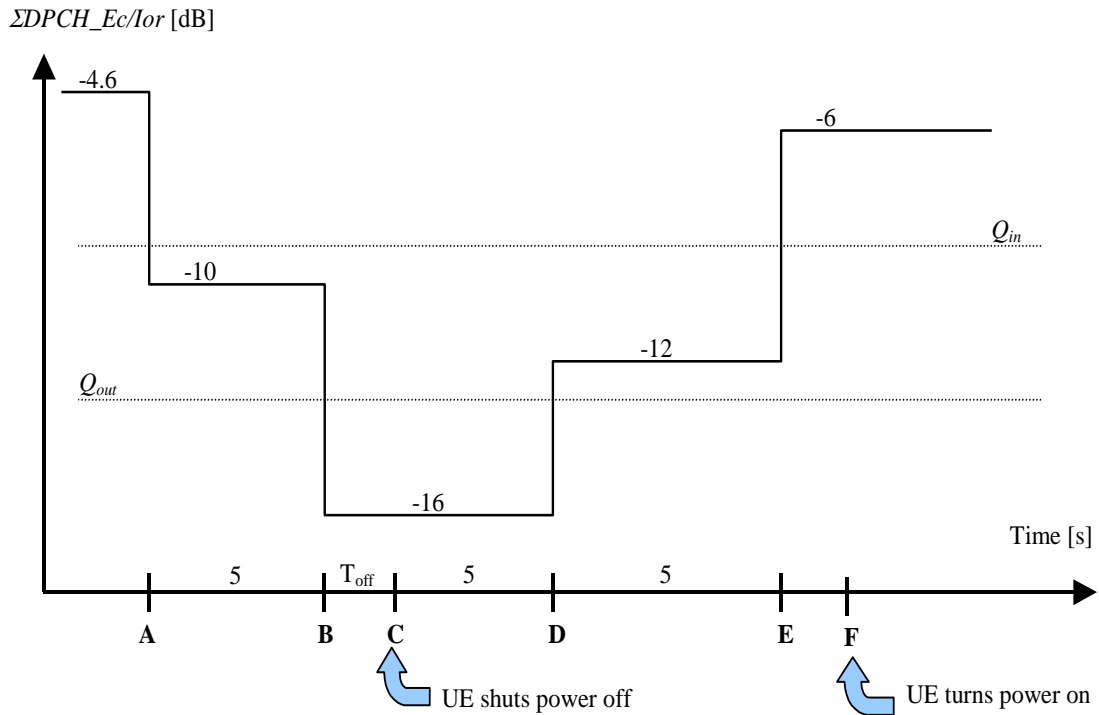

Figure 5.2: Conditions for out-of-synch handling in the 3.84 Mcps TDD Option UE.
The indicated thresholds Q_{out} and Q_{in} are only informative.

This entry point of the power is the sensitivity limit of the 3.84 Mcps TDD Option UE. According to the link level simulations in TR25.942 [6] the UE needs a $I_{OR}/I_{OC}=0.4\text{dB}$ ($-1.6\text{dB}+2\text{dB}$ margin) at $DPCH_E_C/I_{OR}=-6\text{dB}$ for the required performance in case of 12.2kBit/sec service and AWGN propagation. That means also that the required $DPCH_E_C/I_{OC}=-5.6\text{dB}$. In the test case of “out-of-sync handling” the test shall be carried out with $I_{OR}/I_{OC}=-1\text{dB}$. That means if the UE shall operate at the same BER limit described above the $DPCH_E_C/I_{OR}$ shall be -4.6dB . ($DPCH_E_C/I_{OR} = (DPCH_E_C/I_{OC}) * (I_{OC}/I_{OR}) = -5.6\text{dB} + 1\text{dB} = -4.6\text{dB}$).

Doing the same calculations for the 1.28 Mcps TDD Option UE, the required $I_{OR}/I_{OC}=3.2\text{dB}$ ($1.2\text{dB}+2\text{dB}$ margin) at $DPCH_E_C/I_{OR}=-7\text{dB}$. That means also that the required $DPCH_E_C/I_{OC}=-3.8\text{dB}$. Setting the $I_{OR}/I_{OC}=-1\text{dB}$ for the test case the required $DPCH_E_C/I_{OR} = (DPCH_E_C/I_{OC}) * (I_{OC}/I_{OR}) = -3.8\text{dB} + 1\text{dB} = -2.8\text{dB}$. That is the entry point in the test case for the 1.28 Mcps TDD Option UE. A **-2.6 dB** will be proposed for this entry point level to have a convenient scaling level from 3.84 Mcps TDD Option to 1.28 Mcps TDD Option.

5.2.5 Transmit ON/OFF power

5.2.5.1 Transmit OFF power

The transmit OFF power state is when the UE does not transmit. This parameter is defined as the maximum output transmit power within the channel bandwidth when the transmitter is OFF.

5.2.5.1.1 Minimum Requirement

The requirement for transmit OFF power shall be better than -65 dBm measured with a filter that has a Root-Raised Cosine (RRC) filter response with a roll off $\alpha=0.22$ and a bandwidth equal to the chip rate.

5.2.5.1.2 Rational

In TDD mode, various users are transmitting and receiving on the same frequency band. A maximum transmit output power in the transmitter idle mode has to be defined not to affect other nearby receiving mobiles or BSs. Then received power due to a nearby UE has to be required below the noise floor.

The maximum acceptable transmit off power level can be represented as follows

$$\text{Transmit off power level [dBm]} < -174 [\text{dBm/Hz}] + 10\log(1.28\text{M[Hz]}) + \text{NF} + \text{MCL},$$

Assuming a minimum coupling loss (MCL) of 40 dB between mobiles and a noise figure (NF) of 9 dB for the UE, then we can get:

$$\text{Transmit off power level [dBm]} < -113 + 9 + 40 = -64 \text{ dBm},$$

I.e., the transmit off power level has to be below -64 dBm.

A selected value of -65 dBm leads to minor degradation in the receiver sensitivity, and also leads to well compatible with 3.84 Mcps TDD option.

5.2.5.2 Transmit ON/OFF Time mask

The time mask transmit ON/OFF defines the tramping time allowed for the UE between transmit OFF power and transmit ON power.

5.2.5.2.1 Minimum Requirement

The transmit power level versus time shall meet the mask specified in figure 5.3, where the transmission period refers to the burst without guard period for a single transmission slot, and to the period from the beginning of the burst in the first transmission slot to the end of the burst without guard period in the last transmission timeslot for consecutive transmission slots.

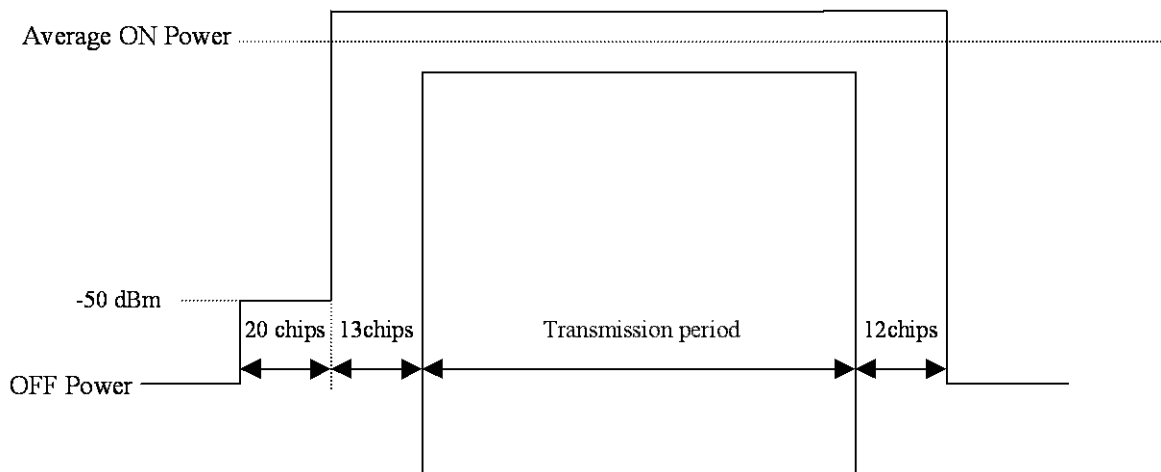

Figure 5.3: Transmit ON/OFF template

5.2.5.2.1 Rationales

A time mask should be included for relevant UE transmit power on/off scenarios. Requirements should be specified to limit impact on system performance and allow reasonable implementation.

To limit impact on the system performance, the time allowed for ramping should be small compared to the time period of continuous transmission. From implementation point of view ramping time should be as long as possible. Shorter ramping time will introduce more ripples in output power.

Depending on the size of a TDD cell it is required for the received signals from different users at the Node B be advanced in timing.

As described, there are four key parameters that have to be taken into account when specifying transmit time mask, especially when considering ramping during a guard period.

5.2.5.2.1.1 Timing advance

For large cells, the timing advance is necessary, otherwise channel estimation will not work properly. Currently, a cell radius of having 8.7km for rural/macro case is assumed for illustration. This corresponds to round trip delay of 58μs. 29us for timing advance is expected..

5.2.5.2.2 Switching time

Based on state-of-art semiconductor technology, about 10us of switching time could be expected to easy to handle and implementation in UE side.

5.2.5.2.3 Delay spread

Under typical urban fading conditions, delay spread is mostly not greater than 3.125 μs (4chips)

5.2.5.2.4 BS Synchronization accuracy

The timing error of BSs synchronized to each other shall be less than 3.125us (4chips)

The figure 5.4 illustrates a situation,

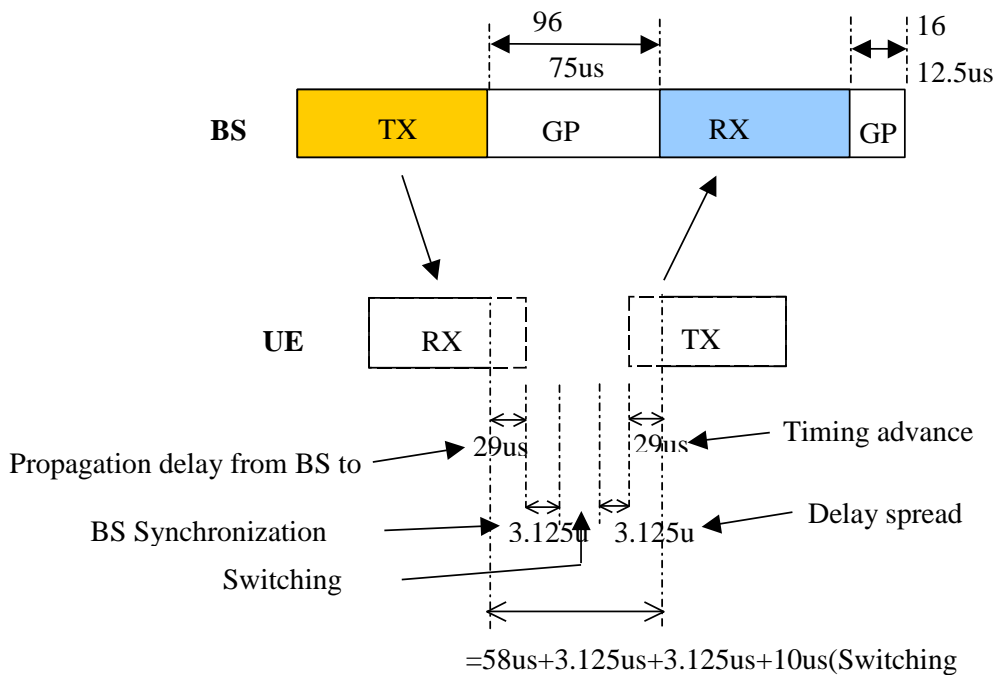

Figure 5.4: Cell with timing advance

Based on above analysis and consideration, the 13chips(10us) period in 1.28 Mcps TDD UE is feasible for ramp up.

Considering the easy implementation aspects, a 20chips(about 15us) transient time is considered for ramp up when transmitter on.

For the ramp down transition in 1.28 Mcps TDD, the BS Synchronization error should be considered, there are 12chips(12.5-3.125=9.375us) period is proposed for TX ramp down. It is reasonable to implementation based on the state-of-art semiconductor level.

5.2.6 Output RF spectrum emissions

5.2.6.1 Occupied bandwidth

5.2.6.1.1 Description

Occupied bandwidth is a measure of the bandwidth containing 99% of the total integrated power for transmitted spectrum and is centered on the assigned channel frequency. The occupied channel bandwidth is about 1.6 MHz based on a chip rate of 1.28 Mcps.

5.2.6.1.2 Explanation of difference

In 3.84 Mcps TDD, the occupied channel bandwidth is less than 5MHz based on 3.84 Mcps.

But in 1.28 Mcps TDD, as the background analysis in WG4# 12 Meeting Tdoc515, which has been accepted to into the TR25.945, the occupied channel bandwidth should be less than 1.6 MHz based on 1.28 Mcps.

5.2.6.2 Out of band emission

Out of band emissions are unwanted emissions immediately outside the nominal channel resulting from the modulation process and non-linearity in the transmitter but excluding spurious emissions. This out of band emission limit is specified in terms of a spectrum emission mask and adjacent channel power ratio.

5.2.6.2.1 Spectrum emission mask

The spectrum emission mask of the UE applies to frequencies, which are between 0.8 and 4.0MHz from a carrier frequency. The out of channel emission is specified relative to the UE output power in measured in a 1.28 MHz bandwidth.

5.2.6.2.1.1 Minimum Requirement

The power of any UE emission shall not exceed the levels specified in Table 5.5.

Table 5.5: Spectrum Emission Mask Requirement (1.28 Mcps chip rate option)

| Frequency offset from carrier Δf | Minimum requirement | Measurement bandwidth |
|------------------------------------------|-----------------------------------|-----------------------|
| 0.8 MHz | -35 dBc | 30 kHz |
| 0.8-1.8 MHz | $-35 - 14 * (\Delta f - 0.8)$ dBc | 30 kHz |
| 1.8-2.4 MHz | $-49 - 17 * (\Delta f - 1.8)$ dBc | 30 kHz |
| 2.4 – 4.0MHz | -44 dBc | 1MHz |

NOTES: The first and last measurement position with a 30 kHz filter is 0.815 MHz and 2.385 MHz

The first and last measurement position with a 1 MHz filter is 2.9MHz and 3.5MHz

The lower limit shall be -55dBm/ 1.28 MHz or which ever is the higher.

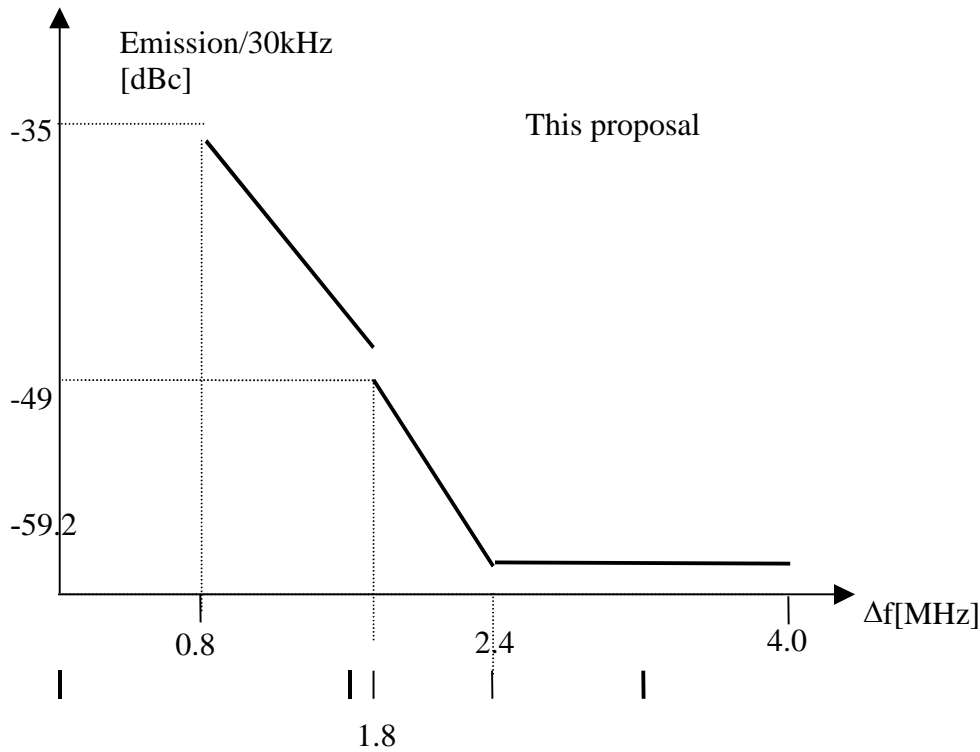

Fig 5.5 Proposed spectrum emission mask measured in 30kHz bandwidth

5.2.6.2.1.2 Rationale

Based on the discussion, the mask in Table 5.6 is proposed for power class 5 (21 dBm), given in dBc compared with 21dBm/1.28MHz. The rationale for each specification point is outlined in the table together with the proposed mask and the corresponding mask values, measured in 30 kHz (the smallest measurement bandwidth used):

Table 5.6: Proposed spectrum emission mask values and rationale.

| Frequency offset Δf | Minimum requirement (whichever is lower) | Measurement bandwidth | Comments for rationale | Corresponding value in 30 kHz |
|---------------------|------------------------------------------|-----------------------|-------------------------------------------------------------------------------------------------------|-------------------------------|
| 0,8 MHz | (-14 dBm) -35 dBc | 30 kHz | Based on FCC part 24: -13 dBm/14,6 kHz ; And 1,28 Mcps TDD emission specification ¹⁾ | -35 dBc |
| 0,8 - 1,8 MHz | $-35 - 14 * (\Delta f - 0.8)$ dBc | 30 kHz | Dropping linearly from 0,8 to 1 MHz ²⁾ | |
| 1,8 MHz | (-28 dBm) -49 dBc | 30 kHz | Based on FCC part 24: -13 dBm/1 MHz | -49 dBc |
| 1,8 - 2,4 MHz | $-49 - 17 * (\Delta f - 1.8)$ dBc | 30 kHz ³⁾ | Based on ACLR @1,6 MHz -33 dBc/1,28 MHz for 21 dBm UE ⁴⁾ | |
| 2,4 - 4,0 MHz | (-28 dBm) -44 dBc | 1 MHz | Based on ACLR @3,2 MHz -43 dBc/1,28 MHz for 21 dBm UE | -59.2 dBc |

5.2.6.2.1.2.1 Frequency offset

In FCC, frequency offset reference is the allocated band edge. Since spectrum definition has to be independent of operator allocation, the reference has been changed to the center frequency of the measured carrier. Assuming that the nominal carrier spacing is 1.6MHz for low chip rate TDD option, so spectrum mask definition starts at 0.8MHz offset.

5.2.6.2.1.2.2 Measurement bandwidth

The "-26dB modulation bandwidth" is approximately equal to 1.46MHz in low chip rate option. This leads to 14.6kHz-measurement bandwidth. Since this value is not available in most measurement devices such as spectrum analyzers, a standard value of 30kHz was adopted.

5.2.6.2.1.2.3 Mask shape

- 1) According to FCC rules, the emission should be $-13\text{dBm}/14.6\text{kHz}$ or $-10\text{dBm}/30\text{kHz}$. But in accordance with the 3.84 Mcps TDD emission only -14dBm is allowed to have no more 'dBm/Hz power' in the adjacent band as the 3.84 Mcps TDD has. (Because the physical origin of the modulation side band is the same in both cases the level of the leakage power should also be the same.)
- 2) The level of the slope from 0.8MHz to 1.8 MHz has been set in order to maintain a monotonic requirement around the 1.8MHz offset where the measurement bandwidth changes from 30kHz to 1MHz.
- 3) Based on FCC rules, after 1MHz offset (1.8MHz frequency point here) from the allocated frequency band edge, the measurement bandwidth should be 1MHz then, but considering that from 1.8MHz to 2.4MHz (2nd carrier band limit) only 0.6MHz, it is less than 1MHz. Thus we change back to 30kHz so that it could be reasonable to measurement.
- 4) Based on the ACLR@3.2MHz requirement, the emission value is tighter than that of the FCC rules, therefore the tighter value has been deployed in the table.

5.2.6.2.2 Adjacent Channel Leakage power Ratio (ACLR)

Adjacent Channel Leakage power Ratio (ACLR) is the ratio of the transmitted power to the power measured in an adjacent channels. Both the transmitted power and the adjacent channel power are measured with a filter response that has a Root-Raised Cosine (RRC) filter response with roll-off $\alpha = 0.22$ and a bandwidth equal to the chip rate.

If the adjacent power is greater than -55dBm then the ACLR shall be better than the values specified in the following Table.

Table 5.7: UE ACLR (1.28 Mcps chip rate)

| Power Class | UE channel | ACLR limit |
|-------------|----------------------|------------|
| 21dBm | $\pm 1.6\text{ MHz}$ | 33 dB |
| 21dBm | $\pm 3.2\text{ MHz}$ | 43 dB |

Notes: The requirement shall still be met in the presence of switching transients.

The ACLR requirements reflect what can be achieved with present state of the art technology.

Requirement on the UE shall be reconsidered when the state of the art technology progresses.

5.2.6.3 Spurious emissions

Spurious emissions are emissions which are caused by unwanted transmitter effects such as harmonics emission, parasitic emission, intermodulation products and frequency conversion products, but exclude out of band emissions.

The frequency boundary and the detailed transitions of the limits between the requirement for out band emissions and spectrum emissions are based on ITU-R Recommendations SM.329 [16].

5.2.6.3.1 Minimum Requirement

These requirements are only applicable for frequencies which are greater than 4 MHz away from the UE center carrier frequency.

Table 5.8 : General Spurious emissions requirements

| Frequency Bandwidth | Resolution Bandwidth | Minimum requirement |
|--------------------------------------------|----------------------|---------------------|
| $9 \text{ kHz} \leq f < 150 \text{ kHz}$ | 1 kHz | -36 dBm |
| $150 \text{ kHz} \leq f < 30 \text{ MHz}$ | 10 kHz | -36 dBm |
| $30 \text{ MHz} \leq f < 1000 \text{ MHz}$ | 100 kHz | -36 dBm |
| $1 \text{ GHz} \leq f < 12.75 \text{ GHz}$ | 1 MHz | -30 dBm |

Table 5.9: Additional Spurious emissions requirements

| Frequency Bandwidth | Resolution Bandwidth | Minimum requirement |
|-------------------------------------------------|----------------------|---------------------|
| $925 \text{ MHz} \leq f \leq 935 \text{ MHz}$ | 100 KHz | -67 dBm* |
| $935 \text{ MHz} < f \leq 960 \text{ MHz}$ | 100 KHz | -79 dBm* |
| $1805 \text{ MHz} \leq f \leq 1880 \text{ MHz}$ | 100 KHz | -71 dBm* |

NOTE *: The measurements are made on frequencies which are integer multiples of 200 kHz. As exceptions, up to five measurements with a level up to the applicable requirements defined in Table 5.10 are permitted for each UARFCN used in the measurement.

5.2.6.3.2 Explanation of difference

The UETX Spurious emissions requirements basically keep in line with UTRAN FDD and 3.84 Mcps TDD.

For the frequency offset, as ITU specification SM.329 [16], the frequency limit between out of band emissions and spurious emissions is defined as 250% of the necessary bandwidth. In 1.28 Mcps option the necessary bandwidth is 1.6MHz, so the frequency offset from carrier frequency is

$$250\% \times 1.6\text{MHz} = 4\text{MHz}$$

5.2.7 Transmit intermodulation

The transmit intermodulation performance is a measure of the capability of the transmitter to inhibit the generation of signals in its non linear elements caused by presence of the wanted signal and an interfering signal reaching the transmitter via the antenna.

5.2.7.1 Minimum requirements

User Equipment(s) transmitting in close vicinity of each other can produce intermodulation products, which can fall into the UE, or BS receive band as an unwanted interfering signal. The UE intermodulation attenuation is defined by the ratio of the output power of the wanted signal to the output power of the intermodulation product when an interfering CW signal is added at a level below the wanted signal. Both the wanted signal power and the intermodulation product power are measured with a filter response that is root-raised cosine (RRC) with roll-off $\alpha=0.22$ and with a bandwidth equal to the chip rate.

For the 1.28 Mcps chip rate option, the requirement of transmitting intermodulation for carrier spacing 1.6MHz is prescribed in the following table.

Table 5.10: Transmitting intermodulation attenuation.

| | | |
|-------------------------------------------------|---------|---------|
| Interference signal frequency offset | 1.6MHz | 3.2MHz |
| Interference signal level | -40dBc | |
| Minimum requirement of intermodulation products | -31 dBc | -41 dBc |

Note: This requirement is applicable to the 21 dBm power class of UE.

5.2.8 Transmit Modulation

5.2.8.1 Transmit pulse shape filter

The transmit pulse-shaping filter is a root-raised cosine (RRC) with roll-off $\alpha = 0.22$ in the frequency domain. The impulse response of the chip impulse filter $RC_0(t)$ is

$$RC_0(t) = \frac{\sin\left(\pi \frac{t}{T_c}(1-\alpha)\right) + 4\alpha \frac{t}{T_c} \cos\left(\pi \frac{t}{T_c}(1+\alpha)\right)}{\pi \frac{t}{T_c} \left(1 - \left(4\alpha \frac{t}{T_c}\right)^2\right)}$$

Where the roll-off factor $\alpha = 0.22$ and the chip duration:

$$T_C = \frac{1}{\text{chiprate}} = 0.78125 \mu\text{s}$$

5.2.8.2 Error Vector Magnitude

Common with 3.84 Mcps TDD option.

5.2.8.2.1 Minimum Requirement

Common with 3.84 Mcps TDD option.

5.2.8.3 Peak Code Domain Error

Common with 3.84 Mcps TDD option.

5.2.8.3.1 Minimum Requirement

Common with 3.84 Mcps TDD option.

5.2.8.3.1 Rationale

For 3.84 Mcps and FDD, the minimum requirements for the error vector magnitude and peak code domain error ensures that:

- the error vector magnitude does not degrade the performance
- the error vector magnitude leads only to low increase for the transmitted output power to remain the E_b/N_0

The theoretical investigations have shown that the error vector magnitude is related to the spreading factor. Because the same spreading factors are used for low chip rate TDD and for high chiprate TDD, the same minimum requirement applies.

5.3 Receiver characteristics

5.3.1 General

Common with 3.84 Mcps TDD option.

5.3.2 Diversity characteristics

Common with 3.84 Mcps TDD option.

5.3.3 Reference sensitivity level

The reference sensitivity is the minimum receiver input power measured at the antenna port at which the BIT Error Ratio BER does not exceed a specific value.

5.3.3.1 Minimum Requirements

The BER shall not exceed 0.001 for the parameters specified in Table 5.11.

Table 5.11: Test parameters for reference sensitivity

| Parameter | Level | Unit |
|----------------------------------|-------|--------------|
| $\frac{\Sigma DPCH_Ec}{I_{or}}$ | 0 | dB |
| \hat{I}_{or} | -108 | dBm/1.28 MHz |

5.3.3.2 Simulation results

The simulation is done to 12.2kb/s data in static propagation condition for UE of 1.28 Mcps TDD. The service-mapping is specified in ANNEX C, and the simulation assumption is specified in section 9.

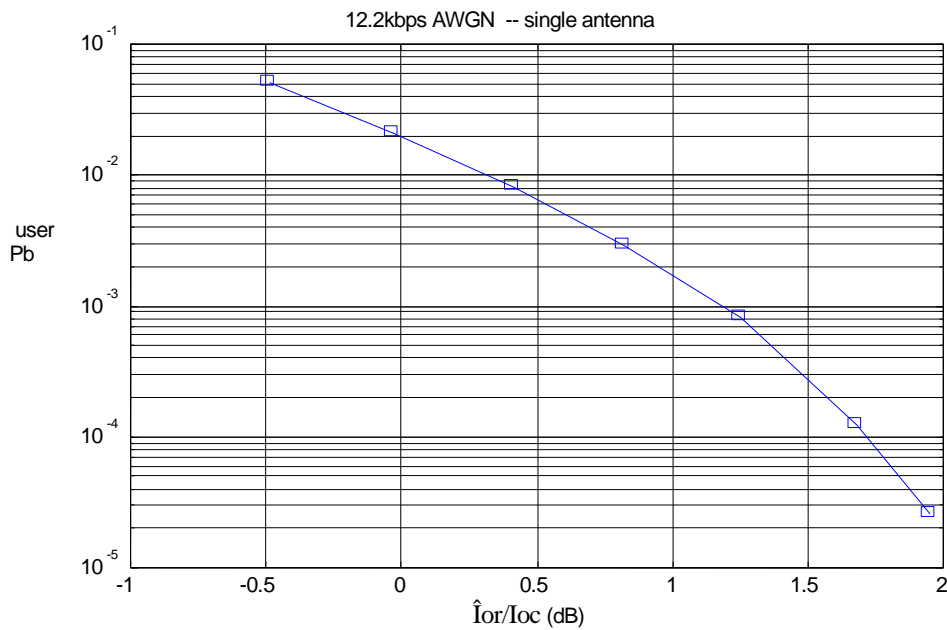

Figure 5.6

Table 5.12

| \hat{I}_{or}/I_{oc} | Pb |
|-----------------------|---------|
| -0.49 | 5.09E-2 |
| -0.03 | 2.12E-2 |
| 0.41 | 8.11E-3 |
| 0.82 | 2.90E-3 |
| 1.25 | 8.12E-4 |
| 1.68 | 1.23E-4 |
| 1.95 | 2.61E-5 |

5.3.3.3 Rationale

the simulations has been made with $\frac{\Sigma DPCH_Ec}{I_{or}} = -7\text{dB}$. That means that the reference sensitivity is $P_{\text{Noise}} + \text{Noise}$ -

Figure+ $\hat{I}_{or}/I_{oc_Limit} - \text{Own_Code_Power} + \text{Implementation_Margin} = -113\text{dBm} + 9\text{dB} + 1.2\text{dB} - 7\text{dB} + 2\text{dB} = -107.7\text{dBm}$. Roughly -108dBm which is the defined reference sensitivity level.

5.3.4 Maximum input level

This is defined as the maximum receiver input power at the UE antenna port which does not degrade the specified BER performance.

5.3.4.1 Minimum Requirements

The BER shall not exceed 0.001 for the parameters specified in Table 5.13

Table 5.13: Maximum input level

| Parameter | Level | Unit |
|----------------------------------|-------|--------------|
| $\frac{\Sigma DPCH_Ec}{I_{or}}$ | -7 | dB |
| \hat{I}_{or} | -25 | dBm/1.28 MHz |

5.3.5 Adjacent Channel Selectivity (ACS)

Adjacent Channel Selectivity is a measure of a receiver's ability to receive a wanted signal at its assigned channel frequency in the presence of adjacent channel signal at a given frequency offset from the centre frequency of the assigned channel. ACS is the ratio of the receive filter attenuation on the assigned channel frequency to the receiver filter attenuation on the adjacent channel(s).

5.3.5.1 Minimum Requirement

The ACS shall be better than the value indicated in Table 5.14 for the test parameters specified in Table 5.15 where the BER shall not exceed 0.001

Table 5.14: Adjacent Channel Selectivity

| Power Class | Unit | ACS |
|-------------|------|-----|
| 2 | dB | 33 |
| 3 | dB | 33 |

Table 5.15: Test parameters for Adjacent Channel Selectivity

| Parameter | Unit | Level |
|----------------------------------|--------------|--------------|
| $\frac{\Sigma DPCH_Ec}{I_{or}}$ | dB | 0 |
| \hat{I}_{or} | dBm/1.28MHz | -91 |
| I_{oac} | dBm/1.28 MHz | -54 |
| F_{offset} | MHz | +1.6 or -1.6 |

5.3.5.2 Rationale

The ACS performance of terminals is largely determined by an IF filter (usually a SAW), the A/D converter and digital baseband filtering. And the ACS requirements should reflect what can be achieved with present state of the art technology. So we can select the same receiver filter performance as 3.84 Mcps TDD, ACS equals to 33 dBc.

The wanted signal is set at -91dBm , just like that of 3.84 Mcps TDD, i.e., the wanted signal is 17dB above sensitivity level. Actually it has to be -94dBm to have the same distance to the reference sensitivity as the WTDD UE has. But the impact is negligible. In that case the signal is large enough compared to the noise. Which means in turn that the impact of the noise can be neglected and only the filter characteristic will be taken into consideration which is the intention with that test case.

Then the unwanted adjacent level could be derived as below:

$P_I \leq \text{sensitivity [dBm]} + 17\text{dB}$ (because the wanted signal is 17dB above the sensitivity) + ACS + 6dB (interference could be 6dB higher for the required BER as the wanted signal: see reference sensitivity) - 2dB (implementation margin) = -54dBm .

5.3.6 Blocking characteristics

The blocking characteristics is a measure of the receiver ability to receive a wanted signal at its assigned channel frequency in the presence of an unwanted interferer on frequencies other than those of the spurious response or the adjacent channels without this unwanted input signal causing a degradation of the performance of the receiver beyond a specified limit. The blocking performance shall apply at all frequencies except those at which a spurious response occur.

5.3.6.1 Minimum Requirement

The BER shall not exceed 0.001 for the parameters specified in table 5.16 and table 5.17. For table 5.17 up to 24 exceptions are allowed for spurious response frequencies in each assigned frequency channel when measured using a 1MHz step size.

Table 5.16: In-band blocking

| Parameter | Offset | Offset | Unit |
|-----------------------------------|------------------|------------------|--------------|
| Wanted Signal Level | <REFSENS> + 3 dB | <REFSENS> + 3 dB | dBm/1.28 MHz |
| Unwanted Signal Level (modulated) | -61 | -49 | dBm/1.28 MHz |
| F_{uw} (offset) | +3.2 or -3.2 | +4.8 or -4.8 | MHz |

Table 5.17: Out of band blocking

| Parameter | Band 1 | Band 2 | Band 3 | Unit |
|-----------------------------------------------------------------------------|---------------------------------------------------------|----------------------------------|--------------------------------|--------------|
| Wanted Signal Level | <REFSENS> + 3 dB | <REFSENS> + 3 dB | <REFSENS> + 3 dB | dBm/1.28 MHz |
| Unwanted Signal Level (CW) | -44 | -30 | -15 | dBm |
| F_{uw} For operation in frequency bands as defined in subclause 5.2(a) | 1840 <f <1895.2 1924.8 <f <2005.2 2029.8 <f <2085 | 1815 <f <1840 2085 <f <2110 | 1 <f <1815 2110 <f <12750 | MHz |
| F_{uw} For operation in frequency bands as defined in subclause 5.2(b) | 1790 <f < 1845.2 1994.8 <f < 2050 | 1765 <f < 1790 2050 <f < 2075 | 1 <f < 1765 2075 <f < 12750 | MHz |
| F_{uw} For operation in frequency bands as defined in subclause 5.2(c) | 1850 <f < 1905.2 1934.8 <f < 1990 | 1825 <f < 1850 1990 <f < 2015 | 1 <f < 1825 2015 <f < 12750 | MHz |

NOTE: For operation referenced in 5.1.2(a), from 1895.2 <f < 1900 MHz, 1920 <f < 1924.8 MHz, 2005.2 <f < 2010 MHz and 2025 <f < 2029.8 MHz, the appropriate in-band blocking or adjacent channel selectivity in section 5.3.5.1 shall be applied.

For operation referenced in 5.1.2(b), from $1845.2 < f < 1850$ MHz and $1990 < f < 1994.8$ MHz, the appropriate in-band blocking or adjacent channel selectivity in section 5.3.5.1 shall be applied.

For operation referenced in 5.1.2(c), from $1905.2 < f < 1910$ MHz and $1930 < f < 1934.8$ MHz, the appropriate in-band blocking or adjacent channel selectivity in section 5.3.5.1 shall be applied.

5.3.6.2 Rationale

5.3.6.2.1 3.2 MHz blocking requirement

From [17,18] the required interfering signal level can be calculated, just like FDD (which is of course true only if the wanted signal is 3dB above the reference level),

$$I_{\text{blocking}} = NF + 10 \cdot \log(1.28 \text{ Mcps}) - 174 \text{ dBm} / \text{Hz} + ACS2,$$

$$I_{\text{blocking}} = 9 \text{ dB} + 61 \text{ dB} - 174 \text{ dBm} / \text{Hz} + 43 \text{ dB} = -61 \text{ dBm}.$$

5.3.6.2.2 ACS, Adjacent channel selectivity and NF, Noise figure

In the equations above, the ACS2 is assumed as 43dB, and NF is assumed as 9dB. The principle is basically like FDD and 3.84 Mcps TDD, just the chiprate has been changed, so the in band blocking value is also scalable changed.

Considering the chiprate is 1.28 Mcps, so the unwanted signal frequency offset is also scalable changed from 3.84 Mcps TDD.

5.3.6.2.3 Out of band blocking requirement

The relevant frequency bands for out of band blocking are calculated according to the specified frequency bands for FDD in [19] and 3.84 Mcps TDD in [1]. The 3dB tougher requirement comparing to the WTDD/FDD is based on the assumption that the overall interference power is the same as in the other cases due to the same deployment scenarios. The NTDD UE has to withstand the same interference power as the WTDD/FD UE has to.

5.3.7 Spurious response

Spurious response is a measure of the receiver's ability to receive a wanted signal on its assigned channel frequency without exceeding a given degradation due to the presence of an unwanted CW interfering signal at any other frequency at which a response is obtained i.e. for which the blocking limit is not met.

5.3.7.1 Minimum Requirements

For the 1.28 Mcps chip rate option, the requirement of Spurious response for carrier spacing 1.6MHz is prescribed in the following table.

Table 5.18: Spurious Response (1.28MHz chiprate)

| Parameter | Level | Unit |
|----------------------------|-------------------------------|--------------|
| Wanted Signal Level | <REFSENS> + 3 dB | dBm/1.28 MHz |
| Unwanted Signal Level (CW) | -44 | dBm |
| F _{uw} | Spurious response frequencies | MHz |

5.3.7.2 Rationale

The 3dB tougher requirement comparing to the WTDD/FDD is based on the assumption that the overall interference power is the same as in the other cases due to the same deployment scenarios. The NTDD UE has to withstand the same interference power as the WTDD/FD UE has to.

5.3.8 Intermodulation characteristics

Third and higher order mixing of the two interfering RF signals can produce an interfering signal in the band of the desired channel. Intermodulation response rejection is a measure of the capability of the receiver to receive a wanted signal on its assigned channel frequency in the presence of two or more interfering signals which have a specific frequency relationship to the wanted signal.

5.3.8.1 Minimum Requirements

For the 1.28 Mcps chip rate option, the requirement of intermodulation for carrier spacing 1.6MHz is prescribed in the following table.

Table 5.19: Receive intermodulation characteristics (1.28MHz chiprate)

| Parameter | Level | Unit |
|-----------------------------------|------------------|--------------|
| $\frac{\Sigma DPCH - Ec}{I_{or}}$ | 0 | dB |
| \hat{I}_{or} | <REFSENS> + 3 dB | dBm/1.28 MHz |
| I_{ouw1} (CW) | -46 | dBm |
| I_{ouw2} (modulated) | -46 | dBm/1.28 MHz |
| F_{uw1} (CW) | 3.2 | MHz |
| F_{uw2} (Modulated) | 6.4 | MHz |

5.3.8.2 Rationale

The 3dB tougher requirement comparing to the WTDD/FDD is based on the assumption that the overall interference power is the same as in the other cases due to the same deployment scenarios. The NTDD UE has to withstand the same interference power as the WTDD/FD UE has to.

5.3.9 Spurious emissions

The Spurious Emissions Power is the power of emissions generated or amplified in a receiver that appear at the UE antenna connector.

5.3.9.1 Minimum Requirement

The power of any spurious emission shall not exceed:

Table 5.20: Receiver spurious emission requirements

| Band | Maximum level | Measurement Bandwidth | Note |
|----------------------------------------------------------------------------|---------------|-----------------------|--------------------------------------------------------------------------------------------------------------------------------------------|
| 9 kHz – 1 GHz | -57 dBm | 100 kHz | |
| 1 GHz – 1.9 GHz and 1.92 GHz – 2.01 GHz and 2.025 GHz – 2.11 GHz | -47 dBm | 1 MHz | With the exception of frequencies between 4MHz below the first carrier frequency and 4MHz above the last carrier frequency used by the UE. |
| 1.9 GHz – 1.92 GHz and 2.01 GHz – 2.025 GHz and 2.11 GHz – 2.170 GHz | -64 dBm | 1.28 MHz | With the exception of frequencies between 4MHz below the first carrier frequency and 4MHz above the last carrier frequency used by the UE. |
| 2.170 GHz – 12.75 GHz | -47 dBm | 1 MHz | |

5.3.9.2 Rationale

The inband (Band 3 in the above table) RX spurious emission value could be conducted as below.

Assumptions:

- The Noise Figure (NF) of the UE receiver is 9dB;
- The MCL for UE's is 40dB.

So the derivation is as follows:

$$\text{Spurious level} - \text{MCL (Minimum Coupling Loss)} < \text{Thermal noise}$$

$$\text{Spurious level} < \text{Thermal noise} + \text{MCL} = kT_0 + \text{NF} + \text{MCL} = -174\text{dBm/Hz} + 9\text{dB} + 40\text{dB} = -125\text{dBm/Hz}$$

In other way, in 1.28 Mcps TDD,

$$\text{Spurious level} < -64\text{dBm} / 1.28\text{MHz} (= -125\text{dBm/Hz})$$

The spurious levels in Band 1,2 and 4 are independent if the disturber is a FDD UE or a TDD UE. Therefore we propose to adopt these values for 1.28 Mcps TDD UE, just like 3.84 Mcps TDD UE.

The values of the 1.28 Mcps TDD UE receiver spurious levels from point 1 to 4 are proposed for approval for 1.28 Mcps TDD taking into account the impact of the TDD UE receiver spurious emission to the FDD UE receiver band.

For the frequency offset, as ITU specification, the frequency limit between out of band emissions and spurious emissions is defined as 250% of the necessary bandwidth. In 1.28 Mcps option the necessary bandwidth is 1.6MHz, so the frequency offset from carrier frequency is $250\% \times 1.6\text{MHz} = 4\text{MHz}$.

5.4 Performance requirement

5.4.1 General

The performance requirements for the UE in this section are specified for the measurement channels specified in Annex C and the propagation condition specified in Annex D.

Table 5.21: Summary of UE performance targets

| Test Chs. | Information Data Rate | Static | Multi-path Case 1 | Multi-path Case 2 | Multi-path Case 3 |
|-----------|-----------------------|---------------------------|---------------------------|---------------------------|------------------------------------|
| | | Performance metric | | | |
| DCH | 12.2 kbps | BLER < 10^{-2} | BLER < 10^{-2} | BLER < 10^{-2} | BLER < 10^{-2} |
| | 64 kbps | BLER < $10^{-1}, 10^{-2}$ | BLER < $10^{-1}, 10^{-2}$ | BLER < $10^{-1}, 10^{-2}$ | BLER < $10^{-1}, 10^{-2}, 10^{-3}$ |
| | 144 kbps | BLER < $10^{-1}, 10^{-2}$ | BLER < $10^{-1}, 10^{-2}$ | BLER < $10^{-1}, 10^{-2}$ | BLER < $10^{-1}, 10^{-2}, 10^{-3}$ |
| | 384 kbps | BLER < $10^{-1}, 10^{-2}$ | BLER < $10^{-1}, 10^{-2}$ | BLER < $10^{-1}, 10^{-2}$ | BLER < $10^{-1}, 10^{-2}, 10^{-3}$ |

5.4.2 Demodulation in static propagation conditions

5.4.2.1 Demodulation of DCH

The performance requirement of DCH in static propagation conditions is determined by the maximum Block Error Ratio (BLER). The BLER is specified for each individual data rate of the DCH. DCH is mapped into the Dedicated Physical Channel (DPCH).

5.4.2.1.1 Minimum requirement

For the parameters specified in Table 5.22 the BLER should not exceed the piece-wise linear BLER curve specified in Table 5.23.

Table 5.22: DCH parameters in static propagation conditions

| Parameters | Unit | Test 1 | Test 2 | Test 3 | Test 4 |
|-------------------------------|-------------|-------------------|--------|--------|--------|
| Number of DPCH _o | | 8 ¹⁾ | 2 | 2 | 0 |
| $\frac{DPCH_o - E_c}{I_{or}}$ | dB | -10 ¹⁾ | -10 | -10 | 0 |
| I_{oc} | dBm/1.28MHz | -60 | | | |
| Information Data Rate | Kbps | 12.2 | 64 | 144 | 384 |

5.4.2.1.2 Rationale

The simulation will be carried out with ten codes and each has the same power (-10dB/code). The number of interfering signals are 8. That means that the number of own codes are 2 or other way round the relation between the number of own codes divided by the whole number of codes is 2/10 or -7dB. That is the correction factor for the Test1. The other test cases above and throughout the following subclauses can be explained on the same way.

Table 5.23: Performance requirements in AWGN channel.

| Test Number | $\frac{\hat{I}_{or}}{I_{oc}}$ [dB] | BLER |
|-------------|------------------------------------|------------------|
| 1 | 3.1 | 10 ⁻² |
| 2 | 2.1 | 10 ⁻¹ |
| | 2.4 | 10 ⁻² |
| 3 | 2.5 | 10 ⁻¹ |
| | 2.8 | 10 ⁻² |
| 4 | 2.8 | 10 ⁻¹ |
| | 3.0 | 10 ⁻² |

5.4.3 Demodulation of DCH in multipath fading conditions

5.4.3.1 Multipath fading Case 1

The performance requirement of DCH is determined by the maximum Block Error Ratio (BLER). The BLER is specified for each individual data rate of the DCH. DCH is mapped into the Dedicated Physical Channel (DPCH).

5.4.3.1.1 Minimum requirement

For the parameters specified in Table 5.24 the BLER should not exceed the piece-wise linear BLER curve specified in Table 5.25.

Table 5.24: DCH parameters in multipath Case 1 channel

| Parameters | Unit | Test 1 | Test 2 | Test 3 | Test 4 |
|-------------------------------|-------------|--------|--------|--------|--------|
| Number of DPCH _o | | 8 | 2 | 2 | 0 |
| $\frac{DPCH_o - E_c}{I_{or}}$ | DB | -10 | -10 | -10 | 0 |
| I_{oc} | dBm/1.28MHz | -60 | | | |
| Information Data Rate | Kbps | 12.2 | 64 | 144 | 384 |

Table 5.25: Performance requirements in multipath Case 1 channel.

| Test Number | $\frac{\hat{I}_{or}}{I_{oc}}$ [dB] | BLER |
|-------------|------------------------------------|-----------|
| 1 | 22.2 | 10^{-2} |
| 2 | 15.0 | 10^{-1} |
| | 22.0 | 10^{-2} |
| 3 | 16.0 | 10^{-1} |
| | 23.0 | 10^{-2} |
| 4 | 16.0 | 10^{-1} |
| | 23.0 | 10^{-2} |

5.4.3.2 Multipath fading Case 2

The performance requirement of DCH is determined by the maximum Block Error Ratio (BLER). The BLER is specified for each individual data rate of the DCH. DCH is mapped into the Dedicated Physical Channel (DPCH).

5.4.3.2.1 Minimum requirement

For the parameters specified in Table 5.26 the BLER should not exceed the piece-wise linear BLER curve specified in Table 5.27.

Table 5.26: DCH parameters in multipath Case 2 channel

| Parameters | Unit | Test 1 | Test 2 | Test 3 | Test 4 |
|-------------------------------|-------------|--------|--------|--------|--------|
| Number of DPCH _o | | 8 | 2 | 2 | 0 |
| $\frac{DPCH_o - E_c}{I_{or}}$ | dB | -10 | -10 | -10 | 0 |
| I_{oc} | dBm/1.28MHz | -60 | | | |
| Information Data Rate | Kbps | 12.2 | 64 | 144 | 384 |

Table 5.27: Performance requirements in multipath Case 2 channel.

| Test Number | $\frac{\hat{I}_{or}}{I_{oc}}$ [dB] | BLER |
|-------------|------------------------------------|-----------|
| 1 | 13.2 | 10^{-2} |
| 2 | 9.5 | 10^{-1} |
| | 13.7 | 10^{-2} |
| 3 | 10.0 | 10^{-1} |
| | 14.0 | 10^{-2} |
| 4 | 10.0 | 10^{-1} |
| | 14.0 | 10^{-2} |

5.4.3.3 Multipath fading Case 3

The performance requirement of DCH is determined by the maximum Block Error Ratio (BLER). The BLER is specified for each individual data rate of the DCH. DCH is mapped into the Dedicated Physical Channel (DPCH).

5.4.3.3.1 Minimum requirement

For the parameters specified in Table 5.28 the BLER should not exceed the piece-wise linear BLER curve specified in Table 5.29.

Table 5.28: DCH parameters in multipath Case 3 channel

| Parameters | Unit | Test 1 | Test 2 | Test 3 | Test 4 |
|-------------------------------|-------------|--------|--------|--------|--------|
| Number of DPCH _o | | 8 | 2 | 2 | 0 |
| $\frac{DPCH_o - E_c}{I_{or}}$ | dB | -10 | -10 | -10 | 0 |
| I_{oc} | dBm/1.28MHz | -60 | | | |
| Information Data Rate | Kbps | 12.2 | 64 | 144 | 384 |

Table 5.29: Performance requirements in multipath Case 3 channel.

| Test Number | $\frac{\hat{I}_{or}}{I_{oc}}$ [dB] | BLER |
|-------------|------------------------------------|-----------|
| 1 | 10.8 | 10^{-2} |
| 2 | 8.3 | 10^{-1} |
| | 11.1 | 10^{-2} |
| | 13.8 | 10^{-3} |
| 3 | 8.7 | 10^{-1} |
| | 10.6 | 10^{-2} |
| | 11.8 | 10^{-3} |
| 4 | 8.8 | 10^{-1} |
| | 10.3 | 10^{-2} |
| | 11.5 | 10^{-3} |

5.4.3.4 Explanation difference

The different performance requirement is result from different propagation condition (Annex D), different service mapping (Annex C.2), different simulation assumption and different chip rate with 3.84 Mcps chip rate TDD.

The BCH test case, is testing the block STTD capability of the terminal. Block STTD is currently not supported by 1.28 Mcps chip rate TDD, as specified in TR 25.928. Therefore this test case is not needed for 1.28 Mcps chip rate TDD.

6 BS radio transmission and reception

6.1 Frequency bands and channel arrangement

6.1.1 General

The information presented in this section is based on a chip rate of 1.28 Mcps.

6.1.2 Frequency bands

Common with 3.84 Mcps TDD option.

6.1.3 TX–RX frequency separation

6.1.3.1 Description

No TX-RX frequency separation is required as Time Division Duplex (TDD) is employed. Each subframe of 1.28 Mcps TDD consists of 7 main timeslots (TS0 ~ TS6) where TS0 (before DL to UL switching point) are always allocated DL, the timeslots (at least the first one) before the switching point (vice versa) are allocated UL and the timeslots after the switching point (vice versa) are allocated DL.

6.1.3.2 Explanation of difference

The frame structure for 3.84 Mcps TDD and 1.28 Mcps TDD is different. For 3.84 Mcps TDD, each TDMA frame consists of 15 timeslots where each timeslot can be allocated to either transmit or receive.

6.1.4 Channel arrangement

6.1.4.1 Channel spacing

6.1.4.1.1 Background

The chip rate is 1.28 Mcps with a roll-off factor of 0.22, therefore the occupied bandwidth is 1.6MHz.

It is just nominal for 1.6MHz, and it is also flexible to adjust the channel raster step 200kHz to narrow as 1.4MHz for strict requirement situations if needed.

6.1.4.1.2 Channel spacing

The channel spacing for 1.28 Mcps chip rate option is 1.6MHz.

6.1.4.2 Channel raster

Common with 3.84 Mcps TDD option.

6.1.4.3 Channel number

Common with 3.84 Mcps TDD option.

6.2 Transmitter characteristics

6.2.1 General

Common with 3.84 Mcps TDD option.

6.2.2 Base station output power

Common with 3.84 Mcps TDD option.

6.2.2.1 Base station maximum output power

Common with 3.84 Mcps TDD option.

6.2.2.1.1 Minimum requirement

Common with 3.84 Mcps TDD option.

6.2.3 Frequency stability

Common with 3.84 Mcps TDD option.

6.2.4 Output power dynamics

Common with 3.84 Mcps TDD option.

6.2.4.1 Inner loop power control

Common with 3.84 Mcps TDD option.

6.2.4.2 Power control steps

Common with 3.84 Mcps TDD option.

6.2.4.2.1 Minimum requirement

Common with 3.84 Mcps TDD option.

6.2.4.3 Power control dynamic range

Common with 3.84 Mcps TDD option.

6.2.4.3.1 Minimum requirement

Common with 3.84 Mcps TDD option.

6.2.4.4 Minimum transmit power

Common with 3.84 Mcps TDD option.

6.2.4.4.1 Minimum requirement

Common with 3.84 Mcps TDD option.

6.2.4.5 Primary CCPCH power

Common with 3.84 Mcps TDD option.

6.2.5 Transmit ON/OFF power

6.2.5.1 Transmit OFF power

The transmit OFF power state is when the BS does not transmit. This parameter is defined as maximum output transmit power within the channel bandwidth when the transmitter is OFF.

6.2.5.1.1 Minimum Requirement

The requirement of transmit OFF power shall be better than -82 dBm measured with a filter that has a Root Raised Cosine (RRC) filter response with a roll off $\alpha=0.22$ and a bandwidth equal to the chip rate.

6.2.5.1.2 Rationale

Assuming the Noise Figure(NF) of BS is 7dB and Minimum Couple Loss(MCL) is 30dB. For the victim receiver, the Tx OFF power should not exceed the thermal noise. If Tx OFF power is 6dB below thermal noise, it will introduce 1dB degradation. The proposal for Tx OFF power is as follows:

$$P_N = -174 \text{ dBm/Hz} + 10\log(1.28 \text{ MHz/Hz}) + \text{NF}(7 \text{ dB}) = -106 \text{ dBm}$$

$$P_{Tx_OFF} \leq P_N - 6\text{dB} + \text{MCL} = -106 - 6 + 30 = -82\text{dBm}$$

NOTE: In 1.28 Mcps TDD option, The noise figure of BS is assumed to be 7dB, it is based on that this parameter has been approved by CWTS yet and it is easier for implementation of BS.

6.2.5.2 Transmit ON/OFF Time mask

The time mask transmit ON/OFF defines the ramping time allowed for the BS between transmit OFF power and transmit ON power.

6.2.5.2.1 Minimum Requirement

The transmit power level versus time should meet the mask specified in below figure.

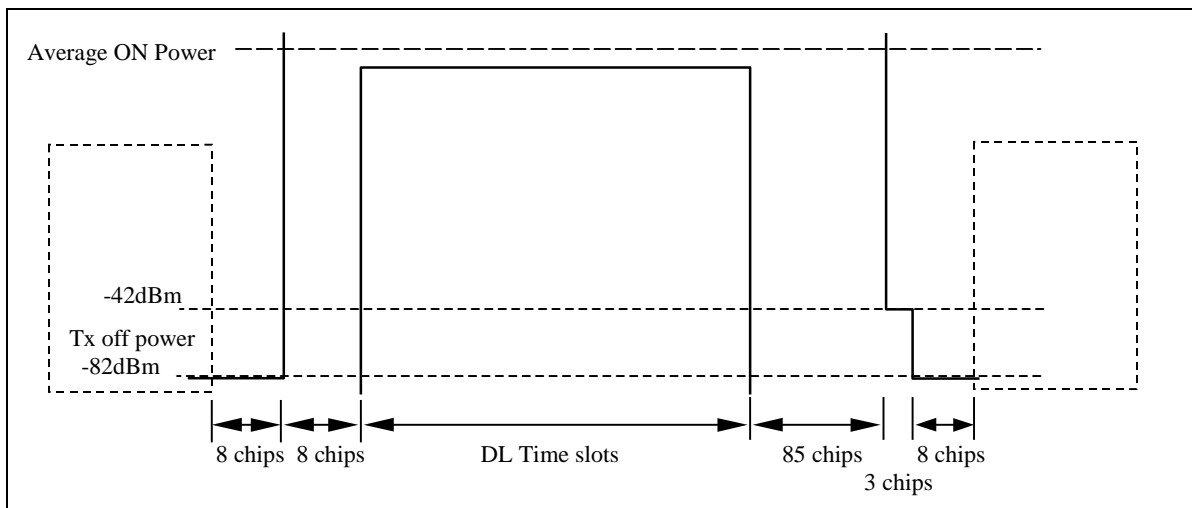

Figure 6.1

6.2.6 Output RF spectrum emissions

6.2.6.1 Occupied bandwidth

6.2.6.1.1 Description

Occupied bandwidth is a measure of the bandwidth containing 99% of the total integrated power for transmitted spectrum and is centered on the assigned channel frequency. The occupied channel bandwidth is about 1.6 MHz based on a chip rate of 1.28 Mcps.

6.2.6.1.2 Explanation of difference

In 3.84 Mcps TDD, the occupied channel bandwidth is less than 5MHz based on 3.84 Mcps.

But in 1.28 Mcps TDD, as the background analysis in WG4#12 Meeting Tdoc515, which has been accepted to into the TR25.945, the occupied channel bandwidth should be less than 1.6 MHz based on 1.28 Mcps.

6.2.6.2 Out of band emission

6.2.6.2.1 Spectrum emission mask

The mask defined in Tables 6.1 to 6.4 below may be mandatory in certain regions. In other regions this mask may not be applied.

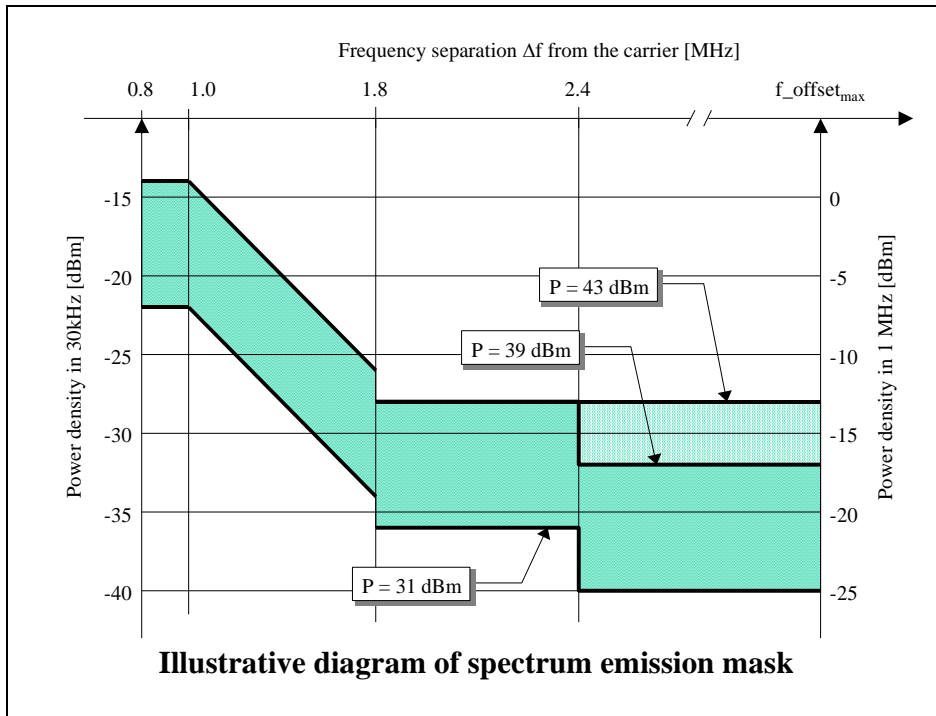

Figure 6.2

Table 6.1: Spectrum emission mask values, BS maximum output power $P \geq 43$ dBm

| Frequency offset of measurement filter – 3dB point, Δf | Frequency offset of measurement filter centre frequency, f_{offset} | Maximum level | Measurement bandwidth |
|----------------------------------------------------------------|------------------------------------------------------------------------------|--------------------------------------------------|-----------------------|
| $0.8 \leq \Delta f < 1.0$ MHz | $0.815\text{MHz} \leq f_{\text{offset}} < 1.015\text{MHz}$ | -14 dBm | 30 kHz |
| $1.0 \leq \Delta f < 1.8$ MHz | $1.015\text{MHz} \leq f_{\text{offset}} < 1.815\text{MHz}$ | $-14 - 15 \cdot (f_{\text{offset}} - 1.015)$ dBm | 30 kHz |
| See note | $1.815\text{MHz} \leq f_{\text{offset}} < 2.3\text{MHz}$ | -28 dBm | 30 kHz |
| $1.8 \leq \Delta f$ MHz | $2.3\text{MHz} \leq f_{\text{offset}} < f_{\text{offset}_{\text{max}}}$ | -13 dBm | 1 MHz |

Table 6.2: Spectrum emission mask values, BS maximum output power $39 \leq P < 43$ dBm

| Frequency offset of measurement filter – 3dB point, Δf | Frequency offset of measurement filter centre frequency, f_{offset} | Maximum level | Measurement bandwidth |
|----------------------------------------------------------------|------------------------------------------------------------------------------|--------------------------------------------------|-----------------------|
| $0.8 \leq \Delta f < 1.0$ MHz | $0.815\text{MHz} \leq f_{\text{offset}} < 1.015\text{MHz}$ | -14 dBm | 30 kHz |
| $1.0 \leq \Delta f < 1.8$ MHz | $1.015\text{MHz} \leq f_{\text{offset}} < 1.815\text{MHz}$ | $-14 - 15 \cdot (f_{\text{offset}} - 1.015)$ dBm | 30 kHz |
| $1.8 \leq \Delta f < 2.4$ MHz | $1.815\text{MHz} \leq f_{\text{offset}} < 2.415\text{MHz}$ | -28 dBm | 30 kHz |
| See note | $2.415\text{MHz} \leq f_{\text{offset}} < 2.9\text{MHz}$ | $P - 71$ dBm | 30 kHz |
| $2.4 \leq \Delta f$ MHz | $2.9\text{MHz} \leq f_{\text{offset}} < f_{\text{offset}_{\text{max}}}$ | $P - 56$ dBm | 1 MHz |

Table 6.3: Spectrum emission mask values, BS maximum output power $31 \leq P < 39$ dBm

| Frequency offset of measurement filter – 3dB point, Δf | Frequency offset of measurement filter centre frequency, f_{offset} | Maximum level | Measurement bandwidth |
|----------------------------------------------------------------|------------------------------------------------------------------------------|-----------------------------------------------------|-----------------------|
| $0.8 \leq \Delta f < 1.0$ MHz | $0.815\text{MHz} \leq f_{\text{offset}} < 1.015\text{MHz}$ | $P - 53$ dBm | 30 kHz |
| $1.0 \leq \Delta f < 1.8$ MHz | $1.015\text{MHz} \leq f_{\text{offset}} < 1.815\text{MHz}$ | $P - 53 - 15 \cdot (f_{\text{offset}} - 1.015)$ dBm | 30 kHz |
| $1.8 \leq \Delta f < 2.4$ MHz | $1.815\text{MHz} \leq f_{\text{offset}} < 2.415\text{MHz}$ | $P - 67$ dBm | 30 kHz |
| See note | $2.415\text{MHz} \leq f_{\text{offset}} < 2.9\text{MHz}$ | $P - 71$ dBm | 30 kHz |
| $2.4 \leq \Delta f$ MHz | $2.9\text{MHz} \leq f_{\text{offset}} < f_{\text{offset}_{\text{max}}}$ | $P - 56$ dBm | 1 MHz |

Table 6.4: Spectrum emission mask values, BS maximum output power $P < 31$ dBm

| Frequency offset of measurement filter – 3dB point, Δf | Frequency offset of measurement filter centre frequency, f_{offset} | Maximum level | Measurement bandwidth |
|----------------------------------------------------------------|------------------------------------------------------------------------------|--------------------------------------------------|-----------------------|
| $0.8 \leq \Delta f < 1.0$ MHz | $0.815\text{MHz} \leq f_{\text{offset}} < 1.015\text{MHz}$ | -22 dBm | 30 kHz |
| $1.0 \leq \Delta f < 1.8$ MHz | $1.015\text{MHz} \leq f_{\text{offset}} < 1.815\text{MHz}$ | $-22 - 15 \cdot (f_{\text{offset}} - 1.015)$ dBm | 30 kHz |
| $1.8 \leq \Delta f < 2.4$ MHz | $1.815\text{MHz} \leq f_{\text{offset}} < 2.415\text{MHz}$ | -36 dBm | 30 kHz |
| See note | $2.415\text{MHz} \leq f_{\text{offset}} < 2.9\text{MHz}$ | -40 dBm | 30 kHz |
| $2.4 \leq \Delta f$ MHz | $2.9\text{MHz} \leq f_{\text{offset}} < f_{\text{offset}_{\text{max}}}$ | -25 dBm | 1 MHz |

$f_{\text{offset}_{\text{max}}}$ is either 4.0 MHz or the offset to the UMTS Tx band edge as defined in section 6.1.2 of TR25.945 whichever is the greater.

NOTE: This frequency range ensures that the range of values of f_{offset} is continuous.

6.2.6.2.2 Explanation

6.2.6.2.2.1 Frequency offset

Because the nominal bandwidth of 1.28 Mcps TDD option, the spectrum mask definition starts at 0.8MHz offset.

6.2.6.2.2.2 Measurement bandwidth

“-26dB modulation bandwidth” of 1.28 Mcps TDD option is smaller than that of 3.84 Mcps TDD option, so a higher emission is allowed. However, in accordance with the 3.84 Mcps TDD option, the same level and measurement bandwidth are used.

6.2.6.2.2.3 Mask shape

For the flat region from 0.8MHz to 1.0MHz, it gives sufficient margin to cope with the unwanted spectral response due to baseband modulation, and allows to provide additional protection for the second narrow-band channel in case of narrow-band services (using 200kHz channel raster). In addition, the slope from 1.0MHz to 1.8MHz is for reflecting more accurately PA behaviour and providing further guarantee on levels in adjacent bandwidth.

6.2.6.2A Adjacent Channel Leakage power Ratio(ACLR)

6.2.6.2A.1 Minimum requirement

For the 1.28 Mcps chip rate option, the ACLR shall be better than the value specified in the following Table.

Table 6.5: BS ACLR (1.28 Mcps chip rate)

| BS adjacent channel offset | ACLR limit |
|----------------------------|------------|
| ± 1.6 MHz | 40 dB |
| ± 3.2 MHz | 50 dB |

NOTE: This requirement is valid for co-existence with frame and switching point synchronized systems, or for non-synchronized systems if the path loss between the BSs is greater than 107dB.

6.2.6.2A.2 Requirement in case of operation in proximity to TDD BS or FDD BS operating on an adjacent frequency

In case the equipment is operated in proximity to another TDD BS or FDD BS and both BSs operating on an adjacent frequency band, the requirement is specified in terms of power level of the transmitting BS. This requirement is valid for co-existence with non-frame and non-switching point synchronised systems operating on the closest used carrier. The interference power level shall not exceed the limit in Table 6.6.

Table 6.6: BS ACLR in case of operation in proximity

| Center Frequency for Measurement | Maximum Level of the interference power (in case of multiple antennas the interference powers shall be summed at all antenna connectors) | Measurement Bandwidth |
|----------------------------------------------------------------------------------------------------------------------------|------------------------------------------------------------------------------------------------------------------------------------------|-------------------------------------------------------------------------------------------------------------------------------------------|
| Closest used carrier of the victim receiver: Either FDD carrier Or 3.84 Mcps TDD carrier Or 1.28 Mcps TDD carrier | -36 dBm | chip rate of the victim receiver: In case of FDD: 3.84 MHz In case of 3.84 Mcps TDD: 3.84 MHz In case of 1.28 Mcps TDD: 1.28 MHz |

The closest used carrier with respect to the regarded carrier of one system is defined by:

A minimum difference in centre frequency between the regarded carrier and the carriers used in the other system and the chip rate of the other system.

If the actual allowed interference level $P_{\text{int, allowed, actual}}$ at the victim receiver is higher than -106dBm , this requirement may be relaxed by the amount $P_{\text{int, allowed, actual}} - (-106\text{dBm})$.

6.2.6.2A.3 Requirement in case of co-siting with TDD BS or FDD BS operating on an adjacent frequency

In case the equipment is co-sited to another TDD BS or FDD BS and both BSs operating on an adjacent frequency band, the requirement is specified in terms of power level of the transmitting BS. This requirement is valid for co-existence with a non-frame and non-switching point synchronised systems operating on closest used carrier. The interference power level shall not exceed the limit in Table 6.7.

Table 6.7: BS ACLR in case of co-siting

| Center Frequency for Measurement | Maximum Level of the interference power (in case of multiple antennas the interference powers shall be summed at all antenna connectors) | Measurement Bandwidth |
|----------------------------------------------------------------------------------------------------------------------------|------------------------------------------------------------------------------------------------------------------------------------------|---------------------------------------------------------------------------------------------------------------------------------------|
| Closest used carrier of the victim receiver: Either FDD carrier Or 3.84 Mcps TDD carrier Or 1.28 Mcps TDD carrier | -76 dBm | Chip rate of victim receiver: In case of FDD: 3.84 MHz In case of 3.84 Mcps TDD: 3.84 MHz In case of 1.28 Mcps TDD: 1.28 MHz |

The closest used carrier with respect to the regarded carrier of one system is defined by:

A minimum difference in centre frequency between the regarded carrier and the carriers used in the other system and the chip rate of the other system.

If the actual MCL_{actual} is higher than 30dB, this requirement may be relaxed by the amount $MCL_{actual} - 30dB$.

If the actual allowed interference level $P_{int, allowed, actual}$ at the victim receiver is higher than $-106dBm$, this requirement may be relaxed by the amount $P_{int, allowed, actual} - (-106dBm)$.

6.2.6.3 Spurious emissions

Common with 3.84 Mcps option.

6.2.6.3.1 Mandatory Requirements

The requirements of either subclause 6.2.6.3.1.1 or subclause 6.2.6.3.1.2 shall apply whatever the type of transmitter considered (single carrier or multi-carrier). It applies for all transmission modes foreseen by the manufacturer's.

Either requirement applies at frequencies within the specified frequency ranges which are more than 4MHz under the first carrier frequency used or more than 4 MHz above the last carrier frequency used.

6.2.6.3.1.0 Explanation of difference

In 3.84 Mcps option, the frequency offset from carrier frequency is greater than 12.5MHz, while in 1.28 Mcps option it is greater than 4 MHz.

In ITU specification, the frequency limit between out of band emissions and spurious emissions is defined as 250% of the necessary bandwidth. In 1.28 Mcps option the necessary bandwidth is 1.6MHz, so the frequency offset from carrier frequency is:

$$250\% \times 1.6MHz = 4MHz$$

6.2.6.3.1.1 Spurious emissions (Category A)

Common with 3.84 Mcps option.

6.2.6.3.1.2 Spurious emissions (Category B)

The following requirements shall be met in cases where Category B limits for spurious emissions, as defined in ITU-R Recommendation SM.329 [16], are applied.

6.2.6.3.1.2.1 Minimum Requirement

The power of any spurious emission shall not exceed:

Table 6.8 BS Mandatory spurious emissions limits, Category B

| Band | Maximum Level | Measurement Bandwidth | Note |
|----------------------------------------------------------------------------------------------------------------------------------------|---------------|-----------------------|--------|
| 9kHz – 150kHz | - 36 dBm | 1 kHz | Note 1 |
| 150kHz – 30MHz | - 36 dBm | 10 kHz | Note 1 |
| 30MHz – 1GHz | - 36 dBm | 100 kHz | Note 1 |
| 1GHz ↔ Fc1 – 19.2 MHz or Fl - 3.2 MHz <i>whichever is the higher</i> | - 30 dBm | 1 MHz | Note 1 |
| Fc1 - 19.2 MHz or Fl - 3.2MHz <i>whichever is the higher</i> ↔ Fc1 - 16 MHz or Fl - 3.2 MHz <i>whichever is the higher</i> | - 25 dBm | 1 MHz | Note 2 |
| Fc1 - 16 MHz or Fl - 3.2 MHz <i>whichever is the higher</i> ↔ Fc2 + 16 MHz or Fu + 3.2 MHz <i>whichever is the lower</i> | - 15 dBm | 1 MHz | Note 2 |
| Fc2 + 16 MHz or Fu + 3.2 MHz <i>whichever is the lower</i> ↔ Fc2 + 19.2MHz or Fu + 3.2MHz <i>whichever is the lower</i> | - 25 dBm | 1 MHz | Note 2 |
| Fc2 + 19.2 MHz or Fu + 3.2 MHz <i>whichever is the lower</i> ↔ 12,5 GHz | - 30 dBm | 1 MHz | Note 3 |
| NOTE 1: Bandwidth as in ITU-R SM.329 [16], s4.1 | | | |
| NOTE 2: Specification in accordance with ITU-R SM.329 [16], s4.3 and Annex 7 | | | |
| NOTE 3: Bandwidth as in ITU-R SM.329 [16], s4.3 and Annex 7. Upper frequency as in ITU-R SM.329 [1], s2.5 table 1 | | | |

Fc1: Center frequency of emission of the first carrier transmitted by the BS

Fc2: Center frequency of emission of the last carrier transmitted by the BS

Fl: Lower frequency of the band in which TDD operates

Fu: Upper frequency of the band in which TDD operates

6.2.6.3.2 Co-existence with GSM 900

Common with 3.84 Mcps TDD option.

6.2.6.3.2.1 Operation in the same geographic area

Common with 3.84 Mcps TDD option.

6.2.6.3.2.1.1 Minimum requirement

Common with 3.84 Mcps TDD option.

6.2.6.3.2.2 Co-located base stations

Common with 3.84 Mcps TDD option.

6.2.6.3.2.2.1 Minimum requirement

Common with 3.84 Mcps TDD option.

6.2.6.3.3 Co-existence with DCS 1800

Common with 3.84 Mcps TDD option.

6.2.6.3.3.1 Operation in the same geographic area

Common with 3.84 Mcps TDD option.

6.2.6.3.3.1.1 Minimum requirement

Common with 3.84 Mcps TDD option.

6.2.6.3.3.2 Co-located base stations

Common with 3.84 Mcps TDD option.

6.2.6.3.3.2.1 Minimum requirement

Common with 3.84 Mcps TDD option.

6.2.6.3.4 Co-existence with UTRA FDD

Common with 3.84 Mcps TDD option.

6.2.6.3.4.1 Operation in the same geographic area

Common with 3.84 Mcps TDD option.

6.2.6.3.4.1.1 Minimum requirement

Common with 3.84 Mcps TDD option.

6.2.6.3.4.2 Co-located base stations

Common with 3.84 Mcps TDD option.

6.2.6.3.4.2.1 Minimum requirement

Common with 3.84 Mcps TDD option.

6.2.7 Transmit intermodulation

The transmit intermodulation performance is a measure of the capability of the transmitter to inhibit the generation of signals in its non linear elements caused by presence of the wanted signal and an interfering signal reaching the transmitter via the antenna.

The transmit intermodulation level is the power of the intermodulation products when a CDMA modulated interference signal is injected into the antenna connector at a level of 30 dB lower than that of the subject signal. The frequency of the interference signal shall be ± 1.6 MHz, ± 3.2 MHz and ± 4.8 MHz offset from the subject signal.

6.2.7.0 Explanation of difference

In 1.28 Mcps option, the necessary bandwidth is 1.6MHz. The frequency of interference signal is $1*NB, 2*NB$ and $3*NB$ offset from the subject, that means ± 1.6 MHz, ± 3.2 MHz and ± 4.8 MHz.

In 3.84 Mcps option, the necessary bandwidth is 5 MHz. So the frequency of interference signal is ± 5 MHz, ± 10 MHz and ± 15 MHz offset from subject signal.

6.2.7.1 Minimum requirement

The Transmit intermodulation level shall not exceed the out of band or the spurious emission requirements of section 6.2.6.2 and 6.2.6.3 in TR25.945.

6.2.8 Transmit modulation

6.2.8.1 Transmit pulse shape filter

The transmit pulse-shaping filter is a root-raised cosine (RRC) with roll-off $\alpha = 0.22$ in the frequency domain. The impulse response of the chip impulse filter $RC_0(t)$ is

$$RC_0(t) = \frac{\sin\left(\pi \frac{t}{T_c}(1-\alpha)\right) + 4\alpha \frac{t}{T_c} \cos\left(\pi \frac{t}{T_c}(1+\alpha)\right)}{\pi \frac{t}{T_c} \left(1 - \left(4\alpha \frac{t}{T_c}\right)^2\right)}$$

Where the roll-off factor $\alpha = 0.22$ and the chip duration:

$$T_C = \frac{1}{\text{chiprate}} = 0.78125\mu\text{s}$$

6.2.8.1.1 Explanation of difference

The chip rate for 1.28 Mcps TDD option is 1.28 Mcps, the chip duration is

$$T_C = \frac{1}{\text{chiprate}} = 0.78125\mu\text{s}.$$

While in 3.84 Mcps TDD option, the chip rate is 3.84 Mcps, the duration is

$$T_C = \frac{1}{\text{chiprate}} \approx 0.26042\mu\text{s}.$$

6.2.8.2 Modulation Accuracy

Common with 3.84 Mcps TDD option.

6.2.8.2.1 Minimum Requirement

Common with 3.84 Mcps TDD option.

6.2.8.3 Peak Code Domain Error

Common with 3.84 Mcps TDD option.

6.2.8.3.1 Minimum Requirement

Common with 3.84 Mcps TDD option.

6.2.8.3.2 Rationale

For 3.84 Mcps TDD and FDD, the minimum requirements for the error vector magnitude and peak code domain error ensures that

- the error vector magnitude does not degrade the performance
- the error vector magnitude leads only to low increase for the transmitted output power to remain the Eb/N0

The theoretical investigations have shown that the error vector magnitude is related to the spreading factor. Because the same spreading factors are used for 1.28 Mcps TDD and for 3.84 Mcps TDD, the same minimum requirement applies.

6.3 Receiver characteristics

6.3.1 General

Common with 3.84 Mcps TDD option.

6.3.2 Reference sensitivity level

The reference sensitivity is the minimum receiver input power measured at the antenna connector at which the FER/BER does not exceed the specific value indicated in section 6.3.2.1.

6.3.2.1 Minimum Requirement

For the measurement channel specified in the Annex C, the reference sensitivity level and performance of the BS shall be as specified in table 6.9 below.

Table 6.9: BS reference sensitivity levels

| Data rate | BS reference sensitivity level (dBm) | FER/BER |
|-----------|--------------------------------------|----------------------------|
| 12.2 kbps | -110 dBm | BER shall not exceed 0.001 |

6.3.2.2 Rationale

The reference sensitivity value of BS for 1.28 Mcps TDD is derived from the following formula. Assuming the noise figure(NF) of BS is 7dB, the noise floor is:

$$P_N = -174 \text{ dBm/Hz} + 10\log(1.28 \text{ MHz/Hz}) + \text{NF}(7 \text{ dB}) = -106 \text{ dBm}$$

According to the simulation results for 12.2Kbps measurement channel, the BER=0.001 is achieved at $\hat{I}_{or}/I_{oc} = 1.2\text{dB}$ with an own code power of 1/5 of the whole transmit code power (-7dB). In simulation, assume \hat{I}_{or} equal to I_{or} , we can get:

$$\frac{DPCH - E_c}{I_{oc}} = \frac{DPCH - E_c}{I_{or}} \frac{\hat{I}_{or}}{I_{oc}} = -7 \text{ dB} + 1.2\text{dB} = -5.8 \text{ dB}$$

The sensitivity value without implementation is calculated as follows:

$$P_s = \frac{DPCH - E_c}{I_{oc}} P_N = -106 \text{ dBm} - 5.8\text{dB} = -111.8\text{dBm}$$

If the implementation margin is considered to be 1.5dB, the final sensitivity value is:

$$P_s = -111.8 \text{ dBm} + \text{margin} = -110.3 \text{ dBm}$$

The reference sensitivity value of -110dBm is proposed to the BS specification for 1.28 Mcps TDD .

NOTE: In 1.28 Mcps TDD option, The noise figure of BS is assumed to be 7dB, it is based on that this parameter has been approved by CWTS yet and it is easier for implementation of BS.

6.3.2.3 Simulation results

The simulation is done to 12.2kb/s data in static propagation condition for BS of 1.28 Mcps TDD. The service-mapping is specified in Annex C, and the simulation assumption is specified in section 9.

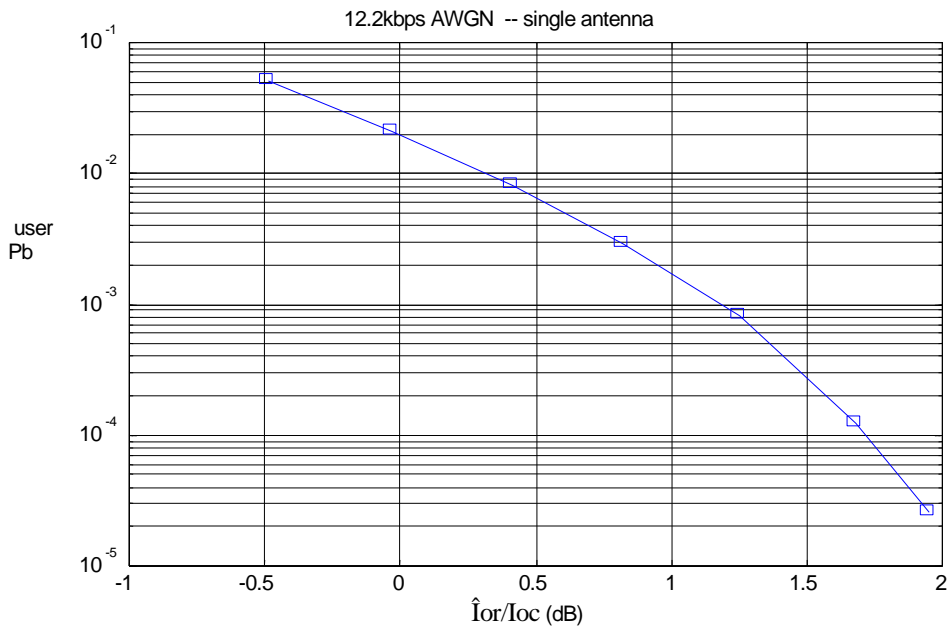

Figure 6.3

Table 6.10

| Ior/Ioc | Pb |
|---------|---------|
| -0.49 | 5.09E-2 |
| -0.03 | 2.12E-2 |
| 0.41 | 8.11E-3 |
| 0.82 | 2.90E-3 |
| 1.25 | 8.12E-4 |
| 1.68 | 1.23E-4 |
| 1.95 | 2.61E-5 |

6.3.2.4 Maximum Frequency Deviation for Receiver Performance

The need for such a requirement is for further study.

6.3.3 Dynamic range

Receiver dynamic range is the receiver ability to handle a rise of interference in the reception frequency channel. The receiver shall fulfil a specified BER requirement for a specified sensitivity degradation of the wanted signal in the presence of an interfering AWGN signal in the same reception frequency channel.

6.3.3.1 Minimum requirement

The BER shall not exceed 0.001 for the parameters specified in Table 6.11.

Table 6.11: Dynamic Range

| Parameter | Level | Unit |
|-------------------------|-------------------|--------------|
| Data rate | 12.2 | kbps |
| Wanted signal | <REFSENS> + 30 dB | dBm |
| Interfering AWGN signal | -76dBm | dBm/1.28 MHz |

6.3.3.2 Rationale

When wanted signal level is 30 dB above the reference sensitivity level, in order to keep the performance of $BER \leq 0.001$ the maximum interfering signal P_I needs meet the following requirement:

$$\begin{aligned}
 P_I &\leq \text{noise floor [dBm]} + \text{noise figure [dB]} + 30 \text{ dB} \\
 &= -113 \text{ dBm} + 7 \text{ dB} + 30 \text{ dB} \\
 &= -76 \text{ dBm}
 \end{aligned}$$

It is also proposed to the BS conformance test, the section 8.4.3 this report.

NOTE: In 1.28 Mcps TDD option, The noise figure of BS is assumed to be 7dB, it is based on that this parameter has been approved by CWTS yet and it is easier for implementation of BS.

6.3.4 Adjacent Channel Selectivity (ACS)

Adjacent channel selectivity (ACS) is a measure of the receiver ability to receive a wanted signal at its assigned channel frequency in the presence of an adjacent channel signal at a given frequency offset from the center frequency of the assigned channel. ACS is the ratio of the receiver filter attenuation on the assigned channel frequency to the receive filter attenuation on the adjacent channel(s).

6.3.4.1 Minimum Requirement

The BER shall not exceed 0.001 for the parameters specified in table 6.12.

Table 6.12: Adjacent channel selectivity

| Parameter | Level | Unit |
|----------------------------|-----------------------------------|------|
| Data rate | 12.2 | kbps |
| Wanted signal | Reference sensitivity level + 6dB | dBm |
| Interfering signal | -55 | dBm |
| F _w (Modulated) | 1.6 | MHz |

6.3.4.2 Rationale

Assuming the receiver filter ACS equals to 45 dBc, in order to keep the performance of BER, the interference signal level P_I should meet the following requirement:

$$\begin{aligned}
 P_I &\leq \text{noise floor [dBm]} + \text{noise figure [dB]} + 6 \text{ dB (because the wanted signal is 6 dB above sensitivity)} + \text{ACS} \\
 &= -113 \text{ dBm} + 7 \text{ dB} + 6 \text{ dB} + 45 \text{ dBc} \\
 &= -55 \text{ dBm}
 \end{aligned}$$

NOTE: In 1.28 Mcps TDD option, The noise figure of BS is assumed to be 7dB, it is based on that this parameter has been approved by CWTS yet and it is easier for implementation of BS.

6.3.5 Blocking characteristics

The blocking characteristics is a measure of the receiver ability to receive a wanted signal at its assigned channel frequency in the presence of an unwanted interferer on frequencies other than those of the adjacent channels. The blocking performance shall apply at all frequencies as specified in the tables below, using a 1MHz step size.

6.3.5.1 Minimum Requirements

For the 1.28 Mcps chip rate option, the requirement of Blocking for carrier spacing 1.6MHz is prescribed in the following tables.

Table 6.13: Blocking requirements for operating bands defined in 6.1.2(a)

| Center Frequency of Interfering Signal | Interfering Signal Level | Wanted Signal Level | Minimum Offset of Interfering Signal | Type of Interfering Signal |
|---------------------------------------------------------|--------------------------|---------------------|--------------------------------------|---------------------------------------|
| 1900 – 1920 MHz, 2010 – 2025 MHz | -40 dBm | <REFSENS> + 6 dB | 3.2MHz | Narrow band CDMA signal with one code |
| 1880 – 1900 MHz, 1990 – 2010 MHz, 2025 – 2045 MHz | -40 dBm | <REFSENS> + 6 dB | 3.2MHz | Narrow band CDMA signal with one code |
| 1920 – 1980 MHz | -40 dBm | <REFSENS> + 6 dB | 3.2MHz | Narrow band CDMA signal with one code |
| 1 – 1880 MHz, 1980 – 1990 MHz, 2045 – 12750 MHz | -15 dBm | <REFSENS> + 6 dB | — | CW carrier |

Table6.14: Blocking requirements for operating bands defined in 6.1.2(b)

| Center Frequency of Interfering Signal | Interfering Signal Level | Wanted Signal Level | Minimum Offset of Interfering Signal | Type of Interfering Signal |
|----------------------------------------|--------------------------|---------------------|--------------------------------------|---------------------------------------|
| 1850 – 1990 MHz | -40 dBm | <REFSENS> + 6 dB | 3.2MHz | Narrow band CDMA signal with one code |
| 1830 – 1850 MHz, 1990 – 2010 MHz | -40 dBm | <REFSENS> + 6 dB | 3.2MHz | Narrow band CDMA signal with one code |
| 1 – 1830 MHz, 2010 – 12750 MHz | -15 dBm | <REFSENS> + 6 dB | — | CW carrier |

Table 6.15: Blocking requirements for operating bands defined in 6.1.2(c)

| Center Frequency of Interfering Signal | Interfering Signal Level | Wanted Signal Level | Minimum Offset of Interfering Signal | Type of Interfering Signal |
|----------------------------------------|--------------------------|---------------------|--------------------------------------|---------------------------------------|
| 1910 – 1930 MHz | -40 dBm | <REFSENS> + 6 dB | 3.2MHz | Narrow band CDMA signal with one code |
| 1890 – 1910 MHz, 1930 – 1950 MHz | -40 dBm | <REFSENS> + 6 dB | 3.2MHz | Narrow band CDMA signal with one code |
| 1 – 1890 MHz, 1950 – 12750 MHz | -15 dBm | <REFSENS> + 6 dB | — | CW carrier |

6.3.6 Intermodulation characteristics

Third and higher order mixing of the two interfering RF signals can produce an interfering signal in the band of the desired channel. Intermodulation response rejection is a measure of the capability of the receiver to receiver a wanted signal on its assigned channel frequency in the presence of two or more interfering signals which have a specific frequency relationship to the wanted signal.

The static reference performance as specified in clause 6.3.2.1 should be met when the following signals are coupled to BS antenna input.

A wanted signal at the assigned channel frequency, 6 dB above the static reference level.

Two interfering signals with the following parameters.

Table 6.16: Intermodulation requirement (1.28 Mcps chiprate)

| Interfering Signal Level | Offset | Type of Interfering Signal |
|--------------------------|---------|---------------------------------------|
| - 48 dBm | 3.2 MHz | CW signal |
| - 48 dBm | 6.4 MHz | Narrow band CDMA signal with one code |

6.3.6.1 Rationale

Intermodulation characteristics mean the BS receiver needs to have a sufficient capability to reject the interfering signals. Same frequency bands is applied for 1.28 Mcps and 3.84 Mcps TDD, therefore 1.28 Mcps TDD should be resistant to the same level of interfering signals at other frequencies. The level -48dBm is proposed for interfering signals without brackets.

6.3.7 Spurious emissions

The spurious emissions power is the power of emissions generated or amplified in a receiver that appear at the BS antenna connector. The requirements apply to all BS with separate RX and TX antenna port. The test shall be performed when both TX and RX are on with the TX port terminated.

For all BS with common RX and TX antenna port the transmitter spurious emission as specified in section 6.2.6.3 is valid.

6.3.7.1 Minimum Requirement

The power of any spurious emission shall not exceed:

Table 6.17: Receiver spurious emission requirements

| Band | Maximum level | Measurement Bandwidth | Note |
|---------------------------------------------|---------------|-----------------------|--------------------------------------------------------------------------------------------------------------------------------------------|
| 9 kHz – 1 GHz | -57 dBm | 100 kHz | |
| 1 GHz – 1.9 GHz and 1.98 GHz – 2.01 GHz | -47 dBm | 1 MHz | With the exception of frequencies between 4MHz below the first carrier frequency and 4MHz above the last carrier frequency used by the BS. |
| 1.9 GHz – 1.98 GHz and 2.01 GHz – 2.025 GHz | -83 dBm | 1.28 MHz | With the exception of frequencies between 4MHz below the first carrier frequency and 4MHz above the last carrier frequency used by the BS. |
| 2.025 GHz – 12.75 GHz | -47 dBm | 1 MHz | With the exception of frequencies between 4MHz below the first carrier frequency and 4MHz above the last carrier frequency used by the BS. |

6.3.7.2 Rationale

Assuming the Minimum Couple Loss (MCL) is 30dB. For the victim receiver, the spurious emissions power generated by the BS receiver should not exceed the thermal noise. . The proposal for spurious emission power that located in the 1.9 GHz – 1.98 GHz and 2.01 GHz – 2.025 GHz band is as follows:

$$P_N = -174 \text{ dBm/Hz} + 10\log(1.28 \text{ MHz/Hz}) = -113 \text{ dBm}$$

$$P_{Spurious} \leq P_N + MCL = -113 + 30 = -83dBm$$

This leads to the same requirement as for 3.84 Mcps TDD. The different value is only due to the 1.28 MHz measurement bandwidth.

6.4 Performance requirement

6.4.1 General

Performance requirements for the BS are specified for the measurement channels defined in Annex C and the propagation conditions in Annex D. The requirements only apply to those measurement channels that are supported by the base station.

The requirements only apply to a base station with dual receiver antenna diversity. The required \hat{I}_{or}/I_{oc} shall be applied separately at each antenna port.

Table 6.18: Summary of Base Station performance targets

| Physical channel | Measurement channel | Static | Multi-path Case 1 | Multi-path Case 2 | Multi-path Case 3 |
|------------------|---------------------|--------------------------------------------|--------------------------------------------|--------------------------------------------|---------------------------------------------------------------|
| | | Performance metric | | | |
| DCH | 12.2 kbps | BLER < 10 ⁻² | BLER < 10 ⁻² | BLER < 10 ⁻² | BLER < 10 ⁻² |
| | 64 kbps | BLER < 10 ⁻¹ , 10 ⁻² | BLER < 10 ⁻¹ , 10 ⁻² | BLER < 10 ⁻¹ , 10 ⁻² | BLER < 10 ⁻¹ , 10 ⁻² , 10 ⁻³ |
| | 144 kbps | BLER < 10 ⁻¹ , 10 ⁻² | BLER < 10 ⁻¹ , 10 ⁻² | BLER < 10 ⁻¹ , 10 ⁻² | BLER < 10 ⁻¹ , 10 ⁻² , 10 ⁻³ |
| | 384 kbps | BLER < 10 ⁻¹ , 10 ⁻² | BLER < 10 ⁻¹ , 10 ⁻² | BLER < 10 ⁻¹ , 10 ⁻² | BLER < 10 ⁻¹ , 10 ⁻² , 10 ⁻³ |

6.4.2 Demodulation in static propagation conditions

6.4.2.1 Demodulation of DCH

The performance requirement of DCH in static propagation conditions is determined by the maximum Block Error Rate (BLER) allowed when the receiver input signal is at a specified \hat{I}_{or}/I_{oc} limit. The BLER is calculated for each of the measurement channels supported by the base station.

6.4.2.1.1 Minimum requirement

For the parameters specified in Table 6.19 the BLER should not exceed the piece-wise linear BLER curve specified in Table 6.20.

Table 6.19: Parameters in static propagation conditions

| Parameters | Unit | Test 1 | Test 2 | Test 3 | Test 4 |
|------------------------------------|-------------|--------|--------|--------|--------|
| Number of DPCH _o | | 4 | 1 | 1 | 0 |
| Spread factor of DPCH _o | | 8 | 8 | 8 | - |
| $\frac{DPCH_o - E_c}{I_{or}}$ | DB | -7 | -7 | -7 | 0 |
| I_{oc} | DBm/1.28MHz | -91 | | | |
| Information Data Rate | Kbps | 12.2 | 64 | 144 | 384 |

Table 6.20: Performance requirements in AWGN channel.

| Test Number | $\frac{\hat{I}_{or}}{I_{oc}}$ [dB] | BLER Required E_b/N_0 |
|-------------|------------------------------------|-------------------------|
| 1 | 0.6 | 10^{-2} |
| 2 | -0.9 | 10^{-1} |
| | -0.4 | 10^{-2} |
| 3 | -0.3 | 10^{-1} |
| | -0.1 | 10^{-2} |
| 4 | 0.5 | 10^{-1} |
| | 0.6 | 10^{-2} |

6.4.3 Demodulation of DCH in multipath fading conditions

6.4.3.1 Multipath fading Case 1

The performance requirement of DCH in multipath fading Case 1 is determined by the maximum Block Error Rate (BLER) allowed when the receiver input signal is at a specified \hat{I}_{or}/I_{oc} limit. The BLER is calculated for each of the measurement channels supported by the base station.

6.4.3.1.1 Minimum requirement

For the parameters specified in Table 6.21 the BLER should not exceed the piece-wise linear BLER curve specified in Table 6.22.

Table 6.21: Parameters in multipath Case 1 channel

| Parameters | Unit | Test 1 | Test 2 | Test 3 | Test 4 |
|------------------------------------|--------------|--------|--------|--------|--------|
| Number of DPCH _o | | 4 | 1 | 1 | 0 |
| Spread factor of DPCH _o | | 8 | 8 | 8 | - |
| $\frac{DPCH_o - E_c}{I_{or}}$ | DB | -7 | -7 | -7 | 0 |
| I_{oc} | dBm/1.28 MHz | -91 | | | |
| Information Data Rate | Kbps | 12.2 | 64 | 144 | 384 |

Table 6.22: Performance requirements in multipath Case 1 channel.

| Test Number | $\frac{\hat{I}_{or}}{I_{oc}}$ [dB] | BLER |
|-------------|------------------------------------|-----------|
| 1 | 10.4 | 10^{-2} |
| 2 | 5.3 | 10^{-1} |
| | 9.4 | 10^{-2} |
| 3 | 5.7 | 10^{-1} |
| | 10.1 | 10^{-2} |
| 4 | 6.0 | 10^{-1} |
| | 10.0 | 10^{-2} |

6.4.3.2 Multipath fading Case 2

The performance requirement of DCH in multipath fading Case 2 is determined by the maximum Block Error Rate (BLER) allowed when the receiver input signal is at a specified \hat{I}_{or}/I_{oc} limit. The BLER is calculated for each of the measurement channels supported by the base station.

6.4.3.2.1 Minimum requirement

For the parameters specified in Table 6.4.6 the BLER should not exceed the piece-wise linear BLER curve specified in Table 6.4.7.

Table 6.23: Parameters in multipath Case 2 channel

| Parameters | Unit | Test 1 | Test 2 | Test 3 | Test 4 |
|------------------------------------|--------------|--------|--------|--------|--------|
| Number of DPCH _o | | 4 | 1 | 1 | 0 |
| Spread factor of DPCH _o | | 8 | 8 | 8 | - |
| $\frac{DPCH_{o} - E_c}{I_{or}}$ | DB | -7 | -7 | -7 | 0 |
| I_{oc} | dBm/1.28 MHz | -91 | | | |
| Information Data Rate | Kbps | 12.2 | 64 | 144 | 384 |

Table 6.24: Performance requirements in multipath Case 2 channel.

| Test Number | $\frac{\hat{I}_{or}}{I_{oc}}$ [dB] | BLER |
|-------------|------------------------------------|-----------|
| 1 | 6.7 | 10^{-2} |
| | 3.6 | 10^{-1} |
| 2 | 5.9 | 10^{-2} |
| | 4.2 | 10^{-1} |
| 3 | 6.3 | 10^{-2} |
| | 4.6 | 10^{-1} |
| 4 | 6.0 | 10^{-2} |

6.4.3.3 Multipath fading Case 3

The performance requirement of DCH in multipath fading Case 3 is determined by the maximum Block Error Rate (BLER) allowed when the receiver input signal is at a specified \hat{I}_{or}/I_{oc} limit. The BLER is calculated for each of the measurement channels supported by the base station.

6.4.3.3.1 Minimum requirement

For the parameters specified in Table 6.25 the BLER should not exceed the piece-wise linear BLER curve specified in Table 6.26.

Table 6.25: Parameters in multipath Case 3 channel

| Parameters | Unit | Test 1 | Test 2 | Test 3 | Test 4 |
|------------------------------------|--------------|--------|--------|--------|--------|
| Number of DPCH _o | | 4 | 1 | 1 | 0 |
| Spread factor of DPCH _o | | 8 | 8 | 8 | - |
| $\frac{DPCH_{o} - E_c}{I_{or}}$ | DB | -7 | -7 | -7 | 0 |
| I_{oc} | dBm/1.28 MHz | -91 | | | |
| Information Data Rate | Kbps | 12.2 | 64 | 144 | 384 |

Table 6.26: Performance requirements in multipath Case 3 channel.

| Test Number | $\frac{\hat{I}_{or}}{I_{oc}}$ [dB] | BLER |
|-------------|------------------------------------|-----------|
| 1 | 5.6 | 10^{-2} |
| 2 | 3.2 | 10^{-1} |
| | 4.6 | 10^{-2} |
| | 5.9 | 10^{-3} |
| 3 | 3.7 | 10^{-1} |
| | 4.8 | 10^{-2} |
| | 5.9 | 10^{-3} |
| 4 | 4.2 | 10^{-1} |
| | 5.1 | 10^{-2} |
| | 5.9 | 10^{-3} |

6.4.3.4 Explanation difference

The different performance requirement is result from different propagation condition (Annex D), different service mapping (Annex C), different simulation assumption and different chip rate with 3.84 Mcps chip rate TDD.

7 Base Station EMC

7.1 Test conditions

7.1.1 General

Common with 3.84 Mcps Chip rate TDD option.

7.1.2 Arrangements for establishing a communication link

Common with 3.84 Mcps Chip rate TDD option.

7.1.3 Narrow band responses on receivers

For 1.28 Mcps chip rate TDD option, responses on receivers or duplex transceivers occurring during the test at discrete frequencies which are narrow band responses (spurious responses), are identified by the following method:

if during an immunity test the quantity being monitored goes outside the specified tolerances, it is necessary to establish whether the deviation is due to a narrow band response or to a wide band (EMC) phenomenon. Therefore, the test shall be repeated with the unwanted signal frequency increased, and then decreased by 3.2MHz;

- if the deviation disappears in either or both of the above 3.2 MHz offset cases, then the response is considered as a narrow band response;
- if the deviation does not disappear, this may be due to the fact that the offset has made the frequency of the unwanted signal correspond to the frequency of another narrow band response. Under these circumstances the procedure is repeated with the increase and decrease of the frequency of the unwanted signal set to 4MHz;
- if the deviation does not disappear with the increased and/or decreased frequency, the phenomenon is considered wide band and therefore an EMC problem and the equipment fails the test.

Narrow band responses are disregarded.

7.2 Performance assessment

7.2.1 General

Common with 3.84 Mcps Chip rate TDD option.

7.2.2 Ancillary equipment

Common with 3.84 Mcps Chip rate TDD option.

7.3 Performance Criteria

7.3.1 Performance criteria A for continuous phenomena for BS

Common with 3.84 Mcps Chip rate TDD option.

7.3.2 Performance criteria B for transient phenomena for BS

Common with 3.84 Mcps Chip rate TDD option.

7.3.3 Performance criteria C for BS

Common with 3.84 Mcps Chip rate TDD option.

7.3.4 Performance criteria A for continuous phenomena for Ancillary equipment

Common with 3.84 Mcps Chip rate TDD option.

7.3.5 Performance criteria B for transient phenomena for Ancillary equipment

Common with 3.84 Mcps Chip rate TDD option.

7.3.6 Performance criteria C for Ancillary equipment

Common with 3.84 Mcps Chip rate TDD option.

7.4 Applicability overview

7.4.1 Emission

Common with 3.84 Mcps Chip rate TDD option.

7.4.2 Immunity

Common with 3.84 Mcps Chip rate TDD option.

8 BS conformance testing

8.1 Frequency bands and channel arrangement

8.1.1 General

The information presented in this section is based on a chip rate of 1.28 Mcps.

8.1.2 Frequency bands

Common with 3.84 Mcps TDD option.

8.1.3 TX–RX frequency separation

8.1.3.1 Description

No TX-RX frequency separation is required as Time Division Duplex (TDD) is employed. Each subframe of 1.28 Mcps TDD consists of 7 main timeslots (TS0 ~ TS6) where TS0 (before DL to UL switching point) are always allocated DL, the timeslots (at least the first one) before the switching point (vice versa) are allocated UL and the timeslots after the switching point (vice versa) are allocated DL.

8.1.3.2 Explanation of difference

The frame structure for 3.84 Mcps TDD and 1.28 Mcps TDD is different. For 3.84 Mcps TDD, each TDMA frame consists of 15 timeslots where each timeslot can be allocated to either transmit or receive.

8.1.4 Channel arrangement

8.1.4.1 Channel spacing

8.1.4.1.1 Background

The roll filter factor is would be 0.22, then we select the nominal bandwidth as 1.6MHz.

Considering the easy co-existence with Wide-band TDD mode, for its 3 times bandwidth would be 4.8, less than the nominal bandwidth of wide band UTRA TDD.

It is just nominal for 1.6MHz, and it is also flexible to adjust the channel raster step 200kHz to narrow as 1.4MHz for strict requirement situations if needed.

Considering the easy to implementation, for too narrow band of the bandwidth would be very difficult to implementation.

8.1.4.1.2 Channel spacing

The channel spacing for 1.28 Mcps chip rate option is 1.6MHz.

8.1.4.2 Channel raster

Common with 3.84 Mcps TDD option.

8.1.4.3 Channel number

Common with 3.84 Mcps TDD option.

8.2 General test conditions and declarations

8.2.1 Base station classes

Common with 3.84 Mcps TDD option.

8.2.2 Output power and determination of power class

Common with 3.84 Mcps TDD option.

8.2.3 Specified frequency range

Common with 3.84 Mcps TDD option.

8.2.4 Spectrum emission mask

Common with 3.84 Mcps TDD option.

8.2.5 Adjacent Channel Leakage power Ratio (ACLR)

Common with 3.84 Mcps TDD option.

8.2.6 Tx spurious emissions

8.2.6.1 Category of spurious emissions limit

Common with 3.84 Mcps TDD option.

8.2.6.2 Co-existence with GSM

Common with 3.84 Mcps TDD option.

8.2.6.3 Co-existence with DCS 1800

Common with 3.84 Mcps TDD option.

8.2.6.4 Co-existence with UTRA FDD

Common with 3.84 Mcps TDD option.

8.2.7 Blocking characteristics

Common with 3.84 Mcps TDD option.

8.2.8 Test environments

Common with 3.84 Mcps TDD option.

8.2.9 Interpretation of measurement results

Common with 3.84 Mcps TDD option.

8.2.10 Selection of configurations for testing

Common with 3.84 Mcps TDD option.

8.2.11 BS Configurations

Common with 3.84 Mcps TDD option.

8.2.12 Overview of the conformance test requirements

Common with 3.84 Mcps TDD option.

8.2.13 Format and interpretation of tests

Common with 3.84 Mcps TDD option.

8.3 Transmitter characteristics

8.3.1 General

Common with 3.84 Mcps TDD option.

8.3.2 Maximum output power

8.3.2.1 Definition and applicability

Common with 3.84 Mcps TDD option.

8.3.2.2 Conformance requirements

Common with 3.84 Mcps TDD option.

8.3.2.3 Test purpose

Common with 3.84 Mcps TDD option.

8.3.2.4 Method of test

8.3.2.4.1 Initial conditions

- a) Common with the 3.84 Mcps chip rate
- b) Common with the 3.84 Mcps chip rate
- c) Common with the 3.84 Mcps chip rate
- d) For 1.28 Mcps chip rate TDD option, set the parameters of the transmitted signal according to the following table.

Table 8.1: Parameters of the transmitted signal for maximum output power test for 1.28 Mcps chip rate TDD option

| Parameter | Value/description |
|----------------------------------|---------------------------------------------------------------------------------------------------|
| TDD Duty Cycle | TS i ; $i = 0, 1, 2, 3, 4, 5, 6$: transmit, if i is 0,4,5,6; receive, if i is 1,2,3. |
| BS output power setting | PRAT |
| Number of DPCH in each active TS | 8 |
| Power of each DPCH | 1/8 of Base Station output power |
| Data content of DPCH | real life (sufficient irregular) |

8.3.2.4.2 Procedure

- 1) Measure thermal power over the 848 active chips of a transmit time slot (this excludes the guard periods), and with a measurement bandwidth of at least 1.6 MHz.
- 2) Average over TBD time slots.
- 3) Run steps (1) and (2) for RF channels Low / Mid / High.

8.3.2.5 Test requirements

Common with 3.84 Mcps TDD option.

8.3.2.6 Explanation difference

For the 1.28 Mcps chip rate TDD option, one frame(10ms) consists of two subframes(5ms), and one subframe consists of 7 timeslots, the structure of the subframe is shown in section 7.2.1 of TR 25.928. So the number of timeslot i should be 0, 1, ..., 6. In addition, for the 1.28 Mcps chip rate TDD option, the DL reference measurement channel for 144kbits/s need two timeslots, each consists of 8 DPCH(SF=16).So the number of DPCH in each active TS should be 8.

For the 1.28 Mcps chip rate TDD option, each TS consists of 864 chips, but 16 chips is for Guard Period, so the measuring thermal power should over 848 active chips.

8.3.3 Frequency stability

8.3.3.1 Definition and applicability

Common with 3.84 Mcps TDD option.

8.3.3.2 Conformance requirement

Common with 3.84 Mcps TDD option.

8.3.3.3 Test purpose

Common with 3.84 Mcps TDD option.

8.3.3.4 Method of test

8.3.3.4.1 Initial conditions

- 1) Common with the 3.84 Mcps chip rate
- 2) Common with the 3.84 Mcps chip rate
- 3) Common with the 3.84 Mcps chip rate
- 4) For 1.28 Mcps chip rate TDD option, set the parameters of the transmitted signal according to the following table.

Table 8.2: Parameters of the transmitted signal for Frequency stability test for 1.28 Mcps chip rate TDD option

| Parameter | Value/description |
|----------------------------------|------------------------------------------------------------------------------------------------------|
| TDD Duty Cycle | TS i ; $i = 0, 1, 2, \dots, 6$: transmit, if i is 0, 4, 5, 6; receive, if i is 1, 2, 3. |
| Number of DPCH in each active TS | 1 |
| BS output power setting | PRAT |
| Data content of DPCH | real life (sufficient irregular) |

8.3.3.4.2 Procedure

- 1) Common with 3.84 Mcps chip rate TDD option.
- 2) Common with 3.84 Mcps chip rate TDD option.
- 3) Common with 3.84 Mcps chip rate TDD option.

8.3.3.5 Test requirement

Common with 3.84 Mcps TDD option.

9.3.3.6 Explanation difference

For the 1.28 Mcps chip rate TDD option, one frame(10ms) consists of two subframes(5ms), and one subframe consists of 7 timeslots, (the structure of the subframe is shown in section 7.2.1 of 3GPP TR 25.928), so the number of timeslot i should be 0, 1, ..., 6.

The frequency stability is a characteristic of the local oscillator and will not change, if the number of DPCH is varied. In these cases, it is felt that the use of only 1 DPCH will make the measurement easier and, at least for some parameters, more exact. Therefore, it is proposed to specify the test for frequency stability with 1 DPCH only also in the case of 1.28 Mcps TDD option.

8.3.4 Output power dynamics

8.3.4.1 Inner loop power control

Common with 3.84 Mcps TDD option.

8.3.4.2 Power control steps

8.3.4.2.1 Definition and applicability

Common with 3.84 Mcps TDD option.

8.3.4.2.2 Conformance requirements

Common with 3.84 Mcps TDD option.

8.3.4.2.3 Test purpose

Common with 3.84 Mcps TDD option.

8.3.4.2.4 Method of test

8.3.4.2.4.1 Initial conditions

- 1) Common with the 3.84 Mcps chip rate
- 2) Common with the 3.84 Mcps chip rate
- 3) For 1.28 Mcps chip rate TDD option, set the initial parameters of the transmitted signal according to the following table.
- 4) Common with the 3.84 Mcps chip rate
- 5) Common with the 3.84 Mcps chip rate

Table 8.3: Parameters of the transmitted signal for Power control step test for 1.28 Mcps chip rate TDD option

| Parameter | Value/description |
|----------------------------------|--------------------------------------------------------------------------------------------------|
| TDD Duty Cycle | TS i ; $i = 0, 1, 2, \dots, 6$: transmit, if i is 0, 4,5,6; receive, if i is 1,2,3. |
| Number of DPCH in each active TS | 1 |
| DPCH power | Minimum |
| Data content of DPCH | real life (sufficient irregular) |

8.3.4.2.4.2 Procedure

- 1) Common with 3.84 Mcps chip rate TDD option.
- 2) Set the BS tester to produce a sequence of TPC commands related to the active DPCH. This sequence shall be transmitted to the BS within the time slots TS $i=1,2,3$, and shall consist of a series of TPC commands with content "Increase Tx power", followed by a series of TPC commands with content "Decrease Tx power". Each of these series should be sufficiently long so that the transmit output power of the active DPCH is controlled to reach its maximum and its minimum, respectively.
- 3) Measure the power of the active DPCH over the 848 active chips of each time slot TS $i=0,4,5,6$ (-this excludes the guard period), and with a measurement filter that has a RRC filter response with a roll off $\alpha = 0,22$ and a bandwidth equal to the chip rate. The power is determined by calculating the RMS value of the signal samples at the measurement filter output taken at the decision points.
- 4) Common with 3.84 Mcps chip rate TDD option.
- 5) Common with 3.84 Mcps chip rate TDD option.

8.3.4.2.5 Test requirements

Common with 3.84 Mcps TDD option.

8.3.4.2.6 Explanation difference

For the 1.28 Mcps chip rate TDD option, one frame(10ms) consists of two subframes(5ms), and one subframe consists of 7 timeslots, (the Structure of subframe is shown in section 7.2.1 of 3GPP TR 25.928), so the number of timeslot i should be 0, 1, ..., 6.

For the 1.28 Mcps chip rate TDD option, each TS consists of 864 chips, but 16 chips is for Guard Period, so the measuring power should over 848 active chips.

8.3.4.3 Power control dynamic range

8.3.4.3.1 Definition and applicability

Common with 3.84 Mcps TDD option.

8.3.4.3.2 Conformance requirements

Common with 3.84 Mcps TDD option.

8.3.4.3.3 Test purpose

Common with 3.84 Mcps TDD option.

8.3.4.3.4 Method of test

8.3.4.3.4.1 Initial conditions

- 1) Common with the 3.84 Mcps chip rate
- 2) For 1.28 Mcps chip rate TDD option, set the initial parameters of the transmitted signal according to the following table.
- 3) Common with the 3.84 Mcps chip rate
- 4) Common with the 3.84 Mcps chip rate

Table 8.4: Parameters of the transmitted signal for Power control dynamic range test for 1.28 Mcps chip rate TDD option

| Parameter | Value/description |
|----------------------------------|--------------------------------------------------------------------------------------------------|
| TDD Duty Cycle | TS i ; $i = 0, 1, 2, \dots, 6$: transmit, if i is 0, 4,5,6; receive, if i is 1,2,3. |
| Number of DPCH in each active TS | 1 |
| Data content of DPCH | real life (sufficient irregular) |

8.3.4.3.4.2 Procedure

- 1) Common with 3.84 Mcps chip rate TDD option.
- 2) Set the BS tester to produce a sequence of TPC commands related to the active DPCH, with content "Increase Tx power". This sequence shall be sufficiently long so that the transmit output power of the active DPCH is controlled to reach its maximum, and shall be transmitted to the BS within the TS $i=1,2,3$ time slots.
- 3) Measure the power of the active DPCH over the 848 active chips of each time slot TS $i=0,4,5,6$ (this excludes the guard period), and with a measurement filter that has a RRC filter response with a roll off $\alpha = 0,22$ and a bandwidth equal to the chip rate. The power is determined by calculating the RMS value of the signal samples at the measurement filter output taken at the decision points.
- 4) Common with 3.84 Mcps chip rate TDD option.
- 5) Set the BS tester to produce a sequence of TPC commands related to the active DPCH, with content "Decrease Tx power". This sequence shall be sufficiently long so that the transmit output power of the active DPCH is controlled to reach its minimum, and shall be transmitted to the BS within the time slots TS $i=1,2,3$.
- 6) Measure the power of the active DPCH over the 848 active chips of each time slot TS $i=0,4,5,6$ (this excludes the guard period), and with a measurement filter that has a RRC filter response with a roll off $\alpha = 0,22$ and a bandwidth equal to the chip rate. The power is determined by calculating the RMS value of the signal samples at the measurement filter output taken at the decision points.

- 7) Common with 3.84 Mcps chip rate TDD option.
- 8) Common with 3.84 Mcps chip rate TDD option.
- 9) Common with 3.84 Mcps chip rate TDD option.

8.3.4.3.5 Test requirements

Common with 3.84 Mcps TDD option.

8.3.4.3.6 Explanation difference

For the 1.28 Mcps chip rate TDD option, one frame(10ms) consists of two subframes(5ms), and one subframe consists of 7 timeslots, (the structure of the subframe is shown in section7.2.1 of 3GPP TR 25.928), so the number of timeslot i should be 0, 1, ..., 6.

For the 1.28 Mcps chip rate TDD option, each TS consists of 864 chips, but 16 chips is for Guard Period,so the measuring power should over 848 active chips.

8.3.4.4 Minimum transmit power

8.3.4.4.1 Definition and applicability

Common with 3.84 Mcps TDD option.

8.3.4.4.2 Conformance requirements

Common with 3.84 Mcps TDD option.

8.3.4.4.3 Test purpose

Common with 3.84 Mcps TDD option.

8.3.4.4.4 Method of test

8.3.4.4.4.1 Initial conditions

- 1) Common with the 3.84 Mcps chip rate
- 2) For 1.28 Mcps chip rate TDD option, set the parameters of the transmitted signal according to the following table.
- 3) Common with the 3.84 Mcps chip rate
- 4) Common with the 3.84 Mcps chip rate

Table 8.5: Parameters of the transmitted signal for Minimum transmit power test for 1.28 Mcps chip rate TDD option

| Parameter | Value/description |
|----------------------------------|---------------------------------------------------------------------------------------------------|
| TDD Duty Cycle | TS i ; $i = 0, 1, 2, 3, 4, 5, 6$: transmit, if i is 0,4,5,6; receive, if i is 1,2,3. |
| BS output power setting | PRAT |
| Number of DPCH in each active TS | 8 |
| Power of each DPCH | 1/8 of Base Station output power |
| Data content of DPCH | real life (sufficient irregular) |

8.3.4.4.4.2 Procedure

- 1) Common with 3.84 Mcps chip rate TDD option.
- 2) Set the BS tester to produce a sequence of TPC commands related to all active DPCH, with content "Decrease Tx power". This sequence shall be sufficiently long so that the transmit output power of all active DPCH is controlled to reach its minimum, and shall be transmitted to the BS within the time slots TS $i=1,2,3$ (receive time slots of the BS).
- 3) Measure the power of the BS output signal over the 848 active chips of each time slot TS $i=0,4,5,6$ (this excludes the guard period), and with a measurement filter that has a RRC filter response with a roll off $\alpha = 0,22$ and a bandwidth equal to the chip rate. The power is determined by calculating the RMS value of the signal samples at the measurement filter output taken at the decision points.
- 4) Average over TBD time slots.
- 5) Common with 3.84 Mcps chip rate TDD option.

8.3.4.4.5 Test requirements

Common with 3.84 Mcps TDD option.

8.3.4.4.6 Explanation difference

For the 1.28 Mcps chip rate TDD option, one frame(10ms) consists of two subframes(5ms), and one subframe consists of 7 timeslots, the structure of subframe is shown in Section 7.2.1 of TR 25.928. So the number of timeslot i should be 0, 1, ..., 6. In addition, for the 1.28 Mcps chip rate TDD option, the DL reference measurement channel for 144kbps/s need two timeslots, each consists of 8 DPCH(SF=16). So the number of DPCH in each active TS should be 8.

For the 1.28 Mcps chip rate TDD option, each TS consists of 864 chips, but 16 chips is for Guard Period, so the measuring thermal power should over 848 active chips.

8.3.4.5 Primary CCPCH power

8.3.4.5.1 Definition and applicability

Common with 3.84 Mcps TDD option.

8.3.4.5.2 Conformance requirement

Common with 3.84 Mcps TDD option.

8.3.4.5.3 Test purpose

Common with 3.84 Mcps TDD option.

8.3.4.5.4 Method of test

8.3.4.5.4.1 Initial conditions

- 1) Common with the 3.84 Mcps chip rate
- 2) For 1.28 Mcps chip rate TDD option, set the parameters of the transmitted signal according to the following table.

Table 8.6: Parameters of the BS transmitted signal for Primary CCPCH power testing for 1.28 Mcps chip rate TDD option

| Parameter | Value/description |
|----------------------------|-------------------------------------------------------------------------------------------------|
| TDD Duty Cycle | TS i ; $i = 0, 1, 2, \dots, 6$: transmit, if i is 0,4,5,6; receive, if i is 1,2,3. |
| Time slots carrying PCCPCH | TS 0 |
| BS output power setting | PRAT |
| Relative power of PCCPCH | 1/2 of BS output power |
| Data content of DPCH | real life (sufficient irregular) |

8.3.4.5.4.2 Procedure

- 1) Measure the PCCPCH power in TS 0 by applying the global in-channel Tx test method described in Annex H.
- 2) Reduce the base station output power by 2 dB, 5 dB and 13 dB, without changing the relative powers of the PCCPCH, and repeat step (1) for each output power setting.

8.3.4.5.5 Test requirement

Common with 3.84 Mcps TDD option.

8.3.4.5.6 Explanation difference

For the 1.28 Mcps chip rate TDD option, one frame(10ms) consists of two subframes(5ms), and one subframe consists of 7 timeslots, the structure of subframe is shown in section 7.2.1 of TR 25.928. So the number of timeslot i should be 0, 1, ..., 6.

In 1.28 Mcps TDD option, likely scenario is that TS 0 is only used for broadcast, so no DPCH in TS 0.

8.3.5 Transmit ON/OFF power

8.3.5.1 Transmit OFF power

8.3.5.1.1 Definition and applicability

Common with 3.84 Mcps TDD option.

8.3.5.1.2 Conformance requirements

The transmit OFF power shall be less than -82 dBm measured with a filter that has a Root-Raised Cosine (RRC) filter response with a roll-off $\alpha = 0,22$ and a bandwidth equal to the chip rate.

8.3.5.1.3 Test purpose

Common with 3.84 Mcps TDD option.

8.3.5.1.4 Method of test

8.3.5.1.4.1 Initial conditions

The conformance testing of transmit OFF power is included in the conformance testing of transmit ON/OFF time mask; therefore, see subclause 8.3.5.2.4.1 for initial conditions.

8.3.5.1.4.2 Procedure

The conformance testing of transmit OFF power is included in the conformance testing of transmit ON/OFF time mask; therefore, see subclause 8.3.5.2.4.2 for procedure.

8.3.5.1.5 Test requirements

The conformance testing of transmit OFF power is included in the conformance testing of transmit ON/OFF time mask; therefore, see subclause 8.3.5.2.5 for test requirements.

8.3.5.2 Transmit ON/OFF time mask

8.3.5.2.1 Definition and applicability

Common with 3.84 Mcps TDD.

8.3.5.2.2 Conformance requirements

The transmit power level versus time should meet the mask specified in figure 8.1.

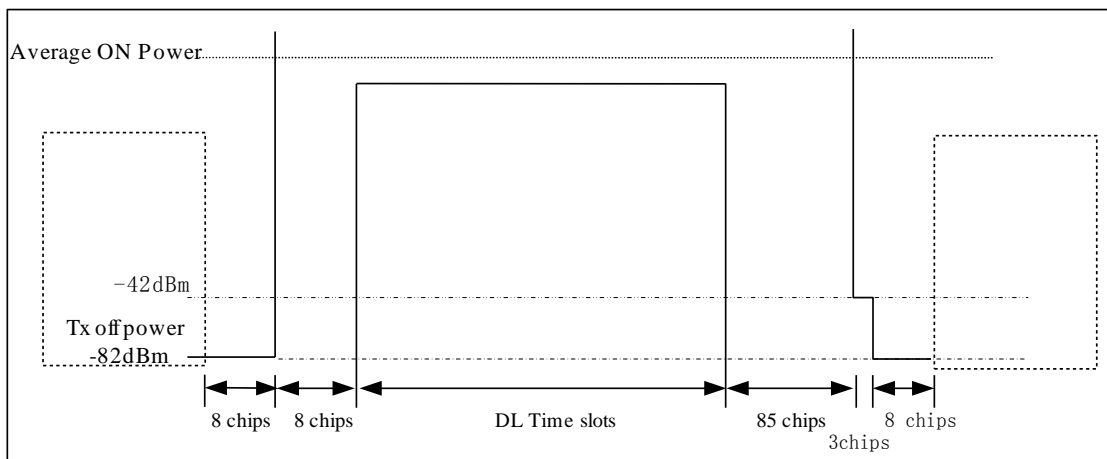

Figure 8.1: Transmit ON/OFF template for 1.28 Mcps TDD

The reference for this requirement is subclause 6.2.5.2 of this Technique Report.

8.3.5.2.3 Test purpose

Common with 3.84 Mcps TDD

8.3.5.2.4 Method of test

8.3.5.2.4.1 Initial conditions

- 1) Connect the power measuring equipment to the BS antenna connector.
- 2) Set the parameters of the transmitted signal according to table 8.7.

Table 8.7: Parameters of the transmitted signal for transmit ON/OFF time mask test for 1.28 Mcps TDD

| Parameter | Value/description |
|----------------------------------|------------------------------------------------------------------------------------------------------------|
| TDD Duty Cycle | TS i ; $i = 0, 1, 2, 3, 4, 5, 6$: transmit, if i is 0,4,5,6; receive, if i is UpPCH,1,2,3. |
| BS output power setting | PRAT |
| Number of DPCH in each active TS | 8 |
| Power of each DPCH | 1/8 of Base Station output power |
| Data content of DPCH | real life (sufficient irregular) |

8.3.5.2.4.2 Procedure

Measure the power of the BS output signal chipwise (i.e. averaged over time intervals of one chip duration) over the transmit off power period starting 11 chips before the start of the receive time slot TS $i = \text{UpPCH}$, and ending 8 chips before the next transmit time slot TS $i = 4$ starts, and with a measurement filter that has a RRC filter response with a roll off $\alpha = 0,22$ and a bandwidth equal to the chip rate. If the power measuring equipment is based on signal sampling, the sampling theorem shall be met. In this case, the power is determined by calculating the RMS value of the signal samples taken at the measurement filter output over one chip duration.

8.3.5.2.5 Test requirements

Each value of the power measured according to subclause 8.3.5.2.4.2 shall be below the limits defined in figure 8.3.5.2.2.1 of subclause 8.3.5.2.2.

8.3.5.2.6 Explanation difference

For the 1.28 Mcps chip rate TDD option, one frame(10ms) consists of two subframes(5ms), and one subframe consists of 7 timeslots, (the subframe is shown in section 7.2.1 of 3GPP TR 25.928, so the number of timeslot i should be 0, 1, ..., 6. In addition, for the 1.28 Mcps chip rate TDD option, the DL reference measurement channel for 144kbts/s need two timeslots, each consists of 8 DPCH(SF=16). So the number of DPCH in each active TS should be 8.

8.3.6 Output RF spectrum emissions

8.3.6.1 Occupied bandwidth

8.3.6.1.1 Definition and applicability

Common with 3.84 Mcps TDD option.

8.3.6.1.2 Conformance requirements

The occupied bandwidth shall be less than 1,6 MHz based on a chip rate of 1.28 Mcps.

8.3.6.1.3 Test purpose

Common with 3.84 Mcps TDD option.

8.3.6.1.4 Method of test

8.3.6.1.4.1 Initial conditions

- 1) Common with the 3.84 Mcps chip rate

- 2) For 1.28 Mcps chip rate TDD option, set the parameters of the transmitted signal according to the following table.

Table 8.8: Parameters of the transmitted signal for occupied bandwidth test for 1.28 Mcps chip rate TDD option

| Parameter | Value/description |
|----------------------------------|---------------------------------------------------------------------------------------------------|
| TDD Duty Cycle | TS i ; $i = 0, 1, 2, 3, 4, 5, 6$: transmit, if i is 0,4,5,6; receive, if i is 1,2,3. |
| BS output power setting | PRAT |
| Number of DPCH in each active TS | 8 |
| Power of each DPCH | 1/8 of Base Station output power |
| Data content of DPCH | real life (sufficient irregular) |

8.3.6.1.4.2 Procedure

- 1) Measure the power of the transmitted signal with a measurement filter of bandwidth 30 kHz. The characteristic of the filter shall be approximately Gaussian (typical spectrum analyzer filter). The center frequency of the filter shall be stepped in contiguous 30 kHz steps from a minimum frequency, which shall be $(2,4 - 0,015)$ MHz below the assigned channel frequency of the transmitted signal, up to a maximum frequency, which shall be $(2,4 + 0,015)$ MHz above the assigned channel frequency of the transmitted signal. The time duration of each step shall be sufficiently long to capture one active time slot. The measured power shall be recorded for each step.
- 2) Determine the transmitted power within the assigned channel bandwidth by accumulating the recorded power measurements results of all steps with center frequencies from $(0,8 - 0,015)$ MHz below the assigned channel frequency up to $(0,8 + 0,015)$ MHz above the assigned channel frequency.
- 3) Determine the total transmitted power by accumulating the recorded power measurements results of all steps.
- 4) Calculate the following ratio:
transmitted power within the assigned channel bandwidth acc. to (2) / total transmitted power acc. to (3).

8.3.6.1.5 Test requirements

Common with 3.84 Mcps TDD option.

8.3.6.1.6 Explanation difference

For the 1.28 Mcps chip rate TDD option, one frame(10ms) consists of two subframes(5ms), and one subframe consists of 7 timeslots, the structure of subframe is shown in section 7.2.1 of TR 25.928. So the number of timeslot i should be 0, 1, ..., 6. In addition, for the 1.28 Mcps chip rate TDD option, the DL reference measurement channel for 144kbts/s need two timeslots, each consists of 8 DPCH(SF=16). So the number of DPCH in each active TS should be 8.

8.3.6.2 Out of band emission

8.3.6.2.1 Spectrum emission mask

8.3.6.2.1.1 Definition and applicability

For 1.28 Mcps chip rate TDD option, the spectrum emission mask specifies the limit of the transmitter out of band emissions at frequency offsets from the assigned channel frequency of the wanted signal between 0,8 MHz and 4,0 MHz.

8.3.6.2.1.2 Conformance requirements

Emissions shall not exceed the maximum level specified in tables in Section 6.2.6.2.1 of TR 25.945.

8.3.6.2.1.3 Test purpose

The test purpose is to verify that the BS out of band emissions do not result in undue interference to any other system (wideband, narrowband) operating at frequencies close to the assigned channel bandwidth of the wanted signal.

This test is independent of the characteristics of possible victim systems and, therefore, complements the tests on occupied bandwidth in 8.3.6.1 of TR 25.945 (verifying the spectral concentration of the BS Tx emissions) and on ACLR in 8.3.6.2.2 of TR 25.945 (simulating the perception of other receivers).

8.3.6.2.1.4 Method of test

8.3.6.2.1.4.1 Initial conditions

- 1) Common with the 3.84 Mcps chip rate
- 2) For 1.28 Mcps chip rate TDD option, set the parameters of the transmitted signal according to the following table.

Table 8.9: Parameters of the transmitted signal for spectrum emission mask test for 1.28 Mcps chip rate TDD option

| Parameter | Value/description |
|----------------------------------|---------------------------------------------------------------------------------------------------|
| TDD Duty Cycle | TS i ; $i = 0, 1, 2, 3, 4, 5, 6$: transmit, if i is 0,4,5,6; receive, if i is 1,2,3. |
| BS output power setting | PRAT |
| Number of DPCH in each active TS | 8 |
| Power of each DPCH | 1/8 of Base Station output power |
| Data content of DPCH | real life (sufficient irregular) |

8.3.6.2.1.4.2 Procedure

Measure the power of the BS spectrum emissions by applying measurement filters with bandwidths as specified in the relevant table in subclause 8.3.6.2.1.2. The characteristic of the filters shall be approximately Gaussian (typical spectrum analyzer filters). The center frequency of the filter shall be stepped in contiguous steps over the frequency bands as given in the tables. The step width shall be equal to the respective measurement bandwidth. The time duration of each step shall be sufficiently long to capture one active time slot.

8.3.6.2.1.5 Test requirements

The spectrum emissions measured according to subclause 8.3.6.2.1.4.2 shall be within the mask defined in the relevant table of subclause 8.3.6.2.1.2.

8.3.6.2.1.6 Explanation difference

For the 1.28 Mcps chip rate TDD option, one frame(10ms) consists of two subframes(5ms), and one subframe consists of 7 timeslots, the structure of subframe is shown in section 7.2.1 of TR 25.928. So the number of timeslot i should be 0, 1,...,6. In addition, for the 1.28 Mcps chip rate TDD option, the DL reference measurement channel for 144kbts/s need two timeslots, each consists of 8 DPCH(SF=16).So the number of DPCH in each active TS should be 8.

8.3.6.2.2 Adjacent Channel Leakage power Ratio (ACLR)

8.3.6.2.2.1 Definition and applicability

Common with 3.84 Mcps TDD option.

8.3.6.2.2.2 Conformance requirements

The ACLR shall be equal to or greater than the limits given in Tables in section 6.2.6.2.2 of TR 25.945.

8.3.6.2.2.3 Test purpose

Common with 3.84 Mcps TDD option.

8.3.6.2.2.4 Method of test

8.3.6.2.2.4.1 Initial conditions

- 1) Common with the 3.84 Mcps chip rate
- 2) For 1.28 Mcps chip rate TDD option, set the parameters of the transmitted signal according to the following table.

Table 8.10: Parameters of the transmitted signal for ACLR test for 1.28 Mcps chip rate TDD option

| Parameter | Value/description |
|----------------------------------|---------------------------------------------------------------------------------------------------|
| TDD Duty Cycle | TS i ; $i = 0, 1, 2, 3, 4, 5, 6$: transmit, if i is 0,4,5,6; receive, if i is 1,2,3. |
| BS output power setting | PRAT |
| Number of DPCH in each active TS | 8 |
| Power of each DPCH | 1/8 of Base Station output power |
| Data content of DPCH | real life (sufficient irregular) |

8.3.6.2.2.4.2 Procedure

- 1) Measure transmitted power over the 848 active chips of the time slots TS $i=0,4,5,6$ (this excludes the guard period), and with a measurement filter that has a RRC filter response with a roll off $\alpha = 0,22$ and a bandwidth equal to the chip rate. The power is determined by calculating the RMS value of the signal samples at the measurement filter output taken at the decision points. (The global in-channel Tx test described in Annex C may be applied.)
- 2) Average over TBD time slots.
- 3) Measure interference power at the first lower adjacent RF channel (center frequency 1,6 MHz below the assigned channel frequency of the transmitted signal) over the useful part of the burst within the time slots TS $i=0,4,5,6$ (this excludes the guard period), and with a measurement filter that has a RRC filter response with a roll off $\alpha = 0,22$ and a bandwidth equal to the chip rate. The power is determined by calculating the RMS value of the signal samples at the measurement filter output taken with adherence to the sampling theorem.
- 4) Average over TBD time slots.
- 5) Calculate the ACLR by the ratio:

$$\text{CLR} = \text{transmitted power acc. to (2)} / \text{interference power acc. to (4)}.$$

- 6) repeat steps (3), (4) and (5) for the second lower adjacent RF channel (center frequency 3,2 MHz below the assigned channel frequency of the transmitted signal) and also for the first and second upper adjacent RF channel (center frequency 1,6 MHz and 3,2 MHz above the assigned channel frequency of the transmitted signal, respectively).

8.3.6.2.2.5 Test requirements

The ACLR calculated in step (5) of subclause 8.3.6.2.2.4.2 shall be equal or greater than the limits given in table 6.5 in section 6.2.6.2.2. In case of operation in proximity to or co-siting with TDD BS or FDD BS operating on an adjacent frequency, the interference power calculated in (4) shall be equal or less than the limits given in table 6.6 and 6.7 respectively, and the center frequency as well as the measurement bandwidth shall be equal to those listed in the corresponding tables.

8.3.6.2.2.6 Explanation difference

For the 1.28 Mcps chip rate TDD option, one frame(10ms) consists of two subframes(5ms), and one subframe consists of 7 timeslots, (the structure of subframe is shown in TR 25.928), so the number of timeslot i should be 0, 1, ..., 6. In addition, for the 1.28 Mcps chip rate TDD option, the DL reference measurement channel for 144kbits/s need two timeslots, each consists of 8 DPCH(SF=16). So the number of DPCH in each active TS should be 8.

For the 1.28 Mcps chip rate TDD option, each TS consists of 864 chips, but 16 chips is for Guard Period, so the measuring thermal power should be over 848 active chips.

8.3.6.3 Spurious emissions

8.3.6.3.1 Definition and applicability

Spurious emissions are emissions which are caused by unwanted transmitter effects such as harmonics emission, parasitic emission, intermodulation products and frequency conversion products, but exclude out of band emissions. This is measured at the base station RF output port.

The requirements in this subclause shall apply to base stations intended for general-purpose applications.

8.3.6.3.2 Conformance requirements

The requirements of either subclause 6.2.6.3.1 or subclause 6.2.6.3.2 shall apply whatever the type of transmitter considered (single carrier or multi-carrier). It applies for all transmission modes foreseen by the manufacturer.

Either requirement applies at frequencies within the specified frequency ranges which are more than 4 MHz under the first carrier frequency used or more than 4 MHz above the last carrier frequency used.

The power of any spurious emission shall not exceed the maximum level given in Tables in subclause 6.2.6.3.

8.3.6.3.3 Test purpose

The test purpose is to verify the ability of the BS to limit the interference caused by unwanted transmitter effects to other systems operating at frequencies which are more than 4 MHz away from of the UTRA band used.

8.3.6.3.4 Method of test

8.3.6.3.4.1 Initial conditions

- 1) Common with the 3.84 Mcps chip rate
- 2) For 1.28 Mcps chip rate TDD option, set the parameters of the transmitted signal according to the following table.

Table 8.11: Parameters of the transmitted signal for spurious emissions for 1.28 Mcps chip rate TDD option

| Parameter | Value/description |
|----------------------------------|---------------------------------------------------------------------------------------------------|
| TDD Duty Cycle | TS i ; $i = 0, 1, 2, 3, 4, 5, 6$: transmit, if i is 0,4,5,6; receive, if i is 1,2,3. |
| BS output power setting | PRAT |
| Number of DPCH in each active TS | 8 |
| Power of each DPCH | 1/8 of Base Station output power |
| Data content of DPCH | real life (sufficient irregular) |

8.3.6.3.4.2 Procedure

Measure the power of the spurious emissions by applying measurement filters with bandwidths as specified in the relevant tables of 8.3.6.3.2. The characteristic of the filters shall be approximately Gaussian (typical spectrum analyzer

filters). The center frequency of the filter shall be stepped in contiguous steps over the frequency bands as given in the tables. The step width shall be equal to the respective measurement bandwidth. The time duration of each step shall be sufficiently long to capture one active time slot.

8.3.6.3.5 Test requirements

The spurious emissions measured according to subclause 8.3.6.3.4.2 shall not exceed the limits specified in the relevant tables of 8.3.6.3.2.

8.3.6.3.6 Explanation difference

For the 1.28 Mcps chip rate TDD option, one frame(10ms) consists of two subframes(5ms), and one subframe consists of 7 timeslots, (the subframe is shown in section 7.2.1 of 3GPP TR 25.928), so the number of timeslot i should be 0, 1, ..., 6. In addition, for the 1.28 Mcps chip rate TDD option, the DL reference measurement channel for 144kbits/s need two timeslots, each consists of 8 DPCH(SF=16). So the number of DPCH in each active TS should be 8.

8.3.7 Transmit intermodulation

8.3.7.1 Definition and applicability

The transmit intermodulation performance is a measure of the capability of the transmitter to inhibit the generation of signals in its non linear elements caused by presence of the wanted signal and an interfering signal reaching the transmitter via the antenna.

The transmit intermodulation level is the power of the intermodulation products when a CDMA modulated interference signal is injected into the antenna connector at a level of 30 dB lower than that of the subject signal. The frequency of the interference signal shall be $\pm 1,6$ MHz, $\pm 3,2$ MHz and $\pm 4,8$ MHz offset from the subject signal.

The requirements in this subclause shall apply to base stations intended for general-purpose applications.

8.3.7.2 Conformance requirements

The transmit intermodulation level shall not exceed the out of band or the spurious emission requirements of subclause 8.3.6.2 and 8.3.6.3, respectively.

8.3.7.3 Test purpose

The test purpose is to verify the ability of the BS transmitter to restrict the generation of intermodulation products in its non linear elements caused by presence of the wanted signal and an interfering signal reaching the transmitter via the antenna to below specified levels.

8.3.7.4 Method of test

8.3.7.4.1 Initial conditions

- 1) Common with the 3.84 Mcps chip rate
- 2) For 1.28 Mcps chip rate TDD option, set the parameters of the transmitted signal according to the following table.

Table 8.12: Parameters of the transmitted signal for transmit intermodulation for 1.28 Mcps chip rate TDD option

| Parameter | Value/description |
|----------------------------------|---------------------------------------------------------------------------------------------------|
| TDD Duty Cycle | TS i ; $i = 0, 1, 2, 3, 4, 5, 6$: transmit, if i is 0,4,5,6; receive, if i is 1,2,3. |
| BS output power setting | PRAT |
| Number of DPCH in each active TS | 8 |
| Power of each DPCH | 1/8 of Base Station output power |
| Data content of DPCH | real life (sufficient irregular) |

- 3) Configure the CDMA signal generator to produce an interference signal with a level of 30 dB lower than that of the BS transmitted signal. The interference signal shall be like-modulated as the BS transmitted signal, and the active time slots of both signals shall be synchronized. The frequency of the interference signal shall be $\pm 1,6$ MHz, $\pm 3,2$ MHz and $\pm 4,8$ MHz offset from the BS transmitted signal.

8.3.7.4.2 Procedure

Apply the test procedures for out of band and spurious emissions as described in 8.3.6.2 and 8.3.6.3, respectively. The frequency band occupied by the interference signal are excluded from the measurements.

8.3.7.5 Test requirements

The conformance requirements for out of band and spurious emissions as specified in 8.3.6.2 and 8.3.6.3 shall be met.

8.3.7.6 Explanation difference

For the 1.28 Mcps chip rate TDD option, one frame(10ms) consists of two subframes(5ms), and one subframe consists of 7 timeslots, (the structure of the subframe is shown in section 7.2.1 of 3GPP TR 25.928), so the number of timeslot i should be 0, 1, ..., 6. In addition, for the 1.28 Mcps chip rate TDD option, the DL reference measurement channel for 144kbps/s need two timeslots, each consists of 8 DPCH(SF=16). So the number of DPCH in each active TS should be 8.

Because the bandwidth of 1.28 Mcps TDD option is 1,6MHz, the frequency offset of interference signal shall be $\pm 1,6$ MHz, $\pm 3,2$ MHz and $\pm 4,8$ MHz.

8.3.8 Transmit Modulation

8.3.8.1 Modulation accuracy

8.3.8.1.1 Definition and applicability

The modulation accuracy is a measure of the difference between the measured waveform and the theoretical modulated waveform (the error vector). A quantitative measure of the modulation accuracy is the error vector magnitude (EVM) which is defined as the square root of the ratio of the mean error vector power to the mean reference signal power expressed as %. The measurement interval is one timeslot.

The requirements in this subclause shall apply to base stations intended for general-purpose applications.

NOTE: The theoretical modulated waveform shall be calculated on the basis that the transmit pulse shaping filter is a root-raised cosine (RRC) with roll-off $\alpha = 0,22$ in the frequency domain. The impulse response of the chip impulse filter $RC_0(t)$ is:

$$RC_0(t) = \frac{\sin\left(\pi \frac{t}{T_c}(1-\alpha)\right) + 4\alpha \frac{t}{T_c} \cos\left(\pi \frac{t}{T_c}(1+\alpha)\right)}{\pi \frac{t}{T_c} \left(1 - \left(4\alpha \frac{t}{T_c}\right)^2\right)}$$

Where the roll-off factor $\alpha = 0,22$ and for 1.28 Mcps chip rate option the chip duration:

$$T_c = \frac{1}{\text{chiprate}} = 0.78125 \mu\text{s}$$

8.3.8.1.2 Conformance requirements

Common with 3.84 Mcps TDD option.

8.3.8.1.3 Test purpose

Common with 3.84 Mcps TDD option.

8.3.8.1.4 Method of test

8.3.8.1.4.1 Initial conditions

- 1) Common with the 3.84 Mcps chip rate
- 2) For 1.28 Mcps chip rate TDD option, set the parameters of the transmitted signal according to the following table.

Table 8.13: Parameters of the transmitted signal for modulation accuracy for 1.28 Mcps chip rate TDD option

| Parameter | Value/description |
|----------------------------------|-------------------------------------------------------------------------------------------------|
| TDD Duty Cycle | TS i ; $i = 0, 1, 2, \dots, 6$: Transmit, if i is 0,4,5,6; receive, if i is 1,2,3. |
| Number of DPCH in each active TS | 1 |
| Base station power | maximum, according to manufacturer's declaration |
| Data content of DPCH | real life (sufficient irregular) |

8.3.8.1.4.2 Procedure

Common with 3.84 Mcps Chip rate TDD option

8.3.8.1.5 Test requirements

Common with 3.84 Mcps TDD option.

8.3.8.1.6 Explanation difference

For the 1.28 Mcps chip rate TDD option, one frame(10ms) consists of two subframes(5ms), and one subframe consists of 7 timeslots, so the number of timeslot i should be 0, 1, ..., 6. The structure of subframe is shown in section 7.2.1 of TR 25.928.

8.3.8.2 Peak code domain error

8.3.8.2.1 Definition and applicability

Common with 3.84 Mcps TDD option.

8.3.8.2.2 Conformance requirements

Common with 3.84 Mcps TDD option.

8.3.8.2.3 Test purpose

Common with 3.84 Mcps TDD option.

8.3.8.2.4 Method of test

8.3.8.2.4.1 Initial conditions

- 1) Common with the 3.84 Mcps chip rate
- 2) For 1.28 Mcps chip rate TDD option, set the parameters of the transmitted signal according to the following table.

Table 8.14: Parameters of the transmitted signal for Peak code domain error for 1.28 Mcps chip rate TDD option

| Parameter | Value/description |
|----------------------------------|-------------------------------------------------------------------------------------------------|
| TDD Duty Cycle | TS i ; $i = 0, 1, 2, \dots, 6$: transmit, if i is 0,4,5,6; receive, if i is 1,2,3. |
| BS output power setting | PRAT |
| Number of DPCH in each active TS | 8 |
| Power of each DPCH | 1/8 of Base Station output power |
| Data content of DPCH | real life (sufficient irregular) |
| Spreading factor | 16 |

8.3.8.2.4.2 Procedure

Common with 3.84 Mcps Chip rate TDD option

8.3.8.2.5 Test requirements

Common with 3.84 Mcps TDD option.

8.3.8.2.6 Explanation difference

For the 1.28 Mcps chip rate TDD option, one frame(10ms) consists of two subframes(5ms), and one subframe consists of 7 timeslots, (the structure of subframe is shown in section 7.2.1 of 3GPP TR 25.928), so the number of timeslot i should be 0, 1, ..., 6. In addition, for the 1.28 Mcps chip rate TDD option, the DL reference measurement channel for 144kbps/s need two timeslots, each consists of 8 DPCH(SF=16). So the number of DPCH in each active TS should be 8.

8.4 Receiver characteristics

8.4.1 General

Common with 3.84 Mcps TDD option.

8.4.2 Reference sensitivity level

8.4.2.1 Definition and applicability

Common with 3.84 Mcps TDD option.

8.4.2.2 Conformance requirements

For the measurement channel specified in Annex 8.A.2.1, the reference sensitivity level and performance of the BS shall be as specified in table section 6.3.2.1 of TR 25.945.

8.4.2.3 Test purpose

Common with 3.84 Mcps TDD option.

8.4.2.4 Method of test

8.4.2.4.1 Initial conditions

- 1) Common with the 3.84 Mcps chip rate
- 2) Common with the 3.84 Mcps chip rate
- 3) Common with the 3.84 Mcps chip rate.
- 4) The level of BS tester output signal measured at the BS antenna connector shall be adjusted to -110 dBm.

8.4.2.4.2 Procedure

Common with 3.84 Mcps chip rate TDD option.

8.4.2.5 Test requirements

Common with 3.84 Mcps TDD option.

8.4.2.6 Explanation difference

There is no difference in the test method and test procedure between high chip rate TDD and low chip rate TDD, however the requirement is changed according to section 6.3.2.1 of TR 25.945.

8.4.3 Dynamic range

8.4.3.1 Definition and applicability

Common with 3.84 Mcps TDD option.

8.4.3.2 Conformance requirements

The BER shall not exceed 0,001 for the parameters specified in table in section 6.3.3 of TR 25.945.

8.4.3.3 Test purpose

Common with 3.84 Mcps TDD option.

8.4.3.4 Method of test

8.4.3.4.1 Initial conditions

- 1) Common with the 3.84 Mcps chip rate
- 2) The level of the BS tester output signal measured at the BS antenna connector shall be adjusted as specified in table in subclause 8.4.3.2
- 3) The power spectral density of the band-limited white noise source measured at the BS antenna connector shall be adjusted as specified in table in subclause 8.4.3.2. The minimum bandwidth of the white noise source shall be 1,5 times the chip rate (1,92 MHz for a chip rate of 1.28 Mcps).

8.4.3.4.2 Procedure

Common with 3.84 Mcps chip rate TDD option.

8.4.3.5 Test requirement

Common with 3.84 Mcps TDD option.

8.4.3.6 Explanation difference

Due to the smaller bandwidth in low chip rate TDD the bandwidth of the white noise source is changed.

8.4.4 Adjacent Channel Selectivity (ACS)

8.4.4.1 Definition and applicability

Common with 3.84 Mcps TDD option.

8.4.4.2 Conformance requirements

The BER, measured on the wanted signal in the presence of an interfering signal, shall not exceed 0,001 for the parameters specified in table in section 6.3.4 of TR 25.945.

8.4.4.3 Test purpose

Common with 3.84 Mcps TDD option.

8.4.4.4 Method of test

8.4.4.4.1 Initial conditions

Common with the 3.84 Mcps chip rate

Common with the 3.84 Mcps chip rate

Start transmission from the BS tester to the BS using the UL reference measurement channel (12.2 kbps) defined in Annex C.3. The level of the UE simulator signal measured at the BS antenna connector shall be adjusted to the value specified in table in subclause 8.4.4.2

Set the signal generator to produce an interfering signal that is equivalent to a continuous narrow band CDMA signal with one code of chip frequency 1.28 Mchip/s, filtered by an RRC transmit pulse-shaping filter with roll-off $\alpha = 0,22$ and 1.6MHz bandwidth. The level of the interfering signal measured at the BS antenna connector shall be adjusted to the value specified in table in subclause 8.4.4.2

8.4.4.4.2 Procedure

- 1) Set the center frequency of the interfering signal to 1,6 MHz above the assigned channel frequency of the wanted signal.
- 2) Measure the BER of the wanted signal at the BS receiver.
- 3) Set the center frequency of the interfering signal to 1,6 MHz below the assigned channel frequency of the wanted signal.
- 4) Measure the BER of the wanted signal at the BS receiver.
- 5) Interchange the connections of the BS Rx ports and repeat the measurements according to steps (1) to (4).

8.4.4.5 Test requirements

The BER measured according subclause 8.4.4.4.2 to shall not exceed 0,001.

8.4.4.6 Explanation difference

Because bandwidth of 1.28 Mcps TDD option is 1,6MHz, the frequency offset of the interfering signal should be 1,6MHz.

8.4.5 Blocking characteristics

8.4.5.1 Definition and applicability

The blocking characteristics is a measure of the receiver ability to receive a wanted signal at its assigned channel frequency in the presence of an unwanted interferer on frequencies other than those of the adjacent channels. The blocking performance shall apply at all frequencies as specified in tables in section 6.3.2 of TR 25.945 respectively, using a 1 MHz step size.

The requirements in this subclause shall apply to base stations intended for general-purpose applications.

8.4.5.2 Conformance requirements

The static reference performance as specified in the section 6.3.2 of TR 25.945 should be met with a wanted and an interfering signal coupled to the BS antenna input using the parameters specified in tables in section 6.3.5 of TR 25.945 respectively, using a 1 MHz step size..

8.4.5.3 Test purpose

The test stresses the ability of the BS receiver to withstand high-level interference from unwanted signals at frequency offsets of 3.2 MHz or more, without undue degradation of its sensitivity.

8.4.5.4 Method of test

8.4.5.4.1 Initial conditions

- 1) Connect an UE simulator operating at the assigned channel frequency of the wanted signal and a signal generator to the antenna connector of one Rx port.
- 2) Terminate or disable any other Rx port not under test.
- 3) Start transmission from the BS tester to the BS using the UL reference measurement channel (12.2 kbps) defined in Annex C.3. The level of the UE simulator signal measured at the BS antenna connector shall be set to 6 dB above the reference sensitivity level specified section 6.3.2.

8.4.5.4.2 Procedure

- 1) Set the signal generator to produce an interfering signal at a frequency offset F_{uw} from the assigned channel frequency of the wanted signal which is given by

$$F_{uw} = \pm (n \times 1 \text{ MHz}),$$

where n shall be increased in integer steps from $n = 10$ up to such a value that the center frequency of the interfering signal covers the range from 1 MHz to 12,75 GHz. The interfering signal level measured at the antenna connector shall be set in dependency of its center frequency, as specified in tables in section 6.3.5 of TR 25.945. respectively. The type of the interfering signal is either equivalent to a continuous narrow band CDMA signal with one code of chip frequency 1.28 Mchip/s, filtered by an RRC transmit pulse-shaping filter with roll-off $\alpha = 0,22$, or a CW signal; see tables in section 6.3.5 of TR 25.945 respectively.

- 2) Common with 3.84 Mcps chip rate TDD option.

8.4.5.5 Test requirements

In all measurements made according to subclause 8.4.5.4.2, the BER shall not exceed 0,001.

8.4.5.6 Explanation difference

Because the chip rate of the wanted signal is 1.28 Mcps, the type of the interfering signal is either equivalent to a continuous narrow band CDMA signal with one code of chip frequency 1.28 Mchip/s.

8.4.6 Intermodulation characteristics

8.4.6.1 Definition and applicability

Common with 3.84 Mcps TDD option.

8.4.6.2 Conformance requirements

The static reference performance as specified in clause 8.4.2 of TR 25.945 should be met when the following signals are coupled to the BS antenna input.

A wanted signal at the assigned channel frequency, 6 dB above the static reference level.

Two interfering signals with the parameters specified in following table.

Table 8.15: Parameters of the interfering signals for intermodulation characteristics testing of 1.28 Mcps TDD option

| Interfering Signal Level | Offset | Type of Interfering Signal |
|--------------------------|---------|----------------------------|
| - 48 dBm | 3,2 MHz | CW signal |
| - 48 dBm | 6,4 MHz | NCDMA signal with one code |

The reference for this requirement is subclause 6.3.6.

8.4.6.3 Test purpose

Common with 3.84 Mcps TDD option.

8.4.6.4 Method of test

8.4.6.4.1 Initial conditions

- 1) Common with 3.84 Mcps chip rate TDD option.
- 2) Common with 3.84 Mcps chip rate TDD option.
- 3) Start transmission from the BS tester to the BS using the UL reference measurement channel (12.2 kbps) defined in Annex 8.A.2 of TR 25.945 The level of the UE simulator signal measured at the BS antenna connector shall be set to 6 dB above the reference sensitivity level specified section 6.3.2 of TR 25.945.
- 4) Set the first signal generator to produce a CW signal with a level measured at the BS antenna connector of - 48 dBm.
- 5) Set the second signal generator to produce an interfering signal equivalent to a narrow band CDMA signal with one code of chip frequency 1.28 Mchip/s, filtered by an RRC transmit pulse-shaping filter with roll-off $\alpha = 0,22$. The level of the signal measured at the BS antenna connector shall be set to - 48 dBm.

8.4.6.4.2 Procedure

- 1) The frequency of the first and the second signal generator shall be set to 3,2 MHz and 6,4 MHz, respectively, above the assigned channel frequency of the wanted signal.
- 2) Measure the BER of the wanted signal at the BS receiver.

- 3) The frequency of the first and the second signal generator shall be set to 3,2 MHz and 6,4 MHz, respectively, below the assigned channel frequency of the wanted signal.
- 4) Measure the BER of the wanted signal at the BS receiver.
- 5) Interchange the connections of the BS Rx ports and repeat the measurements according to steps (1) to (4).

8.4.6.5 Test requirements

The BER measured according subclause 8.4.6.4.2 to shall not exceed 0,001.

8.4.6.6 Explanation difference

Because the bandwidth of 1.28 Mcps TDD is 1,6MHz, the frequency offsets of first and second interference signal should be 3,2MHz and 6,4MHz respectively.

8.4.7 Spurious emissions

8.4.7.1 Definition and applicability

Common with 3.84 Mcps TDD option.

8.4.7.2 Conformance requirements

The power of any spurious emission shall not exceed the values given in table in section 6.3.7 of TR 25.945

8.4.7.3 Test requirements

Common with 3.84 Mcps TDD option.

8.4.7.4 Method of test

8.4.7.4.1 Initial conditions

- 1) Common with the 3.84 Mcps chip rate
- 2) Common with the 3.84 Mcps chip rate
- 3) Common with the 3.84 Mcps chip rate
- 4) Set the BS to transmit a signal with parameters according to following table.
- 5) Common with the 3.84 Mcps chip rate

Table 8.16: Parameters of the transmitted signal for Rx spurious emissions test

| Parameter | Value/description |
|----------------------------------|-------------------------------------------------------------------------------------------------|
| TDD Duty Cycle | TS i ; $i = 0, 1, 2, \dots, 6$: transmit, if i is 0,4,5,6; receive, if i is 1,2,3. |
| BS output power setting | PRAT |
| Number of DPCH in each active TS | 8 |
| Power of each DPCH | 1/8 of Base Station output power |
| Data content of DPCH | real life (sufficient irregular) |

8.4.7.4.2 Procedure

- 1) Measure the power of the spurious emissions by applying the measuring equipment with the settings as specified in following table. The characteristics of the measurement filter with the bandwidth 1.28 MHz shall be RRC with roll-off $\alpha = 0,22$. The characteristics of the measurement filters with bandwidths 100 kHz and 1 MHz shall be approximately Gaussian (typical spectrum analyzer filter). The center frequency of the filters shall be stepped in contiguous steps over the frequency bands as specified in following table. The time duration of each step shall be sufficiently long to capture one transmit time slot.
- 2) If the BS is equipped with more than one Rx port, interchange the connections of the BS Rx ports and repeat the measurement according to (1).

Table 8.17: Measurement equipment settings

| Stepped frequency range | Measurement bandwidth | Step width | Note | Detection mode |
|-------------------------|-----------------------|------------|---------------------------------------------------------------------------------------------------------------------------------------------|----------------|
| 9 kHz – 1 GHz | 100 kHz | 100 kHz | With the exception of frequencies between 4 MHz below the first carrier frequency and 4 MHz above the last carrier frequency used by the BS | true RMS |
| 1 GHz – 1,900 GHz | 1 MHz | 1 MHz | | |
| 1,900 GHz – 1,980 GHz | 1.28 MHz | 200 kHz | | |
| 1,980 GHz – 2,010 GHz | 1 MHz | 1 MHz | | |
| 2,010 GHz – 2,025 GHz | 1.28 MHz | 200 kHz | | |
| 2,025 GHz – 12,75 GHz | 1 MHz | 1 MHz | | |

8.4.7.5 Test requirements

The spurious emissions measured according to subclause 8.4.7.4.2 shall not exceed the limits specified in subclause 8.4.7.2.

8.4.7.6 Explanation difference

For the 1.28 Mcps chip rate TDD option, one frame(10ms) consists of two subframes(5ms), and one subframe consists of 7 timeslots, the structure of subframe is shown in section 7.2.1 of TR 25.928. So the number of timeslot i should be 0, 1, ..., 6. In addition, for the 1.28 Mcps chip rate TDD option, the DL reference measurement channel for 144kbts/s need two timeslots, each consists of 8 DPCH(SF=16).So the number of DPCH in each active TS should be 8.

Due to the smaller bandwidth in low chip rate TDD the measurement bandwidth is changed.

8.5 Performance requirements

8.5.1 General

8.5.2 Demodulation in static propagation conditions

8.5.2.1 Demodulation of DCH

8.5.2.1.1 Definition and applicability

Common with 3.84 Mcps TDD.

8.5.2.1.2 Conformance requirements

For the parameters specified in table 8.18, the BLER should not exceed the piece-wise linear BLER curve specified in table 8.19.

Table 8.18: Parameters in static propagation conditions for 1.28 Mcps TDD option

| Parameters | Unit | Test 1 | Test 2 | Test 3 | Test 4 |
|------------------------------------|--------------|--------|--------|--------|--------|
| Number of DPCH ₀ | | 4 | 1 | 1 | 0 |
| Spread factor of DPCH ₀ | | 8 | 8 | 8 | |
| $\frac{DPCH_{0} - E_c}{I_{or}}$ | dB | -7 | -7 | -7 | - |
| I_{oc} | dBm/1.28 MHz | -91 | | | |
| Information Data Rate | kbps | 12,2 | 64 | 144 | 384 |

Table 8.19: Performance requirements in AWGN channel.

| Test Number | $\frac{\hat{I}_{or}}{I_{oc}}$ [dB] | BLER |
|-------------|------------------------------------|-----------|
| 1 | 0.6 | 10^{-2} |
| 2 | -0.9 | 10^{-1} |
| | -0.4 | 10^{-2} |
| 3 | -0.3 | 10^{-1} |
| | -0.1 | 10^{-2} |
| 4 | 0.5 | 10^{-1} |
| | 0.6 | 10^{-2} |

The reference for this requirement is TR 25.945 subclause 6.4.2.

8.5.2.1.3 Test purpose

Common with 3.84 Mcps TDD option.

8.5.2.1.4 Method of test

8.5.2.1.4.1 Initial conditions

Connect the BS tester (UE simulator) generating the wanted signal and a set of interference generators to both BS antenna connectors for diversity reception via a combining network. The set of interference generators comprises a number of CDMA generators, each representing an individual intracell interferer (subsequently called DPCH₀ generators) that the DPCH₀s are synchronous, and an additional band-limited white noise source, simulating interference from other cells. Each DPCH₀ generator shall produce an interfering signal that is equivalent to a valid 1.28 Mcps TDD signal with spreading factor 8, using the same time slot(s) than the wanted signal and applying the same cell-specific scrambling code. The number of the DPCH₀ generators used in each test is given in table 8.18.

8.5.2.1.4.2 Procedure

- 1) Adjust the power of the band-limited white noise source in such a way that its power spectral density measured at the BS antenna connector takes on the value I_{oc} as specified in table 8.18.
- 2) For a given test defined by the information data rate and the BLER objective, set the power of each DPCH₀ measured at the BS antenna connector during the active time slots to the value specified in table 8.20.
- 3) Set up a call between the BS tester generating the wanted signal and the BS. The characteristics of the call shall be configured according to the information data rate to be provided and the corresponding UL reference measurement channel defined in Annex 8.A. Depending on the information data rate, the UL reference measurement channel makes use of one or two Dedicated Physical Channels (DPCH₁ and DPCH₂) with different

spreading factors SF. The power(s) of DPCH₁ and DPCH₂ (if applicable) measured at the BS antenna connector during the active time slots shall be set to the value(s) given in table 8.20.

- 4) Measure the BLER of the wanted signal at the BS receiver.

Table 8.20: Parameters of DPCH₀ and the wanted signal

| Test Number | BLER objective | Number of DPCH ₀ | Power of each DPCH ₀ measured at the BS antenna connector [dBm] | Parameters of the wanted signal | | |
|-------------|------------------|-----------------------------|----------------------------------------------------------------------------|---------------------------------|----|--------------------------------------------------|
| | | | | DPCH | SF | Power measured at the BS antenna connector [dBm] |
| 1 | 10 ⁻² | 4 | -97.4 | DPCH ₁ | 8 | -97.4 |
| 2 | 10 ⁻¹ | 1 | -98.9 | DPCH ₁ | 2 | -92.9 |
| | 10 ⁻² | 1 | -98.4 | DPCH ₁ | 2 | -92.5 |
| 3 | 10 ⁻¹ | 1 | -98.3 | DPCH ₁ | 2 | -92.3 |
| | 10 ⁻² | 1 | -98.1 | DPCH ₁ | 2 | -92.1 |
| 4 | 10 ⁻¹ | 0 | - | DPCH ₁ | 8 | -97.5 |
| | | | | DPCH ₂ | 2 | -91.5 |
| | 10 ⁻² | 0 | - | DPCH ₁ | 8 | -97.4 |
| | | | | DPCH ₂ | 2 | -91.4 |

8.5.2.1.5 Test requirements

The BLER measured according to subclause 8.5.2.1.4.2 shall not exceed the limits specified in table 8.19.

8.5.2.1.6 Explanation difference

For the 1.28 Mcps chip rate TDD option, one frame(10ms) consists of two subframes(5ms), and one subframe consists of 7 timeslots, (the structure of subframe is shown in TR 25.928). Considering the chip rate, the burst structure of 1.28 Mcps TDD for normal traffic is different from that of 3.84 Mcps TDD option, (the burst structure for normal traffic is shown in TR 25.928). So the propagation conditions, service mapping and simulation assumption of the measurement channel 12.2kps, 64kps, 144kps and 384kps should be different from those of 3.84 Mcps TDD option. As a result, the relevant parameters should be different.

8.5.3 Demodulation of DCH in multipath fading conditions

8.5.3.1 Multipath fading Case 1

8.5.3.1.1 Definition and applicability

Common with 3.84 Mcps TDD option.

8.5.3.1.2 Conformance requirements

For the parameters specified in table 8.21, the BLER should not exceed the piece-wise linear BLER curve specified in table 8.22.

Table 8.21: Parameters multipath Case 1 channel for 1.28 Mcps TDD option

| Parameters | Unit | Test 1 | Test 2 | Test 3 | Test 4 |
|------------------------------------|--------------|--------|--------|--------|--------|
| Number of DPCH ₀ | | 4 | 1 | 1 | 0 |
| Spread factor of DPCH ₀ | | 8 | 8 | 8 | |
| $\frac{DPCH_o - E_c}{I_{or}}$ | dB | -7 | -7 | -7 | - |
| I_{oc} | dBm/1.28 MHz | -91 | | | |
| Information Data Rate | kbps | 12,2 | 64 | 144 | 384 |

Table 8.22: Performance requirements multipath Case 1 channel

| Test Number | $\frac{\hat{I}_{or}}{I_{oc}}$ [dB] | BLER |
|-------------|------------------------------------|-----------|
| 1 | 10.4 | 10^{-2} |
| 2 | 5.3 | 10^{-1} |
| | 9.4 | 10^{-2} |
| 3 | 5.7 | 10^{-1} |
| | 10.1 | 10^{-2} |
| 4 | 6.0 | 10^{-1} |
| | 10.0 | 10^{-2} |

The reference for this requirement is subclause 6.4.3.

8.5.3.1.3 Test purpose

Common with 3.84 Mcps TDD option.

8.5.3.1.4 Method of test

8.5.3.1.4.1 Initial conditions

- 1) Connect the BS tester (UE simulator) generating the wanted signal and a set of interference generators to both BS antenna connectors for diversity reception via a combining network. The set of interference generators comprises a number of CDMA generators, each representing an individual intracell interferer (subsequently called DPCH₀ generators) that the DPCH₀s are synchronous, and an additional band-limited white noise source, simulating interference from other cells. Each DPCH₀ generator shall produce an interfering signal that is equivalent to a valid 1.28 Mcps TDD signal with spreading factor 8, using the same time slot(s) than the wanted signal and applying the same cell-specific scrambling code. The number of the DPCH₀ generators used in each test is given in table 8.21.
- 2) The wanted signal produced by the BS tester and the interfering signals produced by the DPCH₀ generators are individually passed through independent Multipath Fading Simulators (MFS) before entering the combining network. Each MFS shall be configured to simulate multipath fading Case 1.

8.5.3.1.4.2 Procedure

- 1) Adjust the power of the band-limited white noise source in such a way that its power spectral density measured at the BS antenna connector takes on the value I_{oc} as specified in table 8.21.
- 2) For a given test defined by the information data rate and the BLER objective, set the power of each DPCH₀ measured at the BS antenna connector during the active time slots to the value specified in table 8.21.
- 3) Set up a call between the BS tester generating the wanted signal and the BS. The characteristics of the call shall be configured according to the information data rate to be provided and the corresponding UL reference measurement channel defined in Annex C.3. Depending on the information data rate, the UL reference measurement channel makes use of one or two Dedicated Physical Channels (DPCH₁ and DPCH₂) with different spreading factors SF. The power(s) of DPCH₁ and DPCH₂ (if applicable) measured at the BS antenna connector during the active time slots shall be set to the value(s) given in table 8.23.
- 4) Measure the BLER of the wanted signal at the BS receiver.

Table 8.23: Parameters of DPCH₀ and the wanted signal

| Test Number | BLER objective | Number of DPCH ₀ | Power of each DPCH ₀ measured at the BS antenna connector [dBm] | Parameters of the wanted signal | | |
|-------------|------------------|-----------------------------|----------------------------------------------------------------------------|---------------------------------|----|--------------------------------------------------|
| | | | | DPCH | SF | Power measured at the BS antenna connector [dBm] |
| 1 | 10 ⁻² | 4 | -87.6 | DPCH ₁ | 8 | -87.6 |
| 2 | 10 ⁻¹ | 1 | -92.7 | DPCH ₁ | 2 | -86.7 |
| | 10 ⁻² | 1 | -88.6 | DPCH ₁ | 2 | -82.6 |
| 3 | 10 ⁻¹ | 1 | -92.3 | DPCH ₁ | 2 | -86.3 |
| | 10 ⁻² | 1 | -87.9 | DPCH ₁ | 2 | -81.9 |
| 4 | 10 ⁻¹ | 0 | - | DPCH ₁ | 8 | -92.0 |
| | | | | DPCH ₂ | 2 | -86.0 |
| | 10 ⁻² | 0 | - | DPCH ₁ | 8 | -88.0 |
| | | | | DPCH ₂ | 2 | -82.0 |

8.5.3.1.5 Test requirements

The BLER measured according to subclause 8.5.3.1.4.2 shall not exceed the limits specified in table 8.22.

8.5.3.1.6 Explanation difference

For the 1.28 Mcps chip rate TDD option, one frame(10ms) consists of two subframes(5ms), and one subframe consists of 7 timeslots, (the structure of subframe is shown in TR 25.928). Considering the chip rate, the burst structure of 1.28 Mcps TDD for normal traffic is different from that of 3.84 Mcps TDD option, (the burst structure for normal traffic is shown in TR 25.928). So the propagation conditions, service mapping and simulation assumption of the measurement channel 12.2kps, 64kps, 144kps and 384kps should be different from those of 3.84 Mcps TDD option. As a result, the relevant parameters should be different.

8.5.3.2 Multipath fading Case 2

8.5.3.2.1 Definition and applicability

Common with 3.84 Mcps TDD option.

8.5.3.2.2 Conformance requirements

For the parameters specified in table 8.24, the BLER should not exceed the piece-wise linear BLER curve specified in table 8.25.

Table 8.24: Parameters multipath Case 2 channel for 1.28 Mcps TDD option

| Parameters | Unit | Test 1 | Test 2 | Test 3 | Test 4 |
|------------------------------------|--------------|--------|--------|--------|--------|
| Number of DPCH ₀ | | 4 | 1 | 1 | 0 |
| Spread factor of DPCH ₀ | | 8 | 8 | 8 | |
| $\frac{DPCH_o - E_c}{I_{or}}$ | dB | -7 | -7 | -7 | - |
| I_{oc} | dBm/1.28 MHz | -91 | | | |
| Information Data Rate | kbps | 12,2 | 64 | 144 | 384 |

Table 8.25: Performance requirements multipath Case 2 channel.

| Test Number | $\frac{\hat{I}_{or}}{I_{oc}}$ [dB] | BLER |
|-------------|------------------------------------|-----------|
| 1 | 6.7 | 10^{-2} |
| 2 | 3.6 | 10^{-1} |
| | 5.9 | 10^{-2} |
| 3 | 4.2 | 10^{-1} |
| | 6.3 | 10^{-2} |
| 4 | 4.6 | 10^{-1} |
| | 6.0 | 10^{-2} |

The reference for this requirement is subclause 6.4.3.

8.5.3.2.3 Test purpose

Common with 3.84 Mcps TDD option.

8.5.3.2.4 Method of test

8.5.3.2.4.1 Initial conditions

- 1) Connect the BS tester (UE simulator) generating the wanted signal and a set of interference generators to both BS antenna connectors for diversity reception via a combining network. The set of interference generators comprises a number of CDMA generators, each representing an individual intracell interferer (subsequently called DPCH₀ generators) that the DPCH₀s are synchronous, and an additional band-limited white noise source, simulating interference from other cells. Each DPCH₀ generator shall produce an interfering signal that is equivalent to a valid 1.28 Mcps TDD signal with spreading factor 8, using the same time slot(s) than the wanted signal and applying the same cell-specific scrambling code. The number of the DPCH₀ generators used in each test is given in table 8.24.
- 2) The wanted signal produced by the BS tester and the interfering signals produced by the DPCH₀ generators are individually passed through independent Multipath Fading Simulators (MFS) before entering the combining network. Each MFS shall be configured to simulate multipath fading Case 2.

8.5.3.2.4.2 Procedure

- 1) Adjust the power of the band-limited white noise source in such a way that its power spectral density measured at the BS antenna connector takes on the value I_{oc} as specified in table 8.24.
- 2) For a given test defined by the information data rate and the BLER objective, set the power of each DPCH₀ measured at the BS antenna connector during the active time slots to the value specified in table 8.26.
- 3) Set up a call between the BS tester generating the wanted signal and the BS. The characteristics of the call shall be configured according to the information data rate to be provided and the corresponding UL reference measurement channel defined in Annex C.3. Depending on the information data rate, the UL reference measurement channel makes use of one or two Dedicated Physical Channels (DPCH₁ and DPCH₂) with different spreading factors SF. The power(s) of DPCH₁ and DPCH₂ (if applicable) measured at the BS antenna connector during the active time slots shall be set to the value(s) given in table 8.26.
- 4) Measure the BLER of the wanted signal at the BS receiver.

Table 8.26: Parameters of DPCH₀ and the wanted signal

| Test Number | BLER objective | Number of DPCH ₀ | Power of each DPCH ₀ measured at the BS antenna connector [dBm] | Parameters of the wanted signal | | |
|-------------|------------------|-----------------------------|----------------------------------------------------------------------------|---------------------------------|----|--------------------------------------------------|
| | | | | DPCH | SF | Power measured at the BS antenna connector [dBm] |
| 1 | 10 ⁻² | 4 | -91.3 | DPCH ₁ | 8 | -91.3 |
| 2 | 10 ⁻¹ | 1 | -94.4 | DPCH ₁ | 2 | -88.4 |
| | 10 ⁻² | 1 | -92.1 | DPCH ₁ | 2 | -86.1 |
| 3 | 10 ⁻¹ | 1 | -93.8 | DPCH ₁ | 2 | -87.8 |
| | 10 ⁻² | 1 | -91.7 | DPCH ₁ | 2 | -85.7 |
| 4 | 10 ⁻¹ | 0 | - | DPCH ₁ | 8 | -93.4 |
| | | | | DPCH ₂ | 2 | -87.4 |
| | 10 ⁻² | 0 | - | DPCH ₁ | 8 | -92.0 |
| | | | | DPCH ₂ | 2 | -86.0 |

8.5.3.2.5 Test requirements

The BLER measured according to subclause 8.5.3.2.4.2 shall not exceed the limits specified in table 8.25.

8.5.3.2.6 Explanation difference

For the 1.28 Mcps chip rate TDD option, one frame(10ms) consists of two subframes(5ms), and one subframe consists of 7 timeslots, (the structure of subframe is shown in TR 25.928). Considering the chip rate, the burst structure of 1.28 Mcps TDD for normal traffic is different from that of 3.84 Mcps TDD option, (the burst structure for normal traffic is shown in TR 25.928). So the propagation conditions, service mapping and simulation assumption of the measurement channel 12.2kps, 64kps, 144kps and 384kps should be different from those of 3.84 Mcps TDD option. As a result, the relevant parameters should be different.

8.5.3.3 Multipath fading Case 3

8.5.3.3.1 Definition and applicability

Common with 3.84 Mcps TDD option.

8.5.3.3.2 Conformance requirements

For the parameters specified in table 8.27, the BLER should not exceed the piece-wise linear BLER curve specified in table 8.28.

Table 8.27: Parameters multipath Case 3 channel for 1.28 Mcps TDD option

| Parameters | Unit | Test 1 | Test 2 | Test 3 | Test 4 |
|------------------------------------|--------------|--------|--------|--------|--------|
| Number of DPCH ₀ | | 4 | 1 | 1 | 0 |
| Spread factor of DPCH ₀ | | 8 | 8 | 8 | |
| $\frac{DPCH_o - E_c}{I_{or}}$ | dB | -7 | -7 | -7 | - |
| I_{oc} | dBm/1.28 MHz | -91 | | | |
| Information Data Rate | kbps | 12,2 | 64 | 144 | 384 |

Table 8.28: Performance requirements multipath Case 3 channel.

| Test Number | $\frac{\hat{I}_{or}}{I_{oc}}$ [dB] | BLER |
|-------------|------------------------------------|-----------|
| 1 | 5.6 | 10^{-2} |
| 2 | 3.2 | 10^{-1} |
| | 4.6 | 10^{-2} |
| | 5.9 | 10^{-3} |
| 3 | 3.7 | 10^{-1} |
| | 4.8 | 10^{-2} |
| | 5.9 | 10^{-3} |
| 4 | 4.2 | 10^{-1} |
| | 5.1 | 10^{-2} |
| | 5.9 | 10^{-3} |

The reference for this requirement is subclause 6.4.3.

8.5.3.3.3 Test purpose

Common with 3.84 Mcps TDD option.

8.5.3.3.4 Method of test

8.5.3.3.4.1 Initial conditions

- 1) Connect the BS tester (UE simulator) generating the wanted signal and a set of interference generators to both BS antenna connectors for diversity reception via a combining network. The set of interference generators comprises a number of CDMA generators, each representing an individual intracell interferer (subsequently called DPCH₀ generators) that the DPCH₀s are synchronous, and an additional band-limited white noise source, simulating interference from other cells. Each DPCH₀ generator shall produce an interfering signal that is equivalent to a valid 1.28 Mcps TDD signal with spreading factor 8, using the same time slot(s) than the wanted signal and applying the same cell-specific scrambling code. The number of the DPCH₀ generators used in each test is given in table 8.27.
- 2) The wanted signal produced by the BS tester and the interfering signals produced by the DPCH₀ generators are individually passed through independent Multipath Fading Simulators (MFS) before entering the combining network. Each MFS shall be configured to simulate multipath fading Case 3.

8.5.3.3.4.2 Procedure

- 1) Adjust the power of the band-limited white noise source in such a way that its power spectral density measured at the BS antenna connector takes on the value I_{oc} as specified in table 8.27.
- 2) For a given test defined by the information data rate and the BLER objective, set the power of each DPCH₀ measured at the BS antenna connector during the active time slots to the value specified in table 8.29.
- 3) Set up a call between the BS tester generating the wanted signal and the BS. The characteristics of the call shall be configured according to the information data rate to be provided and the corresponding UL reference measurement channel defined in Annex C.3. Depending on the information data rate, the UL reference

measurement channel makes use of one or two Dedicated Physical Channels (DPCH₁ and DPCH₂) with different spreading factors SF. The power(s) of DPCH₁ and DPCH₂ (if applicable) measured at the BS antenna connector during the active time slots shall be set to the value(s) given in table 8.29.

- 4) Measure the BLER of the wanted signal at the BS receiver.

Table 8.29: Parameters of DPCH₀ and the wanted signal

| Test Number | BLER objective | Number of DPCH ₀ | Power of each DPCH ₀ measured at the BS antenna connector [dBm] | Parameters of the wanted signal | | |
|-------------|------------------|-----------------------------|----------------------------------------------------------------------------|---------------------------------|----|--------------------------------------------------|
| | | | | DPCH | SF | Power measured at the BS antenna connector [dBm] |
| 1 | 10 ⁻² | 4 | -92.4 | DPCH ₁ | 8 | -92.4 |
| 2 | 10 ⁻¹ | 1 | -94.8 | DPCH ₁ | 2 | -88.8 |
| | 10 ⁻² | 1 | -93.4 | DPCH ₁ | 2 | -87.4 |
| | 10 ⁻³ | 1 | -92.1 | DPCH ₁ | 2 | -86.1 |
| 3 | 10 ⁻¹ | 1 | -94.3 | DPCH ₁ | 2 | -88.3 |
| | 10 ⁻² | 1 | -93.2 | DPCH ₁ | 2 | -87.2 |
| | 10 ⁻³ | 1 | -92.1 | DPCH ₁ | 2 | -86.1 |
| 4 | 10 ⁻¹ | 0 | - | DPCH ₁ | 8 | -93.8 |
| | | | | DPCH ₂ | 2 | -87.8 |
| | 10 ⁻² | 0 | - | DPCH ₁ | 8 | -92.9 |
| | | | | DPCH ₂ | 2 | -86.9 |
| | 10 ⁻³ | 0 | - | DPCH ₁ | 8 | -92.1 |
| | | | | DPCH ₂ | 2 | -86.1 |

8.5.3.3.5 Test requirements

The BLER measured according to subclause 8.5.3.3.4.2 shall not exceed the limits specified in table 8.28.

8.5.3.3.6 Explanation difference

For the 1.28 Mcps chip rate TDD option, one frame(10ms) consists of two subframes(5ms), and one subframe consists of 7 timeslots, (the structure of subframe is shown in TR 25.928). Considering the chip rate, the burst structure of 1.28 Mcps TDD for normal traffic is different from that of 3.84 Mcps TDD option, (the burst structure for normal traffic is shown in TR 25.928). So the propagation conditions, service mapping and simulation assumption of the measurement channel 12.2kps, 64kps, 144kps and 384kps should be different from those of 3.84 Mcps TDD option. As a result, the relevant parameters should be different.

9 RF System scenarios

9.1 General

To develop the 3GPP standard, all the relevant scenarios need to be considered and the most critical cases need to be identified for the various aspects of operation so that final parameters can be derived to meet both service and implementation requirements.

Parameters possibly influenced by the scenarios are listed in 25.102, 25.105 and 25.945. These include, but are not limited to:

- Out of band emissions;
- Spurious emissions;
- Intermodulation rejection;
- Intermodulation between MS;
- Blocking.

9.2 Methodology for coexistence studies 1.28 Mcps TDD/FDD

9.2.1 Overview of the simulation

The focus of the simulations in the first step is on coexistence of macro cells considering a vehicular environment (case 3: 120km/h) with speech users only.

The simulation is a Monte-Carlo based snapshot method calculating CDFs for C/I for large numbers of stochastic mobile distributions over cells (including power control).

It should be pointed out that no kind of synchronisation or coordination between the different systems is assumed in the coexistence simulations presented here and before.

The goal of simulation procedure is to determine the relative capacity loss of a victim system for a considered link (uplink or downlink) due to the presence of a second system – the interfering system. The reference for the capacity loss is the capacity of the victim system alone without the interfering system.

The **capacity of the system** is defined as the mean number of mobile stations per cell (i.e. the load in different cells may be different while the mean load, i.e. the total number of users in the simulated scenario, remains constant) that can be active at a time while the probability that the C/I of a mobile station falls below a given threshold C/I_{\min} is below 5% (i.e. the percentage of users which do not satisfy the C/I criteria for the speech service is 5%).

This definition is different but strongly related to the so-called “satisfied user criterion” (i.e. 98% of all users have to be able to complete their call without being dropped due to interference). However the “satisfied user criterion” requires the mapping of C/I to BER/BLER values and time-continuous simulation techniques, while here a Monte Carlo snapshot method is used.

The simulation is done in two steps:

At first N_{single} the capacity of the **single operator** case (i.e. only the victim system is present) is determined which means that the capacity depends on the co-channel interference (i.e. there is no adjacent channel interference).

The co-channel interference power itself depends on a number of parameters, especially on the number of mobiles, their position and their power control behaviour. N_{single} is the maximum mean number of mobiles per cell that can be active at a time in the single operator case.

The second step is the calculation of the **multi operator** capacity (i.e. victim and interferer system are present) which means the maximum mean number of mobiles per cell N_{multi} in the victim system that can be active at a time considering co-channel and adjacent channel interference.

To determine N_{multi} the multi operator simulation is started with $N_{multi} = N_{single}$. Due to the additional adjacent channel interference the outage of users with C/I below the threshold C/I_{min} is increased compared to the single operator case (5%).

By decreasing N_{multi} until the outage of 5% is reached again the capacity loss due to adjacent channel interference can be determined.

(The number of users in the interfering system is chosen in that way that a single operator simulation with this system would result in an outage of 5%.)

Finally the relative capacity loss can be calculated as

$$C = 1 - \frac{N_{multi}}{N_{single}}$$

9.2.2 Simulation parameters

Table 9.1: Receiver Parameters

| No. | parameter | | FDD | | 1.28 Mcps TDD | |
|-----|--------------------------------|-----|-------|-------|---------------|------|
| | | | MS | BS | MS | BS |
| RX1 | Sensitivity | dBm | -117 | -121 | -108 | -110 |
| RX2 | Noise figure | dB | 9 | 5 | 9 | 7 |
| RX3 | Antenna gain (incl. losses) | dBi | 0 | 11 | 0 | 11 |
| RX4 | ACS | dB | 33 | 45 | 33 | 45 |
| RX5 | Min. CIR for 8kbps speech | dB | -15.7 | -20.9 | -1.5 | -6.7 |

Table 9.2: Transmitter Parameters

| No. | Parameter | | FDD | | 1.28 Mcps TDD | |
|-----|--------------------------------------|-----|------------------|------------------|------------------|------------------|
| | | | MS | BS | MS | BS |
| TX1 | Max. TX power | dBm | 21 | 43 (27 per user) | 30 | 43 (33 per user) |
| TX2 | Min. Tx power per user | dBm | -50 | 27-25=2 | -44 | 33-30=3 |
| TX3 | Antenna gain | dB | See RX3 | | | |
| TX4 | PC dynamic range (1 code considered) | dB | Max - (-50) = 71 | 25 | Max - (-44) = 74 | 30 |
| TX5 | ACLR | dB | 33 (43) | 45 (50) | 33 (43) | 40 (50) |

This section compares the different RF parameters for FDD and 1.28 Mcps TDD which are used to describe the "victim system" and the "interferer system" in the coexistence simulation scenarios.

As a first step concerning the minimum C/I ratio values of the 1.28 Mcps TDD system the following results were used:

- UL (i.e. receiving BS): $C/I_{min} = -4.9$ dB
- DL (i.e. receiving MS): $C/I_{min} = 0.3$ dB.

Considering the mapping of the information data bits for the 12.2kbps service in UL and DL: 244 bits are mapped on 536 bits. We assumed in a first approach that for a 8kbps speech service $244 * (8\text{kbps}/12.2\text{kbps})$ bits are mapped on 536 bits which results in a subtraction of 1.83dB for the both C/I_{min} values mentioned before which finally leads to the values in the table.

The ACLR and ACS values were taken from the specifications TS 25.101, TS 25.102, TS 25.104, TS 25.105 and this report.

For the investigations the cluster size of the 1.28 Mcps TDD, i.e. the reuse of a frequency channel, may be chosen to be 1 (like for 3.84 Mcps TDD) or 3 (since the 1.28 Mcps TDD has one third of the bandwidth of the 3.84 Mcps TDD).

9.2.3 Scenarios

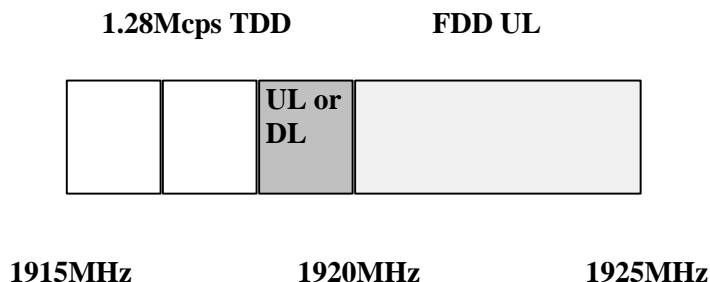

Figure 9.1

The scenarios considered in this document refer to the frequency range about 1920 MHz where TDD and FDD are allocated in adjacent frequency bands.

Since the TDD band may be used for uplink (UL) or downlink (DL) communication 3 different scenarios are of interest depending on which station (MS or BS) is receiving (RX) or transmitting (TX):

- TDD MS (UL TX) causes interference to FDD BS (RX of UL)
- FDD MS (UL TX) causes interference to TDD BS (RX of UL)
- FDD MS (UL TX) causes interference to TDD MS (RX of DL)

The reason for the adjacent channel interference is the non-ideal rise of transmit and receive filter flanks so that a leakage of transmitted power is the adjacent frequency band and a reception from adjacent frequency bands can not entirely be prevented.

To limit this interaction between different frequency bands ACLR (adjacent channel leakage power ratio) requirements for the transmitter and ACS (adjacent channel selectivity) requirements for the receiver are specified (see section before).

In the simulation for the 1.28 Mcps TDD mode spectrum emission masks are used fulfilling the ACLR requirements given in the section before.

Due to the adjacent channel interference superimposing with the co-channel interference contributions received both in the used frequency band it might happen that at the considered receiver station the C/I ratio is below a minimum C/I ratio (see section before) which is necessary for the considered service.

The percentage of these users is called 'outage'.

The used Monte-Carlo based snapshot simulator determines at first for a given outage or noise raise the mean maximum number of mobiles per cell which can be active without adjacent channel interference (single operator case).

Usually an outage of 5% or a noise raise of 6dB (especially for FDD BS as victim, i.e. UL in FDD) is considered for a realistic maximum load of the cell.

Afterwards the mean number of users for the same outage/noise raise (as in the single operator case) is calculated taking into account the co-channel and the additional adjacent interference of the interferer system (multi operator case).

9.3 Methodology for coexistence studies 1.28 Mcps TDD / 3.84 Mcps TDD

9.3.1 Overview of Simulation

Same as subsection 9.2.1

9.3.2 Simulation parameters

This section compares the different simulation parameters for 3.84 Mcps TDD and 1.28 Mcps TDD which are used to describe the ,victim system' and the ,interferer system' in the coexistence simulation scenarios.

Table 9.3: General Parameters

| No. | Parameter | | a. 3.84 Mcps TDD | | b. 1.28 Mcps TDD | |
|-----|-----------------------------------------------|------------------|--------------------------------------------------------------------------|----|-----------------------------------|----|
| | | | MS | BS | MS | BS |
| P1 | Chip rate | Mcps | 3.84 | | 1.28 | |
| P2 | Frame length | ms; chip | 10ms; 38400 | | 10ms; 12800 | |
| P3 | Slot length | ms;chip | 666.666 μ s; 2560 | | 675 μ s; 864 | |
| P4 | Slots per frame | 1 | 15 | | 14 (+ pilots and guard period) | |
| P5 | Chip length | Ms | 260.41666ns | | 781.25ns | |
| P6 | Sfmax | 1 | 16 | | 16 | |
| P7 | Sfmin | 1 | 1 | | 1 | |
| P8 | Size of data symbol alphabet | 1 | 4 (QPSK) | | 4 (QPSK) | |
| P9 | No. of codes per TS | 1 | 12 | | 16 | |
| P10 | No. of codes used for an 8kbps speech service | 1 | UL: 1xSF=16 DL: 1xSF=16 | | UL: 1xSF=16 DL: 1xSF=16 | |
| P11 | User bandwidth | MHz | 3.84 | | 1.28 | |
| P12 | Channel spacing | MHz | 5 | | 1.6 | |
| P13 | Antenna position over ground | M | MS: 1.5m BS: antenna height (15m) + average roof top level (12m) =27m | | | |
| P14 | Considered coverage area | Cell radius in m | Macro: 500m | | | |
| P15 | Considered cluster size | 1 | - | 1 | - | 1 |
| P16 | Minimum coupling loss (MCL) | DB | BS-MS: 70, MS-MS: 35 | | BS-MS: 70, MS-MS: 35 | |

Table 9.4: Receiver Parameters

| No. | Parameter | | a. 3.84 Mcps TDD | | b. 1.28 Mcps TDD | |
|-----|-----------------------------|-----|------------------|------|------------------|------|
| | | | MS | BS | MS | BS |
| RX1 | Sensitivity | DBm | -105 | -109 | -108 | -110 |
| RX2 | Noise figure | DB | 9 | 5 | 9 | 7 |
| RX3 | Antenna gain (incl. losses) | DBi | 0 | 11 | 0 | 11 |
| RX4 | ACS | DB | 33 | 45 | 33 | 45 |
| RX5 | Min. CIR for 8kbps speech | DB | -5.6 | -8.1 | -1.5 | -6.7 |

Table 9.5: Transmitter Parameters

| No. | Parameter | | a. 3.84 Mcps TDD | | b. 1.28 Mcps TDD | |
|-----|--------------------------------------|-----|-------------------|------------------|-------------------|------------------|
| | | | MS | BS | MS | BS |
| TX1 | Max. TX power | DBm | 30 | 43 (36 per user) | 30 | 43 (33 per user) |
| TX2 | Min.Tx power per user | DBm | -44 | 36-30=6 | -44 | 33-30=3 |
| TX3 | Antenna gain | DB | See RX3 | | | |
| TX4 | PC dynamic range (1 code considered) | DB | Max-(-44) = 74 | 30 | Max-(-44) = 74 | 30 |
| TX5 | ACLR | DB | 33 (43) | 45 (50) | 33 (43) | 40 (50) |

As a first step concerning the minimum C/I ratio values of the 1.28 Mcps TDD system for the 8kbps speech service these results for a 12.2kbps service for case 3 were taken:

- UL (i.e. receiving BS): $C/I_{min} = -4.9dB$
- DL (i.e. receiving MS): $C/I_{min} = 0.3dB$.

Considering the mapping of the information data bits for the 12.2kbps service in UL and DL: 244 bits are mapped on 536 bits.

For an 8kbps speech service we assumed in a first approach that:

244 x (8kbps / 12.2kbps) bits are mapped on 536bits

which results in a subtraction of 1.83dB for the both C/I_{min} values mentioned before which finally lead to the values in the table.

For the 3.84 Mcps TDD system the minimum C/I requirements were taken from [8].

The ACLR and ACS values were taken from the specifications 25.102, 25.105 for 3.84 Mcps TDD and the report 25.945 for 1.28 Mcps TDD.

The cluster size of the 1.28 Mcps TDD, i.e. the reuse of a frequency channel, may be chosen to be 1 (like for 3.84 Mcps TDD) or 3 (since the 1.28 Mcps TDD has one third of the bandwidth of the 3.84 Mcps TDD). In our investigations we take cluster=1 as a first approach.

9.3.3 Scenarios

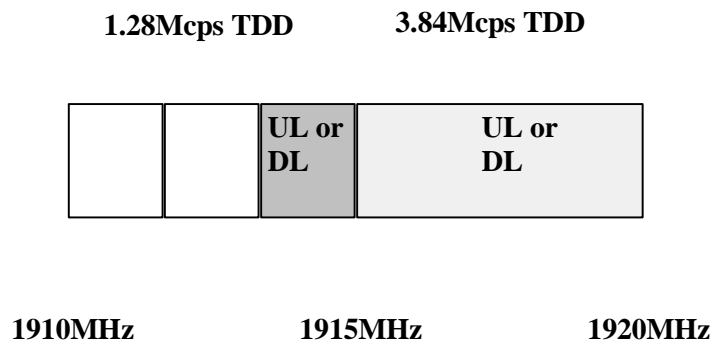

Figure 9.2

The scenarios considered in this section refer to the frequency 1915MHz where 1.28 Mcps TDD and 3.84 Mcps TDD may be allocated in adjacent frequency bands.

In a first step the 1.28 Mcps TDD system is assumed to be a victim for adjacent channel interference of a 3.84 Mcps TDD system.

Since the TDD band may be used for uplink (UL) or downlink (DL) communication 3 different scenarios are of interest depending on which station (MS or BS) is receiving (RX) or transmitting (TX):

- 3.84 Mcps TDD MS (UL TX) causes interference to 1.28 Mcps TDD BS (RX of UL)
- 3.84 Mcps TDD MS (UL TX) causes interference to 1.28 Mcps TDD MS (RX of DL)
- 3.84 Mcps TDD BS (DL TX) causes interference to 1.28 Mcps TDD MS (RX of DL)

In a second step the 3.84 Mcps TDD system is the victim system suffering from adjacent channel interference of the 1.28 Mcps TDD system. Here 3 further cases need to be investigated:

- 1.28 Mcps TDD MS (UL TX) causes interference to 3.84 Mcps TDD BS (RX of UL)
- 1.28 Mcps TDD MS (UL TX) causes interference to 3.84 Mcps TDD MS (RX of DL)
- 1.28 Mcps TDD BS (DL TX) causes interference to 3.84 Mcps TDD MS (RX of DL)

9.4 Methodology for coexistence studies 1.28 Mcps TDD / 1.28 Mcps TDD

9.4.1 Overview of Simulation

Same as subsection 9.2.1

9.4.2 Simulation parameters

Same as subsection 9.3.2

9.4.3 Scenarios

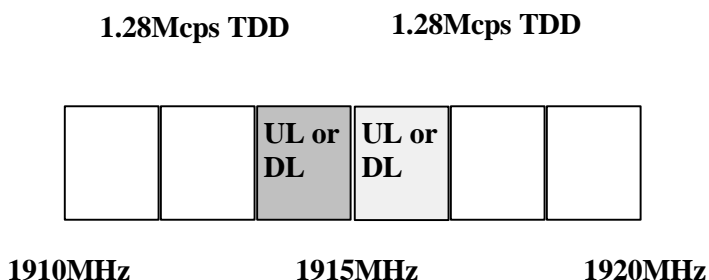

Figure 9.3

In this section a scenario of two 1.28 Mcps TDD operators in the same geographic area is investigated. For both systems apart from the frequency bands the same rf parameters and again no synchronisation or coordination is assumed.

Since the TDD band may be used for uplink (UL) or downlink (DL) communication 3 different scenarios are of interest depending on which station (MS or BS) is receiving (RX) or transmitting (TX):

- 1.28 Mcps TDD MS (UL TX) causes interference to 1.28 Mcps TDD BS (RX of UL)
- 1.28 Mcps TDD MS (UL TX) causes interference to 1.28 Mcps TDD MS (RX of DL)
- 1.28 Mcps TDD BS (DL TX) causes interference to 1.28 Mcps TDD MS (RX of DL)

9.5 Results, implementation issues and recommendations

9.5.1 1.28 Mcps TDD /FDD

9.5.1.1 Simulation results

The results for the relative capacity loss are summarized in the table below.

Table 9.6

| victim (receiver) | interferer (transmitter) | rel. capacity loss |
|------------------------------|------------------------------|--------------------|
| FDD BS | 1.28 Mcps TDD MS (cluster=1) | <2% |
| 1.28 Mcps TDD BS (cluster=1) | FDD MS | <2% |
| 1.28 Mcps TDD MS (cluster=1) | FDD MS | <2% |
| 1.28 Mcps TDD MS (cluster=3) | FDD MS | <3% |

9.5.1.2 Conclusion

The focus of these investigations is on speech users in macro cells for a vehicular propagation environment.

The results show reasonable capacity loss values, even without coordination or time alignment between the victim and the interferer system.

9.5.2 1.28 Mcps TDD / 3.84 Mcps TDD

9.5.2.1 Simulation results

The results for the relative capacity loss are summarized in the tables below.

- 1) For the case that the 1.28 Mcps TDD system suffers from adjacent channel, and interference from a 3.84 Mcps TDD system:

Table 9.7

| Victim (receiver) | interferer (transmitter) | Relative capacity loss |
|------------------------------|--------------------------|------------------------|
| 1.28 Mcps TDD BS (cluster=1) | 3.84 Mcps TDD MS | < 1% |
| 1.28 Mcps TDD MS (cluster=1) | 3.84 Mcps TDD MS | < 2% |
| 1.28 Mcps TDD MS (cluster=1) | 3.84 Mcps TDD BS | < 2% |

- 2) For the case that the 3.84 Mcps TDD system suffers from adjacent channel, and interference from a 1.28 Mcps TDD system:

Table 9.8

| Victim (receiver) | interferer (transmitter) | Relative capacity loss |
|-------------------|------------------------------|------------------------|
| 3.84 Mcps TDD BS | 1.28 Mcps TDD MS (cluster=1) | <2% |
| 3.84 Mcps TDD MS | 1.28 Mcps TDD MS (cluster=1) | < 1% |
| 3.84 Mcps TDD MS | 1.28 Mcps TDD BS (cluster=1) | < 2% |

9.5.2.2 Conclusion

The focus of these investigations is on speech users in macro cells for a vehicular propagation environment.

The results show reasonable capacity loss values, even without coordination or time alignment between the victim and the interferer system.

9.5.3 1.28 Mcps TDD / 1.28 Mcps TDD

9.5.3.1 Simulation results

The results for the relative capacity loss are summarized in the table below.

Table 9.9

| Victim (receiver) | interferer (transmitter) | relative capacity loss |
|-----------------------------------------------|-----------------------------------------------|------------------------|
| 1.28 Mcps TDD BS of operator A (cluster=1) | 1.28 Mcps TDD MS of operator B (cluster=1) | < 2% |
| 1.28 Mcps TDD MS of operator A (cluster=1) | 1.28 Mcps TDD MS of operator B (cluster=1) | < 2% |
| 1.28 Mcps TDD MS of operator A (cluster=1) | 1.28 Mcps TDD BS of operator B (cluster=1) | < 1% |

9.5.3.2 Conclusion

The focus of these investigations is on speech users in macro cells for a vehicular propagation environment.

The results show reasonable capacity loss values, even without coordination or time alignment between the victim and the interferer system.

9.6 Information and General purpose materials

9.6.1 CDMA Definitions and Equations

9.6.1.1 CDMA-related definitions

The following CDMA-related abbreviations and definitions are used in various 3GPP WG4 documents.

Table 9.10

| | |
|-----------------------------|----------------------------------------------------------------------------------------------------------------------------------|
| Chip Rate | 1.28M chips per second. |
| $DwPTS_E_c$ | Average energy per PN chip for DwPTS. |
| $DwPTS \frac{E_c}{I_o}$ | The ratio of the received energy per PN chip for DwPTS to the total received power spectral density at the UE antenna connector. |
| $\frac{DwPTS_E_c}{I_{or}}$ | The ratio of the average transmit energy per PN chip for DwPTS to the total transmit power spectral density. |

9.6.1.1.1 Explanation difference

For 1.28 Mcps chip rate TDD option, the frame length is 10ms and the 10ms is divided into 2 sub-frames of 5 ms. Each subframe is composed of 7 normal traffic time slots and two special pilot slots, i.e., DwPTS for downlink and UpPTS for uplink.

For 1.28 Mcps chip rate TDD option, the other CDMA related definitions have the same meaning as for 3.84 Mcps TDD.

9.6.1.2 CDMA equations

The equations listed below describe the relationship between various parameters under different conditions.

9.6.1.2.1 BS Transmission Power

Transmit power of the Base Station is normalized to 1 and can be presented as

$$\frac{\sum_{i=1}^n DPCH_i - E_c}{I_{or}} + \frac{\sum_{j=1}^m DPCH_{0j} - E_c}{I_{or}} = 1 \quad \text{(Normal downlink timeslots)}$$

$$\frac{PCCPCH - E_c}{I_{or}} = 1 \quad \text{(Timeslot 0)}$$

$$\frac{DwPTS - E_c}{I_{or}} = 1 \quad \text{(DwPTS)}$$

9.6.1.2.1.1 Explanations

1.28 Mcps TDD option has special frame structure; its TS0 is only used for downlink so the position of P-CCPCH is fixed. DwPTS and UpPTS are unique slots so separate equations are need for them.

9.7 Link Level performances

9.7.1 Simulation results for 1.28 Mcps TDD performance

9.7.1.1 Simulation assumptions

9.7.1.1.1 Simulation chain

9.7.1.1.1.1 Downlink

Because joint detection is considered for the low chip rate TDD option, the simulation has to differ from the wideband TDD simulation. An orthogonal channel noise simulator (OCNS) can not be used, instead all intracell interferer have to be modelled individually. The simulation chain is shown in the figure below.

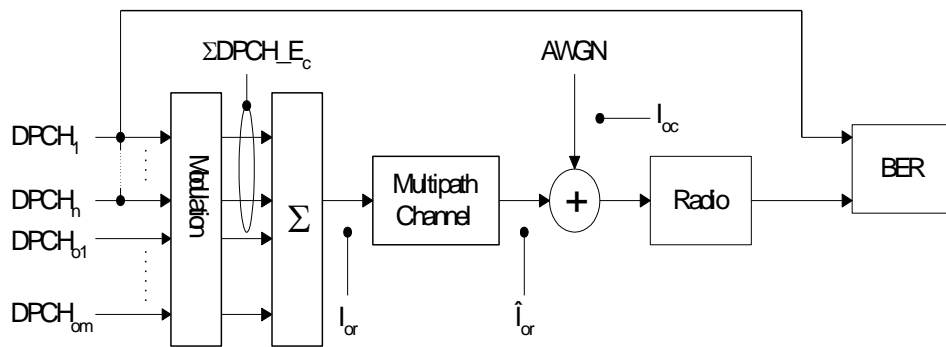

Figure 9.4: Downlink simulation chain

I_{oc} represents the intercell interference and other noise contributions, and $DPCH_{0i}$ for $i=1$ to m are the individual intracell interferer. Each intracell interferer $DPCH_{0i}$ is modelled by one code with $Q=16$. $DPCH_1$ to $DPCH_n$ are the DPCH for the service under investigation. All $DPCH_i$ for $i=1$ to n and $DPCH_{0j}$ for $j=1$ to m have the same chip energy $DPCH - E_c$. Note that in the downlink all codes have a spreading factor of 16 for all reference measurement channels.

The ratio of \hat{I}_{or} to I_{oc} is varied until the BLER target is reached, and

$$\Sigma DPCH - E_c = n \cdot DPCH - E_c .$$

For the performance requirement test, the ratio of \hat{I}_{or} to I_{oc} is increased by the implementation margin.

9.7.1.1.1.2 Uplink

In the uplink the same simulation chain as for wide-band TDD is used. The uplink simulation chain is shown in figure 9.5.

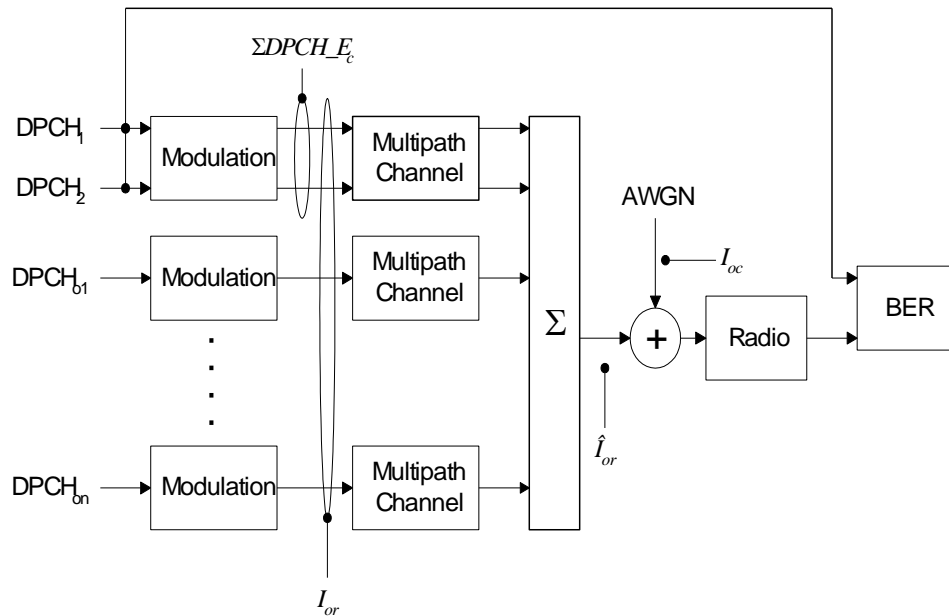

Figure 9.5: Uplink simulation chain

DPCH₁ and DPCH₂ are the DPCH for the service under investigation. DPCH_{oi} for $i=1$ to n is one code with the spreading factor 8. The ratio of \hat{I}_{or} to I_{oc} is varied until the BLER target is reached.

For the reference measurement channel one or two codes with different spreading factors are used. The following equations apply for the chip energy:

$$\frac{DPCH_1 - E_c}{DPCH_2 - E_c} = \frac{Q_2}{Q_1}$$

and

$$\frac{DPCH_{oi} - E_c}{\Sigma DPCH - E_c} = \frac{Q_1 Q_2}{(Q_1 + Q_2) \cdot 8},$$

where Q_1 and Q_2 refer to the spreading factors of DPCH₁ and DPCH₂ and

$$\Sigma DPCH - E_c = DPCH_1 - E_c + DPCH_2 - E_c.$$

If only a single code is used for the service under investigation, $DPCH_2 - E_c$ is null. In this case the following formula applies:

$$\frac{DPCH_1 - E_c}{DPCH_{oi} - E_c} = \frac{8}{Q_1}$$

The implementation margin is encountered in the intercell interference ratio \hat{I}_{or}/I_{oc} .

9.7.1.1.2 Simulation Assumptions

9.7.1.1.2.1 General

Table 9.11

| Parameter | Explanation/Assumption |
|------------------------------------|-----------------------------------------------------------------------------------------------------------------------------|
| Chip Rate | 1.28 Mcps |
| Duration of TDMA sub-frame | 5 ms |
| Number of time slots per sub-frame | 7 |
| Closed loop power control | OFF |
| AGC | OFF |
| Number of samples per chip | 1 sample per chip |
| Propagation Conditions | See Tdoc R400TDD051 |
| Numerical precision | Floating point simulations |
| BLER target | 10E-1; 10E-2; 10E-3 |
| BLER calculation | BLER will be calculated by comparing with transmitted and received bits. |
| DCCH model | Random symbols transmitted, not evaluated in the receiver |
| TPC and SS model | Random symbols transmitted, not evaluated in the receiver |
| TFCI model | Random symbols, not evaluated in the receiver but it is assumed that receiver gets error free reception of TFCI information |
| Turbo decoding | Max Log Map with 4 iterations |
| Measurement Channels | See Tdoc R400TDD052 |
| Other L1 parameters | As Specified in latest L1 specifications |
| Cell parameter | 0 (this determines the scrambling and basic midamble code) |

9.7.1.1.2.2 Additional downlink parameters

Table 9.12

| Parameter | Value | | | | |
|--------------------------------------------------------------------|-------------------------------------------------------------------------------------------------------------------------------------------------------------------------------------------------------------------|------------|------------|------------|----------|
| I_{or}/I_{oc} | Ratio to meet the required BLER target | | | | |
| # of DPCH _{oi} | Bit rate | Static | Case 1 | Case 2 | Case 3 |
| | 12.2 kbps | 8 | 8 | 8 | 8 |
| | 64 kbps | 2 | 2 | 2 | 2 |
| | 144 kbps | 2 | 2 | 2 | 2 |
| | 384 kbps | 0 | 0 | 0 | 0 |
| Number of timeslots per sub-frame per user | 12.2 kbps: TS=1 64 kbps: TS=1 144 kbps: TS=2 384 kbps: TS=4 | | | | |
| Transmit diversity, "TxAA", "TSTD" | OFF | | | | |
| Receiver antenna diversity | OFF | | | | |
| Midamble | Common midamble (See TR25.928v1.1.0 chapter 7.2.5) | | | | |
| Channelisation codes C(k; Q) (see TR25.928v1.1.0 chapter 9.2.2) | | 12.2 kbps | 64 kbps | 144 kbps | 384 kbps |
| | DPCH _i | C(i; 16) | C(i; 16) | C(i; 16) | C(i; 16) |
| | DPCH _{oj} | C(j+2; 16) | C(j+8; 16) | C(j+8; 16) | - |
| Receiver | Joint Detector (ZF-BLE) | | | | |
| Channel Estimation | Ideal multipath delay estimation and joint channel estimator according to article from Steiner and Baier in Freq., vol. 47, 1993, pp.292-298, based on correlation to obtain the complex amplitudes for the path. | | | | |

9.7.1.1.2.3 Additional uplink parameters

Table 9.13

| Parameter | Value | | | | |
|--------------------------------------------------------------------|-------------------------------------------------------------------------------------------------------------------------------------------------------------------------------------------------------------------|-----------|-----------|-----------|----------|
| Channel Estimation | Ideal multipath delay estimation and joint channel estimator according to article from Steiner and Baier in Freq., vol. 47, 1993, pp.292-298, based on correlation to obtain the complex amplitudes for the path. | | | | |
| Receiver antenna diversity | ON (2 antennas) | | | | |
| I_{or}/I_{oc} [dB] | Parameter to meet the required BLER | | | | |
| # of DPCH _{oi} | Bit rate | Static | Case 1 | Case 2 | Case 3 |
| | 12.2 kbps | 4 | 4 | 4 | 4 |
| | 64 kbps | 1 | 1 | 1 | 1 |
| | 144 kbps | 1 | 1 | 1 | 1 |
| Number of timeslots per frame per user | 12.2 kbps | TS=1 | | | |
| | 64 kbps | TS=1 | | | |
| | 144 kbps | TS=2 | | | |
| | 384 kbps | TS=4 | | | |
| Channelisation codes C(k; Q) (see TR25.928v1.1.0 chapter 9.2.2) | | 12.2 kbps | 64 kbps | 144 kbps | 384 kbps |
| | DPCH ₁ | C(1; 8) | C(1; 2) | C(1; 2) | C(1; 2) |
| | DPCH ₂ | - | - | - | C(5; 8) |
| | DPCH _{oi} | C(i+1; 8) | C(i+4; 8) | C(i+4; 8) | - |
| Midamble | UE specific (See TR25.928v1.1.0 chapter 7.2.5) | | | | |
| Receiver | Multi-User Detection (ZF-BLE) | | | | |

9.7.1.2 Simulation results

9.7.1.2.1 12.2kbps service

9.7.1.2.1.1 Graphical Presentation of 12.2 kbps service UL Simulation Results

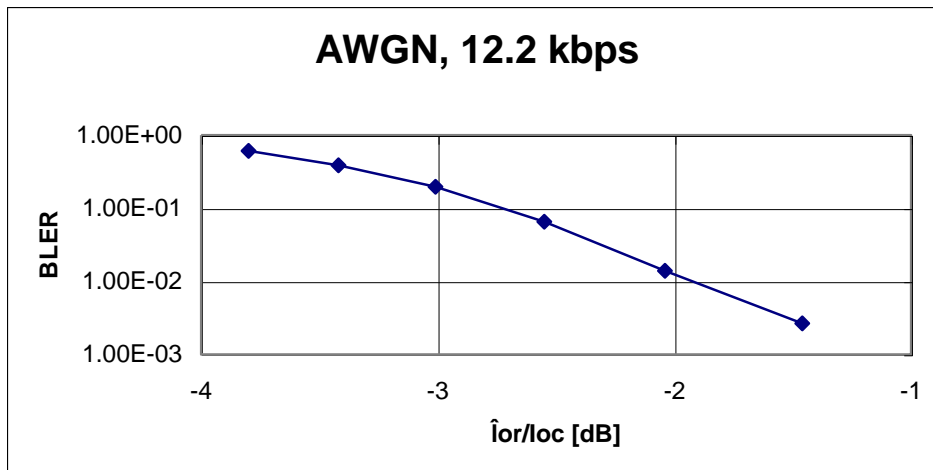

Figure 9.6

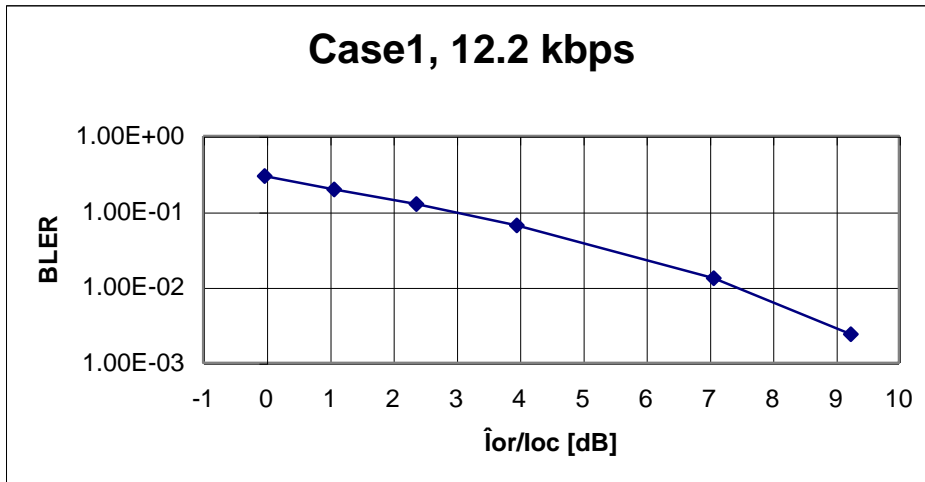

Figure 9.7

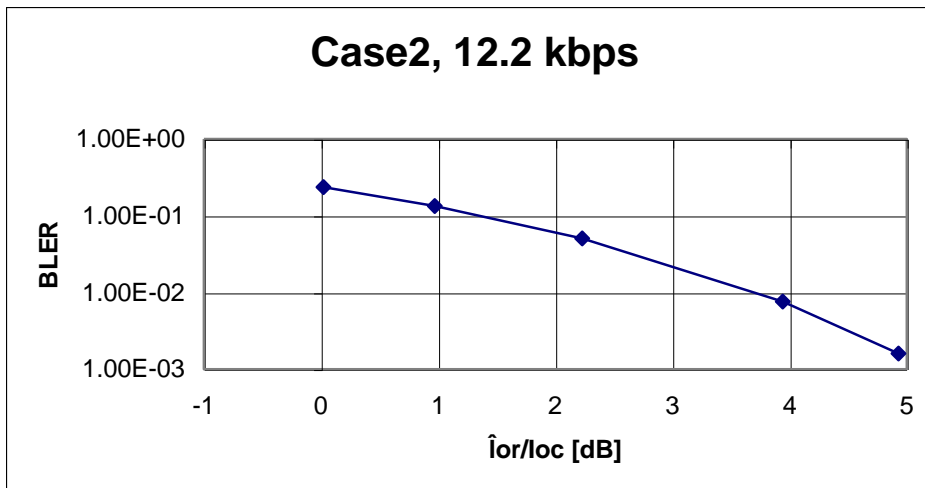

Figure 9.8

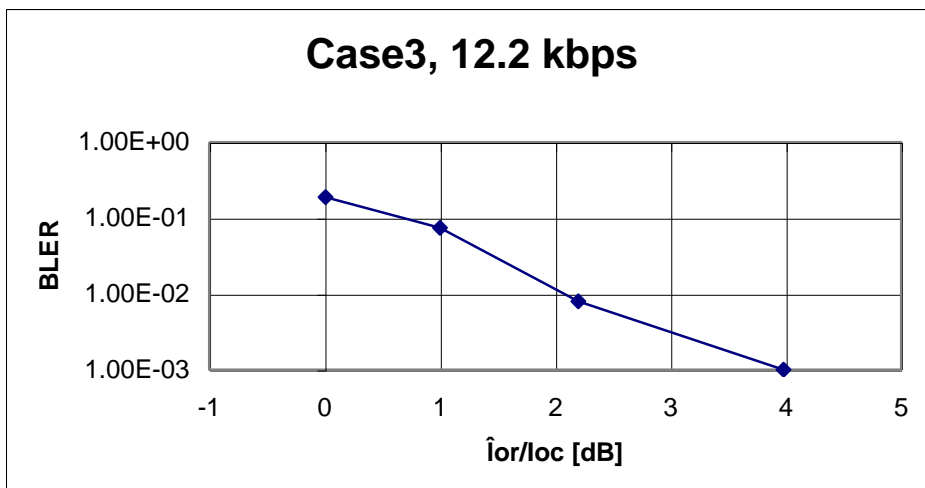

Figure 9.9

9.7.1.2.1.2

Graphical Presentation of 12.2 kbps service DL Simulation Results

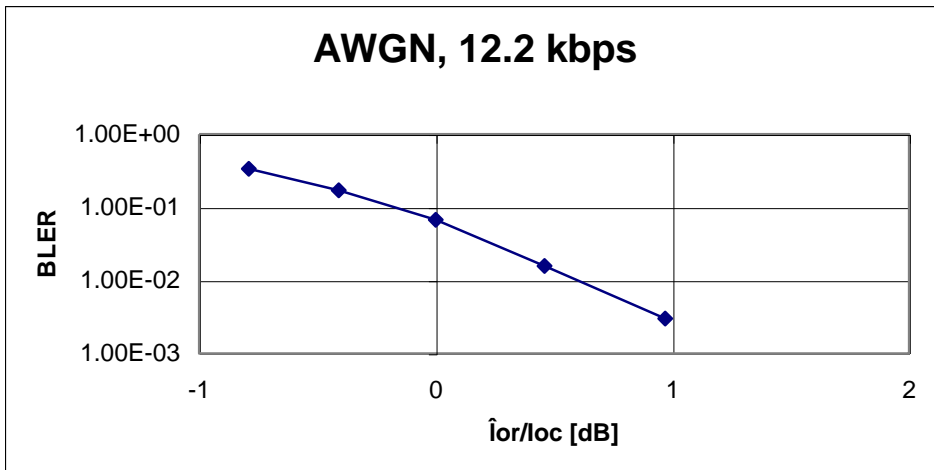

Figure 9.10

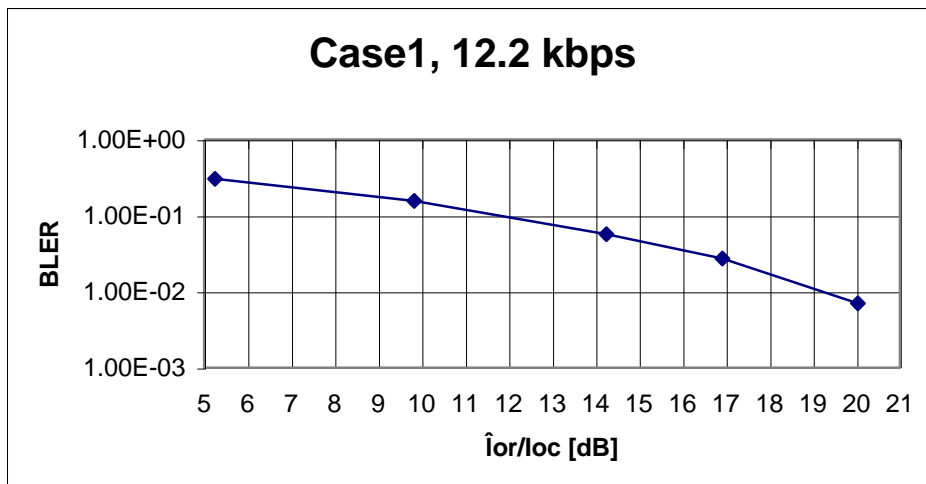

Figure 9.11

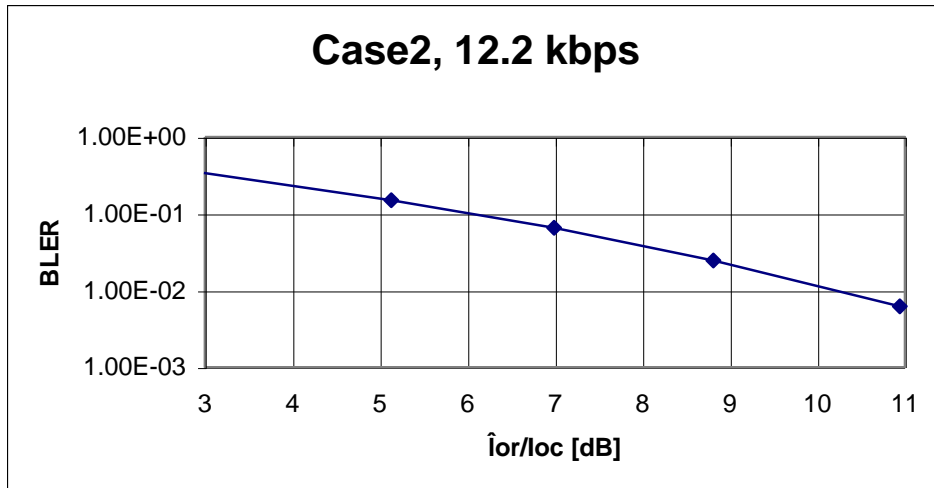

Figure 9.12

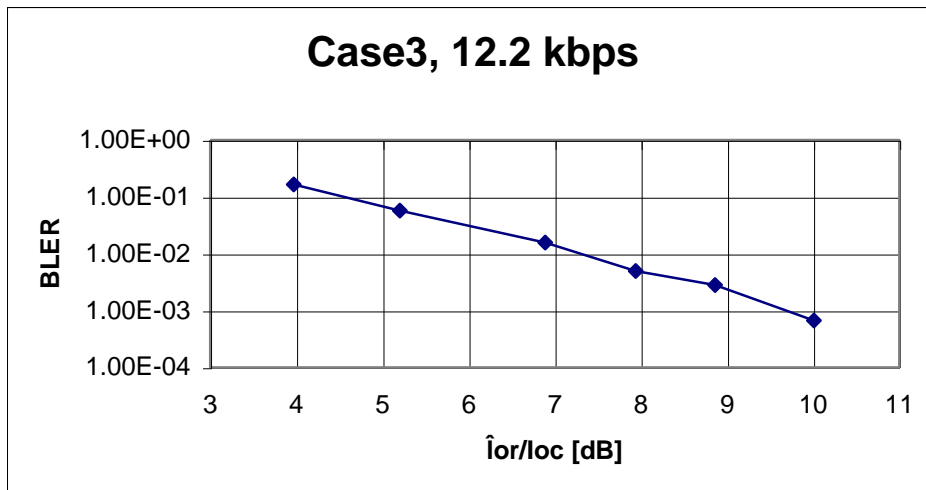

Figure 9.13

9.7.1.2.2 64kps Service

9.7.1.2.2.1 Graphical Presentation of 64 kbps service UL Simulation Results



Figure 9.14

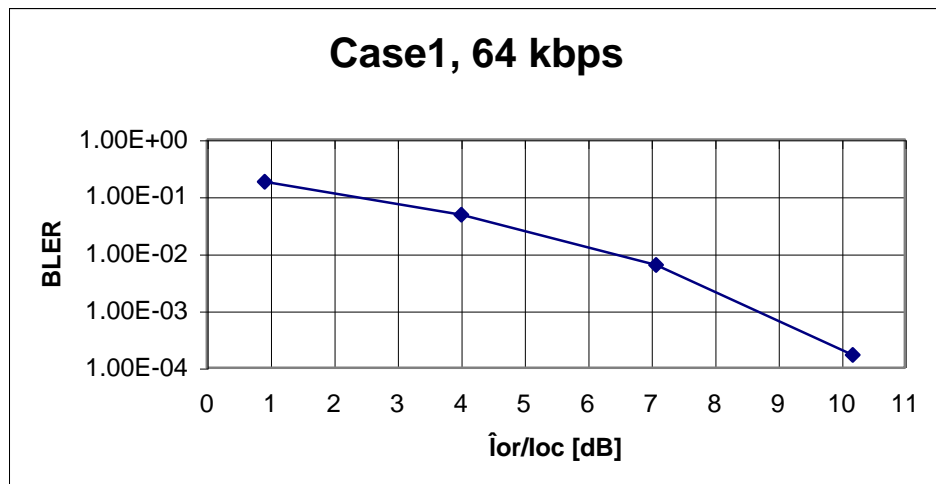

Figure 9.15

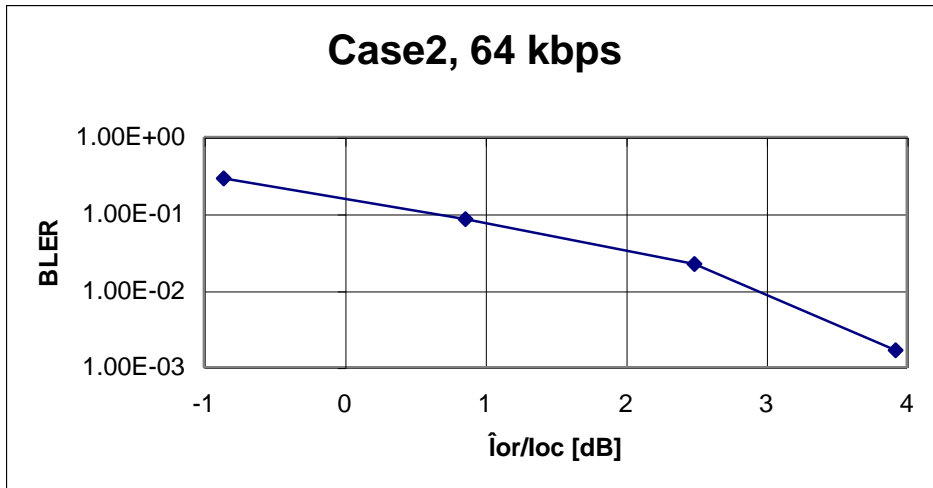

Figure 9.16

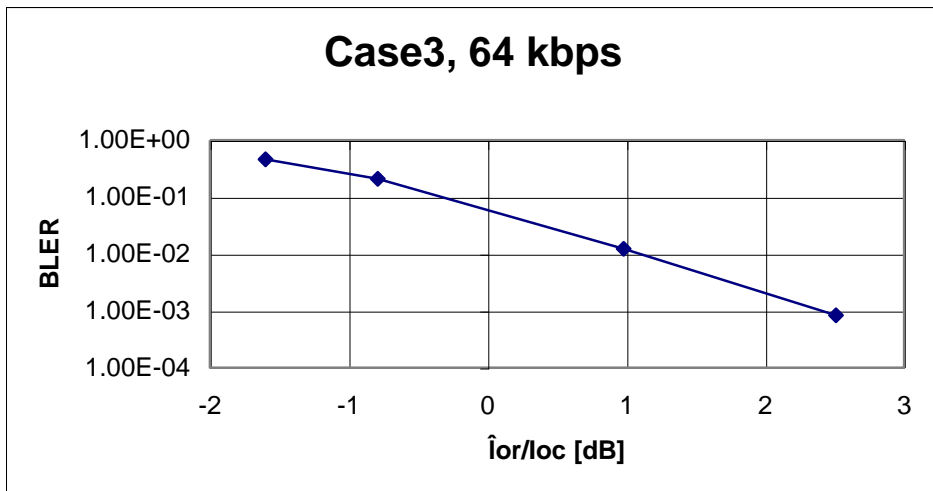

Figure 9.17

9.7.1.2.2.2

Graphical Presentation of 64 kbps service DL Simulation Results



Figure 9.18

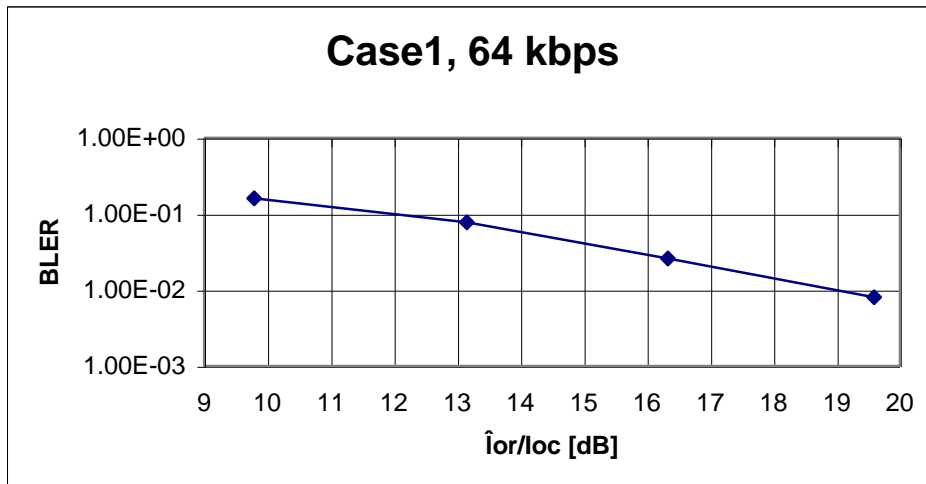

Figure 9.19

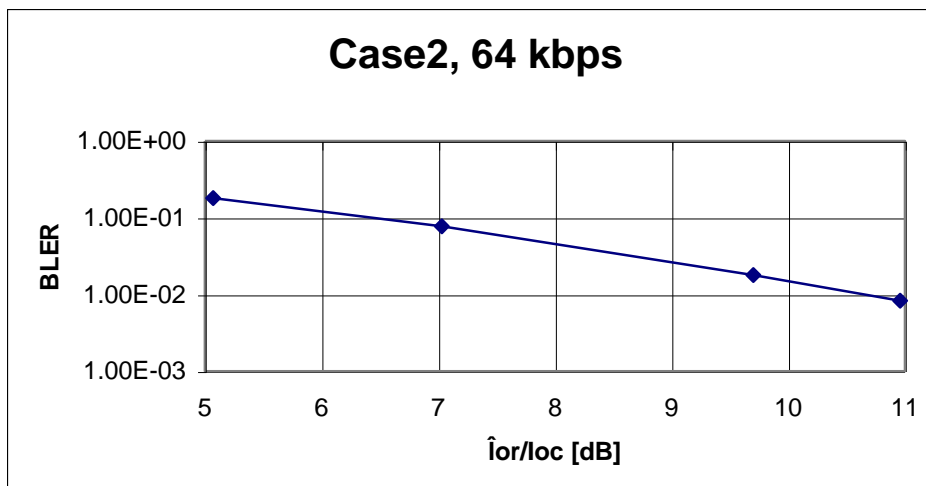

Figure 9.20

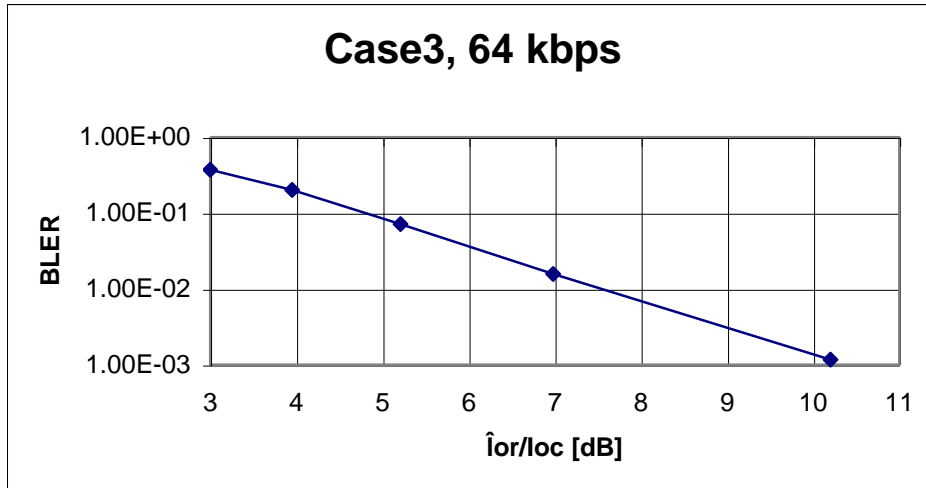

Figure 9.21

9.7.1.2.3 144kps Service

9.7.1.2.3.1 Graphical Presentation of 144 kbps service UL Simulation Results

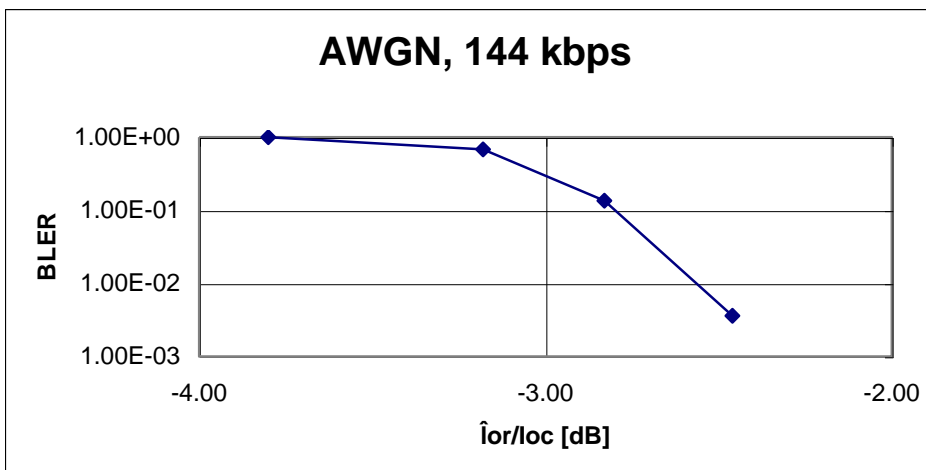

Figure 9.22

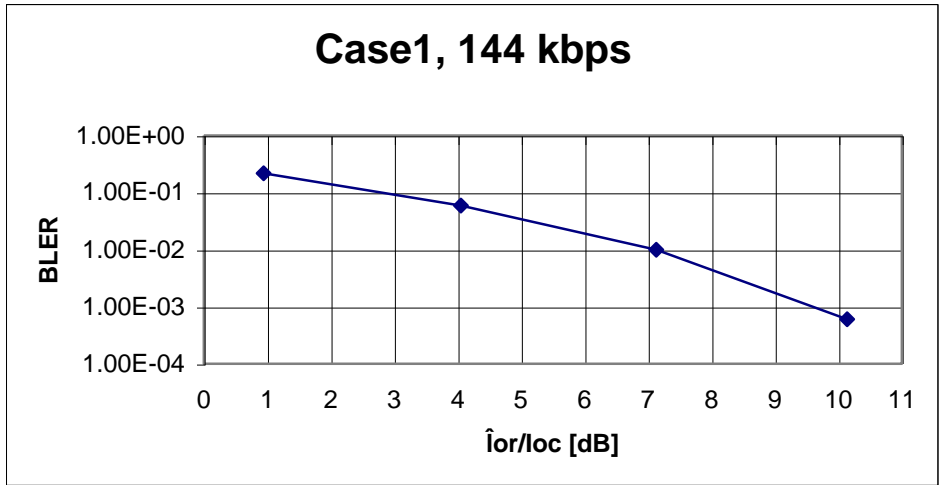

Figure 9.23

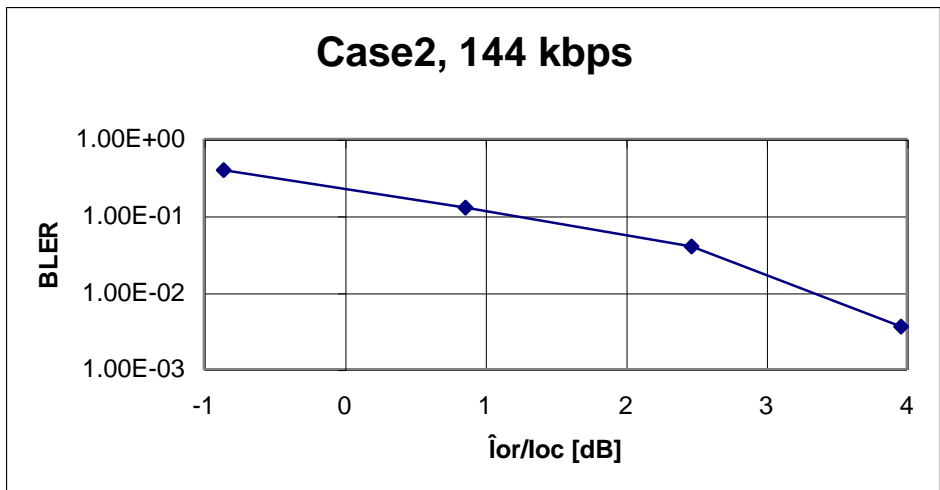

Figure 9.24

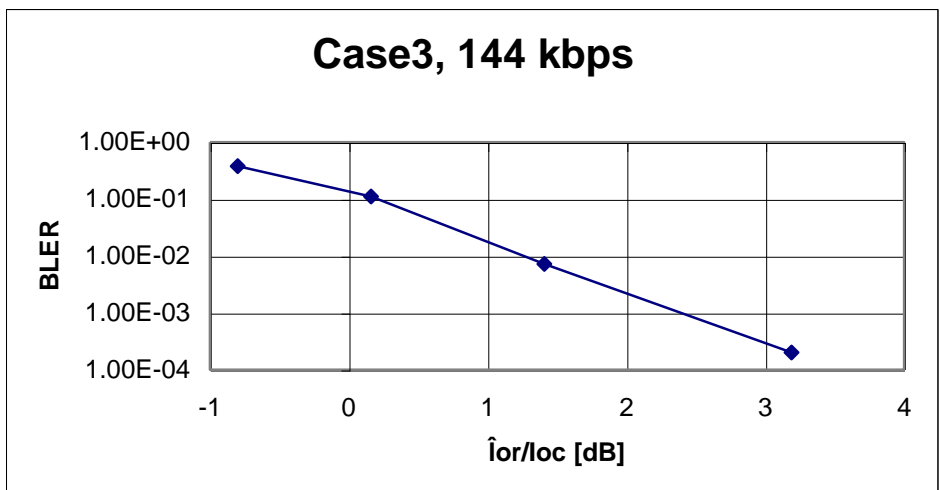

Figure 9.25

9.7.1.2.3.2

Graphical Presentation of 144 kbps service DL Simulation Results

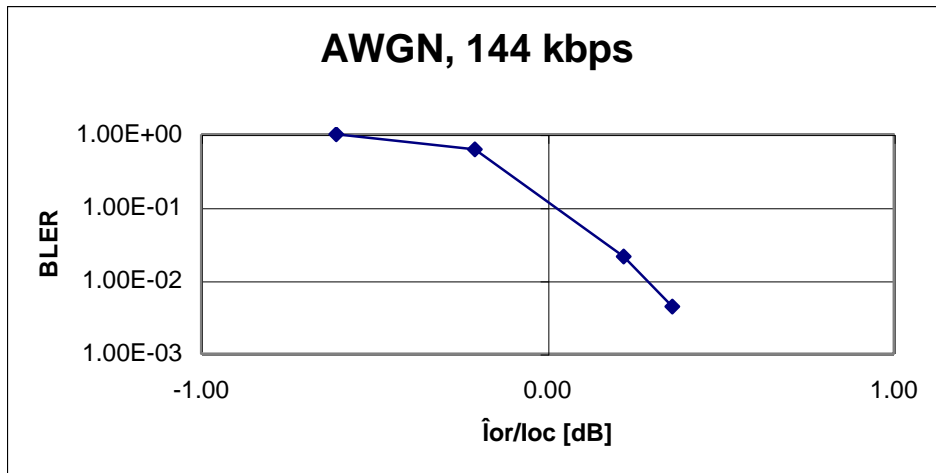

Figure 9.26

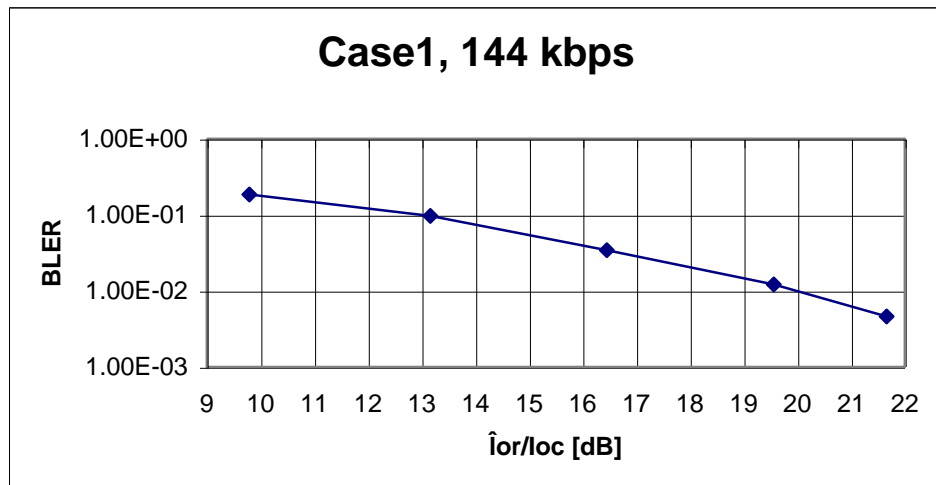

Figure 9.27

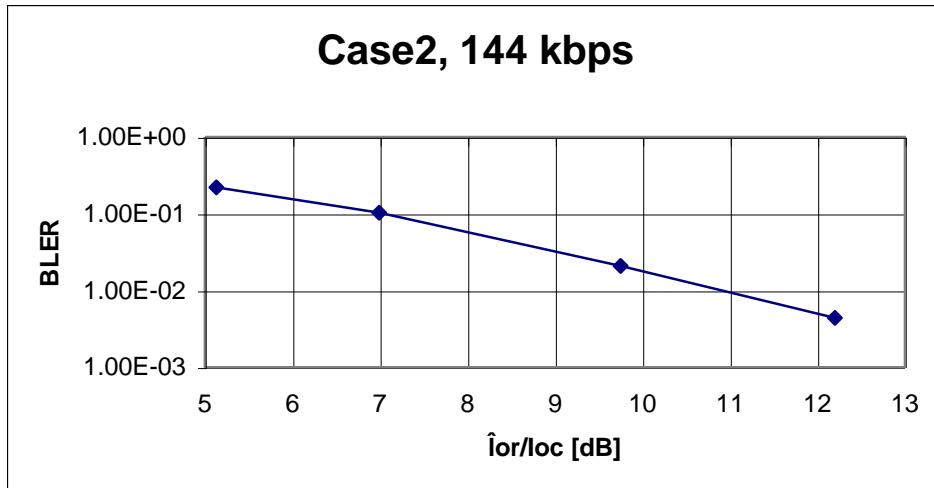

Figure 9.28

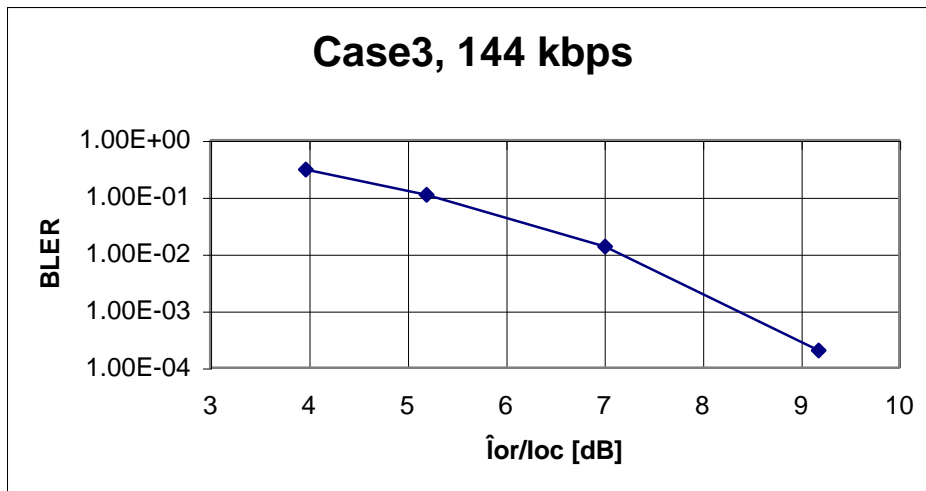

Figure 9.29

9.7.1.2.4 384kps Service

9.7.1.2.4.1 Graphical Presentation of 384 kbps service UL Simulation Results

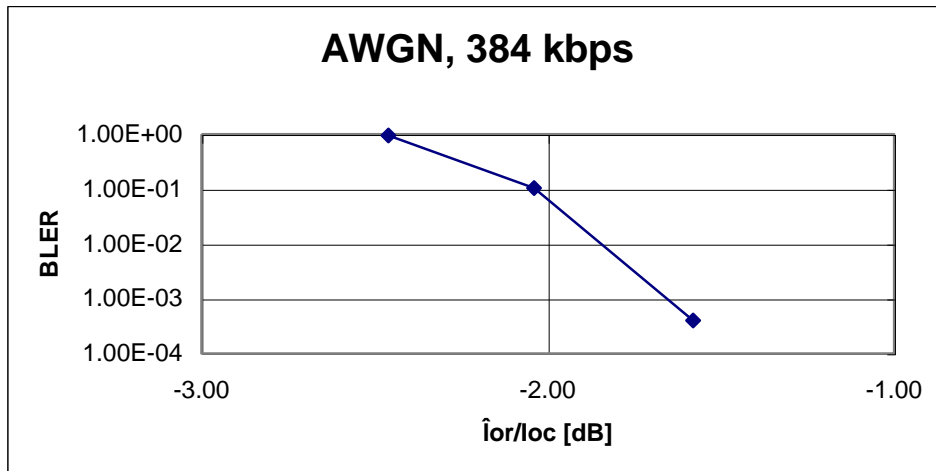

Figure 9.30

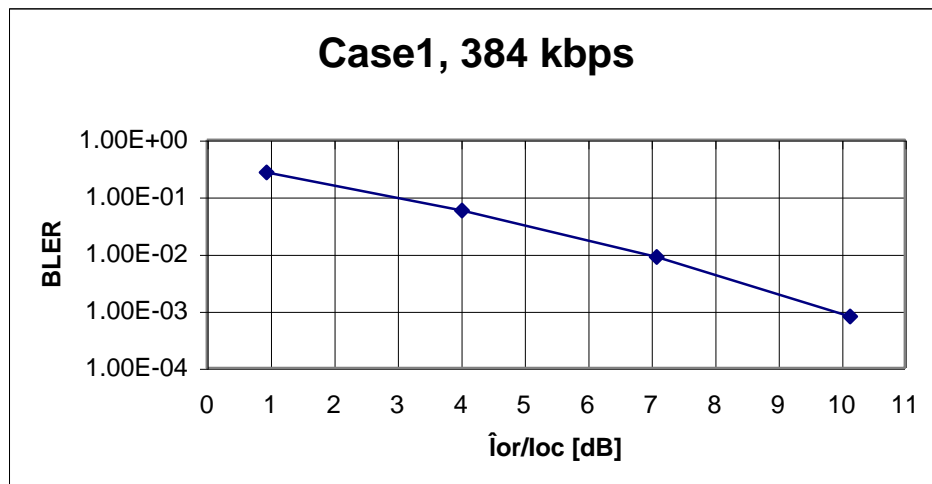

Figure 9.31

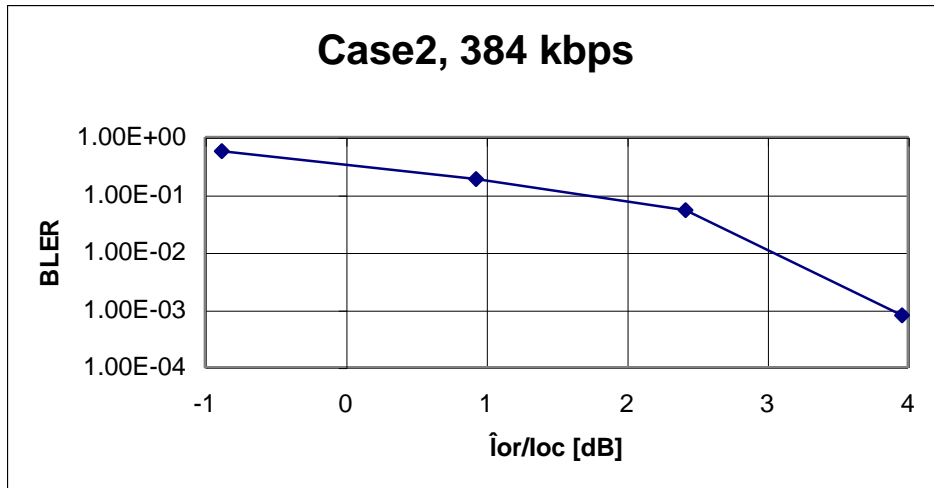

Figure 9.32

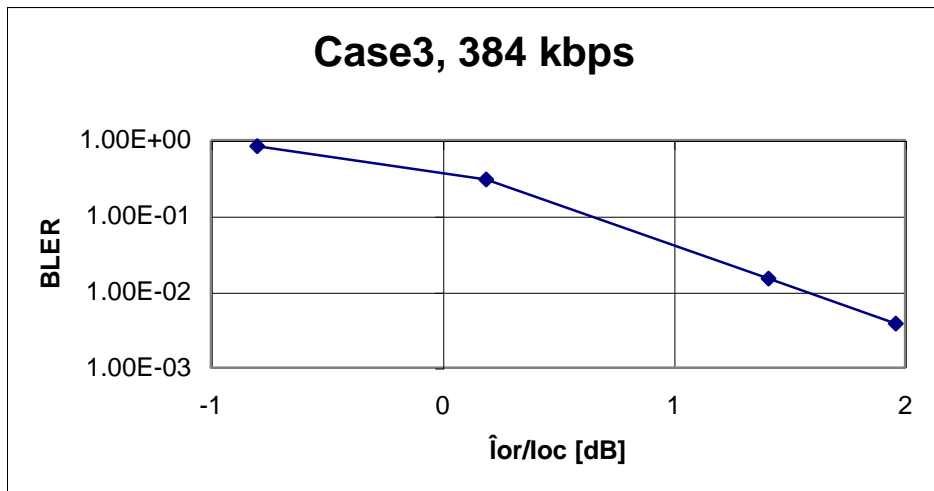

Figure 9.33

9.7.1.2.4.2

Graphical Presentation of 384 kbps service DL Simulation Results

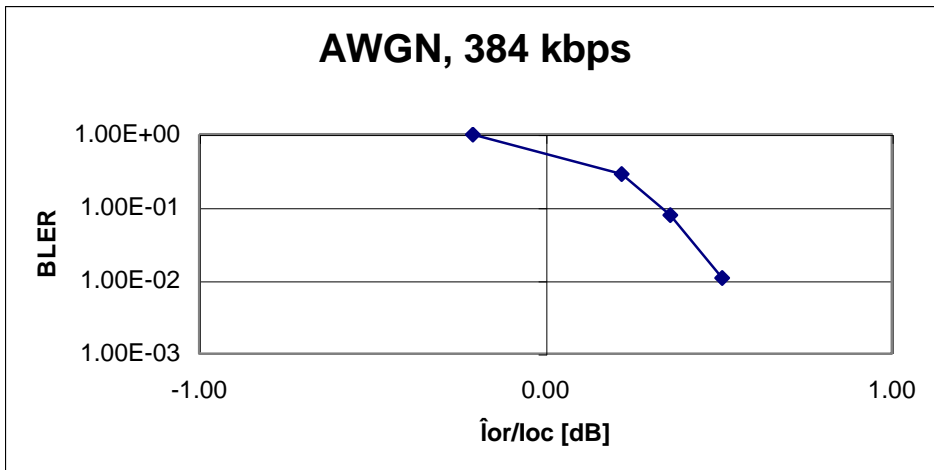

Figure 9.34

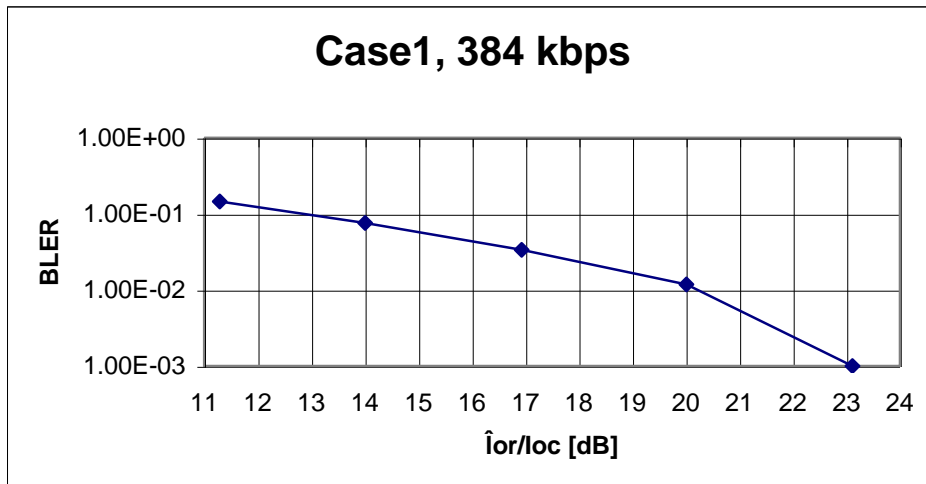

Figure 9.35

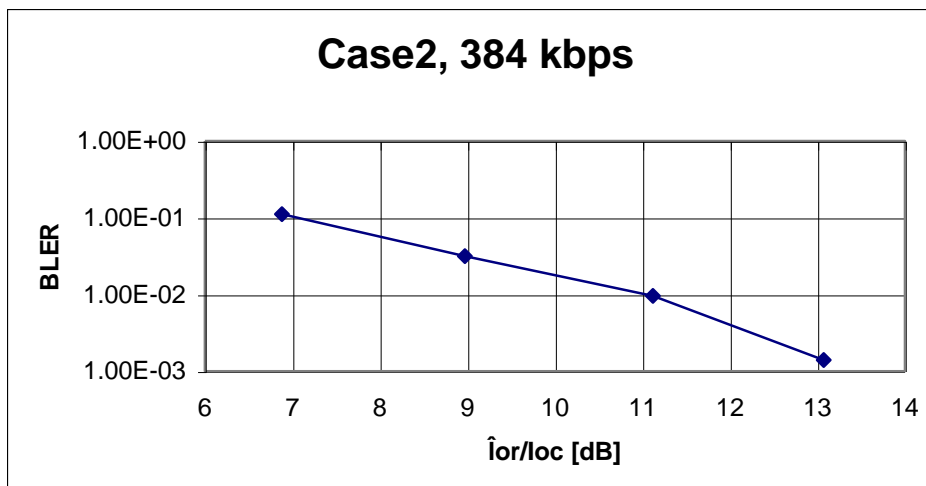

Figure 9.36

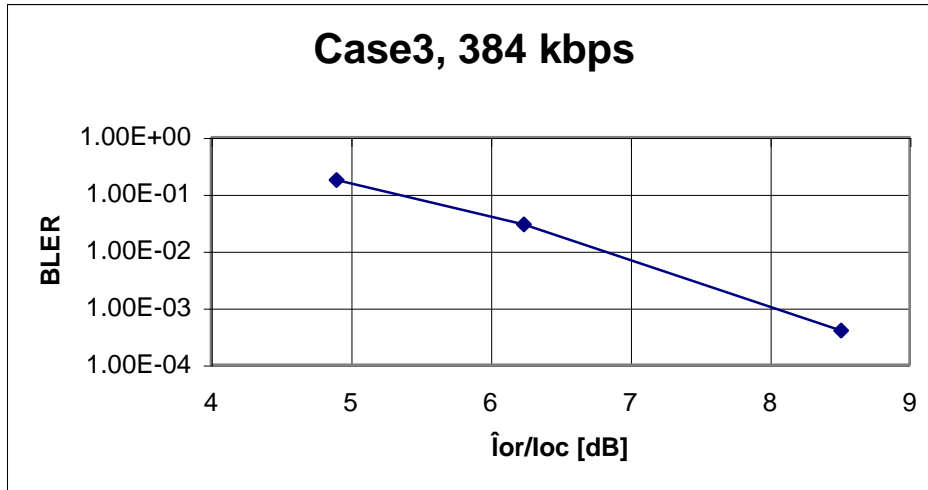

Figure 9.37

9.7.2 1.28 Mcps TDD and FDD link level simulation

(void)

Annex A (informative): The key physical layer parameters for low chip rate TDD option

Table A.1

| Support of : | Difference to high chiprate TDD option | Further details |
|--------------------------------------------|---------------------------------------------------------------------------------------------------------------------------------------------------------------------------------------------------------------------------------------------------------------------------------------------------------------------------------------------------------------------------------------------------------------------------------------------------------------------------------------------------------------------------------------------------------------------------------------------------------------------------------------------------------------------------------------------------------------------------------------------------|------------------------------------------------------------------------------------------------------------------------------------------------------------------------------------------------------------------------------------------------------------------------------------------------------------------------------------------------------------------------------------------------------------------------------------------------------------------------------------------------------------------------------------------------------------------------------------------------------|
| Support of different radio frame structure | <ol style="list-style-type: none"> 1. Different frame structure to high chiprate TDD option 2. Different basic midamble sequences, maximum channel impulse response is scalable ($W=8, 9, 12, 16, 21, 32, 64$), depending on number of users and environment, including the association between midambles and channelisation codes 3. Use of only one burst type for physical channels except special bursts in DwPTS/UpPTS 4. Support of different timeslot formats due to different number of bits and L1 control signals and midamble length 5. Support of use of 8PSK for special timeslots/all timeslots per cell 6. Beacon function is provided by DwPTS and P-CCPCH | <p>Segmentation of the radio frame into 2 subframes Each subframe consists of 7 traffic slots (864 chips length) and two special timeslots for synchronisation and initial access which are separated by an extra guard period</p> <p>5. Including TFCI, SS, and TPC coding (8PSK)</p> |
| Modified Power Control | <ol style="list-style-type: none"> 1. Closed Loop PC in uplink and downlink 2. Open loop PC on the SYNC1 Code while initial access 3. P-CCPCH and DwPTS power can be used as a beacon 4. number of TPC symbols can take 2 values | <ol style="list-style-type: none"> 1. TPC bits also in downlink 3. transmit power level reported on BCH 4. none, one symbol, 16/SF TPC symbols per radio frame, number of TPC symbols is always the same like number of SS symbols |
| Modified RACH procedure | <ol style="list-style-type: none"> 1. Random Access carried out in 2 steps | <ol style="list-style-type: none"> 1. Send SYNC1, Receive FPACH 2. Send power controlled, timing advanced PRACH in traffic timeslot (code associated to received FPACH. There is another association between the PRACH and the FACH. These associations are broadcast by the BCH.) Due to the two-step approach a collision most likely happens on the UpPTS. The RACH RUs are virtually collision free. There are no dedicated RACH time slots, the RACH resources share the time slot with dedicated resources, a two step procedure ensures that the actual RACH. |
| Cell search | <ol style="list-style-type: none"> 1. One synchronisation channel only (DwPTS) and | <ol style="list-style-type: none"> Step 1: Search for DwPTS |

| | | |
|----------------------------------------------------|--------------------------------------------------------------------------------------------------------------------------------------------------------------------------------------------------------------------|----------------------------------------------------------------------------------------------------------------------------------------------------------------------------------------------------------------------------------------------------------------|
| operation | different frame duration | Step 2: Scrambling- and basic midamble code identification Step 3: searches for the head of multi-frame indicated Step 4: Read the BCH |
| Uplink synchronisation | 1.Special Layer1-SS symbols 2.Number of used SS symbols can take 2 values 3.SS-symbols are transmitted once per subframe | 1.SS symbols command an incremental change of timing 2.none, one symbol, 16/SF SS symbols per radio frame, number of SS symbols is always the same like number of TPC symbols 3.Frequency and step size are configured by UTRAN ("k" and "M" parameters) |
| Beamforming | Beamforming applies to the dedicated channels and may also be used for some common channels like FPACH | |
| Physical channels | P-CCPCH and S-CCPCH require two channelisation codes; FPACH is a new physical channel which always uses one channelisation code at SF 16. | |
| Mapping of transport channels to physical channels | PCH; PICH and FACH can be time multiplexed with the BCH on the P-CCPCH. PCH, PICH and FACH can be time multiplexed on the S-CCPCH. Therefore these transport channels are using two channelisation codes of SF 16. | The PICH carries a different number of PIs than in the high chip rate option, because of the different burst structure. |
| Measurements | Ranges and accuracy have to be adapted for the low chip rate option. | |
| Service mapping | Due to the different payload size and subframe segmentation the service mapping for the low chip rate differs from that of the high chip rate option. | |

Annex B (informative): Test Cases

B.a Purpose of Annex

Same contents as TS 25.123 section A.1.

B.b Requirement classification for statistical testing

Same contents as TS 25.123 section A.2.

B.b.1 Types of requirements in TS 25.123

Same contents as TS 25.123 section A.2.1.

B.1 Idle Mode

B.1.1 Cell selection

This section is included for consistency in the numbering.

B.1.2 Cell Re-Selection

For each of the re-selection scenarios in section 4.2 a test is proposed.

For NTDD/NTDD re-selection two scenarios are considered:

Scenario 1: Single carrier case

Scenario 2: Multi carrier case

B.1.2.1 Single carrier case NTDD/NTDD cell re-selection

B.1.2.1.1 Test Purpose and Environment

This test is to verify the requirement for the cell re-selection delay in the single carrier case reported in section 4.2.

This scenario implies the presence of 1 carrier and 6 cells as given in Table B.1 and B.2. Cell 1 and cell2 shall belong to different Location Areas.

Table B.1: General test parameters for Single carrier NTDD/NTDD cell re-selection

| Parameter | | Unit | Value | Comment |
|-----------------------------------------------------|-----------------|------|-----------------------------------|-----------------------------------------------------------------------------------------------------------------------------------|
| Initial condition | Active cell | | Cell1 | |
| | Neighbour cells | | Cell2, Cell3, Cell4, Cell5, Cell6 | |
| Final condition | Active cell | | Cell2 | |
| Access Service Class (ASC#0) - Persistence value | | 0..1 | 1 | Selected so that no additional delay is caused by the random access procedure. The value shall be used for all cells in the test. |
| DRX cycle length | | s | 1.28 | The value shall be used for all cells in the test. |
| T1 | | s | 15 | |
| T2 | | s | 15 | |

Table B.2: Cell re-selection single carrier multi-cell case

| Parameter | Unit | Cell 1 | | | | Cell 2 | | | | Cell 3 | | | |
|------------------------|------|-----------|-------|----------|------|-----------|-------|----------|------|-----------|-------|----------|------|
| Timeslot Number | | 0 | | DWPTS | | 0 | | DWPTS | | 0 | | DWPTS | |
| | | T1 | T2 | T1 | T2 | T1 | T2 | T1 | T2 | T1 | T2 | T1 | T2 |
| UTRA RF Channel Number | | Channel 1 | | | | Channel 1 | | | | Channel 1 | | | |
| PCCPCH_Ec/lor | dB | -3 | -3 | | | -3 | -3 | | | -3 | -3 | | |
| DwPCH_Ec/lor | dB | | | 0 | 0 | | | 0 | 0 | | | 0 | 0 |
| \hat{I}_{or}/I_{oc} | dB | [9] | [7] | [9] | [7] | [7] | [9] | [7] | [9] | [-1] | [-1] | [-1] | [-1] |
| PCCPCH RSCP | dBm | [-64] | [-66] | | | [-66] | [-64] | | | [-74] | [-74] | | |
| Qoffset | | [0] | | [0] | | [0] | | [0] | | [0] | | [0] | |
| Qhyst | | [0] | | [0] | | [0] | | [0] | | [0] | | [0] | |
| Treselection | s | [0] | | [0] | | [0] | | [0] | | [0] | | [0] | |
| Sintrasearch | dB | not sent | | not sent | | not sent | | not sent | | not sent | | not sent | |
| | | Cell 4 | | | | Cell 5 | | | | Cell 6 | | | |
| Timeslot | | 0 | | DWPTS | | 0 | | DWPTS | | 0 | | DWPTS | |
| | | T1 | T2 | T1 | T2 | T1 | T2 | T1 | T2 | T1 | T2 | T1 | T2 |
| UTRA RF Channel Number | | Channel 1 | | | | Channel 1 | | | | Channel 1 | | | |
| PCCPCH_Ec/lor | dB | -3 | -3 | | | -3 | -3 | | | -3 | -3 | | |
| DwPCH_Ec/lor | dB | | | 0 | 0 | | | 0 | 0 | | | 0 | 0 |
| \hat{I}_{or}/I_{oc} | dB | [-1] | [-1] | [-1] | [-1] | [-1] | [-1] | [-1] | [-1] | [-1] | [-1] | [-1] | [-1] |
| PCCPCH RSCP | dBm | [-74] | [-74] | | | [-74] | [-74] | | | [-74] | [-74] | | |
| Qoffset | | [0] | | [0] | | [0] | | [0] | | [0] | | [0] | |

| Qhyst Tresselection Sintrasearch | s dB | [0] [0] [not sent] | [0] [0] [not sent] | [0] [0] [not sent] | [0] [0] [not sent] | [0] [0] [not sent] | [0] [0] [not sent] |
|----------------------------------------|------------------|--------------------------|--------------------------|--------------------------|--------------------------|--------------------------|--------------------------|
| I_{oc} | dBm/1. 28 MHz | -70 | | | | | |
| Propagation Condition | | AWGN | | | | | |

B.1.2.1.2 Test Requirements

The cell re-selection delay is defined as the time from the beginning of time period T2, to the moment when the UE camps on Cell 2, and starts to send the RRC CONNECTION REQUEST message to perform a Location Registration on cell 2.

The cell re-selection delay shall be less than 8 s.

NOTE:

The cell re-selection delay can be expressed as: $T_{\text{evaluateNTDD}} + T_{\text{SI}}$, where:

$T_{\text{evaluateNTDD}}$ A DRX cycle length of 1280ms is assumed for this test case, this leads to a $T_{\text{evaluateNTDD}}$ of 6.4s according to Table 4.1 in section 4.2.2.7.

T_{SI} Maximum repetition rate of relevant system info blocks that needs to be received by the UE to camp on a cell. 1280 ms is assumed in this test case.

This gives a total of 7.68 s, allow 8s in the test case.

B.1.2.2 NTDD/NTDD cell re-selection multi carrier case

B.1.2.2.1 Test Purpose and Environment

This test is to verify the requirement for the cell re-selection delay in the multi carrier case reported in section 4.1.2

This scenario implies the presence of 2 carriers and 6 cells as given in Table B-3 and B-4. Cell 1 and cell 2 shall belong to different Location Areas.

Table B.3: General test parameters for Cell Re-selection in Multi carrier case

| Parameter | | Unit | Value | Comment |
|-----------------------------------------------------|-----------------|------|-----------------------------------|-----------------------------------------------------------------------------------------------------------------------------------|
| Initial condition | Active cell | | Cell1 | |
| | Neighbour cells | | Cell2, Cell3, Cell4, Cell5, Cell6 | |
| Final condition | Active cell | | Cell2 | |
| Access Service Class (ASC#0) – Persistence value | | | 1 | Selected so that no additional delay is caused by the random access procedure. The value shall be used for all cells in the test. |
| DRX cycle length | | s | 1.28 | The value shall be used for all cells in the test. |
| T1 | | s | 15 | |
| T2 | | s | 15 | |

Table B.4: Cell re-selection multi carrier multi cell case

| Parameter | Unit | Cell 1 | | | | Cell 2 | | | | Cell 3 | | | |
|------------------------|------|------------|-------|------------|------|------------|-------|------------|------|------------|-------|------------|------|
| Timeslot Number | | 0 | | DWPTS | | 0 | | DWPTS | | 0 | | DWPTS | |
| | | T1 | T2 | T1 | T2 | T1 | T2 | T1 | T2 | T1 | T2 | T1 | T2 |
| UTRA RF Channel Number | | Channel 1 | | | | Channel 2 | | | | Channel 1 | | | |
| PCCPCH_Ec/lor | dB | -3 | -3 | | | -3 | -3 | | | -3 | -3 | | |
| DwPCH_Ec/lor | dB | | | 0 | 0 | | | 0 | 0 | | | 0 | 0 |
| \hat{I}_{or}/I_{oc} | dB | [9] | [7] | [9] | [7] | [7] | [9] | [7] | [9] | [-1] | [-1] | [-1] | [-1] |
| PCCPCH RSCP | dBm | [-64] | [-66] | | | [-66] | [-64] | | | [-74] | [-74] | | |
| Qoffset | | [0] | | [0] | | [0] | | [0] | | [0] | | [0] | |
| Qhyst | | [0] | | [0] | | [0] | | [0] | | [0] | | [0] | |
| Treselection | s | [0] | | [0] | | [0] | | [0] | | [0] | | [0] | |
| Qintrasearch | dB | [not sent] | | [not sent] | | [not sent] | | [not sent] | | [not sent] | | [not sent] | |
| | | Cell 4 | | | | Cell 5 | | | | Cell 6 | | | |
| Timeslot | | 0 | | DWPTS | | 0 | | DWPTS | | 0 | | DWPTS | |
| | | T1 | T2 | T1 | T2 | T1 | T2 | T1 | T2 | T1 | T2 | T1 | T2 |
| UTRA RF Channel Number | | Channel | | | | Channel 2 | | | | Channel | | | |
| PCCPCH_Ec/lor | dB | -3 | -3 | | | -3 | -3 | | | -3 | -3 | | |
| DwPCH_Ec/lor | dB | | | 0 | 0 | | | 0 | 0 | | | 0 | 0 |
| \hat{I}_{or}/I_{oc} | dB | [-1] | [-1] | [-1] | [-1] | [-1] | [-1] | [-1] | [-1] | [-1] | [-1] | [-1] | [-1] |
| PCCPCH RSCP | dBm | [-74] | [-74] | | | [-74] | [-74] | | | [-74] | [-74] | | |
| Qoffset | | [0] | | [0] | | [0] | | [0] | | [0] | | [0] | |

| Qhyst Treselction Qintrasearch | s dB | [0] [0] [not sent] | [0] [0] [not sent] | [0] [0] [not sent] | [0] [0] [not sent] | [0] [0] [not sent] | [0] [0] [not sent] |
|--------------------------------------|------------------|--------------------------|--------------------------|--------------------------|--------------------------|--------------------------|--------------------------|
| I_{oc} | dBm/3. 84 MHz | -70 | | | | | |
| Propagation Condition | | AWGN | | | | | |

B.1.2.2.2 Test Requirements

The cell re-selection delay is defined as the time from the beginning of time period T2, to the moment when the UE camps on Cell 2, and starts to send the RRC CONNECTION REQUEST message to perform a Location Registration on cell 2.

The cell re-selection delay shall be less than 8 s.

NOTE: The cell re-selection delay can be expressed as: $T_{\text{evaluateNTDD}} + T_{\text{SI}}$, where:

$T_{\text{evaluateNTDD}}$ A DRX cycle length of 1280ms is assumed for this test case, this leads to a $T_{\text{evaluateNTDD}}$ of 6.4s according to Table 4.1 in section 4.1.5.

T_{SI} Maximum repetition rate of relevant system info blocks that needs to be received by the UE to camp on a cell. 1280 ms is assumed in this test case.

This gives a total of 7.68 s, allow 8s in the test case.

B.1.2.3 High chip rate TDD cell re-selection

B.1.2.3.1 Test Purpose and Environment

This test is to verify the requirement for the NTDD/TDD cell re-selection delay reported in section 4.1.2.3.

This scenario implies the presence of 1 low chip rate (NTDD) and 1 high chip rate (TDD) cell as given in Table B-5 and B-6.

The ranking of the cells shall be made according to the cell reselection criteria specified in TS 25.304.

For this test environment the ranking/mapping function indicated in the broadcast of cell 1 shall be in such a way as to enable the UE to evaluate that the NTDD cell 1 is better ranked as the TDD cell 2 during T1 and the TDD cell 2 is better ranked than the NTDD cell 1 during T2.

Cell 1 and cell 2 shall belong to different Location Areas.

Table B.5: General test parameters for TDD low chip rate to TDD high chip rate cell re-selection

| Parameter | | Unit | Value | Comment |
|-----------------------------------------------------|----------------|------|-------|-----------------------------------------------------------------------------------------------------------------------------------|
| Initial condition | Active cell | | Cell1 | NTDD cell |
| | Neighbour cell | | Cell2 | TDD cell |
| Final condition | Active cell | | Cell2 | |
| Access Service Class (ASC#0) - Persistence value | | | 1 | Selected so that no additional delay is caused by the random access procedure. The value shall be used for all cells in the test. |
| DRX cycle length | | s | 1.28 | |
| T1 | | s | 15 | Cell 1 better ranked than cell 2 |
| T2 | | s | 15 | Cell2 better ranked than cell 1 |

Table B.6: Test parameters for TDD low chip rate to TDD high chip rate cell re-selection

| Parameter | Unit | Cell 1 | | | | Cell 2 | | | |
|------------------------|--------------|-----------|-------|-------|----|-----------|-------|-------|-------|
| | | 0 | | DwPts | | 0 | | 8 | |
| Timeslot Number | | | | | | | | | |
| | | T1 | T2 | T1 | T2 | T1 | T2 | T1 | T2 |
| UTRA RF Channel Number | | Channel 1 | | | | Channel 2 | | | |
| PCCPCH_Ec/lor | dB | -3 | -3 | | | -3 | -3 | | |
| DwPCH_Ec/lor | dB | | | 0 | 0 | n.a. | | n.a. | |
| SCH_Ec/lor | dB | n.a. | | n.a. | | -9 | -9 | -9 | -9 |
| SCH_toffset | | n.a. | | n.a. | | 0 | 0 | 0 | 0 |
| PICH_Ec/lor | | | | | | | | -3 | -3 |
| OCNS | dB | n.a. | | n.a. | | -4,28 | -4,28 | -4,28 | -4,28 |
| \hat{I}_{or}/I_{oc} | dB | [10] | [7] | | | [7] | [10] | [7] | [10] |
| I_{oc} | dBm/3.84 MHz | -70 | | | | | | | |
| PCCPCH_RSCP | dBm | [-63] | [-66] | | | [-66] | [-63] | | |
| Treselection | s | 0 | | | | 0 | | | |
| Propagation Condition | | AWGN | | | | AWGN | | | |

B.1.2.3.2 Test Requirements

The cell re-selection delay is defined as the time from the beginning of time period T2, to the moment when the UE camps on Cell 2, and starts to send the RRC CONNECTION REQUEST message to perform a Location Registration on cell 2.

The cell re-selection delay shall be less than 8 s.

Note: The re-selection delay equals $T_{TDD\text{evaluate}} + T_{\text{rep}}$ repetition period of the broadcast information of the selected cell

B.1.2.4 FDD cell re-selection

B.1.2.4.1 Test Purpose and Environment

This test is to verify the requirement for the NTDD/FDD cell re-selection delay reported in section 4.1.2.4.

This scenario implies the presence of 1 low chip rate TDD and 1 FDD cell as given in Table B-5 and B-6.

The ranking of the cells shall be made according to the cell reselection criteria specified in TS 25.304.

For this test environment the ranking/mapping function indicated in the broadcast of cell 1 shall be in such a way as to enable the UE to evaluate that the NTDD cell 1 is better ranked as the FDD cell 2 during T1 and the FDD cell 2 is better ranked than the NTDD cell 1 during T2.

Cell 1 and cell 2 shall belong to different Location Areas.

Table B.7: General test parameters for the TDD/FDD cell re-selection

| Parameter | | Unit | Value | Comment |
|-----------------------------------------------------|-----------------|------|-------|-----------------------------------------------------------------------------------------------------------------------------------|
| Initial condition | Active cell | | Cell1 | NTDD cell |
| | Neighbour cells | | Cell2 | FDD cell |
| Final condition | Active cell | | Cell2 | |
| Access Service Class (ASC#0) - Persistence value | | | 1 | Selected so that no additional delay is caused by the random access procedure. The value shall be used for all cells in the test. |
| DRX cycle length | | s | 1.28 | The value shall be used for all cells in the test. |
| T1 | | s | 15 | |
| T2 | | s | 15 | |

Table B.8: Test parameters for the NTDD/FDD cell re-selection

| Parameter | Unit | Cell 1 | | | | Cell 2 | |
|------------------------|--------------|-----------|-----|-------|----|-----------|------|
| | | 0 | | DwPts | | n.a. | |
| Timeslot Number | | | | | | | |
| | | T1 | T2 | T1 | T2 | T1 | T2 |
| UTRA RF Channel Number | | Channel 1 | | | | Channel 2 | |
| PCCPCH_Ec/lor | dB | -3 | -3 | | | -12 | -12 |
| DwPCH_Ec/lor | dB | | | 0 | 0 | n.a. | |
| CPICH_Ec/lor | dB | n.a. | | n.a. | | -10 | -10 |
| SCH_Ec/lor | dB | n.a. | | n.a. | | -12 | -12 |
| PICH_Ec/lor | | | | | | -15 | -15 |
| OCNS | dB | n.a. | | n.a. | | - | - |
| \hat{I}_{or}/I_{oc} | dB | [] | [] | | | [] | [] |
| I_{oc} | dBm/1.28 MHz | -70 | | | | | |
| PCCPCH_RSCP | dBm | [] | [] | | | n.a. | n.a. |
| CPICH_Ec/lo | | n.a. | | | | [] | [] |
| Treselection | s | 0 | | | | 0 | |
| Propagation Condition | | AWGN | | | | | |

B.1.2.4.2 Test Requirements

The cell re-selection delay is defined as the time from the beginning of time period T2, to the moment when the UE camps on Cell 2, and starts to send preambles on the PRA CH for sending the RRC CONNECTION REQUEST message to perform a Location Registration on cell 2.

The cell re-selection delay shall be less than 8 s.

NOTE:

The cell re-selection delay can be expressed as: $T_{\text{evaluateFDD}} + T_{\text{SI}}$, where:

$T_{\text{evaluateFDD}}$ See Table 4.1 in section 4.1.5.

T_{SI} Maximum repetition rate of relevant system info blocks that needs to be received by the UE to camp on a cell. 1280 ms is assumed in this test case.

This gives a total of 7.68 s, allow 8s in the test case.

B.1.3 Inter-RAT(GSM) cell re-selection

B.1.3.1 Scenario

B.1.3.1.1 Test Purpose and Environment

This test is to verify the requirement for the UTRAN to GSM cell re-selection delay reported in section 4.1.3

This scenario implies the presence of 1 UTRAN serving cell, and 1 GSM cell to be re-selected. Test parameters are given in Table, B-9, B-10, B-11.

The ranking of the cells shall be made according to the cell reselection criteria specified in TS 25.304.

For this test environment the ranking/mapping function indicated in the broadcast of cell 1 shall be in such a way as to enable the UE to evaluate that the NTDD cell 1 is better ranked as the GSM cell 2 during T1 and the GSM cell 2 is better ranked than the NTDD cell 1 during T2.

Table B.9: General test parameters for UTRAN (NTDD) to GSM Cell Re-selection

| | Parameter | Unit | Value | Comment |
|-------------------|------------------|------|-------|---------|
| Initial condition | Active cell | | Cell1 | |
| | Neighbour cell | | Cell2 | |
| Final condition | Active cell | | Cell2 | |
| | DRX cycle length | s | 1.28 | |
| | T1 | s | 15 | |
| | T2 | s | 15 | |

Table B.10: Cell re-selection UTRAN to GSM cell case (cell 1)

| Parameter | Unit | Cell 1 (UTRA) | | | |
|------------------------------------------------|--------------|---------------|-------|-----------|-----|
| | | 0 | | DwPTS | |
| Timeslot Number | | T1 | T2 | T1 | T2 |
| UTRA RF Channel Number | | Channel 1 | | Channel 1 | |
| PCCPCH_Ec/I _{or} | dB | -3 | -3 | | |
| DwPCH_Ec/I _{or} | dB | | | 0 | 0 |
| \hat{I}_{or}/I_{oc} | dB | [9] | [7] | [9] | [7] |
| I_{oc} | dBm/1.28 MHz | -70 | | -70 | |
| PCCPCH RSCP | dBm | [-64] | [-66] | | |
| Propagation Condition | | AWGN | | AWGN | |
| Cell_selection_and_reselection_quality_measure | | P-CCPCH RSCP | | | |
| Treselection | s | [] | | | |
| Ssearch _{RAT} | dB | [] | | | |

Table B.11: Cell re-selection UTRAN to GSM cell case (cell 2)

| Parameter | Unit | Cell 2 (GSM) | |
|----------------------------|------|--------------|-----|
| | | T1 | T2 |
| Absolute RF Channel Number | | ARFCN 1 | |
| RXLEV | dBm | -80 | -70 |
| RXLEV_ACCESS_MIN | dBm | [-100] | |
| MS_TXPWR_MAX_CCH | dBm | 30 | |

B.1.3.1.2 Test Requirements

The cell re-selection delay is defined as the time from the beginning of time period T2, to the moment when the UE camps on Cell 2, and starts to send LOCATION UPDATING REQUEST message to perform a Location update.

The cell re-selection delay shall be less than [8] s.

NOTE: The UE shall keep a running average of 4 measurements, thus gives 4*1280ms (T_{measureGSM} Table 4.1), means 5.12 seconds can elapse from the beginning of time period T2 before the UE has finished the measurements to evaluate that the GSM cell fulfils the re-selection criteria.

The cell selection parameters in the BCCH of the GSM cell in system info 3 and 4 are transmitted at least every second.

B.2 UTRAN Connected Mode Mobility

B.2.1 1.28 Mcps TDD/TDD Handover

(void)

B.2.2 1.28 Mcps TDD/FDD Handover

NOTE: This section is included for consistency with numbering with section 4.2, currently no test covering requirements in sections 4.2.2.2.1 and 4.2.2.2.2 exists.

B.2.3 1.28 Mcps TDD/GSM Handover

NOTE: This section is included for consistency with numbering with section 4.2 currently no test covering requirements in sections 4.2.3.2.1 and 4.2.3.2.2 exists.

B.2.4 Cell Re-selection in CELL_FACH

B.2.4.1 One frequency present in neighbour list

B.2.4.1.1 Test Purpose and Environment

Note: Cell reselection in Cell-fach is still under discussion.

The purpose of this test is to verify the requirement for the cell re-selection delay in CELL_FACH state in the single carrier case reported in section 4.2.4.2.1.1.

The test parameters are given in Table B.12 and B.13

Table B.12: General test parameters for Cell Re-selection in CELL_FACH

| Parameter | | Unit | Value | Comment |
|-------------------|-----------------|------|-----------------------------------|--------------------------------------------------------------------------------------|
| initial condition | Active cell | | Cell1 | |
| | Neighbour cells | | Cell2, Cell3, Cell4, Cell5, Cell6 | |
| final condition | Active cell | | Cell2 | |
| T1 | | s | | T1 need to be defined so that cell re-selection reaction time is taken into account. |
| T2 | | s | | T2 need to be defined so that cell re-selection reaction time is taken into account. |

Table B.13: Cell specific test parameters for Cell Re-selection in CELL_FACH

| Parameter | Unit | Cell 1 | | | | Cell 2 | | | | Cell 3 | | | |
|------------------------|------|-----------|------|-------|------|-----------|------|-------|------|-----------|------|-------|------|
| Timeslot Number | | 0 | | DWPTS | | 0 | | DWPTS | | 0 | | DWPTS | |
| | | T1 | T2 | T1 | T2 | T1 | T2 | T1 | T2 | T1 | T2 | T1 | T2 |
| UTRA RF Channel Number | | Channel 1 | | | | Channel 1 | | | | Channel 1 | | | |
| PCCPCH_Ec/lor | DB | -3 | -3 | | | -3 | -3 | | | -3 | -3 | | |
| DwPCH_Ec/lor | DB | | | 0 | 0 | | | 0 | 0 | | | 0 | 0 |
| \hat{I}_{or}/I_{oc} | DB | [9] | [7] | [9] | [7] | [7] | [9] | [7] | [9] | [-1] | [-1] | [-1] | [-1] |
| PCCPCH RSCP | DBm | -64 | -66 | | | -66 | -64 | | | -74 | -74 | | |
| Qoffset | | [] | | [] | | [] | | [] | | [] | | [] | |
| Qhyst | DBm | [] | | [] | | [] | | [] | | [] | | [] | |
| Treselection | | [] | | [] | | [] | | [] | | [] | | [] | |
| Qintrasearch | DB | [] | | [] | | [] | | [] | | [] | | [] | |
| | | Cell 4 | | | | Cell 5 | | | | Cell 6 | | | |
| Timeslot | | 0 | | DWPTS | | 0 | | DWPTS | | 0 | | DWPTS | |
| | | T1 | T2 | T1 | T2 | T1 | T2 | T1 | T2 | T1 | T2 | T1 | T2 |
| UTRA RF Channel Number | | Channel 1 | | | | Channel 1 | | | | Channel 1 | | | |
| PCCPCH_Ec/lor | DB | -3 | -3 | | | -3 | -3 | | | -3 | -3 | | |
| DwPCH_Ec/lor | DB | | | 0 | 0 | | | 0 | 0 | | | 0 | 0 |
| \hat{I}_{or}/I_{oc} | DB | [-1] | [-1] | [-1] | [-1] | [-1] | [-1] | [-1] | [-1] | [-1] | [-1] | [-1] | [-1] |
| PCCPCH RSCP | DBm | -74 | -74 | | | -74 | -74 | | | -74 | -74 | | |
| Qoffset | | [] | | [] | | [] | | [] | | [] | | [] | |

| | | | | | | | |
|---------------------------------------|------------------|-------------------|-------------------|-------------------|-------------------|-------------------|-------------------|
| Qhyst Treselection Qintrasearch | DBm DB | [] [] [] | [] [] [] | [] [] [] | [] [] [] | [] [] [] | [] [] [] |
| I_{oc} | dBm/1. 28 MHz | -70 | | | | | |
| Propagation Condition | | AWGN | | | | | |

B.2.4.1.2 Test Requirements

The UE shall select cell 2 within a cell re-selection delay specified in 4.2.4.2.1.1

B.2.4.2 Two frequencies present in the neighbour list

B.2.4.2.1 Test Purpose and Environment

The purpose of this test is to verify the requirement for the cell re-selection delay in CELL_FACH state in section 4.2.4.2.1.2. The test parameters are given in Table B.14 and B.15.

Table B.14: General test parameters for Cell Re-selection in CELL_FACH

| Parameter | | Unit | Value | Comment |
|-------------------|-----------------|------|-----------------------------------|--------------------------------------------------------------------------------------|
| initial condition | Active cell | | Cell1 | |
| | Neighbour cells | | Cell2, Cell3, Cell4, Cell5, Cell6 | |
| final condition | Active cell | | Cell2 | |
| T1 | | s | | T1 need to be defined so that cell re-selection reaction time is taken into account. |
| T2 | | s | | T2 need to be defined so that cell re-selection reaction time is taken into account. |

Table B.15: Cell specific test parameters for Cell re-selection in CELL_FACH state

| Parameter | Unit | Cell 1 | | | | Cell 2 | | | | Cell 3 | | | |
|------------------------|------|-----------|-------|-------|------|-----------|-------|-------|------|-----------|-------|-------|------|
| Timeslot Number | | 0 | | DWPTS | | 0 | | DWPTS | | 0 | | DWPTS | |
| | | T1 | T2 | T1 | T2 | T1 | T2 | T1 | T2 | T1 | T2 | T1 | T2 |
| UTRA RF Channel Number | | Channel 1 | | | | Channel 2 | | | | Channel 1 | | | |
| PCCPCH_Ec/lor | DB | -3 | -3 | | | -3 | -3 | | | -3 | -3 | | |
| DwPCH_Ec/lor | DB | | | 0 | 0 | | | 0 | 0 | | | 0 | 0 |
| \hat{I}_{or}/I_{oc} | DB | [9] | [7] | [9] | [7] | [7] | [9] | [7] | [9] | [-1] | [-1] | [-1] | [-1] |
| PCCPCH RSCP | DBm | [-64] | [-66] | | | [-66] | [-64] | | | [-74] | [-74] | | |
| Qoffset | | | | | | | | | | | | | |
| Qhyst | DBm | | | | | | | | | | | | |
| Treselection | | | | | | | | | | | | | |
| Qintrasearch | DB | | | | | | | | | | | | |
| | | Cell 4 | | | | Cell 5 | | | | Cell 6 | | | |
| Timeslot | | 0 | | DWPTS | | 0 | | DWPTS | | 0 | | DWPTS | |
| | | T1 | T2 | T1 | T2 | T1 | T2 | T1 | T2 | T1 | T2 | T1 | T2 |
| UTRA RF Channel Number | | Channel | | | | Channel 2 | | | | Channel | | | |
| PCCPCH_Ec/lor | DB | -3 | -3 | | | -3 | -3 | | | -3 | -3 | | |
| DwPCH_Ec/lor | DB | | | 0 | 0 | | | 0 | 0 | | | 0 | 0 |
| \hat{I}_{or}/I_{oc} | DB | [-1] | [-1] | [-1] | [-1] | [-1] | [-1] | [-1] | [-1] | [-1] | [-1] | [-1] | [-1] |
| PCCPCH RSCP | DBm | [-74] | [-74] | | | [-74] | [-74] | | | [-74] | [-74] | | |
| Qoffset | | | | | | | | | | | | | |

| | | | | | | | |
|-------------------------------------------------------------------------------|------------------|-------------------|-------------------|-------------------|-------------------|-------------------|-------------------|
| Qhyst Treselection Qintrasearch | DBm DB | [] [] [] | [] [] [] | [] [] [] | [] [] [] | [] [] [] | [] [] [] |
| I_{oc} | dBm/1. 28 MHz | -70 | | | | | |
| Propagation Condition | | AWGN | | | | | |
| NOTE: PCCPCH_RSCP is the quality measure for cell selection and re-selection. | | | | | | | |

B.2.4.2.2 Test Requirements

The UE shall select cell 2 within a cell re-selection delay specified in 4.2.4.2.1.

B.2.5 Cell Re-selection in CELL_PCH

Same requirements and test cases valid as for cell re-selection in idle mode.

B.2.6 Cell Re-selection in URA_PCH

Same requirements and test cases valid as for cell re-selection in idle mode.

B.3 Dynamic Channel Allocation

(void)

B.4 Timing characteristics

(void)

B.5 UE Measurements Procedures

B.5.1 1.28 Mcps TDD measurements

B.5.1.1 Event triggered reporting in AWGN propagation conditions

B.5.1.1.1 Test Purpose and Environment

This test will derive that the terminal makes correct reporting of an event Cell 1 is the active cell, Cell 2 is a neighbour cell on the used frequency. The power level on Cell 1 is kept constant and the power level of Cell 2 is changed using "change of best cell event" as illustrated in Figure B.1. The test parameters are shown in Table B.16. Hysteresis, absolute Threshold and Time to Trigger values are given in the table below and they are signalled from test device. In the measurement control information it is indicated to the UE that event-triggered reporting with Event 1G shall be used. P-CCPCH RSCP of the best cell has to be reported together with Event 1G reporting. New measurement control information, which defines neighbour cells etc., is always sent before the event starts.

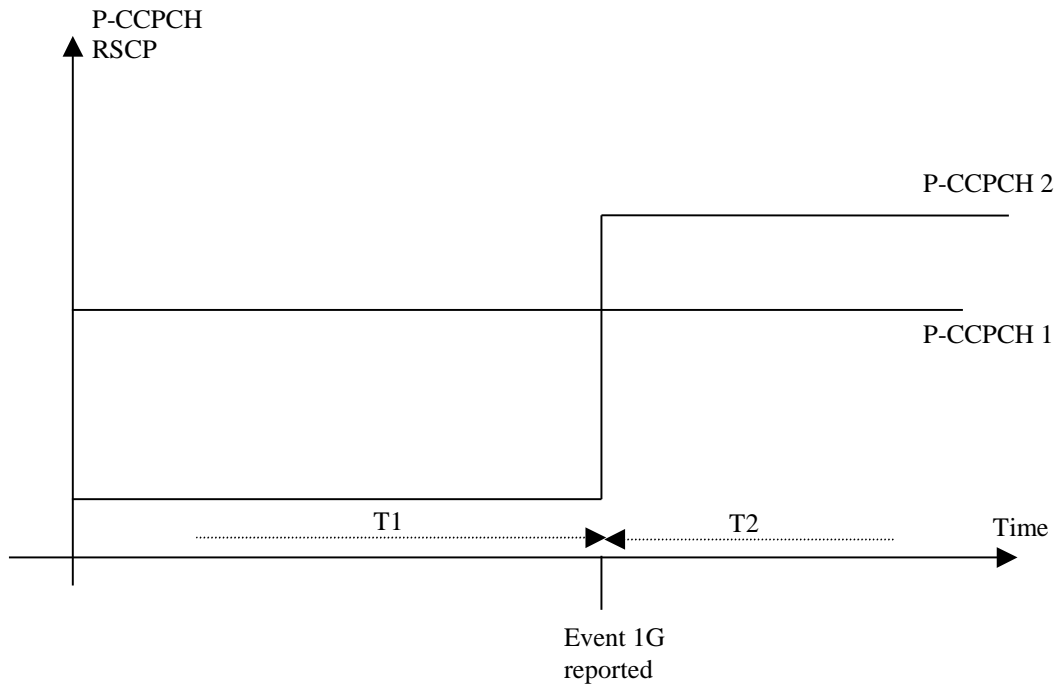

Figure B.1: Illustration of parameters for handover measurement reporting test case

Table B.16

| Parameter | Unit | Cell 1 | | | | Cell 2 | | | |
|--------------------------|--------------|-----------|-------|-------|----|-----------|-------|-------|----|
| | | 0 | | DwPTS | | 0 | | DwPTS | |
| | | T1 | T2 | T1 | T2 | T1 | T2 | T1 | T2 |
| UTRAN RF Channel Number | | Channel 1 | | | | Channel 2 | | | |
| PCCPCH_Ec/Ior | dB | -3 | | | | -3 | | | |
| DwPCH_Ec/Ior | dB | | | 0 | | | | 0 | |
| \hat{I}_{or}/I_{oc} | dB | [3] | [3] | | | -Infinity | [6] | | |
| I_{oc} | dBm/1.28 MHz | -70 | | | | | | | |
| PCCPCH_RSCP | dBm | [-70] | [-70] | | | -Infinity | [-67] | | |
| Absolute Threshold (SIR) | dB | [] | | | | | | | |
| Hysteresis | dB | [] | | | | | | | |
| Time to Trigger | msec | [] | | | | | | | |
| Propagation Condition | | AWGN | | | | | | | |

NOTE: The DPCH of all cells are located in a timeslot other than 0.

B.5.1.1.1.1 Explanation difference

In 1.28 Mcps TDD the PICH is mapped onto P-CCPCH as describe in TR25.928. So the PICH-Ec/Ior is no longer used. The function of the SCH is achieved by DwPTS in 1.28 Mcps TDD and it is allocated to a dedicated timeslot. And the P-CCPCH is always mapped onto time slot 0, so time slot 8 is not considered in 1.28 Mcps TDD.

The parameter \hat{I}_{or}/I_{oc} is measured to report to UE for its handover or cell selection and reselection.

B.5.1.1.2 Test Requirements

The UE shall send one Event 1G triggered measurement report, with a measurement reporting delay less than [480] ms from the beginning of time period T2.

The UE shall not send event triggered measurement reports, as long as the reporting criteria are not fulfilled.

B.5.2 FDD measurements

B.5.2.1 Correct reporting of neighbours in AWGN propagation condition

B.5.2.1.1 Test Purpose and Environment

The purpose of this test is to verify that the UE makes correct reporting of an event when doing inter frequency measurements. The test will partly verify the requirements in section 4.5.1.2.2.

This test will derive that the terminal makes correct reporting of an event Cell 1 is the active cell, Cell 2 is a neighbour cell on the used frequency. The power level on Cell 1 is kept constant and the power level of Cell 2 is changed using "change of best cell event" as illustrated in Figure B.5.1. The test parameters are shown in Table B.5.2. Hysteresis, absolute Threshold and Time to Trigger values are given in the table below and they are signalled from test device. In the measurement control information it is indicated to the UE that event-triggered reporting with Event 2C shall be used. P-CCPCH RSCP of the best cell has to be reported together with Event 2C reporting. New measurement control information, which defines neighbour cells etc., is always sent before the event starts.

The test parameters are shown in Table B.17.

Table B.17: Cell Specific Parameters for Correct Reporting of Neighbours in AWGN Propagation Condition

| Parameter | Unit | Cell 1 | | | | Cell 2 | | | |
|--------------------------|--------------|-----------|-------|-------|----|-----------|-------|-------|----|
| | | 0 | | DwPTS | | 0 | | DwPTS | |
| Timeslot Number | | T1 | T2 | T1 | T2 | T1 | T2 | T1 | T2 |
| UTRA RF Channel Number | | Channel 1 | | | | Channel 2 | | | |
| PCCPCH_Ec/Ior | dB | -3 | | | | -3 | | | |
| DwPCH_Ec/Ior | dB | | | 0 | | | | 0 | |
| \hat{I}_{or}/I_{oc} | dB | [3] | [3] | | | -Infinity | [6] | | |
| I_{oc} | dBm/1.28 MHz | -70 | | | | | | | |
| PCCPCH_RSCP | dBm | [-70] | [-70] | | | -Infinity | [-67] | | |
| Absolute Threshold (SIR) | dB | [] | | | | | | | |
| Hysteresis | dB | [] | | | | | | | |
| Time to Trigger | msec | [] | | | | | | | |
| Propagation Condition | | AWGN | | | | | | | |

NOTE: The DPCH of all cells are located in a timeslot other than 0.

B.5.2.1.1.1 Explanation difference

In 1.28 Mcps TDD the PICH is mapped onto P-CCPCH as describe in TR25.928. So the PICH-Ec/Ior is no longer used. The function of the SCH is achieved by DwPTS in 1.28 Mcps TDD and it is allocated to a dedicated timeslot. And the P-CCPCH is always mapped onto time slot 0, so time slot 8 is not considered in 1.28 Mcps TDD.

B.5.2.1.2 Test Requirements

The UE shall send one Event 2C triggered measurement report, with a measurement reporting delay less than [5] s from the beginning of time period T2.

The UE shall not send any measurement reports, as long as the reporting criteria are not fulfilled.

B.6 Measurement Performance Requirements

B.6.1 Measurement Performance for UE

If not otherwise stated, the test parameters in table B.6.1 should be applied for UE RX measurements requirements in this clause.

B.6.1.1 TDD intra frequency measurements

If not otherwise stated, the test parameters in table B.18 should be applied for UE RX measurements requirements in this section.

Table B.18: Intra frequency test parameters for UE RX Measurements

| Parameter | Unit | Cell 1 | | | | Cell 2 | | | |
|---------------------------|--------------|-----------|-----|-------|----|-----------|-----|-------|----|
| | | 0 | | DwPTS | | 0 | | DwPTS | |
| Timeslot Number | | T1 | T2 | T1 | T2 | T1 | T2 | T1 | T2 |
| UTRA RF Channel Number | | Channel 1 | | | | Channel 2 | | | |
| PCCPCH_Ec/I _{or} | dB | -3 | | | | -3 | | | |
| DwPCH_Ec/I _{or} | dB | | | 0 | | | | 0 | |
| \hat{I}_{or}/I_{oc} | dB | [3] | [3] | | | -Infinity | [6] | | |
| I_{oc} | dBm/1.28 MHz | -70 | | | | | | | |
| Range 1:I _o | dBm | -94...-70 | | | | -94...-70 | | | |
| Range 2:I _o | | -94...-50 | | | | -94...-50 | | | |
| Propagation condition | | AWGN | | | | | | | |

NOTE 1: $P\text{-CCPCH_RSCP}_{1,2} \geq -[102]$ dBm.

NOTE 2: $|P\text{-CCPCH_RSCP}_1 - P\text{-CCPCH_RSCP}_2| \leq 20$ dB.

NOTE 3: $|I_o - P\text{-CCPCH_RSCP}| \leq [20]$ dB.

NOTE 4: I_{oc} level shall be adjusted according the total signal power I_o at receiver input and the geometry factor \hat{I}_{or}/I_{oc} .

NOTE 5: The DPCH of all cells are located in a timeslot other than 0

B.6.1.1.1 Explanation difference

In 1.28 Mcps TDD the PICH is mapped onto P-CCPCH as describe in TR25.928. So the PICH-Ec/I_{or} is no longer used. The function of the SCH is achieved by DwPTS in 1.28 Mcps TDD and it is allocated to a dedicated timeslot. And the P-CCPCH is always mapped onto time slot 0, so time slot 8 is not considered in 1.28 Mcps TDD.

The parameter \hat{I}_{or}/I_{oc} is measured to report to UE for its handover or cell selection and reselection.

B.6.1.2 TDD inter frequency measurements

If not otherwise stated, the test parameters in table B.19 should be applied for UE RX measurements requirements in this section.

Table B.19: Intra frequency test parameters for UE RX Measurements

| Parameter | Unit | Cell 1 | | | | Cell 2 | | | |
|------------------------|--------------|-----------|-----|-------|----|-----------|-----|-------|----|
| | | 0 | | DwPTS | | 0 | | DwPTS | |
| Timeslot Number | | T1 | T2 | T1 | T2 | T1 | T2 | T1 | T2 |
| UTRA RF Channel Number | | Channel 1 | | | | Channel 2 | | | |
| PCCPCH_Ec/Ior | dB | -3 | | | | -3 | | | |
| DwPCH_Ec/Ior | dB | | | 0 | | | | 0 | |
| \hat{I}_{or}/I_{oc} | dB | [3] | [3] | | | -Infinity | [6] | | |
| I_{oc} | dBm/1.28 MHz | -70 | | | | | | | |
| Range 1: Ior | dBm | -94...-70 | | | | -94...-70 | | | |
| Range 2: Ior | | -94...-50 | | | | -94...-50 | | | |
| Propagation condition | | AWGN | | | | | | | |

NOTE 1: $P\text{-CCPCH_RSCP}_{1,2} \geq -[102]$ dBm.

NOTE 2: $|P\text{-CCPCH_RSCP}_1 - P\text{-CCPCH_RSCP}_2| \leq 20$ dB.

NOTE 3: $|I_{or} - P\text{-CCPCH_RSCP}_{1,2}| \leq [20]$ dB.

NOTE 4: I_{oc} level shall be adjusted according the total signal power I_o at receiver input and the geometry factor \hat{I}_{or}/I_{oc} .

NOTE 5: The DPCH of all cells are located in a timeslot other than 0

B.6.1.2.1 Explanation difference

In 1.28 Mcps TDD the PICH is mapped onto P-CCPCH as describe in TR25.928. So the PICH-Ec/Ior is no longer used. The function of the SCH is achieved by DwPTS in 1.28 Mcps TDD and it is allocated to a dedicated timeslot. And the P-CCPCH is always mapped onto time slot 0, so time slot 8 is not considered in 1.28 Mcps TDD.

The parameter \hat{I}_{or}/I_{oc} is measured to report to UE for its handover or cell selection and reselection.

B.6.1.3 UTRA carrier RSSI inter frequency measurements

The table B.20 and notes 1,2 define the limits of signal strengths, where the requirement is applicable.

Table B.20: UTRA carrier RSSI Inter frequency test parameters

| Parameter | Unit | Cell 1 | Cell 2 |
|------------------------|--------------|-----------|-----------|
| UTRA RF Channel number | - | Channel 1 | Channel 2 |
| Ior/Ioc | DB | -1 | -1 |
| Ioc | dBm/1.28 MHz | Note 2 | Note 2 |
| Range 1: Ior | dBm/1.28 MHz | -94...-70 | -94...-70 |
| Range 2: Ior | | -94...-50 | -94...-50 |
| Propagation condition | - | AWGN | |

NOTE 1: For relative accuracy requirement $|Channel\ 1_I_{or} - Channel\ 2_I_{or}| < 20$ dB.

NOTE 2: I_{oc} level shall be adjusted according the total signal power I_o at receiver input and the geometry factor \hat{I}_{or}/I_{oc} .

B.6.2 Measurement Performance for UTRAN

If not otherwise stated, the test parameters in table B.21 should be applied for UTRAN RX measurements requirements in this section.

Table B.21: Intra frequency test parameters for UTRAN RX Measurements

| Parameter | Unit | Cell 1 |
|------------------------|--------------|-----------|
| UTRA RF Channel number | | Channel 1 |
| Timeslot | | [] |
| DPCH Ec/Ior | dB | [] |
| Ior/Ioc | dB | [] |
| Ioc | dBm/1.28 MHz | -89 |
| Range: Io | dBm | -105..-74 |
| Propagation condition | AWGN | |

Annex C (informative): Measurement Channels

C.1 General

(void)

C.2 Reference Measurement Channels (Downlink)

C.2.0 UL reference measurement channel (12.2 kbps, for definition of UE Tx parameters)

Table C.0

| Parameter | Value |
|-----------------------------------------------|-----------------------|
| Information data rate | 12.2 kbps |
| RU's allocated | 1TS (1*SF8) = 2RU/5ms |
| Midamble | 144 |
| Interleaving | 20 ms |
| Power control (TPC) | 4 Bit/user/10ms |
| TFCI | 16 Bit/user/10ms |
| 4 Bit reserved for future use (place of SS) | 4 Bit/user/10ms |
| Inband signalling DCCH | 2.4 kbps |
| Puncturing level at Code rate 1/3: DCH / DCCH | 33% / 33% |

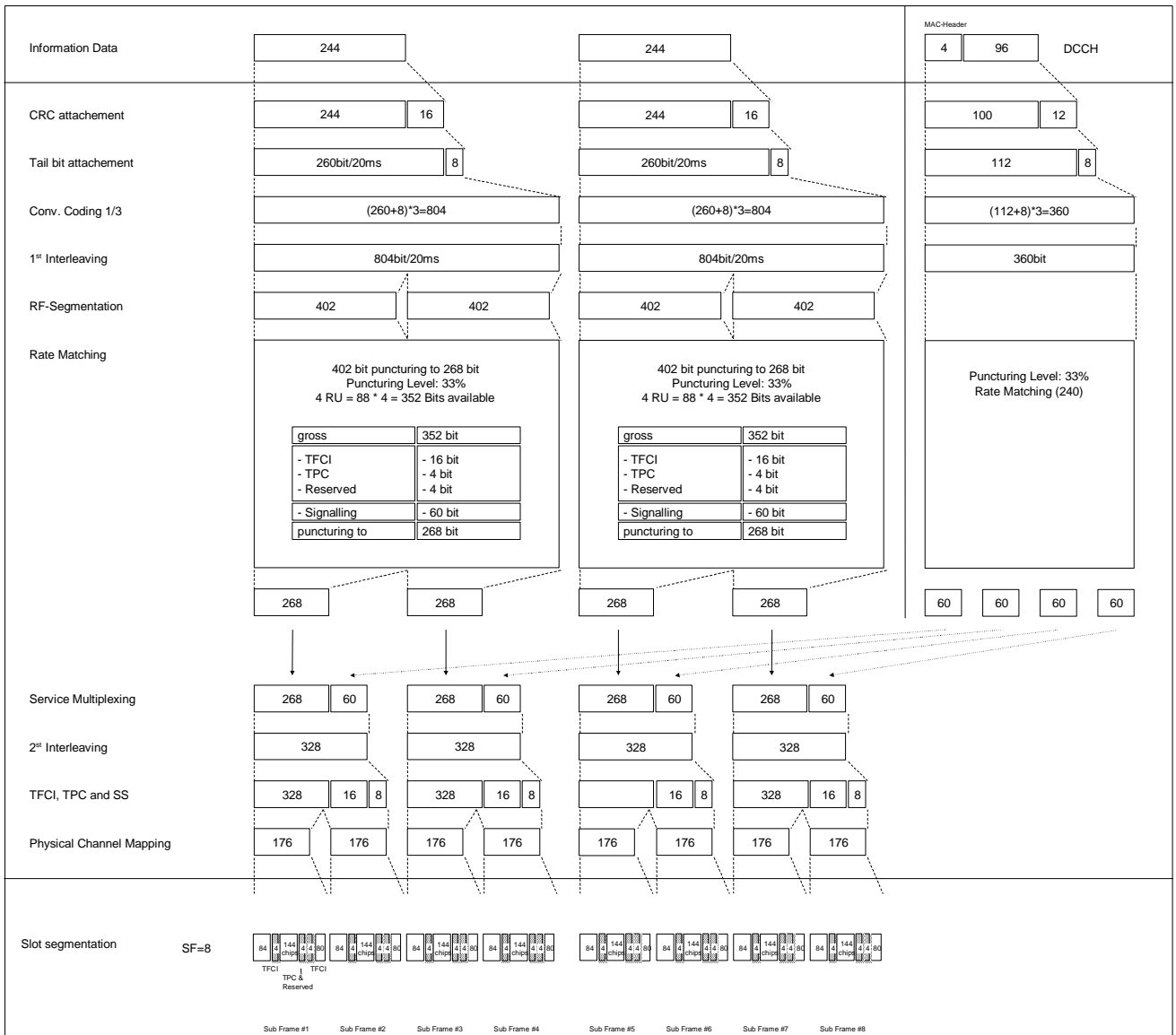

Figure C.0

C.2.0.1 Rationale

There is only one burst type for normal time slot in the low chip rate option. It provides the possibility for transmission of TFCI and TPC both in up- and downlink. The SS information will be used only in down link but in order to have the same burst structure for both directions the place of the SS bits are also reserved for up link and may be used in a future enhancement. Taking the mentioned features into consideration the up link multicode reference measurement channel can be the same as the down link 12.2kBit/s reference measurement channel (aligned to 3.84 Mcps TDD Option) with the exception that the SS bits are not used.

The following example will be used from WG1 with 3.4kBit/sec signalling (signalling can be varied between 1.7kBit/sec and 3.4kBit/sec):

NOTE: This example can be applied to multiplexing AMR speech and DCCH.

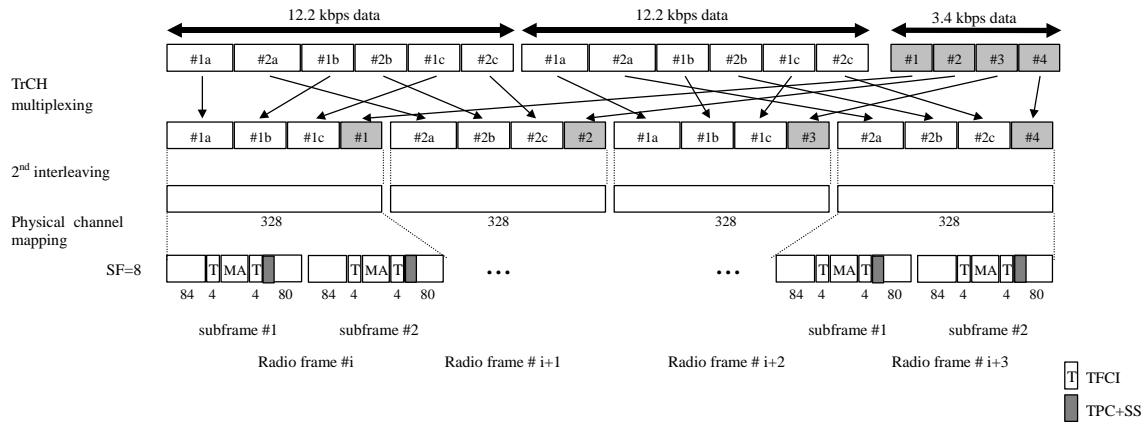

Figure C.0A: Channel coding and multiplexing example for multiplexing of 12.2 kbps data and 3.4 kbps data

Table C.0A: Physical channel parameters for multiplexing of 12.2 kbps data and 3.4 kbps data

| | |
|----------------------|----------------------------|
| Codes and time slots | SF8 x 1 code x 1 time slot |
| TFCI | 16 bits per user |
| TPC + SS | 2 bit + 2bit |

In WG4 the performance simulations have been done with a signalling of 2.4kBit/sec (as an average signalling rate). So the mapping above will be modified for the 2.4kbit/sec signalling rate also.

C.2.1 DL reference measurement channel (12.2 kbps)

Table C.1

| Parameter | Value |
|-----------------------------------------------|------------------------|
| Information data rate | 12.2 kbps |
| RU's allocated | 1TS (2*SF16) = 2RU/5ms |
| Midamble | 144 |
| Interleaving | 20 ms |
| Power control (TPC) | 4 Bit/user/10ms |
| TFCI | 16 Bit/user/10ms |
| Synchronisation Shift (SS) | 4 Bit/user/10ms |
| Inband signalling DCCH | 2.4 kbps |
| Puncturing level at Code rate 1/3: DCH / DCCH | 33% / 33% |

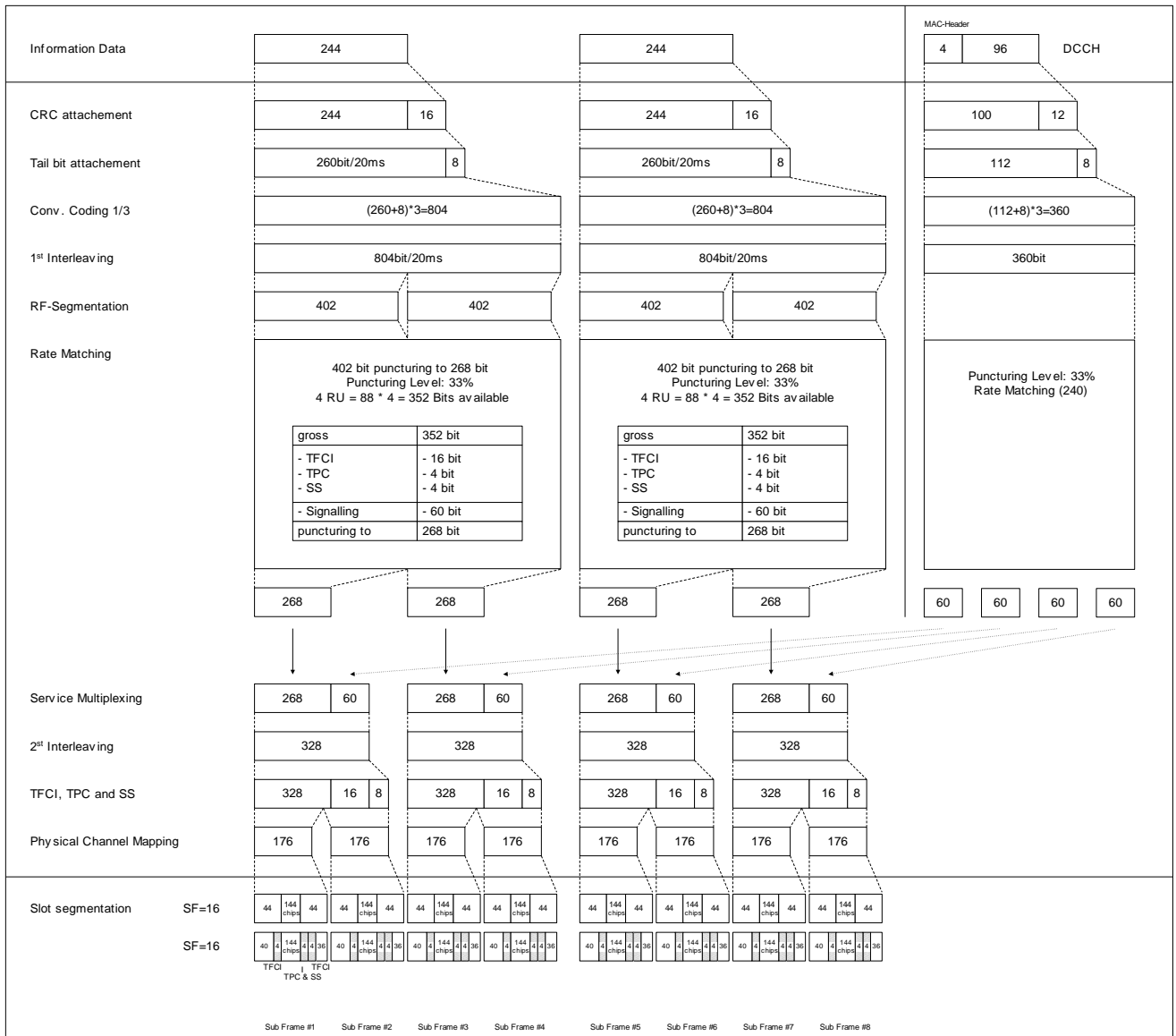

Figure C.1

C.2.2 DL reference measurement channel (64 kbps)

Table C.2

| Parameter | Value |
|---------------------------------------------------|------------------------|
| Information data rate | 64 kbps |
| RU's allocated | 1TS (8*SF16) = 8RU/5ms |
| Midamble | 144 |
| Interleaving | 20 ms |
| Power control (TPC) | 4 Bit/user/10ms |
| TFCI | 16 Bit/user/10ms |
| Synchronisation Shift (SS) | 4 Bit/user/10ms |
| Inband signalling DCCH | 2.4 kbps |
| Puncturing level at Code rate: 1/3 DCH / 1/2 DCCH | 32% / 0 |

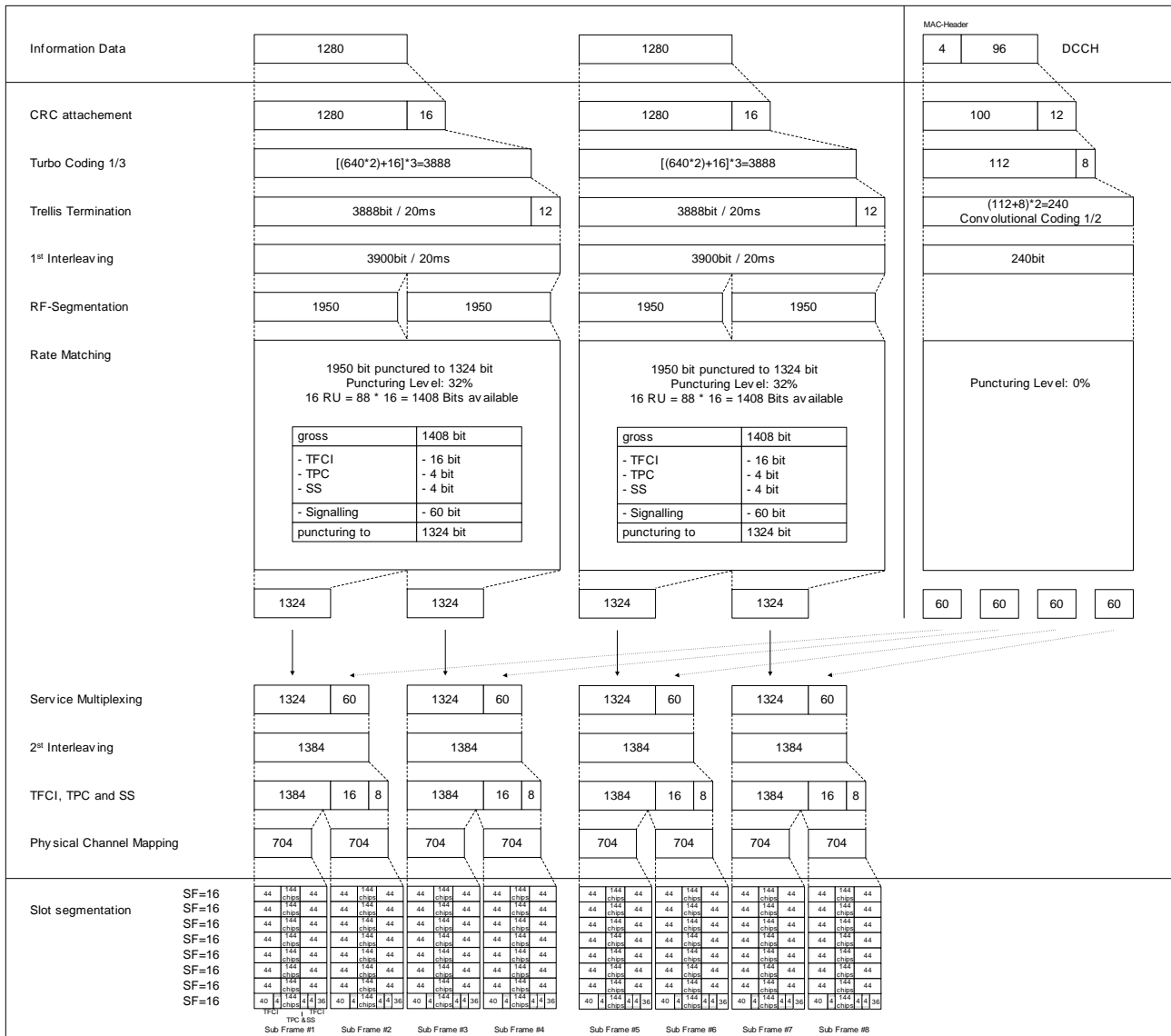

Figure C.2

C.2.3 DL reference measurement channel (144 kbps)

Table C.3

| Parameter | Value |
|---------------------------------------------------|-------------------------|
| Information data rate | 144 kbps |
| RU's allocated | 2TS (8*SF16) = 16RU/5ms |
| Midamble | 144 |
| Interleaving | 20 ms |
| Power control (TPC) | 8 Bit/user/10ms |
| TFCI | 32 Bit/user/10ms |
| Synchronisation Shift (SS) | 8 Bit/user/10ms |
| Inband signalling DCCH | 2.4 kbps |
| Puncturing level at Code rate: 1/3 DCH / 1/2 DCCH | 38% / 7% |

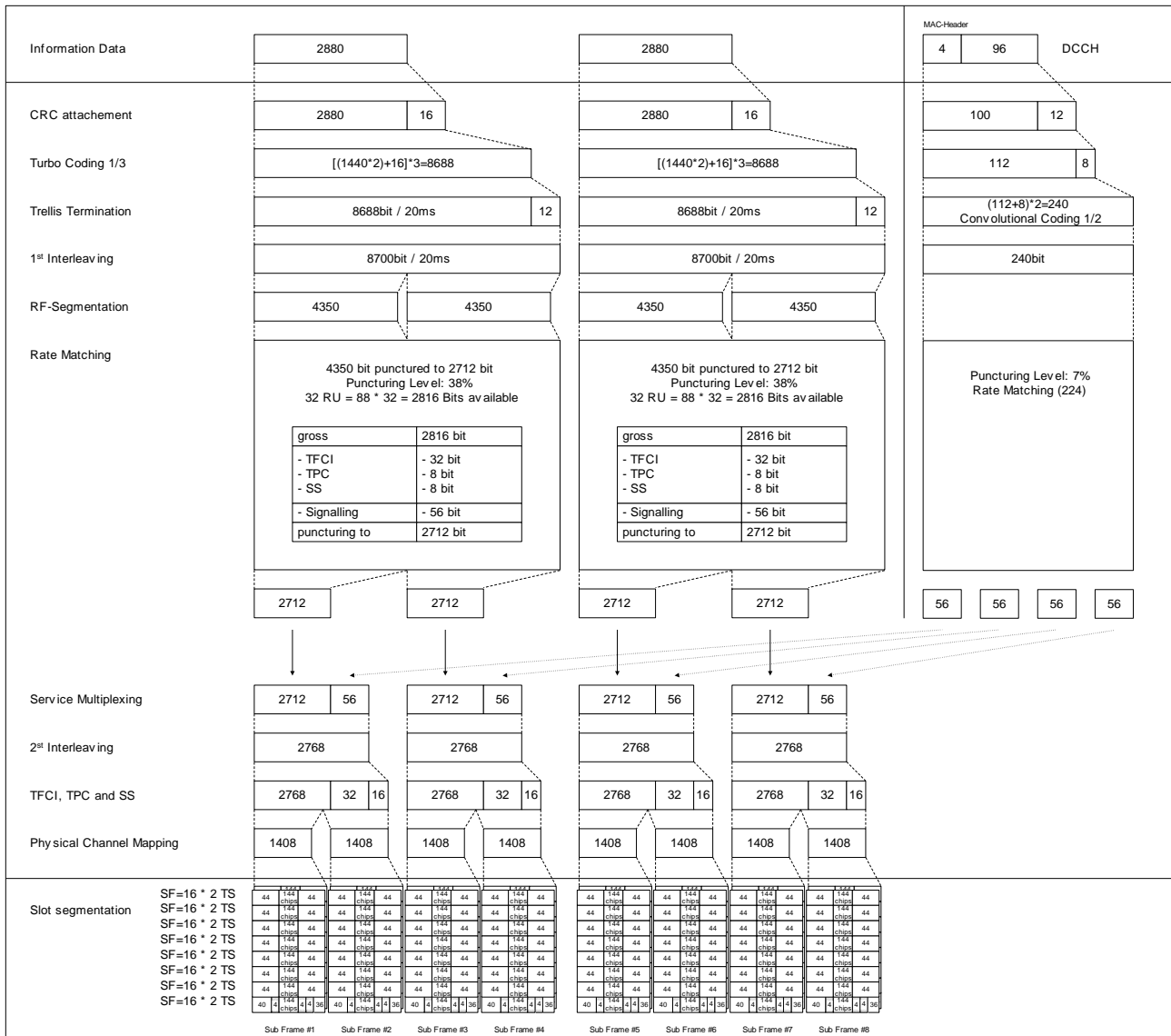

Figure C.3

C.2.4 DL reference measurement channel (384 kbps)

Table C.4

| Parameter | Value |
|---------------------------------------------------|--------------------------|
| Information data rate | 384 kbps |
| RU's allocated | 4TS (10*SF16) = 40RU/5ms |
| Midamble | 144 |
| Interleaving | 20 ms |
| Power control (TPC) | 16 Bit/user/10ms |
| TFCI | 64 Bit/user/10ms |
| Synchronisation Shift (SS) | 16 Bit/user/10ms |
| Inband signalling DCCH | Max.2 kbps |
| Puncturing level at Code rate: 1/3 DCH / 1/2 DCCH | 41% / 12% |

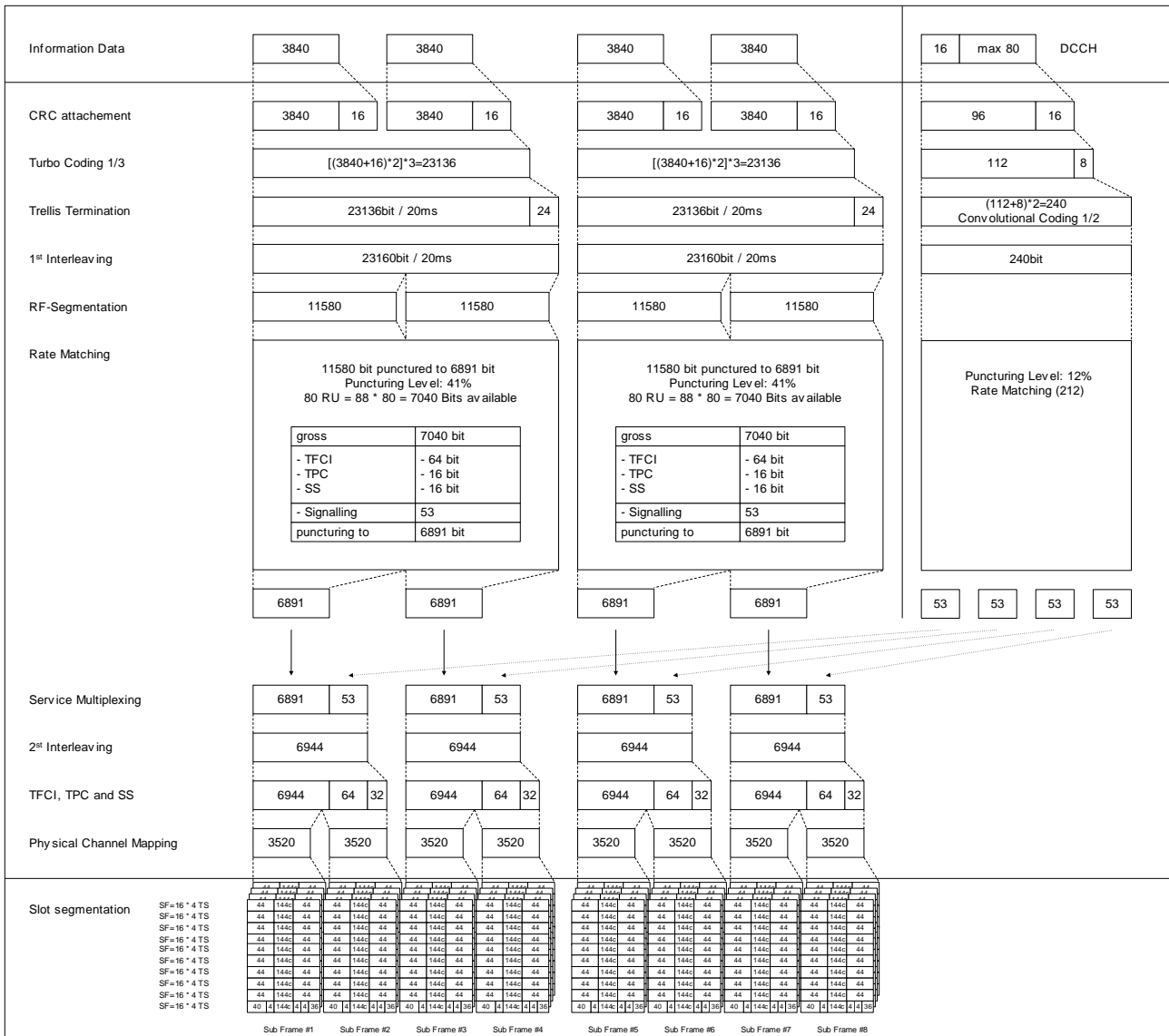

Figure C.4

C.2.4.1 Explanation difference

For the 1.28 Mcps chip rate TDD option, one frame (10ms) consists of two sub-frames(5ms), and one Sub-frame consists of 7 timeslots. The structure of timeslot in 1.28 Mcps chip rate TDD (shown in TR25.928) is different from the structure of timeslot in 3.84 Mcps TDD. So the service mapping of variance data rate of 1.28 Mcps chip rate TDD option is different from that of 3.84 Mcps chip rate TDD option.

C.2.5 BCH reference measurement channel

[mapped to 2 code SF16]

Table C.5

| Parameter | Value |
|------------------------|-----------|
| Information data rate: | 12.3 kbps |
| RU's allocated | 2 RU |
| Midamble | 144 chips |
| Interleaving | 20 ms |
| Power control | 0 bit |
| TFCI | 0 bit |
| Puncturing level | 13% |

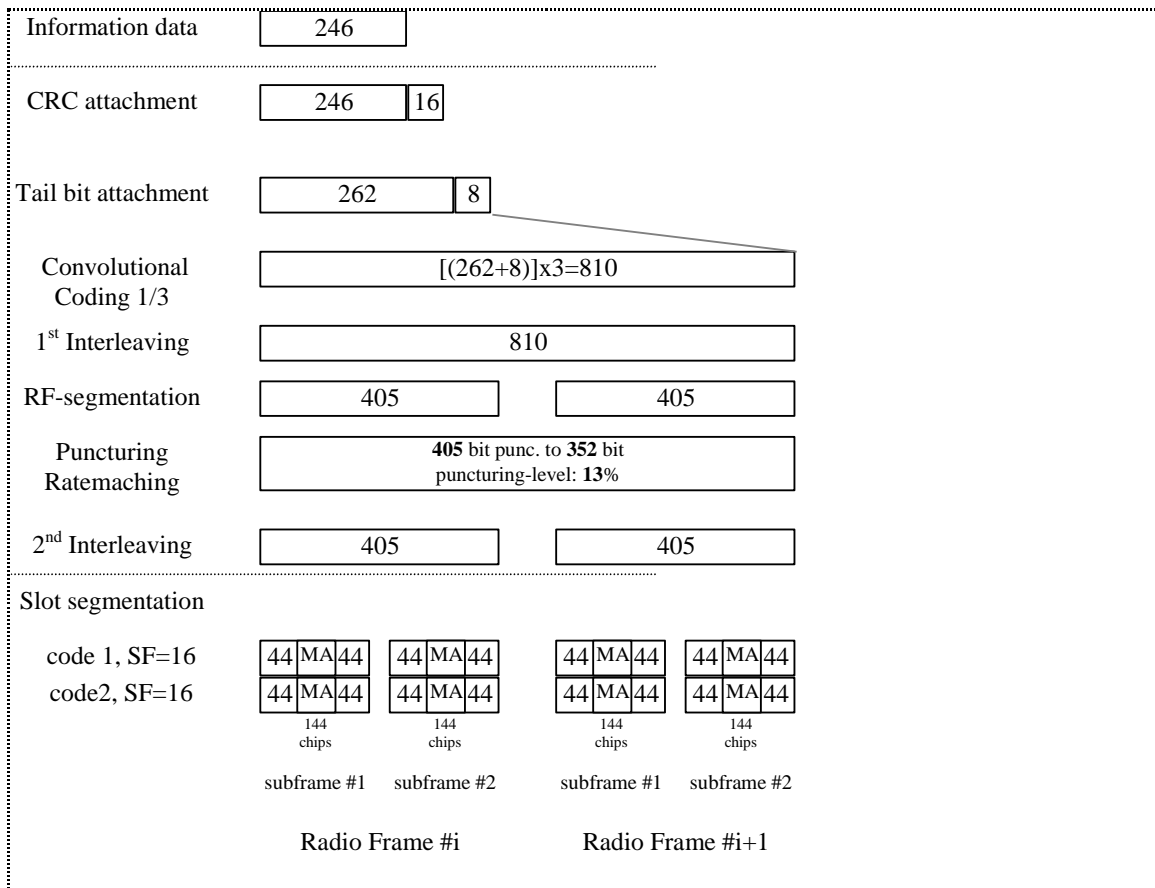

Figure C.5

C.2.5.1 Rationale

A test procedure was introduced for testing the UE BCH decoding performance. In WG1 the following service mapping for BCH was proposed:

Table C.6 : Parameters for BCH

| | |
|----------------------|---------------------------------|
| Transport block size | 246 bits |
| CRC | 16 bits |
| Coding | CC, coding rate = 1/3 |
| TTI | 20 ms |
| Codes and time slots | SF = 16 x 2 codes x 1 time slot |
| TFCI | 0 bit |
| TPC | 0 bit |

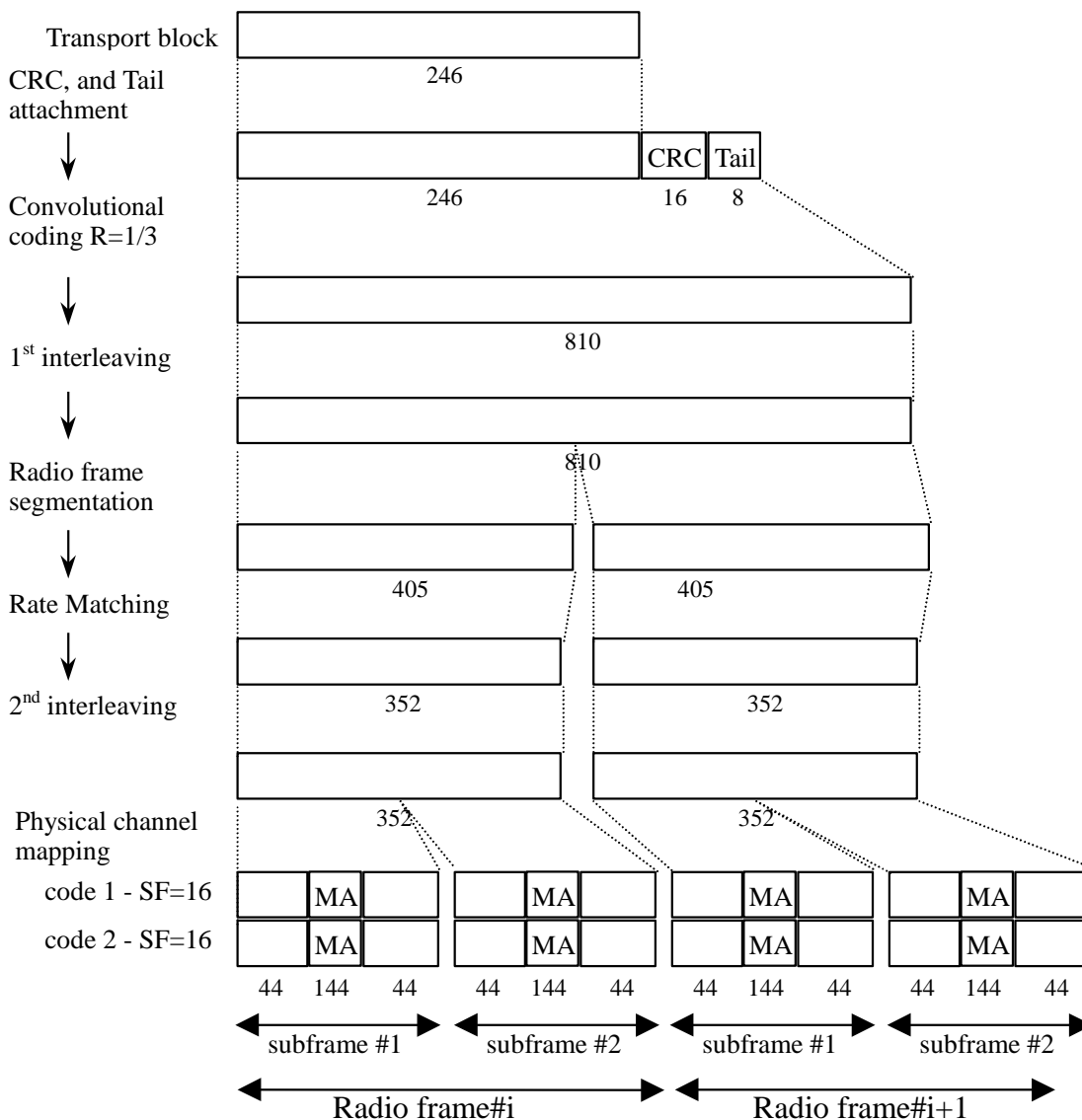

Figure C.6: Channel coding for BCH

According to that service mapping the following BCH reference measurement channel will be proposed.

C.2.6 UL multi code reference measurement channel (12.2 kbps)

Table C.7

| Parameter | Value |
|-----------------------------------------------|------------------------|
| Information data rate | 12.2 kbps |
| RU's allocated | 1TS (2*SF16) = 2RU/5ms |
| Midamble | 144 |
| Interleaving | 20 ms |
| Power control (TPC) | 4 Bit/user/10ms |
| TFCI | 16 Bit/user/10ms |
| 4 Bit reserved for future use (place of SS) | 4 Bit/user/10ms |
| Inband signalling DCCH | 2.4 kbps |
| Puncturing level at Code rate 1/3: DCH / DCCH | 33% / 33% |

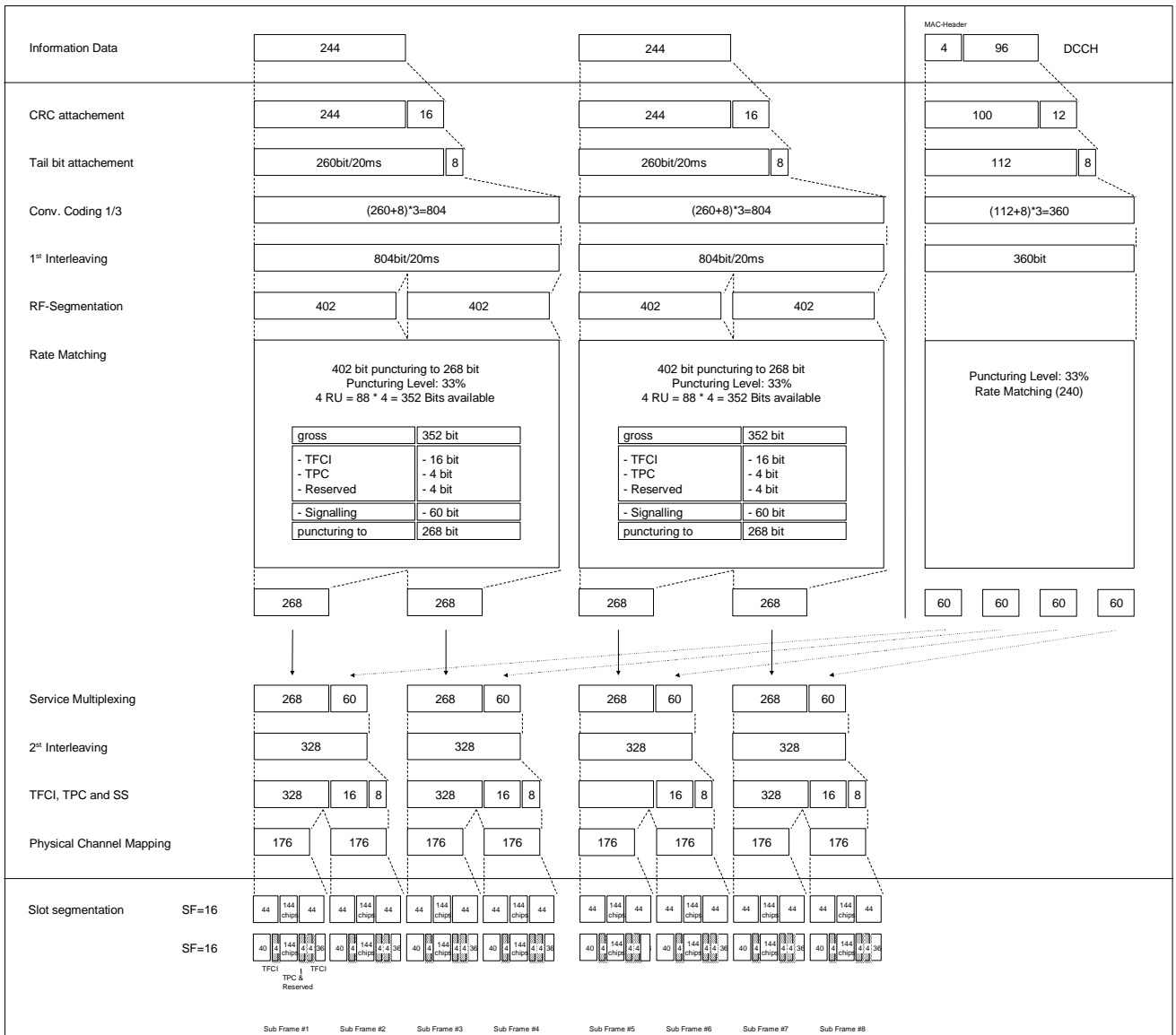

Figure C.7

C.2.6.1 Rationale

A test procedure was introduced for testing the UE PA linearity. For that purpose two codes will be transmitted from the UE and will be analyzed (peak code domain error).

There is only one burst type for normal time slot in the low chip rate option. It provides the possibility for transmission of TFCI and TPC both in up- and downlink. The SS information will be used only in down link but in order to have the same burst structure for both directions the place of the SS bits are also reserved for up link and may be used in a future enhancement. Taking the mentioned features into consideration the up link multicode reference measurement channel can be the same as the down link 12.2kBit/s reference measurement channel (requirement is aligned to 3.84 Mcps TDD option) with the exception that the SS bits are not used.

C.3 Reference measurement channels (Uplink)

C.3.1 UL reference measurement channel (12.2 kbps)

Table C.8

| Parameter | Value |
|-----------------------------------------------|-----------------------|
| Information data rate | 12.2 kbps |
| RU's allocated | 1TS (1*SF8) = 2RU/5ms |
| Midamble | 144 |
| Interleaving | 20 ms |
| Power control (TPC) | 4 Bit/user/10ms |
| TFCI | 16 Bit/user/10ms |
| Synchronisation Shift (SS) | 4 Bit/user/10ms |
| Inband signalling DCCH | 2.4 kbps |
| Puncturing level at Code rate 1/3: DCH / DCCH | 33% / 33% |

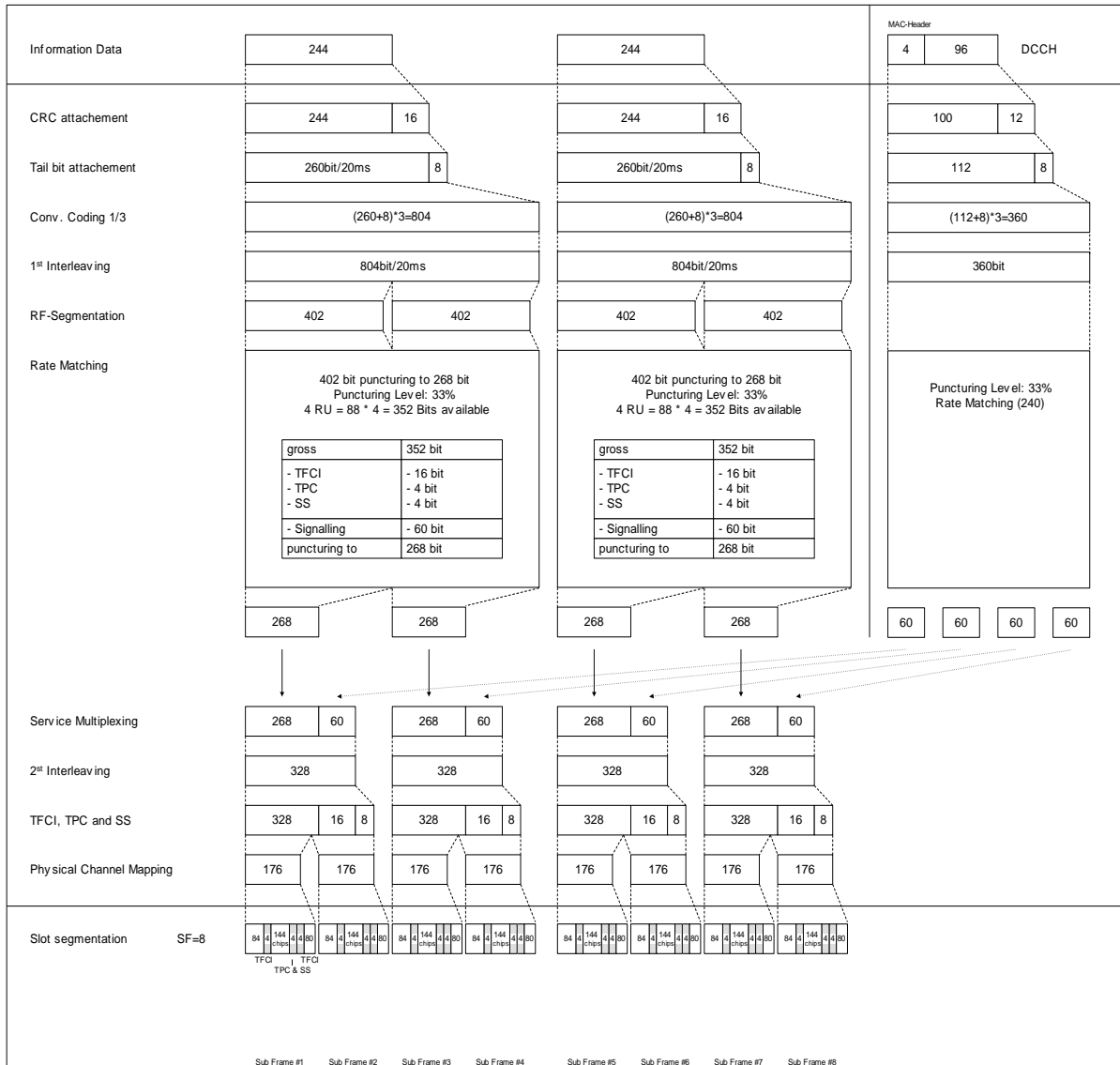

Figure C.8

C.3.2 UL reference measurement channel (64 kbps)

Table C.9

| Parameter | Value |
|---------------------------------------------------|-----------------------|
| Information data rate | 64 kbps |
| RU's allocated | 1TS (1*SF2) = 8RU/5ms |
| Midamble | 144 |
| Interleaving | 20 ms |
| Power control (TPC) | 4 Bit/user/10ms |
| TFCI | 16 Bit/user/10ms |
| Synchronisation Shift (SS) | 4 Bit/user/10ms |
| Inband signalling DCCH | 2.4 kbps |
| Puncturing level at Code rate: 1/3 DCH / 1/2 DCCH | 32% / 0 |

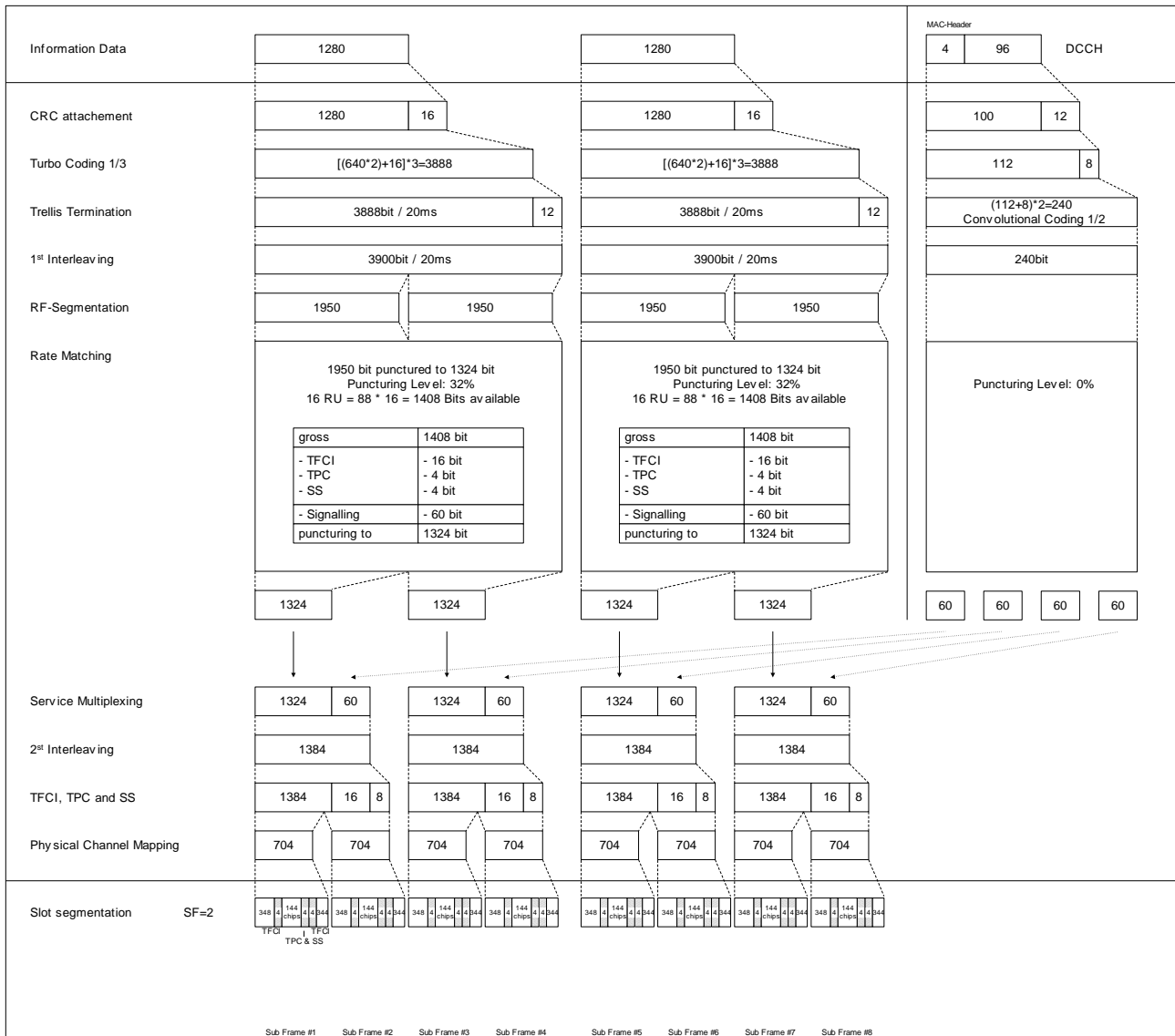

Figure C.9

C.3.3 UL reference measurement channel (144 kbps)

Table C.10

| Parameter | Value |
|---------------------------------------------------|------------------------|
| Information data rate | 144 kbps |
| RU's allocated | 2TS (1*SF2) = 16RU/5ms |
| Midamble | 144 |
| Interleaving | 20 ms |
| Power control (TPC) | 8 Bit/user/10ms |
| TFCI | 32 Bit/user/10ms |
| Synchronisation Shift (SS) | 8 Bit/user/10ms |
| Inband signalling DCCH | 2.4 kbps |
| Puncturing level at Code rate: 1/3 DCH / 1/2 DCCH | 38% / 7% |

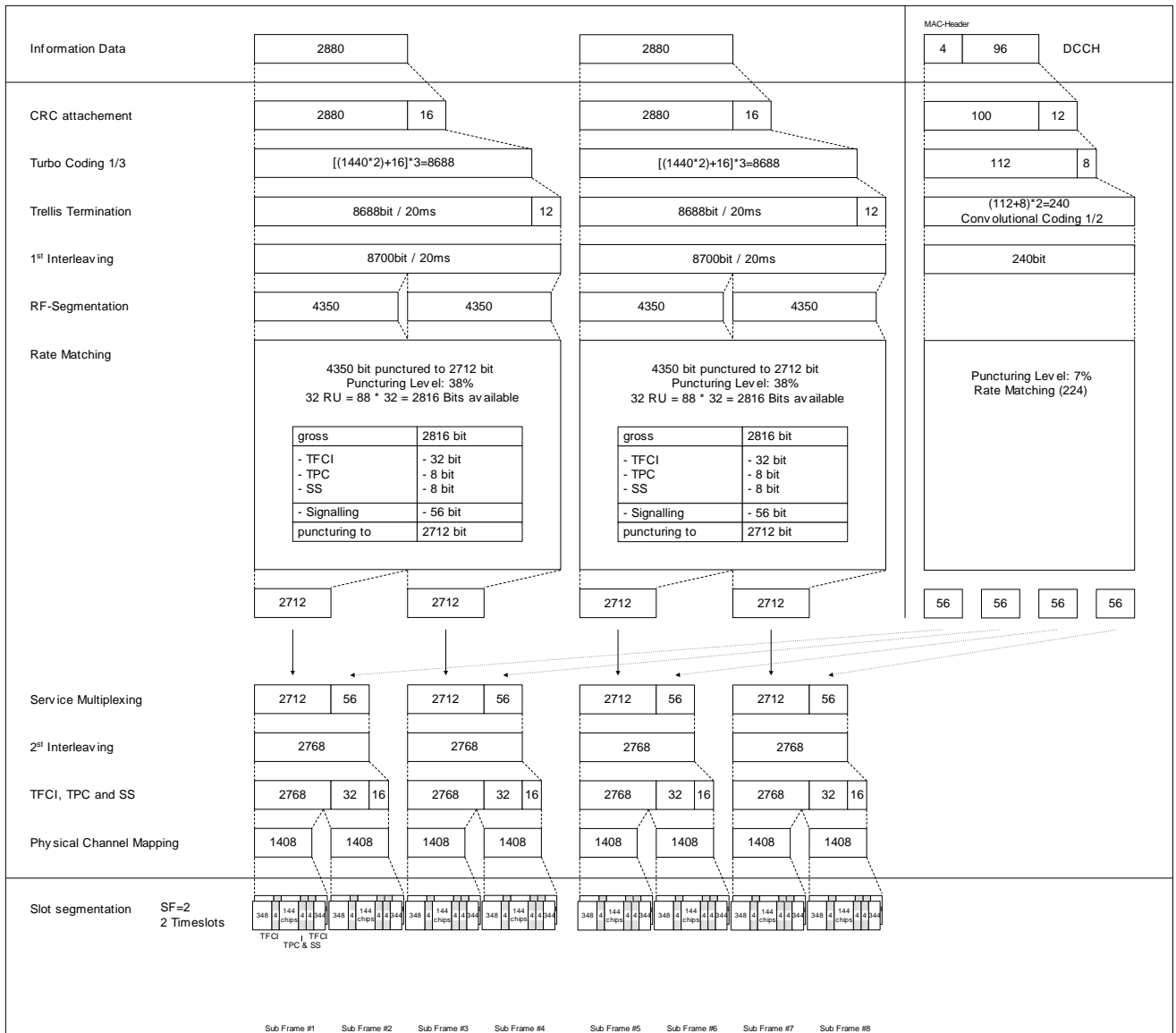

Figure C.10

C.3.4 UL reference measurement channel (384 kbps)

Table C.11

| Parameter | Value |
|---------------------------------------------------|--------------------------------|
| Information data rate | 384 kbps |
| RU's allocated | 4TS (1*SF2 + 1*SF8) = 40RU/5ms |
| Midamble | 144 |
| Interleaving | 20 ms |
| Power control (TPC) | 16 Bit/user/10ms |
| TFCI | 64 Bit/user/10ms |
| Synchronisation Shift (SS) | 16 Bit/user/10ms |
| Inband signalling DCCH | Max.2 kbps |
| Puncturing level at Code rate: 1/3 DCH / 1/2 DCCH | 41% / 12% |

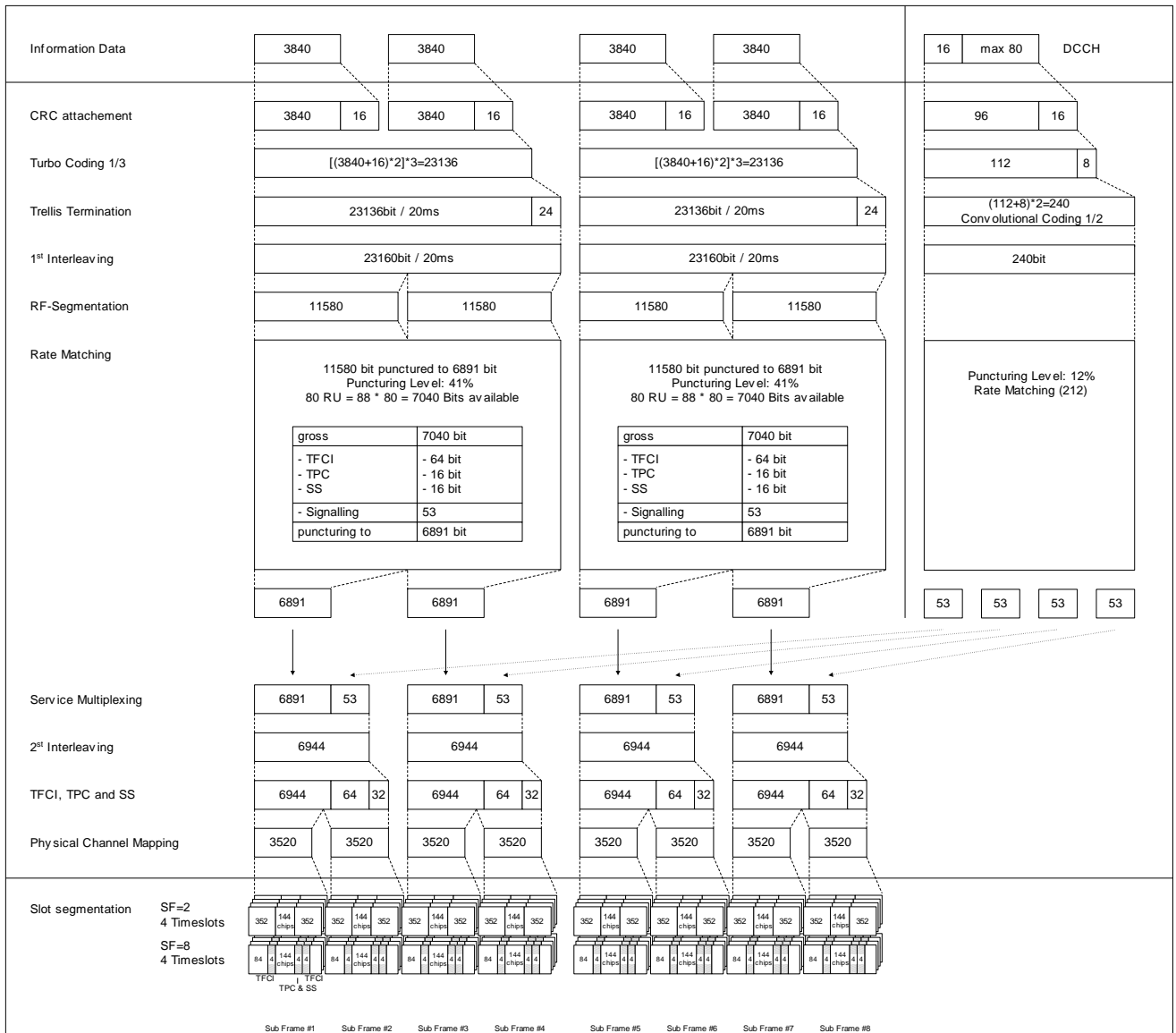

Figure C.11

C.3.5 RACH reference measurement channel

Table C.12

| Parameter | Value |
|---------------------------------------------------------------------------------------------------------------------------|--------------------------------------------------------|
| Information data rate: $N_{RACH} = \frac{88 * \frac{16}{SF} \left(\frac{N_{RM}}{100} + 1 \right) - 8}{B_{RACH}} - 16$ | $B_{RACH} = 1$ CRC length = 16 Tail Bits = 8 |
| SF16 (RU's allocated:1): 0% puncturing rate at CR=1/2 ~10% puncturing rate at CR=1/2 | 20 bits per frame and TB 24 bits per frame and TB |
| SF8 (RU's allocated:2): 0% puncturing rate at CR=1/2 ~10% puncturing rate at CR=1/2 | 64 bits per frame and TB 73 bits per frame and TB |
| SF4 (RU's allocated:4): 0% puncturing rate at CR=1/2 ~10% puncturing rate at CR=1/2 | 152 bits per frame and TB 170 bits per frame and TB |
| TTI | 5msec |
| Midamble | 144 chips |
| Power control | 0 bit |
| TFCI | 0 bit |

N_{RACH} = number of bits per TB

B_{RACH} = number of TBs

N_{RM} =puncturing rate

C.3.5.1 RACH mapped to 1 code SF16

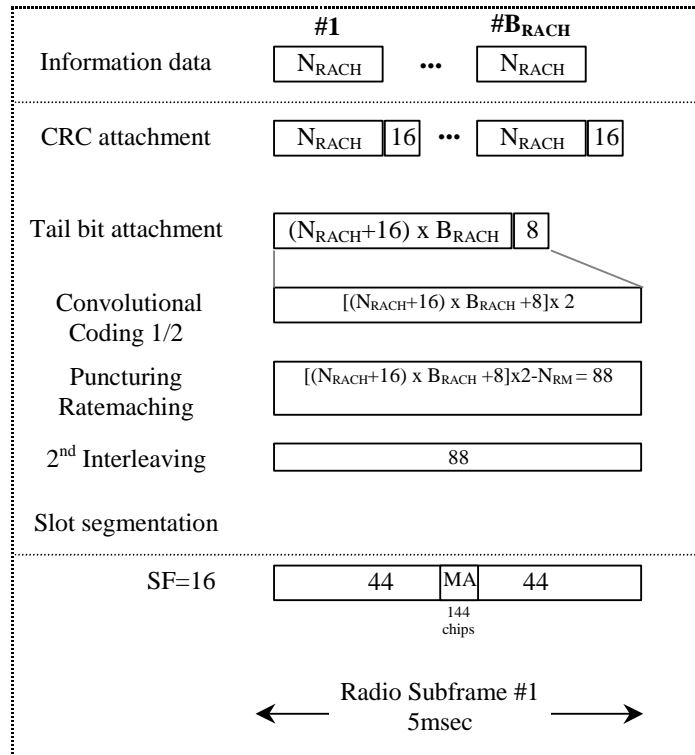

Figure C.12

C.3.5.2 RACH mapped to 1 code SF8

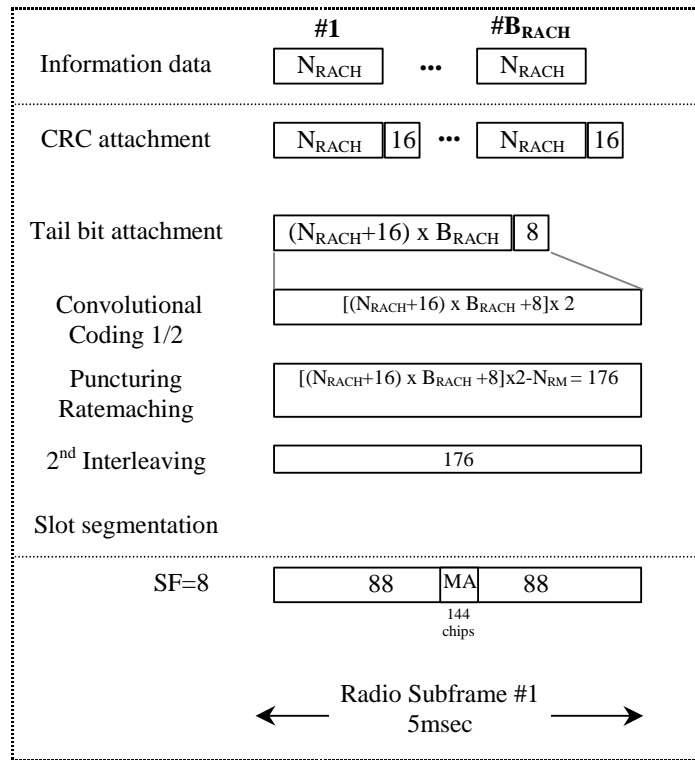

Figure C.13

C.3.5.3 RACH mapped to 1 code SF4

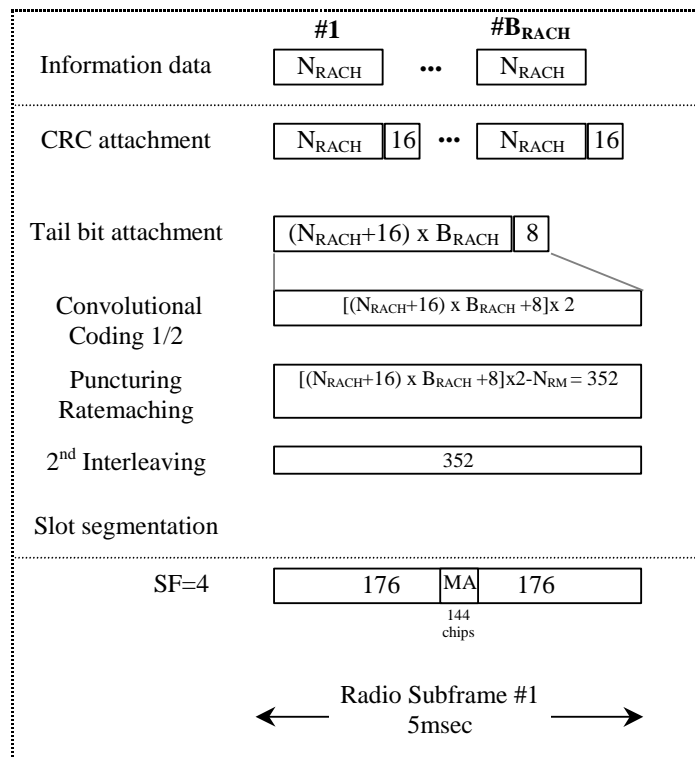

Figure C.14

C.3.5.3.1 Explanation difference

For the 1.28 Mcps chip rate TDD option, one frame (10ms) consists of two sub-frames(5ms), and one Sub-frame consists of 7 timeslots. The structure of timeslot in 1.28 Mcps chip rate TDD (shown inTR25.928) is different from the structure of timeslot in 3.84 Mcps TDD. So the service mapping of variance data rate of 1.28 Mcps chip rate TDD option is different from that of 3.84 Mcps chip rate TDD option.

Annex D (informative): Propagation conditions

D.1 Static Propagation conditions

The propagation for the static performance measurement is an Additive White Gaussian Noise (AWGN) environment. No fading and multi-path exist for the propagation model.

D.2 Multi-path fading propagation conditions

Table D.1 shows propagation conditions that are used for the performance measurements in multi-path fading environment. All taps have classical Doppler spectrum.

Table D.1: Propagation Conditions for Multi-Path Fading Environments

| Case 1, speed 3km/h | | Case 2, speed 3km/h | | Case 3, speed 120km/h | |
|---------------------|--------------------|---------------------|--------------------|-----------------------|--------------------|
| Relative Delay [ns] | Average Power [dB] | Relative Delay [ns] | Average Power [dB] | Relative Delay [ns] | Average Power [dB] |
| 0 | 0 | 0 | 0 | 0 | 0 |
| 2928 | -10 | 2928 | 0 | 781 | -3 |
| | | 12000 | 0 | 1563 | -6 |
| | | | | 2344 | -9 |

D.2.1 Rationale

The channel estimation can only resolve paths which are separated by at least one chip in delay. Otherwise the paths fall into the same tap. Even though this happens in realistic environments, it is not useful to base the propagation models for the performance requirements on a scenario with a delay spread of less than 1 chip, because the baseband is not tested in this case. Therefore, it is proposed to keep the same delay for the path in units of chips for the 1.28 Mcps chip rate TDD-mode as for the 3.84 Mcps chip rate TDD-mode. The tap delays in units of time are changed accordingly to take into account the difference in the chip rate. Due to the request to have the same maximum delay spread for 1.28 Mcps chip rate TDD as for 3.84 Mcps chip rate TDD, the delay spread of tap 3rd for the case 2 propagation conditions is set to 12 ms.

Annex E (informative): Environmental conditions

E.1 General

This normative annex specifies the environmental requirements of the UE. Within these limits the requirements of this specifications shall be fulfilled.

E.2 Environmental requirements for the UE

The requirements in this clause apply to all types of UE(s)

E.2.1 Temperature

The UE shall fulfil all the requirements in the full temperature range of:

Table E.1

| | |
|---------------|-----------------------------------------------------------------|
| +15°C – +35°C | for normal conditions (with relative humidity of 25 % to 75 %); |
| -10°C - +55°C | for extreme conditions (see IEC publications 68-2-1 and 68-2-2) |

Outside this temperature range the UE, if powered on, shall not make ineffective use of the radio frequency spectrum. In no case shall the UE exceed the transmitted levels as defined in TR25.945 UE Section for extreme operation.

E.2.2 Voltage

The UE shall fulfil all the requirements in the full voltage range, i.e. the voltage range between the extreme voltages.

The manufacturer shall declare the lower and higher extreme voltages and the approximate shutdown voltage. For the equipment that can be operated from one or more of the power sources listed below, the lower extreme voltage shall not be higher, and the higher extreme voltage shall not be lower than that specified below.

Table E.2

| Power source | Lower extreme voltage | Higher extreme voltage | Normal conditions voltage |
|-----------------------------------------------|-----------------------|------------------------|---------------------------|
| AC mains | 0,9 * nominal | 1,1 * nominal | nominal |
| Regulated lead acid battery | 0,9 * nominal | 1,3 * nominal | 1,1 * nominal |
| Non regulated batteries: Leclanché/lithium | 0,85 * nominal | Nominal | Nominal |
| Mercury/nickel cadmium | 0,90 * nominal | Nominal | Nominal |

Outside this voltage range the UE if powered on, shall not make ineffective use of the radio frequency spectrum. In no case shall the UE exceed the transmitted levels as defined in TR25.945 UE section for extreme operation. In particular, the UE shall inhibit all RF transmissions when the power supply voltage is below the manufacturer declared shutdown voltage.

E.2.3 Vibration

The UE shall fulfil all the requirements when vibrated at the following frequency/amplitudes:

Table E.3

| Frequency | ASD (Acceleration Spectral Density) random vibration |
|-----------------|-----------------------------------------------------------------------|
| 5 Hz to 20 Hz | 0,96 m ² /s ³ |
| 20 Hz to 500 Hz | 0,96 m ² /s ³ at 20 Hz, thereafter -3 dB/Octave |

Outside the specified frequency range the UE, if powered on, shall not make ineffective use of the radio frequency spectrum. In no case shall the UE exceed the transmitted levels as defined in TR25.945 UE section for extreme operation.

E.2.4 Rationale

The environmental conditions of UE specification is kept in line with 3.84 Mcps TDD, because these specification do not consider the bandwidth of the signal nor any other difference between 3.84 Mcps TDD and 1.28 Mcps TDD.

Annex F (informative): Terminal capabilities (TDD)

This section provides the UE capabilities related to this report.

Notes: This section shall be aligned with TS 25.306 [15] regarding TDD RF parameters. These RF UE Radio Access capabilities represent options in the UE, that require signalling to the network.

Table F.1 provides the list of UE radio access capability parameters and possible values for this report.

Table F.1: RF UE Radio Access Capabilities

| UE radio access capability parameter | Value range |
|---------------------------------------------------|----------------------------------------------------------|
| UE power class (TR25.945 section 5.2.2.1) | 2, 3 NOTE: Only power classes 2 and 3 are part of R99 |
| Radio frequency bands (TR25.945 section 5.1.2) | a), b), c), a+b), a+c), a+b+c) |
| Chip rate capability (25.945) | 1.28 Mcps |

This section shall be aligned with TS 25.306 now, which includes the related chapters discussing both 3.84 Mcps TDD Option and 1.28 Mcps TDD Option UE Radio Access Capabilities. Therefore it is proposed to change some word descriptions in TR25.945.

Annex G (informative): Methods of measurement

G.1 Emission

G.1.1 Methods of measurement and limits for EMC emissions

Common with 3.84 Mcps Chip rate TDD option.

G.1.2 Test configurations

Common with 3.84 Mcps Chip rate TDD option.

G.1.3 Radiated spurious emission from Base station and ancillary equipment

G.1.3.1 Radiated spurious emission, Base stations

G.1.3.1.1 Definition

Common with 3.84 Mcps Chip rate TDD option.

G.1.3.1.2 Test method

- a) Common with 3.84 Mcps TDD option.
- b) The BS shall transmit with maximum power declared by the manufacturer with all transmitters active. Set the base station to transmit a signal as stated in Table 8.3.2-1 of TR25.945.
- c) The received power shall be measured over the frequency range 30 MHz to 12.75 GHz, excluding 4MHz below the first carrier frequency to 4 MHz above the last carrier frequency used. The measurement bandwidth shall be 100 kHz between 30 MHz and 1 GHz and 1 MHz above 1 GHz as given in ITU-R SM.329 [16]. The video bandwidth shall be approximately three times the resolution bandwidth. If this video bandwidth is not available on the measuring receiver, it shall be the maximum available and at least 1 MHz. At each frequency at which a component is detected, the maximum effective radiated power of that component shall be determined, as described in step a).

G.1.3.1.2.1 Explanation difference

To identify responses on receivers or duplex transceivers occurring during the test at discrete frequencies which are narrow band responses, the test shall be repeated with the unwanted signal frequency increased, and then decreased by several bandwidths.

Due to the different bandwidth of the low chip rate TDD option from that of the high chip rate TDD option, the frequency increased and/or decreased is changed from 10MHz to 3.2MHz, from 12.5MHz to 4MHz.

G.1.3.1.3 Limits

Common with 3.84 Mcps Chip rate TDD option.

G.1.3.2 Radiated spurious emission, Ancillary equipment

Common with 3.84 Mcps Chip rate TDD option.

G.1.4 Conducted emission DC power input/output port

Common with 3.84 Mcps Chip rate TDD option.

G.1.5 Conducted emissions, AC mains power input/output port

Common with 3.84 Mcps Chip rate TDD option.

G.1.6 Harmonic Current emissions (AC mains input port)

Common with 3.84 Mcps Chip rate TDD option.

G.1.7 Voltage fluctuations and flicker (AC mains input port)

Common with 3.84 Mcps Chip rate TDD option.

G.2 Immunity

Common with 3.84 Mcps Chip rate TDD option.

Annex H (informative): Global in-channel Tx test

H.1 General

Description is common with 3.84 Mcps TDD option.

H.2 Definition of the process

H.2.1 Basic principle

Description is common with 3.84 Mcps TDD option.

H.2.2 Output signal of the Tx under test

Description is common with 3.84 Mcps TDD option

H.2.3 Reference signal

Description is common with 3.84 Mcps TDD option

H.2.4 Classification of measurement results

Description is common with 3.84 Mcps

H.2.5 Process definition to achieve results of type “deviation”

Description is common with 3.84 Mcps TDD option.

H.2.6 Process definition to achieve results of type “residual”

Description is common with 3.84 Mcps TDD option.

H.2.7 Error Vector Magnitude (EVM)

Description is common with 3.84 Mcps TDD option.

H.2.8 Peak Code Domain Error (PCDE)

Description is common with 3.84 Mcps TDD option.

H.3 Applications

This process may be applied in the measurements defined in the following subclauses:

8.3.3 Frequency Stability

| | |
|-----------|---------------------------------------------|
| 8.3.4 | Output Power Dynamics |
| 8.3.4.2 | Power control steps |
| 8.3.4.3 | Power control dynamic range |
| 8.3.4.4 | Minimum transmit power |
| 8.3.4.5 | Primary CCPCH power |
| 8.3.6.2.2 | Adjacent Channel Leakage power Ratio (ACLR) |
| 8.3.8 | Transmit Modulation |
| 8.3.8.1 | Modulation accuracy |
| 8.3.8.2 | Peak Code Domain Error |

H.4 Notes

- NOTE: Symbol length
Description is common with 3.84 Mcps TDD option
- NOTE: Deviation
Description is common with 3.84 Mcps TDD option.
- NOTE: Residual
Description is common with 3.84 Mcps TDD option.
- NOTE: Scrambling code
Description is common with 3.84Mpcs TDD option.
- NOTE: TDD
Description is common with 3.84 Mcps TDD option.

H.5 Rationale

The global in-channel Tx test enables the measurement of all relevant parameters that describe the in-channel quality of the output signal of the Tx under test in a single measurement process, not only FDD and all options of TDD.

Annex I (informative): Change History

Table I.1: Change History

| TSG/ Date | Doc | CR | R | Title | Cat | Curr | New | Work Item |
|----------------------|------------|-----------|----------|---------------------------------------------------|------------|-------------|------------|----------------------|
| RP-15 | | | | Rel-5 version created by TSG RAN decision, no CRs | | | 5.0.0 | |
| RP-23 | RP-040038 | 0002 | | Correction of references to ITU recommendations | F | 5.0.0 | 5.1.0 | TEI5 |
| RP-35 | RP-070081 | 0004 | | CR on Changing SEM for LCR TDD | F | 5.1.0 | 5.2.0 | TEI5 |