

# 3GPP TR 25.933 V5.4.0 (2003-12)

---

*Technical Report*

## **3rd Generation Partnership Project; Technical Specification Group Radio Access Network; IP transport in UTRAN (Release 5)**



The present document has been developed within the 3<sup>rd</sup> Generation Partnership Project (3GPP<sup>TM</sup>) and may be further elaborated for the purposes of 3GPP.

The present document has not been subject to any approval process by the 3GPP Organizational Partners and shall not be implemented. This Specification is provided for future development work within 3GPP only. The Organizational Partners accept no liability for any use of this Specification. Specifications and reports for implementation of the 3GPP<sup>TM</sup> system should be obtained via the 3GPP Organizational Partners' Publications Offices.

---

Keywords

---

UMTS, radio, IP

**3GPP**

Postal address

---

3GPP support office address

---

650 Route des Lucioles - Sophia Antipolis  
Valbonne - FRANCE  
Tel.: +33 4 92 94 42 00 Fax: +33 4 93 65 47 16

Internet

---

<http://www.3gpp.org>

---

**Copyright Notification**

---

No part may be reproduced except as authorized by written permission.  
The copyright and the foregoing restriction extend to reproduction in all media.

© 2004, 3GPP Organizational Partners (ARIB, CCSA, ETSI, T1, TTA, TTC).  
All rights reserved.

---

# Contents

Foreword .....	10
1 Scope .....	11
2 References.....	11
3 Definitions, symbols and abbreviations .....	14
3.1 Definitions.....	14
3.2 Symbols .....	14
3.3 Abbreviations .....	14
4 Introduction .....	15
4.1 Task Description .....	15
4.2 Rationale for IP Transport.....	15
5 Requirements.....	16
5.1 General requirements .....	16
5.2 Independence to Radio Network Layer.....	16
5.3 Services required by the upper layers of user planes of Iu .....	16
5.4 Services required by the upper layers of user planes of Iur and Iub .....	17
5.5 Coexistence of the two transport options.....	17
5.6 Quality of Service .....	17
5.7 Efficient utilization of transport resources .....	18
5.8 Layer 2/Layer 1 independence .....	18
5.9 Transport Bearer Identification .....	18
5.10 Transport Network Architecture and Routing .....	18
5.10.1 Network elements.....	18
5.11 Radio Network Signalling Bearer.....	18
6 Study Areas.....	19
6.1 External standardization .....	19
6.2 User plane proposed solutions .....	19
6.2.1 CIP solution .....	19
6.2.1.1 CIP Container.....	19
6.2.1.2 CIP Packets.....	19
6.2.1.2.1 Segmentation and Re-assembly .....	19
6.2.1.2.2 CIP Packet Header Format .....	20
6.2.1.2.3 The CIP Packet Header Fields in Detail.....	20
6.2.1.2.4 Discussion of the CIP Packet Header Field Sizes .....	21
6.2.2 LIPE solution.....	21
6.2.2.1 Details of Multiplexed Header .....	22
6.2.2.2 Basic Header.....	22
6.2.2.3 Extensions.....	22
6.2.3 PPP-MUX based solution .....	23
6.2.3.1 PPP Multiplexed Frame Option Over HDLC .....	23
6.2.3.2 PPP Multiplexed Frame Option Over ATM/AAL5.....	24
6.2.3.3 PPP Multiplexed Frame Option Over L2TP Tunnel (TCRTP) .....	25
6.2.4 MPLS solution .....	26
6.2.4.1 MPLS General Description.....	26
6.2.4.2 Routing with MPLS .....	26
6.2.4.3 Support for QoS requirements.....	27
6.2.4.4 Efficient, QoS-enabled transmission over routed domains with MPLS .....	27
6.2.4.5 Efficient transmission over narrowband (point-to-point) links with MPLS .....	29
6.2.4.5.1 MPLS Header Compression "Session Negotiation" .....	29
6.2.4.5.1.1 Using RSVP-TE to negotiate "MPLS Simple Header Compression".....	30
6.2.4.5.1.2 Using LDP signalling for "MPLS Simple Header Compression" session negotiation .....	30
6.2.4.5.2 Handling of large packets over narrowband links .....	30
6.2.5 AAL2 based solution .....	31
6.2.6 Usage of UDP Lite for IP UTRAN .....	31

6.2.6.1	Background.....	31
6.2.6.2	UDP Lite .....	31
6.3	QoS.....	32
6.3.1	Fragmentation .....	32
6.3.1.1	General .....	32
6.3.1.2	IP fragmentation .....	33
6.3.1.3	Fragmentation to facilitate delay sensitive traffic .....	33
6.3.1.4	Application level fragmentation.....	33
6.3.1.5	Layer 2 fragmentation solution.....	34
6.3.2	Sequence information .....	34
6.3.3	Error detection.....	34
6.3.4	Flow Classification in IP Networks.....	34
6.3.4.1	Classification based on RNL information .....	34
6.3.4.2	Classification based on TNL information .....	35
6.3.5	Classification Configuration.....	35
6.3.5.1	Transport bearer based classification .....	35
6.3.5.2	Packet per packet classification .....	35
6.3.6	UTRAN Hop-by-Hop QoS Approach.....	36
6.3.7	UTRAN End-to-End QoS Approach .....	36
6.4	Transport network bandwidth utilization.....	36
6.4.1	General issues.....	37
6.4.1.1	Multiplexing .....	37
6.4.1.1.1	Location of multiplexing in transport network .....	37
6.4.1.1.1.1	Scenario 1: .....	37
6.4.1.1.1.2	Scenario 2: .....	38
6.4.1.1.1.3	Scenario 3: .....	38
6.4.1.2	Resource Management .....	39
6.4.1.3	Header Compression Techniques .....	39
6.4.1.3.1	Technical evaluation .....	39
6.4.1.3.1.1	Use of Differential Coding .....	40
6.4.1.3.1.2	Comparison.....	40
6.4.1.3.2	UTRAN Evaluation .....	40
6.4.1.3.3	Use of Negotiation .....	40
6.4.2	Solution Comparison data.....	40
6.5	User plane transport signalling.....	41
6.5.1	Solution without ALCAP .....	41
6.5.1.1	Principle .....	41
6.5.1.2	Solution without using additional RNL Parameters .....	42
6.5.1.2.1	On Iub - Iur.....	42
6.5.1.2.2	Inter-working on Iu.....	43
6.5.1.3	Solution with higher flexibility and complexity using additional RNL parameters .....	44
6.5.1.4	Provisioning and Dynamic Selection of the Transport Option.....	44
6.5.1.4.1	On Iub.....	44
6.5.1.4.2	Inter-working on Iu .....	44
6.5.1.4.3	Interworking on Iur .....	45
6.5.1.4.3.1	Provisioning of transport capabilities .....	45
6.5.1.4.3.2	Indicate dynamically in a signaling message the IP Transport Option Availability or ATM Preference .....	45
6.5.1.4.3.3	Benefits .....	45
6.5.1.4.3.4	Drawbacks .....	45
6.5.2	LIPE solution.....	46
6.5.2.1	Alternative I Solution: .....	46
6.5.2.1.1	LIPE Signalling Channel .....	47
6.5.2.1.2	Tunnel Setup Procedure .....	47
6.5.2.1.3	Connection Set up Procedure.....	47
6.5.2.1.4	Tunnel tear down.....	47
6.5.2.1.5	Connection tear down.....	48
6.5.2.2	Alternative II Solution: .....	48
6.6	Layer 1 and layer 2 independence.....	48
6.6.1	Options for L2 specification .....	48
6.6.1.1	General .....	48
6.6.1.2	L2 not standardized.....	48

6.6.1.3	L2 standardized .....	49
6.7	Radio Network Signalling bearer .....	49
6.7.1	Iub RNL signalling bearer .....	49
6.7.1.1	SCTP characteristics .....	49
6.7.1.2	Proposal 1 .....	49
6.7.1.3	Proposal 2 .....	50
6.7.1.4	Use of SCTP .....	50
6.7.2	RNSAP Signalling .....	51
6.7.3	RANAP Signalling .....	51
6.7.4	PCAP signalling .....	52
6.7.5	SCCP/M3UA versus SUA .....	52
6.7.6	Interworking of SCCP/M3UA and SUA .....	53
6.7.6.1	Interworking in native SS7 networks .....	53
6.7.6.2	Interworking in SS7 and SigTran Networks .....	54
6.7.6.3	Interworking in UTRAN .....	58
6.7.6.4	SCCP and SUA interworking in detail .....	59
6.7.6.4.1	Establishment of SUA connectivity .....	59
6.7.6.4.2	SEP Failover .....	60
6.7.6.4.3	Successful ASP Failover scenario .....	60
6.7.6.4.4	Message mapping between SCCP and SUA .....	61
6.7.6.5	Conclusions .....	62
6.7.7	Iub Signalling Bearer Comparison Data .....	62
6.7.7.1	Comparison TCP, UDP, SCTP .....	62
6.7.7.1.1	User service .....	62
6.7.7.1.2	Reliability .....	62
6.7.7.1.3	Availability .....	62
6.7.7.1.4	Defence/Security .....	63
6.7.7.1.5	Performance .....	63
6.7.7.1.6	RNL changes .....	64
6.7.7.1.7	Implementation Difficulty .....	64
6.7.7.1.8	Maturity .....	64
6.7.7.1.9	Interoperability .....	64
6.7.7.1.10	Operational aspects .....	64
6.7.7.2	Summary .....	65
6.7.8	Reference Architecture for ENUM based Services .....	65
6.7.8.1	Key requirements/assumptions of the mobility services using ENUM .....	65
6.7.8.2	Some definitions .....	66
6.7.8.3	System solution based on ENUM .....	67
6.7.8.4	Service discovery/IP address retrieval of end service nodes .....	67
6.8	Addressing .....	69
6.8.1	General addressing requirements .....	69
6.8.2	Bearer addressing solutions .....	70
6.8.2.1	Destination IP addresses and destination UDP ports as connection identifiers .....	70
6.9	IP transport and routing architecture aspects .....	71
6.9.1	Flexibility of IP architectures .....	71
6.9.2	Hosts and routers .....	71
6.9.3	IPv6 aspects .....	73
6.9.3.1	Improved Performance .....	73
6.9.3.2	Autoconfiguration .....	73
6.9.3.3	IPv6 to IPv4 interworking .....	73
6.9.3.3.1	Network Address/Port Translators-Protocol Translators (NAPT-PT) .....	74
6.9.3.3.2	Stateless IP/ICMP Translation Algorithm (SIIT) .....	74
6.9.3.3.3	Dual stack .....	74
6.9.3.4	Tunneling .....	76
6.9.3.5	Summary .....	76
6.10	Backward compatibility with R99-R4/Coexistence with ATM nodes .....	77
6.10.1	General .....	77
6.10.2	Interworking Options .....	78
6.10.2.1	Dual Stack operation within Rel.5 RNCs .....	78
6.10.2.1.1	Interworking with PWE3-capable ATM Switch .....	79
6.10.2.2	Transport Network Layer IWU .....	80
6.10.2.2.1	Issue on TNL IWU control protocol .....	81

6.10.3	Conclusion .....	83
6.10.4	UTRAN Architecture considerations .....	83
6.10.5	ATM/IP Interworking solution proposals .....	84
6.10.5.1	Bearer control proposal using IETF SIP/SDP .....	84
6.10.5.1.1	Description .....	85
6.10.5.1.2	Bearer control between IP and ATM nodes signalling examples .....	85
6.10.5.1.3	Use of SIP for Interworking between UTRAN ATM interfaces and UTRAN IP interfaces .....	87
6.10.5.1.3.1	Description .....	87
6.10.5.1.3.1.1	Inter Working Problem Summary .....	87
6.10.5.1.3.1.2	Approach/Aims .....	87
6.10.5.1.3.1.3	Using SIP as a Transport Bearer Signalling Protocol.....	87
6.10.5.1.3.1.4	Implementation.....	87
6.10.5.1.3.1.4.1	ACK message.....	87
6.10.5.1.3.1.4.2	Communication of endpoint information and session identification .....	89
6.10.5.1.3.1.4.2.1	SIP header fields .....	90
6.10.5.1.3.1.4.2.2	SDP parameters .....	90
6.10.5.1.3.1.4.2.3	Example message.....	91
6.10.5.2	Bearer Control proposal using a new protocol ("Q.IP-ALCAP"), optimised for concatenation with AAL Type 2 links .....	92
6.10.5.2.1	Overall Scenario for "Q.IP-ALCAP" .....	93
6.10.5.2.2	Protocol Stack for "Q.IP-ALCAP" .....	95
6.10.5.2.3	Example: Connection Establishment on Iur .....	95
6.10.5.3	IP-ALCAP based on Q.2630 .....	96
6.10.5.3.1	Benefits .....	96
6.10.5.3.2	IP-specific information in Q.2630 in Served User Transport (SUT) parameter .....	97
6.10.5.3.2.1	Served User Transport parameter in Q.2630.....	97
6.10.5.3.2.2	Structure of information .....	98
6.10.5.4	Use of IETF RSVP for ATM/IP interworking .....	100
6.10.5.4.1	Working scenarios.....	100
6.10.5.4.1.1	ATM UTRAN Node initiated RL Setup procedure .....	100
6.10.5.4.1.2	IP UTRAN Node initiated RL Setup procedure.....	102
6.10.5.4.1.3	RSVP considerations.....	103
6.10.5.5	Inter-working with a PWE3-Capable ATM Switch .....	103
Example:	Connection Establishment on Iur.....	104
6.10.6	Coexistence between Rel.5 and R99/R4 Iur Control Plane using SUA protocol.....	105
6.10.6.1	Connecting an Rel.5 RNC to a R99/R4 RNC .....	105
6.11	Synchronization .....	107
6.12	Security .....	107
6.12.1	Security Threats .....	107
6.12.2	Security Operation in IP networks.....	107
6.12.2.1	IPSec architectures .....	107
6.12.2.2	SCTP Security features .....	107
6.12.2.3	Firewalls and other systems .....	108
6.13	Iu-cs/Iu-ps harmonization .....	108
6.13.1	GTP-U for Iu user plane .....	108
6.13.1.1	Iu PS .....	108
6.13.1.2	Iu CS.....	108
6.13.1.3	GTP header for the Iu-PS user plane .....	108
6.13.1.4	User plane header simplification considerations for the Iu-PS .....	109
6.13.1.5	Proposed GTP-U-like header scenario "A" for real-time applications .....	110
6.13.1.6	GTP-U-like alternative header scenario "B" for real-time applications .....	110
6.13.1.7	Comparison of the GTP-U header and the possible new scenarios "A" and "B".....	111
6.13.1.8	Motivation for GTP-U.....	112
6.13.2	RTP for Iu-cs interface .....	112
6.13.2.1	Reasons for selecting an RTP/UDP/IP based Iu-cs User Data Transport stack.....	112
6.13.2.2	Motivation for not choosing the RTP alternative .....	113
6.13.2.2.1	General.....	113
6.13.2.2.2	Commonality with Nb interface .....	113
6.13.2.2.3	Special RTP capability .....	113
6.13.2.2.4	Bandwidth utilization .....	114
7	Agreements and associated agreed contributions .....	114

7.1	External standardization .....	114
7.2	QoS differentiation .....	114
7.3	Transport network bandwidth utilization .....	115
7.3.1	Multiple xing .....	115
7.4	User plane transport signalling .....	115
7.5	Layer 1 and layer 2 independence .....	115
7.6	Radio Network Signalling bearer .....	115
7.7	Addressing .....	116
7.8	Transport architecture and routing aspects .....	116
7.9	Backward compatibility with R99-R4/ Coexistence with ATM nodes .....	117
7.10	Synchronization .....	118
7.11	Security .....	118
7.12	Iu-cs/Iu-ps harmonization .....	118
7.13	Iur/Iub User plane protocol stacks .....	118
7.14	Iu-cs/Iu-ps user plane protocol stacks .....	118
7.14.1	Iu-cs .....	118
7.14.2	Iu-ps .....	119
7.15	IP version issues .....	119
8	Specification Impact and associated Change Requests .....	119
8.1	TS 25.401 .....	119
8.1.1	Impacts .....	119
8.1.2	List of Change Requests .....	119
8.2	TS 25.410 .....	120
8.2.1	Impacts .....	120
8.2.2	List of Change Requests .....	120
8.3	TS 25.411 .....	120
8.3.1	Impacts .....	120
8.3.2	List of Change Requests .....	120
8.4	TS 25.412 .....	120
8.4.1	Impacts .....	120
8.4.2	List of Change Requests .....	120
8.5	TS 25.413 .....	120
8.5.1	Impacts .....	120
8.5.2	List of Change Requests .....	120
8.6	TS 25.414 .....	120
8.6.1	Impacts .....	120
8.6.2	List of Change Requests .....	120
8.7	TS 25.415 .....	121
8.7.1	Impacts .....	121
8.7.2	List of Change Requests .....	121
8.8	TS 25.420 .....	121
8.8.1	Impacts .....	121
8.8.2	List of Change Requests .....	121
8.9	TS 25.422 .....	121
8.9.1	Impacts .....	121
8.9.2	List of Change Requests .....	121
8.10	TS 25.423 .....	121
8.10.1	Impacts .....	121
8.10.2	List of Change Requests .....	121
8.11	TS 25.424 .....	121
8.11.1	Impacts .....	121
8.11.2	List of Change Requests .....	121
8.12	TS 25.426 .....	122
8.12.1	Impacts .....	122
8.12.2	List of Change Requests .....	122
8.13	TS 25.430 .....	122
8.13.1	Impacts .....	122
8.13.2	List of Change Requests .....	122
8.14	TS 25.432 .....	122
8.14.1	Impacts .....	122
8.14.2	List of Change Requests .....	122

8.15	TS 25.433.....	122
8.15.1	Impacts .....	122
8.15.2	List of Change Requests.....	122
8.16	TS 25.434.....	122
8.16.1	Impacts .....	122
8.16.2	List of Change Requests.....	122
8.17	TS 25.442.....	123
8.17.1	Impacts .....	123
8.17.2	List of Change Requests.....	123
9	Project Plan .....	123
9.1	Schedule .....	123
9.2	Work Task Status.....	123
10	Open Issues .....	124
<b>Annex A: Simulation Model.....</b>		<b>126</b>
A.1	Introduction.....	126
A.2	Simulation scenarios .....	126
A.3	Simulation model framework.....	126
A.4	Source Traffic Models.....	126
A.4.1	Speech source model.....	126
A.4.2	Data source model.....	127
A.4.2.1	Data Source Model 1 .....	127
A.4.2.2	Data source model 2.....	127
A.5	RLC/FP model.....	128
A.5.1	Voice Traffic .....	128
A.5.2	Packet data Traffic.....	128
A.6	Protocol Stack Models.....	129
A.6.1	Overview.....	129
A.6.2	Module Functions.....	131
A.6.2.1	Header Compression (FFS) .....	131
A.6.2.2	Packetizer.....	131
A.6.2.3	Queues.....	131
A.6.2.4	Segment Function.....	132
A.6.2.5	Scheduler.....	132
A.6.3	Examples .....	132
A.7	Last Mile Link Models .....	132
A.8	Performance criteria .....	132
<b>Annex B: Appendix.....</b>		<b>134</b>
B.1	Additions table 7-6, clause 7.2.2 of [2]: Parameters of the AAL type 2 signalling protocol messages.....	134
B.2	Additions to table 7-7, clause 7.2.2 of [2]: Parameters of the AAL type 2 signalling protocol messages.....	135
B.3	Additions to clause 7.3 of [2]: Parameter specification of the AAL type 2 signalling protocol messages.....	135
B.4	Additions to clause 7.4 of [2]: Field specification of the AAL type 2 signalling protocol parameters.....	135
B.5	Additions to clause 8.2.2 of [2]: Nodal functions for AAL type 2 nodes without served user interaction .....	136
B.6	Additions to the annex of [2]: Nodal functions for AAL type 2 nodes without served user interaction .....	136



**Annex C: Coding of the compatibility information .....137**  
C.1 Coding of the compatibility information ..... 137  
C1.1 Parameter compatibility .....137

**Annex D: Change History ..... 138**

---

## Foreword

This Technical Report has been produced by the 3<sup>rd</sup> Generation Partnership Project (3GPP).

The contents of the present document are subject to continuing work within the TSG and may change following formal TSG approval. Should the TSG modify the contents of the present document, it will be re-released by the TSG with an identifying change of release date and an increase in version number as follows:

Version x.y.z

where:

- x the first digit:
  - 1 presented to TSG for information;
  - 2 presented to TSG for approval;
  - 3 or greater indicates TSG approved document under change control.
- y the second digit is incremented for all changes of substance, i.e. technical enhancements, corrections, updates, etc.
- z the third digit is incremented when editorial only changes have been incorporated in the document.

---

# 1 Scope

The purpose of the present document is to help the TSG RAN WG3 group to specify the changes to existing specifications, needed for the introduction of "IP Transport" option in the UTRAN for Release 5. It is intended to gather all information in order to trace the history and the status of the Work Task in RAN WG3. It is not intended to replace contributions and Change Requests, but only to list conclusions and make reference to agreed contributions and CRs. When solutions are sufficiently stable, the CRs can be issued.

It describes agreed requirements related to the Work Task, and split the Work Task into "Study Areas" in order to group contributions in a consistent way.

It identifies the affected specifications with related Change Requests.

It also describes the schedule of the Work Task.

The present document is a "living" document, i.e. it is permanently updated and presented to all TSG-RAN meetings.

---

# 2 References

The following documents contain provisions which, through reference in this text, constitute provisions of the present document.

- References are either specific (identified by date of publication, edition number, version number, etc.) or non-specific.
- For a specific reference, subsequent revisions do not apply.
- For a non-specific reference, the latest version applies. In the case of a reference to a 3GPP document (including a GSM document), a non-specific reference implicitly refers to the latest version of that document *in the same Release as the present document*.

- [1] IP-Transport in UTRAN Work Task Description, as agreed at TSG RAN#6
- [2] 3GPP TS 25.401: "UTRAN Overall Description".
- [3] 3GPP TS 25.410: "UTRAN Iu Interface: General Aspects and Principles".
- [4] 3GPP TS 25.412: "UTRAN Iu interface signalling transport".
- [5] 3GPP TS 25.420: "UTRAN Iur Interface: General Aspects and Principles".
- [6] 3GPP TS 25.422: "UTRAN Iur interface signalling transport".
- [7] 3GPP TS 25.430: "UTRAN Iub Interface: General Aspects and Principles".
- [8] 3GPP TS 25.427: "UTRAN Iur and Iub interface user plane protocols for DCH data streams".
- [9] IETF RFC 1812: "Requirements for IP Version 4 Routers", June 1995.
- [10] R. Pazhyannur, I. Ali, Craig Fox, "PPP Multiplexed Frame Option", RFC3153, August 2001..
- [11] IETF RFC 1661 (STD 51): "The Point-to-Point Protocol (PPP)", W. Simpson, Ed., July 1994.
- [12] IETF RFC 1662 (STD 51): "PPP in HDLC-like Framing", W. Simpson, Ed., July 1994.
- [13] IETF RFC 2508: "Compressing IP/UDP/RTP Headers for Low-Speed Serial Links", S. Casner, V. Jacobson, February 1999.
- [14] IETF RFC 2509: "IP Header Compression over PPP", M. Engan, S. Casner, C. Broman, February 1999.

- [15] IETF RFC 2364: "PPP Over AAL5", G. Gross, M. Kaycee, A. Lin, J. Stephens, July 1998.
- [16] IETF RFC 2661: "Layer Two Tunneling Protocol "L2TP"", W. Townsley, A. Valencia, A. Rubens, G. Pall, G. Zorn, B. Palter, August 1999.
- [17] Bruce Thompson, Tmima Koren, Dan Wing, "Tunneling multiplexed Compressed RTP (TCRTP)", <draft-ietf-avt-tcrtp.06.txt>, February 27, 2002.
- [18] Andrew J. Valencia, "L2TP Header Compression (L2TPHC)", <draft-ietf-l2tp-xt-l2tp-hc-04.txt>, October 2001.
- [19] Tmima Koren, Stephen Casner, Patrick Ruddy, Bruce Thompson, Alex Tweedly, Dan Wing, John Geevarghese, "Compressing IP/UDP/RTP headers on links with high delay, packet loss and reordering", <draft-ietf-avt-crtp-enhance-04.txt>, February 24, 2002.
- [20] IETF RFC 1990: "The PPP Multilink Protocol (MP)".
- [21] IETF RFC 2686: "The Multi-Class Extension to Multi-Link PPP".
- [22] "A Lightweight IP Encapsulation Scheme", draft-chuah-avt-lip-02.txt, M. Chuah, E. J. Hernandez-Valencia, December 2000.

NOTE 1: Expired. There is no new version.

- [23] IETF RFC 3031: "Multi-Protocol Label Switching Architecture", January 2001.
- [24] IETF RFC 2719: "Framework Architecture for Signaling Transport", October 1999.
- [25] IETF RFC 2960: "Stream Control Transmission Protocol", October 2000.
- [26] J. Loughney, G. Sidebottom, Guy Mousseau, S. Lorusso, SS7 SCCP-User Adaptation Layer (SUA), <draft-ietf-sigtran-sua-12.txt>, 11 February 2002.
- [27] IETF RFC 2460: "Internet Protocol, Version 6 (IPv6) Specification", December 1998.
- [28] IETF RFC 2462: "IPv6 Stateless Address Autoconfiguration", December 1998.
- [29] "An overview of the introduction of IPV6 in the Internet", IETF draft-ietf-ngtrans-introduction-to-ipv6-transition-08, February 2002.
- [30] IETF RFC 2893, "Transition Mechanisms for IPv6 Hosts and Routers", August 2000.
- [31] IETF RFC 3270, "MPLS Support of Differentiated Services", May 2002.
- [32] "Tunneling Multiplexed Compressed RTP in MPLS", draft-theimer-tcrtp-mpls-00.txt, IETF work in progress, June 2000.

NOTE 2: Expired. There is no new version.

- [33] "Frame Relay Fragmentation Implementation Agreement, FRF.12"  
<http://www.frforum.com/5000/Approved/FRF.12/frf12.doc>.
- [34] "Simple Header Compression", draft-swallow-mpls-simple-hdr-compress-00.txt, March 2000, work in progress

NOTE 3: Expired. There is no new version.

- [35] IETF RFC 2687: "PPP in a Real-time Oriented HDLC-like Framing".
- [36] "COPS Usage for MPLS/Traffic Engineering", draft-franr-mpls-cops-00.txt, July 2000, work in progress.

NOTE 4: Expired. There is no new version.

- [37] "Constraint-Based LSP Setup using LDP", draft-ietf-mpls-cr-ldp-05.txt, February 2001, work in progress.

NOTE 13: Expired. There is no new version.

[38] "RSVP-TE: Extensions to RSVP for LSP Tunnels", draft-ietf-mp-ls-rsvp-lsp-tunnel-08.txt, February 2001, work in progress

NOTE 5: Expired. There is no new version.

[39] "MPLS/IP Header Compression", draft-ietf-mp-ls-hdr-comp-00.txt, July 2000, work in progress.

NOTE 6: Expired. There is no new version.

[40] R3-010181: "Comparison CIP/MPLS".

[41] "MPLS/IP Header Compression over PPP", draft-ietf-mp-ls-hdr-comp-over-ppp-00.txt, July 2000, work in progress.

NOTE 7: Expired. There is no new version.

[42] IETF RFC 768: "User Datagram Protocol".

[43] 3GPP TS 21.133: "3G security; Security threats and requirements".

[44] IETF RFC 2401: "Security Architecture for the Internet Protocol", November 1998.

[45] IETF RFC 2408: "Internet Security Association and Key Management Protocol (ISAKMP)", November 1998.

[46] 3GPP TS 29.060: "General Packet Radio Service (GPRS); GPRS Tunnelling Protocol (GTP) across the Gn and Gp interface".

[47] draft-larzon-udplite-04.txt, "The UDP Lite protocol".

NOTE 8: Expired. There is no new version.

[48] 3GPP TR 23.910: "Circuit switched data bearer services".

[49] IETF RFC 791 (9/1981): "Internet Protocol".

[50] 3GPP TR 29.903: "Feasibility study on SS7 signalling transportation in the core network with SCCP-User Adaptation (SUA)".

[51] IETF RFC 2507: "IP Header Compression", M. Degermark, B. Nordgren, S. Pink, February 1999.

[52] ITU-T Recommendation Q.2630.1: "AAL Type 2 Signalling Protocol (Capability Set 1)".

[53] ITU-T Recommendation Q.2150.3: "Signalling Transport Converter on SCTP".

[54] IETF RFC 2205: "Resource ReSerVation Protocol (RSVP); Version 1 Functional Specification".

[55] IETF RFC 2210: "The use of RSVP with IETF Integrated Services".

[56] IETF RFC 2996: "Format of the RSVP DCLASS Object".

[57] IETF RFC 2543: "SIP: Session Initiation Protocol".

[58] IETF RFC 2327: "SDP: Session Description Protocol".

[59] IETF RFC 1889: "RTP: A Transport Protocol for Real-Time Applications".

[60] 3GPP TS 25.411: "UTRAN Iu interface Layer 1".

[61] ISO/IEC 8348: "Information technology – Open Systems Interconnection – Network service definition".

[62] ISO/IEC 8348/Amd.1: "Information technology – Open Systems Interconnection – Network service definition Amendment 1: Addition of the Internet protocol address format identifier",

[65] IETF RFC 2874: "DNS Extensions to Support IPv6 Address Aggregation and Renumbering", July 2000.

- [67] ITU-T SG11: TD GEN/11-49r1 "Draft Signalling Requirements for AAL Type 2 to IP Interworking (TRQ.AAL2IP.iw)" February 2002
- [68] ITU-T SG11: TD GEN/11-54r3 "Report of Q.6/11, Joint Qs.6 & 9/11 and Q.9/11 discussions" March 2002
- [69] 3GPP TSG RAN WG3: R3-021366 "A2IP Signalling Protocol (Q.IPALCAP Spec draft)" May 2002
- [70] draft-ietf-pwe3-frame-work-01.txt: "Framework for Pseudo Wire Emulation Edge-to-Edge (PWE3)"
- [71] draft-ietf-pwe3-atm-encap-01.txt: "Encapsulation Methods for Transport of ATM Cells/Frame Over IP and MPLS Networks"

## 3 Definitions, symbols and abbreviations

### 3.1 Definitions

For the purposes of the present document, the following terms and definitions apply.

### 3.2 Symbols

For the purposes of the present document, the following symbols apply:

### 3.3 Abbreviations

For the purposes of the present document, the following abbreviations apply:

AAAL2	ATM Adaptation Layer type 2
ACK	Acknowledgement
ALCAP	Access Link Control Application Protocol
ATM	Asynchronous Transfer Mode
CDN	Compressing/Decompressing Node
CRC	Cyclic Redundancy Check
CRNC	Controlling Radio Network Controller
DRNC	Drift Radio Network Controller
FEC	Forwarding Equivalence Class
FP	Frame Protocol
FR	Full Rate
GPRS	General Packet Radio Service
GSM	Global System for Mobile communications
GTP	GPRS Tunneling Protocol
HDLC	High Level Data Link Control
ICMP	Internet Control Message Protocol
IP	Internet Protocol
Ipv4	Internet Protocol Version 4
Ipv6	Internet Protocol Version 6
L2TP	Layer Two Tunneling Protocol
LAN	Local Area Network
LCP	Link Control Protocol
LDP	Label Distribution Protocol
LEN	LENgth
LSB	Least Significant Bit
LSP	Label-Switched Path
LSRs	Label Switched Routers
LXT	Length ExTension
MPLS	Multi-Protocol Label Switching

MSB	Most Significant Bit
MTU	Maximum Transmission Unit
NAPT-PT	Network Address/Port Translators-Protocol Translators
NBAP	Node B Application Part
NCP	Network Control Protocol
NSP	Network Service Part
O&M	Operations & Maintenance
PDCP	Packet Data Convergence Protocol
PDU	Protocol Data Unit
PPF	Protocol Field Flag
PPP	Point-to-Point Protocol
PPPMux	PPP Multiplexing
PVC	Permanent Virtual Circuit
PWE3	Pseudo Wire Emulation Edge to Edge
QoS	Quality of Service
RAB	Radio Access Bearer
RANAP	Radio Access Network Application Part
RFC	Request For Comments
RNL	Radio Network Layer
RNSAP	Radio Network Subsystem Application Part
RSVP	Resource Reservation Protocol
SAPC	Service Application PLMN Code
SCCP	Signalling Connection Control Part
SEP	Signalling End Point
SIIT	Stateless IP/ICMP Translation algorithm
SP	Signalling Points
SRNC	Serving Radio Network Controller
SS7	Signalling System No. 7
SSSAR	Service Specific Segmentation and Re-assembly sublayer
STP	Signalling Transfer Point
SUGR	Served User Generated Reference parameter
TLV	Type-Length-Value
TNL	Transport Network Layer
ToS	Type of Service
TTI	Transmission Timing Interval
UDP	User Datagram Protocol
UMTS	Universal Mobile Telecommunications System
UTRAN	Universal Terrestrial Radio Access Network
VPN	Virtual Private Network

---

## 4 Introduction

### 4.1 Task Description

The work task is described in the contribution [1], which has been agreed at TSG-RAN#6. The purpose of this new work task is to enable the usage of IP technology for the transport of signalling and user data over Iu, Iur and Iub in the UTRAN.

### 4.2 Rationale for IP Transport

This clause will describe some rationale for IP Transport option in the UTRAN.

Some mobile operators require a UTRAN transport solution for IP as an alternative to ATM.

This is partly due to the following reasons:

- 1) IP is developing to allow the support of a mix of traffic types and to support low speed links.

- 2) The popularity of the Internet/World Wide Web and corporate LANs puts price pressure on IP networking equipment.
- 3) IP is the technology to the "desktop" (terminals) so most applications will be based on IP.
- 4) Operation and maintenance networks will be based on IP. To have networks with homogeneous technology can save management and operations costs.
- 5) IP, like ATM, is a packet-switched technology and provides the opportunity to use transport resources in an efficient manner.
- 6) IP is Layer 2 independent.
- 7) Autoconfiguration capabilities.
- 8) Dynamic update of routing tables.

It is clear that there will be IP data traffic in the mobile networks. It should be a matter of an operator's choice whether IP or ATM is used in the transport network to carry the various types of traffic from the circuit and packet domains.

---

## 5 Requirements

This clause details high level requirements for the IP UTRAN option.

### 5.1 General requirements

Whenever possible, preference for already standardized protocols should be used, e.g. IETF protocols for the IP related parts, in order to have wide spread acceptance and avoid double work. Relevant UTRAN recommendations may also be standardized in the IETF.

By "IETF protocols", it is meant standards RFCs and working group internet drafts.

The use of Ipv6 shall not be precluded.

### 5.2 Independence to Radio Network Layer

The changes should only be made to the Transport Network Layer (TNL) since the Radio Network Layer should be independent of the TNL. The impact on the RNL shall be minimized but there could be some minor changes to the Radio Network Layer, e.g. addressing.

Not requiring the end point RNL user plane frame protocols to be aware of the underlying multiplexing, i.e., transparency.

### 5.3 Services required by the upper layers of user planes of Iu

For the Iu\_CS the requirement is transfer of user data (TS 25.415) and in-sequence delivery is not required.

It is a requirement that the Radio Network Layer (RNL) functional split shall not be changed depending on the TNL technology. This is in line with the architectural principle of separation of the RNL and TNL stated in [2]. If the RNL is different for different transport technologies, backward compatibility is lost or complicated and an implementation is potentially complicated when changing transport. The RNL shall be independent from the transport type.

In order to be compatible with the Release 99 / Release 4 IuCS, Iur, and Iub, the following requirements for setting up transport bearers shall apply for IP transport:

The SRNC (Iu/Iur)/CRNC (Iub) TNL receives a request from the RNL to establish a bidirectional transport bearer. The request includes the end system address and transport bearer association received from the peer. It also includes the quality of service and resources required from the transport network.



## 5.4 Services required by the upper layers of user planes of Iur and Iub

In the current specifications the AAL2/ATM provides the services to radio network layer. The services required by the radio network layer are:

- connection identification;
- in-sequence delivery of PDUs to upper layers (TS 25.425, TS 25.427). If this means re-ordering of PDUs or simply not sending data that have been received out-of-sequence is not clearly stated.

It is a requirement that the Radio Network Layer (RNL) functional split shall not be changed depending on the TNL technology. This is in line with the architectural principle of separation of the RNL and TNL stated in [2]. If the RNL is different for different transport technologies, backward compatibility is lost or complicated and an implementation is potentially complicated when changing transport.

In order to be compatible with the Release 99 / Release 4 IuCS, Iur, and Iub, the following requirements for setting up transport bearers shall apply for IP transport.

The SRNC (Iu/Iur)/CRNC (Iub) TNL receives a request from the RNL to establish a bidirectional transport bearer. The request includes the end system address and transport bearer association received from the peer. It also includes the quality of service and resources required from the transport network.

## 5.5 Coexistence of the two transport options

In Release 5, UTRAN(s) may have both ATM and IP transport networks. Following requirements with regards to ATM and IP transport network coexistence shall be met:

- The specifications shall ensure the co-existence of ATM and IP Transport options within UTRAN, i.e. parts of UTRAN using ATM and parts of UTRAN using IP transport.
- In Release 5, ATM and IP Transport Options shall rely on the same functional split between Network Elements.

The transport technology choices of an UMTS operator will vary. Some will use AAL2/ATM. Others will use IP and others will use both AAL2/ATM and IP. Interoperability between Release 99 / Release 4 and later UTRAN ATM interfaces and UTRAN IP interfaces (for example, IP Iur to ATM Iur) is an important function for operators deploying both types of transport networks. An interworking solution shall be included in the specification.

The following are requirements for the interworking solution:

- 1) It shall be possible for a UTRAN to support Release 99 / Release 4 and later ATM interfaces and UTRAN IP interfaces. One means of assuring that UTRAN nodes can communicate with each other is for nodes to have both ATM and IP interfaces.
- 2) Where Node terminating Iu, Iur or Iub does not support ATM interfaces (Release 99 / Release 4 and later releases) and UTRAN IP interfaces, an TNL interworking function shall be required to enable the nodes to inter-operate between ATM and IP technologies.

## 5.6 Quality of Service

The mechanisms to secure the quality of service parameters, timing aspects, and packet loss have to be considered.

Quality of service parameters include service class definition and congestion control requirements. Timing aspects include delay and delay-variation requirements.

TNL shall provide the appropriate QoS requested by the RNL. However, the way the end-to-end transport network actually implements the QoS shall not be specified below IP.

Mechanisms that provide QoS or efficient bandwidth utilization must take into account UTRAN traffic (Control plane, user plane, O&M) and non-UTRAN traffic.

## 5.7 Efficient utilization of transport resources

Efficient use of the bandwidth of the transport network shall be considered, e.g. by reducing the protocol overhead (via Header compression, multiplexing, ...).

Iub/Iur protocols shall operate efficiently on low speed point to point links which may be shared with other traffic (e.g. GSM/GPRS Abis, UMTS Release 99 / Release 4 compliant interfaces).

The TNL shall provide the functionality of sufficiently de-coupling the bandwidth optimization techniques such that they can be used independently of each other.

The TNL shall provide the means to enable or disable the schemes for efficient bandwidth usage (e.g. header compression, multiplexing, etc ...).

In addition, for high-speed routed segments, it is important that specific bandwidth optimization is not required at every hop.

Mechanisms that provide efficient bandwidth utilization must take into account the QoS requirements of all UTRAN traffic (Control plane, user plane, O&M) also in case of non UTRAN traffic.

## 5.8 Layer 2/Layer 1 independence

The functionality of the higher layers shall be independent from the Layer 2 and Layer 1 technologies. The higher layers refer both to the higher protocol layers of the Transport Network Layer and to all Radio Network Layer.

The Layer 2 and Layer 1 shall be capable to fulfill the QoS requirements set by the higher layers. IP Transport Flexibility.

By defining protocol stacks on Iur, Iub and Iu, one may not make any restrictive assumption on IP transport network topology. They shall adapt to a wide range of networks (LAN to WAN) and no preference shall be expressed on routed vs. point to point networks.

## 5.9 Transport Bearer Identification

In Release 99 / Release 4 UTRAN, ATM transport provides the ability to uniquely address individual flows. In an IP based UTRAN, the transport network has to provide the means to uniquely address individual flows - both in the user as well as signalling planes.

## 5.10 Transport Network Architecture and Routing

### 5.10.1 Network elements

Network elements e.g. RNC, Node B need to be identified by one or more IP addresses.

## 5.11 Radio Network Signalling Bearer

The following are requirements on the signalling transport protocol:

- 1) It shall be possible for a UTRAN node to support multiple signalling bearers of different transport technologies at the same time.
- 2) A signalling transport shall allow multiple RNL signalling protocol entities terminating on a node to use a common physical interface.
- 3) A signalling transport shall provide a means of uniquely identifying the originating and terminating signalling entities.

## 6 Study Areas

This clause gives a summary of areas that have been identified where work needs to be performed to complete the work item.

As work proceeds in Release 5 with regard to IP in the UTRAN, the Work Task is divided in the following Study Areas.

### 6.1 External standardization

There is a need for identifying supporting work required by other Standards Bodies. Certain protocols and/or QoS mechanisms may be indicated which are not currently supported in the industry. Appropriate liaisons should be identified. Procedure for LSs with IETF should be defined. RAN3 needs to start the IETF official communication channels.

### 6.2 User plane proposed solutions

This study area is intended to describe the various proposed solutions for Iur and Iub, Iu-cs and Iu-ps.

#### 6.2.1 CIP solution

##### 6.2.1.1 CIP Container

The aggregation functionality allows to multiplex CIP packets of variable size in one CIP container, also of variable size. This is necessary for an efficient use of the bandwidth of the links. It is achieved by amortizing the IP/UDP overhead over several CIP packets. The resulting packet structure is depicted below:

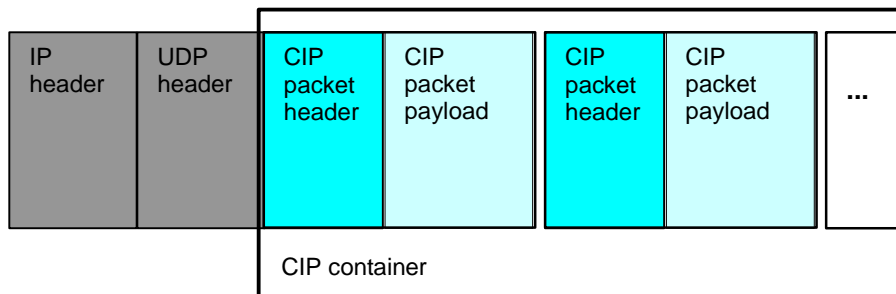

**Figure 6-1: Generic CIP Container format**

##### 6.2.1.2 CIP Packets

###### 6.2.1.2.1 Segmentation and Re-assembly

A segmentation/re-assembly mechanism allows to split large FP PDUs in smaller segments. There has to be a trade-off between efficiency (IP header/payload ratio) and transmission delay. Large data packets have to be segmented in order to avoid IP fragmentation and to keep transmission delays low.

The following figure shows the segmentation process from a FP PDU to several CIP packet payloads.

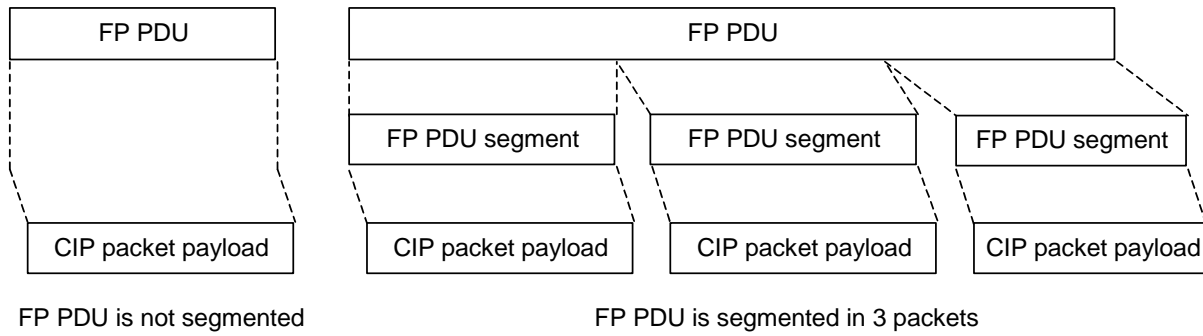

**Figure 6-2: CIP segmentation**

6.2.1.2.2 CIP Packet Header Format

The proposed CIP packet header format is shown in the following figure.

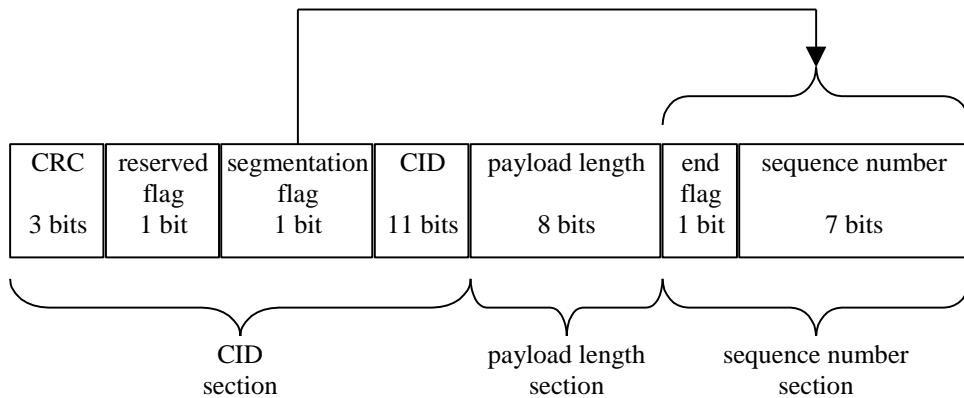

**Figure 6-3: CIP packet header format**

6.2.1.2.3 The CIP Packet Header Fields in Detail.

The CIP packet header is composed of three clauses:

- 1) The **CID clause**, also containing CRC and flags is used for multiplexing. This clause is mandatory.
  - The **CRC** protects the reserved flag, the segmentation flag and the CID.
  - The **reserved flag** is for further extensions.
  - The **segmentation flag** indicates that the sequence number field and the end flag are present. These fields are only needed for segmented packets. Because also the aggregation of non-segmented PDUs is a frequent case, e.g. voice, these fields can be suppressed by means of the segmentation flag to save bandwidth.
  - The **CID** is the Context ID. This is the identifier of the multiplex functionality, e.g. to distinguish the flows of different calls or users by the higher layers.
- 2) The **payload length clause** is used for aggregation. This clause is mandatory.
  - The **payload length** is the length of the CIP packet payload. So, CIP packets, containing e.g. FP-PDUs with voice or FP-PDU segments with data, can be between 1 and 256 octets in size.

- 3) The **sequence number clause**, also containing the end-flag is used for segmentation. This clause is optional. It exists if the segmentation flag is set.
- The **end-flag** marks the last segment of a packet in a sequence of segments. This field is only present if the segmentation flag is set.
  - The **sequence number** is to reassemble segmented packets. This field is only present if the segmentation flag is set. It is incremented for each segment (modulo) and is not reset if the segments of a new packet start. The sequence numbers are maintained for each CID individually.

#### 6.2.1.2.4 Discussion of the CIP Packet Header Field Sizes

One aim is to have byte aligned boundaries where possible. So, adding a few bits to some fields would increase the header size by at least 1 byte. The proposed CIP packet header has a length of 3 bytes for non-segmented packets and 4 bytes for segmented packets.

- The **CID field** size determines how many flows between a pair of network elements can be supported at the same time. The proposed size of 11 bits allows 2 048 CIDs. This is more than 8 times the amount that AAL2 offers. It can be extended by additional UDP ports, each having its own CID address space.
- The size of the **Payload Length** field. This choice determines the maximum size of a CIP packet payload, containing either a whole FP-PDU or a segment of a FP-PDU. Typically, these packets are either small by nature or they are made small intentionally. So, to stay on byte boundaries, the length field for the CIP packet payload size is proposed to be 1 byte.
- The size of the **Sequence Number** field determines in how many segments a FP PDU can be split before this modulo-incremented field wraps around and becomes ambiguous. The proposed size is 7 bits i.e. 128 segments. One bit has to be reserved for the end-flag. These two fields are combined together because they are both optional and are needed only in case of segmentation. The segment numbers also protect segments that arrive late, from being injected in the next packet with the same CID during the reassembly process. This is the reason why the segment numbers are counted modulo over the full range and do not start with 0 at every new FP PDU. A very worst case scenario with a 2 Mbit/s source would deliver 20 480 bytes within 80 ms. If this PDU is cut to pieces of 256 bytes, 80 segments would result.
- The size of the **CRC** depends on how many bits need protection. A bit error in the length field would interpret the wrong bytes as the next header. But this can be detected, because the next header is again protected by its own CRC. So, the payload length needs no protection. An error in the sequence number would be detected by either placing a segment in a position where another segment with the same number already is, or would be regarded as 'too late' because it belongs to the segment number range of a PDU already processed. Even if the segment is injected in the wrong place, it would be detected by a checksum error of the higher layer. So, the only fields that need protection are the flags and the CID. An error in the CID is critical, because it would inject a formally correct (non-segmented) PDU in the flow to another CID, i.e. to the wrong destination. This might be difficult to detect by the higher layer, because the CID is not a part of the PDU of the higher layer. And so, the CRC of the higher layer alone is not a sufficient protection mechanism against the erroneous injections of formally correct PDUs. For the 13 bits to be protected, a 3 bit CRC seems to be sufficient.

#### 6.2.2 LIPE solution

[Editor's note: This clause refers to deleted or expired ietf-drafts]

The LIPE scheme uses either UDP/IP or IP as the transport layer. Each LIPE encapsulated payload consists of a variable number of multimedia data packet (MDP). For each MDP, there is a multiplexing header (MH) that conveys protocol and media specific information.

The format of an IP packet conveying multiple MDPs over UDP using a minimum size MH is below:

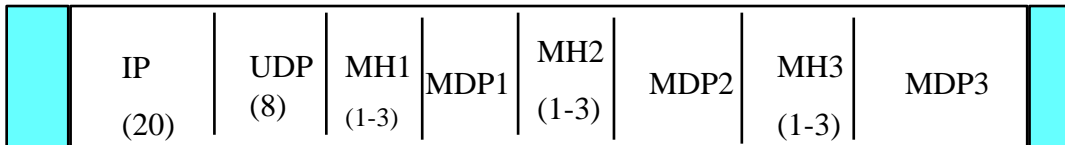

MH: Multiplexed Header MDP: Multiplexed Data payload

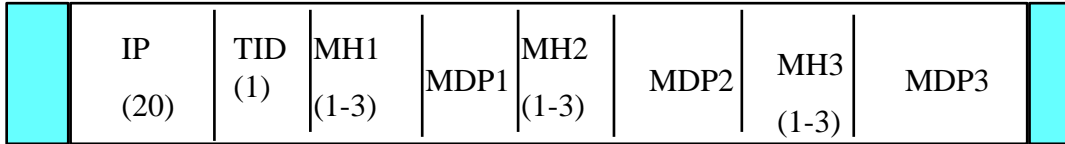

TID: Tunnel Identifier



PPP/HDLC Framing

**Figure 6-4: LIPE UDP/IP or IP Encapsulation Format**

Figure 6-4 shows the encapsulation format of a LIPE packet. Details of the multiplexed header is described in the next clause.

**6.2.2.1 Details of Multiplexed Header**

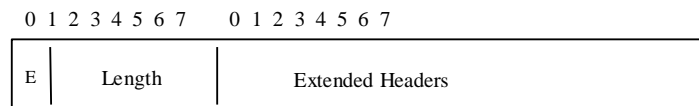

**(a) Basic Multiplexed Header**

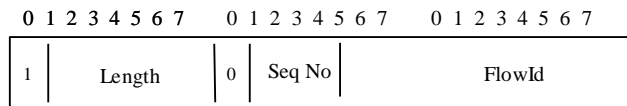

**(b) Extended Multiplexed Header with Seq No & Flow ID**

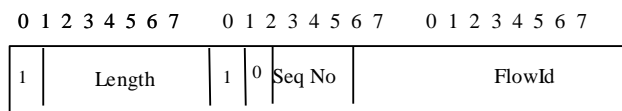

**(c) Extended Multiplexed Header with Seq No & Flow ID**

**Figure 6-5: Formats of Multiplexed Header**

**6.2.2.2 Basic Header**

The Multiplexing Header (MH) comprises of two components: The extension bit (the E bit) and the MDP length field. Optional Extension Headers can be supported via the E bit. The MH format is shown in figure 6-5 (a). The E bit is the least significant bit of the first byte of the MH header. It is set to one/zero to indicate the presence/absence of an extension header. If the E-bit is set to one, the first header extension MUST be a Extended Header Identifier field. The Length field is 7 bit. This field indicates the size of the entire MDP packet in bytes, including the E bit, the length field and optional extension headers (if they exist).

**6.2.2.3 Extensions**

Extension headers are used to convey userspecific information. It also facilitates the customization of LIPE to provide additional control information e.g. sequence number, voice/video quality estimator.

The 16-bit EHI is the first field in any Extension Header. It is used to identify MDPs belonging to specific user flows. The format of a LIPE encapsulated payload with a FlowID extension header is shown in Figure 6-5 (b). The least significant bit of the 1<sup>st</sup> byte of EHI is the X-bit. When the X-bit is clear, it means there is a 3 bit header SEQUENCE NO. and a 12 bit FlowId. When the X bit is set to one, it indicates that the EOF bit and the 3 bit Seq Number fields exist and that the FlowID field is 11 bit. The second least significant bit is the End Of Fragment (EOF) indicator. When EOF is set to 0, it means this is the last fragment (for packets that are not fragmented, this bit is always 0). When EOF is set to 1, it means there are more fragments coming.

### 6.2.3 PPP-MUX based solution

[Editor's note: This clause refers to deleted or expired ietf-drafts]

#### 6.2.3.1 PPP Multiplexed Frame Option Over HDLC

PPP Multiplexing (PPPMux) [10], figure 6-6, provides a method to reduce the PPP framing [11] [12] overhead used to transport small packets, e.g. voice frames, over slow links. PPPmux sends multiple PPP encapsulated packets in a single PPP frame. As a result, the PPP overhead per packet is reduced. When combined with a link layer protocol, such as HDLC, this offers an efficient transport for point-to-point links.

At a minimum, PPP encapsulating a packet adds several bytes of overhead, including an HDLC flag character (at least one to separate adjacent packets), the Address (0xFF) and Control (0x03) field bytes, a two byte PPP Protocol ID, and the two byte CRC field. Even if the Address and Control Fields are negotiated off and the PPP Protocol ID is compressed, each PPP encapsulated frame will include four bytes of overhead. This overhead can be reduced to one or two bytes.

The key idea is to concatenate multiple PPP encapsulated frames into a single PPP multiplexed frame by inserting a delimiter before the beginning of each frame. Each PPP encapsulated frame is called a PPP subframe. Removing the PPP framing characters can save several bytes per packet, reducing overhead.

During the NCP negotiation phase of PPP, a receiver can offer to receive multiplexed frames using a PPP Mux Control Protocol (PPPMuxCP). Once PPPMuxCP has been negotiated, the transmitter may choose which PPP frames to multiplex. Frames should not be re-ordered by either the transmitter or receiver regardless of whether they arrive as part of the PPP multiplexed frame or by themselves.

The PPP Protocol ID field of a subframe can be removed if the PPP Protocol ID of that subframe is the same as that for the preceding subframe. A Protocol Field Flag (PFF) bit and a Length Extension (LXT) field is defined as part of the length field (thus reducing the length field from an 8-bit to a 6-bit field). The PFF bit is set if the PPP Protocol ID is included in the subframe. The PFF bit is cleared if the PPP Protocol ID has been removed from the subframe. The PFF bit may be set to zero for the first subframe in a PPP multiplexed Frame if the Protocol ID is the same as the default PID, as specified by the PPPMuxCP option. The transmitter is not obligated to remove the PPP Protocol ID for any subframe.

The format of the complete PPP frame along with multiple subframes is shown in figure 6-6. Note that regardless of the order in which individual bits are transmitted, i.e. LSB first or MSB first, the PFF bit will be seen to be the MSB of a byte that contains both the PFF and the subframe length field.

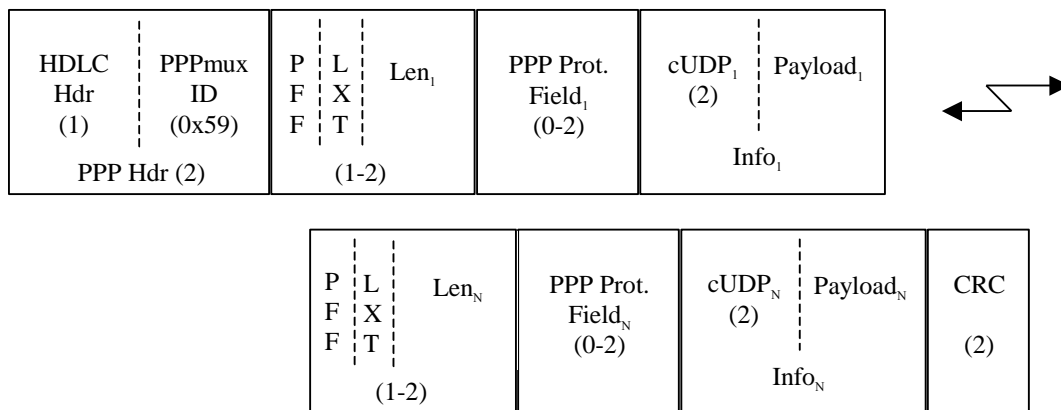

Figure 6-6: PPPMux frame with multiple subframes

**PPP Header:** The PPP header contains the HDLC header and the PPP Protocol Field for a PPP Multiplexed Frame (0x59). The PPP header compression options (ACFC and PFC) may be negotiated during LCP and could thus affect the format of this header.

**Protocol Field Flag (PFF):** This one bit field indicates whether the PPP Protocol ID of the subframe follows the subframe length field. PFF = 1 indicates that the protocol field is present for this subframe. PFF = 0 indicates that the protocol field is absent for this subframe. If PFF = 0 then the PPP Protocol ID is the same as that of the preceding subframe with PFF = 1, or it is equal to the default PID value of the PPPMuxCP Option for the first subframe.

**Length Field:** The length field consists of three subfields:

1) Protocol Field Flag (PFF):

The PFF refers to the most significant bit of the first byte of each subframe. This one bit field indicates whether the PPP Protocol ID of the subframe follows the subframe length field. For the first subframe, the PFF bit could be set to zero if the PPP protocol ID of the first subframe is equal to the default PID value negotiated in PPPMuxCP. PFF = 1 indicates that the protocol field is present (and follows the length field) for this subframe. PFF = 0 indicates that the protocol field is absent for this subframe. If PFF = 0 then the PPP Protocol ID is the same as that of the preceding subframe with PFF = 1, or it is equal to default PID value of the PPPMuxCP Option for the first subframe. The transmitter is not obligated to remove the PPP Protocol ID for any subframe.

2) Length Extension (LXT):

This one bit field indicates whether the length field is one byte or two bytes long. If the LXT bit is set, then the length field is two bytes long (a PFF bit, a length extension bit, and 14 bits of sub-frame length). If the LXT bit is cleared, then the length field is one byte long (a PFF bit, a length extension bit, and 6 bits of sub-frame length).

3) Sub-frame Length (LEN):

This is the length of the subframe in bytes not including the length field. However, it does include the PPP Protocol ID if present (i.e. if PFF = 1). If the length of the subframe is less than 64 bytes (less than or equal to 63 bytes), LXT is set to zero and the last six bits of the length field is the subframe length. If the length of the subframe is greater than 63 bytes, LXT is set to one and the last 14 bits of the length field is the length of the subframe. The maximum length of a subframe is 16,383 bytes. PPP packets larger than 16,383 bytes will need to be sent in their own PPP frame. A transmitter is not required to multiplex all frames smaller than 16,383 bytes. It may chose to only multiplex frames smaller than a configurable size into a PPP multiplexed frame.

**Protocol Field:** This field contains the Protocol Field value for the subframe. This field is optional. If PFF = 1 for a subframe, the protocol field is present in the subframe, otherwise it is inferred at the receiver.

The receiver MUST support Protocol-Field-Compression (PFC) for PPP Protocol Ids in this field. Thus the field may be one or two bytes long. The transmitter SHOULD compress PPP Protocol Ids in this field that have an upper byte of zero (i.e. Protocol Ids from 0x21 thru 0xFD). This Protocol Field Compression is not related to the negotiation of PFC during LCP negotiation, which affects the length of the PPP Multiplexed Frame Protocol ID.

**Information Field:** This field contains the actual packet being encapsulated. Any frame may be included here with the exception of LCP Configure Request, ACK, NAK and Reject frames and PPP multiplexed frames. If LCP is renegotiated, then PPP Multiplexing MUST be disabled until PPP Mux Control Protocol is negotiated.

In the proposed protocol stack the Information Field is comprised of a compressed IP/UDP (cUDP) [12] [13] header (with a minimum length of 2 bytes and maximum of 5 bytes) and the payload of the packet. The PPPMuxCP default PID is 0x67, corresponding to cUDP. (A 2-byte cUDP header assumes an 8-bit CID and no UDP checksum.)

### 6.2.3.2 PPP Multiplexed Frame Option Over ATM/AAL5

This protocol stack uses the same PPPmux option as described above, but carries PPP over an ATM/AAL5 link layer [14] [15], figure 6-7. Here the HDLC header and CRC trailer is replaced with an ATM header and AAL5 trailer.



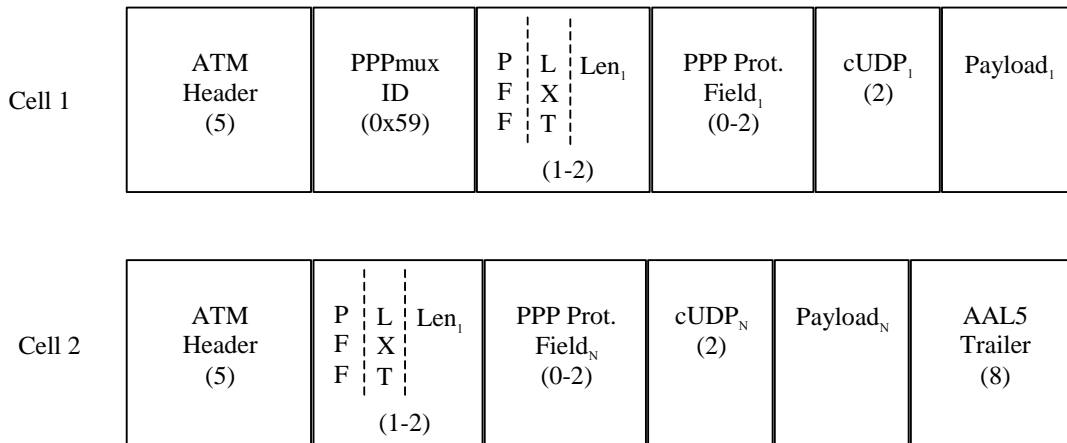

[Editor's note: Payload position needs to be fixed]

Figure 6-7: PPPmux over an ATM/AAL5

6.2.3.3 PPP Multiplexed Frame Option Over L2TP Tunnel (TCRTP)

[Editor's note: This clause refers to deleted or expired ietf-drafts]

In cases where a routed WAN interface is required, one may still use PPPmux, but tunnel it via L2TP [16]. This protocol is called Tunnelled Compressed RTP (TCRTP) -[17], figure 6-8.

L2TP tunnels should be used to tunnel the cUDP payloads end to end. This is a natural choice since cUDP payloads are PPP payloads, and L2TP allows tunnelled transport of PPP payloads. L2TP includes methods for tunnelling messages used in PPP session establishment such as NCP. This allows the procedures of RFC2509 to be used for negotiating the use of cUDP within a tunnel and to negotiate compression/decompression parameters to be used for the cUDP flow.

A companion draft [18] describes a method of compressing L2TP tunnel headers from 36 bytes (including the IP/UDP/L2TP headers) to 21 bytes. L2TPHC packets include an IP header, using the L2TPHC IP protocol id. The UDP header is omitted, and the L2TPHC header is reduced to 1 byte. The added overhead is now 21 bytes of the IP header.

Enhancements to CRTP [19] are not needed for cUDP header compression.

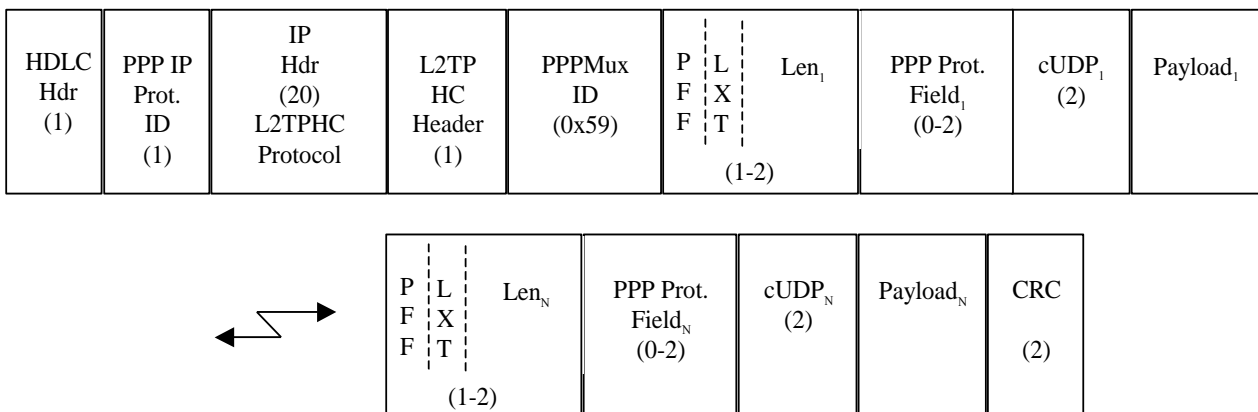

Figure 6-8: PPPmux tunnelled over Routed Network using L2TPHC (with PPP as Layer 2)

A more bandwidth efficient way to send TCRTP over a PPP link is to compress the L2TP IP header with cUDP (this is referred to as cTCRTP).

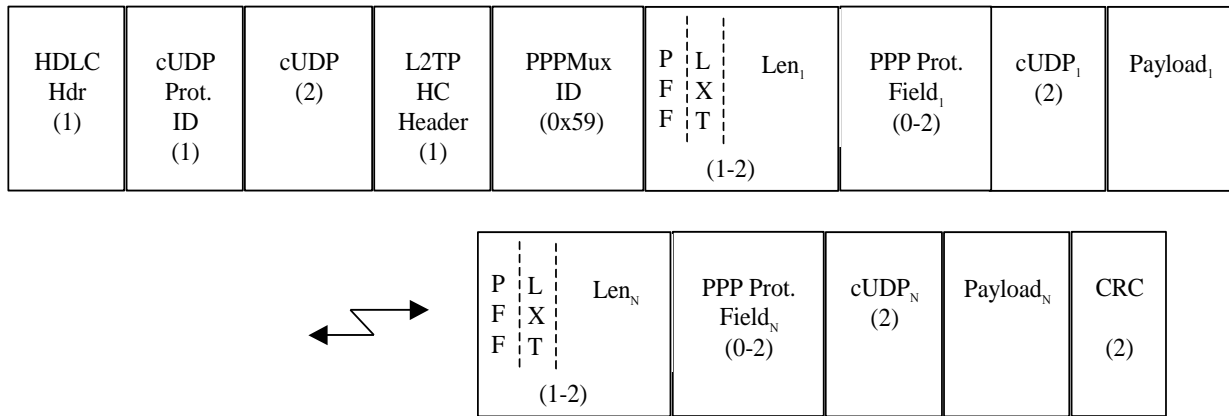

Figure 6-9: cTCRTP PPPMux packet tunnelled in L2TPHC over a PPP link

## 6.2.4 MPLS solution

[Editor's note: This clause refers to deleted or expired ietf-drafts]

[Editor's note: Detailed reference to RFCs and other standards need to be provided, and overheads need to be calculated again according to the detailed references.]

### 6.2.4.1 MPLS General Description

The Multi-Protocol Label Switching (MPLS) protocol is an interstitial, layer 2.5 protocol which complements and enhances the IP protocol, in that it offers an alternative method of forwarding IP packets, while reusing the existing IP routing protocols (e.g., OSPF, BGP).

MPLS can run on top of numerous L2 technologies (PPP/Sonet, Ethernet, ATM, FR, WDM Lambdas, etc.).

MPLS forwards IP packets based on a 20-bit label. An ingress router at the edge of an MPLS domain, called a Label Edge Router, decides which subset of incoming packets is to be mapped to which Label-Switched Path (LSP), and then adds the corresponding label to each packet as it arrives. This subset of packets that is forwarded in the same manner over the same LSP is called a Forwarding Equivalence Class (FEC). Packets are then forwarded through the MPLS domain by the Label Switched Routers (LSRs) based on the label. At the egress edge of the MPLS domain, the egress LSR removes the MPLS label from each IP packet, and subsequently the IP packets are forwarded by conventional IP forwarding.

Each pair of LSRs on the Label-Switched Path (LSP) must agree on which label to use on that segment of the LSP. This agreement is achieved by using a set of procedures, called a label distribution protocol. The label distribution protocol associates a Forwarding Equivalence Class (FEC) with each LSP it creates. The FEC associated with an LSP specifies which packets are "mapped" to that LSP.

### 6.2.4.2 Routing with MPLS

MPLS, as a complementary forwarding technique to IP forwarding, offers the following advantages:

- **coexistence with IP Hop-By-Hop Routing:** an LSR is capable of forwarding both IP packets and MPLS frames;
- **traffic engineering capabilities:** MPLS uses the label prefixed to an IP packet to determine the path that the packet will take through the network, regardless of the IP addresses contained in the packet. Routes through the network can be engineered to meet various network or operator requirements (such as QoS or traffic load). For example, the traffic at the edge of the MPLS domain can be segregated according to QoS class and the packets can be directed along the MPLS paths defined over the route that meets their QoS requirements (see QoS clause hereafter);
- **flexibility due to label semantics:** the meaning of the labels can be tailored to what needs to be achieved in the network. For example, labels can be used to specify treatment for QoS, multiplexing, multicasting, header compression, etc;

- **flexibility due to label stacking:** MPLS supports the ability to stack more than one label in front of an IP packet. LSRs are capable of pushing, popping and swapping labels. This allows for:
  - different addressing in different subnets;
  - efficient inherent support for tunnels-in-tunnels. This can be used, for example, for IP VPN and mobility support;
- **transparent routing:** the compressed packet passes transparently through the intermediate LSRs. This is in contrast to schemes based, for example, on PPP where either header (de-)compression must occur on a hop-by-hop basis or the compressed packets must be carried inside a second, uncompressed IP tunnel packet. MPLS thereby makes network nodes much simpler;
- **fast rerouting:** MPLS protection switching mechanisms can be applied to achieve fast restoration from a node failure. Both local and end-end protection could be used to achieve fast tunnel restoration which is an essential requirement for a carrier grade network. Backup tunnels may also be combined with load sharing to allow a more even traffic distribution;
- **match any layer 2:** MPLS can run on top of numerous L2 technologies. When MPLS is used over ATM or Frame Relay, the LSP can be mapped onto layer 2 connections such as VCCs or PVCs.

### 6.2.4.3 Support for QoS requirements

Finally, the MPLS supports a number of QoS differentiation mechanisms for IP flows:

- **QoS engineered paths:** the flows with different QoS characteristics can be separated on different LSPs. LSPs can be engineered to meet the QoS requirements for each class of traffic supported by the network. The traffic at the edge of the MPLS domain can be segregated according to QoS class and the packets can be directed along the MPLS paths defined over the route that meets their QoS requirements.

Taking again our example over narrow-band links, QoS efficient LSPs could pave the way for real-time flows whereas user data with long payloads could be routed over separate LSP(s). By so doing, there is no risk to have big packets blocking the way of delay-sensitive small packets. Best efficiency can be achieved by combining the use of MPLS with the appropriate layer 2 mechanisms depending the technology used at layer 2. Taking again our example with ATM over such narrow-band links, the different LSPs (i.e. VCCs) are multiplexed onto the same physical link by the ATM VCC multiplexing function respecting the VCC QoS, thus the LSP QoS. Then QoS characteristics of real-time flows (such as IP DiffServ marking) can be used to select the LSP (i.e. the ATM VCC) the packet should be sent over. This is fairly easy to achieve through the VPI/VCI – label mapping defined above;

- **integration with Differentiated Services (DiffServ):** DiffServ provides a mechanism for defining the treatment that a packet will receive as it is forwarded through an IP network. Although there are no performance guarantees with DiffServ, it can be used to improve end-to-end performance over large scale, wide area networks. MPLS can support DiffServ by using the DiffServ marking in each packet to determine:
  - which path the packet should be sent over. Paths can then be engineered, as mentioned above, to provide more deterministic performance guarantees than are available with pure DiffServ in a routed network;
  - the treatment that packets will receive over a specific path. In this model, closely resembling the basic DiffServ model, packets with different QoS requirements can be carried over the same MPLS path. Within that path, the DiffServ marking is used to prioritize and schedule packets to provide "better" treatment for some packets with respect to other packets carried over that same path.
- **In-Sequence Packet Delivery:** because the route that a packet will travel through the network is precisely defined by the Label Switched Path, packets are guaranteed to be received in the same order that they were transmitted.

### 6.2.4.4 Efficient, QoS-enabled transmission over routed domains with MPLS

Let us consider a general network configuration, which includes a broadband routed cloud as well as a narrowband link, typically on the last-mile link to the Node B. This configuration is shown in figure 6-10.

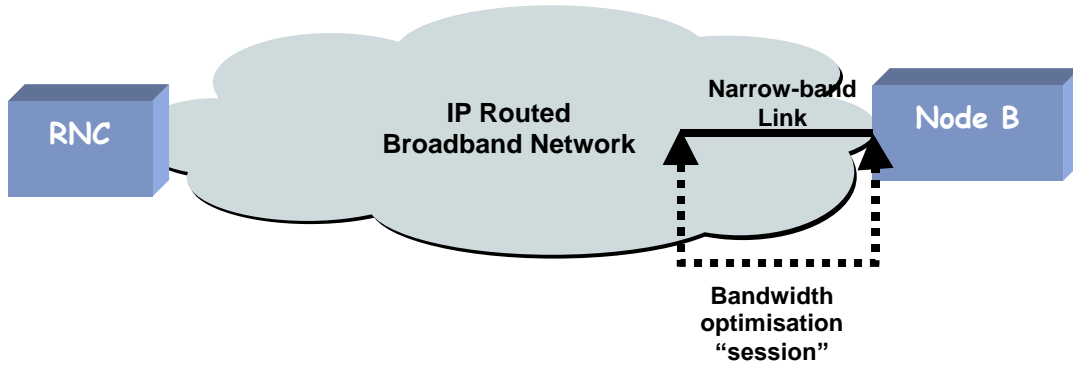

Figure 6-10: General UTRAN network configuration

Figure 6-10 also shows the most likely location of the pair of endpoints for a bandwidth optimization "session". In this manner, bandwidth optimization is only performed where it is really required, on the narrow-band, point-to-point link.

Figure 6-11 shows the protocol stacks at the relevant nodes in the network for an MPLS-based transport solution over a routed domain. On the downlink, UDP/IP packets are mapped onto MPLS paths at the RNC, and are sent uncompressed through the network to a compressing/decompressing node (CDN). The UDP/IP packets are then compressed using a technique defined in clause 6.2.4.5.1, and sent compressed over the narrow-band point-to-point link. At the Node B the UDP/IP packets are restored/uncompressed. On the uplink, UDP/IP packets are compressed and sent over the narrow-band link. At the CDN, packets are uncompressed and mapped onto an MPLS path for transport to the RNC. Because the MPLS label attached to the compressed packet is used to route the frame through the network, the CDN can be located at the RNC or at any point along the path to the Node B that has sufficient processing capacity for handling the CDN functions.

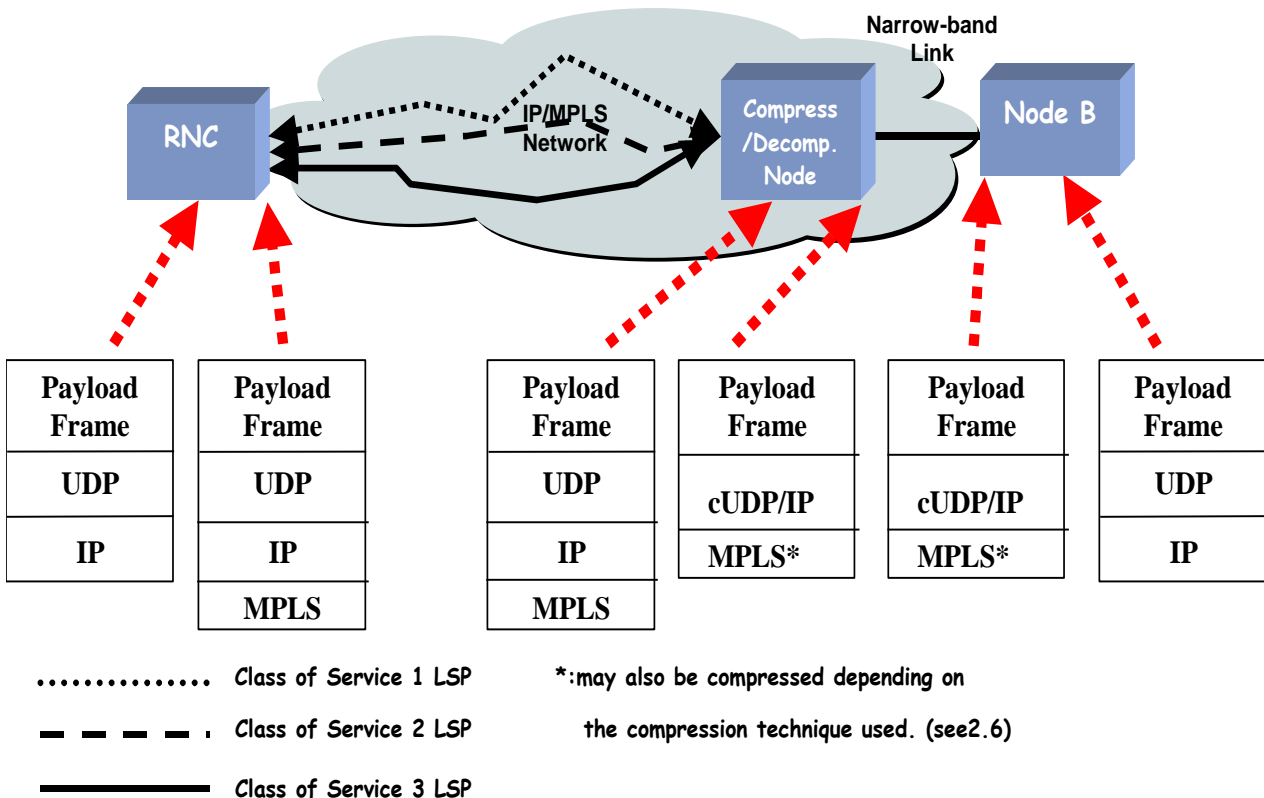

Figure 6-11: Protocol stacks at key nodes in the network for a MPLS-based transport solution

An MPLS-based transport solution for the UTRAN, integrated with DiffServ (or DiffServ-like) mechanisms, includes the following:

- Label-Switched Paths (LSPs) are established between an RNC and a Node B, in both directions; each LSP carries one or more class of service supported by the UTRAN. This occurs during NodeB initialization, before user traffic is allowed to flow through the NodeB. LSPs can be pre-setup via provisioning (e.g., using COPS MPLS [40]), or set up dynamically using CR-LDP [37] or RSVP-TE [38]. As part of this process of setting up the LSPs, all the intermediate transit routers are provisioned to provide the desired per-hop behaviour (i.e., scheduling treatment and in some cases, drop precedence for each DS code point). By providing consistent behaviour to packets belonging to the same class of service in each transit node which is part of an LSP, the overall quality of service in that LSP is achieved. This is consistent with the approach described in [31].
- The operator decides how many classes of service there will be supported in the UTRAN, and also how classes of service map to an LSP (i.e., one or more).
- An IP packet is mapped to the LSP with appropriate class of service based on two things: the DS code point marking in the IP header of the packet, and the FEC that the packet belongs to, (i.e. the destination IP address in the IP header). This is also consistent with [31].
- IP packets are mapped to the appropriate LSPs at the UTRAN edge nodes, i.e., the RNCs and Node Bs.

#### 6.2.4.5 Efficient transmission over narrowband (point-to-point) links with MPLS

Compression of UDP/IP headers is compatible with the use of MPLS in order to provide optimized efficiency on narrow-band links. As an example, two types of techniques are currently under investigation over PPP links and available as internet drafts:

- "simple IP header compression" [34] where the emphasis is put on the flexibility on the point where the compression and decompression nodes are located: compression can be performed between any two LSRs on the LSP including compressing over the complete LSPs. In that case the compressed frame is routed through the LSP with the MPLS label. This technique is based on differential coding compared to a static template which presents the advantage of robust synchronization between compressor and decompressor even in case of lost frames. The bandwidth efficiency calculation leads to overheads (layer 2 + layer 3) of 9 bytes per user flow.
- "MPLS+IP Header compression" [39] where the compression is only performed on a point-to-point link (such as UTRAN last mile) and the emphasis is further put on MPLS header compression. In that case, the MPLS label is compressed by sharing the UDP/IP compression context. Bandwidth efficiency is further improved by using the same differential coding as introduced in [40]. This differential coding scheme transmits the changes between successive packets in order to keep the size of the compressed fields small. The resulting overhead (layer 2 + layer 3) is 7 bytes per user flow.

The detailed calculations and the comparison of bandwidth efficiency on the last mile for the different alternatives is addressed in the document [40]. The optimization between the two techniques could be left to network engineering.

Header compression also implies a previous negotiation between the compressor and decompressor. As an example, the following clause describes how this negotiation is performed for one of the above defined compression techniques over PPP [34]. The equivalent for the second one can be found in [41].

##### 6.2.4.5.1 MPLS Header Compression "Session Negotiation"

As with other header compression techniques, a header compression session negotiation is required. Here are two examples of how this can be done:

- using RSVP-TE messages to negotiate the header compression [34], or
- using the Label Distribution Protocol (LDP) to negotiate the header compression.

A fundamental concept in MPLS is that two LSRs must agree on the meaning of the labels used to forward traffic between and through them. This common understanding is achieved by using a set of procedures, called a label distribution protocol, by which one LSR informs another of label bindings it has made.

The Label Distribution Protocol, LDP [8] describes one of the label distribution protocols, by which LSRs distribute labels to support MPLS forwarding along normally routed paths. An extended version of RSVP [38] can also be used to define and distribute labels.

#### 6.2.4.5.1.1 Using RSVP-TE to negotiate "MPLS Simple Header Compression"

The internet draft "Simple Header Compression" [34] describes a way of negotiating a MPLS Header Compression session using RSVP-TE signalling. The compressor endpoint sends an RSVP PATH message to request an MPLS header compression session. The decompressor replies with an RSVP RESV message confirming that it will perform the decompression.

The compressor includes a SIMPLE\_HEADER\_COMPRESSION (SHC) RSVP object in the PATH message to communicate the header template and the set of operands. To allow multiplexing across an LSP the SHC objects also carry a one byte sub-context ID (SCID).

The decompressor includes a SIMPLE\_HEADER\_COMPRESSION\_REPLY RSVP object in the RESV message to indicate which SCIDs it is agreeing to decompress.

The template in the SHC object consists of the first n bytes of a packet. All of the fixed fields are set to their appropriate values. The variable fields are set to zero. Fields are always delimited on byte boundaries. Each operand is simply an offset and a length. They serve to delimit the variable fields within the template.

Instructions on what to do with the variable fields (e.g., IP TTL, IP checksum, and IP length) is also signalled in the SHC object, using the T, C, and L flags, respectively.

The compressor removes the header from the packet. The term header is used loosely here. It refers to the first n bytes of the packet where n is the length of the header template. The compressor uses the operands to extract the variable fields from the header. These are concatenated together as a compressed header. The SCID is then prepended to the compressed header and the packet is sent.

The decompressor uses the incoming MPLS label and the SCID to locate the proper decompression context. The decompressor then uses the header template to reconstruct the original header. It uses the operands to populate the variable fields of the header with the contents of the compressed header.

Over the life of an RSVP session SCIDs may be added and deleted simply by refreshing the Path state with the updated set of SHC objects. The SHCR object provides synchronization between the sender and receiver as to which SCIDs may be used.

#### 6.2.4.5.1.2 Using LDP signalling for "MPLS Simple Header Compression" session negotiation

MPLS Header Compression session negotiation can be accomplished with the LDP protocol, by adding a new TLV (Type-Length-Value) that includes the header template, flags and set of operands as described in clause 6.2.4.5.1.1.

The compressor requests a label for a new IP flow (i.e., 5-tuple combination source IP address, source port, destination IP address, destination port, protocol id) via the downstream on-demand method from the decompressor, which is its LDP peer in this case. The decompressor provides the MPLS label it wants to use for this FEC back to the compressor. The decompressor also stores the mapping of MPLS label to header template+flags+operands in a local table. The compressor also specifies how the IP TTL, IP checksum, and IP length fields are to be regenerated on the other end in the FEC TLV.

The compressor LSR can then compress the IP packets as per clause 6.2.4.5.1.1. When the decompressor LSR receives the MPLS frame, it looks up the MPLS label in the mapping table, and uses this information to restore the UDP/IP header.

#### 6.2.4.5.2 Handling of large packets over narrowband links

In general, sending a large packet over a narrowband link will cause delays to subsequent real time packet(s) that would impact the QoS of the real time packet(s). Fragmenting large packets into smaller sub-packets, and then scheduling all the packets to be sent over a link (including the sub-packets) according to their QoS requirements generally solves this problem.

When MPLS is used in a UTRAN transport solution, the fragmentation can be localized over the narrowband link by relegating it to the underlying layer 2:

- ATM can provide this with AAL-5;
- Multi\_Link PPP can provide this [20];

- Multi-class extension of Multi-Link PPP can provide this [21];- HDLC can provide this with PPP in a Real-time Oriented HDLC-like Framing [35];
- Frame Relay can also provide this [33].

## 6.2.5 AAL2 based solution

If it is determined by RAN3 that a protocol should be used for multiplexing and/or fragmentation between the IP layer and the RNL, the AAL2 (SSSAR and CPS) user plane protocol should be used over UDP.

AAL2/UDP should be used for multiplexing and fragmentation between the IP layer and the RNL for the following reasons:

- 1) Using AAL2 makes interoperability between IP and AAL2/ATM nodes easier.
- 2) Fragmentation and multiplexing standards already exist.
- 3) Fewer protocols need to be supported in a UTRAN node.
- 4) AAL2/UDP will be terminated in the UTRAN end node.

Some changes could be made to the existing AAL2 protocol:

- 1) It is not necessary to limit the UDP packet size to 48 bytes as it is for ATM.
- 2) There is no reason to split an AAL2 SDU between two UDP packets as is done with ATM. As a result there should be no reason for the AAL2 Start field.

## 6.2.6 Usage of UDP Lite for IP UTRAN

[Editor's note: This clause refers to deleted or expired ietf-drafts]

### 6.2.6.1 Background

There are a number of link technologies where data can be partially damaged. Microwave transport is one common example. For some applications, such as voice, better performance can be achieved if errored data is not discarded but is instead delivered to the application.

The current ATM UTRAN allows bit errors in the payload to be passed to the application. This is because:

- ATM only protects the ATM header with a Header Error Control (HEC) field.
- AAL2 only protects the AAL2 header with an HEC field.
- AAL2 also provides support for error detection for the payload in I.366.1. This is not used in the UTRAN, however.
- The UTRAN framing protocols include a checksum for the headers and an optional checksum for the payload.

In Ipv4, the UDP checksum either covers the entire datagram or is not used at all. In Ipv6, the UDP checksum is mandatory and can not be disabled. The Ipv6 header does not have a header checksum so the UDP checksum was made mandatory in order to protect the IP addressing information. This means with classic UDP the entire packet must be covered for Ipv6.

It would be beneficial if the error detection mechanism of the transport layer could protect vital information such as headers and to optionally ignore errors best handled by the application.

However, as it is recognized that the probability for a well-designed link to add errors is very low ( $<10^{-6}$ ) for most of the time, it is not envisaged a real need for the use of the UDP-lite in IP UTRAN.

### 6.2.6.2 UDP Lite

UDP Lite is an IETF Working Group draft. It provides a partial checksum that improves the flexibility over classic UDP by making it possible to define the part of a packet to be protected by the checksum.

The UDP Lite header is shown in the figure below.

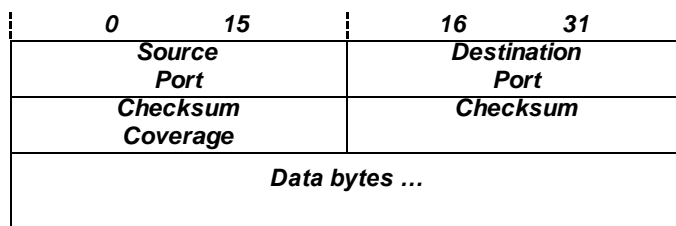

Its format differs from classic UDP in that the UDP "Length" field has been replaced with a "Checksum Coverage" field. Information about the UDP Lite packet length can be found in the length field of the IP header so the packet length information in UDP is not required.

The fields "Source Port" and "Destination Port" are the same as classic UDP (RFC-768) [42].

"Checksum Coverage" is the number of bytes that are covered by the checksum beginning with the first byte of the UDP Lite header. A "Checksum Coverage" of zero indicates that the entire UDP Lite packet is included in the checksum.

"Checksum" is a checksum over a pseudo-header of information from the IP header and the number of bytes specified by the "Checksum Coverage". The same pseudo-header from the IP layer used in classic UDP for inclusion in the checksum calculation is also used for UDP Lite.

UDP Lite has its own protocol number that is different than the classic UDP protocol.

## 6.3 QoS

This study area is related to the QoS mechanisms that may be in the upper layers. For example, an IP stack may use the IETF diffserv mechanisms to effect QoS. However, Diffserv provides the tools but does not define the policies of the QoS architecture. For example, QoS must be provided for individual user services, and packets must be marked accordingly.

At IP layer, Diffserv, RSVP or over-provisioning may be used.

In the UTRAN there are three planes involved, the User plane, the Control plane and the Management plane. Though the characteristics of the users in these planes differ (PDU size, QoS requirements, etc.), they are all sharing the same transmission and potentially interfering each other. Additionally non-UTRAN traffic will also share the transmission network. That non-UTRAN traffic can not be excluded from the IP transport network, as it could be one reason why a operator chooses IP as transport technology.

When evaluating any mechanism, one should consider its applicability for all three planes and the non-UTRAN traffic. This approach enables a unified basis for the QoS and for the efficient utilization of transport resources.

In an IP network, the deployment of QoS features is not sufficient to ensure guarantee of service. The network shall be correctly dimensioned, so that the expected service can be provided. The provisioning of resource must be done with some over-dimensioning factor depending on the maximum packet size. The bigger the real-time packets, the more resource will be necessary.

NOTE: That reason is basically the same that justifies small cell size in ATM, to provide QoS.

### 6.3.1 Fragmentation

#### 6.3.1.1 General

Fragmentation is required to adjust packets to the Maximum Transmission Unit (MTU) size of the path, and, for slow links, to prevent short, time sensitive packets from being delayed by large packets in front of them on a link. For example, with a rate of 384 kbps and a TTI of 80 ms a data payload size of 3 840 bytes will result. The RLC might segment this data but all the segments (transport blocks) are multiplexed into the same packet (transport block set).



Fragmentation must be performed also on the non-UTRAN traffic, if any, or the network must be oversized. The typical packet size density derivation of www traffic has its peaks at 64 Byte and 1500 Byte. A 1500 Byte packet introduces on a E1 link the jitter of 6,25ms.

### 6.3.1.2 IP fragmentation

IP fragmentation is the capability of the IP protocol to fragment a packet into multiple segments based on the Maximum Transmission Unit (MTU) size of the path the packet will traverse. The MTU of the path can be "discovered" using MTU path discovery which involves sending an ICMP message over the path and receiving the smallest MTU discovered along the path. If the packet is larger than the path MTU, it will be fragmented. The MTU is set in a router based on the link characteristics.

For PPP, the MTU size is flexible. For Ethernet links the maximum and default MTU is 1500 bytes. For Gigabit Ethernet a 9000 byte frame size possible (Jumbo Frames).

Disadvantages of IPv4 fragmentation are:

- 1) Bandwidth efficiency with larger packets is not realized in the part of the path with larger bandwidths since once a packet is fragmented it can only be reassembled at the endpoint.
- 2) For IPv4, IP header compression cannot be used. This is not the case for IPv6.
- 3) For IPv4, the overhead is large when IP fragmentation is used. Also, fragmentation can be performed at any link along the path. This can result in heavy processing demands on the routers in the network. IPv6 fragmentation is only allowed end to end.

End-to-end fragmentation, whether using IP fragmentation or fragmentation above the IP layer ("application level" fragmentation), can be used to adjust the packet size to the path MTU but is not suitable to solve issues around a slow link. This is because IPv6 allows the MTU to be set to a minimum of 1280 octets which is not small enough for slow link issues.

Since the disadvantages of IP fragmentation are not relevant when performed end-to-end, IP fragmentation would be supported in the UTRAN nodes to adjust the packets to the path's MTU. It should only be done end-to-end for both IPv4 and IPv6. Also, the network should be designed such that MTU sizes are not so small that the IP headers consume too much bandwidth. This is the same approach taken for the GTP protocol and assumes that the operator has some control over the network.

IP fragmentation would not be used to facilitate delay-sensitive traffic on slow links. Layer 2 mechanisms would be used for this as indicated in the IPv6 RFC [27]:

"IPv6 requires that every link in the internet have an MTU of 1280 octets or greater. On any link that cannot convey a 1280-octet packet in one piece, link-specific fragmentation and reassembly must be provided at a layer below IPv6".

### 6.3.1.3 Fragmentation to facilitate delay sensitive traffic

In order to facilitate delay sensitive real time traffic, large packets can be segmented and the segments can be mixed with the higher priority traffic. This is only relevant for slow speed links where any delays can effect the performance of the applications.

IP fragmentation does not automatically address this problem since IP fragmentation only fragments based on the size of packet that a link can handle. This packet size may not be small enough to allow the efficient use of the link when delay sensitive traffic is present. It could be possible for IPv4 networks to set the MTU of the link to a smaller size than necessary to facilitate delay sensitive traffic. However, this can effect the efficiency of the higher speed links along the path. IP fragmentation is always end to end for IPv6.

### 6.3.1.4 Application level fragmentation

Application fragmentation can help with avoiding IP fragmentation but does not automatically solve the problem for efficiency over slow links. MTU discovery can be used to determine the size of packet required to avoid IP fragmentation but it does not provide the necessary information required to know what packet sizes should be used for efficiency over slow links. It is possible that this size could be configured based on knowledge of the slow links but this affects the processing and routing efficiency over higher speed parts of the transport network

### 6.3.1.5 Layer 2 fragmentation solution

In general, it is best to take care of slow link problems only over the slow link and not over the entire path. One alternative is to handle segmentation as a lower layer issue. As an example, for PPP, the fragmentation capabilities in multilink PPP [20] can be used for this purpose. With multiclass extensions, multiple flows can be identified within a PPP stream. The IPv6 specification says that for links that cannot convey a 1280 octet packet in one piece, link-specific fragmentation and reassembly must be provided at a layer below IPv6.

Layer 2 fragmentation provides flexibility because it does not need to be end-to-end. It can be multi-hop using tunneling in which case it is more flexible than application level and IP fragmentation.

### 6.3.2 Sequence information

If fragmentation is provided between IP and RNL, then a sequence number is required in order to reassemble the fragments.

Many of the Radio Network frame protocol specifications say that the transport layer must deliver frames in order. However, it is part of the IP UTRAN investigation to determine if this is actually a valid requirement.

If it is shown that a sequence number is required then this functionality could be provided between the frame protocols and the IP transport layer (i.e. UDP).

### 6.3.3 Error detection

AAL2/ATM has the following error detection capabilities:

- 1) ATM provides no error detection capability for the payload, but only for the ATM header.
- 2) AAL2 provides error protection for the header using the HEC.

IP has the following error detection capabilities:

- 1) The link layer can protect the payload. Examples are the HDLC and the AAL5 checksums.
- 2) UDP has an optional checksum for IPv4 that is mandatory in IPv6.

Therefore, for AAL2/ATM no error checking is performed on the payload. For IP, error detection capabilities are provided at the link and transport layer. Whether additional error checking is required above the UDP layer is FFS.

### 6.3.4 Flow Classification in IP Networks

Once these QoS classes have been defined and the respective priorities or requirements set, it shall be possible for UTRAN traffic to be recognized as pertaining to each of the individual classes, so that transport nodes can deliver appropriate QoS. Therefore nodes implementing Transport function are not only responsible for differentiating service among a set of IP packets but also to classify those IP packets to be able to deliver the respective QoS.

NOTE: Differentiation has a larger meaning than *DiffServ* acceptance. Even in *IntServ* model, IP packets are differentiated according to flow filtering, i.e. they receive different services according to established reservations.

Classification can basically be realized according to specific layer information, such as header field values or context information. One can distinguish between Radio Network Layer and Transport Network Layer based classification.

#### 6.3.4.1 Classification based on RNL information

For instance, SRNC knows about relative and absolute QoS requirements for RABs and can base its transport differentiation on RNL information based classification. It is an implementation issue only how this can be done, but it is very easy to realize thanks to additional information in layer to layer primitives.

In DRNC and Node B, such a classification can be envisaged if relevant RNL information is available. However QoS requirements as extensive as RAB parameters may not be available in those nodes.

RNL information is assumed to be unreachable in intermediate transport nodes that are UTRAN agnostic. In those nodes, classification can only be done with standard or classical IP methods.

#### 6.3.4.2 Classification based on TNL information

Various QoS models and solutions exist for IP networks, with specific advantages and best uses. However they have common features that they all need to realize, like flow classification. Instead of listing all QoS solutions, this clause limits to information commonly used to classify IP flows to provide QoS:

- IP ToS (Type of Service) field can be used to classify among some traffic classes. This field is used in core DiffServ routers to deliver Per Hop Behaviour (so called Behaviour Aggregate Classifier).
- L3/L4 fields: IP header and Transport Protocol (UDP, TCP, and SCTP...) contain additional fields that can be used to classify among IP packets. Most commonly used fields are IP addresses, Transport Protocol ports and Protocol Identifier of IP header. Those classifiers are called Multi-Field Classifiers.
- MPLS label can also be used to distinguish among separate FEC (Forwarding Equivalence Class), even if they share a common destination.
- MPLS EXP (Experimental) bits are also proposed to be used to provide flow classification on a granularity similar and compatible with DiffServ model.

Input interface can also be used when classifying packets.

#### 6.3.5 Classification Configuration

Classifications presented in 6.3.4.2 are relevant in the Transport Network Layer only. Nevertheless, they shall be defined according to UTRAN QoS requirements and to RAB classes, since those requirements are known by RNL.

Such a mapping can be done:

- at Transport bearer selection, when deciding transport bearer end point addressing that can later be used to classify the flows (e.g. IP, UDP addresses directly or mapped on MPLS label);
- at UTRAN flow source (Node B, RNC) on a packet per packet basis, by assigning the relevant TOS field, EXP field or by encapsulating in the relevant MPLS label.

Both methods offer different characteristics that are detailed hereafter.

##### 6.3.5.1 Transport bearer based classification

Transport Bearer based classification can be very fine but impose intermediate node to be aware of part of or all end point addressing. This is needed to create filters based on this information in intermediate nodes.

This knowledge of transport bearer addressing by intermediate transport nodes can be:

- signalled for each individual transport bearer, but it would need non-scalable and complex signalling like RSVP;
- pre-configured with semi static classification filters based on partial transport bearer addressing information, e.g. source UDP port, destination IP address etc. With such an alternative, intermediate transport nodes need not to be signalled at transport bearer establishment of particular filtering for the new bearer. Intermediate nodes can either be configured by O&M or by aggregate RSVP reservations.

Moreover, if the classification is based on destination information only, the source node may be unaware of classification. It does implicit classification ruled by destination node at transport bearer termination selection.

##### 6.3.5.2 Packet per packet classification

If QoS is marked in source node by relevant tagging in IP or MPLS headers, filtering in intermediate node is simpler. The classification in intermediate transport nodes does not depend on end node transport addresses and therefore is simpler to configure and manage.

On the other hand, the granularity may be coarser if only ToS or EXP bits are available to distinguish between traffic classes.

### 6.3.6 UTRAN Hop-by-Hop QoS Approach

This approach relies on the QoS differentiation, which is provided by the IP backbone. This means the UTRAN internal flows (e.g. RAB traffic, NBAP signalling, ...) have to be mapped to the IP network. This mapping is not obvious because of the specific properties of UTRAN traffic. Due to the fact that the RLC/MAC layer are on RNC side, even the best effort RAB QoS class becomes time constraint traffic in UTRAN, but with more relaxed delay requirements than the conversational RAB QoS class. The delay requirements themselves are dependent from the MAC strategy in the RNC, which is manufacturer dependent.

QoS differentiation in the IP backbone could be provided by Diffserv for example. Scheduler algorithms and strategies from the installed routers are used and must be configured to meet the UTRAN requirements.

The last mile between the edge router and a NodeB is assumed to be a bottleneck for all UTRAN traffic flows. The adaptation to the low speed link has to be done by L2 techniques. Advanced functions like QoS differentiation, segmentation and multiplexing are needed in L2. For example, the PPP protocol is a meaningful candidate for this adaptation. It provides with its extensions Multi-Class PPP and PPPmux the required QoS differentiation, segmentation and multiplexing functionality.

However, still some issues need to be solved:

- a mechanism shall be defined to inform the edge router about the needed quality classes towards the NodeB and the parameters used for the differentiation;
- it shall be defined on which edge router functionality the standard design relies on, and what can remain implementation dependent;
- the interworking of PPPmux with MC-PPP should be defined, for instance the availability of a separate PPPmux instance per QoS class shall be clarified.

### 6.3.7 UTRAN End-to-End QoS Approach

The end-to-end approach provides QoS differentiation for the UTRAN traffic flows inside the UTRAN NEs. User plane protocol proposals like CIP and LIPE rely on this principle. But also the PPPmux based proposal can provide an e2e approach by tunnelling the PPP protocol via L2TP (TCRTP). The queuing and scheduling is performed inside the NEs under control of the UTRAN equipment manufacturer. In the IP backbone only one QoS class is needed for UTRAN traffic, which could be the expedited forwarding (EF) class of Diffserv.

The QoS differentiation is simpler because the quality classes are well known inside the NEs and the complex management function to distribute the QoS parameter in the IP network can be avoided.

However, for the implementation dependent O&M traffic the head of line blocking problem still exists. In case the edge router provides on data link layer only one QoS class, IP fragmentation at the O&M center could be configured to a reasonable IP packet size. If the edge router provides at least two QoS classes (ML-PPP) the best effort O&M traffic could easily be distinguished from the tunnel carrying the other UTRAN traffic.

## 6.4 Transport network bandwidth utilization

This study area is related to bandwidth efficiency by e.g. multiplexing/header compression, resource management, and the use of segmentation. Lower speed links, such as E1, or shared higher speed links may require different techniques (e.g. header compression and multiplexing) than dedicated higher speed links.

When evaluating and comparing efficiency of different candidate schemes for efficient bandwidth utilization, their impacts on the other study areas of this chapter have to be identified and considered.

## 6.4.1 General issues

### 6.4.1.1 Multiplexing

Multiplexing provides a means for reducing the impact of the size of the UDP/IP headers in a packet. It is important for gaining better bandwidth efficiency with small packets. Multiplexing can be performed at the application layer or a lower layer. An example of application level multiplexing would be if the length field in the GTP header would be used to delimit GTP tunnels multiplexed within one UDP/IP packet. This is not currently supported in GTP. Application level multiplexing reduces the impact of the IP and UDP headers. However, when header compression is applied, the overhead is already significantly reduced.

Multiplexing within a PPP frame is being addressed currently in the IETF [10]. Advantages of PPP multiplexing are:

- 1) Layer 2 multiplexing provides the possibility for routing multiplexed packets using tunneling as does application level multiplexing.
- 2) Layer 2 multiplexing is not end-to-end so how multiplexing is applied at the source does not need to be based on the worst case link in the path.
- 3) Packets with different IP addresses can be multiplexed in same PPPmux frame. With application level multiplexing, only packets going to same IP address can be multiplexed.

#### 6.4.1.1.1 Location of multiplexing in transport network

Three architectures are proposed for multiplexing distribution in transport network, as depicted in figure 6-12. They are presented and discussed hereafter.

##### 6.4.1.1.1.1 Scenario 1:

Multiplexing is done end-to-end, i.e. transparently to intermediate transport nodes. This solution has the benefit of simplicity regarding intermediate transport nodes that may be multiplexing agnostic.

Some limitations can be noted for this scenario:

- All information multiplexed in one packet shall follow the same path and shall be serviced with the same QoS, since intermediate transport nodes are multiplexing agnostic.

However it is still possible to handle differentiation in end nodes and to take benefits of several QoS in the transport network: there is only the restriction that all information in one packet cannot be serviced differently, once they have been multiplexed.

As far as the routing/path is concerned and considering current RNL architecture, Node B has only one Iub interface towards one C-RNC and therefore it is not a requirement to allow multiplexing of information having different destinations.

- Both aspects of multiplexing as introduced above in 0 cannot be distinguished. Therefore they cannot be optimized separately.

Nevertheless, since low speed link multiplexing is the most important aspect, it can be the basis for optimization.

As a conclusion, scenario 1 has some limitations but it can provide simple transport network solutions, since it needs only basic functionality in transport network intermediate nodes.

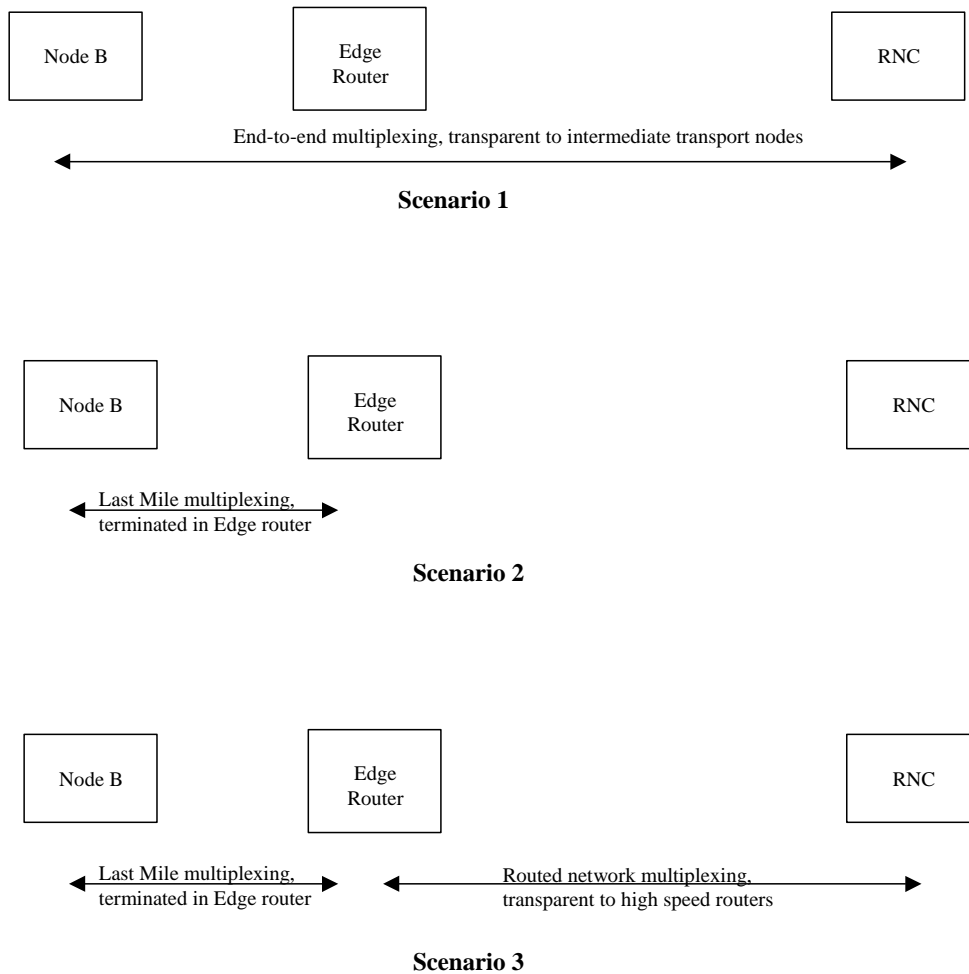

**Figure 6-12: Scenarios for multiplexing location**

6.4.1.1.1.2 Scenario 2:

Multiplexing is on last mile low speed links only, where bandwidth is a limiting factor and where high-speed interface resource optimization is not required. It provides functionality on the exact network portions that require efficiency.

Hereafter are the characteristics of this solution:

- This scenario induces some functionality in edge router to terminate the multiplexing.
- Downlink packets arrive in the edge router and shall be multiplexed and differentiated according to some knowledge of QoS. Therefore the edge router shall participate in QoS differentiation and end-to-end differentiation is not sufficient.
- Packets multiplexed together on the uplink/downlink can be forwarded to/from different paths with different QoS after the edge router. This brings flexibility, with some complexity in the transport network.

Therefore scenario 2 is more flexible and optimal, with more complex QoS handling in transport network and higher processing power per packet in the edge router. It does not cover the multiplexing on high-speed interfaces for reduction of number of packets per second.

6.4.1.1.1.3 Scenario 3:

Scenario 3 can be considered as an extension of scenario 2 for high speed link multiplexing.

There are indeed two multiplexing "sessions", one between Node B and edge router and another between edge router and RNC. The first one is very similar to the one described in scenario 2. The second one is presumably routed with less stringent bandwidth requirement.

It can be expected that sufficient concentration exist between edge router and RNC to allow several sessions towards several RNC. Therefore the edge router is really doing routing of individual information payloads of both types of multiplexing sessions: it de-multiplexes on one side what it receives and re-multiplexes on the output interface.

### 6.4.1.2 Resource Management

The solution for resource management should be scalable in complexity. It should also allow traffic other than UMTS traffic without seriously degrade the quality of service of the UMTS traffic. Some operators will require IP connectivity for other applications using the same network as the UTRAN. The use of VPNs can be investigated in order to facilitate the sharing of network resources. Resource management setup time should be minimized such that it meets the requirements but does not add too much delay for the application connection setup.

For the low-speed links, delay needs to be well controlled for soft handover and other time critical operations. Also, since these interfaces are part of the network where resources are more expensive, it's particularly important to utilize the bandwidth in an efficient way. In addition, where node synchronization messages are used, they must have small delay in order to be effective. For these reasons the use of on-demand resource allocation should be given particular consideration.

Static routing or dynamic routing using a routing protocol could be used. Static routing allows easier control over delays but puts heavier requirements on configuring the network. Dynamic routing protocols add complexity but increase the possibilities for automatic configuration.

The following possible functions relating to resource management should be considered:

- Admission control: Enforces a limited load within a traffic class in order to limit the delay caused by buffering in network routers.
- Policing: Once traffic has been admitted in a network based on certain traffic characteristics, it may be policed to ensure that it does not violate the conditions of its admission.
- Reservation of resources: How should resources be reserved in the transport network?

Allocation of resources can be static or dynamic. It can also be performed by one or a combination of several methods, for example:

- Over-provisioning: This method is static and there is no need for admission control. However, it does not take advantage of transport bandwidth efficiency gains that IP can provide.
- Allocation of aggregates of flows (a trunk). This can be dynamic but changes of bandwidth allocation are made more slowly than per flow allocation.
- Allocation per flow: Allocation of resources is made on a per call basis.
- The admission control function can be centralized or distributed:
  - With server based admission control, resource requests are made to a server. A centralized or partly distributed server architecture can be used.
  - Distributed admission control uses signalling (e.g. RSVP). The admission control function is distributed in the routers and is performed hop-by-hop. RSVP could have scalability problems for large networks if it is used per flow.

### 6.4.1.3 Header Compression Techniques

#### 6.4.1.3.1 Technical evaluation

In this technical evaluation, only UDP/IP flows are considered.

#### 6.4.1.3.1.1 Use of Differential Coding

The standard compression techniques can be partitioned in two classes of techniques whether the differential coding is used or not:

- The first one does not use differential coding: each compressed packet sent contains the randomly changing fields of the header in the compressed header so that the compression context is only updated by full header packets (a.k.a. templates).

Here the decompressor gets out of sync only when a full header packet changing the context is lost. It does not get out of sync when simple compressed packets are lost or full header packets not changing the context.

Moreover, it features quick recovery from out of sync. The full header packet is sent initially and can be resent periodically. Some parameters can be tuned to upper bound the period of disconnection.

RFC 2507 [51] uses this class of techniques for compressing UDP/IP packets. This is named `compressed_non_tcp`.

- The second one uses differential coding: each compressed packet does not send the fields that have constant first order differences. Thus each compressed packet is used to update the context information at the decompressor. Therefore, each lost compressed packet causes the compression context to become out of sync, so the decompressor must request a full header packet from the compressor in order to re-sync.

This class of techniques is designed to work over a point-to-point link: the issue being that, if the compressor and decompressor are more than a link apart, the compressed packets must be tunnelled, and then the delay in re-syncing the two increases.

RFC 2508 [13] uses this class of techniques for UDP/IP flows. This is named `compressed_udp`.

#### 6.4.1.3.1.2 Comparison

RFC 2508 [13] differentiates from RFC 2507 [51] by being optimized when RTP is used on top of UDP/IP. It provides specificities for RTP support and most of all the RTP header strongly benefit from differential coding since it has many fields which are constant at the first order.

When simply used over UDP/IP without RTP on top as for IP-based UTRAN transport, the differential coding produces marginal bandwidth gain on UDP/IP header. To that respect it can be said equivalent to RFC 2507 [51].

To the opposite, RFC 2507 [51] is much more robust against the loss of packets. Because it does not use second order differences, the loss of one compressed packet does not get the decompressor out of synchronization. This means that some real time packets will not be dropped waiting for a resync to be performed, to the detriment of voice quality.

#### 6.4.1.3.2 UTRAN Evaluation

UMTS decided to support RFC 2507 [51] for PDCP (3GPP TS 25.323). TS 25.323 specifies RFC 2507 [51] as the protocol being operated according to clause 3 of the IETF specification RFC 2507[51] and to use the mechanisms related to error recovery and packet reordering as described in clauses 10 and 11 of RFC 2507 [51].

The clause 5.1.2.2 clearly includes the `compressed_non_TCP` as part of the Protocol Identifiers.

So, for the benefit of reusability, since it is the one selected for PDCP, RFC 2507 [51] should be preferred.

#### 6.4.1.3.3 Use of Negotiation

The IPHC over PPP as defined in [14] describes an option for negotiating the use of IPHC on IP packets in PPP links. The Header Compression itself is based on the IPHC but [14] allows the negotiation of its use over PPP control protocol. To ensure multivendor operability of the interface, the use of negotiations is encouraged.

### 6.4.2 Solution Comparison data

Preliminary simulation results for MPLS, LIPE and PPPMux indicate that in general, comparison of capacity performance of the different multiplexing protocols alone is inconclusive. Other criteria must be used in order to select one protocol over another.



## 6.5 User plane transport signalling

The use of IP based protocols for the user plane mandates compatible signalling in the control plane. The signalling must accommodate the appropriate mechanisms to specify, establish, and manage IP streams as opposed to virtual circuits/connections. Signalling for IP bearer exchanges transport bearer identifiers, (e.g. IP addresses and UDP port numbers) for each end of the bearer stream. If there is a need for user plane connections, it should be investigated how connections between UMTS nodes should be handled. It should be investigated whether an ALCAP protocol is required.

### 6.5.1 Solution without ALCAP

#### 6.5.1.1 Principle

Unlike Iu-cs, Iu-ps does not require an TNL signalling protocol to establish/maintain/release user plane Transport Bearers.

The transport bearer termination points, at CN and UTRAN sides, are identified by Information Elements carried by RANAP messages [3]:

- Transport Layer Address IE: This information element is an IP address to be used for the user plane transport. It generally corresponds to the IP address of the board that processes GTP-u for the RAB to be established.
- Iu Transport Association IE: This information element is the GTP Tunnel Endpoint Identifier.

These fields are coded as bit strings or octet strings. They are transparent to RANAP i.e. to Radio Network Layer (RNL), and are only seen by the Transport Network Layer (TNL).

The reason for not using ALCAP in the PS domain is linked to the connectionless aspect of IP layer.

ALCAP protocol is needed for the case there is a TNL switch between two RNL nodes, since RNL protocol (RANAP on Iu, RNSAP on Iur, NBAP on Iub) does not terminate in the TNL switch (e.g. AAL2 switch). This is shown in figure 6-13.

In the case of IP networks, destination IP address is sufficient to route an IP packet to the TNL termination point.

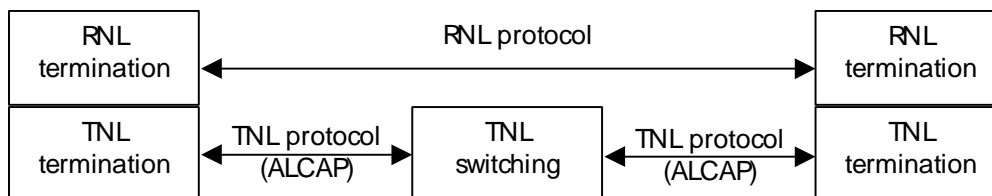

**Figure 6-13: RNL and TNL terminations**

When IP is used as transport in the UTRAN, it is therefore possible to avoid the use of a TNL protocol (i.e. ALCAP) on Iur and Iub while keeping the independence between RNL and TNL. Avoiding the use of a TNL protocol results in benefits with regards to e.g. connection set-up delays.

Similarly to Iu-ps, it is proposed to exchange Transport Bearer termination point identifiers via the RNL signalling protocols over Iur and Iub (i.e. via RNSAP and NBAP).

Transport Bearer termination points can always be defined by:

- The IP address of the termination point
- The transport bearer identifier within this IP address
- Transport Bearer Characteristics.

The first two items correspond respectively to Transport Layer Address IE, Iu(x) Transport Association IE used in RANAP messages. The last item is added to carry information which is specific to the Transport Bearer and which is not interpreted by the Radio Network layer.

The contents of those fields should be coded as bit strings or octet strings in order to comply with the RNL/TNL independence: these fields are transferred to the TNL without being interpreted by the RNL.

A simple solution consists of introducing two IEs in appropriate RNSAP and NBAP messages to identify the user plane transport bearer termination points:

- Transport Layer Address IE: This information element is an IP address to be used for the user plane transport.
- Iur/Iub Transport Association IE: This information element is the identifier of the Transport Bearer at the IP address termination point.
- Transport Bearer Characteristics IE: This information element contains information specific to the Transport Bearer.

These IEs shall be transferred transparently by the RNL to the TNL.

Related RNSAP messages are e.g. RL Setup Request, RL Setup Response, RL Addition Setup, RL Addition Response.

Related NBAP messages are e.g. RL Setup Request, RL Setup Response, RL Addition Setup, RL Addition Response, Common Transport Channel Setup Request, Common Transport Channel Setup Response.

NOTE: Special attention shall be given to the fact that any unnecessary parameter dependence on the TNL type shall be avoided.

## 6.5.1.2 Solution without using additional RNL Parameters

### 6.5.1.2.1 On lub - lur

The following table summarizes the possible exchanges of parameters over the Iur and indicates when an ALCAP would be initiated.

The simple behaviour is as follows:

The very simple assumption is that a SRNC always indicates its IP capabilities if any.

The very simple behaviour is that a DRNC returns IP addressing if both DRNC & SRNC have IP capabilities, ATM addresses otherwise.

It is also based on the assumption that whenever there are the two possibilities: direct connection or via a TNL interworking, the straight connectivity is preferred.

	SRNC-DRNC	SRNC -> DRNC	DRNC ->SRNC	Comment
1	ATM-ATM	X	E.164 TLA Binding Id	SRNC initiates ATM-ALCAP IWF not required.
2	ATM-IP	X	E.164 TLA Binding Id	DRNC returns its ATM addresses since SRNC is ATM SRNC initiates ATM-ALCAP
3	IP-ATM	IP address UDP port	E.164 TLA Binding Id	The IP SRNC receives an ATM address back It initiates IP-ALCAP
4	IP – IP	IP address UDP port	IP address UDP port	<b>No ALCAP required.</b>
5	ATM – ATM&IP	X	E.164 TLA Binding Id	SRNC initiates ATM-ALCAP IWF not required.
6	IP – ATM&IP	IP address UDP port	IP address UDP port	<b>No ALCAP required.</b>
7	IP&ATM ATM	IP address UDP port	E.164 TLA Binding Id	The DRNC returns its address. SRNC has dual capabilities and knows IWF is not required using ATM. The SRNC initiates ATM-ALCAP (though IP-ALCAP could be used). IWF not required.
8	IP&ATM-IP	IP address UDP port	IP address UDP port	<b>No ALCAP required.</b>
9	IP&ATM – IP&ATM	IP address UDP port	IP address UDP port	<b>No ALCAP required.</b>

The behaviour for Iub is essentially the same as for Iur, with the Node B taking the DRNC's role.

#### 6.5.1.2.2 Inter-working on Iu

It is assumed that the CN node knows about the SRNC transport capabilities as part of the configuration package already provided (SS7 addresses, etc.).

The simple behaviour is as follows:

If both CN and SRNC have IP capabilities, the CN sends IP address & UDP port.

Otherwise, the CN sends E164 address in the Transport Network Layer Address IE and Binding ID in the Transport Layer Association IE.

In the response direction, only IP information needs to be conveyed.

The complete range of scenarios are described in the table below.

	MSC-RNC	MSC -> RNC	MSC ->RNC	Comment
1	ATM-ATM	E.164 TLA - Binding Id		RNC initiates ATM-ALCAP IWF not required.
2	ATM-IP	E.164 TLA - Binding Id		RNC initiates IP-ALCAP
3	IP-ATM	E.164 TLA Binding Id		RNC initiates ATM-ALCAP
4	IP – IP	IP address UDP port	IP address UDP port	<b>No ALCAP required.</b>
5	ATM – ATM&IP	E.164 TLA - Binding Id		RNC initiates ATM-ALCAP IWF not required
6	IP – ATM&IP	IP address UDP port	IP address UDP port	<b>No ALCAP required.</b>
7	IP&ATM – ATM	E.164 TLA Binding Id		IWF not required. RNC initiates ATM-ALCAP.
8	IP&ATM-IP	IP address UDP port	IP address UDP port	<b>No ALCAP required.</b>
9	IP&ATM – IP&ATM	IP address UDP port	IP address UDP port	<b>No ALCAP required.</b>

All scenarios have been covered without the need to introduce new IEs in the RNL.

### 6.5.1.3 Solution with higher flexibility and complexity using additional RNL parameters

Void.

### 6.5.1.4 Provisioning and Dynamic Selection of the Transport Option

This solution allows to perform load balancing and to indicate transport preferences for dual stack nodes while IP resources are progressively introduced.

#### 6.5.1.4.1 On Iub

On the Iub, the use of an additional parameter could be seen as useful to ward off some unavailability of one of the two networks (ATM, IP). This could also be envisaged during a migration phase to smoothly move from one transport technology to another.

However, since connection of NodeBs to RNCs is static and a node B has only one parent RNC this facilitates the filling of an O&M package and it is indeed very easy to add one parameter to this O&M package to inform about the dual-stack capability of a peer side, if desired, for example.

#### 6.5.1.4.2 Inter-working on Iu

It has been shown that the following behaviour described in the TR 25.933 fulfills the requirement and is very simple:

If both CN and SRNC have IP capabilities, the CN sends IP address & UDP port.

Otherwise, the CN sends Embedded E164 or AESA variant of NSAP or IP address in the Transport Network Layer Address IE and Binding ID in the Transport Layer Association IE.

In the response direction, only IP information needs to be conveyed.

This scenario without new RNL parameters only assumes that the CN node knows about the SRNC transport capabilities as part of the configuration package already provided (SS7 addresses, etc.).

Again on this interface, the O&M package already exists and therefore it is a realistic assumption here that any additional parameter can be included in the configuration package.

#### 6.5.1.4.3 Interworking on Iur

This solution allows the DRNC to make the full decision. It is to be noted that since every RNC can take the role of SRNC and DRNC on a call basis, the ability to perform load balancing is brought to every RNC. Automatic statistical regulation of transport usage is thus ensured possible.

##### 6.5.1.4.3.1 Provisioning of transport capabilities

It is assumed that an RNC is in relation with a limited number of RNC(s). Therefore it is assumed capable to know the transport capabilities by O&M. The amount of needed resources per transport technology is then provisioned for each of these interfaces. The provisioning may be the result of dimensioning or operator driven network configuration.

##### 6.5.1.4.3.2 Indicate dynamically in a signaling message the IP Transport Option Availability or ATM Preference

The originating node sends a transport information to the terminating node, so that the terminating node has all possible information for its decision for selection of the transport option.

This means that the SRNC can send either its IP address whenever it is IP capable (i.e. dual stack or IP only node) or no address at all when it wants to indicate IP resource unavailability on its side or a preference for ATM.

Sending an IP address allows the DRNC to make the full decision by indicating back its preferred transport. Thus when an ATM address is returned, ATM bearer is established. When an IP address is returned, IP bearer is established.

To the opposite, sending no address forces the DRNC to use ATM.

##### 6.5.1.4.3.3 Benefits

This Iur solution is a compromise solution that presents a lot of benefits:

- full flexibility for the receiving node (SRNC for Iu, DRNC for Iur, Node B for Iub) as it knows the capabilities of the originating node;
- the two transport options are equal;
- load sharing and operator preference (configured) could be supported;
- migration scenario fulfilled: If an operator wants to migrate a UTRAN node from ATM to IP, the UTRAN node will during a shorter or longer period of time have both transport options available and the actual switchover might be difficult to plan in advance. As soon as the ATM node becomes also IP capable during a migration phase, it can send an IP address instead of no address;
- no New IEs at all is added to the RNL.

##### 6.5.1.4.3.4 Drawbacks

This solution is based on the assumption that the usage of transport resources is symmetrical.

Thus, only one node (the DRNC) has the possibility to decide for using the IP transport option, SRNC can only decide for ATM transport.

In case of ATM resource unavailability at the SRNC, there is no way to force the DRNC to establish an IP transport bearer.

## 6.5.2 LIPE solution

[Editor's note: This clause refers to deleted or expired ietf-drafts]

When LIPE is being used for Iub/Iur User Plane traffic, there are two alternatives for user plane transport signalling. Alternative I requires no changes in the existing RNSAP and NBAP procedures but a lightweight ALCAP-like procedure is required. Alternative II introduces a new information element to Radio Link Setup Messages in RNSAP and NBAP but ALCAP is not required.

### 6.5.2.1 Alternative I Solution:

There are two steps involved in creating a communication channel between two LIPE peers. The first step is to set up a LIPE tunnel. Once a tunnel has been set up, connections for different streams may be multiplexed into this tunnel. Typical scenarios for a LIPE tunnel are illustrated in figure 6-14. In the case of point to point link, we assume that IP layer connectivity has been established using mechanisms such as PPP, ATM-AAL5 etc.

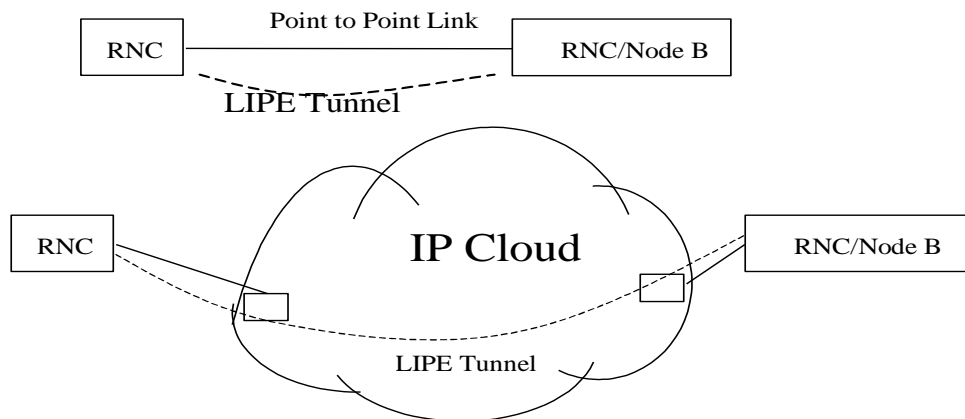

Figure 6-14: Typical LIPE tunnels in a 3GPP network

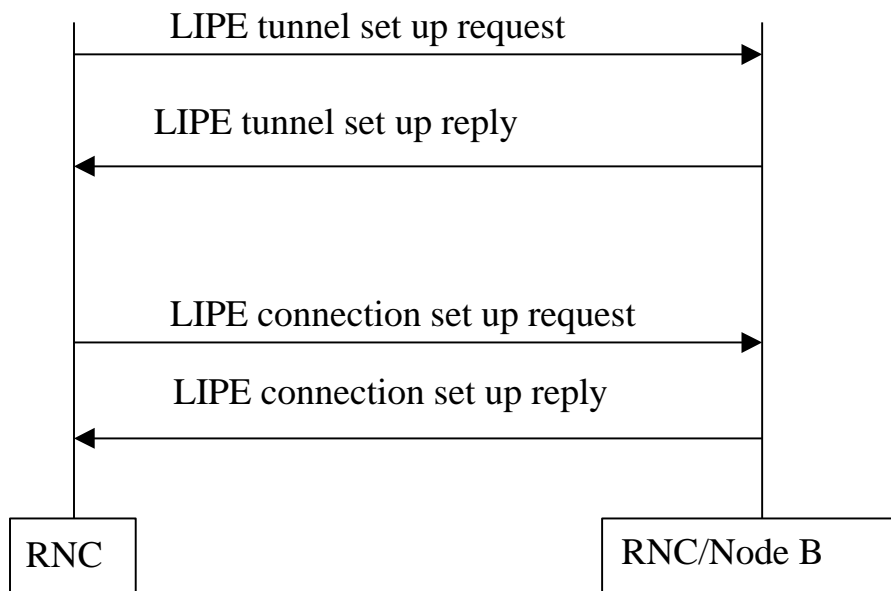

Figure 6-15: Tunnel/Connection set up procedure

### 6.5.2.1.1 LIPE Signalling Channel

A specified UDP destination port is used for the exchange of LIPE signalling messages. The format of the LIPE signalling message is given in figure 6-16.

IP (20)	UDP (8)	TYPE (4)	LENGTH (4)	Control Message Payload (20)
------------	------------	-------------	---------------	---------------------------------

**Figure 6-16: LIPE Signalling Channel Message format**

### 6.5.2.1.2 Tunnel Setup Procedure

The actual format of the tunnel setup control message payload is shown in [22].

The tunnel set up request message payload should consist of the following:

- 1) UDP destination port number for the LIPE tunnel for the reverse LIPE tunnel.

Protocols such as RSVP may be used for reservation of bandwidth resources across the path between LIPE peers for QoS guarantees. This issue is not addressed in this contribution.

A successful tunnel set up reply message should consist of:

- 1) UDP destination port number at the destination node for the forward LIPE tunnel.

A tunnel setup failure condition is triggered by a tunnel set up reply message or time out. Retransmissions of LIPE tunnel set up messages for failed tunnel set up instances should be supported.

### 6.5.2.1.3 Connection Set up Procedure

Once the tunnel set up procedure has been completed, connections for several RAB's can be set up on the tunnel. A control message type is defined for connection setup request. The actual format of the connection setup request control message payload is shown in [22]. Connection request for a LIPE connection for a RAB carries:

- 1) RABID;
- 2) Flow ID (FID).

A control message type is defined for connection setup reply. The actual format of the connection setup reply control message payload is as shown in [22]. A successful connection set up reply message carries:

- 1) Error Code;
- 2) RABID;
- 3) FID for the reverse path.

A connection setup failure condition is triggered by a connection set up reply message or time out. Retransmission of LIPE connection set up messages for failed connection set up instances should be supported.

### 6.5.2.1.4 Tunnel tear down

A control message type must be defined for tunnel tear down. The actual format of the tunnel tear down control message payload is as shown in [22]. Tunnel tear down may be initiated by either peer. The tunnel tear down message should contain:

- 1) UDP destination port for the forward tunnel (w.r.t to the peer initiating tunnel tear down).

A tunnel should not be torn down without tearing down all connections through the tunnel.

### 6.5.2.1.5 Connection tear down

A control message type must be defined for connection tear down. Connection tear down request should carry.

- 1) FID;

### 6.5.2.2 Alternative II Solution:

For the Iur interface, the procedures setting up transport bearers should be modified to include an information element for conveying the flow identifier information in the Request message. Correspondingly, the DRNC should return a flow identifier information for the reverse direction in the Response message.

Similarly, for the Iub interface, the NBAP, the procedures setting up transport bearers should be modified to include an information element for conveying the flow identifier information in the Request message. Correspondingly, the Node B should return a flow identifier information for the reverse direction in the Response message.

When Alternative II solution is being used to establish flow identifiers, ALCAP is not required.

## 6.6 Layer 1 and layer 2 independence

This study area is related to the capability to allow multiple layer 1 and layer 2 technologies.

The role of Layer 2 and Layer 1 in the QoS and/or in the transport resource efficiency needs to be considered when specifying the requirements towards L2/L1.

Requirements on L2/L1 (e.g. in sequence delivery) should be documented in the UTRAN specifications to ensure that appropriate technologies can be more easily selected.

### 6.6.1 Options for L2 specification

#### 6.6.1.1 General

The used L2 techniques may vary across the different interfaces and links. Especially, if slow links are used at Iub interfaces, specific features from the L2 protocol are required. Besides the multiplexing functionality, ML/MC-PPP [20], [21] may be required for QoS differentiation. It provides several queues, segmentation and scheduling functionality. Header compression is an other important feature which may be required to improve the efficiency.

A common case in the IP transport architecture is that the UTRAN NEs are connected to an IP router which is then responsible for the L2 termination. Supported L2 techniques have to be negotiated with the IP network provider to build an efficient TNL. It is then up to the operator what layer 2 protocols are used in the transport network.

However, also the use of point-to-point links between UTRAN NEs is a reasonable scenario. Here, no intermediate router will terminate the L2, both NEs have to implement the same L2 protocol. In a multi-vendor scenario this case may cause problems.

#### 6.6.1.2 L2 not standardized

Not standardizing any L2 will provide the most freedom for the operators to build their transport network. A variant of this approach could be to standardize some requirements for the selection of L2 to ensure that the expected functions for UTRAN TNL are provided. However, because the usage of these functions in L2 is essential to provide an efficient TNL service, they will be implemented anyway even if not required in the standard. The only issue which remains here is the multi-vendor scenario.



### 6.6.1.3 L2 standardized

Fully standardizing one L2 to the exclusion of allowing others would solve the multi-vendor issue for point-to-point links. But, standardizing one exclusive L2 protocol that must be used in the UTRAN NEs would restrict the flexibility for the operators. A solution which solves the multi-vendor issue, but still offers the full flexibility would be the preferred approach for the L2 standardization for IP transport in UTRAN.

Requiring the implementation of one or a limited set of L2 protocols, but still allow the use of any L2 protocol in the UTRAN NEs would be a good solution for the standard.

The L2 protocol specified in the standard to be implemented in the UTRAN NEs should be the PPP protocol [11] with its extensions PPPmux [10] and ML/MC-PPP [20], [21] and header compression. During the work in RAN3 for IP transport it has been shown that the PPPmux approach fulfils the requirements and provides good performance.

The layer 2 framing protocol below PPP is FFS.

## 6.7 Radio Network Signalling bearer

This study area is related to the transport of Radio Network Signalling over an IP network.

### 6.7.1 Iub RNL signalling bearer

#### 6.7.1.1 SCTP characteristics

SCTP/IP [24], [25] can provide the following:

- acknowledged error-free non-duplicated transfer of user data;
- data fragmentation to conform to discovered path MTU size;
- sequenced delivery of user messages within multiple streams, with an option for order-of-arrival delivery of individual user messages;
- optional bundling of multiple user messages into a single SCTP packet;
- network-level fault tolerance through supporting of multi-homing at either or both ends of an association;
- congestion avoidance behaviour;
- resistance to flooding and masquerade attacks.

#### 6.7.1.2 Proposal 1

In an IP network, transport protocols like TCP or UDP are used to transport messages. UDP is unreliable. TCP has weaknesses regarding signalling transport e.g. it is a byte-oriented protocol instead of a message-oriented protocol (see [24], [25]). SCTP, the new protocol that is being developed in IETF for the purpose of signalling transport in an IP network, is a suitable alternative. Furthermore, SCTP has already been introduced on Iur and Iu-PS interfaces in Release 99 / Release 4 specifications. (See [4] and [6]) Therefore, it is proposed to adopt SCTP on Iub as well.

The proposed protocol stack in RNC and Node-B for the IP option is as follows:

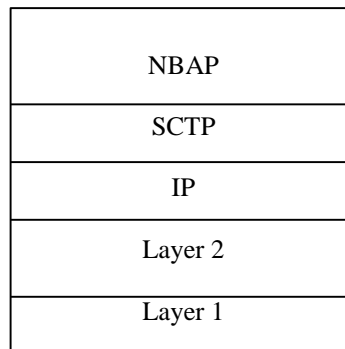

**Figure 6-17: Iub Signalling bearer protocol stack without Adaptation Layer**

### 6.7.1.3 Proposal 2

For an Sctp-based solution for the Iub signalling bearer, an Sctp adaptation module would be used between NBAP and the Sctp protocol.

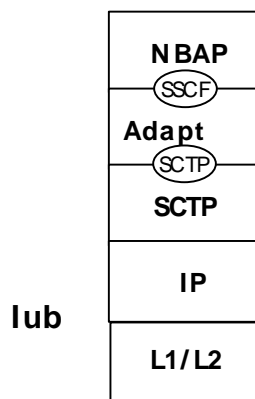

**Figure 6-18: Iub Signalling bearer protocol stack with Adaptation Layer**

### 6.7.1.4 Use of Sctp

A Sctp connection between two endpoints is called an association. One Sctp association can be considered as a logical aggregation of streams. A stream is a unidirectional logical channel between 2 endpoints. In order to achieve bi-directional communications, two streams are necessary, one in each direction. Each user message (i.e. a message originated from the Sctp user application) handled by Sctp has to specify the stream it is attached to, a stream identifier allows to identify each stream inside the association. Therefore, each Sctp stream can be considered as an independent flow of user messages from one Sctp node to another. The stream independence has the advantage of avoiding blocking between streams.

Between CRNC and Node B, one or several Sctp associations might exist. Node-B selects a Sctp association at creation of an UE context. It would not be very efficient to consider each association as a signalling bearer because all requirements of NBAP signalling transport can be fulfilled by one Sctp stream. Since it can be considered one Sctp association is an aggregation of NBAP signalling bearers, it is proposed that each NBAP signalling bearer be mapped on a pair of Sctp streams (one in downlink and one in uplink). The choice of stream identifiers being done by the user application, the simplest solution is to choose the same stream identifier for the two streams. Although two streams per association (one in each direction) is enough for the transfer of NBAP messages, this proposition adds more flexibility as it allows each association to support several flows of NBAP messages and it has the advantage to avoid blocking between signalling bearers.

[7] describes the Node-B logical model as it is seen from the CRNC. It defines one Node B Control Port and Communication Control Ports within each Node-B. A communication control port corresponds to one signalling bearer and each signalling bearer between Node-B and CRNC can at most correspond to one communication control port. At creation of an UE context, Node-B selects a communication control port whose identity is communicated to CRNC. According to the previous discussion, each communication control port will correspond to one SCTP association and two SCTP streams in opposite directions of the same association. And similarly for the Node-B control port.

It is expected NBAP specifications will not be impacted by this change. The IE "Communication Control Port Id" still identifies the signalling bearer i.e. one SCTP stream number inside one SCTP association between the Node-B and the controlling RNC.

## 6.7.2 RNSAP Signalling

The SUA [26], [50] delivery mechanism provides the following functionality:

- support for transfer of SS7 SCCP-User Part messages (e.g., RNSAP);
- support for SCCP connectionless service;
- support for SCCP connection oriented service;
- support for the seamless operation of SCCP-User protocol peers;
- support for the management of SCTP transport associations between a SG and one or more IP-based signalling nodes);
- support for distributed IP-based signalling nodes;
- support for the asynchronous reporting of status changes to management.

Given these capabilities, SCCP (and the associated adaptation protocol, M3UA) may be unnecessary and it should be considered that they may be eliminated in order to provide a simpler and more efficient signalling transport that may be carried via SUA/SCTP/IP over ATM AAL5 or other Layer 2 protocols, such as HDLC-PPP, etc.

## 6.7.3 RANAP Signalling

In order to minimize the changes on UTRAN Radio Network Layer and thus to reduce the number of different variants of any application signalling protocol, the SCTP shall be used together with the suitable Adaptation Module. This is according to the signalling transport framework architecture of the SigTran Working Group of IETF, RFC 2719 [24].

The following figure illustrates the application of Adaptation Module in the Transport Network Layer of Iu interface.

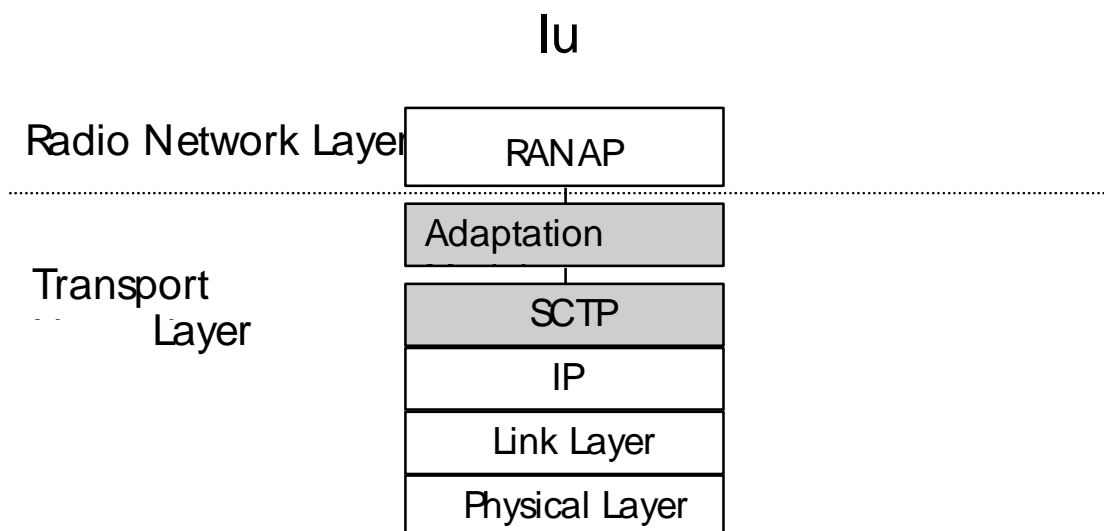

Figure 6-19: RNL Signalling bearers on Iu interface, the principle

## 6.7.4 PCAP signalling

The Iupc signalling transport protocol stack is structured the same as the Iur and Iu interfaces control plane, i.e. they are SCCP users. Therefore, the transport solution chosen for the Iur and Iu signalling interface shall also be applied to the Iupc interface.

## 6.7.5 SCCP/M3UA versus SUA

Based on contributions R3-012155 and R3-012163, this clause captures an analysis study effort done during the IP Adhoc #4 that attempted to do a comparison in the major areas between choices of SCCP/M3UA vs SUA as RNL Signalling Bearer options for RANAP and RNSAP.

The analysis was captured using a spreadsheet table format with 3 columns identified of:

- "Area" – technical aspect serving as basis for the comparison;
- "Advantage (SUA, M3UA, neither)" – indication if either SUA or M3UA or neither had any advantage over the other technology;
- "Weighting (0 – no advantage, 1 – low, 2 – medium, 3 – high most affecting)" – relative weighting of the indicated advantage.

The areas in **bold** were items that were treated during the analysis effort which were also areas that were covered in contributions presented at the IP Adhoc #4 session. It was also argued that this list of areas was incomplete. Consensus was not achieved.

The areas in *italics* were items that were suggested and agreed as important areas to be considered but were acknowledged not to be covered as they were not in the contributions presented at IP Adhoc #4 session.

Area	Advantage (SUA, M3UA, neither)	Weighting (1 – low, 2 – medium, 3 – high most affecting)
Routing Efficiency	SUA – one step mapping (as opposed to two step for M3UA,national boundary)	2
Addressing Flexibility	SUA - SUA does not mandate use of point codes	3
Standardization Maturity	Neither – M3UA has gone thru last call but requested to go thru last call again and SUA in last call to end 8/24/01	0
Protocol Complexity	SUA – M3UA has other obligations in its support that SUA not needed	2
Management Complexity	SUA – If M3UA is already there, management is more complex, in all other cases simpler (e.g. DNS, ENUM server address management & not needed management of SCCP and M3UA layer) with SUA.	1
Interworking	Neither – Requirement of sigtran on M3UA and SUA is to interwork with SS7 cleanly. M3UA – SUA alone not backward compatible with M3UA. It leads to additional SG and increased network complexity however SCCP/M3UA and SUA are peers thru use of SG, as defined in IETF SUA draft.	0
Backward Compatibility	M3UA – Neither candidate is RFC (preventing any multi-vendor implementation from existing) M3UA has done interoperability testing and issues found in earlier version, SUA has not done interoperability testing.	3
Testing Maturity		1

Weighted Total (SUA = 8, M3UA = 4)

*Areas not covered in either contribution on RNL Signalling Transport*

*Operational Cost*

*Iub Applicability*

*Scalability*

## 6.7.6 Interworking of SCCP/M3UA and SUA

In this clause the interworking principles within SS7 and SigTran networks are first shortly explained and then the more detailed description of the interworking between SUA and SCCP/M3UA is given.

### 6.7.6.1 Interworking in native SS7 networks

In SS7 both MTP-3 and SCCP have several national variants (ETSI, ANSI, China, etc.) that are incompatible with each other. In addition to national variants there is the international version of both protocols (ITU-T) to enable worldwide

connectivity between national SS7 networks. As a conclusion, in SS7 networks whenever there is a need for connectivity between different countries or between different operators' networks, the application of a Signalling Gateway is a necessity. This applies both for MTP-3 and for SCCP. Here the Signalling Gateway is a Signalling Point that has an interface to all SS7 networks that are to be connected through it.



Figure 6-20: Global SS7 networking

The use of SCCP on top of M3UA makes the availability of a Signalling Gateway a must also in SCCP/M3UA networks. Only in SUA-only environment there is no need for interworking within the signalling network itself. This is for the reason that neither MTP-3 nor SCCP are present there.

### 6.7.6.2 Interworking in SS7 and SigTran Networks

In SS7 networks the nodes involved in signalling/signalling transport are called Signalling Points (SP). A Signalling Point can be either a Signalling End Point (SEP) or a Signalling Transfer Point (STP). The Transport Network Layer of the SS7 network is called Network Service Part (NSP). In the following figure there are the TNL of the traditional SS7, of UTRAN Rel99&Rel4 IP option and of the proposed SUA based Rel5 IP option.

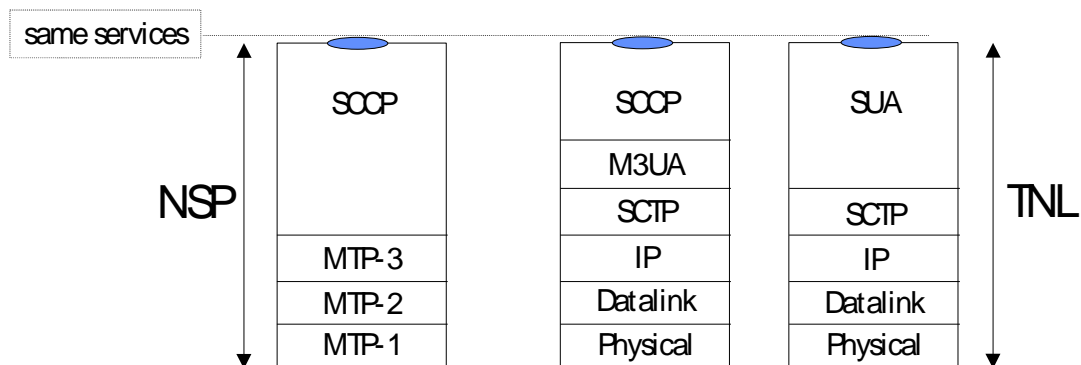
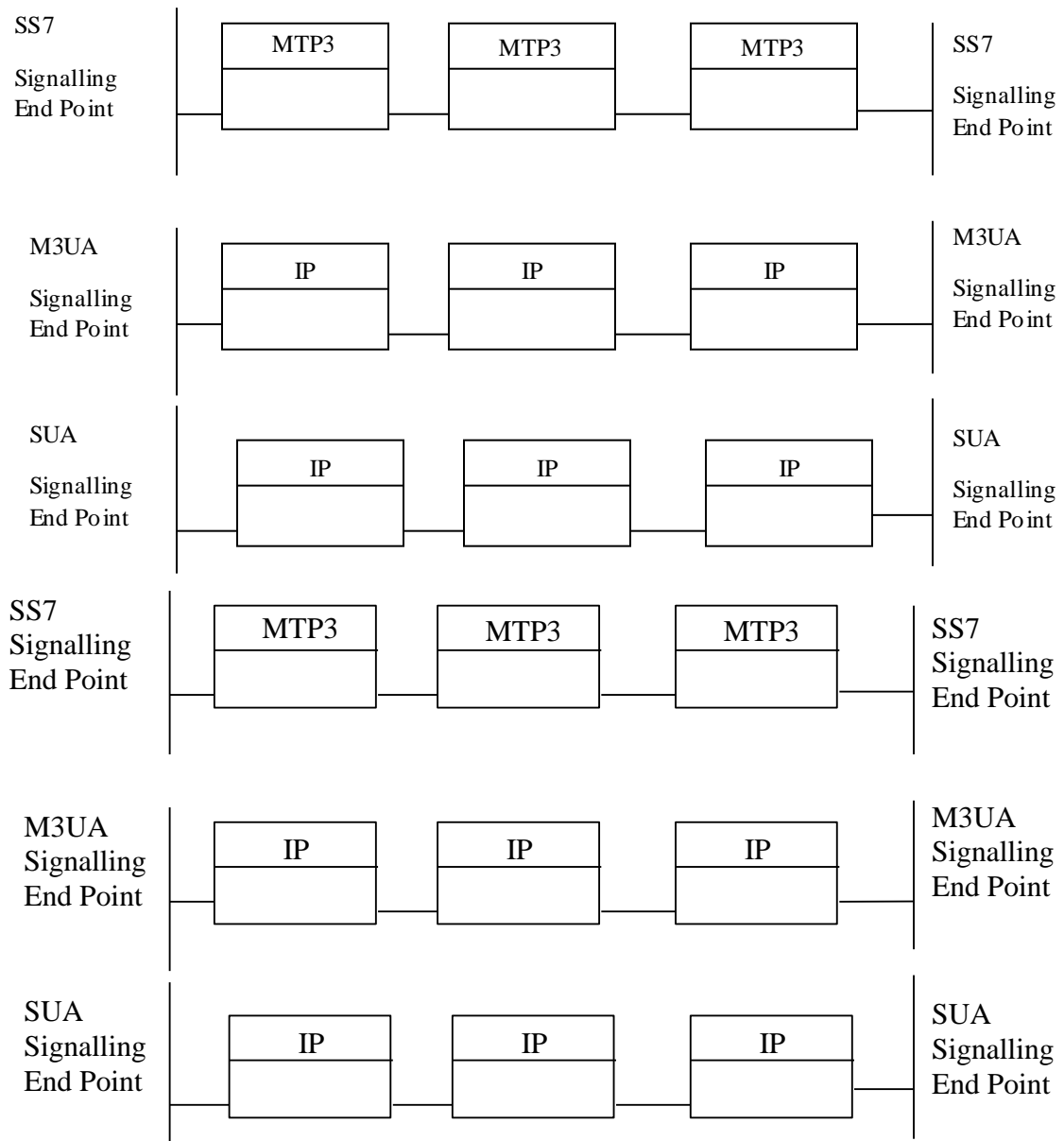

Figure 6-21: Network Service Part/Transport Network Layer protocols

A couple of remarks related to the figure above: In SS7 networks it is the responsibility of a Signalling Transfer Point (STP) to act as a router while the routing is based on MTP-3 (link-by-link) and SCCP (end-to-end). In case of SigTran the networking is provided by Internet Protocol. It is the role of an ordinary IP router to route the signalling message from the originating Signalling End Point to the destination Signalling End Point. The following figures further illustrates the protocols used in the signalling network between the Signalling End Points. The peer application protocols are only in the Signalling End Points.



**Figure 6-22: Signalling networking in case of SS7 (top), SCCP/M3UA (middle) and SUA in single operator environment (APPLICABLE TO UTRAN)**

In figure 6-22 above there is the single operator environment depicted. UTRAN in general is a single operator environment. That is, it is assumed that each Signalling End Point knows the routable address to all other Signalling End Points. Furthermore, in case of SS7 and SCCP/M3UA it is also assumed that each Signalling End Point knows the non-routable Signalling Point Codes of all other Signalling Points present in the network. For this reason there is no need for Global Title Translation from a routable address to the Signalling Point Code. In any larger network (in terms of number of Signalling Points) this approach results in large Signalling Point Code tables in each and every Signalling End Point, with the resulting operation & management work.

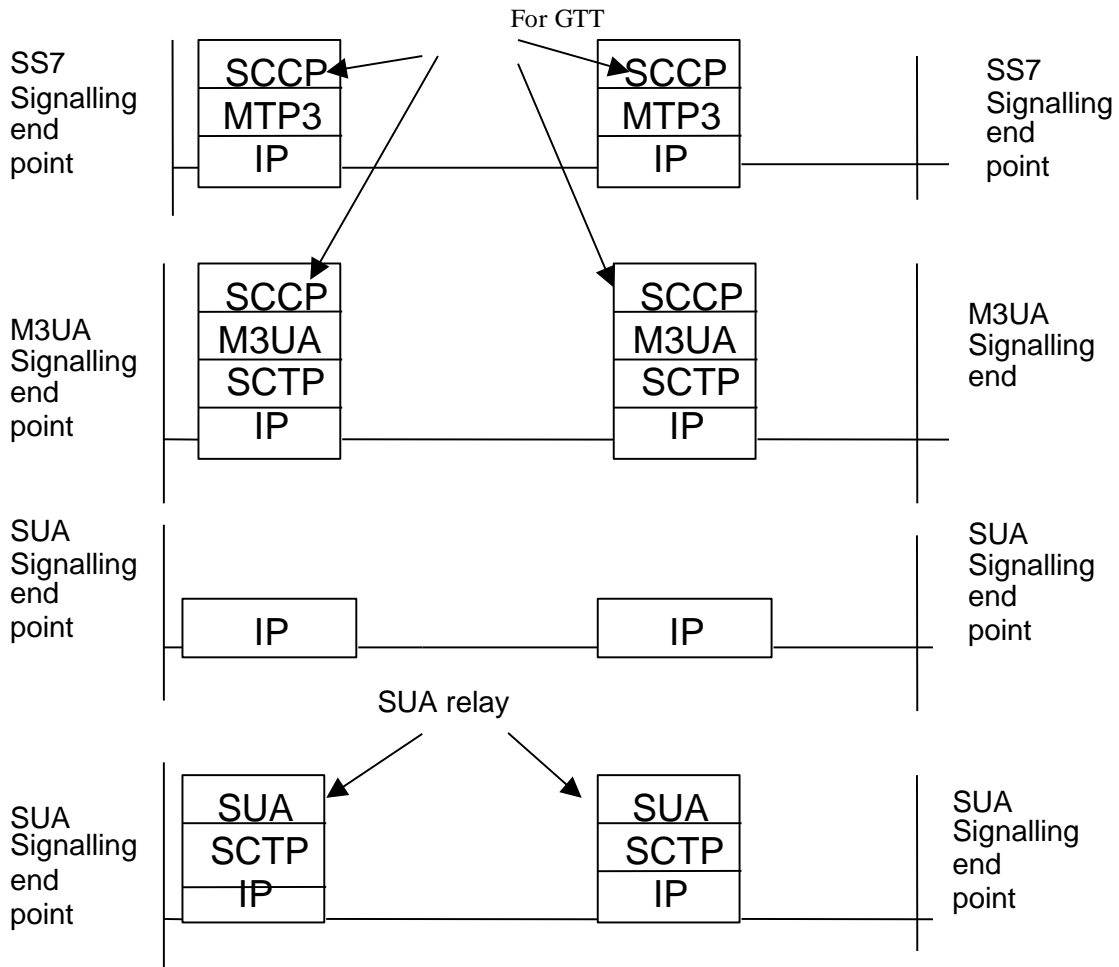

**Figure 6-23: Signalling networking in case of SS7 (top), SCCP/M3UA (middle) and SUA in multi-PLMN environment (NOT APPLICABLE TO UTRAN)**

In figure 6-23 above it has been assumed that the signalling networking extends over PLMN boundaries. In such a scenario it cannot be assumed that each Signalling End Point would know the Signalling Point Code of its peer. This is for many reasons, like the following: Signalling Point Codes may not be unique in two different PLMNs, the size of the Signalling Point Code tables in the involved Signalling End Points would become too big in size, operators do not want to allow direct visibility of their SPs over PLMN boundaries, etc. For this reason the Global Title Translation function is needed in the networks. For SUA there are two cases included. In the first case each Signalling End Point knows the routable address (logical name, IP address) of its peer. In the second case SUA relay is used. The SUA relay has been defined in clause 1.4.6 of SUA [26]. SUA relay function allows the determination of the next hop SCTP association towards the destination Signalling End Point. This determination may be based e.g., on Global Title information (E.164 number) in analogy with SCCP GTT in SS7 and M3UA networks above. However, the difference is that in SUA there is no Signalling Point Codes but the relay function operates with routable addresses. The SUA relay was introduced in SUA protocol to allow greater scalability, flexibility and reliability in wide-scale deployment of SUA (note: In M3UA there is no relay function specified).

Figure 6-24 depicts the two ways that SCTP associations can be established among IP based signalling nodes, the top one shows the mesh network with SCTP associations established between each other. The bottom one shows SCTP associations between two signalling end nodes are bridged through SUA Relay nodes.



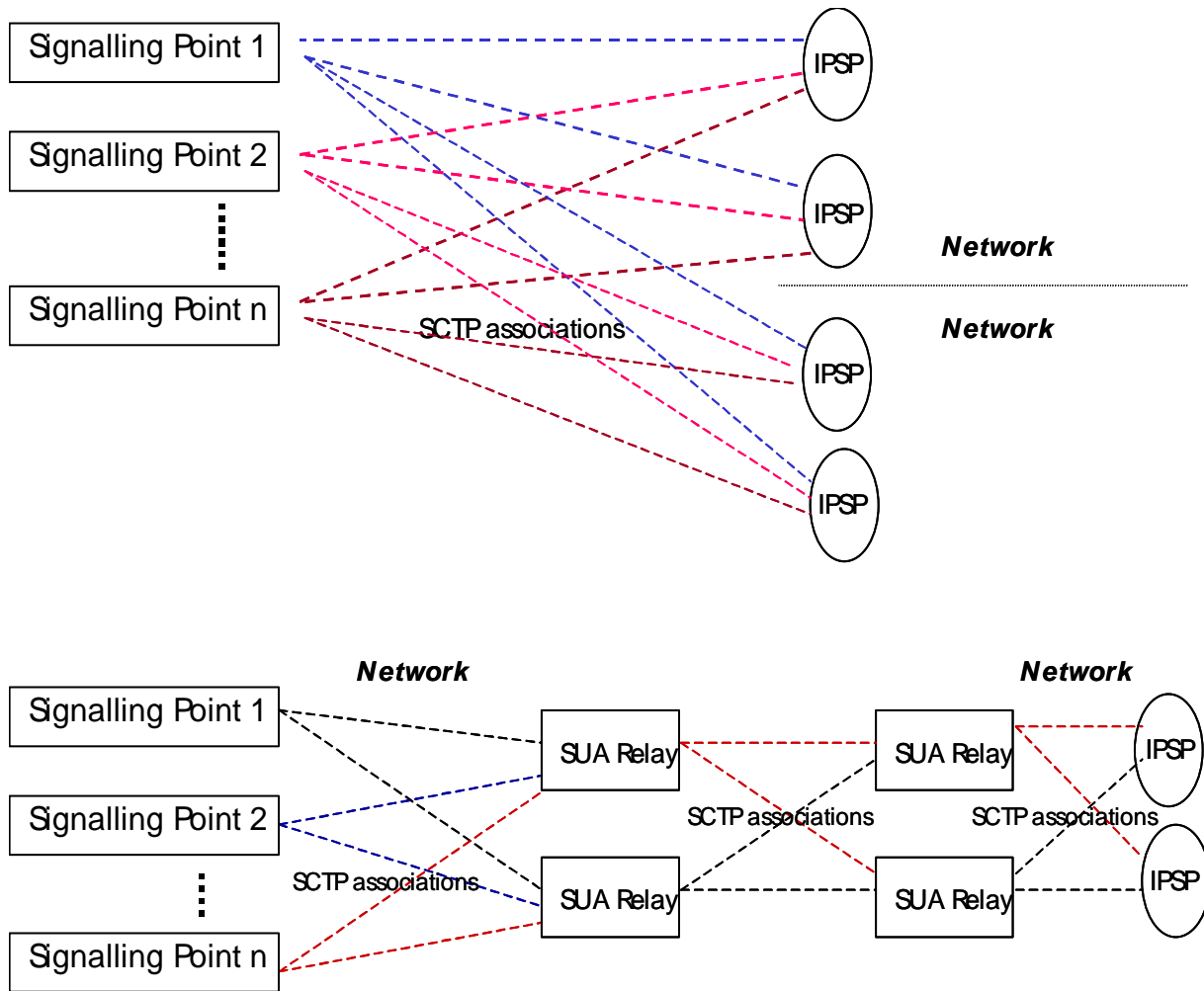

Figure 6-24: Interconnecting Operator Networks with SUA

The networking aspect described above is important also because of the following consideration. In the discussions in RAN WG3 the concern has been raised that as there is the Bearer Independent Call Control protocol (BICC) used in the UMTS Core Network and as it is an MTP-3 User, inherently incapable of using SCCP or SUA, its presence together with SUA would create an interworking issue. However, the description above showed this concern to be invalid. The interworking is only needed for the peer SCCP User protocols. If there are two BICC peers communicating with each other, then they share the signalling network (i.e., IP network) with SUA Users between their corresponding Signalling End Points. In the Signalling End Points the signalling stacks are e.g., as follows:

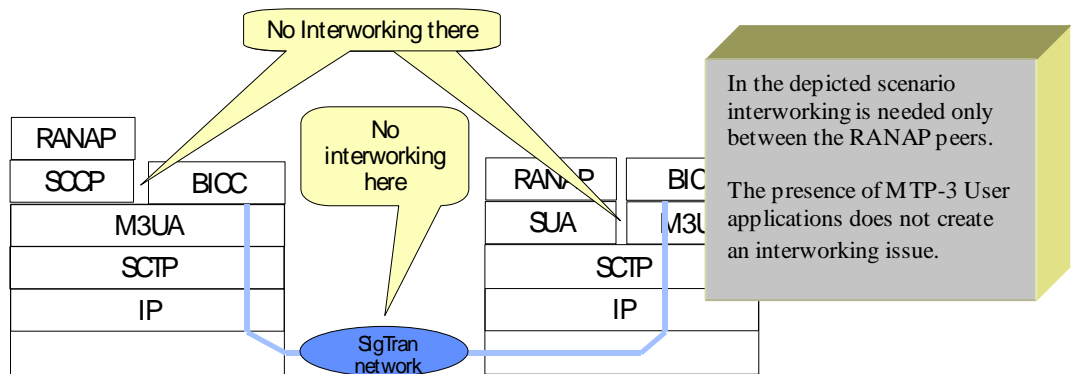

Figure 6-25: MTP-3 User (BICC) and SCCP User (RANAP) in the same network

As it is shown in the figure, there are now two Signalling Users present, one is a genuine SCCP User (RANAP) while the other is an MTP-3 User (BICC). In the node on the right there are two SCTP Users, one is SUA and the other is M3UA. The same SCTP instance is used to serve both of its users there. In the node on the left the stack is different;

there we have two M3UA Users, one is the BICC while the other is the SCCP. The same M3UA instance can serve both of its users. There is no interworking involved that would be caused by the presence of both MTP-3 Users (BICC) using M3UA and SCCP Users (RANAP) using SUA.

### 6.7.6.3 Interworking in UTRAN

Regardless of the used SigTran adaptation layer there is a need for interworking between the non-IP SS7 network interfaces and SigTran network interfaces. The Signalling Gateway needs to offer the protocols and their interworking as shown in figure 6-26.

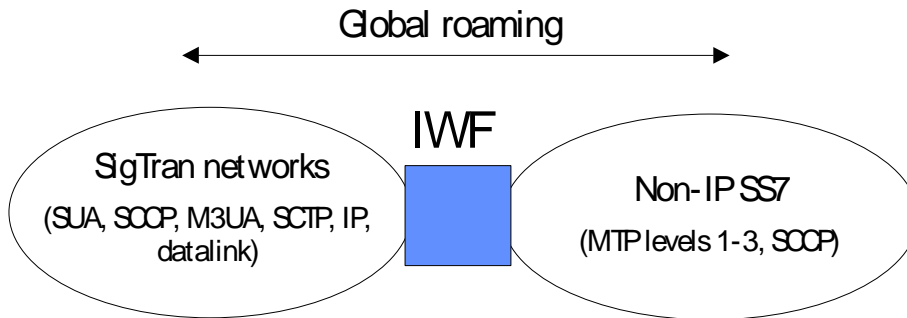

Figure 6-26: Interworking between SigTran and non-IP SS7

Interworking within the SigTran domain is necessary if one of the Application protocol peers (e.g., RANAP-RANAP) is using SCCP/M3UA-based SigTran stack while the other is using SUA-based stack. As it was described earlier, there is still no need for interworking in the signalling transport network as such, because of the fact that the signalling transport within the intermediate transport network is carried out by IP protocol and IP routers in both cases. The SCTP and its adaptation layer are implemented only in the Signalling End Point where the Application protocol peers are implemented. The only reason for any interworking in the network would result from the use of more than one SCCP variant in the SCCP/M3UA side of the SigTran domain. In this case the interworking would be purely between the two variants of SCCP.

In the following figure some of the SUA-SCCP interworking options are illustrated.

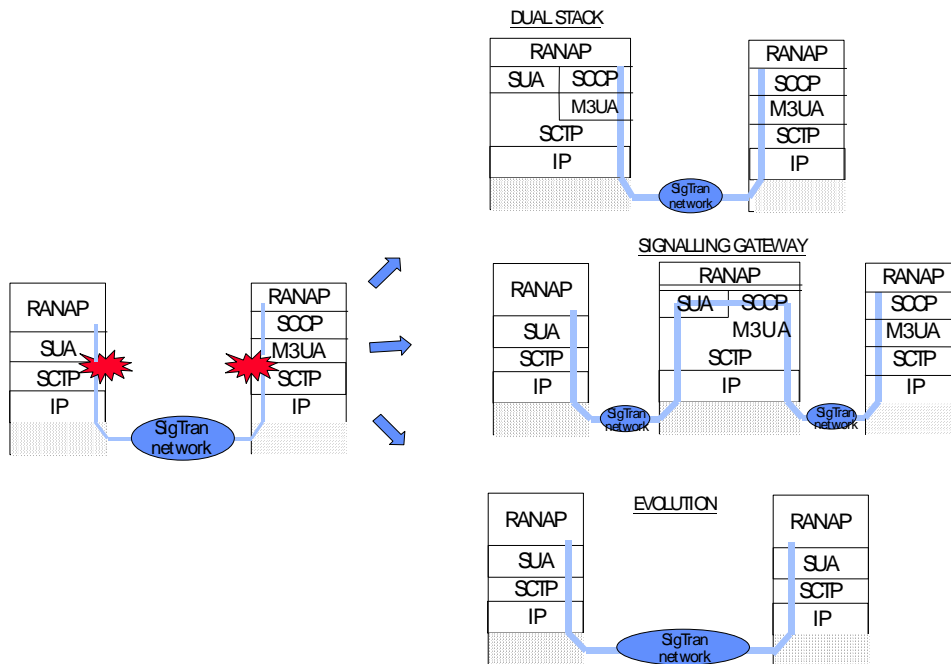

Figure 6-27: Interworking between the SCCP User peers in UTRAN

As a conclusion for now it is said that the Signalling Interworking Function as such is needed in the 3GPP networks regardless of the application of SUA. This is the case in order to provide global roaming in SS7 environment in general, due to national variants of both MTP-3 and SCCP, and in order to connect non-IP and IP (SigTran) network interfaces

together. SUA introduces a need for interworking between the peer SCCP User application protocols in case the other end point is using SCCP/M3UA bearer. However, the intermediate signalling network does not need to be affected by this interworking.

#### 6.7.6.4 SCCP and SUA interworking in detail

SUA is designed to interwork with SCCP seamlessly at a Signalling Gateway. SUA has a class of messages for informing the SS7 network of the availability of the nodes in the IP network, and a class of messages for informing the IP network of the availability of nodes within the SS7 network. For applications running over SCCP or SUA, there is no impact on the interworking of SCCP and SUA at the Signalling Gateway.

Below there are examples of interworking between applications running in the IP domain and applications running in the SS7 domain. The Sigtran Working Group recommends that more than one Application Server Process (ASP) be made available as a Signalling End Point (SEP) within the IP network. RANAP/RNSAP would be terminated at the ASP in the IP network.

As far as the mapping of the signalling messages is concerned, the following examples cover only SCCP and SUA protocols. This for the following reasons:

- 1) Interface but the interworking is between SCCP and SUA.
- 2) The Signalling Gateway represents the availability of the Application Server Process in SUA domain to the Signalling End Point in SS7 domain (and vice versa).
- 3) In the SUA side it is the responsibility of the SUA to manage the availability of the Application Server (made up of one or several ASPs handling the SCCP User messages in question) while it is the responsibility of the SCTP to keep the association available between a particular ASP and the SG (e.g., keep-alive, multi-homing). For the case where an association or an ASP goes down, the SUA has the procedures available for the fail-over. On the other side of the SG, SCCP, M3UA and SCTP protocols perform similar functions. It is only the SCCP level actions that are visible on the other side of the SG, while the roles and relationship of the underlying MTP-3 level functions (link management, traffic management and route management) and the SCCP level functions are according to the SS7 specifications.
- 4) The key point is that the SEP and SG(s) as well as the SG(s) and ASP(s) are made concerned about each other's availability and that they have been configured as redundant (link, route, association, ASP, etc.). As a result each entity is able to determine if the peer is still reachable and if a fail-over to a backup is needed and how to reach the backup.

##### 6.7.6.4.1 Establishment of SUA connectivity

Each involved node is configured with the connections that need to be setup.

```

ASP 1          ASP 2          SG          SEP
(Primary)      (Backup)
|-----Establish SCTP Association-----|
|-----Estab. SCTP Assoc-----|
|-----Align SS7 link-----|

```

Each IP SEP declares to the SG that it is running.

```

+-----ASP Up----->
<-----ASP Up Ack-----+
+-----ASP Up----->
<-----ASP Up Ack-----+

```

The Primary IP SEP declares to the SG that it is active. The SG notifies all IP SEPs.

```

+-----ASP Active----->
<-----ASP Active Ack-----+
<-----NTFY (ASP Active)-----+
<-----NTFY (ASP Active)-----+

```

The SG represents the availability of ASP 1 to the SEP.

```

+-----SSA----->

```

SubSystem  
Allowed

The SEP declares its availability to the SG. Similarly, the SG informs the active ASP of the availability of the SEP as dictated by SGs concerned list. N.B. The SG maps the SS7 address of the SEP to an IP address, which the SG knows ASP 1 will understand.

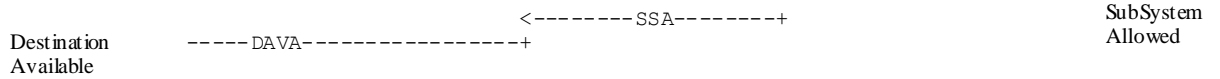

Traffic can now flow. A connectionless flow is shown for simplicity. Nevertheless, the SG is responsible for mapping IP to SS7 addresses and vice-versa. Only the Routing Context for ASP 1 persists from ASP 1 to SEP.

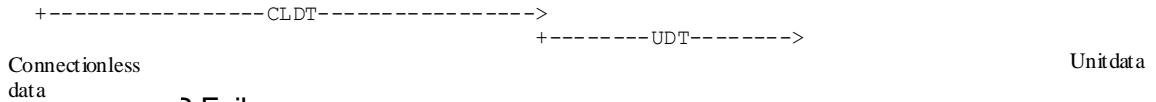

### 6.7.6.4.2 SEP Failover

The SEP knows that the SG is 'concerned' about its availability. Similarly, the SG knows that ASP 1 is concerned about the SEPs availability; therefore the incoming SSP is translated into DUNA. ASP 1 uses a DAUD to instruct the SG to invoke the SS7 Sub-system Test procedure.

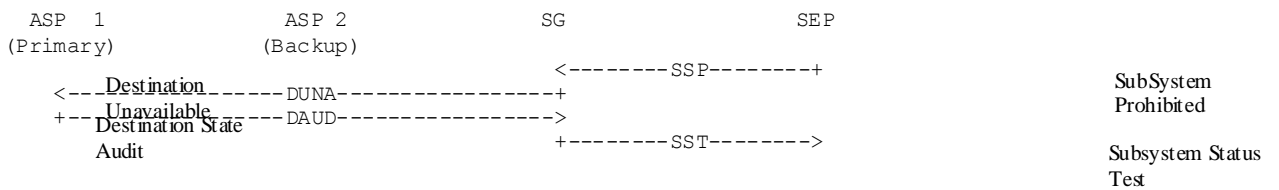

### 6.7.6.4.3 Successful ASP Failover scenario

The following is an example of a successful failover scenario, where there is a failover from ASP 1 to ASP 2, i.e. Primary to Backup. During the failover, the SG buffers any incoming data messages from the SEP, forwarding them when the Backup becomes available. Traffic can flow normally after the failure.

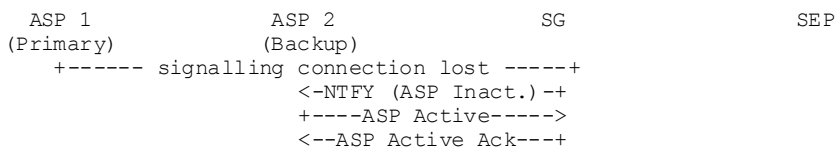

## 6.7.6.4.4 Message mapping between SCCP and SUA

For the seamless support of transfer of SCCP-User Part messages, SCCP messages are mapped into associated SUA messages according to the table below [50].

SUA NAME	SUA Full Name	SCCP NAME	SCCP Full Name	Classes				Mgt. Msg.	SUA Usage
				0	1	2	3		
Connectionless Messages									
CLDT	Connectionless Data Transfer	UDT	Unitdata	x	x	-	-	-	-
CLDT	"	XUDT	Extended unitdata	x	x	-	-	-	-
CLDT	"	LUDT	Long unitdata	x	x	-	-	-	-
CLDR	Connectionless Data Response	UDTS	Unitdata service	x	x	-	-	-	-
CLDR	"	XUDTS	Extended unitdata service	x	x	-	-	-	-
CLDR	"	LUOTS	Long unitdata service	x	x	-	-	-	-
Connection-Oriented Messages									
CODT	Connection Oriented Data Transfer	DT1	Data form 1	-	-	x	-	-	-
CODT	"	DT2	Data form 2	-	-	-	x	-	-
CODT	"	ED	Expedited data	-	-	-	x	-	-
CODA	Connection Oriented Data Acknowledge	AK	Data acknowledgement	-	-	-	x	-	-
CODA	"	EA	Expedited data acknowledge	-	-	-	x	-	-
CORE	Connection Request	CR	Connection request	-	-	x	x	-	-
COAK	Connection Acknowledge	CC	Connection confirm	-	-	x	x	-	-
COREF	Connection Refused	CREF	Connection refused	-	-	x	x	-	-
RELRE	Release Request	RLSD	Released	-	-	x	x	-	-
RELCO	Release Complete	RLC	Release complete	-	-	x	x	-	-
RESRE	Reset Request	RSR	Reset request	-	-	-	x	-	-
RESCO	Reset Confirm	RSC	Reset confirm	-	-	-	x	-	-
COIT	Connection Oriented Inactivity Test	IT	Integrity test	-	-	x	x	-	-
COERR	Connection Oriented Error	ERR	Protocol Data Unit Error	-	-	x	x	-	-
SS7 MGT Messages									
SCON	Network Congestion	SSC	Destination/subsystem-congested	-	-	-	-	x	-
DAVA	Destination Available	SSA	Destination/subsystem-allowed	-	-	-	-	x	-
DUNA	Destination Unavailable	SSP	Destination subsystem-prohibited	-	-	-	-	x	-
DAUD	Destination State Audit	SST	Destination/subsystem-status-test	-	-	-	-	x	-
n/a		SOR	Subsystem-ooos-req	-	-	-	-	x	-
n/a		SOG	Subsystem-ooos-grant	-	-	-	-	x	-
DRST	Destination Restricted	n/a	Destination Restricted	-	-	-	-	x	-
SUA MGT Messages									
ASPUP	ASP Up	n/a	n/a	-	-	-	-	-	x
ASPDN	ASP Down	n/a	n/a	-	-	-	-	-	x
ASPAC	ASP Acknowledge	n/a	n/a	-	-	-	-	-	x
ASPIA	ASP Inactive	n/a	n/a	-	-	-	-	-	x
NTFY	Notify	n/a	n/a	-	-	-	-	-	x
ERR	Error	n/a	n/a	-	-	-	-	-	x

SUA messages (CLDT, CLDR) support all 6 SCCP connectionless messages.

- = Message not applicable for this protocol class.

X = Message applicable for this protocol class.

N/a = not applicable

### 6.7.6.5 Conclusions

Based on this contribution the following is concluded.

- 1) Signalling Interworking Function is needed in 3GPP networks in order to provide global roaming and in order to interconnect non-IP and IP-signalling (SigTran) networks. This is irrespective of the type of SigTran adaptation layer.
- 2) Co-Existence of MTP-3 User application protocols (e.g., BICC) and SUA does not generate need for interworking.
- 3) Interworking of SUA and SCCP is needed to connect two application protocol peers (e.g., RANAP-RANAP), one using SCCP/M3UA and the other using SUA. M3UA and SUA as SigTran protocols have common network layer in the intermediate signalling network.
- 4) Interworking of SUA and SCCP is an integral part of the SUA specification. The Signalling Gateway functionality is a key feature of SUA protocol. In interworking the Signalling Gateway represents the SUA endpoint to SCCP/M3UA endpoint and vice versa.

## 6.7.7 Iub Signalling Bearer Comparison Data

### 6.7.7.1 Comparison TCP, UDP, SCTP

#### 6.7.7.1.1 User service

A first difference between these three protocols is the user friendliness of the format presented to the user application.

TCP is a byte-oriented protocol whereas SCTP is message oriented. This allows easier parsing of messages at the application layer because there is no need of establishing boundaries.

However, this advantage is quite negligible. Also in case this would be desired, a tiny adaptation layer can do the job over TCP.

#### 6.7.7.1.2 Reliability

UDP is well known to be an unreliable protocol due to its connectionless state.

To the opposite, TCP features SACK messages that allow a quick detection of loss of packets. TCP also implements a fast retransmit option that can be associated in order to send the SACK messages faster than normal packets when losses are detected.

The result of these mechanisms is that call set-up times are expected to be more evenly distributed together with being shorter whereas the simple detection of packet loss would take more than 500 ms with UDP.

SCTP features the same advantages as TCP compared to UDP because it is similarly a connection-oriented transport protocol.

#### 6.7.7.1.3 Availability

Congestion control performance is also less effective with UDP because congestion states are computed on a transaction per transaction basis, rather than across all transactions. To the opposite TCP and SCTP maintain congestion control over the entire connection so that the aggregate rate of messages can be controlled.

In terms of availability, one of the key new features brought by SCTP is the multi-homing: this means that a single SCTP endpoint can support multiple IP addresses. Multi-homing can be used for redundancy and allows a greater survivability in case of network failures. For example, it could be combined with the use of different prefixes to force the associated routing to go through different carriers.

Multi-homing is a clear differentiator on SCTP side but can be considered minor since it is today associated with fall back modes and cannot be used for load sharing.

6.7.7.1.4 Defence/Security

One of the key technical advantage of SCTP is the security aspect that is more developed. A "cookie" mechanism has been incorporated to guard against some types of denial of service attacks. In particular, it is efficient against a blind attacker trying to get memory and resources down of an SCTP server by overflowing it. It uses signature authentication without need of key exchanges with the client.

6.7.7.1.5 Performance

Another differentiator for SCTP is the efficiency of the use of the connections it makes. SCTP features the "multi-streaming".

According to the node-B logical model as defined in TS25.430, one signalling bearer per communication control port is set up which result in several TCP connections on one hand or one to several SCTP associations on the other hand between the node B and the CRNC.

In a likely NBAP scenario, one signalling bearer would be mapped either on one TCP connection on one hand or onto two SCTP streams of one SCTP association on the other hand. This is because one SCTP stream is unidirectional.

Therefore, they could be from one to several SCTP associations depending on the signalling endpoints.

The corresponding drawing shows the mapping of signalling bearers onto TCP streams:

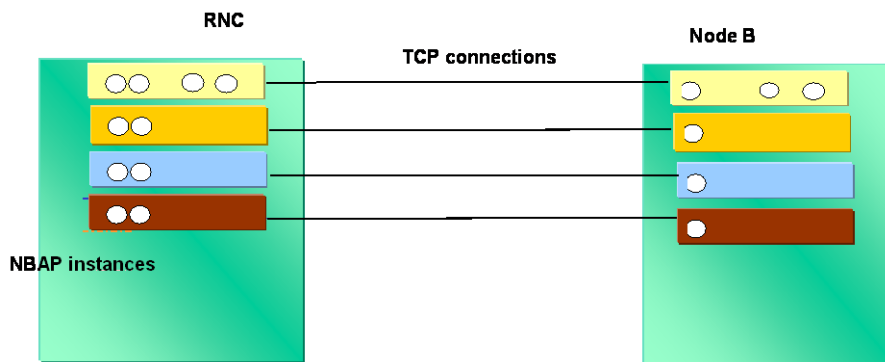

The corresponding drawing shows the mapping of signalling bearers onto SCTP streams:

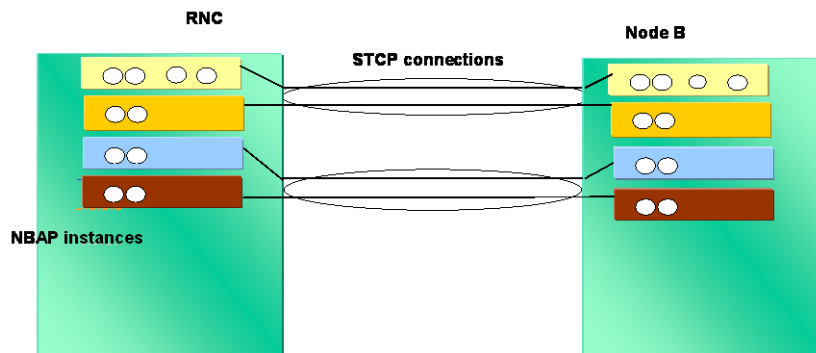

The main advantage of SCTP compared to TCP results from the mapping of the signalling bearers onto different streams which can be considered as independent flows of user messages.

The resulting benefit is to avoid the so-called head of line blocking between signalling bearers. To the opposite, when using TCP, several transactions can be multiplexed within a single TCP connection and the loss of one transaction can hamper concurrent ones.

However, this benefit only occurs under loss conditions and the Iub is not considered a lossy link. For example, even when microwave links are being used, it has already been shown (around UDP-lite discussions) that the loss rate is negligible 99,99% of time and that losses only occur during fading which result anyway in deconnection. The SCTP resilience to head of line blocking is therefore minor when considered on Iub.

Also, using one TCP connection per signalling bearer in the node B seems a reasonable possible implementation. When there are too many, anyway, SCTP has the same troubles than TCP since it agrees at the beginning on the number of streams opened and when all streams have been mapped, there is again the head of line blocking possibility. Management of SCTP streams is not that easy.

#### 6.7.7.1.6 RNL changes

In terms of addressing, each user message originated from the user application handled by SCTP has to specify the Stream Identifier within an SCTP association it is attached to. The choice of the stream identifiers is to be done by the user application. However, to that respect, all protocols should be equally footed.

#### 6.7.7.1.7 Implementation Difficulty

Compared to TCP, SCTP complexity is obviously greater as it can be compared as TCP plus additional features. Also the knowledge of the protocol is not the same. However, some of these features can be treated as options and need not be present at first time and therefore both can be considered equal regarding this criteria.

#### 6.7.7.1.8 Maturity

It is clear that TCP choice is more mature than SCTP. TCP has been existing for a long time in the market whereas SCTP is a new RFC from October 2000. However, the development of SCTP has taken into account several years of TCP existence. To this respect, the TCP experience has passed through SCTP and they can be equally ranked.

#### 6.7.7.1.9 Interoperability

Regarding interoperability, SCTP interoperability testing should have also already been conducted for the Iur/Iu and even if TCP is more mature regarding this interoperability, it features several variants that could thwart careless interoperability.

Finally, this gives a small advantage for SCTP.

#### 6.7.7.1.10 Operational aspects

SCTP already selected on Iur&Iu: but these interfaces affect the RNC. Today the choice of SCTP on the Iub would only result in the support of a new protocol in the node B. However, the choice of TCP would result in a new protocol in UTRAN. This gives an advantage for SCTP.



### 6.7.7.2 Summary

In order to summarize all the points made above, and to assign to them a proper weighting, even if the task is not always easy to be performed in an unbiased way, the following matrix tries to capture all these conclusions:

	UDP	SCTP	TCP
<b>User service</b>	1	1	0
<b>Reliability</b>	0	2	2
<b>Availability</b>	0	3	2
<b>Defence/Security</b>	0	2	0
<b>Performance</b>	0	3	1
<b>RNL changes</b>	0	0	0
<b>Implementation difficulty</b>	0	1	0
<b>Maturity</b>	0	0	0
<b>Interoperability</b>	0	1	0
<b>Operational aspect</b>	0	2	0

As a summary, this table shows that:

- UDP is too unreliable and too less performant compared to the others,
- even if both can address the requirements of the NBA P Iub signalling transport, SCTP offers actually both technical and operational advantages over TCP.

### 6.7.8 Reference Architecture for ENUM based Services

To transport SS7 applications (service/protocol) in an all IP environment, especially using peer-to-peer architecture, will require an infrastructure to translate the global titles and subscriber IDs (IMSI, IMEI, E.164) to an IP address of an SS7 service node.

Currently in an IP environment, there is no scheme defined for retrieval of service applications node address (IP address, Host name or URI etc.) based on IMSI as an identifier. The same can be applied to IMEI -International Mobile Equipment Identifier, which is used extensively as an identifier for mobile equipment to provide authentication/security services for the mobile subscribers.

The translation of these identifiers or so called Global Title (term used for identifiers in SS7 environment) to an IP address can be performed deploying an infrastructure based on ENUM/DNS servers or some other means. However, for ENUM/DNS to be used for mapping each identifier to IP address, we need to define a unique domain for each numbering plan (e.g. e164.arpa, e212.arpa and e214.arpa, IMEI.arpa, Point Code.arpa etc). Apart from creating new domains by the IANA, there is tremendous work that needs to be done to come up with procedures to administer these numbers. Not to mention the large memory requirement to accommodate the entire range of identifiers at each operator's domain to map the correct IP address to these numbers corresponding to the service application node(s).

A DNS server can be populated with IMSIs if an operator wishes to use IMSI and wants to establish his own private nation-wide data network. However, even though the present document does not preclude the use of IMSI/DNS, the problem still remains of managing two different DNS domains and not to mention other domains that might need to be added depending on the services associated with other global titles and subscriber IDs.

#### 6.7.8.1 Key requirements/assumptions of the mobility services using ENUM

IMSI (E.212) is used as the subscriber ID for roaming and registration services in mobile environment. The following are the key requirements to be supported by the ENUM based DNS infrastructure:

- Using IMSI received from a subscriber, identify a physical or a virtual node providing a specific mobility related service such as: MAP-HLR etc. within a PLMN.
- These service applications nodes and their IP addresses need to be under the control of the local domains. These should be defined by the service provider based on service providing capability, that is: a service application node's IP address can be provided in the local DB/ENUM depending on the type of services it is handling or the GT types/protocols it is capable of handling. This is further illustrated in later clauses of the present document.

- Using a common standards based infrastructure such as ENUM, identify the IP address of a specific service application node to be used for sending the subsequent MAP applications messages and to negotiate the GT data type to be used within the messages.
- To identify/discover the service handling capability of a PLMN. This can be further utilized for Service discovery prior to sending query associated with a specific service.
- A common solution based on ENUM, using both IMSI, E.164 and other global titles based numbering schemes to provide service/protocol discovery and service node identification (retrieval of the destination IP address) will simplify network management for the operators. The same common infrastructure for address resolution should be applied all SS7/IP user adaptation protocols. Derived requirements associated with this are:
  - Provide service discovery and identification of the appropriate service applications node for other services not associated with IMSI or E.164 numbers.
  - To provide ability of sharing a service application node across geographically dispersed PLMNs (centralized service concept).
  - Provide an inter-working between the various SS7/IP adaptation protocols.

### 6.7.8.2 Some definitions

Here, two new concepts are introduced: First: Service Application PLMN Code (SAPC) and, second: Addition of new services in ENUM under the control of the operators who have reached a roaming agreement for a set of subscribers.

**Service Application PLMN Code (SAPC):** Service Application PLMN Code (SAPC) is a unique E.164 number assigned to a PLMN providing a set of services. Table 1 gives examples of SAPC codes for different PLMNs. It should be noted that the use of wild card to denote an exchange code would work equally well and is covered by the SAPC concept introduced in this draft paper. However, the wild card use in DNS can cause unpredictable results. It is also recommended that it should not be used in DNS/ENUM. SAPC code assignment will undoubtedly work to associate a set of services uniquely with a PLMN.

SAPC concept applies to other services as well as potential future services such as Instant Messaging, Dispatch etc. which may not be based on or associated with E.164 numbering scheme. Refer to table 1 for SAPC codes and the associated services provided by a PLMN. Services can be associated with a number of different subscriber ID scheme, such as: E.164 (CAP, MAP, SIP), E.212 (MAP), E.XXX (Dispatch/group calls), Point Codes (SS7 support service) etc.

**Table 1: SAPC Example using an unique code (assigned to PLMN)**

PLMN	SAPC	Available Service URIs				
		SIP	MAP	CAP	DISPATCH	Protocol-URI
1	1-817-822-1999		X	X		X (SS7-SG)
2	1-817-707-2001		X		X	X (M2UA)
3	1-214-797-2001	X	X	X		X (M3UA)
4	1-212-363-1988		X		X	X (IUA)
5	1-212-676-1111		X	X	X	X (SUA)
6	1-516-676-0000	X	X	X		X (SUA)
7	1-202-765-0000		X		X	X (SS7-SG)
N	1-202-676-000	X	X			X (SUA)

**Services/Service application node:** Services could be based on and associated with any numbering scheme. Services could be in support of Voice Dispatch, Instant Messaging etc, and can be based on any identifier (E.212, E.214, E.164, IMEI, point code as node address etc.) using any protocol type. An example of a service can be support of the SS7 message routing functionality to legacy networks. Additionally, service can be associated with a particular protocol such as SUA @ IP add/host name, M3UA @ IP add/host name, XUA @ IP add/host name etc.

Discovery/Retrieval of IP address for a service application node can be based on any service URI specified in ENUM. New services can be standardized and introduced via ENUM in conformance with governing regulations.

**SCCP User Adaptation protocol (SUA):** SUA stands for SCCP User Adaptation protocol. SUA messages contain the global titles within the message body as part of the called party address field.

Here the use SUA is synonymous with XUA (any SS7/IP adaptation protocol such as SUA, M3UA, M2UA, M2PA, IUA etc.) to explain the reference architecture and operation for mobility services. SUA is used from here on as an example only.

### 6.7.8.3 System solution based on ENUM

The present document focuses on a solution that will work with just one domain (e164.arpa) in ENUM for all the numberings schemes which includes, E.164, E.212, E.214 etc., thereby reducing the memory requirements, administrative overhead, operational and management costs etc. The present document describes an architecture illustrating how SUA can deliver SCCP-User messages to the destination node using the Global Title Information that are based on IMSI as well as E.164 numbers. The architecture makes use of the RFC 2916 (ENUM/DNS) to achieve this by using the concept of Service Applications Code (SAPC) and the inclusion of mobility services URI (MAP URI etc.) in ENUM.

It is expected that operators populate the ENUM with MAP URI associated with mobility services such as MSC/HLR/VLR etc. End point service node IP addresses, associated with a set of services, need to be stored in ENUM corresponding to the SAPC belonging to the local operator for a given PLMN. These end node IP addresses are sent as part of the ENUM/DNS response to the query based on this PLMN SAPC (E.164 number format).

Received URI/IP address from the ENUM is based on the standard query information based on the preference and order. Therefore, either the URI/IP address of the service node providing the mobility services can be retrieved uniquely or all the services populated (provided by the service provider) can be known by using the ENUM query based on PLMN 's E.164 number (SAPC).

### 6.7.8.4 Service discovery/IP address retrieval of end service nodes

As stated earlier, service applications nodes can be defined by the service provider in ENUM, that is: a service application node's IP address can be provided in the local DB/ENUM depending on the type of services it is handling or a specific protocol based services that it is capable of providing.

#### Operational scenarios:

Two scenarios are described.

- First scenario (Figure 1) illustrates the service discovery with point code as the global title. An example of such a service is 'SS7 support service' to provide inter-working function for the legacy SS7 networks using point codes based addressing scheme and SG as the service application node. To further illustrate this, a small satellite PLMN not capable of providing legacy SS7 network support via SG could utilize this service via its main PLMN 1 supporting such a service. Therefore, using the SAPC concept in ENUM domain, a satellite PLMN could identify the IP address of a specific service application node to be used for sending the subsequent SS7 applications messages to the legacy SS7 network via the main PLMN.- Second scenario (Figure 2) illustrates the discovery of a virtual IP address of a proxy node for load balancing in a distributed architecture using SS7/IP user Adaptation Proxy function (SAP) concept. Signalling Gateway (SG) is shown as two separate functions: SIF and SUA for clarity and to utilize the load sharing function of the SAP for the legacy SS7 network messages.**Notes/assumptions:**
- Service Applications Node (example- SUA) can be based on any SS7/IP adaptation layer protocol.
- Local ENUM can contain a virtual IP address or an IP address of a physical service application node providing mobility services (HLR in this case)
- Discovery/Retrieval of IP address for a service application node can be based on any service URI specified in ENUM.
- Service discovery can be based on standard DNS/ENUM query with order and preference.
- PLMN 1 and PLMN N have roaming agreement and are aware of the SAPC codes for each other's PLMN.

#### Scenario 1: SS7 support services example using point code (see figure 1)

- **Operational steps:**
  - SUA node in PLMN N receives IMSI (registration request) from MS.

- PLMN N determines that the subscriber belongs to a PLMN with legacy SS7 support only.
- SUA node looks-up corresponding SAPC (E.164 number = 1-817-822-1999) in local DB/ENUM.
- SUA node uses this as the unique E.164 (ISDN) number for the PLMN 1 in ENUM query message.
- SUA node sends an ENUM query message (1). This is routed over other ENUMs to the local ENUM of PLMN 1.
- Local ENUM/DB in PLMN 1 receives the message (1) and looks up the services/protocols (including SUA-SG node's IP address) corresponding to SAPC received in the ENUM query.
- Local ENUM responds with message (2) with all services/protocols associated with SAPC of PLMN 1.
- Message (2) is routed over the IP network to PLMN N.
- PLMN N sends the SUA message (3) to PLMN 1 using the retrieved IP address of the SUA-SG node.
- SUA-SG sends message (4) to SS7 network with destination PC.
- SS7 network routes the message (5) to the appropriate PLMN.

(3) SUA message sent to the SUASG node based on the destination IP address received

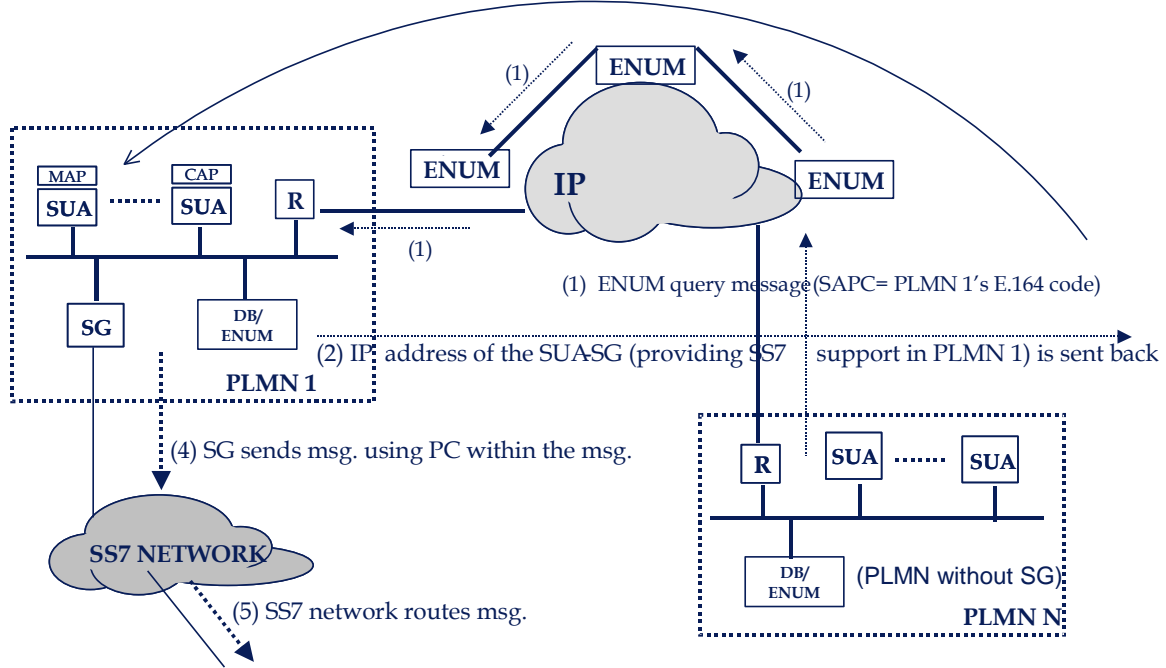

Figure 1: SS7 support services exampl (Point Code)

Scenario 2: SAP (virtual IP addree) operation for load balancing and distributed processing (see figure 2)

- Operational steps:

- SUA proxy (SAP) node in PLMN N receives IMSI (registration request) from MS.
- SAP node looks-up corresponding SAPC (E.164 number = 1-817-822-1999) in local DB/ENUM.
- SAP node uses this as the unique E.164 (ISDN) number for the PLMN 1 in ENUM query message.
- SAP node sends an ENUM query message (1). This is routed over other ENUMs to the local ENUM of PLMN 1.
- Local ENUM/DB in PLMN 1 receives the message (1) and looks up the services/protocol (including SAP node's virtual IP address) corresponding to SAPC received in the ENUM query.

- Local ENUM responds with message (2) with all services/protocols associated with SAPC of PLMN 1. Message (2) is routed over the IP network to PLMN N.
- PLMN N sends the SUA message (3) to PLMN 1 using the retrieved IP address of the SAP node.
- SUA Message (3) is routed over the IP network and received and terminated on SAP in PLMN 1.
- SAP examines the SUA message (3) content and discovers the routing criterion (SSN, GT data type, data translation type, etc.) and finds the service applications (SUA) node based on type of GT data (E.212, E.214, E.164, PC, IP address or a host name), service type and range by performing the query to the local DB (AMF function).
- SAP in PLMN 1 performs load balancing for the incoming SUA messages between multiple SUA nodes based on pre-defined criterion (e.g. based on registered ASPs serving m nodes) and sends the SUA messages and responses are directly sent to the same SUA node (AS-SUA) using the received IP address in the CLDT-SUA response message and the SCTP association.
- Incoming messages from the SS7 network are treated in the similar manner by SAP. See messages (5), (6) and (7).

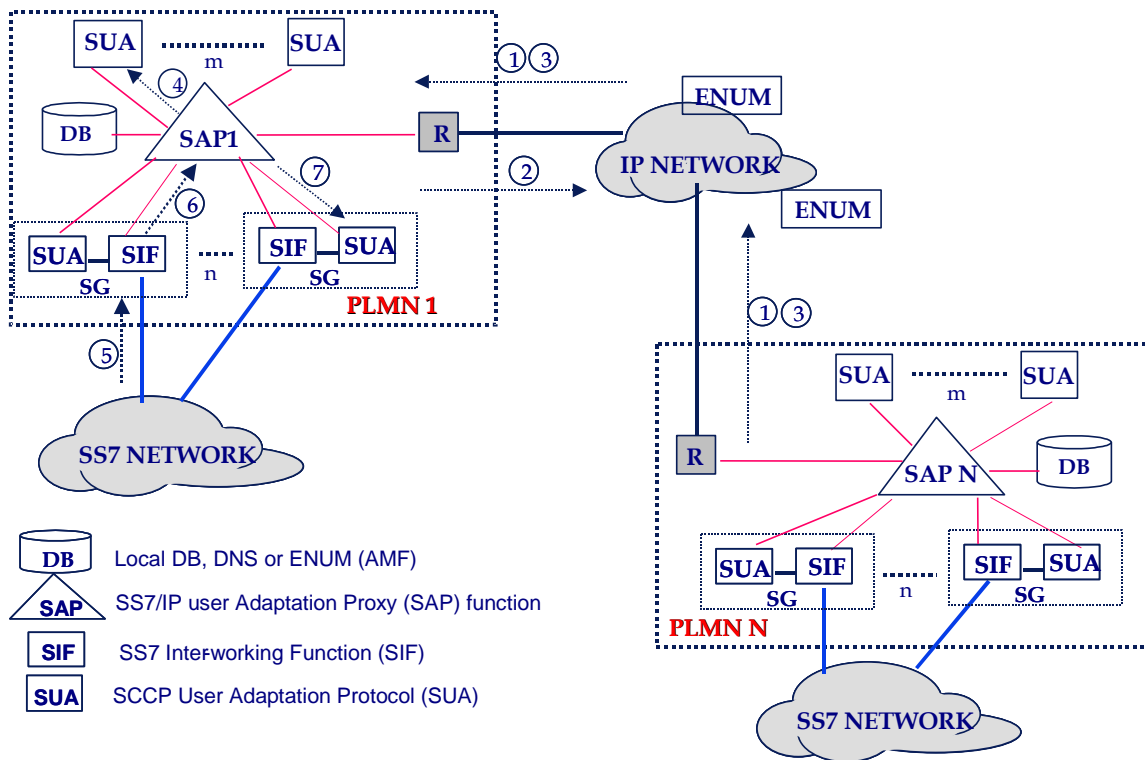

Figure 2: Distibuted SUA architecture with load balancing

## 6.8 Addressing

This study area is related to all addressing issues with regards to the introduction of IP Transport. For example, the advantages of using IPv6 should be investigated. Also, addressing issues relating to inter-working with AAL2/ATM nodes should be considered.

IPv6 has a 16 byte address field compared to 4 byte address field for IPv4. It is well known that the IPv4 public address space is running out, especially outside the U.S.

### 6.8.1 General addressing requirements

- IP addressing in UTRAN shall be logical and should not have any dependency on network element or interface type.

- In case of IPv4, to ensure efficient usage of IPv4 addresses and routing efficiency, IP based RAN shall adopt classless IP addressing scheme, using Variable Length Subnet Masks (VLSM).
- IP addressing in UTRAN scheme must support hierarchical routing network design and work well with the chosen routing protocol to provide best route convergence time in order to avoid network instability.
- Where applicable, IP addressing in UTRAN must budget for multi-homing of network elements.
- IP addressing in UTRAN must be scalable and take network element/interface growth and network expansion into consideration.
- RAN IP Addressing scheme must be flexible and be suitable for different RAN sizes and topologies.
- IP addressing in UTRAN must allocate addresses efficiently.

In an IP based UTRAN it is necessary that every UTRAN Node gets at least one IP address. Even in an UTRAN with ATM transport UTRAN Nodes will require IP addresses, e.g. for O&M functions. In fact there will be the situation that the most UTRAN nodes will have several IP addresses. Because of this reasons it is necessary to ensure that sufficient IP addresses are available. Especially when an operator decides to use public IP addresses for some UTRAN nodes, the availability of sufficient number of IP addresses must be studied with respect to the bearer addressing scheme.

If there is a private, isolated UTRAN network, then its possible that the IPv4 address space would be sufficient. However, if the UTRAN traffic is routed through a public network or a broader private network, then the IPv4 address space may not be sufficient. Using private addresses may require the use of a Network Address Translation (NAT) function when the UTRAN traffic must traverse a network using public addresses in order to translate public addresses to private when entering the private network. Private IPv4 addressing is a commonly used solution for extending the IPv4 address space.

However, the use of NATs causes problems in the network. Some of these are:

- It breaks the End-to-End Paradigm for Security when using IPSec.
- UTRAN protocols use external signalling to exchange transport address and connection identifier information. An Application Level Gateway might be needed to take care of ensuring that the correct addresses are used for a session. When intermediate Application Level Gateways are used the performance is hurt and the delay is increased.
- It adds costly manipulation on all packets.
- It is a single Point of Failure.
- It increases management and system configuration complexity.

## 6.8.2 Bearer addressing solutions

### 6.8.2.1 Destination IP addresses and destination UDP ports as connection identifiers

Destination IP addresses and destination UDP ports are used for connection identification based on the following assumptions:

- UDP ports provide approximately 65,000 connection identifiers. It is acceptable to require the addition of an IP address to support additional 65,000 connections. Adding IP addresses is not a concern, particularly if IPv6 is used in IP UTRAN networks.
- Using dynamic UDP ports means that a large range of UDP ports must be allowed through a fire wall for the radio network application IP host. This can compromise the internal network if the host also supports other applications that use dynamic UDP ports.
- The use of VPNs can be used to isolate the UDP ports used as connection identifiers from a firewall and can remove the need for a fire wall in some cases.
- Network Address Translators (NATs) can also cause problems when dynamic UDP ports are used since they change the address and possibly the UDP ports of packets. Only IPv6 could be used in the IP UTRAN network so

that NATs can be avoided or VPNs should be used such that NATs will not effect the IP address and UDP port used for the application.

## 6.9 IP transport and routing architecture aspects

### 6.9.1 Flexibility of IP architectures

Wide deployment and cost effectiveness of IP infrastructure are major reasons for introducing IP as a transport option in UTRAN. Therefore the chosen architecture must take best benefit of IP technologies and infrastructure.

Infrastructure transporting IP packets encompass a large variety of equipment like routers and switches, implementing a wide range of functions (routing, switching, route discovery, tunnelling, load sharing, QoS handling etc). The flexibility that can be used to combine those equipment and functions are a major advantage of IP.

It implies that several different architectures can be built with IP, which can adapt to various topologies and link layer technologies. This flexibility brings both adaptability and competitiveness.

That flexibility has to be considered, when defining higher layers for IP transport. No optimization should be made according to a limited set of topologies or link layer technologies that could later restrict the competitive advantage of IP.

### 6.9.2 Hosts and routers

Basically, the IP Transport Network is a set of nodes and links connecting Network Elements implementing UTRAN functions (Node B, RNC, and Management Platform). That network is responsible for transporting user, control plane, data and O&M data between the Network Elements implementing UTRAN functions with some requirements (addressing, security, Quality of Service...).

Several networks can fulfil these requirements. It relies on vendors, operators and third party service providers to determine best implementations for the transport network.

In an IP Transport Network, one can distinguish between end nodes (hosts) and intermediate nodes responsible for forwarding IP packets.

Since standardization of IP transport option is intended to be layer 2 independent, in this study area, IP Transport architecture is limited to nodes implementing an IP layer.

Nodes implementing an IP layer are either hosts, or routers. According to [8], the forwarding capability is the only feature distinguishing routers from hosts.

IP Hosting is a necessary function for a network element supporting of the UTRAN functions (Node B, RNC) but these network elements may also include transport network functions. Like AAL2 switching for ATM transport, IP forwarding and routing is not part of UTRAN functions. Routers connect networks of IP hosts to build internets. Hosts are not allowed to route packets they did not originate.

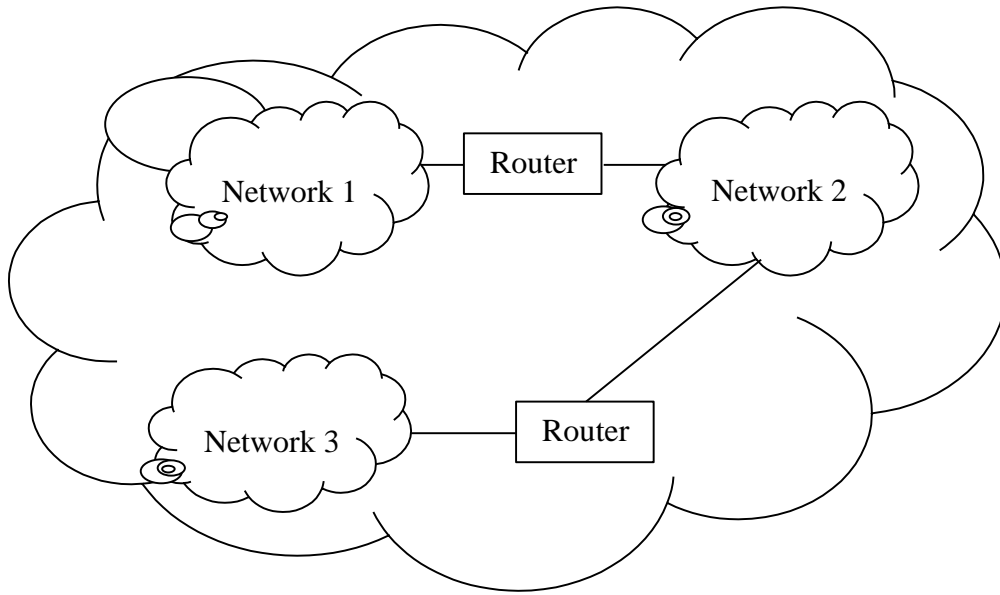

**Figure 6-28: Routers interconnecting IP networks**

Routers forwarding IP packets in the transport network may have the following characteristics:

- They can process user plane and control plane data at any layer lower or equal to IP.
- They may process higher layer information for Transport Network O&M or configuration purpose.

Other IP features may encompass tunnelling mechanisms (e.g. GRE, MPLS, L2TP, IPSec) or mechanisms requiring storage of state information for every flow (e.g. RSVP). Such features, if too much specific or complex, should not be required to be standard function of the transport network.

In IP architecture, a host sees only routers directly accessible (without intermediate router). In most cases (no multi-homing), there is only one such router, named First Router in the Architecture. A node acting as a router may be a First Router for other Node Bs.

If the First Router is part of the IP network of routers, it is typically named Edge Router.

In the special case when two UTRAN NEs are directly connected with a point-to-point link, taking no benefit of IP infrastructure, no intermediate router exists between both UTRAN NEs. However there are still benefits for IP (e.g. no QAAL2). This case constitutes one very specific topology solution.

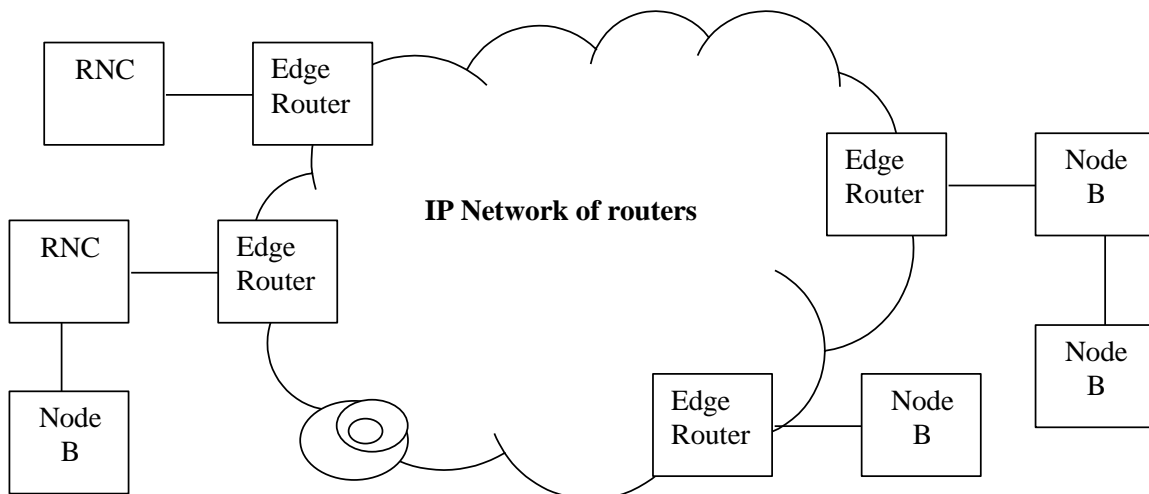

**Figure 6-29: Example Architecture for IP Transport Network**

The physical medium between one Node B and the first router is expected to be often bandwidth limited.



### 6.9.3 IPv6 aspects

The UTRAN can be a very large network, with potentially thousands of end system hosts connected to a large routed network. If public IPv4 addresses are used in this network to begin with, the work is substantial to later reconfigure this network to IPv6, when the IPv4 address space is running out, or when the operator desires to move to using the IPv6 protocol in all of his networks.

If the network is a newly built closed intranet in the first release, it is quite easy to use IPv6 from the start, since interworking with IPv4 nodes will not be needed in that case.

#### 6.9.3.1 Improved Performance

There is potential for improved performance when IPv6 is used. This is due to the following:

- 1) There are fewer header fields and optional headers compared to IPv4 (from 12 to 8) and the checksum in the IP header has been removed.
- 2) IPv6 header fields are better aligned. This also facilitates implementation in hardware.
- 3) Header compression can reduce the header size better than IPv4 under certain conditions.

Network performance is improved due to the hierarchical address architecture.

#### 6.9.3.2 Autoconfiguration

Address Management is provided using Auto-configuration. This provides the following benefits:

- 1) Lower administrative cost.
- 2) Easier renumbering.
- 3) Easier Address Management.

There are two address management schemes defined:

- 1) Stateful autoconfiguration using DHCPv6. This is also used with IPv4. Hosts obtain interface addresses and/or configuration information and parameters from a server.
- 2) Stateless autoconfiguration: Stateless autoconfiguration requires no manual configuration of host and no configuration of servers.

Stateless and stateful autoconfiguration can complement each other. The stateless approach is suitable in the case where the exact addresses a host use is not a great concern. The stateful approach is suitable when tighter control over exact address assignments is required.

#### 6.9.3.3 IPv6 to IPv4 interworking

A wide range of techniques have been identified and implemented for IPv6/IPv4 interworking. They basically fall into three categories: tunneling techniques, translation techniques, and dual stack techniques.

- Tunnels can be used for routing packets between two IPv6 hosts via an IPv4 network by adding an IPv4 header to the IPv6 packet.
- Translators are used for IPv6 to IPv4 interworking by translating the headers.
- Dual stack techniques mean that IPv4 and IPv6 co-exist in the same host.

It is likely that if an operator starts with an IPv4 UTRAN they will not change to IPv6 all at once by upgrading all IP UTRAN nodes to IPv6 at the same time. New nodes that are IPv6 capable will be added as the network grows. These IPv6 nodes must then interwork with the existing IPv4 UTRAN nodes and utilize the IPv4/IPv6 interworking techniques developed by the IETF. Particularly on the Iur, where full connectivity is required, interworking between IPv4 nodes and IPv6 nodes could require many more IPv4 addresses than the operator has left available.

Interworking techniques have disadvantages such that it is best to avoid using them if it is possible. Summaries of the main interworking techniques are provided in the following clauses.

#### 6.9.3.3.1 Network Address/Port Translators-Protocol Translators (NAPT-PT)

The use of NATs for interworking between IPv4 hosts and IPv6 hosts has similar problems as using NATs with private IPv4 addresses for extending the IPv4 address space.

In the UTRAN, bearer control (exchange of IP address/UDP port) will be performed using signalling such that IP addresses are included in the payload of signalling messages. The bearer control messages tell a UTRAN host what destination address to use to send data to the peer UTRAN host. An IPv4 host will not be able to use an IPv6 address received from an IPv6 peer host. There must be an Application Level Gateway (ALG) that intercepts the bearer control message and changes the transport parameters to the appropriate IP version. This must be done in coordination with the NAT so that the addresses in the traffic packets are changed according to the address put in the bearer control message.

ALGs and NATs are undesirable. They add complexity and degrade performance. This technique also requires that there be a pool of IPv4 addresses available that the NAT can use to translate IPv6 addresses. In addition, the NAPT-PT provides a single point of failure since all inbound and outbound traffic pertaining to a session must traverse the same NAPT-PT router. This increases costs since the reliability must be high.

The advantage of NAPT-PTs over other interworking techniques is that it allows more efficient use of IPv4 addresses. This is because one IPv4 address can be used for multiple IPv6 hosts by mapping IPv6 hosts to different UDP ports for the same IPv4 address. Other interworking techniques require an IPv4 address be mapped to an IPv6 host. One key disadvantage of NAPT-PTs is the need for ALGs.

#### 6.9.3.3.2 Stateless IP/ICMP Translation Algorithm (SIIT)

SIIT provides a method for interworking that doesn't require ALGs. However, it does require that an IPv6 host must be dynamically assigned a temporary IPv4 address that is used for the time of the session. The IPv6 host provides the IPv4 peer with the temporary IPv4 address using UTRAN bearer control. The IPv4 host uses this address for traffic packets. When the packets reach the SIIT router, the temporary IPv4 address is mapped to the IPv6 host address. The packet is then tunnelled from the SIIT router to the IPv6 host.

The IPv4 host provides the IPv6 host with an IPv4 address using UTRAN bearer control. For traffic, the IPv6 host maps this IPv4 address to an IPv6 address, which causes the packet to be routed to a SIIT router. The SIIT router will translate the mapped address back to the IPv4 address and forward it to the IPv4 host.

The SIIT technique allows multiple SIIT routers in a network so it does not cause a single point of failure like with the NAPT-PT technique.

This technique requires that the operator have a pool of IPv4 addresses available. It also requires that the traffic is routed through a SIIT router and the IP headers are translated which can have an impact on performance.

When an IPv4 address is assigned to an IPv6 node, it's necessary for the SIIT routers to be provided the address mapping between the assigned IPv4 address and the IPv6 address. This requires a protocol from the AIH server assigning the IPv4 address to the SIIT router. AIH stands for "Assignment of IPv4 Addresses to IPv6 Hosts" and is a DHCPv6 server with extensions.

#### 6.9.3.3.3 Dual stack

It is also possible for new nodes to deploy a dual stack when migrating to IPv6. The IPv4 stack can be used toward an existing IPv4 node and the IPv6 stack can be used toward IPv6 nodes.

The dual stack mechanism was designed as one part of a "transition toolbox" to support a gradual introduction of IPv6 into the existing IPv4 networks.

The dual stack mechanism is defined in [30] as "a technique for providing complete support for both Internet protocols – IPv4 and IPv6 – in hosts and routers". Also in [30], it is stated that the dual stack mechanism is "the most straightforward way for *IPv6 nodes* to remain compatible with *IPv4-only nodes*".

A dual stack mechanism consists basically of the support for both IPv6 and IPv4 in the UTRAN IP nodes. However, as stated in [64], it is possible that a dual stack node (i.e. *IPv6/IPv4 node*) may operate, in *IPv6-only* or *IPv4-only* mode; a configuration switch may implement the selection of protocol version. This is very useful in the case of introducing

UTRAN **IPv6/IPv4 nodes** in **IPv4-only** networks and in the **IPv6-only** network scenarios. Although the Dual Stack technique, as described in [30], is enough to handle the migration from IPv4 to IPv6 networks, it is still possible to use the dual stack approach in conjunction with tunneling mechanisms, as an option. This provides extra-flexibility in the configuration of the networks by the operators.

#### Address configuration

Dual stack hosts also require that the operator have a pool of IPv4 addresses still available in order to assign one to the host when it must communicate with an IPv4 host.

Since the dual stack nodes support both protocols, **IPv6/IPv4 nodes** may be configured with both IPv4 and IPv6 addresses, depending on the operation mode, i.e. if the node is in **IPv4-only operation** it requires only an IPv4 address, if the node is in **IPv6-only operation** it requires only an IPv6 address, and if the node is in **IPv6/IPv4 operation**, it requires both IPv4 and IPv6 addresses.

The **IPv6/IPv4 nodes** use IPv4 mechanisms (e.g. DHCP, manual configuration, etc) to acquire their IPv4 address and the IPv6 mechanisms (e.g. stateless address autoconfiguration, manual configuration, etc) to obtain their IPv6 address. There are other mechanisms described in [30] to acquire IPv4-compatible IPv6 addresses for the case where automatic tunneling is used by the IPv6/IPv4 nodes.

It is also necessary to keep track of which UTRAN hosts use IPv4 and which use IPv6 in order to know which type of address information to provide in the bearer control signalling.

The only possible limitation that [30] envisages for the dual stack mechanism is that in the near future scenario all of the nodes connected to both IPv6/IPv4 network would require IPv4 public addresses. This can be a problem if the operator is running out of IPv4 public addresses. However, note that the UTRAN does not require many IP addresses, so that should not be the case. Dynamic IPv4 address assignment may also be implemented by the use of a DHCPv6 server.

However, for the UTRAN case it is not an issue, since:

- 1) the UTRAN networks are private networks, not accessible to the UEs, so there is no need to use public addresses,
- 2) CIDR techniques may provide enough granularity to address several UTRAN nodes with a class C group of addresses (this can depend largely on a case by case basis), and
- 3) in case there is a need to access the UTRAN node from the Internet, NAT mechanisms may be used to translate a public address to several private addresses. The implications and potential disadvantages of NAT should be considered however.

#### DNS

In the Internet, the Domain Name Server (DNS) is used in both IPv4 and IPv6 to map between hostnames and IP addresses. A new resource record type "A6" has been defined for IPv6 addresses in [29] with support for an earlier record named "AAAA". Since **IPv6/IPv4 nodes** shall be able to interoperate directly with both **IPv4 nodes** and **IPv6 nodes**, they must provide resolver libraries capable of dealing with IPv4 "A" records as well as IPv6 "A6" and "AAAA" records. However, when a query locates an "A6/AAAA" record holding an IPv6 address, and an "A" record holding an IPv4 address, the resolver library may filter or order the results returned to the application in order to influence the version of IP packets used to communicate with that node, i.e. return only the IPv6 address to the application, return only the IPv4 address or return both addresses. This decision is implementation dependent, however, the implementation shall allow the application to control whether or not the filtering takes place.

The DNS capability in the UTRAN transport is not needed, since all the nodes and functionalities are static (i.e. it does not follow the same model as the Internet, where the content of the application can be located in several places). However, as implementation dependent, it can be used for both dual stack and **IPv6 only nodes**.

#### Complexity of dual stack implementation in comparison with IPv6-only

The term "dual stack" is somehow misleading because it is possible to misunderstand that this implies two separate HW and SW implementations in the node, one for IPv4 and one for IPv6, but as O states, "most implementations of IPv6 does not offer two completely distinct TCP/IP stacks, one for IPv4 and one for IPv6, but a hybrid stack in which most of the code is shared between the two protocol suites".

From an operator point of view, it is more complicated to connect *IPv6-only* nodes in *IPv4-only* transport network, since it would require the configuration and use of tunnels and the deployment of dual stack edge routers from the beginning of the IP UTRAN *IPv6-only nodes* introduction, making the planning quite complex in comparison with the dual stack approach in the UTRAN nodes.

### 6.9.3.4 Tunneling

Where there is only an IPv4 network available, IPv6 UTRAN traffic can be transported over the network using tunnelling. As shown in the following figure, this requires that only the first-hop routers be IPv6 capable. Techniques have been developed in the IETF to determine the appropriate tunnel endpoints.

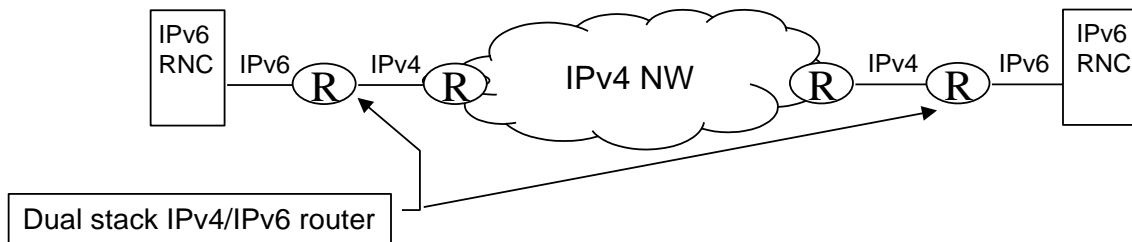

The use of tunnelling will be common in the IP UTRAN anyway for various reasons including:

- 1) Multiplexing of small packets into larger packets using PPPMUX and tunnelling with L2TP.
- 2) Virtual Private Networking for security and quality of service control.

Therefore, requiring tunnelling for transporting IPv6 packets over an IPv4 network is not a drawback.

### 6.9.3.5 Summary

There is a good case for using only IPv6 for IP UTRAN hosts:

- 1) There are advantages to deploying IPv6.
- 2) The UTRAN is a closed IP network in that UTRAN applications only communicate with each other, not to applications in other networks such as the Internet and so could be a good place to deploy IPv6.
- 3) There is a strong advantage to avoid IPv4/IPv6 transition techniques for UTRAN hosts since they add complexity and impact performance. They also require that an operator have a pool of IPv4 addresses available.
- 4) The disadvantage of using IPv6 is that, where only an IPv4 network exists, the IPv6 traffic must be tunnelled over it. However, tunnelling will commonly be used for other purposes anyway in the UTRAN transport network.

It is true that other applications in a UTRAN node besides the UTRAN applications may need transition mechanisms between IPv6 and IPv4. An example of this would be an OAM application. The following scenarios are possible:

- 1) A client could be upgraded to IPv6 and must interwork with an existing IPv4 server in the operator's network. These applications are not as sensitive to performance considerations as the UTRAN applications so the interworking mechanisms are not a problem.
- 2) The servers could be upgraded to IPv6 along with the clients.
- 3) The clients could be run on hosts different than those of the UTRAN applications and continue to use IPv4 to avoid the need for interworking.

Also, the Release 99 / Release 4 Iu interface already supports IPv4. For this interface, a dual stack should be required though it should be recommended that the Iu interface be upgraded to IPv6 when the IP UTRAN is deployed.

Inter-working between IPv4 and IPv6 is possible and will have to be mastered by operators, like ISPs, and vendors. However, when this inter-working can be avoided, it simplifies the overall IP network management and configuration.

One case avoiding any interworking is to deploy new IP networks with IPv6 only, when new equipment has to be installed to build it. Reasons why the standard shall allow using IPv4 equipments, when they are available are:

- since IP technology is a good solution to mix several applications on the same common infrastructure, re-use of existing IP networks shall be possible;
- no specific feature of IPv6 is required by the RNL. No addressing shortage is expected when a private network is used for UTRAN;
- allowing IPv4 makes IP Transport in UTRAN deployment independent from any IPv6 deployment.

## 6.10 Backward compatibility with R99-R4/Coexistence with ATM nodes

It should be investigated how to inter-work the user plane between IP and AAL2/ATM interfaces including inter-working with a node that supports only AAL2/ATM interfaces, and how to interwork the control plane between IP and ATM interfaces.

### 6.10.1 General

An IP UTRAN node should not be required to support AAL2/ATM UTRAN interfaces in order to interoperate with AAL2/ATM UTRAN nodes. The solution for interoperating between a UTRAN node with only IP interfaces and a Release 99/ Release 4 and later AAL2/ATM UTRAN node should be performed only in the transport network layer (TNL) in order to maintain transport independence for the Radio Network Layer. The separation of RNL and TNL is an architectural principle in [1]. This means that the UTRAN RNL applications must not be affected nor should any interworking be required in the UTRAN RNL control plane or user plane when interworking between different transport technologies.

As shown in figure 6-30 there are principally 3 cases (3-5) where interworking between IP and ATM nodes on Iub and Iur is necessary.

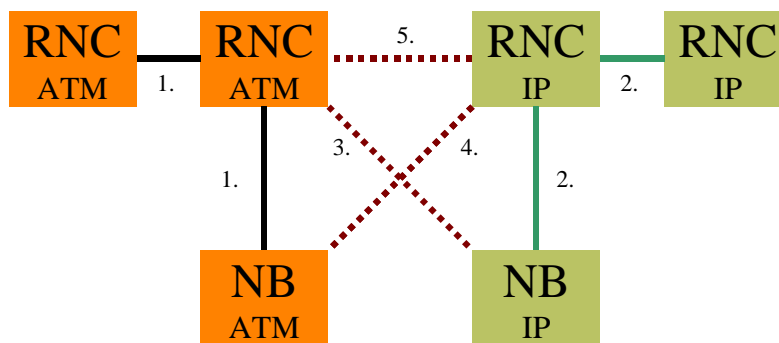

**Figure 6-30: Interworking cases**

The cases of interconnecting can be summarized as follows:

- Iub/I-r – All A2
- Iub/I-r – All I3
- I-b – ATM RNC with IP Node4
- I-b – IP RNC with ATM Node B
- I-r – IP RNC with ATM RNC.

When an operator is migrating from ATM to IP, for example, a newly deployed UTRAN node should be allowed to support only IP interfaces and still be able to interwork with ATM UTRAN nodes. It should not be required to support AAL2/ATM UTRAN interfaces in order to interoperate with AAL2/ATM UTRAN nodes. This is the case for the following reasons

1. Otherwise, all Release 5 RNCs having connectivity with both ATm NEs and Ip NEs terminating RNL protocols would need to support both types of interfaces
2. There may be manufacturers that want to supply only UTRAN nodes with one transport technology (such as IP-only nodes) but interwork with existing ATM nodes terminating RNL protocols in the operators network
3. When an operator is migrating from ATM to IP, the newly deployed nodes would need to also support ATM interfaces to interwork with the legacy ATM nodes terminating RNL protocols. This means that the ATM network is being extended, which defeats the original purpose.

### 6.10.2 Interworking Options

A design goal for the IP transport option within Rel.5 is to minimize the effects on the RNL ([1], clause 5.2). The fact that an Release 99 / Release 4 node can be connected without having been upgraded to Rel.5 must be taken into account.

In the following three potential interworking options (dual stack operation, and TNL IWU) should be considered:

#### 6.10.2.1 Dual Stack operation within Rel.5 RNCs

Within the dual stack option a Rel.5 RNC must provide both stacks. Generally, it is assumed that only RNCs should provide both types of interfaces, so that Node Bs are either IP or ATM nodes. Nevertheless, for interworking case 3, where an IP based Node B is connected with a Release 99 / Release 4 RNC, also an interworking on Iub would be necessary. Within a pure IP or ATM environment the RNC must only provide one type of interface.

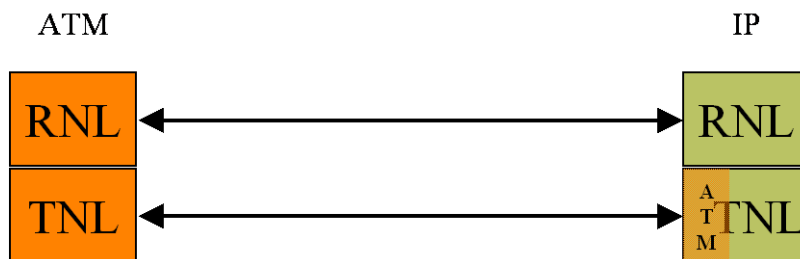

Figure 6-31: Dual Stack operation within Rel.5 RNCs

A Rel.5 IP node that needs to communicate with a pure ATM node (R99 or later) requires the complete ATM/AAL2 protocol stack. Beneficial of such an dual stack solution is, that it does not require a TNL control protocol on IP side.

On Iub this solution would be quit sufficient, but on Iur there may be certain cases where a simple IWF or dual stack operation are not sufficient and an interworking unit (IWU) will be needed. (If interworking case 3 and 4 should be supported, also on Iub an IWU would be needed.)

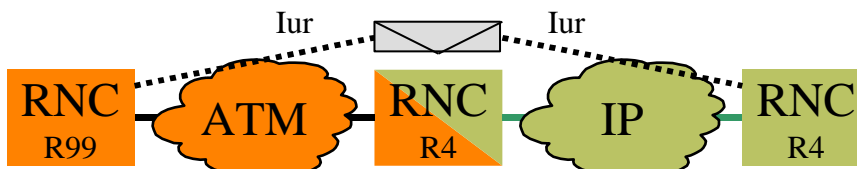

Figure 6-32: Full Meshed Iur

In the network, that is shown in figure 6-32, are some RNCs pure IP based, some RNCs are pure ATM based and some RNCs are dual stacked. Assuming a network configuration where a pure IP based RNS borders on a pure ATM based RNS, the Iur interface between both RNSs must be supported.

A dual stacked RNC with an IWF in the middle would be able to communicate on both networks but would not be able to combine both parts of the network. In that case either an interworking unit is needed or a solution to transport ATM-

traffic through the IP-backbone. Such a solution, based on Pseudo-Wire Emulation Edge to Edge (PWE3) [70] [71], is provided in the next paragraph.

6.10.2.1.1 Interworking with PWE3-capable ATM Switch

A PE node as defined in [71], an ATM switch equipped with interfaces to both the ATM and the IP network, connects the ATM and the IP-backbone. The PE-node acts as a PWE3-capable node towards the IP-backbone and establishes a tunnel with the RNC-with PWE3 for interconnection with the RNC-R99.

RNC-with PWE3 communicates with RNC-R99 via its AAL2/AAL5 protocol stack on top of PWE3 layer over the PWE3 tunnel through the IP-backbone. The PWE3 tunnel terminates in the PE-node, from where plain ATM-traffic is forwarded to RNC-R99 over the ATM-backbone w/o termination of the Adaptation Layer. All planes (Control plane designated as xxAP in the figure Transport Network Control Plane (Q2630) and user plane (designated as Vc/Dt in the figure) shall be carried over PWE3.

The TNL Control Plane protocol used in this solution is thus the ALCAP Q2630 tunnelled over PWE3 used as layer 1. A PE-node relays the Q2630 messages encapsulated in SS7/AAL5 like any other ATM switch that is potentially placed in the transport network between the PWE-capable RNC and the next adjacent node terminating the Q2630 stack.

Similarly, a PE-node relays the User Plane messages encapsulated in AAL2/ATM like any other ATM switch that is potentially placed in the transport network between the PWE-capable RNC and the next adjacent node terminating the Q2630 stack.

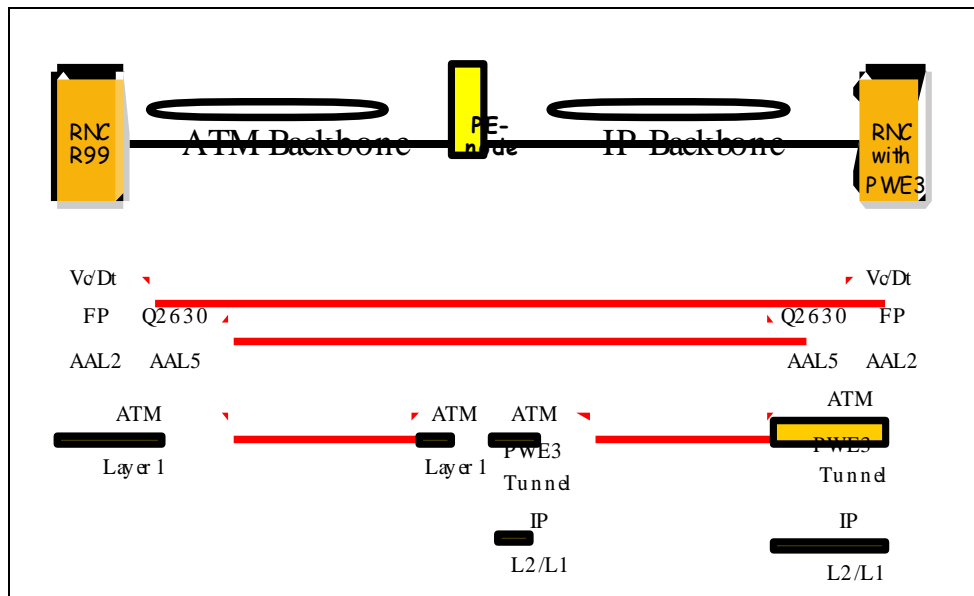
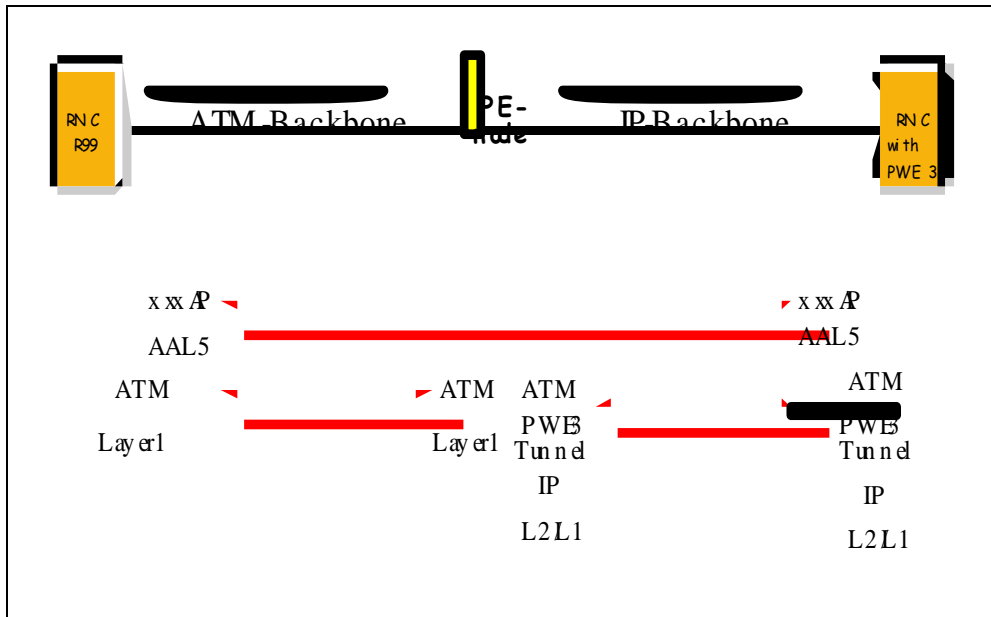

Figure 6-32a: Interworking with a PWE3-capable ATM Switch

A PE-node relays also the xxAP Control Plane messages encapsulated in AAL5/ATM like any other ATM switch that is potentially placed in the transport network between the PWE-capable RNC and the ATM RNC.



**Figure 6-32b: Interworking with a PWE3-capable ATM Switch**

The three options of PWE3 tunneling protocol [71] over IP networks can be done either directly over IP layer or over L2TP [38] or MPLS.

The following figure shows the protocol stack at the RNC/CN-node, in the case the RNC/CN-node cannot be connected to the ATM backbone and implements PWE3.

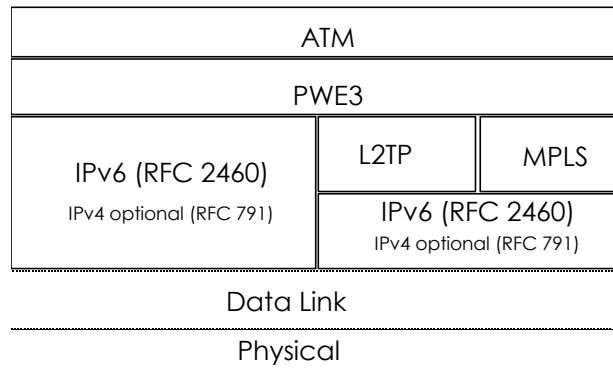

**Figure 6-32c: Bearer for Control plane (RANAP), Transport Network control plane (ALCAP) and user plane with PWE3 tunneling protocol.**

The method(s) to be used for encapsulation of ATM cells, namely, One-to-one mode and N-to-one mode, is(are) FFS. The transport service to be used, namely the ATM VCC Cell Transport Service or the ATM VPC Cell Transport Service, is FFS.

The use of the ATM AAL5 CPCS-SDU and AAL5 PDU frame modes is not required.

The signalling flows corresponding to this ATM-IP interworking method are presented in section 6.10.5.5.

### 6.10.2.2 Transport Network Layer IWU

Also an TNL IWU can either be placed somewhere between the connecting nodes or can be integrated within one node.



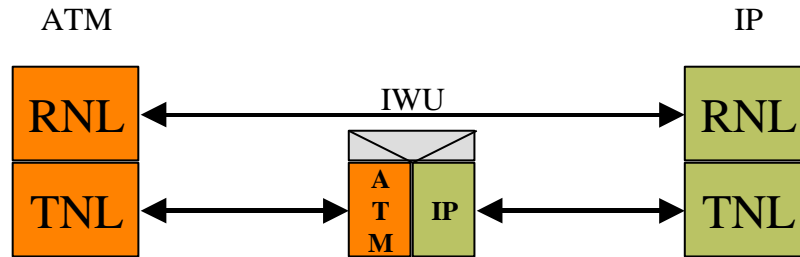

**Figure 6-33: Transport Network Layer IWU**

On transport network layer the IWU must support the translation between ATM and IP transport formats and QoS requirements. It must hold all states of active connections.

Although it is conceivable that a pure IP TNL could work without a TNL control protocol a simple TNL IWU would probably require a TNL control protocol. At least this depends on the agreed addressing scheme for the IP transport.

#### 6.10.2.2.1 Issue on TNL IWU control protocol

The following two figures show an example of a radio link setup request on Iur between an Release 99 / Release 4 and Rel.5 IP RNC. The first example, where the SRNC is a Release 99 / Release 4 and the DRNC is a Rel.5 IP RNC, avoids the usage of an TNL control protocol due to an appropriate choice of the binding ID and transport layer address within the RNSAP messages. In the second example, where the SRNC is a Rel.5 IP and the DRNC is a Release 99 / Release 4 RNC, the usage of a TNL control protocol is unavoidable.

Figures 6-34 and 6-35 show the relevant information exchange on RNSAP and the involved primitives and messages of the AAL2 signalling protocol regarding [2] for each example.

In the first example the Release 99 / Release 4 SRNC requests a radio link setup. The Rel.5 DRNC RNL requests from its TNL resources for the new connection and receives an appropriate transport layer address and a binding ID. For example, the BID would be the UDP port, where the TNL is waiting for the new connection, and the transport layer address (TLA) would be a code point (CP) that terminates at the IWU and identifies the DRNC. Therefore the Rel.5 TNL must have the knowledge that it is communicating with an ATM node. It provides a CP instead of an IP address and encodes the necessary information in a way that allows the IWU to establish the IP path later on. Within the radio link setup response message the UDP port number can be transported within the binding ID. Both information's, TLA and BID, are transmitted via ALCAP to the IWU. The IWU maps code points to IP addresses and extracts the port number out of served user generated reference (SUGR). The mapping between code points and IP addresses must be configured by O&M within the IWU and within the TNL of the IP node. The IWU is then able to establish a UDP connection and to complete the ALCAP connection setup. Some ATM specific information's like the link characteristics get either lost or translated into an IP equivalent IE.

Failure behaviour is FFS.

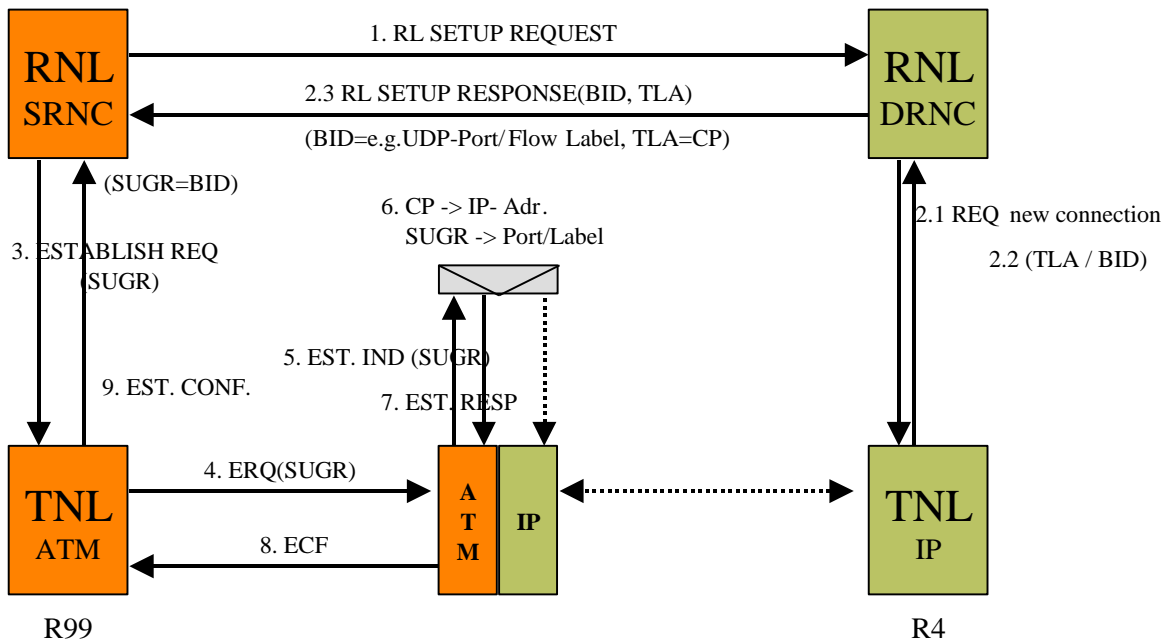

Figure 6-34: Example 1: RNSAP: DCH RL Setup, SRNC = R99/R4; DRNC = Rel.5

NOTE: In this case the IWU must always send data to the DRNC before the DRNC can transmit data towards the SRNC because the DRNC does not know to which IP address/UDP port to send data before receiving this first data.

In the case where the Rel.5 IP RNC requests a radio link setup from the Release 99 / Release 4 RNC, the Release 99 / Release 4 RNC is not aware of the fact that it is communicating with an IP node. Beside, it must choose the binding ID completely free (e.g. without the knowledge what ports are free on the IWU or the IP RNC). The Rel.5 SRNC can map the TLA to an appropriate IP address but it can not map the binding ID to an appropriate UDP port number. Trying to map the binding ID to the port numbers results either in assigning a large number of IP addresses to both, the IP RNC and the IWU, or restricting the binding ID space within the Release 99 / Release 4 RNCs. Even if a trade off between numbers of needed IP addresses and restrictions of the binding ID space could be found, information like the link characteristics that can't be generated within the IWU itself must be transmitted somehow to the IWU. For that purpose a TNL control protocol also on the IP side of the connection is necessary.

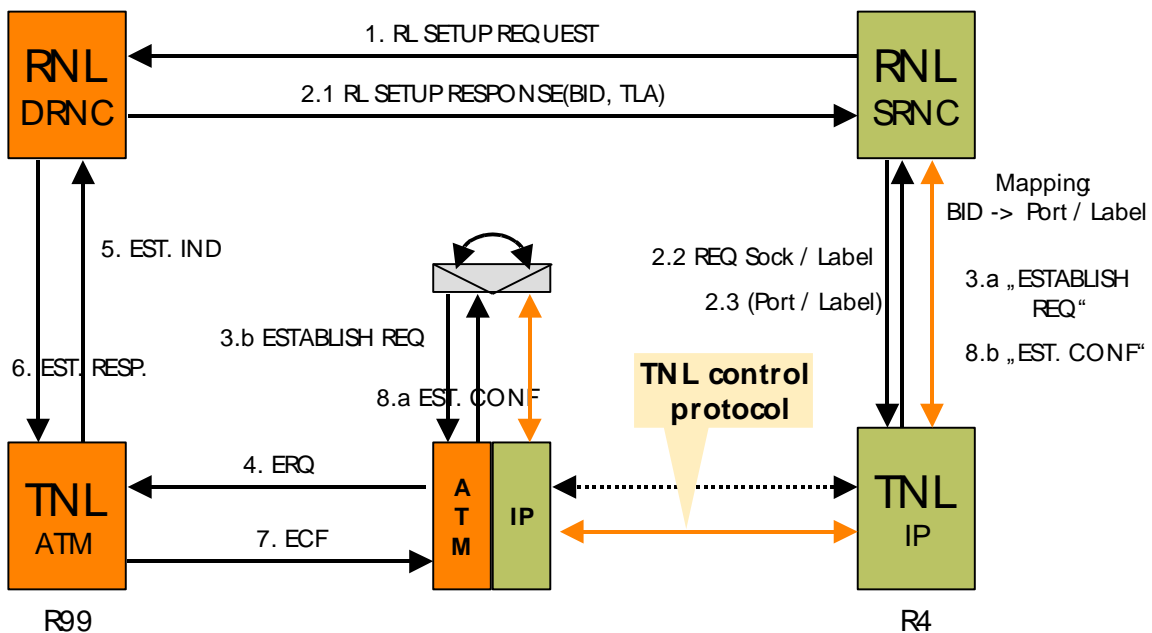

Figure 6-35: Example 2: RNSAP: DCH RL Setup, DRNC = R99/R4; SRNC = Rel.5

Candidates for this IP -based TNL control protocol (IP-ALCAP) are described in sections 6.10.5.1 to 6.10.5.4.

### 6.10.3 Conclusion

It must be clarified if an interworking on Iub (interworking case 3 and 4) should be supported or if an dual stack operation is sufficient for the Iub interface.

For the Iur interface, when the IP RNC has no access to the ATM network, either:

- an IWU is needed, -which is either integrated within the IP RNC or in an independent box-
- or alternatively, a PWE3 tunnel protocol can be used between the IP RNC and an ATM switch used in the transport network to make a tunnel towards the ATM RNC.

An IWU that works only on TNL requires a TNL control protocol that must be specified within the standard. The solutions using such an independent IWU and a dedicated IP-based TNL Control Protocol are presented in section 6.10.5.1 to 6.10.5.4. The solution using the ATM switch with the PWE3 tunnel protocol is presented in 6.10.5.5.

### 6.10.4 UTRAN Architecture considerations

The following figures show the Iur interface where an IP UTRAN node is introduced. They are shown as interworking examples for the purpose of this discussion. In figure 6-36, a Release 99 / Release 4 SRNC is shown with an Iur interface to an IP DRNC. In figure 6-37, an IP SRNC is shown with an Iur interface to a Release 99 / Release 4 DRNC.

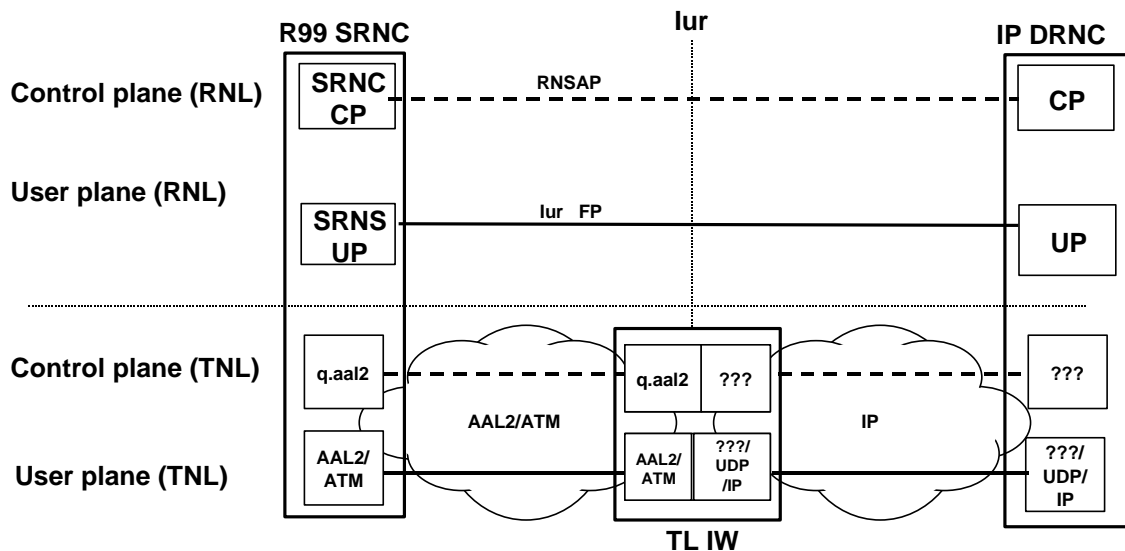

Figure 6-36: Transport network layer interworking with Release 99/ Release 4 SRNC

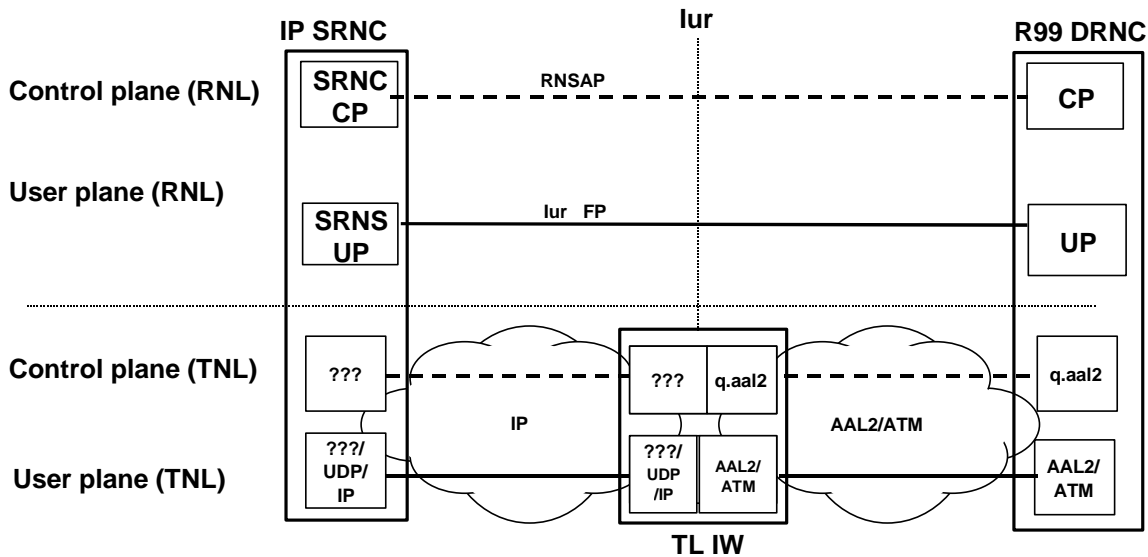

Figure 6-37: Transport network layer interworking with IP SRNC

These figures show the separation between the RNL control plane, the RNL user plane, the TNL control plane, and the TNL user plane. The IP protocols and the need for a TNL control plane protocol in the IP domain are yet to be determined so they are shown with question marks.

The following statements concerning interworking can be made based on the discussion and examples above:

- 1) IP and AAL2/ATM UTRAN nodes use different address and flow identification types. The appropriate types must be provided to the appropriate nodes when establishing a transport bearer.
- 2) A Release 99 / Release 4 SRNC will initiate q.aal2 connection signalling and expect a response when establishing a transport bearer.
- 3) A Release 99 / Release 4 DRNC will expect to receive q.aal2 connection signalling when a transport bearer is being established by the SRNC.
- 4) A transport network interworking function is required in the transport network. This function could be implemented in a third node with both IP and AAL2/ATM interfaces, for example.

### 6.10.5 ATM/IP Interworking solution proposals

This section describes the signalling flow for several candidate solutions enabling an IP node to interwork with a legacy ATM node.

It first describes in subsections 6.10.5.1 to 6.10.5.4 the signalling flow for the candidate solutions based on the third interworking option i.e. solutions using a TNL IWU as presented in section 6.10.2.2.

Then in section 6.10.5.5, it presents the signalling flow for the interworking solution based on a PWE3-capable ATM switch that fulfils the same requirement.

#### 6.10.5.1 Bearer control proposal using IETF SIP/SDP

For exchanging transport layer information between IP UTRAN nodes, the RNL signalling should be used (RANAP, RNSAP, NBAP) without a Transport Network Control Protocol.

For establishing transport connections between an IP UTRAN node and an ATM UTRAN node, a Transport Network Layer interworking function should be used in the transport network. This function would be implemented in a third node (such as an RNC) that has both ATM and IP interfaces.

In order to interwork with the q.aal2 signalling used by the AAL2/ATM node, an IP ALCAP will be used.

6.10.5.1.1 Description

It is proposed to use Session Initiation Protocol (SIP) signalling with Session Description Protocol (SDP) parameters. SDP [58] supports both IP and ATM parameters. SIP [57] is proposed since it is an IETF signalling protocol and is used to carry SDP.

Since a node must know what type of interface to communicate with, a Network Type parameter should be added to the RNL signalling. The following table shows how the Network Type parameter is used.

R99/R4	R5 IP	R5 ATM	Action
SRNC	DRNC		R5 DRNC knows the SRNC is Release 99 / Release 4 because of missing transport parameters in RL setup req. R5 IP RNC does interworking steps.
DRNC	SRNC		SRNC sends IP transport parameters that Release 99 / Release 4 DRNC will ignore. SRNC must know that it is receiving ATM parameters. Absence of network type in response will indicate that it is Release 99 / Release 4. R5 IP RNC does interworking steps.
SRNC		DRNC	R5 DRNC knows SRNC is Release 99 / Release 4 because of missing transport parameters in RL setup req.
DRNC		SRNC	SRNC sends ATM network type parameter that Release 99 / Release 4 DRNC will ignore. SRNC must know that it is receiving ATM parameters from DRNC. Absence of network type will indicate that it is Release 99 / Release 4.
	SRNC	DRNC	SRNC sends IP transport parameters. SRNC must know that it is receiving ATM parameters. It can know this from the network type parameter in DRNC response. SRNC then performs interworking steps.
	DRNC	SRNC	SRNC sends ATM network type. R5 DRNC knows its ATM from the network type and performs interworking steps.

6.10.5.1.2 Bearer control between IP and ATM nodes signalling examples

The following figures provide signalling diagrams that show how the interworking can be achieved with this proposal. The Iur is shown as an example. UDP ports are shown for connection identifiers as an example.

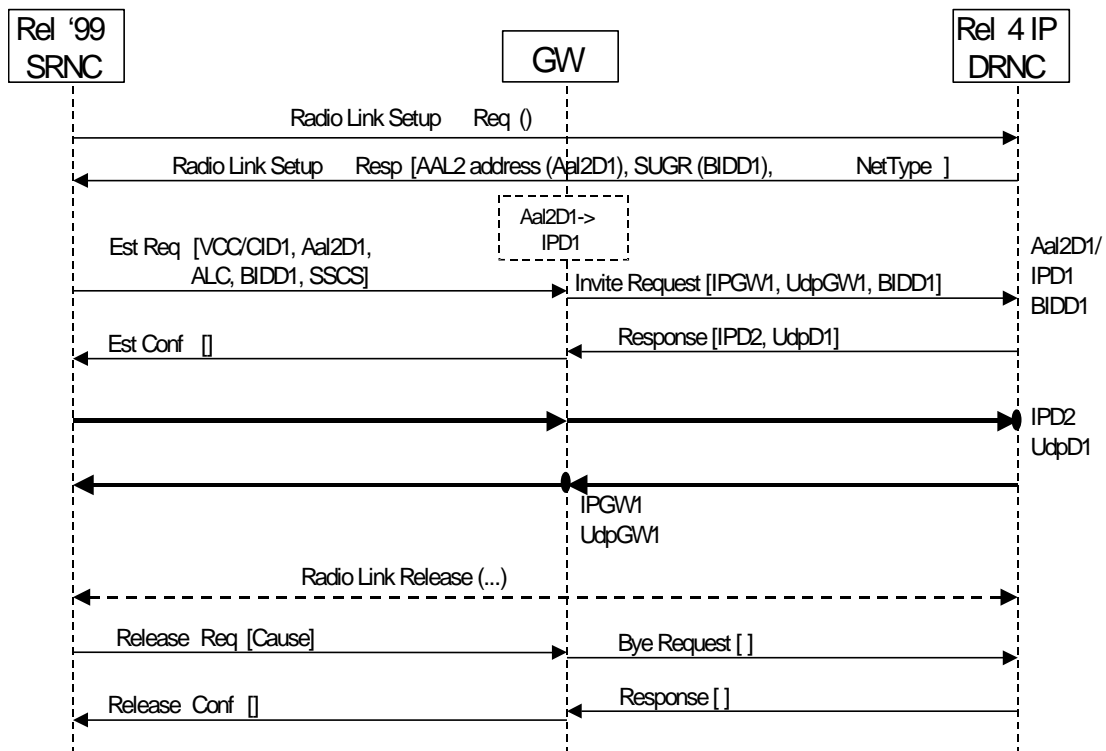
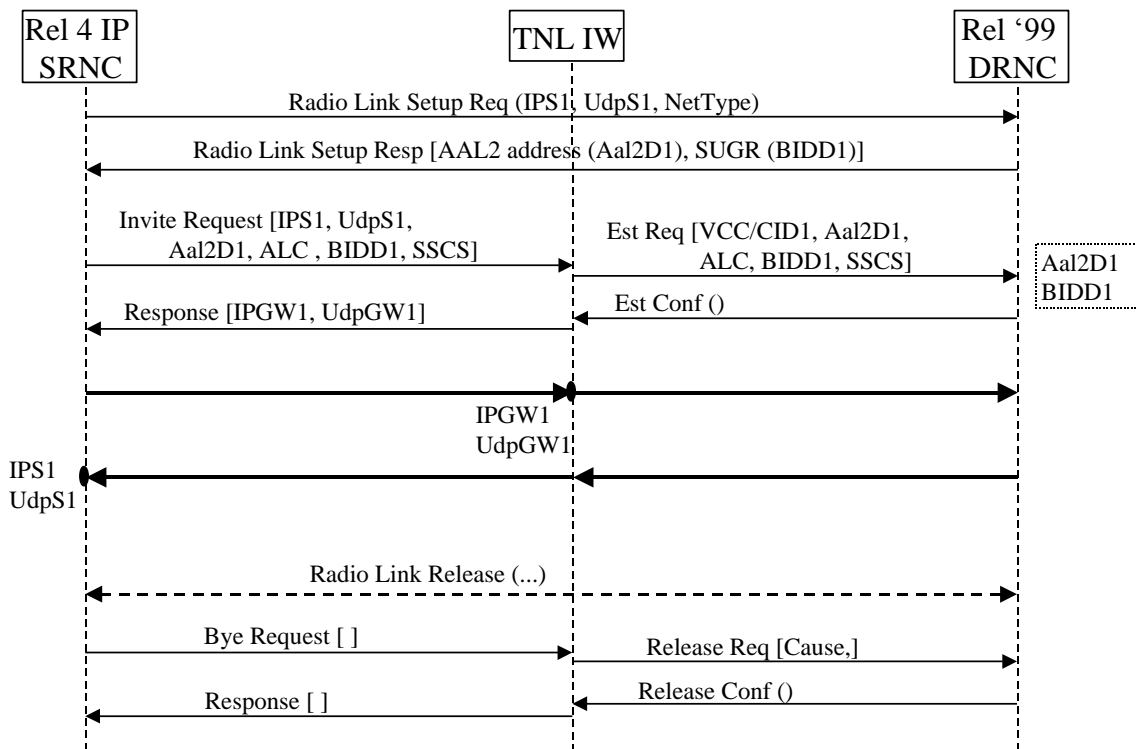

Figure 6-38: Interworking between an AA2/ATM SRNC and an IP DRNC

NOTE 1: The Release 99 / Release 4 SRNC sends radio link setup. There is an SCTP Signalling Gateway for interworking the SCTP/IP signalling to ATM signalling.

- NOTE 2: The IP DRNC node responds with ATM transport parameters. The IP DRNC must have both ATM and IP addresses assigned to it.
- NOTE 3: The SRNC uses q.aal2 signalling to establish a connection towards the DRNC based on the address received in the RL Setup Response. The TNL IW node is along the route to the DRNC.
- NOTE 4: When the TNL IW function receives the q.aal2 set up message it determines that the destination node is an IP node.
- NOTE 5: The TNL IW function translates the ATM address to the IP address for the DRNC and sends a SIP Invite message to the IP DRNC. The Invite message includes the IP address and UDP port for traffic toward the TNL IW node. Also included is the binding ID so that the DRNC can correlate the transport signalling with the RNL signalling.
- NOTE 6: The IP DRNC responds to the Invite message. Included in the response message is the IP address and UDP port for traffic towards the IP DRNC.
- NOTE 7: When the TNL IW node receives the Response message it sends the q.aal2 confirmation message to the ATM SRNC.
- NOTE 8: To release the connection, the SRNC sends a q.aal2 Release Request.
- NOTE 9: When the TNL IW function receives the request it sends a SIP Bye Request to the IP DRNC.
- NOTE 10: The IP DRNC responds to the Bye Request and when the TNL IW function receives it, it sends the q.aal2 Release Confirm.



**Figure 6-39: Interworking between an AA2/ATM SRNC and an IP DRNC**

- NOTE 11: The rel 4 SRNC sends radio link setup. An SCTP Signalling Gateway is used for interworking the SCTP/IP signalling and ATM signalling. The Setup message includes IP address, UDP port, and network type that will be ignored by the Release 99 / Release 4 DRNC.
- NOTE 12: The ATM DRNC node responds with the ATM transport parameters.
- NOTE 13: The SRNC sends a SIP Invite message to the TNL IW node. It includes the IP address and UDP port to be used for traffic towards itself. It also includes the ATM parameters received from the ATM DRNC so that the TNL IW function can establish an AAL2 connection with the ATM DRNC.

NOTE 14: The TNL IW function initiates a q.aal2 establish request based on the parameters received from the SRNC.

NOTE 15: The ATM DRNC responds to the q.aal2 establish message.

NOTE 16: When the TNL IW node receives the establish confirm message it sends a SIP response message to the IP SRNC. The response includes the IP address and UDP port used for traffic towards itself.

NOTE 17: To release the connection, the SRNC sends a SIP Bye Request.

NOTE 18: When the TNL IW function receives the request it sends a q.aal2 Release Request to the ATM DRNC.

NOTE 19: The ATM DRNC responds to the Release Request.

NOTE 20: When the TNL IW function receives it, it sends SIP response.

### 6.10.5.1.3 Use of SIP for Interworking between UTRAN ATM interfaces and UTRAN IP interfaces

#### 6.10.5.1.3.1 Description

##### 6.10.5.1.3.1.1 Inter Working Problem Summary

It is required that interworking be possible between an IP UTRAN node (or MSC) that does not have any ATM interfaces and an ATM UTRAN node (or MSC). The motivations for this requirement are described in clause 5 of the present document.

##### 6.10.5.1.3.1.2 Approach/Aims

The solution to the Interworking requirement should be such that there is a minimum set of requirements placed on the IP node. The IP node should as much as possible be able to act as if it is talking to another IP node. A Signalling Gateway is assumed for interworking the SCTP/IP signalling to ATM signalling.

The TNL-IWF should receive either a Q.AAL2 establish request or a SIP Invite request message and be able to generate the other message based on the information that is in the message and a table of associations. The IP node should not need to make any ATM configuration decisions. Any ATM (AAL2) configuration should be done by the TNL-IWF.

##### 6.10.5.1.3.1.3 Using SIP as a Transport Bearer Signalling Protocol

SIP is a protocol that is specifically designed for the establishment of IP sessions for many different types of applications. It is an IETF protocol developed by the MMUSIC working group for creating, modifying and terminating sessions. SIP invitations contain session descriptions that allow participants to agree on a set of compatible session parameters. The session descriptions are described using SDP. SIP has scope for much more functionality than is required here, and is aimed for use as a multimedia session control protocol. However, a basic implementation of SIP, carefully defined so as to unambiguously describe the usage of the protocol for this application would meet the requirements for an IP ALCAP.

##### 6.10.5.1.3.1.4 Implementation

Compliance with SIP places some requirements on the TNL-IWF and the communication between the TNL-IWF and the IP UTRAN (or MSC) Node.

##### 6.10.5.1.3.1.4.1 ACK message

In addition to the Invite request and Response messages, an ACK message is required by SIP to confirm the session. In clause 6.5 of [1] there should be an ACK message after receipt of the SIP response message for figures 30 and 31. The ACK message should always be in the same direction as the original Invite Request message.

The corrected diagrams and associated description are shown below:

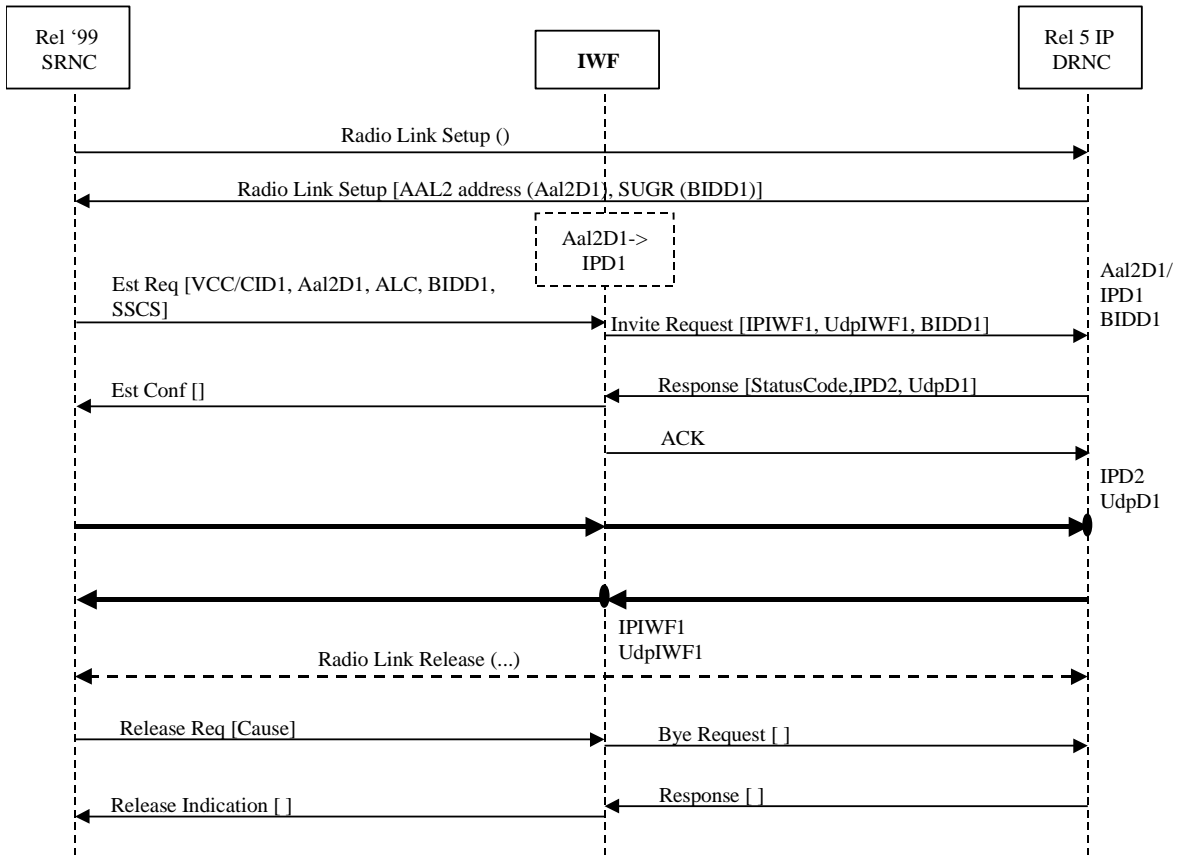

**Figure 6-40: Interworking between an AAL2/ATM SRNC and an IP DRNC**

- NOTE 1: The Release 99 / Release 4 SRNC sends radio link setup. There is an SCTP Signalling Gateway for interworking the SCTP/IP signalling to ATM signalling.
- NOTE 2: The IP DRNC node responds with ATM transport parameters. The IP DRNC must have both ATM and IP addresses assigned to it.
- NOTE 3: The SRNC uses q.aal2 signalling to establish a connection towards the DRNC based on the address received in the RL Setup Response. The TNL IWF is along the route to the DRNC.
- NOTE 4: When the TNL IWF receives the q.aal2 set up message it determines that the destination node is an IP node.
- NOTE 5: The TNL IWF translates the ATM address to the IP address for the DRNC and sends a SIP Invite message to the IP DRNC. The Invite message includes the IP address and UDP port for traffic toward the TNL IWF. Also included is the binding ID so that the DRNC can correlate the transport signalling with the RNL signalling.
- NOTE 6: The IP DRNC responds to the Invite message. Included in the response message is the IP address and UDP port for traffic towards the IP DRNC.
- NOTE 7: When the TNL IWF receives the Response message it sends the q.aal2 confirmation message to the ATM SRNC. It also sends an SIP ACK message to confirm the IP bearer connection.
- NOTE 8: To release the connection, the SRNC sends a q.aal2 Release Request.
- NOTE 9: When the TNL IWF receives the request it sends a SIP Bye Request to the IP DRNC.
- NOTE 10: The IP DRNC responds to the Bye Request and when the TNL IWF receives it, it sends the q.aal2 Release Confirm.



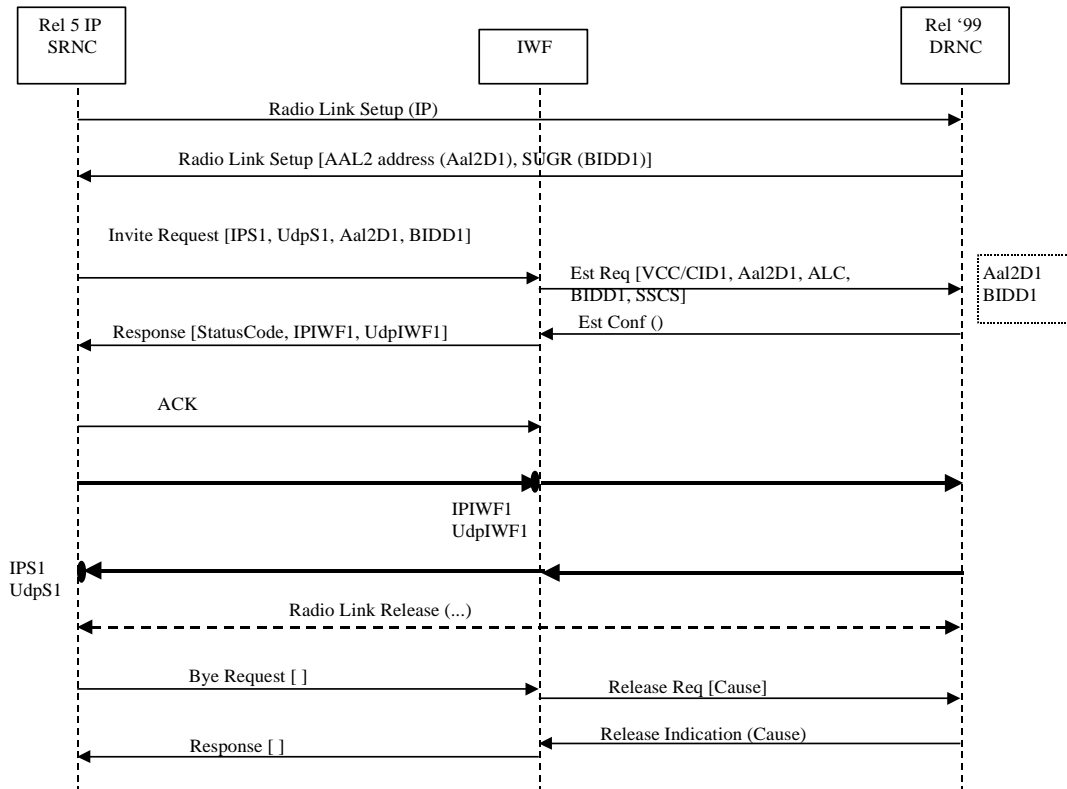

**Figure 6-41: Interworking between an AAL2/ATM SRNC and an IP DRNC**

NOTE 11: The rel 5 IP SRNC sends radio link setup. An SCTP Signalling Gateway is used for interworking the SCTP/IP signalling and ATM signalling. The Setup message includes IP address, UDP port, and network type that will be ignored by the Release 99 / Release 4 DRNC.

NOTE 12: The ATM DRNC node responds with the ATM transport parameters.

NOTE 13: The SRNC sends a SIP Invite message to the TNL IWF. It includes the IP address and UDP port to be used for traffic towards itself. It also includes the ATM parameters received from the ATM DRNC so that the TNL IWF can establish an AAL2 connection with the ATM DRNC.

NOTE 14: The TNL IWF initiates a q.aal2 establish request based on the parameters received from the SRNC.

NOTE 15: The ATM DRNC responds to the q.aal2 establish message.

NOTE 16: When the TNL IWF receives the establish confirm message it sends a SIP response message to the IP SRNC. The response includes the IP address and UDP port used for traffic towards itself. The IP SRNC then confirms with an SIP ACK message.

NOTE 17: To release the connection, the SRNC sends a SIP Bye Request.

NOTE 18: When the TNL IWF receives the request it sends a q.aal2 Release Request to the ATM DRNC.

NOTE 19: The ATM DRNC responds to the Release Request.

NOTE 20: When the TNL IWF receives it, it sends the SIP response.

#### 6.10.5.1.3.1.4.2 Communication of endpoint information and session identification

The signalling shown in clause 6.10.5.1.3.1.4.1 shows the SIP Invite Request message being used to pass certain parameters. These parameters are required to indicate the endpoints of the session being established. The following clauses define the use of the SIP fields and SDP parameters to be used in these SIP messages.

## 6.10.5.1.3.1.4.2.1 SIP header fields

SIP messages are structured in a HTTP like way as defined in the SIP RFC [57] with a number of mandatory and optional fields. The mandatory fields (ie; they must be present in a SIP message) are:

SIP header	Contains	Use in UTRAN
Allow:	1#Method	only required in a 405 response message
Call-ID:	<session identifier>	The binding id is communicated here
Contact:	"sip:" <username>@<host> [ ":" <port> ]	Username=source E164 address Host = src IP address or domain name Port = source SCTP port
Content length:	<length in octets>	Length in octets of the message
Content Type:	<media-type>	"application/sdp"
Cseq:	<sequence number> <method>	Sequence number < 2**31 Eg: Cseq: 4711 INVITE
From:	"sip:" <username>@<host> [ ":" <port> ]	Username=source E164 address Host = src IP address or domain name Port = source SCTP port
To:	"sip:" <username>@<host> [ ":" <port> ]	Username= destination E164 address Host = destination IP address or domain name Port = destination SCTP port
Via:	<protocol-sent> <source ip> ":" <port>	Protocol-sent="SIP2.0/SCTP" Source ip = src IP address Port = src port address

The Call-Id along with the From and To fields constitutes a *Call leg*.

Other fields are optional and should not be mandated for the UTRAN application.

## 6.10.5.1.3.1.4.2.2 SDP parameters

The following SDP parameters are mandatory (must be present) as according to RFC 2327.

- V – version of SDP. This should be set to zero.
- O – this information represents the identity of the sender of the message. Username is left as "-" when the concept of users is not supported by the application. The session id needs to be a globally unique identifier that can be generated by any mechanism (ie random number, network time protocol, etc). For the UTRAN, this value will be set to the Binding ID received via the RN protocol (ie RNSAP/NBAP/RANAP). Version here refers to the version of the message and must be incremented each time (recommendation is to use an NTP timestamp). The network type is IN for internet and the address type is IP6 or IP4. The Address is the origin's address.
- S – this is an arbitrary string to associate with the session.
- T – this is the time of the session. With the stop time set to zero indicates that the session is not bounded. The start time must be specified however (otherwise the session is regarded as permanent).
- E – email address. The email address of the source (Inviter). Either this field or the p field (phone number) MUST be sent to comply with the SDP protocol. This field may be used to send the same information as the "contact" field in the SIP header.

All other SDP parameters are optional according to [58]. The following parameters however are required and defined as follows for the UTRAN application of the SIP protocol as an IP ALCAP.

- 1) C=IN IP6 <src IP6address> or, for Ipv4 option: c= IN IP4 <srcIP4address>
- 2) this is information associated with the connection. Essentially it is a description of the network layer address that must be used to send data to.

M= application <udpport> udp/<IuxFP> <value>

- 3) describes the media used for the session and provides the transport address. For this application, the media is an "application", will use a udp port assigned by the sender of the message, a transport protocol field (either IuFP, IurFP or IubFP) and a fmt type must be chosen. Values 96 – 127 are user definable for fmt type.

A=fmtp: <value> <parameters>

- 4) zero or more media attribute lines. This attribute is the main mechanism available in SDP to allow the extension of SDP and the tailoring of its use for particular applications. <value> should match with <value> in the m= line. <parameters> can be used to convey information describing the format of the media. In the case of the UTRAN application, this is proposed to convey some of the service requirements of the payload. This will consist of nine parameters as follows:
- maximum FP-DU size(Framing Protocol Data Unit packet size including FP headers);
  - average FP-DU size;
  - maximum bit rate;
  - average bit rate;
  - path TYpe.

These parameters are calculated based on the requirements of the RNL on the TNL as specified in the 3GPP specifications for the RNL and must be given for both uplink and downlink. The actual format of this message for the UTRAN application is:

a=fmtp: <value> MaxSizeUp AvSizeUp MaxRateUp AvRateUp MaxSizeDn AvSizeDn MaxRateDn AvRateDn, PathType

where <value> is as previously defined and:

MaxSizeUp	Maximum FP-DU size for the uplink.
AvSizeUp	Average FP- DU size for the uplink
MaxRateUp	Maximum Bitrate for the uplink
AvRateUp	Average Bitrate for the uplink
MaxSizeDn	Maximum FP-DU size for the downlink
AvSizeDn	Average FP- DU size for the downlink
MaxRateDn	Maximum Bitrate for the downlink
AvRateDn	Average Bitrate for the downlink
Path Type	Path Type

#### 6.10.5.1.3.1.4.2.3 Example message

An example SIP Invite request could be represented as the following:

INVITE sip: [A2EA2@Iputrannode2.operator.net](mailto:A2EA2@Iputrannode2.operator.net)

Via: SIP/2.0/SCTP 194.237.226.242:5062

From: sip: [A2EA1@iwf1.operator.net](mailto:A2EA1@iwf1.operator.net)

To: sip: [A2EA2@Iputrannode2.operator.net](mailto:A2EA2@Iputrannode2.operator.net)

Call-ID: <BIDD1>

CSeq: 1 INVITE

Contact: sip: [A2EA1@iwf1.operator.net:5062](mailto:A2EA1@iwf1.operator.net:5062)

Content-type: application/sdp

Content-length: 141

v=0

o= - <bidd1> 924526776692 IN IP4 194.237.226.242

s= -

e= [A2EA1@iwf1.operator.net](mailto:A2EA1@iwf1.operator.net)

c=IN IP4 194.237.226.242

t=76554467889 0

m=app 7094 UDP/lubFP 96

a= fmp: 96 41 38 16400 8550 41 38 16400 8550

where:

A2EA1 = E164 address of the ATM node

A2EA2 = E164 address of the IP node

BIDD1 = Session Identifier communicated in RANAP(Binding ID)

194.237.226.242 = IP address of the IWF

iwf1.operator.net = domain name of the IWF

Iputrannode2.operator.net = domain name of the IP R5 node

### 6.10.5.2 Bearer Control proposal using a new protocol ("Q.IP-ALCAP"), optimised for concatenation with AAL Type 2 links

The discussion of the TNL interworking functionality in clauses 6.10.2.2 and 6.10.4 shows that a transport network layer interworking functionality (TNL IWU) is needed as well as a signalling protocol for bearer control (IP-ALCAP).

A standardized transport network control protocol is beneficial to operators that have multi-vendor environments and one interworking function may be used by several RNCs, although they are from different vendors.

Also from the discussion in 6.10.2.2 and 6.10.4, it becomes clear that the interworking functionality is part of the TNL. According to the principles of 3GPP and in particular RAN WG3, specification of new TNL protocols should preferably be done within other groups, e.g. IETF or ITU-T.

As depicted in figures 6-36 and 6-37, the TNL IWU uses Q.2630.2 for communication with the R99/Rel-4 UTRAN nodes. In order to ease implementation of such TNL IWU, the bearer control protocol for the IP-part of the connection will be as close to Q.2630.2 as possible. Related activities were started in ITU-T/SG11 as ITU-T was found to be the suited organisation to specify this new bearer control protocol.

Currently (March 2002), ITU-T has started to investigate the requirements for such protocol. As no name for the new protocol has been defined in ITU-T yet, we will use the term "Q.IP-ALCAP" in this section to refer to this approach.

From perspective mentioned above, it is desirable that "Q.IP-ALCAP" fulfils the following requirements:

- Highly consistent with Q.2630.2 due to implementation related reasons described above
- Support of embedded E.164 addresses or AESA variant of NSAP also for IP nodes (To allow IP nodes to address R99/Rel-4 ATM nodes)
- Support of the generic IP-QoS parameters as agreed in section 7.9 for solution (3), i.e. Bit rate, SDU size, TNL QoS Class

The following subsections of 6.10.5.2 will give details on the "Q.IP-ALCAP" proposal. As ITU-T is working in parallel to 3GPP TSG RAN WG3, additional information can be found in their documentation (the topic is handled in ITU-T SG11, Question 15).

Regarding the schedule of the work in ITU-T and 3GPP, it may be desirable to hold intermediate versions of “Q.IP-ALCAP” in 3GPP, until the final version of this protocol is approved by ITU-T SG11. Details how to handle such intermediate specification are to be determined.

6.10.5.2.1 Overall Scenario for “Q.IP-ALCAP”

The following figure 6-41a gives an overview on the application of “Q.IP-ALCAP” in IP/AAL2 interworking. It shows the user plane of an “A2IP connection” which is the concatenation of AAL2 type links (“AAL2 link” in figure 6-41a) with an IP link (“A2IP link” in figure 6-41a). Figure 6-41a is exactly the scenario as depicted in TRQ.AAL2IP.iw [67] which was (according to [68]) accepted as a baseline text specifying requirements by ITU-T.

In this scenario, “Q.IP-ALCAP” shall support the establishment, maintenance, modification, and clearing of IP links as part of a concatenation of AAL type 2 links with an IP link in a mixed AAL type 2 and IP environment. The IP part of such a concatenated link is denoted in the figure as "A2IP link". The shaded area of figure 6-41a thus also shows the scope of TRQ.AAL2IP.iw [67].

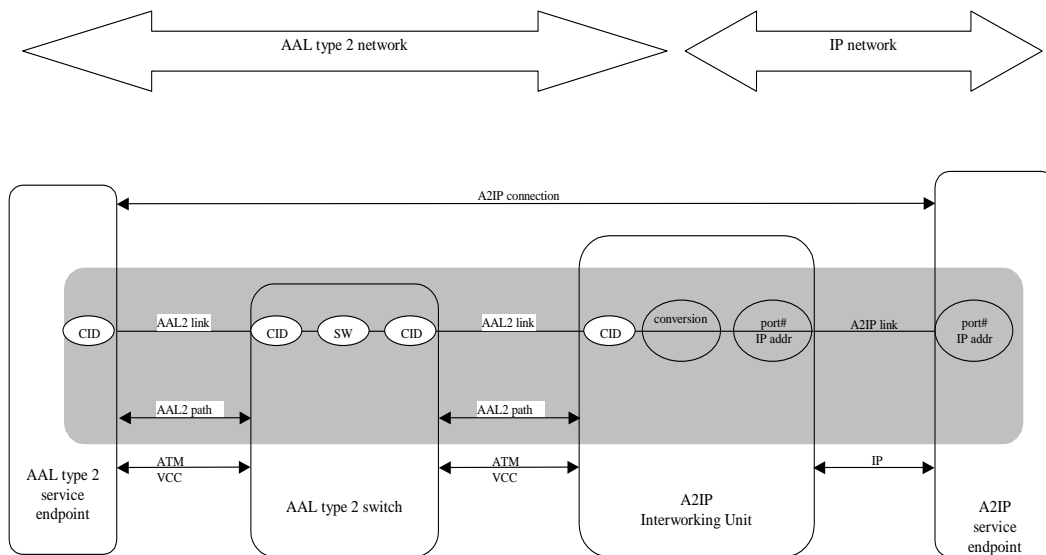
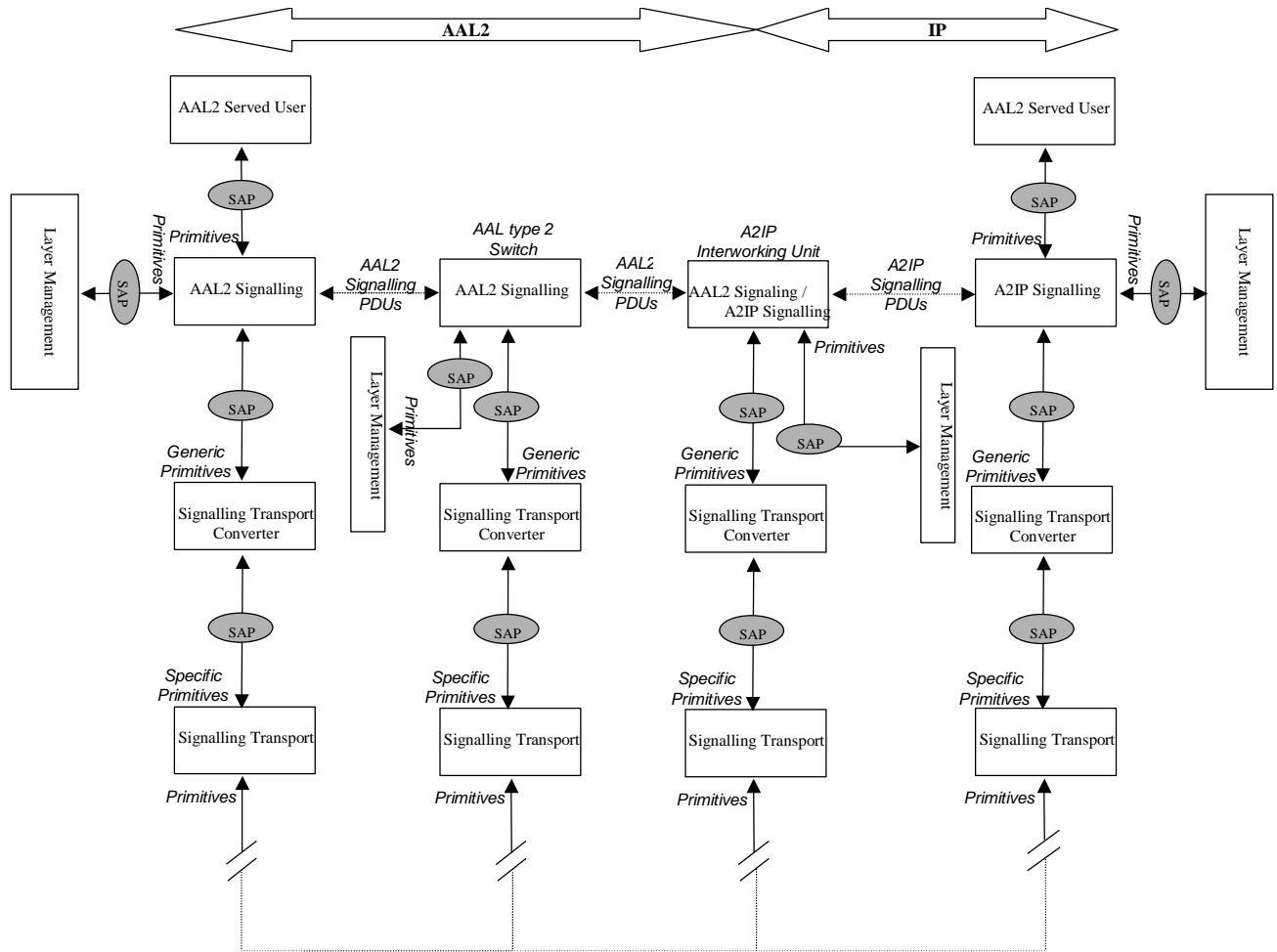

Figure 6-41a: Scope of TRQ.AAL2IP.iw [67]

Figure 6-41b gives additional details of the layering of the signalling protocols and visualises again the positions of served users in this scenario. The “A2IP Signalling” entities in figure 6-41b denote the signalling endpoints for the “Q.IP-ALCAP”. Note, that in the course of work on “Q.IP-ALCAP” the scope of an “AAL2 Served User” has been extended in a way that it can be the user of an AAL2 type signalling protocol or A2IP type signalling protocol. The primitives exchanged between an “AAL2 Served User” and an “A2IP signalling” entity will differ from the primitives described in Q.2630.

Note: A draft Q.IP-ALCAP was provided for information in [69].



**Figure 6-41b: Detailed Layering of Signalling for AAL2/IP Interworking**

The definitions corresponding to terms used in figures 6-41a and 6-41b are:

**A2IP connection:** The logical concatenation of one or more AAL type 2 links and A2IP links between an AAL type 2 service endpoint and an A2IP service endpoint. From the perspective of a Q.2630.1 and Q.2630.2 AAL type 2 service endpoint, an A2IP connection is seen as an AAL type 2 connection.

**A2IP link:** The logical user plane communication facility between two A2IP nodes. An A2IP link is designated by a pair of IP address/port number combinations.

**A2IP node:** An A2IP service endpoint or an A2IP Interworking Unit.

**A2IP interworking function:** Functions residing in a A2IP interworking unit providing the bridge between an AAL type 2 signalling entity and an A2IP signalling entity.

**A2IP Interworking Unit:** Interworking unit providing the conversion from AAL type 2 bearer to IP bearer (RTP[59]/UDP[42] or UDP[42] only). The Interworking Unit terminates AAL type 2 links and A2IP links. There is no served user associated with an A2IP Interworking Unit. From UTRAN perspective, this unit is the Release 5 TNL Interworking Unit.

**A2IP service endpoint:** A termination point of the IP part of an A2IP connection. There is an AAL type 2 served user associated with an A2IP service endpoint.

**AAL type 2 served user:** The user of an AAL type 2 or A2IP signalling protocol.

**A2IP signalling protocol:** Control plane functions for establishing and releasing A2IP connections and the maintenance functions associated with the A2IP signalling.

6.10.5.2.2 Protocol Stack for “Q.IP-ALCAP”

**Protocol Stack**

As interworking between IP and ATM based RNCs appears only during the migration phase from an ATM based network to an IP based one and only at the boarder between the two network types, the interworking solution – and therefore the selected signalling protocol stack – should be straight-forward.

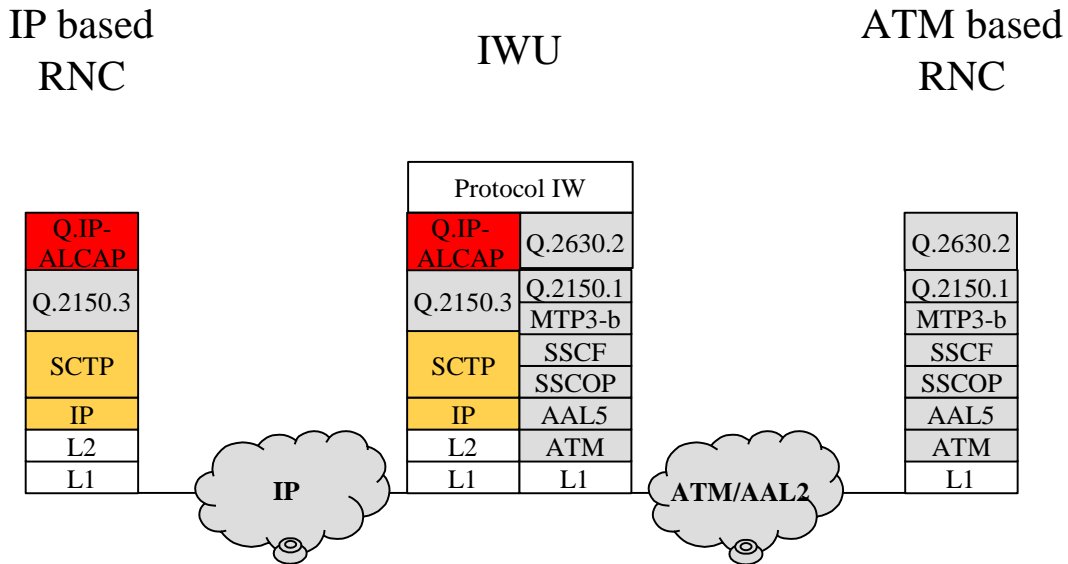

**Figure 6-42: Protocol Stack for Transport Network Control Plane Interworking**

Figure 6-42 presents the proposed protocol stack within the transport network control plane. The Signalling Transport Converter on SCTP is defined in [53].

**Benefits of this Protocol Stack**

The benefit of that protocol stack is, that most employed protocols are already in use inside the RAN and the additional specification work is low. Therefore a standardized interworking functionality can be easily introduced into the RAN without the necessity of new protocols. Services provided by AAL2 signalling entities are unchanged. The interworking unit itself can be based on an existing set of AAL type 2 service endpoints.

6.10.5.2.3 Example: Connection Establishment on Iur

This example shows transport bearer establishment and data on Iur. This shows the case where the legacy RAN is the drift RNS.

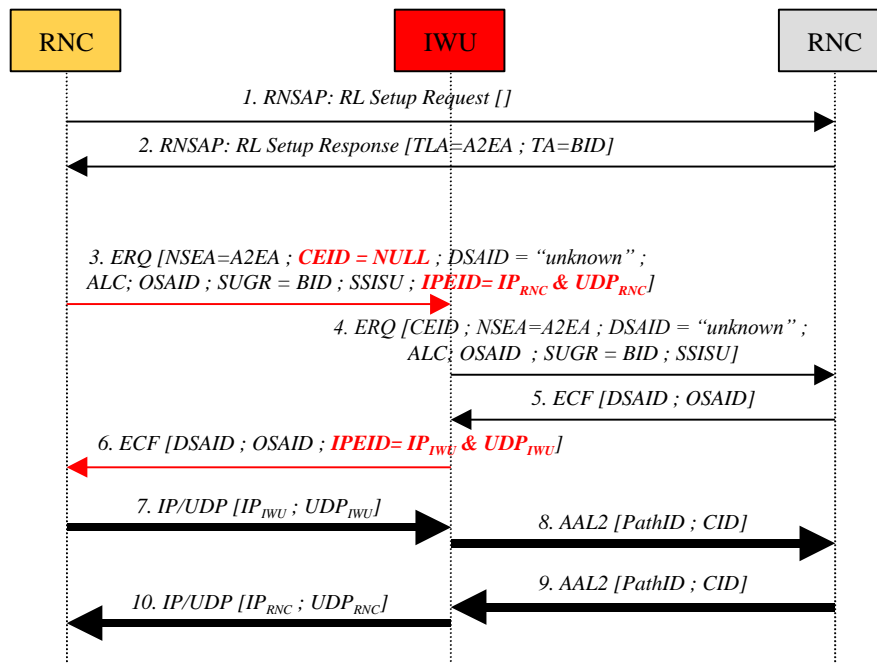

**Figure 6-43: Connection Establishment on Iur**

- 1) IP based RNC (serving RNS) initiates establishment of the radio link with RNSAP message Radio Link Setup Request.
- 2) The legacy RNC node sends RNSAP message Radio Link Setup Response to the IP based RNC containing TLA and TA. TLA contains the ATM endpoint identifier of the ATM based RNC and TA contains an binding ID chosen form the ATM based RNC.
- 3) The IP based RNC sends an Q.IP-ALCAP establishment request message (ERQ) to the IWU that contains the IP endpoint identifier (IP address and UDP port of the IP based RNC for the new link). The CEID will be set to NULL.
- 4) The IWU acts as an AAL type 2 switch, but in addition it removes the IPEID and generates the CEID.
- 5) The CN node sends the connection confirm message (ECF) to the IWU.
- 6) The IWU acts as an AAL type 2 switch, but in addition it IPEID containing IP address and UDP port of the IWU for the new connection.
- 7) The IP based RNC sends data to the IWU using the assigned IP address and UDP port.
- 8) The IWU passes the data on to the ATM based RNC node using the established AAL2 connection.
- 9) The ATM based RNC node sends data to the IWU using the established AAL2 connection.
- 10) The IWU passes the data on to the IP based RNC using the assigned IP address and UDP port of the RNC.

Connection release is simply the same as specified in [52]. Connection establishment initiated by the ATM based RNC works respectively.

### 6.10.5.3 IP-ALCAP based on Q.2630

#### 6.10.5.3.1 Benefits

AAL2 signalling Q.2630 is used as the ALCAP in Re199, Re14 and Re15 ATM UTRAN nodes. So Q.2630 will be in Re15 UTRAN irrespective of its presence in the Re15 IP transport option. Q.2630 itself is expected to be a well-known protocol (behaviour, performance, operation&management) by the time it is introduced in any Re15 IP UTRAN.

IP-ALCAP as a whole is introduced in Re15 IP transport option only as the control protocol between the IP UTRAN node and the stand-alone ATM/IP interworking unit. In the case where no interworking is required, i.e., there are only



Rel5 IP nodes and no IP/ATM interworking unit, then the IP-ALCAP is not required either. Thus the presence of IP-ALCAP is tightly coupled to the presence of ATM transport between the two UTRAN nodes.

It is explained in this contribution that the needed change to the Q.2630 for it to provide the IP-ALCAP functionality is small and specific to its application as the control protocol in the Rel5 IP TNL-IWU interface. Thus this change can well be specified by the involved 3GPP Working Group alone, without any need for any involvement of any 3GPP external standards organization. This aspect is attractive in the sense that it excludes all additional risk in schedule/availability of the needed capability.

During the discussions in RAN WG3 it has been argued that any new protocol that is introduced in Rel5 IP transport should be an IETF protocol. However, the introduction of Q.2630 as the IP-ALCAP is to use an existing and well-established UTRAN protocol (also used in CN) instead of introducing any new protocol at all.

### 6.10.5.3.2 IP-specific information in Q.2630 in Served User Transport (SUT) parameter

All information that is conveyed in the control plane of the Rel5 IP TNL-IWU interface is only between the peer termination points of the given interface. This is because of the following:

- 1) IP-ALCAP in Rel5 is introduced only as the control protocol between the Rel5 UTRAN IP node and its corresponding stand-alone Interworking Unit (the 3<sup>rd</sup> interworking alternative).
- 2) In this interface there are no intermediate AAL2 switches nor any other intermediate IP-ALCAP-aware nodes.
- 3) IP-ALCAP is not visible to the other side of the TNL-IWU, including any intermediate AAL2 switch there.

The following figure depicts the scope and visibility of IP-ALCAP in Rel5 UTRAN.

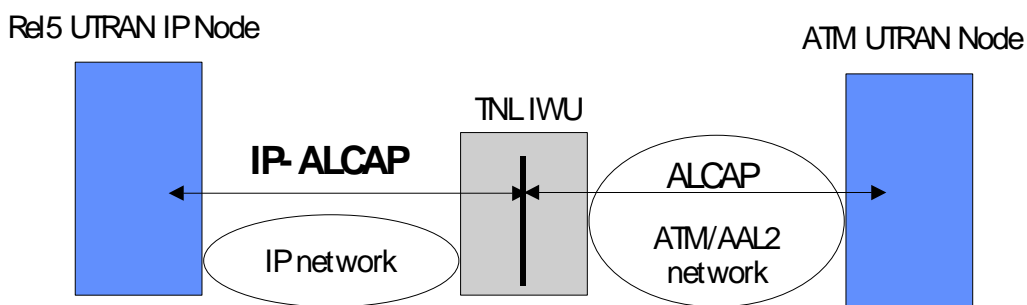

Figure 6-44: IP-ALCAP in Rel5 UTRAN: The scope

#### 6.10.5.3.2.1 Served User Transport parameter in Q.2630

In Q.2630 [2] there is already today a parameter called Served User Transport (SUT). As defined in Q.2630, the SUT is a parameter "with significance to the served user only, therefore they shall not be examined by the nodal function [intermediate AAL2 switch]." Moreover, the SUT "carries the served user data that is transported unmodified to the destination served user." The definition of SUT is similar in both existing Capability Sets, CS-1 and CS-2 of Q.2630 and there is no reason foreseen for it to be excluded from the future Capability Sets (if any) either.

The SUT parameter is very similar to the Served User Generated Reference parameter (SUGR), the major exception being that the SUT has variable length of up to 254 octets. The SUGR is used in Rel99/Rel14/Rel5 for the conveyance of the Binding ID between the two peer UTRAN nodes, in a similar fashion as it is now proposed for the IP related parameters to be conveyed in SUT.

The IP "bearer" establishment procedure between the Rel5 IP UTRAN node and the stand-alone IWU requires a two-way signalling message exchange (Request-Confirm). It is also required (preferable) that each end point can allocate the "bearer" termination point in its side. That is, both endpoints should be able to signal their IP address and UDP port to the other end point. This approach is in line with the principle adopted already in Rel99/Rel14 Iu-PS interface. In the current Q.2630 the SUT has been defined only in the Establish Request (ERQ) message. That is, SUT is available only in the forward direction. Application of SUT in IP-ALCAP requires that the parameter is present also in Establish Confirm (ECF) message. The addition of SUT in ECF can be considered a 3GPP specific change and there an application specific change as it is needed only in the IP TNL-IWU interface. As the SUT as a parameter has already been fully defined in Q.2630 (parameter ID, compatibility rules, etc.), its inclusion in ECF is simply a copy from ERQ. As there are no intermediate AAL2 nodes between the Rel5 IP node and the TNL-IWU, its inclusion in ECF does not

generate any incompatibility issue either (in Q.2630 there is an inbuilt mechanism to cope with these issues, ref. below).

6.10.5.3.2.2 Structure of information

Below is the parameter format used in Q.2630 for all parameters. Parameter ID for Served User Transport is "00001000". Parameter compatibility is used for defining the behavior of the node when unrecognized information is received [table 7-20/Q.2630.1].

**Table 7-2/Q.2630.1 – AAL type 2 parameter format**

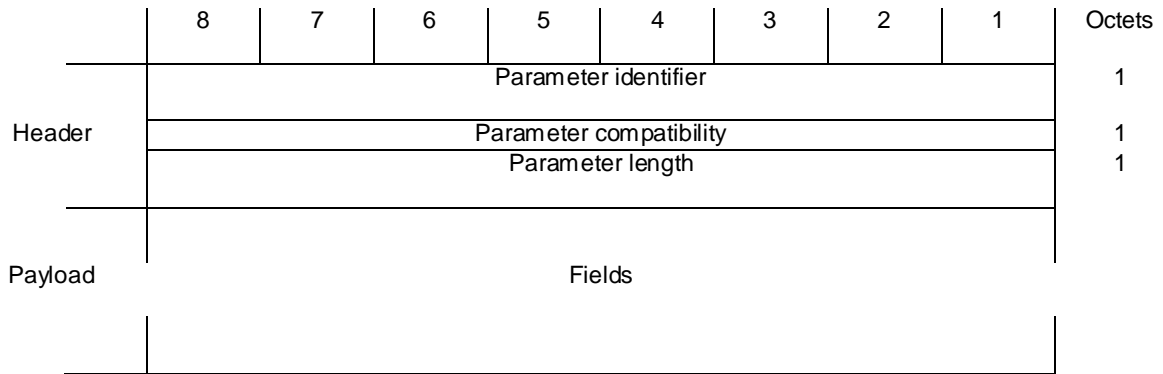

**Table 7-7/Q.2630.1 – Identifiers of the AAL type 2 message parameters (concluded)**

AAL type 2 parameter	Reference	Acronym	Identifier
Served user transport	7.3.8	SUT	00001000

**Table 7-15/Q.2630.1 – Sequence of fields in the served user transport parameter**

Field No.	Field	Reference
1	Served user transport	7.4.18

In the following there is the structure of the Served User Transport field as defined in Q.2630 [chapter 7.4.18].

**Table 7-38/Q.2630.1 – Structure of the Served User Transport field**

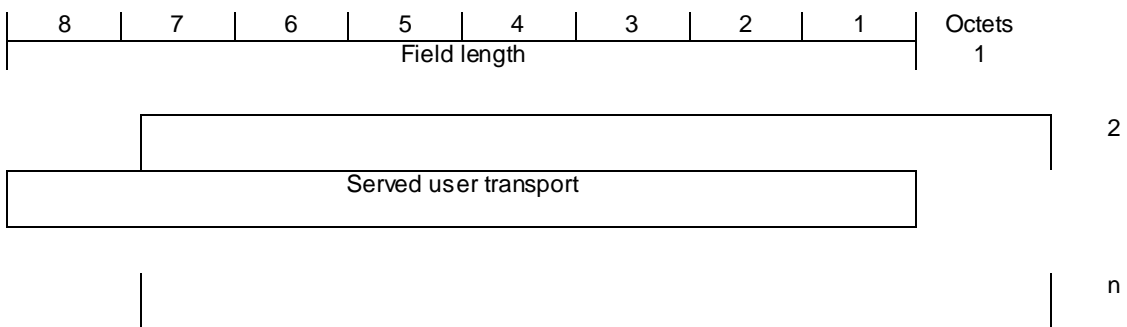

The length of the Served User Transport parameter is variable from 1 to 254 octets, allowing a reasonable capacity for any information exchange.

It has already been agreed that a bearer in IP domain is identified by its UDP ports and IP addresses. Thus the information conveyed in SUT is, at least, the IP address and the UDP port of the originating node (the originator of the corresponding IP-ALCAP message). The structures of the corresponding fields are proposed to be as follows.

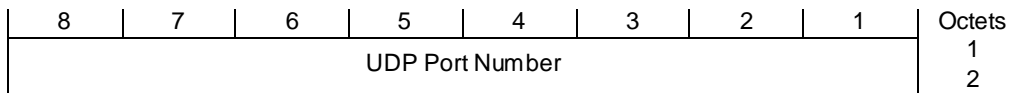

The UDP port Number has a fixed length of 2 octets:

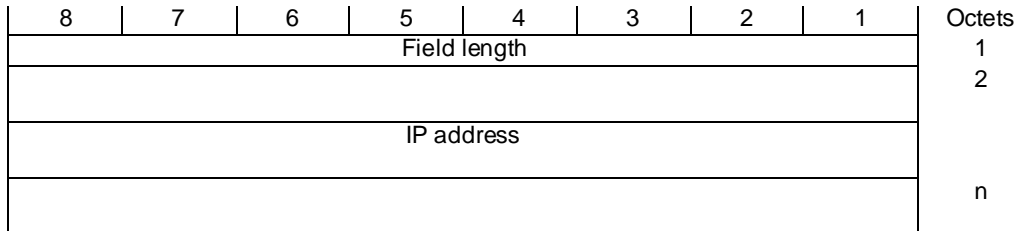

The IP address has a variable length of max. 16 octets (IPv6). Variable length allows the field to be used with IPv4 addresses as well (optional in Re15 IP UTRAN).

The traffic and QoS parameters can be conveyed in the following fields in the payload of SUT.

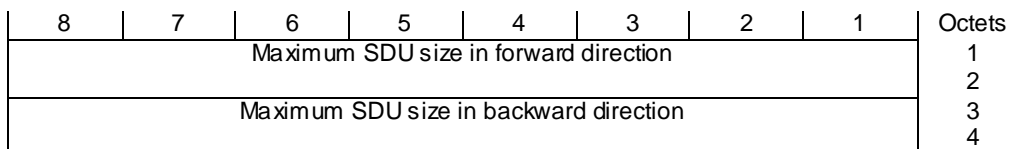
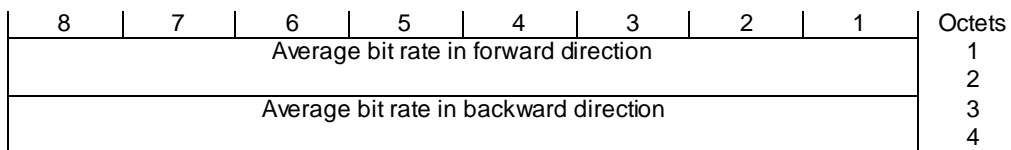
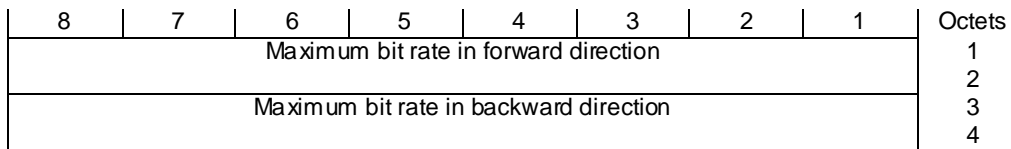
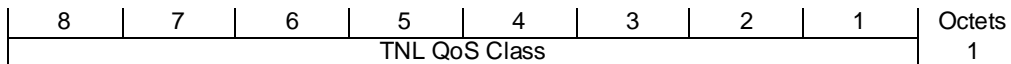

8	7	6	5	4	3	2	1	Octets
Average SDU size in forward direction								1
Average SDU size in backward direction								2
Average SDU size in backward direction								3
Average SDU size in backward direction								4

The coding of the other existing parameters in ERQ and ECF should be kept as it has been defined in Q.2630. Only this way there is no other change needed than the introduction of SUT in Establish Confirm message. It is to be noted here that the AAL2 Service Endpoint Address (A2EA) parameter conveys now the address of the destination ATM UTRAN node that was given in the corresponding xxxAP message. As the signalling bearer of IP-ALCAP is IP based, the IP address of the TNL-IWU is conveyed in the IP header instead of in IP-ALCAP itself. Those parameters that are not applicable in Rel5 IP TNL-IWU interface should be left out if their presence is optional or otherwise filled with a dummy value.

In principle there are two ways of conveying the above defined information in the Served User Transport parameter. Either each element of information has its own identifier or the elements do not have any identifier but only length and value. In this proposal the elements of information do not have any identifiers and the length is included only in case of variable length element (IP address). This approach requires that the order of appearance of the elements is specified as well. With this arrangement the above mentioned elements take 35 octets from the available 252 octets of payload. Should there be any other IP TNL-IWU specific information that needs to be conveyed between the two nodes, this information can be conveyed in the similar fashion as above.

#### 6.10.5.4 Use of IETF RSVP for ATM/IP interworking

This approach consist on the use of the Resource Reservation Protocol (RSVP) as the IP TNL control plane that allows:

- 1) The signalling of the QoS parameters to the IWU (IP originated case)
- 2) The application of the QoS signalled by Q.2630 (ATM Originated case)
- 3) The simplification of the IWU. This would be reduced to an IWF integrated in a typical IP router, less expensive to operators and easier to provide by vendors and also making the UTRAN transport more standard to the classical IP transport, since RSVP is commonly implemented in the IP routers.

RSVP [54] is a protocol designed for integrated services in Internet allowing the establishment of simplex IP sessions for many different types of applications (it handles different flows with different QoS). The advantages of this protocol is that a limited number of messages are needed to define the behavior that is explained in the present document, together with the QoS orientation of RSVP. It also allows defining new objects where, in this case, the needed ATM parameters will be transferred to the IWU in order to be able to establish ATM connections.

As basic operation, the TNL-IWU will receive either Q.2630 establishment requests or RSVP Path messages and be able to generate the appropriate messages on the other side with the information included in the received messages. Therefore, RSVP signalling is only valid between IP UTRAN node and IWU, and ATM signalling is valid between ATM UTRAN node and IWU.

##### 6.10.5.4.1 Working scenarios

This clause covers the main scenarios including establishment and release of transport connections, including the issues derived from this kind of implementation.

###### 6.10.5.4.1.1 ATM UTRAN Node initiated RL Setup procedure

In this scenario an ATM SRNC (CRNC) sends a RL Setup Request message to an IP DRNC (Node B), which sends back a RL Setup Response message including SUGR (binding ID) and A2EA (Transport Layer Address) IWU among other parameters.

The TNL messages are depicted in the figure below:

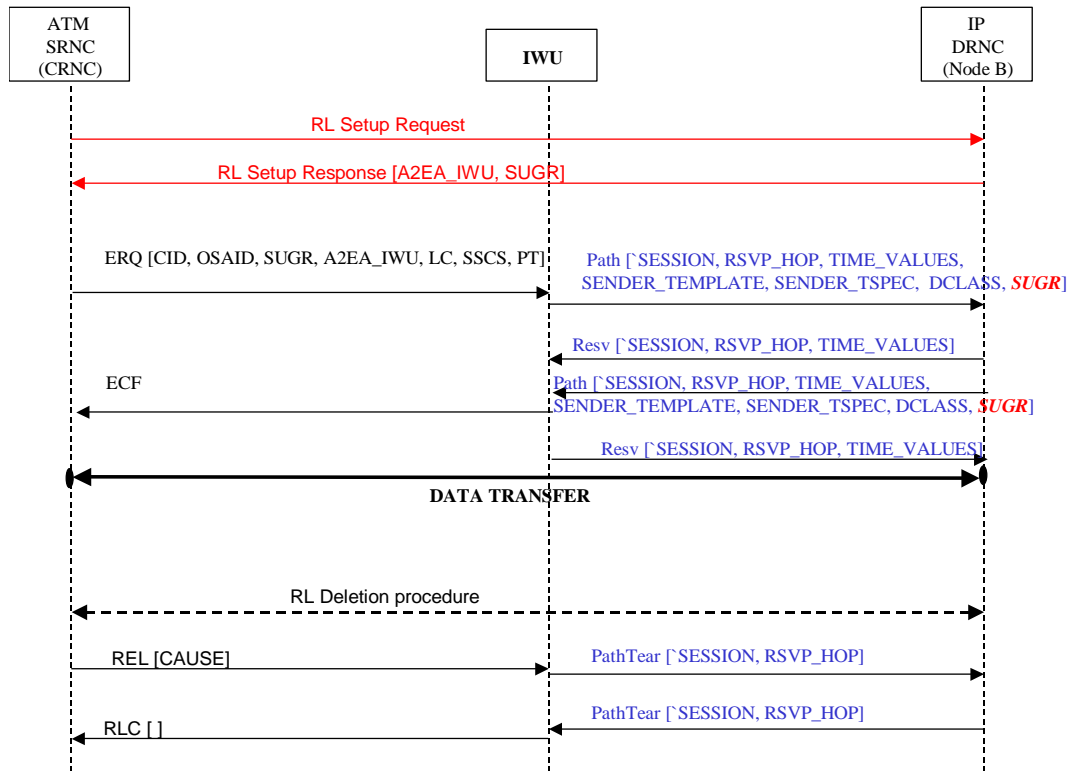

**Figure 6-45: Interaction between ATM SRNC (CRNC) and IP DRNC (Node B)**

Procedure:

- 1) Radio Link Setup procedure. In addition to the SUGR, PT (only in R5) and SSCS Information, the IP node sends the Transport Layer Address of the IWU in the RADIO LINK SETUP RESPONSE message.
- 2) After RL Setup procedure is completed, SRNC (CRNC) sends an ERQ message to the IWU.
- 3) Upon reception of ERQ message and after granting the admission of the new AAL2 connection, the IWU sends a PATH message to the DRNC (Node B) with the help of a table to convert ATM ports to IP addresses. This message will include the QoS parameters needed for the Admission control (SENDER\_TEMPLATE, SENDER\_TSPEC, DCLASS and SUGR), and additionally it may provide the DiffServ code points to use for the bearer flow (with the inclusion of the DCLASS object in the Path message).
- 4) Upon reception of a Path message the DRNC (Node B) sends a RESV and a PATH messages to the IWU if no other session with the requested Binding-ID (SUGR) is set (note that a reservation is needed for each direction as well as a previous definition of the connection QoS by means of the PATH message). If any of these messages fail, a timer waiting for an incoming Path message in the IWU or the PathErr and ResvErr messages incoming to the IWU will make that SRNC (CRNC) and IWU consider the ERQ as failed. Also note that there is a need for a RNC\_ID to A2EA\_IWU conversion in the DRNC database.
- 5) Upon reception of the Path message, the IWU sends an ECF message to the SRNC (CRNC) and a Resv message to the DRNC (Node B).
- 6) At this point data can be sent in both directions. Note that the RSVP PATH and RESV must be maintained periodically.
- 7) The SRNC (CRNC) initiates the release of the transport connections with a REL message to the IWU.
- 8) Upon reception of a Q.2630 Release Req message the IWU sends back the confirmation (RLC) to the SRNC (CRNC). It is up to the implementation whether the RSVP is released by means of a PathTear message or waiting for the refresh timer's expiry. However, it is recommended to implement the Tear down messages, to speed up the release of the IP bearer.

## 6.10.5.4.1.2 IP UTRAN Node initiated RL Setup procedure

In this scenario an IP SRNC (CRNC) sends a RL Setup Request message to an ATM DRNC (Node B), which sends back a RL Setup Response message including SUGR and A2EA IWU among other parameters.

The TNL messages are depicted in the figure below:

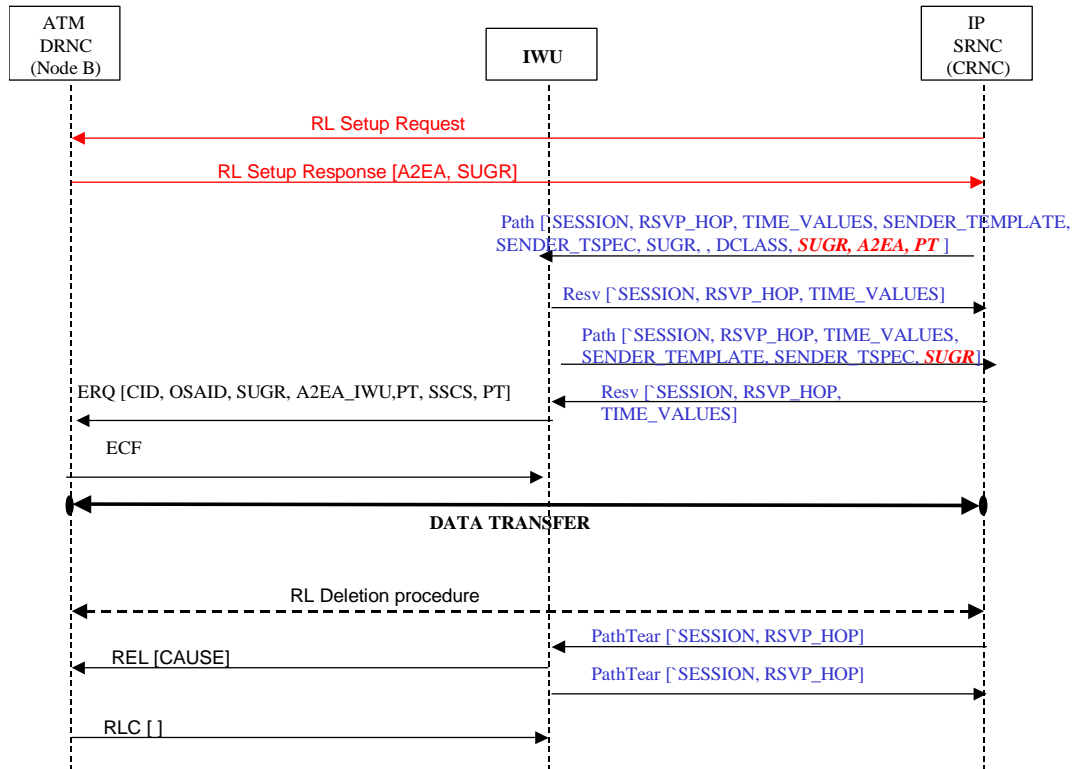

**Figure 6-46: Interaction between IP SRNC (CRNC) and ATM DRNC (Node B)**

Procedure:

- 1) After RL Setup procedure is completed, SRNC (CRNC) sends a Path message to the IWU. This message will contain additionally to the RSVP PATH parameters, the DCLASS object, the SUGR, A2EA and PT information in a new RSVP Object.
- 2) Upon reception of a Path message the IWU will respond with a Resv and a Path messages.
- 3) Upon reception of a Path message the SRNC (CRNC) will send a Resv message to the IWU.
- 4) Upon reception of a Resv message, the IWU will send an ERQ message to the DRNC (Node B).
- 5) The DRNC (Node B) will respond with an ECF message to the IWU, completing the establishment.
- 6) In this point data can be sent in both directions. Note that the RSVP Path and reservations must be maintained periodically.
- 7) The SRNC (CRNC) initiate the transport layer connections by sending a PathTear message to the IWU.
- 8) Upon reception of a PathTear message the IWU will send a REL message to the DRNC (Node B) to release ATM connection.
- 9) The DRNC (Node B) will send back a confirmation message to the IWU (RLC), completing the ATM connection release.
- 10) The IWU also sends a PathTear message to the SRNC (CRNC) in response to the previously received PathTear message.

## Advantages:

- There is a direct signalling and application of the same QoS across the entire interface. This is possible because of the interworking function integrated in RSVP as well as the possibility to signal DiffServ Code Point inside RSVP.
- There is no limitation on the IP side respective to the method of QoS to be applied, it is possible to use either RSVP or DiffServ.

## Issues:

- The IWU will have only one node associated to an ATM address + OSAID. This is to uniquely identify the IWU Transport Layer Address with an IP node.
- In the DRNC (Node B) side there is a need for an RNC-ID to A2EA\_IWU database to perform the addresses conversion. The IWU ATM address is a "default gateway" for the IP node to address all the ATM nodes.
- In the IWU side there is a need for an A2EA\_IWU + OSAID to IP address database to perform the addresses conversion.
- There is a need to define a new object in RSVP that carries all AAL2/ATM QoS related fields needed in the procedure.
- In case diffserv is used, the Path ID will be mapped to a DiffServ CP and the IWU will contain a table to map PT to diffserv CP. Here the DCLASS object will be used.
- The IWU will have a timer that controls the PATH refresh procedure in order to release the ATM connection if any problem occurs in the IP side.

#### 6.10.5.4.1.3 RSVP considerations

In this clause generic topics regarding RSVP such as Reservation Confirmation, traffic policing, recommended values for timers or security considerations are not covered. For more information about them please refer to [54].

The only modification in the RSVP protocol needed to make this solution feasible is the definition of a new object apart from the standardized ones (SESSION, RSVP\_HOP, TIME\_VALUES, etc.) assigning an unused value for an object that will contain the ATM parameters needed to be passed to the IWU in order for it to establish the corresponding ATM connections towards the ATM UTRAN node.

This new object must be defined according to the standard object format defined in [54]. Every object consists of one or more 32-bit words with one fixed header with the object length, the chosen Class-num and C-Type (a value unique within Class-num). After the header the content should be defined included the needed ATM parameters.

#### 6.10.5.5 Inter-working with a PWE3-Capable ATM Switch

The signalling flow for the ATM-IP interworking solution based on a PWE-capable ATM switch as defined in section 6.10.2.1.1 is presented in this section.

##### Protocol Stack

As interworking between IP and ATM based RNCs appears only during the migration phase from an ATM based network to an IP based network and only at the border between the two network types, the interworking solution – and therefore the selected signalling protocol stack – should be straight-forward and not entail new development effort.

The reuse of Q2630 meets this straightforward consideration as it is simply needed to define a new layer-1 to reuse this existing TNL CP protocol on the IP part. The overview of the protocol stacks used is presented hereafter with the new part in red.

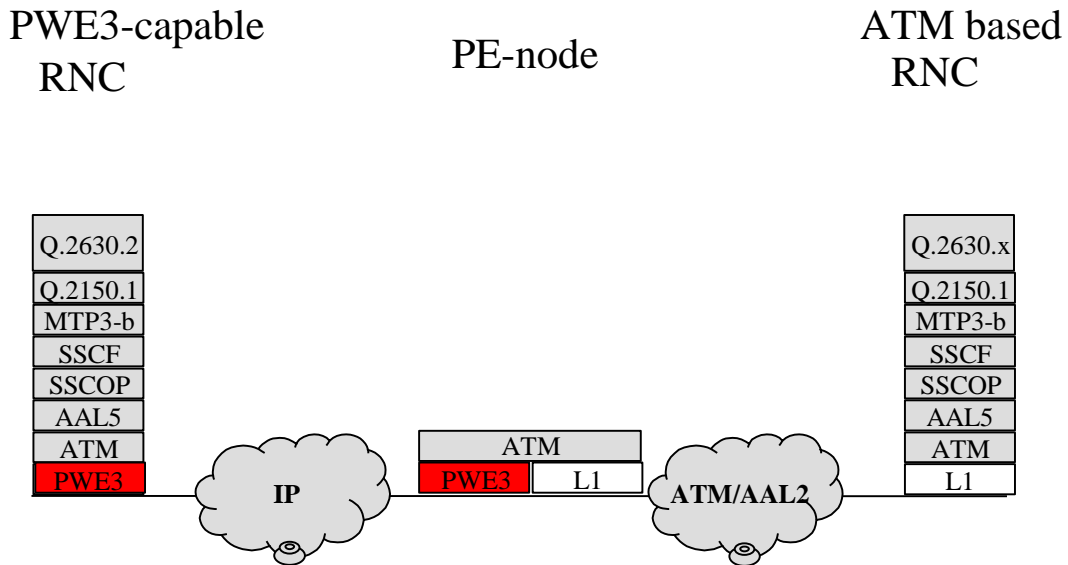

Figure 6-46a: Protocol Stack for Transport Network Control Plane Interworking

**Benefits of this Protocol Stack**

The benefit of that protocol stack is, that most employed protocols are already in use inside the RAN and the additional specification work is low. Therefore a standardized interworking functionality can be easily introduced into the RAN with only the necessity of a new PWE3 tunnelling layer. Services provided by AAL2 signalling entities are unchanged. The interworking unit is straightforward as it is an ATM switch equipped with a specific layer-1 and transparent to the signalling flows. Minimum operation effort is needed to operate and maintain this ATM switch.

**Example: Connection Establishment on lur**

This example shows transport bearer establishment and data on lur. This shows the case where the legacy RAN is the drift RNS.

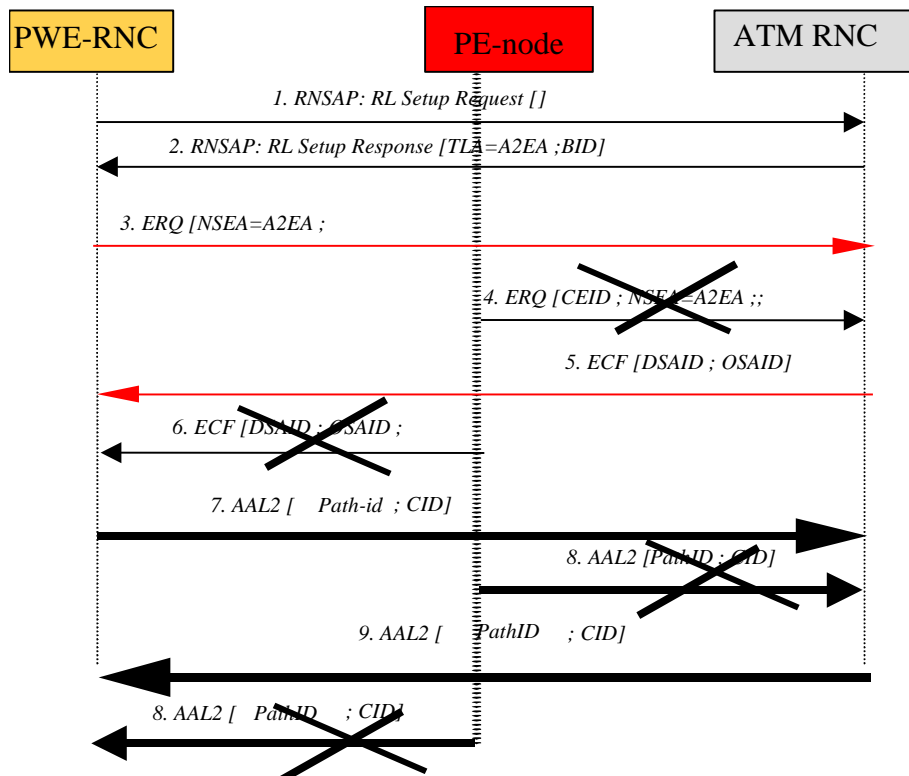



**Figure 6-46b: Connection Establishment on Iur**

- 1) The PWE3- RNC (serving RNS) initiates establishment of the radio link with RNSAP message Radio Link Setup Request.
- 2) The legacy RNC node sends RNSAP message Radio Link Setup Response to the IP based RNC containing TLA and a binding ID. TLA contains the ATM endpoint identifier of the ATM based RNC.
- 3) The PWE3-RNC selects a signalling Vp/Vc according to the received AESA address and sends a Q2630 establishment request message (ERQ) tunnelled over PWE3. The ERQ message contains the Path-id to be used for the user plane.
- 4) The PE-node is **transparent** for the ERQ message and may simply switch the Vp/Vc (act as an ATM switch) towards the next ATM switch or next aal2 switch or terminating UTRAN node. Step 4 is starighforward.
- 5) The legacy RNC node sends the connection confirm message (ECF) in reply.
- 6) The PE-node is **transparent** for the ECF message and may simply switch the Vp/Vc (act as an ATM switch) towards the next ATM switch or next aal2 switch or originating UTRAN node. Step 6 is starighforward.
- 7) The PWE3- RNC sends data to the legacy RNC node which is also **transparently** carried over the PWE3-tunnel.
- 8) Only switching at ATM level if needed.
- 9) The ATM based RNC node sends data to the PWE3 RNC which is also **transparently** carried over the PWE3-tunnel.

Connection release is simply the same as specified in [52]. Connection establishment initiated by the ATM based RNC works respectively.

This sequence flow shows that this solution is the same as currently used but simply provides an adaptation of layer 1.

## 6.10.6 Coexistence between Rel.5 and R99/R4 Iur Control Plane using SUA protocol

Clause 6.7.2 describes the option of SUA as IP based signalling User Adaptation Layer in Iur Control Plane.

It is clear that SUA provides seamless functions and services as SCCP (from RNSAP point of view), and also, as advantage, SUA is optimized to be used over SCTP/IP, providing e.g. SCCP-to-SCTP/IP address translation. See [26] for further details.

### 6.10.6.1 Connecting an Rel.5 RNC to a R99/R4 RNC

A way to interwork an Rel.5 RNC to a R99/R4 RNC is using signalling gateway. (this gateway can be embedded in the same physical equipment as an RNC) Using SUA, the RNSAP SAP is maintained for both TNL options since SCCP and SUA provide the same primitives and services to RNSAP, so no changes to RNSAP are needed to support both TNL options. With SUA, the RNL independence is maintained for Rel.5 as in R99/R4.

The signalling gateway would perform the L2/L1 to AAL5/ATM/L1 conversion. In this case SUA does not add any interworking problem, since the signalling gateway performs the domain conversion from SCCP to SUA/SCTP/IP and vice versa. Also, it is noted that the signalling gateway could come from any vendor, since all protocol used in both ends of the SG are standardized.

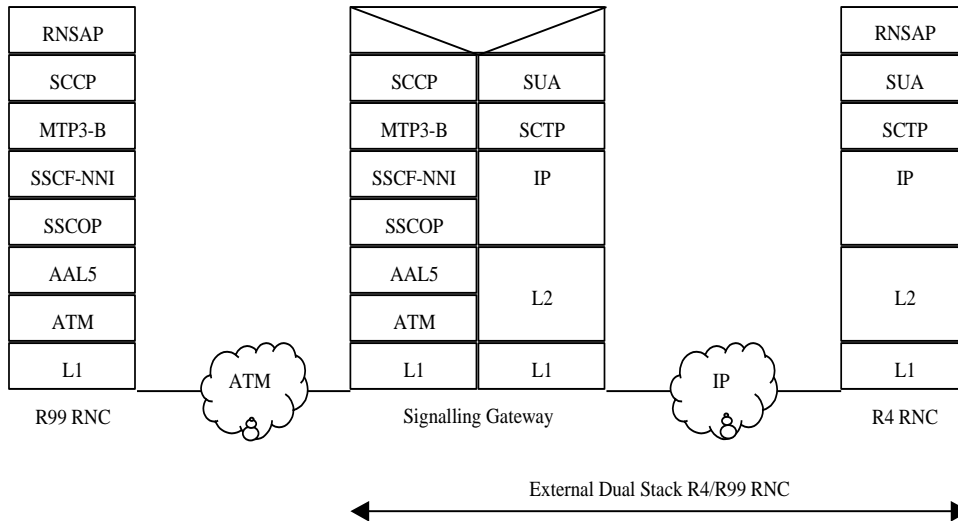

**Figure 6-47: Interworking between External dual stack RNC and a Rel4/R99 RNC**

This option permits the providers and operators to handle the different interworking scenarios in an efficient way, e.g. several Rel.5 RNCs sharing the same signalling gateway to a R99/R4 only RNC through an IP network, or RNCs with embedded signalling gateways connected to R99/R4 only RNCs and using both IP and ATM networks, while maintaining the RNSAP protocol as in R99/R4.

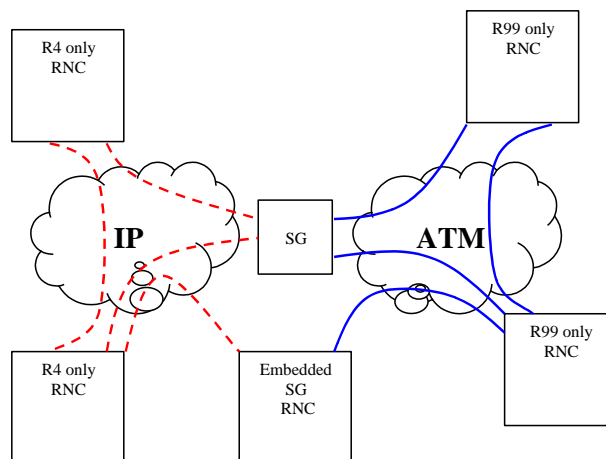

**Figure 6-48: Possible interworking scenarios using SUA**

Summarising the conclusions:

- SUA maintains the same primitives and services as SCCP and is optimized to be used over SCTP/IP, e.g. including the SCCP-to-SCTP/IP address translation.
- There are no interworking problems between Rel.5 and R99/R4 Iur Control Plane when SUA protocol is used below RNSAP for Rel.5 stack.
- With SUA, the Signalling gateway approach also gives flexibility to both providers and operators to implement the interworking between the R99/R4 and Rel.5 releases, depending on transport network characteristics and equipment availability, while maintaining open interfaces (Rel.5 and R99/R4 Iur) in both R99/R4 and Rel.5 RNCs.

## 6.11 Synchronization

Node synchronization requirements for an IP based UTRAN nodes should be investigated including minimizing delay variation and clock frequency differences between an application source and sink.

## 6.12 Security

This study area is related to security aspects.

### 6.12.1 Security Threats

[43] classifies between threats associated to the air interface, to the UE or to other part of the network. For the other part of the network, the identified threats are the following:

- Unauthorized access to data: traffic eavesdropping, receiver masquerading, unauthorized access to stored data, traffic flow analysis.
- Threats to integrity: manipulation of stored data, traffic or network elements by masquerading or any other way.
- Denial of service: physical or protocol intervention, abuse of emergency services.
- Repudiation: of charge, of traffic origin or delivery.
- Unauthorized access to services: by masquerading or misusing privileges or services.

### 6.12.2 Security Operation in IP networks

#### 6.12.2.1 IPsec architectures

In IETF, security is a whole area of work, in which one group focuses especially on security architecture and IPsec protocol suite [44], [45]. IPsec is a protocol providing authentication and integrity protection in two different architectures:

- End-to-end security provisioning between hosts: this solution puts the complexity into the hosts;
- Gateway to gateway: IPsec is terminated in intermediate nodes (routers) that protect the data in a sub-part of the network that may be insecure.

When the security is provided from host to host, two modes are possible:

- Transport mode, in which integrity and authentication cover only transport protocol (above IP) and higher protocols.
- Tunnel mode, in which the IP header is also protected. That mode needs a second IP header to be present to allow routing.
- The tunnel mode is the only possible solution for gateway to gateway architecture.
- Both modes cause additional overhead per IP packet.

IPsec is a separate protocol in IPv4 but is fully integrated in IPv6. However its use is optional in IPv6. It is possible to provide security to IPv6 hosts without using IPsec in the hosts, for instance with gateway to gateway tunnel mode.

IPsec architecture assumes the existence of a Key management system. That system can be manually administered or controlled by IETF protocols like, ISAKMP [45].

#### 6.12.2.2 SCTP Security features

SCTP (Stream Control Transmission Protocol) has been designed to transport signalling and control data on top of IP. It delivers a reliable transport service, like TCP. But it brings also some additional features.

It incorporates a cookie exchange mechanism at association establishment. That procedure was explicitly designed to prevent unauthorized connections to be set up at transport level.

### 6.12.2.3 Firewalls and other systems

Beyond standard protocols and architecture defined by IETF, constructors have proposed their own security features in boxes often called "Firewalls". They most often implement standard security solutions but they also incorporate additional functions.

This kind of equipment is mainly dependent on the State of the Art of any kind of security experts. The decision to use it is out of the scope of UMTS standardization.

## 6.13 Iu-cs/Iu-ps harmonization

This study area is related to the possibility of removing the Iu-cs/Iu-ps distinction in the user plane and in the control plane.

### 6.13.1 GTP-U for Iu user plane

#### 6.13.1.1 Iu PS

With IP transport for UTRAN, GTP-U will be used on the IuPS interface as in Release 99 / Release 4. However, when real-time applications are considered and IP header compression is used, the GTP-U header is relatively large. There are currently 2 possible headers that can be used for GTP-U. One consists of 8 octets, the other 12 octets. In addition, there is the application independent GTP' protocol that is used for 3G and GPRS charging. GTP' uses a smaller header than GTP (6 octets) but has (for individual packets or for a group of packets) acknowledgments also in the user plane, in addition to having acknowledgements for the signalling plane packets. Protocol Type (PT) flag in the bit 5 of the header indicates which of the two headers is being used.

IP header compression allows the IP/UDP headers to be compressed to 2 – 5 octets. If a sequence number is needed with GTP-U, the header size is 12 octets. For example, for a 40-octet payload, the GTP-U overhead alone can be over 20% of the packet size (IP/UDP/GTP/payload) when a sequence number is included.

For real-time applications much of the GTP-U header is not needed. A header definition for GTP-U should be defined that is optimized for real-time applications.

#### 6.13.1.2 Iu CS

GTP-U could be used for the IuCS interface over IP transport for the following reasons:

- The requirements for the real-time IuPS applications and the real-time IuCS applications are the same. It results in the same protocols being used for both IuCS and IuPS (harmonization). GTP-U will be used for the IuPS interface so it will already be available for the IuCS in the Media Gateway.
- It is under the control of 3GPP. Any desired modifications for optimization can be handled by 3GPP.

An alternative to GTP-U is to use RTP: according to RFC 1889, RTP is designed to satisfy the needs of multi-participant multimedia conferences. It therefore provides more functionality than is required and has a large overhead of 12 octets.

The RTP header can be compressed but the decompressor needs to be updated for every packet so it adds processing load over IP/UDP compression alone.

The advantage of RTP is that it is an IETF protocol. However, this protocol will be terminated where the framing protocol is terminated at the UTRAN interface endpoint. It is therefore not important that it is an IETF protocol.

#### 6.13.1.3 GTP header for the Iu-PS user plane

The Release 99 / Release 4 GTP header is shown below.

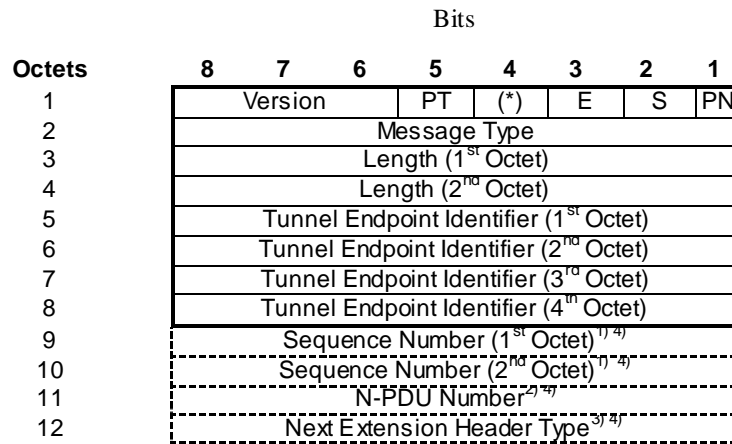

The last two fields would not be necessary to be carried in the lu-PS, so the header size would be 8 (or 10) octets.

NOTE: The GTP-U header is 8 octets unless one or more of the E, S, or PN bits are set, then it is 12 octets.

The (\*) bit is unused:

- Version field: This field is used to determine the version of the GTP protocol.
- Protocol Type (PT): This bit is used as a protocol discriminator between GTP (when PT is '1') and GTP' (when PT is '0'). GTP' is described in the 3GPP TS 32.015, 3GPP 32.215 and in the GSM 12.15.
- Extension Header flag (E): This flag indicates the presence of the Next Extension Header field when it is set to '1'. When it is set to '0', the Next Extension Header field either is not present or, if present, must not be interpreted.
- Sequence number flag (S): This flag indicates the presence of the Sequence Number field when it is set to '1'. When it is set to '0', the Sequence Number field either is not present or, if present, must not be interpreted.
- N-PDU Number flag (PN): This flag indicates the presence of the N-PDU Number field when it is set to '1'. When it is set to '0', the N-PDU Number field either is not present, or, if present, must not be interpreted.

### 6.13.1.4 User plane header simplification considerations for the lu-PS

The following simplifications to the GTP-U header could be considered in order to reduce overhead for real-time applications:

- 1) The length field could be removed. This would mean that the user plane multiplexing could not be done.
- 2) A one-octet message type field is larger than required for GTP-U and is based on GTP-C requirements. There are only a few GTP-U messages. However, for this discussion, it is assumed that GTP-U signalling messages are always sent with a full header. All GTP-U messages use a TEID value of 0.

The following table shows the messages used by GTP-U:

GTP-U Message	TEID
Echo Request	0
Echo Response	0
Error Indication	0
Supported Extension Headers Notification	0

The following text defining the use of the TEID field in the GTP-U header is from the GTP specification, 29.060.

- TEID: contains the Tunnel Endpoint Identifier for the tunnel to which this T-PDU belongs. The TEID shall be used by the receiving entity to find the PDP context, except for the following cases:

- the Echo Request/Response, Supported Extension Headers notification and the Version Not Supported messages, where the Tunnel Endpoint Identifier shall be set to all zeroes;
  - the Error Indication message where the Tunnel Endpoint Identifier shall be set to all zeros.
- 3) The sequence number in GTP might be larger than required for real-time applications.
  - 4) The N-PDU number will never be needed since it is used only for non real-time applications to guarantee that packets are not lost or duplicated during the Routing Area Update procedure and SRNS Relocation.
  - 5) GTP includes a 4 octet Tunnel Endpoint Identifier to identify a flow. This is a larger than required. It is shortened in the below presented alternative header scenarios "A" and "B" to use a 2 octet TEID.
  - 6) Header Extensions do not need to be supported for real-time applications. If extensions are needed for an application, the full GTP header should be used.

**6.13.1.5 Proposed GTP-U-like header scenario "A" for real-time applications**

It is assumed that the TEID/IP address is used to identify a flow (RAB/PDP context). GTP-U signalling messages will use the full GTP header.

The following table shows a proposed GTP-lite header for real-time applications:

<b>Octet</b>	<b>8</b>	<b>7</b>	<b>6</b>	<b>5</b>	<b>4</b>	<b>3</b>	<b>2</b>	<b>1</b>
1	Version		PT0	PT1	*	S	*	
2	TEID (1 <sup>st</sup> Octet)							
3	TEID (2 <sup>nd</sup> Octet)							
4	Sequence Number (1 <sup>st</sup> Octet)							
5	Sequence Number (2 <sup>nd</sup> Octet)							

**Figure 6-49: GTP-lite header in alternative scenario "A"**

- Protocol Type 0, 1 (PT0, PT1): These flags indicate how the header and protocol should be interpreted as shown in the following table. (Only the PT0 exists currently in the 3GPP (and ETSI) GTP and GTP' specifications, with the name Protocol Type, PT.)

PT1	PT0	Meaning
0	0	GTP'
0	1	GTP-full header
1	0	GTP-lite header

- Sequence number flag (S): This flag indicates the presence of the Sequence Number field when it is set to '1'. When it is set to '0', the Sequence Number field is not present.

**6.13.1.6 GTP-U-like alternative header scenario "B" for real-time applications**

Also in the alternative scenario "B" it is assumed that the TEID/IP address is used to identify a flow (RAB/PDP context). GTP-U signalling messages will use also in this scenario the full GTP header.

The above mentioned alternative "A" has several serious limitations which are tried to be improved in this header scenario "B":

- 1) The alternative "A" violates against the current GTP/GTP' protocol identification system standardized in the 3GPP TS 29.060, 3GPP TS 32.015, 3GPP TS 32.215 and against the ETSI GSM 09.60 and ETSI GSM 12.15

what comes to the usage of the bits 4 and 5 of the first header octet. It has been standardized and implemented previously that only the bit 5 of the octet 1 is "visible" and used in a common way in the GTP and GTP' protocols. The tunneled GTP/GTP' packets traveling in a 3G network have several years ago standardized to be identified and even possible to filter from each other by this one bit '5'. Also, the bit '4' is standardized independently in the GTP and GTP' standards and not "visible" to each other of the two protocols. As GTP' standards state: "Bit 5 of octet 1 of the GTP header is the Protocol Type flag and is '0' if the message is GTP'. The Version bits indicate the GTP' protocol version when the Protocol Type flag is '0'." And, the Version bits are understood to mean the GTP or GTP' version, depending on the PT bit being '1' or '0', correspondingly. This Version bits handling would not now work properly if there would be a third protocol header being identified on the bits 5 and 4 of the 1<sup>st</sup> octet.

- 2) Since in the lightweight GTP scenario "A" there is no length information, only one user data packet could be carried at a time by that GTP-lite protocol header alternative. That would mean high relative protocol overhead especially then when the transferred payload packets are small. To avoid the total protocol performance problems resulting from this limitation, this scenario alternative "B" has the normal Length information that the normal GTP (and GTP') also have.

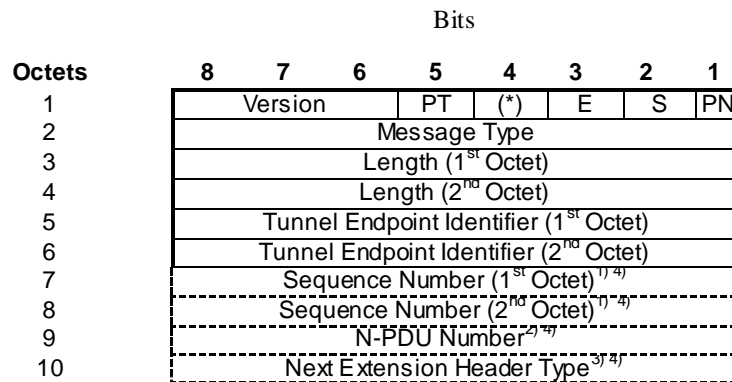

Figure 35: GTP-lite header in alternative scenario "B"

Like in the normal GTP, the two last fields would not be necessary to be carried here in the Iu-PS. So, the header size would be 6 (or 8) octets in the Iu-PS.

In this scenario "B", the already standardized bit 4 and bit 5 usage in GTP and GTP' is not violated. This requires that the identification of this "lightweight GTP header" is done otherwise. This would in practice mean the establishment of a new Message Type to GTP, to form a side variant of the GTP protocol, what comes to the user plane. In this scenario "B" a new Message Type value would be needed to be allocated for the more lightweight GTP-like header, from the GTP Message type table in the 3G TS 29.060. This means that there is no difference in the octet usage in this respect, in relation to the normal GTP.

Thus there would be a properly working and a 3G TS compatible header but the size advantage gained in this scenario "B" would be only 2 octets, in comparison to the normal GTP header.

(Additionally, one octet could maybe be saved if the Sequence Number would be considered necessary to be used and if at the same time one-octet Sequence Numbers would be considered feasible.)

### 6.13.1.7 Comparison of the GTP-U header and the possible new scenarios "A" and "B"

When comparing the GTP, and on the otherhand the lightweight GTP scenarios "A" and "B", the following things can be noted.

Considerations about the alternative scenario "A":

- The lightweight GTP-U alternative "A" seems too limited in capability and incompatible with existing 3G specifications, when compared against the alternative "B" and the normal GTP-U header.

- There is a serious disadvantage in the alternative "A" what comes to the requirement to have maximum stack performance, since the lack of the normal payload packet multiplexing capability of the GTP protocol would not be available and only one payload packet could be carried at a time (using the length information gained from the lower layer). This means that especially with small packets, the relative total header octet overhead would be significantly bigger than with the standardized normal GTP frame.
- Additionally there would be the disadvantage of having to process a bigger amount of packets through the stack (up and down), so the Iu-PS user plane performance would decrease with the lightweight GTP scenario "A" also due to that drawback which would affect all the lower layers.

Considerations about the alternative scenario "B":

- The size advantage of the lightweight GTP-U alternative "B" is only 2 octets in comparison to the normal, standardized and very widely used GTP header. (If the Sequence Number length would be sacrificed to be only half of the normal size, then one additional octet would be saved.)
- The price to be paid for establishing the lightweight GTP-U header alternative "B" would anyway be very high: A new protocol side variant would need to be standardized and implemented for two node types, and maintained also in the future in the standards and the products. Also, additional product testing and documentation would be always required when new product releases are made. This would be against the general principle of keeping the interfaces as simple as possible and the protocol variants as few as possible.
- What comes to the performance, there is no difference in practice between the alternative "B" and the normal GTP header, since the hardware typically reads the data fastest when the number of octets is dividable by 4, so even here the gained advantage looks very questionable. As known, the bandwidth is typically limited much earlier by the data processing power than by the transmission path as such.

In conclusion to the detail considerations above, the normal, already standardized and implemented GTP protocol header seems the best alternative for the Iu-PS user plane (in addition to being in the control plane).

### 6.13.1.8 Motivation for GTP-U

For many applications, data must be delivered in the same order that it was sent. In IP networks it is possible that packets will be reordered or lost in the network. Therefore, sequencing information is required to allow data to be delivered to the application in the correct order and to detect lost data. The support mode of the Iu framing protocol (IuFP) could provide a frame number, which is used to detect lost frames. It is not used to reorder out of order frames, which may be required by some applications.

The transparent mode of the Iu framing protocol has no functionality so it does not provide sequence information. For applications that require in-sequence delivery but use the IuFP in transparent mode, the transport layer must provide it. One such application is transparent circuit switched data [48].

GTP-U should be used for the transport protocol over UDP for the following reasons:

- 1) GTP-U provides the required sequence information.
- 2) GTP-U is already used on the IuPS interface. Since it meets the requirements for the IuCS there is no reason to introduce a new protocol in the RNC for the IuCS.
- 3) GTP-U is a simple protocol.

## 6.13.2 RTP for Iu-CS interface

### 6.13.2.1 Reasons for selecting an RTP/UDP/IP based Iu-CS User Data Transport stack

Enabling voice quality monitoring by performing measurements and providing communication between sending and receiving side.

- Voice quality information is seen to be extremely important for network operators to meet typical requirements stemming from real-time traffic. Performing measurements requires sequence numbers and time stamp information to derive information about the quality of an IP trunk in terms of loss and delay (delay jitter). GTP-U does not have a time stamp.



- Quality reports from the receiving to the sending side of an IP trunk is a prerequisite for adaptive mechanisms (e.g adaptive connection admission control or routing mechanisms depending on the QoS of an IP trunk).

RTP provides the means to perform QoS monitoring.

- RTP and RTCP provide the means for in-sequence integrity/reordering and QoS monitoring of VoIP trunks.

RTP is a standard IETF solution.

- RTP/UDP/IP currently is the only IETF conform solution for real-time transport. Deciding upon this solution will follow a design principle, that has been established within RAN3, i.e. to follow a standard IETF solution.

RTP is already optimized to be combined with Udp/IP.

- For example, it authorizes a combined compression with existing mechanisms leading to a compressed length of 2 bytes whereas the GTP cannot share the compression context with UDP/IP and leads to 14 bytes overhead (12+2). This efficiency is very sensible (e.g. for voice flows)."

## 6.13.2.2 Motivation for not choosing the RTP alternative

### 6.13.2.2.1 General

There have been contributions to RAN3 that propose the use of RTP for the IuCS interface. The main motivations for using RTP provided in those contributions are:

- It is used in the 3GPP circuit-switched core network for the Nb interface.
- RTP has capability that is needed for real-time services over the IuCS interface.
- RTP is an IETF protocol.
- Bandwidth utilization.
- The following clauses address these points for RTP.

### 6.13.2.2.2 Commonality with Nb interface

The transport protocols are completely terminated in the media gateway on each interface. There are separate transport sessions established for the Iu interface and the Nb interface. Even if RTP were used on both the Iu and the Nb, the RTP sessions and stacks would be completely terminated on the Iu endpoint and the Nb endpoint in the MGW.

It is still to be investigated whether timing information from the transport layer needs to be transferred between the Iu and Nb interfaces even though relevant timing information for an application is contained in the Iu/Nb framing protocols. There is a "through connect" mode defined for the MGW but this is only at the framing protocol level, not at the transport layer level. RTP is terminated but the framing protocol is not.

### 6.13.2.2.3 Special RTP capability

The IP transport requirements for real-time traffic on the IuCS interface is the same as for the real-time traffic over the Iub and Iur interfaces. The Iub interface has the strictest quality of service requirements since it can be a low speed link. RTP has not been proposed for these interfaces and is not being considered.

According to RFC 1889, RTP is primarily designed to satisfy the needs of multi-participant multimedia conferences using IP multicasting but it is not limited to that particular application. The IuCS interface does not require multi-participant capability from the transport layer. Only unicast transport is required. Therefore, some of the capability defined around RTP is not required.

It has been proposed that the quality reporting functionality of RTP (using RTCP) is important for the IuCS. However, as discussed for the Iub and Iur interfaces during the IP UTRAN study, quality of service and resource management should be handled at the IP layer and below. The use of quality feedback at the application layer should not be required. Quality reporting is also not needed for rate control. This is handled by the Iu framing protocol.

In the RTP RFC, quality of service monitoring is mandatory for multicast applications and optional for unicast applications.

#### 6.13.2.2.4 Bandwidth utilization

The Iu interface is a high-speed interface so bandwidth utilization is not a high priority as it is for the Iub interface. RTP and GTP-U have the same header size (12 octets) when the sequence number is used with GTP-U. When the sequence number is not used with GTP-U, the header size is 8 octets. Without header compression, both the RTP and GTP-U header sizes are less significant in comparison with the IP/UDP headers.

Header compression can be used with both RTP and GTP-U packets. Since the Iu is a high-speed interface, it is not practical for each router to perform header compression on a link by link basis. Alternatively, header compressed packets can be tunneled in PPP frames in an L2TP tunnel. Since the compressed packets are tunneled, they are not decompressed/compressed at each hop.

If it is determined that bandwidth utilization is an important concern for the Iu interface, then RTP has some bandwidth utilization advantage when tunneling compressed packets in PPP frames. RTP compression is performed in conjunction with IP/UDP compression so the resulting header is small. With GTP-U, the IP/UDP headers can be compressed but not the GTP-U header. It should be decided if GTP-U with compressed IP/UDP headers is sufficiently efficient for the Iu interface.

It has been proposed to define a smaller GTP-U header that is optimized for real-time applications. Since this optimized GTP-U header has not been specified yet it is not known how large it would be. However, RTP will have some amount of bandwidth utilization advantage even with an optimized GTP-U header.

---

## 7 Agreements and associated agreed contributions

This clause documents agreements that have been reached and makes reference to contributions agreed in RAN-WG3 with respect to this study item. This clause is split according to the above mentioned Study Areas.

### 7.1 External standardization

### 7.2 QoS differentiation

The user plane protocol stack standardized for IP transport shall not preclude any of the following two network configurations:

- QoS differentiation provided by the IP network on a hop-by-hop basis, and
- QoS differentiation provided on an edge-to-edge basis.

The standard shall not preclude any of the following alternatives within the transport network:

- flow per flow or aggregate classification,
- classification based on packet per packet information or on flow addressing information,
- classification made on information provided by the transport bearer initiator.

The needed information for quality of service differentiation between several UTRAN flows shall be available at the IP layer used for RNL flow addressing. The UTRAN NEs shall provide this QoS information to this IP layer.

It is agreed that:

- 1) The IP hosts terminating the IP UTRAN transport interfaces (Iu, Iur, Iub) shall support Diffserv codepoint marking.
- 2) The Diffserv codepoint may be determined based on an operator configurable mapping from the application parameters.
- 3) This does not preclude the use of RSVP, configured UDP ports or over-provisioning, for example, if this is what an operator wants and its vendors support it.

## 7.3 Transport network bandwidth utilization

### 7.3.1 Multiplexing

No additional multiplexing layer/functionality shall be specified between UDP/IP and the UTRAN Frame Protocols since adequate solutions exist below IP achieving the UTRAN requirements.

PPPMux [10] provides efficient multiplexing capabilities for PPP.

It was agreed that it can bring bandwidth efficiency benefits in some cases (e.g. AAL5 framing) but it was also agreed that it will not be included in the final specifications.

All multiplexing scenarios, introduced in clause 6.4.1.1.1, figure 6-12, bring specific benefits and shall be supported for IP Transport in UTRAN.

## 7.4 User plane transport signalling

ALCAP is not required over the Iu (PS and CS), Iur and Iub interfaces between two IP UTRAN nodes or between IP UTRAN nodes and IP-CN.

## 7.5 Layer 1 and layer 2 independence

The use of one exclusive L2 protocol shall not be standardized for IP transport. One or a limited set of L2 protocols shall be specified and required. The use of any L2 protocol fulfilling the UTRAN requirement towards layer one and two, shall not be precluded by the standard. Every IP UTRAN Node shall be able to support the PPP protocol [11]

Because of concerns over interworking in the point-to-point case, all IP UTRAN Nodes shall be able to support HDLC framing [12]. This does not preclude the single implementation and use of any other L2/L1 protocols (e.g. PPPMux/AAL5/ATM [15], PPP/AAL2/ATM, Ethernet, MPLS/ATM, etc.).

NOTE: No L2 termination between the two peer UTRAN Nodes.

It should be clear from above that the decision is left to the operators for selecting the appropriate L2/L1 taken into account the potential issues of interworking and performance.

UTRAN NEs having interfaces connected via slow bandwidth PPP links like E1/T1/J1 shall also support IP Header Compression [51] and the PPP extensions ML/MC-PPP [20], [21]. Negotiation of header compression [51] over PPP shall be performed via [14].

## 7.6 Radio Network Signalling bearer

SCTP protocol shall be supported on Iub interface as signalling bearer for the NBAP application with the following stack when IP Transport option is selected.

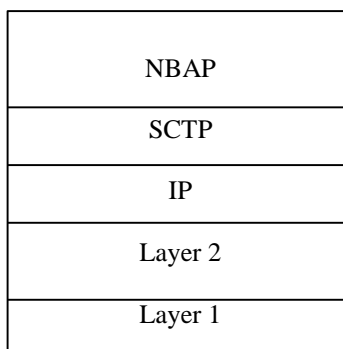

On Iub, each signalling bearer between the RNC and Node B shall correspond to one single SCTP stream in UL and one single SCTP stream in DL direction, both streams belonging to the same SCTP association.

The following Radio Network Signalling bearer protocol stack shall be supported on the Iu-cs, Iu-ps and Iur interfaces when IP Transport option is selected.

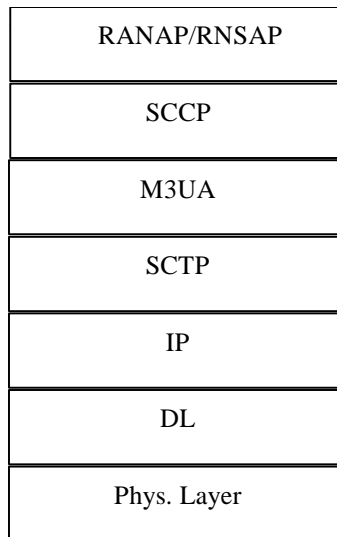

## 7.7 Addressing

The IP UTRAN nodes shall identify the user plane transport bearers in the Iub, Iur and IuCS interfaces by the UDP port number plus IP address (source UDP port number, destination UDP port number, source IP address, destination IP address).

IP addresses shall be communicated via the radio network layer protocols (RANAP, RNSAP, NBAP) using the NSAP structure [Annex A of 0], 0 for Iub, Iur and Iu-cs. The NSAP structure (encapsulation) is only used in the radio network layer, in order to provide explicit identification of the type of the TNL address that is being conveyed by the given RNL protocol.

NSAP structure is not used in RANAP in Iu-ps but Iu-ps shall retain the 'straight IP addressing' as is the case for Release 99 and Release 4."

The following figure depicts the encapsulation of a native IPv6 address in NSAP structure when conveyed in RANAP, RNSAP and NBAP.

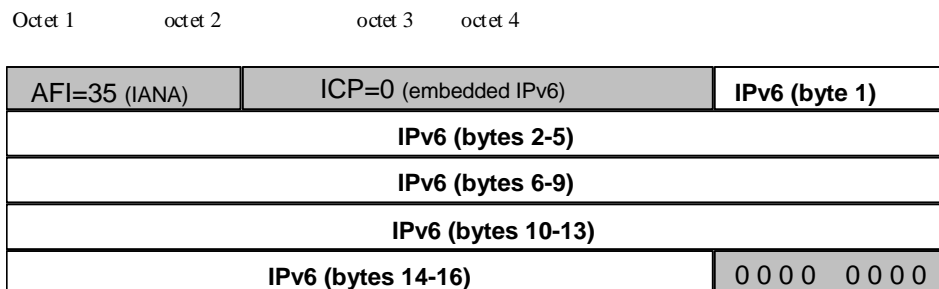

Figure 7-3: IPv6 address embedded in NSAP structure in RANAP/RNSAP/NBAP

## 7.8 Transport architecture and routing aspects

IP Hosting is a necessary function for a network element supporting of the UTRAN functions (Node B, RNC).

UTRAN NEs shall have at least one IP address, onto one or several IP subnets.

No restriction is imposed, regarding routing domains and autonomous systems.

## 7.9 Backward compatibility with R99-R4/Coexistence with ATM nodes

The IP transport option shall ensure the co-existence of an ATM only UTRAN Node, an IP only UTRAN Node, or an UTRAN Node with both ATM and IP transport options in the UTRAN. An IP UTRAN node shall provide coexistence with an ATM UTRAN Node via one of the followings:

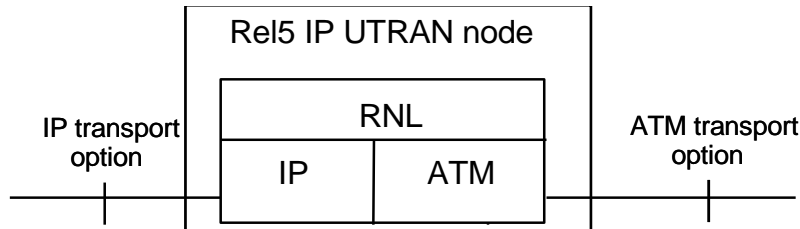

Figure 7-4: Dual-stack capability

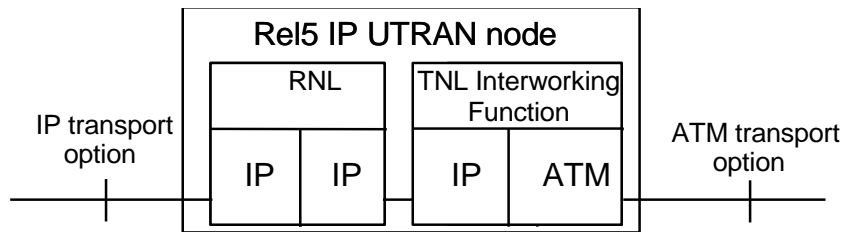

Figure 7-5: Interworking function, which is a logical part of the Rel5 IP UTRAN node, that enables each IP UTRAN node a 3GPP compliant Rel99/Rel4/Rel5 interface towards the UTRAN nodes having ATM transport option

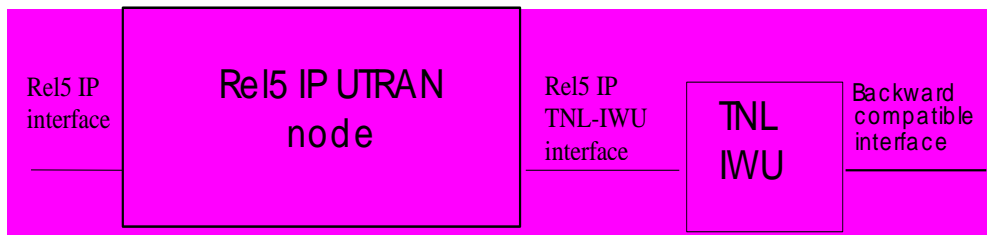

Figure 7-6: A TNL Interworking Unit present between the IP UTRAN Node and the ATM UTRAN Node

The traffic and QoS parameters signalled from the Rel5 IP node to its TNL-IWU in the Rel5 IP TNL-IWU interface are generic in nature (transport independent). These parameters are used for determining the needed transport resources in the TNL-IWU.

The following parameters are used:

- TNL QoS Class: represented by a 8 bit field (e.g. defines the delay, delay variation and loss priority). The meaning of the bits are operator defined.
- Bit rate (max & average).
- SDU size (max & average).

## 7.10 Synchronization

It is recommended that clause 4.2 of TS 25.411 [60] should be split into two subclauses. One for synchronized case (proposal 4.2.1) and one for unsynchronized case (proposal 4.2.2). The synchronized case would be the ATM case. The unsynchronized case needs different wording than the current proposal. It was suggested that Motorola modifies proposal 4.2.2 for clarification.

It shall be allowed to use Layer 1 interfaces that do not provide synchronization reference information in the IP UTRAN transport.

## 7.11 Security

It is agreed that the IP network used for Rel5 IP UTRAN is a closed network.

The definition of a closed network is as follows: there is no access from other networks or by other users to any of the physical interfaces and transmission links used for UTRAN transport (Iu, Iur, Iub).

It is also agreed that, within the closed network as above defined, the internal security threats can be considered negligible.

## 7.12 Iu-cs/Iu-ps harmonization

## 7.13 Iur/Iub User plane protocol stacks

On the Iub interface, the following user plane protocol stack shall be supported when IP Transport option is selected. Note that UDP/IP header compression usage is stated in clause 7.5:

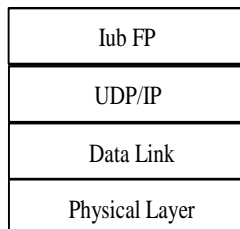

On the Iur interface, the following user plane protocol stack shall be supported when IP Transport option is selected. Note that UDP/IP header compression usage is stated in clause 7.5:

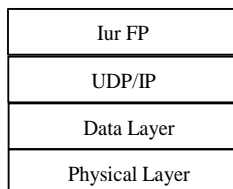

## 7.14 Iu-cs/Iu-ps user plane protocol stacks

### 7.14.1 Iu-cs

RTP protocol [59] shall be used on Iu-CS interface resulting in the following stack:

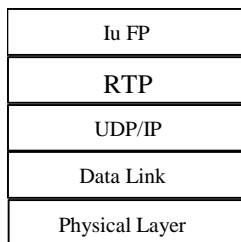

The support of RTCP [59] is optional (RNC and MGW may ignore RTCP packets).

## 7.14.2 Iu-ps

The protocol stack for the Rel5 Iu-PS User plane is GTP-U [46]/UDP/IP.

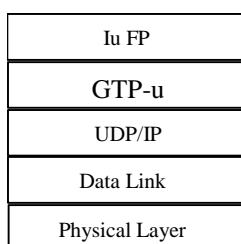

## 7.15 IP version issues

For Iu, Iur and Iub interfaces, it is agreed that, when IP Transport option is selected:

- UTRAN Nodes shall support IP version 6 [27],
- UTRAN Nodes may support IP version 4 [49] as an option.

"Because of transition period it is felt preferable that dual stack support is the best way to evolve. This does not prevent single stack support (IPv4 or IPv6). The decision is then left for operators taking into account the potential interworking or performance consequences."

# 8 Specification Impact and associated Change Requests

This clause is intended to list the affected specifications and the related Change Requests agreed. It also lists the possible new specifications that may be needed for the completion of the Work Task.

## 8.1 TS 25.401

### 8.1.1 Impacts

This clause is intended to make reference to contributions and agreements that affect the specification.

### 8.1.2 List of Change Requests

This clause lists the agreed Change Requests related to the specification.

CR 044, CR048, CR052, CR053

## 8.2 TS 25.410

### 8.2.1 Impacts

### 8.2.2 List of Change Requests

CR 032

## 8.3 TS 25.411

### 8.3.1 Impacts

### 8.3.2 List of Change Requests

CR009

## 8.4 TS 25.412

### 8.4.1 Impacts

### 8.4.2 List of Change Requests

CR 010

## 8.5 TS 25.413

### 8.5.1 Impacts

### 8.5.2 List of Change Requests

CR 419, CR466

## 8.6 TS 25.414

### 8.6.1 Impacts

### 8.6.2 List of Change Requests

CR 030



## 8.7 TS 25.415

### 8.7.1 Impacts

### 8.7.2 List of Change Requests

CR 095

## 8.8 TS 25.420

### 8.8.1 Impacts

### 8.8.2 List of Change Requests

CR 024

## 8.9 TS 25.422

### 8.9.1 Impacts

### 8.9.2 List of Change Requests

CR 011

## 8.10 TS 25.423

### 8.10.1 Impacts

### 8.10.2 List of Change Requests

CR 555

## 8.11 TS 25.424

### 8.11.1 Impacts

### 8.11.2 List of Change Requests

CR 020

## 8.12 TS 25.426

### 8.12.1 Impacts

### 8.12.2 List of Change Requests

CR 022

## 8.13 TS 25.430

### 8.13.1 Impacts

### 8.13.2 List of Change Requests

CR 030

## 8.14 TS 25.432

### 8.14.1 Impacts

### 8.14.2 List of Change Requests

CR 001

## 8.15 TS 25.433

### 8.15.1 Impacts

### 8.15.2 List of Change Requests

CR 597

## 8.16 TS 25.434

### 8.16.1 Impacts

### 8.16.2 List of Change Requests

CR 021

## 8.17 TS 25.442

### 8.17.1 Impacts

### 8.17.2 List of Change Requests

CR 002

---

## 9 Project Plan

### 9.1 Schedule

void

	Meeting	[expected] Input	[expected]Output
August, 2002	RAN3#31	CRs to TNL-IWU protocol	CRs to be submitted to TSG-RAN#17

### 9.2 Work Task Status

	Milestone	Status
1.	Requirements definition ( 5 )	Completed
2.	User Plane (6.2)	Completed
3.	Transport Architecture and routing aspects ( 6.9)	Completed
4.	Radio Network Signalling Bearer ( 6.7 )	Completed
5.	Transport network bandwidth utilisation ( 6.4)	Completed
6.	User plane transport signalling ( 6.5)	Completed
7.	QoS ( 6.3)	Completed
8.	Addressing (6.8 )	Completed
9.	Backward compatibility with R99-R4/ Coexistence with ATM nodes ( 6.10)	Study area completed. Agreements on scenarios completed. No agreement yet on the protocol for external TNL- IWU scenario.
10.	Layer 1 and Layer 2 independence (6.6)	Completed
11.	Synchronisation (6.11)	Completed
12.	Iu-cs/Iu-ps harmonisation ( 6.13)	Completed

13.	Security ( 6.12)	Agreements only in the case of closed network. SA3 has taken the responsibility for further work.
14.	External Standardisation (6.1)	Work in progress related to Coexistence with ATM nodes (external TNL-IWU scenario).

---

## 10 Open Issues

Backward compatibility with R99-R4/Coexistence with ATM nodes: In the case of TNL Interworking Unit between the IP UTRAN Node and the ATM UTRAN Node, three proposals are still under discussion:

1. Bearer control proposal using IETF SIP/SDP
2. Bearer Control proposal using a new protocol ("Q.IP-ALCAP"),  
optimised for concatenation with AAL Type 2 links
3. IP-ALCAP based on Q.2630



---

## Annex A: Simulation Model

### A.1 Introduction

The simulation model is intended to give criteria to compare different IP based Iub User Plane protocol stacks. ATM/AAL2 will be used as a baseline case for comparison.

---

### A.2 Simulation scenarios

Four different traffic mixes are defined for the simulation runs:

- 100 % voice,
- 100 % data,
- 80 % voice & 20 % data, with 5 voice users per data user
- 20 % voice & 80 % data, with 3 data users per voice user.

Data rates are 64, 144 and 384 Kbps.

Throughput will be specified as a percentage of used bandwidth at source level, not including TNL protocol overheads (but TNL protocol overhead is included in simulation).

NBAP and O&M traffic will not be included in simulations.

---

### A.3 Simulation model framework

The general simulator model can be split in four parts which are nearly independent from each other.

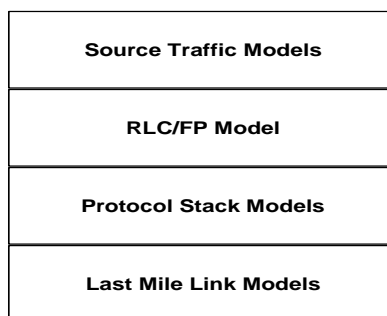

**Figure A-1: General Simulator Model**

This modular concept allows an efficient reuse of simulator modules for the investigation of different proposed protocol stacks and provides transparency for comparison.

---

### A.4 Source Traffic Models

#### A.4.1 Speech source model

For simulation, speech sources are based on AMR codecs with only the 12,2 kbps mode. Each AMR 12,2 kbps source is modelled with an ON/OFF model for DTX, having the following statistics:

- Voice Call Duration Distribution: Exponential, mean: 120 s.
- Duration of On-state Distribution: Exponential, mean: 3 s.
- Duration of Off-state Distribution: Exponential, mean: 3 s.

## A.4.2 Data source model

Two equivalent data source models can be used:

### A.4.2.1 Data Source Model 1

Each data user is modelled as a WWW application, consisting of a sequence of file downloads. Each file download is modelled as a sequence of packet arrivals, having the following statistics.

**Data model:** Each web browsing download has Pareto distributed file size with a parameter  $\alpha = 1,1$ , mean 12,000 bytes, minimal file size 1 858 bytes, maximal file size 5 000 000 bytes. The p. d. f. (probability density function) is

$$f(x) = \begin{cases} \frac{\alpha \cdot k^\alpha}{x^{\alpha+1}}, & k \leq x \leq m \\ \frac{k^\alpha}{m^\alpha}, & x > m \end{cases}, \text{ where } \alpha=1.1, k=1858, \text{ and } m=5,000,000$$

Chop the file into IP packets with size of 1 500 bytes (and one less than 1 500 bytes if size is not a multiple of 1 500).

Inter-arrival time of IP packets is exponentially distributed with mean of 8,3 ms. This yields about 1445,78 Kbps IP packet arrival rate (larger than 64, 144, 384 Kbps data transmission rates). Therefore, the inter-arrival time has no significant impact on simulation results.

Reading time is defined by the time that the last bit of a file leaves from the RNC (G. data queue on the Figure 1) to the time that the first bit of the next file arrives to the "C. RLC data buffer". The distribution of reading time is exponential with mean 12 sec.

### A.4.2.2 Data source model 2

Interactive data traffic is mainly generated by WWW serving. As for the background traffic, the number of active users will be assumed to be constant. The parameters are listed in table A-1.

**Table A-1: Interactive data traffic**

Class	Parameter	Values	Remark
Transmission	bit rate [kbit/sec]	64, 144, 384	
Packet Call	# of packets per call distribution	Geometric	
	# of packets per call mean	25	
	packet inter arrival time distribution	Exponential	Packet inter arrival time within a packet call
	packet inter arrival time mean	0.0083 sec	
	inter packet call time distribution	Exponential	Reading time between to consecutive packet calls
reading time mean	12 sec		
Packet	packet size mean	480 bytes	Pareto PDF: $\frac{\alpha k^\alpha}{x^{\alpha+1}}$ If X is a Pareto distributed random variable then packet sizes are computed as $P=\min(X,m)$ . Parameters are not independent.
	packet size distribution	limited Pareto with $\alpha=1.1$ , $k=81.5$ , $m=66666$	

## A.5 RLC/FP model

### A.5.1 Voice Traffic

The RLC layer is transparent for voice traffic. Therefore, no overhead and no functionality is required in the simulation model for voice traffic in the RLC layer.

In the frame protocol, flows are composed to streams, which results in additional overhead as summarized in table A-2. The frame protocol PDU has a header of 2 Bytes and a trailer of 2 Bytes which results in a general 32 bit overhead per PDU. Each flow in the PDU has an overhead of 8 bits for the TFI, according to [8]. In the frame protocol, each flow will be padded to 8 bit boundaries which results in additional overhead.

**Table A-2: Parameters for Stream Overhead**

Class	Parameter	Value/Size	remark
Stream	overhead per stream packet (CRC + CFN)	32 bit	Overhead added per stream packet, regardless of its contents
Flow	overhead per flow (TFI)	8 bit	Overhead added once per flow in each stream packet

The following example explains the FP PDU generated for the 12,2 kbit/s AMR mode in ON state.

- 1) Header CRC, CFN 2 bytes;
- 2) 4 flows (DCH0-3) for class A, class B, class C and signalling;
  - a) 4 x 8 bit TFI 4 bytes;
  - b) 81 bit class A + padding 11 bytes;
  - c) 103 bit class B + padding 13 bytes;
  - d) 60 bit class C + padding 8 bytes;
  - e) signalling 0 or 10 bytes;
- 3) Payload CRC 2 bytes.

Signalling is assumed every 300 ms.

### A.5.2 Packet data Traffic

The RLC/FP splits the input packets into segments and also aggregates segments to new packets. While the input queue is not empty one or more new packets are created per TTI. Their size is chosen from a connection specific set of possible packet sizes. Depending on the signalled TFS, multiple small packets or one large packet are used to satisfy the transmission demand. If required, padding packets are used as input to extend the new packets to the smallest possible allowed size.



**Table A-3: Packet data traffic RLC/FP model parameters**

Class	Parameter	Value/Size	remark
Scheduler	inter packet time	TTI of the connection	
Packet Control	packet overhead	16 bit	Length Indicator
Segment Control	segment size set	{0, 320} bits	
	segment overhead	16 bit	
Transport Format	Peak data rate	64 kbps	
		144 kbps	
		384 kbps	
	RLC Buffer size	256 kByte	
	TTI	40 ms	20 ms optional
	TF set size	64 kbps	{0,1,2,3,4,6,8} x 336 bits
144 kbps		{0,1,2,4,8,16,18} x 336 bits	
384 kbps		{0,1,2,4,8,12,16,20,24,32,40,48} x 336 bits	

## A.6 Protocol Stack Models

### A.6.1 Overview

By investigating the protocol stacks for IP transport e.g. PPPmux or CIP one can find that the modules needed for implementation are:

- header compression (FFS);
- packetizer;
- queues;
- and the scheduler providing the prioritization for the voice traffic.

In the different protocol stacks these functions are provided by different layers. For the performance study these functionality can be modelled equally for all protocol stacks. The performance depends only on:

- header overhead per stream which can not be shared;
- header overhead per container to be sent over the link;
- the position of the packetizer;
- the position of the queues and scheduler.

The overhead can be introduced by parameters. The positions for the packetizer and the queues with the scheduler depend on the chosen implementation of the protocol stack. The implementations can be optimized per protocol stack depending on the QoS strategy. Two possible structures are shown in figures A-2 and A-3. The structure implemented in the simulator model shall be given together with the simulation results.

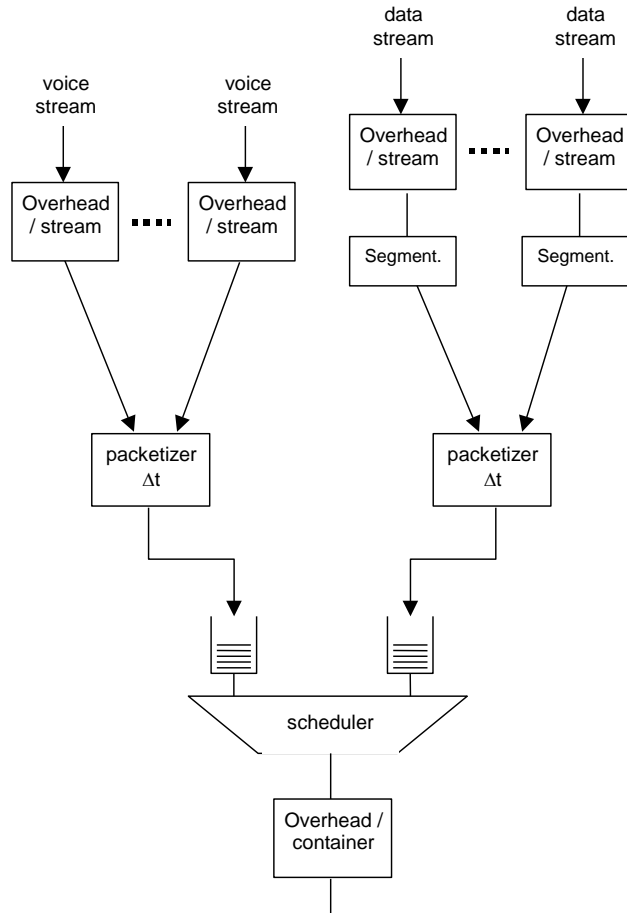

Figure A-2: Implementation Structure, Variant 1

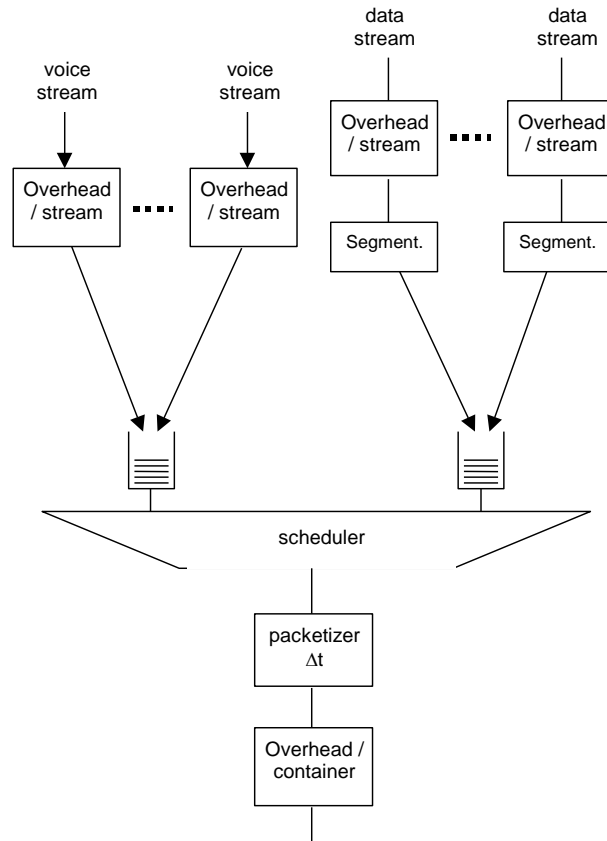

Figure A-3: Implementation Structure, Variant 2

## A.6.2 Module Functions

### A.6.2.1 Header Compression (FFS)

[Editor's note: contributions are invited]

### A.6.2.2 Packetizer

The packetizer composes the input packets to containers up to a maximum size or up to a maximum time. This process introduces additional delay to the streams.

Table A-4: Packetizer Parameters

Class	Parameter	Example Value	remark
Container	time out	0,003 sec	Maximum delay time
Control	max container size	2400 bit	Maximum container size

### A.6.2.3 Queues

Due to the limited bandwidth of the Last Mile Link Model queues must be provided. This process introduces additional delay to the streams.

Table A-5: Queue Parameters

Class	Parameter	Example Value	remark
Queue Control	Strategy	FIFO	
	max. size	infinite	No packet loss

### A.6.2.4 Segment Function

The segment function splits the input packets to segments down to a fixed size. The related overhead shall be introduced on a per stream or per container basis depending on the implementation. This process introduces no delay to the streams.

**Table A-6: Segment function Parameters**

Class	Parameter	Value	remark
Segment Control	Segment size	tbd	

### A.6.2.5 Scheduler

The scheduler is a functional entity, which provides prioritized service for two input queues. In our model one voice queue and one data queue are assumed. The voice queue shall be serviced until empty, at which time the data queue shall be serviced until the voice queue has become non-empty or the data queue is also empty. Voice packets cannot preempt data packets.

### A.6.3 Examples

In the following table examples are given how the Protocol Stack Model could be used for protocols already introduced in above clauses.

**Table A-7: Examples**

Protocol	Structure	Overhead/stream	Overhead/container
Protocol 2	Variant 2	CUDP 3 byte PPPIen 1 byte	PPPID 1 byte PPPMux 1 byte HDLC 3 byte
Protocol 1	Variant 1	CIP 3 byte	CUDP 4 byte PPP 1 byte HDLC 3 byte

---

## A.7 Last Mile Link Models

A point-to-point connection between the Edge-Router and the Node B is considered as Last Mile Link. It shall be modelled as infinite server providing a fixed service rate.

**Table A-8: Link Parameters**

Class	Parameter	Value	remark
Link Model	n*E1	n=1	1,92 Mbps
		n=2	
		n=3	

A single E1 link is assumed.

---

## A.8 Performance criteria

The most important performance criteria are delay and link utilization. The delay figures contain the packetization delay, the queuing delay and the transmission delay per individual stream. Confidence intervals shall be calculated based on the results of several independent simulation runs. Empirical studies have shown that about 10 simulation runs are the optimum to minimize computation time by still giving good statistical confidence. The duration of one simulation run depends on the required confidence interval size. It is not possible to make an accurate forecast about the

required simulation time to achieve good statistical confidence. Therefore, the simulation time must be increased if the results are not meaningful. It is important for the reporting of simulation results that confidence intervals are included.

**Table A-9: Performance criteria**

<b>Statistic</b>	<b>Confidence Level</b>	<b>Remarks</b>
99.9-percentile voice delay	0.95	
link utilization		Confidence level not important, can be calculated analytically
99.9-percentile transmission delay	0.95	
99.9-percentile packetization delay	0.95	

## Annex B: Appendix

This appendix refers to "Bearer Control proposal using modified Q.AAL2" solution for ATM/IP interworking described in clause 6.10.5.2.

For the Delta-Specification [IPALCAP], it is supposed to include in [52] the changes as highlighted in subclauses below:

### B.1 Additions table 7-6, clause 7.2.2 of [2]: Parameters of the AAL type 2 signalling protocol messages

**Table 7-6/IP-ALCAP: Parameters of the AAL type 2 signalling protocol messages (part 1 of 2)**

Parameter	Message						
	ERQ	ECF	REL	RLC			
Cause	–	–	M	(Note 5)			
Connection element identifier (Note 6)	M	–	–	–			
Destination E.164 service endpoint address	(Note 3)	–	–	–			
Destination NSAP service endpoint address	(Note 3)	–	–	–			
Destination signalling association identifier (Note 1)	(Note 2)	M	M	M			
Link characteristics	O	–	–	–			
Originating signalling association identifier	M	M	–	–			
Served user generated reference	O	–	–	–			
Served user transport	O	–	–	–			
Service specific information (audio)	(Note 4)	–	–	–			
Service specific information (multirate)	(Note 4)	–	–	–			
Service specific information (SAR-assured)	(Note 4)	–	–	–			
Service specific information (SAR-unassured)	(Note 4)	–	–	–			
Test connection indicator	O	–	–	–			
IP endpoint identifier	O	O	–	–			
M Mandatory parameter O Optional parameter – Parameter not present NOTE 1: This row designates the destination signalling association identifier field in the message header. NOTE 2: The destination signalling association identifier field contains the value "unknown". NOTE 3: Exactly one of these parameters must be present in an instance of the message. NOTE 4: At most one of these parameters is present in an instance of the message. NOTE 5: The "Cause" parameter is present in the release confirm message if: NOTE 6: The Connection element identifier contains the value "0" if the IP endpoint identifier exists. a) the RLC is used to reject a connection establishment; or b) the cause reports unrecognized information received in the REL message.							

## B.2 Additions to table 7-7, clause 7.2.2 of [2]: Parameters of the AAL type 2 signalling protocol messages

**Table 7-7/Q.2630.1: Identifiers of the AAL type 2 message parameters (concluded)**

AAL type 2 parameter	Ref.	Acronym	Identifier
Cause	7.3.1	CAU	00000001
Connection element identifier	7.3.2	CEID	00000010
Destination E.164 service endpoint address	7.3.3	ESEA	00000011
Destination NSAP service endpoint address	7.3.4	NSEA	00000100
Link characteristics	7.3.5	ALC	00000101
Originating signalling association identifier	7.3.6	OSAID	00000110
Served user generated reference	7.3.7	SUGR	00000111
Served user transport	7.3.8	SUT	00001000
Service specific information (audio)	7.3.9	SSIA	00001001
Service specific information (multirate)	7.3.10	SSIM	00001010
Service specific information (SAR-assured)	7.3.11	SSISA	00001011
Service specific information (SAR-unassured)	7.3.12	SSISU	00001100
Test connection indicator	7.3.13	TCI	00001101
IP endpoint identifier	7.3.14	IPEID	xxxxxxxx

## B.3 Additions to clause 7.3 of [2]: Parameter specification of the AAL type 2 signalling protocol messages

### 7.3.14 IP Endpoint Identifier

The sequence of fields in the IP endpoint identifier parameter is shown in table 7-xx.

**Table 7-xx/IP-ALCAP – Sequence of fields in the IP endpoint identifier parameter**

Field No.	Field	Ref.
1	UDP port number	7.4.19
2	IP address	7.4.20

## B.4 Additions to clause 7.4 of [2]: Field specification of the AAL type 2 signalling protocol parameters

### 7.4.19 UDP port number

The structure of the UDP port number field is shown in Table 7-yy; the field is a fixed size field of 2 octets.

**Table 7-29/IP-ALCAP – Structure of the UDP port number field**

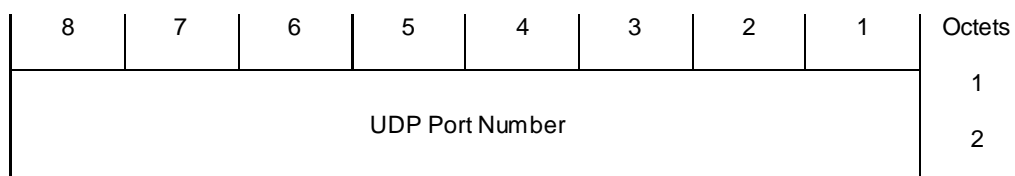

### 7.4.20 Served user transport

The structure of the IP address field is shown in Table 7-zz; the field is a variable size field.

**Table 7-zz/IP-ALCAP – Structure of the IP address field**

8	7	6	5	4	3	2	1	Octets
Field length								1
IP address								2
								n

The IP address field length can be either 4 (IPv4) or 16 (IPv6) octets.

## B.5 Additions to clause 8.2.2 of [2]: Nodal functions for AAL type 2 nodes without served user interaction

### 8.2.2.4 Interworking with AAL type 2 nodes conforming only to ITU-T Recommendation Q.2630.1

Interworking with AAL type 2 nodes conforming only to ITU-T Recommendation Q.2630.1 is guaranteed by setting the compatibility information on new messages and parameters as specified in annex C.

## B.6 Additions to the annex of [2]: Nodal functions for AAL type 2 nodes without served user interaction



## Annex C: Coding of the compatibility information

### C.1 Coding of the compatibility information

#### C1.1 Parameter compatibility

To ensure backward compatibility with AAL type 2 nodes conforming only to ITU-T Recommendation Q.2630.1, the parameter compatibility field of the new or differently used parameters shall be set as indicated in table C-1.

**Table C-1: Coding of the parameter compatibility information**

Parameter	8	7	6	5	4	3	2	1
	pass-on not possible				General action			
	Res.	send notification indicator	instruction indicator		Res.	send notification indicator	instruction indicator	
IP Endpoint Identifier (IPEID) in RLC message	0	0 do not send notification	0 1 discard parameter		0	0 do not send notification	0 1 discard parameter	

---

## Annex D: Change History

Change history							
Date	TSG #	TSG Doc.	CR	Rev	Subject/Comment	Old	New
03/2002	15	-	-		Approved at TSG RAN #15 and placed under Change Control	-	5.0.0
06/2002	16	RP-020421	001	2	IP-ALCAP: The ITU-T Solution	5.0.0	5.1.0
09/2002	17	RP-020628	003	1	Rapporteur's Corrections to TR25.933 IP Transport in UTRAN	5.1.0	5.2.0
06/2003	20	RP-030323	004*	2	Corrections to ATM-IP interworking	5.2.0	5.3.0
12/2003	22	RP-030681	005		Correction of PE-node as an ATM switch Solution	5.3.0	5.4.0

Note: \*: corrected from CR003 to CR004 after RAN #20