

TR 25.932 V2.0.0 (2000-10)

Technical Specification

**3rd Generation Partnership Project (3GPP);
Technical Specification Group (TSG) RAN;**

Delay Budget within the Access Stratum

UMTS <spec>



Reference

<Workitem> (<Shortfilename>.PDF)

Keywords

<keyword[, keyword]>

3GPP

Postal address

Office address

Internet

secretariat@3gpp.org
Individual copies of this deliverable
can be downloaded from
<http://www.3gpp.org>

Copyright Notification

No part may be reproduced except as authorized by written permission.
The copyright and the foregoing restriction extend to reproduction in all media.

©
All rights reserved.

Contents

1	SCOPE	6
2	REFERENCES	6
3	DEFINITIONS, SYMBOLS AND ABBREVIATIONS	7
3.1	DEFINITIONS	7
3.2	SYMBOLS	7
3.3	ABBREVIATIONS.....	7
4	EXTERNAL REQUIREMENTS ON UTRAN	9
4.1	GENERAL	9
4.2	PERFORMANCE EXPECTATIONS.....	12
4.2.1	<i>Real Time Services</i>	12
5	UTRAN DELAY COMPONENTS	13
5.1	GENERAL	13
5.2	UTRAN NETWORK COMPONENTS.....	13
5.2.1	<i>Macro-diversity Combining Delay</i>	13
5.2.2	<i>Interleaving for Convolutional and Turbo Coding</i>	13
5.2.3	<i>MAC Scheduling Delay</i>	14
5.2.4	<i>Re-transmission Delay</i>	14
5.2.5	<i>Radio Interface Propagation Delay</i>	15
5.2.6	<i>Processing Delays</i>	15
5.3	TRANSPORT NETWORK	16
5.3.1	<i>General</i> 16	
	<i>Multiplexing and De-multiplexing Delay</i>	19
5.3.3	<i>Play-out Buffer Delay</i>	20
5.3.4	<i>Transmission Delay</i>	20
5.3.5	<i>Media Delay</i>	21
5.3.6	<i>Switching/and Cross-Connecting Delay</i>	21
6	UTRAN DELAY ESTIMATION	22
6.1	UTRAN REFERENCE CONFIGURATION.....	22
6.2	NETWORK ASSUMPTIONS.....	22
6.3	TRAFFIC ASSUMPTIONS	23
6.4	DELAY BUDGET EVALUATION.....	23
7	BIBLIOGRAPHY	27
8	APPENDIX A	28
8.1	NON ACCESS STRATUM DELAY COMPONENTS	28
8.1.1	<i>Transcoding for Speech Services</i>	28
8.1.2	<i>Core Network</i>	28
8.1.3	<i>User Equipment</i>	29

9 APPENDIX B.....ERROR! BOOKMARK NOT DEFINED.

9.1 ROUND TRIP DELAY EVALUATION **ERROR! BOOKMARK NOT DEFINED.**

10 HISTORY..... 29

ANNEX A DOCUMENT STABILITY ASSESSMENT TABLE..... 31

ANNEX B OPEN ISSUES RELATING TO THIS SPECIFICATION..... 33

Disclaimer

Since the present Technical Report reports evaluations based on simulations, traffic and network assumptions, technological considerations related to processing operations, a certain degree of uncertainty must be considered when estimating the results provided by the document.

Intellectual Property Rights

Foreword

This Technical Report (TR) has been produced by the 3rd Generation Partnership Project (3GPP), Technical Specification Group RAN.

The contents of this TR are subject to continuing work within 3GPP and may change following formal TSG approval. Should the TSG modify the contents of this TR, it will be re-released with an identifying change of release date and an increase in version number as follows:

Version m.t.e

where:

m indicates [major version number]

x the second digit is incremented for all changes of substance, i.e. technical enhancements, corrections, updates, etc.

y the third digit is incremented when editorial only changes have been incorporated into the specification.

1 Scope

The present document evaluates the delay components introduced within the Access Stratum to provide guidelines useful both to provider for the dimensioning of a network and to manufacturers for the design of node elements. While the analysis of the possible delay sources is performed in an exhaustive way, the evaluation of single and global delay figures is limited to the case of Real Time services.

The estimation of Non Real Time service delays is not in scope of Release 99 and, therefore, it will not be considered in the present version of the Technical Report.

2 References

The following documents contain provisions which, through reference in this text, constitute provisions of the present document.

- References are either specific (identified by date of publication, edition number, version number, etc.) or non-specific.
- For a specific reference, subsequent revisions do not apply.
- For a non-specific reference, the latest version applies.
- A non-specific reference to an ETS shall also be taken to refer to later versions published as an EN with the same number.

- [1]: Technical Specification Group Services and System Aspects Service Aspects; Service and Service Capabilities - 3G TS 22.105 version 3.6.0 – (1999-10)
- [2]: Requirements for the UMTS Terrestrial Radio Access system (UTRA) (UMTS 21.01 version 3.0.1)- TR 101 111 V3.0.1 (1997-10)
- [3]: Quality of Service and Network Performance (UMTS 22.25 version 3.1.0) - TR 22.25 V3.1.0 (1998-03)
- [4]: ITU-T Recommendation G.174: Transmission Performance Objectives for Terrestrial Digital Wireless Systems using Portable Terminals to access the PSTN (6/94)
- [5] ITU-T Recommendation G.114: Transmission Systems and Media General Characteristics of International Telephone Connections and International Telephone Circuits - One-Way Transmission Time (02/96)
- [6]: Technical characteristics, capabilities and limitations of mobile satellite systems applicable to the UMTS (UMTS 30.20 version 3.1.0) - TR 30.20 V3.1.0 (1998-01)
- [7]: ITU-T Recommendation I.356: Overall network aspects and functions – Performance objectives (10/96)
- [8]: ATM Forum af-vtoa-0113.000, *ATM Trunking using AAL2 for Narrowband Services*, (2/99)

- [9]: ITU-T Recommendation I.363.2, *B-ISDN ATM Adaptation Layer Specification Type 2 AAL*, (10/97)
- [10] Liu Chunlei, Munir Sohail and Jain Raj, *Packing density of Voice Trunking using AAL2*, paper submitted to Globelcom'99
- [11] ATM Forum 98-0630 - Packet Delay Variation in Voice Trunking using AAL2, COMSAT Laboratories, (10/1998)
- [12] ATM Forum 98-0830 - Packing Density of Voice Trunking using AAL2, The Ohio State University & NOKIA Research Center (Burlington), (12/1998)
- [13]: Technical performance objectives (GSM 03.05 version 6.0.0 Release 1997) - TR 101 631 V6.0.0 (1999-04)
- [14]: ITU-T Recommendation G.168, *Digital network echo cancellers*, (04/97)
- [15] Channel coding and multiplexing examples - TR 25.944 v.1.0.1; 3GPP TSG RAN WG1

3 Definitions, symbols and abbreviations

3.1 Definitions

For the purposes of the present document, the following terms and definitions apply.

3.2 Symbols

For the purposes of the present document, the following symbols apply:

RT = Real Time

NRT = Non Real Time

3.3 Abbreviations

For the purposes of the present document, the following abbreviations apply:

AAL	ATM Adaptation Layer
AMR	Adaptive Multi Rate
ATM	Asynchronous Transfer Mode
BER	Bit Error Ratio
CBR	Constant Bit Rate
CDV	Cell Delay Variation

CN	Core Network
CPS	Common Part Sublayer
CRC	Cyclic Redundancy Check
CTD	Cell Transfer Delay
DL	Downlink
DRNC	Drift RNS
FDD	Frequency Division Duplexing
FEC	Forward error Coding
FER	Frame Error Ratio
GGSN	Gateway GPRS Support Node
GTP	GPRS Tunnelling Protocol
IMA	Inverse Multiplexing on ATM
ISDN	Integrated Services Digital Network
ITU	International Telecommunication Union
MAC	Medium Access Control
MDC	Macro-Diversity Combining
MP	Measurement Point
MSC	Mobile Services Switching Centre
NAK	Not Acknowledged
NRT	Non Real Time
PCM	Pulse Code Modulation
PCR	Peak Cell Rate
PDF	Probability Distribution Function
PDH	Plesiochronous Digital Hierarchy
PDV	Packet Delay Variation
PS	Packet Switched
PSTN	Public Switched Telephone Network
PTD	Packet Transfer Delay

RAN	Radio Access Network
RLC	Radio Link Control
RNC	Radio Network Controller
RT	Real Time
SAP	Service Access Point
SAR	Segmentation And Re-assembly
SCR	Sustainable Cell Rate
SDH	Synchronous Digital Hierarchy
SDU	Service Data Unit
SRNC	Serving RNC
STM	Synchronous Transfer Mode
TDD	Time Division Duplexing
TFO	Tandem Free Operation
TR	Technical Report
TRAU	Transcoder Rate Adaption Unit
TTI	Transmission Time Interval
UE	User Equipment
UL	Uplink
UMTS	Universal Mobile Telecommunication System
UTRAN	UMTS Terrestrial Radio Access Network
VCC	Virtual Channel Connection

4 External requirements on UTRAN

4.1 General

Reference [1] describes a range of Quality of Service (QoS) requirements to be supported by bearer services in UMTS.

The elements considered to characterise a bearer service are:

- Data rate;
- Maximum transfer delay defined as the time between the request to transfer the information at the originating access point to its delivery at the terminating access point;
- Maximum delay variation;
- BER/FER requirements;
- Information loss.

UMTS is going to provide services with the performance objectives specified in the following table:

Table 1: UMTS Performance Objectives (BER and Maximum Transfer Delay) [1]

Operating Environment	RT Services	NRT Services
Other than satellite (Indoor, Rural/Urban/Suburban/Low Range Outdoor)	Max transfer Delay 20-300 ms ^{*)} BER 10^{-3} to 10^{-7}	Max transfer Delay >150 ms ^{*)} BER 10^{-5} to 10^{-8}

^{*)} 95% quantile

The figures given shall be valid for both connection oriented and connectionless services. A compromise is likely to occur between BER and delay performances.

In the following figure it is reported from [2] the reference model for the computation of the transmission delay.

It should be considered that:

- The error protection contains any FEC, CRC, interleaving coding and macro-diversity processing.
- Speech encoding is not included in the radio transmission chain since it is assumed there will be bearer definitions applicable for speech transmission, as well as for video compression etc.

The one-way delay figures are only applicable for defining the radio technology bearers and not for defining the complete access delay for the radio access network. This means that the total delay will be larger. Thus the figures T_t and T_i must be lower than the requirement for total delay in the access network.

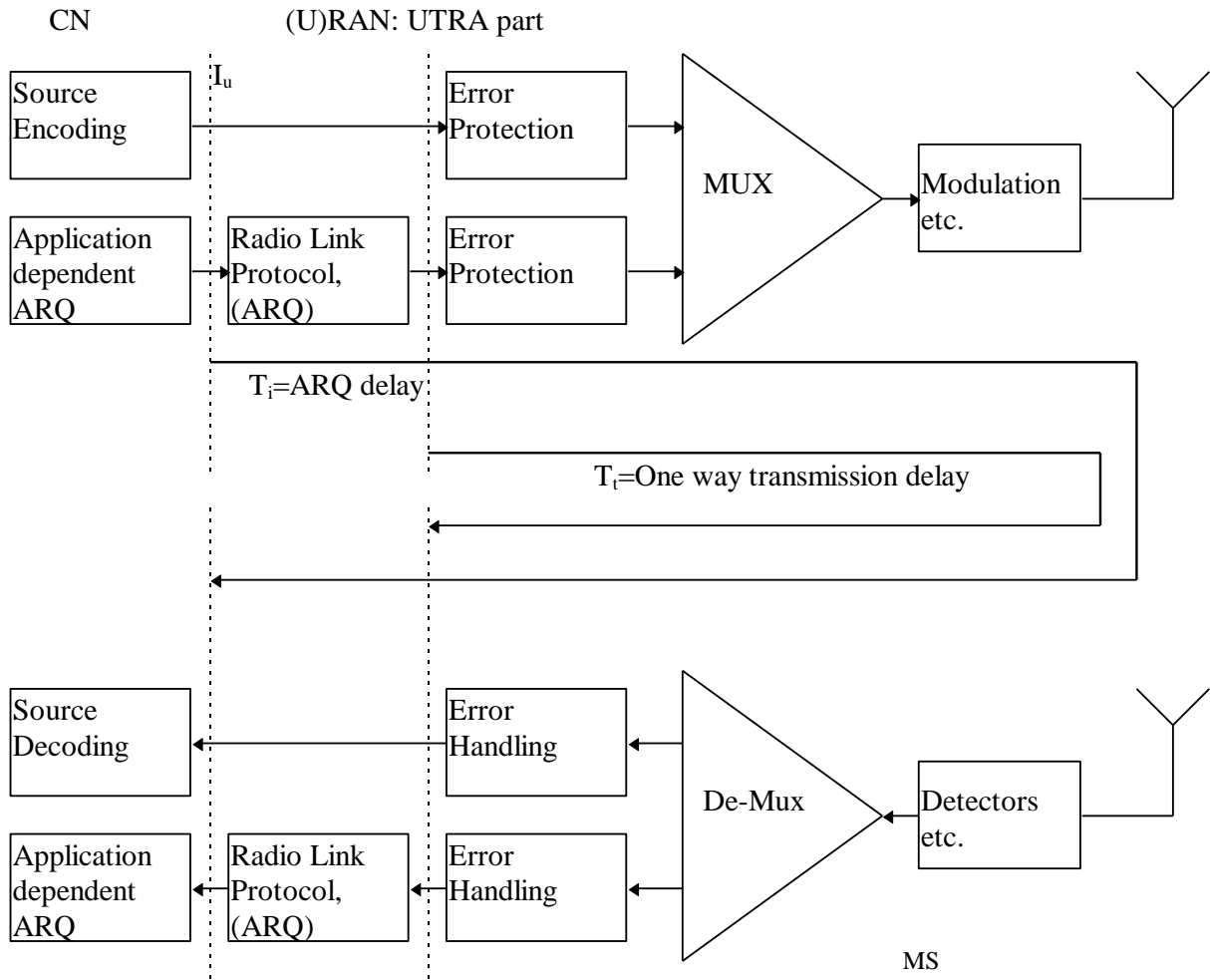

Figure 1: Reference Model for Transmission Delay [2]

The reference points of measurement positioned on the Access Stratum boundary are highlighted in the following figure with regard to the architectural structure of UTRAN

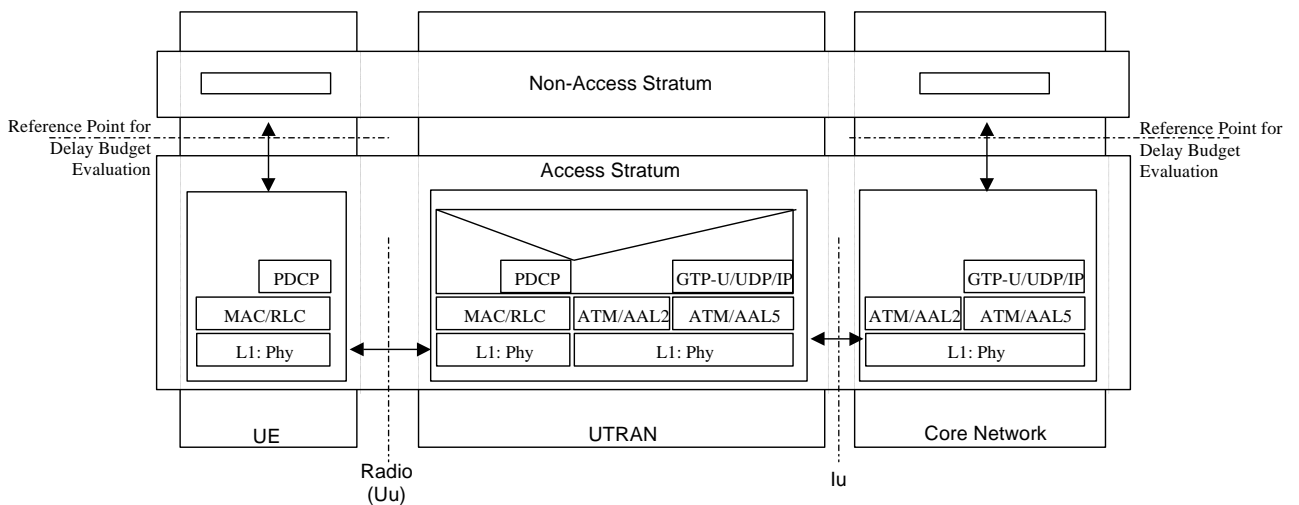

Figure 2: Reference Points of Measurement of the Delay Budget within the Access Stratum

4.2 Performance Expectations

4.2.1 Real Time Services

In the following table end-to-end performance expectations for real time services identified in [1] are given:

Table 2: Performance Expectations for RT Services [1]

Application	Data rate range	Key Performance Parameters and Target Values		
		One-way Delay	Delay Variation	Information Loss
Conversational voice (Audio)	4-25 kbit/s (Two-way, Symmetric)	Preferred <150 ms Limit <400 ms	< 1 ms	< 3% FER
Videophone (Video)	32-384 kbit/s (Two-way, Symmetric)	Preferred <150 ms Limit <400 ms Lip sync: <100 ms		< 1% FER
Telemetry, Interactive games, Telnet (Data)	<28.8 kbit/s (Two-way, Symmetric or Asymmetric)	< 250 ms	N.A	Error intolerant service

For the evaluation of the Delay Budget within the Access Stratum, the following representative real time applications have been identified:

Table 3: Real Time representative Applications for Evaluation Purposes

Application	Data Rate (kbit/s)
AMR Codec (Audio)	12.2
ITU-T H.324 (Video)	32
ITU-T H.324 (Video)	64

ITU-T H.321(Video)	384
--------------------	-----

5 UTRAN Delay Components

5.1 General

In this chapter the transmission delay components across the UTRAN are identified and described.

A short description is given for each component, along with affected services and impacting parameters.

5.2 UTRAN Network Components

5.2.1 Macro-diversity Combining Delay

RT **NRT** The Macro Diversity Combination function may require additional switching and processing in the RNC. Even though the delay introduced is heavily implementation-dependent, it has to be considered as a component of the overall delay evaluation.

The MDC function combines signals together at the same moment in time. Therefore, the main delay component in this function is dependent on the difference path delays of each branch involved in a single connection.

5.2.2 Interleaving for Convolutional and Turbo Coding (U3)

RT **NRT** Interleaving is a physical layer function that segments transport blocks over several radio frames. These blocks can be interleaved over 1, 2, 4, and 8 transport blocks. Thus, the interleaving will add a large transmission delay to the data stream over the air interface directly proportional to the interleaving factor.

NRT Turbo coding has its own internal interleaving mechanism, for data services this is an additional delay increasing with the block dimension and decreasing with the service data rate.

For the services envisaged in the present TR the following interleaving factors have been identified:

Application	Interleaving Factor	Turbo-coding applied	Notes
AMR 12.2 kbit/s	2 (20 ms)	No	AMR coder speech blocks: 20 ms [15]
ITU-T H.324 32 kbit/s	2 (20 ms)	Yes	<i>see [15]</i>

ITU-T H.324 64 kbit/s	2 (20 ms)	Yes	see [15]
ITU-T H.321 384 kbit/s	2 (20 ms)	Yes	see [15]

Table 4 : Interleaving for Convolutional and Turbo-coding Delays

5.2.3 MAC Scheduling Delay (U4)

RT For real-time services, a set of resource units will be allocated on a deterministic basis. This implies that a delay no bigger than the transport time interval (TTI) is foreseen. For real time services this is assumed to be 20 ms. The AMR codecs require a data capture time of 20ms [*Editor's note: reference to be provided*], once the data is captured the packet can be forwarded to the RLC for queueing. The MAC-d can instantly send this in a 20ms TTI period to the base-band processing unit. Thus the delay caused by the MAC-d scheduling is offset by codecs on the edge of the network.

NRT Non-real-time services using shared channels require statistical scheduling, the delay introduced may become important, even though delay guarantees will not be applicable. The delay introduced has an impact on acknowledgement delay and on the resulting QoS. The delay caused by the MAC-d multiplexing and by the MAC-sh/c scheduling function is dependent on many variables, for example:

- Load factor of the used resource (direct dependence);
- Traffic source behaviour;
- TTI interval; (direct dependence);
- Peak rate (as measured over a TTI) per connection (direct dependence);;
- Possibly the round trip delay between the UE and the RNC (direct dependence);.

In case a packet has a fixed length TTI period and it will fit into a single TTI interval, the simple M/D/1 analysis can be applied to find a solution.

5.2.4 Re-transmission Delay (U5)

NRT The retransmission of data streams will not take place over real time bearers. When retransmission is used in non-real time services, guaranteed delivery over the radio interface is performed by the RLC. The amount of retransmissions needed for a single transport block is a multiplication factor for delay, i.e. if it takes two re-transmissions to transfer a transport block successfully, then twice the physical layer delay would be added plus the delay needed to send the NAK information back to the MAC:

$$\text{Re-transmission delay} = N_{\text{retransmissions}} * \text{Round trip delay}_{\text{UE-SRNC}}$$

The maximum number of allowed re-transmissions defines the weight introduced by this component according to the following formula:

$$\text{Max Re-transmission Delay} = N_{\text{retransmissionsMax.}} * (\text{ITC} + \text{PPO} + \text{MAC} + \text{MDC} + \text{AAL} + \text{MD} + \text{SD}) * 2.$$

Where:

ITC = Interleaving and Turbo Coding delay

PPO = Packetisation, De-packetisation and End-System Play-Out delay

MAC = MAC Scheduling delay

MDC = Macro-diversity Combining delay

AAL = AAL Packetisation, Multiplexing and De-packetisation delay

MD = Media delay

SD = Switch delay

This delay component can be reduced if prioritisation mechanisms are used for data re-transmission.

5.2.5 Radio Interface Propagation Delay (U6)

Since in one millisecond radio waves cover a distance of around 300 km, the delay introduced by the component can be neglected even considering a macro cell environment.

5.2.6 Processing Delays (U2)

Node internal processing delay is due mainly to SW processing and to information transfer inside nodes. This component has to be considered as the engineered capacity of the network nodes, it is heavily implementation dependent and, therefore, only a rough global evaluation can be given.

- a) AAL2 switching inside a node is a function requiring higher processing effort than simple ATM switching.
AAL2 switching is introduced by S- and DRNCs except on the Iu interface for PS services: in this case AAL2 switching does not take place and the total delay introduced in the SRNC because of this component can be halved.
- b) On the uplink soft- (RNC) and softer (Node B) handover processing introduce further delay, but since the task does not require the execution of complex algorithms, a short processing time can be guessed.
- c) In the downlink the Node B processing consists essentially of CRC calculation, convolutional/turbo-encoding, interleaving, softer handover splitting, spreading and modulation.
- d) In the uplink the processing in Node B is quite different in TDD and FDD, a comparison with GSM is also quite difficult due to the different technology used.
Some of the operations required are quite time consuming even when processing is performed by powerful DSPs: that is why the expected delay to perform the required functions (demodulation,

de-spreading, de-interleaving, convolutional/turbo-decoding, error checking and measurements) is higher than on the downlink side.

- e) .The same considerations reported in d) can be also applied to the UE (by reversing uplink and downlink) with the difference that in a UE problems of power consumption and cost will limit the DSP performance and will show poorer figures.
- f) Internal margins should be considered in every node as a part of the processing delay.

To derive the following figures, [13] has been used as a guideline: from this starting point technological considerations and the above mentioned aspects have been considered to provide the following estimations¹:

- 5 ms for RNC,
- 2 ms for DL Node B,
- 15 ms for UL Node B, no turbo decoding,
- 15 ms + 0.15ms*throughput for UL Node B, with turbo decoding (through put in kbit/s, evaluated by applying Maximum A-posteriori Probability (MAP) algorithm on a state-of-the-art DSP),
- 15 for UL UE,
- 15 ms for DL UE, no turbo decoding
- 20 ms for DL UE with turbo decoding

[Editor's Note: When NRT high speed services will be analysed, the coding time (function of the block length and neglectable for the considered services) shall be also included]

5.3 Transport Network

5.3.1 General

RT **NRT** In this sub-chapter the delay components are described, which are introduced by the transport network interconnecting UTRAN nodes.

To help defining the performance of the transport network, the following delay and bandwidth performance parameters shall be used:

¹ see TSGR3#8(99)e91, Study Item (ARC/3) "Overall Delay Budget within the Access Stratum", Siemens-Italtel and TSGR3#16(00)24, "LS on UE delay requirements for TR 25.932", TSG RAN WG4

- **Packet Transfer Delay (PTD)** defines the elapsed duration between two measurement points. Mean packet transfer delay is the arithmetic average of a specified number of packet transfer delays.
- **Packet Delay Variation (PDV)** is introduced in [8]. Across the AAL2 CPS, a 2-point measurement defines PDV: the 2-point PDV for a packet between two measurement points (MP) is the difference between the absolute packet transfer delay of this packet between the two MPs and a defined reference packet transfer delay between those MPs.
- **Packing density** is defined in [11] and [12] as the ratio of the average user byte number (excluded ATM and CPS headers) in a cell onto the ATM cell length.

In the present evaluation End-to-end PTD and PDV shall be considered: in other words a measurement point shall correspond to one CPS Service Access Point (SAP) at which a CPS-SDU is submitted to the CPS. The second measurement point is localised at the peer SAP delivering CPS-SDU, as shown in Figure 2.

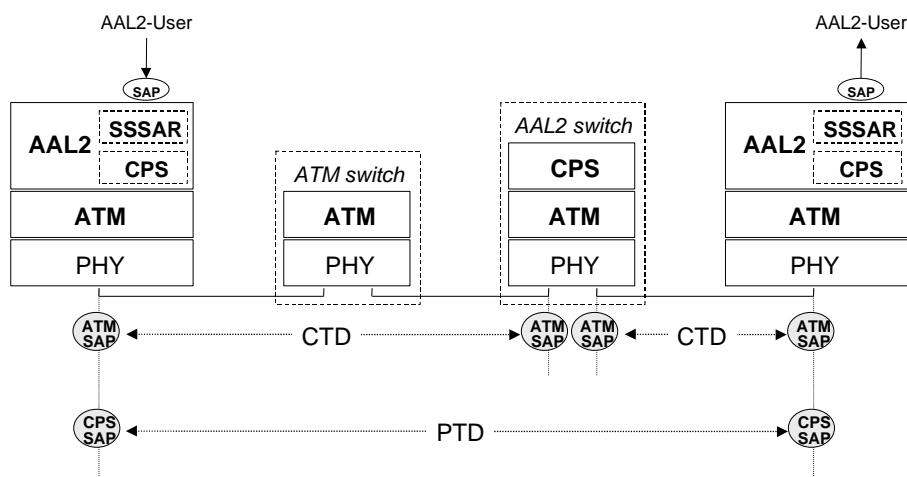

Figure 3 - The differences between CTD and PTD

The packing density results from characteristics of AAL2 user traffic: larger the length of submitted user data is, more significant packing density is. However, there is a theoretical limit of packing density equal to $45/48 \cdot 47/53 \approx 83.14\%$.

Figure 3 depicts the evolution of average packing density according to average length of AAL2 user data (CU_Timer = ∞)

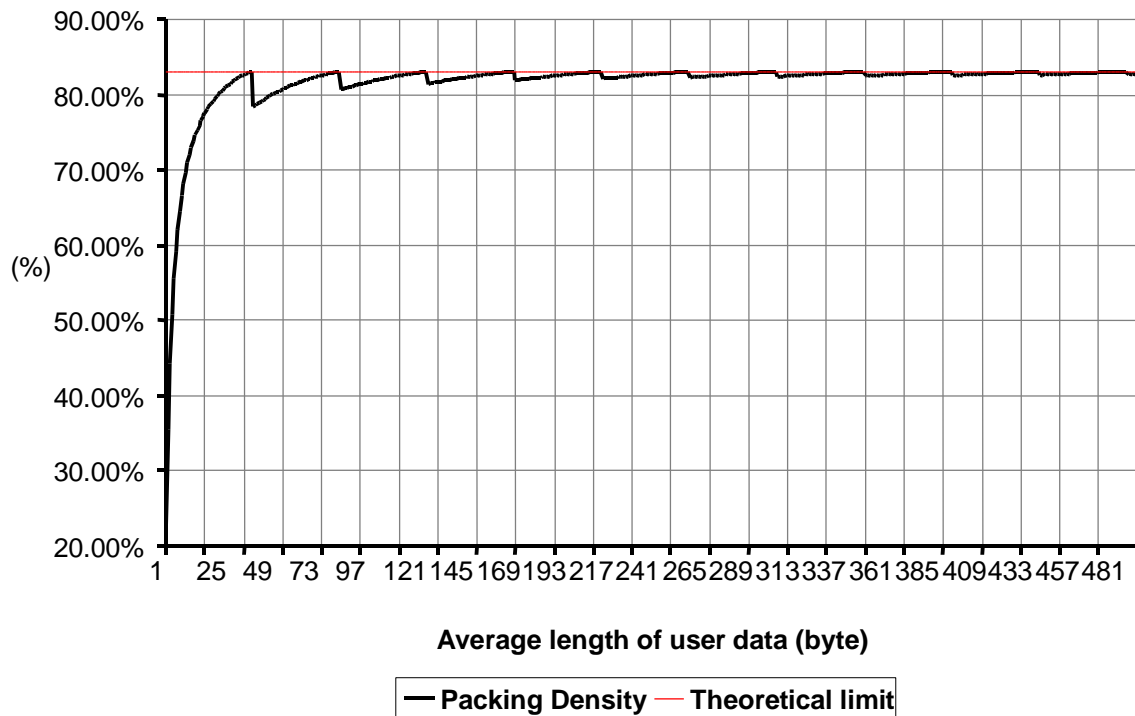

Figure 4 - Evolution of packing density according to average length of user data

According to [10], the CU_Timer_ also affects packing density: if the cell is not completely packed within the time period determined by the CU_Timer_ value, the timer expires and the partially packed cell will be sent.

Consequently, the number of VCs on which AAL2 traffic is distributed can also impact packing density.

In the following figure the relation between packaging density (Efficiency) and CU_Timer value in relation to the bit-rate of the individual sources and the link load is given referred to a 2Mbit/s E1 link. In the representation X/Y, X represents the source bit rate (in kbit/s) and Y represents the link load (as a percentage).

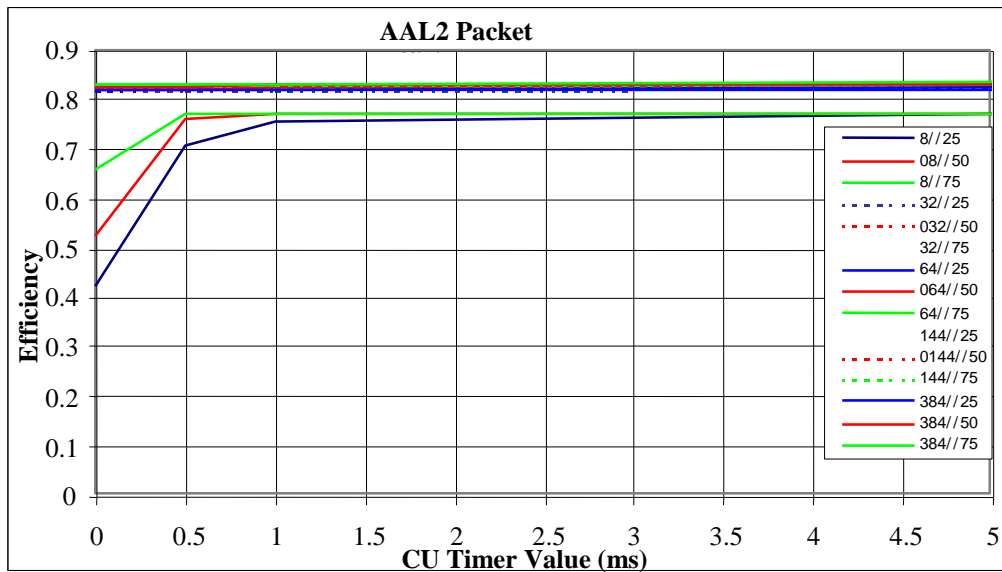

Figure 5: AAL2 Transmission Efficiency²

In the majority of cases the CU timer has little or no effect on the efficiency of an AAL2 link. The exception to this case is the small packet, low bit-rate connections. Low values of the CU Timer show lower efficiencies.

At CU Timer = 0 (cells sent immediately), it can be seen that the load of the AAL2 connection and the connection efficiency are directly proportional.

To derive a precise evaluation of the delay of the transport network, PTD has been split in components, which are outlined and described in the following chapters.

5.3.2 Multiplexing and De-multiplexing Delay (TN1)

RT **NRT** This component, considered on a point-to-point link, is due to the ATM SAR sub-layer action and to the multiplexing of cells and sub-cells (for AAL2) on the ATM link performed in the CPS (Common Part Sub-layer). The PTD and PDV are especially impacted by the *packet queuing delay* in the CPS transmitter buffer. This queuing delay depends on many traffic assumptions and network configuration:

- the individual source's bit-rate (direct dependence);
- the negotiated *QoS of the ATM connection* (especially an increase of the Peak Cell Rate (PCR) decreases the component);
- the *number of active multiplexed AAL2 connections* due to an increase of ATM connection load;
- Considering a low ATM connection load, the *CU_Timer_* value affects the PTD and the PDV in the extent that probability of CU_Timer_ expiration is no null, while for higher loads the CU Timer has no predictable effect on delay performance. Defined in [9], CU_Timer_ is optionally used to ensure that a CPS packet does not wait for a too long time before transmission. Besides, [9] has not specified any value for CU_Timer.

- Due to the CU_Timer_ effects, the *number of selected VCs* to carry AAL2 user data also affects with a direct dependence the AAL2 performance. By distributing AAL2 traffic over several VCs, each ATM connection load decreases (and consequently, probability of Timer_CU expiration increases). Consequently, the PTD and PDV tend to increase.

Moreover, PTD and PDV are impacted by ATM cell queueing at the network switches:

- The data-rate of the physical link and the physical protocol (*IMA upon PDH, SDH, ...*),
- Included in the QoS, the CTD and the CDV of the corresponding ATM connection also affect AAL2 performance.
- The ATM link load obviously impacts AAL2 performance by increasing the delay component.

5.3.3 Play-out Buffer Delay (U1)

Play-out buffering is required to remove the PDV caused by the statistical sharing effects of the packet network. Once this variation is removed and de-packetisation applied, the resulting traffic stream from the protocol stack can be fed to higher layers as a constant stream of data.

Provided that we use the maximum delay component on the link, this component does not introduce further delay.

5.3.4 Transmission Delay

The component represents the delay introduced to transmit completely a single ATM cell.

The transmission delay increases if the net throughput available on the link decreases; the value for some representative links is provided in the following table:

Interface	E1	T1	E3	STM-1	STM-4
Delay	220 μ s	295 μ s	55 μ s	2.5 μ s	0.62 μ s

In this component it is considered the delay introduced by fractional ATM, i.e. by the partitioning of a physical resource into different interfaces. As an example, it could be considered the case of the share of a PCM E1 interface into one Abis interface and one I_{ub} interface, in order to link over a single physical interface a site supporting both GSM and UMTS services.

The delay introduced by this component is inversely proportional to the grade of fractionalisation, in case of an E1 link the component is about:

$$\text{Delay} = \text{Error! } \mu\text{s.}$$

² R3-000134 Packet delay caused by an AAL2 2Mbit/s Link, Siemens

The delay introduced by this component on different interfaces should be reasonably different, since I_{ur} and I_{ub} will be presumably broad band interfaces, while I_{ub} data rate will be smaller, even in case of ring topology.

5.3.5 Media Delay (TN2)

RT **NRT** The propagation delay over cabled networks can be assumed to be fixed and proportional to the connection length.

The same can be assumed for microwave and satellite connections, but to the medium delay a further component must be added, which considers the technology used for the link, e.g. point-to-multipoint, point-to-point, radio ATM.

For satellite links, the delay can be time-dependent, in accordance with the orbit eccentricity .

The following delay can be assumed, according to [5]:

Coax cable: 4 μ s/km;

Optical fibre: 5 μ s/km.

In case μ wave links are used, the following indicative values can be considered (ffs):

PDH microwave link: 1.4 ms

SDH microwave link: 1 ms

Point-to-multipoint microwave link: 5 ms

According to [5] and [6] the delay introduced by a satellite link can range between 60ms (max. value for LEOs) and 310 ms (max. value for HEOs).

It is therefore suggested to allow a single satellite hop along a link over the UTRAN between a UE and the Core Network and to allow a relaxation of the delay expectations.

5.3.6 Switching/and Cross-Connecting Delay (TN3)

RT **NRT** This is the component due to switching nodes (Cross-Connects and Switches) along UTRAN terrestrial interfaces, only. Its value is proportional to the number of intervening nodes and has a heavy direct dependence on the traffic load of each node. [7] defines 300 μ s as the maximum delay for real-time services through ATM switches. Even if the definition of this component is not clear in the quoted reference, this assumption is accepted as a worst case for the pure switching function of an ATM switch/cross-connect.

For the evaluation of the overall delay introduced by an ATM switch/cross-connect the transmission delay will be further considered and added to this component.

6 UTRAN Delay Estimation

6.1 UTRAN Reference Configuration

In the following figure the reference model and branch definitions used in the subsequent evaluation are shown.

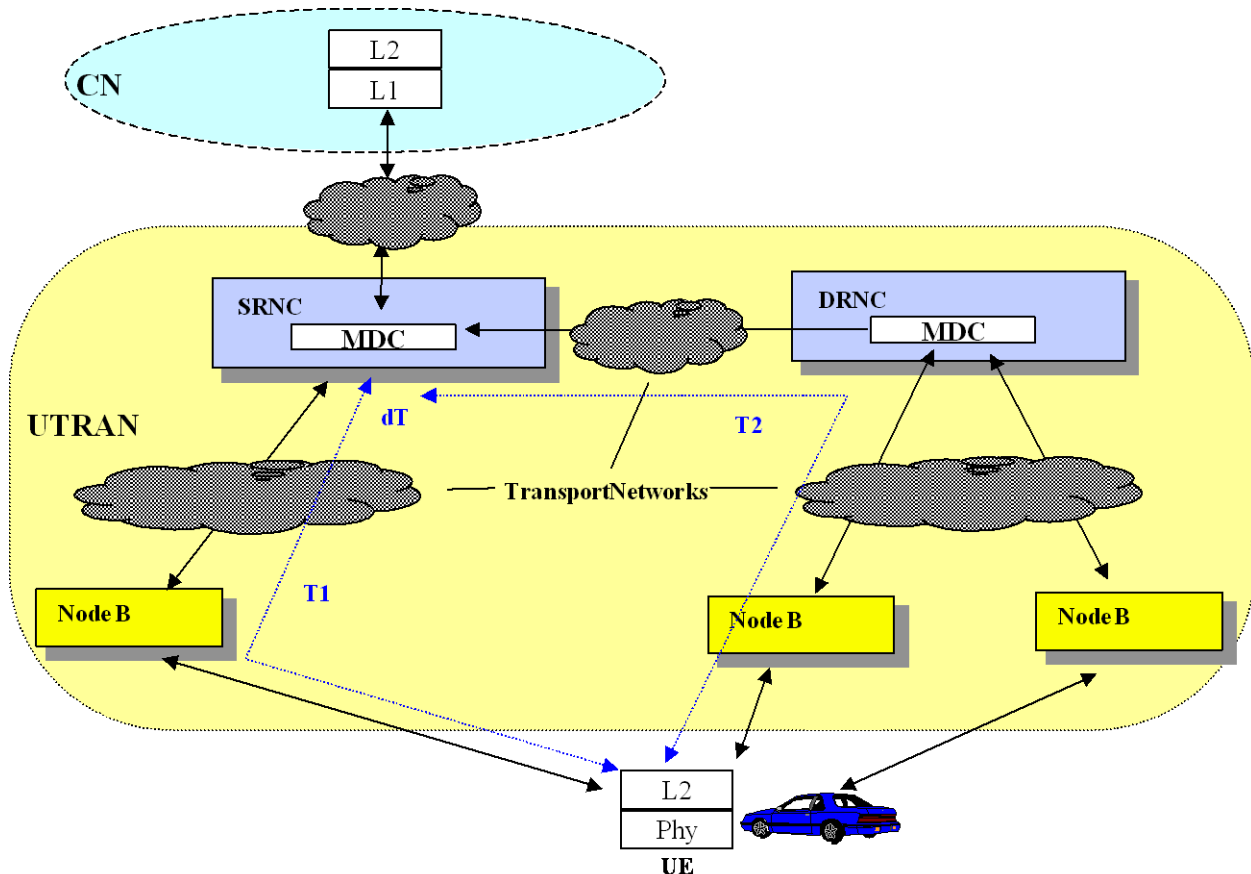

Figure 6 Reference Model and Branch Definition

6.2 Network Assumptions

For the evaluation of delay components introduced by the transport network the following assumptions have been made:

lub interface $T2_{MAX}$: 2-hop PDH μ wave link and 2-hop SDH μ wave link
 50 km per hop
 No fractional ATM applied

lub interface $T1_{MIN}$: Node B and RNC co-located
 No fractional ATM applied

lur interface:	600 km STM-1, optical fibre 4 ATM switches/cross-connects No fractional ATM applied
lu interface:	200 km STM-1, optical fibre 2 ATM switches/cross-connects No fractional ATM applied

6.3 Traffic Assumptions

The following assumptions have been considered to characterise the traffic under analysis³:

Network load:	80%
VCC Peak Cell Rate:	2 Mbit/s
Real Time traffic ¹⁾ :	90%
Real Time traffic model:	Pseudo periodic
Real Time Activity:	100%
QoS handling:	ATM level
Radio Frame boundaries	uniformly distributed on Uu according to 25.402

¹⁾ RT traffic expressed as a fraction of the overall ATM traffic.

6.4 Delay Budget Evaluation

The following figure shows the position of the delay components described previously, considering also the components not included in the Access Stratum, which are considered in Appendix B for the evaluation of the round trip delay.

³ see TSGR3#8(99)e91, Study Item (ARC/3) "Overall Delay Budget within the Access Stratum", Siemens-Italtel

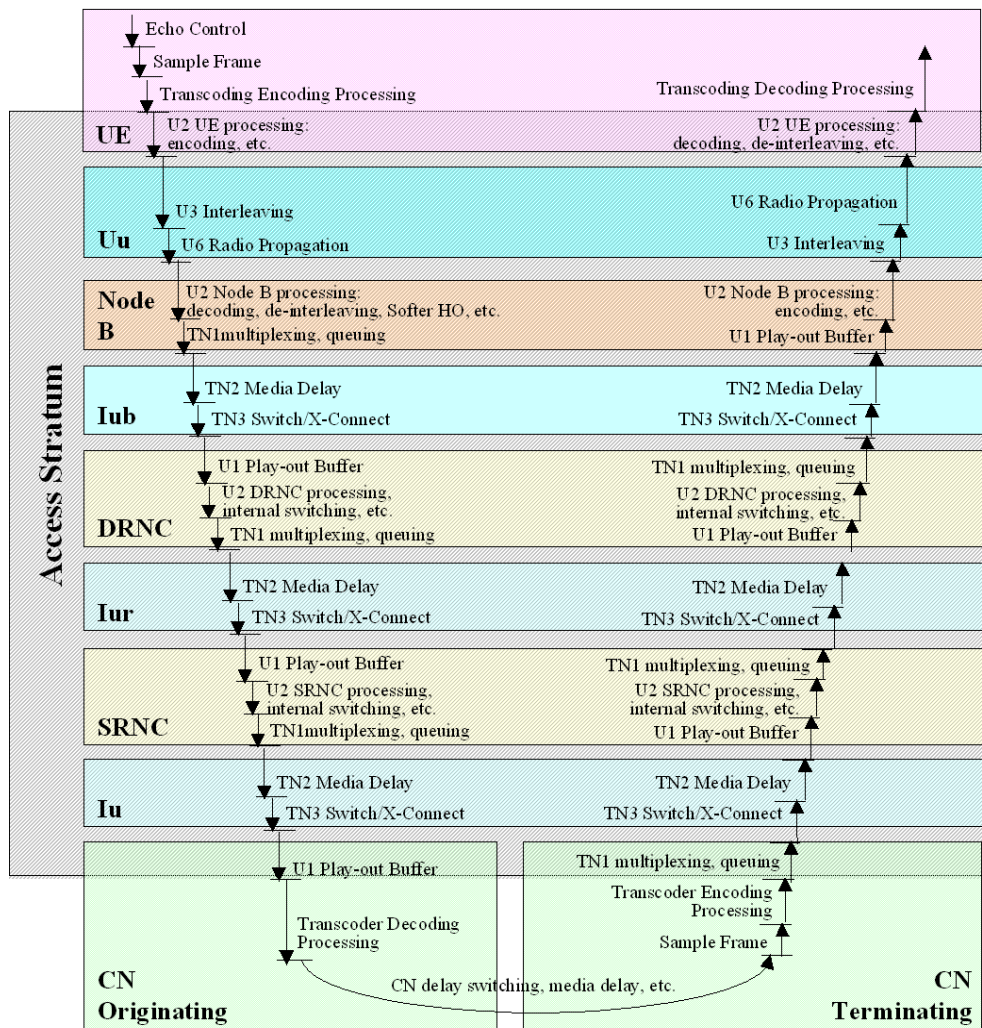

Figure 7 End-to-End Delay Chain

In the following table the delay evaluation summary is reported in a form detailed by component and by Real Time service; the values reported are for downlink, in brackets the uplink figure if different from downlink:

Service (kbit/s)	AMR (12.2)	H.324 (32)	H.324 (64)	H.321 (384)	Notes
Delay Component	Delay (ms)				
T1_{MIN} Branch					
Processing Delay (U2 _{UE})	15(15)	15(15)	15(15)	15(15)	see Ch. 5.2.6
Interleaving Delay (U3)	20	20	20	20	[15], see Ch.5.2.2
Radio Interface Propagation Delay (U6)	0.05				see Ch. 5.2.5

Service (kbit/s)	AMR (12.2)	H.324 (32)	H.324 (64)	H.321 (384)	Notes
Delay Component	Delay (ms)				
Processing Delay ($U_{2\text{NodeB}}$)	2 (15)	2(15)	2(15)	2(15)	see Ch. 5.2.6
Multiplexing and De-multiplexing Delay ($TN_{1\text{Iub}}$)	7	8 ⁴⁾	8 ⁴⁾	8 ⁴⁾	⁴ :- see Ch. 5.3.2
Media Delay ($TN_{2\text{Iub}}$)	0				see Ch.5.3.5
Switch/Cross-connect Node Delay ($TN_{3\text{Iub}}$)	0.2				see Ch. 5.3.6
Processing Delay ($U_{2\text{SRNC}}$)	5	5	5	5	⁵ - see Ch. 5.2.6
Play-out Buffer Delay ($U_{1\text{Iub}}$)	0	0	0	0	see Ch.5.3.3
MAC Scheduling Delay (U_4)	0	0	0	0	see Ch. 5.2.3
Retransmission Delay (U_5)	0	0	0	0	see Ch.5.2.4
$T_{1\text{MIN}}$ Branch Delay	49.2 (62.2)	50.2 (63.2)	50.2 (63.2)	50.2 (63.2)	
$T_{2\text{MAX}}$ Branch					
Processing Delay ($U_{2\text{UE}}$)	15(15)	15(15)	15(15)	15(15)	see Ch. 5.2.6
Interleaving Delay (U_3)	20	20	20	20	[15] – see Ch. 5.2.2
Radio Interface Propagation Delay (U_6)	0.05				see Ch. 5.2.5
Processing Delay ($U_{2\text{NodeB}}$)	2 (15)	2(15)	2(15)	2(15)	see Ch. 5.2.6
Multiplexing and De-multiplexing Delay ($TN_{1\text{Iub}}$)	7	8	8	8	⁶ - see Ch. 5.3.2
Media Delay ($TN_{2\text{Iub}}$)	4.8				see Ch.5.3.5
Switch/Cross-connect Node Delay ($TN_{3\text{Iub}}$)	0.2				see Ch. 5.3.6
Processing Delay ($U_{2\text{DRNC}}$)	5	5	5	5	see Ch. 5.2.6
Play-out Buffer Delay ($U_{1\text{Iub}}$)	0	0	0	0	see Ch.5.3.3

⁴ idem⁵ idem⁶ see TSGR3#8(99)e91, Study Item (ARC/3) "Overall Delay Budget within the Access Stratum", Siemens -Italtel

Service (kbit/s)	AMR (12.2)	H.324 (32)	H.324 (64)	H.321 (384)	Notes
Delay Component	Delay (ms)				
Multiplexing and De-multiplexing Delay (TN1 _{Iur})	5	0.5 ^{*)}	0.5 ^{*)}	0.5 ^{*)}	⁷ see Ch. 5.3.2
Media Delay (TN2 _{Iur})	3				[5] – see Ch. 5.3.5
Switch/Cross-connect Node Delay (TN3 _{Iur})	1.2				[7] – see Ch. 5.3.6
Processing Delay (U2 _{SRNC})	5	5	5	5	see Ch.5.2.6
Play-out Buffer Delay (U1 _{Iur})	0	0	0	0	see Ch.5.3.3
MAC Scheduling Delay (U4)	0	0	0	0	see Ch. 5.2.3
Retransmission Delay (U5)	0	0	0	0	see Ch.5.2.4
T2_{MAX} Branch Delay	68.2 (81.2)	64.7 (77.7)	64.7 (77.7)	64.7 (77.7)	
I_u Interface					
Play-out Buffer Delay (U1 _{Iu})	0	0	0	0	see Ch.5.3.3
Multiplexing and De-multiplexing Delay (TN1 _{Iu})	2	0.5 ^{*)}	0.5 ^{*)}	0.5 ^{*)}	⁸ see Ch.5.3.2
Media Delay (TN2 _{Iu})	1				[5] see Ch.5.3.5
Switch/Cross-connect Node Delay (TN3 _{Iu})	0.6				[7] – see Ch. 5.3.6
I_u Delay	3.6	2.1	2.1	2.1	

^{*)} These values have been derived under conditions not fully compliant with the present assumptions and have been included as a starting point. *[an increase of 50-100% of the time shown could be expected]*

All simulation results evaluated at 10⁻⁵ quantile.

For every service simulations have been performed with a single type of RT traffic source.

Table 5: Evaluation of Delay Components

⁷ see TSGR3#3(99)999 Delay component TN1 (AAL delay), Nokia

⁸ idem

The one-way delay estimation results for Real Time services are reported in the following table; delay definitions are reported below the table (the values reported are for downlink, in brackets the uplink figure).

Service (kbit/s)	AMR (12.2)	H.324 (32)	H.324 (64)	H.321 (384)
One-way Delays	Delay (ms)			
α) T1 _{MIN} delay	49.2 (62.2)	50.2 (63.2)	50.2 (63.2)	50.2 (63.2)
β) T2 _{MAX} delay	71.8 (84.8)	66.8 (79.8)	66.8 (79.8)	66.8 (79.8)
δ) T2 _{MAX} -T1 _{MIN} delay difference	19 (19)	14.5 (14.5)	14.5 (14.5)	14.5 (14.5)
ϵ) SRNC delay	10 (7)	5.5 (5.5)	5.5 (5.5)	5.5 (5.5)
θ) DRNC delay	12 (10)	13 (5.5)	13 (5.5)	13 (5.5)
η) Node B delay	22 (42)	22 (43)	22 (43)	22 (43)

Table 6: One-way Delay Estimation Results

Definitions (with reference to Ch. 6.1 and to Table 5):

α = T1 Min. Branch Delay

β = T2 Max. Branch Delay + Iu Delay

δ = T2 Branch Delay - T1 Branch Delay

The maximum delay difference between T1 and T2 branches has been compared, T1 showing the minimum delay and T2 the maximum.

$$\epsilon_{DL} = U1_{Iu} + U4 + U2_{SRNC} + TN1_{Iur}$$

$$\epsilon_{UL} = U1_{Iur} + U4 + U2_{SRNC} + TN1_{Iu}$$

$$\theta_{DL} = U1_{Iur} + U2_{DRNC} + TN1_{Iub}$$

$$\theta_{UL} = U1_{Iub} + U2_{DRNC} + TN1_{Iur}$$

$$\eta_{DL} = U3 + U2_{NodeB} + U1_{Iub}$$

$$\eta_{UL} = U3 + U2_{NodeB} + TN1_{Iub}$$

7 Bibliography

The following material, though not specifically referenced in the body of the present document (or not publicly available), gives supporting information.

8 Appendix A

8.1 Non Access Stratum Delay Components

To help deriving end-to-end and round-trip delay figures, delay components located outside the UTRAN are reported in the following.

The content of this chapter must be considered purely as a guideline, since outside the scope of the present document.

8.1.1 Transcoding for Speech Services

To encode the speech between time X and time $X+20\text{ms}$, the speech coder needs to gather PCM speech samples from time X to $X+25\text{ms}$ because of the sampling 'look-ahead' function on which it relies. The speech coder also uses information from speech samples gathered before time X , but these do not contribute to delay.

Once all the speech samples have been gathered, processing needs to be performed. This is the delay from time " $X+25$ " to when the whole encoded speech 'packet' is available for transmission.

The collection phase introduces 25 ms delay, while the processing phase is carried out in an implementation and coder dependent time.

The delay quoted in [13] for a full rate coder (8 ms) can be considered as a reference for the UE located function, while more powerful processing could reduce the delay introduced by the TRAU coder to the half (4 ms).

The decoding delay must be calculated between the time when the whole speech frame is in the decoder and when the first sample is made available at the decoder output.

[13] provides a value for this component referred to the full rate decoder, as well. As in the coder case the same value (1.5 ms) can be kept for the UE decoder, while the TRAU located decoder should introduce the half delay (0.8 ms)

As far as concerns the component introduced in TRAU, it must be noted that the worse case occurs when two end UEs engaged in a call are using different codecs and different TRAU: this prevent the support both of TFO (and the optimisation of a back-to-back decoding-coding function) and of TrFO.

8.1.2 Core Network

For speech services: in addition to the delay introduced by the transcoding function, a TRAU introduces a component due to the AAL2 termination/switching (?? ms) plus some further interface and processing delay, in GSM the delay introduced by a MSC according to [13] is 300 μs , the media delay on an E interface (MSC-MSC) of 200 km is 800 μs).

The location of the echo canceller in the CN would introduce a further component dependent on the processing capability available: according to [14] the requirement on this component is 1 ms for the downlink and 0.25 ms for the UL.

For data services transcoding and AAL2 related delays are absent, but more processing must be considered for the GTP-GTP double tunnelling mechanism. The media delay on one Gn interface of 200 km is 800 μ s, to be considered twice being the GGSN the anchor point.

8.1.3 User Equipment

Since the UE delays described in this chapter refer to functions external to the Access Stratum, the present chapter has to be considered as informative.

In addition to the transcoding component already described, some further delay is introduced in the UE for example for the A/D conversion, for the processing and to move speech packets from module to module, in case modules are implemented in different HW components.

A further component is introduced by an echo canceller in case the function is located in the UE.

9 History

Document history		
V0.0.1	2000-02	Initial Specification Structure
V.0.0.2	2000-05	Scope changed to Access Stratum delays References introduced Turbo Coding and decoding delay moved to Processing Delay chapter UTRAN External Delay components moved to appendix Round trip delay evaluation chapter added as appendix editorial improvements and corrections

V.0.0.3	2000-05	<p>Symbols Direct/Inverse proportionality removed and replaced by text</p> <p>Chapter Packetisation, De-packetisation and End-System Play-Out Delay removed</p> <p>Interleaving factor table completed</p> <p>UE Processing Delays added</p> <p>Chapter 'AAL Packetisation,.....' renamed to 'Multiplexing and De-multiplexing Delay'</p> <p>Play-out Buffer Delay chapter introduced</p> <p>Transmission Delay chapter introduced</p> <p>Chapter Delay Components removed</p> <p>Network and Traffic Assumptions modified</p> <p>Figure End-to-end Delay chain added before Delay Budget Estimation table</p> <p>Delay Budget estimation table updated</p> <p>One way Delay Estimation Results table amended</p> <p>Round Trip Delay Evaluation Appendix amended</p>
V.1.0.0	2000-05	<p>Reference to Delay Component abbreviation added in relevant headings in Chapters 5.2 and 5.3</p> <p>Disclaimer introduced</p>
V.1.1.0	2000-08	Appendix B (Round Trip Delay Evaluation) removed
V.2.0.0	2000-10	<p>Chapter 5.2.6 (Processing Delays) updated according to 3GPP RAN WG4 figures</p> <p>Delay Budget figures accordingly updated</p>
Editor for 3GPP RAN TR 25.932 is:		
<p>Massimo Dell'Acqua</p> <p>Siemens Information and Communication Networks</p> <p>Tel.: +39 02 2733 7584</p> <p>Fax : +39 02 2733 7550</p> <p>Email : massimo.dellacqua@icn.siemens.it</p>		
This document is written in Microsoft Word version 97 SR-2.		

Annex A Document Stability Assessment Table

Section	Title	Content missing	Incomplete	Minor corrections needed	Major corrections needed	Minor work required	Major work required	Almost stable	Stable	Comments/Outstanding Issues
1	Scope								√	
2	References								√	
3	Definitions, symbols and abbreviations									
3.1	Definitions								√	Other definitions may be required
3.2	Symbols								√	
3.3	Abbreviations								√	
4	External requirements on UTRAN								√	
5	UTRAN Delay Components								√	
6	UTRAN Delay Estimation									
6.1	UTRAN Reference Configuration								√	
6.2	Network Assumptions								√	
6.3	Traffic Assumptions								√	
6.4	Delay Budget Evaluation							√		
7	Bibliography									No entries
8	Appendix A								√	

Annex B Open Issues relating to this specification

- NRT services' evaluation (release 2000).