

3GPP TR 25.928 V4.0.1 (2001-03)

Technical Report

**3rd Generation Partnership Project;
Technical Specification Group (TSG);
Radio Access Network (RAN);
1.28Mcps functionality for UTRA TDD Physical Layer
(Release 4)**



The present document has been developed within the 3rd Generation Partnership Project (3GPP™) and may be further elaborated for the purposes of 3GPP.

The present document has not been subject to any approval process by the 3GPP Organizational Partners and shall not be implemented. This Specification is provided for future development work within 3GPP only. The Organizational Partners accept no liability for any use of this Specification. Specifications and reports for implementation of the 3GPP™ system should be obtained via the 3GPP Organizational Partners' Publications Offices.

Keywords

3GPP, UTRA, TDD

3GPP

Postal address

3GPP support office address

650 Route des Lucioles - Sophia Antipolis
Valbonne - FRANCE
Tel.: +33 4 92 94 42 00 Fax: +33 4 93 65 47 16

Internet

<http://www.3gpp.org>

Copyright Notification

No part may be reproduced except as authorized by written permission.
The copyright and the foregoing restriction extend to reproduction in all media.

© 2001, 3GPP Organizational Partners (ARIB, CWTS, ETSI, T1, TTA, TTC).
All rights reserved.

Contents

Foreword	8
1 Scope	9
2 References.....	9
3 Abbreviations	9
4 Radio Requirements	9
4.1 Radio environments	9
4.2 Services	9
4.3 Operational requirements	10
4.3.1 Deployment scenarios	10
4.4 Handover and Cell selection/reselection	11
4.5 Particular characteristics of the low chip rate TDD.....	11
5 High level characteristics	12
6 Physical layer - General description.....	13
6.1 General description of Layer 1	13
6.1.2 Service provided to higher layers	13
6.2 Document structure of the physical layer specification	13
6.2.1 Multiple Access.....	13
6.2.2 Channel coding and interleaving	13
6.2.3 Modulation and spreading	13
6.2.4 Physical layer procedures	13
6.2.5 Physical layer measurements	14
7 Physical channels and mapping of transport channels onto physical channels	14
7.1 Transport channels	14
7.1.1 Transport channels.....	14
7.2 Physical channels.....	14
7.2.1 Frame structure.....	14
7.2.2 Dedicated physical channel (DPCH)	15
7.2.2.1 Spreading.....	15
7.2.2.2 Burst Types.....	16
7.2.2.2.1 Transmission of TFCI	17
7.2.2.2.2 Transmission of TPC.....	18
7.2.2.2.3 Timeslot formats	20
7.2.2.2.4 Transmission of SS.....	24
7.2.2.3 Training sequences for spread bursts	27
7.2.2.3.1 Selection of length of channel impulse response	28
7.2.2.4 Beamforming and Transmit Diversity.....	29
7.2.3 Primary common control physical channel (P-CCPCH).....	30
7.2.3.1 Primary common control physical channel (P-CCPCH)	30
7.2.3.1.1 P-CCPCH Spreading	30
7.2.3.1.2 P-CCPCH Burst Types	30
7.2.3.1.3 P-CCPCH Training sequences.....	30
7.2.3.2 Secondary common control physical channel (S-CCPCH)	30
7.2.3.2.1 S-CCPCH Spreading	30
7.2.3.2.2 S-CCPCH Burst Types	31
7.2.3.2.3 S-CCPCH Training sequences.....	31
7.2.3.3 Fast Physical Access CHannel (FPACH)	31
7.2.3.3.1 FPACH burst	31
7.2.3.3.2 Coding of the Forward Physical Access Channel (FPACH) information bits	32
7.2.3.3.3 FPACH Spreading	32
7.2.3.3.4 FPACH Burst Format	32
7.2.3.3.5 FPACH Training sequences.....	32
7.2.3.4 The physical random access channel (PRACH)	32
7.2.3.4.1 PRACH Spreading.....	32

7.2.3.4.2	PRA CH Burst Types	33
7.2.3.4.3	PRA CH Training sequences	33
7.2.3.4.4	Association between Training Sequences and Channelisation Codes	33
7.2.3.5	The synchronisation channel (SCH)	33
7.2.3.6	Physical Uplink Shared Channel (PUSCH)	33
7.2.3.7	Physical Downlink Shared Channel (PDSCH)	33
7.2.3.8	The Page Indicator Channel (PICH)	33
7.2.3.8.1	Mapping of Paging Indicators to the PICH bits	34
7.2.3.8.2	Structure of the PICH over multiple radio frames	34
7.2.4	Beacon function of physical channels	35
7.2.4.1	Location of physical channels with beacon function	35
7.2.4.2	Physical characteristics of the beacon function	35
7.2.5	Midamble Allocation for Physical Channels	35
7.3	Mapping of transport channels to physical channels	35
7.3.1	Dedicated Transport Channels	36
7.3.2	Common Transport Channels	37
7.3.2.1	The Broadcast Channel (BCH)	38
7.3.2.2	The Paging Channel (PCH)	38
7.3.2.2	The Forward Channel (FACH)	38
7.3.2.3	The Random Access Channel (RACH)	38
7.3.2.4	The Uplink Shared Channel (USCH)	39
7.3.2.5	The Downlink Shared Channel (DSCH)	39
8.1	Transport channel coding/multiplexing	39
8.1.1	Error detection	39
8.1.2	Transport block concatenation and code block segmentation	39
8.1.3	Channel coding	39
8.1.3.1	Convolutional Coding	40
8.1.3.2	Turbo coding	40
8.1.3.2.1	Turbo coder	40
8.1.3.2.2	Trellis termination in turbo code	40
8.1.3.2.3	Turbo code internal interleaver	40
8.1.4	Radio frame size equalisation	40
8.1.5	1st interleaving	40
8.1.6	Radio frame segmentation	40
8.1.7	Sub-frame segmentation	40
8.1.8	Rate matching	43
8.1.9	TrCH multiplexing	43
8.1.10	Physical channel segmentation	43
8.1.11	2nd interleaving	43
8.1.11.1	Frame related 2nd interleaving	43
8.1.11.2	Timeslot related 2 nd interleaving	43
8.1.12	Physical channel mapping	43
8.1.12.1	Mapping scheme	44
8.1.13	Multiplexing of different transport channels onto one CCTrCH, and mapping of one CCTrCH onto physical channels	45
8.1.13.1	Allowed CCTrCH combinations for one UE	45
8.1.13.1.1	Allowed CCTrCH combinations on the uplink	45
8.1.13.1.2	Allowed CCTrCH combinations on the downlink	45
8.1.14	Transport format detection	45
8.2	Coding for layer 1 control	45
8.2.1	Coding of transport format combination indicator (TFCI)	45
8.2.1.1	Coding of transport format combination indicator (TFCI) for 8PSK	45
8.2.1.1.1	Coding of long TFCI lengths	46
8.2.1.1.2	Coding of short TFCI lengths	48
8.2.1.1.3	Mapping of TFCI code word	49
8.2.2	Coding of Synchronisation Shift	51
8.2.3	Coding of Transmit Power Control (TPC) [Description:]	51
8.2.4	Coding of the Paging Indicator	52
9	Spreading and Modulation	52
9.1	Data modulation	52

9.1.2	Mapping of bits onto signal point constellation	52
9.1.2.1	QPSK modulation	52
9.1.2.2	8PSK modulation	52
9.1.3	Symbol rate	53
9.2	Spreading modulation	53
9.2.1	Basic spreading parameters	53
9.2.2	Spreading codes.....	53
9.2.3	Scrambling codes	53
9.2.4	Spread and scrambled signal of data symbols and data blocks	53
9.3	Synchronisation codes	53
9.3.1	UpPTS code	54
9.3.2	Code Allocation.....	55
10	Physical layer procedures	63
10.1	Transmitter Power Control	63
10.1.2	Uplink Control	63
10.1.2.1	Common Physical Channel	64
10.1.2.2	Dedicated Physical Channel.....	64
10.1.3	Downlink Control.....	64
10.1.3.1	Common Physical Channel	64
10.1.3.2	Dedicated Physical Channel.....	64
10.2	UL Synchronisation	65
10.2.1	General Description	65
10.2.1.1	Preparation of uplink synchronization (downlink synchronization)	65
10.2.1.2	Establishment of uplink synchronization.....	65
10.2.1.3	Maintenance of uplink synchronisation.....	65
10.2.2	UpPCH	66
10.2.3	PRA CH	66
10.2.4	DPCH and PUSCH	66
10.2.4.1	Out of synchronization handling	66
10.3	Synchronisation and Cell Search Procedures	67
10.3.1	Cell Search	67
10.4	Discontinuous transmission (DTX) of Radio Frames	68
10.5	Downlink Transmit Diversity.....	68
10.5.1	Transmit Diversity for DPCH	68
10.5.1.1	TSTD for DPCH	68
10.5.1.2	Closed Loop Tx Diversity for DPCH	69
10.5.2	Transmit Diversity for DwPCH.....	69
10.5.3	Transmit Diversity for P-CCPCH	70
10.5.3.1	TSTD Transmission Scheme for P-CCPCH	70
10.6	Random Access Procedure	70
10.6.1	Preparation of random access.....	70
10.6.2	Random access procedure.....	71
10.6.2.1	Definitions	71
10.6.2.2	Preparation of random access	71
10.6.2.3	Random access procedure	72
10.6.2.3.1	The use and generation of the information fields transmitted in the FPACH	73
10.6.2.4	Random access collision.....	73
10.6.3	Random access collision	74
11	Physical layer measurements.....	74
11.1	Control of UE/UTRAN measurements.....	74
11.1.1	General measurement concept.....	74
11.1.2	Measurements for cell selection/reselection	74
11.1.3	Measurements for Handover.....	74
11.1.4	Measurements for DCA	74
11.1.5	Measurements for timing advance	74
11.2	Measurement abilities for UTRA TDD	74
11.2.1	UE measurement abilities	74
11.2.1.1	PCCPCH RSCP.....	74
11.2.1.2	CPICH RSCP.....	75
11.2.1.3	RSCP.....	75

11.2.1.4	Timeslot ISCP	75
11.2.1.5	UTRA carrier RSSI	75
11.2.1.6	GSM carrier RSSI.....	75
11.2.1.7	SIR.....	75
11.2.1.8	CPICH Ec/No	75
11.2.1.9	Physical channel BER.....	75
11.2.1.10	Transport channel BLER	75
11.2.1.11	UE transmitted power	75
11.2.1.12	SFN-SFN observed time difference.....	75
11.2.1.13	Observed time difference to GSM cell.....	75
11.2.1.14	Timing Advance (T_{ADV}) for 1.28 Mcps TDD.....	76
Annex A (Normative): Basic Midamble Codes.....		77
A.1	Basic Midamble Codes for Burst Type 1 and PRACH Burst Type.....	77
A.2	Association between Midambles and Channelisation Codes	80
A.2.1	Association for K=16 Midambles	80
A.2.2	Association for K=8 Midambles	81
A.2.3	Association for K=4 Midambles	81
A.2.4	Association for K=2 Midambles	82
A.2.5	Association for K=14 Midambles	82
A.2.6	Association for K=12 Midambles	83
A.2.7	Association for K=10 Midambles	83
A.2.8	Association for K=6 Midambles	84
Annex B (Informative): CCPCH Multiframe Structure.....		85
Annex C (Informative): Examples of the association of DL TPC commands to UL uplink time slots for 1.28 Mcps TDD.....		86
Annex D (Informative): Examples of the association of DL SS commands to UL uplink time slots.....		87
Annex E (informative): Power Control.....		88
E.1	Example Implementation of Closed Loop Uplink Power Control in Node B for 1.28 Mcps TDD.....	88
E.2	Example Implementation of Downlink Power Control in UE for 1.28 Mcps TDD when TSTD is used	88
E.3	Example Implementation of open Loop Power Control for access procedure for 1.28 Mcps TDD.....	88
Annex F (informative): Examples random access procedure for 1.28Mcps TDD		89
F.1	Examples random access procedure for 1.28Mcps TDD.....	89
Annex G (informative): Monitoring GSM from low chip rate TDD: Calculation Results		91
G.1	Low data rate traffic using 1 uplink and 1 downlink slot	91
G.1.1	Higher data rate traffic using more than 1 uplink and/or 1 downlink TDD timeslot.....	92
Annex H: Performance analysis of the low chip rate		94
Annex I: Examples of service mapping		101
I.1	BCH.....	101
I.2	2.4kbps data for downlink.....	103
I.3	12.2kbps data for downlink	104
I.3.1	Example for multiplexing of 12.2 kbps data and 2.4 kbps data	105

I.4 384kbps packet data for downlink 105

I.5 2Mbps packet data for downlink 107

Annex J (informative): Change history..... 109

Foreword

This Technical Report has been produced by the 3rd Generation Partnership Project (3GPP).

The contents of the present document are subject to continuing work within the TSG and may change following formal TSG approval. Should the TSG modify the contents of the present document, it will be re-released by the TSG with an identifying change of release date and an increase in version number as follows:

Version x.y.z

where:

- x the first digit:
 - 1 presented to TSG for information;
 - 2 presented to TSG for approval;
 - 3 or greater indicates TSG approved document under change control.
- y the second digit is incremented for all changes of substance, i.e. technical enhancements, corrections, updates, etc.
- z the third digit is incremented when editorial only changes have been incorporated in the document.

1 Scope

The present document describes the 1.28Mcps functionality for UTRA TDD physical layer, identifies commonalities and explains the differences to the 3.84Mcps chip rate. Suggestions for alignment will be provided too.

2 References

The following documents contain provisions which, through reference in this text, constitute provisions of the present document.

- References are either specific (identified by date of publication, edition number, version number, etc.) or non-specific.
- For a specific reference, subsequent revisions do not apply.
- For a non-specific reference, the latest version applies. In the case of a reference to a 3GPP document (including a GSM document), a non-specific reference implicitly refers to the latest version of that document *in the same Release as the present document*.

- [1] TS 25.201: "Physical Layer - General Description".
- [2] TS 25.221: "Physical channels and mapping of transport channels onto physical channels (TDD)".
- [3] TS 25.222: "Multiplexing and channel coding (TDD)".
- [4] TS 25.223: "Spreading and modulation (TDD)".
- [5] TS 25.224: "Physical layer procedures (TDD)".
- [6] TS 25.225: "Physical layer – Measurements (TDD)".

3 Abbreviations

For the purposes of the present document, the following abbreviations apply:

CDMA	Code Division Multiple Access
PN	Pseudo Noise
QPSK	Quadrature Phase Shift Keying
RACH	Random Access Channel

4 Radio Requirements

4.1 Radio environments

The radio environment recommended by ITU like indoor environment, pedestrian environment, vehicular environment (120km/h) should be well supported by the low chip rate TDD option.

4.2 Services

As one option of TDD mode, the low chip rate option should provide the basic service (bearer service). For a IMT-2000 compliant system corresponding to ITU requirement, for the indoor environment, up to 2Mbps data service should be provided. And for outdoor pedestrian environment, the data service should be up to 384kbps and more. For the UE in moving environment (vehicular speed less than 120km/h), the data rate supported should be 384 and more kbps.

4.3 Operational requirements

The low chip rate TDD option should provide the flexibility to be used for high spot or high density area to provide high speed data service or to provide enhanced coverage or be used alone as macro cell to provide the service coverage. It should allow deployment together with FDD system, with high chip rate TDD system, and be similar as high chip rate TDD deploying with GSM.

4.3.1 Deployment scenarios

For the low chip rate TDD option, the deployment should be flexible for all the scenarios like macro cell, micro cell and pico cell, etc. and also should provide the fixed wireless access.

[Description:]

For the low chip rate TDD option, the deployment should be flexible for all the scenarios like macro cell, micro cell and pico cell, etc. and also should provide the fixed wireless access.

Dependent on the kind of interference accepted by the operator, the operator can vary the max. cell radius in a trade-off with UL - DL interference with the following limitations:

Table 1: Interference scenarios and the corresponding max. cell radius

Case	Max. cell radius
no UpPTS – DwPTS interference allowed	11.25 km
UpPTS – DwPTS interference allowed, but no interference to TS0 allowed	22.5 km
no TS1 – DwPTS interference allowed, other interference allowed	30 km
TS1 – DwPTS interference allowed, but no interference to TS0 allowed	41.25 km

[Rational:]

The guard period of 75 μ s between the DwPTS and the UpPTS is designed to avoid interference between the UpPTS (UL) and the DwPTS (DL). Therefore the cell size ensuring the interference free reception of the DwPTS is guaranteed to a size of approximately 10 km in radius (exact value 11.25 km, assuming no delay spread).

Consequently, for bigger cell radii there is a conflict that the advanced UpPTS interfering the DwPTS reception of another UE being close by.

Even though the UpPTS – DwPTS interference is possible for bigger cell radii than 11.25 km, the impact on the quality of service can be low and acceptable for an operator willing to operate bigger cells.

There are three reasons for that:

The probability that the a UE is close to another UE is low - especially for big cells

The DwPTS needs not to be received by every mobile in every frame. A few DwPTSs being not received during initial cell search mean no big degradation.

The UpPTS is not transmitted every frame it is only needed for random access or handover. So the probability of disturbance is rather low.

It is recommended that the operator avoids interference of TS1 to TS0 by means of the choice of the cell radius. This interference would mean permanent interference for TS0.

The operators can judge the trade-off between quality of service and range and select the range accordingly.

The maximum cell radius d_{\max} is dependent on the time t_{gap} between the potentially interfering UL signal and the potentially interfered DL signal by the following equation:

$$d_{\max} = \frac{c t_{\text{gap}}}{2}; \quad c \text{ is velocity of light.}$$

The following table shows the possible trade-offs between cell radius and interference:

Table 2: Allowed cell radius for the occurrence of the special UL - DL interference

Potentially interfering UL signal	Potentially interfered DL signal	t_{gap} in μs	d_{max} in km
UpPTS	DwPTS	75	11.25
UpPTS	TS0	150	22.5
TS1	DwPTS	200	30
TS1	TS0	275	41.25

[Explanation difference:]

For the high chip rate option there is no DwPTS – guard – UpPTS structure. Here, the UL time slots are following the DL time slots immediately. Thus, there is only one step in degree and quality of interference between DL and UL signals.

For the low chip rate option, it makes a difference in quality and degree whether the DwPTS or TS is interfered by the UpPTS or TS1. Hence the trade-off between cell range and interference is more manifold for the low chip rate option.

4.4 Handover and Cell selection/reselection

The low chip rate TDD option should support the handover between UTRA modes (e.g, low chip rate TDD to high chip rate TDD, low chip rate TDD to FDD), and between systems (e.g. low chip rate TDD to GSM, etc.).

4.5 Particular characteristics of the low chip rate TDD

The features of uplink synchronization, smart antenna (beam forming) etc. have been discussed. These features were agreed to be included in this technical report as they may provide potential performance improvement.

5 High level characteristics

Table 3

Parameter/Feature	Value/Expression	Note
Chip rate	1.28 Mcps	
Modulation	QPSK (8PSK)	
Spreading Factor	1/2/4/8/16	
Nominal Channel Spacing	1.6MHz / Carrier	
Burst Fomat	1 burst type	
Radio Frame Length	10ms (divided into 2 sub-frames)	
Sub-frame length	5ms	
Number of traffic time slots	7	
Time slot length (us)	675	
Downlink pilot slot (us)	75	DwPTS
Uplink pilot slot (us)	125	UpPTS
Guard Period (us)	75	GP After DwPTS
Range of uplink slot	1 – 6	
Range of downlink slot	1 – 6	
Receiver type	Multi-user Detection (option), Rake	
Pilot aided detection	DwPTS, UpPTS, Midamble	
Synchronization aspect	Downlink and uplink synchronization	
Precision for UL sync.	1/8 chip	
Antenna processing	Smart antenna with beam foming	Option
Switching point	Two switching points / sub-frame	
Power control / rate	Open loop power control Closed loop power control / 200Hz (max rate)	
Variable bit rate service	Supported (using TFCI)	
Basic resource unit	One code, one slot with Spreading factor =16 (use of same resource in both consecutive sub-frames)	
Service mapping	Multi-code, multi-slot combination (variable spreading factor)	
Interleaving period	10/20/40/80ms	
HO capability	Low chip rate TDD to High chip rate TDD, FDD, GSM, etc.	
Tx Diversity	same capability as high chip rate TDD for DwPCH,DPCH and P-CCPCH, and TSTD can also be applied to P-CCPCH, DwPCH and DPCH (optional)	Refer to sub clause 10.5 of TR

6 Physical layer - General description

6.1 General description of Layer 1

Common with the high chip rate TDD mode.

6.1.2 Service provided to higher layers

The physical layer offers data transport services to higher layers. The access to these services is through the use of transport channels via the MAC sub-layer. In addition to the functions listed in TS25.201, the physical layer for the low chip rate TDD option is expected to perform the following functions in order to provide the data transport service:

- beamforming;
- synchronisation shift control.

6.2 Document structure of the physical layer specification

6.2.1 Multiple Access

In contrast to the high chip rate TDD option, the access scheme is Direct-Sequence Code Division Multiple Access (DS-CDMA) with information spread over approximately 1.6 MHz bandwidth only, thus also often denoted as low chip rate TDD option due that nature.

The frame structure of the low chip rate options differs from the high chip rate option in the following way: A 10 ms radio frame is divided into 2 sub-frames of 5ms. The frame structure (e.g. switching points) for each sub-frame in the 10ms frame length is the same. The sub-frame is divided into 7 traffic slots (864 chip/slot at the chip rate 1.28 Mcps) as described in subclause 7.2.1 'Frame Structure' and 3 timeslots with special functionality.

The information rate of the channel is different from the high chip rate option and varies with the symbol rate being derived from the 1.28 Mcps chip rate, the spreading factor and the modulation mode.

6.2.2 Channel coding and interleaving

Common with the high chip rate TDD mode

6.2.3 Modulation and spreading

The ordinary modulation scheme is QPSK, as for the the high chip rate option. In addition to that 8PSK is also possible.

For separating different cells the following solutions are additionally supported in the low chip rate option:

- SYNC sequences, SYNC-UL sequences.

For separating different UEs the following code families are additionally defined:

- SYNC-UL sequences

6.2.4 Physical layer procedures

There are several physical layer procedures involved with low chip rate TDD operation that are different and in addition to the high chip rate option. Such procedures covered by physical layer description are:

- 1) The power control, for low chip rate TDD mode close loop control in both uplink and downlink.
- 2) Cell search operation.
- 3) Uplink synchronisation for low chip rate TDD mode.

- 4) Random access
- 5) Beamforming (optional)

6.2.5 Physical layer measurements

Common with the high chip rate TDD mode

[Explanation difference to section 6]

Most of the physical characters of the low chip rate TDD option are same as the high chip rate TDD option. But due to the different operation frequency band width and some other different implementation consideration such as power control method, uplink synchronization, there still exist some difference and all these differences will be discussed in the main part of TR25.928.

7 Physical channels and mapping of transport channels onto physical channels

7.1 Transport channels

7.1.1 Transport channels

'Common with the high chip rate TDD mode'

7.2 Physical channels

7.2.1 Frame structure

[Description:]

For low chip rate option, the frame length is 10ms and the 10ms frame is divided into 2 sub-frames of 5ms. The frame structure for each sub-frame in the 10ms frame length is the same.

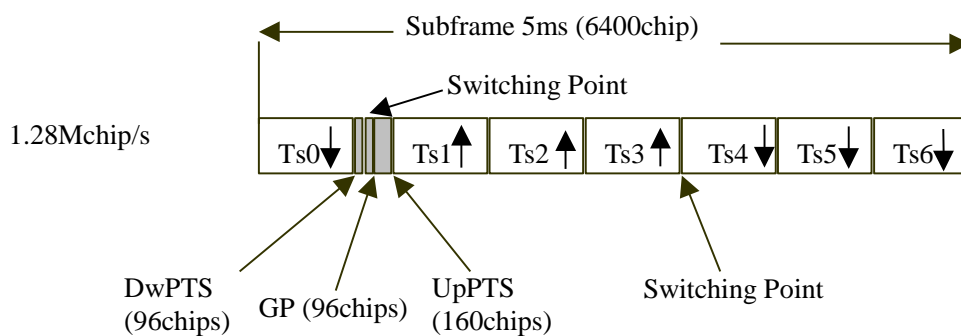

Figure 1: Structure of the sub-frame for low chip rate option

The frame structure for each sub-frame is shown in Figure above.

Ts_n (n from 0 to 6): the nth traffic time slot, 864 chips duration;

DwPTS: downlink pilot time slot, 96 chips duration;

UpPTS: uplink pilot time slot, 160 chips duration;

GP: main guard period for TDD operation, 96 chips duration;

[Rationale:]

In the figure above, the total number of traffic timeslots for uplink and downlink is 7, and the length for each traffic timeslot is 864 chips duration. Among the 7 traffic timeslot, Ts#0 is always allocated as downlink while Ts#1 is always allocated as uplink. The time slots for the uplink and the downlink are separated by a switching point. Between the downlink time slots and uplink time slots, the special period is the switching point to separate the uplink and downlink. In each sub-frame of 5ms for low chip rate option, there are two switching points (uplink to downlink and vice versa). The proposed frame structure has taken some new technologies into consideration, either the smart antenna (beam forming) technology or the uplink synchronisation will be well supported.

Using the above frame structure, the low chip rate TDD option can operate on both symmetric and asymmetric mode by properly configuring the number of downlink and uplink time slots; (note that whatever the time slot configuration will be, the GP and DwPTS position within the frame should not change in order not to desynchronise the UEs and in order to allow Node B on air synchronisation procedures which make use of the DwPCH!) . It should be noted that in asymmetric operation mode, at least one traffic uplink time slot and one downlink time slot will be allocated for traffic (Ts#0 for downlink and Ts#1 for uplink). The guard period GP of 96 chips can support the cell radius of up to about 11 km for uplink synchronization operation where the uplink transmission is advanced in macro-, micro- and pico- cell of small cells in cities or large cells in rural areas. Here the GP insures that an UE transmitting the UpPTS does not disturb the reception of the DwPTS for other UEs being close by. If this distortion is accepted in the network the cell radius can be bigger. (Note that the UpPTS is not continuously transmitted and the DwPTS is not continuously received.)

The only difference to the last version of the frame structure proposal for low chip rate is the improving of the numbering of the time slots. The physical layer behaviour does not change.

[Explanation of difference:]

For both high chip rate option and low chip rate option, the frame length is 10 ms , But for low chip rate option the 10 ms length is divided into 2 sub-frame of 5 ms to allow the fast update of power control, uplink synchronization, and smart antenna beamforming.

For high chip rate option , each 10 ms frame consists of 15 time slots, each allocated to either the uplink or the downlink . So it has both single and multiple-switching point configuration both for symmetric and asymmetric allocation. While in the low chip rate option, the position of the big Guard Period GP and of the DwPTS and UpPTS physical channels, is always between Ts0 and Ts1 whatever the level of asymmetry be.

7.2.2 Dedicated physical channel (DPCH)

7.2.2.1 Spreading

'Common with the high chip rate TDD mode'

7.2.2.2 Burst Types

[Description:]

In correspondence to the frame structure described above, the burst structures for Tsn, DwPTS and UpPTS are proposed. The burst structure for traffic time slot (Ts#n) is described in Figure below.

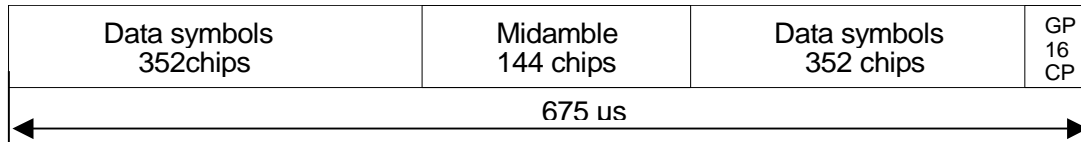

Figure 2: Burst structure for traffic time slot

The structure for DwPTS and UpPTS is described in Figures below.

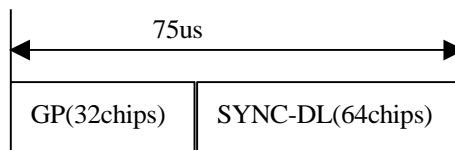

Figure 3: Structure for DwPTS

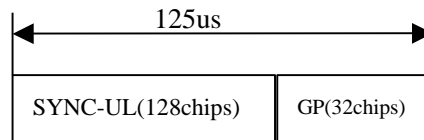

Figure 4: Structure for UpPTS

[Rationale:]

In the burst structure figure, the data symbols in each side of the midamble are 352 chips. The TPC bits for power control, the TFCI bits and the additional uplink synchronization bits (synchronization shift) are included in the Data symbols fields of the burst if they are needed. The amount of TFCI bits used is depending on the service and the details for TFCI, synchronization shift and TPC bits should be provided later with service mapping. For the power control symbols, the uplink synchronization control symbols and the TFCI the symbols around the midamble are used.

The GP field in the same figure for each time slot is used for protection between time slots to avoid the long delay multi-path interference. It should be noted that the GP of the TS0 together with the guard period in DwPTS is 48 chips long which is different with other normal guard period of 16 chips between time slots. This 'super long' guard period can be used to avoid the interference between the last downlink traffic time slot and the downlink synchronization pilot burst. Otherwise, the interference to the last downlink time slot from the strong powered pilot will be serious to the traffic; and vice versa, the interference to the downlink pilot burst from the last downlink time slot will decrease the performance on downlink synchronization and cell search. Note that if the UEs serving Node B is far away and the UE makes handover measurements it will receive the beginning of the DwPTS of a close by Node B inside these 48 chip. 48 chip corresponds to 11 km difference in distance to the Node B. If the other Node B is more distant to the serving Node B, big guard period can be used for receiving the DwPTS of the handover candidate Node B.

In DwPTS and UpPTS, the content of SYNC-DL and SYNC-UL field are used for downlink and uplink pilot. The GP fields are used to separate the downlink (uplink) pilot from the traffic downlink (uplink) time slot.

It should be pointed out that the uplink synchronization burst (SYNC-UL) is not followed by a RACH immediately. First the UL synchronization burst UpPTS is sent by the UE. This UpPTS is used for Node B to determine the received power level and the received timing. Second, the Node B transmits timing and power control information to the UE using the FPACH (one burst message) within the next 4 sub-frames. Then the P-RACH is transmitted. The FPACH is carrying single burst messages transmitted on a traffic time slot (see Burst structure figure). This two phase procedure which is different with the GSM of one phase procedure has better performance than the classical approach as used in GSM. In this case, the traffic burst and access burst can be active in the same time slot and the interference is reduced for each other if they are time-aligned.

Note that the UpPTS has to be transmitted by the UE in advance (starting in the big GP) to arrive at the Node B at the position indicated in the burst structure figure. The UpPTS can also be received at a different position if the UE cannot or does not aim at the RX position indicated in the burst structure figure. Thus, the UpPTS can also start within the guard interval (RX, TX), depending on the situation in the system. This means relaxation to estimate timing in UE, e.g. from pathloss on P-CCPCH.

And the proposed frame structure can support all the environments of macro-, micro- and pico- cells. In vehicular environment, the speed can be more than 120km/h. Also in the proposed frame structure, some specific properties for low chip rate option such as smart antenna technology, uplink synchronisation, beamforming, etc can be well supported.

[Explanation difference:]

In high chip rate option, there are 2 burst types of DPCH. They have different midamble lengths. And there is only one burst type of DPCH in the low chip rate option. The use of the same burst structure for RACH and for traffic will guarantee that the RACH can be handled with conventional traffic on the same UL time slots since the RACH is already UL synchronised.

7.2.2.2.1 Transmission of TFCI

[Description:]

There is only one burst type for traffic time slot in the low chip rate option. It provides the possibility for transmission of TFCI both in up- and downlink. For every user the TFCI information is to be transmitted once per 10ms radioframe. If no TPC and SS are applied, the TFCI information is to be transmitted directly adjacent to the midamble of the 5ms subframe of the assigned frame. The position in case of TPC and/or SS application is shown in the figures below.

[Rationale:]

There is only one burst type for traffic time slot in the low chip rate option. It provides the possibility for transmission of TFCI both in up- and downlink. For every user the TFCI information is to be transmitted once per 10ms radioframe. The transmission of TFCI is negotiated at call setup and can be re-negotiated during the call. For each CCTrCH it is indicated by higher layer signalling, which TFCI format is applied. Additionally for each allocated timeslot it is signalled individually whether that timeslot carries the TFCI or not. If a time slot contains the TFCI, then it is always transmitted using the first allocated channelisation code in the timeslot, according to the order in the higher layer allocation message. The transmission of TFCI is done in the data parts of the respective physical channel, this means

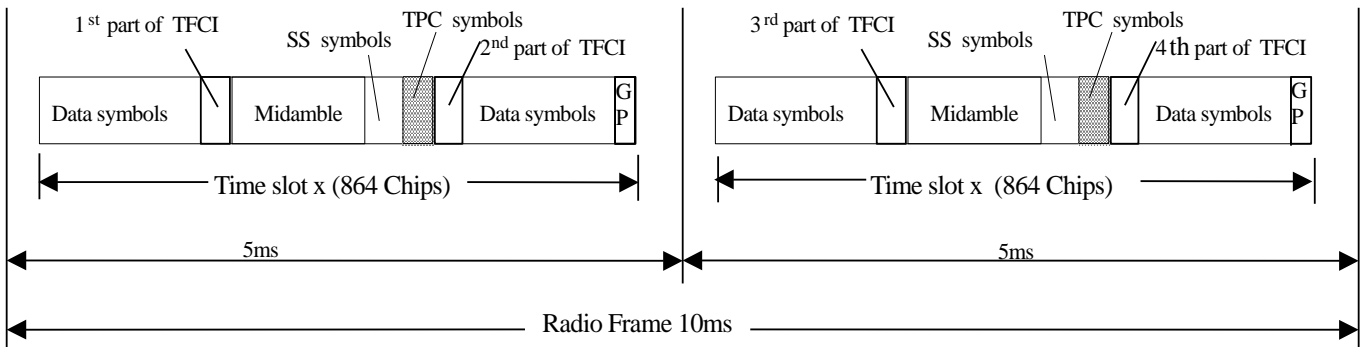

Position of TFCI information in the traffic burst in case of L1 control signals

TFCI and data bits are subject to the same spreading procedure. The encoded TFCI symbols are both equally distributed between the subframes and between the data blocks. Hence the midamble structure and length is not changed. If no TPC and SS are applied, the TFCI information is to be transmitted directly adjacent to the midamble of the 5ms subframe of the assigned frame. The position in case of TPC and/or SS application is shown in the figures above. Figure above shows the position of the TFCI in a traffic burst, if L1 control signals, SS (synchronization shift) and TPC (Transmit Power Control), is transmitted.

[Explanation difference:]

In high chip rate option, both burst types 1 and 2 provide the possibility for transmission of TFCI both in up- and downlink. The TFCI information is to be transmitted directly adjacent to the midamble if no TPC is transmitted. In the low chip rate option, there is only one burst type for traffic time slot. It provides the possibility for transmission of TFCI

both in up- and downlink. For every user the TFCI information is to be transmitted once per 10ms radioframe. The TFCI information is to be transmitted directly adjacent to the midamble of the 5ms subframe of the assigned frame if no TPC and SS is applied. The position of the TFCI in case of TPC and/or SS transmission is analogous to the high chiprate option and depicted in figure above.

7.2.2.2.2 Transmission of TPC

[Description:]

There is only one burst type for traffic time slot in the low chip rate option. It provides the possibility for transmission of L1 control signal "TPC" both in up- and downlink. For every user the TPC information is to be transmitted once per 5ms subframe.

[Rational:]

The burst type for dedicated channels provides the possibility for transmission of TPC in uplink and downlink.

The transmission of TPC is done in the data parts of the traffic burst. Hence the midamble structure and length is not changed. The TPC information is to be transmitted directly after the SS information, which is transmitted after the midamble. Figure 5 shows the position of the TPC command in a traffic burst.

For every user the TPC information is to be transmitted at least once per 5ms sub-frame. If applied, transmission of TPC is done in the data parts of the traffic burst and it can be transmitted using the first allocated channelisation code and the first allocated timeslot (according to the order in the higher layer allocation message). Other allocations (more than one TPC transmission in one sub-frame) of TPC are also possible. The TPC is spread with the same spreading factor (SF) and spreading code as the data parts of the respective physical channel.

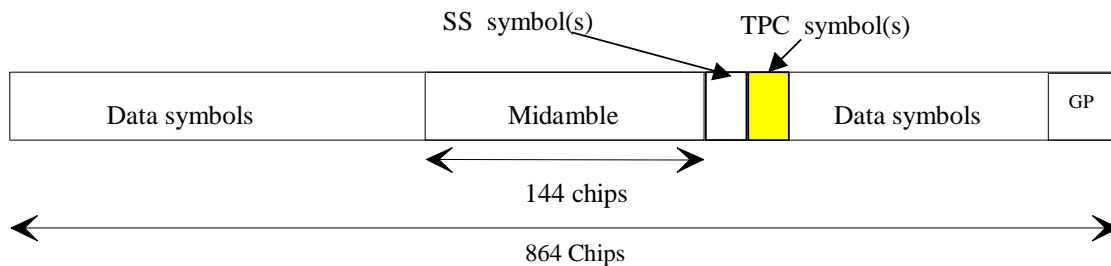

Figure 5: Position of TPC information in the traffic burst in downlink and uplink

For the number of layer 1 symbols per channelisation code there are 3 possibilities for each channelisation code, configured by higher layers:

- 1) one SS and one TPC symbol
- 2) no SS and no TPC symbols
- 3) 16/SF SS and 16/SF TPC symbols

So, in case 3), when SF=1, there are 16 TPC symbols which correspond to 32 bits (for QPSK) and 48 bits (for 8PSK).

In the following the uplink is described only. For the description of the downlink, downlink (DL) and uplink (UL) have to be interchanged.

Each of the TPC symbols for uplink power control in the DL will be associated with an UL time slot and an UL CCTrCH pair. This association varies with

- the number of allocated UL time slots and UL CCTrCHs on these time slots (time slot and CCTrCH pair) and
- the allocated TPC symbols in the DL.

In case a UE has

more than one channelisation code

and/or

channelisation codes being of lower spreading factor than 16 and using 16/SF SS and 16/SF TPC symbols,

the TPC commands for each ULtime slot CCTrCH pair (all channelisation codes on that time slot belonging to the same time slot and CCTrCH pair have the same TPC command) will be distributed to the following rules:

1. The ULtime slots and CCTrCH pairs the TPC commands are intended for will be numbered from the first to the last ULtime slot and CCTrCH pair allocated to the regarded UE (starting with 0). The number of a time slot and CCTrCH pair is smaller than the number of another time slot and CCTrCH pair within the same time slot if its spreading code with the lowest SC number according to the following table has a lower SC number than the spreading code with the lowest SC number of the other time slot and CCTrCH pair.
2. The commanding TPC symbols on all DL CCTrCHs allocated to one UE are numbered consecutively starting with zero according to the following rules:
 - a) The numbers of the TPC commands of a regarded DL time slot are lower than those of DL time slots being transmitted after that time slot
 - b) Within a DL time slot the numbers of the TPC commands of a regarded channelisation code are lower than those of channelisation codes having a higher spreading code number

The spreading code number is defined by the following table (see[8]):

Table 4

SC number	SF (Q)	Walsh code number (k)
0	16	$c_{Q=16}^{(k=1)}$
	...	
15	16	$c_{Q=16}^{(k=16)}$
16	8	$c_{Q=8}^{(k=1)}$
	...	
23	8	$c_{Q=8}^{(k=8)}$
24	4	$c_{Q=4}^{(k=1)}$
	...	
27	4	$c_{Q=4}^{(k=4)}$
28	2	$c_{Q=2}^{(k=1)}$
29	2	$c_{Q=2}^{(k=2)}$
30	1	$c_{Q=1}^{(k=1)}$

Note: Spreading factors 2-8 are not used in DL

- c) Within a channelisation code numbers of the TPC commands are lower than those of TPC commands being transmitted after that time

The following equation is used to determine the UL time slot which is controlled by the regarded TPC symbol in the DL:

$$UL_{pos} = (SFN' \cdot N_{UL_TPCsymbols} + TPC_{DLpos}) \bmod(N_{ULslot}),$$

where

$N_{UL_{pos}}$ is the number of the controlled uplink time slot and CCTrCH pairs.

SFN' is the system frame number counting the sub-frames. The system frame number of the radio frames (SFN) can be derived from SFN' by

$SFN = SFN' \text{ div } 2$, where div is the remainder free division operation.

$N_{UL_{PCsymbols}}$ is the number of UL TPC symbols in a sub-frame.

$TPC_{DL_{pos}}$ is the number of the regarded UL TPC symbol in the DL within the sub-frame.

$N_{UL_{slot}}$ is the number of UL slots and CCTrCH pairs in a frame.

In Annex G two examples of the association of TPC commands to time slots and CCTrCH pairs are shown.

Coding of TPC: The relationship between the TPC Bits and the transmitter power control command for QPSK is the same as in the 3.84Mcps TDD cf. [5.2.2.5 'Transmission of TPC'].

The relationship between the TPC Bits and the transmitter power control command for 8PSK is given in table 5.

Table 5: TPC Bit Pattern for 8PSK

TPC Bits	TPC command	Meaning
000	'Down'	Decrease Tx Power
110	'Up'	Increase Tx Power

[Explanation difference:]

In high chip rate option, both burst types 1 and 2 provide the possibility for transmission of TPC only in uplink.

While in the low chip rate option, there is only one burst type for traffic time slot. For the number of layer 1 symbols there are 3 possibilities configurable for each channelisation code during the call setup. It provides the possibility for transmission of TPC both in up- and downlink. For every user the TPC information is to be transmitted once per 5ms subframe. So it gives faster power control functionality in the low chip rate option than it does in high chip rate option. This is advantageous, because the lower chip rate has less frequency diversity which can be compensated with faster control algorithms. The smart antenna feature increases the demand on the speed of the control algorithms, because the smart antenna algorithms tend to focus on one DOA which has more Rayleigh fading than all DOAs received at a single antenna.

7.2.2.2.3 Timeslot formats

[Description:]

The timeslot format depends on the spreading factor, midamble length, the TPC and SS signals presence and on the number of the TFCI bits. In the case that L1 signals is used, different amount of bits are mapped to the two data fields. For the transmission of the TPC/SS, there are three possible configurations for the number of TPC/SS symbols:

1. 1 symbol TPC and 1 symbol SS
2. No TPC and No SS.
3. 16/SF symbol TPC and 16/SF symbol SS.

So, in case 3, when SF=1, the number of TPC/SS is 16 symbol corresponding 32 bits (for QPSK) and 48 bits (for 8PSK).

16/SF TPC/SS symbols is for the case that the number of L1 signalling bits of one given RU after spreading are same although different SFs are used. Thus, the mapping of user data on the payload can stay the same regardless what the spreading factor is.

The timeslot formats are depicted in the following subclause.

7.2.2.2.3.1

Timeslot formats for Downlink

Table 6: Time slot formats for the Downlink

Slot Format #	Spreading Factor	Midamble length (chips)	N _{TFCI} (bits)	N _{SS} & N _{TPC} (bits)	Bits/slot	N _{Data/Slot} (bits)	N _{data/data field(1)} (bits)	N _{data/data field(2)} (bits)
0	16	144	0	0 & 0	88	88	44	44
1	16	144	4	0 & 0	88	86	42	44
2	16	144	8	0 & 0	88	84	42	42
3	16	144	16	0 & 0	88	80	40	40
4	16	144	32	0 & 0	88	72	36	36
5	16	144	0	2 & 2	88	84	44	40
6	16	144	4	2 & 2	88	82	42	40
7	16	144	8	2 & 2	88	80	42	38
8	16	144	16	2 & 2	88	76	40	36
9	16	144	32	2 & 2	88	68	36	32
10	1	144	0	0 & 0	1408	1408	704	704
11	1	144	4	0 & 0	1408	1406	702	704
12	1	144	8	0 & 0	1408	1404	702	702
13	1	144	16	0 & 0	1408	1400	700	700
14	1	144	32	0 & 0	1408	1392	696	696
15	1	144	0	2 & 2	1408	1404	704	700
16	1	144	4	2 & 2	1408	1402	702	700
17	1	144	8	2 & 2	1408	1400	702	698
18	1	144	16	2 & 2	1408	1396	700	696
19	1	144	32	2 & 2	1408	1388	696	692
20	1	144	0	32 & 32	1408	1344	704	640
21	1	144	4	32 & 32	1408	1342	702	640
22	1	144	8	32 & 32	1408	1340	702	638
23	1	144	16	32 & 32	1408	1336	700	636
24	1	144	32	32 & 32	1408	1328	696	632

7.2.2.2.3.2

Timeslot formats for Uplink

Table 7: Time slot formats for the Uplink

Slot Format #	Spreading Factor	Midamble length (chips)	N _{TFCI} (bits)	N _{ss} & N _{TFC} (bits)	Bits/slot	N _{Data/Slot} (bits)	N _{data/data field(1)} (bits)	N _{data/data field(2)} (bits)
0	16	144	0	0 & 0	88	88	44	44
1	16	144	4	0 & 0	88	86	42	44
2	16	144	8	0 & 0	88	84	42	42
3	16	144	16	0 & 0	88	80	40	40
4	16	144	32	0 & 0	88	72	36	36
5	16	144	0	2 & 2	88	84	44	40
6	16	144	4	2 & 2	88	82	42	40
7	16	144	8	2 & 2	88	80	42	38
8	16	144	16	2 & 2	88	76	40	36
9	16	144	32	2 & 2	88	68	36	32
10	8	144	0	0 & 0	176	176	88	88
11	8	144	4	0 & 0	176	174	86	88
12	8	144	8	0 & 0	176	172	86	86
13	8	144	16	0 & 0	176	168	84	84
14	8	144	32	0 & 0	176	160	80	80
15	8	144	0	2 & 2	176	172	88	84
16	8	144	4	2 & 2	176	170	86	84
17	8	144	8	2 & 2	176	168	86	82
18	8	144	16	2 & 2	176	164	84	80
19	8	144	32	2 & 2	176	156	80	76
20	8	144	0	4 & 4	176	168	88	80
21	8	144	4	4 & 4	176	166	86	80
22	8	144	8	4 & 4	176	164	86	78
23	8	144	16	4 & 4	176	160	84	76
24	8	144	32	4 & 4	176	152	80	72
25	4	144	0	0 & 0	352	352	176	176
26	4	144	4	0 & 0	352	350	174	176
27	4	144	8	0 & 0	352	348	174	174
28	4	144	16	0 & 0	352	344	172	172
29	4	144	32	0 & 0	352	336	168	168
30	4	144	0	2 & 2	352	348	176	172
31	4	144	4	2 & 2	352	346	174	172
32	4	144	8	2 & 2	352	344	174	170
33	4	144	16	2 & 2	352	340	172	168
34	4	144	32	2 & 2	352	332	168	164
35	4	144	0	8 & 8	352	336	176	160
36	4	144	4	8 & 8	352	334	174	160
37	4	144	8	8 & 8	352	332	174	158
38	4	144	16	8 & 8	352	328	172	156
39	4	144	32	8 & 8	352	320	168	152
40	2	144	0	0 & 0	704	704	352	352
41	2	144	4	0 & 0	704	702	350	352
42	2	144	8	0 & 0	704	700	350	350
43	2	144	16	0 & 0	704	696	348	348
44	2	144	32	0 & 0	704	688	344	344
45	2	144	0	2 & 2	704	700	352	348
46	2	144	4	2 & 2	704	698	350	348

Slot Format #	Spreading Factor	Midamble length (chips)	N _{TFCI} (bits)	N _{SS} & N _{TPC} (bits)	Bits/slot	N _{Data/Slot} (bits)	N _{data/data field(1)} (bits)	N _{data/data field(2)} (bits)
47	2	144	8	2 & 2	704	696	350	346
48	2	144	16	2 & 2	704	692	348	344
49	2	144	32	2 & 2	704	684	344	340
50	2	144	0	16 & 16	704	672	352	320
51	2	144	4	16 & 16	704	670	350	320
52	2	144	8	16 & 16	704	668	350	318
53	2	144	16	16 & 16	704	664	348	316
54	2	144	32	16 & 16	704	656	344	312
55	1	144	0	0 & 0	1408	1408	704	704
56	1	144	4	0 & 0	1408	1406	702	704
57	1	144	8	0 & 0	1408	1404	702	702
58	1	144	16	0 & 0	1408	1400	700	700
59	1	144	32	0 & 0	1408	1392	696	696
60	1	144	0	2 & 2	1408	1404	704	700
61	1	144	4	2 & 2	1408	1402	702	700
62	1	144	8	2 & 2	1408	1400	702	698
63	1	144	16	2 & 2	1408	1396	700	696
64	1	144	32	2 & 2	1408	1388	696	692
65	1	144	0	32 & 32	1408	1344	704	640
66	1	144	4	32 & 32	1408	1342	702	640
67	1	144	8	32 & 32	1408	1340	702	638
68	1	144	16	32 & 32	1408	1336	700	636
69	1	144	32	32 & 32	1408	1328	696	632

7.2.2.2.3.3 Timeslot formats for 8PSK modulation (both for Uplink and Downlink)

Table 8: Timeslot formats for 8PSK modulation (uplink and downlink)

Slot Format #	Spreading Factor	Midamble length (chips)	N _{TFCI} (bits)	N _{SS} & N _{TPC} (bits)	Bits/slot	N _{Data/Slot} (bits)	N _{data/data field(1)} (bits)	N _{data/data field(2)} (bits)
0	1	144	0	0 & 0	2112	2112	1056	1056
1	1	144	6	0 & 0	2112	2109	1053	1056
2	1	144	12	0 & 0	2112	2106	1053	1053
3	1	144	24	0 & 0	2112	2100	1050	1050
4	1	144	48	0 & 0	2112	2088	1044	1044
5	1	144	0	3 & 3	2112	2106	1056	1050
6	1	144	6	3 & 3	2112	2103	1053	1050
7	1	144	12	3 & 3	2112	2100	1053	1047
8	1	144	24	3 & 3	2112	2094	1050	1044
9	1	144	48	3 & 3	2112	2082	1044	1038
10	1	144	0	48 & 48	2112	2016	1056	960
11	1	144	6	48 & 48	2112	2013	1053	960
12	1	144	12	48 & 48	2112	2010	1053	957
13	1	144	24	48 & 48	2112	2004	1050	954
14	1	144	48	48 & 48	2112	1992	1044	948
15	16	144	0	0 & 0	132	132	66	66
16	16	144	6	0 & 0	132	129	63	66
17	16	144	12	0 & 0	132	126	63	63
18	16	144	24	0 & 0	132	120	60	60
19	16	144	48	0 & 0	132	108	54	54
20	16	144	0	3 & 3	132	126	66	60
21	16	144	6	3 & 3	132	123	63	60
22	16	144	12	3 & 3	132	120	63	57
23	16	144	24	3 & 3	132	114	60	54
24	16	144	48	3 & 3	132	102	54	48

[Explanation difference:]

Based on the burst structure and the TFCI,SS and TPC control signals, the low chip rate TDD option has a different burst type from that of high chip rate TDD option.

7.2.2.2.4 Transmission of SS

[Description:]

The SS is utilized to command a timing adjustment each M frame. The SS, as one of L1 signals, is to be transmitted once per 5ms subframe in downlink.

[Rationale:]

The burst type for dedicated channels provides the possibility for transmission of uplink synchronisation control (ULSC).

The transmission of ULSC is done in the data parts of the traffic burst. Hence the midamble structure and length is not changed. The ULSC information is to be transmitted directly after the midamble. Figure 6 shows the position of the SS command in a traffic burst.

For every user the ULSC information shall be transmitted at least once per transmitted sub-frame. By default the following rules apply:

1. If TFCI is applied for a CCTrCH, the SS command(s) shall be transmitted using the same channelisation code and the same timeslots as the TFCI.
2. If no TFCI is applied for a CCTrCH, the SS command(s) shall be transmitted using the first allocated channelisation code and the first allocated timeslot, according to the order in the higher layer allocation message.

Apart from the default rules other allocations of SS commands are possible according higher layer signalling – e.g. the transmission of more than one SS command (on more than one time slot).

The SS command is spread with the same spreading factor (SF) and spreading code as the data parts of the respective physical channel.

The SS is utilised to command a timing adjustment by $(k/8)T_c$ each M sub-frames, where T_c is the chip period. The default k and M values are signalled by the network by means of system information that is broadcast in the cell. The SS, as one of L1 signals, is to be transmitted once per 5ms sub-frame.

M (1-8) and k (1-8) can be adjusted during call setup or readjusted during the call.

Note: The smallest step for the SS signalled by the UTRAN is $1/8 T_c$. For the UE capabilities regarding the SS adjustment of the UE it is suggested to set the tolerance for the executed command to be $[1/9; 1/7] T_c$.

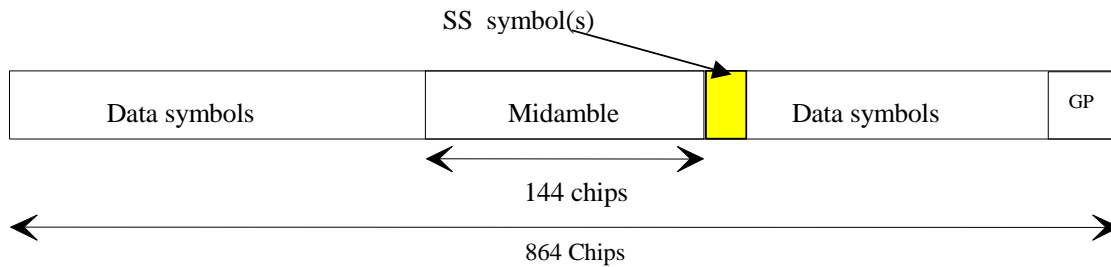

Figure 6: Position of ULSC information in the traffic burst (downlink and uplink)

Note that for the uplink where there's no SS symbol used, the SS symbol space is reserved for future use. This can keep UL and DL slots the same structure.

For the number of layer 1 symbols there are 3 possibilities configurable for each channelisation code during the call setup:

- one SS symbol
- no SS symbol
- $16/SF$ SS symbols

So, in case 3, when $SF=1$, there are 16 SS symbols which correspond to 32 bits (for QPSK) and 48 bits (for 8PSK).

Each of the SS symbols in the DL will be associated with an UL time slot depending on the allocated UL time slots and the allocated SS symbols in the DL.

Note: Even though the different time slots of the UE are controlled with independent SS commands, the UE is not in need to execute SS commands leading to a deviation of more than [3] chip with respect to the average timing advance applied by the UE.

The synchronisation shift commands for each UL time slot (all channelisation codes on that time slot have the same SS command) will be distributed to the following rules:

1. The UL time slots the SS commands are intended for will be numbered from the first to the last UL time slot occupied by the regarded UE (starting with 0) considering all CCTrCHs allocated to that UE.
2. The commanding SS symbols on all downlink CCTrCHs allocated to one UE are numbered consecutively starting with zero according to the following rules:
 - a) The numbers of the SS commands of a regarded DL time slot are lower than those of DL time slots being transmitted after that time slot
 - b) Within a DL time slot the numbers of the SS commands of a regarded channelisation code are lower than those of channelisation codes having a bigger spreading code number

The spreading code number is defined by the following table: (see TS 25.223)

Table 9

Spreading code number	SF (Q)	Walsh code number (k)
0	16	$c_{Q=16}^{(k=1)}$
	...	
15	16	$c_{Q=16}^{(k=16)}$
	Spreading factors 2-8 are not used in DL	
30	1	$c_{Q=1}^{(k=1)}$

- c) Within a channelisation code numbers of the SS commands are lower than those of SS commands being transmitted after that time

The following equation is used to determine the UL time slot which is controlled by the regarded SS symbol:

$$UL_{pos} = (SFN' \cdot N_{SSsymbols} + SS_{pos}) \bmod (N_{ULslot}),$$

where

UL_{pos} is the number of the controlled uplink time slot.

SFN' is the system frame number counting the sub-frames. The system frame number of the radio frames (SFN) can be derived from SFN' by

$SFN = SFN' \text{ div } 2$, where div is the remainder free division operation.

$N_{SSsymbols}$ is the number of SS symbols in a frame.

SS_{pos} is the number of the regarded SS symbol within the sub-frame.

N_{ULslot} is the number of UL slots in a frame.

[Explanation difference:]

In high chip rate TDD option, SS information is not transmitted as L1 signal on each frame. Because of uplink synchronization in the low chip rate TDD option, SS information is transmitted in downlink, as one of L1 signals, once per 5ms subframe.

7.2.2.3 Training sequences for spread bursts

[Description:]

The training sequences, i.e. midambles, of different users active in the same time slot are time shifted versions of a single periodic basic code. Different cells use different periodic basic midamble codes, i.e. different midamble sets. In this way joint channel estimation for the channel impulse responses of all active users within one time slot can be done by one single cyclic correlation. The different user specific channel impulse response estimations are obtained sequentially in time at the output of the correlator.

Up to 16 midambles are possible within the low chip rate TDD option.

The generation of midamble is different from high chip rate TDD option. The difference of training sequences for spread bursts for low chip rate is described here.

[Rationale:]

The burst structure for low chip rate TDD option is different with high chip rate TDD option. These bursts contain L_m midamble chips, which are also termed midamble elements. The L_m elements $\underline{m}_i^{(k)}$; $i=1\dots L_m$; $k=1,\dots,K$; of the midamble codes $\underline{\mathbf{m}}^{(k)}$; $k=1,\dots,K$; of the K users are taken from the complex set

$$\underline{\mathbf{V}}_m = \{1, j, -1, -j\}. \quad (1)$$

The elements $\underline{m}_i^{(k)}$ of the complex midamble codes $\underline{\mathbf{m}}^{(k)}$ fulfil the relation

$$\underline{m}_i^{(k)} = (j)^i \cdot m_i^{(k)} \quad m_i^{(k)} \in \{1, -1\}; i = 1, \dots, L_m; k = 1, \dots, K. \quad (2)$$

Hence, the elements $\underline{m}_i^{(k)}$ of the complex midamble codes $\underline{\mathbf{m}}^{(k)}$ of the K users are alternating real and imaginary.

With W being the number of taps of the impulse response of the UE radio channels, the L_m binary elements $m_i^{(k)}$; $i = 1, \dots, L_m$; $k = 1, \dots, K$; of (2) for the complex midamble $\underline{\mathbf{m}}^{(k)}$; $k=1,\dots,K$; of the K users are generated according to Steiner's method [1] from a single periodic basic code

$$\mathbf{m} = (m_1, m_2, \dots, m_{L_m+(K-1)W})^T \quad m_i \in \{1, -1\}; i = 1, \dots, (L_m + (K-1)W). \quad (3)$$

The elements m_i ; $i = 1, \dots, (L_m + (K-1)W)$, of (3) fulfil the relation

$$m_i = m_{i-P} \text{ for the subset } i = (P+1), \dots, (L_m + (K-1)W). \quad (4)$$

The P elements m_i ; $i = 1, \dots, P$, of one period of \mathbf{m} according to (3) are contained in the vector

$$\mathbf{m}_P = (m_1, m_2, \dots, m_P)^T. \quad (5)$$

With \mathbf{m} according to (3) the L_m binary elements $m_i^{(k)}$; $i = 1, \dots, L_m$; $k = 1, \dots, K$; of (2) for the midamble of the K users are generated based on Steiner's formula

$$m_i^{(k)} = m_{i+(K-k)W} \quad i = 1, \dots, L_m; k = 1, \dots, K. \quad (6)$$

In the following the term 'a midamble code set' or 'a midamble code family' denotes K specific midamble codes $\underline{\mathbf{m}}^{(k)}$; $k=1,\dots,K$. Different midamble code sets $\underline{\mathbf{m}}^{(k)}$; $k=1,\dots,K$; are in the following specified based on different periods \mathbf{m}_P according (5).

In adjacent cells of the cellular UE radio system, different midamble codes sets $\underline{\mathbf{m}}^{(k)}$; $k=1,\dots,K$; should be used to guarantee a proper channel estimation.

As mentioned above a single midamble code set $\underline{\mathbf{m}}^{(k)}$; $k=1,\dots,K$; consisting of K midamble codes is based on a single period \mathbf{m}_P according to (5).

In the following several exemplary periods \mathbf{m}_P according (5) which can be used to generate different midamble code sets $\underline{\mathbf{m}}^{(k)}$; $k=1,\dots,K$; will be listed in tables in a hexadecimal representation. As shown in the table below always 4 binary elements m_i are mapped on a single hexadecimal digit.

Table 10: Mapping of 4 binary elements on a single hexadecimal digit

4 binary elements m_i	Mapped on hexadecimal digit
-1 -1 -1 -1	0
-1 -1 -1 1	1
-1 -1 1 -1	2
-1 -1 1 1	3
-1 1 -1 -1	4
-1 1 -1 1	5
-1 1 1 -1	6
-1 1 1 1	7
1 -1 -1 -1	8
1 -1 -1 1	9
1 -1 1 -1	A
1 -1 1 1	B
1 1 -1 -1	C
1 1 -1 1	D
1 1 1 -1	E
1 1 1 1	F

The mean degradation's which serve as a quality information of the periods \mathbf{m}_P according to (5) and hence of the specified midamble code sets $\underline{\mathbf{m}}^{(k)}$; $k=1,\dots,K$; will be also given.

[Explanation difference:]

The midamble used in the burst for low chip rate TDD is different from high chip rate TDD. And this is mainly coming from different chip rate and burst format. Different chip rate lead to different length of channel impulse response and the different length of training sequence (midamble).

The maximum channel impulse response is scalable. This evokes a different midamble generation scheme as used for high chip rate TDD.

7.2.2.3.1 Selection of length of channel impulse response

[Description:]

The training sequences, i.e. Midambles, of different users active in the same slot are time shifted versions of one single periodic basic code. Different cells use different periodic basic codes, i.e. different midamble sets. In this way a joint channel estimation for the channel impulse responses of all active users within one time slot can be done by one single cyclic correlation. The different user specific channel impulse response estimates are obtained sequentially in time at the output of the correlator. Up to 16 midambles in one time slot are possible within the low chip rate TDD option.

In both low and high chip rate systems, W , the length of the impulse response of the mobile radio channels, is an important parameter. There is only one burst type for traffic time slot in the low chip rate TDD option, and the length of midambles is different from the high chip rate option, so the selection of W needs to be defined separately.

[Rational:]

The midamble has a length of $L_m=144$, which is corresponding to:

$$K=2, 4, 6, 8, 10, 12, 14, 16, W=\left\lfloor \frac{P}{K} \right\rfloor, P=128.$$

Note: that $\lfloor x \rfloor$ denotes the largest integer number less or equal to x .

Depending on the possible delay spread cells are configured to use midambles which are generated from the Basic Midamble Codes.

The cell configuration is broadcast on BCH.

7.2.2.4 Beamforming and Transmit Diversity

[Description:]

A smart antenna system is composed of an array of multiple antenna elements and coherent transceivers with advanced digital signal processing algorithms. Instead of a single fixed beam pattern from a traditional antenna, the smart antenna can dynamically generate multiple beam patterns, each of them is pointed to a particular UE, and such beam patterns can adapt to follow any UE intelligently. On the Rx side of Node B, such a feature, i.e., spatial selective reception at the Node B can greatly minimize co-channel interference from the co-channel UEs at different locations, thus increase the Rx sensitivity and lead to higher capacity. It can also effectively incorporate multipath components to combat multipath fading. On the Tx side of Node B, intelligent spatially selective Tx (downlink) beamforming can also greatly reduce the interference to other co-channel UEs, then dramatically save the output power requirement and lead to higher capacity. It should be noted that this section only describes a preferred approach to beamforming, other high performance techniques may also be applicable.

The low chip rate option is mainly based on the smart antenna technology. Some main technical features of the low chip rate TDD option such as 5 ms sub-frame structure are based on the smart antenna request.

When DL beamforming or TX Diversity is used, at least for the resource units beamforming/Tx Diversity is applied to and which are allocated to dedicated channels, the resource units shall get one individual midamble per user or per resource unit according to midamble generation, even in DL.

[Rationale:]

The smart antenna array is composed of N antenna elements, N related feed cables and N coherent RF transceivers in RF part. By use of the A/D converters or D/A converters in analog baseband (ABB), the Rx and Tx analog signals are interfaced to the digital baseband (DBB) part over the high-speed data bus. In this model, all antenna elements related feed cables and coherent RF transceivers will be calibrated before operating.

Beamforming

For the Node B is equipped with smart antenna array and DBB DSP, when a signal comes from one UE within the coverage of the Node B, each antenna element and coherent RF receiver will get it. Because of the different location of the different antenna element, the phase of the Rx signal will be different. In case of multipath propagation, each path will come from different directions with different amplitude and delay. Then the Rx signal at each antenna element will show different phase and amplitude. After the front-end processing in RF part and A/D converters processing in ABB, digitized Rx signal with the phase and amplitude information will be sent to DSP in DBB part. After despreading in the DBB processor, the Rx data of each code channel may be obtained. The purpose of smart antenna in uplink is to find the best E_b/I_0 after the combination. Theoretically, spatial reception at Node B can add up all useful signals while canceling all multipath interference. The next step is to realise downlink beamforming. The Tx signal of the each code channel is got by some algorithms that enable the UE to obtain the best E_b/I_0 . In TDD system, because of the symmetrical performance in wave propagation, it is possible to directly use the spatial reception at Node B results to downlink beamforming.

Fast beamforming

It is always very important to reach fast beamforming to catch the time variation in mobile network. The Node B should have a in-time reaction to the fast changing beam patterns. And this is the reason that the TDD interval in low chip rate option is 5ms while 10ms in high chip rate option. This value is a compromise in considering both the number of time slots and the switching speed of RF components.

In smart antenna system, the BTS need receive the UpLink data first, then decide the UE's position, and then beamform to UE in Downlink, but the UE does not need to transmit regularly for the Node B to determine the antenna weights when it is in idle mode.

[Explanation difference:]

For high chip rate option, the chapter about beamforming already exists.

Like the high chip rate option is that not only each user can get one midamble but also each resource allocated to that user can (but need not to) get an individual midamble. The benefit of this is that the signalling overhead is reduced.

7.2.3 Primary common control physical channel (P-CCPCH)

7.2.3.1 Primary common control physical channel (P-CCPCH)

The BCH as described in subclause 'Common Transport Channels' is mapped onto the Primary Common Control Physical Channels (P-CCPCH1 and P-CCPCH2). The position (time slot / code) of the P-CCPCHs is fixed in the 1.28Mcps TDD. The P-CCPCHs are mapped onto the first two code channels of timeslot#0 with spreading factor of 16, see subclause 'Common Transport Channels'. The P-CCPCH is always transmitted with an antenna pattern configuration that provides whole cell coverage.

7.2.3.1.1 P-CCPCH Spreading

The P-CCPCH uses fixed spreading with a spreading factor $SF = 16$. The P-CCPCH1 and P-CCPCH2 always use channelisation code $C_{Q=16}^{(k=1)}$ and $C_{Q=16}^{(k=2)}$ respectively.

7.2.3.1.2 P-CCPCH Burst Types

Only one burst type in low chip rate option. No TFCI is applied for the P-CCPCH.

7.2.3.1.3 P-CCPCH Training sequences

The training sequences, i.e. midambles, as described in the subclause on midamble generation are used for the P-CCPCH. The basic midamble code $m^{(1)}$ is used for P-CCPCHs as training sequence.

[Explanation difference:]

There are two kinds of burst types in high chip option and the burst type 1 is used for the P-CCPCH.

There is only one burst type in the low chip rate option. In order to make the same capacity available, 2 codes with SF16 are used for the P-CCPCH. The coding of the BCH is 1/3, because the usage of 2 codes allows more efficient coding.

7.2.3.2 Secondary common control physical channel (S-CCPCH)

PCH and FACH are mapped onto one or more secondary common control physical channels (S-CCPCH). In this way the capacity of PCH and FACH can be adapted to the different requirements. The time slot and codes used for the S-CCPCH are broadcast on the BCH.

7.2.3.2.1 S-CCPCH Spreading

The S-CCPCH uses fixed spreading with a spreading factor $SF = 16$. The S-CCPCHs (S-CCPCH 1 and S-CCPCH 2) are always used in pairs, mapped onto two code channels with spreading factor 16. There can be more than one pair of S-CCPCHs in use in one cell.

7.2.3.2.2 S-CCPCH Burst Types

Same burst type as for the P-CCPCH. TFCI may be applied for S-CCPCHs.

7.2.3.2.3 S-CCPCH Training sequences

The training sequences, i.e. midambles as described in the MA-generation chapter, are used for the S-CCPCH.

7.2.3.3 Fast Physical Access CHannel (FPACH)

The Fast Physical Access CHannel (FPACH) is used by the Node B to carry, in a single burst, the acknowledgement of a detected signature with timing and power level adjustment indication to a user equipment. FPACH makes use of one resource unit only at spreading factor 16, so that its burst is composed by 44 symbols. The spreading code, training sequence and time slot position are configured by the network and signalled on the BCH.

7.2.3.3.1 FPACH burst

The FPACH burst contains 32 information bits.

Table 11 reports the content description of the FPACH information bits and their priority order.

Table 11: FPACH information bits description

Information field	Length (in bits)
Signature Reference Number	3 (MSB)
Relative Sub-Frame Number	2
Received starting position of the UpPCH (UpPCH _{POS})	11
Transmit Power Level Command for RACH message	7
Reserved bits (default value: 0)	9 (LSB)

7.2.3.3.1.1 Signature Reference Number

The reported number corresponds to the numbering principle for the cell signatures as described in sub-clause 9.3. The Signature Reference Number value range is 0 – 7 coded in 3 bits such that:

bit sequence(0 0 0) corresponds to the first signature of the cell; ...; bit sequence (1 1 1) corresponds to the 8th signature of the cell.

7.2.3.3.1.2 Relative Sub-Frame Number

The Relative Sub-Frame Number value range is 0 – 3 coded such that:

bit sequence (0 0) indicates one sub-frame difference; ...; bit sequence (1 1) indicates 4 sub-frame difference.

7.2.3.3.1.3 Received starting position of the UpPCH (UpPCH_{POS})

The received starting position of the UpPCH value range is 0 – 2047 coded such that:

bit sequence (0 0 ... 0 0 0) indicates the received starting position zero chip; ...; bit sequence (1 1 ... 1 1 1) indicates the received starting position 2047* 1/8 chip.

7.2.3.3.1.4 Transmit Power Level Command for the RACH message

The transmit power level command is transmitted in 7 bits.

7.2.3.3.2 Coding of the Forward Physical Access Channel (FPACH) information bits

The FPACH burst is composed by 32 information bits which are block coded and convolutional coded, and then delivered in one sub-frame as follows:

1. The 32 information bits are protected by 8 parity bits for error detection as described in sub-clause 4.2.1.1.
2. Convolutional code with constraint length 9 and coding rate $\frac{1}{2}$ is applied as described in sub-clause 4.2.3.1. The size of data block $c(k)$ after convolutional encoder is 96 bits.
3. To adjust the size of the data block $c(k)$ to the size of the FPACH burst, 8 bits are punctured as described in sub-clause 4.2.7 with the following clarifications:
 - $N_{i,j}=96$ is the number of bits in a radio sub-frame before rate matching
 - $\Delta N_{i,j} = -8$ is the number of bits to punctured in a radio sub-frame
 - $e_{ini} = a \times N_{ij}$

The 88 bits after rate matching are then delivered to the intra-frame interleaving.

4. The bits in input to the interleaving unit are denoted as $\{x(0), \dots, x(87)\}$. The coded bits are block rectangular interleaved according to the following rule: the input is written row by row, the output is read column by column.

$$\begin{bmatrix} x(0) & x(1) & x(2) & \dots & x(7) \\ x(8) & x(9) & x(10) & \dots & x(15) \\ \vdots & \vdots & \vdots & \dots & \vdots \\ x(80) & x(81) & x(82) & \dots & x(87) \end{bmatrix}$$

Hence, the interleaved sequence is denoted by $y(i)$ and are given by:

$$y(0), y(1), \dots, y(87) = x(0), x(8), \dots, x(80), x(1), \dots, x(87).$$

7.2.3.3.3 FPACH Spreading

The FPACH uses only spreading factor $SF=16$. The set of admissible spreading codes for use on the FPACH are broadcast on the BCH (within the FPACH configuration parameters on the BCH).

7.2.3.3.4 FPACH Burst Format

The burst format as described in section 7.2.2.2 is used for the FPACH.

7.2.3.3.5 FPACH Training sequences

The training sequences, i.e. midambles, of different users active in the same time slot are time shifted versions of a single periodic basic code. The basic midamble codes as described in the subclause about midamble generation are used for FPACH.

7.2.3.4 The physical random access channel (PRACH)

The RACH is mapped onto one or more uplink physical random access channels (PRACH). In such a way the capacity of the RACH can be flexibly scaled depending on the operators need.

7.2.3.4.1 PRACH Spreading

The uplink PRACH uses either spreading factor $SF=16$ or $SF=8$ or $SF=4$ as described in subclause 6.2.1. The set of admissible spreading codes for use on the PRACH and the associated spreading factors are broadcast on the BCH (within the RACH configuration parameters on the BCH).

7.2.3.4.2 PRACH Burst Types

The burst type used on the PRACH is the same as for a traffic channel.

7.2.3.4.3 PRACH Training sequences

The training sequences, i.e. midambles, of different users active in the same time slot are time shifted versions of a single periodic basic code. The basic midamble codes as described in subclause about midamble generation are used for PRACH.

7.2.3.4.4 Association between Training Sequences and Channelisation Codes

The association between training sequences and channelisation codes of PRACH in the 1.28McpsTDD is same as that of the DPCH.

[Explanation difference:]

In subclause 10.6.2 "random access procedure", it has been mentioned that the random access procedure of low chip rate option has two-step approach. The SYNC-UL word is used to carry out uplink synchronisation and to resolve the access collision. This two-step procedure enables the PRACH to be transmitted with high synchronisation precision as DPCH. So in low chip rate TDD option, the PRACH is uplink synchronized with other uplink traffic, the burst type used on the PRACH is the same as for DPCH while in high chip rate TDD option the burst type of the PRACH is different from that of DPCH. The use of SF4 is necessary to support large RACH messages.

7.2.3.5 The synchronisation channel (SCH)

[Description:]

There are two dedicated physical synchronisation channels —DwPTS and UpPTS in each subframe of the low chip rate option as described in subclause 7.2.1 'Frame Structure' and 7.2.2.2 'Burst Types'.

[Rationale:]

The burst structures used for DwPTS and UpPTS are different from that used for other physical channels. The detailed description of the burst structure of DwPTS and UpPTS can be found in subclause 7.2.2.2 'Burst Types'.

As described in subclause 7.2.2.2 'Burst Types', there are no training sequences in DwPTS and UpPTS. The SYNC-DL code in DwPTS and the SYNC-UL code in UpPTS are not spread.

[Explanation difference:]

In low chip rate option, there are two dedicated Physical Synchronisation Channels, DwPTS for the down link synchronisation and UpPTS for the uplink synchronisation.

In high chip rate option, there is only one dedicated Physical Synchronisation Channel for down link synchronisation

7.2.3.6 Physical Uplink Shared Channel (PUSCH)

'Common with the high chip rate TDD mode'

7.2.3.7 Physical Downlink Shared Channel (PDSCH)

'Common with the high chip rate TDD mode'

7.2.3.8 The Page Indicator Channel (PICH)

[Description:]

The Page Indicator Channel (PICH) is a physical channel used, as in 3.84 MCPS TDD option, to carry the Page Indicators (PI).

The PICH can be transmitted time multiplexed with a P/S-CCPCH and it is with the same antenna pattern configuration as the P-CCPCH. The power offset of PICH compared to the P-CCPCH is broadcast on BCH.

The Paging Indicator Channel (PICH) is a physical channel used to carry the paging indicators.

7.2.3.8.1 Mapping of Paging Indicators to the PICH bits

Figure 7 depicts the structure of a PICH transmission and the numbering of the bits within the bursts. The burst type as described in [6.2.2 ‘Burst Format’] is used for the PICH. N_{PIB} bits are used to carry the paging indicators, where $N_{PIB}=352$.

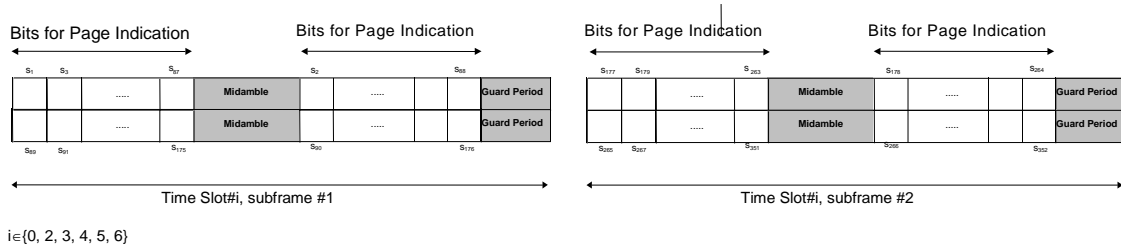

Figure 7: Transmission and numbering of paging indicator carrying bits in the PICH bursts

Each paging indicator P_q (where $P_q, q = 0, \dots, N_{PI}-1, P_q \in \{0, 1\}$) in one radio frame is mapped to the bits $\{s_{2L_{PI} \cdot q+1}, \dots, s_{2L_{PI} \cdot (q+1)}\}$ in subframe #1 or subframe #2. There are $N_{PIB} = 2 \cdot N_{PI} \cdot L_{PI}$ bits used for the paging indicator transmission in one radio frame. The mapping of the paging indicators to the bits $s_i, i = 1, \dots, N_{PIB}$ is shown in table 12.

Table 12: Mapping of the paging indicator

P_q	Bits $\{s_{2L_{PI} \cdot q+1}, s_{2L_{PI} \cdot q+2}, \dots, s_{2L_{PI} \cdot (q+1)}\}$	Meaning
0	$\{0, 0, \dots, 0\}$	There is no necessity to receive the PCH
1	$\{1, 1, \dots, 1\}$	There is the necessity to receive the PCH

The bits $s_k, k = 1, \dots, S$ are then transmitted over the air as shown in [7].

In each radio frame, N_{PI} paging indicators are transmitted, using $L_{PI}=2, L_{PI}=4$ or $L_{PI}=8$ symbols. In table 13 this number is shown for the different possibilities of paging indicator lengths.

Table 13: Number N_{PI} of paging indicators per radio frame for different paging indicator lengths L_{PI}

	$L_{PI}=2$	$L_{PI}=4$	$L_{PI}=8$
N_{PI} per radio frame	88	44	22

7.2.3.8.2 Structure of the PICH over multiple radio frames

The structure of the PICH over multiple radio frames is common with 3.84 Mcps TDD, cf. [5.3.7.2 Structure of the PICH over multiple radio frames]

[Rationale:]

PICH physical channel allows to improve the DRX mode at the UE, saving power consumption. The benefit of this channel have already been evaluated for the high chip rate TDD and FDD mode where it is now included; therefore it is recommended for its inclusion in the low chip rate TDD option as well.

[Differences:]

While no difference exists in principle between high chip rate TDD and low chip rate TDD PICH physical channel, there are differences in the burst structure coming from the different burst formats and the different number of supporting resource units in the respective TDD options.

7.2.4 Beacon function of physical channels

[Description:]

For the purpose of measurements, a beacon function shall be provided by physical channels at particular locations (time slot, code). Considering about the physical character requirement of the beacon function the P-CCPCH in low chip rate TDD satisfies this requirement.

[Rationale:]

For the purpose of measurements, a beacon function is provided by physical channels at particular locations..

7.2.4.1 Location of physical channels with beacon function

The beacon function shall be provided by the physical channels that are allocated to channelisation code $C_{Q=16}^{(k=1)}$ and $C_{Q=16}^{(k=2)}$ in Timeslot#0.

Note that by this definition the P-CCPCH always has beacon characteristics.

7.2.4.2 Physical characteristics of the beacon function

The physical channels providing the beacon function:

- are transmitted with reference power;
- are transmitted without beamforming

use midambles $m^{(1)}$ and $m^{(2)}$ exclusively in this time slot

[Explanation difference:]

The location of beacon channels is fixed in low chiprate TDD.

7.2.5 Midamble Allocation for Physical Channels

'Common with the high chip rate TDD mode'

7.3 Mapping of transport channels to physical channels

[Description:]

This clause describes the way in which transport channels are mapped onto physical resources.

[Rational:]

Table 14: Transport channel to physical channel mapping

Transport channels	Physical channels
DCH	Dedicated Physical Channel (DPCH)
BCH	Primary Common Control Physical Channels (P-CCPCH)
PCH	Secondary Common Control Physical Channels(S-CCPCH)
FACH	Secondary Common Control Physical Channels(S-CCPCH)
RACH	Physical Random Access Channel (PRACH)
USCH	Physical Uplink Shared Channel (PUSCH)
DSCH	Physical Downlink Shared Channel (PDSCH)
	Downlink Pilot Channel (DwPCH)
	Uplink Pilot Channel (UpPCH)
	PICH
	FPACH

[Explanation difference:]

The PCH and FACH can be mapped on the S-CCPCH in low chip rate TDD option and the BCH is mapped onto the P-CCPCH. The physical channels DwPCH and UpPCH are used for downlink and uplink pilots. The physical channel FPACH is used to answer the UE and to request an adjustment of the timing and synchronization shift of the UE. These three channels are used for synchronization operation. For a detailed description, see subclause 7.3.2 of 25.928.

7.3.1 Dedicated Transport Channels

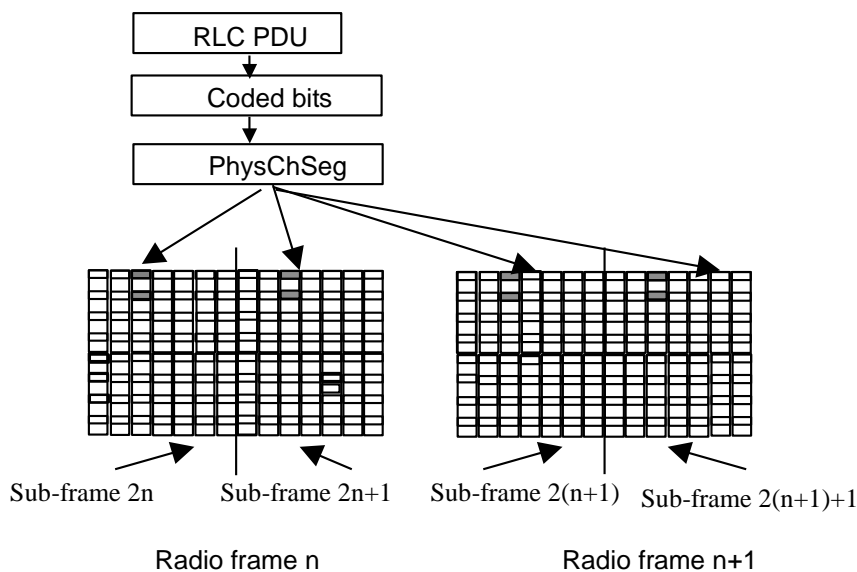

Figure 8: Mapping of PDU onto the physical bearer(TTI= 20ms)

[Description:]

The figure shows the mapping of PDU onto physical bearer.

[Explanation difference:]

The mapping of PDU into dedicated channel is different from that of high chip rate TDD option according to the different frame structure. See separate sections (clause 8.1.11) for further explanation of the segmentation into sub-frames.

7.3.2 Common Transport Channels

[Description:]

The following figure shows the mapping of BCH onto the P-CCPCHs :

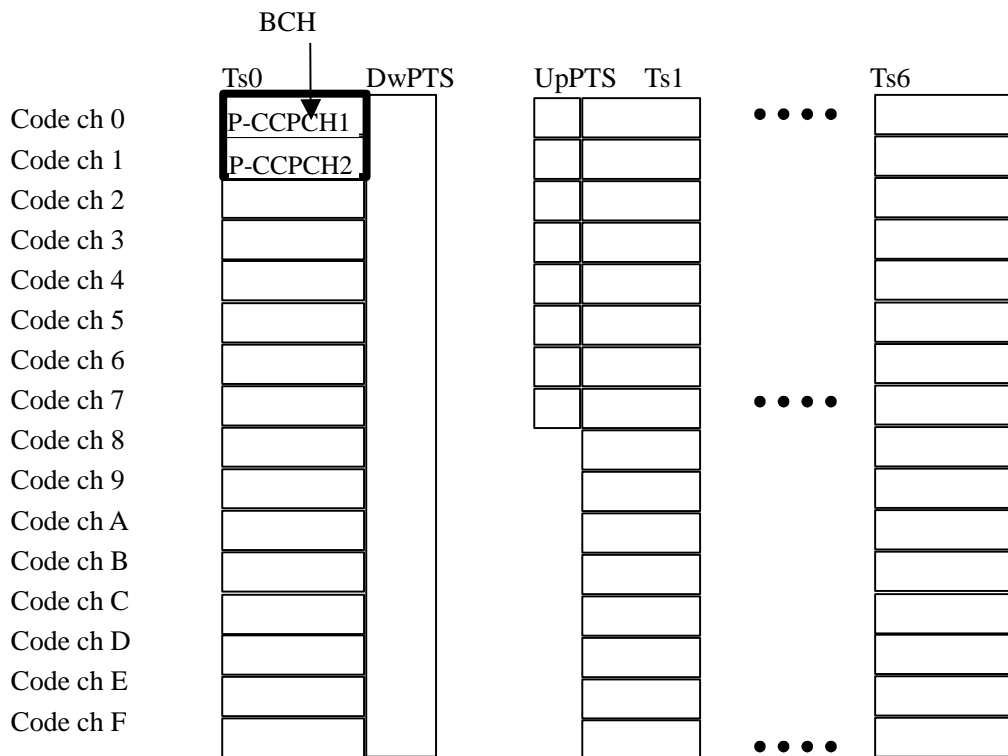

Figure 9: Transport channels mapping onto the physical channels

In low chip rate option, There are two P-CCPCH, P-CCPCH 1 and P-CCPCH 2 which are mapped onto channelisation codes $c_{Q=16}^{(k=1)}$ and $c_{Q=16}^{(k=2)}$ (spreading factor 16). A cell should always contain P-CCPCH 1 and P-CCPCH 2. The transport channels mapped onto the P-CCPCH shall effectively be mapped onto P-CCPCH 1 and P-CCPCH 2 using the multi-code function in the channel coding and multiplexing (See physical channel segmentation in 25.222). As far as the S-CCPCH is concerned, two cases can be considered. Either there are as well two S-CCPCH, S-CCPCH 1 and S-CCPCH 2 mapped onto two codes of spreading factor 16. The S-CCPCHs may be mapped on any DL time slot. (as show in the figure above). More details are giving as following:

The BCH is mapped on a pre-defined number of RUs/physical channels, so that the UE can unambiguously decode it. As it is for the TDD high chip rate option and for FDD mode, the low chip rate option as well foresees for one P-CCPCH only.

[Rational:]

7.3.2.1 The Broadcast Channel (BCH)

The BCH is always mapped on the P-CCPCH1+P-CCPCH2. Due to the adoption of smart antenna, in order to provide the coverage of the whole cell, the P-CCPCHs must have in general higher transmission power level with omnidirectional or sectorial pattern (without adaptive beamforming) compared with the other physical channels which can be adaptively beamformed. The UE can find the beginning of each block which is delivered on the P-CCPCHs; that is the beginning of the interleaving period, through the DwPTS sequence and its relative phase with respect to the P-CCPCHs midamble sequences. Each DwPTS can have 4 different phases with respect to the MA of the P-CCPCH and can be independently assigned by the Node B.

7.3.2.2 The Paging Channel (PCH)

The PCH is a special broadcast channel used to page UEs from RNC. The PCH is mapped onto a S-CCPCH.

7.3.2.2 The Forward Channel (FACH)

The FACH is mapped onto one or several S-CCPCHs. The location of the FACH is indicated on the BCH and both, capacity and location can be changed, if required. FACH may or may not be power controlled.

[Explanation difference:]

As In the high chip rate option, the BCH is always mapped onto P-CCPCH and the PCH/FACH onto the S-CCPCH. The P-CCPCH always contains only the BCH. The beginning of the TTI for the P-CCPCH can be derived from the modulation of the DwPCH.

7.3.2.3 The Random Access Channel (RACH)

[Description:]

The RACH has intraslot interleaving only and is mapped onto PRACH. More than one slot per frame may be administered for the PRACH. The location of slots allocated to PRACH is broadcast on the BCH. The uplink sync codes (SYNC-UL sequences) used by the UEs for UL synchronisation have a well known association with the P-RACHs, as broadcast by the BCH. On the P-RACH, both power control and uplink synchronisation control are used. The burst type used on the P-RACH is the same as that for a dedicated physical channel.

[Rationale:]

The RACH is mapped onto the P-RACH physical channel. The P-RACH can be configured by the network operator.

The P-RACHs can use spreading factor 16, 8 or 4. The spreading codes and time slots assigned to the P-RACHs are broadcast by the cell from the BCH. The capability of mapping RACH onto any UL time slot offers more flexibility to the system. The interference handling is then configurable. As the RACH is different from the other traffic it may be advantageous to distribute the RACH resources on several time slots.

The uplink sync codes (SYNC-UL sequences) used by the UEs for UL synchronisation have a well known association to the P-RACHs, as broadcast by the BCH.

On the P-RACH, both power control and uplink synchronisation control is used.

The burst type used on the P-RACH is the same as for a traffic channel.

[Explanation difference:]

In low chip rate TDD option the random access procedure has two-step approach. The PRACH uses the close loop power control algorithm which is similar with the traffic channel..

In high chip rate TDD option the PRACH uses open loop power control. The details of the employed open loop power control algorithm may be different from the corresponding algorithm on other channels.

In low chip rate TDD option the burst type used on the P-RACH is the same as for a traffic channel while in high chip rate TDD option the burst type of the PRACH is a little different from the traffic channel.

7.3.2.4 The Uplink Shared Channel (USCH)

'Common with the high chip rate TDD mode'

7.3.2.5 The Downlink Shared Channel (DSCH)

'Common with the high chip rate TDD mode'

8 Multiplexing and channel coding

8.1 Transport channel coding/multiplexing

8.1.1 Error detection

'Common with the high chip rate TDD mode'

8.1.2 Transport block concatenation and code block segmentation

'Common with the high chip rate TDD mode'

8.1.3 Channel coding

[Description:]

Usage of coding scheme and coding rate for the different types of TrCH is shown in table 15. In low chip rate TDD option, the coding scheme and coding rate of most type of TrCH are common with the high chip rate TDD.. Only BCH/PCH is a little different , it is mapped onto two code channels of the DL time slot. Rate 1/3 Convolutional coding is used for BCH and PCH.

[Rational:]

Usage of coding scheme and coding rate for the different types of TrCH is shown in table below. In low chip rate TDD option, BCH/PCH is mapped onto two physical channels of the DL time slot. If the usage of coding scheme and coding rate is 1/2 Convolutional coding, repeating as rate matching would be needed. So, it is used 1/3 Conv. coding as the coding scheme, this will lead to a better performance.

Table 15: Usage of channel coding scheme and coding rate

Type of TrCH	Coding scheme	Coding rate
BCH	Convolutional coding	1/3
PCH		1/3, 1/2
RACH		1/2
		1/3, 1/2
DCH, DSCH, FACH, USCH	Turbo coding	1/3
	No coding	

The coding scheme and coding rate of other TrCH are common with high chip rate TDD and the following subclauses can be mentioned as "common with high rate TDD":

8.1.3.1 Convolutional Coding

8.1.3.2 Turbo coding

8.1.3.2.1 Turbo coder

8.1.3.2.2 Trellis termination in turbo code

8.1.3.2.3 Turbo code internal interleaver

[Explanation difference:]

In high chip rate option, the coding scheme and coding rate of BCH/PCH is 1/2 Conv. coding. While in the low chip rate option, it is used 1/3 Conv. coding as the coding scheme and coding rate of BCH and PCH in low chip rate TDD option.

8.1.4 Radio frame size equalisation

'Common with the high chip rate TDD mode'

8.1.5 1st interleaving

'Common with the high chip rate TDD mode'

8.1.6 Radio frame segmentation

'Common with the high chip rate TDD mode'

8.1.7 Sub-frame segmentation

[Description:]

In the low chip rate option the radio frame which has a duration of 10 ms is subdivided into 2 subframes of 5ms each. The basic operated unit is a subframe. The bit streams in CCTrCH are mapped onto code channels of time slots in subframes. So, in low chip rate TDD option, it is needed to add the subframe segmentation unit between 2nd interleaving unit and physical channel mapping unit.

[Rational:]

In low chip rate option the radio frame which has a duration of 10 ms is subdivided into 2 subframes of 5ms each. The basic operated unit is a subframe. The bit streams in CCTrCH are mapped onto code channels of time slots in subframes. So, in low chip rate TDD option, it is needed to add subframe segmentation unit between 2nd interleaving unit and physical channel mapping unit. The operation of rate-matching guarantees that the bit streams is a even number and can be subdivided into 2 subframes. The transport channel multiplexing structure for uplink and downlink is shown in figure below.

The input bit sequence is denoted by $x_{i1}, x_{i2}, x_{i3}, \dots, x_{iX_i}$ where i is the TrCH number and X_i is the number bits. The two output bit sequences per radio frame are denoted by $y_{i,n_1}, y_{i,n_2}, y_{i,n_3}, \dots, y_{i,n_i}$ where n_i is the subframe number

in current radio frame and Y_i is the number of bits per radio frame for TrCH i . The output sequences are defined as follows:

$$y_{i,n_i k} = x_{i,((n_i-1)Y_i)+k}, n_i = 1 \text{ or } 2, k = 1 \dots Y_i$$

where

$Y_i = (X_i / 2)$ is the number of bits per subframe,

x_{ik} is the k^{th} bit of the input bit sequence and

$y_{i,n_i k}$ is the k^{th} bit of the output bit sequence corresponding to the n^{th} subframe

The input bit sequence to the radio frame segmentation is denoted by $v_{(t)1}, v_{(t)2}, \dots, v_{(t)U_i}$, $x_{ik} = v_{(t)k}$ and $X_i = U_i$.

The output bit sequence corresponding subframe n_i is denoted by $g_{p1}, g_{p2}, \dots, g_{pU_p}$, where p is the PhCH number and U_p is the number of bits in one subframe for the respective PhCH. Hence, $g_{pk} = y_{i,n_i k}$ and $U_p = Y_i$.

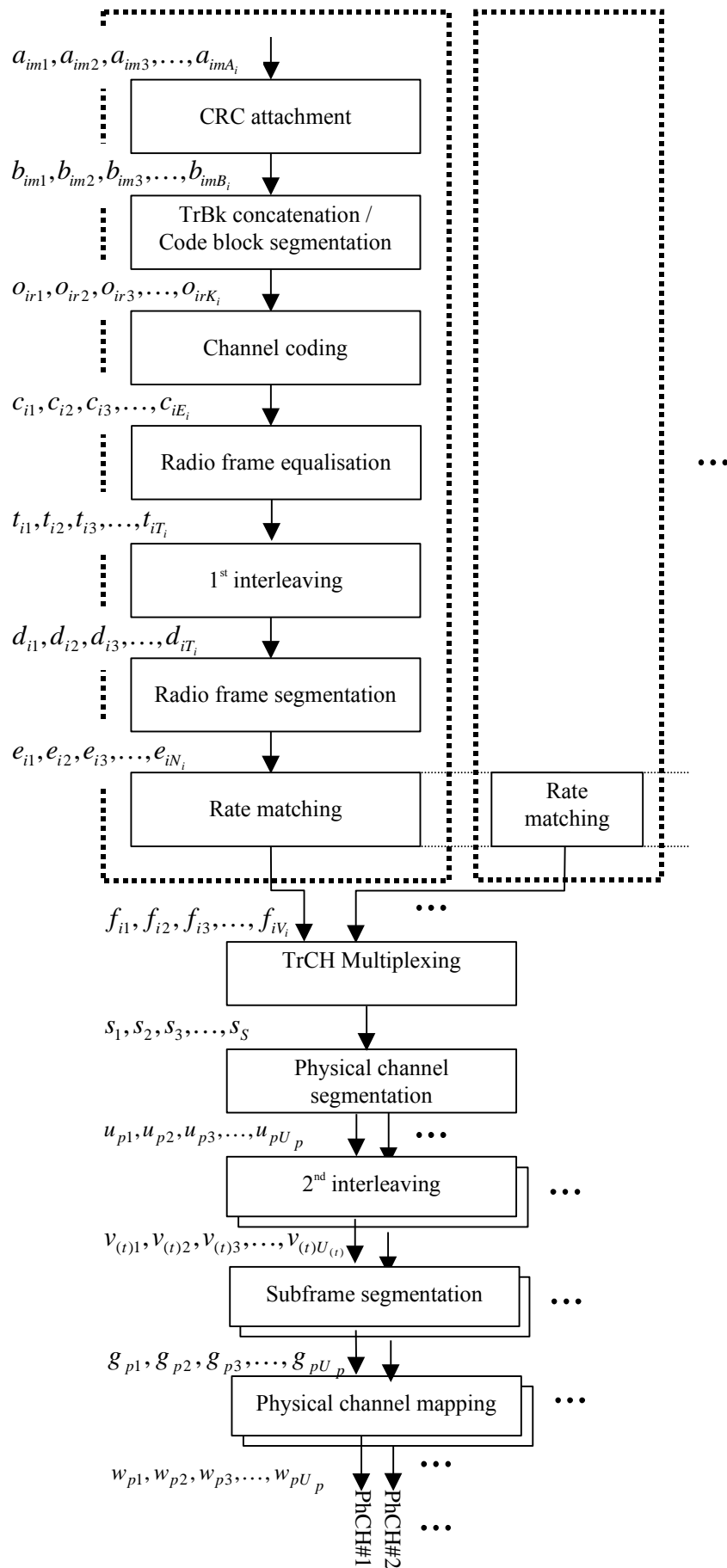

Figure 10: Transport channel multiplexing structure for uplink and downlink

[Explanation difference:]

In low chip rate option the radio frame which has a duration of 10 ms is subdivided into 2 subframes of 5ms each. The bit streams in CCTrCH are mapped onto code channels of time slots in subframes. So, in low chip rate TDD option, it is needed to add subframe segmentation unit between 2nd interleaving unit and physical channel mapping unit. While in high chip rate TDD option it is not included.

8.1.8 Rate matching

'Common with the high chip rate TDD mode'

8.1.9 TrCH multiplexing

'Common with the high chip rate TDD mode'

8.1.10 Physical channel segmentation

'Common with the high chip rate TDD mode'

8.1.11 2nd interleaving

'Common with the high chip rate TDD mode'

8.1.11.1 Frame related 2nd interleaving

8.1.11.2 Timeslot related 2nd interleaving

8.1.12 Physical channel mapping

[Description:]

In the low chip rate option the radio frame which has a duration of 10 ms is subdivided into 2 subframes of 5ms each. The basic operated unit is a subframe. So the bit streams from the subframe segmentation unit are mapped onto code channels of time slots in subframes in the low chip rate option.

[Rational:]

In the low chip rate option the radio frame which has a duration of 10 ms is subdivided into 2 subframes of 5ms each. The basic operated unit is a subframe. So the bit streams from the subframe segmentation unit are mapped onto code channels of time slots in subframes in the low chip rate option.

The PhCH for both uplink and downlink is defined in subclause 7.2. The bits after physical channel mapping are denoted by $w_{p1}, w_{p2}, \dots, w_{pU_p}$, where p is the PhCH number and U_p is the number of bits in one subframe for the respective PhCH. The bits w_{pk} are mapped to the PhCHs so that the bits for each PhCH are transmitted over the air in ascending order with respect to k .

The mapping of the bits $g_{p1}, g_{p2}, \dots, g_{pU_p}$ is performed like block interleaving, writing the bits into columns, but a PhCH with an odd number is filled in forward order, were as a PhCH with an even number is filled in reverse order.

The mapping scheme, as described in the following subclause, shall be applied individually for each timeslot t used in the current subframe. Therefore, the bits $g_{p1}, g_{p2}, \dots, g_{pU_p}$ are assigned to the bits of the physical channels

$w_{t1,1..U_{i1}}, w_{t2,1..U_{i2}}, \dots, w_{tP_i,1..U_{iP_i}}$ in each timeslot.

In uplink there are at most two codes allocated ($P \leq 2$). If there is only one code, the same mapping as for downlink is applied. Denote SF1 and SF2 the spreading factors used for code 1 and 2, respectively. For the number of consecutive bits to assign per code bs_k the following rule is applied:

if

SF1 >= SF2 then $bs_1 = 1$; $bs_2 = SF1/SF2$;

else

SF2 > SF1 then $bs_1 = SF2/SF1$; $bs_2 = 1$;

end if

In the downlink case bs_p is 1 for all physical channels.

8.1.12.1 Mapping scheme

Notation used in this subclause:

P_t : number of physical channels for timeslot t , $P_t = 1..2$ for uplink ; $P_t = 1..16$ for downlink

U_{tp} : capacity in bits for the physical channel p in timeslot t

U_t : total number of bits to be assigned for timeslot t

bs_p : number of consecutive bits to assign per code

for downlink all $bs_p = 1$

for uplink if SF1 >= SF2 then $bs_1 = 1$; $bs_2 = SF1/SF2$;

if SF2 > SF1 then $bs_1 = SF2/SF1$; $bs_2 = 1$;

fb_p : number of already written bits for each code

pos: intermediate calculation variable

for p=1 to P_t -- reset number of already written bits for every physical channel

$fb_p = 0$

end for

p = 1 -- start with PhCH #1

for k=1 to U_t ,

do while ($fb_p == U_{tp}$) -- physical channel filled up already ?

p = (p mod P_t)+1 ;

end do

if (p mod 2) == 0

pos = $U_{tp} - fb_p$ -- reverse order

else

pos = $fb_p + 1$ -- forward order

endif

$w_{tp\ pos} = g_{t,k}$ -- assignment

$fb_p = fb_p + 1$ -- Increment number of already written bits

if (fb_p mod bs_p) == 0 -- Conditional change to the next physical channel

p = (p mod P_t)+1;

end if

end for

[Explanation difference:]

In the high chip rate TDD option, the bit streams from the 2nd interleaving unit are mapped onto code channels of timeslots in radio frames. While in the low chip rate option the radio frame which has a duration of 10 ms is subdivided into 2 subframes of 5ms each. The basic operated unit is a subframe. So the bit streams from the subframe segmentation unit are mapped onto code channels of time slots in subframes in the low chip rate option.

8.1.13 Multiplexing of different transport channels onto one CCTrCH, and mapping of one CCTrCH onto physical channels

'Common with the high chip rate TDD mode'

8.1.13.1 Allowed CCTrCH combinations for one UE

8.1.13.1.1 Allowed CCTrCH combinations on the uplink

8.1.13.1.2 Allowed CCTrCH combinations on the downlink

8.1.14 Transport format detection

'Common with the high chip rate TDD mode'

8.2 Coding for layer 1 control

8.2.1 Coding of transport format combination indicator (TFCI)

[Description:]

Encoding of the TFCI bits depends on the number of them and the mode of modulation applied. When the modulation of QPSK is deployed, encoding of the TFCI bits is the same as it in the high chip rate option. When the modulation of 8PSK is applied, the encoding of the TFCI bits is a little different from it in high chip rate option.

[Rationale:]

Encoding of the TFCI bits depends on the number of them and the mode of modulation applied. When the modulation of QPSK is deployed, encoding of the TFCI bits is the same as it in the high chip rate option. That is to say, if there are 6-10 bits of TFCI, the TFCI bits are encoded using a (32, 10) sub-code of the second order Reed-Muller code. If the number of TFCI bits is in the range 3 to 5, the TFCI bits are encoded using a (16, 5) bi-orthogonal (or first order Reed-Muller) code. If the number of TFCI bits is 1 or 2, then repetition will be used for coding. In this case each bit is repeated to a total of 4 times giving 4-bit transmission ($N_{\text{TFCI}}=4$) for a single TFCI bit and 8-bit transmission ($N_{\text{TFCI}}=8$) for 2 TFCI bits. When 8PSK service is transmitted, the modulation of 8PSK is applied in low chip rate option. The amount of encoded bits of TFCI in this case will be 48, 24, 12, 6 respectively for the 6-10, 3-5, 2, 1 TFCI bits. The same TFCI lengths like in WB-TDD are supported (0, 4, 8, 16, 32).

8.2.1.1 Coding of transport format combination indicator (TFCI) for 8PSK

Encoding of TFCI bits depends on the number of them and the modulation in use. When 2 Mcps service is transmitted, 8PSK modulation is applied in 1.28 Mcps TDD option. The coding scheme for TFCI when the number of bits are 6 – 10, and less than 6 are described in section 4.4.2.1 and 4.4.2.2, respectively.

8.2.1.1.1 Coding of long TFCI lengths

When the number of TFCI bits are 6 – 10, the TFCI bits are encoded by using a (64,10) sub-code of the second order Reed-Muller code, then 16 bits out of 64 bits are punctured (Puncturing positions are 0, 4, 8, 13, 16, 20, 27, 31, 34, 38, 41, 44, 50, 54, 57, 61st bits). The coding procedure is shown in Figure 11.

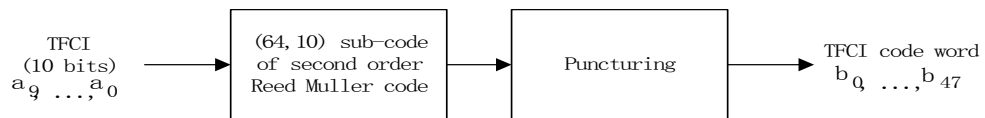

Figure 11: Channel coding of long TFCI bits for 8PSK

The code words of the punctured (48,10) sub-code of the second order Reed-Muller codes are linear combination of 10 basis sequences. The basis sequences are shown in Table 16.

Table 16: Basis sequences for (48,10) TFCI code

I	M _{i,0}	M _{i,1}	M _{i,2}	M _{i,3}	M _{i,4}	M _{i,5}	M _{i,6}	M _{i,7}	M _{i,8}	M _{i,9}
0	1	0	0	0	0	0	1	0	1	0
1	0	1	0	0	0	0	1	1	0	0
2	1	1	0	0	0	0	1	1	0	1
3	1	0	1	0	0	0	1	1	1	0
4	0	1	1	0	0	0	1	0	1	0
5	1	1	1	0	0	0	1	1	1	0
6	1	0	0	1	0	0	1	1	1	1
7	0	1	0	1	0	0	1	1	0	1
8	1	1	0	1	0	0	1	0	1	0
9	0	0	1	1	0	0	1	1	0	0
10	0	1	1	1	0	0	1	1	0	1
11	1	1	1	1	0	0	1	1	1	1
12	1	0	0	0	1	0	1	0	1	1
13	0	1	0	0	1	0	1	1	1	0
14	1	1	0	0	1	0	1	0	0	1
15	1	0	1	0	1	0	1	0	1	1
16	0	1	1	0	1	0	1	1	0	0
17	1	1	1	0	1	0	1	1	1	0
18	0	0	0	1	1	0	1	0	0	1
19	1	0	0	1	1	0	1	0	1	1
20	0	1	0	1	1	0	1	0	1	0
21	0	0	1	1	1	0	1	0	1	0
22	1	0	1	1	1	0	1	1	0	1
23	0	1	1	1	1	0	1	1	1	0
24	0	0	0	0	0	1	1	1	0	1
25	1	0	0	0	0	1	1	1	1	0
26	1	1	0	0	0	1	1	1	1	1
27	0	0	1	0	0	1	1	0	1	1
28	1	0	1	0	0	1	1	1	0	1
29	1	1	1	0	0	1	1	0	1	1
30	0	0	0	1	0	1	1	0	0	1
31	0	1	0	1	0	1	1	0	0	1
32	1	1	0	1	0	1	1	1	1	1
33	1	0	1	1	0	1	1	0	0	1
34	0	1	1	1	0	1	1	1	1	0
35	1	1	1	1	0	1	1	1	0	1
36	0	0	0	0	1	1	1	1	1	0
37	1	0	0	0	1	1	1	0	1	1
38	1	1	0	0	1	1	1	1	1	1
39	0	0	1	0	1	1	1	1	0	0
40	1	0	1	0	1	1	1	1	0	0
41	1	1	1	0	1	1	1	1	1	1
42	0	0	0	1	1	1	1	1	1	1
43	0	1	0	1	1	1	1	0	1	0
44	1	1	0	1	1	1	1	0	1	0
45	0	0	1	1	1	1	1	0	1	1
46	0	1	1	1	1	1	1	0	0	1
47	1	1	1	1	1	1	1	1	0	0

Let's define the TFCI bits as $a_0, a_1, a_2, a_3, a_4, a_5, a_6, a_7, a_8, a_9$, where a_0 is the LSB and a_9 is the MSB. The TFCI bits shall correspond to the TFC index (expressed in unsigned binary form) defined by the RRC layer to reference the TFC of the CCTrCH in the associated DPCH radio frame.

The output code word bits b_i are given by:

$$b_i = \sum_{n=0}^9 (a_n \times M_{i,n}) \bmod 2$$

where $i=0 \dots 47$. $N_{\text{TFCI}}=48$.

8.2.1.1.2 Coding of short TFCI lengths

8.2.1.1.2.1 Coding very short TFCIs by repetition

When the number of TFCI bits is 1 or 2, then repetition will be used for the coding. In this case, each bit is repeated to a total of 6 times giving 6-bit transmission ($N_{\text{TFCI}} = 6$) for a single TFCI bit and 12-bit transmission ($N_{\text{TFCI}} = 12$) for 2 TFCI bits. For a single TFCI bit b_0 , the TFCI code word shall be $\{b_0, b_0, b_0, b_0, b_0, b_0\}$. For TFCI bits b_0 and b_1 , the TFCI code word shall be $\{b_0, b_1, b_0, b_1, b_0, b_1, b_0, b_1, b_0, b_1, b_0, b_1\}$.

8.2.1.1.2.2 Coding short TFCIs using bi-orthogonal codes

If the number of TFCI bits is in the range of 3 to 5, the TFCI bits are encoded using a (32,5) first order Reed-Muller code, then 8 bits out of 32 bits are punctured (Puncturing positions are 0, 1, 2, 3, 4, 5, 6, 7th bits). The coding procedure is shown in Figure 12.

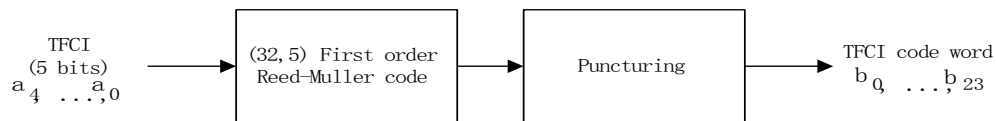

Figure 12: Channel coding of short TFCI bits for 8PSK

The code words of the punctured (32,5) first order Reed-Muller codes are linear combination of 5 basis sequences shown in Table 17.

Table 17: Basis sequences for (24,5) TFCI code

I	M _{i,0}	M _{i,1}	M _{i,2}	M _{i,3}	M _{i,4}
0	0	0	0	1	0
1	1	0	0	1	0
2	0	1	0	1	0
3	1	1	0	1	0
4	0	0	1	1	0
5	1	0	1	1	0
6	0	1	1	1	0
7	1	1	1	1	0
8	0	0	0	0	1
9	1	0	0	0	1
10	0	1	0	0	1
11	1	1	0	0	1
12	0	0	1	0	1
13	1	0	1	0	1
14	0	1	1	0	1
15	1	1	1	0	1
16	0	0	0	1	1
17	1	0	0	1	1
18	0	1	0	1	1
19	1	1	0	1	1
20	0	0	1	1	1
21	1	0	1	1	1
22	0	1	1	1	1
23	1	1	1	1	1

Let's define the TFCI bits as a_0, a_1, a_2, a_3, a_4 , where a_0 is the LSB and a_4 is the MSB. The TFCI bits shall correspond to the TFC index (expressed in unsigned binary form) defined by the RRC layer to reference the TFC of the CCTrCH in the associated DPCH radio frame.

The output code word bits b_i are given by:

$$b_i = \sum_{n=0}^4 (a_n \times M_{i,n}) \bmod 2$$

where $i=0 \dots 23$. $N_{\text{TFCI}}=24$.

8.2.1.1.3 Mapping of TFCI code word

Denote the number of bits in the TFCI code word by N_{TFCI} , and denote the TFCI code word bits by b_k , where $k = 0, \dots, N_{\text{TFCI}}-1$.

When the number of bits in the TFCI code word is 12, 24, or 48, the mapping of the TFCI code word to the TFCI bit positions in a time slot shall be as follows.

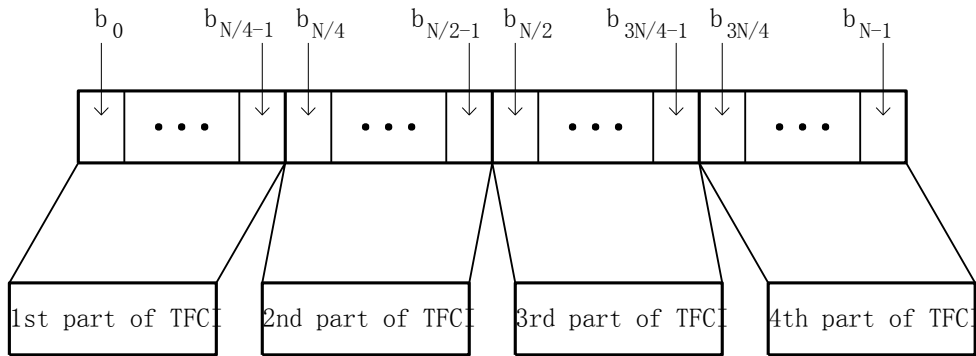

Figure 13: Mapping of TFCI code word bits to timeslot in 1.28 Mcps TDD option, where $N = N_{TFCI}$.

When the number of bits in the TFCI code word is 6, the TFCI code word is equally divided into two parts for the consecutive two sub-frames and mapped onto the first data field in each of the consecutive sub-frames. The mapping of the TFCI code word to the TFCI bit positions in a time slot shall be as shown in figure 14.

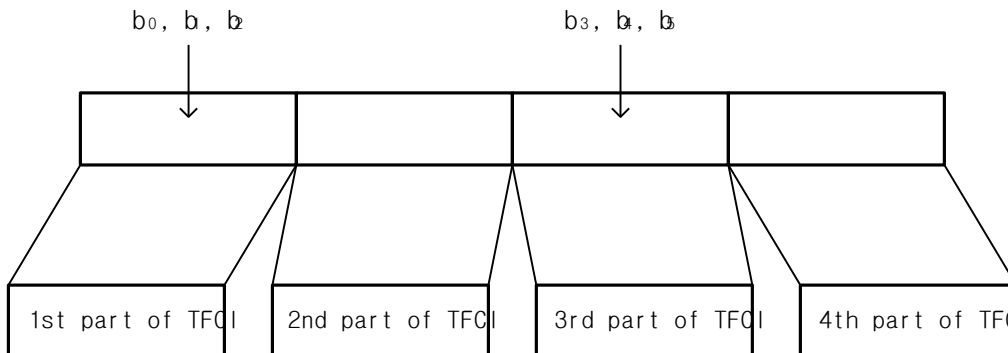

Figure 14: Mapping of TFCI code word bits to timeslot in 1.28 Mcps TDD option when $N_{TFCI} = 6$

The location of the 1st to 4th parts of TFCI in the timeslot is defined in [7].

[Explanation difference:]

In high chip rate option, encoding of the TFCI bits depends on the number of them. 1-10 bits of TFCI are supported. Thus, the amount of encoded bits of TFCI is 32, 16, 8, 4 respectively for the 6-10, 3-5, 2, 1 TFCI bits.

In the low chip rate option, encoding of the TFCI bits depends on the applied mode of modulation. QPSK is applied, encoding of the TFCI bits is the same as it in the high chip rate option.

8.2.2 Coding of Synchronisation Shift

[Description:]

The SS command, one kind of L1 control signals, is an identifier sent in downlink, to instruct a timing adjustment each M frames. The length of the SS command is 1 symbol.

[Rational:]

The SS command is sent in every sub-frame (in case allocated). The command may be updated only after every M sub-frames. 1. The coding of the SS command is shown in table below. M (1-8) and k (1-8) can be adjusted during call setup or readjusted during the call by higher layer.

Table 18: Coding of the SS

SS	SS Bits	Meaning
'Down'	00	Decrease synchronisation shift by $k/8 T_c$
'Up'	11	Increase synchronisation shift by $k/8 T_c$
'Do nothing'	01	No change

In case of 8PSK service, the numbers of the SS bits is 3. The specific coding of SS for the case of 8PSK is shown in table below.

Table 19: Coding of the SS (special for in case of 8PSK)

SS	SS Bits	Meaning
'Down'	000	Decrease synchronisation shift by $k/8 T_c$
'Up'	110	Increase synchronisation shift by $k/8 T_c$
'Do nothing'	011	No change

[Explanation difference:]

In high chip rate TDD option, SS information is not transmitted as L1 signal on each frame. Because of uplink synchronisation in the low chip rate TDD option, SS information is transmitted, as one of L1 signals, once per 5ms subframe.

The SS command is an identifier sent in downlink, to instruct a timing adjustment each M frames. The length of the SS command is 1 symbol. There are the three possibilities: "up", "down" or "do nothing".

8.2.3 Coding of Transmit Power Control (TPC) [Description:]

The TPC command, one kind of L1 control signals, is an identifier sent both in up- and downlink, to instruct a power level adjustment which is increase or decrease. The coding of the TPC command is shown.

[Rationale:]

The TPC command is an identifier sent both in up- and downlink, to instruct a power level adjustment which is increase or decrease. The length of the TPC command is one symbol. The coding of the TPC command is shown in table 20.

Table 20: Coding of the TPC

TPC	TPC Bits	Meaning
'Up'	11	Increase Tx Power
'Down'	00	Decrease Tx Power

When 8PSK modulation is applied, the length of the coded TPC command remains one symbol and therefore the number of TPC Bits is 3. The specific coding of TPC for the case of 8PSK is shown in table 21.

Table 21: Coding of the TPC (Special for 8PSK)

TPC	TPC Bits	Meaning
'Up'	110	Increase TX power
'Down'	000	Decrease TX power

Note : the TPC coding for 8PSK refer to 9.1.2

[Explanation difference:]

In high chip rate option, the TPC command is sent in uplink transmission only, to instruct the NodeB whether Tx power has to be increased or decreased. The length of the TPC command is one symbol.

In the low chip rate option, the TPC command is an identifier sent both in up- and downlink, to instruct a power level adjustment which is increase or decrease. When 8PSK modulation is applied the length of the coded TPC command remains one symbol and therefore the number of TPC Bits is 3. The specific coding of TPC for the case of 8PSK is shown in table above.

8.2.4 Coding of the Paging Indicator

Common with the high chip rate TDD option

9 Spreading and Modulation

9.1 Data modulation

[Description:]

This document is described the difference of modulation and spreading in low chip rate TDD. The main difference is the mapping of bits onto signal point constellation, synchronization codes and code Allocation.

[Rational:]

9.1.2 Mapping of bits onto signal point constellation

9.1.2.1 QPSK modulation

'Common with high chip rate TDD'

9.1.2.2 8PSK modulation

The data modulation is performed to the bits from the output of the physical channel mapping procedure for 8PSK service 3 consecutive binary bits to a complex valued data symbol. Each user burst has two data carrying parts, termed data blocks:

$$\underline{\mathbf{d}}^{(k,i)} = (\underline{d}_1^{(k,i)}, \underline{d}_2^{(k,i)}, \dots, \underline{d}_{N_k}^{(k,i)})^T \quad i = 1, 2; k = 1, \dots, K. \quad (1)$$

N_k is the number of symbols per data field for the user k . This number is linked to the spreading factor Q_k .

Data block $\underline{\mathbf{d}}^{(k,1)}$ is transmitted before the midamble and data block $\underline{\mathbf{d}}^{(k,2)}$ after the midamble. Each of the N_k data symbols $\underline{d}_n^{(k,i)}$; $i=1, 2$; $k=1, \dots, K$; $n=1, \dots, N_k$; of equation 1 has the symbol duration $T_s^{(k)} = Q_k T_c$ as already given.

The data modulation is 8PSK, thus the data symbols $\underline{d}_n^{(k,i)}$ are generated from 3 consecutive data bits from the output of the physical channel mapping procedure:

using the following mapping to complex symbols:

Table 22

Consecutive binary bit pattern	complex symbol
$b_{1n}^{(k,i)} b_{2n}^{(k,i)} b_{3n}^{(k,i)}$	$\underline{d}_n^{(k,i)}$
000	$\text{Cos}(11\pi/8) + \text{jsin}(11\pi/8)$
001	$\text{Cos}(9\pi/8) + \text{jsin}(9\pi/8)$
010	$\text{Cos}(5\pi/8) + \text{jsin}(5\pi/8)$
011	$\text{Cos}(7\pi/8) + \text{jsin}(7\pi/8)\text{j}$
100	$\text{Cos}(13\pi/8) + \text{jsin}(13\pi/8)$
101	$\text{Cos}(15\pi/8) + \text{jsin}(15\pi/8)$
110	$\text{Cos}(3\pi/8) + \text{jsin}(3\pi/8)$
111	$\text{Cos}(\pi/8) + \text{jsin}(\pi/8)$

The mapping corresponds to a 8PSK modulation of the interleaved and encoded data bits $b_{l,n}^{(k,i)}$ of the table above and $\underline{d}_n^{(k,i)}$ of equation 1.

9.1.3 Symbol rate

'Common with the high chip rate TDD mode'

9.2 Spreading modulation

9.2.1 Basic spreading parameters

'Common with the high chip rate TDD mode'

9.2.2 Spreading codes

'Common with the high chip rate TDD mode'

9.2.3 Scrambling codes

'Common with the high chip rate TDD mode'

9.2.4 Spread and scrambled signal of data symbols and data blocks

'Common with the high chip rate TDD mode'

9.3 Synchronisation codes

DwPTS code

The DwPTS is composed of 64 chips (4 symbols) of SYNC-DL and 32 chips (2 symbols) of guard period as shown in Figure below. SYNC-DL code is not scrambled. There should be 32 different basic SYNC-DL codes for the whole system.

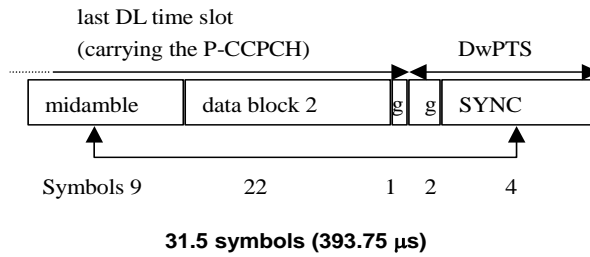

Figure 15: The frame structure around DwPTS

For the generation of the complex valued SYNC-DL codes of length 64, the basic binary SYNC-DL codes

$\mathbf{s} = (s_1, s_2, \dots, s_{64})$ of length 64 shown in Table A are used. The relation between the elements $\underline{\mathbf{s}}$ and \mathbf{s} is given by:

$$\underline{s}_i = (j)^i \cdot s_i \quad s_i \in \{1, -1\} \quad i=1, \dots, 64 \tag{1}$$

Hence, the elements $\underline{\mathbf{s}}_i$ of the complex SYNC-DL code $\underline{\mathbf{s}}$ are alternating real and imaginary.

The SYNC-DL is QPSK modulated and the phase of the SYNC-DL is used to signal the presence of the P-CCPCH in the multi-frame of the resource units of code $C_{Q=16}^{(k=1)}$ and $C_{Q=16}^{(k=2)}$ in time slot #0.

The SYNC-DL sequences are modulated with respect to the midamble ($m^{(1)}$) in time slot #0.

Four consecutive phases (phase quadruple) of the SYNC-DL are used to indicate the presence of the P-CCPCH in the following 4 sub-frames. In case the presence of a P-CCPCH is indicated, the next following sub-frame is the first sub-frame of the interleaving period. As QPSK is used for the modulation of the SYNC-DL, the phases 45, 135, 225, and 315° are used.

The total number of different phase quadruples is 2 (S1 and S2). A quadruple always starts with an even system frame number ((SFN mod 2) = 0). Table 23 is showing the quadruples and their meaning.

Table 23 Sequences for the phase modulation for the SYNC-DL

Name	Phase quadruple	Meaning
S1	135, 45, 225, 135	There is a P-CCPCH in the next 4 sub-frames
S2	315, 225, 315, 45	There is no P-CCPCH in the next 4 sub-frames

9.3.1 UpPTS code

Synchronisation sequences for the UpPTS (SYNC-UL)

SYNC-UL code is not scrambled.

The time slot is composed of 128chips of SYNC-UL and 32chips of GP as shown in Figure 16:16.

There should be 256 different SYNC-UL codes (see Table B) for the whole system.

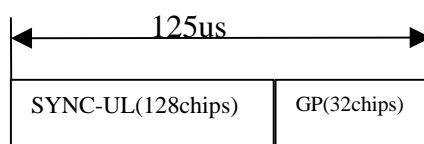

Figure 16: Burst structure of UpPTS

The possible restriction to the network planning from parameter grouping is to be verified.

9.3.2 Code Allocation

Relationship between the SYNC-DL and SYNC-UL sequences, the scrambling codes and the midamble codes

Table 24

Code Group	Associated Codes			
	SYNC-DL ID	SYNC-UL ID (coding criteria)	Scrambling Code ID (coding criteria)	Basic Midamble Code ID (coding criteria)
Group 1	0	0~7 (000~111)	0 (00)	0 (00)
			1 (01)	1 (01)
			2 (10)	2 (10)
			3 (11)	3 (11)
Group 2	1	8~15 (000~111)	4 (00)	4 (00)
			5 (01)	5 (01)
			6 (10)	6 (10)
			7 (11)	7 (11)
.
Group 32	31	248~255 (000~111)	124 (00)	124 (00)
			125 (01)	125 (01)
			126 (10)	126 (10)
			127 (11)	127 (11)

Table 25: Basic SYNC-DL Codes

Code ID	SYNC-DL Codes of length 64
0	B3A7CC05A98688E4
1	9D559BD290606791
2	2CE7BA12A017C3A2
3	34511D20672F4712
4	9A772841474603F2
5	9109B1A5CE01F228
6	8FD429B3594501C0
7	25251354AA3F8C19
8	C9A3B8E0C043EA56
9	BA04B888E5BC1802
10	A735354299370207
11	74C3C8DA4415AE51
12	F4FD0458A0124663
13	A011D4E16C3D6064
14	BDA0661B0CAA8C68
15	8E31123F28928698
16	F095C1632E2906AB
17	B60B4A8A664071CF
18	AA094DCCE91E041A
19	C0C31CDA8A256807
20	D516964FB18C1890
21	30DE01834F4AACCE
22	8F700323BA5CAD34
23	1B50F4DEE0C1380C
24	443382164F56F2D1
25	E1E4005D49B846B4
26	040A97165330BFAA
27	C48E26881693AD78
28	D4354B2FE02361CC
29	5383AB6C8A10CE84
30	D417A730F2F12244
31	ABF0A0D905A939C4

Table 26: BasicSYNC-UL Codes

Code ID	SYNC-UL Codes of length 128
0	C11C20F0D1807DB8859175B798EC094A
1	91278068081EC8E74543DBC1C9AD4235
2	38F5AEE2E513DB12A663BA04160103E5
3	7AA8A0A210F12A1E4332F2EDD33011FC
4	C180EA3B9BA1774EB9611BD249C4A508
5	B072A2C839489D496B98CE9D0132FBC9
6	B2723EAC6EB01667F2B33961C8074234
7	C4144AD060F0EC095E227B92CF7C8280
8	653036A10D3054146FCF815986C63A14
9	F899CA61435D64DC07FDF04C4A0C053A
10	B56F2D6893A8051407F4C341D88DC7DC
11	DC0BE838242142EDE6413A72C88D74AA
12	22A2FD86E4086C70A4860B13C76E579F
13	A3CBC21322C97D2A02728E7875F39588
14	D4EC4F694A082CB38E3B1558A0FCC89F
15	CC891141C4E216D235C15CF5D3F9B002
16	A1993114C50B77CB0C0725D1E22FD016
17	24F73A979DE52F82E8800CCB93842A59
18	8F878FA04659842E294D8DEAB20BA2FD
19	AC90B0442D70662B028CF76A6BECDF09
20	D94A284DF64D7B0102F0E084C29C88C8
21	8603200C7596F24E865FD3815693358D
22	B466B12CF433642BD8B08F1F452E0550
23	86A3A1772C1C99FCA7DBBA0C312E34A0
24	622A1889F72A9A2C042D46F08EFEE1AC
25	BF220A362BC0D3B0D7CE400954C6CFAE
26	D28D73C52E89CF57905C502244F63616
27	AD4E1C2103697D64D8B9D4C035D90548
28	8F081A9BA12B6C6BD024531AA984D21C
29	E4092429BE82988E1E3585BF6A6AE550
30	08BD36E0A9C061782CB38B35B335CA56
31	1CDFF3CC2685D1C44F4A1059AB03F40A
32	506ED4E88FB1CECE3243F2A27A0221A4
33	846CF58A7AB613C83A24130B5778C0E2
34	A2711A99E26A0C75AC026F4CFAECE893
35	D846EEEBA2432AC05A01043C62579DCF
36	6B16B4E851CAF2121FC4CF88820C89E7
37	AA4889A78207674A74E10C6F2BE11D48
38	8534CF8145BC991052814ED5C72709EE
39	01AEF15D2290A84A607425746D9963C7
40	999188F758245D5164FE16D852942C71
41	CF71C008599287E446E30745BD56E2D2

Code ID	SYNC-UL Codes of length 128
42	248414BA0DF8CDC4711FE7C8707ED0AD
43	EB2E263EC016191C81AB714BFE4D2B30
44	862082A7482FAC1C499793A0D8CED670
45	DE2C22B2783AB75A7342608DE413840A
46	E31AA60B727F2CA2A78DAAC10665011D
47	CEF6CD06509870AC9E0177ACD550921D
48	E52C84D499FFCDC287581691471540F2
49	B33BF6551A4322504BEE0930BCA1EC68
50	555BE6886D0FC43D72315E6C6D384148
51	8444F67451EE23CE1240C90F0B52A492
52	5C290D28E84060E69D09788A261B10FF
53	337E0C35E83CD38CC5D45804241F952
54	A7879F0D31A8982A01EE6AC4952984DC
55	A37F506508928C70A83D69A2373781B9
56	42F55208EE12909803A7CBEB19B5419E
57	57E5E268A328FCC9ED04B9E5420AC702
58	EB033AD1222F84D8642C4E3FAAD28206
59	98EE1415F026AC0E862C520451697DD0
60	6A0528AEA4B7CD6702660D81F8821E19
61	763D626A87C603BCB09E1A4C800A378F
62	EEA61897879289340C23F669D6A03762
63	A6571B3CC2D0E04F017ACC808B92DCE7
64	DDF88B52EA1831D293A803CF23C8C471
65	6CA4D333A2684140475DAB491F61C17A
66	A7D2AD23043989A13289F7C3E135580A
67	B1C752FA66B41C81904EDE27EA000E2E
68	8694BE3CC1CB36BE2A095F89CC619080
69	9C20334E1BBC596B25E151180BF99940
70	484256214F81070DD9C49A2B05A43DCE
71	401A20BCBE29B7438A7AEE44635A9E23
72	8858585C3239CBF628033FA0DF189378
73	EFA36404C1BA5118CC5F9052FD28D9C3
74	155609873D8A042D496E6477B747C4F8
75	8446077883A6D7D2549CC9742E3FD023
76	E630142B189AA209371A6F0FFDBC30A7
77	C46060535AC6DBB2095F1D7826D0CD5C
78	E00D19E48797148B28DEDA9D429362E2
79	645DE447E938485489416CAFCC1C571F
80	DA10AFBF2AE61C593A1D88584DE30598
81	BB248AEA5FD3FE210CD48FC401E1A686
82	A89F146BD9191F445301C081CB6F5625
83	15BBF04F247C59150208949EB6B9CC58
84	08F48BFA7804B5B2CC2E96510232E062

Code ID	SYNC-UL Codes of length 128
85	9AA2BE74005A3679C626B209580B8D03
86	9D40664A2C808F2F293E255398B37E6A
87	6869C98A8AAD81CAE41A23C83FF9EEA0
88	576E8948E61BD0927C4140C3C04C4CF3
89	0F942C67A1137B6EAA058C2A74872C73
90	9D058E27ED546C10632684BBC84E5BC1
91	79D4B840E20148B134F90B51164BCBD0
92	0E35E1D8D1214C05FAC790B69B239150
93	FFA1BB0232CD71480BE5CA1C2A269F89
94	B2956F5F4E270446F9211584792628DB
95	F56CCA23421C8EC8F8A41F7DA4A41EA2
96	0B5ECA04F1789A7148C80C39D57D05F6
97	A10B538E8A8CFC8F8925C485F2A88660
98	9925C2C715001D9FC78ACCC51DA1AF34
99	0DAC9CFDEA40429A8B12C7D320D60F70
100	377FC9A097017958440914E83118E39D
101	8421096FA8B47E4E943B6473671955CC
102	574086183477C4F68540CB7E858263B1
103	895B6A8980C6703C779F49F40C5CFC19
104	D0D253E157BC19262150CEA668679E71
105	B8889C60EBA812BD7F0B6498823296D2
106	A13FB9F3A08528E44B13C12CF0D461AA
107	8D4DCFB4E43D6E2024B1F8470224AA330
108	536D159E119E0893838657B12A074E64
109	DCFD49C504AD3A2F049A0CB70238EC8A
110	D363DB4C46C11757FA8FB18139789102
111	424A1E8A1D4DA256E4CA3BC8C2201BE3
112	417B619ED30FEB0A847CC3A191A20398
113	843FBBC95453C61786D1332612B45B4D
114	F26CACC0732CF8ED0C5BC1462B1620B4
115	88E0FE440C70E9249A92A7AF94638880
116	99A52B7D8C950308057E0661D7459960
117	A5C28218BF5D16E63E42698A0A6B0896
118	B2763BEEC784A12E8C50778536921806
119	987B2B6A3A77A059B30A082457AB84E0
120	820DB500F1B206358D7A7F210AB85AA8
121	97760A5CFC5E03EB439C914590045938
122	896A720E8857C8708A59F8C94DE0841E
123	2D101F0CF95263843412577340DEBB11
124	E8E5214B4DCF5D11A245B0149D49C87C
125	51224EAA10099ACDE384834A5ADF03D8
126	64E51253554A230C186FDE4E8781BC09
127	A499E391E69ED08890AC1A82A6115BEC

Code ID	SYNC-UL Codes of length 128
128	EE54C6E1834210D3EC1B07A456B92AA8
129	949DB5CA82420B54C1E0BCC111E704D9
130	9439EE9A9E4C447D1AA350926495047F
131	AD095CC0E7438AECE38D60980B3F2D00
132	83089C254C5EE9788072BC3D9282F798
133	A27DC1A457BC5A56563D8A9B11203615
134	713053A9C0B1B08B14705FF5A7244DB4
135	D36D4B9F4007354E0EC1B0CA8C8C7124
136	82E7C990612114F1CCE1BD9509FD4386
137	C8D83FF0B48B14830D2015D53F8C0672
138	08AF223C869A36B169148FDDABB7D120
139	B6C284C600AD0A99F86C449F8F4C53A6
140	DC741B320C07682AF92AC4DBDE0C28C2
141	89B8D84FA902265850C0FA6FF0EB2C4F
142	A69445B3A52201DB984BC03D1956D7F3
143	0FE0F7224B7AD72E4D4530D0223F590C
144	1B8C06F051434048EB925133AD3BD3F9
145	E133D4C3C942726A351300C37E55D0DF
146	9E09481D1881A66F562D8B453BC83AB2
147	2397B04B60A3C5700907BDBBA4E818C8
148	8F81F7A08CC6C8DA3D692AD34F50C012
149	9AB325352981BCCFA072F8FDE3009221
150	4FA88B7F1F8A620C31B0D486C52AC2F6
151	097AF0ADD16D7D39851049F0130EE444
152	A5027732DACFF11C388D5820A4A9BA49
153	1CD981EA2EDB46218A407C7E20D4BE84
154	D0FD94279FA67EC61A3904C0AD8ACA04
155	EA73A9415EC2004D49E9D0F645961C75
156	005AF0614A7552041194DEECBF8DD016
157	B514481533DA0A731705B93CF634E40D
158	983054521841A6E4FF34B2C07B5684FE
159	C46D927D0FD2B2F509550025677C6871
160	2AD85C08127487C87ECE014D65169102
161	0F617852FA3930AA7EE74B400B2CC831
162	AE9D395004C6E27540C378625D36E0D6
163	DC4FA55750F10B0636248F12C212FFE4
164	D3602B8D6CBF1809C88B827185631ECF
165	A94825850708E7723EA8F22C44BF78B2
166	A62D231C16AEFE0B0026B306662945A
167	9C7BE810A86465A50551F89125D93B12
168	9712D9338B9CC60485C10172F50F121F
169	A3902CE0E0B9912591FF28C695728257
170	4167057891AB29473A9E0F67F3658921

Code ID	SYNC-UL Codes of length 128
171	B3368B91EC12A284BC414C8F0D7F8D20
172	EE21888101ABF06C1175828CB58B598D
173	E43923A00ECC32CCC2D162A4A44BD7F4
174	CC9E30B8538AD51703EEB6F70801AB22
175	B908AD2F1501DA1C156811736CD798CD
176	2B46302ACCC2F808797FC648A614326D
177	8A54494F1BE27235B8764023AA0FBCFA
178	BC1041E6F636421E89277DC154439103
179	275B39A63029B974E3561AE0A8FC8032
180	9283F6FE819B80492A22B85CE5CE5DC4
181	4CCB52C0CE058A78022C22DF5788CBCC
182	B0DF9608DE549A6F6C581516919A81E6
183	2CA185163CC36060D1E85BB0A7FBB988
184	66101D2846155CAC986FC790D2124EFC
185	8016E3904644D2093579B83BD7AB5071
186	531CAB7085BEC14257439658023647CF
187	DF2910165AA5051E41F6EB198E4D491C
188	BA32052042B0FB2188DE7857DA1B6788
189	9E6D075AFF0EA4153615E140BF380666
190	9ACC5A037902534642A3BE391AA40F9B
191	4D741A3B4499843010D7E5FA8988DC80
192	FA1421C96EDC6092726154560B1C2FC8
193	882946076223CAE0B0BFE3EDA59826D5
194	CEBB288C28B7472A0D3917012276C034
195	BD35A6E00C9528DB38289CF823C34F30
196	E2C93618B6B2800D51171A5F85746A55
197	B43EF39A1A64F0E220AF740F9494291B
198	AC537817C2612744A58132A8AFBC44A3
199	98A321249A821DDBF81C38235A371A14
200	AE1D46069090D81BB6B08FED9E687285
201	7EAE2415DC2CD60AE083249A33B56E05
202	3D942AAA9BC9F27289421CE0B301FB98
203	1548BA6D08530727AC6D059C005C6C42
204	FF47C21142C65B502DA70647BAE831D1
205	C83AA7FEAC5E51A08091E10DB0C233D9
206	E86EDD2EC2DAA3104229EDC43471A16A
207	22FAFB9C184B78B56EE91B6602C03244
208	E45631DC509B1290C08D2C1A1F15DBFE
209	D203C51207092B56568FDAD9E2D44473
210	2AA87F31A7D1AB1C90024F936006C4A5
211	913136153593DEABC7305BF0C5A62180
212	D8DA5FE401F2758642A082C53A6A5CB8
213	23C2295213147F324DE8EC1C103BAE88

Code ID	SYNC-UL Codes of length 128
214	883AF097FCDE82B366A1844245E0D727
215	79E5E9F8C933159ACADC22A06F900A70
216	FE40502B44A9E44B2C336250D47538CC
217	670452E19172C843176F1278FE41D584
218	B7EAA436078E6886A3024F593AD57580
219	1044D4CDD7230E7B1953AD1232DF07E2
220	4D821ECAC3D845A2E1011695624576FF
221	96622ED2FBD44D1B859D70601999F438
222	CCC31C3D6D5B41B8D82FF4522A4C0146
223	4A84F7CD62E0C712980E6A0C89BF394F
224	10E56751F000927284DBE174E68ECC4C
225	A3DE70921356F026E084CFE302A210A9
226	B12DA0621B343A8C3FE941A32EA5D571
227	D653135DE825A74B743E275C19020C71
228	5CAD301BF846B2EE921D33A3D4BB1220
229	1292445ACBB548C668FC3853578474E6
230	B94B4B89C0654688C9E007D9061DF5FE
231	75A2C91E76061A8680884E8BFD14A64A
232	83726F3070B47ECE21504A5065D74A36
233	964A471444A270840919F7FE07382D14
234	A582701EBFCA899B8497088C3560F300
235	64FCB63E21CAC63002D1E09FD1543274
236	B1E1C83F689ADF422C865F98D288838A
237	A06A0D822165D3F3416B47419ECCB547
238	1D2068039A32B7EF728914ECE07CB416
239	64C0CF81F78E8823ECC8661A5295422A
240	902A7243F593F2180E5A306A8438E6A9
241	A4CCED356D56BF1B41C28E1504301FE8
242	82AE90E2F76B3055A2E3A966025CC01A
243	8B90D5A62364E18574145C5895CEFF60
244	43F7EA1AB0D19032551AD9DE21307353
245	DD5D8424AC60360B1C14E65815C9B15E
246	C632A67382ECB2681DFB8525140E2878
247	3A6ACF212B6F8B9C53FF224C2E00C16C
248	86A90C267B1171093F362FE5CB14E3A0
249	EA262EC36E6589C3BB005426AF2590F4
250	200F03126C5B0D7B901128E7757C5F70
251	68FC090C2221AA98BF0D24E85066EFC2
252	9E26CEC67832FC42A87E92FA1015212E
253	ACD889634F79506F2582EA03240F2A07
254	AA65407E1F4A33BF9A62860A3D6A4CC0
255	B1B950AC76A608AA32D04B03C7FF24D3

[Explanation difference:]

For low chip rate have different frame structure. It has the special time slot DwPTS and UpPTS to estimate the UL-synchronization and Cell search. So the SYNC-DL and SYNC-UL code is needed in low chip rate TDD.

10 Physical layer procedures

10.1 Transmitter Power Control

[Description:]

The basic purpose of power control is to limit the interference level within the system thus reducing the intercell interference level and to reduce the power consumption in the UE.

[Rationale:]

General Parameters

The main characteristics of power control are summarized in the following table.

Table 27: Transmit Power Control characteristics

	Uplink	Downlink
Power control rate	Variable Closed loop: 0-200 cycles/sec. Open loop: (about 200us – 3575us delay)	Variable closed loop: 0-200 cycles/sec.
Step size	1,2,3 dB (closed loop)	1,2,3 dB (closed loop)
Remarks	All figures are without processing and measurement times	within one timeslot the powers of all active codes may be balanced to within a range of [20] dB

Note: All codes within one timeslot allocated to the same CCTrCH use the same transmission power in case they have the same Spreading Factor. Gainfactors are applied to consider different spreading factors.

10.1.2 Uplink Control

Open loop power control for the UpPTS

The transmit power level by a UE on the UpPTS shall be calculated based on the following equation:

$$P_{UpPTS} = L_{P-CCPCH} + PRX_{UpPTS,des}$$

where,

P_{UpPTS} : transmit power level in dBm,

$L_{P-CCPCH}$: measured path loss in dB (P-CCPCH reference transmit power level is broadcast on BCH),

$PRX_{UpPTS,des}$: desired RX power level at cell's receiver in dBm, which is broadcast on BCH.

The interference power on the UpPTS (I_{UpPTS}) measured by the Node B is reported to the RNC on a regular basis to allow the RNC to make a decision for new control parameters.

The network signals (on BCH) a power increment that is applied only for the access procedure. At each new transmission of a SYNC-UL burst during the access procedure, the transmit power level can be increased by this power increment.

10.1.2.1 Common Physical Channel

In low chip rate TDD option system, the F-PACH brings the answer to the SYNC-UL burst of the UE. The answer, a one burst long message, shall bring besides the acknowledgment to the received SYNC-UL burst, the timing and power level indications to prepare the transmission of the RACH burst.

The transmit power level on the PRACH is calculated by the following equation:

$$P_{\text{PRACH}} = L_{\text{P-CCPCH}} + \text{PRX}_{\text{PRACH,des}}$$

Where, P_{PRACH} is the UE transmit power level on the PRACH;

$\text{PRX}_{\text{PRACH,des}}$ is the desired receive power level on the PRACH, as signalled by the network on the F-PACH

The network computes the $\text{PRX}_{\text{PRACH,des}}$ by measuring the interference on the PRACH timeslot which has to be averaged over an configurable (by O&M) number of frames (N).

10.1.2.2 Dedicated Physical Channel

The closed loop power control makes uses of layer 1 symbol in the DPCH. The power control step can take the values 1,2,3 dB within the overall dynamic range 80dB. The initial transmission power of the uplink Dedicated Physical Channel is signalled by the UTRAN.

Closed-loop TPC is based on SIR, and the TPC processing procedures are described in this section. During this power control process, the node B periodically makes a comparison between the received SIR measured value and the target SIR value. When the measured value is higher than the target SIR value, TPC command = 'down'. When this is lower than the target SIR value, TPC command = 'up'. At the UE, soft decision on the TPC bits is performed, and when it is judged as 'down', the mobile transmit power shall be reduced by one power control step, whereas if it is judged as 'up', the mobile transmit power shall be raised by one power control step. A higher layer outer loop adjusts the target SIR. This scheme allows quality based power control.

When the TPC bit cannot be received due to out-of-synchronisation, the transmission power value shall be kept at a constant value. When SIR measurement cannot be performed for being out-of-synchronisation, the TPC command shall always be set to = 'up' during the period of being out-of-synchronisation.

10.1.3 Downlink Control

10.1.3.1 Common Physical Channel

The power of the P-CCPCH

The primary CCPCH transmit power is set by high layer signalling and can be changed based on network determination. The reference power of P-CCPCH is signalled on the BCCH on a periodic basis.

The power value for the F-PACH is set by the network.

The relative transmit power of the S-CCPCH and PICH compared to the P-CCPCH transmit power is set by higher layers.

10.1.3.2 Dedicated Physical Channel

The initial transmission power of the downlink Dedicated Physical Channel is set by the network until the first UL DPCH arrives. After the initial transmission, the node B transits into SIR-based closed-loop TPC.

The measurement of received SIR shall be carried out periodically at the UE. When the measured value is higher than the target SIR value, TPC command = 'down'. When this is lower than the target SIR value, TPC command = 'up'. At the Node B, soft decision on the TPC bits is performed, and when it is judged as 'down', the transmission power shall be reduced by one power control step, whereas if judged as 'up', the transmission power shall be raised by one power control step.

When the TPC bit cannot be received due to out-of-synchronisation, the transmission power value shall be kept at a constant value.

When SIR measurement cannot be performed due to out-of-synchronisation, the TPC command shall always be = 'up' during the period of being out-of-synchronisation.

[Explanation difference:]

In low chip rate TDD option, for uplink, the power control update of PRACH can be calculated according to the received power of UpPTS. The power control of the DPCH is closed loop transmitter power control. Closed loop power control in uplink is used because of beamforming. Open loop power control is under consideration if there is no beamforming. For the downlink the transmit power control adjustment of the S-CCPCH (for FACH) can be calculated according to the transmit power level signaled in the RACH.

In high chip rate TDD option, for uplink, the power controls of the PRACH and DPCH are open loop transmitter power control. For downlink, the initial transmission power of DPCH is set by the network.

Operation of multiple CCH is under studying.

10.2 UL Synchronisation

[Description:]

This section describes the detail description on the UL synchronization including the establishment of UL synchronization and maintenance of the UL synchronization.

[Rationale:]

10.2.1 General Description

Support of UL synchronization is mandatory for the UE.

10.2.1.1 Preparation of uplink synchronization (downlink synchronization)

When a UE is powered on, it first needs to establish the downlink synchronization with the cell. Only after the UE has established the downlink synchronization, it shall start the uplink synchronization procedure.

10.2.1.2 Establishment of uplink synchronization

The establishment of uplink synchronization is done during the random access procedure and involves the UpPCH and the PRACH.

Although the UE can receive the downlink signal from the Node B, the distance to Node B is still uncertain. This would lead to unsynchronised uplink transmission. Therefore, the first transmission in the uplink direction is performed in a special time-slot UpPTS to reduce interference in the traffic time-slots.

The timing used for the UpPCH is set e.g. according to the received power level of DwPCH and/or P-CCPCH.

After the detection of the SYNC_UL sequence in the searching window, the Node B will evaluate the timing, and reply by sending the adjustment information to the UE to modify its timing for next transmission. This is done with the FPACH within the following 4 sub-frames. After sending the PRACH the uplink synchronization is established. The uplink synchronization procedure shall also be used for the re-establishment of the uplink synchronization when uplink is out of synchronization.

10.2.1.3 Maintenance of uplink synchronization

Uplink synchronization is maintained in 1.28Mcps TDD by sending the uplink advanced in time with respect to the timing of the received downlink.

For the maintenance of the uplink synchronization, the midamble field of each uplink burst can be used.

In each uplink time slot the midamble for each UE is different. The Node B may estimate the timing by evaluating the channel impulse response of each UE in the same time slot. Then, in the next available downlink time slot, the Node B will signal Synchronisation Shift (SS) commands to enable the UE to properly adjust its Tx timing.

10.2.2 UpPCH

Open loop uplink synchronisation control is used for UpPCH.

The UE may estimate the propagation delay Δt_p based upon the path loss using the received P-CCPCH and/or DwPCH power.

The UpPCH is sent to the Node B advanced in time according to the timing of the received DwPCH. The time of the beginning of the UpPCH $T_{TX-UPPCH}$ is given by:

$$T_{TX-UPPCH} = T_{RX-DWPCH} - 2\Delta t_p + 12 \cdot 16 T_C$$

in multiple of 1/8 chips, where

$T_{TX-UPPCH}$ is the beginning time of UpPCH transmission with the UE's timing,

$T_{RX-DWPCH}$ is the received beginning time of DwPCH with the UE's timing,

$2\Delta t_p$ is the timing advance of the UpPCH ($UpPCH_{ADV}$).

10.2.3 PRACH

The Node B shall measure the received SYNC_UL timing deviation $UpPCH_{POS}$. $UpPCH_{POS}$ is sent in the FPACH and is represented as an 11 bit number (0-2047) being the multiple of 1/8 chips which is nearest to received position of the UpPCH.

Time of the beginning of the PRACH $T_{TX-PRACH}$ is given by:

$$T_{TX-PRACH} = T_{RX-PRACH} - (UpPCH_{ADV} + UpPCH_{POS} - 8 \cdot 16 T_C)$$

in multiple of 1/8 chips, where

$T_{TX-PRACH}$ is the beginning time of PRACH transmission with the UE's timing,

$T_{RX-PRACH}$ is the beginning time of PRACH reception with the UE's timing if the PRACH was a DL channel.

10.2.4 DPCH and PUSCH

The closed loop uplink synchronisation control uses layer 1 symbols (SS commands) for DPCH and PUSCH. After establishment of the uplink synchronisation, NodeB and UE start to use the closed loop UL synchronisation control procedure. This procedure is continuous during connected mode.

The Node B will continuously measure the timing of the UE and send the necessary synchronisation shift commands in each sub-frame. On receipt of these synchronisation shift commands the UE shall adjust the timing of its transmissions accordingly, in steps of $\pm k/8$ chips or do nothing, each M sub-frames.

The default value of M (1-8) and k (1-8) is broadcast in the BCH. The value of M and k can also be adjusted during call setup or readjusted during the call.

During a 1.28 Mcps TDD to 1.28 Mcps TDD hand-over the UE shall transmit in the new cell with timing advance TA adjusted by the relative timing difference Δt between the new and the old cell:

$$TA_{new} = TA_{old} + 2\Delta t.$$

10.2.4.1 Out of synchronization handling

Same as that of 3.84 Mcps TDD, cf. [4.2.2.3.3 Out of synchronisation handling.]

10.3 Synchronisation and Cell Search Procedures

10.3.1 Cell Search

[Description:]

In this section, a 4-step cell search procedure for low chip rate TDD option is described which is a slightly different with the current 3 step cell search procedure for high chip rate TDD option.

[Rational:]

During the initial cell search, the UE searches for a cell. It then determines the DwPTS synchronization, scrambling and basic midamble code identification, control multi-frame synchronisation and then reads the contents in BCH. This initial cell search is carried out in 4 steps:

Step 1: Search for DwPTS

During the first step of the initial cell search procedure, the UE uses the SYNC-DL (in DwPTS) to acquire DwPTS synchronization to a cell. This is typically done with one or more matched filters (or any similar device) matched to the received SYNC-DL which is chosen from PN sequences set. A single or more matched filter (or any similar device) is used for this purpose. During this procedure, the UE needs to identify which of the 32 possible SYNC-DL sequences is used.

Step 2: Scrambling and basic midamble code identification

During the second step of the initial cell search procedure, the UE receives the midamble of the P-CCPCH. The P-CCPCH is followed by the DwPTS. In the current low chip rate TDD option each DwPTS code corresponds to a group of 4 different basic midamble code. Therefore there are total 128 midamble codes and these codes are not overlapping with each other. Basic midamble code number divided by 4 gives the SYNC-DL code number. Since the SYNC-DL and the group of basic midamble codes of the P-CCPCH are related one by one (that is, once the SYNC-DL is detected, the 4 midamble codes can be determined), the UE knows which 4 basic midamble codes is used. Then the UE can determine the used basic midamble code using a try and error technique. The same basic midamble code will be used throughout the frame. As each basic midamble code is associated with a scrambling code, the scrambling code is also known by that time. According to the result of the search for the right midamble code, UE may go to next step or go back to step 1.

Step 3: Control multi-frame synchronisation

During the third step of the initial cell search procedure, the UE searches for the head of multi-frame indicated by QPSK phase modulation of the DwPTS with respect to the P-CCPCH midamble. The control multi-frame is positioned by a sequence of QPSK symbols modulated on the DwPTS. [n]consecutive DwPTS are sufficient for detecting the current position in the control multi-frame. To ensure correct decisions, an additional bit coded together with a BCH block, allows the UE to know the BCH interleaving block in P-CCPCH. According to the result of the control multi-frame synchronisation for the right midamble code, UE may go to next step or go back to step 2.

Step 4: Read the BCH

The (complete) broadcast information of the found cell in one or several BCHs is read. According to the result the UE may move back to previous steps or the initial cell search is finished.

[Explanation difference:]

The initial cell search procedure is optimized considering the frame structure that is needed to enable UL synchronization and other specific features and properties for low chip rate option .

For high chip rate option, the three steps are : slot synchronisation, frame synchronisation and code-group identification, scrambling code identification.

For low chip rate option, the four steps are : search for DwPTS , scrambling and basic midamble code identification, control multi-frame synchronisation and the read of BCH information.

10.4 Discontinuous transmission (DTX) of Radio Frames

'Common with the high chip rate TDD mode'

[Description:]

The different downlink transmit diversity schemes for different channel has been considered in low chip rate TDD option.

[Rationale:]

10.5 Downlink Transmit Diversity

10.5.1 Transmit Diversity for DPCH

'Common with the high chip rate TDD'

Difference: Time Switched Transmit Diversity (TSTD) may also be employed as transmit diversity scheme for downlink DPCH.

10.5.1.1 TSTD for DPCH

TSTD can be employed as transmit diversity scheme for downlink DPCH. An example for the transmitter structure of the TSTD transmitter is shown in figure 17. Channel coding, rate matching, interleaving, bit-to-symbol mapping, spreading, and scrambling are performed as in the non-diversity mode. Then the data is time multiplexed with the midamble sequence. Then, after pulse shaping, modulation and amplification, DPCH is transmitted from antenna 1 and antenna 2 alternately every sub-frame. Not all DPCH in the sub-frame need to be transmitted on the same antenna and not all DPCH within a sub-frame have to use TSTD. Figure 18 shows an example for the antenna switching pattern for the transmission of DPCH for the case that all physical channels are transmitted with TSTD and are using the same antenna in the sub-frame.

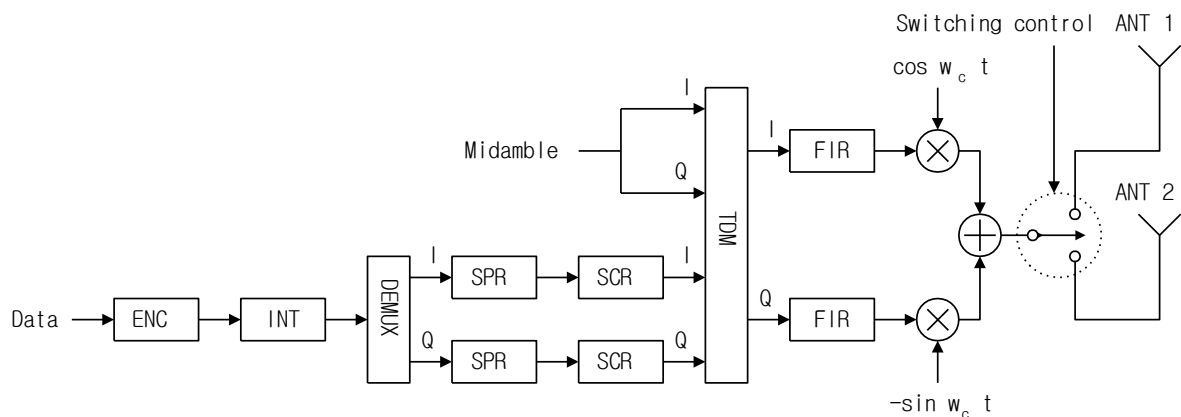

Figure 17: Example for TSTD Transmitter structure for DPCH and P-CCPCH

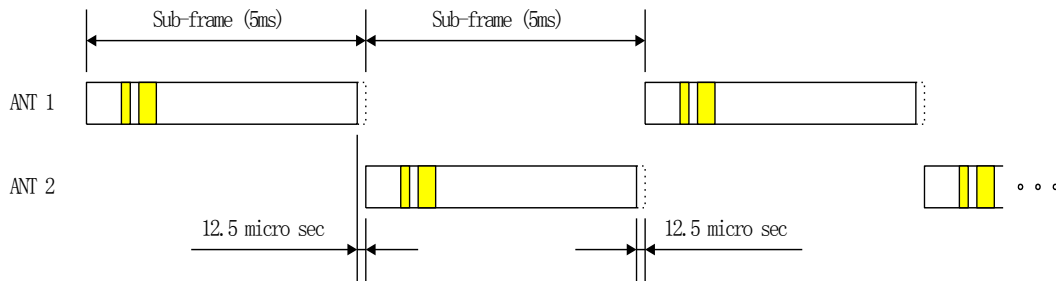

Figure 18: Example for the antenna switching pattern for TSTD transmission of DPCH and P-CCPCH: all physical channels are transmitted with TSTD and are using the same antenna in the sub-frame

10.5.1.2 Closed Loop Tx Diversity for DPCH

The transmitter structure to support transmit diversity for DPCH transmission is shown in figure 19. Channel coding, interleaving and spreading are done as in non-diversity mode. The spread complex valued signal is fed to both TX antenna branches, and weighted with antenna specific weight factors w_1 and w_2 . The weight factors are complex valued signals (i.e., $w_i = a_i + jb_i$), in general. These weight factors are calculated on a per slot and per user basis.

The weight factors are determined by the UTRAN.

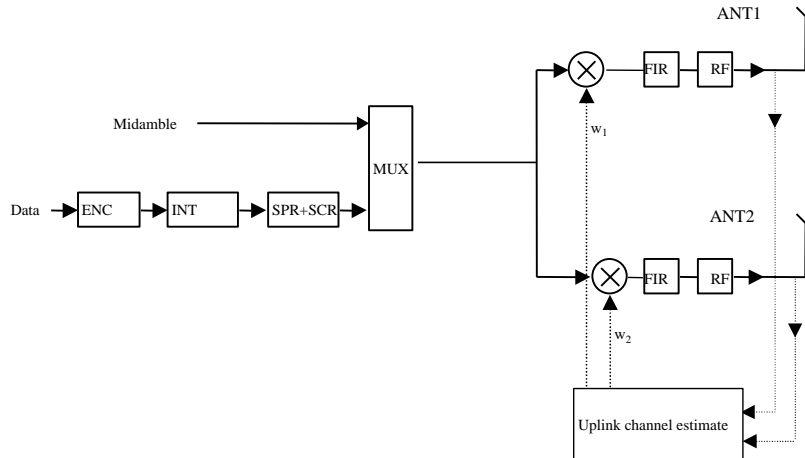

Figure 19: Downlink transmitter structure to support Transmit Diversity for DPCH transmission (UTRAN Access Point) in 1.28Mcps TDD

10.5.2 Transmit Diversity for DwPCH

The SCH function in high chip rate TDD has been achieved by DwPCH in low chip rate TDD and transmit diversity schemes for the DwPTS in low chip rate TDD is common with that for SCH in high chip rate TDD.

The transmitter structure to support transmit diversity for DwPCH transmission is shown in figure 20. DwPCH is transmitted from antenna 1 and antenna 2 alternatively.

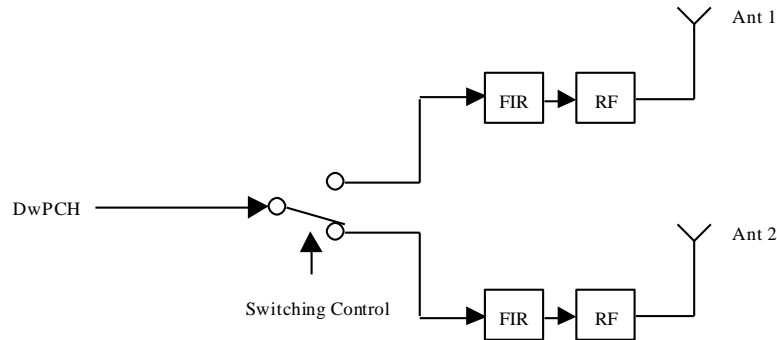

Figure 20: Downlink transmitter structure to support Transmit Diversity for DwPCH transmission (UTRAN Access Point) in 1.28Mcps TDD

10.5.3 Transmit Diversity for P-CCPCH

TSTD or Block Space Time Transmit Diversity (Block STTD) can be employed as transmit diversity scheme for the Primary Common Control Physical Channel (P-CCPCH)

10.5.3.1 TSTD Transmission Scheme for P-CCPCH

A block diagram of an example of a TSTD transmitter is shown in figure [6]. Channel coding, rate matching, interleaving, bit-to-symbol mapping, spreading, and scrambling are performed as in the non-diversity mode. Then the data is time multiplexed with the midamble sequence. Then, after pulse shaping and modulation and amplification, P-CCPCH is transmitted from antenna 1 and antenna 2 alternately every sub-frame. If there is a DPCH that uses TSTD, TSTD is also applied to P-CCPCH. An example of the antenna-switching pattern is shown in figure [7].

[Explanation difference:]

TSTD makes use of the subframe structure of 1.28Mcps TDD and is therefore also suited for 1.28Mcps TDD.

10.6 Random Access Procedure

[Description:]

The random access procedure and the collision problems for low chip rate option are described here. It include the preparation of random access, the random access procedure and the procedure for random access collision.

Note: In this paper, the FPACH is just a physical channel used to carry one burst message responding to SYNC-UL during random access procedure. There is no mapping relationship between FACH and FPACH. The FPACH here is a little like the AICH in FDD.

[Rationale:]

10.6.1 Preparation of random access

When the UE is in Idle mode, it will keep the downlink synchronisation and read the cell broadcast information. From the used DwPTS, the UE will get the code set of 8 SYNC-UL codes (signatures) assigned to UpPTS physical channel for random access. There are total 256 different SYNC-UL sequences. SYNC-UL sequences number divided by 8 gives the DwPTS sequences number. From the cell broadcast information, the UE will get to know the used SYNC-UL sequences within the code set to be used; the description (codes, spreading factor, midambles, time slots) of the P-RACH channels, the description (codes, spreading factor, midambles, time slots) of the FPACH channels, and other information (if needed) related to random access.

In the BCH it is described what SYNC-UL sequences are associated with what FPACH resources; what FPACHs are associated with what P-RACH resources and what P-RACH resources are associated with what S-CCPCH (carrying the FACH logical channel) resources.

Thus, when sending a SYNC-UL sequence, the UE knows which FPACH resources, P-RACH resources and CCPCH resources will be used for the access.

10.6.2 Random access procedure

The physical random access procedure described below is invoked whenever a higher layer requests transmission of a message on the RACH. The physical random access procedure is controlled by primitives from RRC and MAC.

10.6.2.1 Definitions

$FPACH_i$: FPACH number i

L_i : Length of RACH message associated to $FPACH_i$ in sub-frames

N_{RACH_i} : The number of PRACHs associated to the i^{th} FPACH

n_{RACH_i} : The number of a PRACH associated to the i^{th} FPACH ranging from 0 to $N_{RACH_i}-1$

M : Maximum number transmissions in the UpPCH

WT : Maximum number of sub-frames to wait for the network acknowledgement to a sent signature

SFN' : The sub-frame number counting the sub-frames. At the beginning of the frame with the system frame number $SFN=0$ the sub-frame number is set to zero.

10.6.2.2 Preparation of random access

When the UE is in Idle mode, it will keep the downlink synchronisation and read the cell broadcast information. From the used SYNC-DL code in DwPCH, the UE will get the code set of 8 SYNC-UL codes (signatures) assigned to UpPCH for random access.

The description (codes, spreading factor, midambles, time slots) of the P-RACH, FPACH, and S-CCPCH (carrying the FACH logical channel) channel is broadcast on the BCH.

Thus, when sending a SYNC-UL sequence, the UE knows which FPACH resources, P-RACH resources and CCPCH resources will be used for the access.

The UE needs to decode the BCH information regarding the random access prior to transmission on the UpPCH.

The physical random access procedure described in this sub-clause is initiated upon request of a PHY-Data-REQ primitive from the MAC sub-layer (see [18] and [19]).

Before the physical random-access procedure can be initiated, Layer 1 shall receive the following information by a CPHY-TrCH-Config-REQ from the RRC layer:

- The association between which signatures and which FPACHs; which FPACHs and which PRACHs; which PRACHs and which CCPCHs; including the parameter values for each listed physical channel.
- The length L_i of a RACH message associated to $FPACH_i$ can be configured to be either 1 or 2 or 4 sub-frames corresponding to a length in time of either 5 ms or 10 ms or 20 ms.

NOTE 1: N_{RACH_i} PRACHs can be associated with to $FPACH_i$. The maximum allowed

N_{RACH_i} is L_i .

- The available UpPCH sub-channels for each Access Service Class (ASC);

NOTE 2: An UpPCH sub-channel is defined by a (sub-set of) signature(s) and sub-frame numbers.

- The set of Transport Format parameters for the PRACH message;

- The "M" maximum number transmissions in the UpPCH;
- The "WT" maximum number of sub-frames to wait for the network acknowledgement to a sent signature; (1..4) the maximum value supported by Layer 1 is 4 sub-frames.
- The initial signature power "Signature_Initial_Power";

NOTE 3: The above parameters may be updated from higher layers before each physical random access procedure is initiated.

At each initiation of the physical random access procedure, Layer 1 shall receive the following information from the higher layers (MAC):

- The Transport Format to be used for the specific PRA CH message;
- The ASC for the specific Random Access procedure with the timing and power level indication;
- The data to be transmitted (Transport Block Set).

10.6.2.3 Random access procedure

The physical random-access procedure shall be performed as follows:

UE side:

- 1 Set the Signature Re-Transmission Counter to M.
- 2 Set the Signature transmission power to Signature_Initial_Power.
- 3 Randomly select the UpPCH sub-channel from the available ones for the given ASC. The random function shall be such that each of the allowed selections is chosen with equal probability.
- 4 Transmit a signature using the selected UpPCH sub-channel at the signature transmission power.
- 5 After sending a signature, listen to the relevant FPACH for the next WT sub-frames to get the network acknowledgement. The UE will read the FPACH_i associated to the transmitted UpPCH only in the sub-frames fulfilling the following relation:

$$(\text{SFN}' \bmod L_i) = n_{\text{RACH}_i}; n_{\text{RACH}_i} = 0, \dots, N_{\text{RACH}_i} - 1,$$

- 6 In case no valid answer is detected in the due time: decrease the Signature Re-transmission counter by one and if it is still greater than 0, then repeat from step 3; else report a random access failure to the MAC sub-layer.
- 7 In case a valid answer is detected in the due time
 - a) set the timing and power level values according to the indication received by the network in the FPACH_i
 - b) send at the sub-frame coming 2 sub-frames after the one carrying the signature acknowledgement, the RACH message on the relevant PRA CH. In case L_i is bigger than one and the sub-frame number of the acknowledgement is odd the UE will wait one more sub-frame. The relevant PRA CH is the n_{RACH_i}th PRA CH associated to the FPACH_i if the following equation is fulfilled:

$$(\text{SFN}' \bmod L) = n_{\text{RACH}_i};$$

Here SFN' is the sub-frame number of the arrival of the acknowledgement.

Both on the UpPCH and on the PRA CH, the transmit power level shall never exceed the indicated value signalled by the network.

Network side:

- The node B will transmit the FPA CH_i associated the transmitted UpPCH only in the sub-frames fulfilling the following relation:

$$(\text{SFN}' \bmod L) = n_{\text{RACH}_i}; n_{\text{RACH}_i} = 0, \dots, N_{\text{RACH}_i} - 1,$$

- The Node B will not acknowledge UpPCHs transmitted more than WT sub-frames ago

At the reception of a valid signature:

- Measure the timing deviation with respect to the reference time T_{ref} of the received first path in time from the UpPCH and acknowledge the detected signature sending the FPACH burst on the relevant FPACH.

For examples on the random access procedure refer to Annex E.

10.6.2.3.1 The use and generation of the information fields transmitted in the FPACH

The Fast Physical Access CHannel (FPACH) is used by the Node B to carry, in a single burst, the acknowledgement of a detected signature with timing and power level adjustment indication to a user equipment.

The length and coding of the information fields is explained in TS25.221 sub-clause 6.3.3.1.

10.6.2.3.1.1 Signature Reference Number

The Signature Reference Number field contains the number of the acknowledged signature. The user equipment shall use this information to verify whether it is the recipient of the FPACH message.

10.6.2.3.1.2 Relative Sub-Frame Number

The Relative Sub-Frame Number field indicates the current sub-frame number with respect to the sub-frame at which the acknowledged signature has been detected.

The user equipment shall use this information to verify whether it is the recipient of the FPACH message.

10.6.2.3.1.3 Received starting position of the UpPCH ($UpPCH_{POS}$)

The *received starting position of the UpPCH ($UpPCH_{POS}$)* field indirectly indicates to the user equipment the timing adjustment it has to implement for the following transmission to the network. The node B computes the proper value for this parameter according to the following rules: $UpPCH_{POS} = UpPTS_{R_{path}} - UpPTS_{TS}$

where

$UpPTS_{R_{path}}$: time of the reception in the Node B of the SYNC-UL to be used in the uplink synchronization process

$UpPTS_{TS}$: time instance two symbols prior to the end of the DwPCH according to the Node B internal timing

This information shall be used by the UE to adjust its timing when accessing the network as described in section 10.2. 'Uplink Synchronisation'

10.6.2.3.1.4 Transmit Power Level Command for the RACH message

This field indicates to the user equipment the power level to use for the RACH message transmission on the FPACH associated P-RACH.

The network may set this value based on the measured interference level (I) (in dBm) on the specific PRACH and on the desired signal to interference ratio (SIR) (in dB) on this channel as follows:

$$\text{Transmit Power Level Command for the PRACH} (PRX_{PRACH_{des}})$$

$PRX_{PRACH_{des}}$ is the desired receive power level on the PRACH.

The UE shall add to this value the estimated path-loss to compute the power level to transmit for the PRACH.

10.6.2.4 Random access collision

When a collision is very likely or in bad propagation environment, the Node B does not transmit the FPACH or cannot receive the SYNC-UL. In this case, the UE will not get any response from the Node B. Thus the UE will have to adjust its Tx time and Tx power level based on a new measurement and send a SYNC-UL again after a random delay.

Note that at each (re-)transmission, the SYNC-UL sequence will be randomly selected again by the UE.

Note : Due to the two-step approach a collision most likely happens on the UpPCH. The RACH RUs are virtually collision free. This two-step approach will guarantee that the RACH RUs can be handled with conventional traffic on the same UL time slots.

10.6.3 Random access collision

When a collision is very likely or in bad propagation environment, the Node B does not transmit the FPA CH or cannot receive the SYNC-UL. In this case, the UE will not get any response from the Node B. Thus the UE will have to adjust its Tx time and Tx power level based on a new measurement and send a SYNC-UL again after a random delay.

Note that at each (re-)transmission, the SYNC-UL burst will be randomly selected again by the UE.

Due to the two-step approach a collision most likely happens on the UpPTS. The RACH RUs are virtually collision free. This two-step approach will guarantee that the RACH RUs can be handled with conventional traffic on the same UL time slots.

[Explanation difference:]

Different from the high chip rate option , the random access procedure of low chip rate option has two-step approach. The SYNC-UL word is used to carry out uplink synchronisation and to resolve the access collision. This two-step procedure enables the RACH RUs to be handled with conventional traffic on the same UL time slots.

11 Physical layer measurements

All the sections of this chapter are marked as: 'Common with the high chip rate TDD mode'. The range/mapping values should be discussed in WG2/WG4.

11.1 Control of UE/UTRAN measurements

11.1.1 General measurement concept

'Common with the high chip rate TDD mode'

11.1.2 Measurements for cell selection/reselection

'Common with the high chip rate TDD mode'

11.1.3 Measurements for Handover

11.1.4 Measurements for DCA

'Common with the high chip rate TDD mode'

11.1.5 Measurements for timing advance

11.2 Measurement abilities for UTRA TDD

11.2.1 UE measurement abilities

11.2.1.1 PCCPCH RSCP

- 11.2.1.2 CPICH RSCP
- 11.2.1.3 RSCP
- 11.2.1.4 Timeslot ISCP
'Common with the high chip rate TDD mode'
- 11.2.1.5 UTRA carrier RSSI
- 11.2.1.6 GSM carrier RSSI
- 11.2.1.7 SIR
'Common with the high chip rate TDD mode'
- 11.2.1.8 CPICH E_c/N_0
- 11.2.1.9 Physical channel BER
- 11.2.1.10 Transport channel BLER
'Common with the high chip rate TDD mode'
- 11.2.1.11 UE transmitted power
'Common with the high chip rate TDD mode'
- 11.2.1.12 SFN-SFN observed time difference
- 11.2.1.13 Observed time difference to GSM cell

11.2.1.14 Timing Advance (T_{ADV}) for 1.28 Mcps TDD

Definition	The 'timing advance (T_{ADV})' is the time difference $T_{ADV} = T_{RX} - T_{TX}$ where T_{RX} : calculated beginning time of a certain uplink time slot with the UE timing according to the reception of a certain downlink time slot (for the timing it is assumed that the time slots within a sub-frame are scheduled like given in the frame structure described in 25.221 chapter 6.1) T_{TX} : time of the beginning of the same uplink time slot by the UE (for the timing it is assumed that the time slots within a sub-frame are scheduled like given in the frame structure described in 25.221 chapter 6.1)
-------------------	--

Annex A (Normative): Basic Midamble Codes

A.1 Basic Midamble Codes for Burst Type 1 and PRACH Burst Type

Table A.1: Basic Midamble Codes

Code ID	Basic Midamble Codes of length 128
0	B2AC420F7C8DEBFA69505981BCD028C3
1	0C2E988E0DBA046643F57B0EA6A435E2
2	D5CEC680C36A4454135F86DD37043962
3	E150D08CAC2A00FF9B32592A631CF85B
4	E0A9C3A8F6E40329B2F2943246003D44
5	FE22658100A3A683EA759018739BD690
6	B46062F89BB2A1139D76A1EF32450DA0
7	EE63D75CC099092579400D956A90C3E0
8	D9C0E040756D427A2611DAA35E6CD614
9	EB56D03A498EC4FEC98AE220BC390450
10	F598703DB0838112ED0BABB98642B665
11	A0BC26A992D4558B9918986C14861EFF
12	541350D109F1DD68099796637B824F88
13	892D344A962314662F01F9455F7BC302
14	49F270E29CCD742A40480DD4215E1632
15	6A5C0410C6C39AA04E77423C355926DE
16	7976615538203103D4DBCC219B16A9E1
17	A6C3C3175845400BD2B738C43EE2645F
18	A0FD56258D228642C6F641851C3751ED
19	EFA48C3FC84AC625783C6C9510A2269A
20	62A8EB1A420334B23396E8D76BC19740
21	9E96235699D5D41C9816C921023BC741
22	4362AE4CAE0DCC32D60A3FED1341A848
23	454C068E6C4F190942E0904B95D61DFB
24	607FEEA6E2E99206718A49C0D6A25034
25	E1D1BCDA39A09095B5C81645103A077C
26	994B445E558344DE211C8286DDD3D1A3
27	C15233273581417638906ADB61FDCA3C
28	8B79A274D542F096FB1388098230F8A1
29	DF58AC1C5F44B2A40266385CE1DA5640
30	B5949A1CC69962C464401D05FF5C1A7A
31	85AC489841ED3EAA2D83BBB0039CC707
32	AE371CC144BC95923CA8108D8B49FE82
33	7F188484A649D1C22BDA1F09D49B5117

Code ID	Basic Midamble Codes of length 128
34	ADAA3C657089DEF7C0284903A491C9B0
35	C3F96893C7504DC3B51488604AF64F4C
36	B4002F5AE0CE8623AC979D368E9148C1
37	0EEBCC0C795C02A106C24ABB36D08C6E
38	4B0F537E384A893F58971580D9894433
39	08E0035AB29B7ECC53C15DAA0687CC8F
40	8611ACBC4C82781D77654EE862506D60
41	63315261A8F1CB02549802DBFD197C07
42	9A2609A434F43E7DCADC0E22B2EF4012
43	F4C9F0A127A88461209ABF8C69CE4D00
44	C79124EE3FFC28C5C4524D2B01670D42
45	C91985C4FED53D09361914354BA80E79
46	82AA517260779ECFF26212C1A10BDC29
47	561DE2040ACB458E0DBD354E43E111D9
48	2E58C7202D17392BC1235782CEFABB09
49	C4FAA121C698047650F6503126A577C1
50	E7B75206A9B410E44346E0DAE842A23C
51	3F8B1C32682B28D098D3805ED130EA7F
52	8D5FC2C1C6715F824B401434C8D4BB82
53	0B2A43453ACC028FE6EB6E1CB0740B59
54	BC56948FC700BA4883262EE73E12D82A
55	558D136710272912FA4F183D1189A7FD
56	5709E7F82DC6500B7B12A3072D182645
57	86D4F161C844AE5E20EE39FD5493B044
58	8729B6EDC382B152185885F013DAE222
59	154C45B50720F4C362C14C77FE8335A1
60	C6A0962890351F4EB802DE43A7662C9E
61	D19D69D6B380B4B22457CB80033519F0
62	C7D89509FB0DAE9255998E0A00C2B262
63	DFD481C652C0C905D61D66F1732C4AA2
64	06C848619AF1D6C910A8EAC4B622FC06
65	0635E29D4E7AC8ABC189890241F45ECA
66	B272B020586AAD7B093AC2F459076638
67	B608ACE46E1A6BC96181EEDD88B54140
68	0A516092B3ED7849B168AFE223B8670E
69	D1A658C5009E04D0D7D5E9205EE663E8
70	AC316DC39B91EB60B1AABD8280740432
71	E3F06825476A026CD287625E514519FC
72	A56D092080DDE8994F387C175CC56833
73	15EA799DE587C506D0CD99A408217B05
74	A59C020BAB9AF6D3F813C391CA244CD2
75	74B0101EB9F3167434B94BABC8378882
76	CE752975C8DA9B0100386DB82A8C3D20

Code ID	Basic Midamble Codes of length 128
77	BBB38DCDB1E9118570AC147DC05241A4
78	944ABBF0866098101F6971731AB2E986
79	2BB147B2A30C68B4853F90481A166EB6
80	444840ACCF3F23C45B56D7704BF18283
81	87604F7450D1AD188C452981A5C7FC9B
82	8C3842EBC948A65BC4C8B387F11B7090
83	10B4767D071CF5DB2288E4029576135A
84	6F07AAB697CD0089572C6B062E2018E4
85	D3D65B442057E613A8655060C8D29E27
86	5EDA330514C604BF4E0894E09EC57A74
87	B0899CD094060724DED82AE85F18A43A
88	B2D999B86DF902BC25015CAE3A0823C4
89	C23CD40F04242B92D46EED82CD9A9A18
90	D22DDCC5CB82960125DD24655F3C8788
91	54987218FBD99AE4340FD4C9458E9850
92	BE4341822997A7B11EA1E8A1A2767005
93	255200FBA6EE48E6DE0A82B0461B8D0F
94	6FBD58A663932423503690CF9C171701
95	D215033A4AA87EC1C232BAC7EDA09370
96	CA0959B01AE48E80204F1E4A3F29CE55
97	582043413B9B825903E3A3545ED59463
98	5016541922971C703D16E284CBDF633B
99	7347EF160A1733CA98D43608A83A920B
100	908B22AD433CCA00B3FD47C691F1A290
101	BB22A272FC6923DF1B43BA4118806570
102	0FA75C87474836B47DC7624D61193802
103	A22EBA0658A4D0FF1E9CA5030A65CC06
104	6C9C51CA15F1F4981F4C46180A6A6697
105	4C847ACF8BC15359C405322851C9BDE2
106	C1D29499C0082C9DE473ED15B14D63E0
107	7E85ECC98AC761005076C5572869A431
108	D8F11121595B8F49F78A7039E44126A0
109	1A0BC814445FD71C8E5B1A9163ED2059
110	A7591F27F8B0C00C68CC41697954FA04
111	6CA2CE595E7406D79C4840183D41B9D0
112	C093D3CC701FC20E66F5AB22516C5460
113	D0E0CDE9B595546B96C4F8066B469020
114	E99F743A451431C8B427054A4E6F2007
115	C0D21A344A2C07DF2A6EBE6250C7B91E
116	F031223E282CF7A4D8EF174A908668AE
117	E4BD244AC16C55C7137FB068FD44280C
118	C44920DE2028F19FC2AAB36A0DCFDAD0
119	3FA7054E77135250699E6C8A11600742

Code ID	Basic Midamble Codes of length 128
120	D5740B4D8870C1C5B5A214C4266FC537
121	F0B7942D43BB6F38446442EB8126AB80
122	83DB9534EAD6238FA8968798CDF04848
123	EB9663CDDC2B291690703125BABC800
124	84D547225D4BBD20DEF1A583240C6E0F
125	B51F6A771838BE934724AEA6A2669802
126	D92AC05E10496794BBDC115233B1C068
127	D3ACF0078EDA9856BBB0AF8651132103

A.2 Association between Midambles and Channelisation Codes

The following mapping schemes apply for the association between midambles and channelisation codes if no midamble is allocated by higher layers. Secondary channelisation codes are marked with (*). These associations apply for both UL and DL.

A.2.1 Association for K=16 Midambles

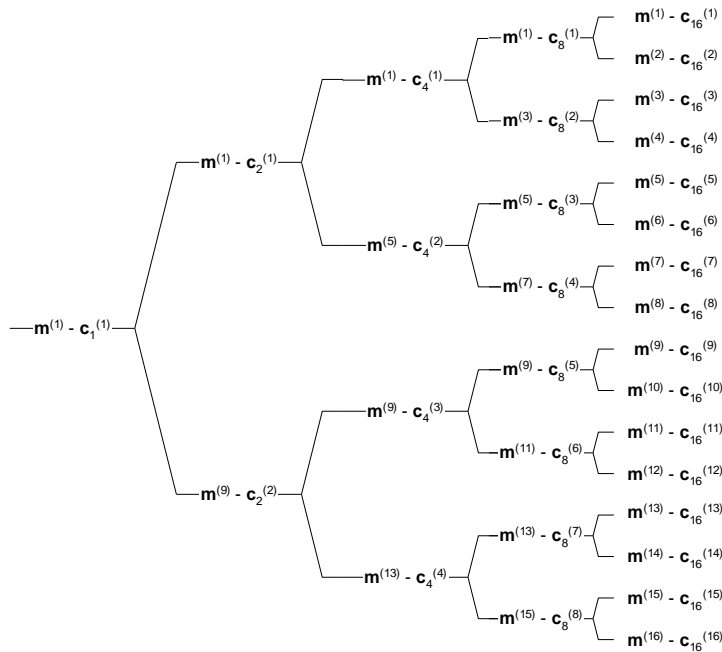

Figure A.1: Association of Midambles to Spreading Codes for K=16

A.2.2 Association for K=8 Midambles

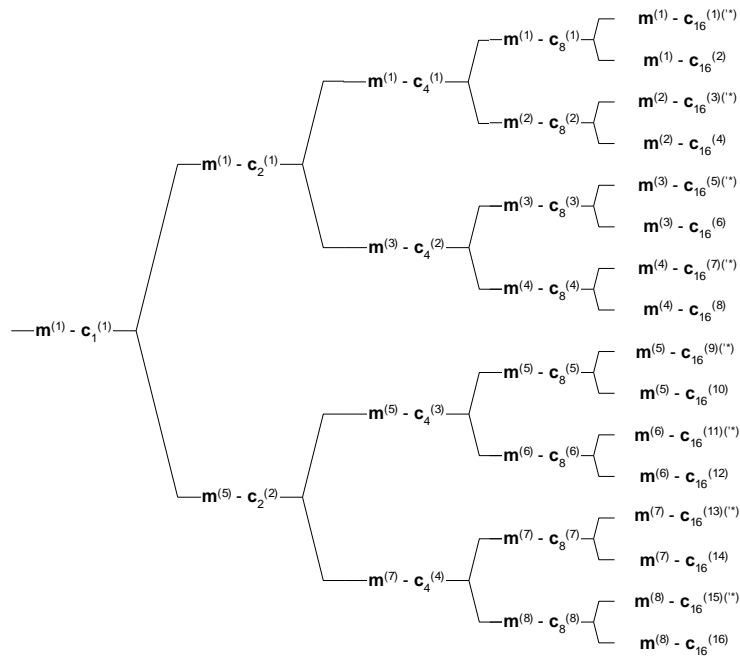

Figure A.2: Association of Midambles to Spreading Codes for K=8

A.2.3 Association for K=4 Midambles

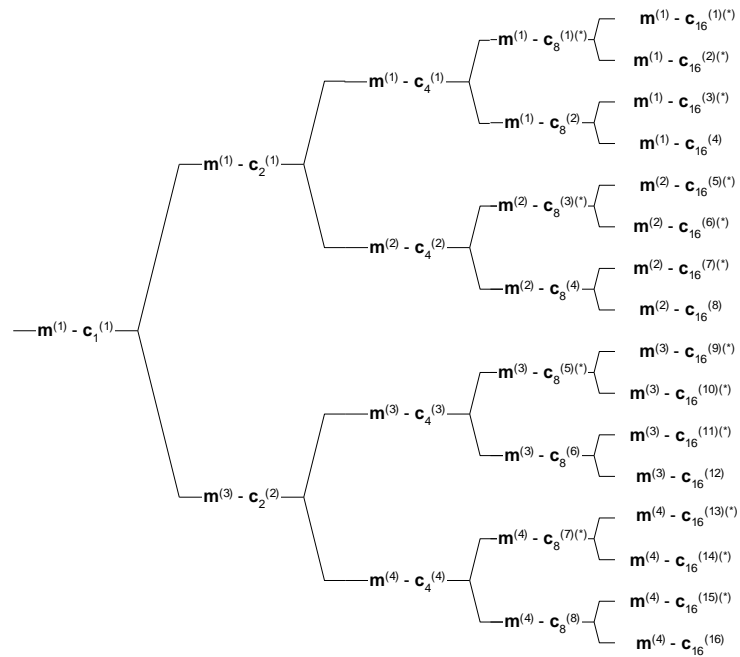

Figure A.3: Association of Midambles to Spreading Codes for K=4

A.2.4 Association for K=2 Midambles

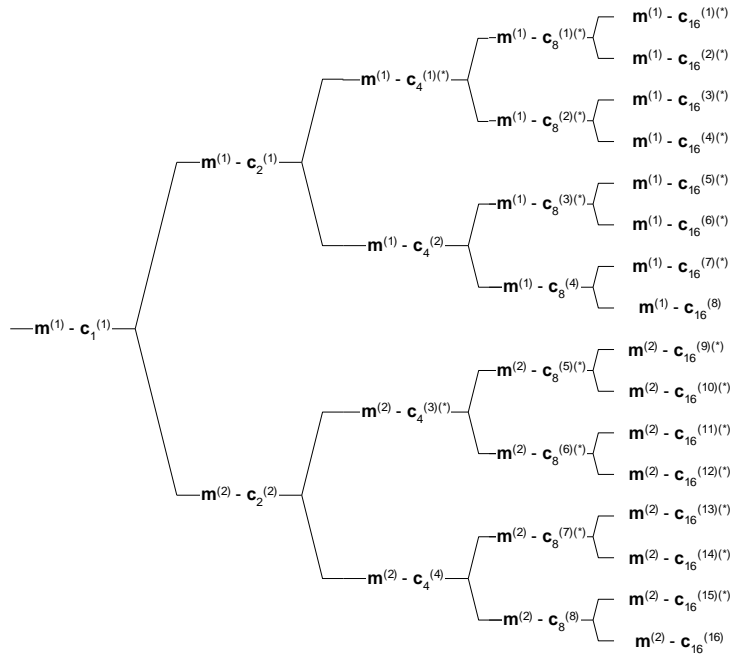

Figure A.4: Association of Midambles to Spreading Codes for K=2

A.2.5 Association for K=14 Midambles

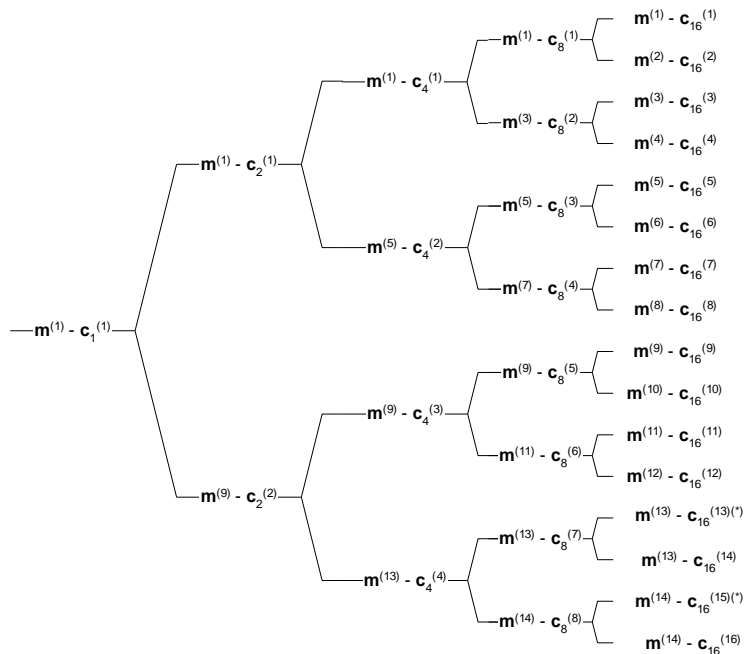

Figure A.5: Association of Midambles to Spreading Codes for K=14

A.2.6 Association for K=12 Midambles

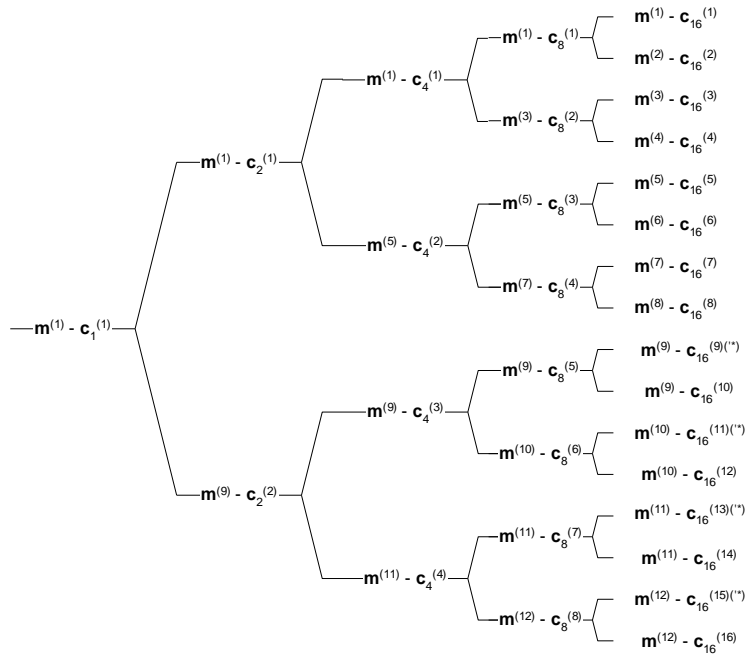

Figure A.6: Association of Midambles to Spreading Codes for K=12

A.2.7 Association for K=10 Midambles

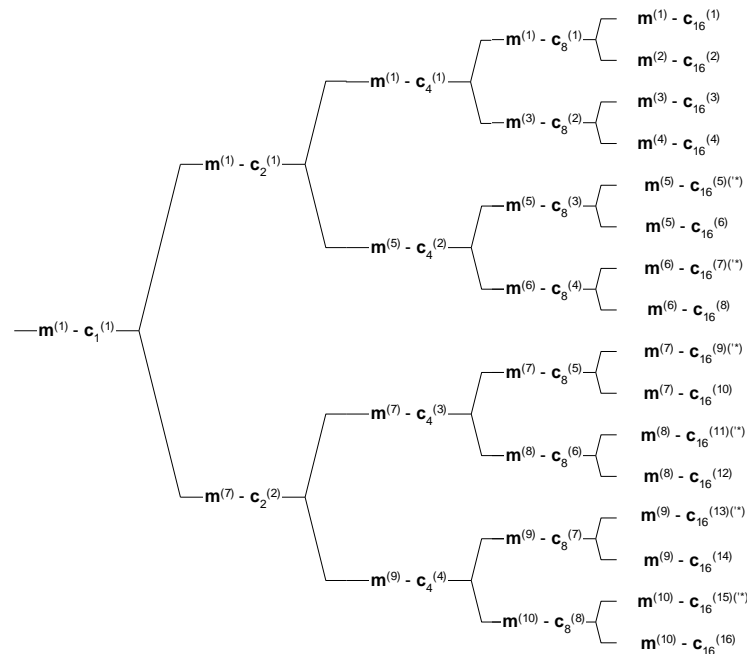

Figure A.7: Association of Midambles to Spreading Codes for K=10

A.2.8 Association for K=6 Midambles

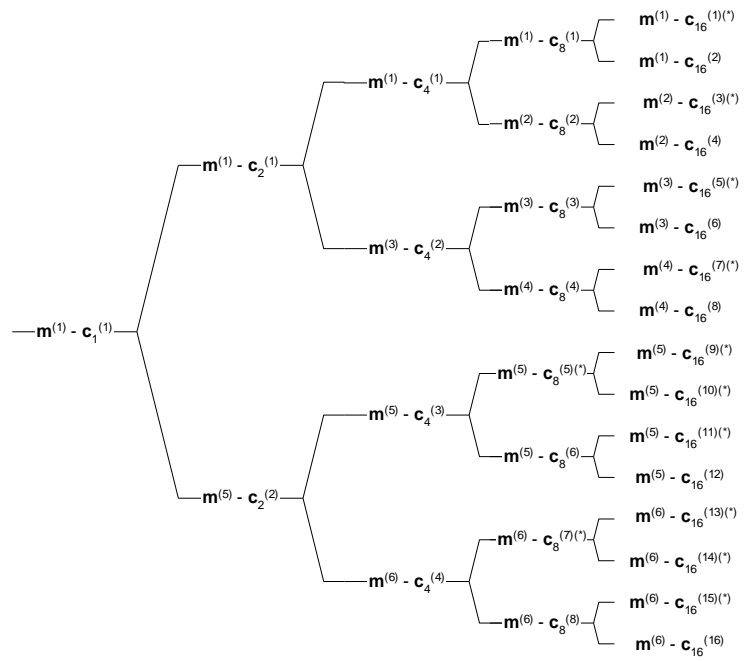

Figure A.8: Association of Midambles to Spreading Codes for K=6

Annex B (Informative): CCPCH Multiframe Structure

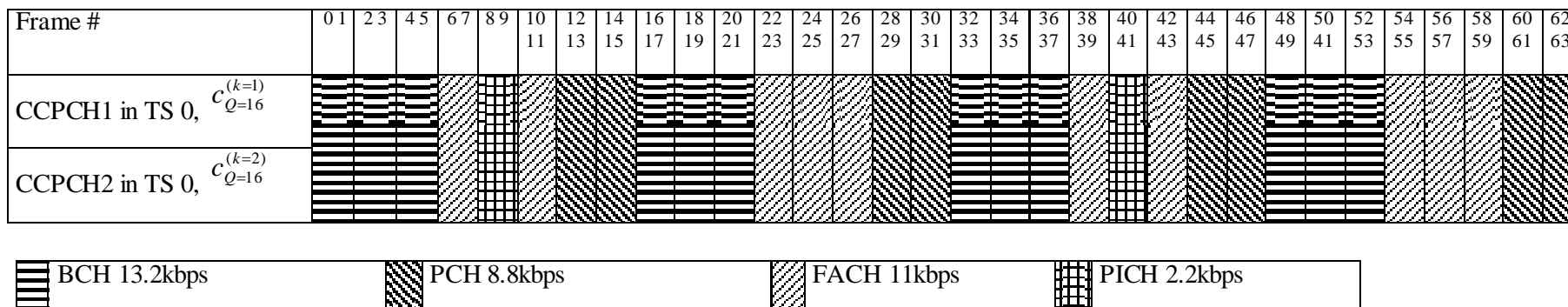

Figure B.1: Example for a multiframe structure for CCPCHs and PICH that is repeated every 64th frame (128 sub-frame)

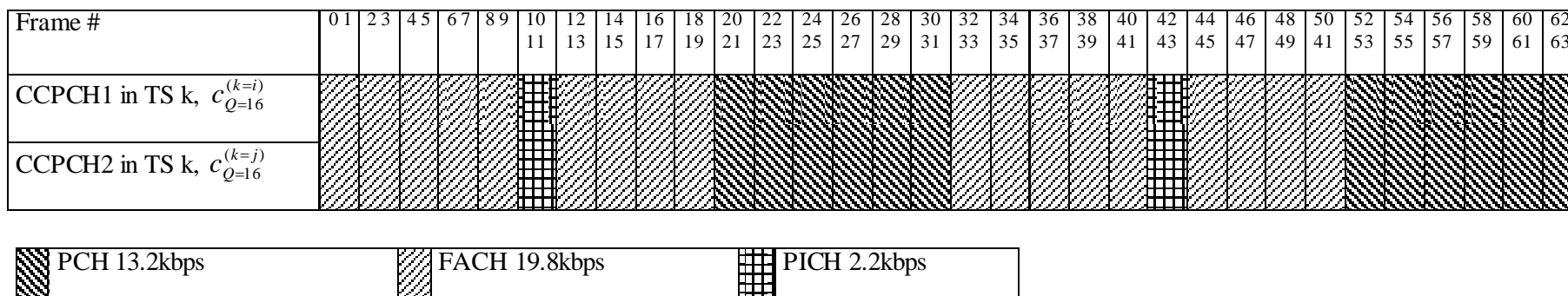

Figure B.2: Example for a multiframe structure for S-CCPCHs and PICH that is repeated every 64th frame, $i,j=1...16 (i \neq j), k \neq 0, 1, (128 \text{ sub-frame})$

Annex C (Informative): Examples of the association of DL TPC commands to UL uplink time slots for 1.28 Mcps TDD

Table C.1 Two examples of the association of DL TPC commands to UL uplink time slots with $N_{ULslot}=3$

Case 1: $N_{UL_TPCsymbols}=2$; Case 2: $N_{UL_TPCsymbols}=4$

Sub-Frame Number	Case 1 (2 UL TPC symbols)		The order of the served UL time slot and CCTrCH pairs (UL time slot and CCTrCH number)	Case 2 (4 UL TPC symbols)	
	The order of UL TPC symbols			The order of UL TPC symbols	
SFN'=0	(1 st UL _{pos} =0)	0	0 (TS3)	0	(1 st UL _{pos} =0)
		1	1 (TS4)	1	
		→	← 2 (TS5)	2	
			0 (TS3)	3	
SFN'=1	(1 st UL _{pos} =2)	0	← 0 (TS3)	0	(1 st UL _{pos} =1)
		1	← 1 (TS4)	1	
			← 2 (TS5)	2	
			← 0 (TS3)	3	
SFN'=2	(1 st UL _{pos} =1)	0	← 0 (TS3)	0	(1 st UL _{pos} =2)
		1	← 1 (TS4)	1	
			← 2 (TS5)	2	
			← 0 (TS3)	3	
		← 1 (TS4)			
		← 2 (TS5)			
.
.
.

Annex D (Informative): Examples of the association of DL SS commands to UL uplink time slots

In the following two examples of the association of DL SS commands to UL uplink time slots are shown (see 6.2.2.3):

Table D.1 Two examples of the association of DL SS commands to UL uplink time slots with $N_{ULslot}=3$

Case 1: $N_{SSsymbols}=2$; Case 2: $N_{SSsymbols}=4$

Sub-Frame Number	Case 1 (2 DL SS symbols)		The order of the served UL time slot (UL time slot number)	Case 2 (4 DL SS symbols)	
	The order of DL SS symbols			The order of DL SS symbols	
SFN'=0	(4^{st}) $UL_{pos}=0$	0	← 0 (TS3)	0	(1^{st}) $UL_{pos}=0$
		1	← 1 (TS4)	1	
			← 2 (TS5)	2	
			← 0 (TS3)	3	
SFN'=1	(1^{st}) $UL_{pos}=2$	0	← 0 (TS3)	0	(1^{st}) $UL_{pos}=1$
		1	← 1 (TS4)	1	
			← 2 (TS5)	2	
			← 0 (TS3)	3	
			← 1 (TS4)		
SFN'=2	(1^{st}) $UL_{pos}=1$	0	← 0 (TS3)	0	(1^{st}) $UL_{pos}=2$
		1	← 1 (TS4)	1	
			← 2 (TS5)	2	
			← 0 (TS3)	3	
			← 1 (TS4)		
			← 2 (TS5)		
.
.
.

Annex E (informative): Power Control

E.1 Example Implementation of Closed Loop Uplink Power Control in Node B for 1.28 Mcps TDD

The measurement of received SIR shall be carried out periodically at Node B. When the measured value is higher than the target SIR value, TPC command = "down". When the measurement is lower than or equal to the target SIR, TPC command = "up".

In case of an uplink transmission pause on DPCH, the initial uplink transmission power of DPCH after the pause can be determined by an open loop power control. After the initial transmission after the pause, a closed loop uplink power control procedure can resume.

E.2 Example Implementation of Downlink Power Control in UE for 1.28 Mcps TDD when TSTD is used

When TSTD is applied, the UE can use the consecutive measurements of SIR to calculate SIR_{AVG} :

$$SIR_{AVG}(i) = w_1 \Delta SIR(i-1) + w_2 \Delta SIR(i),$$

where, $w_1 + w_2 = 1$, $w_1 \geq 0$, $w_2 \geq 0$, and $SIR(i)$ is the measurement of SIR in sub-frame i and $SIR_{AVG}(i)$ is the measurement of SIR_{AVG} in sub-frame i . If SIR_{AVG} is greater than the target SIR value, TPC command = "down". If the SIR_{AVG} is smaller than the target SIR value, TPC command = "up".

In case of a downlink transmission pause on the DPCH, the example in Annex A.2 can be used for DL power control with $RSCP_{virt}(i)$ and $ISCP(i)$ replaced by $RSCP_{AVG}(i)$ and $ISCP_{AVG}(i)$, where

$$RSCP_{AVG}(i) = w_1 \Delta RSCP_{virt}(i-1) + w_2 \Delta RSCP_{virt}(i),$$

$$ISCP_{AVG}(i) = w_1 \Delta ISCP(i-1) + w_2 \Delta ISCP(i).$$

E.3 Example Implementation of open Loop Power Control for access procedure for 1.28 Mcps TDD

The higher layer signals (on BCH) a power increment that is applied only for the access procedure. At each new transmission of a SYNC_UL burst during the access procedure, the transmit power level can be increased by this power increment.

Annex F (informative): Examples random access procedure for 1.28Mcps TDD

F.1 Examples random access procedure for 1.28Mcps TDD

Table F.1: Single burst RACH WT=4, L =1, SF4 PRACH

Sub-frame Number	0	1	2	3	4	5	6	7	8	9	10
Users sending on UpPCH	1	3	5	7							
	2	4	6	8							
Acknowledged user on FPACH		1	2	3	4	5	6	7			
User sending RACH 0				1	2	3	4	5	6	7	

User 8 is not granted because more than 5 frames would have passed since the UpPCH.

Table F.2: Two burst RACH WT=4, L =2, SF8 RACH

Sub-frame Number	0	1	2	3	4	5	6	7	8	9	10	11
Users sending on UpPCH	1	3	5	7								
	2	4	6	8								
Acknowledged user on FPACH		1	2	3	4	5	6	7				
User sending RACH 0					2	2	4	4	6	6		
User sending RACH 1					1	1	3	3	5	5	7	7

User 8 is not granted because more than 5 frames would have passed since the UpPCH.

Table F.3: four burst RACH WT=4, L =4, SF16 RACH

Sub-frame Number	0	1	2	3	4	5	6	7	8	9	10	11	12	13
Users sending on UpPCH	1	3	5	7										
	2	4	6	8										
Acknowledged user on FPACH		1	2	3	4	5	6	7						
User sending RACH 0							4	4	4	4				
User sending RACH 1					1	1	1	1	5	5	5	5		
User sending RACH 2					2	2	2	2	6	6	6	6		
User sending RACH 3							3	3	3	3	7	7	7	7

User 8 is not granted because more than 5 frames would have passed since the UpPCH.

Table F.4: four burst RACH WT=4, L =4, SF16 RACH

Sub-frame Number	0	1	2	3	4	5	6	7	8	9	10	11	12
Users sending on UpPCH	1	3	5	7									
	2	4	6	8									
Acknowledged user on FPACH	X	1			2	3			X	X			
User sending RACH 0							2	2	2	2			
User sending RACH 1					1	1	1	1	3	3	3	3	

The FPACH is used ONLY in sub-frames 0, 1, 4, 5, 8, 9,... because they correspond to the used RACH resources.

The FPACH in sub-frame 0 is not used because no UpPCH is preceding.

The FPACH in sub-frames 8,9 is not used because no UpPCH is preceding in the last 4 sub-frames.

In contrast to the previous examples users 4,5,6,7 are not granted because they would no lead to a RACH anyway. In this example their grand would come too late.

User 8 is not granted because more than 4 frames would have passed since the UpPCH.

Annex G (informative): Monitoring GSM from low chip rate TDD: Calculation Results

[Description:]

This paper gives some general description about how to monitor GSM from the low chip rate TDD.

[Rationale:]

G.1 Low data rate traffic using 1 uplink and 1 downlink slot

NOTE: The section evaluates the time to acquire the FCCH if all idle slots are devoted to the tracking of a FCCH burst, meaning that no power measurements is done concurrently. The derived figures are better than those for GSM. The section does not derive though any conclusion. A conclusion may be that the use of the idle slots is a valid option. An alternative conclusion may be that this is the only mode to be used, removing hence the use of the slotted frames for low data traffic or the need for a dual receiver, if we were to considering the monitoring of GSM cells only, rather than GSM, TDD and FDD.

If a single synthesiser UE uses only one uplink and one downlink slot, e.g. for speech communication, the UE is not in transmit or receive state during 5 slots in each frame. According to the timeslot numbers allocated to the traffic, this period can be split into two continuous idle intervals A and B as shown in the figure below.

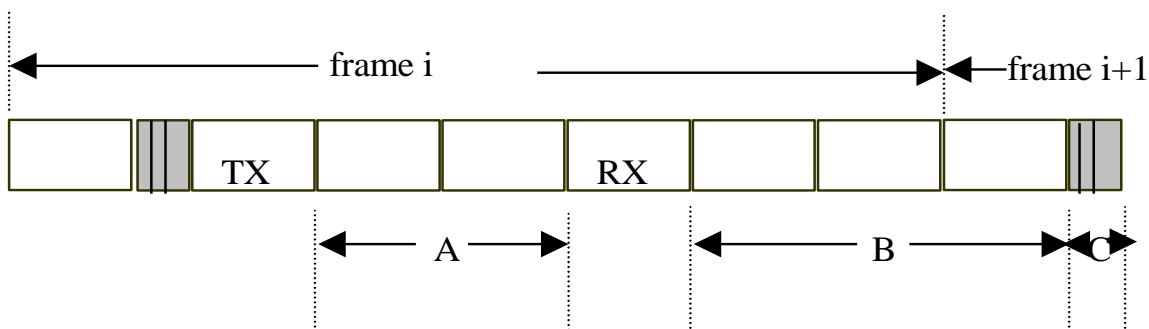

Figure G.1: Possible idle periods in a subframe with two occupied timeslots

A is defined as the number of idle slots between the Tx and Rx slots and B the number of idle slots between the Rx and Tx slots. It is clear that $A+B=5$ time slots and C is equal to the $DwPTS+GP+UpPTS$.

In the scope of low cost terminals, a [0.5] ms period is supposed to be required to perform a frequency jump from low chip rate TDD to GSM and vice versa. This lets possibly two free periods of $A*Ts-1$ ms and $B*Ts+C-1$ ms during which the mobile station can monitor GSM, Ts being the slot period.

Following table evaluates the average synchronisation time and maximum synchronisation time, where the announced synchronisation time corresponds to the time needed to find the FCCH. The FCCH is supposed to be perfectly detected which means that it is entirely present in the monitoring window. The FCCH being found the SCH location is unambiguously known from that point. All the 5 idle slots and the $DwPTS+GP+UpPTS$ are assumed to be devoted to FCCH tracking and the UL traffic is supposed to occupy the time slot 1.

Table G.1: example- of average and maximum synchronisation time with two busy timeslots per frame and with 0.5 ms switching time

Downlink time slot number	Number of free TS in A	Number of free TS in B	Average synchronisation time (ms)	Maximum synchronisation time (ms)
0	5	0	83	231
2	0	5	75	186
3	1	4	98	232
4	2	3	185	558
5	3	2	288	656
6	4	1	110	371

(*) All simulations have been performed with a random initial delay between GSM frames and low chip rate TDD subframes.

Each configuration of TS allocation described above allows a monitoring period sufficient to acquire synchronisation.

G.1.1 Higher data rate traffic using more than 1 uplink and/or 1 downlink TDD timeslot

The minimum idle time to detect a complete FCCH burst for all possible alignments between the GSM and the 1.28Mcps TDD frame structure (called 'guaranteed FCCH detection'), assuming that monitoring happens every sub-frame, can be calculated as follows (t_{FCCH} = one GSM slot):

$$t_{\text{min, guaranteed}} = 2 \times t_{\text{synth}} + t_{\text{FCCH}} + \frac{5\text{ms}}{13} = 2 \times t_{\text{synth}} + \frac{25\text{ms}}{26}$$

- (e.g for $t_{\text{synth}}=0\text{ms}$: 2 1.28Mcps TDD **consecutive** idle timeslots needed, for $t_{\text{synth}}=0.3\text{ms}$: 3 slots (or 2 slots and the DwPTS+GP+UpPTS), for $t_{\text{synth}}=0.5\text{ms}$: 3 slots, for $t_{\text{synth}}=0.8\text{ms}$: 4 slots). Under this conditions the FCCH detection time can never exceed the time of 660ms.
- (For a more general consideration t_{synth} may be considered as a sum of all delays before starting monitoring is possible).
- For detecting SCH instead of FCCH (for a parallel search) the same equation applies.
- In the equation before the dual synthesiser UE is included if the synthesiser switching time is 0ms.

Table G.1.1: FCCH detection time for a single synthesizer UE monitoring GSM from 1.28Mcps TDD every sub-frame

Occupied Slots	Cases	AVERAGE FCCH detection time in ms	MAXIMUM FCCH detection time in ms
2	21	136.625	660.785
3	35	188.451	660.785
4	35	231.115	660.785
5	21	-	-
6	7	-	-
7	1	-	-

The result in the above table is based on the following assumption:

- A single synthesizer is used.
- A [0.5] ms period is supposed to be required to perform a frequency jump from 1.28Mcps TDD to GSM and vice versa.
- For a given number of occupied slots in the TDD mode all possible cases of distributions of these occupied TDD slots are considered (see ‘cases’). For every case arbitrary alignments of the TDD and the GSM frame structure are taken into account for calculating the average FCCH detection time (only these cases are used which guarantee FCCH detection for all alignments; only the non-parallel FCCH search is reflected by the detection times in the above table).

The term ‘occupied slots’ means that the UE is not able to monitor in these TDD slots.

For a synthesiser switching time of one or one half TDD timeslot the number of needed consecutive idle TDD timeslots is summarized in the table below:

Table G.1.2: Link between the synthesiser performance and the number of free consecutive Timeslots for guaranteed FCCH detection, needed for GSM monitoring

One-way switching time for the synthesiser	Number of free consecutive 1.28Mcps TDD timeslots needed in the sub-frame for a guaranteed FCCH detection
1 Timeslot (=864 chips)	4
0.5 Timeslot (=432 chips)	3
0 (dual synthesiser)	2

[Explanation difference:]

Due to the different operating bandwidth and the different frame structure, some measurement method about how to monitor GSM are different between the high and low chip rate TDD.

Annex H: Performance analysis of the low chip rate

Simulation assumptions

Calculation of the E_b/N_0

Intercell interference is modeled as white Gaussian noise. In the following, bit error rates (BER) are given as a function of the average E_b/N_0 (or as a function of average C/I) in dB (E_b is the energy per bit and N_0 is the one-sided spectral noise density) with the intracell interference, i.e. the number K of active users per time slot as a parameter. The relation between the E_b/N_0 and the carrier to interference ratio C/I , with C denoting the carrier power per CDMA code and with I denoting the intercell interference power, is given by

$$\frac{C}{I} = \frac{E_b}{N_0} \cdot \frac{R_c \cdot \log_2 M}{B \cdot Q \cdot T_c} \quad (1.1)$$

with

R_c the rate of the channel encoder (depends on the service),

M the size of the data symbol alphabet (4),

B the user bandwidth

Q the number of chips per symbol (16) and

T_c the chip duration (0.78125 μ s).

The expression $\log_2 M$ is the number of bits per data symbol and $QxT_c/\log_2 M$ is the bit duration at the output of the encoder. One net information bit is transmitted in a duration of $QxT_c/(R_c \cdot \log_2 M)$. Therefore, (1.1) is equivalent to $C/I = (E_b/T_b)/(N_0 \cdot B)$, i.e., $C = E_b/T_b$ and $I = N_0 \cdot B$ with T_b the duration of a net information bit. The carrier to interference ratio per user is K_c times the carrier to interference ratio per CDMA code, with K_c denoting the number of CDMA codes per time slot per user.

The E_b/N_0 (as the C/I) is calculated at the antenna connector of the antenna elements.

Channel model

In case smart antennas are used the channel model is like the vehicular A model used for ITU and ETSI 30.03. The channel model has been adapted to the smart antenna environment such that the directions of arrival (DOA) for the multipaths are uniformly distributed.

Antenna array

Figure 1 shows the circular array used in smart antenna simulations. The circular array is suitable for omnidirectional cell design. Let the array be composed of N antenna elements, where the first (reference) antenna element is located at the position of $(R, 0)$, and the k -th element is located at the location of $(R \cos 2k\pi/N, R \sin 2k\pi/N)$ in circular array.

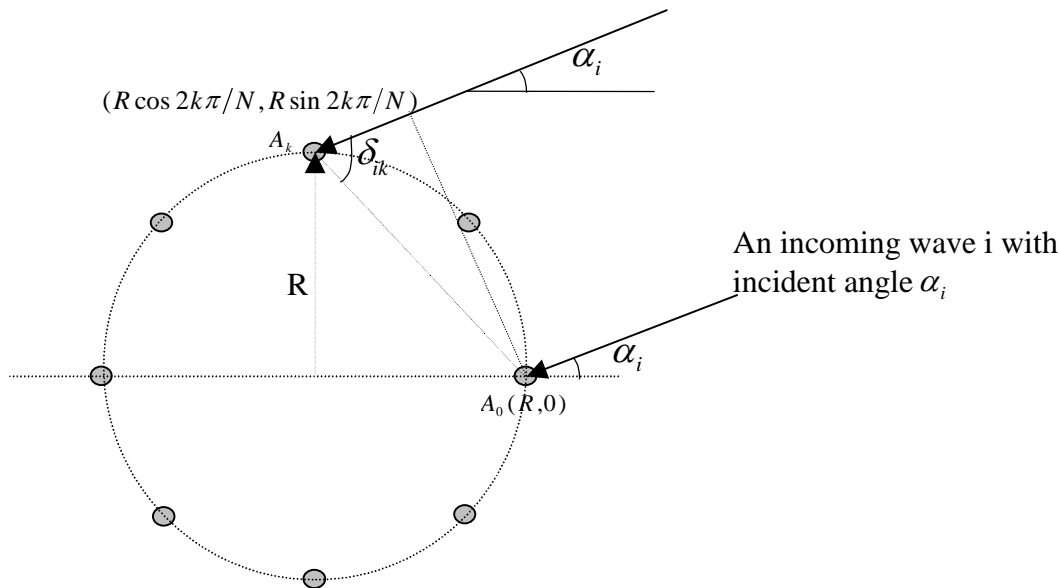

Figure H.1: The geometric illustration for circular antenna array

Then, when an incoming wave i from the direction of α_i , for circular array, the differential optical distance (D_{ik}) between the first and the k -th antenna element will be

$$D_{ik} = R \cos \delta_{ik} [2(1 - \cos 2k\pi/N)]^{1/2}$$

where R is the radius of the circular array;

$$k = 1, 2, \dots, N - 1;$$

N is the total number of antenna element.

The incident wave comes from the direction of α_i as shown in Figure 1, and

$$\delta_{ik} = \alpha_i + \pi(1/2 - k/N)$$

Let's denote $S_{kj}(n)$ as the Rx signal at the k -th antenna element from the i -th path of the j -th UE, then

$$S_{kj}(n) = \sum_i a_{ji}(n) \exp[-j(\omega\tau_{ji} + \varphi_{kji})] \quad \text{for the } n\text{-th sampling}$$

where, $a_{ji}(n)$ is the amplitude of the i -th path from the j -th UE;

τ_{ji} is the time delay of the i -th path from the j -th UE;

φ_{kji} is the phase different between the k -th element and the reference element for the i -th path from the j -th UE:

$$\varphi_{jik} = 2\pi D_{jik} / \lambda$$

and D_{jik} is the differential optical distance between the first and the k -th antenna element for the i -th path from the j -th UE;

ω is the angle frequency and λ is the wavelength.

Simulation results

Simulation for BCH

Simulation parameters:

Channel model: vehicular A (Speed 120km/h)

Coding: CC ,coding rate =1/3

Link: downlink

Power control: No

SF: 16

Number of timeslots: 1

Codes per slot: 2

L1 control signals: No

TFCI: No

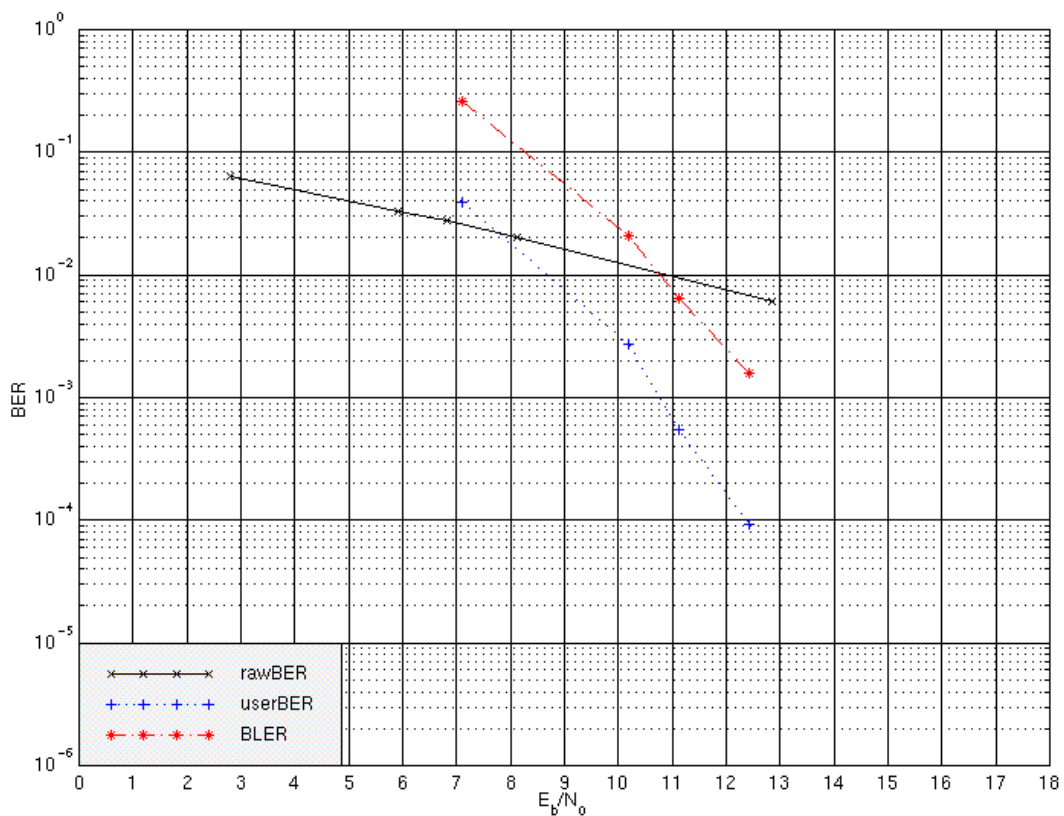

Figure H.2: BER vs. E_b/N_0 for BCH

Multiplexing of 12.2kbps data and 2.4kbps data

For 2.4kbps data path

Simulation parameters:

Channel model: vehicular A with Smart antenna (Speed 120km/h)

Coding: CC ,coding rate =1/2

Link: Uplink

Power control: No

SF:16

Number of users: 1

Number of time slot: 1

Codes per time slot: 3

L1 control signals: No

TFCI: No

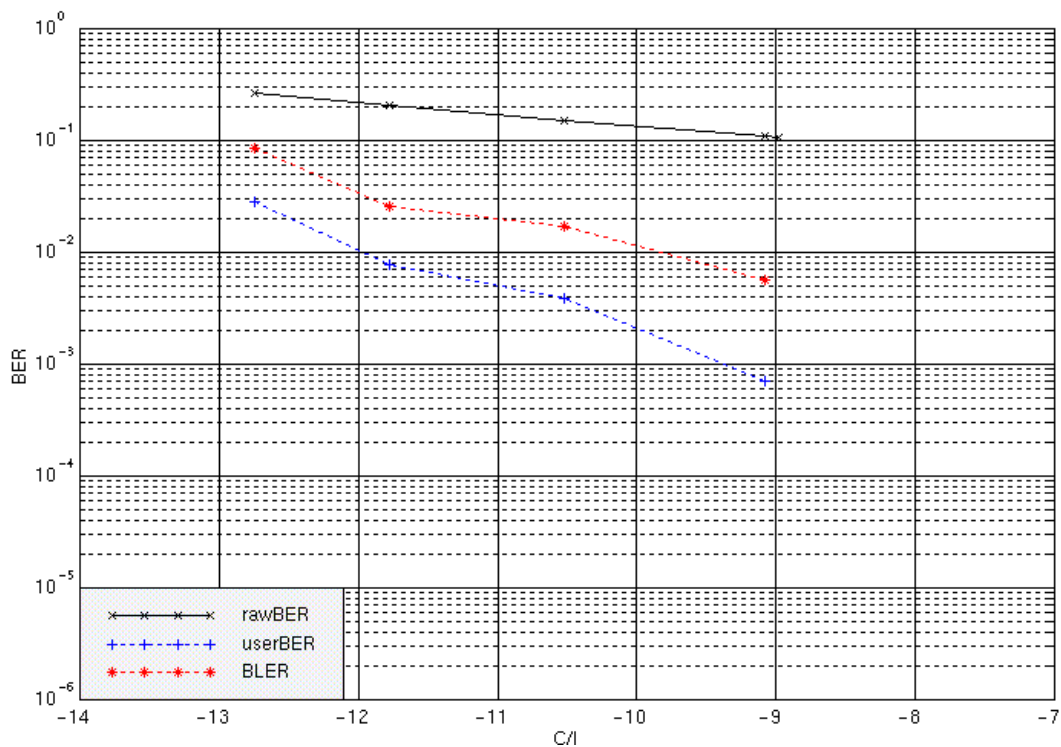

Figure H.3: BER vs. C/I for 2.4kbps path

For 12.2kbps data path

Simulation parameters:

Channel model: vehicular A with Smart antenna (Speed 120km/h)

Coding: CC ,coding rate=1/2,class C

CC, coding rate=1/3,class A and B

Link: Uplink

Power control: No

SF:16

Number of users: 1

Number of time slot: 1

Codes per time slot: 3

L1 control signals: 4 bits.

TFCI: 16 bits(8 bits per subframe).

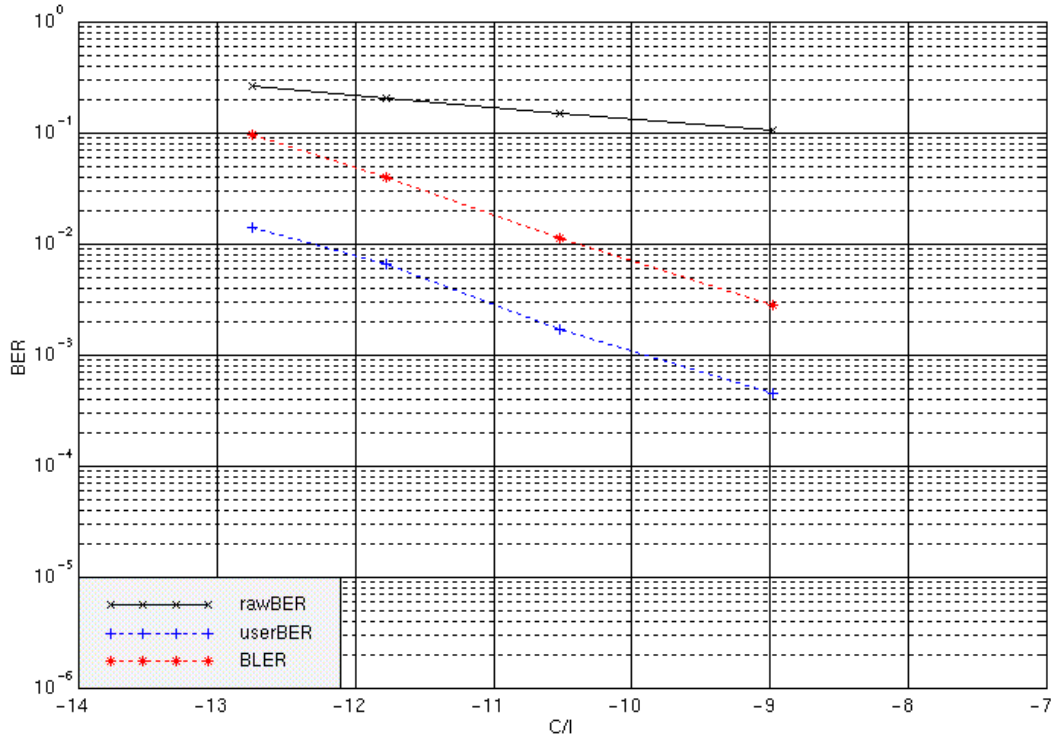

Figure H.4: BER vs. C/I for 12.2kbps path

Simulation for 384kbps

Simulation parameters:

Channel model: vehicular A with Smart antenna (Speed 120km/h)

Coding: Turbo coding ,coding rate 1/3. Convolutional code with code rate 1/3 is optional for 384kbps packet data.

Link: Uplink

Power control: No

SF:16

Number of users: 1

Number of time slot: 4

Codes per time slot: 16

L1 control signals: 4 bits.

TFCI: 16 bits

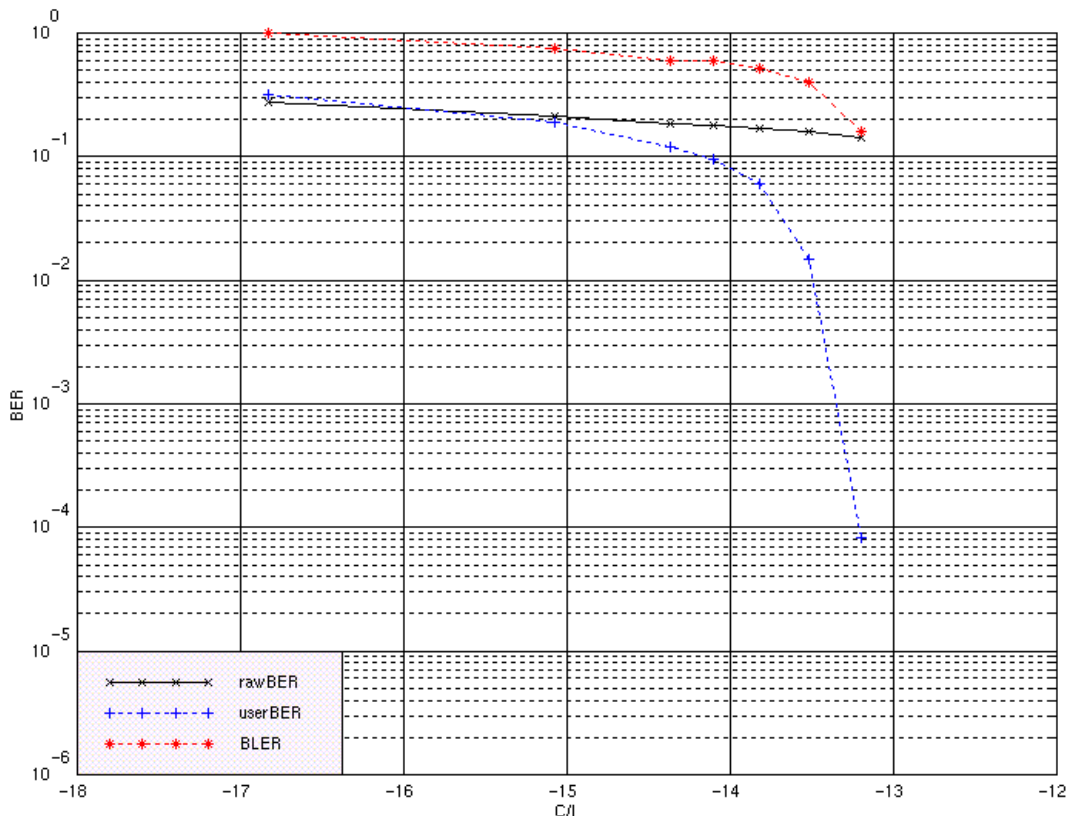

Figure H.5: BER vs. C/I for 384kbps

Simulation for 2Mbps

The simulations for the indoor environments in uplink are considered. The channel model is compatible with the one in UMTS 30.03. The main parameters are listed as following:

Parameters

Service: 2 Mbps service

Channel model: Indoor A

Channel coding: None

Modulation/Demodulation: 8PSK;

Power Control: Ideal power control

Frame structure: 5ms

Number of time slot: 5

Codes per time slot: 16

Simulation Results

The following table and figures in next pages present the simulation results for 2 Mbps service without channel coding considered.

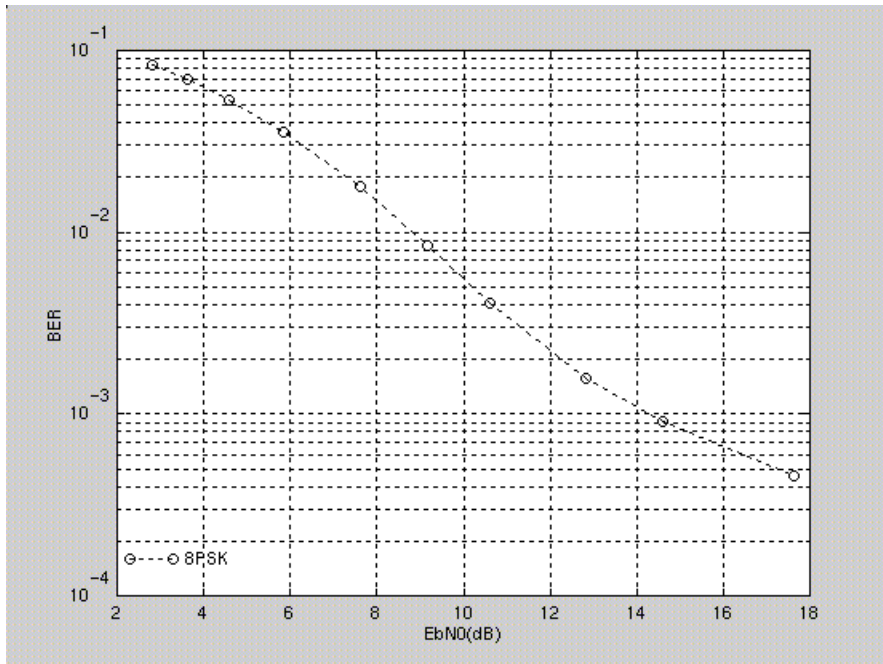

Figure H.6: BER vs. E_b/N_0 for 2 Mbps service

(without coding using 8PSK modulation scheme)

Annex I: Examples of service mapping

I.1 BCH

Table I.1: Parameters for BCH

Transport block size	246 bits
CRC	16 bits
Coding	CC, coding rate = 1/3 This has to be included in table 1 in 25.222 4.2.3.
TTI	20 ms
Midamble	144 chips
Codes and time slots	SF = 16 2 codes x 1 time slot
TFCI	0 bit
L1 control signals	0 bit

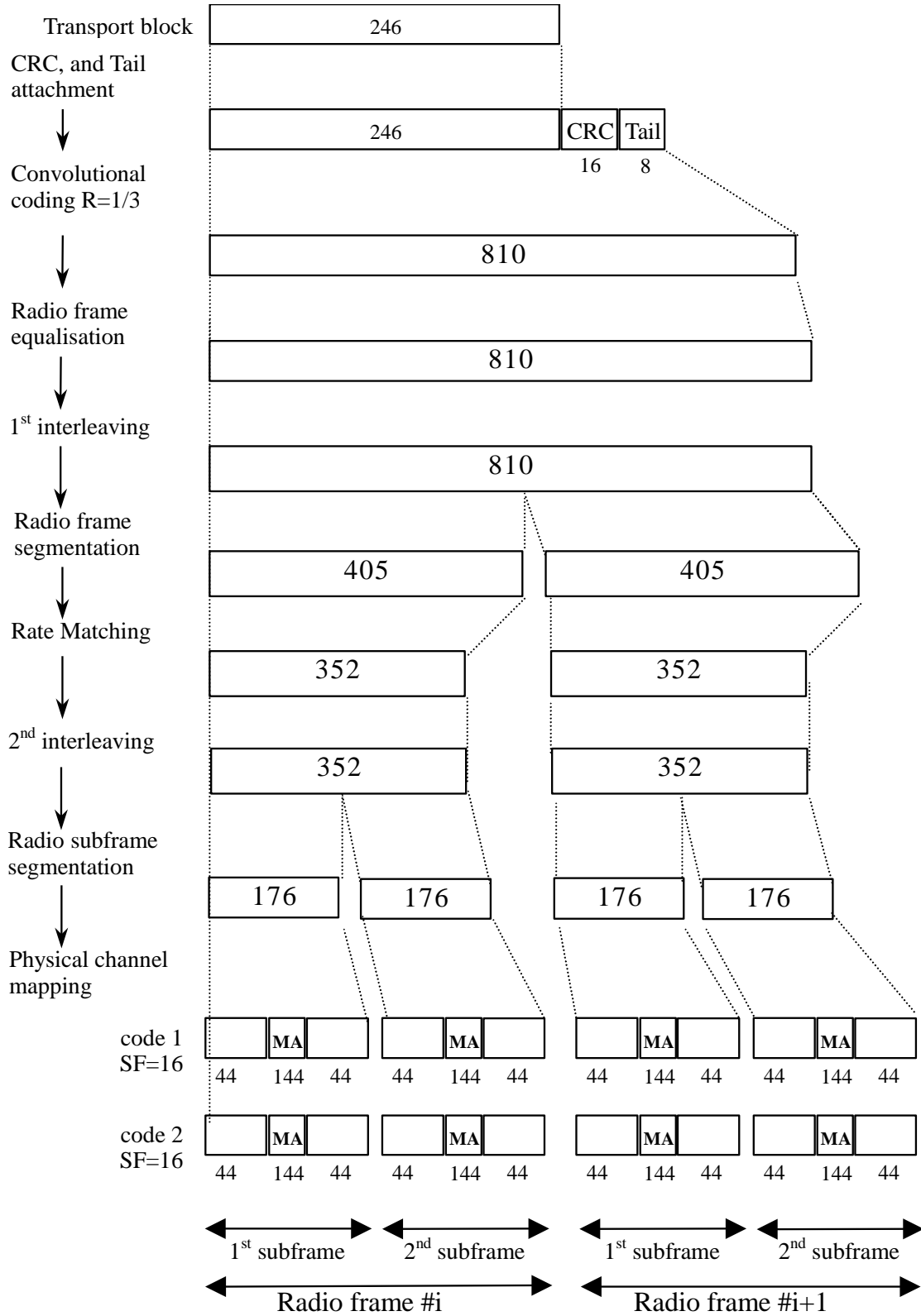

Figure I.1: Service mapping for BCH

I.2 2.4kbps data for downlink

Table I.2: Parameter examples for 2.4kbps data

Transport block set size	48 bits
CRC	16 bits
Coding	CC, coding rate = 1/2
TTI	20 ms

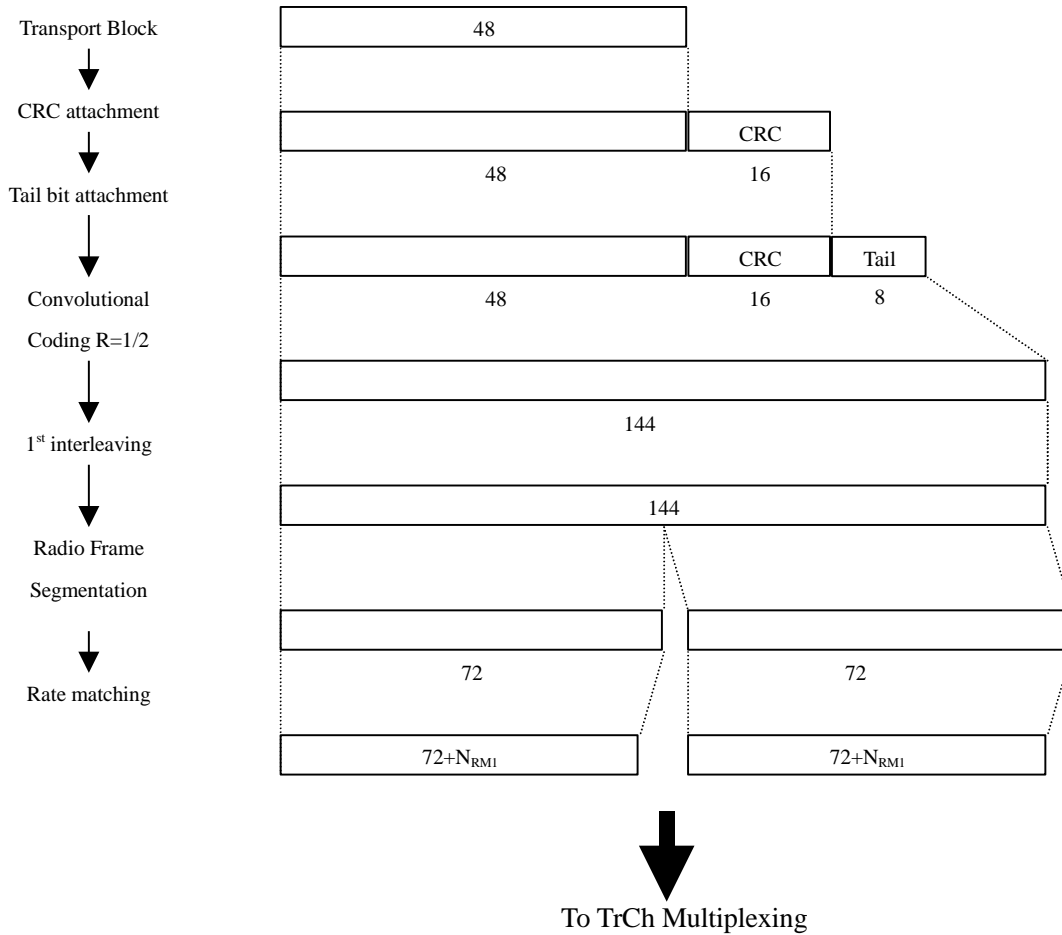

Figure I.2: Channel coding for 2.4kbps data

I.3 12.2kbps data for downlink

Note: this example can be applied to AMR speech

Table I.3: Parameter examples for 12.2kbps data

Number of TrChs	3
Transport block size	81bits (TrCh#1) 103bits (TrCh#2) 60bits (TrCh#3)
CRC	12(Only for TrCh#1)
Coding	CC, coding rate = 1/2, class B, C CC, coding rate = 1/3, class A
TTI	20 ms
Midamble	144 chips
Codes and time slots	SF = 16 2 codes x 1 time slots
TFCI	16bits (8 bits in each subframe)
L1 control signals	4bits

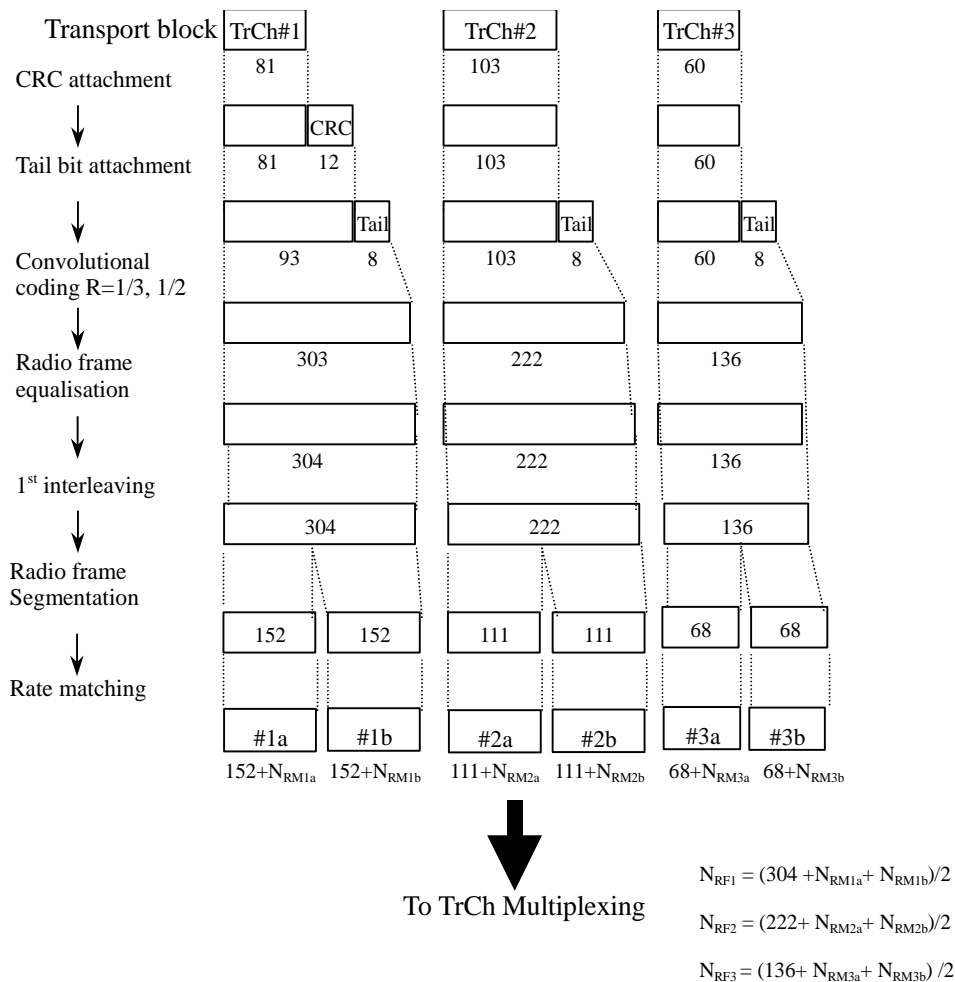
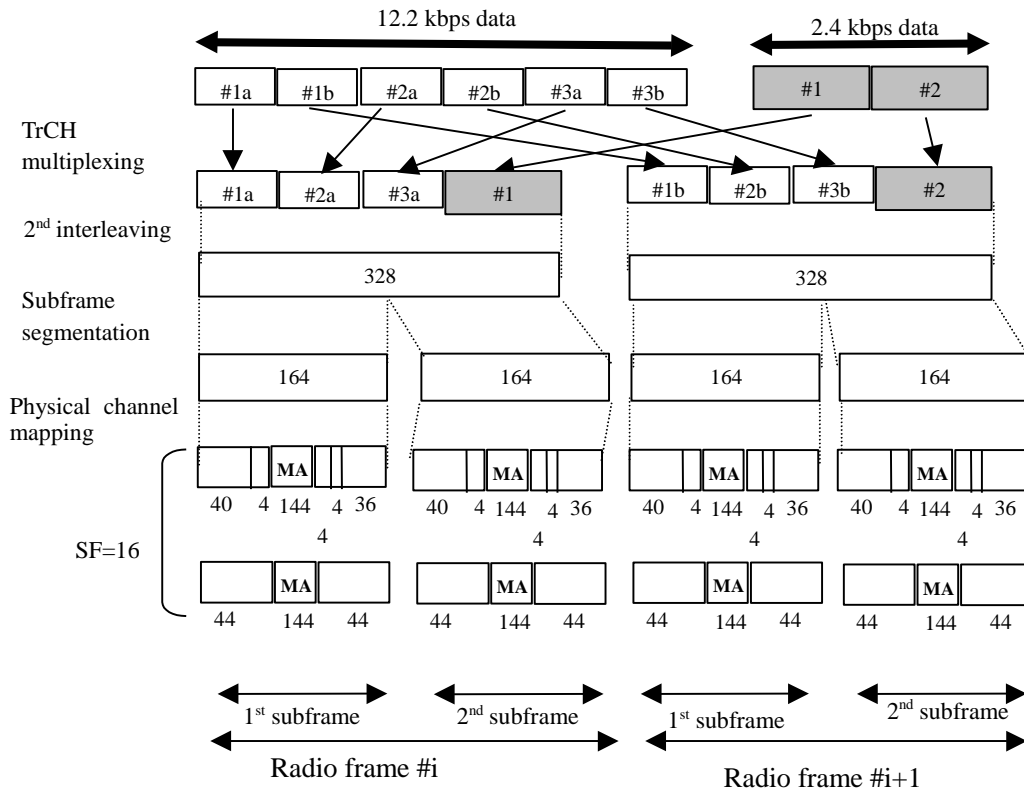

Figure I.3: Channel coding for 12.2kbps AMR

I.3.1 Example for multiplexing of 12.2 kbps data and 2.4 kbps data



I.4 384kbps packet data for downlink

Table I.4: Parameter examples for 384kbps packet data

The number of TrCHs	1
Transport block set size	3840*B bits (B=0,1,2)
Segmentation C	1 (B = 0, 1) or 2 (B = 2)
CRC	16 bits
Coding	Turbo coding, coding rate = 1/3
TTI	20 ms
Midamble	144chips
Codes and time slots	SF = 16 16 codes x 4 time slots
TFCI	16bits
L1 signals	4 bits

Note1: Convolutional code with code rate 1/3 is optional for 384kbps packet data if UE capability supports it. B=2 for the figure B.4.

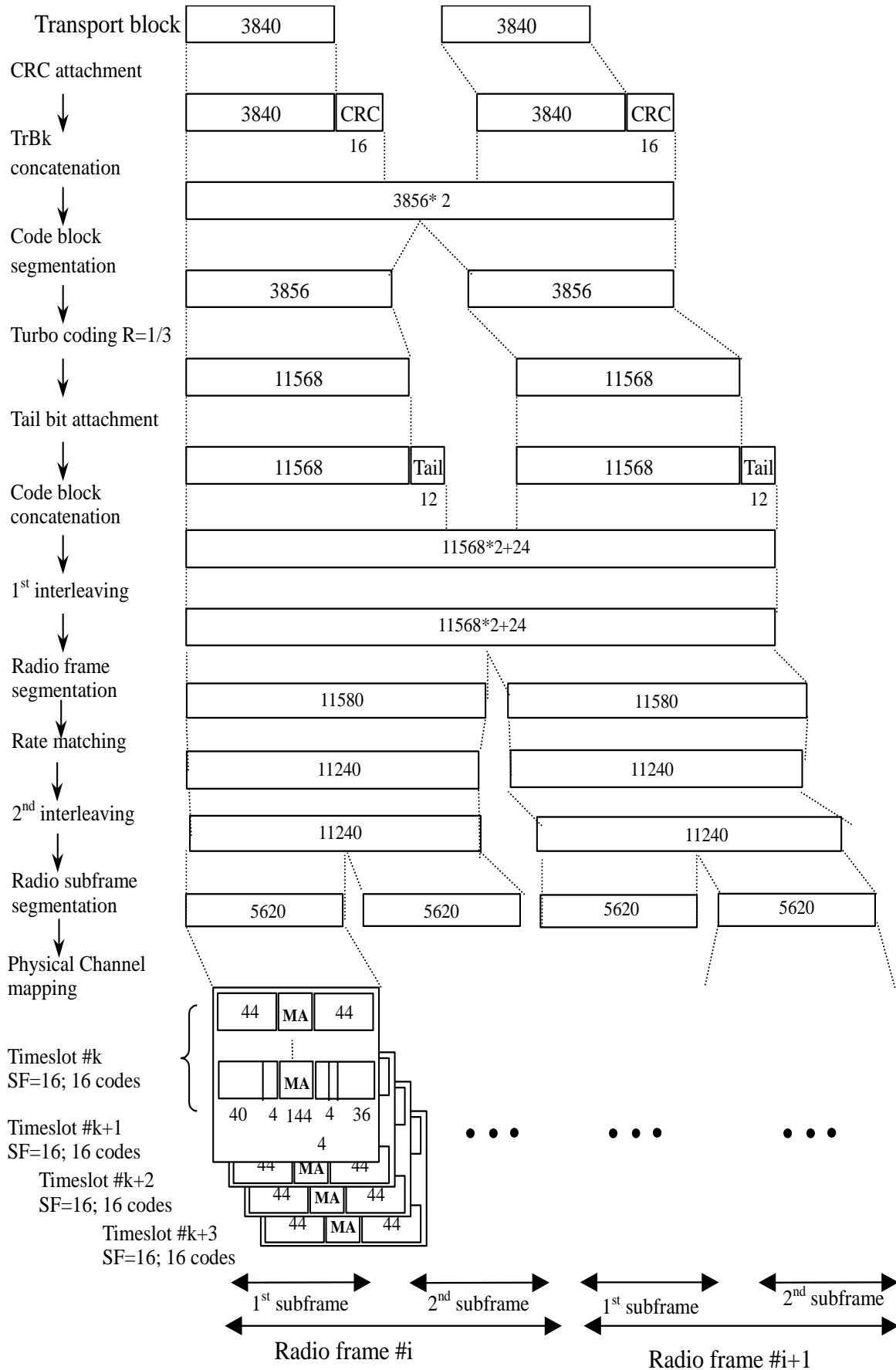

Figure I.4: Service mapping for 384kbps packet data

I.5 2Mbps packet data for downlink

In low chip rate TDD optional, 2Mbps service is only used in some special environment. E.g. Indoor environment

Table I.5: Parameter examples for 2Mbps packet data

Transport block size	20480*B bits(B=0,1)
CRC	24 bits
Coding	no
TTI	10 ms
Midamble	144 chips
Codes and time slots	SF = 1 1 codes x 5 time slots
TFCI	24bits
L1 control signals	6bits

Note1: 8PSK has to be used to provide 2Mbps packet data service. B=1 for the figure B.5.

Note2: other mapping schemes, e.g. using more resource unit and using some channel coding, or increasing the number of the code block segmentation to reduce BLER are considered.

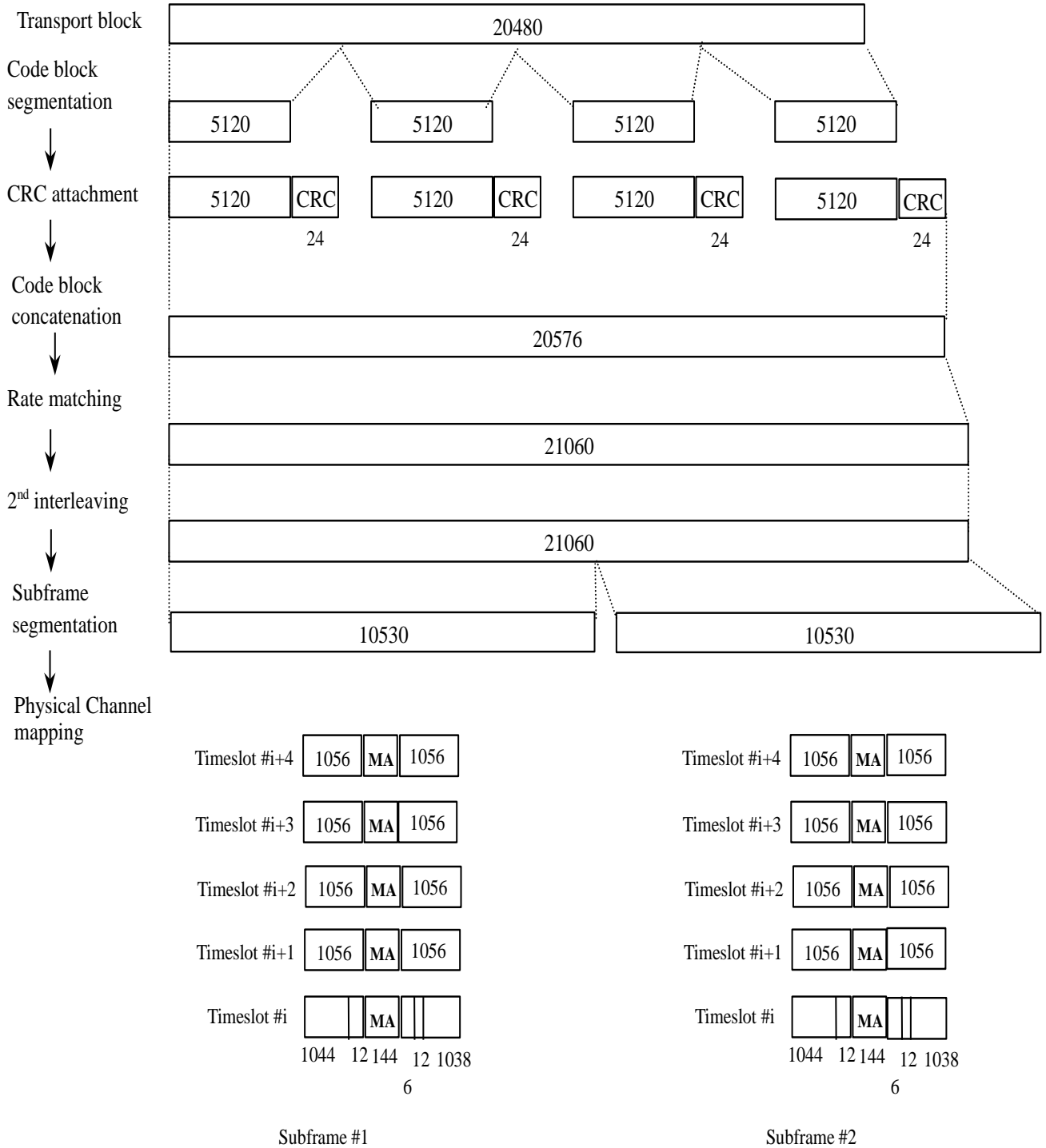

Figure I.5: Service mapping for 2Mbps packet data

Annex J (informative): Change history

Change history							
Date	TSG #	TSG Doc.	CR	Rev	Subject/Comment	Old	New
16/03/01	RAN_11	RP-010068	-	-	Approved at TSG RAN #11 and placed under Change Control	-	4.0.0
09/04/01	-	-	-	-	Editorial correction in terms of formatting (MCC)	4.0.0	4.0.1