

**3rd Generation Partnership Project;
Technical Specification Group Radio Access Network;
Radio resource management strategies
(Release 7)**



The present document has been developed within the 3rd Generation Partnership Project (3GPPTM) and may be further elaborated for the purposes of 3GPP.

The present document has not been subject to any approval process by the 3GPP Organisational Partners and shall not be implemented. This Specification is provided for future development work within 3GPP only. The Organisational Partners accept no liability for any use of this Specification. Specifications and reports for implementation of the 3GPPTM system should be obtained via the 3GPP Organisational Partners' Publications Offices.

Keywords

UMTS, radio, management

3GPP

Postal address

3GPP support office address

650 Route des Lucioles - Sophia Antipolis
Valbonne - FRANCE
Tel.: +33 4 92 94 42 00 Fax: +33 4 93 65 47 16

Internet

<http://www.3gpp.org>

Copyright Notification

No part may be reproduced except as authorized by written permission.
The copyright and the foregoing restriction extend to reproduction in all media.

© 2007, 3GPP Organizational Partners (ARIB, ATIS, CCSA, ETSI, TTA, TTC)
All rights reserved.

Contents

Foreword	7
1 Scope	8
2 References.....	8
3 Definitions and abbreviations	9
3.1 Definitions	9
3.2 Abbreviations	9
4 Idle Mode Tasks	11
4.1 Overview	11
4.2 Service type in Idle mode	11
4.3 Criteria for Cell Selection and Reselection	12
4.3.1 Cell Selection	12
4.3.2 Cell Re-selection	12
4.3.2.1 Hierarchical Cell Structures	12
4.3.2.2 Measurements for cell re-selection	13
4.3.2.3 Cell re-selection criteria	13
4.3.3 Mapping of thresholds in cell reselection rules	14
4.3.4 Barred / Reserved Cells and Access Restrictions for Cells	14
4.3.4.1 Barred cells	14
4.3.4.2 Reserved cells	14
4.3.4.3 Access Restrictions for Cells	14
4.4 Location Registration	15
5 RRC Connection Mobility	15
5.1 Handover.....	15
5.1.1 Strategy	15
5.1.2 Causes	15
5.1.3 Hard Handover	16
5.1.4 Soft Handover	16
5.1.4.1 Soft Handover Parameters and Definitions	16
5.1.4.2 Example of a Soft Handover Algorithm	16
5.1.4.3 Soft Handover Execution	17
5.1.5 Inter Radio Access Technology Handover	18
5.1.5.0 General.....	18
5.1.5.1 Handover UTRAN to GSM	19
5.1.5.2 Handover GSM to UTRAN	19
5.1.5.2.1 Introduction.....	19
5.1.5.2.2 Predefined radio configuration information	19
5.1.5.2.3 Security and UE capability information	20
5.1.5.2.4 UE capability information	20
5.1.5.2.5 Handover to UTRAN information flows, typical example	20
5.1.5.3 Handover from UTRAN to GERAN Iu mode	25
5.1.5.4 Handover from GERAN Iu mode to UTRAN	26
5.1.6 Measurements for Handover.....	26
5.1.6.1 Monitoring of FDD cells on the same frequency	26
5.1.6.2 Monitoring cells on different frequencies.....	26
5.1.6.2.1 Monitoring of FDD cells on a different frequency	26
5.1.6.2.2 Monitoring of TDD cells	26
5.1.6.2.2.2 Void	26
5.1.6.2.3 Monitoring of GSM cells	26
5.1.7 Transfer of RRC information across interfaces other than Uu.....	28
5.1.7.1 Introduction and general principles	28
5.1.7.2 Message sequence diagrams	29
5.1.7.3 General error handling for RRC containers	36

6	Admission Control	42
6.1	Introduction	42
6.2	Examples of CAC strategies	42
6.2.1	CAC for handover.....	43
6.3	Scenarios	43
6.3.1	CAC performed in SRNC	43
6.3.2	CAC performed in DRNC	44
6.3.2.1	Case of DCH.....	44
6.3.2.2	Case of Common Transport Channels	44
7	Radio Bearer Control.....	45
7.1	Usage of Radio Bearer Control procedures	45
7.1.1	Examples of Radio Bearer Setup.....	45
7.1.2	Examples of Physical Channel Reconfiguration.....	46
7.1.2.1	Increased UL data, with switch from CELL_FACH to CELL_DCH	46
7.1.2.2	Increased DL data, no Transport channel type switching	47
7.1.2.3	Decrease DL data, no Transport channel type switching	47
7.1.2.4	Decreased UL data, with switch from CELL_DCH to CELL_FACH	47
7.1.3	Examples of Transport Channel Reconfiguration	48
7.1.3.1	Increased UL data, with no transport channel type switching	48
7.1.4	Examples of Radio Bearer Reconfiguration	48
8	Dynamic Resource Allocation.....	50
8.1	Code Allocation Strategies for FDD mode	50
8.1.1	Introduction.....	50
8.1.2	Criteria for Code Allocation.....	50
8.1.3	Example of code Allocation Strategies	51
8.1.4	Void	52
8.2	DCA (TDD).....	52
8.2.1	Channel Allocation	52
8.2.1.1	Resource allocation to cells (slow DCA).....	52
8.2.1.2	Resource allocation to bearer services (fast DCA)	53
8.2.2	Measurements Reports from UE to the UTRAN.....	53
9	Power Management.....	54
9.1	Variable Rate Transmission.....	54
9.1.1	Examples of Downlink Power Management	54
9.1.2	Examples of Uplink Power Management	54
9.2	Void	54
9.3	Examples of balancing Downlink power	55
9.3.1	Adjustment loop.....	55
10	Radio Link Surveillance	55
10.1	Mode Control strategies for TX diversity	55
10.1.1	TX diversity modes.....	55
10.1.2	Mode Control Strategies	55
10.1.2.1	DPCH.....	55
10.1.2.2	Common channels	56
11	Codec mode control	56
11.1	AMR mode control.....	56
12	Congestion Control	59
12.1	Introduction.....	59
12.2	Example of Congestion Control procedures.....	59
13	High Speed Downlink Packet Access	59
13.1	HSDPA scheduling	59
13.1.1	Introduction.....	59
13.1.2	Scheduling strategies.....	60
13.1.2.1	Non real-time services	60
13.1.2.2	Real time / near real-time services.....	60
14	Multimedia Broadcast Multicast Service (MBMS)	62
14.1	Introduction	62

14.2	MBMS in UTRAN	62
14.2.1	Mapping of MBMS bearer to p-t-p and p-t-m channels	62
14.2.2	MBMS counting	62
14.2.3	MBMS RRM p-t-p / p-t-m switching strategies.....	63
Annex A: Simulations on Fast Dynamic Channel Allocation.....		65
A.1	Simulation environment	65
A.2	Results	65
A.2.1	Void	65
A.2.2	Micro UDD 384.....	65
A.2.2.1	Code rate 1	66
A.2.2.2	Code rate 2/3.....	66
A.3	Conclusions	67
Annex B: Radio Bearer Control – Overview of Procedures: message exchange and parameters used.....		67
B.1	Examples of Radio Bearer Setup	67
B.1.1	RRC Parameters in RB Setup	67
B.1.2	Void	68
B.2	Examples of Physical Channel Reconfiguration	68
B.2.1	Increased UL data, with switch from CELL_FACH to CELL_DCH	68
B.2.1.1	RRC Parameters in Measurement Report	68
B.2.1.2	RRC Parameters in Physical Channel Reconfiguration	68
B.2.1.3	Void	69
B.2.2	Increased DL data, no Transport channel type switching	69
B.2.2.1	RRC Parameters in Physical Channel Reconfiguration	69
B.2.2.2	Void	69
B.2.3	Decrease DL data, no Transport channel type switching	69
B.2.3.1	RRC Parameters in Physical Channel Reconfiguration	70
B.2.3.2	Void	70
B.2.4	Decreased UL data, with switch from CELL_DCH to CELL_FACH.....	70
B.2.4.1	RRC Parameters in Physical Channel Reconfiguration	70
B.2.4.2	Void.....	70
B.3	Examples of Transport Channel Reconfiguration.....	70
B.3.1	Increased UL data, with no transport channel type switching	70
B.3.1.1	RRC Parameters in Measurement Report	71
B.3.1.2	RRC Parameters in Transport Channel Reconfiguration	71
B.3.1.3	Void.....	72
B.3.2	Void	72
B.3.2.1	Void	72
B.3.2.2	Void.....	72
B.4	Examples of RB Reconfiguration	72
B.4.1	RRC Parameters in Radio Bearer Reconfiguration	72
B.4.2	Void	72
Annex C: Flow-chart of a Soft Handover algorithm		73
Annex D: Void		74
Annex E: Simulation results on DL Variable Rate Packet Transmission		75
E.1	Simulation assumption	75
E.2	Simulation results	75
Annex F: Simulation results on Adjustment loop.....		77
F.1	Simulation conditions	77
F.2	Simulation results	77
F.3	Interpretation of results.....	79
Annex G: Simulation results for CPCH.....		80
G.1	Simulation Assumptions	80
G.2	CPCH Channel Selection Algorithms	81
G.2.1	Simple CPCH channel selection algorithm	81

G.2.2	The recency table method.....	81
G.2.3	The idle-random method.....	81
G.3	Simulation Results.....	81
G.3.1	Cases A-B: Comparison of idle-random method and the recency method for 30 ms packet inter-arrival time, 480 bytes, and 6 CPCH channels, each @ 384 ksps	81
G.3.2	Case C-D-E: Comparison of the three methods for multiple CPCH.....	82
G.3.3	Cases E-F: Impact of packet inter-arrival time	84
G.3.4	Case G: Number of mobiles in a cell	85
G.3.5	Case H-I: Comparison of recency and idle-random methods for single CPCH	85
G.3.6	Case H and J: Comparison of single CPCH and multiple CPCH, idle-random at 2 Msps.....	86
G.4	Discussion on idle-AICH and use of TFCI	86
G.5	Recommended RRM Strategies	86
Annex H: Examples of RACH/PRACH Configuration		87
H.1	Principles of RACH/PRA CH Configuration	87
Annex I: Example of PCPCH assignment with VCAM.....		89
Annex J: Examples of scheduling functions for HSDPA.....		91
J.1	Link adaptation	91
J.2	Priority scheduling functions.....	91
Annex K: Change history.....		95

Foreword

This Technical Report (TR) has been produced by the 3rd Generation Partnership Project (3GPP).

The contents of the present document are subject to continuing work within the TSG and may change following formal TSG approval. Should the TSG modify the contents of the present document, it will be re-released by the TSG with an identifying change of release date and an increase in version number as follows:

Version x.y.z

where:

- x the first digit:
 - 1 presented to TSG for information;
 - 2 presented to TSG for approval;
 - 3 or greater indicates TSG approved document under change control.
- y the second digit is incremented for all changes of substance, i.e. technical enhancements, corrections, updates, etc.
- z the third digit is incremented when editorial only changes have been incorporated in the document.

1 Scope

The present document shall describe RRM strategies supported by UTRAN specifications and typical algorithms.

This report is a release independent report. This means that the latest release applicable to 3GPP is the reference that this TR is defined upon, and contains information on all previous releases. Actual release where a given example applies is indicated in the relevant section.

2 References

The following documents contain provisions which, through reference in this text, constitute provisions of the present document.

- References are either specific (identified by date of publication, edition number, version number, etc.) or non-specific.
- For a specific reference, subsequent revisions do not apply.
- For a non-specific reference, the latest version applies. In the case of a reference to a 3GPP document (including a GSM document), a non-specific reference implicitly refers to the latest version of that document *in the same Release as the present document*.

- [1] 3GPP Homepage: www.3gpp.org.
- [2] 3GPP TS 25.212: "Multiplexing and channel coding".
- [3] 3GPP TS 25.215: "Physical layer – Measurements (FDD)".
- [4] 3GPP TS 25.301: "Radio Interface Protocol Architecture".
- [5] 3GPP TS 25.302: "Services provided by the Physical Layer".
- [6] 3GPP TS 25.303: "Interlayer Procedures in Connected Mode".
- [7] 3GPP TS 25.304: "UE procedures in Idle Mode and Procedures for Cell Reselection in Connected Mode".
- [8] 3GPP TS 25.322: "RLC Protocol Specification".
- [9] 3GPP TS 25.331: "Radio Resource Control (RRC); protocol specification".
- [10] 3GPP TS 25.921: "Guidelines and Principles for protocol description and error handling".
- [11] 3GPP TR 21.905: "Vocabulary for 3GPP Specifications".
- [12] 3GPP TS 26.010: "Mandatory Speech Codec speech processing functions AMR Speech Codec General Description".
- [13] 3GPP TS 23.122: "Non-Access-Stratum functions related to Mobile Station (MS) in idle mode".
- [14] 3GPP TS 33.102: "3G Security; Security Architecture".
- [15] 3GPP TS 25.123: "Requirements for support of radio resource management (TDD)".
- [16] 3GPP TS 25.133: "Requirements for support of radio resource management (FDD)".
- [17] 3GPP TS 25.224: "Physical Layer Procedures (TDD)".
- [18] 3GPP TS 25.321: "MAC protocol specification".
- [19] 3GPP TS 22.011: "Service accessibility".
- [20] 3GPP TS 24.008: "Mobile radio interface layer 3 specification – Core Network Protocols".

- [21] 3GPP TS 25.225: "Physical layer – Measurements (TDD)".
- [22] 3GPP TS 25.213: "Spreading and modulation (FDD)".
- [23] 3GPP TS 25.415: " UTRAN Iu interface user plane protocols".
- [24] 3GPP TS 23.107: "Quality of Service (QoS) concept and architecture".
- [25] 3GPP TS 43.129: "Packet Switched Handover for GERAN A/Gb mode, Stage 2".
- [26] 3GPP TR 25.848: "Physical Layer Aspects of UTRA High Speed Downlink Packet Access".
- [27] 3GPP TS 25.433: "UTRAN Iub interface Node B Application Part (NBAP) signalling".
- [28] 3GPP TS 23.060: " General Packet Radio Service (GPRS); Service description; Stage 2".
- [29] 3GPP TS 43.055: "Dual Transfer Mode (DTM), Stage 2".
- [30] 3GPP TS 23.246: "Multimedia Broadcast Multicast Service; Architecture and Functional Description".
- [31] 3GPP TS 25.346: "Introduction of the Multimedia Broadcast/Multicast Service (MBMS) in the Radio Access Network (RAN); Stage 2".
- [32] 3GPP TR 25.803: " S-CCPCH performance for MBMS".
- [33] 3GPP TS 43.318: " Generic access to the A/Gb interface; Stage 2".
- [34] 3GPP TS 44.318: "Generic access to the A/Gb interface; Mobile GA interface layer 3 specification".

3 Definitions and abbreviations

3.1 Definitions

For the purposes of the present document, the terms and definitions given in [9] apply.

3.2 Abbreviations

For the purposes of the present document, the following abbreviations apply:

AC	Access Class of UE
AMC	Adaptive Modulation and Coding
AS	Access Stratum
ARQ	Automatic Repeat Request
BCCH	Broadcast Control Channel
BCH	Broadcast Channel
C-	Control-
CC	Call Control
CCCH	Common Control Channel
CCH	Control Channel
CCTrCH	Coded Composite Transport Channel
CN	Core Network
CRC	Cyclic Redundancy Check
DC	Dedicated Control (SAP)
DCA	Dynamic Channel Allocation
DCCH	Dedicated Control Channel
DCH	Dedicated Channel
DL	Downlink
DRNC	Drift Radio Network Controller
DSCH	Downlink Shared Channel

DTCH	Dedicated Traffic Channel
DTM	Dual Transfer Mode
EDGE	Enhanced Data Rate for GSM Evolution
FACH	Forward Link Access Channel
FCS	Frame Check Sequence
FDD	Frequency Division Duplex
FEC	Feed-forward Error Correction
GAN	Generic Access Network
GANC	Generic Access Network Controller
GC	General Control (SAP)
GERAN	GSM/EDGE Radio Access Network
GSM	Global System for Mobile Communications
HARQ	Hybrid Automated ReQuest
HCS	Hierarchical Cell Structure
HO	Handover
HSDPA	High Speed Downlink Packet Access
ITU	International Telecommunication Union
kbps	kilo-bits per second
L1	Layer 1 (physical layer)
L2	Layer 2 (data link layer)
L3	Layer 3 (network layer)
LAI	Location Area Identity
MAC	Medium Access Control
MBMS	Multimedia Broadcast Multicast Service
MCCH	MBMS point-to-multipoint Control Channel
MTCH	MBMS point-to-multipoint Traffic Channel
MCS	Modulation & Coding scheme
MM	Mobility Management
NAS	Non-Access Stratum
Nt	Notification (SAP)
PCCH	Paging Control Channel
PCH	Paging Channel
PDU	Protocol Data Unit
PHY	Physical layer
PhyCH	Physical Channels
PLMN	Public Land Mobile Network
p-t-p	point-to-point
p-t-m	point-to-multipoint
RAB	Radio Access Bearer
RACH	Random Access Channel
RAT	Radio Access Technology
RLC	Radio Link Control
RNC	Radio Network Controller
RNS	Radio Network Subsystem
RNTI	Radio Network Temporary Identity
RRC	Radio Resource Control
SAP	Service Access Point
SCCH	Synchronisation Control Channel
SCH	Synchronisation Channel
SDU	Service Data Unit
SIR	Signal-to-Interference power Ratio
SRNC	Serving Radio Network Controller
SRNS	Serving Radio Network Subsystem
TCH	Traffic Channel
TDD	Time Division Duplex
TFCI	Transport Format Combination Indicator
TFI	Transport Format Indicator
TMSI	Temporary Mobile Subscriber Identity
TPC	Transmit Power Control
U-	User-
UE	User Equipment
UL	Uplink

UMTS	Universal Mobile Telecommunications System
URA	UTRAN Registration Area
UTRA	UMTS Terrestrial Radio Access
UTRAN	UMTS Terrestrial Radio Access Network

4 Idle Mode Tasks

4.1 Overview

When a UE is switched on, a public land mobile network (PLMN) is selected by the Non-Access Stratum (NAS) and indicated to the Access Stratum (AS). The PLMN selection process is specified in [13]. The AS then searches for a suitable cell of the selected PLMN (the PLMN indicated from NAS to AS) to camp on.

A PLMN may rely on several radio access technologies (RATs), e.g. UTRAN and GSM/GERAN/GAN. The NAS can control the RATs in which the cell selection should be performed, for instance by indicating RATs associated with the selected PLMN [13]. The UE shall select a suitable cell of the selected PLMN based on the radio access technology indication from NAS and based on idle mode measurements and the cell selection criteria as defined in [7].

After successful cell selection the UE will then register its presence, by means of a NAS registration procedure, in the registration area of the chosen cell, if necessary [20].

When camped on a cell, the UE shall regularly search for a better cell according to the cell re-selection criteria. If a better cell is found, that cell is selected by the UE. Cell selection and re-selection procedures for the UE in idle and RRC connected mode are defined in [7].

Different types of measurements are used in different RATs (UTRA, GSM/GERAN/GAN) and modes (UTRA FDD/TDD) for the cell selection and re-selection. The performance requirements for the measurements are specified in [15][16].

The description of cell selection and re-selection reported below applies to a UE supporting at least UTRA technology. Cell selection and re-selection procedures of other RATs are defined in the appropriate specification of that RAT (e.g. [1]).

The GAN capable terminals introduced in release 6 may support any IP access technology in addition to the GERAN and UTRAN radio interfaces. The UE/MS may be either in the GERAN/UTRAN mode or in GAN mode of operation defined in [33] and [34].

4.2 Service type in Idle mode

Services are distinguished into categories defined in [7]; also the categorisation of cells according to services they can offer is provided in [7].

- **Normal Service.** A UE camped on a suitable cell can obtain normal service from the selected PLMN. Normal service always requires registration to the PLMN [20].
- **Limited Service.** In case the UE could not find any suitable cell of the selected PLMN, it camps on an acceptable cell, where it could only obtain limited services (e.g. emergency calls) from the network. If registered to a PLMN, the UE shall continuously attempt to find a suitable cell of the selected PLMN, trying all frequency bands and RATs it is capable of. While being in limited service state and camped on an acceptable cell, the UE follows normal cell re-selection procedures (e.g. continuously performs the “cell reselection evaluation process” as defined in [7]).
- **Operator Service.** In case the UE contains a SIM/USIM with an Access Class (AC) 11 and/or 15 and it is in its HomePLMN, the UE is allowed to select or re-select cells which are indicated as “reserved for operator use” in the system information. Such UEs shall treat those cells as normal cells during the cell selection and re-selection process, hence not exclude the cells from cell selection or re-selection. Operator Service is only applicable to UEs with AC 11 and/or 15 while in the HomePLMN. Other UEs shall treat such cells as barred.

In the following, some typical examples of the use of the different types of cell status are provided:

- **Cell barred.** In some cases (e.g. due to traffic load or maintenance reasons) it may be necessary to temporarily prevent any access in a cell. A UE shall not camp on a barred cell, not even for limited services. If a cell on which a UE is camped becomes barred, it becomes unsuitable and a cell reselection is triggered.
- **Cell reserved for operator use.** The aim of this type of cell is to allow the operator using and test newly deployed cells without being disturbed by normal traffic. For normal users (indicated by SIM/USIM assigned to an AC in the range 0 to 9) and special non-operator users (indicated by SIM/USIM assigned to AC in the range 12 to 14), the UE shall behave as if the cell is barred. UEs containing a SIM/USIM with AC 11 and/or 15 are allowed to reselect those cells while in Home PLMN using normal cell selection and re-selection procedures.
- **Cell reserved for future extension.** All UEs without exceptions shall treat a cell which status is indicated as "reserved for future extension" as barred.

The cell status is indicated in the system information [9] and the full requirements on the UE behaviour are defined in [7]. Details on the access class concept, which is re-used to provide UEs which special rights (e.g. configure normal UEs as "operator UEs") can be found in [19]. Impacts of reserved cells on the cell re-selection procedure are captured in the following section.

4.3 Criteria for Cell Selection and Reselection

Cell selection and re-selection processes are the same for UE in idle and RRC connected mode as defined in [7].

4.3.1 Cell Selection

The goal of the cell selection process is to find a suitable cell to camp on quickly. To speed up this process, when switched on or when returning from "out of coverage", the UE shall start with stored information from previous network contacts. If the UE is unable to find any suitable cell among those cells for which information was stored, the initial cell search procedure shall be initiated.

The UE shall measure CPICH Ec/No and CPICH RSCP for FDD cells and P-CCPCH RSCP for TDD cells to evaluate the cell selection criteria [7]. A cell is suitable if it fulfils the cell selection criterion S specified in [7].

If it is not possible after a complete scan of all frequencies on all RATs supported by the UE to find a suitable cell of the selected PLMN, the UE shall camp on an acceptable cell of the selected PLMN and enter "limited service state". If the UE does not succeed to find any suitable or acceptable cell of the selected PLMN, the UE will choose a cell in a different PLMN including forbidden PLMNs (e.g. if in the home country), enters "limited service state" and gives an indication to NAS. In this state the UE regularly attempt to find a suitable cell of the selected PLMN, while camping on an acceptable cell if no other PLMN has been selected by NAS. If a better cell is found during the cell re-selection evaluation process, the UE reselects to that cell and has to read the system information of that cell to perform cell reselection evaluation process based on parameters sent on that cell.

In order to define a minimum quality level for camping on the cell, a quality threshold different for each cell can be used. The quality threshold for cell selection is indicated in the system information.

4.3.2 Cell Re-selection

The goal of the cell re-selection process is to always camp on a cell which provides best quality for accessing the network. When camped normally or camped on any cell, the UE shall monitor relevant System Information and perform necessary measurements for the cell re-selection evaluation process as defined in [7].

The cell re-selection evaluation process, i.e. the process to find whether a better cell exist, is performed on a UE internal trigger [15][16] or when the system information relevant for cell re-selection are changed. Performance requirements for the cell re-selection are also defined in [15][16].

4.3.2.1 Hierarchical Cell Structures

The radio access network may be designed using hierarchical cell structures. An example of hierarchical cell structure (HCS) is shown below. Numbers in the picture describe different layers in the hierarchy. The highest hierarchical layer,

i.e. typically smallest cell size, has the higher priority (number 3 in the figure). The HCS priority of each cell is given in system information [9].

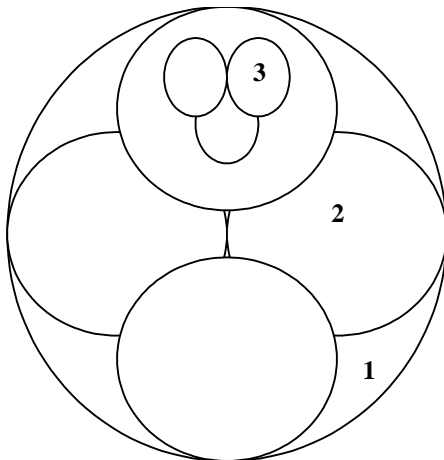

Figure 4-1: Example of Hierarchical Cell Structure

Normally, different layers are created using different frequencies. However, in some scenarios, different layers can use the same frequency. Different frequencies can also be used on the same hierarchical layer e.g. in order to cope with high load in the system.

The operator can control the transitions between two layers or between any two cells, regardless of whether the two cells have equal or different priority. The control is performed both in terms of measurements on target cells and in terms of parameter settings in order to achieve hysteresis and cell border offset effects.

In order to cope with UEs travelling fast through smaller cells (e.g. through micro or pico cells), the cell reselection procedure can be performed towards bigger cells on lower priority layers e.g. to macro cells so as to avoid unnecessary cell reselections. The cell re-selection procedures when using HCS are defined in [7].

4.3.2.2 Measurements for cell re-selection

The quality measurements to be performed on the cell candidates for cell re-selection are controlled by the UTRAN. According to the quality level of the serving cell and the threshold indicated in the system information, the UE measurements are triggered fulfilling different requirements for intra-frequency, inter-frequency or inter-RAT quality estimation.

When HCS is used, it is also possible to further restrict the range of the measured cells, considering only the cells at higher priority level HCS_PRIO. Moreover the UE speed may be taken into account. When a the number of reselections during a time period T_{CRmax} exceeds the value N_{CR} given in the system information, the UE is considered in high-mobility state. In this case the measurements are performed on the cells that have equal or lower HCS_PRIO than the serving cell. If the number of reselection during T_{CRmax} no longer exceeds N_{CR} , the UE leaves the high-mobility state after a time period $T_{CRmaxHyst}$. Parameters for measurement control are indicated in the system information [9].

4.3.2.3 Cell re-selection criteria

The cells on which the UE has performed the measurement and that fulfil the S criterion specified for cell selection are candidates for cell re-selection.

These cells are ranked according to the criterion R [7]. The quality of the target cells is evaluated and compared with the serving cell by mean of relative offsets.

The parameter "cell selection and re-selection quality measure", sent on system information, controls the ranking of UTRA FDD cell using CPICH RSCP only or CPICH Ec/No additionally.

When the serving cell belongs to a HCS (i.e. HCS is indicated in the system information), a temporary offset applies for a given penalty time to the cells on the same priority level as the serving cell.

When HCS is used, an additional criterion H is used to identify target cells on a different layer. During the quality estimation of those cells, a temporary offset applies for a given penalty time. If the quality requirement H is fulfilled, the cells belonging to the higher priority level are included for cell re-selection and ranked according to the criterion R. However, if the UE is in the high-mobility state, this rule does not apply and the ranking is performed on the candidate cells according to the measurements performed.

The cell with higher value R in the ranking list is chosen as new cell if all the criteria described above are fulfilled during a time interval $T_{reselection}$.

All the counters, timers, offsets and thresholds used to control the cell re-selection evaluation process are indicated in the system information [9]. These parameters are unique on a cell-to-neighbour-cell relation basis. This implies that the UE does not need to read the system information in the neighbouring cells before the cell re-selection procedure finds a neighbouring cell with better quality.

4.3.3 Mapping of thresholds in cell reselection rules

When HCS is used, mapping of signalled values for the thresholds Q_{hcs} shall be used. Different mapping is applied for CPICH E_c/N_0 and CPICH RSCP for FDD cells, P-CCPCH RSCP for TDD cells, and RSSI for GSM cells. The explicit mapping is indicated in system information [9].

4.3.4 Barred / Reserved Cells and Access Restrictions for Cells

4.3.4.1 Barred cells

When cell status "barred" is indicated [9] no UE is permitted to select/re-select this cell, not even for limited services. If a suitable cell becomes barred while a UE camps on that cell, it becomes unsuitable and UE triggers a cell re-selection to another suitable cell.

4.3.4.2 Reserved cells

When the cell status "reserved for operator use" is indicated [9] and the access class of the UE is 11 and/or 15 [19], the UE may select/re-select this cell if in HomePLMN by treating the cell as a normal candidate for cell selection or re-selection. In all other cases UEs treat such a cell as barred and behave as for barred cells.

When the cell status "reserved for future extension" is indicated [9] all UEs shall treat such a cell as barred and behave as for barred cells.

In all these cases, the criteria for selection of another cell should take into account the effects of the interference generated towards the barred or reserved cell. For this reason, the cell re-selection of any cell on the same frequency as the barred or reserved cell is prohibited if the "Intra-frequency cell re-selection indicator" is set to "not allowed". If no suitable cell is found on either a different UTRA frequency or RAT, the UE enters a limited service state and remains on the original UTRAN frequency. In this state, in order to detect a change of the reservation status, the UE shall perform a periodic check every T_{barred} seconds. When the neighbour cells use only the same frequency, the only way to provide the service on UTRA in the area is to allow the UE to camp on another cell on the same frequency, regardless of the interference generated on the reserved cell. This is done by setting the "Intra-frequency cell re-selection indicator" IE to "allowed".

When the UE still detect the barred or reserved cell as the "best" one, it reads the system information and evaluates again the availability of that cell. The unnecessary evaluation may be avoided excluding the restricted cell from the neighbouring cell list for a time interval of T_{barred} seconds.

"Intra-frequency cell re-selection indicator" and " T_{barred} " are indicated together with the cell barred or reserved status in the system information [9].

4.3.4.3 Access Restrictions for Cells

Due to load reasons it might be necessary for UTRAN to disallow access to cells temporarily. For this reason the Access Class Barring concept was introduced [9] [19]. The access restrictions for a cell are indicated on system information. By barring a certain access class or a number of access classes, UTRAN can prevent a certain amount of UE from accessing the cell. The concept of access class barring is only applicable to prevent access from UEs which are in idle mode. If the UEs AC is indicated as barred in the cell the UE camps on, the UE shall not reselect to a

neighbouring cell, but remain camped on the original cell, which is still suitable. The UE has to check the Access Class barred status of a cell prior to every access attempt from idle mode.

A restriction on emergency calls, if needed, can be indicated in the "Access class barred list" IE [4]. If AC 10 is indicated as barred in a cell, UEs with AC 0 to 9 or without an IMSI are not allowed to initiate emergency calls in this cell. For UEs with AC 11 to 15, emergency calls are not allowed if both AC 10 and the relevant AC (11 to 15) are barred. Otherwise, emergency calls are allowed for those UEs [7].

4.4 Location Registration

The location registration procedure is defined in [13]. The strategy used for the update of the location registration has to be set by the operator and, for instance, can be done regularly and when entering a new registration area.

5 RRC Connection Mobility

5.1 Handover

5.1.1 Strategy

The handover strategy employed by the network for radio link control determines the handover decision that will be made based on the measurement results reported primarily by the UE but also by measurements in the network or various parameters set for each cell. Network directed handover might also occur for reasons other than radio conditions, e.g. to control traffic distribution between cells. The network operator will determine the exact handover strategies. Possible types of Handover are as follows:

- FDD soft/softer handover;
- FDD or TDD intra/inter-frequency hard handover;
- FDD to TDD Handover;
- TDD to FDD Handover;
- Inter-RAT Handover (e.g. Handover to GERAN *A/Gb mode* or to GERAN *Iu mode*);
- Inter-RAT Handover (e.g. Handover from GERAN *A/Gb mode* or from GERAN *Iu mode*).

5.1.2 Causes

The following is a non-exhaustive list for causes that could be used for the initiation of a handover process.

- Uplink quality (e.g. BER);
- Uplink signal measurements (e.g. RSCP for TDD);
- Downlink quality (e.g. Transport channel BLER);
- Downlink signal measurements (e.g. CPICH RCSP, CPICH E_c/N_0 , Pathloss);
- Distance;
- Change of service;
- O&M intervention;
- Directed retry;
- Traffic load;
- Pre-emption.

5.1.3 Hard Handover

The hard handover procedure is described in [9] and example message sequences could be found in [6].

Two main strategies can be used in order to determine the need for a hard handover:

- received measurements reports;
- load control.

5.1.4 Soft Handover

5.1.4.1 Soft Handover Parameters and Definitions

Soft Handover is a handover in which the mobile station adds and removes radio links in such a manner that the UE always keeps at least one radio link to UTRAN. This can be performed on the same carrier frequency only. For this reason Soft Handover allows easily the provision of macrodiversity transmission; for this intrinsic characteristic terminology tends to identify Soft Handover with macrodiversity even if they are two different concepts; for its nature soft handover is used in CDMA systems where the same frequency is assigned to adjacent cells. As a result of this definition there are areas of the UE operation in which the UE is simultaneously communicating via a number of radio links towards different cells. With reference to Soft Handover, the "Active Set" is defined as the set of radio links simultaneously involved in the communication between the UE and UTRAN (i.e., the UTRA cells currently assigning a downlink DPCH to the UE constitute the active set).

The Soft Handover procedure is composed of a number of single functions:

- Measurements;
- Filtering of Measurements;
- Reporting of Measurement results;
- The Soft Handover Algorithm;
- Execution of Handover.

Cell measurements are filtered in the UE according to [5] and based on the measurement reporting criteria a report is sent to UTRAN. This report constitute the basic input to the Soft Handover Algorithm. There are two types of measurement reporting criteria that could be used, event triggered or periodical.

The definition of 'Active Set', 'Monitored set', as well as the description of all reporting is given in [9].

Based on the cell measurements, the Soft Handover function evaluates if any cell should be added to (Radio Link Addition), removed from (Radio Link Removal), or replaced in (Combined Radio Link Addition and Removal) the Active Set; performing than what is known as "Active Set Update" procedure.

5.1.4.2 Example of a Soft Handover Algorithm

A describing example of a Soft Handover Algorithm presented in this subclause which exploits reporting events 1A, 1B, and 1C described in [9] It also exploits the Hysteresis mechanism and the Time to Trigger mechanism described in [9]. Any of the measurements quantities listed in [9] can be considered.

Other algorithms can be envisaged that use other reporting events described in [9]; also load control strategies can be considered for the active set update, since the soft handover algorithm is performed in the RNC.

For the description of the Soft Handover algorithm presented in this subclause the following parameters are needed:

- AS_Th: Threshold for macro diversity (reporting range);
- AS_Th_Hyst: Hysteresis for the above threshold;
- AS_Rep_Hyst: Replacement Hysteresis;
- ΔT : Time to Trigger;

- AS_Max_Size: Maximum size of Active Set.

The following figure describes this Soft Handover Algorithm.

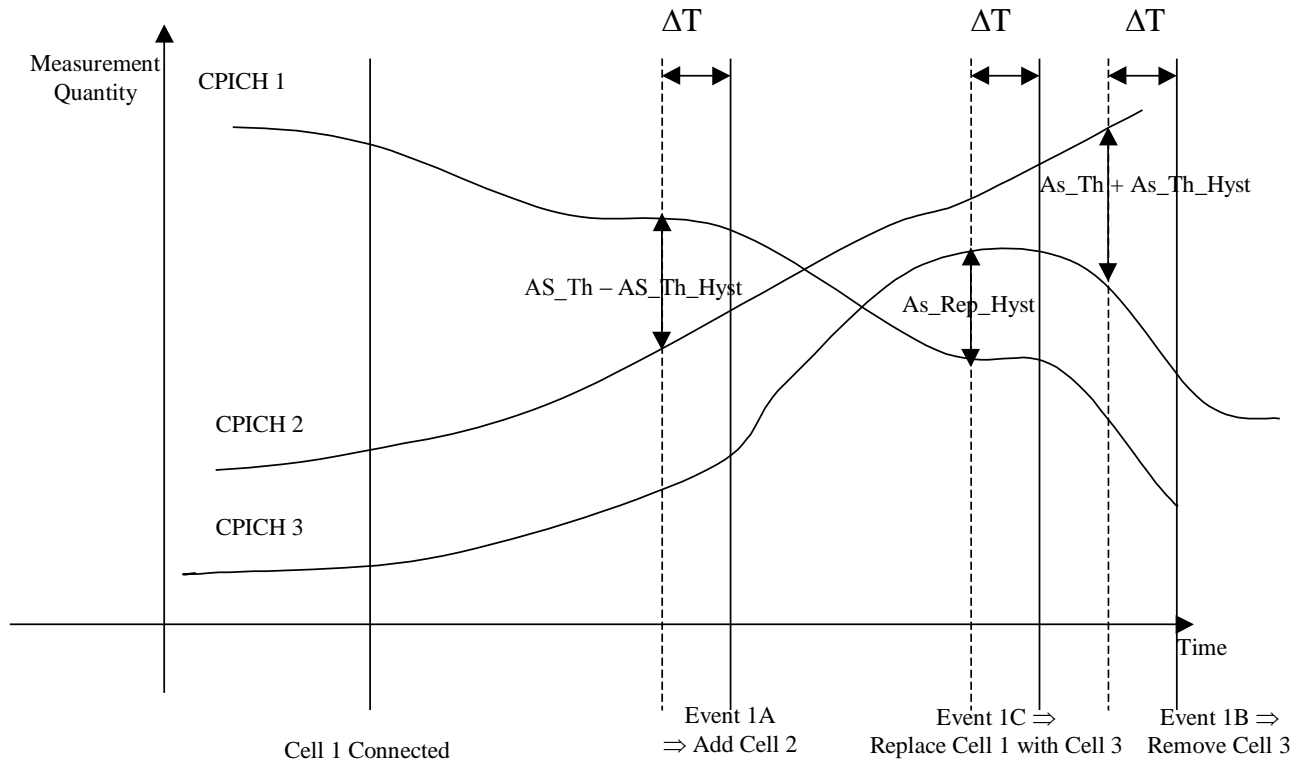

Figure 5-1: Example of Soft Handover Algorithm

As described in the figure above:

- If Meas_Sign is below $(Best_Ss - As_Th - As_Th_Hyst)$ for a period of ΔT remove Worst cell in the Active Set.
- If Meas_Sign is greater than $(Best_Ss - As_Th + As_Th_Hyst)$ for a period of ΔT and the Active Set is not full add Best cell outside the Active Set in the Active Set.
- If Active Set is full and Best_Cand_Ss is greater than $(Worst_Old_Ss + As_Rep_Hyst)$ for a period of ΔT add Best cell outside Active Set and Remove Worst cell in the Active Set.

Where:

- Best_Ss :the best measured cell present in the Active Set;
- Worst_Old_Ss: the worst measured cell present in the Active Set;
- Best_Cand_Set: the best measured cell present in the monitored set.
- Meas_Sign :the measured and filtered quantity.

A flow-chart of the above described Soft Handover algorithm is available in Appendix C.

5.1.4.3 Soft Handover Execution

The Soft Handover is executed by using the active set update procedure described in [9]. There are three main scenarios as listed below, and these could also be found in [6]:

- Radio Link Addition;
- Radio Link Removal;

- Combined Radio Link Addition and Removal.

The serving cell(s) (the cells in the active set) are expected to have knowledge of the service used by the UE. The Node-B with the new cell decided to be added to the active set shall be informed that a new connection is desired, and the following minimum information need to be forwarded from the RNC to the Node-B:

- Connection parameters, such as coding schemes, number of parallel code channels, scrambling codes etc. parameters which form the set of parameters describing the different transport channel configurations in use both uplink and downlink.
- The relative timing information of the new cell, in respect to the timing UE is experiencing from the existing connections (as measured by the UE at its location). Based on this, the new Node-B can determine what should be the timing of the transmission initiated in respect to the timing of the common channels (CPICH) of the new cell.

On the existing connection the RNC need to inform the UE the following:

- What channelisation code(s) are used for that transmission. The channelisation codes from different cells are not required to be the same as they are under different scrambling codes.
- The relative timing information, which needs to be made available at the new cell is indicated in Figure 5-1 (shows the case where the two involved cells are managed by different Node-Bs).

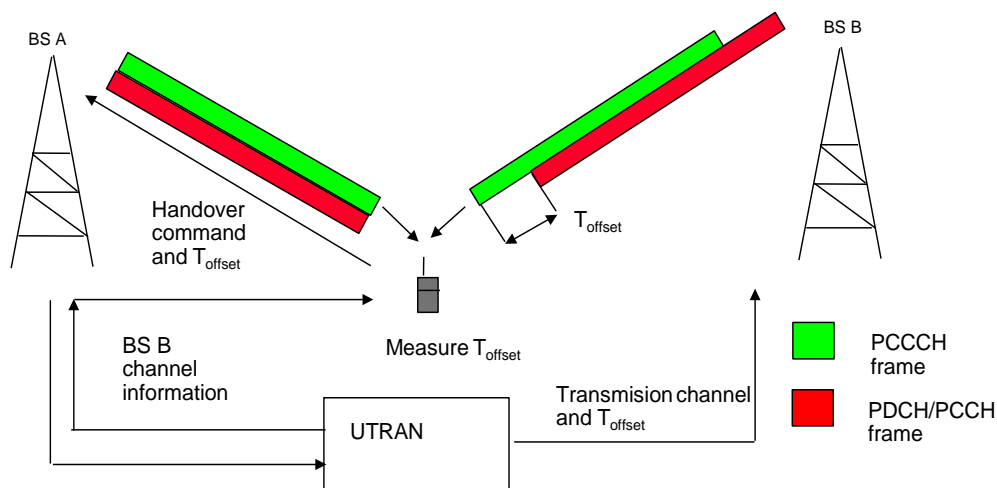

Figure 5-2: Making transmissions capable to be combined in the Rake receiver from timing point of view

At the start of diversity handover, the uplink dedicated physical channel transmitted by the UE, and the downlink dedicated physical channel transmitted by the Node-B will have their radio frame number and scrambling code phase counted up continuously, and they will not be affected by the soft handover. User data carried on both uplink and downlink will continue without any interruption.

5.1.5 Inter Radio Access Technology Handover

5.1.5.0 General

This sub-clause describes the inter RAT handovers between GSM and UTRAN for the following scenarios:

- CS handover between GERAN *A/Gb mode* and UTRAN
- PS handover between GERAN *A/Gb mode* and UTRAN
- CS handover between GERAN *Iu mode* and UTRAN
- PS handover between GERAN *Iu mode* and UTRAN (Rel-6)

- CS handover between GAN *mode* and UTRAN (Rel-6)
- DTM handover between GERAN *A/Gb mode* and UTRAN (Rel-7)
- PS handover between GAN *mode* and UTRAN (Rel-7).

5.1.5.1 Handover UTRAN to GSM

In order for the UE to perform handover from UTRA FDD mode to GSM without simultaneous use of two receiver chains, a UE can perform measurements by using idle periods in the downlink transmission, where such idle periods are created by using the downlink compressed mode as defined in [2]. The compressed mode is under the control of the UTRAN and the UTRAN signals appropriate configurations of compressed mode pattern to the UE. For some measurements also uplink compressed mode is needed, depending on UE capabilities and measurement objects.

Alternatively independent measurements not relying on the compressed mode, but using a dual receiver approach can be performed, where the GSM receiver branch can operate independently of the UTRA FDD receiver branch.

The handover from UTRA TDD mode to GSM can be implemented without simultaneous use of two receiver chains. A UE can perform the measurements either by efficiently using idle slots or by getting assigned free continuous periods in the downlink by reducing the spreading factor and compressing in time TS occupation in a similar way as for FDD compressed mode.

For smooth inter-operation, inter-system information exchanges are needed in order to allow the UTRAN to notify the UE of the existing GSM frequencies in the area and vice versa. Further more integrated operation is needed for the actual handover.

5.1.5.2 Handover GSM to UTRAN

In the following clauses, first the general concept and requirements are introduced. Next the typical flow of information is described.

5.1.5.2.1 Introduction

The description provided in the following mainly deals with the use of predefined radio configuration during handover from GSM/GERAN to UTRAN. However, the description of the handover information flows also includes details of other RRC information transferred during handover e.g. UE radio capability and security information.

5.1.5.2.2 Predefined radio configuration information

In order to reduce the size of certain size critical messages in UMTS, a network may download/ pre-define one or more radio configurations in a mobile via system information. A predefined radio configuration mainly consists of radio bearer- and transport channel parameters. A network knowing that the UE has suitable predefined configurations stored can then refer to the stored configuration requiring only additional parameters to be transferred.

Predefined configurations may be applied when performing handover from another RAT to UTRAN. In the case of handover from GSM to UTRAN, the performance of handover to UTRAN is improved when it is possible to transfer the handover to UTRAN command within a non-segmented GSM air interface message.

Furthermore, it is important to note that it is a network option whether or not to use pre-configuration; the handover to UTRAN procedures also support transfer of a handover to UTRAN command including all parameters and the use of default configurations.

NOTE: In case segmentation is used, subsequent segments can only be transferred after acknowledgement of earlier transmitted segments. In case of handover however, the quality of the UL may be quite poor resulting in a failure to transfer acknowledgements. This implies that it may be impossible to quickly transfer a segmented handover message. Segmentation over more than two GSM air interface messages will have a significantly detrimental, and unacceptable, impact on handover performance.

The UE shall be able to store upto 16 different predefined configurations, each of which is identified with a separate pre-configuration identity. The UE need not defer accessing the network until it has obtained all predefined configurations. The network may use different configurations for different services e.g. speech, circuit switched data. Moreover, different configurations may be needed because different UTRAN implementations may require service configurations to be customised e.g. different for micro and macro cells.

The predefined configurations stored within the UE are valid within the scope of a PLMN (including equivalent PLMNs); the UE shall consider these configurations to be invalid upon PLMN re-selection (meaning that these configurations shall remain valid when changing between cells of PLMNs that are equivalent). Furthermore, a value tag is associated with each individual predefined configuration. This value tag, that can have 16 values, is used by the UE and the network to ensure the stored predefined configuration(s) is the latest/required version. 5.1.5.2.2a Default configuration information

A default configuration is a set of radio bearer and transport channel parameters for which the values are defined in [9]. While the network can configure the parameter values to be used in a predefined configuration in a flexible manner, the set of radio bearer parameter values for a default configuration are specified and hence fixed. The main advantage of default configurations is that they can be used at any time; they need not be downloaded into the UE via system information.

5.1.5.2.3 Security and UE capability information

The security requirements concerning handover to UTRAN are specified in [14].

The initialisation parameters for ciphering are required to be transferred to the target RNC prior to the actual handover to UTRAN to ensure the immediate start of ciphering.

For UEs involved in only CS domain services or in both CS & PS domain services, the specifications support handover for the CS domain services while the PS domain services are re-established later. Consequently, in these cases only the START for the CS domain service needs to be transferred prior to handover. The START for the PS domain may be transferred at the end of the handover procedure, within the HANDOVER TO UTRAN COMPLETE message.

For UEs involved in only PS domain services, in the cases when the handover of the PS domain services is supported, the START for the PS domain service needs to be transferred prior to handover.

For UEs involved in CS and PS domains services, in the cases when the handovers of the CS and PS domains services are supported in parallel, the START for the CS domain service and the START for the PS domain service need to be transferred prior to handover.

It should be noted that inter RAT handover normally involves a change of ciphering algorithm, in which case the new algorithm is included within the HANDOVER TO UTRAN COMMAND message.

Activation of integrity protection requires additional information transfer e.g. FRESH. Since the size of the HANDOVER TO UTRAN COMMAND message is critical, the required integrity protection information can not be included in this message. Instead, integrity protection is started immediately after handover by means of the security mode control procedure. Therefore, the HANDOVER TO UTRAN COMMAND and the HANDOVER TO UTRAN COMPLETE messages are not integrity protected.

5.1.5.2.4 UE capability information

When selecting the RRC radio configuration parameters to be included in the HANDOVER TO UTRAN COMMAND message, UTRAN should take into account the capabilities of the UE. Therefore, the UE radio capability information should be transferred to the target RNC prior to handover to UTRAN from the source RAT. This means that if a call is started in GSM this information also need to be transferred on the GSM radio interface.

5.1.5.2.5 Handover to UTRAN information flows, typical example

The handover to UTRAN procedure may include several subsequent information flows. The example described in this subclause is representative of a typical sequence of information flows. It should be noted that some procedures may actually be performed in parallel e.g. configuration of UTRA measurements and downloading of predefined configurations.

The description includes the different network nodes and interfaces involved in the handover to UTRAN procedure.

Flow 1: Downloading of predefined configuration information within UTRA

If the UE uses UTRA prior to entering another RAT, it may download predefined configuration information as shown in the following diagram. UTRAN broadcasts predefined configuration information within the system information. The UE should read and store all the configurations broadcast by UTRAN. The configurations should be used when re-entering UTRAN.

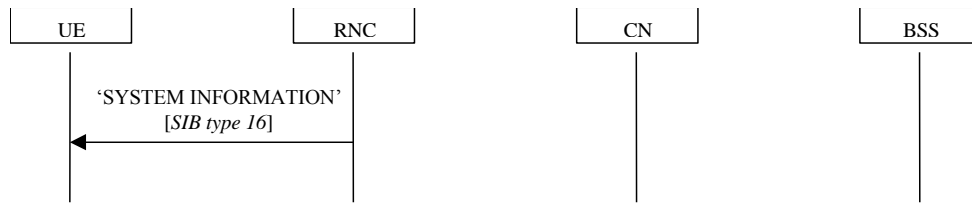

Flow 2: UE capability, security and predefined configuration information exchange

In order to prepare for handover to UTRAN, the BSS may retrieve UE capability, security and predefined configuration status information by means of the sequence shown below. This procedure may not only be invoked upon initial entry of a mobile supporting UTRA within GSM, but also when the mobile continues roaming within the GSM network. It should be noted that, the mobile could also send the information automatically by means of the early classmark sending procedure.

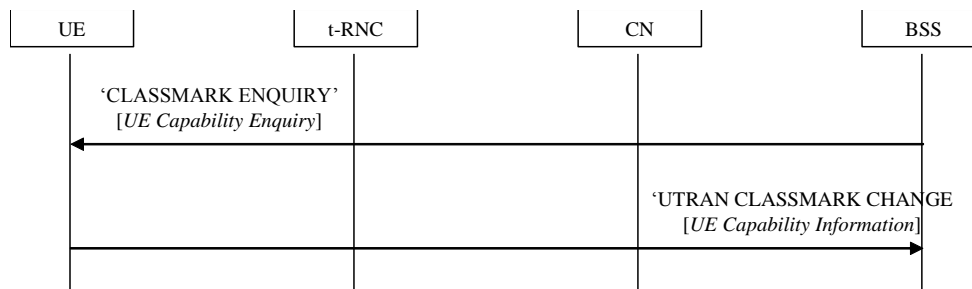

Furthermore, predefined configuration status information may be transferred to the BSS during handover from UTRAN. The BSS has to store the received information until the handover to UTRAN is invoked.

NOTE 1: During the handover procedure, the stored UE capability and security information is sent to the target RNC.

NOTE 2: Depending on the received predefined configuration status information, the BSS may need to invoke alternative procedures for providing configurations, as described in flow 4

Flow 3: Configuration of UTRA measurements

The BSS configures the UTRA measurements to be performed by the mobile, including the concerned thresholds and the reporting parameters, by means of the following information flow.

NOTE: The BSS may possibly decide the measurement configuration to be used based upon previously received UE capability information (e.g. supported modes & bands)

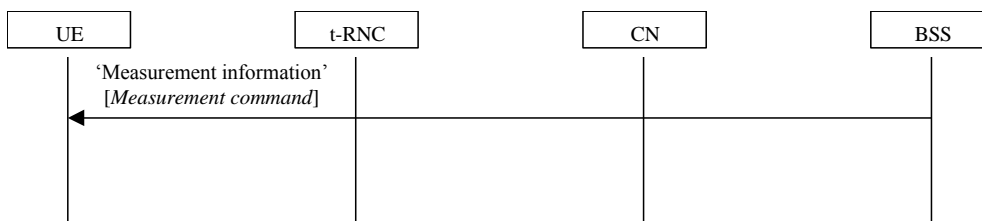

Flow 4: Predefined radio bearer configuration status handling within GSM

The predefined configuration status information (indicating which configurations are stored, as well as their value tags) is included in the UTRAN CLASSMARK CHANGE message. This information may indicate that the UE does not have the required predefined configuration stored, in which case the BSS could use one of the default configurations for the handover to UTRAN procedure or full signalling.

When the BSS decides that handover to UTRAN should be performed, triggered by the reception of a measurement report, it initiates the handover procedure. Next, the CN requests resources by sending a Relocation request to the target RNC. This message should include the UE capability and security information previously obtained by the BSS. The predefined configuration status information should be included in the Relocation request also. The main reason for this

it that when selecting the predefined configuration to be indicated within the handover to UTRAN command message, the target RNC should know if the UE has downloaded all predefined configurations or only a subset.

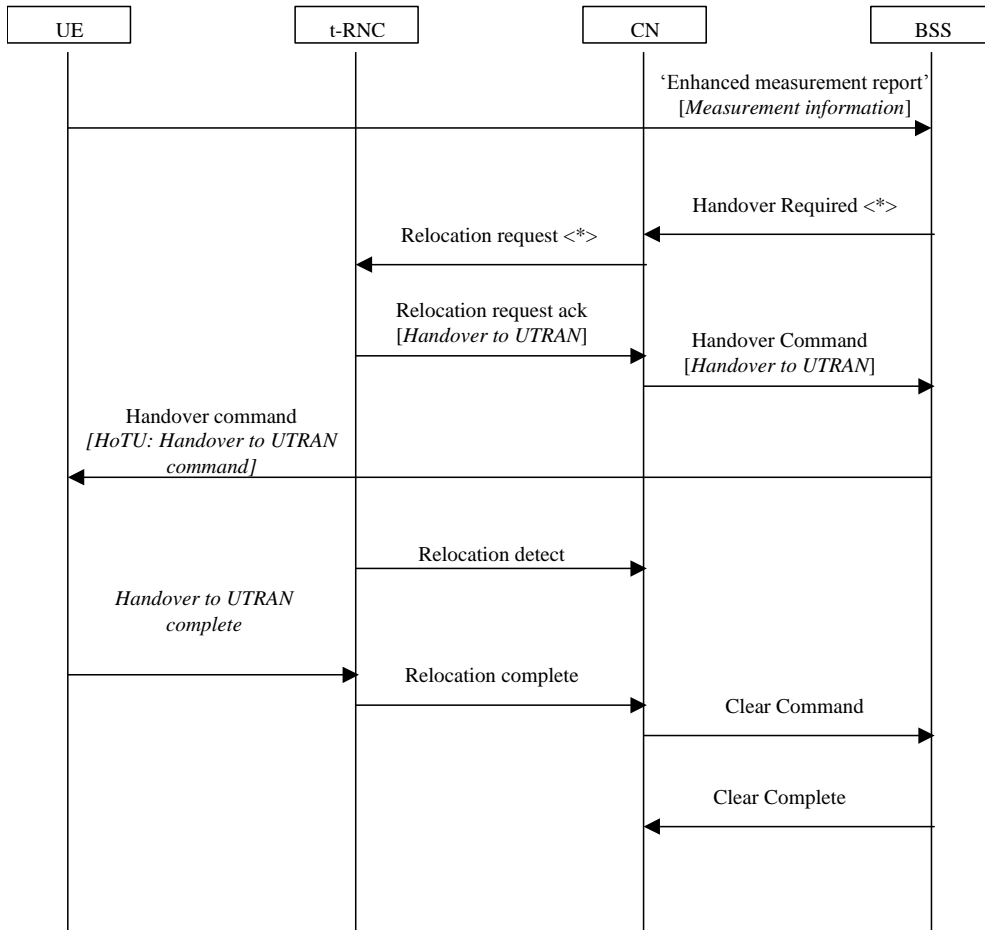

Figure 5.1.5.2.5 –1. Handover of CS domain service to UTRAN

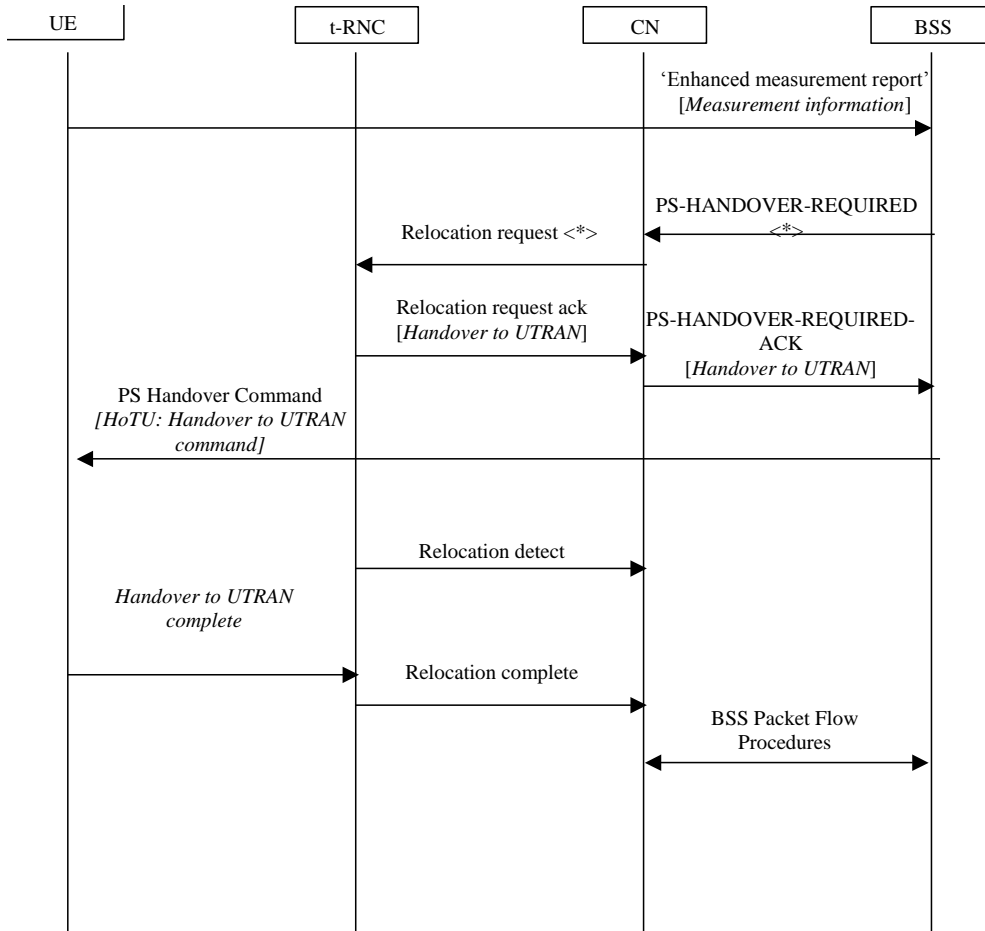

Figure 5.1.5.2.5 – 2 : Handover of PS domain service to UTRAN

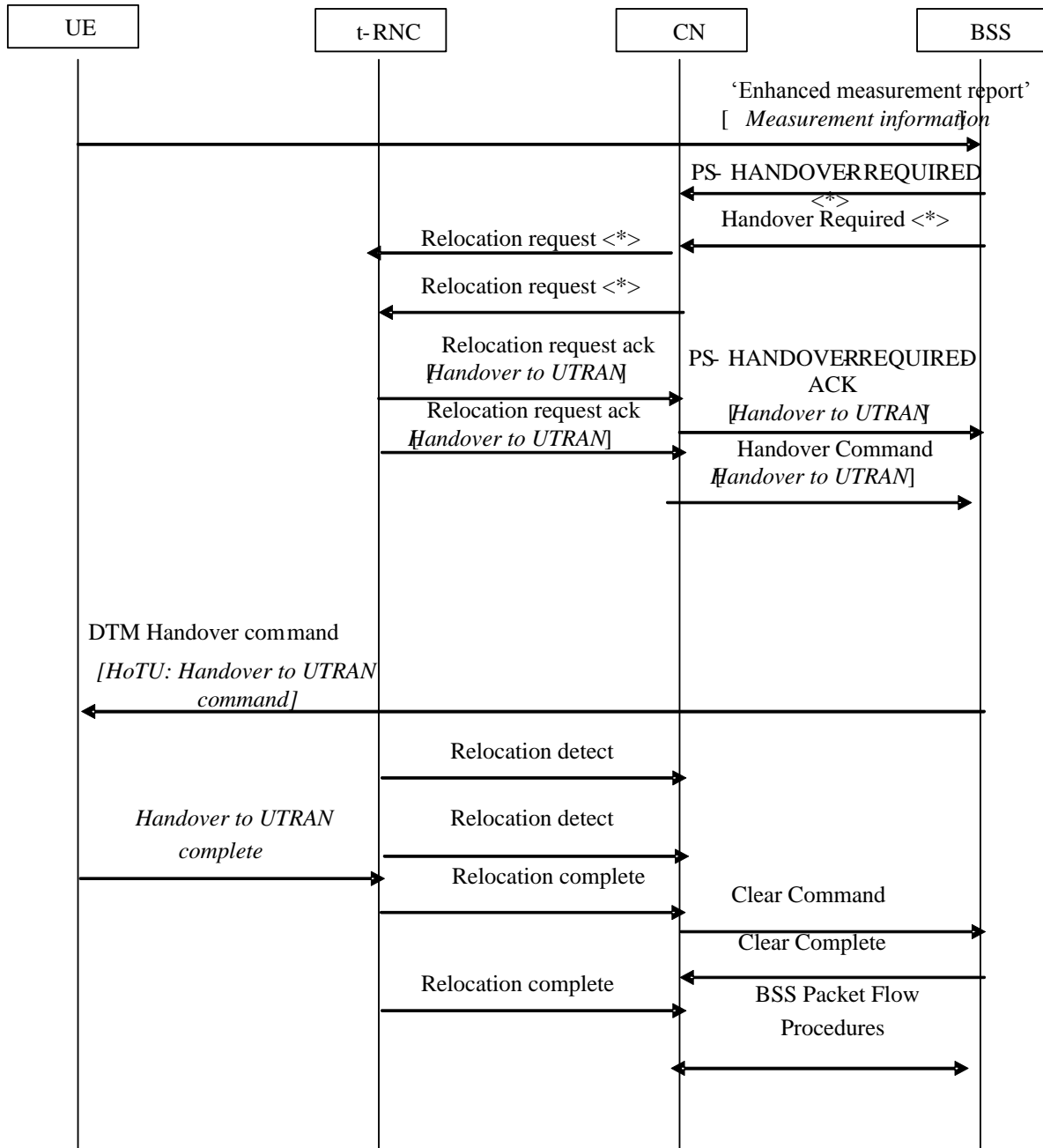

Figure 5.1.5.2.5 – 3 : Inter-RAT DTM Handover to UTRAN from GERAN A/Gb mode

The relocation request includes an indication of the service type for which the handover is requested. This information is used by the target RNC to select the predefined configuration to be used by the UE, which is included within the handover to UTRAN command.

In case no (suitable) predefined configuration is stored within the UE, the network may either completely specify all radio bearer, transport channel and physical channel parameters or use one of the default configurations defined in [9].

For the case where two Iu instances have been indicated in the Handover required message, the source BSS may use either of the Handover to UTRAN Command messages contained in the Relocation request ack messages.

5.1.5.3 Handover from UTRAN to GERAN Iu mode

The existing handover mechanisms defined for UTRAN to GSM handover are reused, see subclauses 5.1.5.1 and 5.1.7.

5.1.5.4 Handover from GERAN Iu mode to UTRAN

The existing handover mechanisms defined for GSM to UTRAN handover are reused, see subclauses 5.1.5.2 and 5.1.7.

5.1.6 Measurements for Handover

5.1.6.1 Monitoring of FDD cells on the same frequency

The UE shall be able to perform intra-frequency measurements simultaneously for data reception from the active set cell/s. If one or several compressed mode pattern sequences are activated, intra frequency measurements can be performed between the transmission gaps. During the measurement process of cells on the same frequencies, the UE shall find the necessary synchronisation to the cells to measure using the primary and secondary synchronisation channels and also the knowledge of the possible scrambling codes in use by the neighbouring cells.

The rules to derive the number of cells, which can be reported by the UE depending on the characteristics of the activated compressed mode patterns, are given in [16].

5.1.6.2 Monitoring cells on different frequencies

5.1.6.2.1 Monitoring of FDD cells on a different frequency

The RNC may ask a FDD UE to perform measurements of inter-frequency cells to perform FDD inter-frequency handover. In such case, UTRAN signals the inter-frequency neighbour cell list and if needed, the compressed mode parameters used to make the needed measurements to the UE. Setting of the compressed mode parameters are defined in [3] and explanation of parameter settings for compressed mode could be seen in the subclause below. Measurements to be performed by the physical layer are defined in [3].

5.1.6.2.1.1 Setting of parameters for transmission gap pattern sequence with purpose "FDD measurements"

During the transmission gaps, the UE shall perform measurements and be able to report to UTRAN the frame timing, the scrambling code and the CPICH E_c/N_0 of FDD cells in the neighbour cell list.

The time needed by the UE to perform the required inter-frequency measurements according to what has been requested by the UTRAN depends on the transmission gap pattern sequence characteristics such as e.g. TGD, TGPL and TGPRC. The rules to derive these measurement times are given in [16].

5.1.6.2.2 Monitoring of TDD cells

The RNC may ask a dual mode FDD/TDD UE to perform measurements of inter-frequency cells to perform handover from FDD to TDD. In such case, UTRAN signals the inter-frequency neighbour cell list, and if needed, the compressed mode parameters used to make the measurements, to the UE. Setting of the compressed mode parameters are defined in [3] and explanation of parameter settings for compressed mode could be seen in the two subclauses below. Measurements to be performed by the physical layer are defined in [21].

5.1.6.2.2.1 Setting of parameters for the transmission gap pattern sequence with purpose "TDD measurements"

The time needed by the UE to perform the required TDD inter-frequency measurements according to what has been requested by the UTRAN depends on the transmission gap pattern sequence characteristics such as e.g. TGD, TGPL and TGPRC. The rules to derive these measurement times are given in [16].

5.1.6.2.2.2 Void

5.1.6.2.3 Monitoring of GSM cells

In the context of the measurements, the term GSM refers to both GERAN A/Gb mode and GERAN Iu mode.

The RNC may ask a dual RAT FDD/GSM UE to perform measurements of inter-RAT GSM cells to perform handover to GSM. In such case, UTRAN signals the inter-RAT neighbour cell list, and if needed, the compressed mode parameters used to make the needed measurements, to the UE.

The involved measurements are covered by three measurement purposes "GSM carrier RSSI measurements" (Subclause 5.1.6.2.3.1), "GSM Initial BSIC identification" (Subclause 5.1.6.2.3.2) and "GSM BSIC re-confirmation" (Subclause 5.1.6.2.3.3). A different transmission gap pattern sequence is supplied for each measurement purpose. This implies that when the UE is monitoring GSM, up to three transmission gap pattern sequences can be activated by the UTRAN at the same time.

5.1.6.2.3.1 Setting of parameters for transmission gap pattern sequence with purpose "GSM carrier RSSI measurement"

In order to fulfil the expected GSM power measurements requirement, the UE can get effective measurement samples during a time window of length equal to the transmission gap length reduced by an implementation margin that includes the maximum allowed delay for a UE's synthesiser to switch from one FDD frequency to one GSM frequency and switch back to FDD frequency, plus some additional implementation margin.

The number of samples that can be taken by the UE during the allowed transmission gap lengths and their distribution over the possible GSM frequencies are given in [16].

5.1.6.2.3.2 Setting of parameters for transmission gap pattern sequence with purpose "GSM Initial BSIC identification"

The setting of the compressed mode parameters that are described in this subclause are used for the first SCH decoding of a GSM cell when there is no knowledge about the relative timing between the current FDD cells and the neighbouring GSM cell.

The table below gives a set of reference transmission pattern gap sequences that might be used to perform BSIC identification i.e. initial FCCH/SCH acquisition.

The time available to the UE to perform BSIC identification is equal to the transmission gap length minus an implementation margin that includes the maximum allowed delay for a UE's synthesiser to switch from one FDD frequency to one GSM frequency and switch back to FDD frequency, the UL/DL timing offset, and the inclusion of the pilot field in the last slot of the transmission gap for the case of downlink compressed mode.

	TGL1 [slots]	TGL2 [slots]	TGD [slots]	TGPL1 [frames]	TGPL2 [frames]	T _{identify_abort} [s]	N _{identify_abort} [patterns]
Pattern 1	7	-	undefined	3	TGPL1	1.56	52
Pattern 2	7	-	undefined	8	TGPL1	5.28	66
Pattern 3	7	7	47	8	TGPL1	2.88	36
Pattern 4	7	7	38	12	TGPL1	2.88	24
Pattern 5	14	-	undefined	8	TGPL1	1.84	23
Pattern 6	14	-	undefined	24	TGPL1	5.28	22
Pattern 7	14	14	45	12	TGPL1	1.44	12
Pattern 8	10	-	undefined	8	TGPL1	2.88	36
Pattern 9	10	10	75	12	TGPL1	2.88	24

For the above listed compressed mode patterns sequences, N_{identify_abort} indicates the maximum number of patterns from the transmission gap pattern sequence which may be devoted by the UE to the identification of the BSIC of a given cell. T_{identify_abort} times have been derived assuming the serial search and two SCH decoding attempts since the parallel search is not a requirement for the UE.

Each pattern corresponds to a different compromise between speed of GSM SCH search and rate of use of compressed frames. Requirements are set in [16] to ensure a proper behaviour of the UE depending on the signalled parameters.

5.1.6.2.3.3 Setting of parameters for transmission gap pattern sequence with purpose "GSM BSIC re-confirmation"

BSIC re-confirmation is performed by the UE using a separate compressed mode pattern sequence (either the same as for BSIC identification or a different one). When the UE starts BSIC re-confirmation for one cell using the compressed

mode pattern sequence signalled by the UTRAN, it has already performed at least one decoding of the BSIC (during the initial BSIC identification).

UTRAN may have some available information on the relative timing between GSM and UTRAN cells. Two alternatives are considered for the scheduling of the compressed mode pattern sequence by the UTRAN for BSIC re-confirmation depending on whether or not UTRAN uses the timing information provided by the UE.

The requirements on BSIC re-confirmation are set in [16] independently of how the transmission gap pattern sequence are scheduled by the UTRAN. These requirements apply when the GSM SCH falls within the transmission gap of the transmission gap pattern sequence with a certain accuracy. The UTRAN may request the UE to re-confirm several BSICs within a given transmission gap.

For the reference transmission gap pattern sequences that might be used for BSIC re-confirmation listed in the table below, $T_{\text{re-confirm_abort}}$ indicates the maximum time allowed for the re-confirmation of the BSIC of one GSM cell in the BSIC re-confirmation procedure, assuming a worst-case GSM timing. This parameter is signalled by the UTRAN to the UE with the compressed mode parameters.

	TGL1 [slots]	TGL2 [slots]	TGD [slots]	TGPL1 [frames]	TGPL2 [frames]	$T_{\text{re-confirm_abort}}$ [s]	$N_{\text{re-confirm_abort}}$ [patterns]
Pattern 1	7	-	undefined	3	TGPL1	1.32	44
Pattern 2	7	-	undefined	8	TGPL1	5.04	63
Pattern 3	7	-	undefined	15	TGPL1	8.1	54
Pattern 4	7	7	69	23	TGPL1	10.12	44
Pattern 5	7	7	69	8	TGPL1	2.64	33
Pattern 6	14	-	undefined	8	TGPL1	1.6	20
Pattern 7	14	14	60	8	TGPL1	0.80	10
Pattern 8	10	-	undefined	8	TGPL1	2.64	33
Pattern 9	10	-	undefined	23	TGPL1	8.05	35
Pattern 10	7	7	47	8	TGPL1	2.64	33
Pattern 11	7	7	38	12	TGPL1	2.64	22
Pattern 12	14	-	undefined	24	TGPL1	5.04	21
Pattern 13	14	14	45	12	TGPL1	1.20	10
Pattern 14	10	-	undefined	13	TGPL1	4.94	38
Pattern 15	10	10	75	12	TGPL1	2.64	22

5.1.6.2.3.3.1 Asynchronous BSIC reconfirmation

In this case, the UTRAN provides a transmission gap pattern sequence without using information on the relative timing between UTRAN and GSM cells.

The way the UE should use the compressed mode pattern for each cell in case the BSIC re-confirmation is required for several cells is configured by the UTRAN using the $N_{\text{identify_abort}}$ parameter, which is signalled with the transmission gap pattern sequence parameters. Requirements are set in [16] to ensure a proper behaviour of the UE depending on the signalled parameters.

5.1.6.2.3.3.2 Synchronous BSIC reconfirmation

When UTRAN has prior timing information, the compressed mode can be scheduled by upper layers with the intention that SCH(s) (or FCCH(s) if needed) of one or several specific GSM cells can be decoded at the UE during the transmission gap(s) i.e. the transmission gap(s) are positioned so that the SCH(s) of the target GSM cell(s) are in the middle of the effective measurement gap period(s). Which BSIC is to be re-confirmed within each gap is not explicitly signalled, but determined by the UE based on prior GSM timing measurements.

5.1.7 Transfer of RRC information across interfaces other than Uu

5.1.7.1 Introduction and general principles

During several procedures, e.g. handover to UTRAN, handover from UTRAN, SRNC relocation RRC information may need to be transferred across interfaces other than the UTRA air interface (Uu), e.g. Iu, A, Um interface. In order to maintain independence between the different protocols, to facilitate transparent handling by intermediate network nodes

and to ease future extension, the preference is to use RRC information containers across such interfaces. In some cases however RRC messages may be used, e.g. for historical reasons.

An RRC information container is an extensible self-contained information unit that can be decoded without requiring information about the context, e.g. in which interface message it was included. In general an RRC information container is defined for each node that terminates/receives RRC information, e.g. the source RAT, target RNC. By definition, an RRC information container includes a choice facilitating the transfer of different types of RRC information.

In the following a typical example of an RRC information container is provided:

```
-- *****
--
-- RRC information, to target RNC
--
-- *****
-- RRC Information to target RNC sent either from source RNC or from another RAT

ToTargetRNC-Container ::= CHOICE {
    InterRATHandover                InterRATHandoverInfoWithInterRATCapabilities,
    srncRelocation                  SRNC-RelocationInfo,
    extension                        NULL
}
```

The term RRC message is used for the RRC information identified by a choice value, e.g. HANDOVER TO UTRAN COMMAND, INTER RAT HANDOVER INFO. The characteristics and handling defined for these RRC messages to a large extent resemble the RRC messages transferred across the Uu interface. The specification focuses on UE requirements. Hence, RRC messages that originate from/terminate in the UE/MS are treated in the main clauses (clauses 8, 9, 10) of [9] while the other RRC messages are specified in clause 14 of [9].

As stated above, RRC information containers have been defined to limit the impact of transferring RRC information across other interfaces. Intermediate nodes transparently pass the information carried in such containers; only the originating and terminating entities process the information. This transparency makes the protocols independent. In case there is RRC information on which intermediate nodes need to act, the information elements should be introduced in the corresponding interface protocols. If the information is to be passed on to another target node also, this may result in duplication of information. For RRC information containers the same extension mechanism as defined for RRC messages applies; both critical and non-critical extensions may be added; as explained in [10]. If the extension would not be defined at RRC information container level, other interface specification would be affected whenever the RRC information would be extended.

In some cases information in containers is exchanged by peer entities that do not speak the same (protocol) language, e.g. a GSM BSC may have to exchange information with a UTRA RNC. For such cases, it has been agreed that the source/sender of the information adapts to the target/receiver, e.g. upon handover to UTRAN the BSS provides RANAP information within a Source to Target RNC transparent container.

NOTE: The handover to UTRAN info is not only transferred from UE, via BSS to target RNC but may also be returned to another BSS, to be forwarded later on to another RNC. To simplify the handling of RRC information in network nodes, it is therefore desirable to align the format of the RRC information used in both directions. The alignment of formats used in the different directions is not considered to violate these general principles, since for this information that is moved forwards and backwards it is difficult to speak of source and target anyhow.

The error handling for RRC information containers that are terminated in network nodes applies the same principles as defined for RRC messages. A network node receiving an invalid RRC information container (unknown, unforeseen or erroneous container) from another network node should return an RRC INFORMATION FAILURE message and include an appropriate cause value within IE "Protocol error cause". Although the return of a failure container is considered desirable, no compelling need has been identified to introduce support for transferring this failure container in current releases for all concerned interface protocols. In case the interface protocols do not support the failure procedure, the failure may instead be indicated by means of a cause value that is already defined within the interface protocol.

5.1.7.2 Message sequence diagrams

As stated before, most RRC information is carried by means of containers across interfaces other than Uu. The following sequence diagrams illustrate which RRC messages should be included within these RRC information containers used across the different network interfaces. Concerning the contents of RRC messages, i.e. when optional

IEs should be included, requirements are specified in TS 25.331 only for the RRC messages originated/terminated in the UE, since the RRC specification focuses on UE requirements.

NOTE: In order to maintain independence between protocols, no requirements are included in the interface protocols that are used to transfer the RRC information.

For each of the different message sequences not only the details on the RRC information transferred are provided, but also deviations from the general principles described in the previous are highlighted. One common deviation from the general principles is that containers are not used for any RRC information transferred across the GSM air interface; in all these cases RRC messages are used instead (mainly for historical reasons).

The following four figures illustrate the message sequence for the handover to UTRAN procedure:

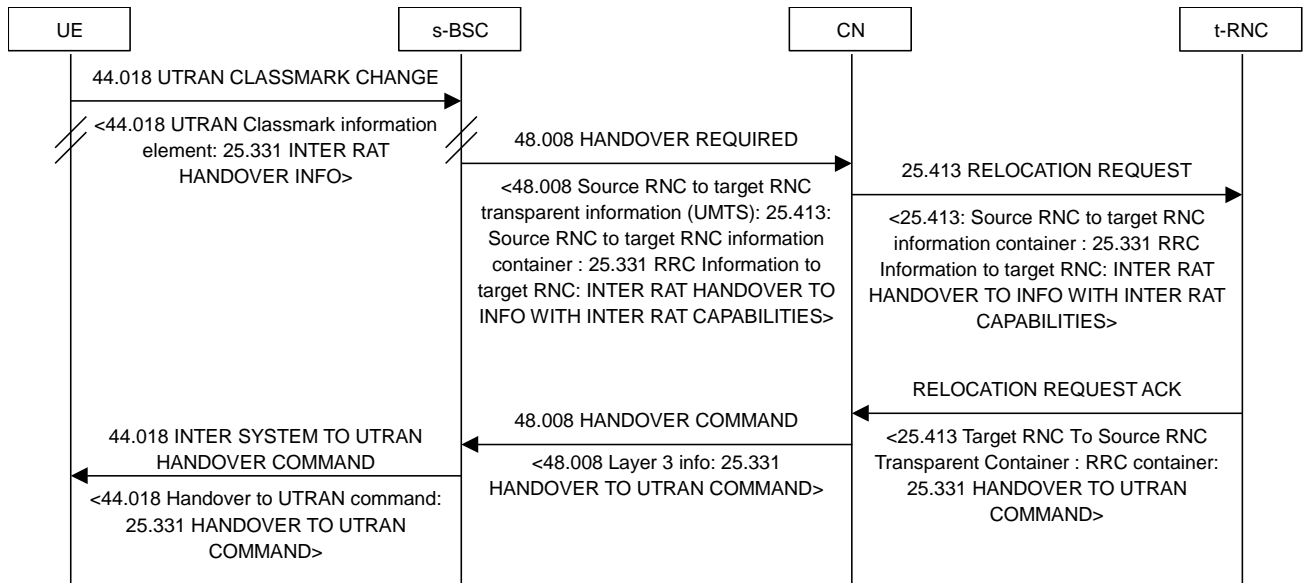

Figure 5.1.7.2-1: Handover of CS domain service from GERAN A/Gb mode to UTRAN, normal flow

As can be seen in the previous figure, the RRC information transfer within the handover from GERAN A/Gb mode to UTRAN procedure deviates from the common principles in the following areas:

- Containers are not used to transfer the HANDOVER TO UTRAN COMMAND message across the Iu and the A-interface.

For handover of CS domain service from GAN mode to UTRAN the procedures are the same as shown in Figure 5.1.7.2-1 above except that the s-BSC is replaced with s-GANC, the UE/MS sends a GA-CSR UTRAN CLASSMARK CHANGE message and the s-GANC sends GA-CSR HANDOVER COMMAND. Detailed procedures for CS handover from GAN mode to UTRAN are described in [33].

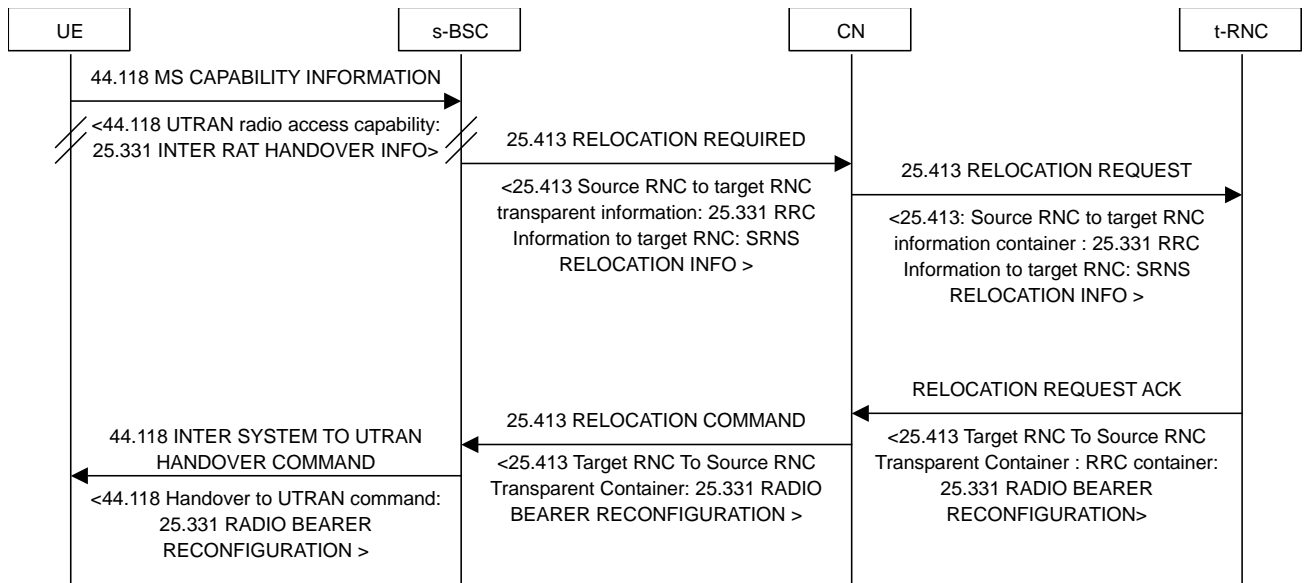

Figure 5.1.7.2-1a: Handover from GERAN lu mode to UTRAN, normal flow

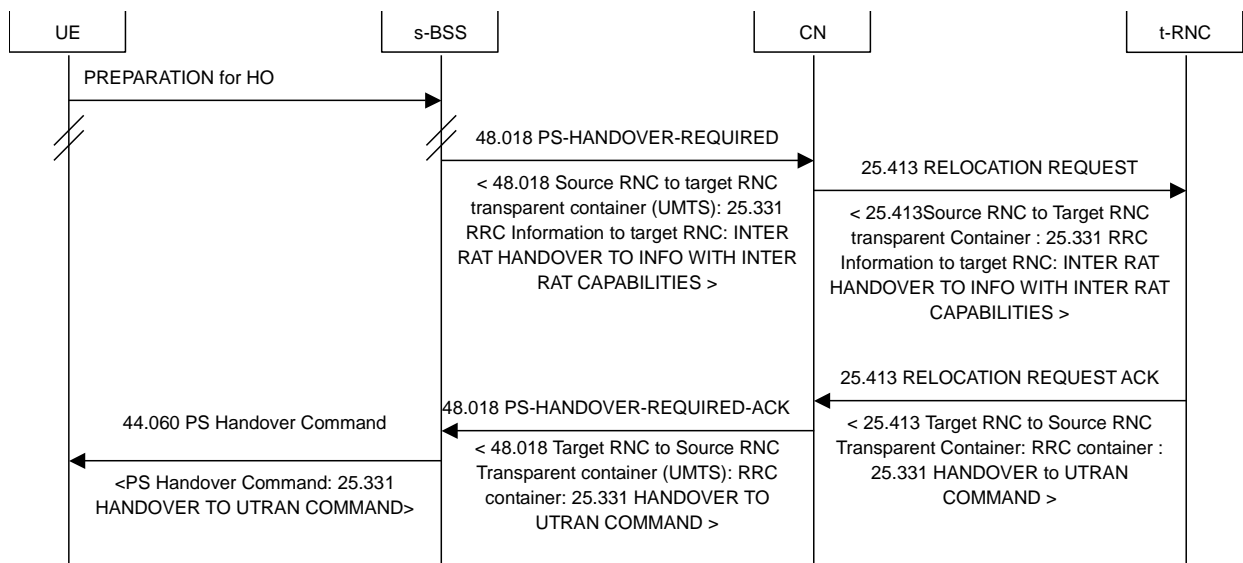

Figure 5.1.7.2-1b. Handover of PS domain service from GERAN A/Gb mode to UTRAN, normal flow

For handover of PS domain service from GAN mode to UTRAN the procedures are the same as shown in Figure 5.1.7.2-1b above except that the s-BSS is replaced with s-GANC and the UE/MS is sent a GA-PSR HANDOVER COMMAND message to trigger PS handover from the source GAN cell. Detailed procedures for PS handover from GAN mode to UTRAN are described in [25].

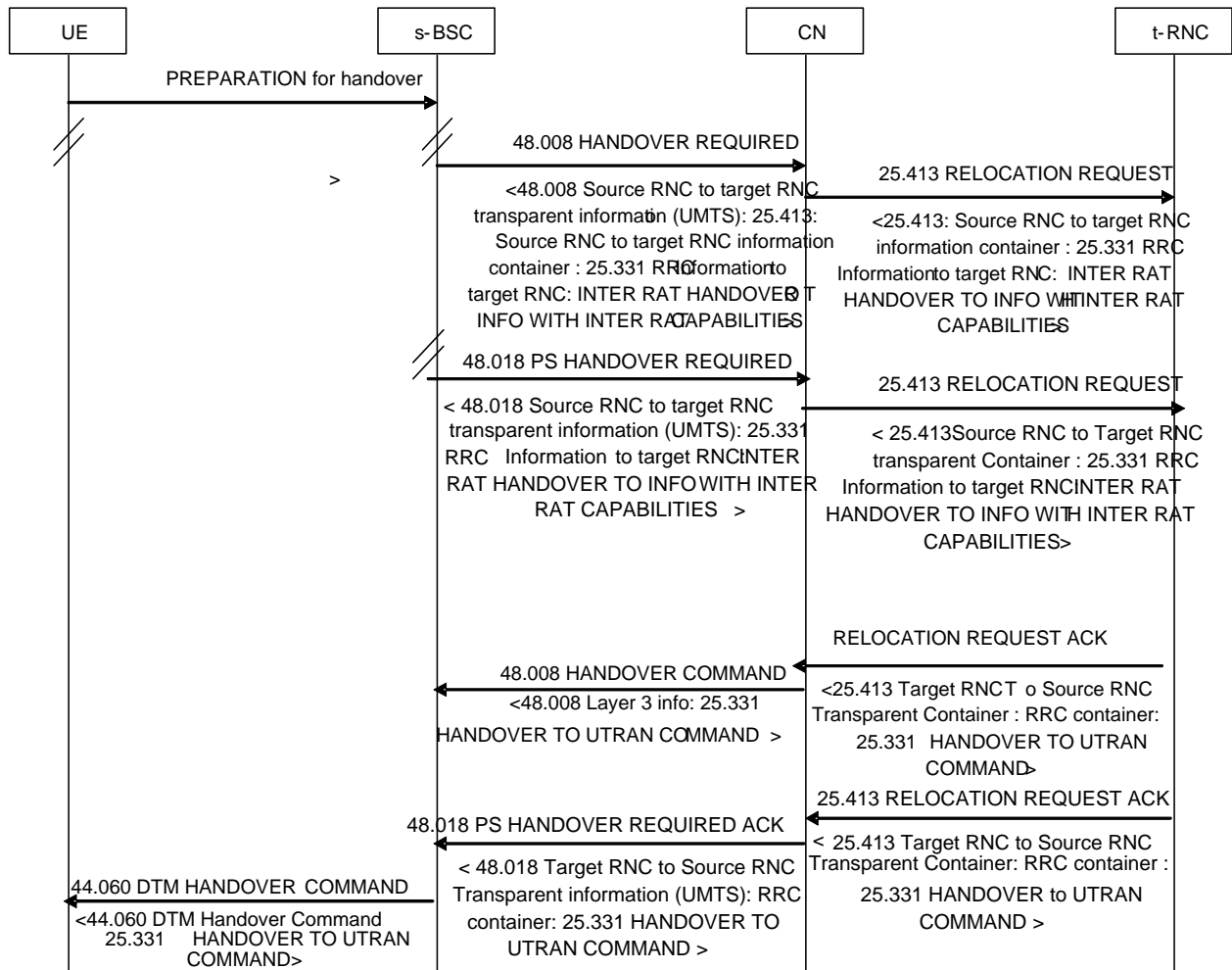

Figure 5.1.7.2-1c. Inter-RAT DTM Handover from GERAN A/Gb mode to UTRAN, normal flow

The following four figures illustrate the message sequence for the handover from UTRAN procedure:

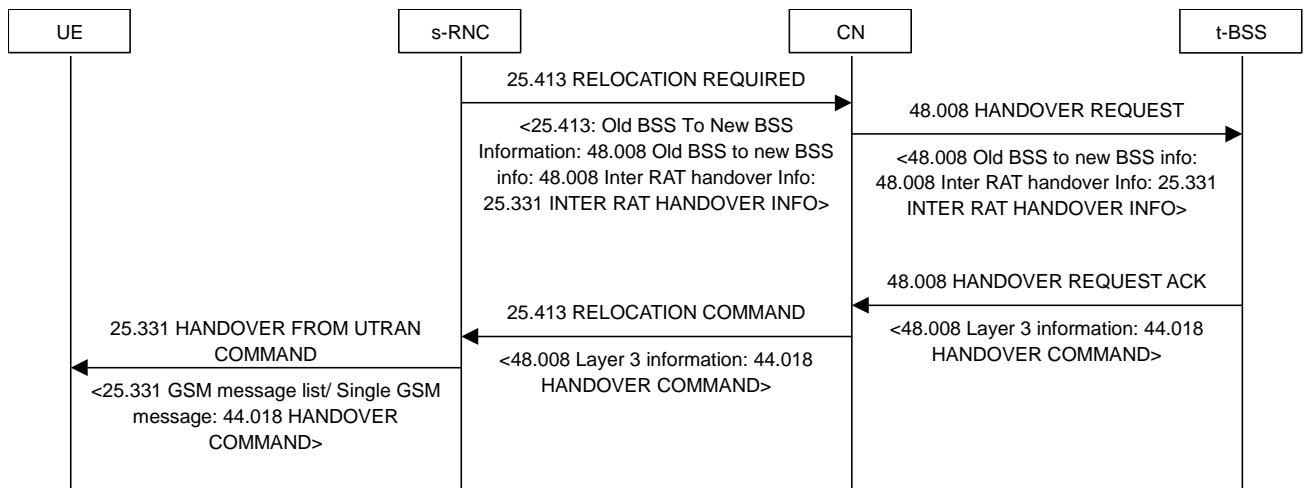

Figure 5.1.7.2-2: Handover of CS domain service from UTRAN to GERAN A/Gb mode, normal flow

As can be seen in the previous figure, the RRC information transfer within the handover from UTRAN to GERAN A/Gb mode procedure deviates from the common principles in the following areas:

- Containers are not used to transfer the INTER RAT HANDOVER INFO message across the Iu and the A- interface.

For handover of CS domain service from UTRAN to GAN mode the procedures are the same as shown in Figure 5.1.7.2-2 above except that the t-BSS is replaced with t-GANC. Detailed procedures for CS handover from UTRAN to GAN mode are described in [33].

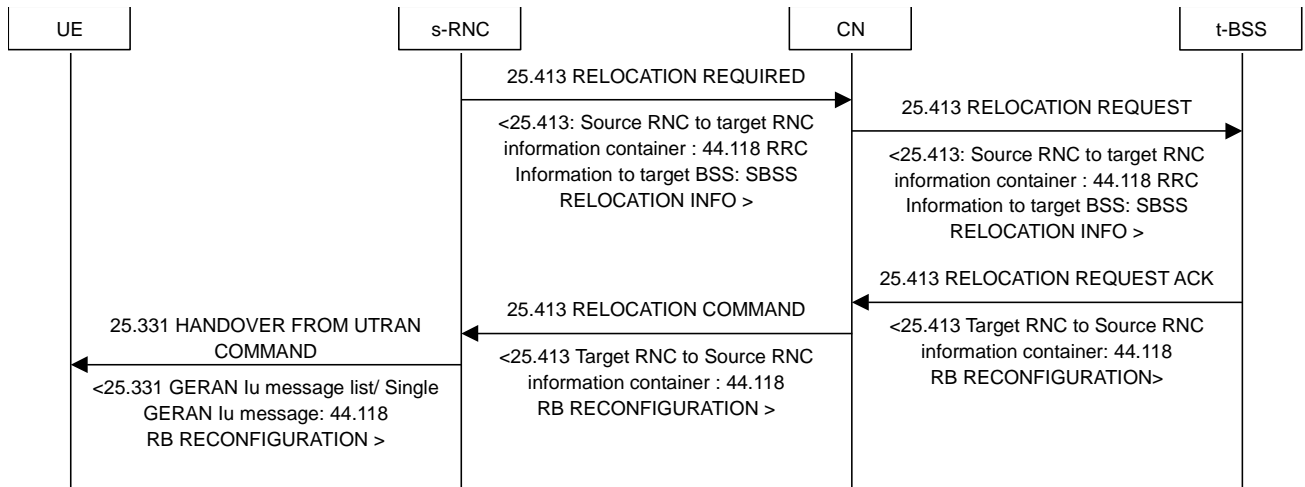

Figure 5.1.7.2-2a: Handover from UTRAN to GERAN lu mode, normal flow

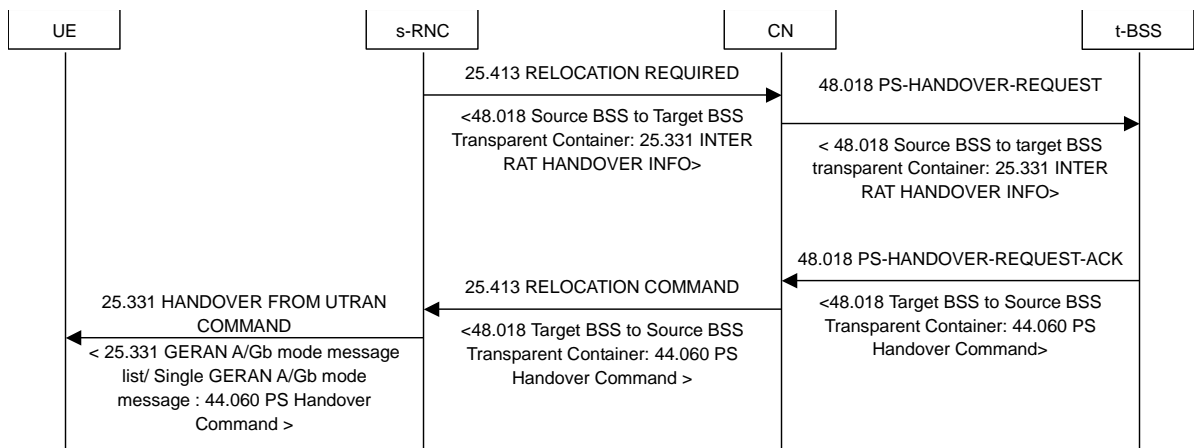

Figure 5.1.7.2-2b. Handover of PS domain service from UTRAN to GERAN A/Gb mode, normal flow

For handover of PS domain service from UTRAN to GAN mode the procedures are the same as shown in Figure 5.1.7.2-2b above except that the t-BSS is replaced with t-GANC and the UE/MS is sent a PS Handover Command message within the HANDOVER FROM UTRAN COMMAND message. Detailed procedures for PS handover from UTRAN to GAN mode are described in [25].

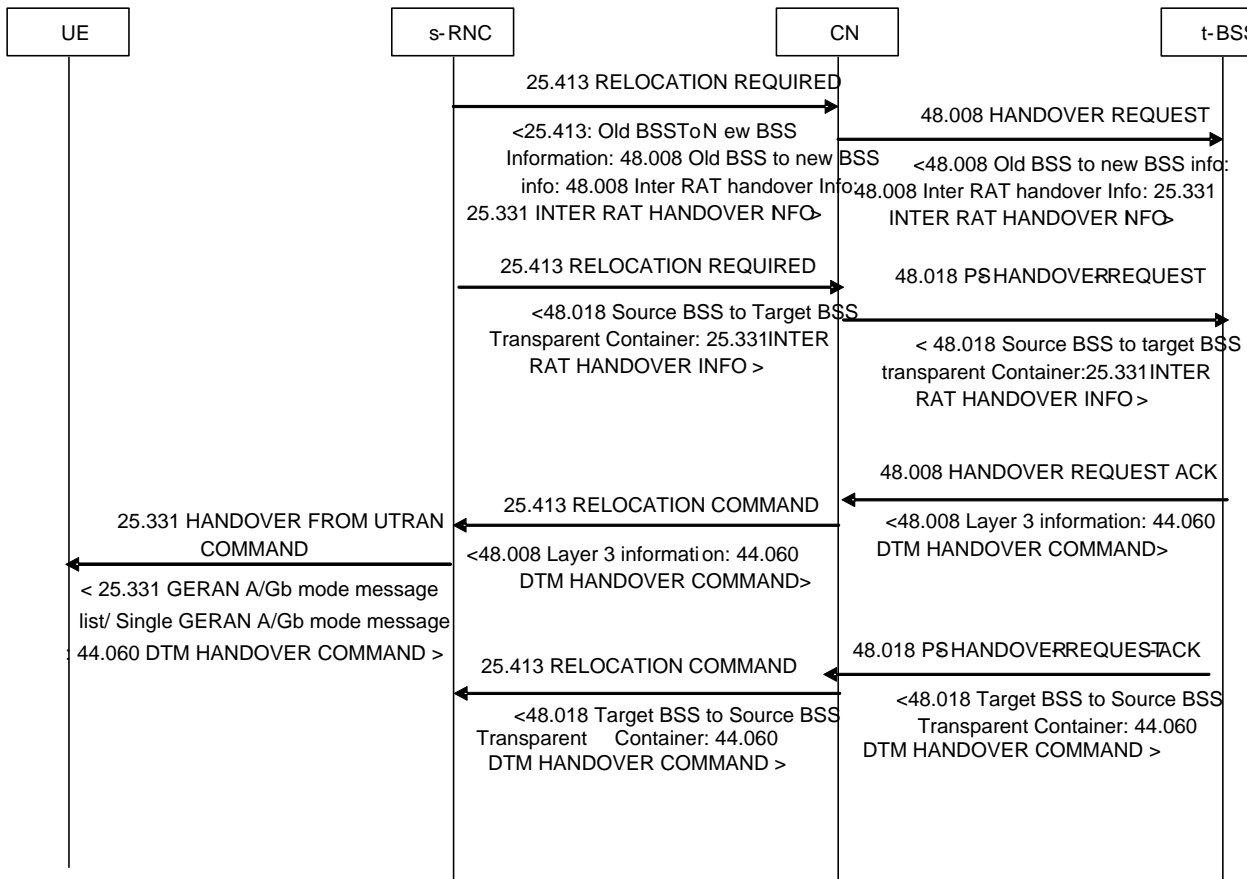

Figure 5.1.7.2-2c. Inter-RAT DTM handover from UTRAN to GERAN A/Gb mode, normal flow

The following figure illustrates the message sequence for the SRNS relocation procedure:

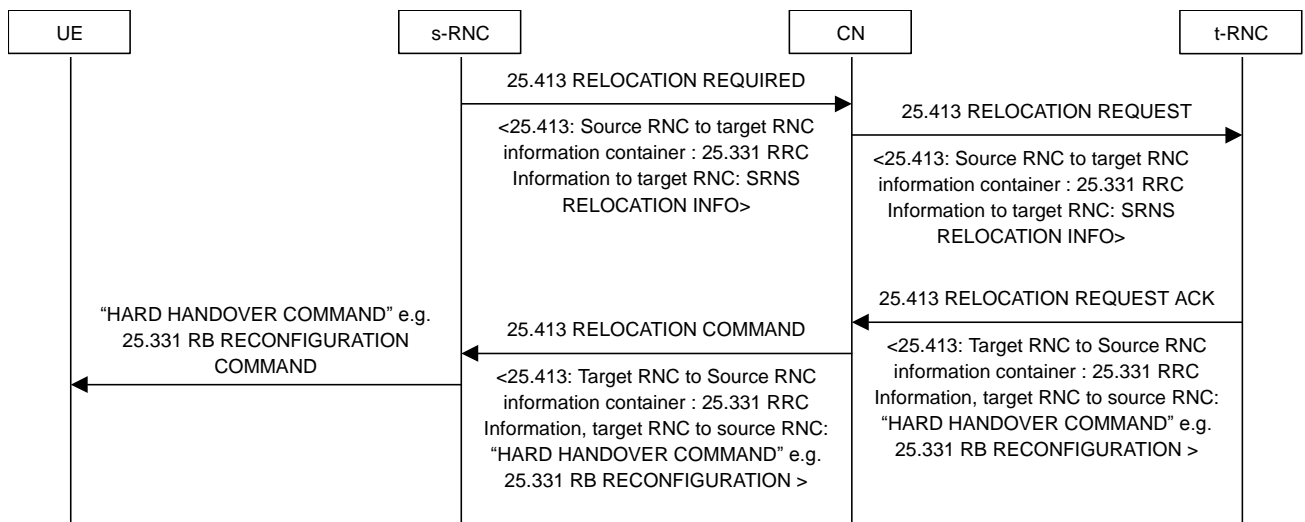

Figure 5.1.7.2-3: SRNS relocation, normal flow

The following figures illustrate the message sequence for the SRNS relocation procedure, including the transfer of ROHC context information.

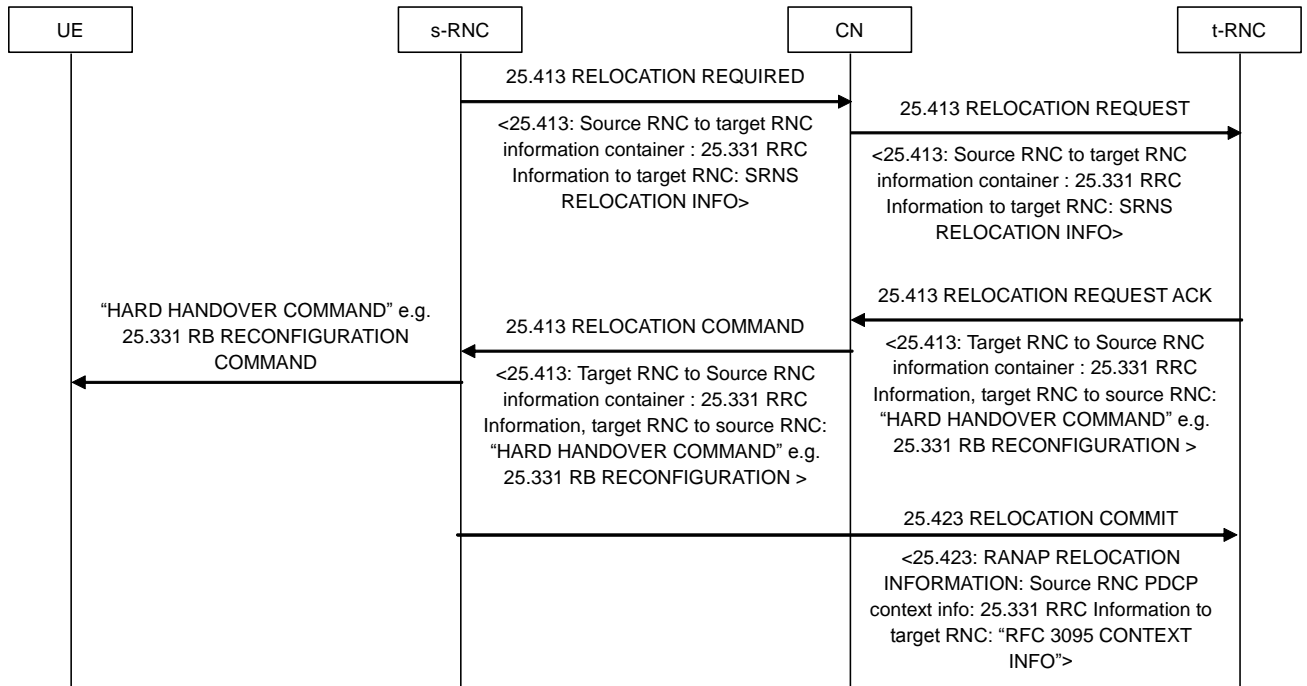

Figure 5.1.7.2-3a: SRNS relocation, flow with context relocation info in RELOCATION COMMIT

The above is based on figure 39 in [28], which applies for the case of combined Hard Handover and (intra-SGSN or inter-SGSN) SRNS Relocation procedure for the PS domain with the control signalling transferred via the Iur interface.

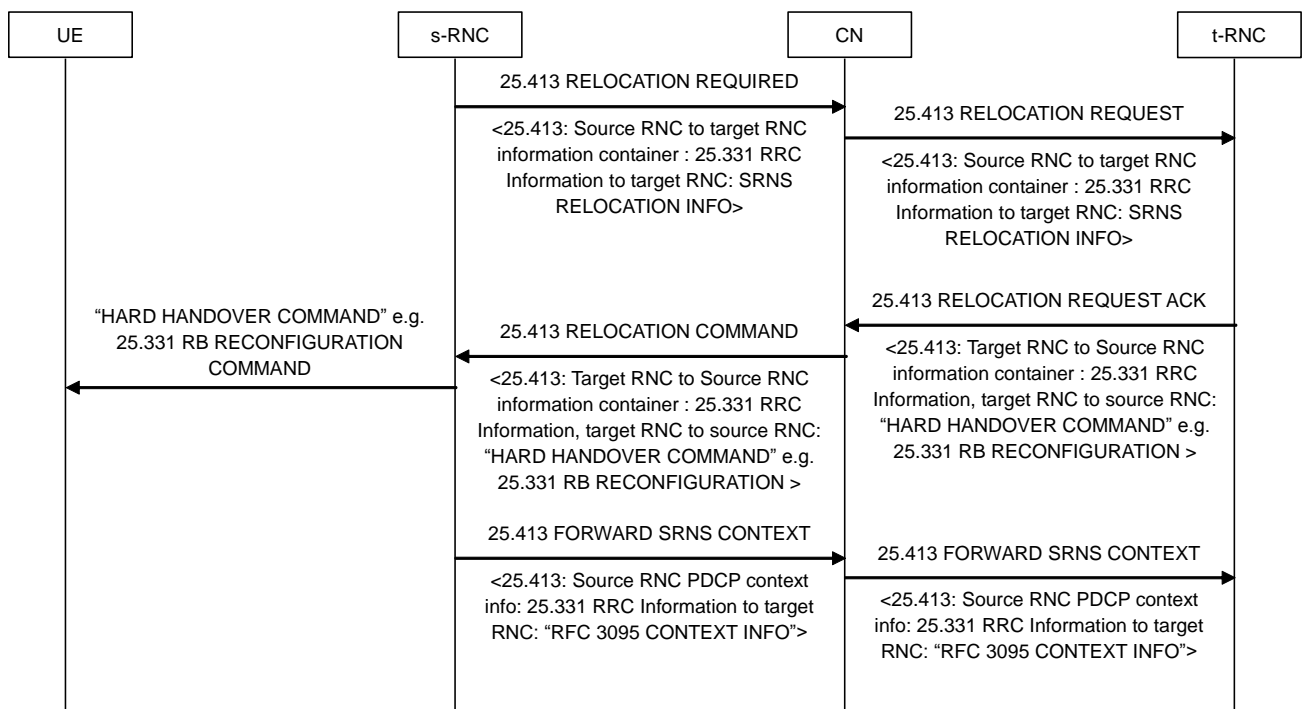

Figure 5.1.7.2-3b: SRNS relocation, flow with context relocation info in FORWARD SRNS CONTEXT

The above is based on figure 42 in [28], which applies for the case of combined Hard Handover and (intra-SGSN or inter-SGSN) SRNS Relocation procedure for the PS domain with the control signalling forwarded through the CN.

As can be seen in the previous figure, the RRC information transfer within the SRNS relocation procedure does not deviate from the common principles.

The following two figures, showing the message sequence for the inter BSC handover (GERAN A/Gb mode) and SBSS relocation (GERAN Iu mode), are provided for completeness.

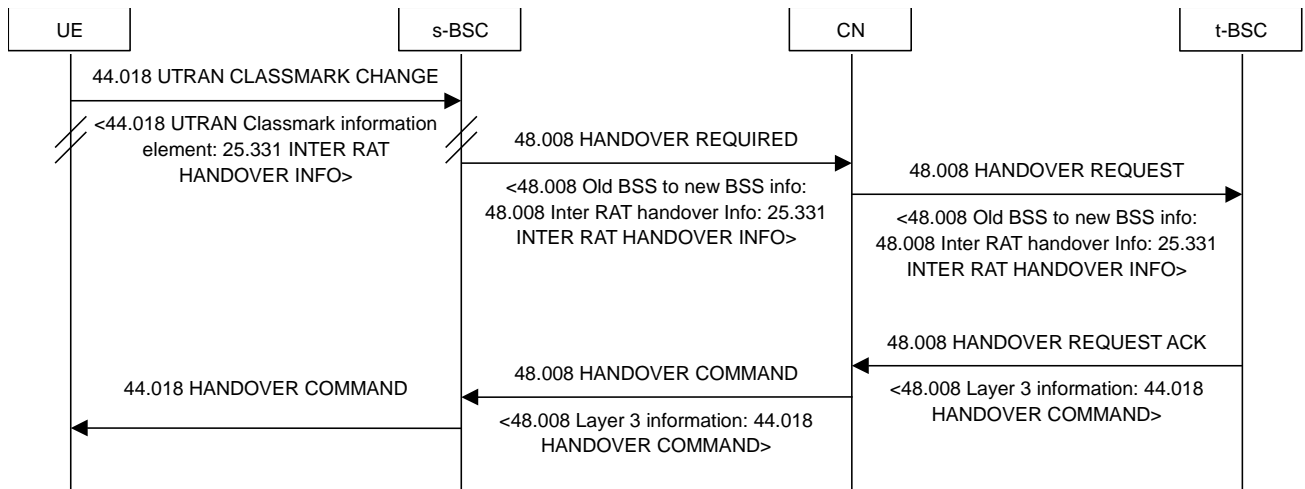

Figure 5.1.7.2-4: Inter BSC handover, GERAN A/Gb mode, normal flow

As can be seen in the previous figure, the RRC information transfer within the inter BSC handover procedure deviates from the common principles in the following areas:

- Containers are not used to transfer the INTER RAT HANDOVER INFO message across the A-interface.

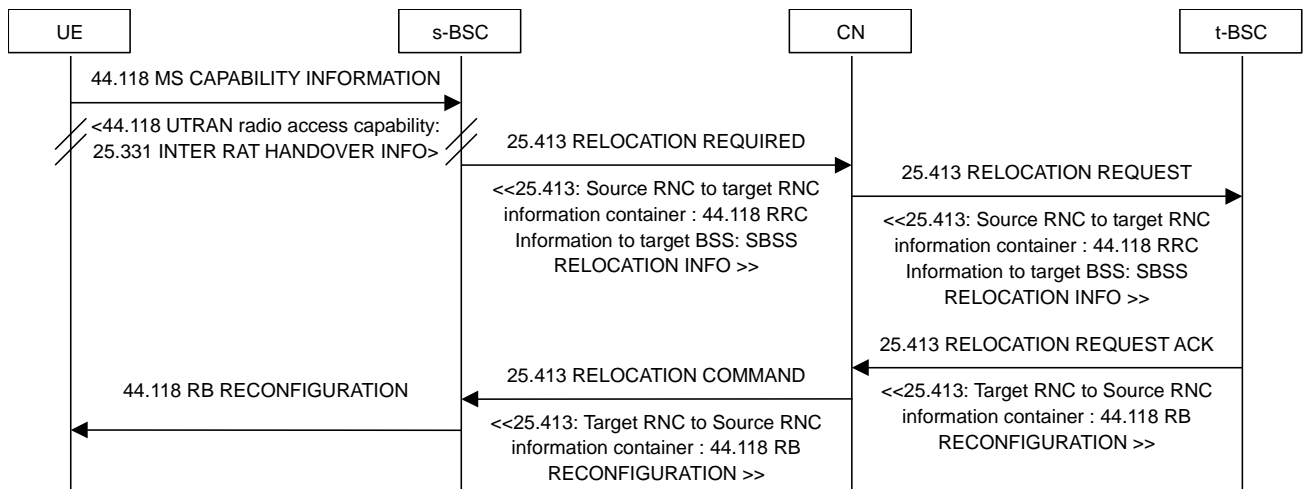

Figure 5.1.7.2-4a: SBSS relocation, GERAN Iu mode, normal flow

5.1.7.3 General error handling for RRC containers

As indicated in the previous sections, the characteristics and the handling of RRC messages transferred across other interfaces than Uu is the same as that of regular RRC messages. This equally applies for the extension of such messages as well as for the related general error handling. In this section four generic error handling cases are distinguished that have distinct characteristics that are specific to RRC containers.

RRC message sent by UE via another RAT

As for regular messages, only non-critical extensions apply in uplink. Upon not comprehending a non-critical extension, the receiver just ignores this information and processes the other parts as if the not comprehended extension was absent. Hence, it is not applicable to use a RRC FAILUREINFO message in the reverse direction.

For the HANDOVER TO UTRAN INFO message, the BSS not only transparently passes the information received from the UE, but also adds information and includes it in an RRC container to be forwarded to the target RNC. For

information originated and terminated in a network nodes both critical and non-critical extensions apply. Since critical extensions applies for the information inserted by the BSS, they also apply for the HANDOVER TO UTRAN INFO WITH INTER RAT CAPABILITIES message that includes them. The corresponding RRC FAILURE INFO message would be terminated in the BSS.

RRC container information terminated in UE (HANDOVER TO UTRAN COMMAND)

In case of a not comprehended critical extension, the UE shall reject the handover and return a failure message towards the BSC. The RRC procedure also states that a RRC FAILURE INFO message should be included, depending on system specific procedures. The (network) interface signalling procedures do not support the transfer of this RRC message which is not a problem since the extension mechanism does not require it. Instead a cause value may be returned.

If the INTER SYSTEM TO UTRAN HANDOVER FAILURE message used across the GSM air interface would support the transfer of the RRC FAILURE INFO message, the RRC message would not be passed beyond the source BSC since there are no further signalling procedures. However, when needed, this failure information may be transferred to the t-RNC in a subsequent attempt to perform handover for the same UE and to the same RNC. To accommodate this, the HANDOVER TO UTRAN INFO message may include the failure information. This is illustrated in the following figure:

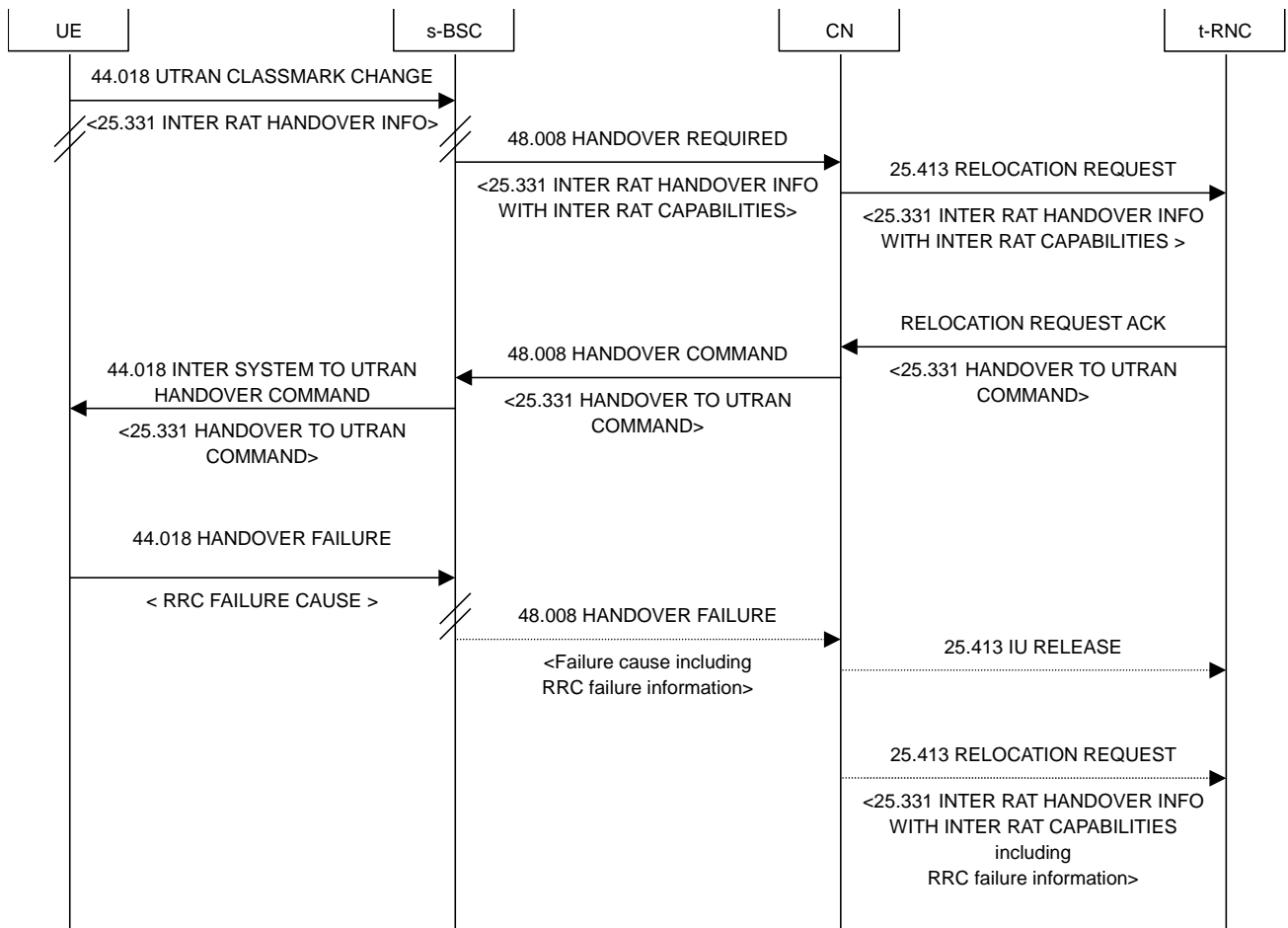

Figure 5.1.7.3-1: Handover of CS domain service from GERAN A/Gb mode to UTRAN, failure due to critical extension not supported by UE

For handover of CS domain service from GAN mode to UTRAN the failure procedures are the same as for GERAN A/Gb mode to UTRAN shown in Figure 5.1.7.3-1 above except that the s-BSC is replaced with a s-GANC, UE/MS sends a GA-CSR UTRAN CLASSMARK CHANGE message, the s-GANC sends GA-CSR HANDOVER COMMAND and the UE/MS sends a GA-CSR HANDOVER FAILURE message. Detailed failure procedures for CS handover from GAN mode to UTRAN are described in [34].

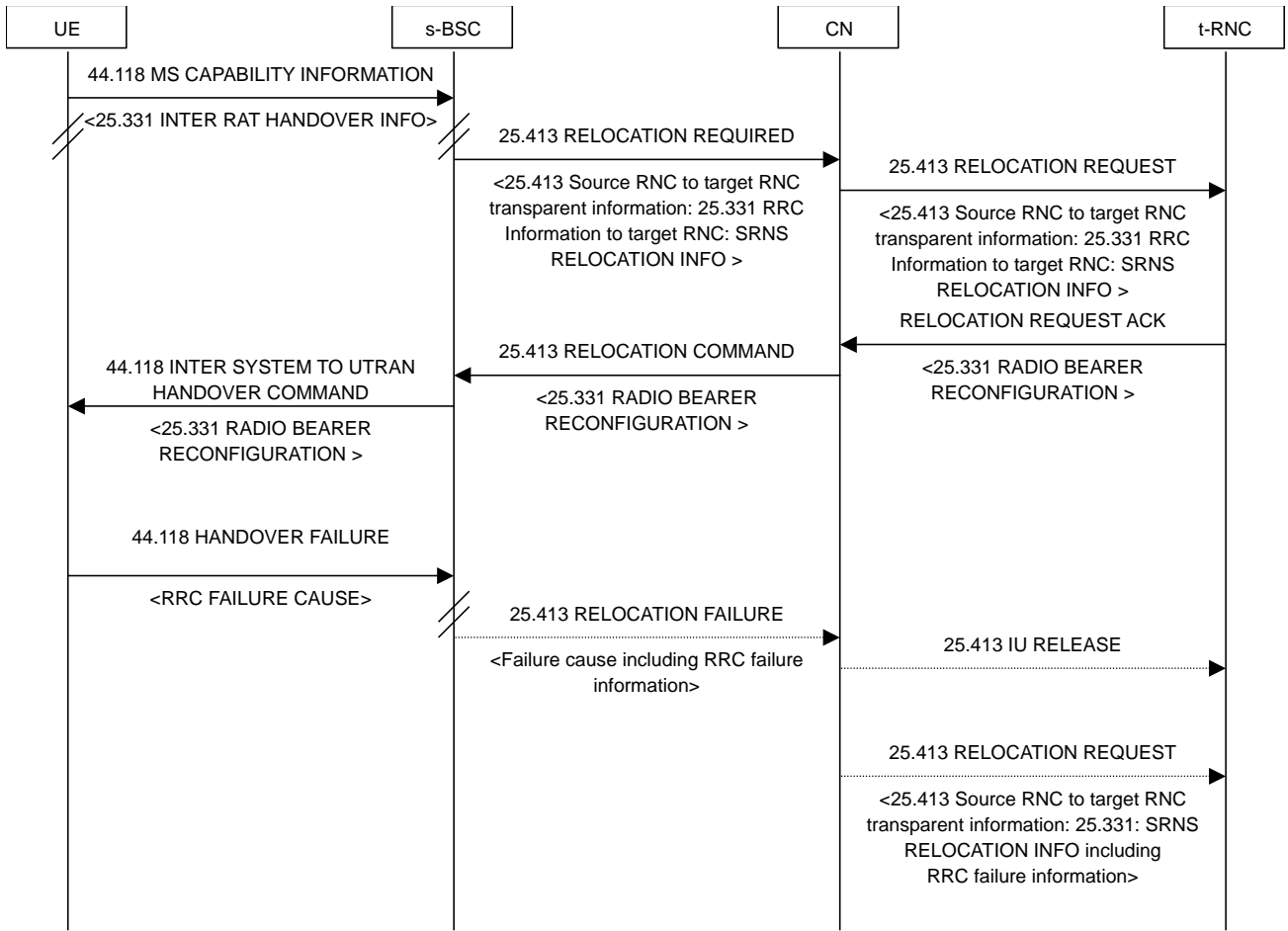

Figure 5.1.7.3-1a: Handover from GERAN Iu mode to UTRAN, failure due to critical extension not supported by UE

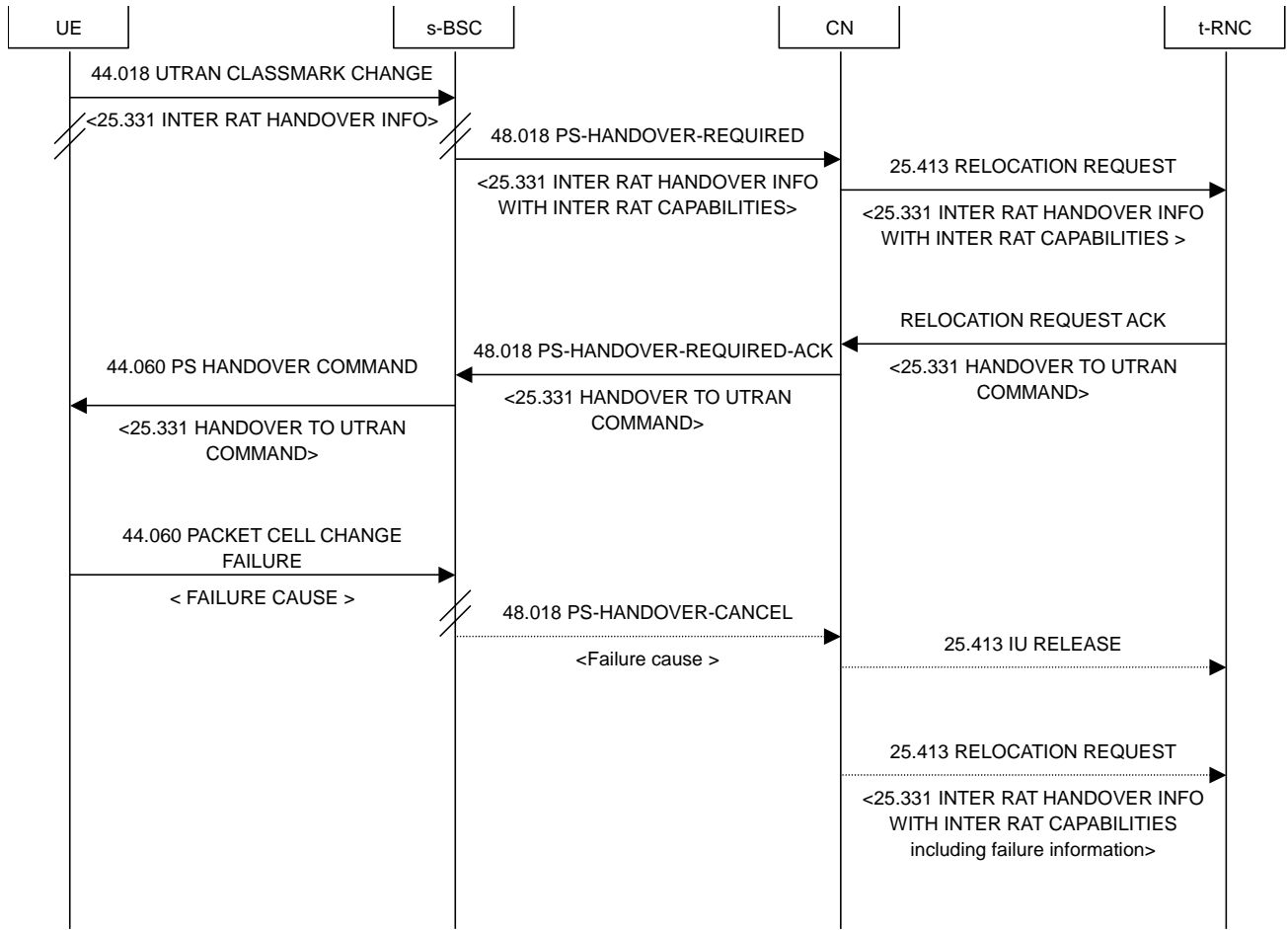

Figure 5.1.7.3-1b: Handover of PS domain service from GERAN A/Gb mode to UTRAN, failure due to critical extension not supported by UE

For handover of PS domain service from GAN mode to UTRAN the failure procedures are the same as for GERAN A/Gb mode to UTRAN shown in Figure 5.1.7.3-1b above except that the s-BSC is replaced with a s-GANC, UE/MS sends a GA-CSR UTRAN CLASSMARK CHANGE message, the s-GANC sends a GA-PSR HANDOVER COMMAND message and the UE/MS sends a GA-PSR HANDOVER FAILURE message. Detailed failure procedures for PS handover from GAN mode to UTRAN are described in [25].

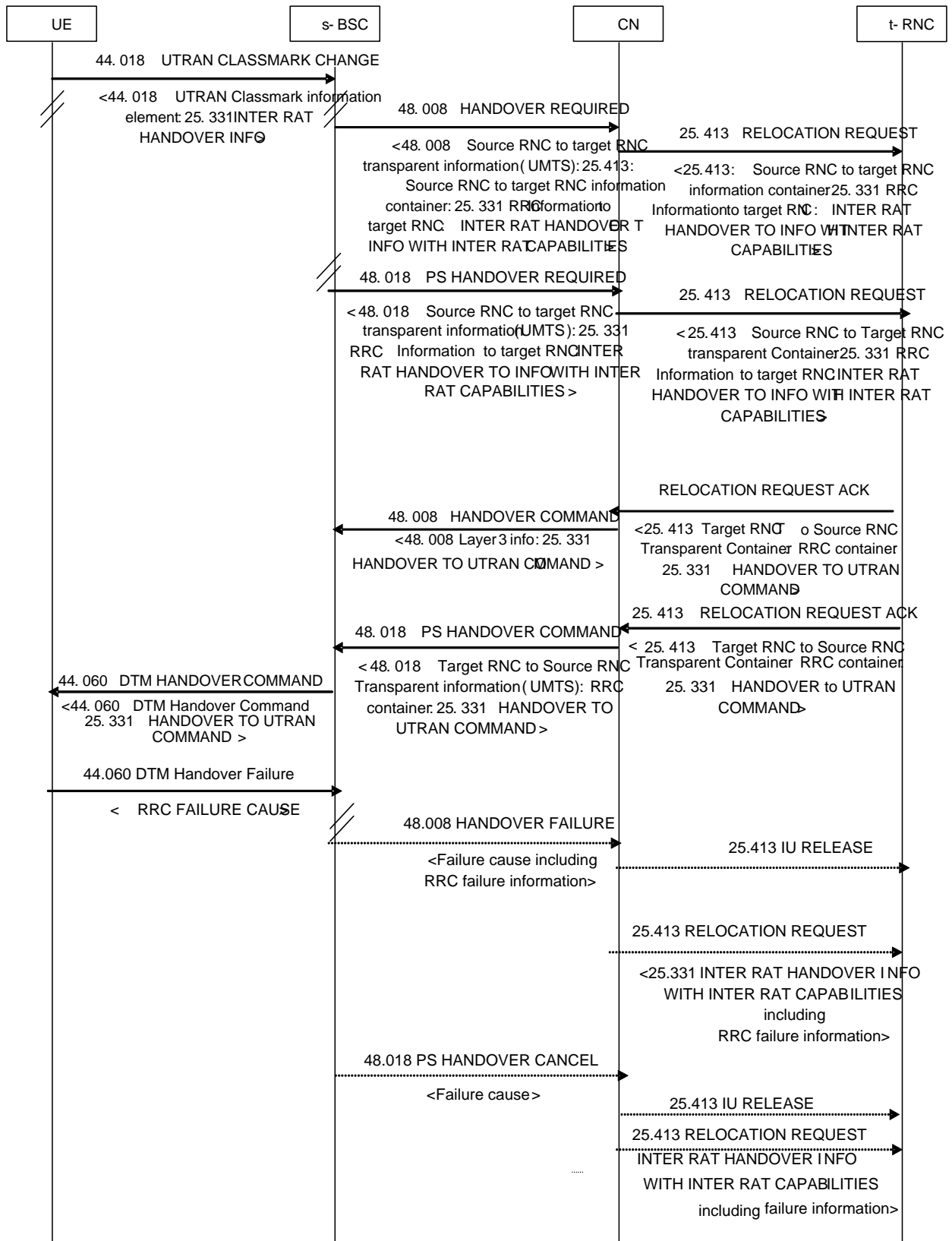

Figure 5.1.7.3-1c: Inter-RAT DTM Handover from GERAN A/Gb mode to UTRAN, failure due to critical extension not supported by UE

RRC container information terminated in network (SRNS relocation info & commands)

This case is basically the same as for the handover to UTRAN command, although in this case the container is really terminated by the s-RNC. Nevertheless, in case the hard handover command includes a critical extension that the UE does not comprehend, it will notify the s-RNC by means of the applicable failure message including IE "Protocol error cause" set to "Message extension not comprehended". If a failure notification is desired towards the t-RNC upon a subsequent attempt to perform the handover, the s-RNC has to generate this based on the received protocol error information.

6 Admission Control

6.1 Introduction

In CDMA networks the 'soft capacity' concept applies: each new call increases the interference level of all other ongoing calls, affecting their quality. Therefore it is very important to control the access to the network in a suitable way. This strategy is named Call Admission Control - CAC.

6.2 Examples of CAC strategies

Policy 1: Admission Control is performed according to the Quality of Service.

A "Type of service" can be defined as an implementation specific category derived from standardised QoS parameters [24].

The following table illustrates this concept:

Table 6-0

Type of service	QoS class	Delay	Guaranteed bit-rate
Premium	Conversational	Low	Yes
Assured Service	Streaming	Medium	Yes
Best Effort	Interactive/Background	-	No

With this approach the estimation about the resource allocation and the for the new call is based on the required quality of service.

Table 6-1:

Service	CN Domain	Type of service	CAC performed
Voice	CS	Premium	YES
	PS	Premium	YES
Web	PS	Assured Service	YES
	PS	Best Effort	NO

Other mappings are possible like for instance

Table 6-2

CN Domain	Type of service	CAC performed
CS	Premium	YES
PS	Best Effort	NO

Policy 2: Admission Control is performed according to the current system load and the required service.

The call should be blocked if none of the suitable cells can efficiently provide the service required by the UE at call set up (i.e., if, considering the current load of the suitable cells, the required service is likely to increase the interference level to an unacceptable value). This would ensure that the UE avoids wasting power affecting the quality of other communications.

In this case, the network can initiate a re-negotiation of resources of the on-going calls in order to reduce the traffic load.

6.2.1 CAC for handover

When resources have to be allocated in order to accommodate an incoming handover, different policies can be applied:

Policy 1: To treat handover calls in the same way as new calls generated in the cell;

Policy 2: To provide higher priority to handover calls, e.g. by setting higher admission control threshold with respect to the new calls.

Policy 3: To avoid admission control for handover calls so that handover request are always accepted in the cell.

6.3 Scenarios

6.3.1 CAC performed in SRNC

Figure 6-1 is to be taken as an example. It describes the general scheme that involves Admission Control when no Iur is used and the CRNC takes the role of SRNC.

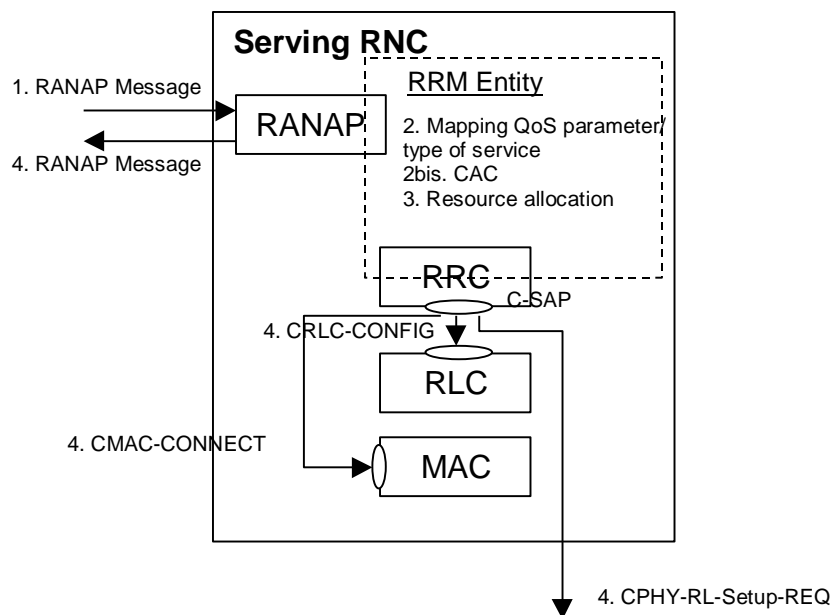

Figure 6-1: This model shows how standardised RANAP and RRC layers are involved in the CAC process

1. CN requests SRNC for establishing a RAB indicating QoS parameters.
2. According to QoS parameters the requested service is assigned a type of service. CAC is performed according to the type of service.
3. Resources are allocated according to the result of CAC.
4. Acknowledgement is sent back to CN according to the result of CAC. Sublayers are configured accordingly.

Steps 2 to 4 may also be triggered by SRNC for reconfiguration purpose within the SRNC (handovers intra-RNC, channels reconfigurations, location updates).

6.3.2 CAC performed in DRNC

If a radio link is to be set up in a node-B controlled by another RNC than the SRNC a request to establish the radio link is sent from the SRNC to the DRNC. CAC is always performed in the CRNC, and if Iur is to be used as in this example, CAC is performed within the DRNC.

6.3.2.1 Case of DCH

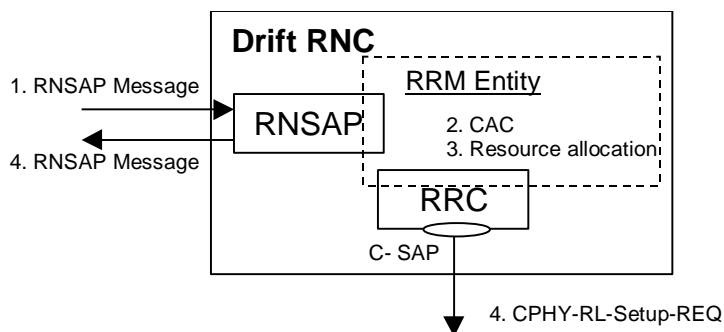

Figure 6-2: This model shows how standardised RNSAP and RRC layers are involved in the CAC process

1. SRNC requests DRNC for establishing a Radio Link, indicating DCH characteristics. These implicitly contain all QoS requirements and are enough as inputs to the CAC algorithm.
2. CAC is performed according to DCH characteristics.
3. Resources are allocated according to the result of CAC.
4. Acknowledgement is sent back to the SRNC according to the result of CAC.

6.3.2.2 Case of Common Transport Channels

When transmitting on Common Transport Channels a UE may camp on a new cell managed by a new RNC. SRNC is notified by UE through RRC messages that connection will be set up through a new DRNC. Subsequently SRNC initiates connection through new DRNC.

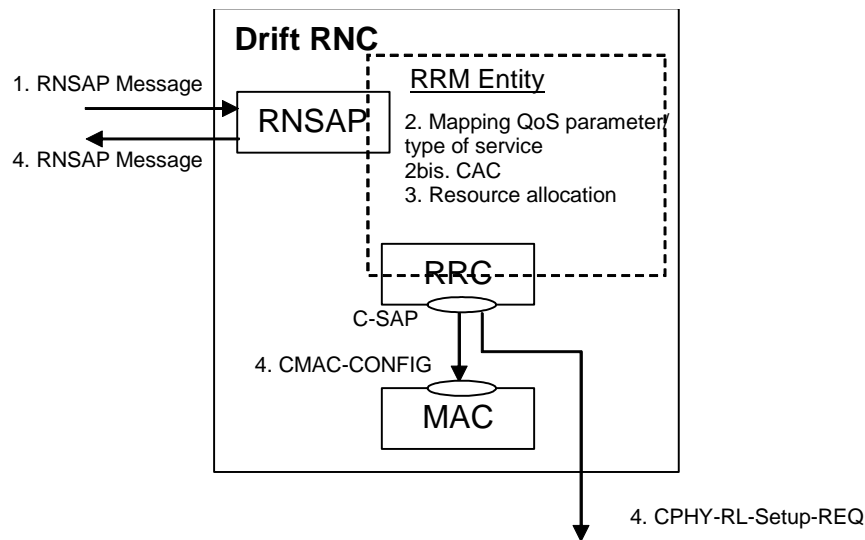

Figure 6-3: This model shows how standardised RNSAP and RRC layers are involved in the CAC process

1. SRNC requests DRNC for establishing a Radio Link. A RNSAP message contains the QoS parameters and the type of Common Transport Channel to be used.
2. According to QoS parameters the requested service is assigned a type of service. CAC is performed according to the type of service and to the type of Common Transport Channel requested by SRNC.
3. Resources are allocated according to the result of CAC.
4. Acknowledgement is sent back to the SRNC according to the result of CAC. L1 and MAC are configured accordingly by RRC layer.

7 Radio Bearer Control

7.1 Usage of Radio Bearer Control procedures

Radio Bearer (RB) Control procedures are used to control the UE and system resources [9]. This subclause explains how the system works with respect to these procedures and how e.g. traffic volume measurements and/or inactivity timers could trigger these procedures. In order to optimize the system resources and the UE battery consumption, UTRAN may use the traffic volume measurements and/or inactivity timers in Streaming, Interactive and Background traffic classes.

7.1.1 Examples of Radio Bearer Setup

In order to set up a new RB, a RRC connection must have been established, and some NAS negotiation has been performed. The RB Setup message comes from UTRAN and depending on the requirement of the service a common or a dedicated transport channel could be used. In the example below the UE is using a common transport channel for the RRC connection and stays on the common transport channel after the RB setup.

However, transport channel parameters such as transport formats and transport format combinations are configured not only for the used common transport channel, but also for dedicated transport channel for future use.

All physical parameters are the same before and after the RB setup in this example.

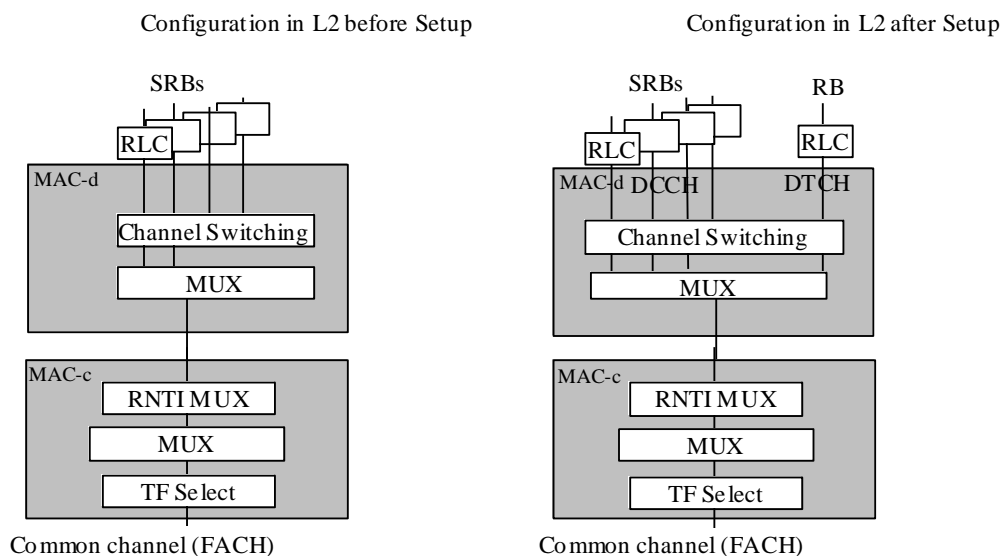

Figure 7-1: Configuration of L2 in the UTRAN DL before and after the RB setup

Detailed examples of messages exchange and parameters used are reported in Annex B, Subclause B.1.

7.1.2 Examples of Physical Channel Reconfiguration

This RRC procedure is used to reconfigure the Physical channel and can by that also trigger Transport channel type switching.

Below several examples of Physical Channel reconfigurations are shown, triggered by different amount of UL or DL data.

7.1.2.1 Increased UL data, with switch from CELL_FACH to CELL_DCH

A UE that is in CELL_FACH state can transmit a small amount of user data using the common transport channels. For larger amounts it is more appropriate to use a dedicated transport channel. Since each UE doesn't know the total load situation in the system, UTRAN decides if a UE should use common transport channels or a dedicated transport channel.

The monitoring of UL capacity need is handled by a UTRAN configured measurement in the UE. When the Transport Channel Traffic Volume (equivalent to the total sum of Buffer Occupancies of logical channels mapped onto the transport channel) in the UL increases over a certain threshold the UE sends a measurement report to UTRAN. This threshold to trigger the report is normally given in System Information, but UTRAN can also control the threshold in a UE dedicated Measurement Control message.

Since UTRAN has the current status of the total UL need, it can decide which UEs should be switched to a dedicated transport channel. If UTRAN has pre-configured in the UE the transport formats and transport format combinations to be used on the dedicated transport channel for the UE, a Physical channel reconfiguration procedure could be used to assign dedicated physical resources.

The spreading factor for the physical channels assigned then specifies the transport format combinations that are allowed to use.

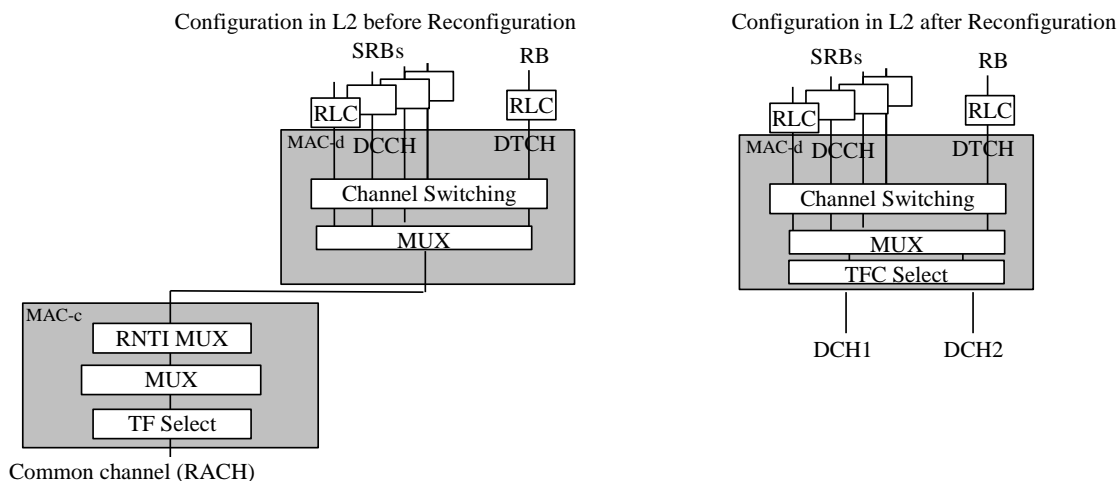

Figure 7-2: Configuration in the UTRAN UL before and after the Physical channel reconfiguration

Detailed examples of messages exchange and parameters used are reported in Annex B, Subclause B.2.1.

7.1.2.2 Increased DL data, no Transport channel type switching

If the Transport Channel Traffic Volume increases above a certain threshold in the network the UTRAN can do a physical channel reconfiguration. Here the UE uses a dedicated transport channel, and this procedure is used to decrease the spreading factor of the physical dedicated channel.

A variable bitrate service that has large traffic variations should have transport formats and transport format combinations defined for lower spreading factors than currently used on the physical channel. If this configuration already exists in the UE, the Physical Channel Reconfiguration is sufficient to increase the throughput for this user. However, if the transport formats and transport format combinations have not been previously defined to support a lower spreading factor, a Transport channel reconfiguration must be used instead in order to get any increased throughput.

In this example, only downlink physical parameters are changed since there is no need to increase the UL capacity.

Detailed examples of messages exchange and parameters used is reported in Annex B, Subclause B.2.2.

7.1.2.3 Decrease DL data, no Transport channel type switching

Since downlink channelisation codes are a scarce resource, a UE with a too high, allocated gross bit rate (low spreading factor) must be reconfigured and use a more appropriate channelisation code (with higher spreading factor). This could be triggered by a threshold for the Transport Channel Traffic Volume and some inactivity timer, i.e. that the Transport Channel Traffic Volume stays a certain time below this threshold.

After the physical channel has been reconfigured, some of the transport formats and transport format combinations that require a low SF can not be used. However, these are stored and could be used if the physical channel is reconfigured later to use a lower spreading factor.

Detailed examples of messages exchange and parameters used is reported in Annex B, Subclause B.2.3.

7.1.2.4 Decreased UL data, with switch from CELL_DCH to CELL_FACH

In the network the UE traffic can be evaluated and the network can observe which transport format combinations that are used in the UL. The network could also simply look at how much data the UE transmits or use measurement reports.

If the UE is transmitting a low amount of data in the uplink and there is little traffic in the downlink, this could trigger a switch from a dedicated transport channel to a common transport channel. Depending on if the already defined RACH/FACH configuration is possible/preferred in the cell that the UE will be in after the switch, a Transport channel reconfiguration or a Physical channel reconfiguration procedure is used.

In the example below the UE is in a cell with a configuration for common channel similar to the one on the dedicated transport channel. Therefore, the Physical channel reconfiguration procedure can be used.

After the UE has performed the transport channel type switch to the CELL_FACH state, all transport channel parameters such as transport formats for the dedicated transport channel are stored. The same configuration of the dedicated transport channels could then be reused if the UE switches back to the CELL_DCH state.

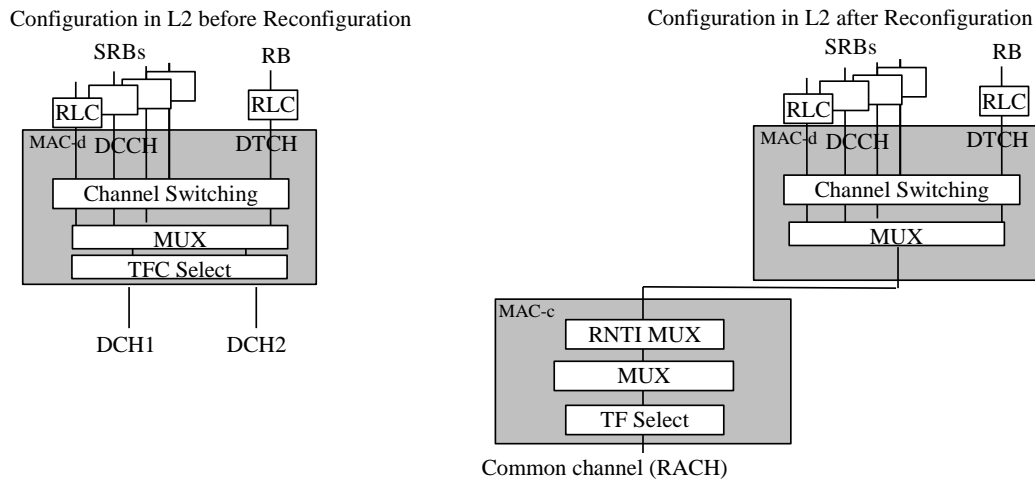

Figure 7-3: Configuration in the UTRAN UL before and after the Physical channel reconfiguration

Detailed examples of messages exchange and parameters used is reported in Annex B, Subclause B.2.4.

7.1.3 Examples of Transport Channel Reconfiguration

This RRC procedure is used to reconfigure the transport channel and the physical channels, and can by that also trigger Transport channel type switching.

Below, several examples of Transport channel reconfiguration are shown, triggered by different amount of UL or DL data.

7.1.3.1 Increased UL data, with no transport channel type switching

When a UE Transport Channel Traffic Volume increases above a certain threshold, a measurement report is sent to UTRAN. Depending on the overall load situation in the network the UTRAN could decide to increase the uplink capacity for a UE. Since every UE has its "own" code tree, there is no shortage of UL codes with a low spreading factor, and all UEs can have a low spreading factor code allocated.

Therefore, instead of channelisation code assignment as used in the DL, load control in the UL is handled by the allowed transport formats and transport format combinations for each UE. To increase the throughput for a UE in the uplink, UTRAN could send a Transport channel reconfiguration or a TFC Control message.

Here a Transport channel reconfiguration is used. Although, the TFC Control procedure is believed to require less signalling, it can only restrict or remove restrictions of the assigned transport format combinations and that may not always be enough. If a reconfiguration of the actual transport formats or transport format combinations is required, the Transport channel reconfiguration procedure must be used instead.

To make use of the new transport format combinations the physical channel must also be reconfigured to allow a lower spreading factor.

Detailed examples of messages exchange and parameters used is reported in Annex B, Subclause B.3.1.

7.1.4 Examples of Radio Bearer Reconfiguration

A RB reconfiguration is here used to change how the MUX in MAC of logical channels belonging to different RBs is configured.

The RB Reconfiguration message includes parameters for the new multiplexing configuration in MAC, and a reconfiguration of the Transport channel that both RBs will use. The old obsolete transport channel is also removed (here DCH3 is removed). All other parameters associated with the RBs are unchanged.

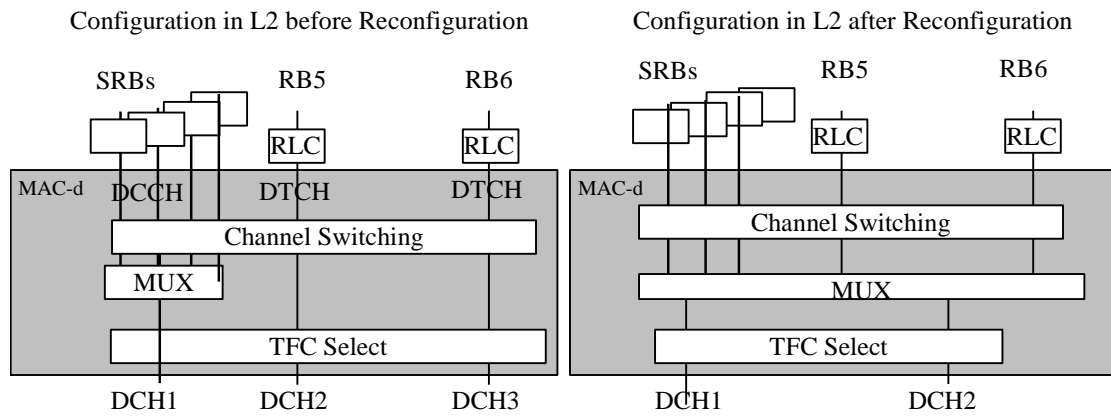

Figure 7-5: Configuration in the UTRAN DL before and after the RB reconfiguration

Detailed examples of messages exchange and parameters used is reported in Annex B, Subclause B.4.

8 Dynamic Resource Allocation

8.1 Code Allocation Strategies for FDD mode

8.1.1 Introduction

Code allocation deals with the problem how different codes are allocated to different connections. The channelisation codes used for spreading are Orthogonal Variable Spreading Factor (OVSF) codes that preserve the orthogonality between physical channels. The OVSF code is shown in the following figure:

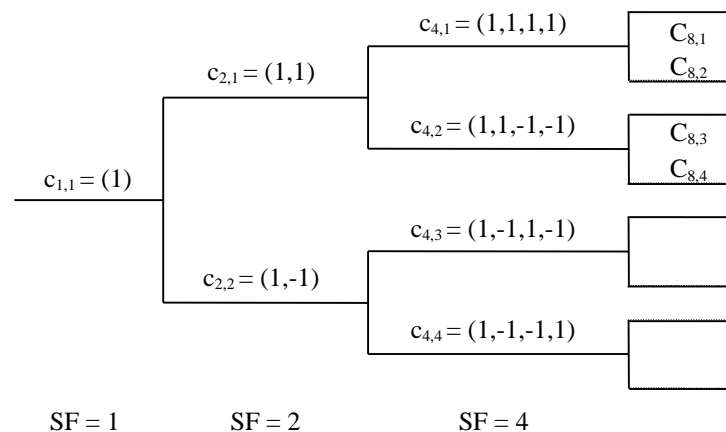

Figure 8-1: OVSF Code Tree

Each level in the code tree is described as $C_{SF,code\ number}$, where the spreading factor (SF) is ranging from 4 to 512 (downlink) or from 4 to 256 (uplink) for the chip rate of 3.84 Mcps. In the downlink a channelisation code can be assigned to a UE if and only if no other code on the path from the specific code to the root of the tree or in the sub-tree below the specific code is assigned. For example, a random assignment of large-SF codes to low data rate channels may preclude a large number of small-SF codes. It inefficiently limits the number of remaining codes that could be used by other users. On the contrary, it will be advantageous to assign codes to low data rate users in such a way as to minimise the number of unavailable small-SF codes. Moreover, it is expected to be advantageous to assign users operative at a particular data rate to closely related codes so as to minimise the number of small-SF codes being marked as unavailable. A proper code allocation algorithm is used to find the "closely related code" to prevent the BS from running out of codes and to utilise the system resource effectively. The so-called "closely related code" would be obtained via a code allocation strategy according to the available codes of the BS and the capability of the UE.

8.1.2 Criteria for Code Allocation

OVSF codes are valuable resources in CDMA system. The objective of the code allocation is to support as many users as possible with minimum complexity.

In the uplink the transmissions of UEs are separated by their scrambling codes and the channel codes that are to be used in particular circumstances with dedicated channels is defined [22].

In the application, different UEs may request for different types of services with different transmission rates. Each UE may have the capability to use more than one code to support different data rates.

The following criteria can be envisaged:

1. **Utilisation.** The utilisation is defined as the ratio of assigned bandwidth and overall bandwidth. A code allocation scheme that preserves more small-SF codes has a higher chance to provide a higher utilisation. For example, $C_{4,1}$ and $(C_{8,1}, C_{8,3})$ are the available codes of a BS resulting from two different code allocation schemes. $C_{4,1}$ (which is equivalent to codes $C_{8,1}$ and $C_{8,2}$) can support a symbol rate up to 960 kbps. $(C_{8,1}, C_{8,3})$ can also support the same symbol rate as $C_{4,1}$ does. However, only $C_{4,1}$ can support the UE that requests for 960 kbps symbol rate

using only one code (due to the capability of the handset). In this example, the former has more small-SF codes than the latter, thus, it will result in a better utilisation.

2. Complexity. The more codes are used, the complexity of the system will be increased. In some cases, there are more than one way to meet the first criterion mentioned above. For example, one UE can use either one code ($C_{4,1}$) or two codes ($C_{8,1}$ and $C_{8,2}$) as the channelisation codes. Under this situation, the code allocation scheme that requires the least codes should be chosen.

8.1.3 Example of code Allocation Strategies

An example of code allocation algorithm based on the two above criteria is presented in the following. In order to indicate the available OVFS codes of the system, an order pair C , called a code-word, is introduced. Let $C=(a_1,a_2,a_3,a_4,a_5,a_6,a_7)$ denote the available codes for SF=(4,8,16,32,64,128,256), respectively, where $a_1 \leq 4$, $a_2 \leq 8$, $a_3 \leq 16$, $a_4 \leq 32$, $a_5 \leq 64$, $a_6 \leq 128$, and $a_7 \leq 256$. The total data rate (*i.e.* it has been normalised by a data rate of an OVFS code with SF=256) supported by C is called the weight W and can be obtained by:

$$W(C) = a_1 \cdot 2^6 + a_2 \cdot 2^5 + a_3 \cdot 2^4 + a_4 \cdot 2^3 + a_5 \cdot 2^2 + a_6 \cdot 2^1 + a_7.$$

$S(n)$ is a set of code-words that can support a total data rate up to n and it can be obtained by:

$$S(n) = \{C | W(C) = n, \forall C\}.$$

The number of codes $N(C)$ required for transmitting a code-word C can be calculated by:

$$N(C) = a_1 + a_2 + a_3 + a_4 + a_5 + a_6 + a_7.$$

Consider a UE which requests for a data rate of n . Define $C_t=(a_1,a_2,a_3,a_4,a_5,a_6,a_7)$ and $C_r=(a_1',a_2',a_3',a_4',a_5',a_6',a_7')$ are the code-words of the system before and after code allocation, respectively. For $W(C_t)=m$, we can find that $W(C_r)=W(C_t)-n=m-n$.

For example, $m=13$ and $n=6$ $C_t=(0,0,0,0,2,1,3)$.

The possible candidates for the allocated codes is one of the element of set $S(6)$, where:

$$S(6) = \{(0,0,0,0,0,0,6), (0,0,0,0,0,1,4), (0,0,0,0,0,2,2), (0,0,0,0,1,0,2), (0,0,0,0,0,3,0), (0,0,0,0,1,1,0)\} \\ = \{C1, C2, C3, C4, C5, C6\}.$$

Thus, the possible code-words of the system after allocating the codes to the UE can be obtained by

$$T(7) = \{C_t - C1, C_t - C2, C_t - C3, C_t - C4, C_t - C5, C_t - C6\} \\ = \{(0,0,0,0,1,1,1), (0,0,0,0,1,1,1), (0,0,0,0,1,1,1), (0,0,0,0,1,1,1), (0,0,0,0,1,0,3), (0,0,0,0,1,0,3)\}.$$

According to the first criterion, (0,0,0,0,1,1,1) is the preferred code-word (denoted as C_{opt}) after the allocation and $C1$, $C2$, $C3$, and $C4$ are possible candidates for the allocated code-words. The number of codes required for these code-words are $N(C1)=6$, $N(C2)=5$, $N(C3)=4$, and $N(C4)=3$. According to the second criterion, $C4$ would be chosen because it uses the least codes.

In general, it is not feasible to examine all of the possible code-words from the set $S(n)$ as illustrated above, especially for a large value of n . It is also a time-consuming process to find $T(m-n)$ by subtraction of the code-words individually. Here, a fast code allocation algorithm can be used to find the preferred code-word C_{opt} , where:

$$C_{opt} = C_t - (C_t - (0,0,0,0,0,0,n)).$$

In the above example, $C_t=(0,0,0,0,2,1,3)$, $n=6$, and $C_t - (0,0,0,0,0,0,6)=(0,0,0,0,1,1,1)$. Therefore, $C_{opt}=(0,0,0,0,2,1,3) - (0,0,0,0,1,1,1) = (0,0,0,0,1,0,2) = C4$.

In a particular implementation of the code allocation algorithm, the RNC could maintain a list of available codes. When UE requests for channel codes, the number of codes of different SF required supporting the required data rate could be identified by the code allocation algorithm. Upon identification of codes of suitable SFs, the BS will assign the codes from the table.

In the real system, the UE can use only k codes for transmitting data. In some cases, the fast code allocation algorithm cannot be applied. Therefore, two situations may occur:

Situation I. $N(C_{opt}) \leq k$:

- The procedure described above can be used and the allocated code-word $C = C_{opt}$.

Situation II. $N(C_{opt}) > k$:

- In this situation, the fast code allocation algorithm may not be applied because the MS can not support as many codes as that determined by C_{opt} . In this case, the allocated code-word C is the one that $N(C)=k$. However, the new call requests will be blocked if the MS can not support the requested data rate with the given number of codes k .

8.1.4 Void

8.2 DCA (TDD)

The purpose of DCA is on one side the limitation of the interference (keeping required QoS) and on the other side to maximise the system capacity due to minimising reuse distance.

In order to save battery life time, a UE in idle mode does not perform and report measurements for DCA. ISCP measurements can be started at call establishment. UETS ISCP measurements are reportable in CELL_DCH state and limited to the current serving cell also in CELL_FACH state.

The channel allocation algorithm will be a distributed, interference adapted approach implemented on network side in the RNC base on local signal strength measurements performed in the UE and the Node B. A priori knowledge about other used channels in the vicinity can be implicitly used without additional signalling traffic.

8.2.1 Channel Allocation

For the UTRA-TDD mode a physical channel is characterised by a combination of its carrier frequency, time slot, and spreading code as explained in the clause on the physical channel structure.

Channel allocation covers both:

- resource allocation to cells (slow DCA);
- resource allocation to bearer services (fast DCA).

8.2.1.1 Resource allocation to cells (slow DCA)

Channel allocation to cells follows the rules below:

- A reuse one cluster is used in the frequency domain is normal for 3.84 Mcps TDD and can be used for 1.28 Mcps TDD. In terms of an interference-free DCA strategy a timeslot-to-cell assignment is performed, resulting in a time slot clustering. A reuse one cluster in frequency domain does not need frequency planning. If there is more than one carrier available for a single operator also other frequency reuse patterns >1 are possible.
- Any specific time slot within the TDD frame is available either for uplink or downlink transmission. UL/DL resources allocation is thus able to adapt itself to time varying asymmetric traffic. For 1.28 Mcps TDD there can be only two switching points between uplink and downlink slots within a frame.
- In order to accommodate the traffic load in the various cells the assignment of the timeslots (both UL and DL) to the cells is dynamically (on a coarse time scale) rearranged (slow DCA) taking into account that strongly interfering cells use different timeslots. Thus resources allocated to adjacent cells may also overlap depending on the interference situation.
- Due to idle periods between successive received and transmitted bursts, UEs can provide the network with interference measurements in time slots different from the one currently used. The availability of such information enables the operator to implement the DCA algorithm suited to the network.
- For instance, the prioritised assignment of time slots based on interference measurements results in a clustering in the time domain and in parallel takes into account the demands on locally different traffic loads within the network.

8.2.1.2 Resource allocation to bearer services (fast DCA)

Fast channel allocation refers to the allocation of one or multiple physical channels to any bearer service. Physical resources are acquired (and released) according to a cell-related preference list derived from the slow DCA scheme.

1. The following principles hold for fast channel allocation: The basic physical resource used for channel allocation is one code / timeslot / (frequency).
2. Some bearers are assigned more than one physical resource. This can be made both in the code domain (pooling of multiple codes within one timeslot = multicode operation) and time domain (pooling of multiple timeslots within one frame = multislot operation). Additionally, any combination of both is possible. Simulation results reported in Appendix A, recommend that the DCA prefers code pooling, over time slot pooling, for UDD packet data; the use of code pooling in fact results in lower number of unsatisfied users.
3. Since the maximal number of codes per time slot in UL/DL depends on several physical circumstances like, channel characteristics, environments, etc. (see description of physical layer) and whether additional techniques to further enhance capacity are applied (for example smart antennas), the DCA algorithm has to be independent of this number.
 4. Channel allocation differentiates between dedicated channel (DPCH) and shared channel (USCH/DSCH) bearer services:
 - Dedicated services: Channels remain allocated for the whole duration the bearer service is established. The allocated resources may change because of a channel reallocation procedure (e.g. VBR).
 - Shared channel services: Channels are allocated for the period of the transmission of a quantity of data only. UDD channel allocation is performed using 'best effort strategy', i.e. resources available for shared channel services are shared between all UEs that are admitted to shared channel services with pending transmission requests. The number of physical resources allocated for any shared channel service is variable and depends at least on the number of current available resources and the number of shared channel services attempting for packet transmission simultaneously.
5. Channel reallocation procedures (intra-cell handover) can be triggered for many reasons:
 - To cope with varying interference conditions.
 - In the case of high rate dedicated services (i.e. services requiring multiple physical resources) a 'channel reshuffling procedure' can be used to prevent a fragmentation of the allocated codes over too many timeslots. This is achieved by freeing the least loaded timeslots (timeslots with minimum used codes) by performing a channel reallocation procedure.
 - When using smart antennas, channel reallocation is useful to keep spatially separated the different users in the same timeslot.

8.2.2 Measurements Reports from UE to the UTRAN

While in active mode the DCA needs measurements for the reshuffling procedure (intra-cell handover). The specification of the measurements to be performed is contained in [5]. In this subclause the relevant measurement reports are presented:

- Pathloss of a sub-set of cells .
- Inter-cell interference measurements of all DL time slots requested by the UTRAN .
- Primary CCPCH RSCP (Received signal code power).
- Transport channel BLER.
- Transmission power of the UE on the serving link.
- Signal to interference ratio.
- UTRA and GSM carrier RSSI.

9 Power Management

9.1 Variable Rate Transmission

9.1.1 Examples of Downlink Power Management

When an RB connection with variable rate transmission is established, the RRC considers the down-link traffic conditions, then assigns the TFCS to MAC and allowable transmission power to L1. The allowable transmission power can be determined according to the service requirements and the traffic conditions, and is updated for each user when the traffic conditions change. RRC also assigns a measurement to Node B that sets the allowable transmission power to the transmitted code power.

During a call, the physical layer averages the transmission power for that UE over one or several frames. If the averaged transmission power for the UE becomes higher than the allowable transmission power, that is, the channel conditions are bad, L1 indicates to MAC that the "Allowable transmission power has been reached". The MAC in response reduces the data rate within TFCS, and the power control procedure then reduces the total transmission power for that UE and excess interference to other UEs is avoided. The PDUs that can not be transmitted in a TTI shall be buffered according to the discard function set by RRC.

When channel conditions improve and the averaged transmission power falls [margin] dB below than the allowable transmission power the physical layer indicates to MAC that the "Average transmission power is below allowable transmission power by margin dB" (the values for [margin] are chosen to match the power requirements of different increments for the transport channels within the TFCS). If there is enough data to be sent the MAC in response increases the data rate by increasing the number of transport blocks delivered to L1 and the physical layer increases the total transmission power to the UE by the predefined amount. This allows data that was buffered during bad channel conditions to be delivered to the UE.

Simulation results on down-link variable rate packet transmission are provided in Appendix E.

9.1.2 Examples of Uplink Power Management

When an RB connection with variable rate transmission is established, the RRC assigns the TFCS and the allowable transmission power to the UE. The maximum allowed UE transmitter power is defined in [9].

During a call, the physical layer averages the transmission power over one or several frames. If the UE output power measured over at least [t1] ms is [margin1] dB within the maximum, the UE shall adapt the transport format combination corresponding to the next lower bit-rate. The PDUs that can not be transmitted in a TTI shall be buffered according to the discard function set by RRC.

When channel conditions improve and the averaged transmission power falls [margin] dB below than the allowable transmission power (the values for [margin] are chosen to match the power requirements of different increments in the number of transport channels within the TFCS) and there is enough data to be sent the UE shall continuously estimate whether the output power needed for a switch to the transport format combination corresponding to the next higher bit-rate does not exceed [margin] dB below the maximum. If the UE has enough power to support that up-switch for at least [t2] ms the UE shall increase the data rate by increasing the number of transport blocks delivered to L1 and the physical layer increases the total transmission power by the predefined amount. This allows data that was buffered during bad channel conditions to be transmitted to Node B.

UE transport format selection shall be done according to [18] considering logical channel priorities. If the bit rate of a logical channel carrying data from a codec supporting variable rate operation is impacted by the transport format combination selection, the codec data rate shall be adopted accordingly.

Minimum requirements for t1, t2 (multiple of 10ms) and margin as well as maximum delay requirements for a transport format combination switch are defined in [16].

9.2 Void

9.3 Examples of balancing Downlink power

9.3.1 Adjustment loop

Adjustment loop is a method for balancing downlink power among active set cells during soft handover. For adjustment loop, DL reference power P_{REF} and DL power convergence coefficient r ($0 < r < 1$) are set in the active set cells during soft handover so that the two parameters are common to the cells. For simplicity, DL powers of two cells are considered in this explanation. Adjustment loop works in addition to inner loop power control, and DL power at slot i of two cells, $P_1(i)$, and $P_2(i)$, are updated at a certain interval (typically in every slot as in this explanation) as follows:

$$P_1(i+1) = P_1(i) + (1-r)(P_{REF} - P_1(i)) + S_{INNERLOOP1}(i)$$

$$P_2(i+1) = P_2(i) + (1-r)(P_{REF} - P_2(i)) + S_{INNERLOOP2}(i)$$

where $S_{INNERLOOP1}(i)$ is the result of the inner loop power control.

The difference is derived from the two equations above if TPC error does not occur i.e. $S_{INNERLOOP1}(i)$ and $S_{INNERLOOP2}(i)$ are equal:

$$P_1(i+1) - P_2(i+1) = r(P_1(i) - P_2(i)) = r^i(P_1(1) - P_2(1))$$

Therefore the difference converges at zero when r is smaller than one. Simulation results are available in Appendix F.

10 Radio Link Surveillance

10.1 Mode Control strategies for TX diversity

10.1.1 TX diversity modes

TX diversity modes can be classified into two categories:

- Open loop modes
- Closed loop modes

In open loop mode no feedback information from the UE to the node B is transmitted in order to control how the signal is transmitted from the diversity antennas. This is in contrast to closed loop operation where UE sends feedback information to the Node B in order to optimise the transmission from the diversity antennas.

For a detailed description of TX diversity techniques in both FDD and TDD mode, refer to [L1 Spec].

10.1.2 Mode Control Strategies

10.1.2.1 DPCH

What mode will be used on DPCH and when is controlled by UTRAN. Important criteria for the mode control are the radio channel conditions. This is because depending on the radio channel different modes will provide the best performance.

Regarding the downlink performance there are two important factors that should be considered when doing mode control:

- Maximum Doppler frequency (i.e., speed of the UE).
- Number of multipath components.

Basically the UE could measure both of these and report back to UTRAN. As it happens both of these could be measured by UTRAN as well. Therefore, there is no need to signal this information from UE.

The use of TX diversity on dedicated channels is signalled to the UE in call set-up phase.

10.1.2.2 Common channels

Only open loop can be used for PCCPCH, SCCPCH, and AICH. For common channels the UE gets information about the use of TX diversity through system information broadcast on BCCH. Each of the different common channels above can utilise TX diversity irrespective of it is used on any of the other common channels.

11 Codec mode control

11.1 AMR mode control

The AMR speech codec consists of the multi-rate speech codec with eight source rates from 4.75 kbit/s to 12.2 kbit/s [12]. The change between the AMR specified rates could occur in the WCDMA in downlink, when traffic on the air interface exceeds the acceptable load, or when the connection based FER value indicates the bad quality of the connection. In uplink the corresponding change can be made when there is need to extend the uplink coverage area for speech by using several AMR modes or when the measured load on the air interface is reported to exceed the acceptable level.

In principle the speech coder is capable of switching its bit rate every 20 ms speech frame upon command. [12] However in practice the AMR mode adaptation is needed less frequently.

In WCDMA the network architecture has been defined to consist of two different network domains; UTRAN and Core Network (CN). Due to this definition and decisions about the location of the Transcoder, the AMR related functions are forced to divide between the previously mentioned network domains.

The location of the Transcoder in WCDMA was defined to be in the core network domain, and logically outside the Access Stratum. Thus also the location of the AMR speech codec is into the Core Network as well.

From the data transfer point of view the defined location of the encoder in the NW side means that at least all AMR coded data is going to be transmitted not only via Iub and air interface but also via Iu –interface (see Figure 11-1).

The functionality of the codec mode control on the contrary can not locate in the Transcoder, because this control entity needs information from the air interface to make decision about the valid AMR modes for the AMR related connections. Thus the only domain, which can provide this kind of information from the air interface to AMR codec mode control entity, is UTRAN. In GSM the control of the codec mode is provided by the BTS, but in WCDMA this solution is not applicable due to soft handover procedure defined for the dedicated traffic channels. Thus the AMR mode control function should be a part of the RNC functionality. The control of the AMR mode is part of the RRM strategies, due to its implications on reserving and controlling resources from the air interface.

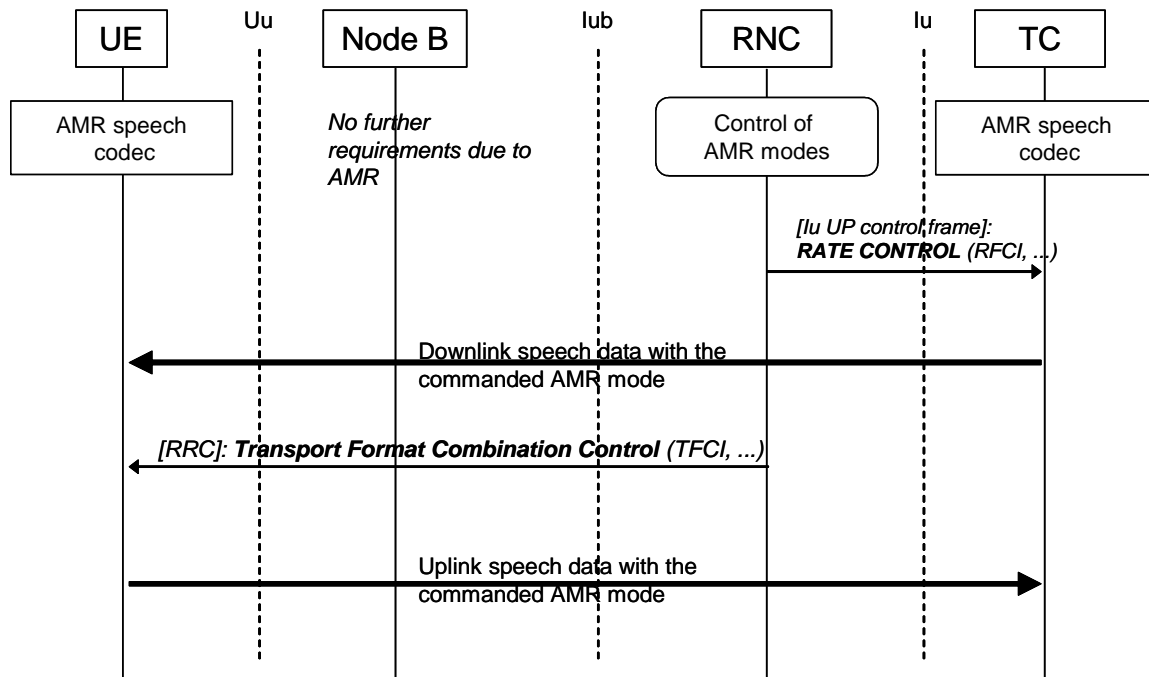

Figure 11-1

In the WCDMA the AMR mode adaptation is carried out with the aid of AMR mode control function, which is responsible for detecting the need of the AMR mode adaptation and to initiate required procedures to change the current AMR mode to the newly selected AMR mode. The AMR mode change request can be made with the aid of the AMR mode commands, which are sent from the RNC either to the Transcoder for downlink data transfer or to the UE for uplink data transfer. In principle the supported AMR mode adaptation can be asymmetric, which implies the possibility to use different AMR modes in uplink and downlink during active speech call.

Therefore, the role of the RRM during the AMR coded speech call will be basically the role of the supervisor of the connection.

The AMR mode command is used to change the current AMR mode to the new one, which suits better to the conditions on the air interface.

The initialisation of AMR mode command will be based on load information, which has been received from the air interface. The following table shows the required information during the AMR mode adaptation in WCDMA:

Information used in AMR control	Load
Downlink information	BS reports total BS transmission power
Uplink information	BS measures total interference level

When RRM indicates the need for the AMR mode adaptation in one direction, the command is sent from the UTRAN to the appropriate AMR codec. If the AMR mode is intended to be used in downlink, the command is sent to the encoder inside the Transcoder via Iu –interface, whereas AMR mode needed on uplink is sent to the UE through air interface.

For the uplink, the AMR mode command from RNC to UE is realised as outband, through RRC Transport Format Combination Control message containing the allowed TFCI. [9]

If the code rate is switched every 20 ms speech frame, in order to fulfil the time constraint a compact version of the RRC message is sent on the RLC-TM signalling radio bearer. This functionality is for Release-4.

For the downlink, the AMR mode command from RNC to TC is realised as inband, through the RATE CONTROL Iu-UP control frame. The permitted rate is given as RFCI indicators [23]. Transport format for the transport channel carrying the different classes of AMR source codec provides an unambiguous mapping of the codec mode that is used.

12 Congestion Control

12.1 Introduction

In CDMA networks, congestion control mechanisms should be devised to face situations in which the system has reached a congestion status and therefore the QoS guarantees are at risk due to the evolution of system dynamics.

12.2 Example of Congestion Control procedures

When a congestion state is present it has to invoke a congestion control procedure, that can include:

1. Congestion detection: A criterion based on the increase of a load factor over a certain threshold during a certain amount of time can be introduced to decide whether the network is congested or not.
2. Congestion resolution. An algorithm based on the following three steps could be used in order to maintain the network stability:
 - Prioritisation: Ordering the different users from lower to higher priority (e.g., from those that expect a lower grade of service to those with more stringent QoS requirements).
 - Load reduction: Two main actions could be taken:
 - a. Selective blocking of new connections while in congestion
 - b. Reducing the maximum transmission rate
 - Load check: Load reduction actions can be carried on until the considered load factor is below a given threshold for a certain amount of time (i.e., the system can enter the congestion recovery status).
3. Congestion recovery: It is possible to attempt to restore the transmission parameters used before the congestion was triggered, by using a “time scheduling” on a user by user basis.

13 High Speed Downlink Packet Access

The examples in this clause apply from the Rel-5 onwards.

13.1 HSDPA scheduling

13.1.1 Introduction

The Radio Resource Management (RRM) strategies for HSDPA foresees that packet scheduling functionality performed by MAC-hs is tight-coupled with Adaptive Modulation and Coding (AMC) to the radio channel conditions and the Hybrid Automated ReQuest (HARQ) mechanism.

AMC matches the modulation-coding scheme to the instantaneous channel conditions for each user transmission. The power of the transmitted signal is held constant over a subframe interval, and the modulation and coding format are selected according to the quality of the received signal or the channel conditions, reported by the UE in the previous subframes. In this scenario, users close to the base station are typically assigned higher-order modulation schemes with higher code rates. The modulation-order and code rate will decrease as the distance from the base station increases.

The packet scheduling functionality acts in cooperation with the HARQ scheme in order to be able to recover temporary occurrence of bad radio conditions. HARQ combines feed-forward error correction (FEC) and ARQ methods that use packets from previous failed attempts for subsequent decoding. HARQ is an implicit link-adaptation technique and - unlike AMC - it uses link-layer acknowledgments (ACK/NAACK) for re-transmission decisions. As a result, AMC provides the coarse data-rate selection upon estimated radio conditions, while HARQ provides fine data-rate adjustment based on channel conditions.

Along with AMC and HARQ, an efficient packet scheduling algorithm is an essential technique in order to improve the total system throughput as well as the peak throughput of each user. In the following subclauses, possible scheduling strategies are discussed and analysed.

13.1.2 Scheduling strategies

In general terms, the HSDPA packet scheduler entity can be considered responsible for the following two main issues:

- maximization of the air interface performance (i.e. sector throughput).
- to fulfil the QoS requirement in downlink for each user.

Since packet scheduling strategies should take into account also the QoS constraints, different approaches can be envisaged according to the type of service. For example, different strategies can be assumed for services belonging to INTERACTIVE or BACKGROUND classes (i.e. non-real-time services) and for the services belonging to CONVERSATIONAL and STREAMING classes (i.e. real-time services).

13.1.2.1 Non real-time services

HSDPA packet scheduler functionality for non real-time services can be based exclusively on the air interface performance maximization, since it is not necessary to guarantee a minimum bandwidth to this type of services (i.e. the “guaranteed bit rate” parameter in the RAB profile is not applicable to non real-time services [24]).

Suitable packet schedulers for these services can be the Round Robin (RR) scheme and Maximum C/I scheme. In the Maximum C/I scheme, the scheduler assigns resources to the user with the highest received signal-to-interference power ratio (SIR), according to the reported received SIR value from all the users. Thus, an efficient modulation and channel coding scheme (MCS) yielding a higher bit rate is employed with priority for the user, to which the Maximum C/I method assigns the packet. Therefore, the Maximum C/I scheduler provides maximum system capacity (i.e. maximum sector throughput) at the expense of fairness, because all frames can be allocated to a single user with the best channel conditions and users experiencing poor radio conditions are further restricted in accessing the radio resources. As an alternative, in the RR packet scheduling the packet transmission resources are equally assigned to all users within a sector irrespective of the radio link conditions, so this scheduler provides a fair sharing of resources at the expense of a lower system capacity.

In addition to RR and Maximum C/I schemes, also other packet schedulers can be envisaged for non real-time users. For instance, the Proportional Fairness (PF) method assigns packet transmission based on criteria such as the instantaneous SIR or long-term averaged SIR value of each user. Thus, after maintaining the fairness of the packet assignment duration for each user, packet assignment based on the priority is possible starting from the user having a relative higher received SIR. Simulation results in [26] show that although the Maximum C/I scheme method achieves an aggregated user throughput within a cell higher than that using the PF and RR methods, the PF method enhances the user throughput for a large number of access users with a lower received SIR compared to the Maximum C/I method.

13.1.2.2 Real time / near real-time services

When real-time or near real-time services are considered, the RRM scheme should ensure throughput optimisation over the UMTS air interface and, at the same time, fulfil QoS requirements in order to satisfy every user (in terms of guaranteed bandwidth, maximum delay, etc.).

QoS parameters for MAC-hs packet scheduler

In order to take into account QoS constraints associated to real-time services, MAC-hs packet scheduler at Node B can take advantages of the following two parameters:

- MAC-hs Guaranteed Bit Rate.
- Discard Timer.

These parameters can be included in the HS-DSCH Information IE present in the RADIO LINK REQUEST message and sent from RNC to the Node B [27] hence the scheduler in Node B may use this information to optimise MAC-hs scheduling decisions.

Examples of scheduling for real time services

Different examples of HSDPA packet scheduling algorithms, in conjunction with AMC and HARQ mechanisms, can be considered, in order to clarify how it could be possible to take advantage of the QoS parameters mentioned above when real-time services are considered.

The support of quality of service can be achieved by schedulers by prioritizing packets taking into account, for instance single packet delay, average delay of packets in queue of each user, or queue size. However, in order to optimise the system capacity, e.g. cell throughput, this prioritisation could be determined also taking into account parameters reflecting radio conditions.

This objective can be achieved, for example, by identifying a priority function where the above mentioned parameters affecting both QoS and system capacity are properly weighted. Possible examples of priority functions and related parameters are reported in Annex J.

14 Multimedia Broadcast Multicast Service (MBMS)

14.1 Introduction

The Multimedia Broadcast/Multicast Service (MBMS) introduced in Release 6 provides to the 3GPP Systems (UTRAN and GERAN) the capability for efficient packet data transmission of multimedia content (text, audio, picture, video, etc) from a single source entity to multiple endpoints. Transmitting the same data to multiple recipients allows network resources to be shared, then MBMS architecture enables the efficient usage of both radio-network and core-network resources, with an emphasis on radio interface efficiency.

14.2 MBMS in UTRAN

14.2.1 Mapping of MBMS bearer to p-t-p and p-t-m channels

The introduction of the Multimedia Broadcast Multicast Service in UTRA [31] has required enhanced techniques for optimised transmission of MBMS bearer service such as point-to-multipoint transmission, selective combining and transmission mode selection between point-to-multipoint and point-to-point bearer.

The p-t-m transmission was introduced in order to optimize UTRAN radio resources when several users are interested in the same service. In the case of p-t-m transmission, the UTRAN logical channel used for the MBMS user plane bearer is MTCH: it is mapped on a FACH transport channel and transmitted over the S-CCPCH physical channel.

The characteristics of S-CCPCH channel make more difficult the effective exploitation of the techniques used by UTRAN to optimize p-t-p radio links (e.g. radio link adaptation, fast power control, and Hybrid ARQ). For this reason, in order to improve the transmission efficiency over S-CCPCH, focusing on the performance at the cell edge, new functionalities were introduced in Release 6, such as selective combining and soft combining. In case of selective combining, the UE can receive and decode the p-t-m MBMS content simultaneously from radio links from different cells, selecting valid data on a transport block basis at the RLC layer. In case of soft combining, the UE receiver combines the signal from multiple cells at the Physical Layer.

Performance of S-CCPCH for MBMS in different scenarios can be found in [32]. The radio resources necessary for the transmission over S-CCPCH depend on the MBMS service bit rate, the QoS level to guarantee (in terms of BLER) and the link level radio bearer configuration (in particular the TTI). Due to the lack of fast power control mechanism, the resource consumption is evaluated in terms of E_c/I_{or} , representing the fraction of cell transmit power necessary to achieve the target BLER, in a given percentage of cell area and with respect to the interference conditions (geometric factor G). As an example, in order to achieve 95% of the cell coverage in the system scenarios considered for the evaluation, respecting a BLER target value of 1% for a 64kbit/s MBMS service, it is required to allocate to S-CCPCH a transmission power ranging from about 20% to -60% of the total base station downlink power, depending on the channel model taken into account, the TTI length and the number of radio-links available for the recombination combining [32].

In addition to the p-t-m transmission, the mapping of MTCH over traditional p-t-p channels has been kept for MBMS. In fact, if the number of users in the cell interested in a given service is low, the usage of many physical channels like PDCH or HS-PDSCH, relying on fast link adaptation (power control or Hybrid ARQ with AMC), could have the same efficiency than one S-CCPCH, also depending on the location of the users within the cell. In fact, every p-t-p connection requires only the necessary power (dynamically set by the link adaptation mechanisms) whereas the maximum transmission power of the S-CCPCH should be fixed a priori and it could be wasted if the trade off between this channels is not properly set.

For this reason the UTRAN may implement specific RRM strategies in order to dynamically select cell by cell the transmission mode that better exploits the available radio resources for MBMS.

14.2.2 MBMS counting

In order to identify the optimum transmission mechanism for the MBMS multi-cast service at every given time, UTRAN needs to determine the number of users within a cell interested in a MBMS service.

The need for counting is indicated by the CRNC by means of a notification message to UEs belonging to the same MBMS service group. The UEs respond to counting by sending dedicated RRC signalling to CRNC. The CRNC may use notification to indicate counting right before the MBMS session start or during an ongoing MBMS session (re-counting). In this way, a RRM decision algorithm can also command a switching between p-t-p or p-t-m connections with respect to changes that occur during the MBMS session (e.g. users enter or leave the cell or activate/de-activate the service).

The counting response triggers RRC signalling and it is desirable to avoid that a large number of UEs in a specific cell respond to counting at the same time (RACH congestion, etc). Therefore, UTRAN may also control the load due to the RRC signalling, by setting an access "probability factor".

It is worthwhile noting that the purpose of the counting procedure is not to determine the exact number of UEs in the cell, but to derive whether there is at least / at most a given number of UEs so that it is better to switch the transport channel type. Moreover, due to limited capability, a UE that activated a given service and that has replied to counting, may not be able to receive that service in p-t-m, in case other services at higher priority are being transmitted simultaneously. In this case the counting procedure overestimates the number of UEs that actually receive the service. Hence, the exact number of UEs that need to respond to counting is as an RRM issue as well.

14.2.3 MBMS RRM p-t-p / p-t-m switching strategies

In general terms, MBMS RRM switching criteria between p-t-p and p-t-m connections relies on UE counting procedure, a-priori planning and link budget considerations, based on the worst case, i.e. all the UEs involved in the MBMS service are assumed to be at the cell edge.

In fact, by planning and link budget calculations it is possible to estimate the maximum transmit power required by one p-t-p transport channel (DCH or HS-DSCH) in downlink to accommodate the MBMS service for a user located at the cell edge. Hence it is also possible to estimate if the total worst case transmitted power required in downlink by $n * p-t-p$ channels (where n is the number of MBMS UEs estimated by the counting procedure) is lower than the transmitted power allocated to S-CCPCH to which the MBMS service is mapped. As an example, the pole capacity function can be used in order to estimate the maximum transmitted power in downlink for a DCH for a given service or an equivalent formula can be used for HS-DSCH.

A more accurate strategy could be based both on UE counting and instantaneous estimation of the actual downlink transmitted power required in the case of p-t-p transmission, depending on the UEs location. In fact, due to the different physical locations of UEs, each one experiencing different fading and path loss, and a more effective decision can be taken about the switching point between p-t-p and p-t-m.

The following picture provides an example of MBMS p-t-p/p-t-m switching algorithm adopting a decision criterion based both on UE counting and the estimation of the total DCH downlink transmitted power required to accommodate each UE that activated an MBMS service.

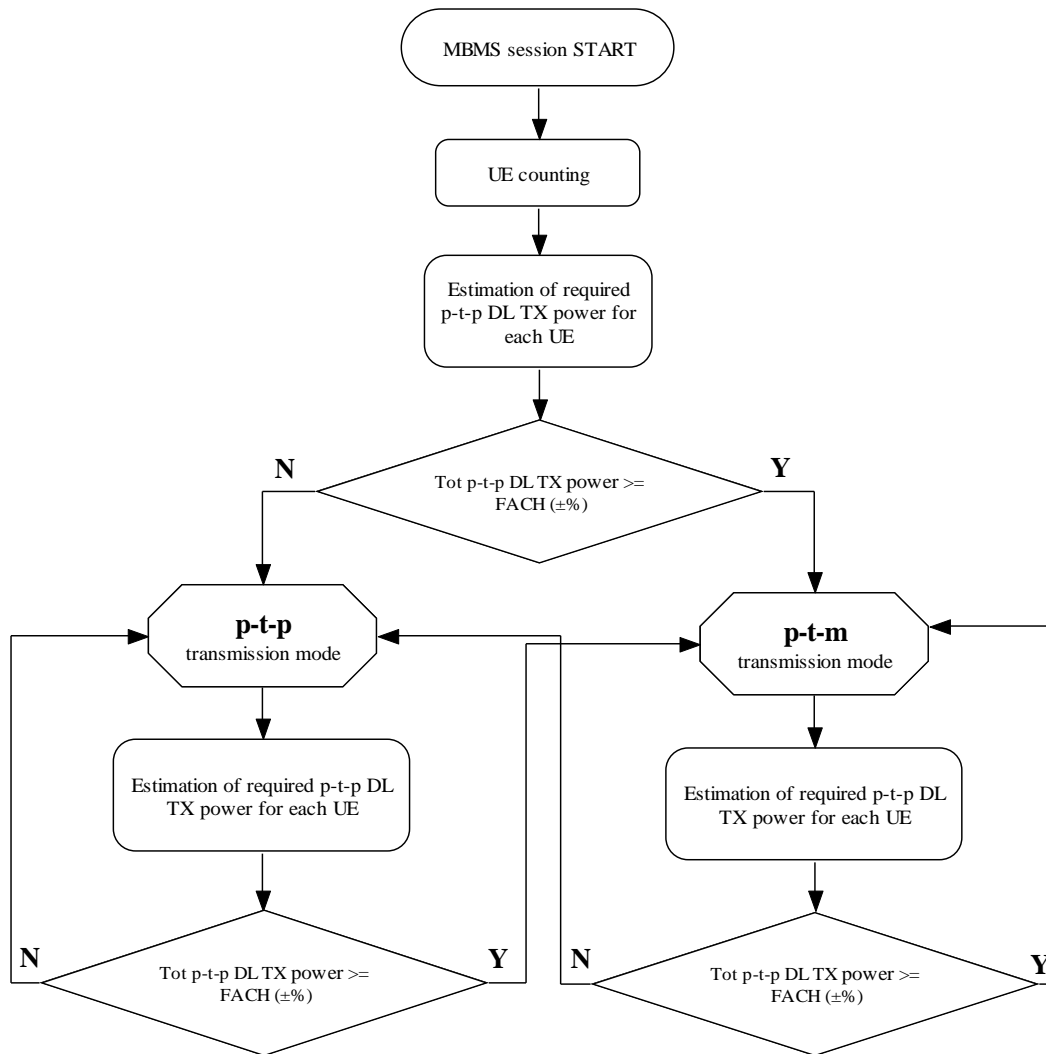

Figure 14.2.3-1: Example of MBMS p-t-p / p-t-m switching algorithm

In case the UTRAN needs to perform instantaneous estimation of the downlink power required by a given UE, the following procedures can be used:

- **Initial selection of transmission type:** when the MBMS session starts, it is possible to exploit the UE counting procedure. During RRC connection establishment procedure, path-loss information can be reported by UEs when responding to the counting request;
- **p-t-p to p-t-m transition:** when p-t-p transmission is used, CRNC can configure the base station to measure and to report the instantaneous downlink transmitted power for each radio link. Hence, CRNC is aware of the instantaneous downlink power required by the p-t-p transmission and this information can be used to periodically check if the condition for p-t-m transmission is met;
- **p-t-m to p-t-p transition:** when p-t-m transmission is used, CRNC can periodically perform a counting procedure and use the path loss information reported by the UEs that respond to counting.

Due to the amount of signalling information needed for counting and measurement reporting, further optimization is also possible. In fact, when the number of UEs involved in the MBMS service is lower than a threshold, the p-t-p transmission can be set regardless of accurate power estimation. On the other hand, also when the number of UEs involved in the MBMS service is higher than another threshold, the p-t-m transmission can be set regardless of accurate power estimation. In this sense, only if the number of users is within a specific range, a more accurate counting and power dependent selection criterion should be adopted in order to take the optimal decision.

In case the combining is configured for some cells, the switching from p-t-m to p-t-p should be applied also taking into account the loss of combining gain, both in the cell where the counting is performed and in the neighbouring cells.

Annex A:

Simulations on Fast Dynamic Channel Allocation

A.1 Simulation environment

The presented simulations are performed in the following environments and services according to the requirements in the following documents:

- ETSI TR 101 112, Selection procedures for the choice of radio transmission technologies of the Universal Mobile Telecommunications System UMTS (UMTS 30.03), version 3.2.0, April 1998.
- Seppo Hämäläinen, Peter Slanina, Magnus Hartman, Antti Lappeteläinen, Harri Holma, Oscar Salonaho, A Novel Interface Between Link and System Level Simulations, Acts Mobile Communications Summit '97, pp. 599-604, Aalborg/Denmark, Oct 7-10, 1997.

Absolute capacities [kbit/s/MHz/cell] were published in:

- ETSI Tdoc SMG2 306/98, UTRA TDD Link Level and System Level Simulation Results for ITU Submission, Source: Siemens, Helsinki, Sep 8-11, 1998.
 1. Macro (Vehicular) environment for the UDD 144 kbit/s service.
 2. Micro (Outdoor-to-Indoor Pedestrian) environment for the UDD 384 kbit/s service.

A.2 Results

The relative load of the cell is used for the abscissa (horizontal axis) in all of the plots. Here, a relative load of 100% refers to the maximum cell load obtainable with code-pooling under the ETSI unsatisfied user criterion (in accordance with ETSI TR 101 112). Vertically, the percentage of unsatisfied users is shown.

A.2.1 Void

A.2.2 Micro UDD 384

In the Micro environment the UDD 384 service is simulated using ARQ and code-rates 1 and 2/3.

A.2.2.1 Code rate 1

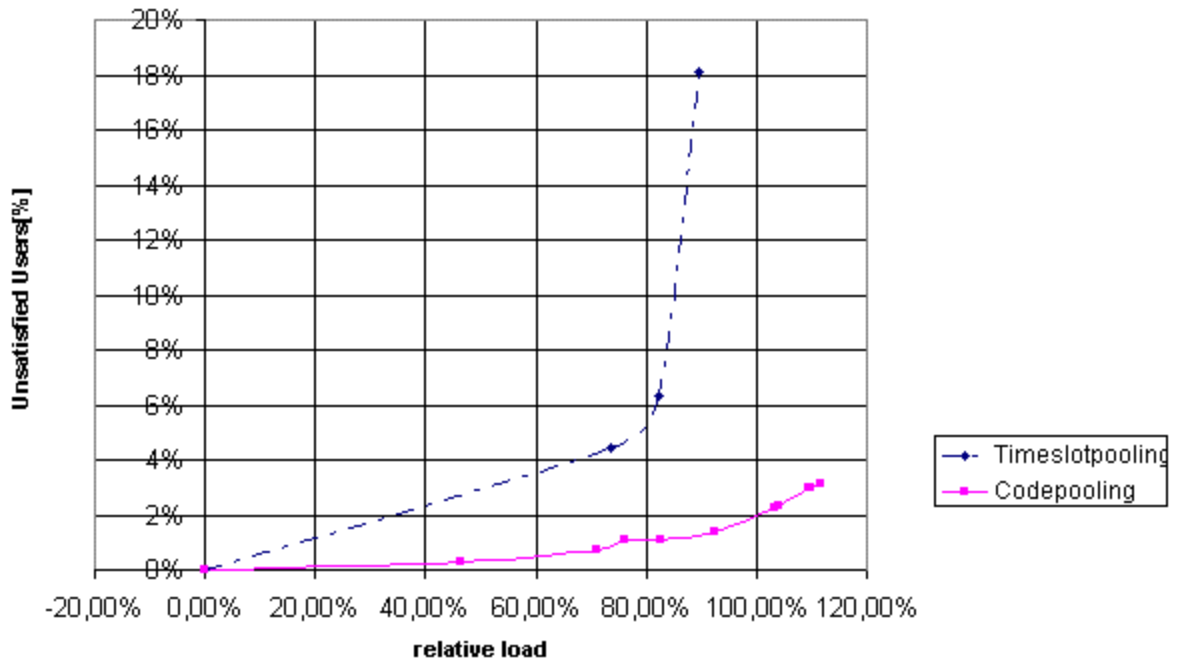

Figure A-2

A.2.2.2 Code rate 2/3

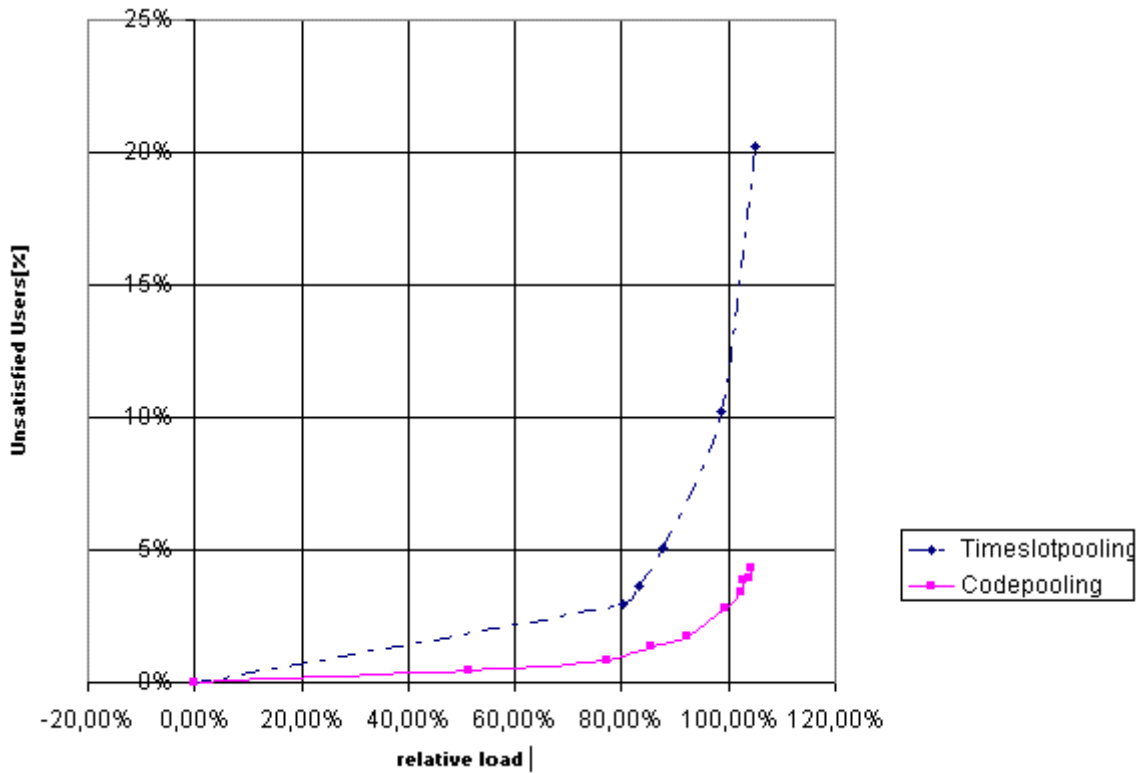

Figure A-3

A.3 Conclusions

Code pooling performs better than time slot pooling. This is explained as follows. When code-pooling is applied, the whole PDU depends on the same interference level on all codes: the probabilities of low CIR on each spreading -code within the same timeslot are strongly coupled.

- The probability of PDU transmission failure for code-pooling is approximately the same as the probability of low CIR in a single timeslot.
- The probability of PDU transmission failure for timeslot-pooling is approximately the same as the probability of low CIR in at least one of the used timeslots.

This advantage of code-pooling results in lower numbers of unsatisfied users. These results clearly recommend that the DCA prefers code pooling over timeslot pooling for UDD packet data in TDD mode.

Annex B: Radio Bearer Control – Overview of Procedures: message exchange and parameters used

B.1 Examples of Radio Bearer Setup

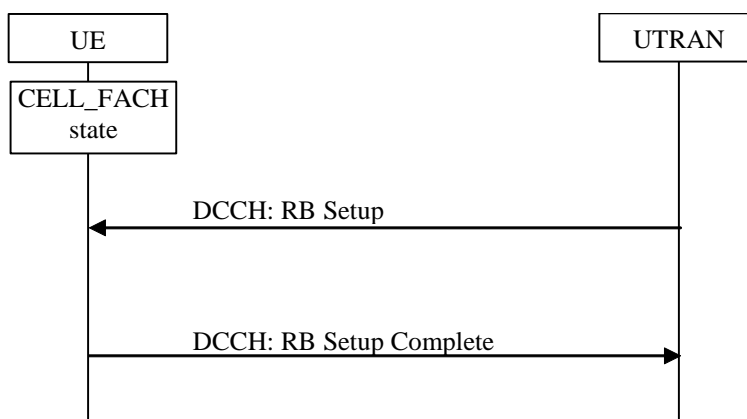

Figure B-1: Radio Bearer setup on common transport channel

B.1.1 RRC Parameters in RB Setup

This message includes the IE "RB identity" for the new RB and "RLC info". It also includes "RB mapping info" with two different multiplexing configurations, one for each transport channel this RB could be mapped onto. One configuration is used to map the RB on a common transport channel and one to map the RB on a dedicated transport channel.

This message changes the configuration of the common transport channel including a new "Transport format set" for FACH and one for RACH.

This message also adds the configuration for two dedicated transport channels (DCH1 and DCH2) that can be used later (e.g. after the switch – see B.2.1) and includes the "Transport Formats Set" and the "Transport Format Combinations" to be used with that configuration.

B.1.2 Void

B.2 Examples of Physical Channel Reconfiguration

Below several examples of Physical Channel reconfigurations are shown, triggered by different amount of UL or DL data.

B.2.1 Increased UL data, with switch from CELL_FACH to CELL_DCH

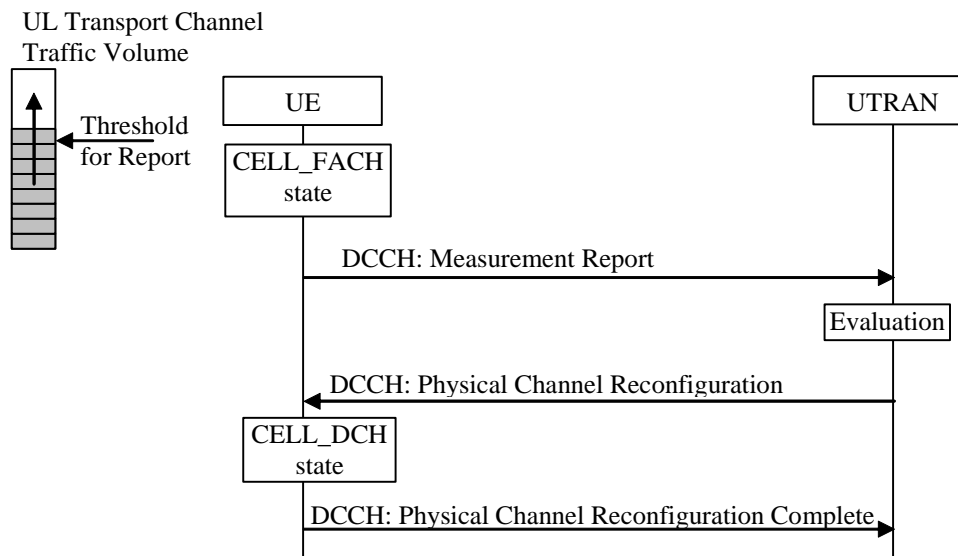

Figure B-2: Physical channel reconfiguration triggered by increased UL data and with a switch from CELL_FACH to CELL_DCH

B.2.1.1 RRC Parameters in Measurement Report

This message includes a "Measurement Identity" so that UTRAN can associate this report with a Measurement control message. It also includes the "Measured results" stating "RB Identity" and optionally "Reporting Quantities" for each RB (i.e. RLC Buffer Payload, Average of RLC Buffer Payload, and Variance of RLC Buffer Payload).

B.2.1.2 RRC Parameters in Physical Channel Reconfiguration

This message includes "DL channelisation codes" and "DL scrambling code" for the DPCH. It also includes "UL channelisation" codes and "UL scrambling code" for the DPCH. In order to perform a transport channel type switching, the IE "RRC state indicator" is set to "CELL_DCH".

B.2.1.3 Void

B.2.2 Increased DL data, no Transport channel type switching

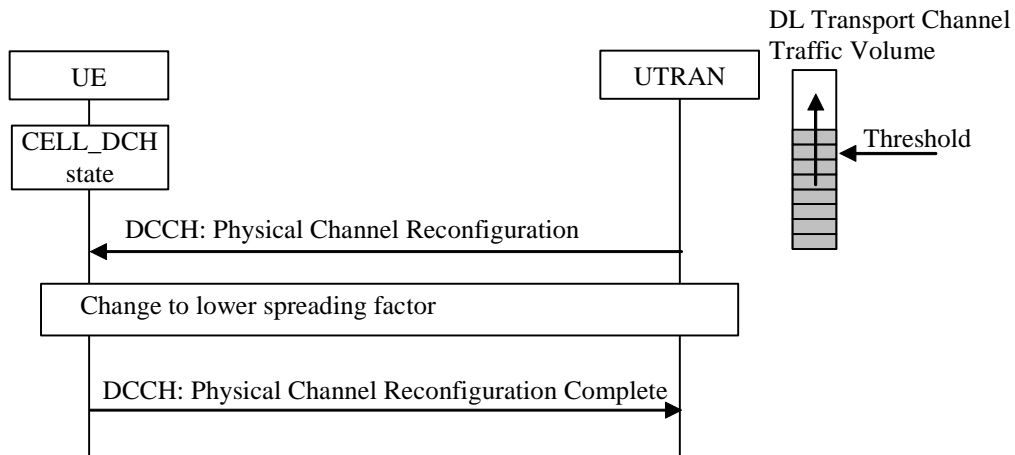

Figure B-3: Physical channel reconfiguration triggered by increased DL data and configuration in UTRAN DL

B.2.2.1 RRC Parameters in Physical Channel Reconfiguration

This message includes "DL channelisation codes" for the DPCH with lower spreading factor for all cells that the UE is connected to.

B.2.2.2 Void

B.2.3 Decrease DL data, no Transport channel type switching

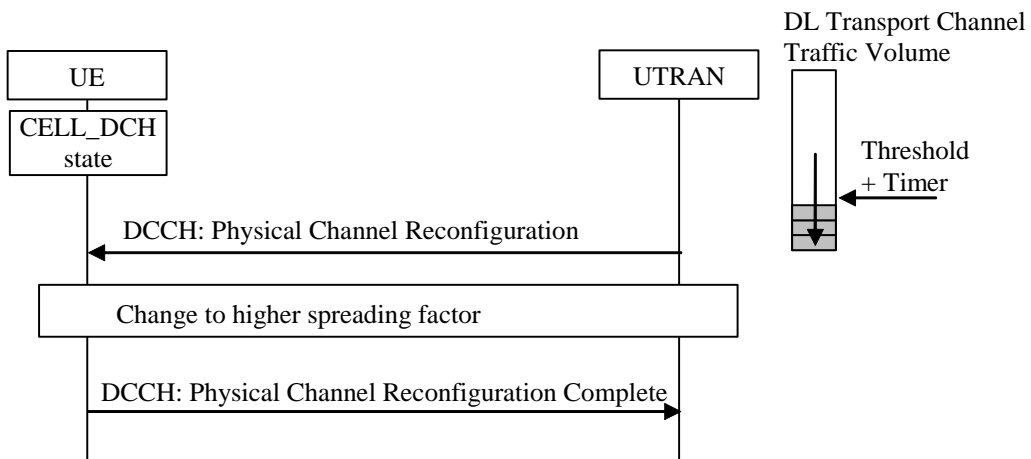

Figure B-4: Physical channel reconfiguration triggered by decreased DL data and configuration in UTRAN DL

B.2.3.1 RRC Parameters in Physical Channel Reconfiguration

This message includes "DL channelisation codes" for DPCCH with higher spreading factor for all cells that the UE is connected to.

B.2.3.2 Void

B.2.4 Decreased UL data, with switch from CELL_DCH to CELL_FACH

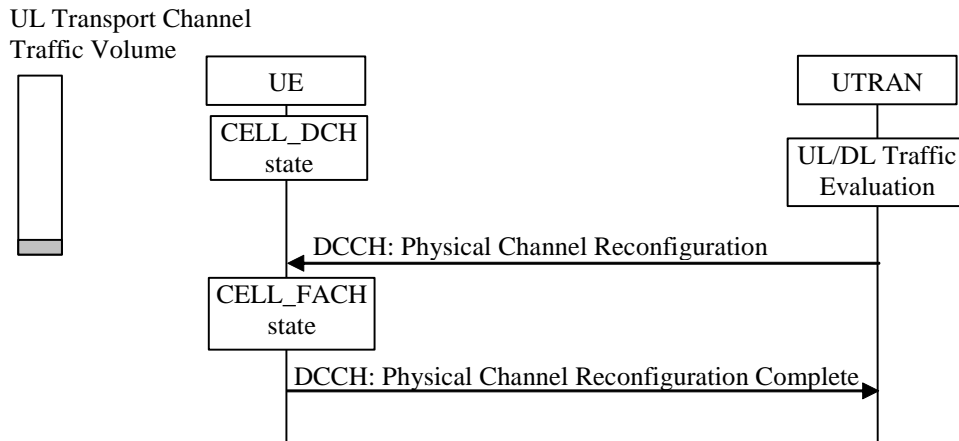

Figure B-5: Physical channel reconfiguration triggered by decreased UL data and with a switch from CELL_DCH to CELL_FACH

B.2.4.1 RRC Parameters in Physical Channel Reconfiguration

In order to perform a transport channel type switching, the IE "RRC state indicator" is set to "CELL_FACH". The UE reads the configurations for PRACH and the S-CCPCH from the System Information after the state transition.

B.2.4.2 Void

B.3 Examples of Transport Channel Reconfiguration

B.3.1 Increased UL data, with no transport channel type switching

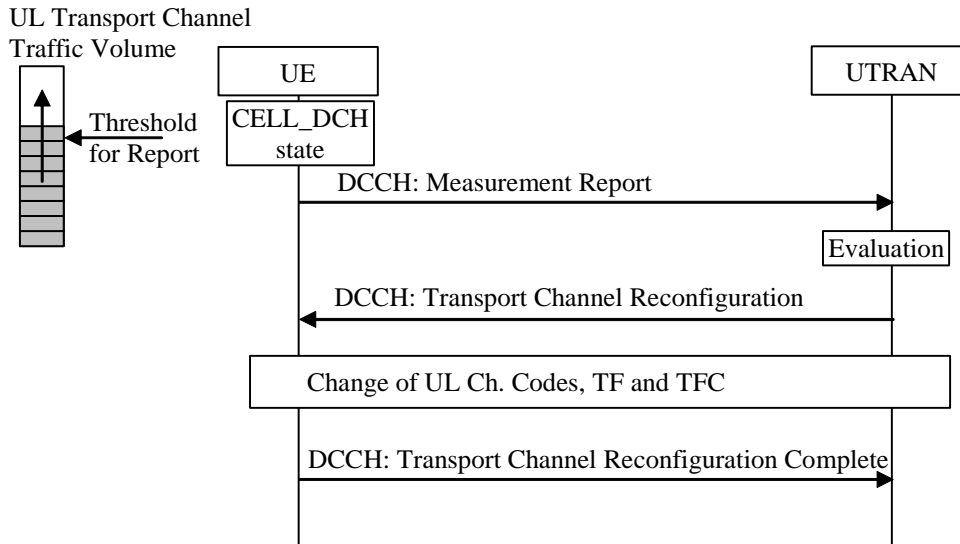

Figure B-6: Transport channel reconfiguration triggered by increased UL data and configuration in UTRAN DL

B.3.1.1 RRC Parameters in Measurement Report

This message includes the IE "Measurement Identity" number so that UTRAN can associate this report with a Measurement control message. It also includes the "Measured results" stating "RB Identity" and optionally "Reporting Quantities" for each RB (i.e. RLC Buffer Payload, Average of RLC Buffer Payload, and Variance of RLC Buffer Payload).

B.3.1.2 RRC Parameters in Transport Channel Reconfiguration

This message includes a "Transport format set" for DCH2 and a "Transport format combination set".

It also includes "UL channelisation codes" for the DPCH.

B.3.1.3 Void

B.3.2 Void

B.3.2.1 Void

B.3.2.2 Void

B.4 Examples of RB Reconfiguration

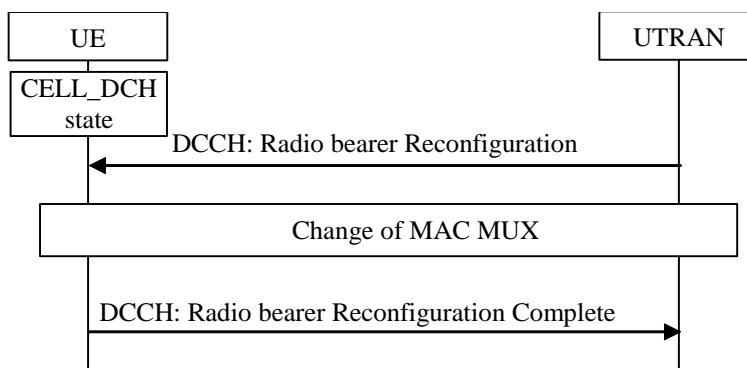

Figure B-8: RB Reconfiguration

B.4.1 RRC Parameters in Radio Bearer Reconfiguration

This message includes a multiplexing option with Transport channel identity DCH2 for both RB5 and RB6, stating that both these RBs should use the same transport channel. For each of these two RBs a "Logical channel identity" value and a "priority" must be given to define the MAC MUX.

Also included is a new "Transport format set" for DCH2 and a new "Transport format combination set" (both for UL and DL if the multiplexing is changed both in UL and DL).

It is also possible to reconfigure the physical channel and include new channelisation codes for the DPCH with different spreading factor for all cells that the UE is connected to.

B.4.2 Void

Annex C: Flow-chart of a Soft Handover algorithm

In this Appendix a flow-chart of the Soft Handover algorithm described in section 5 is presented.

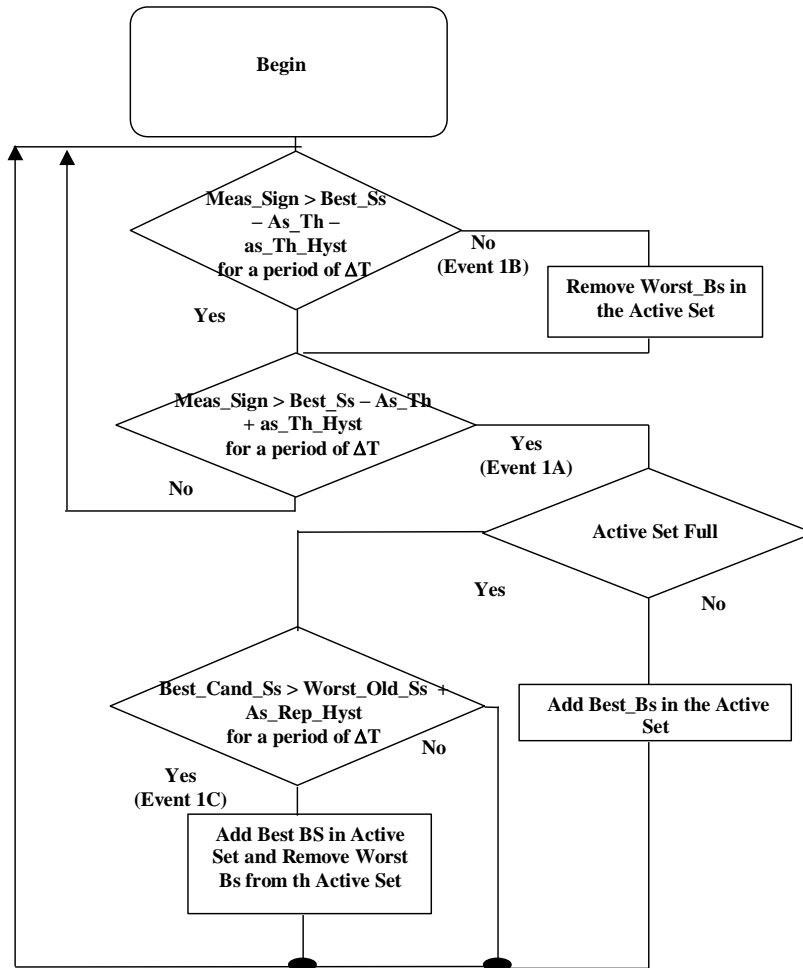

Figure C-1: flow-chart of a Soft Handover algorithm

Annex D:
Void

Annex E: Simulation results on DL Variable Rate Packet Transmission

E.1 Simulation assumption

The simulation model is based on the ARIB's model used for RTT proposal. Following are detailed assumptions :

- down-link, vehicular environment system-level simulation (ITU model);
- perfect SIR estimation (no delay on SIR estimation);
- UDD144k users and SPEECH users are considered;
- voice activation of 50 % for SPEECH service;
- traffic call model is not introduced for UDD service (continuous transmission).

Other simulation parameters are shown in Tables 17.1 and 17.2.

Table E-1: Environment models

Cell radius	1000 m
Site to site separation	3000 m
Cell layout	wrap around
Data sample cell	all cells
# of sectors	3
UE speed	120 km/h

Table E-2: Power setting and other parameters

	SPEECH 8kbps	UDD 144kbps
Diversity	No	No
Processing gain	512 (27.1dB)	67.4 (18.3dB)
TCH max. TX power	30 dBm	30 dBm
TCH min. TX power	10 dBm	10 dBm
BCH TX power	30 dBm	30 dBm
HO algorithm settings		
DHO windows	3 dB	N/A
Active set update rate	0.5 second	0.5 second
Active set max. size	2	1
Required Eb/No	8.8 dB	2.9 dB
TCH allowable TX power (TXPOW_ALLOWABLE)	-	30, 27, 24 dBm
Number of users	60, 62, 64, 68, 70	5

E.2 Simulation results

Tables 17.3, 17.4 and 17.5 are simulation results for TXPOW_ALLOWABLE of 30, 27 and 24 dBm, respectively. In these tables, 'satisfied user' means the user having sufficiently good quality, i.e., the required Eb/No is satisfied, more than 95% of the session time. The results show that:

- Compared with "Fixed Rate", "Variable Rate" can achieve the same or higher data rate as well as better quality for both services.
- "Variable Rate" can accommodate more users by allocating a lower power threshold for high-rate packet users.

- "Variable Rate" can control the average transmission power not only for UDD144k users but also for SPEECH users. This means that "Variable Rate" can keep the system stable by allocating an appropriate power threshold (TXPOW_ALLOWABLE).

Because of these advantages, the system may tolerate high-power emergent users.

Table E-3: Simulation results for TXPOW_ALLOWABLE = 30 dBm

Number of users (SPEECH + UDD144k)	Fixed Rate				Variable Rate				
	SPEECH		UDD144k		SPEECH		UDD144k		
	satisfied user	Average TXPOW [dBm]	Satisfied user	average TXPOW [dBm]	satisfied user	average TXPOW [dBm]	satisfied user	average TXPOW [dBm]	average data rate [times]
60 + 5	100 %	21.9	93.6 %	25.8	97.58 %	23.8	90.82 %	28.6	1.59
62 + 5	100 %	22.8	41.6 %	26.6	99.59 %	28.6	97.26 %	28.6	1.44
64 + 5	-	-	-	-	99.97 %	28.6	99.54 %	28.6	1.31
66 + 5	-	-	-	-	100 %	28.6	100 %	28.6	1.18
68 + 5	-	-	-	-	100 %	28.6	99.98 %	28.6	1.04
70 + 5	-	-	-	-	99.94 %	28.6	100 %	28.6	0.91

Table E-4: Simulation results for TXPOW_ALLOWABLE = 27 dBm

Number of users (SPEECH + UDD144k)	Fixed Rate				Variable Rate				
	SPEECH		UDD144k		SPEECH		UDD144k		
	satisfied user	Average TXPOW [dBm]	satisfied user	average TXPOW [dBm]	satisfied user	average TXPOW [dBm]	satisfied user	average TXPOW [dBm]	average data rate [times]
60 + 5	100 %	21.9	93.6 %	25.8	99.98 %	25.6	99.92 %	25.6	1.29
62 + 5	100 %	22.8	41.6 %	26.6	100 %	25.6	100 %	25.6	1.19
64 + 5	-	-	-	-	100 %	25.6	100 %	25.6	1.08
66 + 5	-	-	-	-	100 %	25.6	100 %	25.6	0.97
68 + 5	-	-	-	-	100 %	25.6	100 %	25.6	0.85

Table E-5: Simulation results for TXPOW_ALLOWABLE = 24 dBm

Number of users (SPEECH + UDD144k)	Fixed Rate				Variable Rate				
	SPEECH		UDD144k		SPEECH		UDD144k		
	satisfied user	Average TXPOW [dBm]	satisfied user	average TXPOW [dBm]	satisfied user	average TXPOW [dBm]	satisfied user	average TXPOW [dBm]	average data rate [times]
60 + 5	100 %	21.9	93.6 %	25.8	100 %	22.6	100 %	22.6	0.97
62 + 5	100 %	22.8	41.6 %	26.6	100 %	22.6	100 %	22.6	0.88
64 + 5	-	-	-	-	100 %	22.6	100 %	22.6	0.79

Annex F: Simulation results on Adjustment loop

F.1 Simulation conditions

The performance of adjustment loop is evaluated by means of computer simulation. The assumptions of the simulation are as follows:

- Active set is determined when a call is originated. During the call, sector average of path loss does not change, and the active set is not updated.
- Maximum active set size is three. Relative threshold for soft handover is 6 dB.
- Initial DL power is set to a value common to all active set cells.
- During a call, DL power is not synchronised by messages from RNC.
- Average holding time is 10 sec.
- Path loss of 3.5th power law, log-normal shadowing, and equal level 4 path Rayleigh fading are considered.
- Both uplink and downlink power is updated by inner loop power control in every slot.
- Delay of inner loop power control is one slot.
- Outer loop power control is employed, in which target FER is 0.01.
- Step size of inner loop power is 1 dB.
- When the SIR of TPC command is smaller than a threshold, the degraded TPC command is not used for inner loop power control.
- Reception error of TPC commands is generated in accordance with received SIR.
- Power control range is 20 dB.
- DL reference power P_{REF} is the centre value of power control range.
- DL power convergence coefficient r is 0.96.

F.2 Simulation results

Figure F-1 shows average of DL power difference among cells during soft handover, Figure F-2 shows FER, and Figure F-3 shows average DL power of all calls. During soft handover, DL power is the sum of DL powers of the active set cells. In these figures, performance with adjustment loop (ON) is compared with the performance without adjustment loop (OFF). The performance depends on the DL reference power, i.e. the centre value of the power control range. In this result, ratios of active set size of two and three were both 0.22, and both degraded TPC command rate and TPC error rate were approximately 2 percent.

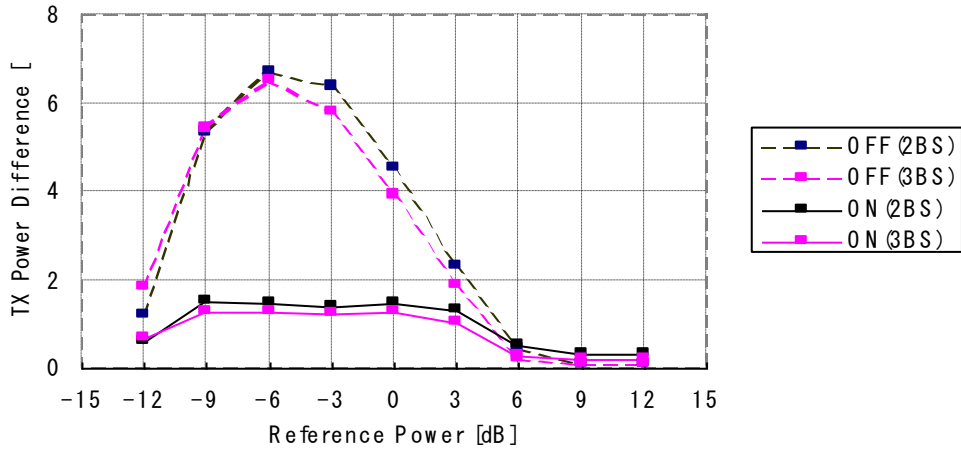

Figure F-1: DL power difference

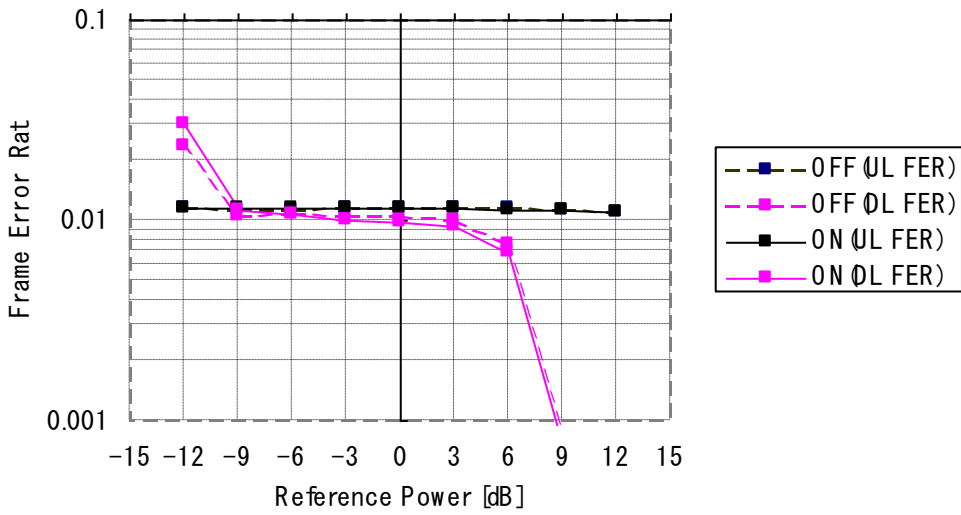

Figure F-2: Frame Error Rate

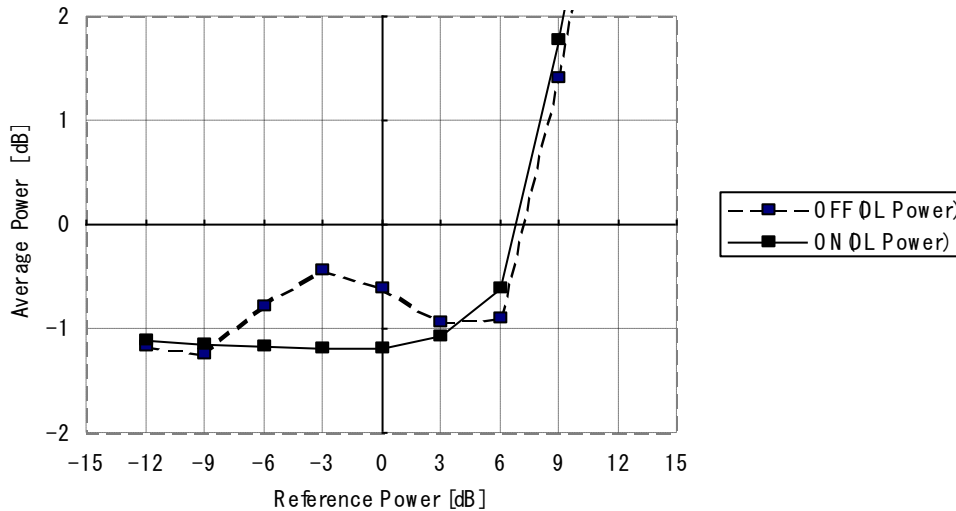

Figure F-3: Average DL power

F.3 Interpretation of results

When the reference power is between -9 dB and 6 dB, FER is maintained at a target value and average DL power stays relatively low. However, when the reference power is less than -9 dB, FER becomes large due to small maximum DL power. On the other hand, when the reference power is more than 6 dB, average DL power is increased due to large minimum DL power.

When adjustment loop is not employed, average DL power depends on the centre value of power control range. With adjustment loop, average DL power is not sensitive to the centre value of power control range. This means that it is possible to keep DL power low quite easily.

With adjustment loop, it is possible to eliminate power drifting problem without the need of frequent signalling of DL Reference Power, and without negative impact on DL inner loop power control.

During soft handover, DL Reference Power is reported from RNC to Node-Bs in NBAP messages. If synchronised Radio Link Reconfiguration is not used, power drifting cannot be eliminated since it is not possible to set the DL Reference Power at all Node-Bs at the same time. If synchronised Radio Link Reconfiguration is used, there is a high probability that the difference of the DL Reference Power and the current DL power is large due to large delays. In such cases, if DL power is set equal to DL Reference Power in a slot in each Node-B, the DL power may become too low or too high. Therefore this may have significant negative impact on DL inner loop power control. It should be also noted that frequent signalling of DL Reference Power will have significant increase of control traffic from RNC to Node-B.

With adjustment loop, DL power adjustment is much smaller than a step of inner loop power control even when the difference of the DL Reference Power and the current DL power is large. This means that it is possible to achieve the high performance of DL inner loop power control.

Annex G: Simulation results for CPCH

This appendix presents the results of CPCH simulations performed with the OPNET Modeller tool for various traffic loading and cell capacity scenarios. Simulation assumptions and results are presented. The last subclause of the appendix presents RRM strategies based on the simulation results.

G.1 Simulation Assumptions

- Results of Link Level Simulations with ITU channel model is used.
- The preamble detection probability as a function of SNR.
- Window-based and timer-based ARQ is used. So it was captured end-to-end delays.
- 50-200 mobiles are randomly distributed in the coverage area of one cell.
- The access Preamble ramp-up and the collision resolution steps are simulated.
- Each packet is processed serially and independently of others, i.e. aggregation of packets in the UE is not simulated.
- The following tuneable parameters exist in the simulations:
 - N_Max_Frames: maximum length in frames of individual packet.
 - Number of ramp-ups max: number of AP power ramp up cycles without APCH response before access is aborted and packet transmission fails.
 - Traffic model: includes packet inter-arrival time, session inter-arrival time, # of packets per packet call, number of packet calls per session, Session length, average packet size, etc.
 - Three various CPCH channel selection algorithms.
- The following traffic model is used in the simulations:
 - Average packet size: E-mail application 160, 480, 1000 bytes.
 - # of packets in a packet call = 15.
 - Packet call inter-arrival time = 0,120.
 - # of packet calls within a session =1.
 - Average inter-packet arrival time = 30, 100, 200 ms.
 - CPCH channel data rates: 2.048 Msps (512 kbps), 384 ksps (96 kbps), 144 ksps (36 kbps), 64 ksps (16 kbps).
 - Session arrival = Poisson.
- The following results are captured:
 - End-to-End Delay, D(e-e), includes UL retransmissions and DL ACK transmission.
 - Unacknowledged Mode End-to-End Delay, D(un).
 - RLC queuing delay, QD.
 - Radio Access Delay, AD.
 - MAC collisions, event count for event in which 2 UE attempt access to same CPCH channel in same slot.

- Throughput (S1) includes ARQ re-transmissions/ excludes detected MAC collisions/excludes undetected collisions as well.
- Unacknowledged Mode Throughput (S2) excludes ARQ re-transmissions / excludes MAC collisions.
- Offered Load (ρ), total offered traffic normalised to total available capacity (bandwidth).
- Undetected collisions per sec.
- Detected collisions per sec.

G.2 CPCH Channel Selection Algorithms

The three CPCH channel selection algorithms are: Simple, recency, idle-random.

G.2.1 Simple CPCH channel selection algorithm

In this method, the UE monitors the available capacity and the highest available rate from the Base Node. The UE then picks a CPCH channel and a slot randomly and contends for the CPCH.

G.2.2 The recency table method

In this method, the UE monitors the AP-AICH and constructs a recency table, which includes time-stamps, which aid the selection of the CPCH channel. The simulation assumes perfect knowledge of the transmission of AP-AICH (CPCH channel transition from idle to busy) from the base Node. In reality, there will be discrepancies in the information in the table since the UE is required to receive FACH and DL-DPCCH (while transmitting on the UL CPCH) and thus will may not be able to receive all AP-AICHs. The UE selects the CPCH channel with the oldest AP-AICH timestamp.

G.2.3 The idle-random method

In this method, the UE monitors the idle-AICH (channel idle) and AP-AICH (channel busy) and has perfect information on the availability of the CPCH channels. The UE monitors the AP-AICH and CD-AICH for 10 ms. then it picks a CPCH channel randomly from the available ones in the desired data rate category. Note that this method is sensitive to back-off methods. When the traffic load is high and there are multiple CPCH channels, this method outperforms the other methods given the right back-off parameters.

G.3 Simulation Results

G.3.1 Cases A-B: Comparison of idle-random method and the recency method for 30 ms packet inter-arrival time, 480 bytes, and 6 CPCH channels, each @384 ksps

36 cases were ran over to compare the throughput delay performance of the two methods when the packet inter-arrival time is 30 ms. This was done for various packet lengths (158 bytes, 480 bytes, 1000 bytes, 2000 bytes), various rates (6 CPCH @ 384 ksps, 16 CPCH @ 144 ksps, 32 CPCH @ 64 ksps), various N_Max_Frames (8,16,24,32,64), and the three CPCH channel selection algorithms. In all cases, the idle-random method performed better. When the packet inter-arrival time was increased, the throughput delay performance of the recency method almost overlapped with the idle-random case (see Scenarios C-D-E).

Results presented here compare idle-random method and the recency method for 30 ms packet inter-arrival time, 480 bytes, and 6 CPCH @ 384 ksps:

Table G-1: Idle random case

	S1	D(e-e)
.34	.33	.3
.44	.42	.338
.53	.5	.375
.65	.70	.430
.95	.76	.92

Table G-2: Recency table case

	S1	D(e-e)
.36	.335	.36
.45	.42	.375
.67	.583	.55
.97	.76	1.73

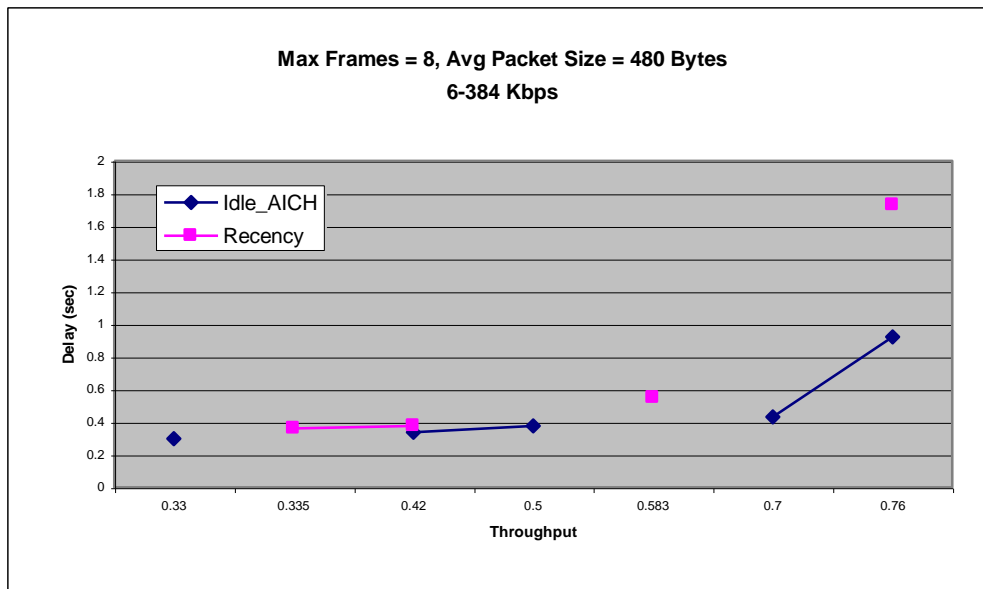

Figure G-1: Delay vs. Throughput

G.3.2 Case C-D-E: Comparison of the three methods for multiple CPCH

Recency table and the idle random methods out-perform the simple case significantly. However, the recency method performs almost as well as the idle-random case in these simulation runs for two reasons: 1) the recency table case in the simulation does not have any discrepancies in its information 2) the back-off for idle-random is not optimised and therefore it performs slightly worse when the packet inter-arrival time is high (e.g., 100 ms).

At $D(un)$ of 300 ms, we have the following throughputs:

Simple case, $S1 = .55$.

Recency table: $S1 = .8$.

Idle-random $S1 = .78$.

Table G-3, Table G-4, Table G-5 provide results for the comparison of the three CPCH channel selection algorithms considering:

Packet inter-arrival time 100 ms.

Maximum frame per packet 8.

Average packet size

480.

12 channels:

4 – 384 CPCH; 4 – 144 CPCH; 4 – 64 CPCH.

Table G-3: E-mail_1_with the simple algorithm

Sess	ρ	S1	D(un)	QD	AD	TD	MAC Collision
20	0.310	0.280	0.121	0.070	0.013	0.038	677,000.000
16	0.390	0.360	0.155	0.100	0.015	0.039	106,000.000
10	0.630	0.550	0.300	0.237	0.020	0.042	266,000.000
8	0.776	0.650	0.660	0.589	0.025	0.045	436,700.000
6.8	0.923	0.76	1.324	1.245	0.033	0.046	714,700.000
6.6	1.00	0.812	3.23	3.15	0.036	0.047	983,300.000

Table G-4: E-mail_1_with the recency table algorithm

Sess	ρ	S1	D(un)	QD	AD	TD	MAC Collision
20	0.283	0.280	0.110	0.062	0.009	0.038	96,500.000
16	0.380	0.377	0.116	0.069	0.010	0.038	162,000.000
12	0.477	0.470	0.131	0.081	0.012	0.038	251,000.000
10	0.566	0.565	0.140	0.088	0.014	0.038	354,700.000
8	0.779	0.736	0.203	0.149	0.016	0.038	733,300.000
7.1	0.846	0.800	0.290	0.235	0.017	0.038	860,000.000

Table G-5: E-mail_1_with the idle random algorithm

Sess	ρ	S1	D(un)	QD	AD	TD	MAC Collision
20	0.282	0.280	0.102	0.056	0.007	0.039	65,100.000
16	0.351	0.350	0.118	0.072	0.007	0.039	89,000.000
12	0.458	0.454	0.124	0.076	0.008	0.040	137,500.000
10	0.558	0.554	0.148	0.109	0.008	0.041	215,000.000
8	0.667	0.657	0.211	0.160	0.009	0.042	344,000.000
7.1	0.741	0.736	0.260	0.208	0.010	0.043	472,000.000
6.5	0.825	0.800	0.350	0.296	0.012	0.043	644,000.000
6.3	0.876	0.837	0.544	0.488	0.013	0.043	765,300.000

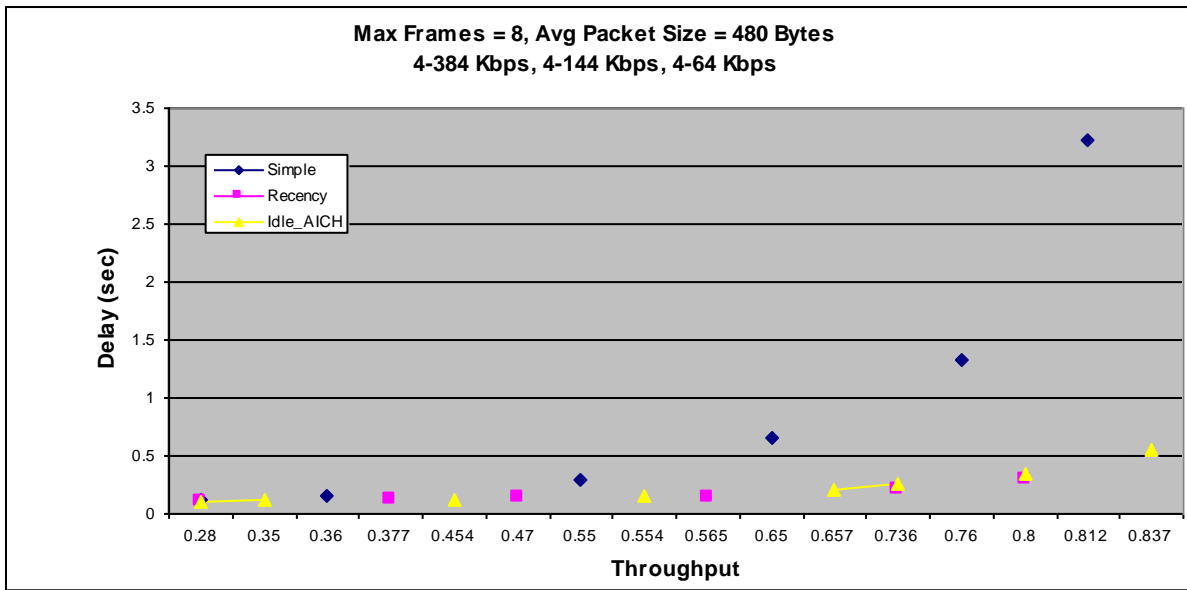

Figure G-2: Delay vs. Throughput

G.3.3 Cases E-F: Impact of packet inter-arrival time

Increasing the packet inter-arrival time from 100 to 200 ms, the throughput delay performance improves significantly. Increasing the packet inter-arrival time, the packet model resembles the Poisson arrival model more. The motivation to increase the packet inter-arrival time to improve the overall delay performance of all methods. This can be achieved in practice by having the TFCI and being able to send more packets during a single CPCH transmission if it arrives in the RLC buffer. This is quite possible from a single logical channel. Both Table 19.6 and Table 19.7 provide results for:

Idle Random Algorithm.

Average packet size 480.

16 CPCH channels: 4 – 384 CPCH; 4 – 144 CPCH; 4 – 64 CPCH.

Case E (Table G-6) corresponds to packet inter-arrival time of 100 ms presented in the previous subclause (Table G-5), which is repeated here for convenience. Table G-7 addresses the case of 200 ms packet arrival time.

Table G-6: E-mail_1_with idle random algorithm

Sess	ρ	S1	D(un)	QD	AD	TD	MAC Collision
20	0.282	0.280	0.102	0.056	0.007	0.039	65,100.000
16	0.351	0.350	0.118	0.072	0.007	0.039	89,000.000
12	0.458	0.454	0.124	0.076	0.008	0.040	137,500.000
10	0.558	0.554	0.148	0.109	0.008	0.041	215,000.000
8	0.667	0.657	0.211	0.160	0.009	0.042	344,000.000
7.1	0.741	0.736	0.260	0.208	0.010	0.043	472,000.000
6.5	0.825	0.800	0.350	0.296	0.012	0.043	644,000.000
6.3	0.876	0.837	0.544	0.488	0.013	0.043	765,300.000

Table G-7: E-mail_3_with idle random algorithm

Sess	ρ	S1	D(un)	QD	AD	TD	MAC Collision
20	0.275	0.273	0.067	0.022	0.007	0.038	61,600
16	0.329	0.326	0.074	0.028	0.007	0.039	81,900
10	0.470	0.467	0.076	0.029	0.008	0.040	152,700
8	0.558	0.554	0.079	0.031	0.008	0.041	233,300
7	0.616	0.610	0.091	0.041	0.009	0.042	300,000
6.5	0.656	0.647	0.142	0.091	0.009	0.042	345,300
6.3	0.681	0.673	0.112	0.061	0.009	0.042	388,000
4.95	0.819	0.79	0.178	0.123	0.012	0.043	637,000
4.9	0.867	0.824	0.205	0.148	0.014	0.043	746,700

G.3.4 Case G: Number of mobiles in a cell

There could potentially be hundreds of UEs in parallel session as shown by the table in this case. In third case, there are 930 UEs in parallel session if 25% of the capacity was allocated to Packet Data services. Idle-Random CPCH channel is used. There are 6 CPCH channels @ 384ksps which is equivalent to 25% of cell capacity. Table G-8 addresses the case of 200 ms packet inter-arrival time.

Table G-8: Delay vs. Number of UEs @ 25% of cell

Mobiles	ρ	S1	D(un)	QD	AD	TD	MAC Coll
318	.257	.256	.08	.031	.011	.038	55,766
750	.609	.604	.137	.078	.017	.042	300,000
930	.798	.772	.241	.175	.022	.044	595,000

G.3.5 Case H-I: Comparison of recency and idle-random methods for single CPCH

The recency method outperforms the random-idle for a single CPCH case and high inter-arrival time of 200 ms as shown by tables in cases F and G. The reason for this is the non-optimised back-off mechanism for the random-idle case. Table G-9 and Table G-10 compare recency and idle-random methods assuming a single 2 Msps CPCH, 200 ms packet inter-arrival, 480 bytes messages.

Table G-9: Idle-random method

ρ	S1	D(un)	QD	AD	TD	MAC Coll
.56	.535	.23	.171	.0448	.0137	200,833
.768	.684	.97	.883	.0729	.0137	398,000

Table G-10: Recency Table method

ρ	S1	D(un)	QD	AD	TD	MAC Coll
.574	.634	.0927	.057	.022	.0137	153,333
.813	.675	.131	.086	.031	.0136	318,666

G.3.6 Case H and J: Comparison of single CPCH and multiple CPCH, idle-random at 2 Msps

As can be seen from the table the multiple CPCH case performs significantly better than the single CPCH case. Note that the packet length in the multiple CPCH case is 1000 bytes whereas in the single CPCH case it is 480 bytes. This case outperforms the single CPCH channel with the recency method as well (Case I). Table G-11 refers to the idle-random method in case of single 2 Msps CPCH, 200 ms packet inter-arrival, 480 bytes messages; Table G-12 refers to the same methods but considering 4 CPCH @ 2Msps, 300 ms inter-arrival time, 1000 byte messages.

Table G-11: Single CPCH with 200 ms packet inter-arrival

\square	\square S1	D(un)	QD	AD	TD	MAC Coll
.56	.535	.23	.171	.0448	.0137	200,833
.768	.684	.97	.883	.0729	.0137	398,000

Table G-12: Multiple CPCH with 300 ms packet inter arrival

\square	S1	D(un)	QD	AD	TD	MAC Coll
.57	.61	.067	.02	.012	.035	6.35 %
.76	.71	.096	.045	.016	.035	14.6%
.82	.75	.104	.05	.019	.035	18.1%
.88	.76	.171	.115	.021	.035	20%
.93	.8	.242	.184	.023	.035	23%
.975	.81	.367	.28	.025	.035	25%

G.4 Discussion on idle-AICH and use of TFCI

As the packet inter-arrival time decreases, the throughput delay performance of all the CPCH channel selection algorithms degrades. At low packet inter-arrival times, the idle-random method clearly out-performs the recency method. The simple method performs worst in all cases. When the packet-inter-arrival time increases to 100-200 ms, then the recency method performs similar to the idle-random case. Note that at high packet inter-arrival times (very low channel loading), the throughput delay performance of all cases improves significantly. In reality, if we do not have fixed packet length and let the UE transmit the incoming packets from the higher layer midst the CPCH transmission, then the packet inter-arrival times will be higher values. By optimising the random-idle case with appropriate back-off mechanism and incorporating the impact of the discrepancies in the recency table, the random-idle case will perform better at high packet inter-arrival times as well. So, we propose adoption of use of idle-AICH to provide for more knowledge of the CPCH channel usage.

G.5 Recommended RRM Strategies

- Use the idle-AICH channel selection algorithm to improve the performance when the packet inter-arrival time is small.
- Use of TFCI is recommended so that the packet arrival process become less clustered and approach the Poisson statistics. This will ensure better throughput delay performance.

Annex H: Examples of RACH/PRACH Configuration

This appendix illustrates examples of RACH/PRACH configurations in a cell.

H.1 Principles of RACH/PRACH Configuration

In one cell, several RACHs and PRACHs may be configured by an operator, in order to meet the performance requirements in regard to the expected traffic volume. The model of RACH and PRACH described in [5] defines a one-to-one mapping between a certain RACH and a PRACH.

The RACHs mapped to the PRACHs may all employ the same Transport Format and Transport Format Combination Sets, respectively. It is however also possible that individual RACH Transport Format Sets are applied on each available RACH/PRACH. The parameters that define pairs of RACH and PRACH are specified in [9], in the information element "PRACH system information list".

The "PRACH system information list" IE defines sets of "PRACH system information", one for each pair of RACH and PRACH that shall be configured in a cell. The "PRACH system information list" IE is included in SIB 5 and SIB 6. The total number of configured RACH/PRACH pairs corresponds to the sum of PRACH system information multiplicity factors used in both SIB5 and SIB 6.

A PRACH could therefore be defined in a pragmatic way simply as a common uplink physical channel, which is indicated in system information. It is straightforward for the UE to count the indicated RACH/PRACH pairs, perform a selection and configure itself for accessing the selected channel. There are however some restrictions on the choice of parameters to be included in PRACH system information. Restrictions are especially due to the requirement that the PRACH receiver in the Node B must be capable to identify unambiguously on which PRACH a random access is received. This is necessary to perform the mapping of the decoded PRACH message part to the correct RACH transport channel associated with the PRACH. For complexity reasons it is furthermore a desired functionality that PRACH identification in FDD mode is completed in the preamble transmission phase in order to decode the PRACH message part, which follows the preamble, as generally there might be different transport format parameters defined on each RACH.

Taking into account the above requirements, the RACH/PRACH model allows to configure different PRACHs in the following two ways:

1. For each PRACH indicated in system information a different preamble scrambling code is employed in FDD and a different timeslot is employed in TDD. For each PRACH, sets of "available signatures" in FDD or "available channelisation codes" in TDD, and "available subchannel numbers" are defined in the "PRACH info (for RACH)" Information Element in [9]. Any PRACH with an individual scrambling code in FDD or individual timeslot in TDD may employ the complete or a subset of signatures in FDD or channelisation codes in TDD, and subchannels.
2. Two (or more) PRACHs indicated in system information use a common preamble scrambling code in FDD and common timeslot in TDD. In this case each PRACH shall employ a distinct (non-overlapping) set of "available signatures" in FDD or "available channelisation codes" in TDD, and "available subchannel numbers" in order to enable Node B to identify from the received random access signal which PRACH and respective RACH is used.

Figure H.1 for FDD and H.2 for TDD show examples of suitable RACH/PRACH configurations for one cell. The upper part of the figure illustrates the one-to-one mapping between a RACH and a PRACH. In FDD each RACH is specified via an individual Transport Format Set (TFS). The associated PRACH employs a Transport Format Combination Set (TFCS), with each TFC in the set corresponding to one specific TF of the RACH. In TDD each RACH/PRACH combination supports a single TF with the associated TFS. The maximum number of PRACH per cell is currently limited to 16. The maximum number of RACHs must be the same due to the one-to-one correspondence between a RACH and a PRACH.

With each PRACH, in FDD a scrambling code is associated, and in TDD a single timeslot is associated. [9] allows to address 16 different scrambling codes in FDD. Also, to each PRACH a set of "available subchannels" and "available signatures" in FDD or "available channelisation codes" in TDD is assigned.

For each PRACH a set of up to eight "PRACH partitions" can be defined for establishment of Access Service Classes (ASCs). A PRACH partition is defined as the complete or a subset of the "available signatures" in FDD or "available channelisation codes" in TDD, and "available subchannel numbers" defined for one PRACH. An ASC consists of a PRACH partition and a persistence value. PRACH partitions employed for ASC establishment may be overlapping (note that Figure H.1 and H2 only illustrates cases of non-overlapping PRACH partitions).

PRACH 0 and PRACH 1 in Figure H.1 employ the full set of PRACH subchannels and preamble signatures and are identified by using different preamble scrambling codes. Similarly in figure H.2 PRACH 0 & 1 employ the full set of PRACH subchannels and channelisation codes and are identified by using different timeslots.

PRACH 2 and PRACH 3 illustrate a configuration where a common scrambling code in FDD (figure H.1) and a common timeslot timeslot in TDD (figure H.2) but distinct (non-overlapping) partitions of "available subchannels" and "available signatures" in FDD and "available channelisation codes" in TDD are assigned. This configuration in FDD may e.g. be appropriate for establishment of two RACH/PRACH pairs, one with 10 and the other with 20 ms TTI.

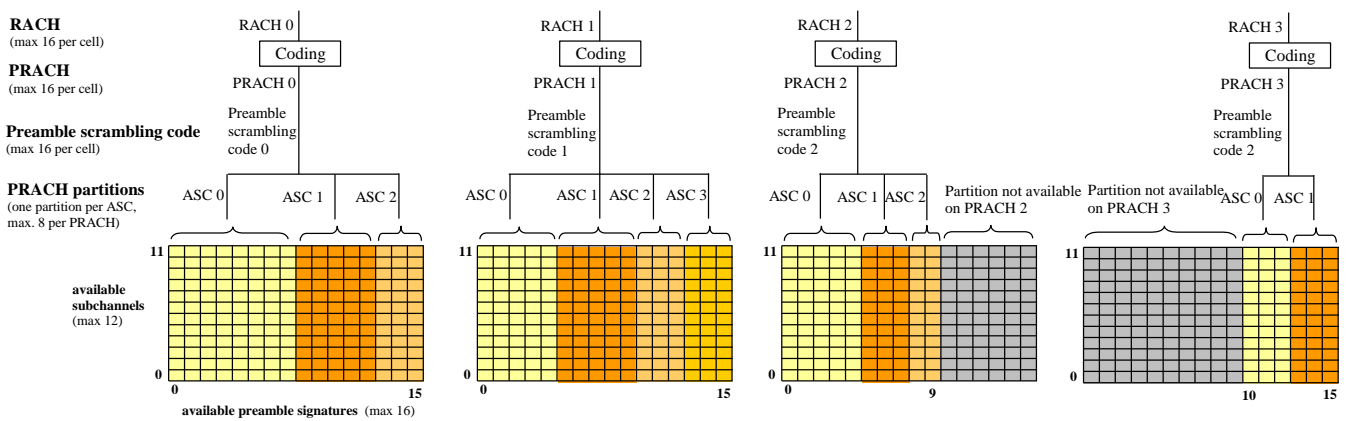

Figure H.1: Examples of FDD RACH/PRACH configurations in a cell

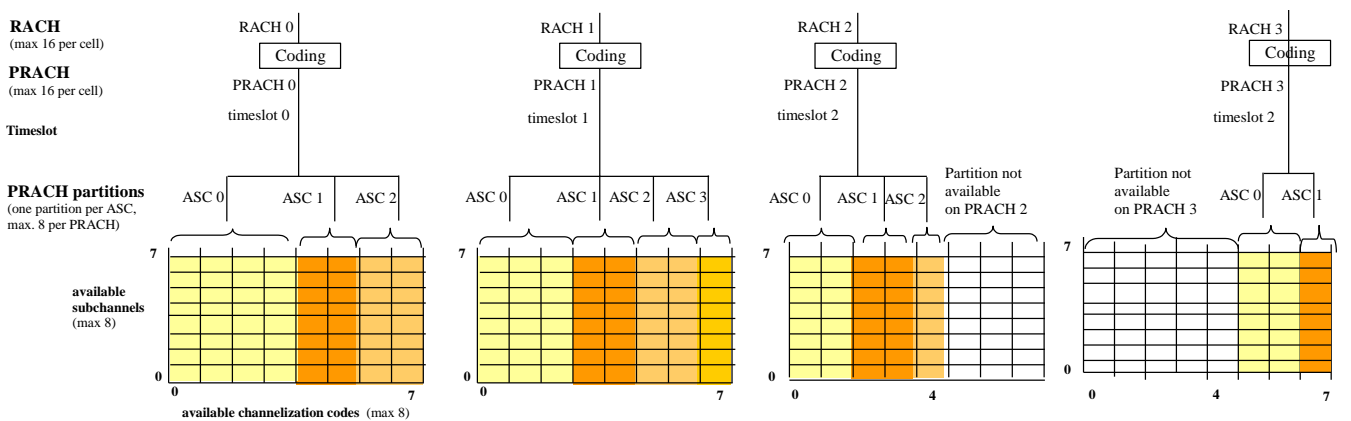

Figure H.2: Examples of TDD RACH/PRACH configurations in a cell

NOTE 1: ASC partitions by subchannel are possible but not shown.

NOTE 2: TDD example shows 8 subchannels. In TDD 1, 2, and 4 subchannels are also possible. Description of TDD subchannels can be found in [17].

Annex I: Example of PCPCH assignment with VCAM

This subclause illustrates an example of PCPCH assignment using the mapping rule specified in [9] for the Versatile Channel Assignment Method (VCAM) for the case that the number of PCPCHs, K , is larger than 16.

Table I-1 shows the mapping of pairs of AP signature/subchannel numbers and CA signature numbers to PCPCH indices k . In the shown example the number of minimum available spreading factors is set to $R = 2$, and the number of PCPCHs is $K=21$.

Table I-1: Example of PCPCH assignment with VCAM

PCPCH (k)	$A_0 = 128$			$A_1 = 256$			
0	AP ₀ (AP ₀), CA ₀	AP ₂ (AP ₁), CA ₇	AP ₁ (AP ₂), CA ₁₄	AP ₀ (AP ₃), CA ₀	AP ₁ (AP ₄), CA ₅	AP ₂ (AP ₅), CA ₁₀	AP ₃ (AP ₆), CA ₁₅
1	AP ₁ (AP ₁), CA ₀	AP ₀ (AP ₂), CA ₇	AP ₂ (AP ₀), CA ₁₄	AP ₁ (AP ₄), CA ₀	AP ₂ (AP ₅), CA ₅	AP ₃ (AP ₆), CA ₁₀	
2	AP ₂ (AP ₂), CA ₀	AP ₁ (AP ₀), CA ₇	AP ₀ (AP ₁), CA ₁₄	AP ₂ (AP ₅), CA ₀	AP ₃ (AP ₆), CA ₅	AP ₀ (AP ₃), CA ₁₁	
3	AP ₀ (AP ₀), CA ₁	AP ₂ (AP ₁), CA ₈	AP ₁ (AP ₂), CA ₁₅	AP ₃ (AP ₆), CA ₀	AP ₀ (AP ₃), CA ₆	AP ₁ (AP ₄), CA ₁₁	
4	AP ₁ (AP ₁), CA ₁	AP ₀ (AP ₂), CA ₈	AP ₂ (AP ₀), CA ₁₅	AP ₀ (AP ₃), CA ₁	AP ₁ (AP ₄), CA ₆	AP ₂ (AP ₅), CA ₁₁	
5	AP ₂ (AP ₂), CA ₁	AP ₁ (AP ₀), CA ₈	AP ₀ (AP ₁), CA ₁₅	AP ₁ (AP ₄), CA ₁	AP ₂ (AP ₅), CA ₆	AP ₃ (AP ₆), CA ₁₁	
6	AP ₀ (AP ₀), CA ₂	AP ₂ (AP ₁), CA ₉		AP ₂ (AP ₅), CA ₁	AP ₃ (AP ₆), CA ₆	AP ₀ (AP ₃), CA ₁₂	
7	AP ₁ (AP ₁), CA ₂	AP ₀ (AP ₂), CA ₉		AP ₃ (AP ₆), CA ₁	AP ₀ (AP ₃), CA ₇	AP ₁ (AP ₄), CA ₁₂	
8	AP ₂ (AP ₂), CA ₂	AP ₁ (AP ₀), CA ₉		AP ₀ (AP ₃), CA ₂	AP ₁ (AP ₄), CA ₇	AP ₂ (AP ₅), CA ₁₂	
9	AP ₀ (AP ₀), CA ₃	AP ₂ (AP ₁), CA ₁₀		AP ₁ (AP ₄), CA ₂	AP ₂ (AP ₅), CA ₇	AP ₃ (AP ₆), CA ₁₂	
10	AP ₁ (AP ₁), CA ₃	AP ₀ (AP ₂), CA ₁₀		AP ₂ (AP ₅), CA ₂	AP ₃ (AP ₆), CA ₇	AP ₀ (AP ₃), CA ₁₃	
11	AP ₂ (AP ₂), CA ₃	AP ₁ (AP ₀), CA ₁₀		AP ₃ (AP ₆), CA ₂	AP ₀ (AP ₃), CA ₈	AP ₁ (AP ₄), CA ₁₃	
12	AP ₀ (AP ₀), CA ₄	AP ₂ (AP ₁), CA ₁₁		AP ₀ (AP ₃), CA ₃	AP ₁ (AP ₄), CA ₈	AP ₂ (AP ₅), CA ₁₃	
13	AP ₁ (AP ₁), CA ₄	AP ₀ (AP ₂), CA ₁₁		AP ₁ (AP ₄), CA ₃	AP ₂ (AP ₅), CA ₈	AP ₃ (AP ₆), CA ₁₃	
14	AP ₂ (AP ₂), CA ₄	AP ₁ (AP ₀), CA ₁₁		AP ₂ (AP ₅), CA ₃	AP ₃ (AP ₆), CA ₈	AP ₀ (AP ₃), CA ₁₄	
15	AP ₀ (AP ₀), CA ₅	AP ₂ (AP ₁), CA ₁₂		AP ₃ (AP ₆), CA ₃	AP ₀ (AP ₃), CA ₉	AP ₁ (AP ₄), CA ₁₄	
16	AP ₁ (AP ₁), CA ₅	AP ₀ (AP ₂), CA ₁₂		AP ₀ (AP ₃), CA ₄	AP ₁ (AP ₄), CA ₉	AP ₂ (AP ₅), CA ₁₄	
17	AP ₂ (AP ₂), CA ₅	AP ₁ (AP ₀), CA ₁₂		AP ₁ (AP ₄), CA ₄	AP ₂ (AP ₅), CA ₉	AP ₃ (AP ₆), CA ₁₄	
18	AP ₀ (AP ₀), CA ₆	AP ₂ (AP ₁), CA ₁₃		AP ₂ (AP ₅), CA ₄	AP ₃ (AP ₆), CA ₉	AP ₀ (AP ₃), CA ₁₅	
19	AP ₁ (AP ₁), CA ₆	AP ₀ (AP ₂), CA ₁₃		AP ₃ (AP ₆), CA ₄	AP ₀ (AP ₃), CA ₁₀	AP ₁ (AP ₄), CA ₁₅	
20	AP ₂ (AP ₂), CA ₆	AP ₁ (AP ₀), CA ₁₃		AP ₀ (AP ₃), CA ₅	AP ₁ (AP ₄), CA ₁₀	AP ₂ (AP ₅), CA ₁₅	

NOTE:

- SF (A_0) = 128, Number of AP (S_0) = 3: Re-numbered AP0 = AP₀, AP1 = AP₁, AP2 = AP₂

- $SF(A_1) = 256$, Number of AP (S_1) = 4: Re-numbered AP3 = AP₀, AP4 = AP₁, AP5 = AP₂, AP6 = AP₃
- $P_0 = P_1 = 21$
- $T_0 = T_1 = 16$.
- In this example, $M_0 = 7$, $M_1 = 21$

Annex J: Examples of scheduling functions for HSDPA

This annex provides examples of HSDPA scheduling functions that combine both channel information and service requirements (i.e. "channel dependent" and "QoS aware" packet schedulers) for real-time / near real-time services, as described in clause 13.

J.1 Link adaptation

A link-adaptation algorithm can be used for the selection of suitable CQI to be assumed in transmission of each packet. In this example, the selected CQI is the highest that corresponds to BLER values not higher than 0.1, as described by the following expression:

$$CQI = \underset{i}{MAX} (\arg(BLER(CQI_i) \leq 0.1)) \quad (1)$$

In case of services with variable packet sizes, the RRM algorithm could map packets of variable size into variable length radio blocks (which depends on the CQI). For such a system the following actions are performed by the scheduler in order to map packets into radio blocks through ARQ processes:

1. CQI is selected according to the link adaptation algorithm;
2. Packet is prioritized according to the prioritization scheduling algorithm;
3. Scheduler calculates the number of transport blocks needed to transmit the packet, according to the expression (2)

$$NBlocks = \left\lceil \frac{PacketSize}{BlockSize(MCS_i)} \right\rceil \quad (2)$$

where $\lceil x \rceil$ means lowest integer higher or equal to x ;

4. An idle ARQ channel is selected to hold packets and the number of allocated transport blocks;

J.2 Priority scheduling functions

Different scheduling algorithms may be considered, according to the way the different parameters such as reliability in transmission, service requirements and number of attempted transmissions are weighted, in order to combine reliability in packet transmission of each user with upper layer service requirements.

For instance, a priority value can be calculated every TTI combining W_1 , W_2 and W_3 , where W_1 , W_2 and W_3 concern respectively to the reliability on block transmission, the service delay requirement and attempted transmissions.

Three possible examples of priority functions (Priority₁, Priority₂, and Priority₃) are reported below:

1. $Priority_1 = W_1(CQI, SIR)(W_2(packetTimeOut) + W_3(\#attempTx))$ (3)

2. $Priority_2 = W_1(CQI, SIR)(W_2(queueAvgTimeOut) + W_3(\#attempTx))$ (4)

3. $Priority_3 = W_1(CQI, SIR)(W_2(queueSize) + W_3(\#attempTx))$ (5)

Case 2 differs from case 1 by the fact that instead of actual individual packet delay value, the average delay of all packets in queue of one user is used. In case 3, instead of delay, the queue size in bits is used to prioritize the packet..

Further details on each functions are discussed below.

Reliability function, $W_1(CQI, SIR)$

The expected reliability is obtained by means of CQI, which reflects the SIR that the mobile experiences. For the transmission reliability three values are associated with a weight function: transmission with low probability of correct packet reception, transmission with reasonable probability of packet reception and transmission with high probability of correct packet reception. To distinguish between the three cases, the SIR target, and threshold values are assigned accordingly depending on the service requirements. The W_1 function in relation to the SIR is given by (6)

$$W_1(CQI, SIR) = \begin{cases} \sim 0 & \text{if } SIR < Trget \\ 1 & \text{if } Target < SIR < Trget + Threshold \\ 2 & \text{if } SIR > Trget + Threshold \end{cases} \quad (6)$$

Where Target and Threshold are functions of the considered video streaming service.

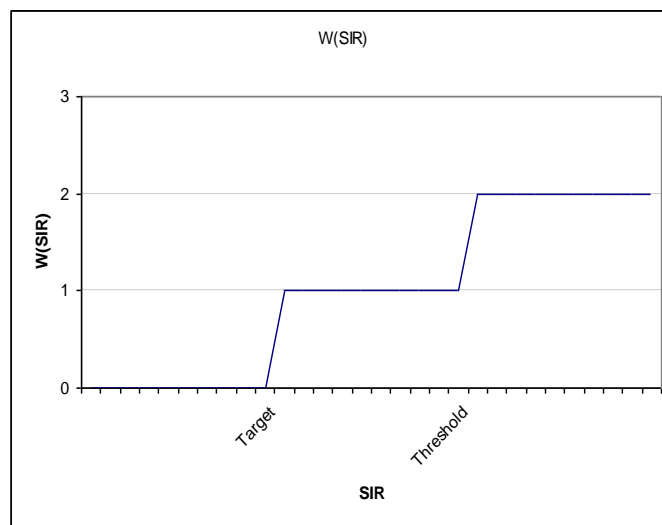

Figure J-1: Reliability function

The W_2 function – Time-out and Queue size functions

Time-out function

A time-out function is shown by Equation (7), and illustrated in Figure J-2. A value for the constant k is obtained, assuming that when time-out is reached the function will have the same value of as the reliability function for $SIR > Target + Threshold$.

$$W_2(TimeOut) = k(AllowableDelay - time_out) \quad (7)$$

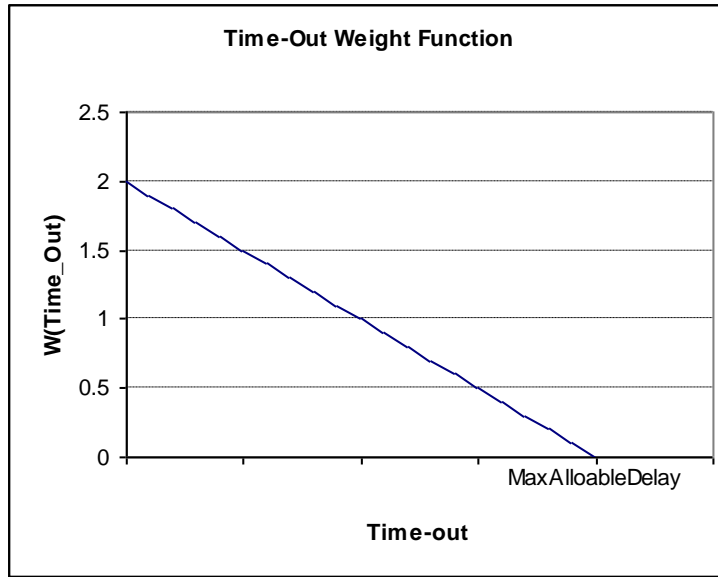

Figure J-2: Scheduling delay function

Queue size function

A queue size function is shown by Equation (8), and illustrated in Figure J-3. A value for the constant k is obtained, assuming that when maximum size of the queue/buffer is reached, the W_2 function will have the same value of as the reliability function for $SIR > Target + Threshold$.

$$W_2(queueSize) = k(queueSize) \tag{8}$$

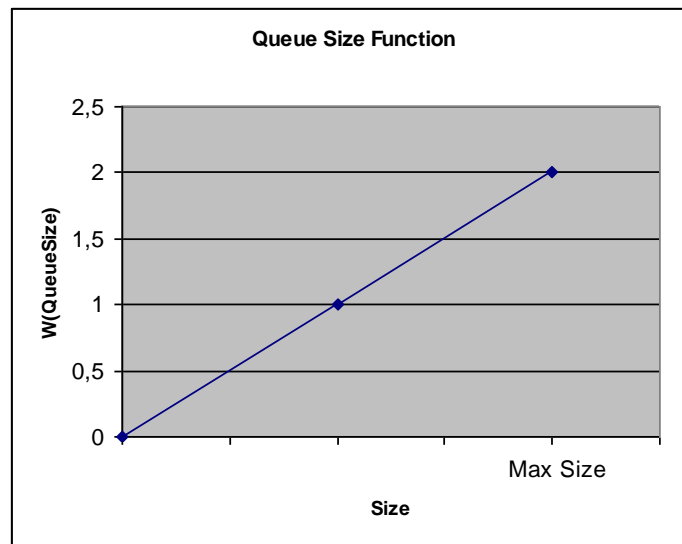

Figure J-3: Queue size function

Attempted Transmissions function, $W_3(attemptTx)$

The Attempted transmission function increases with the number of transmissions that the packet has experienced. The maximum number of transmissions will help to minimize the BLER results. After the third attempt the packet is discarded. Examples of values for the attempted transmissions are presented in (9) and graphically depicted in Figure J-4 for a maximum number of transmission equals to three. Three is the number for the maximum transmission attempts. However, other values can also be used.

$$W_3(AttemptTx) = \begin{cases} 0 & \text{if } AttemptTx = 0 \\ 1 & \text{if } AttemptTx = 1 \\ 2 & \text{if } AttemptTx = 2 \end{cases} \quad (9)$$

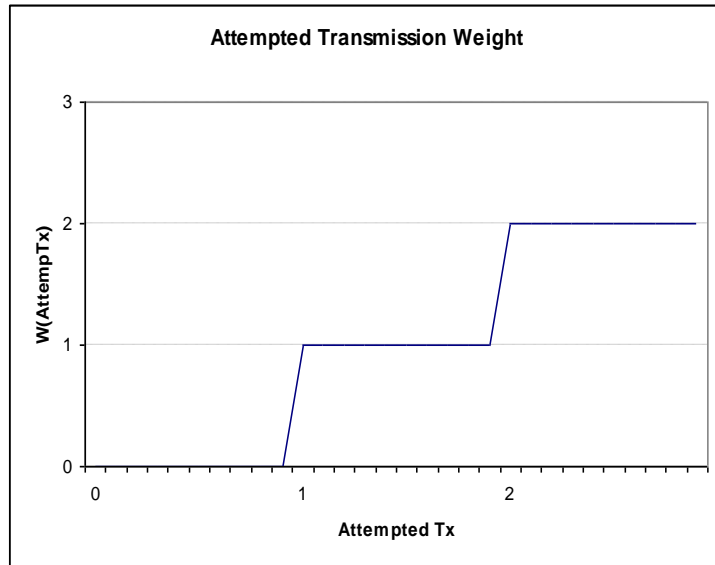

Figure J-4: Attempted transmissions function

Annex K: Change history

Change history							
Date	TSG #	TSG Doc.	CR	Rev	Subject/Comment	Old	New
12/1999	RP-06	RP-99661	-		Approved at TSG-RAN #6 and placed under Change Control	-	3.0.0
03/2000	RP-07	RP-00049	001		PDSCH code usage and signalling	3.0.0	3.1.0
06/2000	RP-08	RP-000228	003	1	Stage 2 description for Handover to UTRAN	3.1.0	3.2.0
09/2000	RP-09	RP-000366	004	2	Clarification on RRC security and capability information transfer during handover to UTRAN	3.2.0	3.3.0
	RP-09	RP-000366	006		Variable Rate Transmission	3.2.0	3.3.0
12/2000	RP-10	RP-000576	008		PRACH/RACH configuration	3.3.0	3.4.0
	RP-10	RP-000576	009	1	Example of VCAM mapping rule	3.3.0	3.4.0
	RP-10	RP-000576	010	1	Predefined configurations for R'99	3.3.0	3.4.0
	RP-10	RP-000576	011		Utilisation of compressed mode for BSIC reconfirmation	3.3.0	3.4.0
03/2001	RP-11	RP-010034	012	1	Principles of RACH/PRACH Configuration in TDD	3.4.0	3.5.0
	RP-11	RP-010034	013	1	Radio Bearer Control corrections	3.4.0	3.5.0
	RP-11	RP-010034	014		Correction to idle mode tasks	3.4.0	3.5.0
	RP-11	-	-		Upgrade to Release 4 - no technical change	3.5.0	4.0.0
09/2001	RP-13	RP-010552	016		Update of preconfiguration description	4.0.0	4.1.0
	RP-13	RP-010552	018		Alignment with 25.304	4.0.0	4.1.0
03/2002	RP-15	RP-020076	020		Clarification regarding the transfer of RRC information across interfaces other than Uu	4.1.0	4.2.0
	RP-15	RP-020076	022		Correction to TDD DCA Description	4.1.0	4.2.0
	RP-15	-	-		Upgrade to Release 5 - no technical change	4.2.0	5.0.0
09/2003	RP-20	RP-030496	023	1	UTRAN-GERAN handovers	5.0.0	5.1.0
	RP-20	RP-030496	024		Admission Control strategies in case of Handover	5.0.0	5.1.0
	RP-20	RP-030496	025		Example of congestion control strategies	5.0.0	5.1.0
12/2003	RP-22	RP-030627	027		Radio Resource handling of streaming traffic class PDP contexts	5.1.0	5.2.0
03/2004	RP-23	RP-040099	031		Corrections and alignment with core specifications. Upgrade to the "Release independent" status and creation of the Rel-6	5.2.0	6.0.0
04/2004	-	-	-		Correction of erroneous coversheet	6.0.0	6.0.1
06/2005	RP-28	RP-050307	0032		Feature Clean Up: Removal of SSDT	6.0.1	6.1.0
09/2005	RP-29	RP-050473	0033		PS handover to/from GERAN	6.1.0	6.2.0
03/2006	RP-31	RP-060083	0035		Examples of RRM strategies for HSDPA	6.2.0	6.3.0
	RP-31	RP-060090	0034		Removal of DSCH	6.2.0	6.3.0
	RP-31	RP-060090	0036		Clarification regarding ROHC context transfer	6.2.0	6.3.0
12/2006	RP-34	RP-060724	0037		Introduction of inter-RAT DTM Handover	6.3.0	7.0.0
03/2007	RP-35	RP-070151	0042		Examples of RRM strategies for MBMS	7.0.0	7.1.0
	RP-35	RP-070173	0043		Introduction of GAN CS Handover and PS Handover	7.0.0	7.1.0