

# 3GPP TR 25.912 V11.0.0 (2012-09)

---

*Technical Report*

## **3rd Generation Partnership Project; Technical Specification Group Radio Access Network; Feasibility study for evolved Universal Terrestrial Radio Access (UTRA) and Universal Terrestrial Radio Access Network (UTRAN) (Release 11)**



The present document has been developed within the 3<sup>rd</sup> Generation Partnership Project (3GPP™) and may be further elaborated for the purposes of 3GPP.

The present document has not been subject to any approval process by the 3GPP Organizational Partners and shall not be implemented. This Specification is provided for future development work within 3GPP only. The Organizational Partners accept no liability for any use of this Specification. Specifications and reports for implementation of the 3GPP™ system should be obtained via the 3GPP Organizational Partners' Publications Offices.

---

---

Keywords

UMTS, radio

**3GPP**

---

Postal address

---

3GPP support office address

---

650 Route des Lucioles - Sophia Antipolis  
Valbonne - FRANCE  
Tel.: +33 4 92 94 42 00 Fax: +33 4 93 65 47 16

---

Internet

<http://www.3gpp.org>

---

**Copyright Notification**

No part may be reproduced except as authorized by written permission.  
The copyright and the foregoing restriction extend to reproduction in all media.

© 2012, 3GPP Organizational Partners (ARIB, ATIS, CCSA, ETSI, TTA, TTC).  
All rights reserved.

UMTS™ is a Trade Mark of ETSI registered for the benefit of its members  
3GPP™ is a Trade Mark of ETSI registered for the benefit of its Members and of the 3GPP Organizational Partners  
LTE™ is a Trade Mark of ETSI currently being registered for the benefit of its Members and of the 3GPP Organizational Partners  
GSM® and the GSM logo are registered and owned by the GSM Association

# Contents

Foreword .....	6
1 Scope .....	7
2 References.....	7
3 Definitions, symbols and abbreviations .....	7
3.1 Definitions .....	7
3.2 Symbols.....	7
3.3 Abbreviations.....	8
4 Introduction .....	9
5 Deployment scenario.....	10
6 Radio interface protocol architecture for evolved UTRA.....	10
6.1 User plane .....	12
6.2 Control plane .....	12
7 Physical layer for evolved UTRA.....	13
7.1 Downlink transmission scheme.....	13
7.1.1 Basic transmission scheme based on OFDMA .....	13
7.1.1.1 Basic parameters .....	13
7.1.1.1.1 Modulation scheme .....	14
7.1.1.2 Multiplexing including reference-signal structure .....	14
7.1.1.2.1 Downlink data multiplexing.....	14
7.1.1.2.2 Downlink reference-signal structure .....	14
7.1.1.2.3 Downlink L1/L2 Control Signaling.....	14
7.1.1.3 MIMO and transmit diversity .....	15
7.1.1.4 MBMS .....	15
7.1.2 Physical layer procedure.....	15
7.1.2.1 Scheduling.....	15
7.1.2.2 Link adaptation.....	16
7.1.2.3 HARQ.....	16
7.1.2.4 Cell search.....	16
7.1.2.5 Inter-cell interference mitigation.....	17
7.1.3 Physical layer measurements .....	17
7.1.3.1 UE measurements .....	17
7.1.3.1.1 Measurements for Scheduling .....	17
7.1.3.1.1.1 Channel Quality Measurements .....	17
7.1.3.1.1.2 Measurements for Interference Coordination/Management .....	18
7.1.3.1.2 Measurements for Mobility .....	18
7.1.3.1.2.1 Intra-frequency neighbour measurements .....	18
7.1.3.1.2.2 Inter-frequency neighbour measurements .....	18
7.1.3.1.2.3 Inter RAT measurements .....	18
7.1.3.1.2.4 Measurement gap control.....	18
7.2 Uplink transmission scheme .....	18
7.2.1 Basic transmission scheme .....	18
7.2.1.1 Modulation scheme .....	19
7.2.1.2 Multiplexing including reference signal structure .....	19
7.2.1.2.1 Uplink data multiplexing .....	19
7.2.1.2.2 Uplink reference-signal structure.....	20
7.2.1.2.3 Multiplexing of L1/L2 control signaling .....	20
7.2.1.2.4 Uplink L1/L2 Control Signalling.....	20
7.2.1.3 MIMO .....	21
7.2.1.4 Power De-rating Reduction.....	21
7.2.2 Physical channel procedure .....	21
7.2.2.1 Random access procedure .....	21
7.2.2.1.1 Non-synchronized random access.....	21
7.2.2.1.1.1 Power control for non-synchronized random access.....	21

7.2.2.1.2	Synchronized random access .....	21
7.2.2.2	Scheduling .....	21
7.2.2.3	Link adaptation .....	22
7.2.2.4	Power control .....	22
7.2.2.5	HARQ .....	22
7.2.2.6	Uplink timing control .....	22
7.2.2.7	Inter-cell interference mitigation .....	22
8	Layer 2 and RRC evolution for evolved UTRA .....	23
8.1	MAC sublayer .....	24
8.1.1	Services and functions .....	24
8.1.2	Logical channels .....	24
8.1.2.1	Control channels .....	25
8.1.2.2	Traffic channels .....	25
8.1.3	Mapping between logical channels and transport channels .....	25
8.1.3.1	Mapping in Uplink .....	26
8.1.3.2	Mapping in downlink .....	26
8.2	RLC sublayer .....	26
8.3	PDCP sublayer .....	27
8.4	RRC .....	27
8.4.1	Services and functions .....	27
8.4.2	RRC protocol states & state transitions .....	28
9	Architecture for evolved UTRAN .....	29
9.1	Evolved UTRAN architecture .....	29
9.2	Functional split .....	29
9.3	Interfaces .....	30
9.3.1	S1 interface .....	30
9.3.1.1	Definition .....	30
9.3.1.2	S1-C RNL protocol functions .....	30
9.3.1.3	S1-U RNL protocol functions .....	30
9.3.1.4	S1-X2 similarities .....	30
9.3.2	X2 interface .....	30
9.3.2.1	Definition .....	30
9.3.2.2	X2-C RNL Protocol Functions .....	31
9.3.2.3	X2-U RNL Protocol Functions .....	31
9.4	Intra-LTE-access-system mobility .....	31
9.4.1	Intra-LTE-access-system mobility support for UE in LTE_IDLE .....	31
9.4.2	Intra LTE-Access-System Mobility Support for UE in LTE_ACTIVE .....	31
9.4.2.1	Description of Intra-LTE-Access Mobility Support for UEs in LTE_ACTIVE .....	31
9.4.2.2	Solution for Intra-LTE-Access Mobility Support for UEs in LTE_ACTIVE .....	31
9.4.2.2.1	C-plane handling: .....	31
9.4.2.2.2	U-plane handling .....	33
9.5	Inter 3GPP access system mobility .....	33
9.5.1	Inter 3GPP access system mobility in Idle state .....	33
9.5.2	Inter 3GPP access system mobility handover .....	33
9.6	Resource establishment and QoS signalling .....	33
9.6.1	QoS concept and bearer service architecture .....	33
9.6.2	Resource establishment and QoS signalling .....	33
9.7	Paging and C-plane establishment .....	35
9.8	Evaluations on for E-UTRAN architecture and migration .....	35
9.9	Support of roaming restrictions in LTE_ACTIVE .....	35
10	RF related aspects of evolved UTRA .....	36
10.1	Scalable bandwidth .....	36
10.2	Spectrum deployment .....	36
11	Radio resource management aspects of evolved UTRA .....	37
11.1	Introduction .....	37
11.2	Definition and description of RRM functions .....	37
11.2.1	Radio Bearer Control (RBC) .....	37
11.2.2	Radio Admission Control (RAC) .....	37
11.2.3	Connection Mobility Control (CMC) .....	37

11.2.4	Packet Scheduling (PSC) .....	38
11.2.5	Inter-cell Interference Coordination (ICIC) .....	38
11.2.6	Load Balancing (LB) .....	38
11.2.7	Inter-RAT Radio Resource Management .....	38
11.3	RRM architecture in LTE .....	38
11.4	Support of load sharing and policy management across different Radio Access Technologies (RATs) .....	39
12	System and terminal complexity .....	39
12.1	Over all system complexity .....	39
12.2	Physical layer complexity .....	39
12.3	UE complexity .....	40
13	Performance assessments .....	41
13.1	Peak data rate .....	41
13.2	C-plane latency .....	42
13.2.1	FDD frame structure .....	43
13.2.2	TDD frame structure type 1 .....	44
13.2.3	TDD frame structure type 2 .....	46
13.3	U-plane latency .....	46
13.3.1	FDD frame structure .....	47
13.3.2	TDD frame structure type 1 .....	48
13.3.3	TDD frame structure type 2 .....	49
13.4	User throughput .....	50
13.4.1	Fulfilment of uplink user-throughput targets .....	50
13.4.1.1	Initial performance evaluation .....	50
13.4.1.2	UL user throughput performance evaluation .....	50
13.4.2	Fulfilment of downlink user-throughput targets .....	51
13.4.2.0	Initial performance evaluation .....	51
13.4.2.1	Fulfilment of downlink user-throughput targets by enhancement techniques .....	51
13.4.2.1.1	Performance Enhancement by Additional Transmit Antennas: 4 Transmit Antennas .....	52
13.4.2.2	DL user throughput performance evaluation .....	52
13.5	Spectrum efficiency .....	53
13.5.1	Fulfilment of uplink spectrum-efficiency target .....	53
13.5.1.1	Initial performance evaluation .....	53
13.5.1.2	UL spectrum efficiency performance evaluation .....	53
13.5.2	Fulfilment of downlink spectrum-efficiency target .....	54
13.5.2.0	Initial performance evaluation .....	54
13.5.2.1	Fulfilment of downlink spectrum-efficiency targets by enhancement techniques .....	54
13.5.2.2	DL spectrum efficiency performance evaluation .....	54
13.6	Mobility .....	55
13.6.1	Features supporting various mobile velocities .....	55
13.6.2	Assessment on U-plane interruption time during handover .....	56
13.6.3	Means to minimise packet loss during handover .....	58
13.7	Coverage .....	58
13.8	Support for point to multipoint transmission .....	59
13.8.1	Initial performance evaluation .....	60
13.8.2	MBSFN performance evaluation .....	60
13.9	Network synchronisation .....	60
13.10	Co-existence and inter-working with 3GPP RAT .....	61
13.11	General requirements .....	61
13.11.1	Cost related requirements .....	61
13.11.2	Service related requirements .....	62
13.12	VoIP performance evaluation .....	62
14	Conclusions and Recommendations .....	62
14.1	Conclusions .....	62
14.2	Recommendations .....	63
<b>Annex A (informative):</b>	<b>Change History .....</b>	<b>64</b>

---

## Foreword

This Technical Report has been produced by the 3<sup>rd</sup> Generation Partnership Project (3GPP).

The contents of the present document are subject to continuing work within the TSG and may change following formal TSG approval. Should the TSG modify the contents of the present document, it will be re-released by the TSG with an identifying change of release date and an increase in version number as follows:

Version x.y.z

where:

- x the first digit:
  - 1 presented to TSG for information;
  - 2 presented to TSG for approval;
  - 3 or greater indicates TSG approved document under change control.
- y the second digit is incremented for all changes of substance, i.e. technical enhancements, corrections, updates, etc.
- z the third digit is incremented when editorial only changes have been incorporated in the document.

---

# 1 Scope

This present document is the technical report for the study item "Evolved UTRA and UTRAN" [1]. The objective of the study item is to develop a framework for the evolution of the 3GPP radio -access technology towards a high-data-rate, low-latency and packet-optimized radio access technology.

---

# 2 References

The following documents contain provisions which, through reference in this text, constitute provisions of the present document.

- References are either specific (identified by date of publication, edition number, version number, etc.) or non-specific.
- For a specific reference, subsequent revisions do not apply.
- For a non-specific reference, the latest version applies. In the case of a reference to a 3GPP document (including a GSM document), a non-specific reference implicitly refers to the latest version of that document *in the same Release as the present document*.

- [1] [3GPP TD RP-040461](#): "Proposed Study Item on Evolved UTRA and UTRAN".
- [2] [3GPP TR 25.814](#): "Physical Layer Aspects for Evolved UTRA"
- [3] [3GPP TR 23.882](#): "3GPP System Architecture Evolution: Report on Technical Options and Conclusions"
- [4] [3GPP TR 25.913](#): "Requirements for Evolved UTRA (E-UTRA) and Evolved UTRAN (E-UTRAN)"
- [5] [3GPP TR 25.813](#): "Evolved UTRA (E-UTRA) and Evolved UTRAN (E-UTRAN): Radio Interface Protocol Aspects."
- [6] [3GPP TD RP-060292](#) R3.018: "E-UTRA and E-UTRAN; Radio access architecture and interfaces."
- [7] Recommendation ITU-R SM.329-10: "Unwanted emissions in the spurious domain"
- [8] [3GPP TD R4-060660](#): "E-UTRA Radio Technology Aspects V0.1.0", NTT DoCoMo
- [9] [3GPP TD R4-051146](#): "Some operators requirements for prioritisation of performance requirements work in RAN WG4"
- [10] 3GPP TD R1-070674: "LTE physical layer framework for performance verification"  
Orange, China Mobile, KPN, NTT DoCoMo, Sprint, T-Mobile, Vodafone, Telecom Italia.

---

# 3 Definitions, symbols and abbreviations

## 3.1 Definitions

void

## 3.2 Symbols

void

### 3.3 Abbreviations

For the purposes of the present document, the following abbreviations apply:

ACK	Acknowledgement
ACLR	Adjacent Channel Leakage Ratio
aGW	Access Gateway
AM	Acknowledge Mode
ARQ	Automatic Repeat Request
AS	Access Stratum
BCCH	Broadcast Control Channel
BCH	Broadcast Channel
C/I	Carrier-to-Interference Power Ratio
CAZAC	Constant Amplitude Zero Auto-Correlation
CMC	Connection Mobility Control
CP	Cyclic Prefix
C-plane	Control Plane
CQI	Channel Quality Indicator
CRC	Cyclic Redundancy Check
DCCH	Dedicated Control Channel
DL	Downlink
DRX	Discontinuous Reception
DTCH	Dedicated Traffic Channel
DTX	Discontinuous Transmission
eNB	E-UTRAN NodeB
EPC	Evolved Packet Core
E-UTRA	Evolved UTRA
E-UTRAN	Evolved UTRAN
FDD	Frequency Division Duplex
FDM	Frequency Division Multiplexing
GERAN	GSM EDGE Radio Access Network
GNSS	Global Navigation Satellite System
GSM	Global System for Mobile communication
HARQ	Hybrid ARQ
HO	Handover
HSDPA	High Speed Downlink Packet Access
ICIC	Inter-Cell Interference Coordination
IP	Internet Protocol
LB	Load Balancing
LCR	Low Chip Rate
LTE	Long Term Evolution
MAC	Medium Access Control
MBMS	Multimedia Broadcast Multicast Service
MCCH	Multicast Control Channel
MCS	Modulation and Coding Scheme
MIMO	Multiple Input Multiple Output
MME	Mobility Management Entity
MTCH	MBMS Traffic Channel
NACK	Non-Acknowledgement
NAS	Non-Access Stratum
OFDM	Orthogonal Frequency Division Multiplexing
OFDMA	Orthogonal Frequency Division Multiple Access
PA	Power Amplifier
PAPR	Peak-to-Average Power Ratio
PCCH	Paging Control Channel
PDCP	Packet Data Convergence Protocol
PDU	Packet Data Unit
PHY	Physical layer
PLMN	Public Land Mobile Network
PRB	Physical Resource Block
PSC	Packet Scheduling
QAM	Quadrature Amplitude Modulation



QoS	Quality of Service
RAC	Radio Admission Control
RACH	Random Access Channel
RAT	Radio Access Technology
RB	Radio Bearer
RBC	Radio Bearer Control
RF	Radio Frequency
RLC	Radio Link Control
RNL	Radio Network Layer
ROHC	Robust Header Compression
RRC	Radio Resource Control
RRM	Radio Resource Management
RU	Resource Unit
S1	interface between eNB and aGW
S1-C	S1-Control plane
S1-U	S1-User plane
SAE	System Architecture Evolution
SAP	Service Access Point
SC-FDMA	Single Carrier – Frequency Division Multiple Access
SCH	Synchronization Channel
SDMA	Spatial Division Multiple Access
SDU	Service Data Unit
SFN	Single Frequency Network
TA	Tracking Area
TB	Transport Block
TCP	Transmission Control Protocol
TDD	Time Division Duplex
TM	Transparent Mode
TNL	Transport Network Layer
TTI	Transmission Time Interval
UE	User Equipment
UL	Uplink
UM	Un-acknowledge Mode
UMTS	Universal Mobile Telecommunication System
UPE	User Plane Entity
U-plane	User plane
UTRA	Universal Terrestrial Radio Access
UTRAN	Universal Terrestrial Radio Access Network
VRB	Virtual Resource Block
X2	interface between eNBs
X2-C	X2-Control plane
X2-U	X2-User plane

---

## 4 Introduction

At the 3GPP TSG RAN #26 meeting, the SI description on "Evolved UTRA and UTRAN" was approved [1].

The justification of the study item was, that with enhancements such as HSDPA and Enhanced Uplink, the 3GPP radio-access technology will be highly competitive for several years. However, to ensure competitiveness in an even longer time frame, i.e. for the next 10 years and beyond, a long-term evolution of the 3GPP radio-access technology needs to be considered.

Important parts of such a long-term evolution include reduced latency, higher user data rates, improved system capacity and coverage, and reduced cost for the operator. In order to achieve this, an evolution of the radio interface as well as the radio network architecture should be considered.

Considering a desire for even higher data rates and also taking into account future additional 3G spectrum allocations the long-term 3GPP evolution should include an evolution towards support for wider transmission bandwidth than 5 MHz. At the same time, support for transmission bandwidths of 5MHz and less than 5MHz should be investigated in order to allow for more flexibility in whichever frequency bands the system may be deployed

---

## 5 Deployment scenario

A very large set of scenarios are foreseen, as stated in 25.913 [4]:

- Standalone deployment scenario: In this scenario the operator is deploying E-UTRAN either with no previous network deployed in the area or it could be deployed in areas where there is existing UTRAN/GERAN coverage but for any reason there is no requirement for interworking with UTRAN/GERAN (e.g. standalone wireless broadband application).
- Integrating with existing UTRAN and/or GERAN deployment scenario: In this scenario it is assumed that the operator is having either a UTRAN and/or a GERAN network deployed with full or partial coverage in the same geographical area. It is assumed that the GERAN and UTRAN networks respectively can have differently levels of maturity.

In order to enable the large number of possibilities, E-UTRAN will support the following:

- 1) shared networks, both in initial selection and in mobile-initiated (controlled by system broadcast) and network-initiated/–controlled mobility.
- 2) high-velocity and nomadic mobiles. Mobility mechanisms include a handover mechanism with short latency, short interruption and minimizing of data losses (when the user has high data activity). Hence both high mobile velocities and Conversational QoS can be supported (as elaborated in 13.6).
- 3) various cell sizes and radio environments. The radio aspects are analyzed in chapter 10, but the specified mobility mechanisms are deemed adequate to support different cell sizes (also mixed) and both planned or adhoc deployments.  
**Note: ad hoc deployment inherently does not support high user QoS classes.**
- 4) co-operation with legacy systems as required in 25.913 chapter 8.4. In particular Handover to and from GERAN and UTRAN is supported. Handover can be triggered by combinations of radio quality and requested bearer quality. This capability enables all combinations of E-UTRAN and GERAN/UTRAN coverage, ranging from full to partial coverage, overlapping to adjacent coverage and ranging from co-siting (with re-use of equipment) to separate sites for LTE, as required in 25.913 chapter 8.3. It also enables operator control of RAT and QoS selection per user.
- 5) The requirement on efficiency is to a large extent determined by radio functions (described in chapters 9 and 10, analyzed in chapter 13). However, the designed mobility procedures are (for the intra-E-UTRAN case) potentially considerably faster than the ones in legacy systems and can thus be considered to support the requirement on efficiency (as described in detail in 13.6.2).

E-UTRAN also supports the requirements of:

- 6) Simplicity, due to only one type of node.
- 7) Low user data delay, due to low number of nodes in the data path

E-UTRAN shall support IP transport networks and all data link options. E-UTRAN will use separated RNL and TNL QoS. This permits co-use of existing transport networks.

---

## 6 Radio interface protocol architecture for evolved UTRA

The E-UTRAN consists of eNBs, providing the E-UTRA U-plane (RLC/MAC/PHY) and C-plane (RRC) protocol terminations towards the UE. The eNBs interface to the aGW via the S1 [5].

Figure 6.1 below gives an overview of the E-UTRAN architecture where yellow-shaded boxes depict the logical nodes, white boxes depict the functional entities of the C-plane, and blue boxes depict the functional entities of the U-plane.

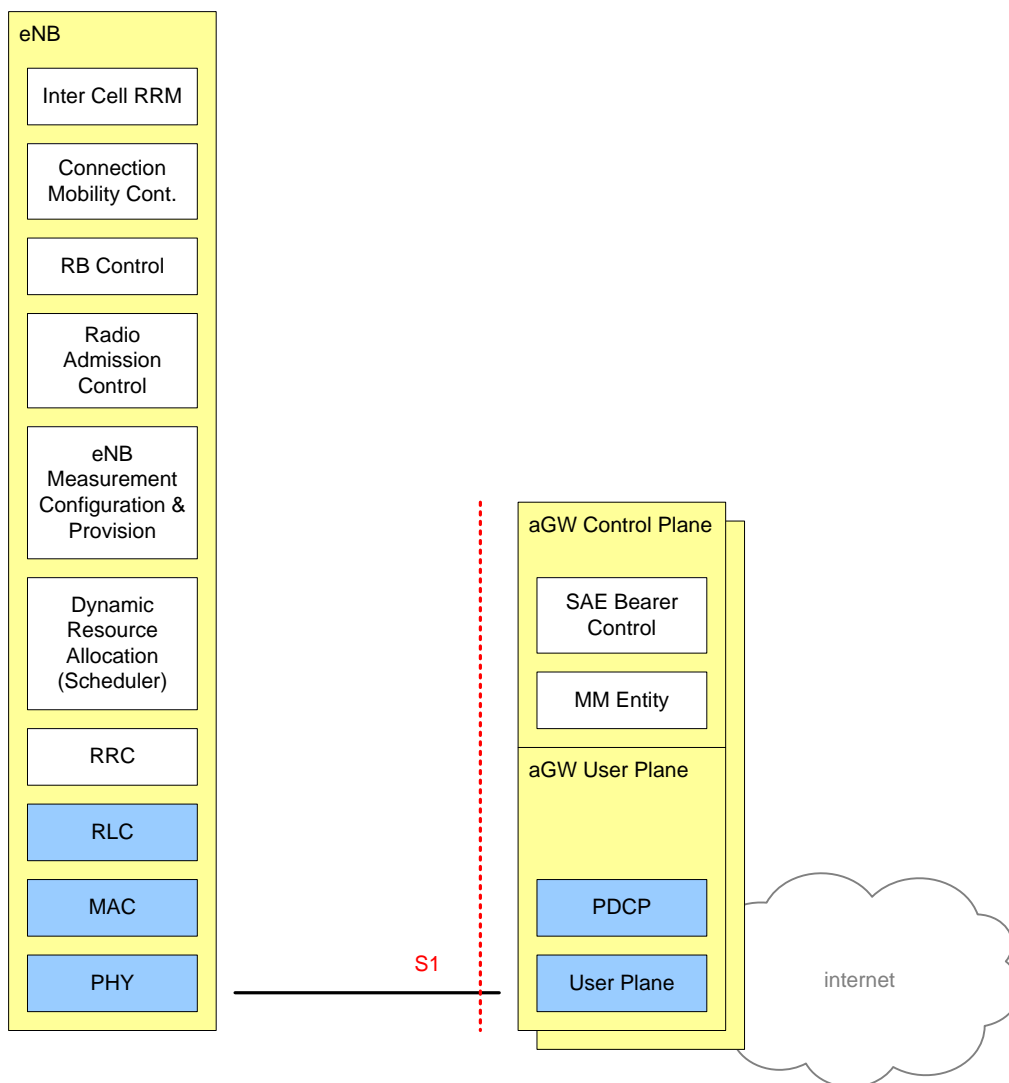

**Figure 6.1: E-UTRAN Architecture**

The functions hosted by the eNB are:

- Selection of aGW at attachment;
- Routing towards aGW at RRC activation;
- Scheduling and transmission of paging messages;
- Scheduling and transmission of BCCH information;
- Dynamic allocation of resources to UEs in both uplink and downlink;
- The configuration and provision of eNB measurements;
- Radio Bearer Control;
- Radio Admission Control;
- Connection Mobility Control in LTE\_ACTIVE state.

The functions hosted by the aGW are:

- Paging origination;
- LTE\_IDLE state management;

- Ciphering of the U-plane;
- PDCP;
- SAE Bearer Control (see [3]);
- Ciphering and integrity protection of NAS signalling.

## 6.1 User plane

Figure 6.2 below shows the U-plane protocol stack for E-UTRAN, where:

- RLC and MAC sublayers (terminated in eNB on the network side) perform the functions listed in clause 8, e.g.:
  - Scheduling;
  - ARQ;
  - HARQ.
- PDCP sublayer (terminated in aGW on the network side) performs for the U-plane the functions listed in clause 8, e.g.:
  - Header Compression;
  - Integrity Protection (to be determined during WI phase)
  - Ciphering.

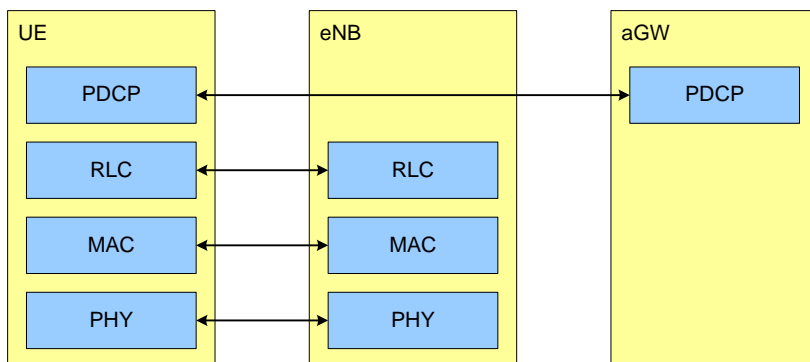

**Figure 6.2: U-plane protocol stack**

## 6.2 Control plane

Figure 6.3 below shows the C-plane protocol stack for E-UTRAN. The following working assumptions apply:

- RLC and MAC sublayers (terminated in eNB on the network side) perform the same functions as for the U-plane;
- RRC (terminated in eNB on the network side) performs the functions listed in clause 8, e.g.:
  - Broadcast;
  - Paging;
  - RRC connection management;
  - RB control;
  - Mobility functions;
  - UE measurement reporting and control.

- PDCP sublayer (terminated in aGW on the network side) performs for the C-plane the functions listed in clause 8, e.g.:
  - Integrity Protection;
  - Ciphering.
- NAS (terminated in aGW on the network side) performs among other things:
  - SAE bearer management;
  - Authentication;
  - Idle mode mobility handling;
  - Paging origination in LTE\_IDLE;
  - Security control for the signalling between aGW and UE, and for the U-plane.

NOTE: The NAS control protocol is not covered by the scope of this TR and is only mentioned for information.

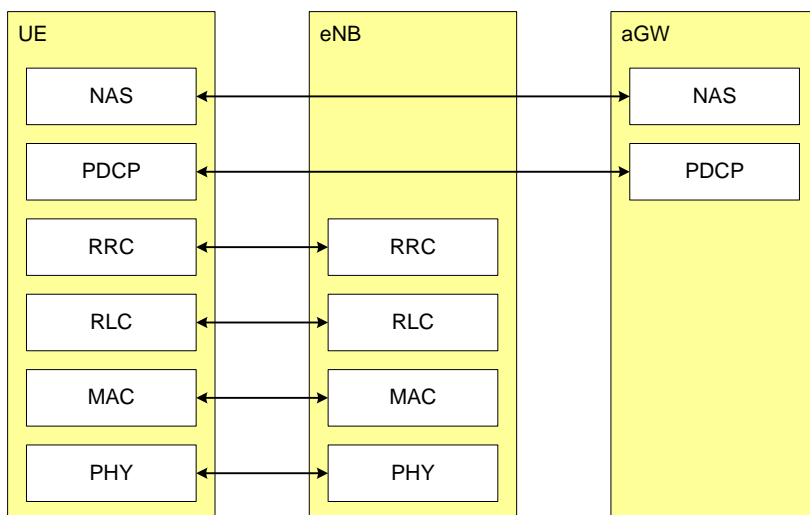

Figure 6.3: C-plane protocol stack

## 7 Physical layer for evolved UTRA

Supported bandwidths are 1.25MHz, 1.6MHz, 2.5MHz, 5MHz, 10MHz, 15MHz, and 20MHz.

Note: 1.6 MHz has been introduced with spectrum compatibility with LCR-TDD in mind.

### 7.1 Downlink transmission scheme

For both FDD and TDD, the downlink transmission scheme is based on OFDMA. Each 10 ms radio frame is divided into 10 equally sized sub-frames. In addition, for coexistence with LCR-TDD, a frame structure according to [2], clause 6.2.1.1.1, is also supported when operating E-UTRA in TDD mode. Channel-dependent scheduling and link adaptation can operate on a sub-frame level.

#### 7.1.1 Basic transmission scheme based on OFDMA

##### 7.1.1.1 Basic parameters

The downlink transmission scheme is based on conventional OFDM using a cyclic prefix. Information about the basic downlink parameters for operation in both paired and unpaired spectrum are given in [2] clause 7.1.1. For operation in

unpaired spectrum with these parameters (generic frame structure), idle symbols are included at DL/UL switching points and the idle period, required in the Node B at UL/DL switching points, is created by timing advance means. Note that, for operation in unpaired spectrum there is also an additional numerology, compatible with LCR-TDD, see [2].

The sub-carrier spacing is constant regardless of the transmission bandwidth. To allow for operation in differently sized spectrum allocations, the transmission bandwidth is instead varied by varying the number of OFDM sub-carriers.

#### 7.1.1.1.1 Modulation scheme

Supported downlink data-modulation schemes are QPSK, 16QAM, and 64QAM.

#### 7.1.1.2 Multiplexing including reference-signal structure

##### 7.1.1.2.1 Downlink data multiplexing

The channel-coded, interleaved, and data-modulated information [Layer 3 information] is mapped onto OFDM time/frequency symbols. The OFDM symbols are organized into a number of *physical* resource blocks (PRB) consisting of a number of consecutive sub-carriers for a number of consecutive OFDM symbols. The granularity of the resource allocation is matched to the expected minimum payload.

The frequency and time allocations to map information for a certain UE to resource blocks are determined by the Node B scheduler, see Clause 7.1.2.1 (time/frequency-domain channel-dependent scheduling). The channel-coding rate and the modulation scheme are also determined by the Node B scheduler and also depend on the reported CQI (time/frequency-domain link adaptation). Both block-wise transmission (localized) and transmission on non-consecutive (scattered, distributed) sub-carriers are supported. To describe this, the notion of a *virtual* resource block (VRB) is introduced. A virtual resource block has the following attributes:

- Size, measured in terms of time-frequency resource
- Type, which can be either 'localized' or 'distributed'
- Distributed VRBs are mapped onto the PRBs in a distributed manner. Localized VRBs are mapped onto the PRBs in a localized manner.

The multiplexing of localized and distributed transmissions within one sub-frame is accomplished by FDM.

##### 7.1.1.2.2 Downlink reference-signal structure

The downlink reference signal(s) can be used for at least

- Downlink-channel-quality measurements
- Downlink channel estimation for coherent demodulation/detection at the UE
- Cell search and initial acquisition

The basic downlink reference-signal structure consists of known *reference symbols* transmitted in known positions within the OFDM time/frequency grid. Reference symbols (a.k.a. "*First reference symbols*") are located in the first OFDM symbol of every sub-frame assigned for downlink transmission. This is valid for both FDD and TDD as well as for both long and short CP. Additional reference symbols (a.k.a. "*Second reference symbols*") are located in the third last OFDM symbol of every sub-frame assigned for downlink transmission. This is the baseline for both FDD and TDD as well as for both long and short CP. See [2] clause 7.1.1.2.2 for more details.

Orthogonality between reference signals of different TX antennas of the same cell/beam is created by means of FDM. This implies that the reference-signal structure with different antenna-specific frequency shifts is valid for each antenna. The reference signals of different cells/beams belonging to the same Node B are orthogonal to each other.

##### 7.1.1.2.3 Downlink L1/L2 Control Signaling

The downlink outband control signaling consists of

- scheduling information for downlink data transmission,
- scheduling grant for uplink transmission, and

- ACK/NAK in response to uplink transmission.

Transmission of control signalling from these groups is mutually independent, e.g., ACK/NAK can be transmitted to a UE regardless of whether the same UE is receiving scheduling information or not.

Downlink scheduling information is used to inform the UE how to process the downlink data transmission.

Uplink scheduling grants are used to assign resources to UEs for uplink data transmission.

The hybrid ARQ (HARQ) feedback in response to uplink data transmission consists of a single ACK/NAK bit per HARQ process.

### 7.1.1.3 MIMO and transmit diversity

The baseline antenna configuration for MIMO and antenna diversity is two transmit antennas at the cell site and two receive antennas at the UE. The higher-order downlink MIMO and antenna diversity (four TX and two or four RX antennas) is also supported.

Spatial division multiplexing (SDM) of multiple modulation symbol streams to a single UE using the same time-frequency resource is supported. When a MIMO channel is solely assigned to a single UE, it is known as single user (SU)-MIMO. The spatial division multiplexing of the modulation symbol streams for different UEs using the same time-frequency resource is denoted as spatial division multiple access (SDMA) or multi-user (MU)-MIMO.

Modes of operation of multiple transmit antennas at the cell site (denoted as MIMO mode) are spatial multiplexing, beamforming, and single-stream transmit diversity mode(s). The MIMO mode is restricted by the UE capability, e.g. number of receive antennas, and is determined taking into account the slow channel variation. The MIMO mode is adapted slowly (e.g. only at the beginning of communication or every several 100 msec), in order to reduce the required control signalling (including feedback) required to support the MIMO mode adaptation.

For control channel, only single stream using the multiple transmit antennas is supported.

### 7.1.1.4 MBMS

MBMS transmissions are performed in the following two ways:

- Multi-cell transmissions
- Single-cell transmissions

At least in case of multi-cell transmissions, the MTCH is mapped onto the MCH.

Tight inter-cell synchronization, in the order of substantially less than the cyclic prefix, is assumed in order for the UE to be able to combine multi-cell MBMS transmissions.

The MBMS transmission consisting of only broadcast/MBMS related information share the same carrier with unicast traffic or can be transmitted on a separate carrier (e.g. for a mobile TV application).

## 7.1.2 Physical layer procedure

### 7.1.2.1 Scheduling

The Node B scheduler (for unicast transmission) dynamically controls which time/frequency resources are allocated to a certain user at a given time. Downlink control signaling informs UE(s) what resources and respective transmission formats have been allocated. The scheduler can instantaneously choose the best multiplexing strategy from the available methods; e.g. frequency localized or frequency distributed transmission. The flexibility in selecting resource blocks and multiplexing users (7.1.1.2) will influence the available scheduling performance. Scheduling is tightly integrated with link adaptation (7.1.2.2) and HARQ (7.1.2.3). The decision of which user transmissions to multiplex within a given sub-frame may for example be based on

- QoS parameters and measurements,
- payloads buffered in the Node-B ready for scheduling,
- pending retransmissions,

- CQI reports from the UEs,
- UE capabilities,
- UE sleep cycles and measurement gaps/periods,
- system parameters such as bandwidth and interference level/patterns,
- etc.

### 7.1.2.2 Link adaptation

Link adaptation (AMC: adaptive modulation and coding) with various modulation schemes and channel coding rates is applied to the shared data channel. The same coding and modulation is applied to all groups of resource blocks belonging to the same L2 PDU scheduled to one user within one TTI and within a single stream. This applies to both localized and distributed transmission.

The overall coding and modulation is illustrated in Figure 7.1.

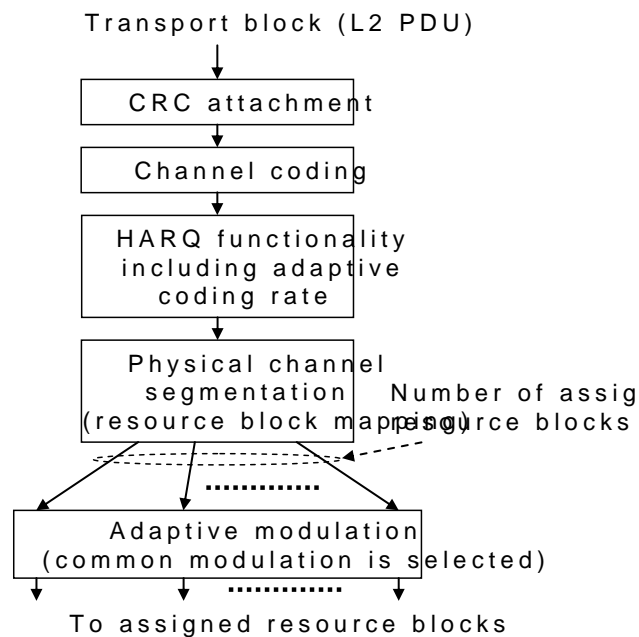

**Figure 7.1: Resource block-common adaptive modulation and resource block-common channel coding rate scheme (for localized and distributed transmission modes).**

### 7.1.2.3 HARQ

Downlink HARQ is based on Incremental Redundancy. Note that Chase Combining is a special case of Incremental Redundancy and is thus implicitly supported as well.

The N-channel Stop-and-Wait protocol is used for downlink HARQ.

### 7.1.2.4 Cell search

Cell search is the procedure by which a UE acquires time and frequency synchronization with a cell and detects the Cell ID of that cell. E-UTRA cell search supports a scalable overall transmission bandwidth from 1.25 to 20 MHz.

E-UTRA cell search is based on two signals ("channels") transmitted in the downlink, the "SCH" (Synchronization Channel) and "BCH" (Broadcast Channel).

The primary purpose of the SCH is to enable acquisition of the frequency and received timing, i.e., at least the SCH symbol timing, and frequency of the downlink signal. The UE can obtain the remaining cell/system-specific information from the BCH, SCH and also from some additional channels, such as the reference symbols. The primary purpose of the BCH is to broadcast a certain set of cell and/or system-specific information similar to the current UTRA BCH transport channel.



Aside from the SCH symbol timing and frequency information, the UE must acquire at least the following cell-specific information.

- The overall transmission bandwidth of the cell
- Cell ID
- Radio frame timing information when this is not directly given by the SCH timing, i.e., if the SCH is transmitted more than once every radio frame
- Information regarding the antenna configuration of the cell (number of transmitter antennas)
- Information regarding the BCH bandwidth if multiple transmission bandwidths of the BCH are defined
- CP length information regarding the sub-frame in which the SCH and/or BCH are transmitted

Each set of information is detected by using one or several of the SCH, reference symbols, or the BCH.

The SCH and BCH are transmitted one or multiple times every 10-msec radio frame.

SCH structure is based on the constant bandwidth of 1.25 MHz regardless of the overall transmission bandwidth of the cell, at least for initial cell search.

### 7.1.2.5 Inter-cell interference mitigation

There are three, not mutually exclusive approaches to inter-cell interference mitigation:

- Inter-cell-interference randomization
- Inter-cell-interference cancellation
- Inter-cell-interference co-ordination/avoidance

In addition, the use of beam-forming antenna solutions at the base station is a general method that can also be seen as a means for downlink inter-cell-interference mitigation. The main focus during the study item has been on different schemes for interference coordination. The common theme of inter-cell-interference co-ordination/avoidance is to apply restrictions to the downlink resource management (configuration for the common channels and scheduling for the non common channels) in a coordinated way between cells. These restrictions can be in the form of restrictions to what time/frequency resources are available to the resource manager or restrictions on the transmit power that can be applied to certain time/frequency resources. It has been concluded that this is mainly a scheduler implementation issue apart from additional inter-node communication and/or additional UE measurements and reporting.

## 7.1.3 Physical layer measurements

### 7.1.3.1 UE measurements

#### 7.1.3.1.1 Measurements for Scheduling

##### 7.1.3.1.1.1 Channel Quality Measurements

The UE is able to measure and report to the Node B the channel quality of one resource block or a group of resource blocks, in form of a Channel quality indicator (CQI). In order to allow for efficient trade-off between UL signaling overhead and link-adaptation/scheduling performance taking varying channel-conditions and type of scheduling into account, the time granularity of the CQI reporting is adjustable in terms of sub-frame units (periodic or triggered) and set on a per UE or per UE-group basis.

CQI feedback from UE which indicates the downlink channel quality can be used at Node B at least for the following purposes:

- Time/frequency selective scheduling
- Selection of modulation and coding scheme
- Interference management
- Transmission power control for physical channels, e.g., physical/L2-control signaling channels.

#### 7.1.3.1.1.2 Measurements for Interference Coordination/Management

Channel quality measurements defined in clause 7.1.3.1.1.1 and some measurements defined in clause 7.1.3.1.2 can be used for interference coordination/management purpose.

#### 7.1.3.1.2 Measurements for Mobility

In order to support efficient mobility in E-UTRAN, the UEs are required to identify and measure the relevant measurement quantities of neighbour cells and the serving cell. Such measurements for mobility are needed in the following mobility functions:

- 1) PLMN selection
- 2) Cell selection and cell reselection
- 3) Handover decision

##### 7.1.3.1.2.1 Intra-frequency neighbour measurements

Neighbour cell measurements performed by the UE are named intra-frequency measurements when the UE can carry out the measurements without re-tuning its receiver.

##### 7.1.3.1.2.2 Inter-frequency neighbour measurements

Neighbour cell measurements are considered inter-frequency measurements when the UE needs to re-tune its receiver in order to carry out the measurements.

In case of inter-frequency measurements, the network needs to be able to provide UL/DL idle periods for the UE to perform necessary neighbour measurements.

##### 7.1.3.1.2.3 Inter RAT measurements

Neighbour measurements are considered inter-RAT measurements when UE needs to measure other radio access technology cells. For these kinds of measurements, the network needs to be able to provide UL/DL idle periods.

##### 7.1.3.1.2.4 Measurement gap control

In case the UE needs UL/DL idle periods for making neighbour measurements or inter-RAT measurements, the network needs to provide enough idle periods for the UE to perform the requested measurements. Such idle periods are created by the scheduler, i.e. compressed mode is assumed not needed.

## 7.2 Uplink transmission scheme

For both FDD and TDD, the basic uplink transmission scheme is based on low-PAPR single-carrier transmission (SC-FDMA) with cyclic prefix to achieve uplink inter-user orthogonality and to enable efficient frequency-domain equalization at the receiver side. Each 10 ms radio frame is divided into 20 equally sized sub-frames and scheduling can operate on a sub-frame level. In addition, for coexistence with LCR-TDD, a frame structure according to [2], clause 6.2.1.1.1, is also supported when operating E-UTRA in TDD mode. To allow for multi-user MIMO reception at the Node B, transmission of orthogonal pilot patterns from single Tx-antenna UEs is part of the baseline uplink transmission scheme.

### 7.2.1 Basic transmission scheme

The basic uplink transmission scheme is SC-FDMA with cyclic prefix to achieve uplink inter-user orthogonality and to enable efficient frequency-domain equalization at the receiver side, see Figure 7.2.

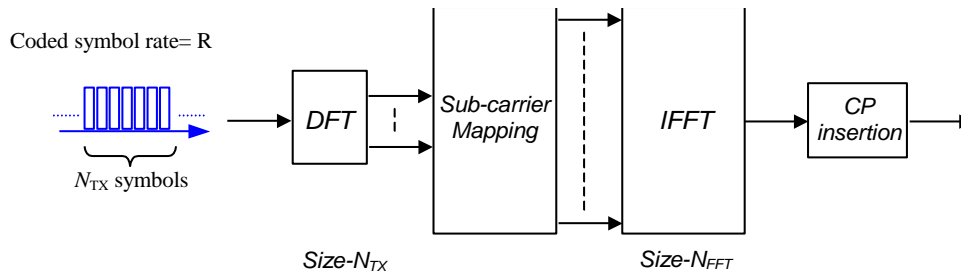

**Figure 7.2: Transmitter structure for SC-FDMA.**

The sub-carrier mapping determines which part of the spectrum that is used for transmission by inserting a suitable number of zeros at the upper and/or lower end in Figure 7.3. Between each DFT output sample  $L-1$  zeros are inserted. A mapping with  $L=1$  corresponds to localized transmissions, i.e., transmissions where the DFT outputs are mapped to consecutive sub-carriers. With  $L>1$ , distributed transmissions result, which are considered as a complement to localized transmissions for additional frequency diversity.

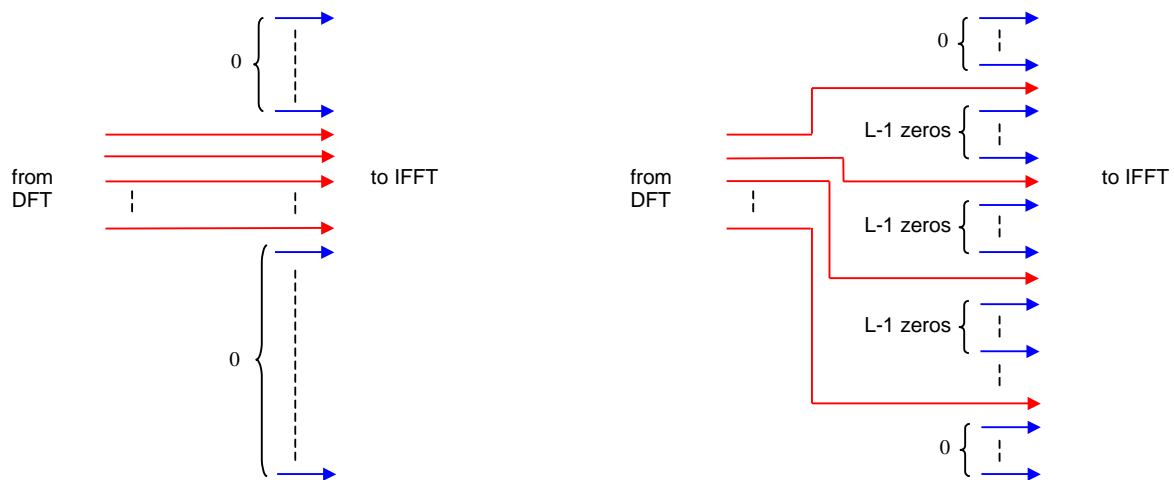

**Figure 7.3: Localized mapping (left) and distributed mapping (right).**

Information about the basic uplink parameters for operation in both paired and unpaired spectrum are given in [2] clause 9.1.1. For operation in unpaired spectrum with these parameters (generic frame structure), idle symbols are included at DL/UL switching points and the idle period, required in the Node B at UL/DL switching points, is created by timing advance means. Note that, for operation in unpaired spectrum there is an additional numerology, compatible with LCR-TDD, see [2]. The sub-frame structure defined in [2] contains two short blocks and  $N$  long blocks.

The minimum TTI for uplink transmission is equal to the uplink sub-frame duration.

### 7.2.1.1 Modulation scheme

Information about the uplink modulation scheme for operation are given in [2] clause 9.1.1.1.

### 7.2.1.2 Multiplexing including reference signal structure

#### 7.2.1.2.1 Uplink data multiplexing

The channel-coded, interleaved, and data-modulated information [Layer 3 information] is mapped onto SC-FDMA time/frequency symbols. The overall SC-FDMA time/frequency resource symbols can be organized into a number of resource units (RU). Each RU consists of a number ( $M$ ) of consecutive or non-consecutive sub-carriers during the  $N$  long blocks within one sub-frame. To support the localized and distributed transmission two types of RUs are defined as follows:

- Localized RU (LRU), which consists of  $M$  consecutive sub-carriers during  $N$  long blocks.
- Distributed RU (DRU), which consists of  $M$  equally spaced non-consecutive sub-carriers during  $N$  long blocks.

This results in the number of RUs depending on system bandwidth as shown in [2] clause 9.1.1.2.1.

#### 7.2.1.2.2 Uplink reference-signal structure

Uplink reference signals are transmitted within the two short blocks, which are time-multiplexed with long blocks. Uplink reference signals are received and used at the Node B for the following two purposes:

- Uplink channel estimation for uplink coherent demodulation/detection
- Uplink channel-quality estimation for uplink frequency- and/or time-domain channel-dependent scheduling

The uplink reference signals are based on CAZAC sequences.

Multiple mutually orthogonal reference signals can be created and be allocated to:

- A single multi-transmit-antenna UE to support e.g. uplink multi-layer transmission (MIMO)
- Different UEs within the same Node B

The uplink reference-signal structure allows for:

- Localized reference signals.
- Distributed reference signals.

#### 7.2.1.2.3 Multiplexing of L1/L2 control signaling

There are two types of L1 and L2 control-signaling information:

- data-associated signaling (e.g., transport format and HARQ information), which is associated with uplink data transmission, and
- data-non-associated signaling (e.g., CQI and/or ACK/NAK due to downlink transmissions, and scheduling requests for uplink transmission).

There are three multiplexing combinations for the uplink pilot, data, and L1/L2 control signaling within a sub-frame for a single UE:

- Multiplexing of pilot, data, and data-associated L1/L2 control signaling
- Multiplexing of pilot, data, data-associated, and data-non-associated L1/L2 control signaling
- Multiplexing of pilot and data-non-associated L1/L2 control signaling

#### 7.2.1.2.4 Uplink L1/L2 Control Signalling

Depending on presence or absence of uplink timing synchronization, the uplink L1/L2 control signaling can differ.

In the case of time synchronization being present, the outband control signaling consists of

- Data-associated control signaling
- CQI
- ACK/NAK
- Synchronous random access (scheduling request, resource request)

Data-associated control signalling can only be transmitted together with user data.

The CQI informs the scheduler about the current channel conditions as seen by the UE. If MIMO transmission is used, the CQI includes necessary MIMO-related feedback.

The HARQ feedback in response to downlink data transmission consists of a single ACK/NAK bit per HARQ process.

The synchronized random access is used by the UE to request resources for uplink data transmission.

In the case of time synchronization not being present, the outband control signalling consists of

- Non-synchronized random access

### 7.2.1.3 MIMO

The baseline antenna configuration for uplink single-user MIMO is two transmit antennas at the UE and two receive antennas at the Cell site. If the UE has only single power amplifier and two transmit antennas, the antenna switching/selection is the only option that is supported for SU-MIMO.

To allow for Multi-user MIMO reception at the Node B, allocation of the same time and frequency resource to two UEs, each of which transmitting on a single antenna, is supported as part of the uplink baseline configuration.

### 7.2.1.4 Power De-rating Reduction

Single-carrier transmission allows for further power de-rating reduction, e.g., through the use of specific modulation, clipping, spectral filtering, etc.

## 7.2.2 Physical channel procedure

### 7.2.2.1 Random access procedure

The random access procedure is classified into two categories:

- non-synchronized random access, and
- synchronized random access.

#### 7.2.2.1.1 Non-synchronized random access

The non-synchronized random access is used when i) the UE uplink has not been time synchronized or ii) the UE uplink loses synchronization. The non-synchronized access allows the Node B to estimate, and, if needed, adjust the UE transmission timing to within a fraction of the cyclic prefix.

The random-access procedure is based on transmission of a random-access burst. Time frequency resources for the random-access attempts are controlled by the RRM configuration.

The non-synchronized random access preamble is used for at least UE uplink time synchronization, signature detection.

Prior to attempting a non-synchronized random access, the UE shall synchronize to the downlink transmission.

##### 7.2.2.1.1.1 Power control for non-synchronized random access

The power control scheme designed assumes no intra-cell interference from data transmissions (i.e., TDM/FDM operation).

Open loop power control is used to determine the initial transmit power level. It is possible to vary the random access burst transmit power between successive bursts using:

- a) Power ramping with configurable step size including zero step size for both FDD and TDD case
- b) Per-burst open loop power determination for TDD case only

#### 7.2.2.1.2 Synchronized random access

The synchronized random access is used when the UE uplink is time synchronized by the Node B. The purpose is for the UE to request resources for uplink data transmission. One of the objectives of the synchronized random access procedure is to reduce the overall latency.

Synchronized random access and data transmission are also time and/or frequency multiplexed.

### 7.2.2.2 Scheduling

The uplink should allow for both scheduled (Node B controlled) access and contention-based access.

In case of scheduled access the UE is dynamically allocated a certain frequency resource for a certain time (i.e. a time/frequency resource) for uplink data transmission. Downlink control signaling informs UE(s) what resources and respective transmission formats have been allocated. The decision of which user transmissions to multiplex within a given sub-frame may for example be based on

- QoS parameters and measurements,
- payloads buffered in the UE ready for transmission,
- pending retransmissions
- uplink channel quality measurements
- UE capabilities,
- UE sleep cycles and measurement gaps/periods,
- system parameters such as bandwidth and interference level/patterns,
- etc.

### 7.2.2.3 Link adaptation

Uplink link adaptation is used in order to guarantee the required minimum transmission performance of each UE such as the user data rate, packet error rate, and latency, while maximizing the system throughput.

Three types of link adaptation are performed according to the channel conditions, the UE capability such as the maximum transmission power and maximum transmission bandwidth etc., and the required QoS such as the data rate, latency, and packet error rate etc. Three link adaptation methods are as follows.

- Adaptive transmission bandwidth
- Transmission power control
- Adaptive modulation and channel coding rate

### 7.2.2.4 Power control

For the uplink, transmission power control, being able to compensate for at least path loss and shadowing is applied.

### 7.2.2.5 HARQ

Uplink HARQ is based on Incremental Redundancy. Note that Chase Combining is a special case of Incremental Redundancy and is thus implicitly supported as well.

The N-channel Stop-and-Wait protocol is used for uplink HARQ.

### 7.2.2.6 Uplink timing control

In order to keep time alignment between uplink transmissions from multiple UEs at the receiver side, timing-control commands, commanding UEs to advance or retract the respective transmit timing, can be transmitted on the downlink.

### 7.2.2.7 Inter-cell interference mitigation

The basic approaches to inter-cell interference mitigation for uplink are as follows.

- Co-ordination/avoidance i.e. by fractional re-use of time/frequency resources
- Inter-cell-interference randomization
- Inter-cell-interference cancellation
- Power control

In addition, the use of beam-forming antenna solutions at the base station is a general method that can also be seen as a means for uplink inter-cell-interference mitigation.

The main focus during the study item has been on different schemes for interference coordination. The common theme of inter-cell-interference co-ordination/avoidance is to apply restrictions to the uplink resource management in a

coordinated way between cells. These restrictions can be in the form of restrictions to what time/frequency resources are available to the resource manager or restrictions on the transmit power that can be applied to certain time/frequency resources. It has been concluded that this is mainly a scheduler implementation issue apart from additional inter-node communication and/or additional UE measurements and reporting.

## 8 Layer 2 and RRC evolution for evolved UTRA

Layer 2 is split into the following sublayers: Medium Access Control (MAC), Radio Link Control (RLC) and Packet Data Convergence Protocol (PDCP). Figure 8.1 and Figure 8.2 below depict the PDCP/RLC/MAC architecture for downlink and uplink respectively, where:

- Service Access Points (SAP) for peer-to-peer communication are marked with circles at the interface between sublayers. The SAP between the physical layer and the MAC sublayer provides the transport channels. The SAPs between the MAC sublayer and the RLC sublayer provide the logical channels. The SAPs between the RLC sublayer and the PDCP sublayer provide the radio bearers.
- The multiplexing of several logical channels on the same transport channel is possible;
- In the uplink, only one transport block is generated per TTI in the non-MIMO case;

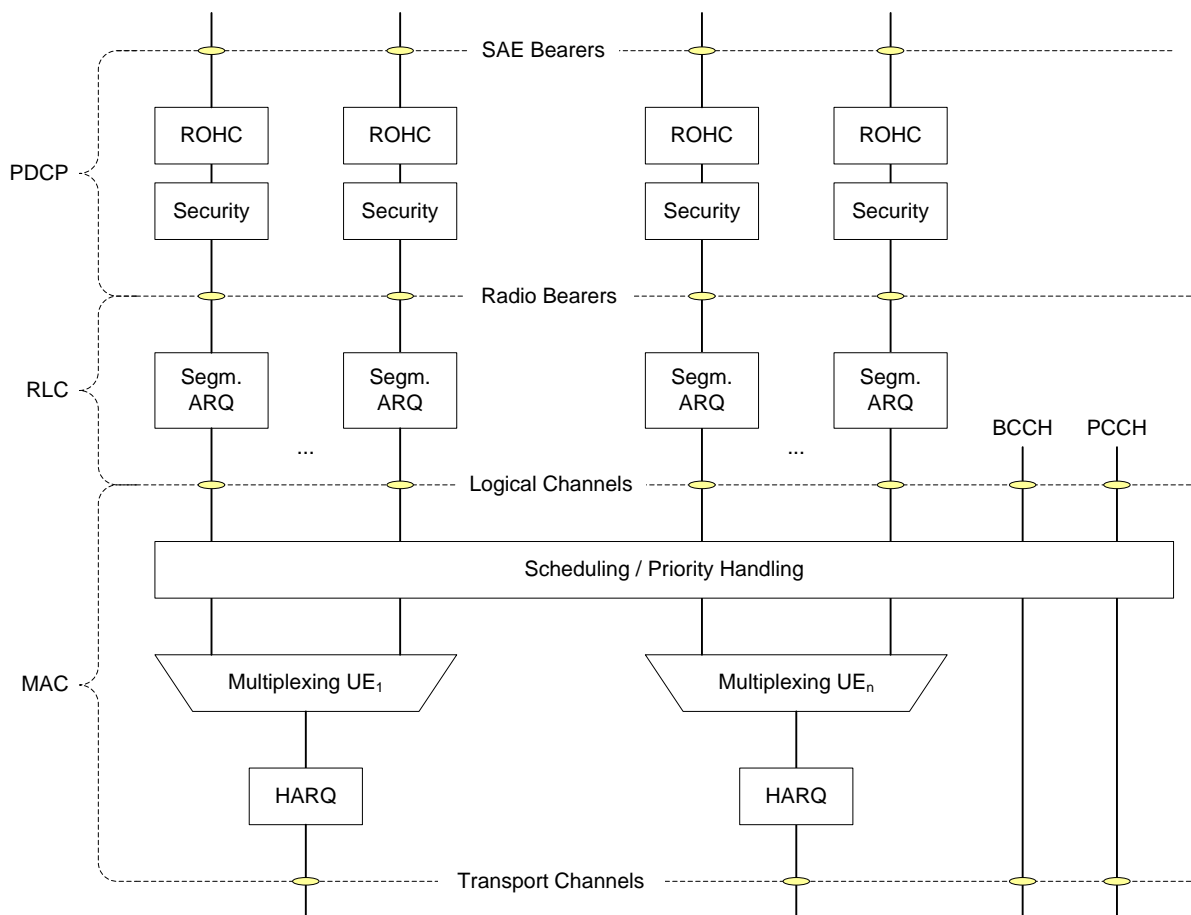

Figure 8.1: Layer 2 Structure for DL in eNB and aGW

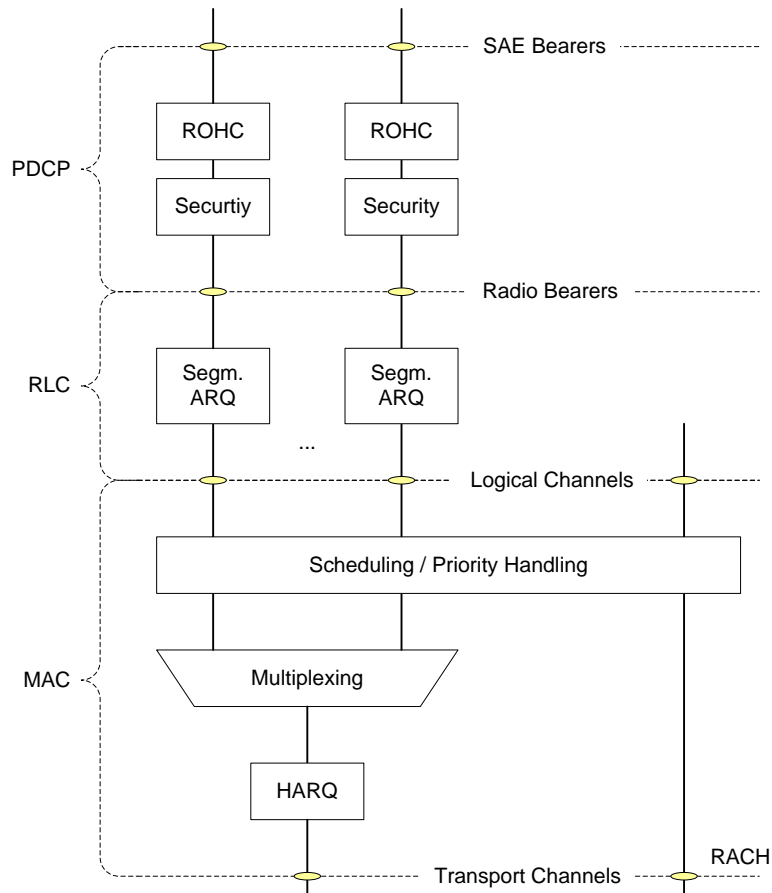

Figure 8.2: Layer 2 Structure for UL in UE

## 8.1 MAC sublayer

This subclause provides an overview on services and functions provided by the MAC sublayer.

### 8.1.1 Services and functions

The main services and functions of the MAC sublayer include at least:

- Mapping between logical channels and transport channels;
- Multiplexing/demultiplexing of RLC PDUs belonging to one or different radio bearers into/from transport blocks (TB) delivered to/from the physical layer on transport channels;
- Traffic volume measurement reporting;
- Error correction through HARQ;
- Priority handling between logical channels of one UE;
- Priority handling between UEs by means of dynamic scheduling;
- Transport format selection;

### 8.1.2 Logical channels

The MAC sublayer provides data transfer services on logical channels. A set of logical channel types is defined for different kinds of data transfer services as offered by MAC. Each logical channel type is defined by what type of information is transferred.



A general classification of logical channels is into two groups:

- Control Channels (for the transfer of C-plane information);
- Traffic Channels (for the transfer of U-plane information).

There is one MAC entity per cell. MAC generally consists of several function blocks (transmission scheduling functions, per UE functions, MBMS functions, MAC control functions, transport block generation...).

### 8.1.2.1 Control channels

Control channels are used for transfer of C-plane information only. The control channels offered by MAC are listed below. Note that the need for additional channels may be identified in the WI phase.

- **Broadcast Control Channel (BCCH)**

A downlink channel for broadcasting system control information.

- **Paging Control Channel (PCCH)**

A downlink channel that transfers paging information. This channel is used when the network does not know the location cell of the UE.

- **Multicast Control Channel (MCCH)**

A point-to-multipoint downlink channel used for transmitting MBMS control information from the network to the UE, for one or several MTCHs. This channel is only used by UEs that receive MBMS.

- **Dedicated Control Channel (DCCH)**

A point-to-point bi-directional channel that transmits dedicated control information between a UE and the network. Used by UEs having an RRC connection.

### 8.1.2.2 Traffic channels

Traffic channels are used for the transfer of U-plane information only. The traffic channels offered by MAC are:

- **Dedicated Traffic Channel (DTCH)**

A Dedicated Traffic Channel (DTCH) is a point-to-point channel, dedicated to one UE, for the transfer of user information. A DTCH can exist in both uplink and downlink.

- **Multicast Traffic Channel (MTCH)**

A point-to-multipoint downlink channel for transmitting traffic data from the network to the UE. This channel is only used by UEs that receive MBMS.

### 8.1.3 Mapping between logical channels and transport channels

Figure 8.3 depicts the mapping between logical and transport channels. Note that the need for other mappings may be identified in the WI phase.

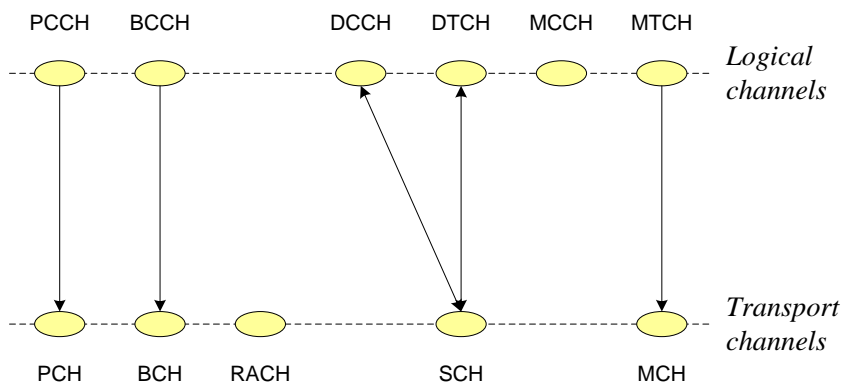

**Figure 8.3: Mapping between logical channels and transport channels**

### 8.1.3.1 Mapping in Uplink

In the uplink, at least the following connections between logical channels and transport channels exist:

- DCCH can be mapped to UL-SCH;
- DTCH can be mapped to UL-SCH.

### 8.1.3.2 Mapping in downlink

In the downlink, at least the following connections between logical channels and transport channels exist:

- BCCH can be mapped to BCH;
- PCCH can be mapped to PCH;
- DCCH can be mapped to DL-SCH;
- DTCH can be mapped to DL-SCH;
- MTCH can be mapped to MCH;

## 8.2 RLC sublayer

The main services and functions of the RLC sublayer include at least:

- Transfer of upper layer PDUs supporting at least AM;
- Error Correction through ARQ;
- Segmentation according to the size of the TB;
- Resegmentation (e.g. when the radio quality, i.e. the supported TB size changes);
- In-sequence delivery of upper layer PDUs;
- Duplicate Detection;
- Protocol error detection and recovery;
- Reset.

Note that the reliability of RLC is configurable: for some bearers may tolerate rare losses (e.g. TCP traffic).

## 8.3 PDCP sublayer

Figure 8.4 illustrates a model of the PDCP sublayer.

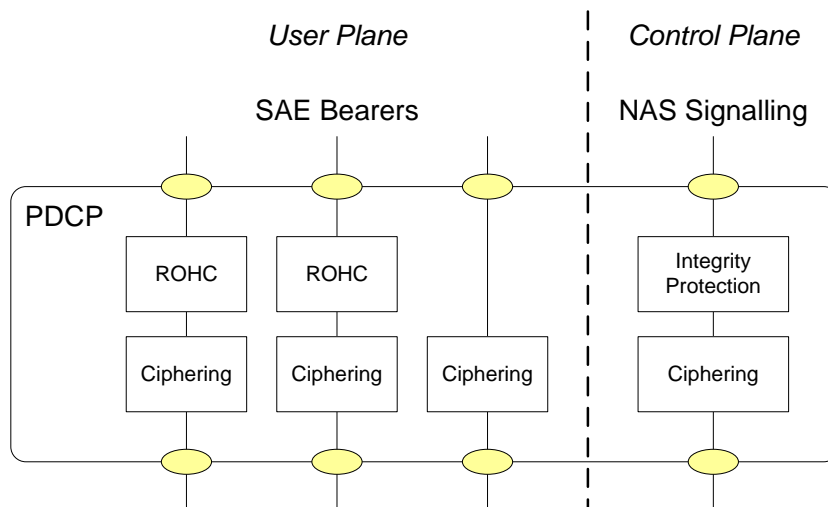

**Figure 8.4: Model of PDCP sublayer**

The main services and functions of the PDCP sublayer include at least:

- Header compression and decompression: ROHC only;
- Transfer of user data: transmission of user data means that PDCP receives PDCP SDU from the NAS and forwards it to the RLC layer and vice versa;
- Ciphering of U- plane data and C-plane data (NAS Signalling);
- Integrity protection of C-plane data (NAS signalling);

NOTE 1: The U-plane and C-plane PDCP entities are located in the UPE and MME, respectively.

NOTE 2: When compared to UTRAN, the *lossless DL RLC PDU size change* is not required.

## 8.4 RRC

This subclause provides an overview on services and functions provided by the RRC sublayer.

### 8.4.1 Services and functions

The main services and functions of the RRC sublayer include at least:

- Broadcast of System Information related to the non-access stratum (NAS);
- Broadcast of System Information related to the access stratum (AS);
- Paging;
- Establishment, maintenance and release of an RRC connection between the UE and E-UTRAN including:
  - Allocation of temporary identifiers between UE and E-UTRAN;
  - Configuration of radio resources for RRC connection.
- Security functions including:
  - Integrity protection for RRC messages;

- Establishment, maintenance and release of point to point Radio Bearers including configuration of radio resources for the Radio Bearers;
- Mobility functions including:
  - UE measurement reporting and control of the reporting for inter-cell and inter-RAT mobility;
  - Inter-cell handover;
  - UE cell selection and reselection and control of cell selection and reselection;
  - Context transfer between eNBs.
- UE measurement reporting and control of the reporting;
- NAS direct message transfer to/from NAS from/to UE.

## 8.4.2 RRC protocol states & state transitions

RRC uses the following states:

- **RRC\_IDLE:**
  - UE specific DRX configured by NAS;
  - Broadcast of system information;
  - Paging;
  - Cell re-selection mobility;
  - The UE shall have been allocated an id which uniquely identifies the UE in a tracking area;
  - No RRC context stored in the eNB.
- **RRC\_CONNECTED:**
  - UE has an E-UTRAN-RRC connection;
  - UE has context in E-UTRAN;
  - E-UTRAN knows the cell which the UE belongs to;
  - Network can transmit and/or receive data to/from UE;
  - Network controlled mobility (handover);
  - Neighbour cell measurements;
  - At RLC/MAC level:
    - UE can transmit and/or receive data to/from network;
    - UE monitors control signalling channel for shared data channel to see if any transmission over the shared data channel has been allocated to the UE;
    - UE also reports channel quality information and feedback information to eNB;
    - DRX/DTX period can be configured according to UE activity level for UE power saving and efficient resource utilization. This is under control of the eNB.

## 9 Architecture for evolved UTRAN

### 9.1 Evolved UTRAN architecture

This chapter describes the definition of an evolved UTRAN Architecture in terms of logical nodes, each node hosting a set of functions and the related physical interfaces.

The evolved UTRAN consists of eNBs, providing the evolved UTRA U-plane and C-plane protocol terminations towards the UE. The eNBs are interconnected with each other by means of the X2 interface. It is assumed that there always exist an X2 interface between the eNBs that need to communicate with each other, e.g. for support of handover of UEs in LTE\_ACTIVE.

The eNBs are also connected by means of the S1 interface to the EPC (Evolved Packet Core). The S1 interface support a many-to-many relation between aGWs and eNBs.

The EUTRAN architecture is illustrated in Figure 9.1.

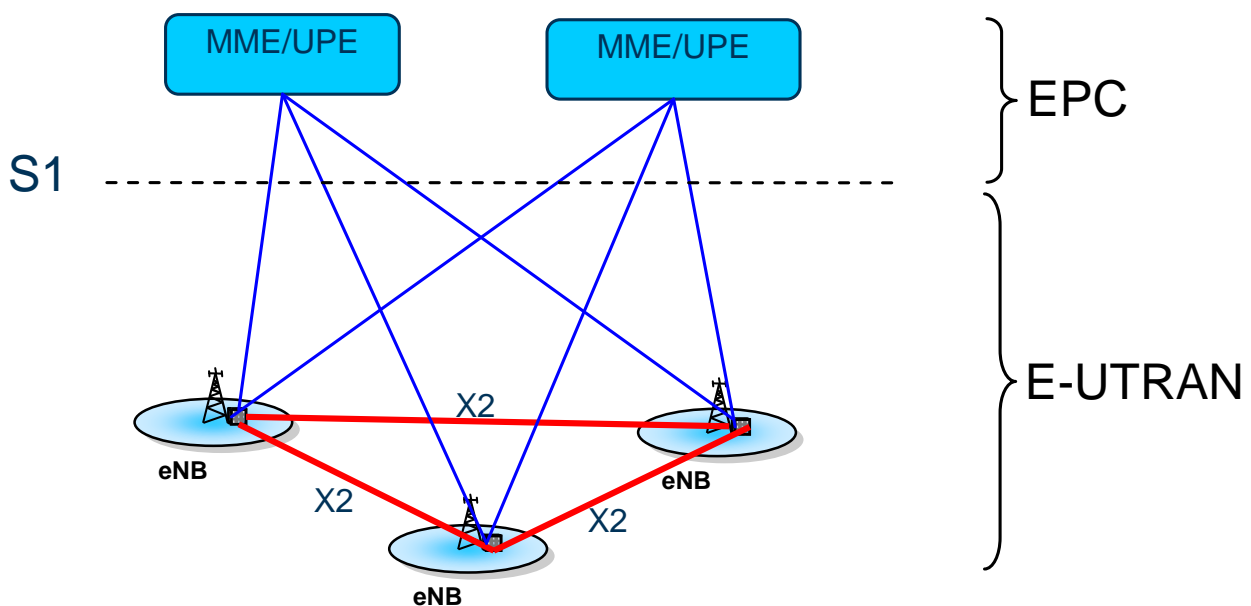

Figure 9.1: E-UTRAN architecture

### 9.2 Functional split

The eNB host the following functions:

- Functions for Radio Resource Management: Radio Bearer Control, Radio Admission Control, Connection Mobility Control, Dynamic Resource Allocation (scheduling).

The MME hosts the following functions:

- Distribution of paging messages to the eNBs.

The UPE hosts the following functions:

- IP Header Compression and encryption of user data streams ;
- Termination of U-plane packets for paging reasons ;
- Switching of U-plane for support of UE mobility.

## 9.3 Interfaces

### 9.3.1 S1 interface

#### 9.3.1.1 Definition

The S1 interface is the interface that separate E-UTRAN and EPC. The S1 interface consists of two parts:

C-plane: S1-C is the interface between eNB and MME function in EPC.

U-plane: S1-U is the interface between eNB and UPE function in EPC.

The S1 interface shall be specified so that there is a many-to-many relation between aGWs and eNBs.

#### 9.3.1.2 S1-C RNL protocol functions

The S1-C interface supports at least the following functions:

- Mobility functions: Support for intra- and inter-system mobility of UE(s).
- Connection Management Functions: Functions for handling LTE\_IDLE to LTE\_ACTIVE transitions, roaming area restrictions etc.
- SAE Bearer Management: Setup, modification and release of SAE Bearers.
- General S1 management and error handling functions: Request to release, and release of all bearers, S1 reset functions, as well as some kind of path supervision.
- Paging of a UE in the eNB.
- Transport of NAS information between EPC and UE.
- MBMS support functions.

#### 9.3.1.3 S1-U RNL protocol functions

The S1-U interface supports the tunnelling of end user packets between the eNB and the UPE. The tunnelling protocols support the following functions:

- Indication of the SAE Access Bearer in the target node that the packet belongs to.
- Means to minimize packet losses due to mobility.
- Error handling mechanism
- MBMS support functions
- Packet loss detection mechanism

#### 9.3.1.4 S1-X2 similarities

S1-U and X2-U use the same U-plane protocol in order to minimize protocol processing for the eNB at the time of data forwarding.

### 9.3.2 X2 interface

#### 9.3.2.1 Definition

The X2 interface is the interface between eNBs. The X2 interface consists of two parts:

C-plane: X2-C is the C-plane interface between eNBs.

U-plane: X2-U is the U-plane interface between eNBs

### 9.3.2.2 X2-C RNL Protocol Functions

The X2-C interface supports the following functions:

- Mobility functions: Support for UE mobility between eNBs, including e.g. handover signalling and control of U-plane tunnels.
- Multi-cell RRM functions: Support for multi-cell RRM, e.g. measurement reporting.
- General X2 management and error handling functions.

### 9.3.2.3 X2-U RNL Protocol Functions

The X2-U interface supports the tunneling of end user packets between the eNBs. The tunneling protocols support the following functions:

- Indication of the SAE Access Bearer in the target node that the packet belongs to.
- Means to minimize packet losses due to mobility.

## 9.4 Intra-LTE-access-system mobility

### 9.4.1 Intra-LTE-access-system mobility support for UE in LTE\_IDLE

Refer to clause 7.7 in [3].

### 9.4.2 Intra LTE-Access-System Mobility Support for UE in LTE\_ACTIVE

#### 9.4.2.1 Description of Intra-LTE-Access Mobility Support for UEs in LTE\_ACTIVE

The Intra-LTE-Access Mobility Support for UEs in LTE\_ACTIVE handles all necessary steps already known from state of the art relocation/handover procedures, like processes that precedes the final HO decision on the source network side (control and evaluation of UE and eNB measurements taking into account certain UE specific area restrictions), preparation of resources on the target network side, commanding the UE to the new radio resources and finally releasing resources on the (old) source network side. It contains mechanisms to transfer context data between evolved nodes, and to update node relations on C-plane and U-plane.

#### 9.4.2.2 Solution for Intra-LTE-Access Mobility Support for UEs in LTE\_ACTIVE

##### 9.4.2.2.1 C-plane handling:

The HO procedure is performed without MME/UPE involvement, i.e. preparation messages are directly exchanged between the eNBs. The release of the resources at the source side during the HO completion phase is triggered by the eNB.

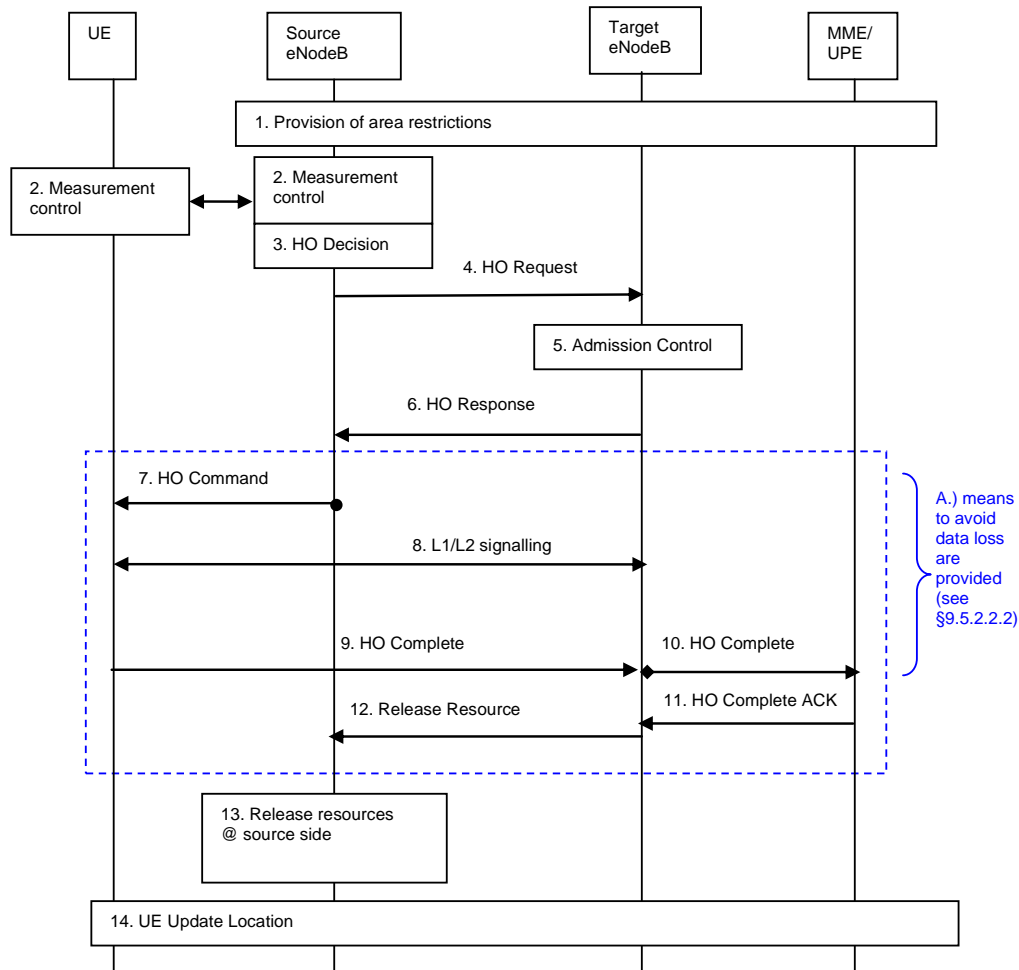

**Figure 9.2: Information flow for Intra-LTE-Access Mobility Support**

- 1) The UE context within the source eNB contains information regarding roaming restrictions which were provided either at connection establishment or at the last TA update.
  - 2) The source eNB entity configures the UE measurement procedures according to the area restriction information. Measurements provided by the source eNB entity may assist the function controlling the UE's connection mobility.
  - 3) Based on measurement results from the UE and the source eNB, probably assisted by additional RRM specific information, the source eNB decides to handover the UE to a cell controlled by the target eNB.
  - 4) The source eNB issues a HO Request to the target eNB entity passing necessary information to prepare the HO at the target side. The target eNB configures the required resources.
  - 5) Admission Control is performed by the target eNB to increase the likelihood of a successful HO, if the resources can be granted by target eNB.
  - 6) The HO preparation is finished at the target side, information for the UE to reconfigure the radio path towards the target side is passed to the source eNB.
- A) from step 7) until 12) means to avoid data loss during HO are provided and are detailed in § 9.4.2.2.2.
- 7) The UE is commanded by the source eNB entity to perform the HO, target side radio resource information is contained.
  - 8) The UE gains synchronisation at the target side.



- 9) Once the UE has successfully accessed the cell, it sends an indication to the target eNB that the handover is completed.
- 10) The MME/UPE is informed that the UE has changed cell. The UPE switches the data path to the target side and can release any U-plane/TNL resources towards the source eNB.
- 11) The MME/UPE confirms the HO Complete message with the HO Complete ACK message.
- 12) The target eNB triggers the release of resources at the source side. The target eNB can send this message directly after reception of message 9.
- 13) Upon reception of the Release Resource message, the source eNB can release radio and C-plane related resources in relation to the UE context. The source eNB should continue to perform data forwarding until an implementation dependent mechanism decides that data forwarding can be stopped and U-plane/TNL resources can be released.
- 14) If the new cell is member of a new Tracking Area, the UE needs to register with the MME/UPE which in turn updates the area restriction information on the target side.

#### 9.4.2.2.2 U-plane handling

The U-plane handling during the Intra-LTE-Access mobility activity for UEs in LTE\_ACTIVE takes the following principles into account to avoid data loss during HO and hence to support seamless/lossless service provision:

- During HO preparation a U-plane tunnel is established between the source eNB and the target eNB.
- During HO execution, user data may be forwarded from the source eNB to the target eNB. The forwarding may take place in a service dependent and implementation specific way.
  - Forwarding of user data from the source to the target eNB should take place as long as packets are received at the source eNB from the UPE.
- During HO completion:
  - After the MME/UPE was informed by the target eNB that the UE has gained access at the target eNB by the HO Complete message, the U-plane path is switched by the MME/UPE from the source eNB to the target eNB.
  - The source eNB shall continue forwarding of U-plane data as long as packets are received at the source eNB from the UPE.

## 9.5 Inter 3GPP access system mobility

### 9.5.1 Inter 3GPP access system mobility in Idle state

Refer to clause 7.5 in [3].

### 9.5.2 Inter 3GPP access system mobility handover

Refer to clause 7.8.2 in [3].

## 9.6 Resource establishment and QoS signalling

### 9.6.1 QoS concept and bearer service architecture

Refer to clause 7.12.2 and 7.12.3 in [3].

### 9.6.2 Resource establishment and QoS signalling

Resource establishment and QoS signaling in LTE/SAE has been accelerated by removing the signaling hierarchy in SAE bearer establishment in S1 control plane. Signalling of Access Stratum and Non Access Stratum information is done in parallel by piggybacking the NAS information in the AS signalling in S1 interface.

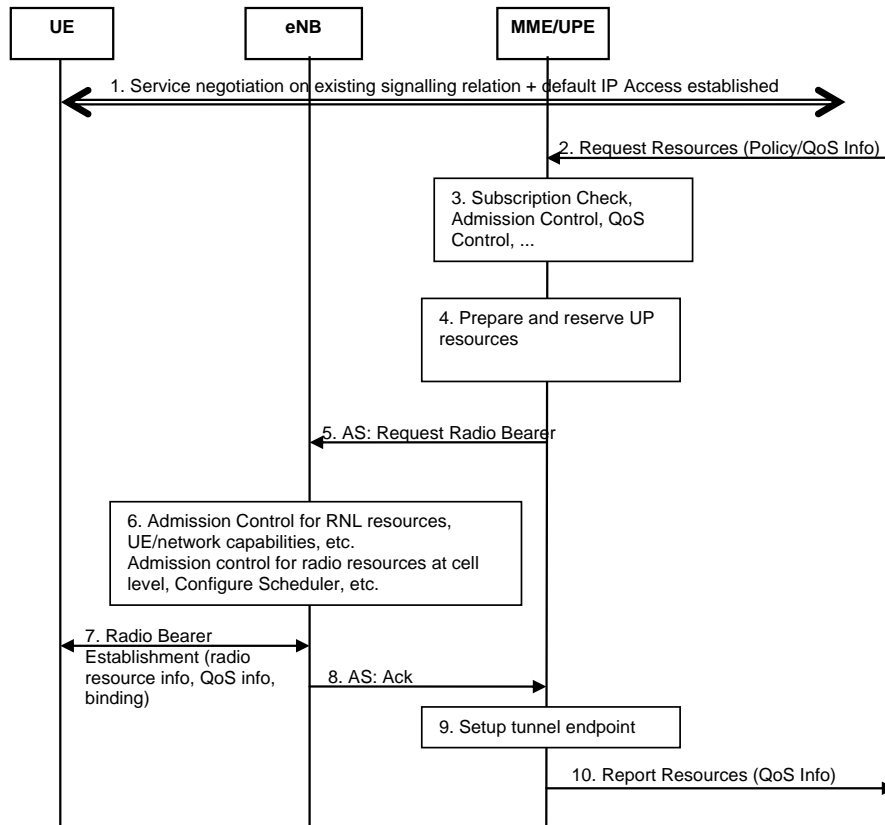

**Figure 9.3: Information flow for Resource Establishment in the Radio Network for application level signalling**

- 1) The UE has a signalling relation established with the network which relies on the default IP Access service.
- 2) The MME/UPE is triggered by a resource request which contains Policy/QoS Information corresponding to the requested service.
- 3) The MME/UPE checks the UE's subscription, performs admission control.
- 4) The MME/UPE reserves a U-plane configuration (including a tunnel endpoint) in the UPE
- 5) MME/UPE sends a request to the eNB to establish a Radio Bearer (RB)
- 6) The eNB performs admission control for RNL radio resources, and maps the received QoS information for the "PHY/MAC control" entity and triggers the allocation of radio resources

The "PHY/MAC control" receives the QoS information from the "RRC."

The "PHY/MAC control" uses this information to perform admission control for radio and processing resources at cell level and to generate the relevant HARQ entities and also to perform any mapping of logical channel to resource identifier configures the scheduler according to the received QoS information and allocates resources according to the received QoS information.

The "PHY/MAC control" returns the relevant configuration information (e.g. HARQ configuration, air interface identifiers, channel mapping etc) to the "RRC" entity.

- 7) The RB is established and UE is provided with information about the radio configuration necessary for the service.
- 8) The MME/UPE is informed about the successful outcome of the radio bearer establishment.
- 9) UPE function in the EPC is informed about tunnel endpoint.
- 10) The MME/UPE reports the outcome of the resource establishment.

## 9.7 Paging and C-plane establishment

Refer to clause 7.14 in [3].

For C-plane establishment, several control plane procedures will be executed in parallel. Encrypted NAS messages will be carried as Direct Transfer messages in both S1 and RRC messages.

## 9.8 Evaluations on for E-UTRAN architecture and migration

Following requirements on E-UTRAN architecture and migration have been identified in clause 9 of TR 25.913. For each requirement it is shortly discussed how it is fulfilled by the LTE architecture.

- a) A single E-UTRAN architecture should be agreed.

The agreed architecture for LTE is captured in clause 9.1.

- b) The E-UTRAN architecture shall be packet based, although provision should be made to support systems supporting real-time and conversational class traffic.

The E-UTRAN architecture in clause 9.1 is packet based and supports all kinds of services including real-time and conversational type of services.

- c) E-UTRAN architecture shall minimize the presence of "single points of failure" where possible without additional cost for backhaul.

Effects of "single points of failures" are limited to eNB sites, which are defined without architectural redundancy.

- d) E-UTRAN architecture shall simplify and minimize the introduced number of interfaces where possible

The E-UTRAN architecture consist of eNBs with corresponding interfaces. The E-UTRAN architecture contains two interfaces: S1 which is the interface between EPC and eNB, and X2 which is the interface between eNBs.

- e) Radio Network Layer (RNL) and Transport Network Layer (TNL) interaction should not be precluded if in the interest of improved system performance.

Interaction between RNL and TNL has not been precluded in the proposed architecture.

- f) E-UTRAN architecture shall support an end-to-end QoS. The TNL shall provide the appropriate QoS requested by the RNL.

The architecture supports end-to-end QoS and enhancements/simplifications of the QoS concept of Rel. 6.

- g) QoS mechanism(s) shall take into account the various types of traffic that exists to provide efficient bandwidth utilization: "C-plane" traffic, "U-plane" traffic, O&M traffic etc.

The discussed QoS mechanisms allow for differentiation of different types of traffic, e.g. signalling and different kinds of user data, and supports prioritization between different kinds of traffic.

- h) The E-UTRAN shall be designed in such a way to minimize the delay variation (jitter) for e.g. TCP/IP for packet communication.

The radio interface protocols of the U-plane are terminated in the eNB and UPE, which allows for small delay variations. E-UTRAN architecture allows for the minimisation of data loss during UE mobility between eNBs, which is expected to minimize the impact on TCP performance.

## 9.9 Support of roaming restrictions in LTE\_ACTIVE

Handling of roaming/area restrictions and handling of subscription specific preferences in LTE\_ACTIVE is performed in the eNB based on information provided by the aGW over the S1 interface.

## 10 RF related aspects of evolved UTRA

### 10.1 Scalable bandwidth

E-UTRA shall according to [4] allow scalable bandwidth operation of 1.25 MHz, 1.6MHz, 2.5 MHz, 5 MHz, 10 MHz, 15 MHz and 20 MHz. There are several implications of the flexible bandwidth, including performance and implementation aspects. When unwanted emissions requirements for a scalable bandwidth system are specified, there are also regulatory aspects related to both the way the unwanted emission requirements are specified and to identifying the relevant emission limits.

For the out-of-band emissions (close to the carrier) the present UTRA limits are specified both as ACLR (Adjacent Channel Leakage Ratio) and a Spectrum Mask. Several proposals in several RAN4 documents\* discuss how to specify ACLR and spectrum mask in a way similar to UTRA. It is also shown how emissions vary with the scalable bandwidth, which should be reflected in the out-of-band limits, at least for the UE. Proposals in \*documents 4several RAN introduce a new concept where adjacent channel leakage is specified in a measurement bandwidth related to the resource block size. It is pointed out in a RAN4 document\* that Out-of-band emissions for E-UTRA does not necessarily have to be specified as a spectrum mask, or that it has to be identical to the UTRA mask. What is important is that assurance is provided for co-existence, through ACLR, spectrum mask or other limits on Out-of-band emissions.

Out-of-band limits are set by 3GPP, but are referenced, included and applied by external regulatory bodies in recommendations, reports and co-existence studies\*. In defining the limits for LTE, those references should be considered to assure that E-UTRA provides sufficient compatibility with other services.

The present UTRA spurious emission limits are based on ITU-R SM.329 [7], which should also be the basis for LTE as discussed in \*documents 4several RAN. There are also additional UE and BS spurious emission limits defined as regional requirements for co-existence between different systems, including UTRA, GSM and PHS in the same or different bands. Some of these requirements should remain as pointed out in several of RAN4 documents\*, but there may also be new co-existence scenarios to consider. It is important for 3GPP to respect regional requirements and to take into account how the limits are applied and referenced in international and regional bodies.

It was shown in \*document 4a RAN that some aspects of the ITU-R SM.329 limits [7] may lead to unnecessarily tight requirements for the eNB. The regulatory aspects of this issue are at the moment being addressed further within CEPT/ECC.

Spurious emission limits are mainly driven by international recommendations, but some implementation considerations are also important. One such issue is how to define the limit between out-of-band and spurious emissions. ITU-R SM.329 [7] recommends this limit to be proportional to the (necessary) emission bandwidth. Several RAN4 documents\* considered the concept of starting the domain of the spurious emission requirements at a fixed offset of 10 MHz from the edge of the LTE carrier for any bandwidth. From an implementation perspective a RAN4 document\* indicated this to be feasible for the eNB. However, it was shown in several RAN4 documents\* that this approach appears to be not viable for the UE. Also here, considerations must be taken of implementation and regulatory aspects as well as co-existence with adjacent systems.

In some of the potential frequency bands, depending on the spectrum allocation conditions, sufficient frequency spectrum for the wider operation bandwidths may not be available. In that case, resource aggregation has been considered as one option. The implementation and complexity aspects of this issue are studied and summarized further in clause 12.2 in this TR.

As a summary of these studies it can be concluded that the scalable bandwidth needs to be properly considered when defining LTE unwanted emission requirements, taking into account co-existence with other systems, implementation and regulatory aspects. Based on the studies to date, scalable bandwidth is considered feasible.

Note: \*See clause 5.2 in [8]

### 10.2 Spectrum deployment

The conclusions in this chapter are preliminary and may need to be updated once the work in RAN4 progresses. Specially the comprehensive analysis of coexistence of E-UTRA operating in the same frequency band with other radio systems spans a large number of scenarios and requires a considerable amount of simulation work which is still ongoing. However, based on initial coexistence simulation results and additional analytical analysis RAN4 can draw a draft conclusion for the purpose of the Study Item.

Regarding coexistence of E-UTRA with E-UTRA and other radio technologies operating in different frequency bands similar requirements as currently specified for UTRA are anticipated. This concerns additional transmitter and receiver spurious emission requirements for coexistence which will be for LTE eNB and UE the same as today for UTRA and receiver blocking requirements for coexistence which need to be specified by RAN4 during the Work Item phase.

Regarding coexistence of E-UTRA with E-UTRA and E-UTRA with UTRA operating in the same frequency band on adjacent channels, initial coexistence simulation results for downlink have shown that this is feasible with requirements for E-UTRA similar to those for the current UTRA system. The analysis of the transmitter emissions of the E-UTRA UE indicated that behaviour is expected to be similar to the downlink however uplink coexistence simulation results are not available yet. Coexistence with GSM also needs to be analysed. Further coexistence studies for uplink and downlink are ongoing.

Based on the studies described above, focussed on scenarios considered most critical, coexistence of E-UTRA with E-UTRA and other radio technologies is seen feasible.

---

## 11 Radio resource management aspects of evolved UTRA

### 11.1 Introduction

The purpose of radio resource management (RRM) is to ensure the efficient use of the available radio resources and to provide mechanisms that enable E-UTRAN to meet radio resource related requirements identified in Chapter 10 of [4]. In particular, RRM in E-UTRAN provides means to manage (e.g. assign, re-assign and release) radio resources taking into account single and multi-cell aspects.

### 11.2 Definition and description of RRM functions

#### 11.2.1 Radio Bearer Control (RBC)

The establishment, maintenance and release of Radio Bearers (as defined in [25.813]) involves the configuration of radio resources associated with them. When setting up a radio bearer for a service, radio bearer control takes into account the overall resource situation in E-UTRAN, the QoS requirements of in-progress sessions and the QoS requirement for the new service. RB control is also concerned with the maintenance of radio bearers of in-progress sessions at the change of the radio resource situation due to mobility or other reasons. RB control is involved in the release of radio resources associated with RB:s at session termination, handover or at other occasions.

RBC is located in the eNodeB.

#### 11.2.2 Radio Admission Control (RAC)

The task of radio admission control is to admit or reject the establishment requests for new radio bearers. In order to do this, RAC takes into account the overall resource situation in E-UTRAN, the QoS requirements, the priority levels and the provided QoS of in-progress sessions and the QoS requirement of the new RB request. The goal of RAC is to ensure high radio resource utilization (by accepting RB requests as long as radio resources available) and at the same time to ensure proper QoS for in-progress sessions (by rejecting RB requests when they cannot be accommodated).

RAC is located in the eNodeB.

#### 11.2.3 Connection Mobility Control (CMC)

Connection mobility control is concerned with the management of radio resources in connection with idle or active mode mobility. In idle mode, the cell reselection algorithms are controlled by setting of parameters (thresholds and hysteresis values) that define the best cell and/or determine when the UE should select a new cell. Also, E-UTRAN broadcasts parameters that configure the UE measurement and reporting procedures. In active mode, the mobility of radio connections has to be supported. Handover decisions may be based on UE and eNodeB measurements. In

addition, handover decisions may take other inputs, such as neighbor cell load, traffic distribution, transport and hardware resources and Operator defined policies into account.

CMC is located in the eNodeB.

## 11.2.4 Packet Scheduling (PSC)

The task of packet scheduling is to allocate and de-allocate resources (including buffer and processing resources and resource blocks (*i.e. chunks*)) to user and control plane packets. PSC involves several sub-tasks, including the selection of RB:s whose packets are to be scheduled and managing the necessary resources (e.g. the power levels or the specific resource blocks used). PSC typically takes into account the QoS requirements associated with RB:s, the channel quality information for UE:s, buffer status, interference situation, etc.

PSC is located in the eNodeB.

## 11.2.5 Inter-cell Interference Coordination (ICIC)

Inter-cell interference coordination has the task to manage radio resources (notably the radio resource blocks) such that inter-cell interference is kept under control. The specific ICIC techniques that will be used in E-UTRA are decided by RAN1.

ICIC is inherently a multi-cell RRM function that needs to take into account information (e.g. the resource usage status and traffic load situation) from multiple cells. The optimal placement of ICIC will also depend on the specific ICIC technique.

## 11.2.6 Load Balancing (LB)

Load balancing has the task to handle uneven distribution of the traffic load over multiple cells. The purpose of LB is thus to influence the load distribution in such a manner that radio resources remain highly utilized and the QoS of in-progress sessions are maintained to the extent possible. LB algorithms may result in hand-over decisions with the purpose of redistribute traffic from highly loaded cells to underutilized cells.

The placement of LB is in the eNodeB is possible.

## 11.2.7 Inter-RAT Radio Resource Management

Inter-RAT RRM is primarily concerned with the management of radio resources in connection with inter-RAT mobility, notably inter-RAT hand-over. At inter-RAT hand-over, the hand-over decision may take into account the involved RAT:s resource situation as well as UE capabilities and Operator policies. The importance of Inter-RAT RRM may depend on the specific scenario in which E-UTRAN is deployed.

The decision to initiate the inter-RAT HO for HOs towards non-LTE access is placed in the eNodeB.

## 11.3 RRM architecture in LTE

The RRM architecture for LTE is designed to support the RRM functions listed in the previous clause. Therefore, the function allocation to LTE nodes creates the basis for the architecture, including interfaces between nodes and the protocols to be used.

It is assumed that a logical E-UTRAN node in addition to the eNB is not needed for RRM purposes.

Moreover, due to the different usage of inter-cell RRM functionalities, each inter-cell RRM functionality should be considered separately in order to assess whether it should be handled in a centralised manner or in a distributed manner

The allocation of RRM functions, as indicated in the preceding Clause, in LTE is as follows:

### eNodeB:

- Radio Bearer Control
- Radio Admission Control
- Connection Mobility Control

- Packet Scheduling
- Load Balancing
- The decision to initiate the inter-RAT HO for HOs towards non-LTE access is placed in the eNodeB.

Inter-cell Interference Coordination can, depending on outcome of further more detailed studies, be decided to be realized as anything from an implementation specific matter (e.g. more static schemes – like "planning") to completely distributed schemes operating on fully specified interfaces. Factors to weight into such decision can be for example expected performance gain, required update frequency, and expected implementation accuracy.

## 11.4 Support of load sharing and policy management across different Radio Access Technologies (RATs)

The E-UTRAN architecture will support load sharing across RATs.

# 12 System and terminal complexity

## 12.1 Over all system complexity

A key requirement of E-UTRAN is to maintain the complexity at a reasonable level. Although no firm analysis on the final complexity has been performed, in this respect the following decisions have been taken:

Decreased complexity:

- The number of transport channels is reduced compared to UTRAN, by making use of shared channels and not supporting dedicated transport channels.
- The number of different MAC entities is reduced compared to UTRAN (e.g. MAC-d not needed in the absence of dedicated transport channels).
- The BMC layer and the CTCH of UTRAN are not needed in E-UTRAN, i.e. all data broadcast is on MBMS and on e.g. MTCH.
- There is no inter-eNB SHO in the downlink and in the uplink (as currently supported for Rel-6 dedicated channels in UTRAN) for the shared channel, in case of unicast transmissions.
- Compressed mode as defined for UTRAN is not supported. If some transmission/reception gaps for measurement purpose have to be provided to the UE, this will be based on scheduling gaps.
- RRC is simplified by e.g. reducing the number of RRC states compared to UTRAN (e.g. removal of UTRAN CELL\_FACH is agreed).

Increased complexity:

- Minimum UE bandwidth capability is smaller than largest cell bandwidths.
- RAN1 assumes SFN operation for efficient broadcast which requires synchronised network operation.

## 12.2 Physical layer complexity

Overall, no issue has been raised that would indicate that physical layer complexity would be unacceptably high and it can thus be concluded that E-UTRA implementation is feasible from a physical layer perspective.

The E-UTRA system will provide significantly higher data rates than Release 6 WCDMA and, as a consequence hereof, the physical layer complexity will increase accordingly compared to lower-rate systems. The increase in data rate is achieved through higher transmission bandwidth and/or support for MIMO and will have complexity impacts such as:

- higher channel decoding capacity

- larger soft buffer sizes for HARQ processing.

This complexity is not seen as E-UTRA specific, but is similar to the complexity experienced in any high data rate system.

One of the advantages of an OFDM/SC-FDMA based system is that it allows for implementation of a lower complexity receiver at wider bandwidths. Another advantage is the possibility of operating MBMS in a single frequency network manner where significant performance gains can be achieved with no additional complexity increase in the UE receiver (see clause 12.3).

E-UTRA will support multiple bandwidth options ranging from 1.25 to 20 MHz and both FDD and TDD modes. The variable bandwidth options has a complexity impact, however with proper channel structures, e.g., designing control channels such that decoding is invariant to the transmission bandwidth, limited additional complexity due to the multiple bandwidths has been identified. Support for both FDD and TDD modes is not expected to have major complexity impact provided that maximum commonality between the two modes is maintained.

Based on what was seen as acceptable increase in complexity, it has been decided that all UEs shall have a reception- and transmission-bandwidth capability of at least 10 MHz. Limiting the bandwidth to 10 MHz creates challenges in mobility measurements when 10 MHz UEs are receiving data from cells with 20 MHz operating bandwidth, but these problems are solvable with a limited complexity impact.

To the extent possible, the design of E-UTRA has been done with the aim of reducing the number of unnecessary options in order to simplify implementation and testing.

## 12.3 UE complexity

With the progress of technology over time, some of the complexity restrictions may no longer apply, and allow reconsideration regarding addition of functionalities currently considered to be too complex, as well as functionalities currently not considered, in a later Release of the specification. However, if new functionalities are considered in the future, incremental gains that these additions could provide should also be evaluated.

The document [9] introduced and proposed the following set of resource aggregation options for E-UTRA.

- Resource aggregation type 1 - over adjacent channels in the same band with same content
- Resource aggregation type 2 - over separated channels in the same band with same content
- Resource aggregation type 3 - over separated channels in different bands with same content
- Resource aggregation type 4 - DL broadcast channel and bidirectional channel in the same band
- Resource aggregation type 5 - DL broadcast channel and bidirectional channel in the different bands

RAN4 has analysed the feasibility and necessity of these different resource aggregation options.

It was recognised in [9] that there may be benefits of having aggregation for different kinds of spectrum allocations for the operators. However, it was also considered in a RAN4 document\* that E-UTRA complexity compared to UTRA is already increased due to e.g. scalable bandwidths. It is also pointed out in the RAN4 document\* that the uplink and downlink parts of each type of resource aggregation have different implementation impacts and should be considered separately. The position of different aggregated carriers affects RF implementation and related complexity. However, as discussed in the RAN4 document\* from an RF implementation point-of-view, it does not matter for the downlink whether two aggregated resources support unicast data, broadcast data or any combination of these two.

Resource aggregation types 1-3 have been discussed and analysed in several RAN4 documents\*.

**Type1:** It was considered in a RAN4 document\* that instead of using resource aggregation a wider bandwidth carrier on a contiguous spectrum allocation would offer lower complexity and better performance allowed by advanced network algorithms like frequency domain scheduling. The presented simulation results in a RAN4 document\* indicated that the transmission of multiple SC-FDMA channels is significantly more inefficient from the PA perspective than the transmission of one wider bandwidth channel because PAR/CM levels would be higher for the transmission of multiple bandwidth channels meaning that at least in the uplink it is likely that there would be further specification impacts in terms of complexity of the RAN4 ACLR/emission requirements.

**Type2:** As stated in a RAN4 document\* it is seen to be more efficient to improve the performance of data reception on one operating bandwidth rather than increasing UE complexity for supporting resource aggregation of the same content



on more than one bandwidth. As for the type 1 also in this case at least in the uplink there would be further specification impacts in terms of complexity of the RAN4 ACLR/emission requirements. There are also impacts to the NB scheduler design and corresponding signalling.

**Type3:** With the resource aggregation of the same content over different band, in addition to UE complexity issues network planning issues (i.e. cell borders and sites being at different locations) were considered more challenging in RAN4 document\*, which would lead to more complicated RRM and network signalling. There are also UL specification impacts and issues in terms of spurious emissions requirements.

#### **Conclusions on resource aggregation with same content**

Based on the findings of several RAN4 documents\* and RAN4 discussions, it is proposed to avoid resource aggregation for the same content (types 1, 2, and 3). The concerns raised in [9] are addressed as the minimum UE UL and DL bandwidth capabilities are agreed to be 10 MHz. Additionally terminals will support all bandwidth options within its bandwidth capability. Hence, this should give operators some flexibility in terms of channel arrangements.

**Type 4&5:** The MBMS targets for the E-UTRA system in [4] indicate that some level of resource aggregation is probably needed for providing unicast and MBMS services simultaneously due to a requirement for a possibility to deploy MBMS on separate carrier. Both Type 4 and Type 5 are considered feasible. Complexity level depends on frequency separation.

#### **Conclusions on resource aggregation with bi-directional and broadcast channels**

Based on the MBMS requirements in [4] and the recommendations on the resource aggregation of bi-directional and broadcast channels in several RAN4 documents\*, it is proposed that the resource aggregation of bi-directional and broadcast channels is considered further when developing the E-UTRA specifications in the work item phase.

#### **UE complexity issues related to the UE maximum output power**

A RAN4 document\* considered UE complexity issues related to the UE maximum output power. The document concluded that it should be possible to reuse the rel-6 PA in order to allow for a single PA implementation for multi-mode (E-UTRA, UTRA) and multi-band terminals and that the E-UTRA UE power class should be a subset of the current UTRA Rel-6 power classes.

#### **Conclusions on UE output power**

It is proposed to consider the outcome of RAN1 analyses on coverage and cell edge performance before concluding the UE maximum output power requirements.

Note: \*See clause 5.3 in [8]

---

## 13 Performance assessments

### 13.1 Peak data rate

The estimated peak rates deemed feasible with E-UTRA are summarized in table 13.1 and table 13.2 for FDD and TDD. For both uplink and downlink, it was found that achieving and even exceeding the peak rate requirements outlined in [4] is feasible. This is based on a preliminary layer 1 and layer 2 control overhead as well as realistic assumptions on the highest modulation order which can be used in the most favorable WAN environments.

**Table 13.1: DL Peak rates for E-UTRA FDD/TDD (frame structure type 1)**

	<b>Downlink</b>	
Assumptions	64 QAM, R=1 Signal overhead for reference signals and control channel occupying one OFDM symbol	
Unit	Mbps in 20 MHz	b/s/Hz
Requirement	100	5.0
2x2 MIMO	172.8	8.6
4x4 MIMO	326.4	16.3

**Table 13.1a: UL Peak rates for E-UTRA FDD/TDD frame structure type 1**

	<b>Uplink</b>	
Assumptions	Single TX UE, R=1 Signal overhead for reference signals and control channel occupying 2RB	
Unit	Mbps in 20 MHz	b/s/Hz
Requirement	50	2.5
16QAM	57.6	2.9
64QAM	86.4	4.3

**Table 13.2: Peak rates for E-UTRA TDD (TDD frame structure type 2)**

	<b>Downlink</b>		<b>Uplink</b>	
Assumptions	64 QAM, R=1 frame structure type 2		Single TX UE, 64 QAM, R=1 frame structure type 2	
Unit	Mbps in 20 MHz	b/s/Hz	Mbps in 20 MHz	b/s/Hz
Requirement	100	5.0	50	2.5
2x2 MIMO in DL	142	7.1	62.7	3.1
4x4 MIMO in DL	270	13.5		

## 13.2 C-plane latency

Figure 13.1 provides an example C-plane flow for the LTE\_IDLE to LTE\_ACTIVE transition in LTE/SAE and is based on the procedure described in sub-clause 7.14.2 of [3].

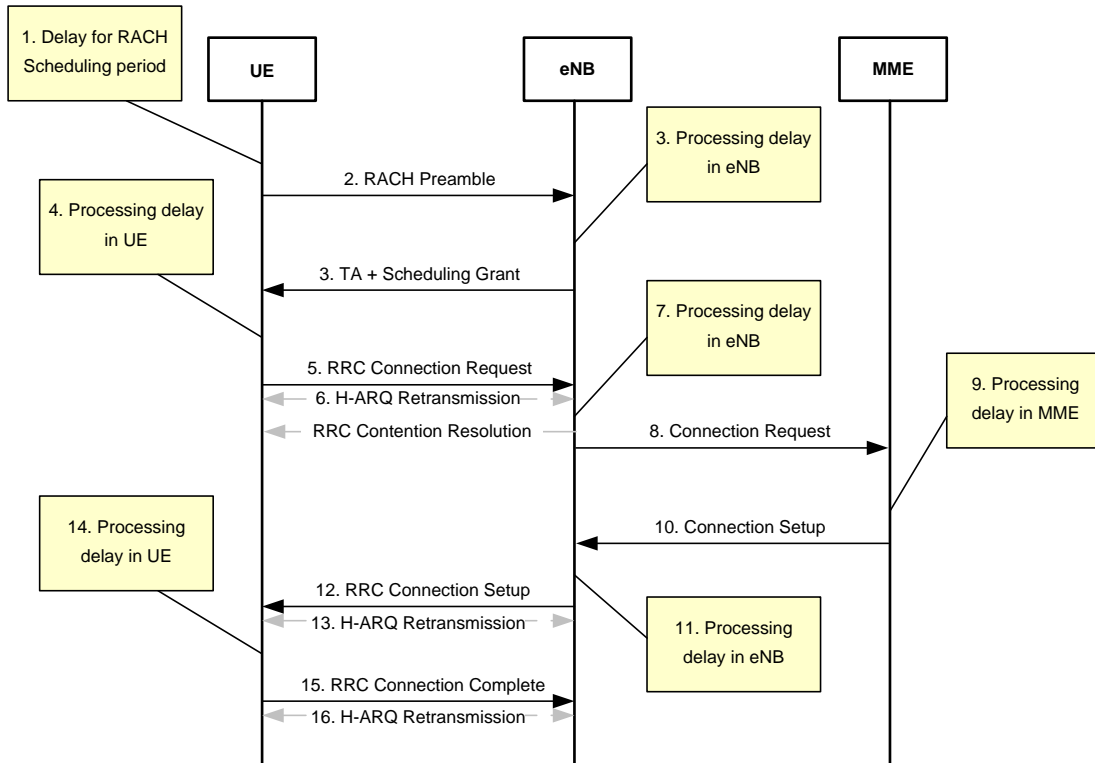

**Figure 13.1: C-plane activation procedure (example)**

NOTE: The RRC Contention Resolution message (between steps 7 and 8) does not contribute to the overall state transition latency and is therefore not included in the analysis.

### 13.2.1 FDD frame structure

Tables 13.3 and 13.3a provide a timing analysis, assuming FDD frame structure, of the flow depicted in Figure 13.1. The analysis illustrates that the requirement for the state transition from LTE\_IDLE to LTE\_ACTIVE can be achieved within the 100ms requirement.

**Table 13.3: C-plane latency analysis (based on the procedure depicted in Figure 13.1)**

Step	Description	Duration
0	UE wakeup time	Implementation dependent – Note included
1	Average delay due to RACH scheduling period	5ms
2	RACH Preamble	1ms
3	Preamble detection and transmission of RA response (Time between the end RACH transmission and UE's reception of scheduling grant and timing adjustment)	5ms
4	UE Processing Delay (decoding of scheduling grant, timing alignment and C-RNTI assignment + L1 encoding of RRC Connection Request)	2.5ms
5	TTI for transmission of RRC Connection Request	1ms
6	HARQ Retransmission (@ 30%)	0.3 *5ms
7	Processing delay in eNB (Uu → S1-C)	4ms
8	S1-C Transfer delay	Ts1c (2ms – 15ms)
9	MME Processing Delay (including UE context retrieval of 10ms)	15ms
10	S1-C Transfer delay	Ts1c (2ms – 15ms)
11	Processing delay in eNB (S1-C → Uu)	4ms
12	TTI for transmission of RRC Connection Setup (+Average alignment)	1.5ms
13	HARQ Retransmission (@ 30%)	0.3 *5ms
14	Processing delay in UE	3ms
15	TTI for transmission of L3 RRC Connection Complete	1ms
16	HARQ Retransmission (@ 30%)	0.3 *5ms
	<b>Total LTE_IDLE → ACTIVE delay (C-plane establishment)</b>	<b>47.5ms + 2 * Ts1c</b>

**Table 13.3a: U-plane establishment latency**

Step	Description	Duration
	LTE_IDLE→LTE_ACTIVE delay (C-plane establishment)	47.5ms + 2 * Ts1c
17	TTI for UL DATA PACKET (Piggy back scheduling information)	1ms
18	HARQ Retransmission (@ 30%)	0.3 * 5ms
19	eNB Processing Delay (Uu → S1-U)	1ms
	<b>U-plane establishment delay (RAN edge node)</b>	<b>51ms + 2 * Ts1c</b>
20	S1-U Transfer delay	Ts1u (1ms – 15ms)
21	UPE Processing delay (including context retrieval)	10ms
	<b>U-plane establishment delay (Serving GW)</b>	<b>61ms + 2 * Ts1c + Ts1u</b>

Note 1: The figures included in Steps 8, 9, 10, 20 and 21 are outside the scope of RAN WG2.

Note 2: The S1-C transfer delay is estimated to be longer than the S1-U transfer delay, since more reliable L2 protocol stack is assumed for S1-C.

Note 3: For procedural aspects which remain to be agreed in RAN WG2, the analysis contains preliminary assumptions.

## 13.2.2 TDD frame structure type 1

Table 13.3b provides a timing analysis, assuming TDD frame structure 1 with different frame formats as shown in Figure 13.1a. The analysis illustrates that the requirement for the state transition from LTE\_IDLE to LTE\_ACTIVE can be achieved within the 100ms requirement.

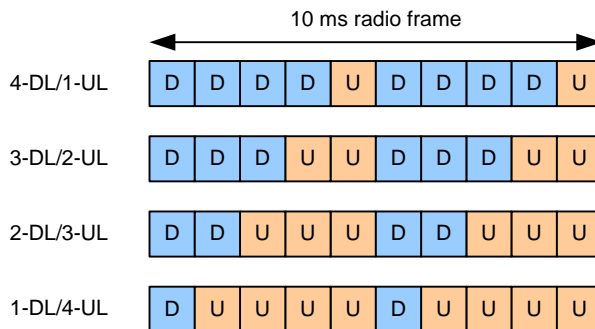

Figure 13.1a: TDD frame formats

Table 13.3b: C-plane latency analysis for TDD frame structure 1 (based on the procedure depicted in Figure 13.1)

Step	Description	4-DL/1-UL	3-DL/2-UL	2-DL/3-UL	1-DL/4-UL
0	UE wakeup time	Implementation dependent – Not included			
1	Average delay due to RACH scheduling period	5ms	5ms	5ms	5ms
2	RACH Preamble	1ms	1ms	1ms	1ms
3	Preamble detection and transmission of RA response (Time between the end RACH transmission and UE's reception of scheduling grant and timing adjustment)	6ms	6ms	6ms	6ms
4	UE Processing Delay (decoding of scheduling grant, timing alignment and C-RNTI assignment + L1 encoding of RRC Connection Request )	3ms	3ms	3ms	3ms
5	TTI for transmission of RRC Connection Request	1ms	1ms	1ms	1ms
6	HARQ Retransmission (@ 30%)	0.3*5ms	0.3*4.5ms	0.3*4.33ms	0.3 * 5.75ms
7	Processing delay in eNB (Uu → S1-C)	4ms	4ms	4ms	4ms
8	S1-C Transfer delay	Ts1c (2ms – 15ms)	Ts1c (2ms – 15ms)	Ts1c (2ms – 15ms)	Ts1c (2ms – 15ms)
9	MME Processing Delay (including UE context retrieval of 10ms)	15ms	15ms	15ms	15ms
10	S1-C Transfer delay	Ts1c (2ms – 15ms)	Ts1c (2ms – 15ms)	Ts1c (2ms – 15ms)	Ts1c (2ms – 15ms)
11	Processing delay in eNB (S1-C → Uu)	4ms	4ms	4ms	4ms
12	TTI for transmission of RRC Connection Setup (+Average alignment)	1.7ms	2.1ms	2.7ms	3.5ms
13	HARQ Retransmission (@ 30%)	0.3*5.75ms	0.3*4.33ms	0.3*4.5ms	0.3 *5ms
14	Processing delay in UE	3ms	3ms	3ms	3ms
15	TTI for transmission of L3 RRC Connection Complete (+Average alignment)	3.5ms	2.7ms	2.1ms	1.7ms
16	HARQ Retransmission (@ 30%)	0.3*5ms	0.3*4.5ms	0.3*4.33ms	0.3 * 5.75ms
	<b>Total LTE_IDLE→LTE_ACTIVE delay (C-plane establishment)</b>	<b>51.925 + 2*Ts1c</b>	<b>50.799 + 2*Ts1c</b>	<b>50.748 + 2*Ts1c</b>	<b>52.15 + 2*Ts1c</b>

**Table 13.3c: U-plane establishment latency**

Step	Description	4-DL/1-UL	3-DL/2-UL	2-DL/3-UL	1-DL/4-UL
	LTE_IDLE→LTE_ACTIVE delay (C-plane establishment)	51.925 + 2*Ts1c	50.799 + 2*Ts1c	50.748 + 2*Ts1c	52.15 + 2*Ts1c
17	TTI for UL data packet + average alignment (Piggy back scheduling information)	3.5ms	2.7ms	2.1ms	1.7ms
18	HARQ Retransmission (@ 30%)	0.3*5ms	0.3*4.5ms	0.3*4.33ms	0.3 * 5.75ms
19	eNB Processing Delay (Uu → S1-U)	1ms	1ms	1ms	1ms
	<b>U-plane establishment delay (RAN edge node)</b>	<b>57.925 + 2*Ts1c</b>	<b>55.849 + 2*Ts1c</b>	<b>54.148 + 2*Ts1c</b>	<b>56.575 + 2*Ts1c</b>
20	S1-U Transfer delay	Ts1u (1ms – 15ms)	Ts1u (1ms – 15ms)	Ts1u (1ms – 15ms)	Ts1u (1ms – 15ms)
21	UPE Processing delay (including context retrieval)	10ms	10ms	10ms	10ms
	<b>U-plane establishment delay (Serving GW)</b>	<b>67.925 + 2*Ts1c + Ts1u</b>	<b>65.849 + 2*Ts1c + Ts1u</b>	<b>64.148 + 2*Ts1c + Ts1u</b>	<b>66.575 + 2*Ts1c + Ts1u</b>

### 13.2.3 TDD frame structure type 2

The C-plane establishment latency analysis for TDD frame structure 2 is summarised in table 13.3d.

**Table 13.3d: C-plane establishment latency analysis (based on the procedure depicted in Figure 13.1)**

Step	Description	Duration
0	UE wakeup time	Implementation dependent – Not included
1	Average delay due to RACH scheduling period	2.5ms
2	RACH Preamble	0.95ms
3	Preamble detection and transmission of RA response (Time between the end RACH transmission and UE's reception of scheduling grant and timing adjustment)	7.025ms
4	UE Processing Delay (decoding of scheduling grant, timing alignment and C-RNTI assignment + L1 encoding of RRC Connection Request)	2.3ms
5	TTI for transmission of RRC Connection Request	0.675ms
6	HARQ Retransmission (@ 30%)	0.3 * 5ms
7	Processing delay in eNB (Uu → S1-C)	4ms
8	S1-C Transfer delay	Ts1c (2ms – 15ms)
9	MME Processing Delay (including UE context retrieval of 10ms)	15ms
10	S1-C Transfer delay	Ts1c (2ms – 15ms)
11	Processing delay in eNB (S1-C → Uu)	4ms
12	TTI for transmission of RRC Connection Setup (+Average alignment)	2.163ms
13	HARQ Retransmission (@ 30%)	0.3 * 5ms
14	Processing delay in UE	2.975ms
15	TTI for transmission of L3 RRC Connection Complete	0.675ms
16	HARQ Retransmission (@ 30%)	0.3 * 5ms
	<b>Total LTE_IDLE→LTE_ACTIVE delay (C-plane establishment)</b>	<b>46.763ms + 2 * Ts1c</b>

For TDD frame structure type 2, U-plane establishment delay data was not available at the time of writing.

## 13.3 U-plane latency

The requirement on U-plane latency in clause 6.2.2 of TR 25.913 [4] reads as follows:

**"U-Plane Delay Definition** – U-plane delay is defined in terms of the one-way transit time between a packet being available at the IP layer in either the UE/RAN edge node and the availability of this packet at IP layer in the RAN edge node/UE. The RAN edge node is the node providing the RAN interface towards the core network.

Specifications shall enable an E-UTRA U-plane latency of less than 5 ms in unload condition (i.e. single user with single data stream) for small IP packet, e.g. 0 byte payload + IP headers E-UTRAN bandwidth mode may impact the experienced latency

Note: This requirement, more specifically the exact definition of latency, may be revisited and further clarified once there is a 3GPP system end-to-end requirement agreed and the overall system architecture is settled, including the RAN and core network functional split. This means that the network entities between which the U-plane latency requirement of E-UTRA and E-UTRAN applies, will finally be defined at a later stage."

With PDCP terminated in the eNB, it is understood that the RAN edge node is the eNB. The U-plane assessment assumes, in accordance with the requirement, unload conditions where scheduling delays are negligible. Further, it is assumed that a valid scheduling grant is available; i.e. no random access procedure needs to be performed.

### 13.3.1 FDD frame structure

The LTE U-plane delay consists of node processing delays, TTI duration, and radio frame alignment. The delay components are summarised in Figure 13.2.

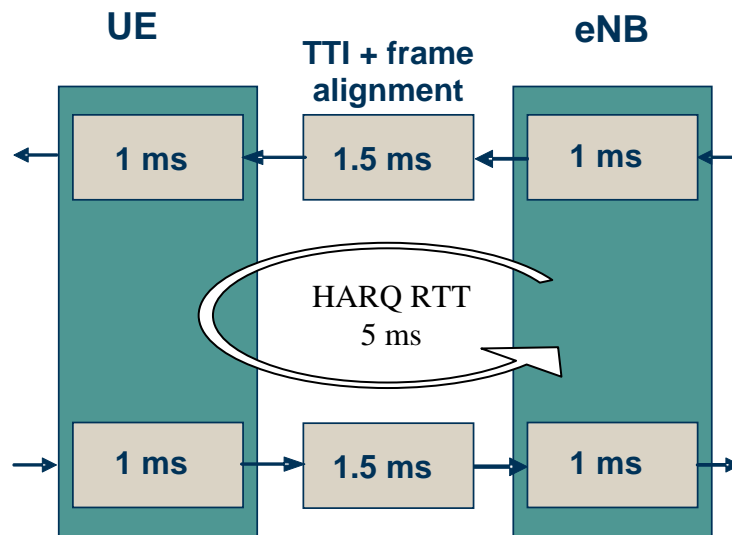

**Figure 13.2: U-plane latency components in LTE**

Based on the assumptions above, the LTE U-plane latency can be written:

$$D_{UP} [\text{ms}] = 1 + 1.5 + 1 + n * 5 = 3.5 + n * 5,$$

where n is the number of HARQ re-transmissions. In typical cases there would be 0 or 1 re-transmissions yielding an approximate average U-plane latency of

$$D_{UP, \text{typical}} [\text{ms}] = 3.5 + p * 5,$$

where p is the error probability of the first HARQ transmission. Hence the U-plane latency is a function of the HARQ operating point. Table 13.4 shows the U-plane latency when HARQ is operated at an initial transmission error probability of 0.0 and 0.3, respectively.

**Table 13.4: U-plane latency analysis (estimated average)**

Step	Description	Value (0% HARQ)	Value (30% HARQ)
0	UE wakeup time	Implementation dependent – Not included	Implementation dependent – Not included
1	UE Processing Delay	1ms	1ms
2	Frame Alignment	0.5ms	0.5ms
3	TTI for UL DATA PACKET (Piggy back scheduling information)	1 ms	1 ms
4	HARQ Retransmission	0 ms	0.3*5ms
5	eNB Processing Delay (Uu → S1-U)	1ms	1ms
	<b>Total one way delay</b>	<b>3.5ms</b>	<b>5ms</b>

Note: While table 13.4 illustrates the U-plane latency for the UL, the indicated latencies, although applied in a different order, should be understood as representative also for the DL.

For FDD frame structure, it is concluded that for a typical case with an initial HARQ error rate of 0.0 and 0.3, total average U-plane latencies of 3.5ms and 5.0ms, respectively, can be achieved.

### 13.3.2 TDD frame structure type 1

The LTE U-plane delay consists of node processing delays, TTI duration, radio frame alignment and S1-U delay. The delay components are summarised in Figure 13.2a for TDD.

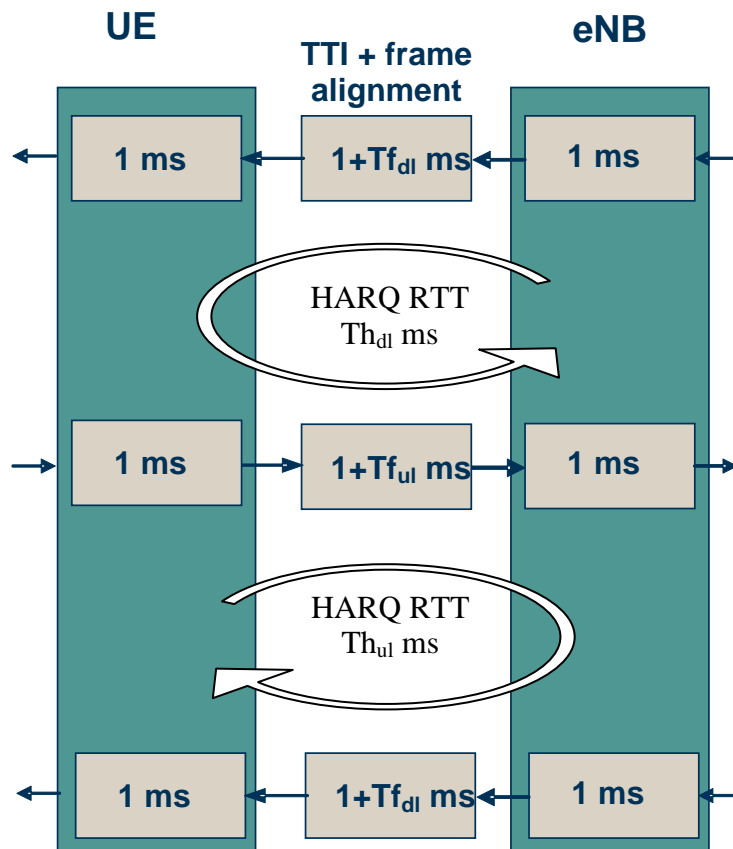

**Figure 13.2a: U-plane latency components in TDD**

Where

$T_{h,dl}$ : average HARQ RTT in downlink

$T_{f,dl}$ : average frame alignment delay in downlink

$T_{h,ul}$ : average HARQ RTT in uplink



$T_{f_{ul}}$ : average frame alignment delay in uplink

Based on the assumptions above, the LTE U-plane latency can be written:

$$D_{UP} [\text{ms}] = 1 + 1 + T_f + 1 + n * T_h$$

where  $T_f$  is the frame alignment delay,  $T_h$  is the HARQ RTT and  $n$  is the number of HARQ re-transmissions. As indicated above,  $T_f$  and  $T_h$  can be different for ulink and downlink. In typical cases there would be 0 or 1 re-transmissions yielding an approximate average U-plane latency of

$$D_{UP, \text{typical}} [\text{ms}] = 3 + T_f + p * T_h,$$

where  $p$  is the error probability of the first HARQ transmission. Hence the U-plane latency is a function of the HARQ operating point. Tables 13.4a and 13.4b show the U-plane latency in downlink and uplink, respectively, for different TDD frame formats when no HARQ retransmission is assumed for the first transmission.

**Table 13.4a: U-plane latency analysis with 0% HARQ (estimated average in downlink)**

Step	Description	4-DL/1-UL	3-DL/2-UL	2-DL/3-UL	1-DL/4-UL
0	UE wakeup time	Implementation dependent – Not included			
1	UE Processing Delay	1ms	1ms	1ms	1ms
2	Frame Alignment	0.7ms	1.1ms	1.7ms	2.5ms
3	TTI for UL DATA PACKET (Piggy back scheduling information)	1ms	1ms	1ms	1ms
4	HARQ Retransmission	0ms	0ms	0ms	0ms
5	eNB Processing Delay (Uu → S1-U)	1ms	1ms	1ms	1ms
	<b>Total one way delay</b>	<b>3.7ms</b>	<b>4.1ms</b>	<b>4.7ms</b>	<b>5.5ms</b>

**Table 13.4b: U-plane latency analysis with 0% HARQ (estimated average in uplink)**

Step	Description	4-DL/1-UL	3-DL/2-UL	2-DL/3-UL	1-DL/4-UL
0	UE wakeup time	Implementation dependent – Not included			
1	UE Processing Delay	1ms	1ms	1ms	1ms
2	Frame Alignment	2.5ms	1.7ms	1.1ms	0.7ms
3	TTI for UL DATA PACKET (Piggy back scheduling information)	1ms	1ms	1ms	1ms
4	HARQ Retransmission	0ms	0ms	0ms	0ms
5	eNB Processing Delay (Uu → S1-U)	1ms	1ms	1ms	1ms
	<b>Total one way delay</b>	<b>5.5ms</b>	<b>4.7ms</b>	<b>4.1ms</b>	<b>3.7ms</b>

Analysis shows that the 5ms U-plane latency requirement may be simultaneously satisfied in TDD for both uplink and downlink using the 2-DL/3-UL and 3-DL/2-UL framing structures with no re-transmission assumed for the first transmission.

### 13.3.3 TDD frame structure type 2

Tables 13.4c and 13.4d show the U-plane latency in downlink and uplink, respectively, for a 4-DL/3-UL configuration of TDD frame structure 2.

**Table 13.4c: U-plane latency analysis (estimated average in downlink)**

Step	Description	Value (0% HARQ)	Value (30% HARQ)
0	UE wakeup time	Implementation dependent – Not included	Implementation dependent – Not included
1	eNB Processing Delay (S1-U->Uu)	1ms	1ms
2	Frame Alignment	1.022ms	1.022ms
3	TTI for DL DATA PACKET	0.675ms	0.675ms
4	HARQ Retransmission	0ms	0.3*5ms
5	UE Processing Delay	1ms	1ms
	<b>Total one way delay</b>	<b>3.697ms</b>	<b>5.197ms</b>

**Table 13.4d: U-plane latency analysis (estimated average in uplink)**

Step	Description	Value (0% HARQ)	Value (30% HARQ)
0	UE wakeup time	Implementation dependent – Not included	Implementation dependent – Not included
1	UE Processing Delay	1ms	1ms
2	Frame Alignment	1.423ms	1.423ms
3	TTI for UL DATA PACKET (Piggy back scheduling information)	0.675ms	0.675ms
4	HARQ Retransmission	0ms	0.3*5ms
5	eNB Processing Delay (Uu -> S1-U)	1ms	1ms
	<b>Total one way delay</b>	<b>4.098ms</b>	<b>5.598ms</b>

In TDD frame structure type 2, the requirements on U-plane delay can be reached.

## 13.4 User throughput

### 13.4.1 Fulfilment of uplink user-throughput targets

#### 13.4.1.1 Initial performance evaluation

According to [4], the agreed target for the LTE radio-access concept in terms of average and cell-edge user throughput are 2-3 times gain compared to the baseline configuration.

Multiple evaluations that directly evaluate the uplink system performance of the LTE concept vs. the baseline configuration have been carried out. The evaluations have been carried out by different sources/companies and for different scenarios, something that provides a certain degree of diversity in the evaluation results.

- In terms of average user throughput, the results indicate gains vs. the baseline configuration also ranging from around 2 times to above 3 times.
- In terms of cell-edge user throughput, the results indicate gains vs. the baseline configuration ranging from around 2 times to, in some cases, well above 3 times.

It should be pointed out that some proposed and considered LTE features, such as the possibility for a variable TTI for overhead/delay optimization and different schemes for interference mitigation, have not been included in all of the evaluations. Thus there is a potential for further LTE uplink performance enhancements.

Based on this, one can conclude that the LTE SC-FDMA-based uplink as currently defined includes the features needed to fulfil the agreed targets on uplink user throughput.

#### 13.4.1.2 UL user throughput performance evaluation

According to evaluation metric and assumption in [10], multiple evaluations that directly evaluate the uplink system performance of the LTE concept vs. the baseline configuration have been carried out. Efforts have been made to use realistic physical and link layer model. Further, fairness and coverage aspects are controlled through not only measuring average performance, but also cell-edge performance. The evaluations have been carried out by different sources/companies and for different scenarios. For both the baseline UTRA and E-UTRA results, the average cell

throughput figures match well between companies. Summaries of the results for simulation cases 1 and 3 are presented in Table 13.4e and Table 13.4f, respectively. The figures for each system concept and metric have been obtained by averaging the results presented in the individual input papers. It can be seen that the requirements given in [4] are met, i.e. 2-3 times improvement in cell user throughputs.

**Table 13.4e: UL user throughput performance for Case 1(500m ISD)**

	Mean User Throughput	Cell-Edge User Throughput
Case 1	x UTRA	x UTRA
UTRA baseline	x1.0	x1.0
E-UTRA 1x2	x2.2	x2.5
E-UTRA 1x4	x3.3	x5.5
E-UTRA 2x2 SU-MIMO	x2.3	x1.1

**Table 13.4f: UL user throughput performance for Case 3(1732m ISD)**

	Mean User Throughput	Cell-Edge User Throughput
Case 3	x UTRA	x UTRA
UTRA baseline	x1.0	x1.0
E-UTRA 1x2	x2.2	x2.0
E-UTRA 1x4	x3.3	x4.2

## 13.4.2 Fulfilment of downlink user-throughput targets

### 13.4.2.0 Initial performance evaluation

According to [4], the agreed targets for the LTE radio-access concept in terms of average and cell-edge user throughput are 3-4 times gain and 2-3 times gain vs. the baseline configuration defined in [4], respectively.

Multiple evaluations that directly evaluate the downlink system performance of the LTE concept vs. the baseline configuration have been carried out. The evaluations have been carried out by different sources/companies and for different scenarios, something that provides a certain degree of diversity in the evaluation results.

Evaluations have been carried out both assuming that MIMO is used in case of LTE evaluation(s) and that MIMO is not used in case of the LTE evaluation(s). As expected, including MIMO in the evaluations provide higher LTE system performance. It should be pointed out that including MIMO for LTE is inline with the agreed assumptions in [4].

- All evaluations indicate that the LTE concept fulfils the agreed target for cell-edge throughput, assuming a lower-speed (3 km/h) scenario.
- In terms of average user throughput, the evaluation indicate that the LTE concept fulfils or is very close (within 10%) to the agreed target.

Based on these evaluations one cannot directly conclude that the LTE concept fulfils the LTE downlink user-throughput targets. However, these evaluations do not include all the features that are suggested to be part of the LTE radio-access concept, most notably different schemes for more advanced interference mitigation (e.g. interference coordination and/or cancellation) and variable TTI for overhead/delay optimization. Adding the potential gains of this to the above summarized gains would indicate that the LTE downlink radio-access concept can fulfil the agreed user-throughput targets.

More information can be found in clause 8 of [2].

### 13.4.2.1 Fulfilment of downlink user-throughput targets by enhancement techniques

Multiple evaluations that directly evaluate the gains of downlink system performance of the LTE concept with enhancement techniques have been carried out. Specifically, the enhancement techniques are longer TTI, static

interference coordination, interference cancellation adaptive antenna schemes and semi-static interference coordination. The evaluations have been carried out by different sources/companies and for different scenarios, something that provides a certain degree of diversity in the evaluation results. Each technique can improve both average user throughput and 5%-tile user throughput performance by at least 10%.

Without performing simulations including, at same time, all these techniques, it is somewhat difficult to conclude on exact cumulative gain figures for all the techniques. However it is likely that with these techniques included in LTE specification and implementation, at least 3.5x gain in sector spectral efficiency together with at least 3x gain in 5% -tile user throughput can be achieved. There is the potential, considering some of the simulation results, that even higher gains could be achieved.

Note that these gains can be achieved simultaneously with corresponding gains in spectral efficiency (system throughput), see subclause 13.5.2.1.

More information can be found in clause 8 of [2].

#### 13.4.2.1.1 Performance Enhancement by Additional Transmit Antennas: 4 Transmit Antennas

Multiple evaluations that directly evaluate the gains of downlink system performance of the LTE concept with additional TX and RX antennas (up to four antennas) have been carried out. The evaluations have been carried out by different sources/companies and for different scenarios, something that provides a certain degree of diversity in the evaluation results.

- Additional gain of 4x2 antenna vs. 2x2 antenna LTE is more than 10%.
- Additional gain of 4x4 antenna vs. 2x2 antenna LTE is more than 60%.

Based on these evaluations, one can draw the conclusion that additional antennas can improve both average and 5% -tile downlink user throughput significantly

More information can be found in clause 8 of [2].

#### 13.4.2.2 DL user throughput performance evaluation

According to evaluation metric and assumption in [10], multiple evaluations that directly evaluate the downlink system performance of the LTE concept vs. the baseline configuration have been carried out. Efforts have been made to use realistic physical and link layer model. Further, fairness and coverage aspects are controlled through not only measuring average performance, but also cell-edge performance. The evaluations have been carried out by different sources/companies and for different scenarios, something that provides a certain degree of diversity in the evaluation results. Summaries of the results for simulation cases 1 and 3 are presented in Table 13.4g and 13.4h respectively. For E-UTRA, results are presented both for the 2x2 ( $N_{tx} \times N_{rx}$  antennas) reference configuration, as well as for the enhanced 4x2 and 4x4 configurations. The figures for each system concept and metric have been obtained by averaging the results presented in the individual input papers. It can be seen that the requirements given in [4] are met, i.e. 3-4 times improvement in average user throughputs, and 2-3 times improvement in cell-edge user throughput

**Table 13.4g: DL user throughput performance for Case 1 (500m ISD).**

Case 1	Mean User Throughput	Cell-Edge User Throughput
	x UTRA	x UTRA
UTRA baseline 1x2	x1,0	x1,0
E-UTRA 2x2 SU-MIMO	x3,2	x2,7
E-UTRA 4x2 SU-MIMO	x3,5	x3,0
E-UTRA 4x4 SU-MIMO	x5,0	x4,4

**Table 13.4h: DL user throughput performance for Case 3 (1732m ISD).**

Case 3	Mean User Throughput	Cell-Edge User Throughput
--------	----------------------	---------------------------

	x UTRA	x UTRA
UTRA baseline 1x2	x1,0	x1,0
E-UTRA 2x2 SU-MIMO	x3,0	x2,3
E-UTRA 4x2 SU-MIMO	x3,6	x2,8
E-UTRA 4x4 SU-MIMO	x4,6	x4,8

## 13.5 Spectrum efficiency

### 13.5.1 Fulfilment of uplink spectrum-efficiency target

#### 13.5.1.1 Initial performance evaluation

According to [4], the agreed target for the LTE radio-access concept in terms of uplink spectrum efficiency is 2-3 times gain vs. the baseline configuration defined in [4].

Multiple evaluations that directly evaluate the uplink system performance of the LTE concept vs. the baseline configuration have been carried out. The evaluations have been carried out by different sources/companies and for different scenarios, something that provides a certain degree of diversity in the evaluation results. In terms of spectrum efficiency, the results of these evaluations indicate gains vs. the baseline configuration ranging from around 2 times to above 3 times.

The system performance for VoIP traffic has also been evaluated, and VoIP capacity of more than 3 times versus the baseline configuration defined in [4] has been observed.

It should be pointed out that some proposed and considered LTE features, such as the possibility for a variable TTI for overhead/delay optimization and different schemes for interference mitigation, have not been included in all of the evaluations. Thus there is a potential for further LTE uplink performance enhancements.

Based on this, one can conclude that the LTE SC-FDMA-based uplink as defined in clause 7.2 of this TR includes the features needed to fulfil the agreed targets on uplink spectrum efficiency.

#### 13.5.1.2 UL spectrum efficiency performance evaluation

According to evaluation metric and assumption in [10], multiple evaluations that directly evaluate the uplink system performance of the LTE concept vs. the baseline configuration have been carried out. Efforts have been made to use realistic physical and link layer model. Further, fairness and coverage aspects are controlled through not only measuring average performance, but also cell-edge performance. The evaluations have been carried out by different sources/companies and for different scenarios. For both the baseline UTRA and E-UTRA results, the spectrum efficiency figures match well between companies. Summaries of the results for simulation cases 1 and 3 are presented in Table 13.4i. The figures for each system concept and metric have been obtained by averaging the results presented in the individual input papers. It can be seen that the requirements given in [4] are met, i.e. 2-3 times improvement in spectrum efficiency

**Table 13.4i: UL spectrum efficiency performance for Case1 (500m ISD) and Case 3 (1732m ISD).**

	Case 1		Case 3	
	[bps/Hz/cell]	x UTRA	[bps/Hz/cell]	x UTRA
UTRA baseline	0.332	x1,0	0.316	x1.0
E-UTRA 1x2	0.735	x2.2	0.681	x2.2
E-UTRA 1x4	1.103	x3.3	1.038	x3.3
E-TURA 2x2 SU-MIMO	0.776	x2.3	-	-

## 13.5.2 Fulfilment of downlink spectrum-efficiency target

### 13.5.2.0 Initial performance evaluation

According to [4], the agreed target for the LTE radio-access concept in terms of downlink spectrum efficiency is 3-4 times gain vs. the baseline configuration defined in [4].

Multiple evaluations that directly evaluate the downlink system performance of the LTE concept vs. the baseline configuration have been carried out. The evaluations have been carried out by different sources/companies and for different scenarios, something that provides a certain degree of diversity in the evaluation results.

Evaluations have been carried out both assuming that MIMO is used for the case of LTE and that MIMO is not used for the case of LTE. It should be pointed out that the use of MIMO for LTE *is* inline with the agreed assumptions in [4].

Assuming MIMO most evaluations indicate that the LTE concept fulfils or are within approximately 10% of the agreed spectrum-efficiency target, assuming a lower-speed (3 km/h) scenario.

At higher UE speed (30 km/h), the performance gains are somewhat reduced which is also inline with the mobility requirement of [4], Clause 7.3.

The system performance for VoIP traffic has also been evaluated, and VoIP capacity of more than 3 times versus the baseline configuration defined in [4] has been observed.

Based on these evaluations one cannot directly conclude that the LTE concept fulfils the LTE downlink spectrum-efficiency target. However, these evaluations do not include all the features that are suggested to be part of the LTE radio-access concept, most notably different schemes for more advanced interference mitigation (e.g. interference coordination and/or cancellation) and variable TTI for overhead/delay optimization. Adding the potential gains of this to the above summarized gains would indicate that the LTE downlink radio-access concept can fulfil the agreed spectrum-efficiency targets.

More information can be found in clause 10 of [2].

### 13.5.2.1 Fulfilment of downlink spectrum-efficiency targets by enhancement techniques

Multiple evaluations that directly evaluate the gains of downlink system performance of the LTE concept with enhancement techniques have been carried out. Specifically, the enhancement techniques are longer TTI, static interference coordination, interference cancellation adaptive antenna scheme and semi-static interference coordination have been carried out. The evaluations have been carried out by different sources/companies and for different scenarios, something that provides a certain degree of diversity in the evaluation results. Each technique can improve the spectrum efficiency by at least 10% or more.

Without performing simulations including, at the same time, all these techniques it is somewhat difficult to conclude on exact cumulative gain figures for all the techniques. However it is likely that with these techniques included in LTE specification and implementation at least 3.5x gain in sector spectral efficiency can be achieved. There is the potential, considering some of the simulation results, that even higher gains could be achieved.

Note that these gains can be achieved simultaneously with corresponding gains in user throughput, see subclause 13.4.2.1.

More information can be found in clause 8 of [2].

### 13.5.2.2 DL spectrum efficiency performance evaluation

According to evaluation metric and assumption in [10], multiple evaluations that directly evaluate the downlink system performance of the LTE concept vs. the baseline configuration have been carried out. Efforts have been made to use realistic physical and link layer model. Further, fairness and coverage aspects are controlled through not only measuring average performance, but also cell-edge performance. The evaluations have been carried out by different sources/companies and for different scenarios, something that provides a certain degree of diversity in the evaluation results. Summaries of the results for simulation cases 1 and 3 are presented in Table 13.4j. For E-UTRA, results are presented both for the 2x2 ( $N_t \times N_r$  antennas) reference configuration, as well as for the enhanced 4x2 and 4x4 configurations. The figures for each system concept and metric have been obtained by averaging the results presented in

the individual input papers. It can be seen that the requirements given in [4] are met, i.e. 3-4 times improvement in spectrum efficiency

**Table 13.4j: DL spectrum efficiency performance for Case 1 (500m ISD) and Case 3 (1732m ISD).**

	Case 1		Case 3	
	[bps/Hz/cell]	x UTRA	[bps/Hz/cell]	x UTRA
UTRA baseline 1x2	0,53	x1,0	0,52	x1,0
E-UTRA 2x2 SU-MIMO	1,69	x3,2	1,56	x3,0
E-UTRA 4x2 SU-MIMO	1,87	x3,5	1,85	x3,6
E-UTRA 4x4 SU-MIMO	2,67	x5,0	2,41	x4,6

## 13.6 Mobility

### 13.6.1 Features supporting various mobile velocities

The E-UTRA supports seamless mobility across the cellular network; in RRC\_CONNECTED handovers are supported with resource preparations at the target cell, whereas in RRC\_IDLE the UE performs cell reselections and updates tracking areas. Inter-frequency mobility is also supported, hence making the E-UTRA flexible in supporting various deployment scenarios.

The E-UTRA is capable of supporting various mobile velocities. The main features that support efficient data transmission at various speeds are listed below.

- The subframe size of 0.5 ms makes the E-UTRA capable of adapting to fast changing radio link conditions and allows exploitation of multiuser diversity.
- The use of scheduled and diversity resource allocation in the frequency domain allows optimisation for various speeds, i.e., the diversity resource allocation increases frequency diversity gain at high speeds, whereas the scheduled resource allocation increases multiuser diversity gain at low speeds.
- The RLC and MAC (HARQ) status can be inherited at the target cell when the handover is intra-eNB.
- Forwarding of the data buffered in the source eNB to the target eNB prevents packet loss at handovers.
- The measurements for neighbour cells are performed without compressed mode, hence without wasting radio resources. The relevant measurements for neighbour cells that operate on a different carrier frequency from the currently served frequency, are performed during transmission/reception gaps provided by DTX/DRX, or by the packet scheduler.

## 13.6.2 Assessment on U-plane interruption time during handover

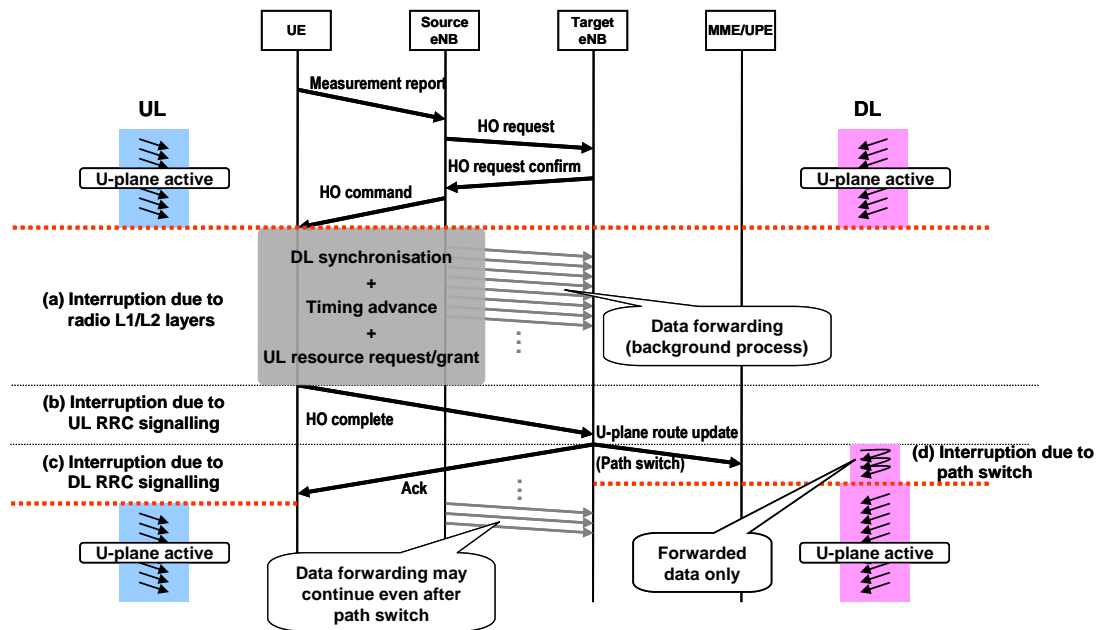

**Figure 13.3: U-Plane interruption involved in the intra-MME/UPE HO procedure in E-UTRAN**

The generic handover procedure assumed in E-UTRAN is shown in Figure 13.3, with associated delays encountered in the procedure. In the figure four constituents for the U-plane interruption are identified, i.e., (a) radio layer process, (b) UL RRC signalling, (c) DL RRC signalling, and (d) path switch. Each component is elaborated below.

- Radio layer process (a)

This is the delay between HO command to UL resource allocation, hence consisting of these elements:

- 1) Frequency synchronization: The time taken for frequency synchronisation depends whether the target cell is operating on the same carrier frequency as the currently served frequency or not. However, this should be very small because the UE has already identified and measured the target cell. Thus, the UE should have somewhat recent frequency synchronization, and the delay caused by this element is then negligible.
- 2) DL synchronization: It is thought that baseband and RF alignments may take some time. Although concrete evaluation was not performed, it was assumed that UE has acquired DL synchronisation to the target cell in conjunction with previous measurement and can relate the target cell DL timing to the source cell DL timing with an offset. Hence, the delay caused by this element should be less than 1 ms.
- 3) UL resource request and timing advance acquisition: This delay depends on the procedure applied:
  - i) RACH procedure: Should the RACH procedure be applied, the RACH allocation in the cell would dictate how long the UE has to wait before getting the first opportunity to send a RACH message and the possible need for resending. This is a fallback option for cases where non-contention based access (option ii) below) fails or is not possible.
  - ii) Dedicated RACH preamble procedure: Should the RACH procedure be applied, the RACH allocation in the cell would dictate how long the UE has to wait before getting the first opportunity to send a RACH message and the possible need for resending due to e.g. power ramping.

Some details as to the timing of the RA response remain to be settled. Reasonably accurate estimates of the delay for UL resource request and timing advance acquisition can however be provided as follow. For method i (worst case), if no retransmission is needed, the delay consists of (1) waiting for an access slot for the preamble, (2) transmission of the RA preamble, and (3) waiting for the decoding of the RA response which contains timing advance information and UL resource allocation for the HO complete message. The mean time of (1) could be 2.5 ms (assuming two access slots in 10 ms). The duration of (2) depends on the deployment scenario (e.g. ISD), but a common value is 1 sub-frame, i.e. 1 ms. The delay (3) from the end of the preamble transmission to having decoded the RA response is eNB implementation dependent, but 7.5ms is considered feasible (items 3 + 4 in C-plane latency assessment). These numbers result in a mean delay of



11 ms from the moment that the UE has synchronized to the downlink to the moment that an UL grant has been received. . A retransmission of the preamble adds to the delay at least one RTT or the access slot separation, whichever is longer. A random back-off system may also be employed, which implies that the mean delay for a retransmission is larger than the access slot separation. Various proposals for how the initial random waiting time can be reduced or avoided have been made, but are not considered in this analysis.

NOTE: If SFN would be required, it can be provided either in the HO command or by UE reading it from broadcasted System Information.

- RRC signalling (b), (c)

The detailed relation between RRC signalling and pausing/resuming of the U-plane is yet to be concluded.

For contention based access (method i), this evaluation assumes that resuming of the U-plane is triggered by RRC signalling, i.e., the HO complete triggers resuming of the DL U-plane in the target eNB, whereas the HO complete ack triggers resuming of the UL U-plane. The delay represented in this component includes the time taken to encode the RRC message at the transmitter, the time taken to transmit the message over the radio interface, and the time required to process the message at the receiver. Of the three, the time taken to transmit over the radio interface is thought to be the dominant factor. This delay can be reduced by scheduling the message at a high priority and by using a low error rate transport format. In the optimal case, this delay is expected to be approximately 5 ms, but could end up significantly longer, e.g. 20 ms, due to HARQ/ARQ. Analogous to the C-plane latency assessment, we here assume a 30% HARQ retransmission, which with a HARQ RTT of 5 ms corresponds to an average additional delay of 1.5 ms.

NOTE: For time critical messages such as RRC signalling at HO, 30% HARQ retransmission is considered a pessimistic assumption.

For non-contention based access (method ii), U-plane transmissions can possibly be resumed before RRC signalling is completed since the UE and its arrival is uniquely identified to the network by the preamble itself and successful access is acknowledged to the UE by the RA response. Hence, for non-contention based access, UP delay due to RRC signalling can be avoided if there is no need for eNB to receive HO COMPLETE before continuing U-plane transmission.

- Forwarding delay at path switch (d)

Packets sent to the source eNB just before the switching in the GW experience additional transport delay to the target-eNB because they are routed via the source eNB. However this delay does not generally result in an increase of handover interruption time if there is other data available to transmit. Worst case is when there is only 1 packet to transmit to the UE around the handover and this packet is just sent to the source-eNB when the GW decides to switch. Assuming that S1 delays to source eNB and target eNB are similar, this packet will experience an additional delay from source eNB processing and X2 transport delay. I.e., the patch switch

According to this model, the total interruption time of the U-plane in the UL is (a) + (b) + (c), whereas the interruption in the DL is (a) + (b) or (d), whichever is larger. Note that if forwarded packets are available in the target eNB before path switch, the total interruption time in the DL would be (a) + (b). The forwarding can continue even after the path switch, depending on the amount of data that had to be forwarded and the transmission rate over the inter-eNB interface. However, what is essential is the delay for the first forwarded packet to arrive at the target eNB, as the target eNB can then resume transmission as soon as the radio layer is ready, receiving the HO complete. It is generally assumed that the forwarding delay (of the first packet) is smaller than the radio layer delay (a) + (b).

**Table 13.5: U-Plane interruption components and estimates**

	Component	Cause	Estimate [ms] (contention-based)	Estimate [ms] (contention-free)
(a)	Radio layer process	- DL synchronization time, including e.g., baseband and RF switching time - UL resource request and timing advance acquisition - UL resource granting	12 ± 2.5	12 ± 2.5
(b)	UL RRC signaling	- RRC message encoding at the transmitter - RRC transmission over the radio - RRC processing time at the receiver	6.5	0
(c)	DL RRC signaling	- RRC message encoding at the transmitter - RRC transmission over the radio - RRC processing time at the receiver	6.5	0
(d)	Forwarding delay	- Source eNB processing - Packet transmission over the X2 interface	5	5

Table 13.5 shows the estimated mean value for each delay component assuming an FDD frame structure. The total average interruption time are estimated as below:

Contention-based access:

- UL interruption time = 25 ms
- DL interruption time = 18.5 ms.

Contention-free access:

- UL interruption time = 12 ms
- DL interruption time = 12 ms.

Note that these estimates may vary depending on the detailed procedures that are yet to be decided. Depending on how U-plane data forwarding is done between the source and target eNBs, the U-plane interruption time seen by the application layer may be increased due to possible duplicate transmissions of the forwarded data from the target eNB. However, in a typical case the U-plane interruption time is unlikely to exceed 100 ms. On the optimistic end, interruption times below as 12 ms are possible.

The time spent between the instance when the UE decides to transmit the measurement report and the UE receives the HO command does not contribute to the U-plane interruption. However, this delay is also expected to be kept within a bearable limit in order to avoid radio link loss between the UE and eNB, and to avoid impact on capacity.

### 13.6.3 Means to minimise packet loss during handover

As a means to minimise packet loss during handover, packet forwarding from the source eNB to the target eNB is supported using the X2 interface. When the handover does not incur change of the serving eNB, the RLC and MAC status can be inherited after the handover. If the handover involves change of the serving eNB, packets that are buffered in the source eNB are forwarded to the target eNB via the X2 interface. Hence, packet loss due to handover can be avoided. The forwarding may take place in a service dependent and implementation specific manner [ 6].

## 13.7 Coverage

The requirements on coverage as fulfilling requirements on user throughput, spectrum efficiency and mobility cases is defined in [4]. It is also defined in [4] that LTE operation should not be precluded even in very large cells (up to 100 km).

### System performance at larger cell size

The simulation cases defined in [2] covers cell ISD up to 1732 m. The fulfilment of the spectral efficiency and user throughput targets are discussed in Clause 13.5 and 13.4 respectively. This discussion is based on a number of diverse evaluation results submitted by a number of companies. A sub-set of these evaluation results also include evaluation for larger cell size up to an inter-site distance of 7500 m and a cell radius of 5000 m. These evaluations indicates that the

relative gains in LTE system performance vs. the baseline configuration defined on TR25.912, for this larger cell ranges, are in the same order as or only somewhat lower than the corresponding gains for the smaller cell ranges (1732 m).

### **Operation in very large cell sizes**

TR25.913 [2] specifies that LTE operation should be possible with cell sizes up to 100 km. It should be noted that [2] explicitly points out that high performance is not expected in such extreme cases.

One function that may limit the cell size is the random-access procedure. However, the support for very large cell size has been taken into account as part of the random-access procedure with the support of an adjustable random-access-burst length, see [2] clause 9.1.2.1.1.1

In case of TDD mode of operation, an additional critical aspect is the timing advance at the transmitter side, in order to time-align reception/transmission at the corresponding receiver side. This is enabled by the possibility for a variable number of idle symbols at the downlink/uplink switching point, see [2] clause 6.2.1. In case of very large cells, a larger number of idle symbols may be needed which may lead to a large efficiency loss in case of frequent downlink/uplink switching points, e.g. every sub-frame. However, in very-large-cell scenarios, very low round-trip time is of less importance and this less frequent downlink/uplink switching points can be applied, implying less overhead due to idle symbols. Thus, at least in this respect, also LTE TDD supports very large cell sizes.

## **13.8 Support for point to multipoint transmission**

It was found that E-UTRA point to multipoint transmission can be specified such that the corresponding requirements outlined in [4] can be met or exceeded.

The study confirmed the feasibility of efficiently multiplexing point to point and point to multi-point transmissions over the same physical channel structure thus allowing for simultaneous support of unicast and multicast services in the UE with minimum additional receiver complexity compared to UE supporting unicast services only. Such a structure also allows for the operation of point to multipoint transmissions on a separate carrier when there is a need for higher capacity as could be the case when offering mobile TV services.

The study found that with E-UTRA it would be feasible to operate point to multipoint transmissions as a single frequency network and benefit from energy combining without experiencing inter-cell interference; this is feasible provided that the cells are synchronized within a few microseconds, that the OFDM symbol cyclic prefix duration is long enough compared to the time difference between the signals received from multiple cells; this also requires that the channel structure is such that at known time instants the exact same signal is transmitted from a cluster of neighboring cells; the UE will then receive the signals from multiple cells as if they were transmitted from a single cell; the interference contribution therefore only results from thermal noise and interference from cells not in the multicast cluster or cells which timing is significantly outside of the cyclic prefix. This mode of operation is often referred to as single frequency network (SFN) and is used in state of the art digital broadcast systems. E-UTRA would still allow point to multipoint transmission within a cluster of asynchronous cells. Four cases are identified depending on the network synchronization and content transmission:

- Transmission with synchronous cells
  - Cell common point to multipoint transmission
    - E-UTRA provides significant improvements over Rel-6 MBMS (see Table 13.8-1)
  - Cell specific point to multipoint transmission
    - This scenario has not been fully evaluated but no significant gain is expected over Rel-6 MBMS.
- Transmission with asynchronous cells
  - Cell common point to multipoint transmission
    - E-UTRA is expected to perform worse than Rel-6 MBMS with combining of multiple cells. This assumes that for E-UTRA the UE would not support simultaneous data reception from multiple asynchronous cells.
  - Cell specific point to multipoint transmission

- This scenario has not been fully evaluated but no significant gain is expected over Rel-6 MBMS.

### 13.8.1 Initial performance evaluation

Table 13.6 provides a summary of the expected spectral efficiency of synchronized multi-cell point to multi-point transmission (i.e. SFN operation). The actual efficiency is directly related to the C/I at the edge of the cell and therefore highly sensitive to the maximum cell transmit power, the propagation loss (site distance, frequency band) and the cyclic prefix duration. The corresponding E-UTRA requirements have to be clarified in order to proceed with the selection of the proper cyclic prefix duration for point to multipoint transmission.

**Table 13.6: Spectral efficiency of SFN multicast for E-UTRA**

Case	Band (MHz)	Site to site distance (m)	Speed (kph)	SFN Multicast 1% BLER, 95% coverage (Mbps)
1	2000	500	3	> 5.5 (1.1 b/s/Hz)
2	2000	500	30	> 5.5 (1.1 b/s/Hz)
3	2000	1732	3	< 2.5 (0.5 b/s/Hz)
4	900	1000	3	> 5.5 (1.1 b/s/Hz)
Note:	5 MHz allocation, all cell resource assigned to multicast services, reference signal overhead is accounted for, any other control channel overhead is not accounted for.			

Additional details can be found in [5] and in clauses 7.1.1.6 and 8.1.3 of [2].

### 13.8.2 MBSFN performance evaluation

According to evaluation metric and assumption in [10], multiple evaluations that directly evaluate the uplink system performance of the LTE concept vs. the baseline configuration have been carried out. Efforts have been made to use realistic physical and link layer model. Further, fairness and coverage aspects are controlled through not only measuring average performance, but also cell-edge performance. The evaluations have been carried out by different sources/companies and for different scenarios. For both the baseline UTRA and E-UTRA results, the spectrum efficiency figures match well between companies. Summaries of the results for simulation cases 1 - 4 are presented in Table 13.7. The figures for each system concept and metric have been obtained by averaging the results presented in the individual input papers.

**Table 13.7. Summary of MBSFN performance**

Deployment	Spectrum Efficiency [bps/Hz]	Inter-site Distance @ 1bps/Hz [m]
Case 1	3.13	1619
Case 2	3.02	2310
Case 3	0.99	1619
Case 4	3.18	4375

## 13.9 Network synchronisation

The E-UTRAN design principle has been the use of an asynchronous network in case of FDD operation, i.e. in general case, tight inter-cell synchronisation is not required to provide good system performance and synchronisation is not assumed in any basic procedures like cell search, though some of the proposed methods for inter-cell interference mitigation assume synchronisation.

However, for the special case of providing multi-cell MBMS/Broadcast service there is a clear gain with tight inter-cell synchronization as this allows for an efficient and low-complexity combining of multiple cells. In the case of allocation of a separate carrier for MBMS, fewer sites can be used for MBMS and only those sites that are part of MBMS SFN need to be synchronised.

Furthermore, in case of TDD mode of operation, the network is expected to be deployed with tight inter-cell synchronization, similar to the UTRAN TDD mode of operation in order to avoid UE to UE (and eNB to eNB) interference. In this case the timing requirements might not be as tight as with the MBMS multi-cell reception, with the details depending on solutions derived.

In the uplink direction timing advance is assumed to be used, thus effectively synchronising the signals received from the terminals inside one cell as observed at the eNB. This allows to make use of a TDMA/FDMA component in uplink for resource division (without excessive "guard intervals" between different transmissions). The exact requirements for this synchronisation would be related to the physical layer parameterisation, mainly the duration of the cyclic prefix in the uplink direction.

The synchronisation methods for consideration are external timing sources like, e.g. satellite based timing source (GNSS) or then one could consider various methods, especially with TDD, of "self synchronisation" similar to the methods that have been discussed in 3GPP during UTRAN TDD development. Synchronisation techniques could also use the observation of neighbour cell signals by UEs. More studies are required for the assessment of synchronisation techniques.

The handover in E-UTRAN is a hard handover and has not been identified to be causing any additional requirements to the timing synchronisation between sites. Frequency synchronisation is helpful though to avoid drifting of relative timings and ease neighbour cell acquisition. This does however not necessarily require any explicit synchronisation but is implicitly provided by a good eNB frequency stability as already used e.g. in GSM or UMTS.

## 13.10 Co-existence and inter-working with 3GPP RAT

The U-plane interruption time is a part of the U-plane transient period, which is the time between the reception of the HO command in UE and the U-plane route update. The HO preparation period does not contribute to the U-plane interruption time.

Based on the analysis of the U-plane transient period, the total interruption time is expected to be lower than the requirement for inter-RAT handover, even in the case of inter-RAT HO from LTE to 2G/3G. The data forwarding time is expected not to affect the total DL interruption time.

Note : See clause 6.18.1 in [6] for detailed analysis.

## 13.11 General requirements

### 13.11.1 Cost related requirements

Following cost-related requirements have been identified in clause 12.1 of [4]. For each requirement it is shortly discussed how it is fulfilled by the LTE architecture.

- a) Backhaul communication protocols should be optimized.

The RNL communication was designed to get along with minimum number of communication steps for call setup and mobility. S1 and X2 interface are designed to operate and to be configured in a uniform way.

- b) The E-UTRAN architecture should reduce the cost of future network deployment whilst enabling the usage of existing site locations.

It is expected that the reduction of the number of nodes and interfaces contributes to this overall goal.

- c) All the interfaces specified shall be open for multi-vendor equipment interoperability.

Two interfaces, S1 and X2 are identified and will be standardized. There are no major problems regarding multi-vendor interoperability identified during the study item phase.

- d) UE complexity and power consumption shall be minimized/optimized. Complicated UTRAN architecture and unnecessary interfaces should be avoided.

Regarding the UE complexity requirement, see chapter 12.3. Regarding UTRAN architecture and interface, see chapter 9.8.

- e) More efficient and easy to use OAM&P.

This specific aspect needs to be covered when specifying stage 3.

### 13.11.2 Service related requirements

Following service-related requirements have been identified in clause 12.2 of [4]. It can be seen that many features related to these requirements are captured as the system concepts.

The E-UTRA should efficiently support various types of service. These must include currently available services like web-browsing, FTP, video-streaming or VoIP, and more advanced services (e.g. real-time video or push-to-x) in the PS-domain.

VoIP should be supported with at least as good radio, backhaul efficiency and latency as voice traffic over the UMTS CS networks.

Lossless HO with the forwarding technique can be applied and this can be useful for data communications. Header compression is supported as well as Release 6 and this can be useful for efficient support of low rate services, e.g. VoIP. U-plane latency is evaluated and evaluation results show that Evolved UTRAN and UTRAN can support real-time services.

High-level QoS signalling concept is studied and concluded in clause 9.6.

Support of voice traffic over the UMTS CS networks is studying in the SAE Work Item.

## 13.12 VoIP performance evaluation

According to evaluation metric and assumption in [10], multiple evaluations that directly evaluate the uplink system performance of the LTE concept vs. the baseline configuration have been carried out. Efforts have been made to use realistic physical and link layer model. Further, fairness and coverage aspects are controlled through not only measuring average performance, but also cell-edge performance. The evaluations have been carried out by different sources/companies and for different scenarios. For both the baseline UTRA and E-UTRA results, the spectrum efficiency figures match well between companies. Summaries of the results for simulation cases 1 - 3 are presented in Table 13.8. The figures for each system concept and metric have been obtained by averaging the results presented in the individual input papers.

**Table 13.8: Summary of UL and DL VoIP Capacity**

Deployment Scenario	Average VoIP Capacity (users/sector)	
	DL	UL
Case1	317	241
Case2	293	-
Case3	289	123

---

## 14 Conclusions and Recommendations

### 14.1 Conclusions

During the study of Evolved UTRA and UTRAN, many proposals on physical and higher layer radio protocols, NW architecture, RF related issues, complexity, etc were treated and studied System concepts which can meet the requirements in [1] were described based on agreed key solutions captured in this TR comprising.:

- OFDMA and SC-FDMA for downlink and uplink radio access schemes, respectively
- Support for time and frequency domain scheduling

- Simple channel structure for point to point and point to multipoint transmission
- Simple RRC state model (idle and connected)
- Reduced number of transport channels (no need for dedicated channels)
- Simplified MAC solutions ( # of MAC entities, common solution for DRX and DTX cases). Scheduling, ARQ and HARQ provided by RLC and MAC sublayers terminated in UE and eNB
- Header compression and ciphering provided by PDCP sublayer terminated in UE and aGW
- No compressed mode: transmission/reception gaps for measurement provided by scheduling
- A cell transmits one set of common channel information in a bandwidth equal than or less than the UE minimum bandwidth capability
- Simplified E-UTRAN architecture (only one type of nodes: eNB)
- Hard handover with downlink data forwarding on SDU level
- Distributed NW architecture, i.e. RRC and outer ARQ in the eNB
- NAS, terminated in UE and aGW, provides idle mode mobility handling
- NAS-related UE identities similar to 2G or 3G (IMSI/IMEI, TMSI for MME)
- Resource aggregation is only considered for broadcast-type services.

The system concepts were evaluated against the targets or requirements defined in [4]. The evaluation -results shown in this TR demonstrate that the system concepts can meet most of the requirements as follows.

- The LTE concept has the potential to fulfil both the system capacity and user throughput targets
- Evaluated uplink peak data rate is a bit smaller than the requirements, however, it is expected that the peak data rate can be increased by some optimisations, e.g. higher TTI values and/or by reducing the amount of control signaling information.
- It was confirmed that the requirements of C-plane and U-plane latency can be satisfied.
- Fulfilments without any issues are identified for requirements on deployment scenarios, spectrum flexibility, interworking, mobility, E-UTRAN architecture and RRM.
- Regarding system and device cost and complexity work needs to continue in the future. As evolved UTRA and UTRAN system will provide significantly higher data rates than Release 6 WCDMA and, as a consequence hereof, the physical layer complexity will increase accordingly compared to lower-rate systems. This complexity is not seen as evolved UTRA and UTRAN specific, but is similar to the complexity experienced in any high data rate system.

According to these evaluation results, it can be concluded that system concepts captured in this TR are feasible for evolved UTRA and UTRAN.

## 14.2 Recommendations

It is recommended to create Work Items on evolved UTRA and UTRAN. The system concept captured in this TR should be starting points for the Work Item.

## Annex A (informative): Change History

**Table A.1: Change History before approval**

Date	TSG#	TSG Doc.	Subject/Comment	Old	New
2005-12	RAN-30		Text proposals approved in RAN#30 were added in clause 7 and 9	0.0.0	0.0.2
	RAN-30		Reference [2] added	0.0.2	0.0.3
2006-3	RAN-31		Text agreed in the RAN2-RAN3-SA2 joint meeting was added in clause 9	0.0.3	0.0.4
	RAN-31		RP-060122 and RP-060171 were captured according to agreements in RAN#31	0.0.4	0.1.0
	RAN-31		A sentence in 9.3.2 was deleted according to decision in RAN#31. Note 1 in clause 9.4.2.2.1 was corrected for alignment with the RAN#31 decision on the RRC termination point.	0.1.0	0.1.1
	RAN-31		Editorial corrections. New clauses are added for system concept evaluations. Responsible WGs are clarified.	0.1.1	0.1.2
2006-5	RAN-31		R3-060512, R3-060516 and R3-060519 were captured according to agreements in RAN3#51bis.	0.1.2	0.1.3
	RAN-31		Documents which were agreed in RAN1#45, RAN2#53, RAN3#52 and RAN4#39 were captured. (documents to be approved in email discussion are not included)	0.1.3	0.1.4
	RAN-31		Documents which were agreed in RAN1#45, RAN2#53, and RAN3#52 were captured (including documents approved by email).	0.1.4	0.1.5
	RAN-31		Text proposals agreed on RAN2, RAN3 reflectors were captured. Some clean-up for e.g. removal of FFS, terminology alignment, were made. Abbreviation was added.	0.1.4	0.1.5
	RAN-31		Text proposals agreed on RAN1 reflector were captured.	0.1.5	0.1.6
2006-6	RAN-32	RP-060388	Editorial correction	0.1.6	0.1.7
	RAN-32	RP-060430	Conclusion and recommendation were included. Submission for approval	0.1.7	0.2.0
	-	-	Approved at TSG-RAN #32 and placed under Change Control	0.2.0	7.0.0

**Table A.2: Change History after approval**

Change history							
Date	TSG #	TSG Doc.	CR	Rev	Subject/Comment	Old	New
09/2006	RP-33	RP-060515	0001		Bearer and C-plane establishment	7.0.0	7.1.0
	RP-33	RP-060531	0002		Summary of downlink enhancement techniques over reference LTE unicast	7.0.0	7.1.0
06/2007	RP-36	RP-070433	0003	1	LTE performance evaluation results	7.1.0	7.2.0
12/2008	RP-42				Upgrade to Release 8 with no technical change	7.2.0	8.0.0
09/2009	RP-45				Upgrade to Release 9 with no technical change (for LTE-Advanced reference in 36.912)	8.0.0	9.0.0
03/2011	RP-51				Upgrade to Release 10 with no technical change	9.0.0	10.0.0
09/2012	RP-57				Upgrade to Release 11 with no technical change	10.0.0	11.0.0