

# 3GPP TR 25.890 V1.0.0 (2002-05)

---

*Technical Report*

**3rd Generation Partnership Project;  
Technical Specification Group Radio Access Network;  
High Speed Downlink Packet Access:  
UE Radio Transmission and Reception  
(FDD)  
(Release 5)**

---



The present document has been developed within the 3<sup>rd</sup> Generation Partnership Project (3GPP™) and may be further elaborated for the purposes of 3GPP.

The present document has not been subject to any approval process by the 3GPP Organizational Partners and shall not be implemented. This Specification is provided for future development work within 3GPP only. The Organizational Partners accept no liability for any use of this Specification. Specifications and reports for implementation of the 3GPP™ system should be obtained via the 3GPP Organizational Partners' Publications Offices.

---

Keywords

---

UMTS, radio, packet mode

**3GPP**

Postal address

---

3GPP support office address

---

650 Route des Lucioles - Sophia Antipolis  
Valbonne - FRANCE  
Tel.: +33 4 92 94 42 00 Fax: +33 4 93 65 47 16

Internet

---

<http://www.3gpp.org>

---

**Copyright Notification**

No part may be reproduced except as authorized by written permission.  
The copyright and the foregoing restriction extend to reproduction in all media.

© 2001, 3GPP Organizational Partners (ARIB, CWTS, ETSI, T1, TTA, TTC).  
All rights reserved.

# 1. Contents

2.	Foreword.....	4
3.	Scope .....	4
4.	References.....	4
5.	Definitions and Abbreviations .....	4
6.	Background and Introduction .....	5
7.	Performance Assessment – Fixed Reference Channels .....	6
7.1.	General.....	6
7.2.	Test Configuration .....	6
7.2.1.	Redundancy Version Selection .....	7
8.	Performance Assessment – Variable Reference Channels .....	9
8.1.	General.....	9
8.2.	Test Configuration .....	9
9.	Simulation Results .....	10
9.1.	Results – Fixed Reference Channels .....	10
9.2.	Results – Variable Reference Channels .....	10
10.	Annex A – Simulation Assumptions .....	11
10.1.	Downlink Physical Channels Present.....	11
10.2.	OCNS Definition .....	11
10.3.	Receiver Architectures .....	11
10.4.	Simulation Parameter Summary .....	12
11.	Annex B – Reference Channel Definition .....	13
11.1.	Fixed Reference Channel Definition .....	13
11.1.1.	Fixed Reference Channel Set 1 .....	13
11.1.2.	Fixed Reference Channel Set 2 .....	14
11.1.3.	Fixed Reference Channel Set 3 .....	15
11.1.4.	Fixed Reference Channel Set 4 .....	15
11.2.	Variable Reference Channel Definition.....	15
11.2.1.	MCC Definition .....	15
12.	Annex C – Propagation Channels .....	16
12.1.	Overview .....	16
12.2.	ITU Channel Models.....	16
12.2.1.	Pedestrian A Channel.....	16
12.2.2.	Pedestrian B Channel.....	16
12.2.3.	Vehicular-A Channel .....	16
13.	Annex D – Performance Specification .....	18
13.1.	Fixed Reference Channels .....	18
13.2.	Variable Reference Channels .....	21
14.	Annex E (Informative) – HSDPA Feature Requirements.....	23
15.	Annex F – RAN4 Related Contributions .....	24
16.	Annex G – History.....	25

---

## 2. Foreword

This Technical Report has been produced by the 3<sup>rd</sup> Generation Partnership Project (3GPP).

The contents of the present document are subject to continuing work within the TSG and may change following formal TSG approval. Should the TSG modify the contents of the present document, it will be re-released by the TSG with an identifying change of release date and an increase in version number as follows:

Version x.y.z

where:

- x the first digit:
  - 1 presented to TSG for information;
  - 2 presented to TSG for approval;
  - 3 or greater indicates TSG approved document under change control.
- y the second digit is incremented for all changes of substance, i.e. technical enhancements, corrections, updates, etc.
- z the third digit is incremented when editorial only changes have been incorporated in the document.

---

## 3. Scope

The purpose of this document is to capture the RAN4 discussions, simulation assumptions and reference channel definitions concerning transmission and reception of FDD HSDPA-related signals by the User Equipment (UE).

---

## 4. References

The following documents contain provisions which, through reference in this text, constitute provisions of the present document.

- References are either specific (identified by date of publication, edition number, version number, etc.) or non-specific.
- For a specific reference, subsequent revisions do not apply.
- For a non-specific reference, the latest version applies. In the case of a reference to a 3GPP document (including a GSM document), a non-specific reference implicitly refers to the latest version of that document *in the same Release as the present document*.

- [1] 3GPP TR 25.858 High Speed Downlink Packet Access – Physical Layer Aspects (Release 5)
- [2] 3GPP TS 25.308 High Speed Downlink Packet Access RAN2 Stage2 Description
- [3] TR 101 112 V3.2.0 (1998-04), “Selection procedures for the choice of radio transmission technologies of the UMTS”, (UMTS 30.03 version 3.2.0)

---

## 5. Definitions and Abbreviations

AMC – Adaptive Modulation Controller

H-ARQ – Hybrid Automatic Repeat Request

HS-DPCCH – High Speed Dedicated Physical Control Channel

HS-DSCH – High Speed Downlink Shared Channel

HS-PDSCH – High Speed Physical Downlink Shared Channel

HS-SCCH – High Speed Shared Control Channel

IR – Incremental Redundancy

OCNS – Orthogonal Channel Noise Simulator

RV – Redundancy Version

UE – User Equipment

---

## 6. Background and Introduction

At the RAN#11 Plenary Meeting a Work Item was approved concerning the definition of the High Speed Downlink Packet Access (HSDPA) feature for UTRA Release 5. HSDPA-related modifications to UTRA physical layer specifications are now in preparation, covering issues such as adaptive modulation and Hybrid ARQ (H-ARQ).

This document records RAN4's analysis of receiver performance for HSDPA-capable terminals, including simulation assumptions, propagation models, reference measurement channels and performance assessment criteria and results. The document is initially intended as a reference for the generation of simulation results for HSDPA receiver performance assessment. It is also intended, however, that the tests and procedures described will – with minimum modification – ultimately be included in TS 25.101 as the basis for HSDPA receiver conformance testing.

The performance analysis of HSDPA-capable UE's receiving the HS-PDSCH physical channel is based on the measured information bit throughput  $R$  sustained using H-ARQ by the UE under test.

Two distinct classes of reference measurement channel are defined for which the throughput  $R$  is measured:

- a) **Fixed reference channel** – for this class of reference measurement channel, the per-TTI information bit payload (i.e. the information bit content covered by the 24-bit CRC on the HS-DSCH) is constant and independent of the UE measurement report. This class of reference channel is defined primarily to permit straightforward comparison of initial performance results.
- b) **Variable reference channel** – for this class of reference measurement channel, the per-TTI information bit payload is controlled by the most recently received UE measurement report. The mapping between the UE measurement report and the information bit payload is controlled by the Adaptive Modulation Control (AMC) function embedded in the Node-B test emulator.

The generation of DL signals as received at the UE antenna connector needs to be revised for future work in order to realistically model features of R99 DL channels that are not covered by the current assumptions in this TR, for instance the use of transmit diversity, since these features might have an impact on performance requirements. It is RAN4's understanding that the current modelling of R99 DL channels is sufficient for investigation of RAKE receiver architectures

## 7. Performance Assessment – Fixed Reference Channels

### 7.1. General

The fixed reference channels are described in Section 11.1. The guiding principles for their definition are:

- UE capability class** – it is desirable that a UE should be assessed at the limit of its supported information bit rate capability. Accordingly, each UE is assessed using the highest information rate fixed reference channel that lies within its capability parameters. The fixed reference channels defined in Section 11.1 permit assessment of the new modulation type of 16-QAM.<sup>1</sup>
- Incremental redundancy** – since the new feature of IR (including the sub-category of Chase operation) is defined in the HS-DSCH modulation and coding chain, IR is used as the basis for fixed channel definition, and
- H-ARQ processes** – since the H-ARQ entity in the UE is required to support multiple H-ARQ processes (under a semi-static partition defined by higher-layer signalling), the fixed reference channels are defined consistent with multiple H-ARQ processes in the UE under test, where the number of H-ARQ processes are consistent with the capability class (specifically, with the inter-TTI distance capability parameter).

### 7.2. Test Configuration

The basic test apparatus configuration (and link simulation configuration) for fixed reference channels appears in Figure 1. As well as transmitting various downlink control channels (Section 10.1), the Node-B test apparatus transmits a 12.2kbps DPCH, one or more HS-SCCH's (at minimum, from the UE's perspective, the HS-SCCH set is of size greater than 1) and the HS-PDSCH. In addition, the Node-B test emulator transmits an OCNS signal required specified in Section 10.1. The UE under test transmits the complementary uplink DPCH and the HS-DPCCH (for ACK/NACK transfer in the case of the fixed reference channels).

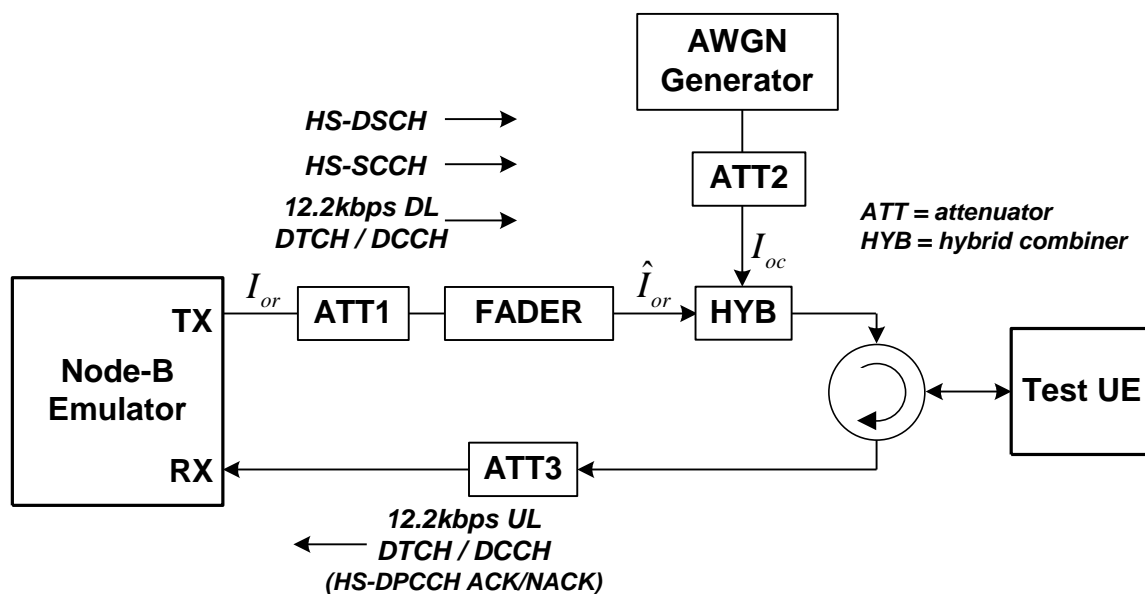

Figure 1. Test configuration – fixed reference channel.

For each of the propagation channels specified in Section 13.1, using a constant value of  $\hat{I}_{or} / I_{oc}$ , and corresponding specified downlink DPCH and HS-SCCH  $E_c / I_{or}$  values, the information bit throughput  $R$  is measured as a function of

<sup>1</sup> Currently mandatory for all HSDPA-capable UE's

HS-PDSCH  $E_c/I_{or}$ . For fixed reference channels where the UE soft channel bit resource is partitioned between multiple H-ARQ processes, the test Node-B emulator transmits using each H-ARQ process in sequence. That is, on each valid successive TTI (observing the minimum inter-TTI interval of the UE) the test Node-B emulator increments the HS-SCCH H-ARQ process identifier modulo the number of defined H-ARQ processes.

As defined in [1], up to a maximum specified number of transmissions, each H-ARQ process transmission or re-transmission comprises a redundancy version derived using the HS-DSCH encoding and rate-matching procedure. If the maximum number of transmission attempts (specified in Section 10.4) is exceeded without reception of an ACK on the error-free uplink HS-DPCCH, the entire content of the information bit payload is assumed to have been lost. On the next transmission using the H-ARQ process for which the maximum number of transmission attempts has expired, the test Node-B emulator generates a new TTI information bit payload, and increments the HS-SCCH new data indicator field.

During the test, the ratio  $\hat{I}_{or}/I_{oc}$  of the HS-PDSCH serving cell received power spectral density  $\hat{I}_{or}$  to interference spectral density  $I_{oc}$  is maintained at a constant level, at the value specified in the Section 13.1. The fraction of the Node-B radiated power allocated to the HS-PDSCH – expressed as the ratio  $E_c/I_{or}$  of energy per chip  $E_c$  assigned to the HS-PDSCH (in fact, the sum of the energy per chip of all the length-16 multicode comprising the HS-PDSCH) divided by the transmitted power spectral density  $I_{or}$  – is varied over the range specified in Section 13.1.

For each value of HS-PDSCH  $E_c/I_{or}$ , the measured information bit throughput  $R$  is defined as the sum (in kilobits) of the information bit payloads (excluding the 24-bit HS-DSCH CRC) successfully received during the test interval, divided by the duration of the test interval (in seconds). The resulting throughput is expressed in units of kilobits/s (kbps) as a function of HS-PDSCH  $E_c/I_{or}$ .

The interference process represented by  $I_{oc}$  in Figure 1 is currently assumed to be temporally uncorrelated (i.e. spectrally white).

#### 7.2.1. Redundancy Version Selection

For each successive RV transmission on a specific H-ARQ process, the Node-B test emulator transmits a set sequence of RV's [12].

The  $k$ -th transmitted RV (where  $k = 0, 1, \dots$ ) is expressed in terms of the RV selection parameters  $X_{rv}$ s and  $r$  of the HS-DSCH coding and rate-matching procedure [1] according to modulation as presented in the Tables A and B below as follows (“mod” represents modulo function):

k mod 4	$X_{rv}$
	QPSK
0	0
1	2
2	5
3	6

**Table A : RV selection for QPSK**

k mod 4	$X_{rv}$
	16QAM
0	6
1	2

2	1
3	5

**Table B: RV selection for 16-QAM**



## 8. Performance Assessment – Variable Reference Channels

### 8.1. General

The variable reference channels are described in Section 11.2. The guiding principles for their definition are:

- Variable payload** – the per-TTI information bit payload is determined by the AMC function located in the Node-B test emulator. The AMC accepts as input the uplink HS-DPCCH UE measurement report as described in Section 11.2.1
- Number of HS-PDSCH codes** – the AMC is defined in such a way as to permit a variable number of HS-PDSCH multicodes to be transmitted, ideally varying from single code transmission at low HS-PDSCH  $E_c / I_{or}$  to the maximum number of codes supported by the HS-PDSCH code handling capability parameter of the UE under test.

### 8.2. Test Configuration

The basic test apparatus configuration (and link simulation configuration) for variable reference channels appears in Figure 2. As well as transmitting various downlink control channels (Section 10.1), the Node-B test apparatus transmits a 12.2kbps DPCH, one or more HS-SCCH's (at minimum, from the UE's perspective, the HS-SCCH set is of size greater than 1) and the HS-PDSCH. In addition, the Node-B test emulator transmits an OCNS signal required specified in Section 10.1. The UE under test transmits the complementary uplink DPCH and the HS-DPCCH (for ACK/NACK and UE measurement report transfer).

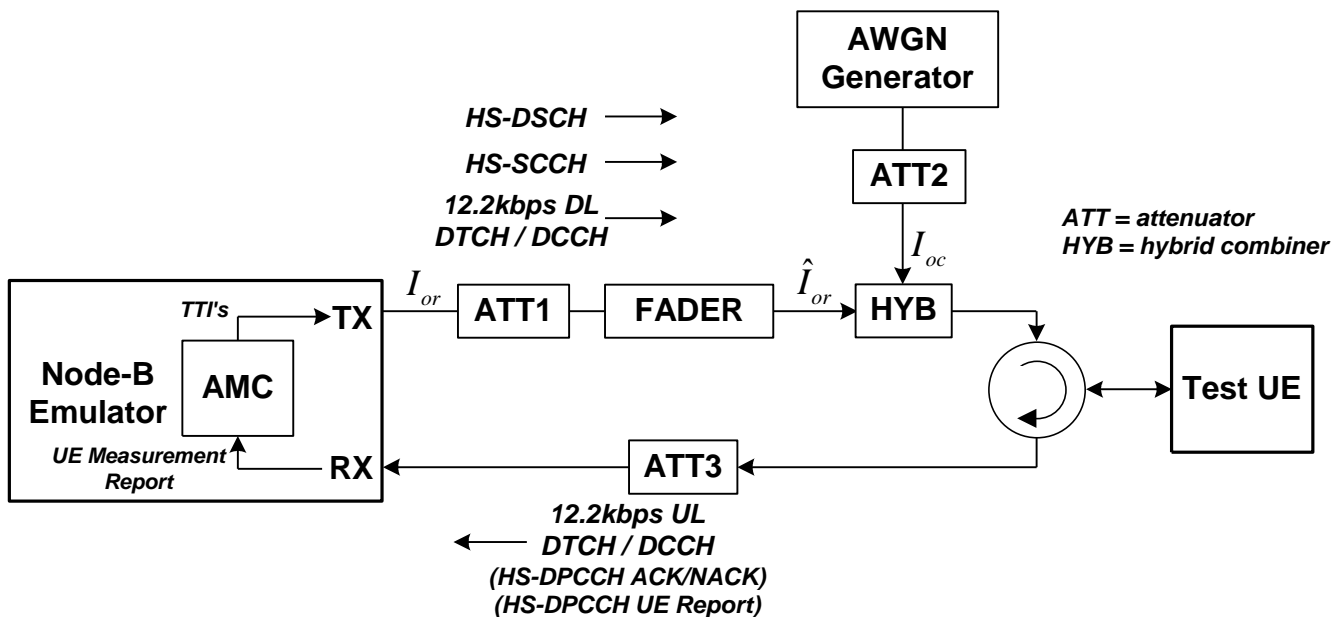

Figure 2. Test configuration – variable reference channel.

For the variable reference channel, the definition of the measured information bit throughput, the maximum number of transmissions per H-ARQ process, and the variation of  $\hat{I}_{or} / I_{oc}$  and HS-PDSCH  $E_c / I_{or}$  during the test are identical to the procedure for fixed reference channels. The test procedure for the variable reference channels deviates, however, in the computation of the information bit payload, the instantaneous coding rate and the number of HS-PDSCH codes to be transmitted.

In the case of variable reference channels, the transmission information bit payload is determined at the start of each H-ARQ transmission cycle by the AMC function located in the Node-B test emulator. The input to the AMC function is the UE measurement report received on the HS-DPCCH. Based on the UE measurement report, the AMC function also determines the instantaneous coding rate and the number of HS-PDSCH codes to transmit.

## 9. Simulation Results

This section contains a summary of the simulation results offered by each company.

### 9.1. Results – Fixed Reference Channels

Results were presented for the tests suggested in the previous version of the TR25.890 v0.0.1 [15] in [16], [17], [18], [19], [20] and [22]. These results are summarized in the following table [21].

	$E_c/I_{or}$ (dB)	Throughput (kbps)				
		Ericsson [19]	Motorola [16]	Nokia [12]	NTT DoCoMo [18]	Qualcomm [20] and [22]
Test a (AWGN)	-15	[394] <sup>5</sup>	350	-	[394]	394
	-10	[788]	788	[788]	[788]	788
Test 1 (PB3)	-10	-	0	[0]	[1.67]	9.5
	-4	-	300	[290]	[300]	280
	-2	-	400	-	[450]	400
Test 2 (VA30)	-10	-	0	[0]	[0]	0
	-4	-	330	[300]	[250]	314
	-2	-	440	-	[400]	420
Test 3 (VA120)	-10	-	0	[0]	[0]	0
	-4	-	310	[280]	[225]	318
	-2	-	400	-	[350]	375

**Table 1 Results for tests proposed in [15]**

Future results will be included in this section.

### 9.2. Results – Variable Reference Channels

Results will be presented for variable reference channels.

<sup>5</sup> Results in brackets have been estimated from graphs and have to be confirmed from the respective companies

## 10. Annex A – Simulation Assumptions

### 10.1. Downlink Physical Channels Present

The following downlink physical channels are present during testing.

Physical Channel	Parameter	Value	Note
P-CPICH	P-CPICH_Ec/Ior	-10dB	
P-CCPCH	P-CCPCH_Ec/Ior	-12dB	As specified in TS 25.101 Annex C – mean power level is shared with SCH.
SCH	SCH_Ec/Ior	-12dB	As specified in TS 25.101 Annex C – mean power level is shared with P-CCPCH – SCH includes P- and S-SCH, with power split between both.
PICH	PICH_Ec/Ior	-15dB	As specified in TS 25.101 Annex C.
DPCH	DPCH_Ec/Ior	<b>Test-specific</b>	Specified in Section 13.
HS-SCCH_1	HS-SCCH_Ec/Ior	<b>Test-specific</b>	Specifies fraction of Node-B radiated power transmitted when TTI is active (i.e. due to minimum inter-TTI interval). Specified in Section 13.
HS-SCCH_2	HS-SCCH_Ec/Ior	<b>DTX'd</b>	No signalling scheduled, or power radiated, on this HS-SCCH, but signalled to the UE as present.
HS-SCCH_3	HS-SCCH_Ec/Ior	<b>DTX'd</b>	As HS-SCCH_2.
HS-SCCH_4	HS-SCCH_Ec/Ior	<b>DTX'd</b>	As HS-SCCH_2.
HS-PDSCH	HS-PDSCH_Ec/Ior	<b>Test-specific</b>	Specified in Section 13.
OCNS		<b>Test-specific</b>	Balance of power $I_{or}$ of the Node-B is assigned to OCNS.

**Table 2 – Downlink physical channels for HSDPA receiver testing.**

### 10.2. OCNS Definition

The selected channelization codes and relative power levels for OCNS transmission during for HSDPA performance assessment are defined in Table 3 [7]. The selected codes are designed to have a single length-16 parent code. The relative power level of each code is specified in such a way that the sum of the allocated powers in Table 3 is unity.

Channelization Code at SF=128	Relative Level setting (dB)	DPCH Data
2	-6	The DPCH data for each channelization code shall be uncorrelated with each other and with any wanted signal over the period of any measurement.
3	-8	
4	-8	
5	-10	
6	-7	
7	-9	

**Table 3 – OCNS definition for HSDPA receiver testing.**

### 10.3. Receiver Architectures

As described in [13], initial simulation results will be based on the RAKE receiver architecture, and any results for other receiver architectures can also be presented.

## 10.4. Simulation Parameter Summary

Parameter	Assumption
Chip rate	3.84 Mcps
HS-DSCH fixed reference channels	Section 13.1
HS-DSCH variable reference channels	Section 13.2
HSDPA control channels present	HS-SCCH set size is 4
OCNS	Used to sum total radiated $E_c/I_{or}$ to unity (Section 10.1, 10.2)
DL DPCH reference channel	12.2 kbps
DL DPCH closed loop power control	Off
Channel estimation	The location of each ray on the channel is known <i>a-priori</i> to the receiver, but the channel tap values (i.e. the complex coefficient associated with each multipath component) are estimated by the receiver.
RX AGC	Off
HS-PDSCH Pilot-Data Ratio	Estimated
Number of samples per chip ( $P$ ) for channel synthesis	$P = 2$ – i.e. 2 samples per chip at input to receiver
SRRC pulse shaping	On
Propagation channel types	AWGN, ITU PA3, ITU PB3, ITU VA30, ITU VA120 (Section 12.2)
Channel ray mapping	Nearest $T_c / P$ -spaced delay ( $1/T_c$ is chip rate) – $P$ specified above.
Number of bits in A/D converter	Floating point
IR coding	As specified by RAN-WG1
RV sequence	Section 7.2.1
Max number of transmissions per H-ARQ process	4
Number HS-DSCH transport channels	1
Turbo decoding	MaxLogMap - 8 iterations
$I_{oc}$	-60 dBm
P-CCPCH	Random symbols transmitted – ignored by receiver
PICH	Random symbols transmitted – ignored by receiver
ACK/NACK feedback error rate	0%
UE measurement report error rate	0%

**Table 4 – Simulation parameters for HSDPA receiver testing.**

# 11. Annex B – Reference Channel Definition

## 11.1. Fixed Reference Channel Definition

### 11.1.1. Fixed Reference Channel Set1

Parameter	Unit	Value	
Peak Inf. Bit Rate	kbps	1600	2352
Nominal Avg. Inf. Bit Rate	kbps	533	784
Inter-TTI Distance	TTI's	3	3
Number of HARQ Processes	Processes	2	2
Information Bit Payload ( $N_{INF}$ )	Bits	3200	4704
Number Code Blocks	Blocks	1	1
Binary Channel Bits Per TTI	Bits	4800	7680
Total Available SML's <sup>2</sup> in UE	SML's	19200	19200
Number of SML's per HARQ Proc.	SML's	9600	9600
Inst. Coding Rate		0.67	0.62
Final Coding Rate		0.33	0.49
Number of Physical Channel Codes	Codes	5	4
Modulation		QPSK	16QAM

Table 5 Fixed Reference Channel Set 1

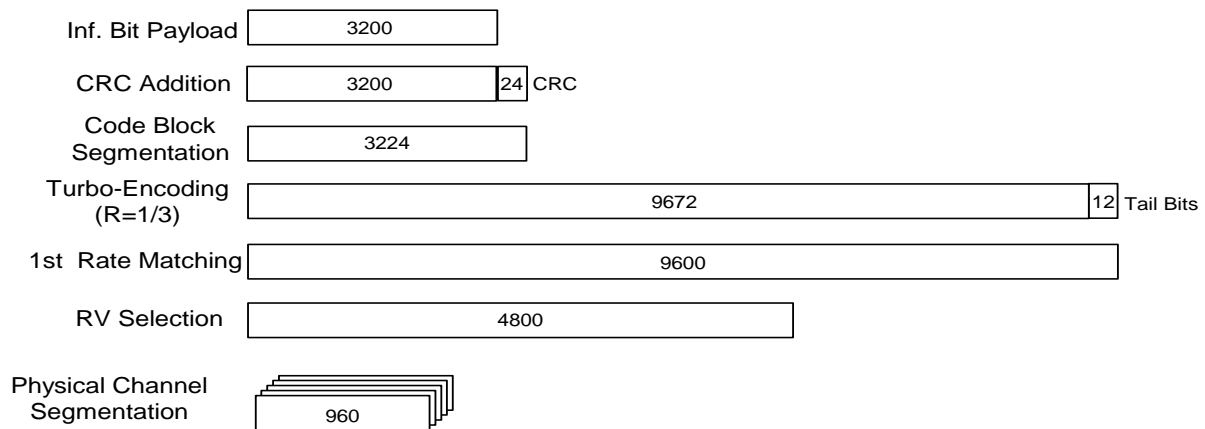

Figure 3. Coding rate for Fixed reference Channel Set 1 (QPSK)

<sup>2</sup> SML = Soft Metric Location, or storage of soft metric representation for a single uncoded bit.

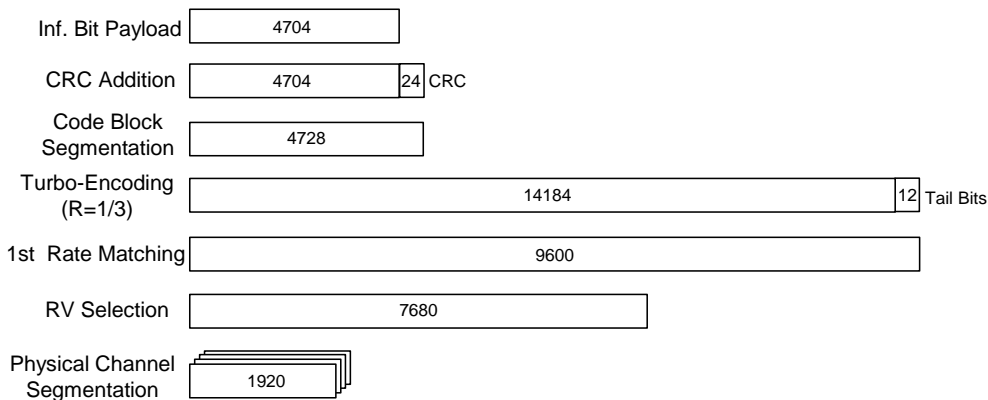

Figure 4. Coding rate for Fixed reference Channel Set 1 (16 QAM)

11.1.2. Fixed Reference Channel Set 2

Parameter	Unit	Value	
		1	2
Peak Inf. Bit Rate	kbps	1600	2352
Nominal Avg. Inf. Bit Rate	kbps	1600	2352
Inter-TTI Distance	TTI's	1	1
Number of HARQ Processes	Processes	6	6
Information Bit Payload ( $N_{INF}$ )	Bits	3200	4704
Number Code Blocks	Blocks	1	1
Binary Channel Bits Per TTI	Bits	4800	7680
Total Available SML's <sup>3</sup> in UE	SML's	57600	57600
Number of SML's per HARQ Proc.	SML's	9600	9600
Inst. Coding Rate		0.67	0.62
Final Coding Rate		0.33	0.49
Number of Physical Channel Codes	Codes	5	4
Modulation		QPSK	16QAM

Table 6 Fixed Reference Channel Set 2

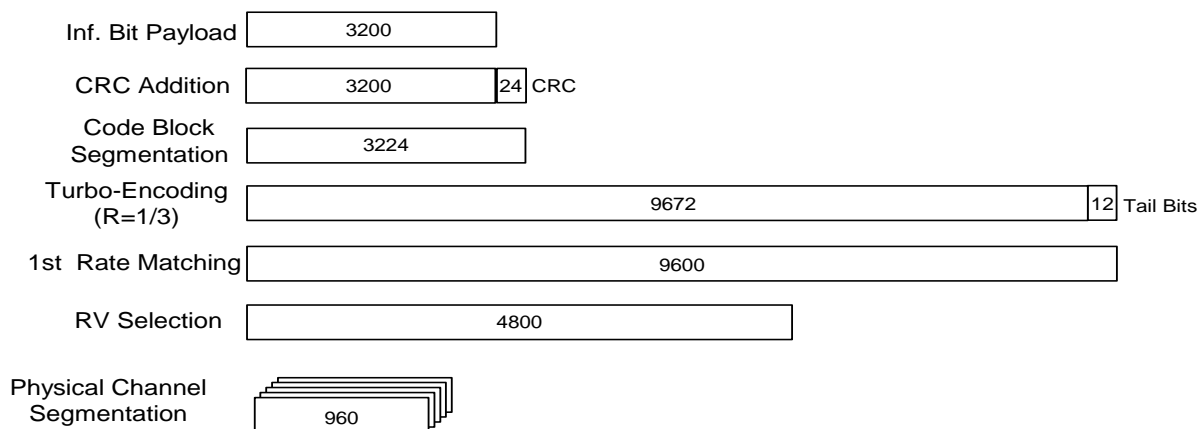
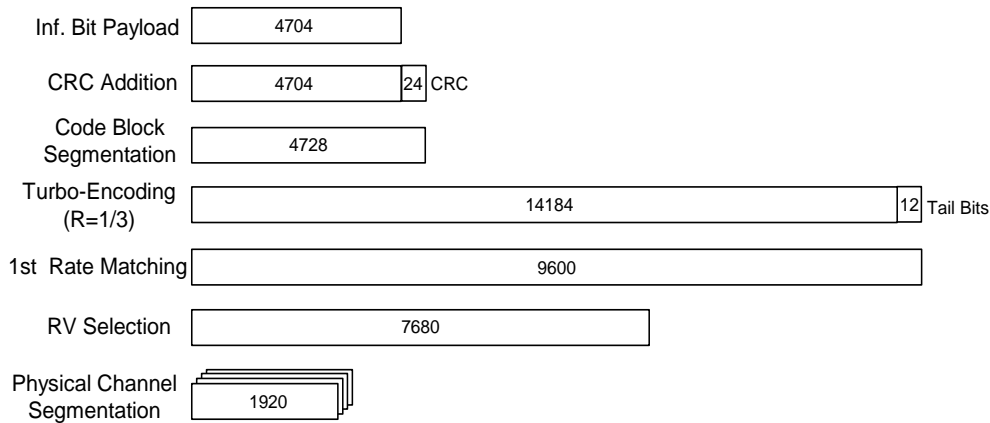

Figure 5. Coding rate for Fixed reference Channel Set 2 (QPSK)

<sup>3</sup> SML = Soft Metric Location, or storage of soft metric representation for a single uncoded bit.



**Figure 6. Coding rate for Fixed reference Channel Set 2 (16 QAM)**

### 11.1.3. Fixed Reference Channel Set 3

The detailed specification of this reference channel is TBD after completion of the RAN1 HSDPA UE capability discussion.

### 11.1.4. Fixed Reference Channel Set 4

The detailed specification of this reference channel is TBD after completion of the RAN1 HSDPA UE capability discussion.

## 11.2. Variable Reference Channel Definition

The variable reference measurement channels are defined by a) the maximum information bit payload supported by the capability UE under test and b) the most recently received UE measurement report.

### 11.2.1. MCC Definition

The MCC does not control the value of HS-PDSCH  $E_c / I_{or}$  – this is fixed according to Section 13.2. Nor does the MCC specify the H-ARQ process number – as described for fixed reference channels, this number is simply incremented in for successive TTI's.

Two proposals have been made for detailed specification of the MCC function, specifically:

- as proposed in [11], the Node-B test emulator MCC delivers the TTI information bit payload specified in the UE measurement report, where the UE measurement report explicitly reports a feasible information rate,
- as proposed in [6], the Node-B test emulator MCC computes the TTI information bit payload based on a signal-noise-ratio based UE measurement report.

The MCC function to be selected is for further study, and will be determined following clarification by RAN1 of the UE measurement report.

## 12. Annex C – Propagation Channels

### 12.1. Overview

The choice of propagation models are guided by the requirements laid down in Annex A (Informative) of [1] (reproduced in Section 14) which states that HSDPA operation should be optimised under propagation conditions and Doppler frequencies consistent with urban areas, but that high speed operation should not be precluded.

The primary Doppler frequencies at which assessment is emphasized UE velocities between 3-30km/h, but limited testing at Doppler frequencies corresponding to 120km/h is retained (see Section 13) in order to ensure system robustness at higher speeds. This selection is reflected in the simulation assumptions. (Section 13).

The ITU channel models Pedestrian-A at 3km/h (“PA3”), Pedestrian-B at 3km/h (“PB3”) and Vehicular-A at 30km/h (“VA30”) are chosen as the primary models for testing purposes. In addition, a single test based on Vehicular-A at 120km/h (“VA120”) is retained to verify receiver robustness during high speed operation. The ITU Pedestrian-B and Vehicular-A models are defined below.

An AWGN channel is used for initial simulator alignment during RAN4 discussions.

### 12.2. ITU Channel Models

The ITU channels models are specified in e.g. [3], and – for convenience – are reproduced in the following sections. For simulation purposes, the waveform offered to the receiver input is synthesised at the rate of  $P/T_c$  where  $T_c$  is the chip interval and  $P$  is an over-sampling factor (specified in Section 10). Channel taps specified in the ITU models are mapped to the nearest  $T_c/P$ -spaced sample.

#### 12.2.1. Pedestrian A Channel

The multipath intensity profile of the Pedestrian-A channel is defined as follows:

<b>Relative Delay (ns)</b>	0	110	190	410
<b>Relative Power (dB)</b>	0.0	-9.7	-19.2	-22.8

**Table 7 - ITU Pedestrian-A channel model.**

#### 12.2.2. Pedestrian B Channel

The multipath intensity profile of the Pedestrian-B channel is defined as follows:

<b>Relative Delay (ns)</b>	0	200	800	1200	2300	3700
<b>Relative Power (dB)</b>	0.0	-0.9	-4.9	-8.0	-7.8	-23.9

**Table 8 - ITU Pedestrian-B channel model.**

#### 12.2.3. Vehicular-A Channel

The multipath intensity profile of the Vehicular-A channel is defined as follows:

<b>Relative Delay (ns)</b>	0	310	710	1090	1730	2510
----------------------------	---	-----	-----	------	------	------



<b>Relative Power (dB)</b>	0.0	-1.0	-9.0	-10.0	-15.0	-20.0
--------------------------------	-----	------	------	-------	-------	-------

**Table 9 - ITU Vehicular-A channel model.**

---

## 13. Annex D – Simulation Parameters and Results

### 13.1. Fixed Reference Channels

The performance specifications for the Fixed Reference Channel Sets 1 and 2 appear in 11.1.1 and 11.1.2 respectively. Specifications for the Fixed Reference Channel Sets 3 and 4 are for further study on completion of the RAN1 UE capability discussion.

**Note 1** – Initially, for the purposes of simulation, results should be generated over the *range* of  $E_c/I_{or}$ . The range should include the interval between  $-13$  dB to  $-2$  dB with a resolution of greater than or equal 2 dB. Also  $\hat{I}_{or}/I_{oc}$  values of 0 dB, 5 dB, 10 dB and 15 dB will be used initially. During the subsequent performance assessment phase, a set of distinct values of HS-PDSCH  $E_c/I_{or}$  may be specified as the reference HS-PDSCH  $E_c/I_{or}$  values.

**Note 2** – The AWGN propagation channel is defined in order to make easier initial alignment of simulation results.

**Note 3** – Each table may be simplified in future if constant values of  $\hat{I}_{or}/I_{oc}$  are specified. The same comment applies to DPCH  $E_c/I_{or}$  and HS-SCCH  $E_c/I_{or}$ . This is for further study.

**Note 4** – RAN1 has not completed the definition of the signalling requirements for HSDPA (e.g. HS-SCCH definition). Accordingly, for in initial simulation purposes the power assigned to the DPCH and HS-SCCH channels is set to zero, and the power allocated to these channels is re-assigned to the OCNS transmission. Initial simulation results further assume error-free DPCH and HS-SCCH signalling data reception. The power allocation to the DPCH and HS-SCCH channels required to meet the signalling performance requirements is for further study.

Test Number	Propag. Channel	Test Parameters			Reference value	
		$\hat{I}_{or}/I_{oc}$ (dB)	HS-SCCH $E_c/I_{or}$ (dB)	DPCH $E_c/I_{or}$ (dB)	HS-PDSCH $E_c/I_{or}$ (dB) (Note 1)	T-put R (kbps)
a	AWGN (Note 2)	TBD	Note 4	Note 4	TBD	TBD
					TBD	TBD
1	PA3	TBD	Note 4	Note 4	TBD	TBD
					TBD	TBD
2	PB3	TBD	Note 4	Note 4	TBD	TBD
					TBD	TBD
3	VA30	TBD	Note 4	Note 4	TBD	TBD
					TBD	TBD
4	VA120	TBD	Note 4	Note 4	TBD	TBD
					TBD	TBD

Table 10 Fixed Reference Channel Set 1 – QPSK Reference Performance

Test Number	Propag. Channel	Test Parameters			Reference values	
		$\hat{I}_{or}/I_{oc}$ (dB)	HS-SCCH $E_c/I_{or}$ (dB)	DPCH $E_c/I_{or}$ (dB)	HS-PDSCH $E_c/I_{or}$ (dB) (Note 1)	T-put R (kbps)
a	AWGN (Note 2)	TBD	Note 4	Note 4	TBD	TBD
					TBD	TBD
1	PA3	TBD	Note 4	Note 4	TBD	TBD
					TBD	TBD
2	PB3	TBD	Note 4	Note 4	TBD	TBD
					TBD	TBD

3	VA30	TBD	Note 4	Note 4	TBD	TBD
					TBD	TBD
4	VA120	TBD	Note 4	Note 4	TBD	TBD
					TBD	TBD

Table 11 Fixed Reference Channel Set 1 – 16 QAM Reference Performance

Test Number	Propag. Channel	Test Parameters			Reference values	
		$\hat{I}_{or}/I_{oc}$ (dB)	HS-SCCH $E_c/I_{or}$ (dB)	DPCH $E_c/I_{or}$ (dB)	HS-PDSCH $E_c/I_{or}$ (dB) (Note 1)	T-put $R$ (kbps)
a	AWGN (Note 2)	TBD	Note 4	Note 4	TBD	TBD
					TBD	TBD
1	PA3	TBD	Note 4	Note 4	TBD	TBD
					TBD	TBD
2	PB3	TBD	Note 4	Note 4	TBD	TBD
					TBD	TBD
3	VA30	TBD	Note 4	Note 4	TBD	TBD
					TBD	TBD
4	VA120	TBD	Note 4	Note 4	TBD	TBD
					TBD	TBD

Table 12 Fixed Reference Channel Set 2 – QPSK Reference Performance

Test Number	Propag. Channel	Test Parameters			Reference values	
		$\hat{I}_{or}/I_{oc}$ (dB)	HS-SCCH $E_c/I_{or}$ (dB)	DPCH $E_c/I_{or}$ (dB)	HS-PDSCH $E_c/I_{or}$ (dB) (Note 1)	T-put $R$ (kbps)
a	AWGN (Note 2)	TBD	Note 4	Note 4	TBD	TBD
					TBD	TBD

1	PA3	TBD	Note 4	Note 4	TBD	TBD
					TBD	TBD
2	PB3	TBD	Note 4	Note 4	TBD	TBD
					TBD	TBD
3	VA30	TBD	Note 4	Note 4	TBD	TBD
					TBD	TBD
4	VA120	TBD	Note 4	Note 4	TBD	TBD
					TBD	TBD

Table 13 Fixed Reference Channel Set 2 - 16 QAM Reference Performance

### 13.2. Variable Reference Channels

The simulation assumptions for the variable reference channels follow the formulation specified for the fixed reference channel and are applicable for the capability classes corresponding to Fixed Reference Channel Sets 1 and 2. (called Variable Reference Channel 1 and 2 respectively). Specifications for capability classes corresponding to Fixed Reference Channel Sets 3 and 4 (called Variable Reference Channel 3 and 4 respectively) are for further study on completion of the RAN1 UE capability discussion.

The same notes described in Section 13.1 applicable to fixed reference channels re-apply for Fixed Reference Channel sets 1 and 2.

Note: This section will be revised after WG1 comes to a final conclusion of CQI (Channel Quality Indicator) definition.

Test Number	Propag. Channel	Test Parameters			Reference values	
		$\hat{I}_{or} / I_{oc}$ (dB)	HS-SCCH $E_c / I_{or}$ (dB)	DPCH $E_c / I_{or}$ (dB)	HS-PDSCH $E_c / I_{or}$ (dB) (Note 1)	T-put $R$ (kbps)
a	AWGN (Note 2)	TBD	Note 4	Note 4	TBD	TBD
					TBD	TBD
1	PA3	TBD	Note 4	Note 4	TBD	TBD
					TBD	TBD
2	PB3	TBD	Note 4	Note 4	TBD	TBD
					TBD	TBD
3	VA30	TBD	Note4	Note4	TBD	TBD
					TBD	TBD

Table 14 Variable Reference Channel 1 corresponding to Fixed Reference Channel Set 1 – Reference Performance

Test Number	Propag. Channel	Test Parameters			Reference values	
		$\hat{I}_{or}/I_{oc}$ (dB)	HS-SCCH $E_c/I_{or}$ (dB)	DPCH $E_c/I_{or}$ (dB)	HS-PDSCH $E_c/I_{or}$ (dB) (Note 1)	T-put $R$ (kbps)
a	AWGN (Note 2)	TBD	Note 4	Note 4	TBD	TBD
					TBD	TBD
1	PA3	TBD	Note 4	Note 4	TBD	TBD
					TBD	TBD
2	PB3	TBD	Note 4	Note 4	TBD	TBD
					TBD	TBD
3	VA30	TBD	Note4	Note4	TBD	TBD
					TBD	TBD

Table 15 Variable Reference Channel 2 corresponding to Fixed Reference Channel Set 2 – Reference Performance

---

## 14. Annex E (Informative) – HSDPA Feature Requirements

This informative annex is replicated for informational purposes from [1].

The following considerations should be taken into account in the evaluation of the different techniques proposed for HSDPA.

1. The focus shall be on the streaming, interactive and background services. It should be noted that it may not be possible to simultaneously optimise the characteristics of HSDPA for all of the above traffic classes.
2. System performance improvement shall be obtained with the concomitant reduction in delay of service.
3. Priority shall be given to urban environments and then to indoor deployments. The techniques shall not be limited to these environments however.
4. The techniques accepted shall be optimised at speeds typical of urban environments but techniques should apply at other speeds also. Full mobility shall be supported, i.e., mobility should be supported for high-speed cases also, but optimisation should be for low-speed to medium-speed scenarios.
5. Features or group of features considered should demonstrate significant incremental gain.
6. Features accepted shall provide the benefit at reasonable cost to the operators. The value added per feature should be considered in the evaluation.
7. The techniques should be compatible with advanced antenna and receiver techniques.
8. The techniques should take into account the impact on R99 networks both from a protocol and hardware perspective.
9. The choice of techniques (such as HARQ) shall take into account UE processing time and memory requirements.
10. The UE complexity shall be minimised for a given level of system performance.

An evolutionary philosophy shall be adopted as opposed to a revolutionary one in adopting new techniques and architectures.

---

## 15. Annex F – RAN4 Related Contributions

This section indicates contributions to RAN4 on HSDPA receiver performance testing.

- [4] R4-011437, Motorola, *HSDPA UE performance requirements*
- [5] R4-011452, Nokia, *Assumptions for HS-DSCH demodulation performance tests (FDD)*  
R4-020005, Motorola, UE measurement report
- [6] R4-020006, Motorola, *Adaptive Modulation and Coding for HSDPA Testing*
- [7] R4-020007, Motorola, *OCNS Definition for HSDPA*
- [8] R4-020008, Motorola, *Revised HSDPA UE performance requirements*
- [9] R4-020036, Motorola, *Simulation Results for HSDPA UE Performance Tests*
- [10] R4-020075, Nokia, *Considerations on HSDPA system scenarios*
- [11] R4-020188, Ericsson, *Proposal for simulation assumptions of HSDPA*
- [12] R4-020359, Nokia, *Comments on HSDPA testing*
- [13] R4-020516, Adhoc Group, *Simulation assumptions for HSDPA testing*
- [14] R4-020519, Liaison Statement, LS to RAN1 on HSDPA open issues
- [15] 3GPP Draft Technical Report 25.890, “High Speed Downlink Packet Access: UE Radio Transmission and Reception (FDD)”, vsn. 0.0.1 (2002-02)
- [16] R4-020615, Motorola, “HS-DSCH Simulation Results”, RAN4#22, Sophia Antipolis, France, April 2002.
- [17] R4-020589, Nokia, “HSDPA Throughput Simulation Results”, RAN4#22, Sophia Antipolis, France, April 2002.
- [18] R4-020608, NTT DoCoMo, “Simulation Results for HSDPA Performance Requirement”, RAN4#22, Sophia Antipolis, France, April 2002.
- [19] R4-020542, Ericsson, “Simulation Throughput Results for Fixed Reference HS-DSCH”, RAN4#22, Sophia Antipolis, France, April 2002.
- [20] R4-020644, Qualcomm, “Throughput Simulation Results for Fixed Reference HS-DSCH in AWGN conditions”, RAN4#22, Sophia Antipolis, France, April 2002.
- [21] R4-020649, Motorola, “Link Level Simulation Results Comparison for HSDPA”, RAN4#22, Sophia Antipolis, France, April 2002.
- [22] R4-020644, Qualcomm, “Throughput Simulation Results for Fixed Reference HS-DSCH in fading conditions”, RAN4#22, Sophia Antipolis, France, April 2002.



16.

Annex G – History

V0.0.1	13/02/02	RSB			Initial outline draft following discussions at RAN4#21 [13]		
V0.0.2	5/4/02	RSB			Revision after HSDPA adhoc at RAN4#22		
V0.0.3	30/4/02	RSB			Revision presented at RAN4#23		
V1.0.0	27/5/02	EPF			Revision presented at RAN#16		