

3GPP TR 25.879 V5.0.0 (2002-03)

Technical Report

3rd Generation Partnership Project; Technical Specification Group Radio Access Network; Separation of resource reservation and radio link activation (Release 5)



The present document has been developed within the 3rd Generation Partnership Project (3GPP™) and may be further elaborated for the purposes of 3GPP.

The present document has not been subject to any approval process by the 3GPP Organizational Partners and shall not be implemented. This Specification is provided for future development work within 3GPP only. The Organizational Partners accept no liability for any use of this Specification. Specifications and reports for implementation of the 3GPP™ system should be obtained via the 3GPP Organizational Partners' Publications Offices.

Keywords

3GPP

Postal address

3GPP support office address

650 Route des Lucioles - Sophia Antipolis
Valbonne - FRANCE
Tel.: +33 4 92 94 42 00 Fax: +33 4 93 65 47 16

Internet

<http://www.3gpp.org>

Copyright Notification

No part may be reproduced except as authorized by written permission.
The copyright and the foregoing restriction extend to reproduction in all media.

© 2002, 3GPP Organizational Partners (ARIB, CWTS, ETSI, T1, TTA, TTC).
All rights reserved.

Contents

Foreword	4
1 Scope	5
2 References.....	5
3 Definitions, symbols and abbreviations	5
3.1 Definitions.....	5
3.2 Symbols	5
3.3 Abbreviations	5
4 Introduction	6
5 Requirements.....	6
6 RAN3 Study areas.....	7
6.1 General.....	7
6.2 Avoiding potential handover problem.....	7
6.2.1 Problem	7
6.2.2 Proposed solution	7
6.3 Pre-allocation for Quicker Hard Handover	9
6.4 Quicker channel switching	9
6.4.1 Problem	9
6.4.2 Proposed solution	10
6.5 Quicker RL additions of RLs recently in the active set	11
6.6 Resource Reservation without allocation to a specific UE	11
6.6.1 Assumption.....	11
6.6.2 Study of the RADIO LINK SETUP REQUEST and RADIO LINK ADDITION REQUEST messages	11
6.6.2.1 Analysis of the Rel-4 NBAP message.....	11
6.6.2.2 Analysis of the RNSAP message.....	16
6.6.2.3 Discussion Points.....	20
6.6.3 Proposed Solution.....	22
6.7 Backward compatibility	23
6.8 Open issues	23
7 Agreements	24
8 Specification Impact and associated Change Requests	24
Annex A: Change History	25

Foreword

This Technical Report (TR) has been produced by the 3rd Generation Partnership Project (3GPP).

The contents of the present document are subject to continuing work within the TSG and may change following formal TSG approval. Should the TSG modify the contents of the present document, it will be re-released by the TSG with an identifying change of release date and an increase in version number as follows:

Version x.y.z

where:

- x the first digit:
 - 1 presented to TSG for information;
 - 2 presented to TSG for approval;
 - 3 or greater indicates TSG approved document under change control.
- y the second digit is incremented for all changes of substance, i.e. technical enhancements, corrections, updates, etc.
- z the third digit is incremented when editorial only changes have been incorporated in the document.

1 Scope

The purpose of the present document is to help the TSG RAN WG3 group to specify the changes to existing specifications, needed for the introduction of the Separation of resource reservation and radio link activation worktask, as proposed in [1].

The document describes the agreed requirements related to the worktask, the different areas that were studied, the agreements that were made, and it identifies the affected specifications with related Change Requests. It also describes the schedule of the worktask.

The present document is a 'living' document, i.e. it is permanently updated and presented to all TSG-RAN meetings.

2 References

The following documents contain provisions which, through reference in this text, constitute provisions of the present document.

- References are either specific (identified by date of publication and/or edition number or version number) or non-specific.
- For a specific reference, subsequent revisions do not apply.
- For a non-specific reference, the latest version applies. In the case of a reference to a 3GPP document (including a GSM document), a non-specific reference implicitly refers to the latest version of that document *in the same Release as the present document*.

- [1] RP-010487: "Separation of resource reservation and radio link activation, Work Item Description", (http://www.3gpp.org/ftp/tsg_ran/TSG_RAN/TSGR_12/Docs/PDFs/RP-010487.pdf).
- [2] 3GPP TS 34.108: "Common Test Environments for User Equipment (UE) Conformance Testing".
- [3] 3GPP TS 25.423: "UTRAN Iur Interface RNSAP Signalling".
- [4] 3GPP TS 25.433: "UTRAN Iub Interface NBAP Signalling".

3 Definitions, symbols and abbreviations

3.1 Definitions

For the purposes of the present document, the following terms and definitions apply.

3.2 Symbols

3.3 Abbreviations

For the purposes of the present document, the following abbreviations apply:

ALCAP	Access Link Control Application Protocol
CCH	Control Channel
CFN	Connection Frame Number
CRNC	Controlling Radio Network Controller
DCH	Dedicated Channel
DL	Downlink (Forward Link)
DPCH	Dedicated Physical Channel
FDD	Frequency Division Duplex

RL	Radio Link
SRNC	Serving Radio Network Controller
TDD	Time Division Duplex
UE	User Equipment

4 Introduction

As indicated in [1], this worktask aims at introducing the possibility to have dedicated resources reserved in UTRAN without transmitting energy on the corresponding radio link(s). Furthermore, a separate mechanism for activating and deactivating radio transmission related to the reserved resources shall be introduced. The study of this mechanism shall also consider the possibility to reserve resources without allocating them to a particular UE. In this case, the actual allocation of the reserved resources to a particular UE would be delayed until the activation of the radio transmission.

The separation will enable the following optimisations in UTRAN:

- Delayed activation of a radio link at soft handover for high bit rate users, thus avoiding a potential handover problem.
- Quicker channel type switching back to Cell_DCH.
- Quicker radio link additions of radio links that recently were part of the active set.
- Benefit from statistical multiplexing at RRM level (by reserving resources on a given cell based on HO probability laws, Busy Hour Call Attempts statistics, ...).

The different optimisations are described in more detail in clause 6.

5 Requirements

The following requirements are identified:

1. It shall be possible for the SRNC to request the establishment of RL's as normal, but without the activation of the transmitter for the Uu interface.
2. It shall be possible for the SRNC to command transmission of a certain RL on the Uu to be switched on at a certain CFN. This to enable synchronised activation over multiple RL's and synchronised activation between UTRAN and UE.
3. It shall be possible for the SRNC to command transmission of a certain RL on the Uu to be switched on immediately. This to enable fast activation.
4. It shall be possible for the SRNC to command transmission of a certain RL on the Uu to be switched off at a certain CFN. This to enable synchronised de-activation over multiple RL's and synchronised activation between UTRAN and UE.
5. It shall be possible for the SRNC to command transmission of a certain RL on the Uu to be switched off immediately. This to enable fast de-activation.
6. When the SRNC commands transmission of a certain RL on the Uu to be switched on, it shall be possible for the SRNC to set an initial DL power level.
7. It should be possible for the CRNC to request from a Node B the establishment of RL(s) without actually allocating them to a specific UE.
8. It should be possible to have non-activated reserved resources not allocated to any UE.
9. All the defined mechanisms shall be transparent from a Uu point of view.

6 RAN3 Study areas

6.1 General

Any new functionality introduced in R5 should be introduced with the least possible impact to the existing R99/R4 specifications.

6.2 Avoiding potential handover problem

6.2.1 Problem

Currently the Node-B is not aware of when a UE is going to attempt to obtain sync to a Radio Link in the downlink. In general, first the new RL is established in the UTRAN, and if this phase is passed successfully, the UE is informed about a new RL and requested to add it to its active set. This scenario is shown in figure 1.

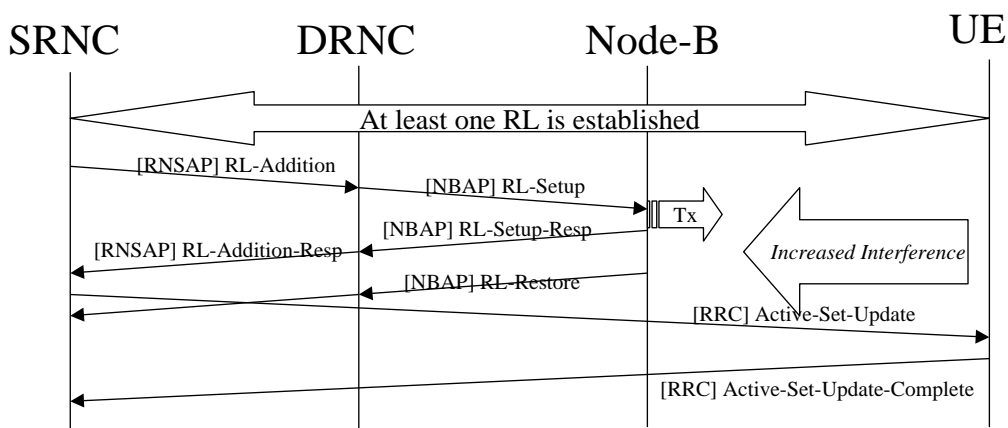

Figure 1: Current RL addition example sequence for soft handover

During the period indicated with the big arrow, the UE will experience an increased interference level due to the transmission on the new RL, since the RL is not yet part of the active set. Especially in cases where the UE already had a problem with the quality of the radio connection, the additional interference might deteriorate the situation and in the worst case make the receipt of the RRC Active-Set-Update message impossible.

6.2.2 Proposed solution

The proposed solution is to start the transmission on the new RL as late as possible, meaning just before the UE will start to attempt to receive it possibly even after transmission of the RRC Active-Set-Update message. Especially in those cases where an activation time is indicated in the RRC Active-Set-Update message, the UTRAN will be in detail aware of when the UE will really start to attempt to obtain sync on the new RL. DL transmission from the Node-B only needs to start at that CFN. In order to obtain this solution, 2 modifications to the current protocol are proposed:

1. Add a flag in the NBAP/RNSAP RL-Setup and RL-Addition, which indicates if DL transmission should start immediately or only when a separate activation command is received. The separate command could be provided with the NBAP/RNSAP DL-Power-Request message, which enables a one-shot activation without a separate response message.
2. Add a CFN in the NBAP/RNSAP RL-Setup and RL-Addition, indicating at which CFN the transmission of the RL should really start.

Both approaches are shown figures 2 and 3.

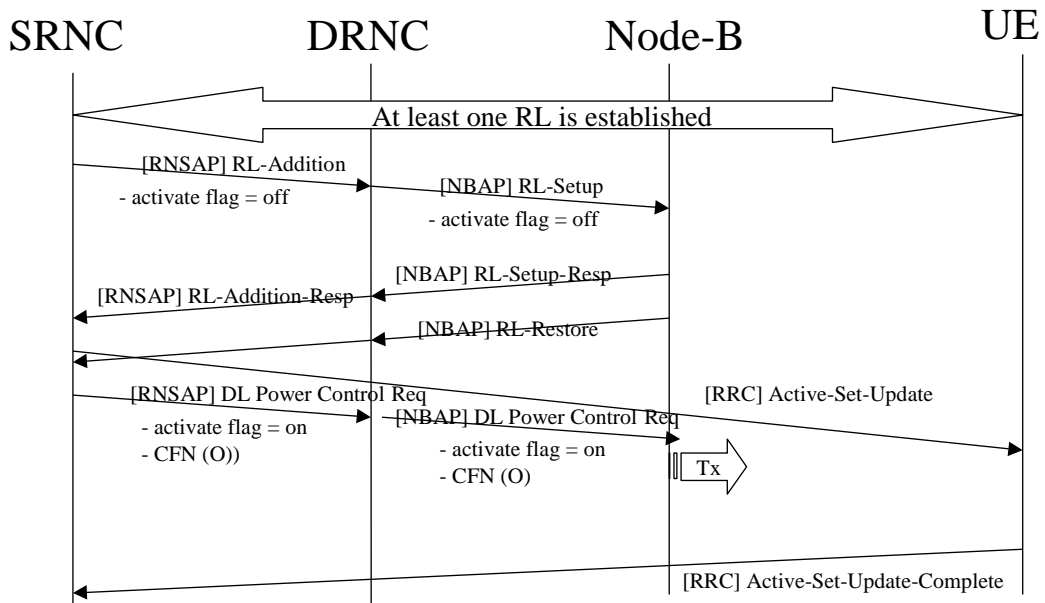

Figure 2: Use of separate TX activation

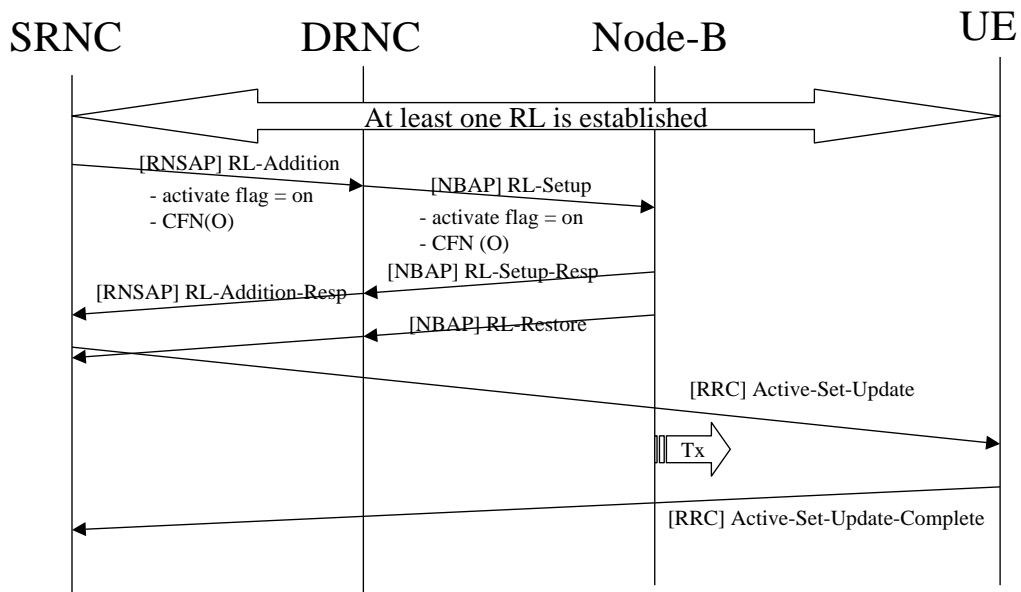

Figure 3: Use of CFN activation

In both cases, the DL transmission only starts at the "Tx-arrow. Due to the late start, the interference problem is reduced/removed.

NOTE: The DL-Power-Req message is extended with 2 new IE's as shown in figure 2. Note that although the Node-B has switched off the Tx power, it still maintains the power level knowledge, taking into account DL power balancing commands or innerloop adjustments.

6.3 Pre-allocation for Quicker Hard Handover

In the case that hard handover is to be used, pre-allocating the new radio links in anticipation of needing to perform hard handover can be desirable. This is particularly true when multiple cells may be the best candidates. It could be desirable to pre-allocate into multiple candidate cells and then the handover decision can be made quickly and optimally. However without postponing activation after reservation, each of the pre-activations will cause increased interference (on the DPCH with special bursts in TDD, and the DPCCH in FDD) in the cell or even in cells that never have this radio link used.. The scenario is similar to figure 1, except that the increased interference occurs in other cells so it does not affect the UE in question but UEs in the cell or cells with the pre-allocated radio link. Since this scenario should not result in any additional protocol requirements, it is therefore not discussed in more detail.

6.4 Quicker channel switching

6.4.1 Problem

When establishing a dedicated RL, a lot of resources have to be reserved in the UTRAN. If we e.g. talk about a new RL in the DRNS, with a speech call, the following resources need to be allocated:

- 1) Application level resource reservations in DRNC.
- 2) Application level resource reservations in Node-B.
- 3) Transport bearer for signalling bearer over Iur.
- 4) Transport bearer for signalling bearer over Iub.
- 5) Transport bearer for speech data bearer over Iur.
- 6) Transport bearer for speech data bearer over Iub.

1 & 2 are established with the RL setup procedure in this example. Reservations 3 - 6 are made with ALCAP signalling. This is shown in figure 4.

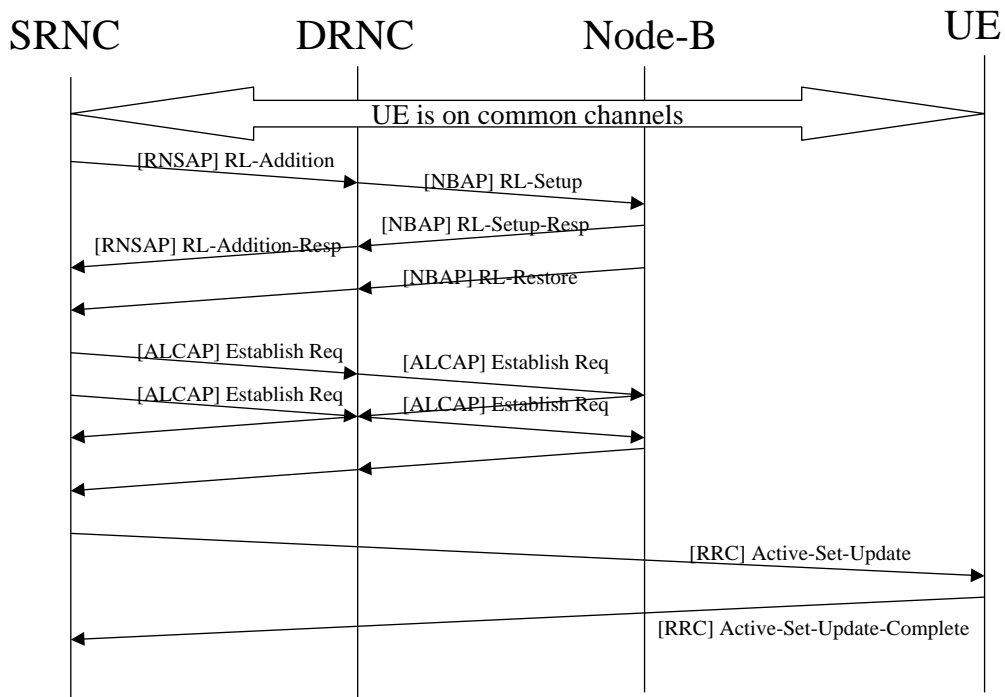

Figure 4: Signalling for RL-Setup (CCH to DCH switching)

Note that the ALCAP signalling was absent in the previous figures.

Also in the case when switching between common and dedicated channel state, this is the signalling that needs to take place. It is clear that this signalling will delay fast channel switching between common and dedicated channel state.

6.4.2 Proposed solution

Based on what is described in subclause 3.2.2, the solution is quite simple. The first time when a UE switches from DCH to CCH state, the resources in the UTRAN are not deleted. In stead only the DL TX is switched off.

When the UE moves from CCH to DCH again, the only thing that is needed is switching on the DL TX power.

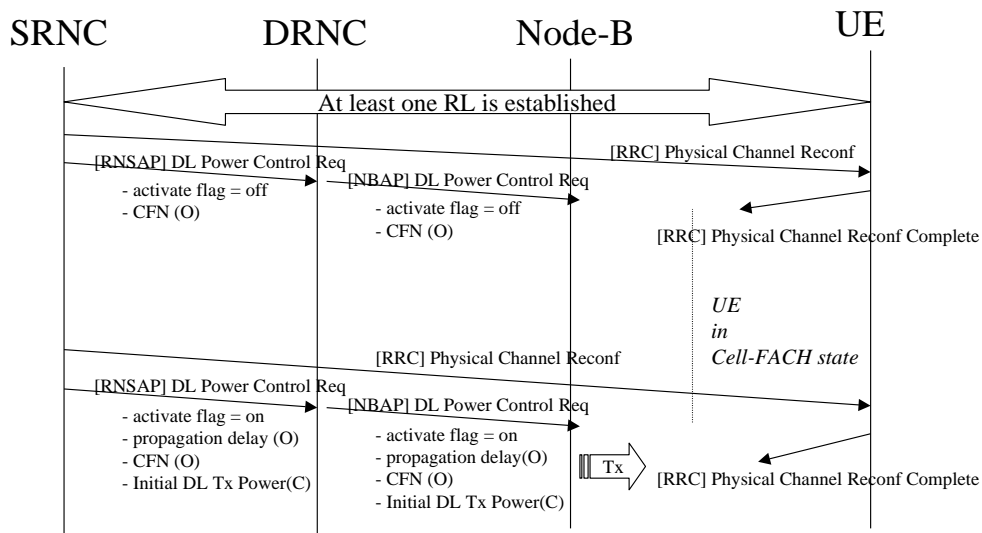

Figure 5: One-shot DL transmit power de-activation/activation (FDD)

Comparing the one-shot activation in figure 5 with the large number of messages required in figure 4, it should be clear that a delay decrease can be obtained.

Figure 6 shows a similar solution for TDD.

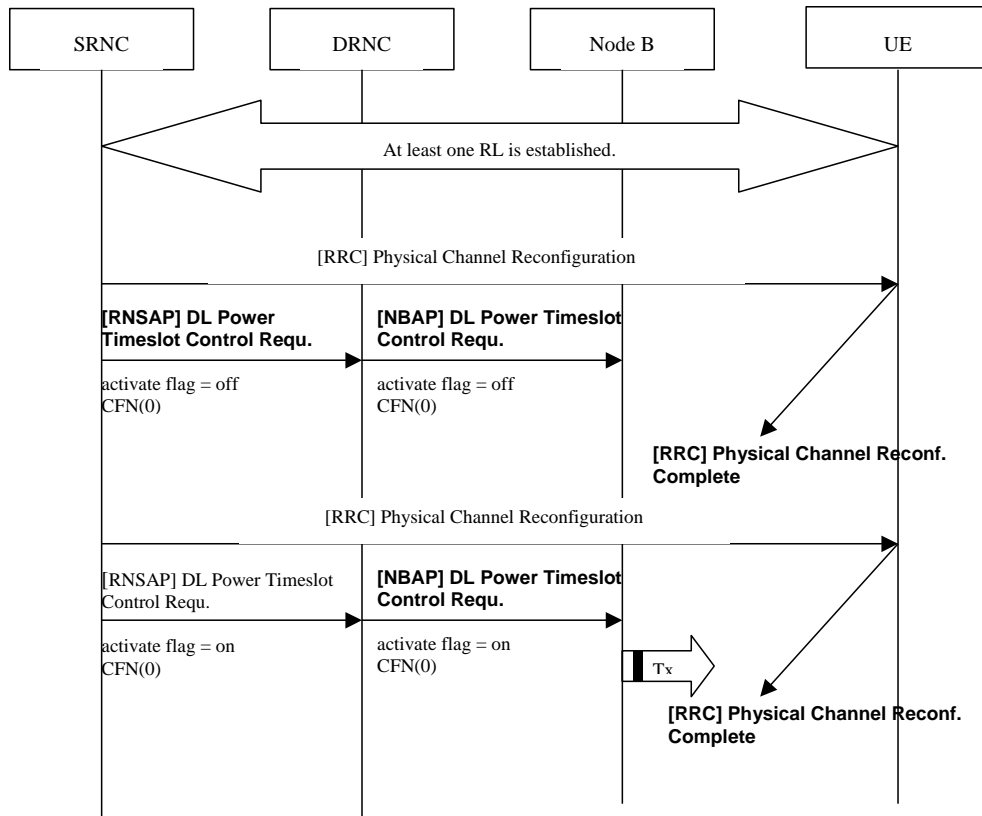

Figure 6: One-shot DL transmit power de-activation/activation(TDD)

6.5 Quicker RL additions of RLs recently in the active set

This optimisation should not result in any additional protocol requirements, and is therefore not discussed in more detail. The scenario will be very similar to the scenario in figure 5.

6.6 Resource Reservation without allocation to a specific UE

6.6.1 Assumption

The principle of RL Delayed Activation is enticing as it allows to reduce interferences in the Handover period, anticipate the need for a new RL in Soft Handover (thus decreasing the Call Dropped Rate for instance) or quicken the change from Cell-FACH to Cell-DCH state.

Furthermore, although UMTS provides a toolkit offering the flexibility of a vast number of different configurations, the reality of a network run by an operator is that there will be a handful of supported RAB configurations.

The main assumption of this study is that this particular part of the delayed activation will be used for common configurations. It will still be possible to reserve resources for uncommon configurations through the normal RL Setup procedure (which means that these resources will be allocated) or through another delayed activation mechanism (such as resource reservation for a particular UE).

6.6.2 Study of the RADIO LINK SETUP REQUEST and RADIO LINK ADDITION REQUEST messages

6.6.2.1 Analysis of the Rel-4 NBAP message

The last column in this table indicates whether the IE can be considered as UE-specific or not.

FDD RADIO LINK SETUP REQUEST message:

Table 1: FDD RADIO LINK SETUP REQUEST NBAP message

IE/Group Name	Presence	Range	IE type and reference	Criticality	Assigned Criticality	UE-specific
Message Discriminator	M		9.2.1.45	–		
Message Type	M		9.2.1.46	YES	reject	
CRNC Communication Context ID	M		9.2.1.18	YES	reject	No ¹
Transaction ID	M		9.2.1.62	–		
UL DPCH Information		1		YES	reject	
>UL Scrambling Code	M		9.2.2.59	–		Yes
>Min UL Channelisation Code length	M		9.2.2.22	–		No ²
>Max Number of UL DPDCHs	C – CodeLen		9.2.2.21	–		No ²
>puncture Limit	M		9.2.1.50	–		No
>TFCS	M		9.2.1.58	–		No
>UL DPCH Slot Format	M		9.2.2.57	–		No
> UL SIR Target	M		UL SIR 9.2.2.58	–		No ³
>Diversity mode	M		9.2.2.9	–		No ³
>SSDT cell ID Length	O		9.2.2.45	–		No ³
>S Field Length	C-FBI		9.2.2.40	–		No ³
>DPC mode	O		9.2.2.13C			No
DL DPCH Information		1		YES	reject	
>TFCS	M		9.2.1.58	–		No
>DL DPCH Slot Format	M		9.2.2.10	–		No
>TFCI signalling mode	M		9.2.2.50	–		No
>TFCI presence	C- SlotFormat		9.2.1.57	–		No
>Multiplexing Position	M		9.2.2.23	–		No
>PDSCH RL ID	C-DSCH		RL ID 9.2.1.53	–		No ⁶
>PDSCH code mapping	C-DSCH		9.2.2.25	–		No ⁶
>Power Offset Information		1		–		
>>PO1	M		Power Offset 9.2.2.29	–		No
>>PO2	M		Power Offset 9.2.2.29	–		No
>>PO3	M		Power Offset 9.2.2.29	–		No
>FDD TPC DL Step Size	M		9.2.2.16	–		No
>Limited Power Increase	M		9.2.2.18A	–		No
>Inner Loop DL PC Status	M		9.2.2.18B	–		No
DCH Information	M		DCH FDD Information 9.2.2.4D	YES	reject	No
DSCH Information	O		DSCH FDD Information 9.2.2.13B	YES	reject	No ⁶
TFCI2 bearer information		0..1		YES	ignore	No ⁶
>ToAWS	M		9.2.1.61	–		No
>ToAWE	M		9.2.1.60	–		No
RL Information		1 to <maxnoo fRLs>		EACH	notify	

IE/Group Name	Presence	Range	IE type and reference	Criticality	Assigned Criticality	UE-specific
>RL ID	M		9.2.1.53	–		No ¹¹
>C-ID	M		9.2.1.9	–		No
>First RLS Indicator	M		9.2.2.16A	–		No ⁹
>Frame Offset	M		9.2.1.31	–		Yes
>Chip Offset	M		9.2.2.2	–		Yes
>Propagation Delay	O		9.2.2.35	–		Yes
>Diversity Control Field	C – NotFirstRL		9.2.1.25	–		No ⁷
>DL Code Information	M		FDD DL Code Information 9.2.2.14A	–		No ^{4,5,10}
>Initial DL transmission Power	M		DL Power 9.2.1.21	–		No ⁹
>Maximum DL power	M		DL Power 9.2.1.21	–		No
>Minimum DL power	M		DL Power 9.2.1.21	–		No
>SSDT Cell Identity	O		9.2.2.44	–		Yes
>Transmit Diversity Indicator	C – Diversity mode		9.2.2.53	–		No
>SSDT Cell Identity for EDSCHPC	C- EDSCHPC		9.2.2.40A	YES	ignore	Yes
Transmission Gap Pattern Sequence Information	O		9.2.2.53A	YES	reject	No ⁴
Active Pattern Sequence Information	O		9.2.2.A	YES	reject	No ⁴
DSCH Common Information	O		DSCH FDD Common Information 9.2.2.13D	YES	ignore	No ⁶

TDD RADIO LINK SETUP REQUEST message:

Table 2: TDD RADIO LINK SETUP REQUEST NBAP message

IE/Group Name	Presence	Range	IE type and reference	Criticality	Assigned Criticality	UE-specific
Message Discriminator	M		9.2.1.45	–		
Message Type	M		9.2.1.46	YES	reject	
CRNC Communication Context ID	M		9.2.1.18	YES	reject	No ¹
Transaction ID	M		9.2.1.62	–		
UL CCTrCH Information		0 to <maxno CCTrCH>		EACH	notify	
>CCTrCH ID	M		9.2.3.3	–		No
>TFCS	M		9.2.1.58	–		No
>TFCI Coding	M		9.2.3.22	–		No
>Puncture Limit	M		9.2.1.50	–		No
> UL SIR Target	O		UL SIR 9.2.1.67A	YES	reject	No
>UL DPCH Information		0..1		YES	notify	
>>Repetition Period	M		9.2.3.16	–		No
>>Repetition Length	M		9.2.3.15	–		No
>>TDD DPCH Offset	M		9.2.3.19A	–		No

IE/Group Name	Presence	Range	IE type and reference	Criticality	Assigned Criticality	UE-specific
>>UL Timeslot Information	M		9.2.3.26C	–		No ¹²
>UL DPCH Information LCR		0..1		YES	notify	
>>Repetition Period	M		9.2.3.16	–		No
>>Repetition Length	M		9.2.3.15	–		No
>>TDD DPCH Offset	M		9.2.3.19A	–		No
>>UL Timeslot Information LCR	M		9.2.3.26E	–		No ¹²
DL CCTrCH Information		0 to <maxno CCTrCH>		EACH	notify	
>CCTrCH ID	M		9.2.3.3	–		No
>TFCS	M		9.2.1.58	–		No
>TFCI Coding	M		9.2.3.22	–		No
>Puncture Limit	M		9.2.1.50	–		No
>TDD TPC DL Step Size	M		9.2.3.21	–		No
>TPC CCTrCH List		0 to <maxnoCC TrCH>		–		
>>TPC CCTrCH ID	M		CCTrCH ID 9.2.3.3	–		No
>DL DPCH information		0..1		YES	notify	
>>Repetition Period	M		9.2.3.16	–		No
>>Repetition Length	M		9.2.3.15	–		No
>>TDD DPCH Offset	M		9.2.3.19A	–		No
>>DL Timeslot Information	M		9.2.3.4E	–		No ¹²
>DL DPCH information LCR		0..1		YES	notify	
>>Repetition Period	M		9.2.3.16	–		No
>>Repetition Length	M		9.2.3.15	–		No
>>TDD DPCH Offset	M		9.2.3.19A	–		No
>>DL Timeslot Information LCR	M		9.2.3.4O	–		No ¹²
>>TSTD Indicator	M		9.2.1.64	–		No
DCH Information	O		DCH TDD Information 9.2.3.4C	YES	reject	No
DSCH Information	O		DSCH TDD Information 9.2.3.5A	YES	reject	No ⁹
USCH Information	O		9.2.3.28	YES	reject	No
RL Information		1		YES	reject	
>RL ID	M		9.2.1.53	–		No ¹¹
>C-ID	M		9.2.1.9	–		No
>Frame Offset	M		9.2.1.31	–		Yes
>Special Burst Scheduling	M		9.2.3.18A	–		No
>Initial DL transmission Power	M		DL Power 9.2.1.21	–		No
>Maximum DL power	M		DL Power 9.2.1.21	–		No
>Minimum DL power	M		DL Power 9.2.1.21	–		No
>DL Time Slot ISCP Info	O		9.2.3.4F	–		Yes
>DL Time Slot ISCP Info LCR	O		9.2.3.40A	YES	reject	Yes

FDD RADIO LINK ADDITION REQUEST message:

Table 3: FDD RADIO LINK ADDITION REQUEST NBAP message

IE/Group Name	Presence	Range	IE type and reference	Criticality	Assigned Criticality	UE-specific
Message Discriminator	M		9.2.1.45	–		
Message Type	M		9.2.1.46	YES	reject	
Node B Communication Context ID	M		9.2.1.48	YES	reject	No ¹
Transaction ID	M		9.2.1.62	–		
Compressed Mode Deactivation Flag	O		9.2.2.3A	YES	reject	Yes ⁴
RL Information		1..<maxno ofRL-1>		EACH	notify	
>RL ID	M		9.2.1.53	–		No ¹¹
>C-ID	M		9.2.1.9	–		No
>Frame Offset	M		9.2.1.31	–		Yes
>Chip Offset	M		9.2.2.2	–		Yes
>Diversity Control Field	M		9.2.1.25	–		No ⁷
>DL Code Information	M		FDD DL Code Information 9.2.2.14A	–		No ^{4,5,10}
>Initial DL transmission power	O		DL Power 9.2.1.21	–		No ⁹
>Maximum DL power	O		DL Power 9.2.1.21	–		No
>Minimum DL power	O		DL Power 9.2.1.21	–		No
>SSDT Cell Identity	O		9.2.2.44	–		Yes
>Transmit Diversity Indicator	O		9.2.2.53	–		No

TDD RADIO LINK ADDITION REQUEST message:

Table 4: TDD RADIO LINK ADDITION REQUEST NBAP message

IE/Group Name	Presence	Range	IE type and reference	Criticality	Assigned Criticality	UE-specific
Message Discriminator	M		9.2.1.45	–		
Message Type	M		9.2.1.46	YES	reject	
Node B Communication Context ID	M		9.2.1.48	YES	reject	No ¹
Transaction ID	M		9.2.1.62	–		
UL CTrCH Information		0 to <maxno CTrCH>		GLOBAL	reject	
>CTrCH ID	M		9.2.3.3	–		No
>UL DPCH Information		0..1		YES	notify	
>>Repetition Period	M		9.2.3.16	–		No
>>Repetition Length	M		9.2.3.15	–		No
>>TDD DPCH Offset	M		9.2.3.19A	–		No
>>UL Timeslot Information	M		9.2.3.26C	–		No ¹²
>UL DPCH Information LCR		0..1		YES	notify	
>>Repetition Period	M		9.2.3.16	–		No
>>Repetition Length	M		9.2.3.15	–		No
>>TDD DPCH Offset	M		9.2.3.19A	–		No
>>UL Timeslot Information LCR	M		9.2.3.26E	–		No ¹²
DL CTrCH Information		0 to <maxno CTrCH>		GLOBAL	reject	

IE/Group Name	Presence	Range	IE type and reference	Criticality	Assigned Criticality	UE-specific
		H>				
>CCTrCH ID	M		9.2.3.3	–		No
>DL DPCH information		0..1		YES	notify	
>>Repetition Period	M		9.2.3.16	–		No
>>Repetition Length	M		9.2.3.15	–		No
>>TDD DPCH Offset	M		9.2.3.19A	–		No
>>DL Timeslot Information	M		9.2.3.4E	–		No ¹²
>DL DPCH information LCR		0..1		YES	notify	
>>Repetition Period	M		9.2.3.16	–		No
>>Repetition Length	M		9.2.3.15	–		No
>>TDD DPCH Offset	M		9.2.3.19A	–		No
>>DL Timeslot Information LCR	M		9.2.3.4O	–		No ¹
RL Information		1		YES	reject	
>RL ID	M		9.2.1.53	–		No ¹¹
>C-ID	M		9.2.1.9	–		No
>Frame Offset	M		9.2.1.31	–		Yes
>Diversity Control Field	M		9.2.1.25	–		No ⁷
>Initial DL transmission Power	O		DL Power 9.2.1.21	–		No ⁹
>Maximum DL power	O		DL Power 9.2.1.21	–		No
>Minimum DL power	O		DL Power 9.2.1.21	–		No
>DL Time Slot ISCP Info	O		9.2.3.4F	–		Yes
>DL Time Slot ISCP Info LCR	O		9.2.3.40A	YES	reject	Yes

NOTE 1: The reserved RL(s) is(are) attached to the CRNC Communication Context/Node B Communication Context, allocation to the UE can be done later.

NOTE 2: Discussion point on "Maxnumber of DPDCH data bits/radio frame".

NOTE 3: As the support of Diversity Modes is mandatory for the UEs but not for the UTRAN.

NOTE 4: Discussion point on Compressed Mode.

NOTE 5: Discussion Point on MultiCode.

NOTE 6: Discussion Point on presence of DSCH-related IEs.

NOTE 7: Discussion Point on RL Combining Issues.

NOTE 8: Although not UE-specific, this IE will have to be present at the time of the Radio Link Activation as it relates to the Uu Synchronisation procedures.

NOTE 9: Although not UE-specific, it would be better to have this IE at the time of the activation of the RL as this may relate to conditions applicable at the activation instant and not at the time of the reservation.

NOTE 10: Discussion Point on DL Code Information.

NOTE 11: However, this IE needs to be present to identify the concerned Radio Link.

NOTE 12: *UL Timeslot Information, DL Timeslot Information, UL Timeslot Information LCR, DL Timeslot Information LCR* IEs contain the *Midamble Allocation Mode* IE and this can have value "UE specific midamble". Anyhow, this value is only used for beamforming and as the support of Diversity Modes is mandatory for the UEs, but not for the UTRAN, we can consider this IEs as non UE-specific.

6.6.2.2 Analysis of the RNSAP message

The last column in this table indicates whether the IE can be considered as UE-specific or not.

FDD RADIO LINK SETUP REQUEST message:

Table 5: FDDRADIO LINK SETUP REQUEST RNSAP message

IE/Group Name	Presence	Range	IE type and reference	Criticality	Assigned Criticality	UE-specific
Message Type	M		9.2.1.40	YES	reject	
Transaction ID	M		9.2.1.59	–		
SRNC-Id	M		RNC-Id 9.2.1.50	YES	reject	No
S-RNTI	M		9.2.1.53	YES	reject	Yes
D-RNTI	O		9.2.1.24	YES	reject	Yes
Allowed Queuing Time	O		9.2.1.2	YES	reject	No
UL DPCH Information		1		YES	reject	
>UL Scrambling Code	M		9.2.2.53	–		Yes
>Min UL Channelisation Code Length	M		9.2.2.25	–		No ¹
>Max Number of UL DPCHs	C – CodeLen		9.2.2.24	–		No ¹
>Puncture Limit	M		9.2.1.46	–		No
>TFCS	M		TFCS for the UL 9.2.1.63	–		No
>UL DPCH Slot Format	M		9.2.2.52	–		No
>Uplink SIR Target	O		Uplink SIR 9.2.1.69	–		No ⁸
>Diversity mode	M		9.2.2.8	–		No ²
>SSDT Cell Identity Length	O		9.2.2.41	–		No ²
>S Field Length	O		9.2.2.36	–		No ²
>DPC Mode	O		9.2.2.12A	YES	reject	No
DL DPCH Information		1		YES	reject	
>TFCS	M		TFCS for the DL. 9.2.1.63	–		No
>DL DPCH Slot Format	M		9.2.2.9	–		No
>Number of DL Channelisation Codes	M		9.2.2.26A	–		No ⁴
>TFCI Signalling Mode	M		9.2.2.46	–		No
>TFCI Presence	C- SlotFormat		9.2.1.55	–		No
>Multiplexing Position	M		9.2.2.26	–		No
>Power Offset Information		1		–		
>>PO1	M		Power Offset 9.2.2.30	–		No
>>PO2	M		Power Offset 9.2.2.30	–		No
>>PO3	M		Power Offset 9.2.2.30	–		No
>FDD TPC Downlink Step Size	M		9.2.2.16	–		No
>Limited Power Increase	M		9.2.2.21A	–		No
>Inner Loop DL PC Status	M		9.2.2.21a	–		No
DCH Information	M		DCH FDD Information 9.2.2.4A	YES	reject	No
DSCH Information	O		DSCH FDD Information 9.2.2.13A	YES	reject	No ⁹
RL Information		1...<max noofRLs >		EACH	notify	

IE/Group Name	Presence	Range	IE type and reference	Criticality	Assigned Criticality	UE-specific
>RL ID	M		9.2.1.49	–		No ⁸
>C-Id	M		9.2.1.6	–		No
>First RLS Indicator	M		9.2.2.16A	-		No ⁷
>Frame Offset	M		9.2.1.30	–		Yes
>Chip Offset	M		9.2.2.1	–		Yes
>Propagation Delay	O		9.2.2.33	–		Yes
>Diversity Control Field	C – NotFirstRL		9.2.1.20	–		No ⁹
>Initial DL TX Power	C		DL Power 9.2.1.21A	–		No ⁹
>Primary CPICH Ec/No	C		9.2.2.32	–		Yes
>SSDT Cell Identity	O		9.2.2.40	–		No ²
>Transmit Diversity Indicator	C – Diversity mode		9.2.2.48	–		No
>SSDT Cell Identity for EDSCHPC	C-EDSCHPC		9.2.2.40A	YES	ignore	No ²
Transmission Gap Pattern Sequence Information	C		9.2.2.47A	YES	reject	No ³
Active Pattern Sequence Information	O		9.2.2.A	YES	reject	No ³
Permanent NAS UE Identity	O		9.2.1.31	YES	ignore	Yes

TDD RADIO LINK SETUP REQUEST message:

Table 6: TDD RADIO LINK SETUP REQUEST RNSAP message

IE/Group Name	Presence	Range	IE type and reference	Criticality	Assigned Criticality	UE-specific
Message Type	M		9.2.1.40	YES	reject	
Transaction ID	M		9.2.1.59	–		
SRNC-Id	M		RNC-Id 9.2.1.50	YES	reject	No
S-RNTI	M		9.2.1.53	YES	reject	Yes
D-RNTI	O		9.2.1.24	YES	reject	Yes
Allowed Queuing Time	O		9.2.1.2	YES	reject	No
UL Physical Channel Information		1		YES	reject	
>Maximum Number of Timeslots per Frame	M		9.2.3.3A	–		No ¹
>Minimum Spreading Factor	M		9.2.3.4A	–		No ¹
>Maximum Number of UL Physical Channels per Timeslot	M		9.2.3.3B	–		No ¹
DL Physical Channel Information		1		YES	reject	
>Maximum Number of Timeslots per Frame	M		9.2.3.3A	–		No ¹
>Minimum Spreading Factor	M		9.2.3.4A	–		No ¹
>Maximum Number of DL Physical Channels per Frame	M		9.2.3.3C	–		No ¹
UL CTrCH Information		0..<maxnoo fCCTrCHs>		EACH	notify	
>CCTrCH ID	M		9.2.3.2	–		No
>TFCS	M		9.2.1.63	–		No
>TFCI Coding	M		9.2.3.11	–		No
>Puncture Limit	M		9.2.1.46	–		No
>UL SIR Target	O		Uplink SIR 9.2.1.69	YES	reject	No
DL CTrCH Information		0..<maxnoo fCCTrCHs>		EACH	notify	

IE/Group Name	Presence	Range	IE type and reference	Criticality	Assigned Criticality	UE-specific
>CCTrCH ID	M		9.2.3.2	–		No
>TFCS	M		9.2.1.63	–		No
>TFCI Coding	M		9.2.3.11	–		No
>Puncture Limit	M		9.2.1.46	–		No
>TDD TPC Downlink Step Size	M		9.2.3.10	–		No
>TPC CCTrCH List		0 to <maxnoCC TrCH>		–		
>>TPC CCTrCH ID	M		CCTrCH ID 9.2.3.2	–		No
DCH Information	O		DCH TDD Information 9.2.3.2A	YES	reject	No
DSCH Information	O		DSCH TDD Information 9.2.3.3a	YES	reject	No ^o
USCH Information	O		9.2.3.15	YES	reject	No
RL Information		1		YES	reject	
>RL ID	M		9.2.1.49	–		No ^o
>C-Id	M		9.2.1.6	–		No
>Frame Offset	M		9.2.1.30	–		Yes
>Special Burst Scheduling	M		9.2.3.7D	–		No
>Primary CCPCH RSCP	O		9.2.3.5	–		Yes
>DL Time Slot ISCP Info	O		9.2.3.2D	–		Yes
>DL Time Slot ISCP Info LCR	O		9.2.3.2F	YES	reject	Yes
>TSTD Support Indicator	O		9.2.3.13F	YES	ignore	No
Permanent NAS UE Identity	O		9.2.1.31	YES	ignore	Yes

FDD RADIO LINK ADDITION REQUEST message:

Table 7: FDD RADIO LINK ADDITION REQUEST RNSAP message

IE/Group Name	Presence	Range	IE type and reference	Criticality	Assigned Criticality	UE-specific
Message Type	M		9.2.1.40	YES	reject	
Transaction ID	M		9.2.1.59	–		
Uplink SIR Target	M		Uplink SIR 9.2.1.69	YES	reject	No ^o
RL Information		1..<maxno ofRLs-1>		EACH	notify	
>RL ID	M		9.2.1.49	–		No ^o
>C-Id	M		9.2.1.6	–		No
>Frame Offset	M		9.2.1.30	–		Yes
>Chip Offset	M		9.2.2.1	–		Yes
>Diversity Control Field	M		9.2.1.20	–		No ^o
>Primary CPICH Ec/No	O		9.2.2.32	–		Yes
>SSDT Cell Identity	O		9.2.2.40			Yes
>Transmit Diversity Indicator	O		9.2.2.48	–		No
Active Pattern Sequence Information	O		9.2.2A	YES	reject	No ^o
DPC Mode	O		9.2.2.12A	YES	reject	No ^o
Permanent NAS UE Identity	O		9.2.1.73	YES	ignore	Yes

TDD RADIO LINK ADDITION REQUEST message:**Table 8: TDD RADIO LINK ADDITION REQUEST RNSAP message**

IE/Group Name	Presence	Range	IE type and reference	Criticality	Assigned Criticality	UE-specific
Message Type	M		9.2.1.40	YES	reject	
Transaction ID	M		9.2.1.59	–		
RL Information		1		YES	reject	
>RL ID	M		9.2.1.49	–		No ^o
>C-Id	M		9.2.1.6	–		No
>Frame Offset	M		9.2.1.30	–		Yes
>Diversity Control Field	M		9.2.1.20	–		No ^o
>Primary CCPCH RSCP	O		9.2.3.5	–		Yes
>DL Time Slot ISCP Info	O		9.2.3.2D	–		Yes
>DL Time Slot ISCP Info LCR	O		9.2.3.2F	YES	reject	Yes
Permanent NAS UE Identity	O		9.2.1.73	YES	ignore	Yes

NOTE 1: Discussion point on "Max number of DPDCH data bits/radio frame" in the subclause below.

NOTE 2: As the support of Diversity Modes is mandatory for the UEs but not for the UTRAN.

NOTE 3: Discussion point on Compressed Mode in the subclause below.

NOTE 4: Discussion Point on MultiCode in the subclause below.

NOTE 5: Discussion Point on presence of DSCH-related IEs in the subclause below.

NOTE 6: Discussion Point on RL Combining Issues in the subclause below.

NOTE 7: Although not UE-specific, this IE will have to be present at the time of the Radio Link Activation as it relates to the Uu Synchronisation procedures.

NOTE 8: Although not UE-specific, it would be better to have this IE at the time of the activation of the RL as this may relate to conditions applicable at the activation instant and not at the time of the reservation.

NOTE 9: However, this IE needs to be present to identify the concerned Radio Link.

6.6.2.3 Discussion Points

Max number of DPDCH data bits/radio frame:

The "Max number of DPDCH data bits/radio frame" is a UE Capability with the following values: 600, 1 200, 2 400, 4 800, 9 600, 19 200, 28 800, 38 400, 48 000 and 57 600.

The *Max Number of UL DPDCHs* and *Min UL Channelisation Code Length* IEs are a way of representing this UE Capability:

- If "Max number of DPDCH data bits/radio frame" \leq 9 600, then *Max Number of UL DPDCHs* = 1 and *Min UL Channelisation Code Length* has a value among 4, 8, 16, 32 and 64.
- If "Max number of DPDCH data bits/radio frame" $>$ 9 600, then *Min UL Channelisation Code Length* = 4 and *Max Number of UL DPDCHs* has a value between 1 and 6.

However, when going through TS 34.108, there is no value for "Max number of DPDCH data bits/radio frame" greater than 9 600. The value 9 600 is used for the following scenario: "UL: 384 DL: 384 kbps / PS RAB + UL: 34 DL: 3.4 kbps SRBs for DCCH" or "UL: 64 DL: 64 kbps / CS RAB + UL: 128 DL: 128 kbps / PS RAB + UL: 3.4 DL: 3.4 kbps SRBs for DCCH".

Making the assumption that the RAB configurations proposed for the majority of the UEs will be supported by them (especially for the Max number of DPDCH data bits/radio frame UE Capability), we can pre-configure these parameters.

Compressed Mode:

1. There is no UE Capability related to the Compressed Mode except for the fact that Compressed Mode is needed by a UE in DL or UL for one Measurement Purpose or another. As such there is no constraint related to a UE on the *Transmission Gap Pattern Sequence Information* IE. So this IE can be considered as non UE-specific.
2. The *Active Pattern Sequence Information* IE is used to activate a Transmission Gap Pattern Sequence on the new RL that is already active on the existing Radio Links. Furthermore, the activation time is based on CFN which is a UE-specific parameter. As such, if the activation of the RL is delayed, the activation of the Compressed Mode should be delayed and thus, although this IE is present in the RADIO LINK SETUP REQUEST message, it shall be ignored. From a general point of view, Compressed Mode should be activated at the time of the activation of the Radio Link, which means that the *Active Pattern Sequence Information* IE should be present as an Optional IE in the message used for the RL Activation.
3. The *DL Code Information* IE can contain the *Transmission Gap Pattern Sequence Code Information* IE even though the RL is not allocated to a UE as this is a purely RRM decision based on the occupation of the OVFSF Code Tree. This situation can change and in this case, the configuration can be changed for an unallocated RL using the Unsynchronised (or Synchronised) RL Reconfiguration.
4. The value of the *Compressed Mode Deactivation Flag* IE is dependent on whether Compressed Mode is already active for the UE on Cells with the same UL & DL UARFCN as the one on which the RL is to be activated. Thus the IE should, in principle, be present in the RL Activation message. However, the role of this IE would be redundant with the role of the *Active Pattern Sequence Information* IE, thus the RL Activation message could do without the *Compressed Mode Deactivation Flag* IE, provided the procedure text for the *Active Pattern Sequence Information* IE.

Multicode:

According to the assumption above, we can pre-configure these parameters.

Presence of DSCH-related IEs :

According to the assumption above, we can pre-configure these parameters.

RL Combining Issues:

The fact that several RLs can be combined in the Node B (or the DRNC for the case of RNSAP) can be an issue. Combining Radio Links offers several advantages such as reducing the data traffic over Iub (or Iur) but it can also improve the quality of the UL Data transferred by the Node B to the RNC. The resource reservation mechanism discussed here is two-fold: one part is a reservation in terms of Radio Resources and the other part is a reservation in terms of Iub transport resources.

There are several more or less complex possibilities, considering the fact that the Node B guarantees that once the resource is reserved it can be activated (except in case of failure):

- Not offering the possibility to combine RLs for reserved resources. The standard Radio Link Addition procedure can then be used.
- Combining RLs in the Node B is allowed for reserved resources, but there cannot be any over-booking on the reserved radio resources considering all the Communication Contexts for which resources are reserved.
- Combining RLs in the Node B is allowed for reserved resources and it is possible to perform over-booking as long as the Node B guarantees that all the possible combinations of compatible configurations (i.e. configurations for which there is no over-booking in terms of radio resources) can be activated.

For the sake of simplicity, it is proposed to handle Radio Link Combining as it is handled in R99/Re14, i.e. resources can be reserved with Combined Radio Links over Iub (and/or Iur), but this shall be done without any overbooking in the OVFSF tree in the CRNC. For details, see subclause 6.5.3.

DL Code Information:

The reservation of the DL Scrambling Code + DL Channelisation Code is part of the resource reservation phase. Thus it has to be considered at the time of the Radio Link Setup.

6.6.3 Proposed Solution

The general principle of the proposed solution consists in performing the Resource Reservation from an RNC to a Node B (without the RNC being necessarily the CRNC of the considered Node B) just as it is done in Release 4. This is done by using the Radio Link Setup procedure in RNSAP and NBAP, the only difference in the usage of this procedure is that the Radio Link is not activated and values for UE-specific IEs in the message should not be taken into account. This will allow, for e.g. fast channel switching, to have all the relevant information present in the SRNC (including DL Code Information). Furthermore, it also allows to use all the other features such as Radio Link Combining.

It is proposed to adopt the simplest approach and not to perform any overbooking in the allocation of Radio Resources in the DRNC for the following reasons:

- Allocation of DL Codes from the OVFSF tree is handled by the DRNC.
- Resource reservations can be performed by several RNCs (in the SRNC role) on the same Node B.
- Radio Link Activation should be achieved through a Class 2 procedure, which means response and failure cases must be avoided. Thus, all the information a DRNC has to provide to an SRNC will be provided at the time of the resource reservation.

It is proposed to:

1. Put a "Delayed Activation" flag in the RADIO LINK SETUP REQUEST and the RADIO LINK ADDITION REQUEST RNSAP and NBAP messages. Backward Compatibility would be insured by setting the presence of this new IE (in the extension container of the message) as Optional. The presence of the *Delayed Activation* IE in the RADIO LINK SETUP REQUEST or the RADIO LINK ADDITION REQUEST message indicates that the activation of the Radio Link for which resources have been reserved will be triggered by a Control Plane message.
The Criticality of the IE shall be set to Reject in order to prevent Release 4 RNCs/Node Bs not comprehending this IE from establishing an active Radio Link that will not be used but will create more interferences (this would result in exactly the opposite of the intention of the Delayed Activation). In addition it shall be specified that Rel-5 nodes understanding the IE but not supporting the feature, shall reject the request. In order to prevent unnecessary rejections, support for delayed activation shall be exchanged as a cell capability over Iur.
2. The IEs that have been identified as UE-specific in the RADIO LINK SETUP REQUEST RNSAP/NBAP message shall be ignored by the DRNC (in RNSAP) or the Node B (in NBAP).
3. Create a RADIO LINK ACTIVATION COMMAND message in RNSAP and NBAP containing IEs that have been identified as UE-specific as well as the *Active Pattern Sequence Information* as an optional IE. It would also be interesting to include Power Balancing related IEs as optional IEs in this new message.

There are two solutions for handling both the FDD and TDD modes: the RADIO LINK ACTIVATION COMMAND can either be common to both modes or specific to FDD and TDD (as this is a newly introduced message). In this proposition, it is considered that it would be better to introduce separate FDD and TDD messages as parameters specific to a DD mode should be present in this message (e.g. the *Active Pattern Sequence Information* as an optional IE for FDD, *DL Timeslot ISCP* or *DL Timeslot ISCP LCR* as optional IEs in TDD). This would also allow to follow the philosophy adopted for the messages in the Radio Link Setup and Radio Link Addition procedures.

After receiving the RADIO LINK SETUP RESPONSE message, the relevant transport bearers will be established. In order to anticipate the transport bearer synchronisation that will have to be performed at the time of the activation of the Radio Link (based on the *Frame Offset* and *Chip Offset* IEs), DL & UL Synchronisation control frames can be used to determine the timing on these transport bearers.

The proposed solution is shown in figure 7.

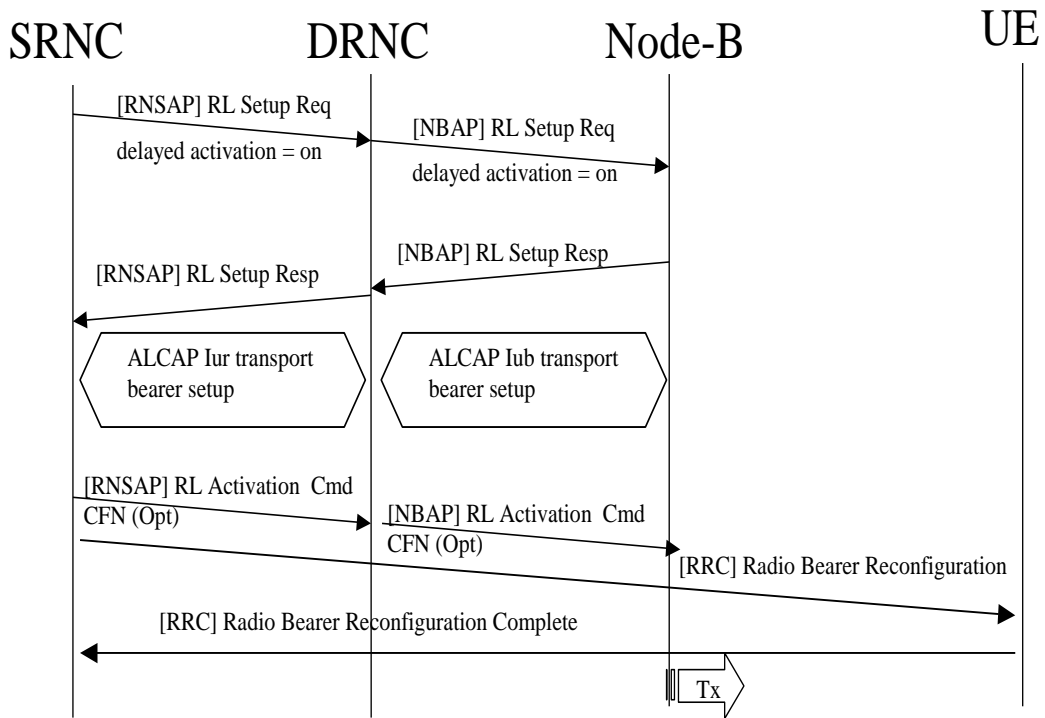

Figure 7: Use of delayed radio link activation

This solution allows to reserve resources in advance and activate them when needed, thus it can also be used as a solution to the problems described in subclauses 6.2 to 6.5.

6.7 Backward compatibility

Backward compatibility shall be ensured by using the correct setting of the criticality. The following settings are proposed in table 9.

Table 9

Effected messages	New IEs	Criticality	Presence	Comment
NBAP RL-Setup-Req NBAP RL-Addition-Req RNSAP RL-Setup-Req RNSAP RL-Addition-Req	- DL TX activation flag - CFN	Ignore and Notify Ignore	O O	Note 1
NBAP DL-Power-Req RNSAP DL-Power-Req	- DL TX activation flag - CFN - Initial DL TX Power - Propagation delay	Ignore Ignore Ignore Ignore	O O O O	Note 2
NOTE 1: If the SRNC/CRNC ever wants to use the DL-Power-Req message to activate/de-activate the DL transmission, it shall include the DL TX activation flag in the RL-Setup/RL-Addition with an appropriate setting. The CRNC/Node-B will inform the SRNC/CRNC about the understanding of this IE due to the criticality setting "Ignore and Notify". For the case in which the IE is understood but the function is not supported, a separate indicator shall be included in the RL-SETUP/ADD-RESP messages.				
NOTE 2: The Initial DL TX Power shall be included when the DL TX activation flag is set to "on" and the UE is not using dedicated channels yet.				
NOTE 3: All new IE's are signalled per RL.				

6.8 Open issues

Void.

7 Agreements

The following conclusions were agreed:

1. In the Release 5 specifications, UE-specific resources reservation will be included.
2. The activation and de-activation of RL's will be performed with a new procedure/message.

8 Specification Impact and associated Change Requests

This clause lists places where Change request need to be given in order to enhance Release 4 specification to Release 5 specification for this work task.

Table 10: Place where Change request is given in order to refer the new procedure

3G TS	CR	Title	Remarks
TS 25.433	602	UTRAN Iub Interface NBAP Signalling	
TS 25.423	563	UTRAN Iur Interface RNSAP Signalling	

Annex A: Change History

Change history							
Date	TSG #	TSG Doc.	CR	Rev	Subject/Comment	Old	New
03/2002	15	-	-		Approved at TSG RAN #15 and placed under Change Control	-	5.0.0