

3GPP TR 25.867 V1.0.0 (2001-11)

Technical Report

**3rd Generation Partnership Project;
Technical Specification Group Radio Access Network;
Technical Report on Feasibility Study for Wideband
Distribution Systems
in 3rd Generation Networks
(Release 5)**



The present document has been developed within the 3rd Generation Partnership Project (3GPP™) and may be further elaborated for the purposes of 3GPP.

The present document has not been subject to any approval process by the 3GPP Organizational Partners and shall not be implemented. This Specification is provided for future development work within 3GPP only. The Organizational Partners accept no liability for any use of this Specification. Specifications and reports for implementation of the 3GPP™ system should be obtained via the 3GPP Organizational Partners' Publications Offices.

Keywords

<keyword[, keyword]>

3GPP

Postal address

3GPP support office address

650 Route des Lucioles - Sophia Antipolis
Valbonne - FRANCE
Tel.: +33 4 92 94 42 00 Fax: +33 4 93 65 47 16

Internet

<http://www.3gpp.org>

Copyright Notification

No part may be reproduced except as authorized by written permission.
The copyright and the foregoing restriction extend to reproduction in all media.

© 2001, 3GPP Organizational Partners (ARIB, CWTS, ETSI, T1, TTA, TTC).
All rights reserved.

Contents

Foreword	5
1 Scope	6
2 References.....	6
3 Definitions, symbols and abbreviations	6
3.1 Definitions	6
3.2 Symbols.....	6
3.3 Abbreviations.....	7
4 Definition of WDS in FDD UTRAN	8
4.1 Introduction	8
4.2 WDS Architecture	8
4.3 Practical Deployment Examples of WDS	9
4.3.1 In-building Deployment.....	10
4.3.2 Outdoor Deployment for Small Cells.....	11
4.4 Benefits of WDS.....	12
4.4.1 Technical and Deployment Aspects.....	12
4.4.2 Standardisation Aspects.....	12
5 RF Feasibility Study	13
5.1 RF Performance Discussion.....	13
5.2 Simulation Program and Assumptions	13
5.3 Definition of RF Power Levels	13
5.4 RF Simulation Parameters	14
5.5 Simulation Results.....	15
5.5.1 ACLR Testing.....	15
5.5.1.1 WDS Output Power 20dBm.....	15
5.5.1.2 WDS Output Power 33dBm	18
5.5.1.3 WDS Output Power 43dBm	20
5.5.2 Multicarrier ACLR.....	22
5.5.3 Measurement of Occupied Bandwidth	23
5.5.4 Spectrum Emission Mask (Out of Band Emissions).....	23
5.6 Simulation Summary	24
5.6.1 ACLR	24
5.6.2 Occupied Bandwidth / Out of Band Emissions	24
5.6.3 Conclusions.....	24
6 Network Performance Evaluation	25
6.1 End to End System Simulations	25
6.2 Simulation Scenarios and Parameters	25
6.3 Simulation Results.....	25
6.4 Network Performance Simulation Summary	25
7 Operation & Maintenance.....	26
7.1 WDS O&M interface	26
7.2 WDS O&M architecture.....	26
7.3 WDS O&M activity plan.....	26
8 Location Services (LCS).....	27
8.1 OTDOA/IPDL.....	27
8.2 Cell ID Method.....	27
8.3 Network Assisted GPS	27
8.4 Summary of WDS impact on LCS	27
9 WDS Positioning on Existing 3GPP TS and WI.....	28
9.1 WDS positioning discussion.....	28
9.2 Potential Impact of WDS Standardisation	28

10 Conclusions and Way Forward.....28

Annex <A>: History of the proposal29

Change history.....30

Foreword

This Technical Report has been produced by the 3rd Generation Partnership Project (3GPP).

The contents of the present document are subject to continuing work within the TSG and may change following formal TSG approval. Should the TSG modify the contents of the present document, it will be re-released by the TSG with an identifying change of release date and an increase in version number as follows:

Version x.y.z

where:

- x the first digit:
 - 1 presented to TSG for information;
 - 2 presented to TSG for approval;
 - 3 or greater indicates TSG approved document under change control.
 - y the second digit is incremented for all changes of substance, i.e. technical enhancements, corrections, updates, etc.
 - z the third digit is incremented when editorial only changes have been incorporated in the document.
-

1 Scope

The present document summarises the results of the feasibility study about inclusion of Wideband Distribution Systems, or WDS, as part of third generation networks in 3GPP standards.

It covers the history of the proposal, shows and discusses the results of relevant analysis and simulation activities, highlights the possible degree of integration to the current status of 3GPP network architecture and concludes with the indication for a possible way forward in the standardisation path.

2 References

The following documents contain provisions, which, through reference in this text, constitute provisions of the present document.

- References are either specific (identified by date of publication, edition number, version number, etc.) or non-specific.
- For a specific reference, subsequent revisions do not apply.
- For a non-specific reference, the latest version applies. In the case of a reference to a 3GPP document (including a GSM document), a non-specific reference implicitly refers to the latest version of that document *in the same Release as the present document*.

- [1] End to End Simulations Detail, TEK 3GPP ETE SD v.0.1, R4-011578 (RAN WG4 #20).
 - [2] “Universal Mobile Telecommunications System (UMTS); UE Radio Transmission and Reception (FDD) (3GPP TS 25.101 version 4.1.0 Release 4)”, Ref. RTS/TSGR-0425101Uv4R1, July 2001
 - [3] “Universal Mobile Telecommunications System (UMTS); UTRA (BS) FDD; Radio transmission and Reception (3GPP TS 25.104 version 4.1.0 Release 4)”, Ref. RTS/TSGR-0425104Uv4R1, July 2001
 - [4] ADS simulation model parameters TEK 3GPP 21_ADS, R4-011579 (RAN WG4 #20)
 - [5] Technical justification and overall advantages for UTRA Wideband Distribution Subsystems (WDS) R4-010668 (RAN WG4 #17).
 - [6] Comments on WDS O&M impact from RAN3 and SA5, R4-011609 (RAN WG4 #20)
-

3 Definitions, symbols and abbreviations

3.1 Definitions

3.2 Symbols

3.3 Abbreviations

For the purposes of the present document, the following abbreviations apply:

3GPP	Third Generation Partnership Project
ACLR	Adjacent Channel Leakage Ratio
ACS	Adjacent Channel Sensitivity
ALC	Automatic Level Control
BS	Base Stations
CPICH	Common Pilot CHannel
DL	Downlink
FDD	Frequency Division Duplex
GPS	Global Positioning System
ID	Identification
IPDL	Idle Period for Down Link
Iub	Interface between RNC and BS
LCS	Location Services
LLI	Low Level Interface
LMU	Local Measurement Unit
LNA	Low Noise Amplifier
MCPA	Multi Carrier Power Amplifier
O&M	Operation and Maintenance
QoS	Quality of Service
OTDOA	Observed Time Difference of Arrival
PCF	Position Calculation Function
RF	Radio Frequency
RNC	Radio Network Controller
TDD	Time Division Duplex
TR	Technical Report
UE	User Equipment
UDD	Unconstrained Delay Data bearer service
UL	Uplink
UMTS	Universal Mobile Telecommunication System
UTRAN	UMTS Terrestrial Radio Access Network
WCDMA	Wideband Code Division Multiple Access
WDS	Wideband Distribution System
WI	Work Item

4 Definition of WDS in FDD UTRAN

4.1 Introduction

UTRAN FDD Base Stations can sometime include Ancillary Equipment like masthead amplifiers or remote radio heads, that may add flexibility and reduce cost of installation.

These solutions are embedded in BS as ancillary RF amplifiers and are therefore seen as integral part of it in a single-vendor deployment scenario.

In order to improve flexibility of radio access network solution, a new type of equipment is proposed, here called Wideband Distribution System, or WDS.

WDS are altogether similar devices, capable of remotisation of BS RF interface, but offering flexible and multiple RF interface to one or more BS or sub-equipped BS. The so-defined WDS shall include one or multiple RF front-ends, RF transmission, and interfaces capable of supporting one or multiple BS.

WDS may be designed to operate in any full UTRA FDD paired or TDD bands according to regional requirements.

Similar definitions are possible in TDD scenarios and may be considered as part of further work, and analysis of the TS 25.105 UTRA (BS) TDD specification has not highlighted any parameters that suggest WDS would not comply in a TDD environment.

The degree of performance impact shall be assessed in this document to understand the effect on multi-carrier WCDMA signals in order to maintain compliance to the relevant standard in the coverage area. The test and simulation scenarios in this report are made with the assumption that of no impact from any passive distribution system. Therefore the results are of an ideal nature and may need to be adjusted to suit the class of base station utilised for deployment.

4.2 WDS Architecture

The key attribute of WDS is its capability to enable the radio interface of a number of BS to be remote, and hence support a distributed multi-carrier and multi-operator network.

WDS is in general an active device and includes, but is not limited to, one or multiple RF front-end (LNA, MCPA) and RF transmission interfaces capable of supporting one or multiple BS. Other ancillary functions may be included as required for best system integration. It also includes O&M facilities and interfaces in order to fulfil any supervision requirements.

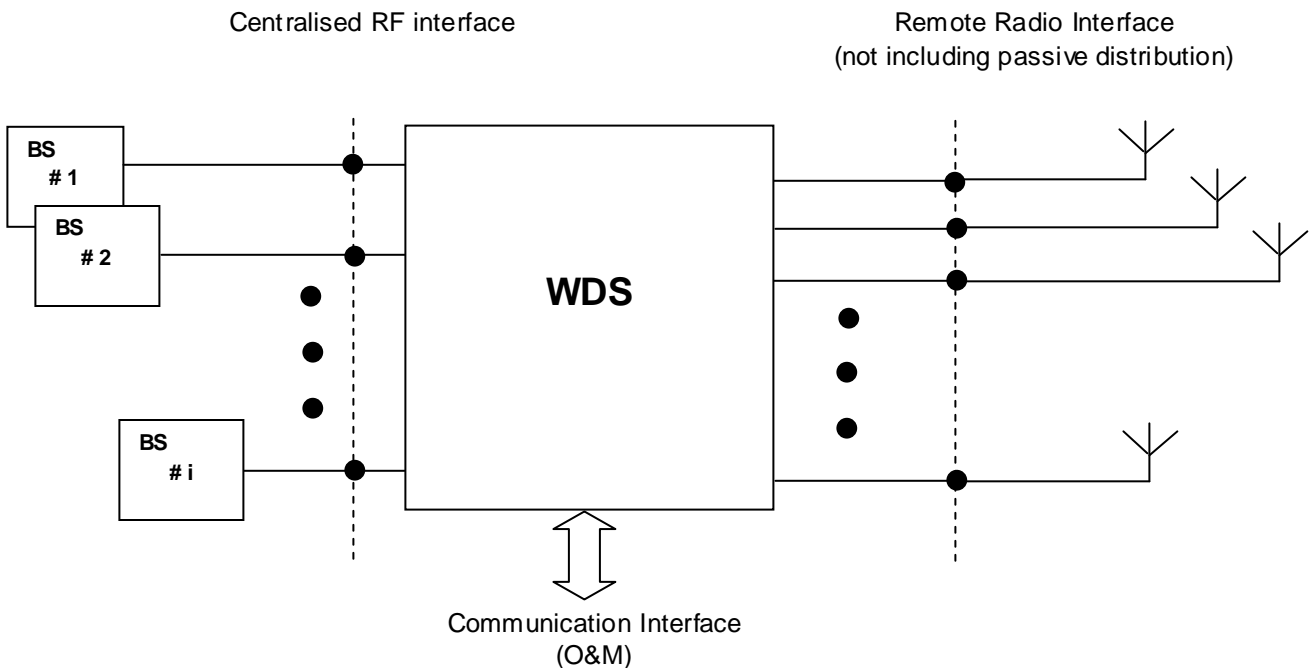

Figure 1 Network Configuration with WDS

WDS generally include a number of functions that are required for correct operation. Those functions are listed and described in Table 1 here below:

Function Definition	Function Description
Centralised multi-operator RF interface	It provides RF independent interface to multiple BS belonging to different networks. It must include provisions such as RF isolation (>30dB), power threshold detectors, and ALC to prevent that any malfunctioning at one network may affect other networks. Transmit RF power at BS interface can be as low as a fraction of a Watt
Transmission	It provides the proper wideband link to a number of remotely placed sites that host suitable RF amplifiers and other devices (RF front-end)
RF transmit M CPA	It amplifies all available RF channels in the downlink direction, and therefore shall offer suitable in a multi-carrier scenario. Power classes can be defined on a wide range, and amplifier technology shall accordingly change to maintain best efficiency
RF receive LNA	It amplifies uplink signals before they are fed back to BS receivers. Its dimensioning is basic in order to optimise uplink dynamic range (NF, Intermods, Blocking)
RF filtering/diplexing	It provides a common TX/RX antenna connector at the remote site, and includes proper selectivity for achieving interference protection as required in the various deployment scenarios
Other functions	Other functions shall be included if applicable, e.g. diversity and O&M

Table 1 – WDS functions breakdown

4.3 Practical Deployment Examples of WDS

Two examples are given only for information and topology understanding purposes of practical deployment for WDS, with reference to previous functions listing in Table 1. Additional indications will require further study on a dedicated Technical Report on WDS Deployment Scenario.

4.3.1 In-building Deployment

A standard layout is shown, where 2 centralised BS belonging to 2 different networks feed a WDS with 24 Remote Low Power RF Heads, with all RF channels distributed throughout the building (or part of it) in one single cell. The case could be easily expanded to a higher number of networks without affecting the concept.

In this deployment case coverage antennas are often fed by means of a small passive distribution network, i.e. 5 to 20 metres coaxial cable and RF splitters/couplers, for maximum losses in the range of 10dB at UMTS frequencies. This loss adds up to the RF path loss. The number N of Remote Heads being conveyed on a single sector would increase UL NF by $10 \log N$, and this will require further consideration in possible WDS specification and deployment scenarios.

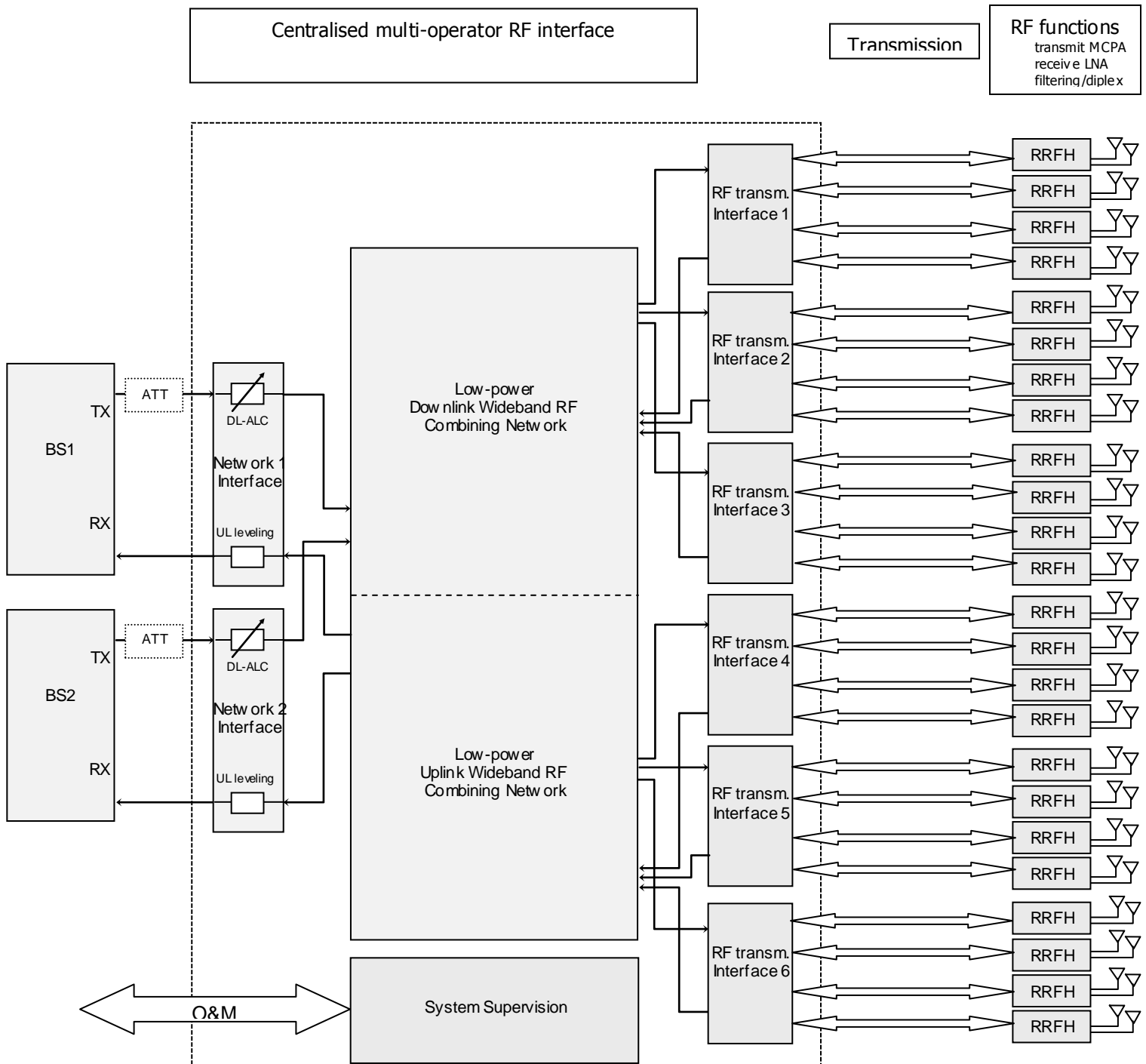

4.3.2 Outdoor Deployment for Small Cells

A possible layout is shown, where 2 centralised BS feed a WDS with 1 Remote RF Head, with dedicated RF channels to each of the small outdoor cells that may be possible with WDS. The case could be easily expanded to a higher number of networks without affecting the concept.

In this deployment case receive diversity path has been added. Hence uplink time delay and RF gain inequality control must be considered as a possible requirement.

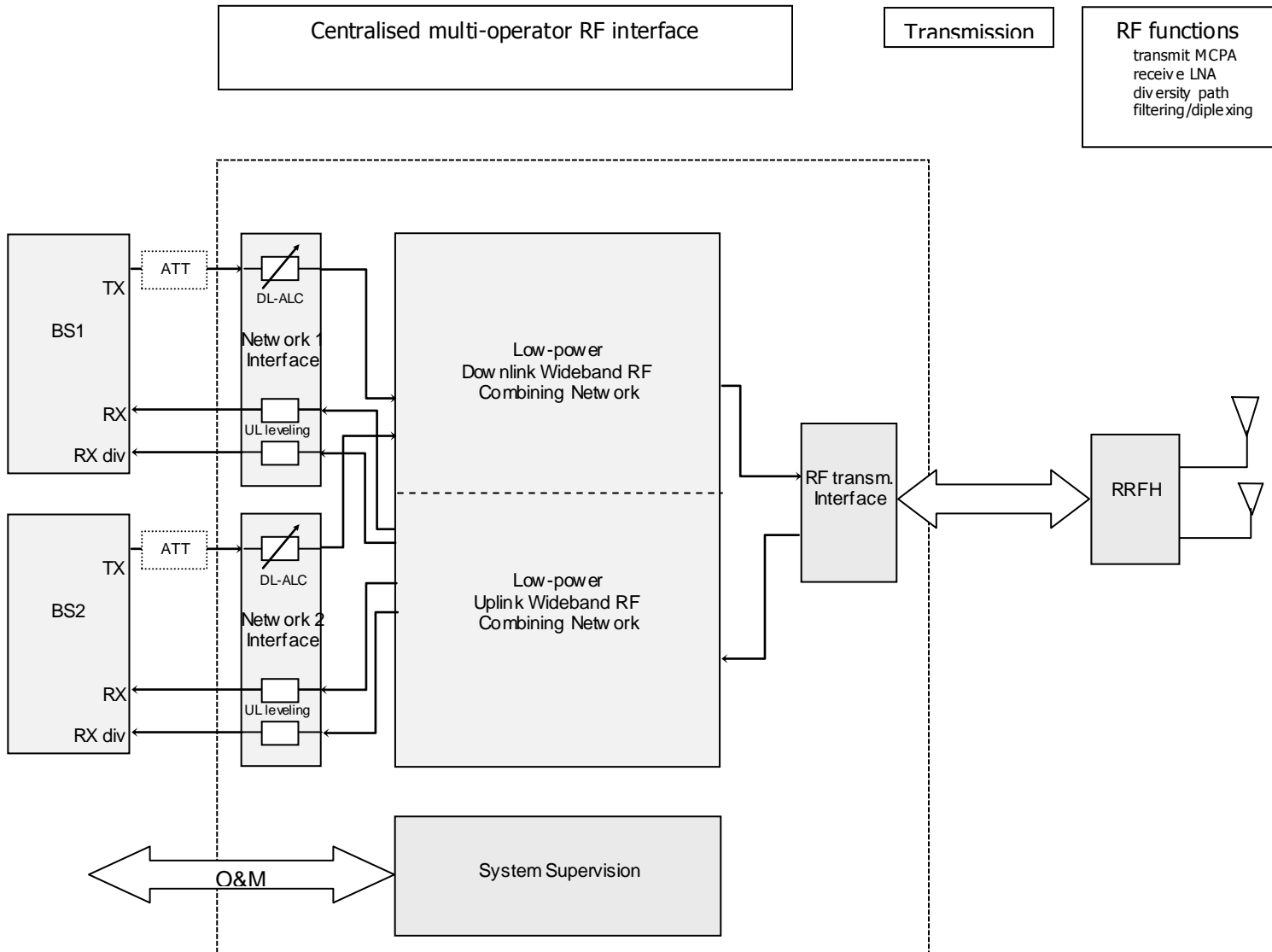

4.4 Benefits of WDS

4.4.1 Technical and Deployment Aspects

Because of its very principle, WDS may bring technical and economical advantages as summarised here:

1. Possible BS and RNC co-location in centralised equipment locations allowing shared facilities, increased implementation flexibility and trunking efficiency.
2. Distributed RF wideband microcellular heads, with lower RF transmission power to cope with most stringent environmental compatibility and scalable traffic capacity requirements.
3. Better and easier flexibility in network planning and upgrading, and on capacity and location systems implementation
4. Sharing opportunities, leading to cost reduction and reduced visual impact for cell sites with the added possibility of increased protection from co-channel and adjacent channel (intra-networks) interference
5. Faster and easier network rollout and maintenance in currently established transmission infrastructures
6. Enabling network manufacturers to shipping base stations and other network elements more quickly

4.4.2 Standardisation Aspects

A standardisation process of WDS in the UMTS UTRA scenario is envisaged for:

1. Removing technical uncertainty risks from Operators and prevent from integration surprises
2. Reducing the burden of additional responsibility for Operators in defining their own specifications for WDS
3. Enabling fulfilment of EU recommendations on network sharing in specific scenarios by providing a common radio distribution solution

5 RF Feasibility Study

5.1 RF Performance Discussion

Starting from reference [5], the RF feasibility study addresses the technical analysis of WDS performance based on its non-linear characteristics that may affect RF transmission through it, and derived as a function of a set of RF parameters at its interface with BS.

The following tables, extracted from the reference, may be useful to highlight why downlink behaviour is more critical than uplink, as this is the primary justification for the simulation work that has been carried out.

	BS on TS 25.104	WDS	Repeater on TS 25.106
Transmit path (DL)	116dB	127dB	109dB
	Measured as distance in dB between output power and background noise in 1Hz bandwidth for comparable output power levels in the three cases: Po_Node B = 31dBm Po_WDS = 32dBm Po_Rpt = 30dBm		
Receive path (UL)	129dB	143dB	91dB
	Measured as distance in dB between input noise level in 1 Hz bandwidth and blocking level – BS, WDS and Repeaters are assumed with NF= 5dB		

Table 2 - Dynamic Range Comparison

BS interface	WDS transmission	WDS RF Head
<<1 microSec	5 microSec/Km*	<<1microSec

Note *: length of physical transmission medium, velocity factor = 0.65

Table 3 - WDS Incremental Time Delay (worst case)

5.2 Simulation Program and Assumptions

The study is based on simulations carried out on a suitable simulation program that takes into account non-linear parameters of WDS and is capable of simulating an equivalent stimulus for one or more WCDMA Base Stations.

Non Linear parameters of WDS are defined based on currently and realistically available technologies.

5.3 Definition of RF Power Levels

For the scope of simulating overall performance, WDS RF transmit power levels utilised in the simulation were focussed mainly on the higher output power level (43dBm) specified in TS25.104. Some tests were carried out at the lower power levels of 20dBm and 33dBm in order to give an indication of likely performance with the yet undefined lower power BS classes.

5.4 RF Simulation Parameters

The simulation programme was focussed on the downlink parameters which were highlighted as the primary concern for system feasibility. ACLR was identified as the main area of focus, in the single and multi-carrier scenario. Other parameters of interest included Spectrum Emissions (Out of Band) and Measurement of Occupied Bandwidth.

In order to carry out initial simulations and attain RF parameters, a realistic WDS system model (Test model 1) was created for single carrier scenarios. The model assumed connection to a compliant BS as supplied in the software package. The model utilised for initial ACLR testing with output power of 20dBm and 33dBm is shown in Figure 2 below.

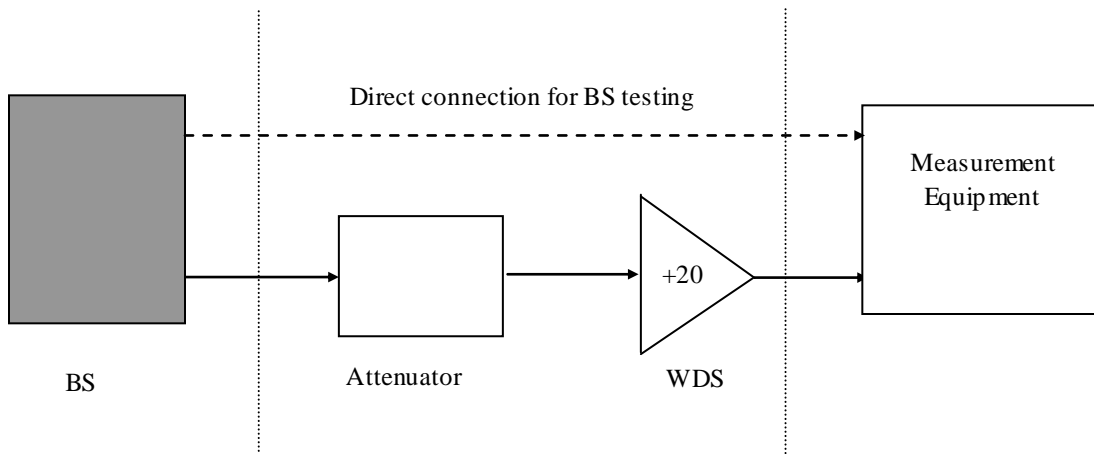

Figure 2 Test model 1 of the WDS

A more complex model (Test Model 2) was then created in order to individually model the non-linearities of each component and reflect values found from actual measurements on real world devices. The model block is shown below in Figure 3.

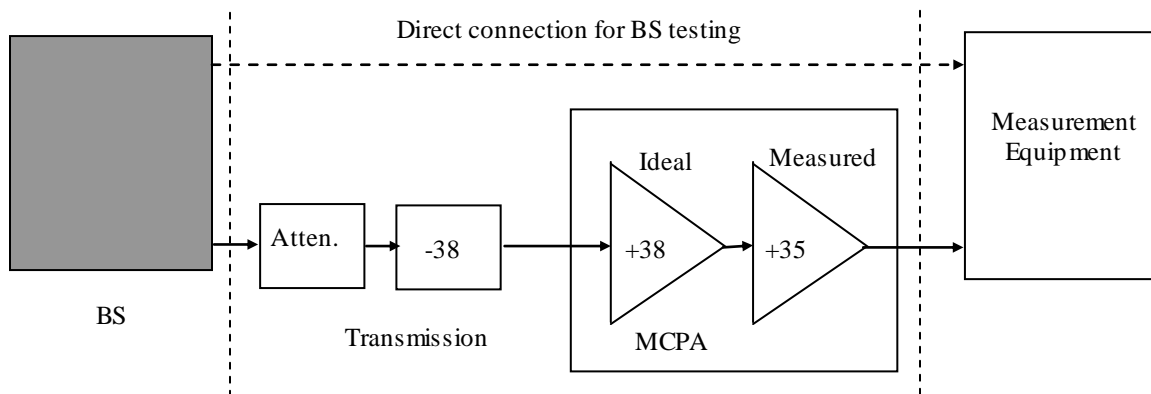

Figure 3 Test model 2 of the WDS

Greater detail of the test model parameters are available in reference [4].

5.5 Simulation Results

5.5.1 ACLR Testing

The simulations are carried out over a range of ACLR levels in order to assess the degradation attributable to the inclusion of a WDS and to attain the minimum ACLR input values to achieve the current specified output levels according to TS 25.104.

The performance of the BS was adjusted in order to achieve the range of ACLR figures around the specification levels. This enabled the ACLR figures to be varied whilst the output power remained constant.

Simulations were first taken without connecting WDS in order to attain the Input ACLR, and then repeated with WDS connected in order to attain the Output ACLR figures.

5.5.1.1 WDS Output Power 20dBm

The BS model was set with a constant gain of 20dB, whilst attenuation of 25.36dB was inserted in order to attain an input level of -2dBm to the WDS, thus achieving a system output power of 20dBm. Test Model 1 was used for this simulation.

Graphs 4 – 7 show the results found.

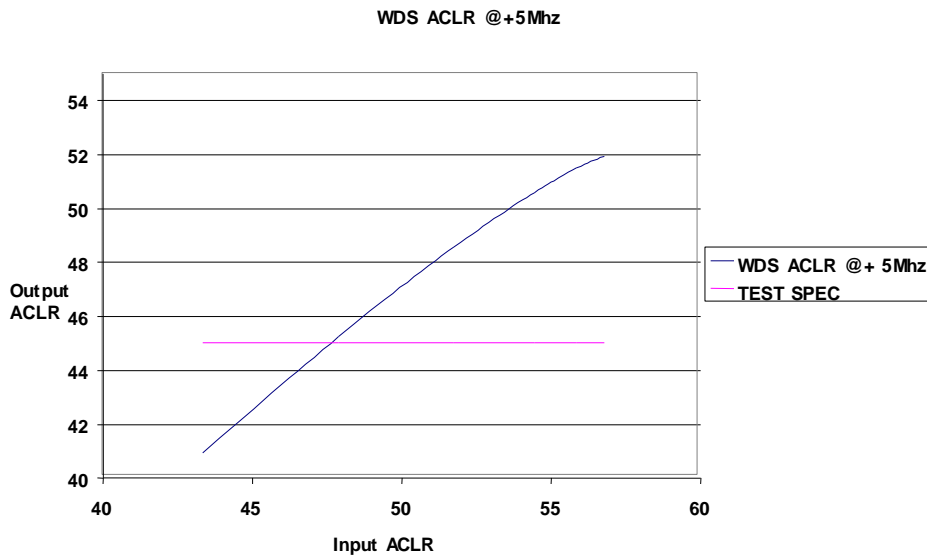

Figure 4

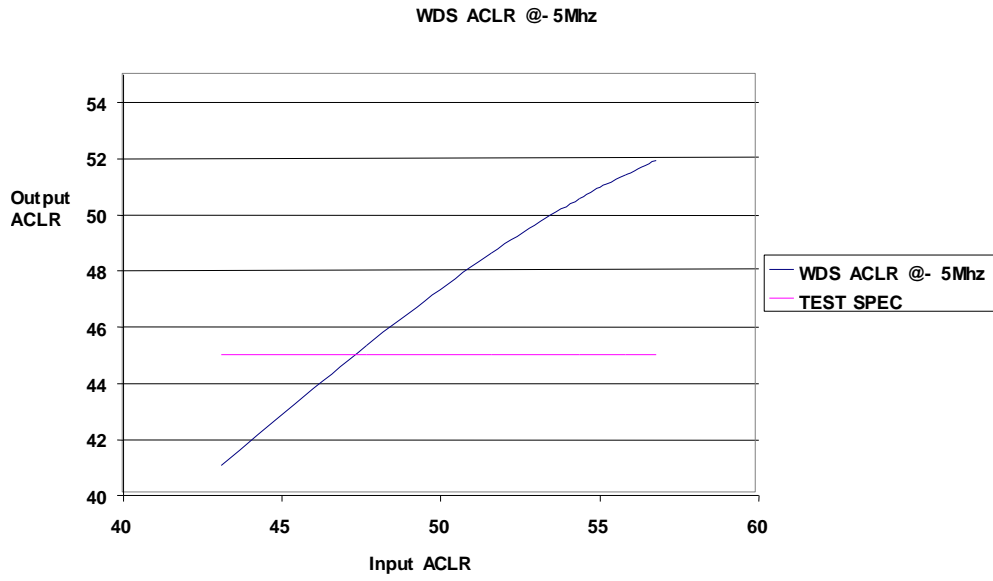

Figure 5

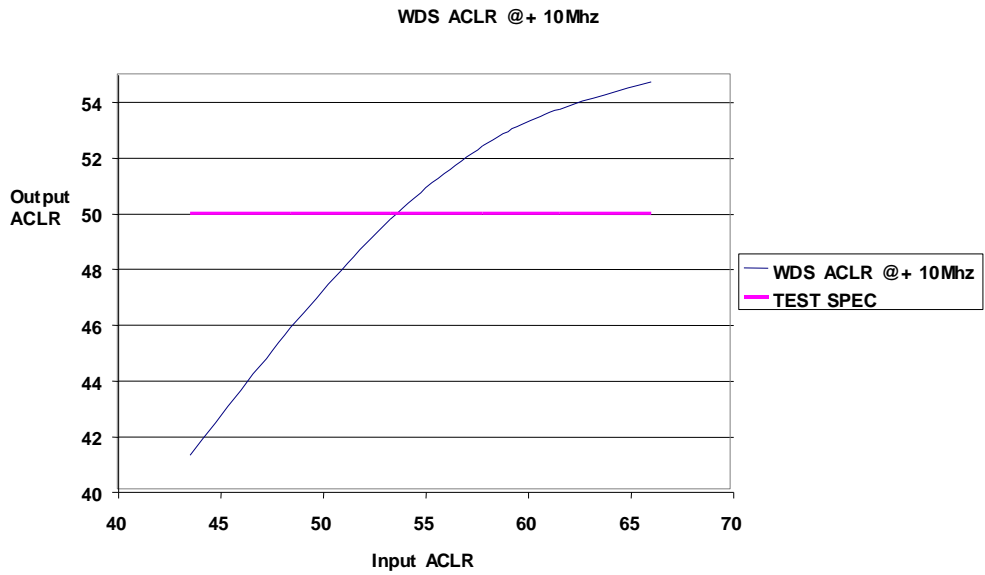

Figure 6

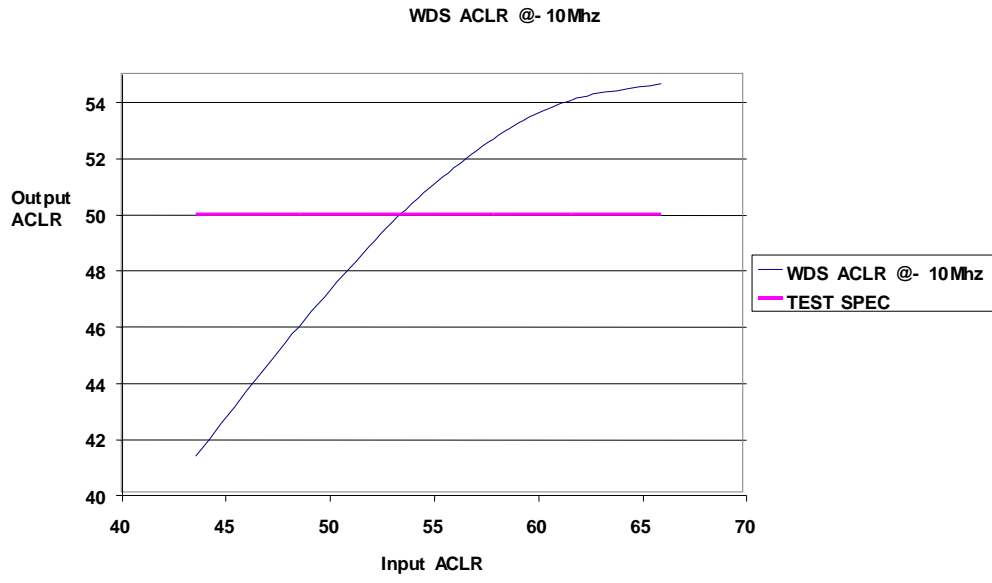

Figure 7

5.5.1.2 WDS Output Power 33dBm

The BS model was set with a constant gain of 20dB, whilst attenuation was decreased to 12dB in order to increase the input level to the WDS to 11dBm, thus achieving system output power of 33dBm. Graphs 8 – 11 show the results found.

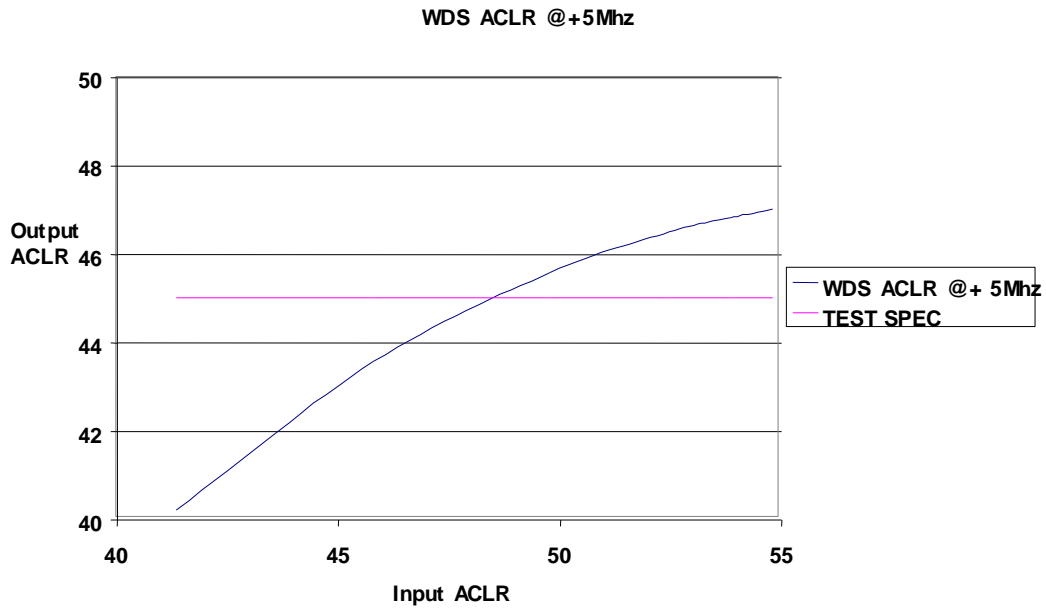

Figure 8

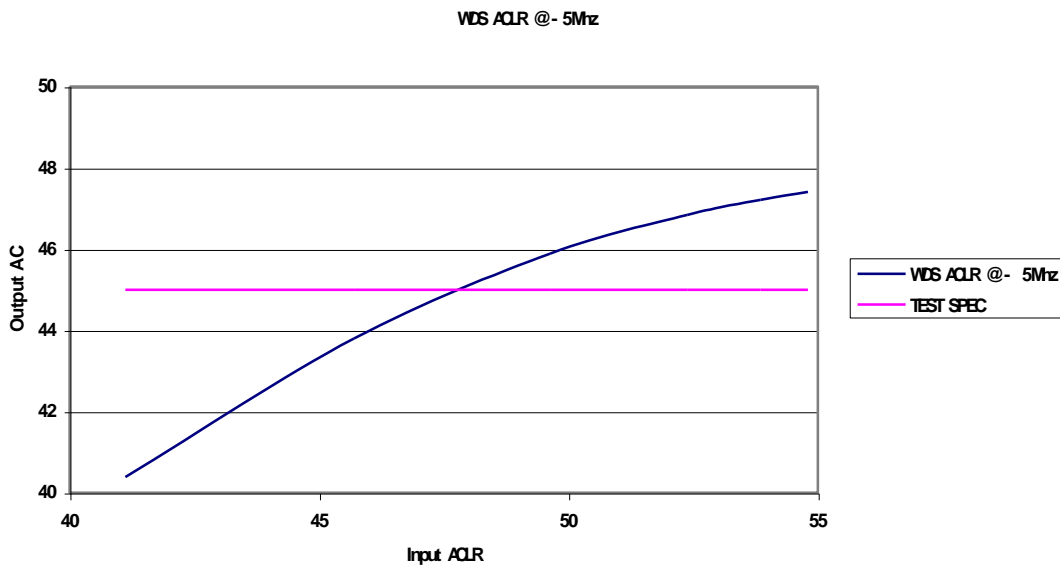

Figure 9

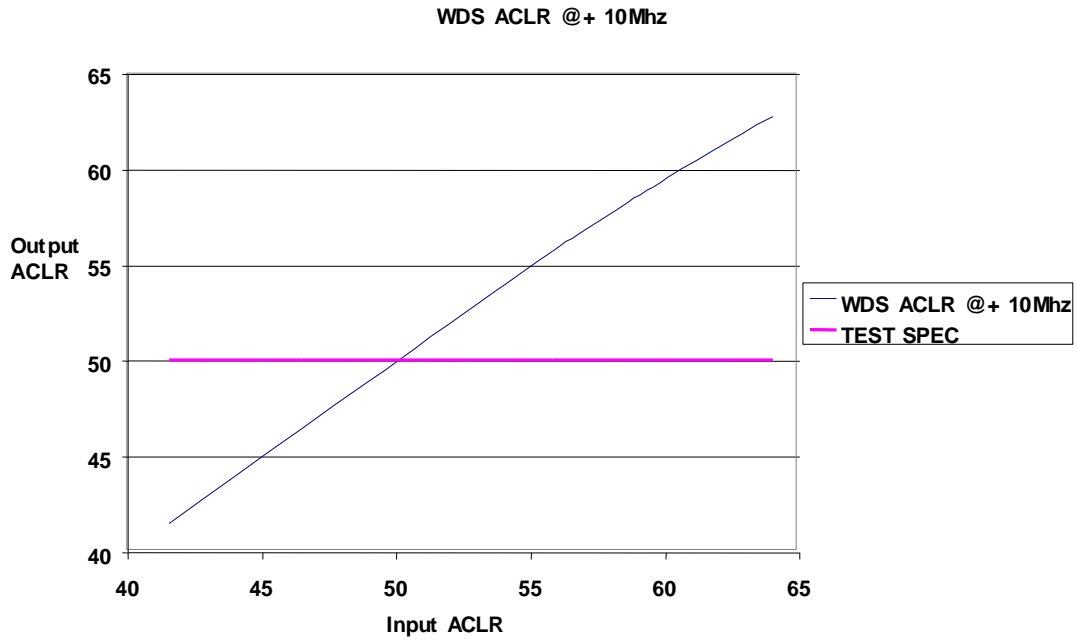

Figure 10

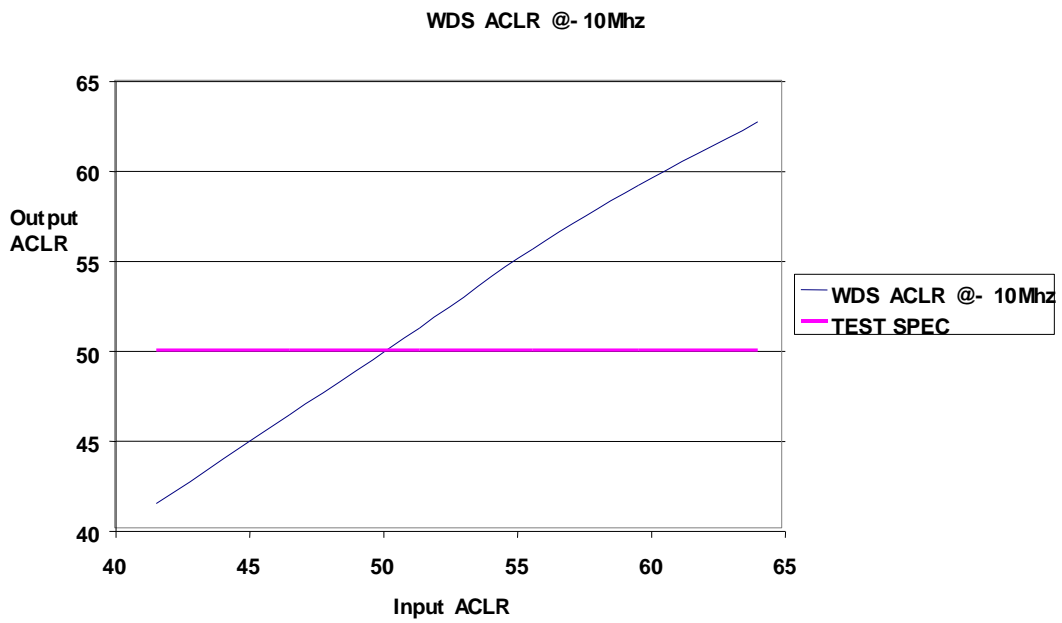

Figure 11

5.5.1.3 WDS Output Power 43dBm

Test Model 2 was utilised for this scenario, with different parameters related to a higher power WDS. Input ACLR was varied by means of adjustment of the performance of the BS in the same manner as in the previous set-up. The results found are shown in figures 12 – 15 below.

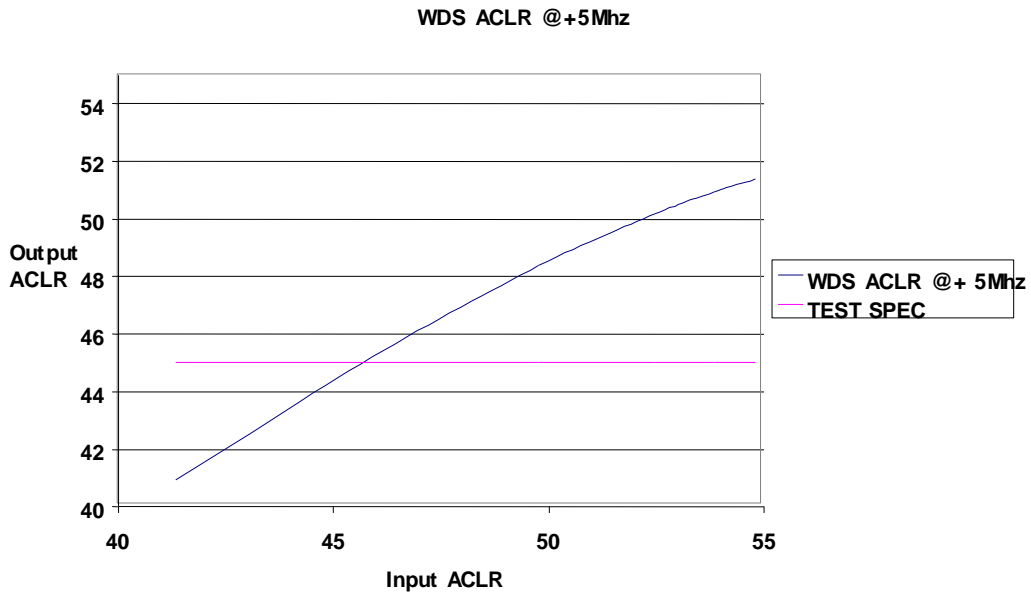

Figure 12

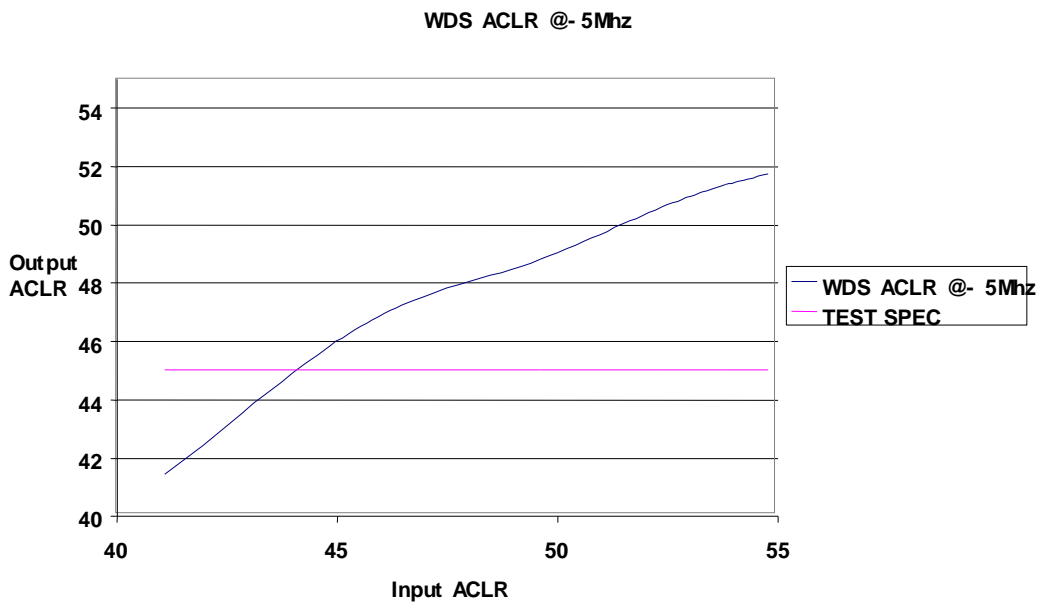

Figure 13

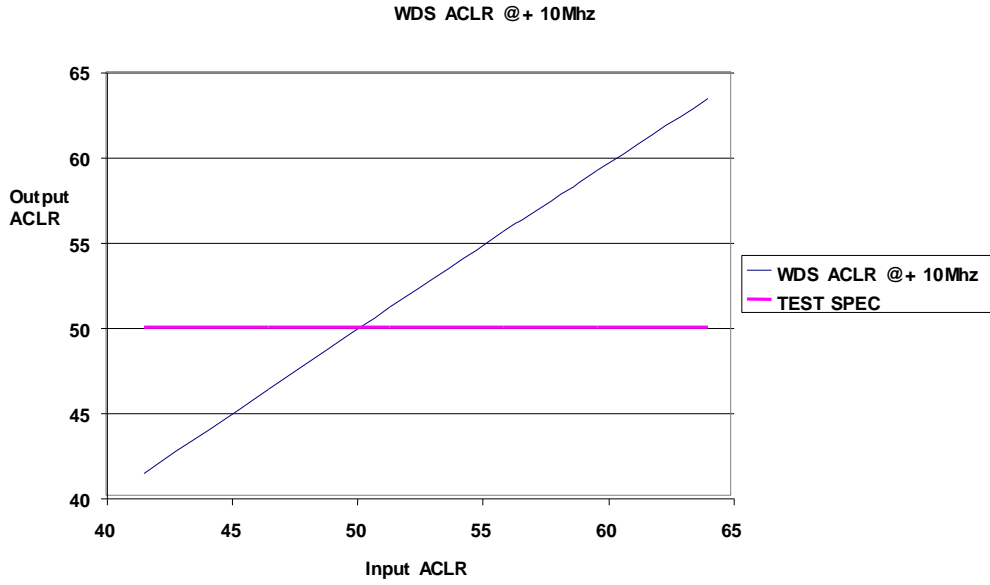

Figure 14

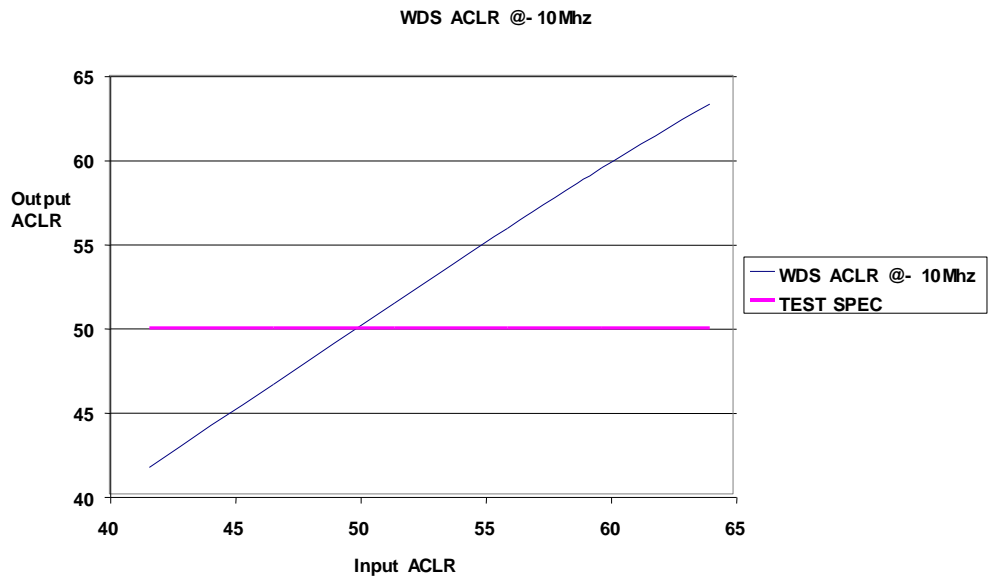

Figure 15

5.5.2 Multicarrier ACLR

In order to assess the impact of a multi-operator environment where multiple BS's were connected to WDS, a test simulation was carried out with two BS, transmitting on adjacent carrier frequencies, connected to WDS Test Model 2 and the ACLR was measured. The test setup is shown in Figure 16 below.

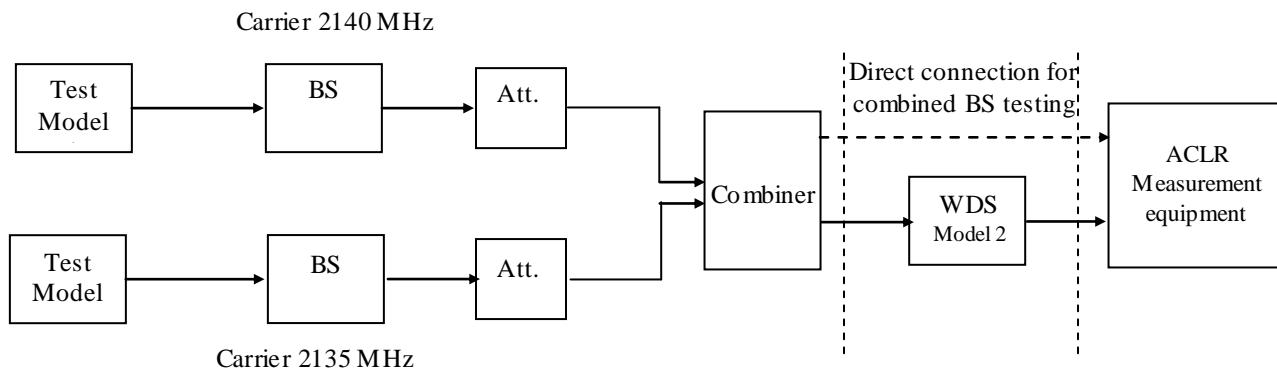

Figure 16 Test setup for multi-operator ACLR.

The gain of the test set-up shown resulted in output power of 23dBm per channel.

The ACLR figures shown below were measured as specified in TS 25.141 for multi-carrier tests. The first test utilises the test bed shown in figure 16 with dotted direct connection. The measurement gives therefore an indication of a multicarrier scenario without the added performance impact which WDS introduces.

Test 2 (as shown in figure 16) was the same in all ways to Test 1 but with the WDS Test Model 2 included in order to record the performance impact. Only two measurement points were simulated due to extremely long simulation runs. The results are shown in table 4 below.

ACLR offset	+10 MHz		+5MHz		-5MHz		-10MHz	
	A	B	A	B	A	B	A	B
BS Direct connection	64.24	53.40	54.81	45.72	54.80	45.91	64.42	54.01
With WDS	64.09	50.05	54.54	43.13	54.43	43.80	64.07	50.10

Table 4 Results for multicarrier ACLR

The BS output ACLR in the example [columns A] is that of a very high quality signal and it can be seen that the impact of WDS on this signal is minimal, whilst [columns B] reflect a TS 25.104 compliant BS and the impact of WDS is clearly visible. Simulation results show that the WDS ACLR in the multi-carrier scenario is similar to the single-carrier scenario.

5.5.3 Measurement of Occupied Bandwidth

WDS test model 2 was used to measure the occupied bandwidth resulting from the inclusion of the WDS. The occupied bandwidth containing 99.5% of the integrated transmitted power (43dBm) was measured at 3.855MHz (see figure 17).

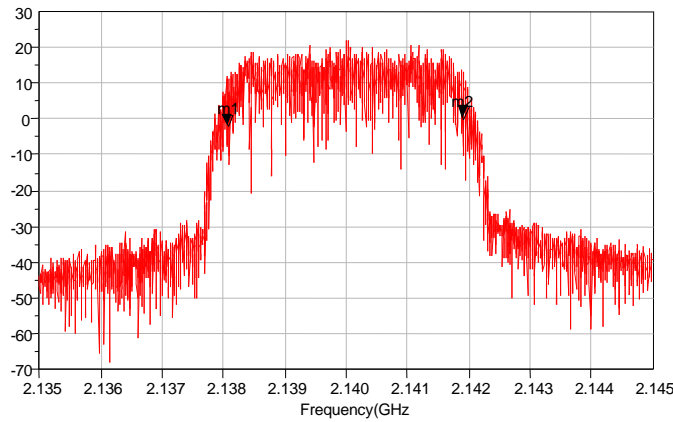

Figure 17 Measurement of the occupied bandwidth.

Results from Figure 17.

Lower Side %	Upper Side %	Occupied Bandwidth (MHz)	Total Power (dBm)
0.242	0.241	3.855	43.237

5.5.4 Spectrum Emission Mask (Out of Band Emissions)

The out of band emissions were measured as specified in TS25.141 for a single carrier scenario with output power of 43dBm using WDS model 2.

The result found is shown in the graph below (figure 18) along with the relevant mask for Power Out greater than or equal to 43dBm (reference TS25.141 6.2.5.1)

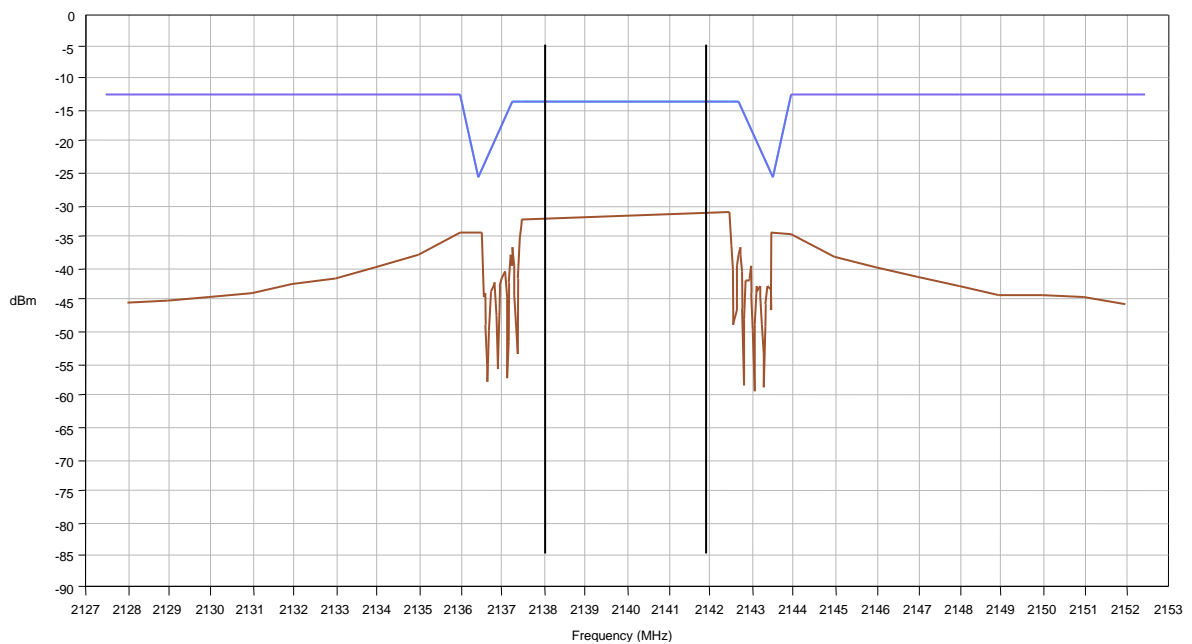

Figure 18 Measurement of the spectrum emission and relevant mask.

5.6 Simulation Summary

The simulation programme and hence the results set out to demonstrate two specific areas of interest.

1. The range of input levels available to a system which would feed a WDS system and its relationship to current specifications.
2. The margin required with the introduction of WDS over a number of output power classes.

5.6.1 ACLR

It was found that a 3dB margin is typically required to accommodate the effects of the inclusion of a WDS to an existing Base Station set-up.

There is a minor difference in performance which is dependent on WDS input signal level. With low input power signal levels, as demonstrated in the example with 20dBm output power, the ACLR at +/- 10MHz becomes “non-linear” at high ACLR input levels. This effect is due to the closer proximity of the input signal level to the noise floor.

A similar effect is evident for higher input power levels although this is found on the +/-5MHz area as the signal levels are subjected to WDS amplifier non-linearity.

Two simulation runs were carried out to understand the impact of multi-carrier operation. The results indicated that for two carriers, each with output power of 23dBm, the impact on ACLR is similar to that seen with a single carrier.

5.6.2 Occupied Bandwidth / Out of Band Emissions

Single carrier testing with WDS output power of 43dBm show that there is negligible impact on the occupied bandwidth or output emissions due to the inclusion of WDS.

5.6.3 Conclusions

The simulations results show the impact of WDS from an RF perspective on most critical downlink parameters, with certain requirements at BS interface point.

Any effects can be measured over a range of different power classes and implementation scenarios in order to define the interface conditions required to satisfy the relevant specification.

Simulations have been limited to downlink parameters because of the utmost importance and higher criticality of this area. Reference [5] and RF performance discussion at 6.1 show that uplink parameters are less critical for WDS, while utilised technologies are of the same kind as for downlink.

ACLR testing has demonstrated that a 3dB margin is desirable to account for WDS inclusion in a system. Further work may be required to verify the recommended margin consistency for the remaining uplink parameters (e.g. Noise Figure, Blocking, and Intermodulation) and downlink parameters (e.g. Modulation Accuracy, Frequency Stability and Accuracy, Output Power Stability and Accuracy) for all scenarios, particularly in the multi-carrier case.

Out of band spurious emissions in any applicable environment are driven by the RF filtering on WDS; this will be designed to suit any of the regional requirements.

6 Network Performance Evaluation

6.1 End to End System Simulations

The potential impact on network performance and QoS connected to the deployment of WDS were assessed by means of end to end system simulations. These simulations are not intended to replace or supersede any other similar simulations that are included in other WG4 works.

Additional information can be found in reference [1], End to End Simulations Detail, TEK 3GPP ETE SD v.0.1, R4-011578].

6.2 Simulation Scenarios and Parameters

The simulations were set out to investigate whether there were impacts to the overall network performance as a result of the inclusion of a WDS.

The network performance was assessed from a comparative perspective, with and without WDS, by performing simulations in a number of scenarios relevant to the key attributes of the WDS system. The main point of focus was the network performance impact when operator site sharing, enabled by WDS, was simulated.

This was explored using a number of different scenarios and a set of parameters as detailed in [1].

6.3 Simulation Results

The details and key findings from the simulation programme are discussed in the mentioned simulation report [1].

All simulations were carried out at pedestrian velocity of 3Km/h with a data rate of 12.2 Kb/s unless otherwise stated.

6.4 Network Performance Simulation Summary

A number of scenarios have been assumed in the simulations in order to assess the implications on the overall QoS that result from the site sharing opportunities offered by WDS.

The simulations have also sought to demonstrate how the WDS can be utilised to enable greater network flexibility in terms of serving different practical scenarios. The findings are summarised in the following points.

1. The presence of two operators with equal offered traffic density and cellular layout (with equal cell radius) doesn't cause a significant loss of quality or of capacity with respect to the single operator case.
2. The presence of WDS, which allows to share sites among operators
 - a. Is not detrimental when the systems are scarcely loaded, while it tends to yield increasing benefits when the offered traffic increases.
 - b. Is more resilient to adjacent carrier interference even when the ACS and ACLR values are substantially reduced (e.g. due to hardware failures or malfunctioning).
3. Deploying micro-cells (made possible by the introduction of WDS) allows increasing system capacity. Traffic density, which leads a system to congestion, may be served by means of an appropriate reduction of cell radius.
4. The maximum DL power can be reduced (to as low as 20 dBm) while offering satisfactory quality, provided that the cell radius is adequately reduced in order to compensate for the decreased coverage.
5. The advantages of site sharing appear more clearly when user bit rates higher than the basic 12.2 Kb/s are considered.
6. The system can accommodate mixed services with satisfactory quality, although when the data services bit rate increases there may be problems with DL quality that can be overcome by adjusting DL power.
7. The analysis of mixed layout systems (composed of both macro-cells and micro-cells) confirms that microcells can carry a traffic density significantly higher than macro-cells in spite of the higher interference they receive from neighbouring macro-cells. In this case, when terminals move faster we observe generally lower blocking and dropping probabilities, at the cost of a higher fraction of unsatisfied users.

8. The analysis of an indoor system with two operators shows that it is possible to carry a 2 Mb/s user for each operator, even in presence of a traffic “floor” due to voice users. When the voice traffic increases it was found that more voice calls are blocked, while the performance for the 2 Mb/s data user remain optimal.

7 Operation & Maintenance

In order to identify any possible impact of a communication interface between WDS and other network elements R3-011933 [Ref. 2] and R5-010481 [Ref. 3] were discussed within RAN 3 and SA5 respectively.

Either working group said that no impact was found on existing specs because of WDS, and it appeared that existing specifications don't prevent possible network configuration including WDS. Detail outcomes are included in following sub-sections.

7.1 WDS O&M interface

The O&M interface for WDS may be required to provide operational status and alarm information to each Network Operator having access to the system, under a network-specific set of parameters, i.e. including:

- General information on common infrastructure available to all networks
- Network specific information (i.e. any interface specific failure alarms)

Transport bearer for O&M implementation may be compliant with TS 25.442, and that in order to re-use existing transport facilities it would share the same physical and data layer of Iub, as Implementation Specific O&M.

7.2 WDS O&M architecture

O&M of WDS may be included as part of "O&M functions for co-located equipment", as its architecture could fulfil the requirement. So-called Interface-N is part of the standard (TS32.101, TS32.102) as the interface towards the systems at the network management level. This means that this interface can be offered either from an element manager or directly from the network elements. Special integration reference points "IRP's" are defined and standardised with different solutions sets (CMIP or CORBA) for alarms and configuration.

One problem with the WDS may be related with independent requirement from network operators.

At least two ways to solve the problem may be identified:

- The WDS system complies with the IRP concept, or it offers e.g. an alarm IRP for fault management; or
- The UMTS Telecom Management Architecture just offers a transparent connection to vendor specific management system for WDS.

7.3 WDS O&M activity plan

Further work is required in order to address all practical issues that may arise from system integration activities. This work will require co-ordination between RAN4, RAN3, and SA5

8 Location Services (LCS)

In order to assess any impact of WDS on location services, the co-existence between WDS and location services (LCS) is discussed in this section. Three methods for location services are currently specified in TS 25.305 – Stage 2 Functional Specification of Location Services in UTRAN. These are OTDOA, Cell ID based positioning and Network Assisted GPS.

8.1 OTDOA/IPDL

The OTDOA/IPDL methods are based on the measurements of the UTRA pilot signal (CPICH) made by the UE and the Location Measurement Unit (LMU). The position of the UE is estimated by using the observed time difference of arrival from three or more base stations.

As measurements are made by the UE who then reports them to the Position Calculation Function (PCF) in the serving RNC, any delays between the remote RF antenna and the serving BS which may be introduced by the WDS are not part of the LCS calculation. In this case the PCF must be aware of the geographical layout of the UTRAN transmitters as configured including WDS.

8.2 Cell ID Method

In the cell ID based method the location of a UE is estimated with the knowledge of its serving BS. The information about the serving BS and cell may be obtained by paging, location area update, cell update, URA update or routing area update.

The result of WDS deployment is that the cells have the potential to become smaller thereby giving greater accuracy compared to a larger cell.

8.3 Network Assisted GPS

These methods make use of UE, which are equipped with radio receivers capable of receiving signals from the Global Positioning System (GPS). Therefore there are no implications to a WDS enhanced network.

8.4 Summary of WDS impact on LCS

From the above discussion it is clear that no impact on LCS is envisaged due to inclusion of WDS

The system calculations required in order to accommodate the provision of LCS information to the network rely primarily on the UE or high level network systems specifically dedicated to LCS.

The only provision for inclusion of WDS will be the requirement that the RNC is aware of the base station architecture including the length of transmission delay in order to make accurate positional calculations.

9 WDS Positioning on Existing 3GPP TS and WI

The present structure of 3GPP UTRAN FDD specifications includes BS (TS 25.104 [ref.1] / TS 25.141 [ref.2]) and Repeaters (TS 25.106 [ref.3]/ TS 25.143 [ref.4]).

TS25.104 relates to Macro BS and its performance. Ongoing work on Base Station Classification WI (TR25.951).

TS25.106 relates to RF Repeater and its performance. The following discussion identifies WDS positioning situation in 3GPP FDD UTRAN TS frame.

9.1 WDS positioning discussion

Following points highlight specific technical positioning for WDS, starting from simulations results.

1. WDS are physically connected to BS according to capacity and coverage planning requirements. They are NOT used to complement radio coverage of a BS (so-called simulcasting), and therefore provide consistent and reliable performance as integral part of the access network, including minimisation of uncertainties in UE location;
2. Because of the tight interface to BS, WDS have low or moderate RF gain. Therefore they don't need complex filtering techniques to provide control of in-band and out-of-band spurious emissions; additionally, WDS allow for controlled and reliable performance in both single- and multi-vendor scenarios, leading to ease of planning; similarly, a reliable alarm and management interface may be provided as discussed;
3. Standard technologies provide WDS instantaneous bandwidth capability to cope with UMTS UTRA FDD full band application, including the various regional requirements;
4. WDS allows BS and RNC to be co-located at centralised equipment locations, where upgrades and implementations can be effected with no requirement to visit remote sites.

The above listed items show WDS ability to supplement and enhance FDD BS capability, and their substantial technical and deployment difference from repeaters. WDS are meant as radio interface remotisers for one or multiple dedicated BS.

9.2 Potential Impact of WDS Standardisation

The Feasibility Study has highlighted the potential impact of WDS standardisation based on existing BS specifications TS25.104/TS25.141, with specific reference to the interface point between BS and WDS, where a more stringent performance than that of compliant BS may be required in order to guarantee full compliance to the standard for the new chain [BS + WDS].

Since Companies did not agree to changing existing specifications because of possible impact in future BS layout, no agreement has been reached at RAN WG4 about such an interface.

The existing and ongoing status of the WI on UTRAN FDD Base Station Classification (TR25.951) offers instead benefits for WDS in certain deployment scenarios and can be related to it.

10 Conclusions and Way Forward

The Feasibility Study has shown how WDS performance may impact on a 25.104 compliant generic BS, on a limited number of basically important parameters and, more in general, in the network configuration.

A new set of compliance parameters should be investigated as a consequence of BS classification and further definition of deployment scenarios.

Further work is required to verify the recommended margin consistency for the remaining uplink parameters (e.g. Noise Figure, Blocking, and Intermodulation) and downlink parameters (e.g. Modulation Accuracy, Frequency Stability and Accuracy, Output Power Stability and Accuracy) for all scenarios, particularly in the multi-carrier case.

Since it was not yet possible to agree on any different requirements for BS specifications, and because of the specific interest for using WDS for small cell applications, it may be recommended to relate any further related work on WDS to the definition of BS classes for given deployment scenarios, and for those RF parameters that may be part of WDS technical nature. The way WDS may be included in 3GPP specs is not clear yet and needs further co-ordination with other ongoing work in related areas (e.g. BS classification and Repeaters).

Annex <A>: History of the proposal

RAN 4 Meeting #17, Gothenburg, Sweden (21-25 May 2001)

Document R4- 010559 Technical justification and overall advantages of WDS

Discussion document explained the concept and the benefits of a WDS. A hardware description and RF performance attributes were discussed in relation to the current TS25.104 specification. It was agreed to proceed with a feasibility study.

RAN Plenary Meeting #12, Stockholm, Sweden (12-15 June 2001)

Document RP-010488 Study Item description sheet for feasibility study on UTRA WDS

Document detailed the justification for the system and set out the criteria which must be satisfied in order to proceed. This included addressing RF performance, end to end system performance and consideration of location service and O&M aspects. Study Item status was given.

RAN 4 Meeting #18, Berlin, Germany (9-13 July 2001)

Document R4-010935 WDS Study Item Status Update

Document presented for information and to raise discussion items to be addressed in final study phase TR. Concerns were raised about impact on system performance due to inclusion of WDS. Difficulties were voiced on setting new requirements on TS25.104 for a low-level interface (LLI) between the BS and the WDS. Therefore clarifications on the concept were required.

RAN 4 Meeting #19, Edinburgh, Scotland (3-7 September 2001)

Document R4-011045 WDS Study Item Report

Feasibility Study results presented for decision which covered the following subjects:

1. End to end system performance improvements shown through major simulation work.
2. RF up-link and downlink parameters for LLI, WDS and compliance to TS25.104 at antenna port.
3. Address all questions raised at previous RAN 4 meetings with detailed explanations of LLI concept, system degradation, LCS and O&M impact.

It was noted by a number of delegates that there were no doubts of the benefits of WDS, specifically in order to provide the ability to share resources in indoor environments.

Further concerns were raised by some delegates over the understanding of LLI, specifically on how it may physically interface with variable BS configurations and about its technical feasibility against existing TS 25.104.

Due to recognised benefits of WDS, it was recommended that the study item phase be continued in order to close out the points raised.

RAN plenary meeting #13, Beijing, China (18-21 September 2001)

Document RP-010638 Status Report for information

Completion date is expected at RP#14 with formal TR. It was commented that the included report was not a formal TR and that no agreement had yet been reached on it in WG4.

RAN 4 Meeting #20, East Brunswick, NJ, USA (12-16 November 2001)

Document R4-011516 Submission of present TR 25.867 v.0.1.0

Change history

Change history							
Date	TSG #	TSG Doc.	CR	Rev	Subject/Comment	Old	New