

# 3GPP TR 25.854 V5.0.0 (2001-12)

---

*Technical Report*

## **3rd Generation Partnership Project; Technical Specification Group Radio Access Network; Study Report for Uplink Synchronous Transmission Scheme (USTS);**

**(Release 5)**



The present document has been developed within the 3<sup>rd</sup> Generation Partnership Project (3GPP™) and may be further elaborated for the purposes of 3GPP.

The present document has not been subject to any approval process by the 3GPP Organizational Partners and shall not be implemented. This Specification is provided for future development work within 3GPP only. The Organizational Partners accept no liability for any use of this Specification. Specifications and reports for implementation of the 3GPP™ system should be obtained via the 3GPP Organizational Partners' Publications Offices.

---



Keywords

---

UMTS, radio

**3GPP**

Postal address

---

3GPP support office address

---

650 Route des Lucioles - Sophia Antipolis  
Valbonne - FRANCE  
Tel.: +33 4 92 94 42 00 Fax: +33 4 93 65 47 16

Internet

---

<http://www.3gpp.org>

---

**Copyright Notification**

---

No part may be reproduced except as authorized by written permission.  
The copyright and the foregoing restriction extend to reproduction in all media.

© 2002, 3GPP Organizational Partners (ARIB, CWTS, ETSI, T1, TTA, TTC).  
All rights reserved.

# Contents

Foreword .....	6
Introduction .....	6
1 Scope .....	7
2 References.....	7
3 Symbols and abbreviations .....	7
3.1 Symbols .....	7
3.2 Abbreviations .....	8
4 Study Area for USTS .....	8
4.1 Timing control (time synchronisation).....	9
4.1.1 The reference time .....	10
4.1.2 Initial synchronization .....	10
4.1.3 Tracking process .....	11
4.1.3.1 Time Alignment Bit (TAB) .....	11
4.1.3.2 Closed loop timing control.....	11
4.1.3.3 Proposed adaptive tracking scheme after Initial synchronization .....	11
4.2 Code usage for USTS (Code synchronisation) .....	11
4.2.1 Scrambling code .....	11
4.2.1.1 UL scrambling code reference point .....	12
4.2.2 Channelisation code allocation .....	14
4.2.2.1 Proposed OVSF code allocation rule for USTS .....	14
4.2.2.2 Channelisation codes for DPDCHs .....	15
4.3 Soft handover in USTS mode .....	15
4.3.1 Handover in USTS mode .....	15
4.3.1.1 Three modes for soft handover in USTS mode .....	15
4.3.1.2 Three procedures for handover in USTS mode .....	16
4.3.2 Four candidates in case of two-way handover.....	16
4.3.2.1 Detailed description on Candidate 3 .....	18
4.3.2.2 Detailed description on Candidate 4 .....	18
4.3.2.3 Arrival timing at Node B's .....	19
5 Performance .....	21
5.1 Simulation parameters .....	21
5.2 Simulation results .....	22
5.3 Capacity gain .....	28
5.4 Eb/No impact of using SF=128 instead of 64 .....	29
5.5 System simulations on USTS gain in Pedestrian A environment.....	30
6 Complexity issue.....	32
6.1 Introduction.....	32
6.2 Timing control complexity .....	32
6.3 Different scrambling/channelisation code usage.....	32
6.4 Soft handover complexity .....	33
6.5 Impact on closed loop power control .....	34
6.6 Rx-Tx timing relation at UE in the USTS mode .....	35
7 Impacts to other WGs.....	35
7.1 WG2.....	35
7.1.1 RRC layer .....	35
7.1.2 RLC Layer .....	35
7.1.3 MAC Layer.....	35
7.1.4 Interface between RRC and PHY layer .....	35
7.2 WG3 .....	36
7.2.1 New parameters .....	36
7.2.2 Impacts on Interfaces .....	38
7.2.2.1 Iub Interface .....	38

7.2.2.2 Iur Interface .....38

7.2.2.3 Iu Interface .....38

7.2.3 Procedures.....38

7.2.3.1 Mode Change procedure .....38

7.2.4 Call flows of USTS .....40

7.2.4.1 Call Setup.....40

7.2.4.2 Channel and Mobile State Change .....42

7.2.4.3 Soft Handover .....44

7.3 WG4 .....46

8 Backward compatibility .....46

**Annex A: Change history .....47**

---

## Foreword

This Technical Report has been produced by the 3<sup>rd</sup> Generation Partnership Project (3GPP).

The contents of the present document are subject to continuing work within the TSG and may change following formal TSG approval. Should the TSG modify the contents of the present document, it will be re-released by the TSG with an identifying change of release date and an increase in version number as follows:

Version x.y.z

where:

- x the first digit:
  - 1 presented to TSG for information;
  - 2 presented to TSG for approval;
  - 3 or greater indicates TSG approved document under change control.
- y the second digit is incremented for all changes of substance, i.e. technical enhancements, corrections, updates, etc.
- z the third digit is incremented when editorial only changes have been incorporated in the document.

---

## Introduction

At RAN#9 plenary meeting, a study report for “Uplink synchronous transmission scheme” was decided to be finished by March 2001. Uplink Synchronous Transmission Scheme (USTS) is an alternative technology applicable for low mobility terminals, especially in indoor and dense pedestrian environments. USTS can reduce uplink intra-cell interference by means of making a cell receive orthogonalized signals from UEs. This feature is intended to support uplink synchronous transmission with low overhead, good capacity characteristics, and minimal impact on hardware and software resources at the UE and in the UTRAN.

---

# 1 Scope

The present document describes the techniques behind the concept of uplink synchronous transmission scheme and how this concept should be integrated into the overall architecture of UTRA. It also deals with the feasibility of USTS, including performance and expected complexity.

---

# 2 References

The following documents contain provisions which, through reference in this text, constitute provisions of the present document.

- References are either specific (identified by date of publication, edition number, version number, etc.) or non-specific.
- For a specific reference, subsequent revisions do not apply.
- For a non-specific reference, the latest version applies. In the case of a reference to a 3GPP document (including a GSM document), a non-specific reference implicitly refers to the latest version of that document *in the same Release as the present document*.

- [1] 3GPP TS25.133: "Requirements for support of radio resource management (FDD)"
- [2] 3GPP TS 25.211: "Physical channels and mapping of transport channels onto physical channels (FDD)"
- [3] 3GPP TS 25.213: "Spreading and modulation (FDD)"
- [4] 3GPP TS 25.214: "FDD : Physical layer procedures "
- [5] 3GPP TS 25.302: "Services provided by the Physical Layer"
- [6] 3GPP TS 25.331: "Radio Resource Control (RRC) Protocol Specification"
- [7] 3GPP TS 25.423: "UTRAN Iur Interface RNSAP Signalling"
- [8] 3GPP TS 25.433: "UTRAN Iub Interface NBAP Signalling"
- [9] 3GPP TS 25.435: "UTRAN interface User Plane Protocol for Common Transport channel Data Streams"
- [10] 3GPP TS 25.306: "UE Radio access capabilities definition"
- [11] 3GPP TR 25.839: "Uplink Synchronous Transmission Scheme (USTS) (Iur/Iub aspects)"

---

# 3 Symbols and abbreviations

## 3.1 Symbols

For the purposes of the present document, the following symbols apply:

$T_{ref}$	Reference time
$T_{INIT\_SYNC}$	Amount of adjustment for initial synchronisation

## 3.2 Abbreviations

For the purposes of the present document, the following abbreviations apply:

CFN	Connection frame number
DPCCH	Dedicated physical control channel
DPDCH	Dedicated physical data channel
RTD	Round trip delay
RTPD	Round trip propagation delay
TAB	Time alignment bit
$T_{ref}$	Reference time
UE	User equipment
USTS	Uplink synchronous transmission scheme
UTRAN	Universal terrestrial radio access network

---

## 4 Study Area for USTS

Note: USTS is optional for both UE and UTRAN.

Figure 4.1 describes DPCH arrival times from UEs in the Node B with and without USTS. Without USTS, the uplink signals from different UEs arrive at different time instants. The beginning point of radio frame in the Node B differs for different UE due to different value of  $\tau_{DPCH}$  and different propagation delay (RTPD: Round Trip Propagation Delay). And accordingly, different scrambling codes are used for different UEs to discriminate them and the interference from other users is determined by the cross-correlation among scrambling codes.

USTS makes the signals orthogonal by sharing a common scrambling code and assigning different channelisation codes to the UEs similarly to the downlink. In order to preserve orthogonality at the receiving side (Node B), the transmission time on the UE side needs to be adjusted so that the arrival times in the Node B becomes  $\tau_{DPCH} + T_0 + T_{ref}$ , where  $T_{ref}$  is the reference time. This is called here **time synchronisation**. In the figure, the cell radius is assumed to be smaller than 10km and accordingly, the amount of timing control is less than +/-128 chips. The transmission timing control needs to be done at call setup phase and during call as well to compensate both the initial propagation difference and the variation due to UE movement. Since the channelisation codes repeat every 256 chips at least and  $\tau_{DPCH}$  is a multiple of 256 chips, the orthogonality among channelisation codes can be maintained when different  $\tau_{DPCH}$  is assigned to different DPCH. After descrambling, only channelisation codes need to remain as in the downlink to get orthogonality. To do so, the generation of the common scrambling code is controlled to be reset at a same reference time for all users. This is called here **code synchronisation**. By eliminating the interference from the first detected paths of other UEs, USTS can improve the uplink performance. Currently, UE has only one transmitter and hence, the transmission timing can be adjusted with respect to only one of the cells in Active set. This means USTS can get a performance gain through suppressing intra-cell interference not inter-cell interference. In indoor and dense pedestrian environments, since most of the signal power is carried along the first resolvable path with a chip rate of 3.84 Mcps, high performance gain can be expected by adopting USTS in these environments. USTS is targeting these environments not only because of its good performance but also because of possible need of high uplink capacity in these environments with imposing small modification onto current specifications.



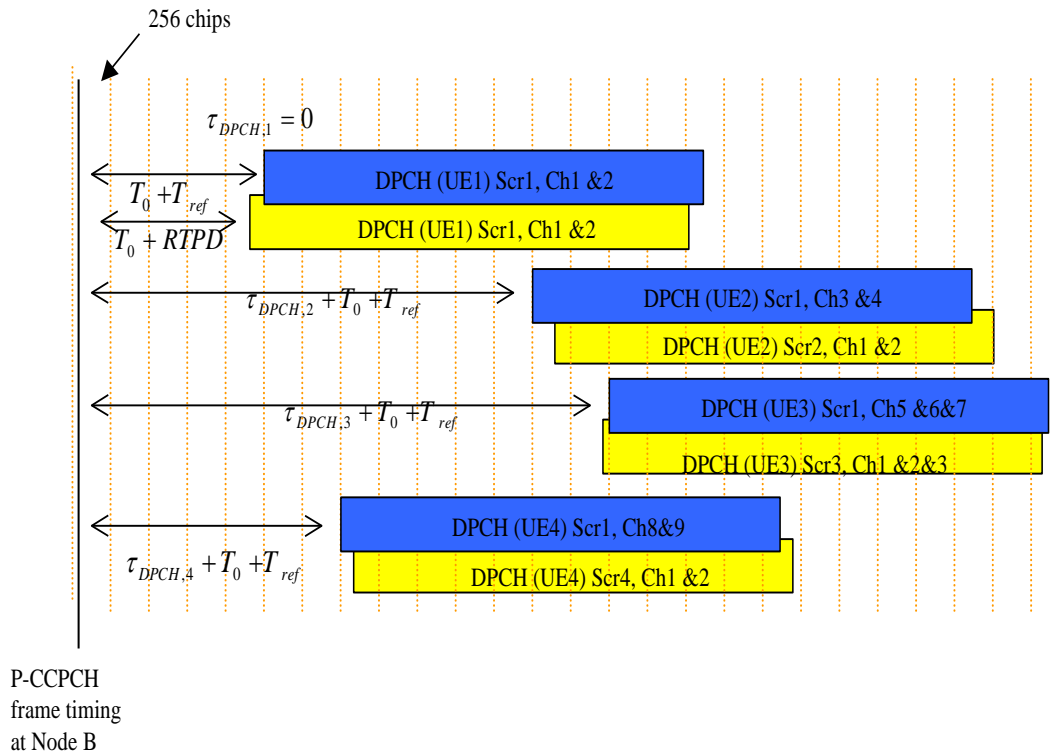

**Figure 4. 1 DPCH arrival times from UEs in the Node B with/without USTS (4 UEs, Yellow: without USTS, Blue: with USTS)**

## 4.1 Timing control (time synchronisation)

In USTS mode, time alignment is required to preserve orthogonality between channelisation codes from different UEs and also to properly despread the cell-specific long scrambling code. The transmission time at UE is adjusted in two steps. The first step is Initial synchronization and the second is tracking process.

- 1) Initial synchronisation: Adjust transmission time according to the initial timing control information given by higher layer through FACH.
- 2) Tracking process (Closed Loop Timing control): Adjust the transmission time according to the Time Alignment Bit (TAB) over DPCCH.

In Figure 4. 2, before adjustment, DPCH message is expected to arrive at point A, where  $\tau_{DPCH,n}$  is a multiple of 256 chips offset and  $T_0$  is constant. After adjustment according to  $T_{INIT\_SYNC}$ , the arrival at Node B is scheduled to occur at point B,  $\tau_{DPCH,n} + T_0 + T_{ref}$  later from the beginning of each P-CCPCH frame in the Node B. There may be variation around point B due to movement of UE and this can be overcome by Tracking process using TAB commands. And accordingly, it keeps the uplink DPCCH/DPDCH frame of a UE arriving at Node B at the same point. In return, the UL/DL relative timing is not fixed but is to vary in the range with a width of  $2\beta$ . The width and the range are closely related to the reference time  $T_{ref}$ . The figure assumes that the  $T_{ref}$  is set to the maximum one-way propagation delay so that the value  $\beta$  comes to  $T_{ref}$ . When the UE is closest to the cell site, the UL/DL relative timing is  $T_0 + T_{ref}$ . On the other hand, if the UE is at the cell boundary, the UL/DL relative timing becomes  $T_0 - T_{ref}$ . Since the UE exists between these two extreme points, the UL/DL relative timing is within the range of  $[T_0 - T_{ref}, T_0 + T_{ref}]$ , i.e., the range is centered at  $T_0$ . If the value  $T_{ref}$  is determined differently, the range is shifted while maintaining the width.

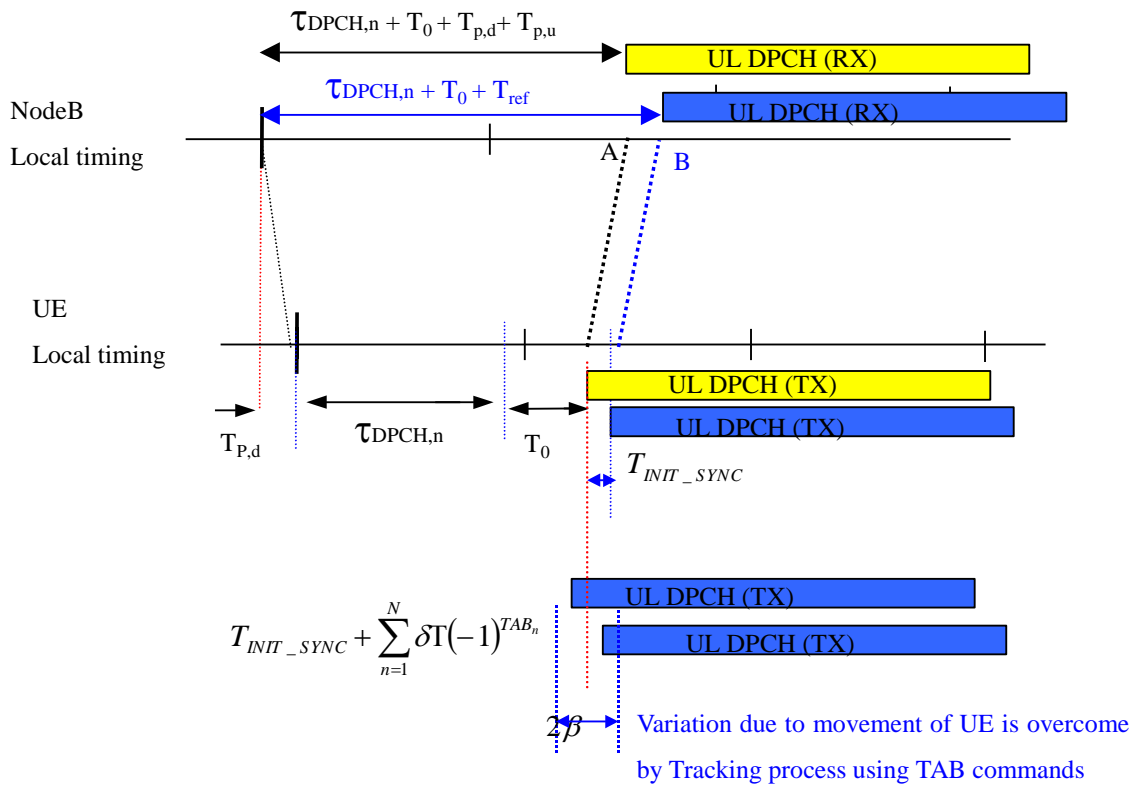

**Figure 4. 2 Initial synchronisation and Tracking process for DPDCH/DPCCH (Yellow: before adjustment, Blue: After adjustment).**

### 4.1.1 The reference time

$T_{ref}$  is given to RNC as initial loading data and the desired arrival time becomes  $\tau_{DPCH,n} + T_0 + T_{ref}$  in the Node B. Since  $\tau_{DPCH,n} = T_n \times 256$  chip,  $T_n \in \{0, 1, \dots, 149\}$ , the desired arrival time may exist every 256 chips according to  $\tau_{DPCH,n}$ . Different UE arrives at the cell at one of the desired arrival times according to  $\tau_{DPCH,n}$  and the orthogonality among channelisation codes can be preserved. The proposed value for  $T_{ref}$  is the maximum one-way propagation delay and for example, it comes to 128 chips for a cell radius of 10 km and a chip rate of 3.84 Mcps.

### 4.1.2 Initial synchronization

First, UTRAN obtains the round trip propagation delay (RTPD) by doubling the value of PRACH Propagation Delay measured in TS 25.215 and sets the amount of adjustment for initial synchronisation  $T_{INIT\_SYNC}$  to compensate the difference between the RTPD and  $T_{ref}$ . UE adjusts its transmission time according to  $T_{INIT\_SYNC}$  delivered from UTRAN through FACH. Since  $T_0$  is a constant (1024 chips) and  $T_{ref}$  is a given value and same for all UEs in a cell, after initial synchronisation, the arrival in the Node B can be controlled to occur within  $[\tau_{DPCH,n} + T_0 + T_{ref} - 1.5chips, \tau_{DPCH,n} + T_0 + T_{ref} + 1.5chips]$  due to 3 chip resolution for reporting PRACH Propagation delay.

## 4.1.3 Tracking process

### 4.1.3.1 Time Alignment Bit (TAB)

In case of USTS, a proper timing control rate needs to be determined by considering the synchronisation performance of timing control and the impact on closed loop power control performance. One proposal is that the TPC bits are replaced by Time Alignment Bits (TABs) every two frames (20 msec timing control interval).

### 4.1.3.2 Closed loop timing control

The proposed procedure is as follows;

- Node B compares the received arrival time with the desired arrival time from UE every 200 msec (according to W4 UE transmit timing assumptions [1]).
- When the received arrival time is earlier than the desired arrival time at a Node B, Time Alignment Bit (TAB) is set to "0". When this is later than the desired arrival time, TAB = "1".
- TAB replaces the TPC bit in slot #14 in frames with CFN mod 2 = 0.
- At the UE, a number of Time Alignment Bits are combined over a 200 ms interval, which increases the reliability of the time alignment process.. When the combined time alignment command is judged as "0", the transmission time shall be delayed by  $\delta T$ , whereas if it is judged as "1", the transmission time shall be advanced by  $\delta T$ .  $\delta T$  is the timing control step size, whose minimum value depends on the oversampling rate.

### 4.1.3.3 Proposed adaptive tracking scheme after Initial synchronization

<The step size in this section is just a proposal. The step size in normal tracking process is denoted as  $\delta T$  in subsection 4.1.3.2 and this value can be constant in the range between maximum and minimum values or it can be adaptively changed in that range. What value is optimal in view of synchronisation performance and how to adaptively change the step size if needed is FFS>

The adaptive tracking scheme after initial synchronisation changes the TAB command period and timing control step size to reduce the impact of coarse initial synchronisation due to 3 chip resolution at initial synchronisation phase. In other words, when a UE enters USTS mode it can adjust its uplink transmission time with the timing control step bigger in size than that of the normal tracking process and the TAB command period shorter than that of the normal tracking process during initial several frames.

- The timing control step size is  $3 * \delta T$  for the first TAB period and the timing control step size is  $1/4$  for the other TAB periods
- A TAB command is transmitted to UE once every frame during the first three frames and is transmitted once every 2 frames (20ms) after three frames are transmitted.

## 4.2 Code usage for USTS (Code synchronisation)

### 4.2.1 Scrambling code

The long scrambling code described in Section 4.3.2.2. of TS 25.213 is used. However, this long scrambling code is not UE specific but is common to a number of UEs, and the initial loading value of PN generator is determined by the network. The spreading and modulation scheme for USTS is same as in Section 4 of TS 25.213.

In USTS mode, a number of UEs share a common scrambling code and the different and orthogonal channelisation codes needs to be allocated to each UE. To preserve orthogonality among channelisation codes, the UEs need to reset the generation of the common scrambling code at the same reference point (e.g., P-CCPCH frame time), whereas the UEs reset the generation of the UE specific scrambling code at their frame starting points without USTS. Figure 4. 3 shows a simple example with two UEs. Different UE uses different orthogonal codes to discriminate UE (exactly speaking, discriminate channel) and the UEs use a same scrambling code. Channelisation codes repeat at least every 256 chips but a scrambling code repeats every 10 msec (38400 chips). To obtain the orthogonal property in USTS

mode, the scrambling code has to be aligned at chip level as described in the Figure 4. 3 . Accordingly, two UEs are modulated with a same scrambling chip value if they are at the same time point.

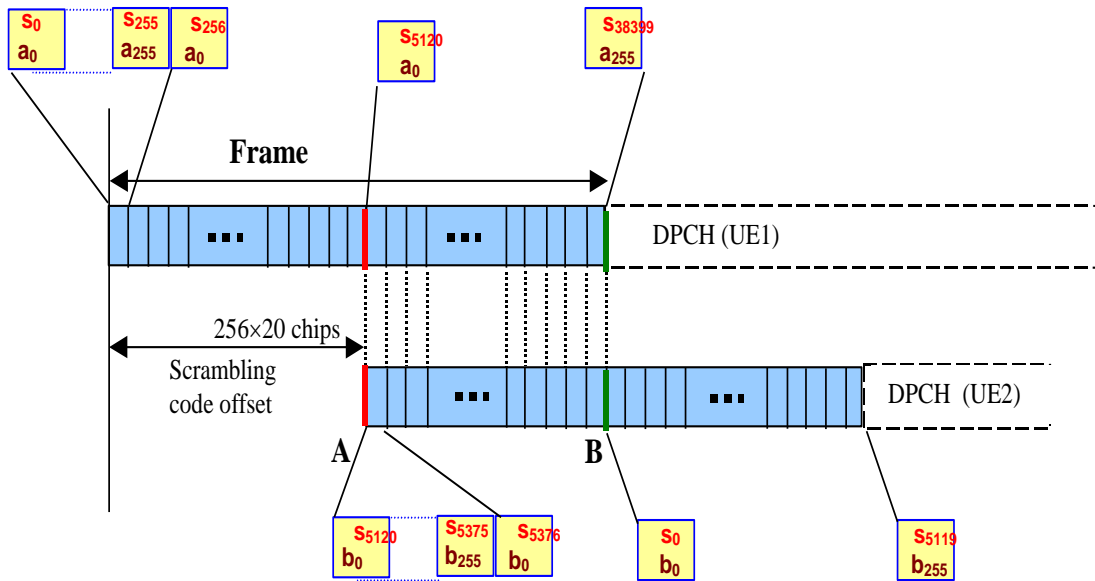

**Figure 4. 3 Timing at Node B and usage of scrambling and orthogonal codes in case of two UEs (a,b : channelisation codes, s : scrambling code, SF = 256)**

In order to prevent channelisation code shortage problem, more than one scrambling codes can be used. In this case, since the USTS gain can be obtained among the UEs sharing a same scrambling code, a careful scrambling code assignment is needed to maximise the USTS gain. For example, in case of two scrambling codes for USTS, if the channelisation codes of a scrambling code are used up, channelisation codes of an additional scrambling code can be used.

#### 4.2.1.1 UL scrambling code reference point

There is no restriction on defining reference point of UL scrambling code, and it may be chosen arbitrarily, for example P-CCPCH frame boundary. But, we can get some benefits from careful definition of the reference point. We propose to select the reference point at Node B as  $T_{ref} + T_0$  later from P-CCPCH frame boundary.

Figure 4. 4 depicts timing relations among P-CCPCH frame boundary, DL DPCH frame, UL DPCH frame, and reference points of common UL scrambling code. In the figure two reference points,  $T_0 + T_{ref}$  later from P-CCPCH frame boundary and P-CCPCH frame boundary, are treated.

In the former case, the scrambling code offset, difference between UL DPCH frame boundary and UL scrambling code boundary, is  $\tau_{DPCH,n}$ . That means the scrambling code of UL DPCH frame becomes  $c_{long}(i + \tau_{DPCH,n})$  ( $i=0,1, \dots, 38399$ ) where  $c_{long}(i)$  ( $i=0,1, \dots, 38399$ ) is the scrambling code sequence. And the scrambling code is reset at  $38400 - \tau_{DPCH,n}$ . (see Figure 4. 5).

In the latter case, the scrambling code offset is  $T_0 + T_{ref} + \tau_{DPCH,n}$ , and the scrambling code of UL DPCH frame becomes  $c_{long}(i + T_0 + T_{ref} + \tau_{DPCH,n})$  ( $i=0,1, \dots, 38399$ ). Thus the offset is determined by  $T_{ref}$  and  $\tau_{DPCH,n}$ .

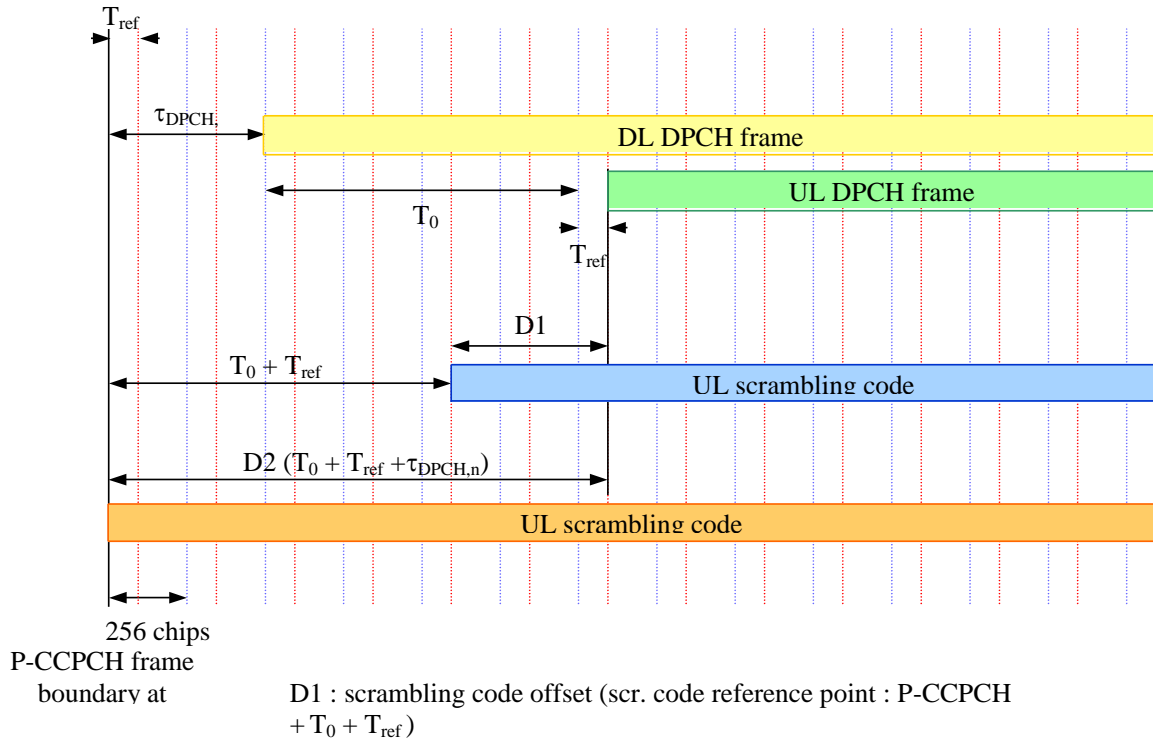

**Figure 4. 4 Reference point of UL scrambling code at Node B**

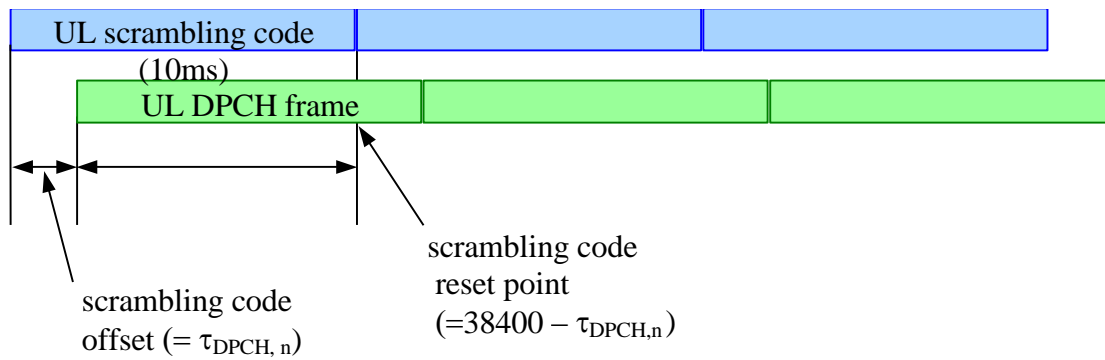

Figure 4.5 Scrambling code offset and reset point (scr. code reference point : P-CCPCH +  $T_0$  +  $T_{ref}$ )

## 4.2.2 Channelisation code allocation

Since UEs in USTS mode may share a common scrambling code, the UE discrimination is done by channelisation codes. At least two codes are needed to each UE: one for DPCCH and the other for DPDCH. In case of USTS, the channelisation codes for DPDCH(s) and DPCCH in a UE are chosen among unoccupied OVSF codes by other UEs from either upper half part or lower half part of OVSF code tree of a common scrambling code. The spreading factor and node number of channelisation code are delivered from network to each UE.

Reference: 3GPP TSG R1-99-581, "Channelisation code assignment for RSTS", ETRI.

### 4.2.2.1 Proposed OVSF code allocation rule for USTS

<This is one proposed way of doing code allocation>

The performance gain of USTS improves as more UEs share the same scrambling code. If OVSF codes are allocated inefficiently, fewer UEs can share the scrambling code. Since the SF of OVSF code for DPCCH is always 256 while the SF of OVSF code for DPDCH can be between 4 and 256, a special OVSF code allocation rule can be introduced to allocate OVSF codes to more UEs.

Mapping Rule of Channelisation Code between DPDCH and DPCCH is as follows:

- The sub-trees below the nodes  $C_{ch,8,3}$  and  $C_{ch,8,7}$  are reserved for DPCCH.
- **In the upper half code tree**, for the channelisation code for the DPDCH, the index  $k$  of  $C_{ch,SF,k}$  shall be chosen from the following range.

$$k = \begin{cases} 0,1,\dots,(\lfloor 3 \times SF/8 \rfloor - 1) & \text{if } SF \leq 64 \\ 0,2,\dots,46 & \text{if } SF = 128 \\ 0,4,\dots,92 & \text{if } SF = 256 \end{cases}$$

And, the channelisation code for the associated DPCCH shall be  $C_{ch,256,127-n}$ , where

$$n = 64 \times k / SF$$

- **In the lower half code tree**, for the channelisation code for the DPDCH, the index  $k$  of  $C_{ch,SF,k}$  shall be chosen from the following range.

$$k = \begin{cases} \lfloor 4 \times SF/8 \rfloor, (\lfloor 4 \times SF/8 \rfloor + 1), \dots, (\lfloor 7 \times SF/8 \rfloor - 1) & \text{if } SF \leq 64 \\ 64,66,\dots,110 & \text{if } SF = 128 \\ 128,132,\dots,220 & \text{if } SF = 256 \end{cases}$$

- And, the channelisation code for the associated DPCCH shall be  $C_{ch,256,255-n}$ , where

$$n = 64 \times k / SF$$

If more than one channelisation codes for DPDCHs are allocated to a UE, then the channelisation code for DPCCH corresponding to the first allocated channelisation code for DPDCH will be used as the channelisation code for the DPCCH.

#### 4.2.2.2 Channelisation codes for DPDCHs

As a summary, there are two rules for channelisation codes assignment for both a DPCCH and DPDCH(s):

- (1) The channelisation codes for DPDCH(s) and a DPCCH for a UE are chosen among OVSF codes unoccupied by other UEs from either upper half part or lower half part of OVSF code tree of a common scrambling code.
- (2) Mapping rule of channelisation codes between DPDCH and DPCCH.

Table 4.1 shows the number of channelisation codes for DPDCHs given one DPDCH and one DPCCH per UE. The numbers in the column "4.2.2.1" is given when both rules are obeyed. However, if the second rule is taken away, then, the numbers are increased especially when  $SF \geq 64$  while this requires a signalling for DPCCH code at call set-up. The numbers in parenthesis can be obtained when both rules are not obeyed.

**Table 4.1 Number of channelisation codes for DPDCHs.**

Spreading factor	Number of codes for DPDCHs	
	4.2.2.1	Maximum
4	2	2(3)
8	6	6(7)
16	12	14(15)
32	24	28
64	48	50(51)
128	48	84(85)
256	48	128

### 4.3 Soft handover in USTS mode

<This section is describing only sample candidates which is restricted to USTS Study report and not universal description of soft handover procedure>

For seamless communication, soft handover needs to be considered for USTS, where the different code usage of scrambling and channelisation codes, and the transmission timing control should be taken into account.

#### 4.3.1 Handover in USTS mode

##### 4.3.1.1 Three modes for soft handover in USTS mode

The radio link can be in one of the following three modes:

- Normal mode : No timing control, UE discrimination by Scr code
- USTS mode : Timing control, UE discrimination by both Scr and Ch codes
- Non-USTS mode : No timing control, UE discrimination by both Scr and Ch codes

The difference between Normal mode and Non-USTS mode is as follows. If one of the radio links to the cell sites in Active set is in USTS mode, it is discriminated by both scrambling code and channelisation codes assigned for USTS mode in all cells in Active set. Therefore, the other links should be in non-USTS mode. This is because the UE has only a single transmitter and there can be more than one UEs who enter the SHO region from the same original cell and accordingly, they use the common scrambling code and the discrimination can be done only by channelisation codes. The UE in USTS mode has an USTS-mode RL and non-USTS mode RL(s). In normal mode, the UEs in SHO region use their own unique scrambling codes.

The capabilities and functions of UE and Node B are listed in the Table.

UE capable of USTS	Node B capable of USTS	
USTS mode UE	USTS mode Node B	Non-USTS mode Node B
<ul style="list-style-type: none"> <li>- Tx timing control according to Tinit_sync and TAB commands delivered from an USTS mode Node B (time synchronisation)</li> <li>- Scr/Ch codes generation for USTS (code synchronisation)</li> </ul>	<ul style="list-style-type: none"> <li>- Generation of TAB commands (time synchronisation)</li> <li>- Discrimination of UE based on Scr/Ch codes for USTS (code synchronisation)</li> </ul>	<ul style="list-style-type: none"> <li>- Discrimination of UE based on Scr/Ch codes for USTS (code synchronisation)</li> <li>- No time synchronisation</li> </ul>

Note 1) Tinit\_sync is calculated at the RNC and then, delivered to the corresponding UE through Node B.

### 4.3.1.2 Three procedures for handover in USTS mode

For handover in USTS mode, the following three procedures are necessary: RL addition, RL deletion, mode change. The first two procedures are quite similar to those in normal mode.

- (1) RL addition procedure is performed to add a new non-USTS mode RL to a target Node B capable of USTS. The target Node B needs to be informed of the necessary information such as scrambling code, scrambling code offset, and channelisation codes of the existing USTS mode RL. The diversity reception is working during handover in USTS mode.
- (2) The RL deletion procedure drops one RL, where the UE and a corresponding Node B are engaged in this procedure.
- (3) The last procedure is devised for non-USTS to USTS mode change. This procedure requires an RL reconfiguration. It includes scrambling and channelisation codes reassignment at both UE and Node B for code synchronisation, and transmission timing control so that the UE is time-synchronised to a new Node B.

### 4.3.2 Four candidates in case of two-way handover

Four candidates for supporting soft handover have been proposed in USTS mode. Table 4.1 summarises these candidates. In this section, only two-way soft handover is considered for easy understanding. In Candidate 1, when the UE enters SHO region, it abandons the USTS mode and operates in normal mode with both cell sites. For this, a reconfiguration process is first required to assign new scrambling codes and channelisation codes for the radio link with the original cell and then, the normal soft handover procedure is followed. When the UE moves further into the target cell and leaves out of SHO region, it continues to be in normal mode with stronger radio link. If it leaves out of SHO region back into the original cell, it resumes the USTS mode and accordingly, for normal to USTS mode transition, reconfiguration process is required to assign new scrambling code and channelisation codes, and timing adjustment is necessary. Candidate 2 is different from Candidate 1 only in that the soft handover happens in the reverse direction.

In Candidates 3 and 4, the UE continues to be in USTS mode with either of two cell sites in SHO region, which may provide better performance. In Candidate 3, the UE keeps the radio link with the original cell site being in USTS mode until it moves out of the coverage of the original cell. When the UE drops the radio link with the original cell, it changes the mode of the radio link with the target cell to USTS mode. At this point, reconfiguration of scrambling and channelisation codes and also the timing control are required for non-USTS to USTS mode transition. If the UE returns to the original cell, just dropping the weaker radio link is the only thing the UE has to do.

In Candidate 4, the radio link modes of both links are changed in the middle of soft handover, which may improve the performance by providing USTS mode to a better radio link compared to Candidate 3. When the change point is at the cell boundary, Candidate 4 is the same as Candidate 3. And therefore, Candidate 3 can be seen as a special case of Candidate 4. If the change point is anywhere inside the SHO region, the optimum point and how to detect it need to be elaborated further.

**Table 4.2 Four soft handover candidates for USTS (A simple example in case of two-way soft handover).**

	The mode of UE
--	----------------



Movement of UE	In original cell	In SHO region	In target cell
Candidate 1	USTS	Normal(O)+Normal(T)	Normal
Candidate 2	Normal	Normal(O)+Normal(T)	USTS
Candidate 3	USTS	USTS(O)+Non-USTS(T)	USTS
Candidate 4	USTS	USTS(O)+Non-USTS(T) → Non-USTS(O)+USTS(T)	USTS

Note (O): the mode with the **original** cell (T) : the mode with the **target** cell

### 4.3.2.1 Detailed description on Candidate 3

Figure 4. 6 shows handover procedure for candidate 3 in more details. Both cells are capable of USTS, and UE2 and UE3 are in USTS mode with Node B1 and Node B2, respectively. When UE1 has an RL in USTS mode, Node B1 assigns Scr1 and Ch3 to UE1. During soft handover, UE1 continues to use these codes and continues to be in USTS mode with Node B1. However, when UE1 is in SHO, it has another non-USTS mode RL with Node B2 because Tx timing of UE is controlled only to Node B1. The macro-diversity combining can be performed in the uplink with an USTS mode RL and a non-USTS mode RL. When the UE1 moves out of SHO region, the original USTS mode RL is released and a reconfiguration of the remaining RL is performed for non-USTS to USTS transition. The amount of timing adjustment can be calculated with Round trip time (accordingly, RTPD). At this point, the UE adjust its Tx time according to the informed amount and new scrambling and channelisation codes are assigned. Then, the old non-USTS mode RL is released and a new USTS mode RL is established between UE and a target Node B. The same procedure is also required for normal to USTS mode transition.

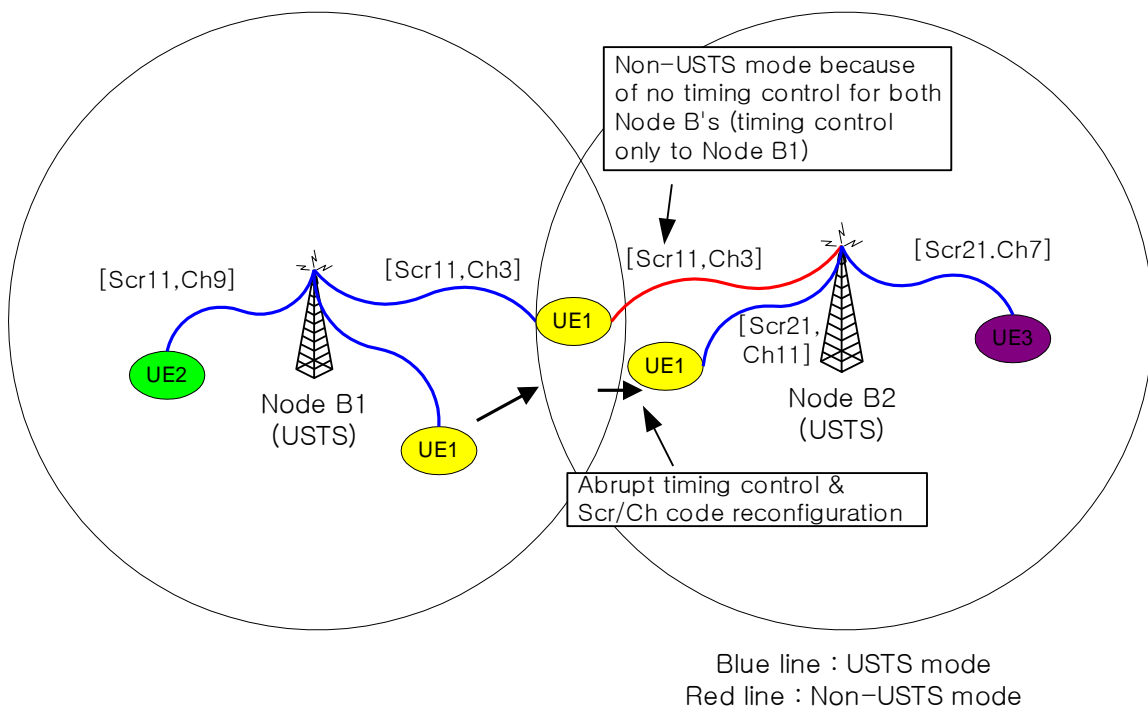

**Figure 4. 6 Two-way soft handover procedure for Candidate 3.**

### 4.3.2.2 Detailed description on Candidate 4

Figure 4. 7 shows the handover candidate 4 in two-cell layout. Both Node Bs are operated in USTS. UE1 and UE2 are operated in USTS with Node B #1 and Node B #2, respectively. Let us focus on UE0 with interest. When UE0 is operated in USTS with Node B #1, UE0 gets scrambling code (Scr11) and channelisation code (Ch3) from Node B #1. When UE0 enters into the handover process, the radio link in non-USTS mode with Node B #2 is set up. Note that only Node B #1 controls the transmit timing of UE0, which uses the same codes and is operated in USTS with Node B #1. While UE0 exists in the soft handover region, the reconfiguration process is required to assign new scrambling code (Scr21), channelisation code (Ch11) and timing adjustment for non-USTS to USTS transition in Node B #2. Also USTS to non-USTS transition in Node B #1 is required to preserve the reliability from soft handover. The required timing adjustment for new USTS link can be obtained by RTPD and Tref in the same manner with candidate 3. Timing of non-USTS link in Node B #1 is acquired by the new USTS time adjustment and the time difference between Node B #1 and Node B #2. Finally, UE0 releases the radio link with Node B #1 when the UE0 does not need soft handover and soft handover process is completed.

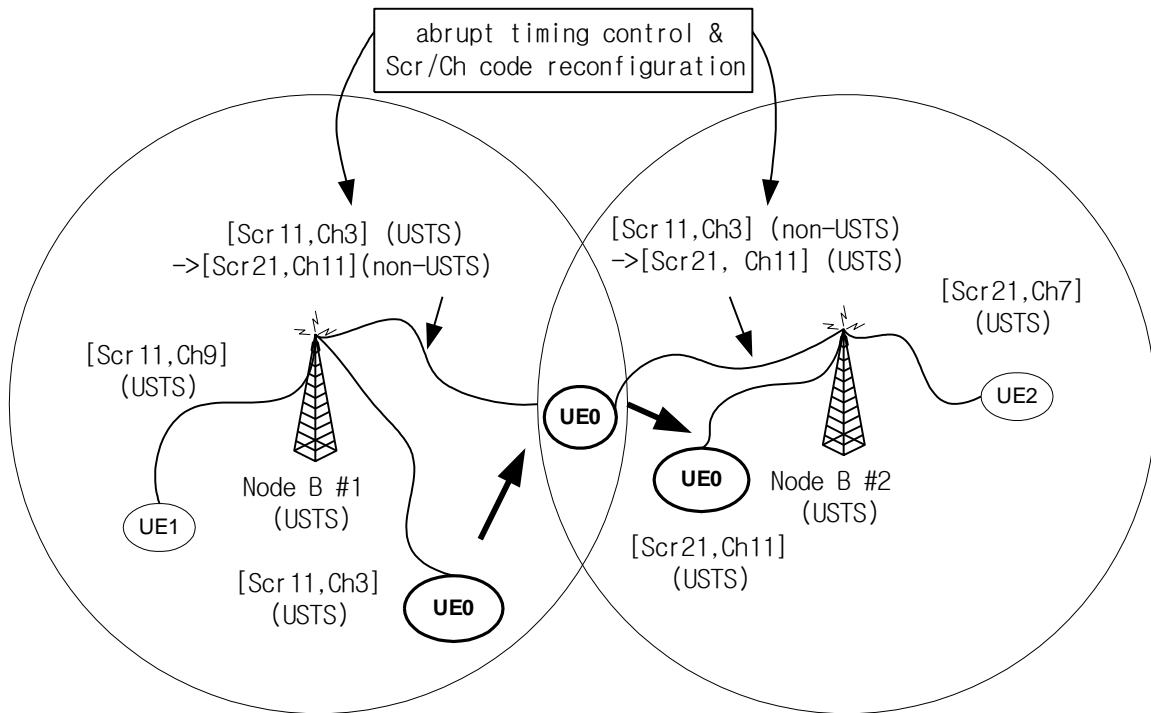

Figure 4. 7 Two-way soft handover procedure for candidate 4.

Reference

R1-01-0061, "Comparison of soft handover for USTS", LGE

4.3.2.3 Arrival timing at Node B's

Figure 4. 8 describes the arrival timing at Node B1 and Node B2. The arrival times from UEs in the Node B1 are controlled to be  $\tau_{DPCH,li} + T_0 + T_{ref}$  from the beginning of P-CCPCH1. Since  $\tau_{DPCH,li}$  is a multiple of 256 chips, the possible arrival point at Node B1 repeats every 256 chips. During soft handover, UE3 is in USTS mode with Node B1 and therefore, its arrival time at Node B1 is kept at  $\tau_{DPCH,13} + T_0 + T_{ref}$ . However, even though the UE3 is in SHO with Node B2, it is in non-USTS mode because the arrival time at Node B2 is not controlled to guarantee synchronized reception with UE4 & UE5. When UE3 moves further into Node B2 area and drops the old link, then in order to be in USTS mode with Node B2, the arrival time at Node B2 needs to be controlled. Point a or point b can be chosen for USTS and their difference is 256 chips. To prevent abrupt timing advance at UE side, point b is always selected and therefore, transmission gap may result, which is less than 256 chips, i.e., the transmission at UE needs to be stopped for less than 256 chips and resumes after the gap. For this,  $\tau_{DPCH,23}$  needs to be reassigned when selecting point b.

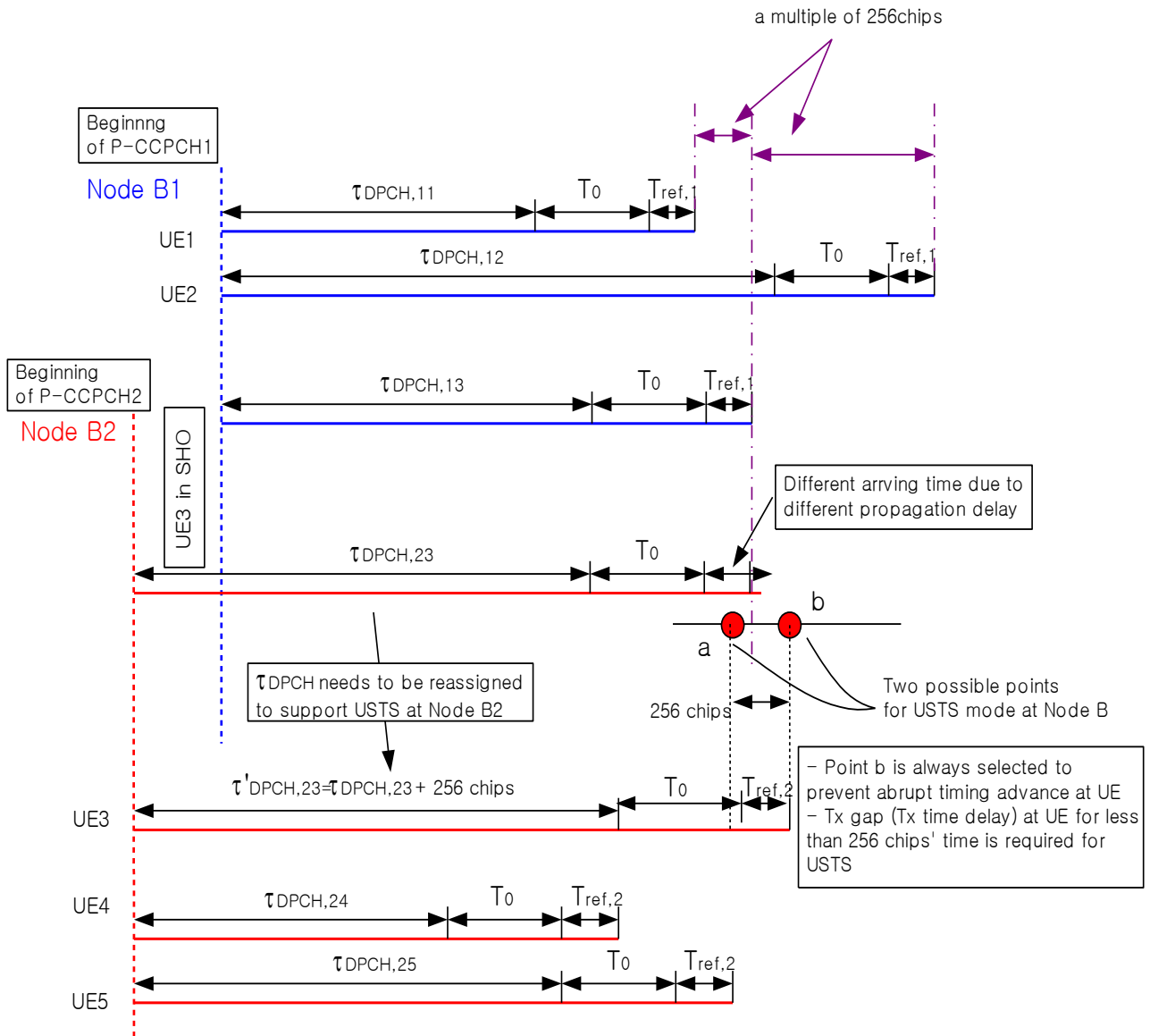

Figure 4. 8 Arrival timing at Node B1 and Node B2

---

## 5 Performance

### 5.1 Simulation parameters

- The first detected paths (in time) of UEs are aligned
- Channel model : outdoor urban high-rise channel model (JTC)
  - : ITU indoor and pedestrian models
- Number of Rake fingers = 1, 3
- Mobile speed : 3 km/h, 5.6 km/h, 20 km/h, 60 km/h
- SF : 128
- Single cell
- Closed power control : OFF
- Channel estimation : Ideal
- No channel coding
- Number of oversamples per chip : 4, 8
- Modulation/Spreading : QPSK/complex, BPSK
- Carrier frequency : 1.9 GHz, 2 GHz

## 5.2 Simulation results

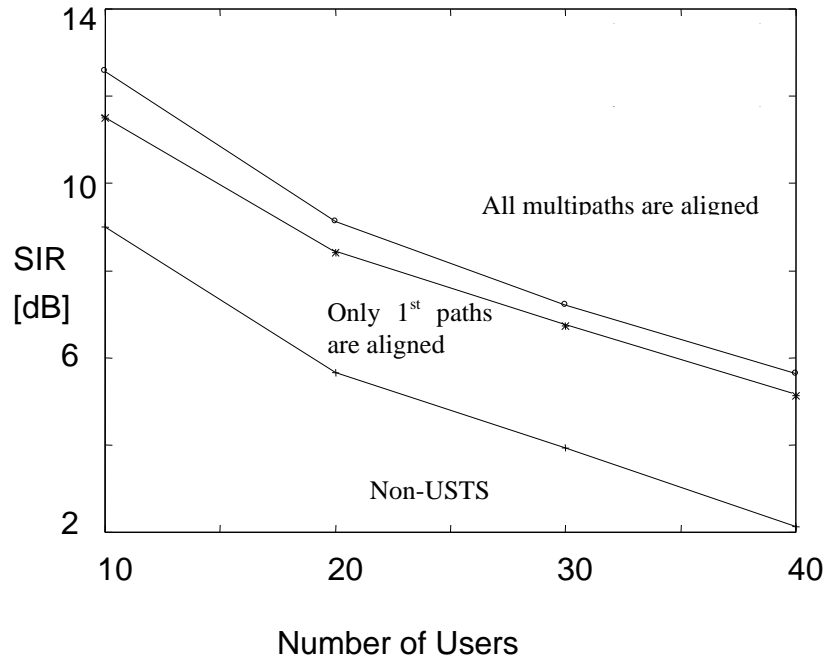

**Figure 5.1 SIR comparison for varying the number of users under JTC channel model**

- Channel model : outdoor urban high-rise channel model (JTC)
- Number of Rake fingers = 3
- Mobile speed : 5.6 km/h
- All UEs are either in USTS mode or in non-USTS mode
- Timing alignment precision : [-1/8 chip, +1/8 chip]
- Modulation/Spreading : BPSK
- Carrier frequency : 1.9 GHz

- About 3 dB gain in SIR can be achieved compared to non-USTS

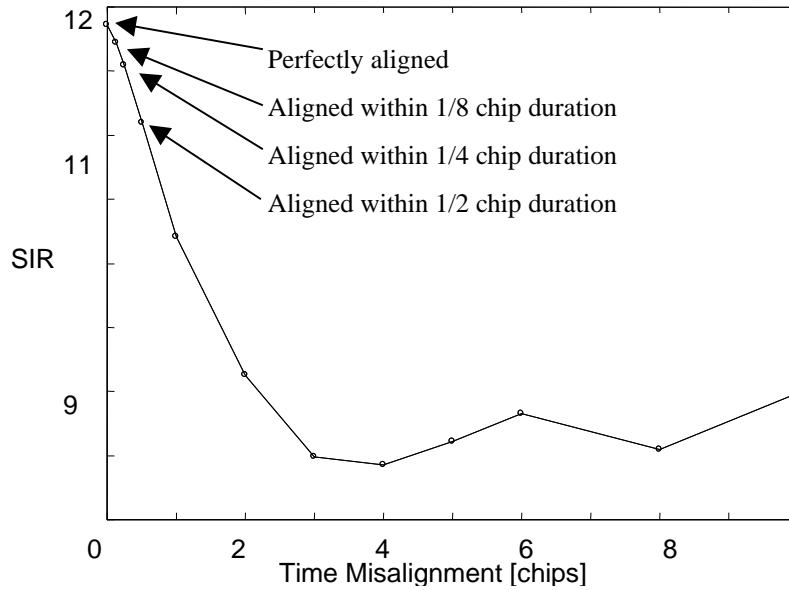
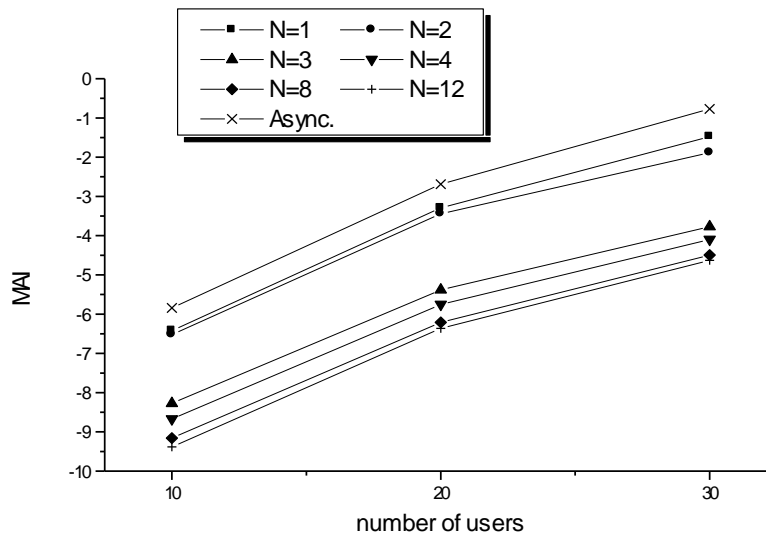

**Figure 5.2 Impact of timing control resolution.**

- Number of users = 10
- All UEs are in USTS mode
- Channel model : outdoor urban high-rise channel model (JTC)
- Number of Rake fingers = 3
- Mobile speed : 5.6 km/h
- Modulation/Spreading : BPSK
- Carrier frequency : 1.9 GHz

Note: The amount of misalignment is randomly chosen in the range of  $[-x,+x]$  chips and therefore, the arrival times of UEs are randomly distributed around the desired arrival time.

Note: If the amount of misalignment is larger than 3 chips, the obtainable SIR in USTS mode is the same as in non-USTS mode (refer to Fig. 5.1)



**Figure 5.3 Timing control rate versus channel variation rate**

- All UEs are in USTS mode
  - Channel model : ITU-R Vehicular B model
  - Number of Rake fingers = 3
  - Mobile speed : 20 km/h
  - Modulation/Spreading : BPSK
  - Carrier frequency : 1.9 GHz
  - Timing control step size = 1/4 chip
  - $N$  = the ratio of timing control rate to average channel variation rate
  - The average channel variation interval = 100 msec
  - Delay variation is randomly selected from  $[0,1]$  chip range
- For  $N > 3$ , the additional performance improvement is less than 1 dB.



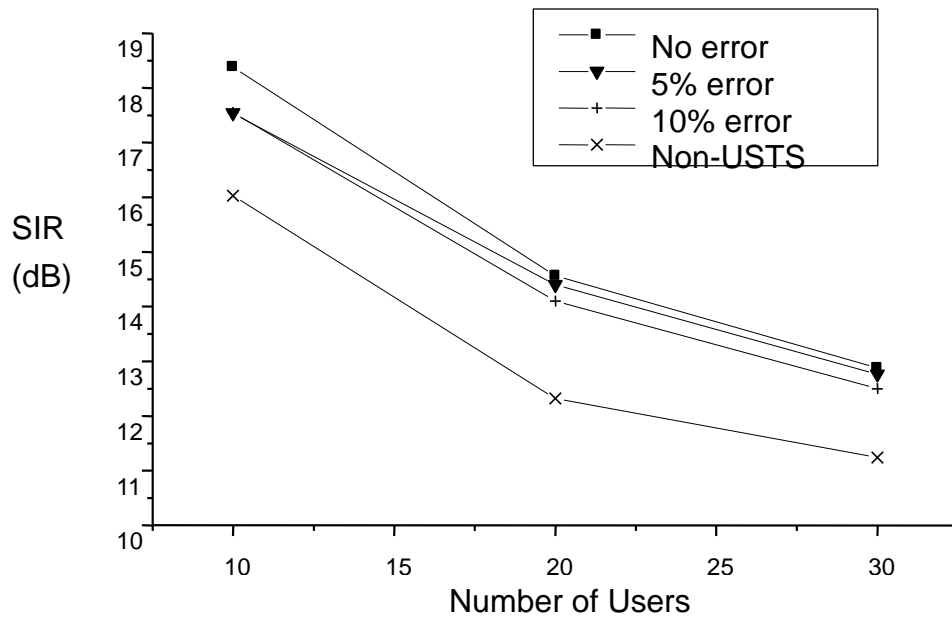
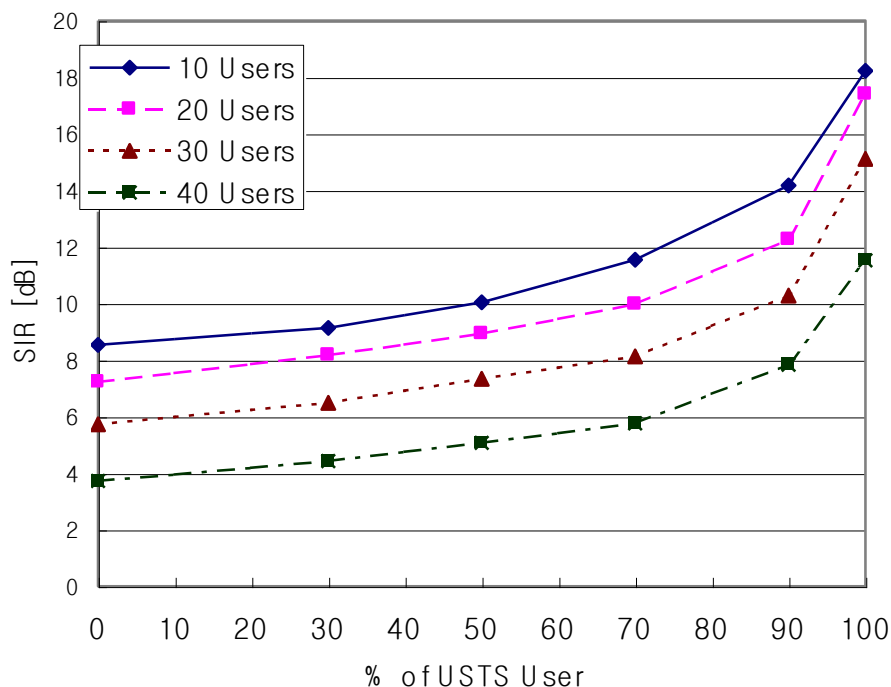

Figure 5.4 Impact of TAB error

- All UEs are in USTS mode
  - Channel model : ITU-R Vehicular B model
  - Number of Rake fingers = 3
  - Mobile speed : 60 km/h
  - Modulation/Spreading : BPSK
  - Carrier frequency : 1.9 GHz
  - Timing control step size = 1/4 chip
  - Timing control interval = 25 msec
  - The average channel variation interval = 100 msec
  - Delay variation is randomly selected from [0,1] chip range
- For less than 10 % error in TAB, the performance degradation is less than 1 dB in SIR.



**Figure 5.5 Performance in a USTS/non-USTS mixed situation**

- Channel model : Pedestrian A (Speed : 3 km/h)
- Number of oversamples per chip : 4
- Carrier frequency : 2 GHz
- Number of fingers = 1
- Modulation/Spreading : QPSK/complex
- Chip rate : 3.84 Mcps

Note 1: Under the above channel model, the first three paths are very close to each other so that they are within one chip duration and therefore, they are not discriminated. And the signal powers of the other paths are very small. Accordingly, choosing one Rake finger in the simulation is reasonable under this channel model.

Note 2: The percentage of USTS users largely affects the performance gain. In case of Candidates 2 and 3, if all UEs support USTS, then 30 % of them are usually in SHO. If the multiple cell system is taken into account, no more than 85 % of UEs can be in USTS mode from the view point of the cell under consideration.

Note 3: Compared to the single cell system, if multiple cell (other cell) and soft handover are taken into account, the performance gain of USTS is reduced. For example, if the other cell interference factor  $f$  is 0.77 and half of the UEs in SHO are assumed to be in non-USTS mode, the gain is reduced by half approximately. However, the performance gain of USTS is still high, especially in indoor and dense pedestrian environments.

**Table 5.1 Average SIR comparison under various channel models (10 UEs).**

Channel model	USTS (100 %)	Non-USTS (100 %)
Indoor A	14.57 dB	9.02 dB
Indoor B	12.78 dB	7.49 dB
Pedestrian A	18.22 dB	8.54 dB
Pedestrian B	11.42 dB	8.73 dB

Note: We also have simulation results in Indoor A and Pedestrian B channel models. As more strong multipaths exist, the performance gain of USTS decreases. However, since in most cases of indoor or pedestrian environment, the first detected path is relatively stronger than any other paths, good performance gain can be expected by using USTS.

## 5.3 Capacity gain

**Table 5.2 Main simulation parameters**

Parameter	Assumptions	Comments
Cellular Layout	7-cell	Hexagonal grid (wrap-around technique)
Sector / cell	1	Omni-cell
Radius of Cell	577 m	Micro cell
Path Loss	$L=15.3 + 37.6 \log_{10}(R)$	R in meter
Carrier Frequency	2 GHz	
Shadowing	Lognormal distribution	
Std. deviation of Shadowing	5 dB	
Correlation Between Cell Sites	0.5	
Correlation Distance of Shadowing	110 m	
Multipath Fading Profile	Pedestrian A	ITU-R M.1225 (Generated by Jakes model)
Doppler Spectrum	Classic	
Velocity of UE	3 km	Constant
Maximum UE Tx Power	21 dBm	
Traffic Model	Constant Bit Rate (12.2 kbps Speech)	SF=128 (30kbps after channel coding & puncturing)
Uplink Eb/No target (before channel decoding)	4.5 dB	Perfect closed loop PC, No outer loop PC
SHO Add / delete /replace	2 / 4 / 2 dB	Candidate 4
Maximum active set size	2	
USTS UE / (USTS UE + Normal UE)	0.0 ~ 1.0	
Multiple scrambling code	$\geq 1$	Sequential packing
Uplink Synchronisation	Perfect	Among the first paths

**Table 5.3 Number of users and USTS gain as a function of penetration ratio**

Penetration	Normal	40 %	60 %	80 %	100 %
No of users	58	62	67	77	90
USTS gain [%]	-	7	16	33	55

Note: When 48 codes are available, the USTS has to use two common scrambling codes and the USTS gain is 29%. However, when 84 codes are used, the gain increases to 55% with sequential packing for multiple scrambling codes. The impact of penetration ratio has been observed with antenna diversity. With a penetration of 50%, the expected gain of USTS lies around 10%. However, it reaches 33% at 80% penetration and eventually 55% when all users use USTS mode.

## 5.4 Eb/No impact of using SF=128 instead of 64

**Table 5.4 (Link level) simulation parameters**

Parameter	Value	Comments
Traffic	Data	12.2 kbps
	Control	2.4 kbps
Propagation condition	Single path	Pedestrian A (3 km/h)
Fast fading model	Jakes spectrum	
Closed loop power control	ON	Step size = 1 dB No TPC error (Perfect)
Channel estimation	Perfect	
Channel coding	1/3 rate convolutional	SF=64
	1/2 rate convolutional	SF=128
Antenna diversity	2-branch	
Noise power	-174 dBm	

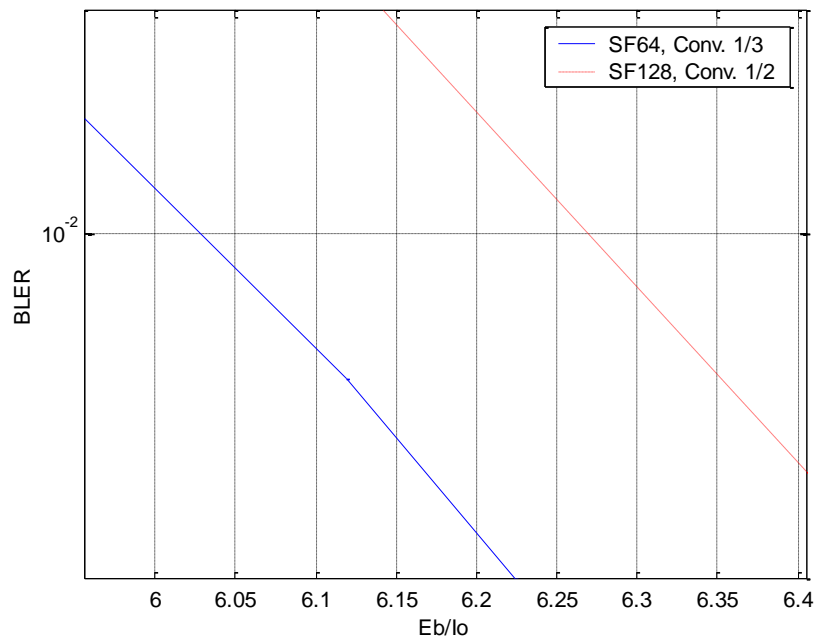

**Figure 5.6 BLER versus Eb/No with 12.2 kbps DTCH and 2.4 kbps DCCH**

Note: From the above link level simulation results, we can see the impact of using SF=128 instead of SF=64 on the Eb/No level satisfying BLER = 1%. There is only 0.3 dB degradation in Eb/No and accordingly, we can conclude SF=128 can be used without causing significant degradation in terms of Eb/No, where convolutional coding rate, radio frame segmentation, and RM parameters are different.

## 5.5 System simulations on USTS gain in Pedestrian A environment

**Table 5.5 The parameters used in the system simulations.**

Cell Plan	Number of Sites	8
	Number of sectors per site	3
	Cell radius	300 m
	Number of rx antennas per cell	1, 2
Propagation	Path loss with distance	$L[\text{dB}] = 147.7 + 40 \log d[\text{km}]$
	Standard deviation of shadow fading	10 dB
	Coherence distance for shadow fading	50 m
	Power delay profile	Pedestrian A
	Receiver antenna gain	15 dBi
	Thermal noise level	-102.9 dBm
	SHO	Add / Drop / Replace
Time before dropping		0.02 s
Maximum active sets size		2
Algorithm for synchronising in SHO		Candidate 3
AC	AC period	20 ms
	Noise Rise Target	4 dB
PC	Fast closed-loop PC step size	1 dB
	Outer-loop PC step size	0.3 dB
	FER target	1 %
Mobile	Effective bit rate	12.2 kbps (speech service)
	Speed	3 km/h
	Voice activity factor	1, 0.5
	Maximum transmitted power	24 dBm
Simulation time		120 s

Tables 5.6 and 5.7 show the maximum number of users per cell for multi cell environment with and without USTS. A gain of 28.8% can be obtained with USTS in Pedestrian A for spreading factor 128, 2 antennas and voice activity factor of one. With a voice activity factor equal to 0.5 and spreading factor 64 the code restriction is very severe, since in approximately 60% of the time the Node Bs are using a third scrambling code, and in 40% they have to go for a fourth one. In this case, the capacity gain of USTS decreases to 8.6%, whereas simulations run assuming no channelisation code restriction yield a 33.8% capacity gain.

Further simulations have been executed for a single micro cell environment (i.e., there is no other cell interference and no soft handover) with omni antenna. The rest of the parameters are the same as for the multi cell case. The most optimistic case is the one with only one receiver antenna at the Node B, a spreading factor 128, and voice activity factor equal to one, where USTS gives a 82.9% capacity increase. However, for voice activity factor of 0.5, 2 branch antenna diversity and SF=64 then USTS only provides a capacity increase of 11.8%.

It must be noted that voice activity factor 0.5 does not relate to services with characteristics different from speech. The actual USTS gain would thus be between the figures for voice activity factors 1.0 and 0.5.

SF	Number of rx Antennas	Voice activity factor	Users without USTS	Users with USTS	Gain
64	1	1.0	27.2	34.8	27.9%
64	1	0.5	54.3	62.4	14.9%
64	2	1.0	60.6	71.0	17.1%
64	2	0.5	121.2	131.7	8.6%
128	1	1.0	27.2	34.8	27.9%
128	1	0.5	54.3	68.6	26.3%
128	2	1.0	60.6	78.1	28.8%
128	2	0.5	121.2	138.3	14.1%

Table 5.6. Number of speech users per cell in multi cell environment

SF	Number of rx antennas	Voice activity factor	Users without USTS	Users with USTS	Gain
64	1	1.0	47	65	38.2%
64	1	0.5	94	112	19.1%
64	2	1.0	93	114	22.5%
64	2	0.5	186	208	11.8%
128	1	1.0	47	86	82.9%
128	1	0.5	94	124	31.9%
128	2	1.0	93	125	34.4%
128	2	0.5	186	220	18.2%

Table 5.7. Number of speech users per cell in single cell environment

---

## 6 Complexity issue

### 6.1 Introduction

This section discusses the complexity of USTS in terms of timing control, different scrambling and channelisation code usage, soft handover processing, and the impact on closed loop power control. Both hardware and computational complexities are presented in this section.

### 6.2 Timing control complexity

Timing control is required for synchronised reception in the Node B at initial synchronisation phase, tracking process during call, and at normal/non-USTS to USTS mode transition for soft handover. UE advances or delays its transmission time by a given amount of time delivered from Node B for initial synchronisation and tracking process. However, UE only performs transmission time delay at mode transition to USTS for soft handover to prevent possible data loss due to abrupt time advance, which may require DL timing adjustment. Node B needs to measure PRACH Propagation delay at call setup phase and report it to RNC. Then, RNC calculates  $T_{INIT\_SYNC}$  using the reported value and  $T_{ref}$  and then, inform the corresponding UE of this value through FACH. During tracking process, Node B continuously measures the DPCH frame arrival time and compares it with the desired arrival time. Then, it punctures the TPC bits with the TAB commands. For this timing control, some computational complexity is expected in RNC, Node B, and UE, which may need additional processing power or hardware but is expected to be quite small due to its simple arithmetic operation. Additional signalling is needed to carry the amount of timing adjustment. However, for tracking process there is no signalling load increase because tracking process carries the information by puncturing TPC bits. Since USTS is targeting indoor and dense pedestrian environments, handover does not occur so frequently. Moreover, the additional signalling load per call is expected to be quite small, compared to the total signalling load. Only a small amount of signalling load increase is expected at call setup phase and for handover.

### 6.3 Different scrambling/channelisation code usage

USTS assigns scrambling/channelisation codes differently from current specifications to get orthogonal property in the uplink. Since it uses the same scrambling/channelisation code generators, USTS requires a small additional hardware. However, differently from the current specifications, the same initial loading value for scrambling code and different channelisation code(s) are assigned to the UEs in USTS mode (there may be an exceptional case when more than one scrambling codes are used for USTS). RNC may need additional computation not to violate this rule. Regarding channelisation code assignment, if properly designed, only the information about the DPDCH channelisation code(s) needs to be delivered to UE. This is applied for call setup and mode transition in handover.



## 6.4 Soft handover complexity

Timing control complexity and different assignment of scrambling/channelisation codes are discussed in the previous two subsections. Most of the complexity for soft handover is related to higher layers and will be dealt with in WG2 and WG3. UL/DL timing related issues in soft handover will be discussed in the following subsection because it is closely related to the CLPC.

**Table 6.1 Complexity comparison of four soft handover candidates (two-way case, O: Original cell, T: Target cell)**

Case	Candidate 1	Candidate 2	Candidate 3	Candidate 4 *
Adding a new link	Scr/Ch code reconf. (O,T,UE)	Radio link setup (T)	Radio link setup (T)	Radio link setup (T)
Dropping the link with original cell	Nothing	Scr/Ch code reconf. (T,UE) &  Timing adjust. (T,UE)	Scr/Ch code reconf. (T,UE) &  Timing adjust. (T,UE)	Nothing
Dropping the link with target cell	Scr/Ch code reconf. (O,UE) &  Timing adjust. (O,UE)	Nothing	Nothing	Scr/Ch code reconf. (O,UE) &  Timing adjust. (O,UE)
At mode transition within SHO region	Not occur	Not occur	Not occur	Scr/Ch code reconf. (O,T,UE) &  Timing adjust. (T,UE)

\* In candidate 4, the mode transition is assumed to occur within SHO region. If it occurs at the boundary, Candidate 4 is the same as Candidate 3.

The proposed soft handover candidates 3) and 4) need the timing adjustment and code assignment process, in order to operate in USTS mode at target Node B. The reason why both timing adjustment and code assignment are operated is to get performance gains from orthogonality by USTS. The criterion that makes the reconfiguration process be operated is different in 3) and 4). In candidate 3), it is whether UE exists inside handover region or out of the region. However, the reconfiguration process occurs inside the soft handover region in 4). Even though the detailed procedures are beyond WG1's interests, UTRAN can select the proper timing for the reconfiguration process, because it selects the better frame between the two possible candidates within RNC, or knows the number of UEs in USTS mode at each Node B and pilot signal power of each UE from the reception of the measurement. The candidate 4) can provide more reliable USTS link at target Node B, because the UE obtains better channel conditions during handover process. As well, there would be more interference of a UE penetrating into target Node B without being timing alignment by USTS in 3) comparing with 4). That is because the timing change of target Node B always occurs outside the handover region. Such effects are more important in three-way soft handover. Figure 6.1 shows three-cell layout for candidate 3). When a UE gets out of USTS area with Node B #1, it should be decided whether USTS would be operated with Node B #2 or Node B #3 in soft handover region. In addition, non-USTS link should be set-up with the other Node B to keep the soft handover. Therefore, the reconfiguration process needs for candidate 3) in three-way soft handover operation like candidate 4). As well, there exist more chances to operate the soft handover in 4) for three-cell situation than in 3), which can reduce the interference to target Node Bs and improve the link performances. Ping-pong effects can be reduced by hysteresis as a similar manner with the handover method in Release 99. As explained above, the candidate 4) may give more reliable performance. However, complexity is expected to increase because the reconfiguration process needs to happen at original Node B. If USTS to non-USTS transition in original Node B does not happen, then the candidate 4) is the same with 3) except the point that handover takes place inside the handover region. Thus, the candidate 4) is a more general approach of soft handover for USTS.

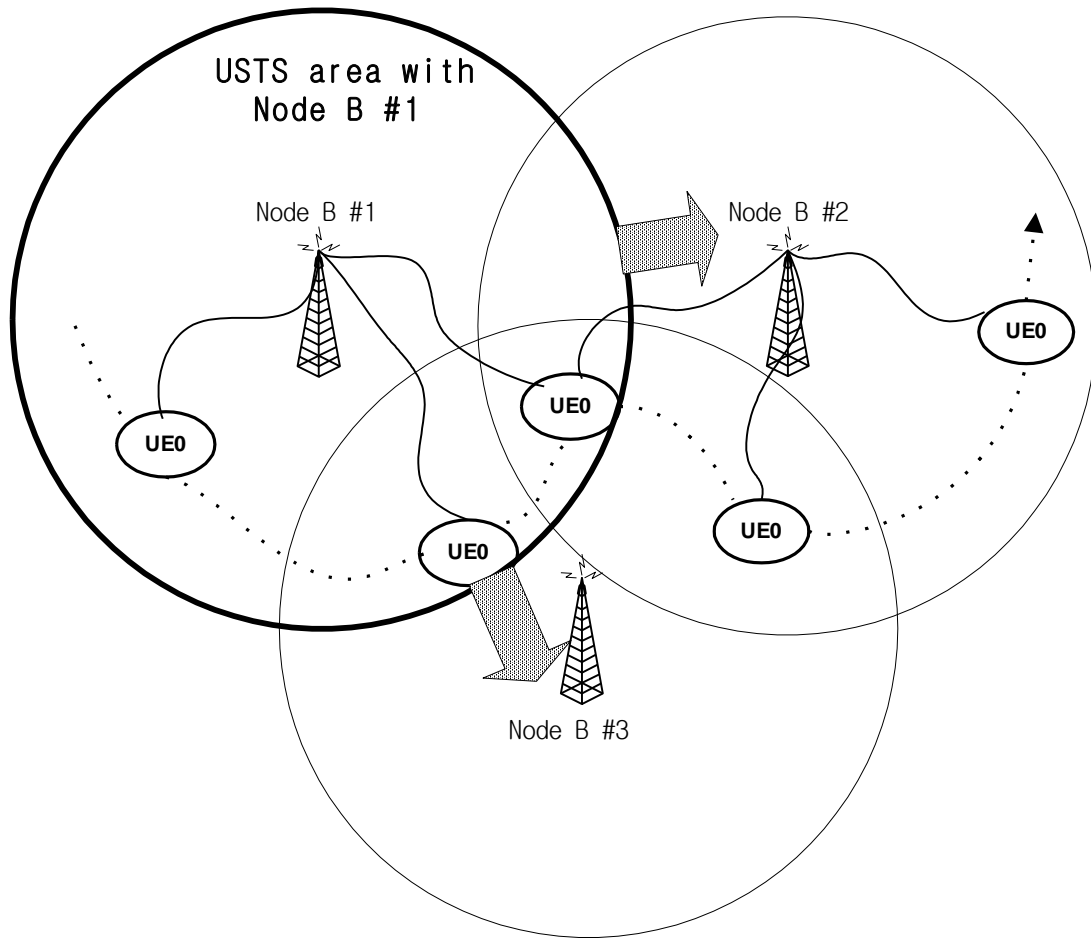

**Figure 6.1. Three-way soft handover situation for candidate 3.**

Reference: R1-01-0061, "Comparison of soft handover scheme for USTS", LGE.

## 6.5 Impact on closed loop power control

If the transmission time of UE can be adjusted at the initial synchronisation phase and during the call (DL timing stays the same), then UL/DL relative timing does not stay fixed. This relative timing is up to  $T_{ref}$  and the UE capability (CLPC processing budget). An appropriate value for  $T_{ref}$  can be found so that UL/DL relative timing is kept within the range of  $T_0 \pm T_{ref}$  chips. This is the case when  $T_{ref}$  is set to be the maximum one-way propagation delay and CLPC delay can be kept at 1 slot for  $T_{ref} < 148$  chips (this corresponds to about 11.5 km cell radius with a chip rate of 3.84 Mcps). And according to the current specifications, during soft handover, UL/DL timing is within  $T_0 \pm 148$  chips without USTS. With USTS, the DL arrival timings from the cells in Active set remain unchanged and only the UL transmission timing varies and accordingly, the range can be shifted so that the DL arrival times occur  $T_0 \pm 148$  chips earlier than the UL transmission time. Or, the power control may take more than one slot time. Also as the amount of timing adjustment varies faster in a wider range, the DL timing adjustment may occur more frequently. The trade-off between the performance degradation due to longer power control loop delay and the signalling load to adjust the DL timing needs to be taken into account.

USTS affects the performance of CLPC because TAB commands punctures TPC bits at a timing control rate. However, compared to the attainable performance gain, performance degradation due to puncturing, for example, one out of 30 TPC bits is much smaller. This is because USTS can mitigate the effect of imperfect power control by preserving orthogonal property among channelisation codes.

## 6.6 Rx-Tx timing relation at UE in the USTS mode

In the normal mode it is expected that UE Tx time is separated from the first received finger by  $T_0$ . But the difference between Rx and Tx can't be kept being  $T_0$  all the time due to the rounding dispersion, frequency drift and UE movement. A nominal time for reference of the first received DL DPCH, called DL DPCH nominal time, is defined as  $T_0$  before UE Tx time. UE monitors Rx-Tx time difference, and adjust UE Tx time to reduce the error between the first received finger and DL DPCH nominal time. For a new RL addition DL DPCH nominal time is used for the reference time of a new RL.

In the case of USTS mode UE Tx time is adjusted to keep uplink synchronized. Node B is responsible for the adjustment of the UE Tx time, that is called USTS tracking process. For example, as path delay gets longer, the arrival time of UL at UE will be delayed. Then Node B commands UE to adjust Tx time earlier to compensate for the increased path delay.

Rx-Tx timing relation in USTS mode is not same as in the normal mode. When  $T_{ref}$  is one-way maximum delay of cell, we can use the same reference time,  $T_{UE Tx} - T_0$ , in the USTS mode as we do in the normal mode. When  $T_{ref}$  is greater than 128 chips, a little performance degradation might be incurred and increase of UE complexity might be required. There is, however, no problem when  $T_{ref}$  is less than 128 chips, because the difference between Rx and Tx time lies in the range of normal mode.

$T_{ref}$  being 128 chips means that the radius of cell is 10km, which is large enough for indoor and pedestrian environment where USTS would be applicable. Therefore we can say that in the most cases there will be no problem regarding UE timing relations when we deal with reference time for a new RL at UE the way we do in the normal mode.

---

## 7 Impacts to other WGs

### 7.1 WG2

#### 7.1.1 RRC layer

RRC Connection Request Message needs to include **USTS indicator** to notify whether the UE supports USTS or not.

The following RRC messages should include some information related to USTS such as scrambling code, channelization code, and initial synchronization information.

- RRC Connection Setup Message,
- RRC Connection Request Message
- Radio Bearer Setup Message,
- Radio Bearer Reconfiguration Message
- Transport Channel Re-configuration
- Physical Channel Reconfiguration

#### 7.1.2 RLC Layer

- No impact on RLC layer

#### 7.1.3 MAC Layer

- No impact on MAC layer

#### 7.1.4 Interface between RRC and PHY layer

Inter-layer interface primitive between RRC layer and physical layer should include some parameters for USTS

- CPHY-RL-Modify-REQ
- CPHY-RL-Setup-REQ

## 7.2 WG3

Note: This part copied from the latest version of TR25.839.

### 7.2.1 New parameters

**Table 7.1 New paramters for USTS**

New parameters for USTS	Functions	Messages
<i>USTS Indicator</i>	To let Node B setup the radio link in USTS mode	<b>CRNC → Node B</b> <ul style="list-style-type: none"> <li>- RADIO LINK SETUP REQUEST</li> <li>- RADIO LINK RECONFIGURATION PREPARE</li> </ul>
	To let DRNC setup the radio link in USTS mode	<b>SRNC → DRNC</b> <ul style="list-style-type: none"> <li>- RADIO LINK SETUP REQUEST</li> <li>- RADIO LINK RECONFIGURATION PREPARE</li> </ul>
<i>USTS Support Indicator</i>	<i>To notify SRNC whether DRNC's Node B supports USTS or not</i>	<b>DRNC → SRNC</b> <ul style="list-style-type: none"> <li>- RADIO LINK SETUP RESPONSE</li> </ul>
$T_{INIT\_SYNC}$	To be calculated from $T_{ref}$ and Propagation Delay in SRNC	N/A
$T_{ref}$	To let Node B execute the tracking process with this	<b>CRNC → Node B</b> <ul style="list-style-type: none"> <li>- CELL SETUP REQUEST</li> <li>- CELL RECONFIGURATION REQUEST</li> </ul>
	To be given to DRNC as initial loading Data  To calculate $T_{INIT\_SYNC}$ in SRNC	<b>DRNC → SRNC</b> <ul style="list-style-type: none"> <li>- RADIO LINK SETUP RESPONSE</li> <li>- RADIO LINK RECONFIGURATION READY</li> </ul>

New parameters for USTS	Functions	Messages
<i>USTS Scrambling Code</i>	To let Node B know the scrambling code of UE	<b>CRNC → Node B</b> - RADIO LINK SETUP REQUEST
	To let DRNC know the scrambling code of UE (In case of handover)	<b>SRNC → DRNC</b> - RADIO LINK SETUP REQUEST - RADIO LINK ADDITION REQUEST
	To let SRNC know the scrambling code of UE assigned by DRNC	<b>DRNC → SRNC</b> - RADIO LINK SETUP RESPONSE - RADIO LINK RECONFIGURATION READY
<i>USTS Scrambling Code Offset</i>	To let Node B know the scrambling code Offset of UE (In case of handover)	<b>CRNC → Node B</b> RADIO LINK SETUP REQUEST
	To let DRNC know the scrambling code offset of UE (In case of handover)	<b>SRNC → DRNC</b> - RADIO LINK SETUP REQUEST - RADIO LINK ADDITION REQUEST
<i>USTS Channelisation Code Number</i>	To notify Node B of Channelisation Code information	<b>CRNC → Node B</b> - RADIO LINK SETUP REQUEST
	To let DRNC know the channelisation code information of UE (In case of handover)	<b>SRNC → DRNC</b> - RADIO LINK SETUP REQUEST
	To retrieve Channelisation Code for USTS	<b>DRNC → SRNC</b> - RADIO LINK SETUP RESPONSE - RADIO LINK RECONFIGURATION READY

## 7.2.2 Impacts on Interfaces

### 7.2.2.1 Iub Interface

To support USTS in Iub Interface, the followings will be done.

- To transmit the *USTS Indicator* from CRNC to Node B, *USTS Indicator* should be added in NBAP messages, **RADIO LINK SETUP REQUEST** and **RADIO LINK RECONFIGURATION PREPARE**.
- Through **CELL SETUP REQUEST** and **CELL RECONFIGURATION REQUEST**,  $T_{ref}$  will be sent to Node B from CRNC and will be used to execute the tracking process in Node B.
- *USTS Scrambling Code & USTS Scrambling Code Offset* will be sent to Node B from CRNC through **RADIO LINK SETUP REQUEST**.
- In NBAP messages, **RADIO LINK SETUP REQUEST**, *USTS Channelisation Code Number* should be added to retrieve USTS channelization code.

### 7.2.2.2 Iur Interface

To support USTS in Iur Interface, the followings will be done. And these are very similar to Iub's.

- SRNC should indicate to DRNC whether or not the UE is in USTS mode. Therefore, *USTS indicator* should be added in RNSAP messages, **RADIO LINK SETUP REQUEST** and **RADIO LINK RECONFIGURATION PREPARE**.
- To let SRNC know whether or not DRNC's Node B supports USTS, *USTS Support Indicator* should be added in RNSAP messages, **RADIO LINK SETUP RESPONSE (in neighbouring cell information)**.
- To transmit the  $T_{ref}$  of DRNC's node B to SRNC,  $T_{ref}$  should be added in RNSAP messages, **RADIO LINK SETUP RESPONSE** in the case of set up with USTS and **RADIO LINK RECONFIGURATION READY** in the case of mode change from non-USTS to USTS when USTS indicator has been received by DRNC.
- *USTS Scrambling Code* and *USTS Scrambling Code Offset* will be sent to DRNC from SRNC through **RADIO LINK SETUP REQUEST** and **RADIO LINK ADDITION REQUEST** in the case of handover
- To send the *USTS Scrambling Code* assigned by DRNC to SRNC, *USTS Scrambling Code* should be added in RNSAP messages, **RADIO LINK SETUP RESPONSE** and **RADIO LINK RECONFIGURATION READY**.
- *USTS Channelisation Code Number* will be sent to DRNC from SRNC through **RADIO LINK SETUP REQUEST** in the case of handover
- To send the *USTS Channelisation Code Number* assigned by DRNC to SRNC, this IE should be added in RNSAP messages, **RADIO LINK SETUP RESPONSE** and **RADIO LINK RECONFIGURATION READY**.

### 7.2.2.3 Iu Interface

No impacts on Iu Interface.

## 7.2.3 Procedures

### 7.2.3.1 Mode Change procedure

The radio link can be in one of the following three modes:

- Normal mode : No timing control, UE discrimination by scrambling code
- Non-USTS mode : No timing control, UE discriminated by both scrambling and channelisation codes

- USTS mode : Timing control, UE discriminated by both scrambling and channelisation codes

The difference between Normal mode and Non-USTS mode is as follows. If one of the radio links to the cell sites in Active set is in USTS mode, it is discriminated by both scrambling code and channelisation codes assigned for USTS mode in all cells in Active set. Therefore, the other links should be in non-USTS mode. This is because the UE has only a single transmitter and there can be more than one UEs who enter the SHO region from the same original cell and accordingly, they use the common scrambling code and the discrimination can be done only by channelisation codes. The UE in USTS mode has an USTS-mode RL and non-USTS mode RL(s). In normal mode, the UEs in SHO region use their own unique scrambling codes.

The Mode Change from USTS mode to normal mode will be executed before normal handover when the target DRNC's node B cannot support USTS. In this mode change, Both new scrambling and channelisation codes are allocated to perform normal handover. But if the target DRNC's node B can support USTS, Non-USTS mode to USTS mode change will be executed after normal handover procedure shown in Figure 7. 1. In this mode change, New parameter values such as scrambling code and channelisation code should be assigned to perform USTS. And the reverse mode change, from normal mode to USTS mode will be executed in case of RRC state change shown in Figure 7. 3.

In the last call flow (Inter RNS Handover procedure – Figure 7. 4), it will be shown how Mode Change can be applied to support soft handover with USTS technology.

The following is the procedure of Mode Change from Non-USTS to USTS mode. Mode Change will be executed after soft handover procedure. The scrambling and channelisation codes for USTS will be assigned to UE and UE will synchronize the timing with  $T_{INIT\_SYNC}$  which was calculated by SRNC. From Mode Change UE can get the timing control and the codes for USTS.

#### 1. RADIO LINK RECONFIGURATION PREPARE

This message transmits *USTS Indicator* to DRNC from SRNC. DRNC will be requested by SRNC whether or not the UE would be in USTS mode with *USTS Indicator*.

#### 2. RADIO LINK RECONFIGURATION PREPARE

This message sends USTS Indicator, USTS scrambling code and USTS Channelisation Code Number to Node B from DRNC.

#### 3. RADIO LINK RECONFIGURATION READY

NBAP Message **RADIO LINK RECONFIGURATION READY** is sent from DRNC's Node B to DRNC.

#### 4. RADIO LINK RECONFIGURATION READY

This message transmits  $T_{ref}$ , *USTS scrambling code* and *USTS Channelisation Code Number* to SRNC from DRNC.

#### 5. RADIO LINK RECONFIGURATION COMMIT

RNSAP Message **RADIO LINK RECONFIGURATION COMMIT** is sent from SRNC to DRNC.

#### 6. RADIO LINK RECONFIGURATION COMMIT

NBAP Message **RADIO LINK RECONFIGURATION COMMIT** is sent from DRNC to Node B.

#### 7. PHYSICAL CHANNEL RECONFIGURATION

SRNC sends RRC message PHYSICAL CHANNEL RECONFIGURATION to UE.

#### 8. Actualizing modification

Both UE and Node B actualise modification of the physical channel.

#### 9. PHYSICAL CHANNEL RECONFIGURATION COMPLETE

UE sends RRC message PHYSICAL CHANNEL RECONFIGURATION COMPLETE to SRNC.

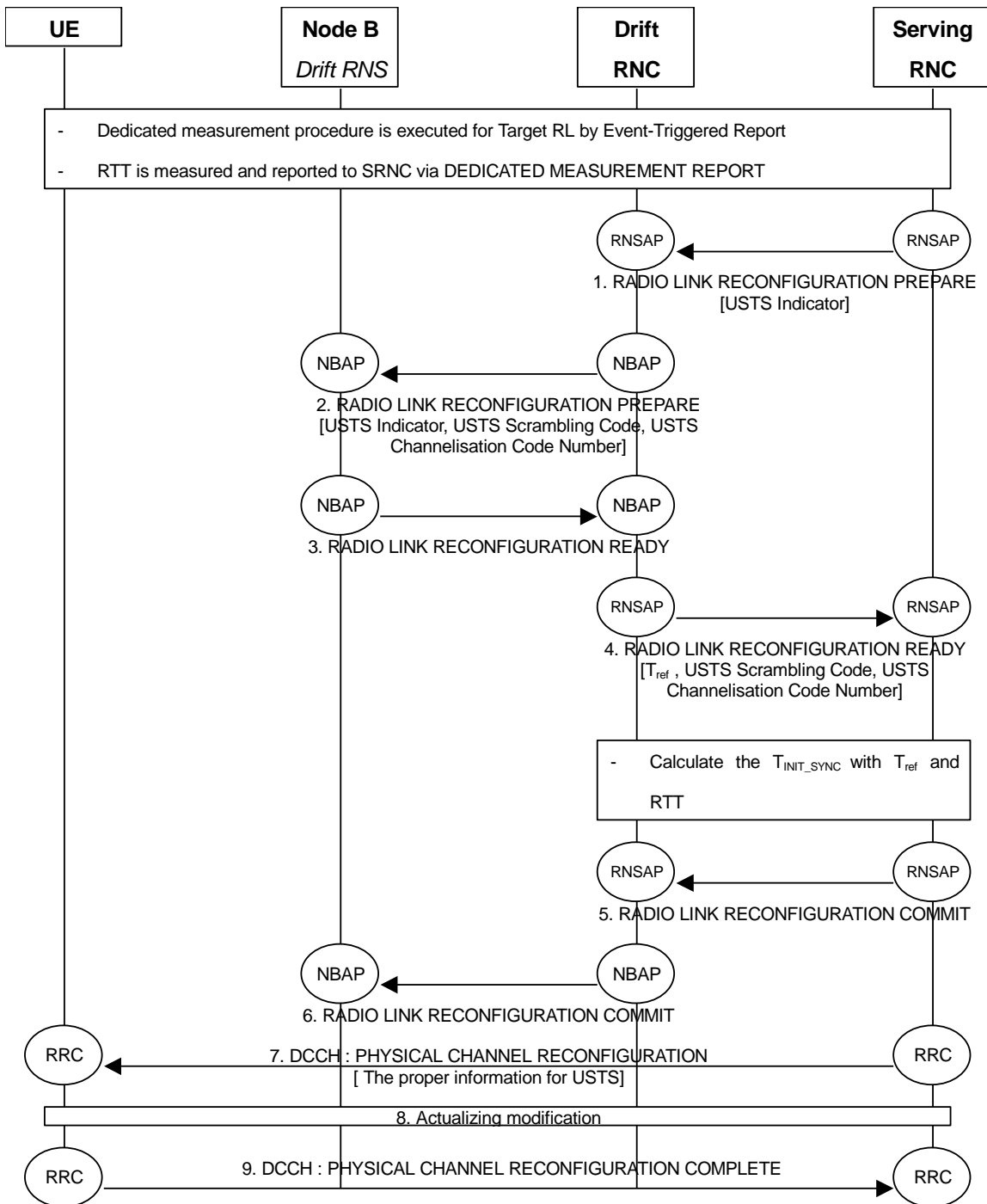

Figure 7. 1 MODE CHANGE procedure

## 7.2.4 Call flows of USTS

The following are call flows for USTS. The first one is for basic call that Iur Interface is not necessary, and the second is for the call which needs Iur Interface because of RRC State Change. And the last one is for the call which have to use Iur Interface because of Inter RNS handover.

### 7.2.4.1 Call Setup

This is the basic call procedure for USTS. In this scenario, Iur Interface is not necessary. So SRNC and CRNC are same.



1. RRC CONNECTION REQUEST

UE sends RRC message **RRC CONNECTION REQUEST** to SRNC.

2. RADIO LINK SETUP REQUEST

This message transmits USTS Indicator, USTS Scrambling Code, and USTS Channelisation Code Number to the Node B.

3. RADIO LINK SETUP RESPONSE

Node B allocates resources, starts PHY reception, and responses with NBAP message **RADIO LINK SETUP RESPONSE**.

4. ALCAP Iub Data Transport Bearer Setup

SRNC initiates set-up of Iub Data Transport bearer using ALCAP protocol. This request contains the AAL2 Binding Identity to bind the Iub Data Transport Bearer to the DCH. The request for set-up of Iub Data Transport bearer is acknowledged by Node B.

5. User Plane Synchronisation

The Node B and SRNC establish synchronism for the Iub and Iur Data Transport Bearer by means of exchange of the appropriate DCH Frame Protocol frames.

6. RRC CONNECTION SETUP

SRNC sends RRC message **RRC CONNECTION SETUP** to UE.

7. RRC CONNECTION COMPLETE

UE sends RRC message **RRC CONNECTION COMPLETE** to SRNC.

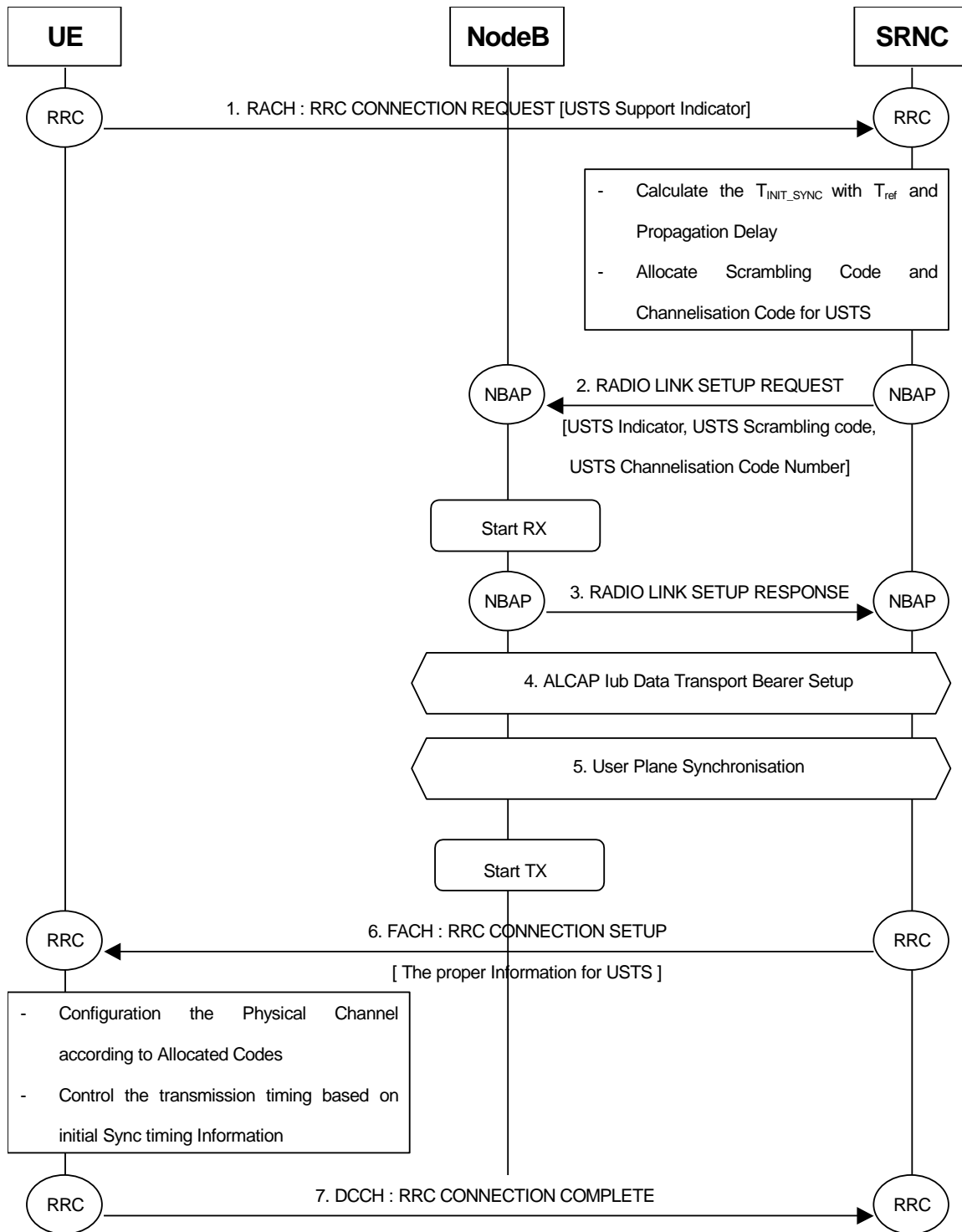

Figure 7. 2 Call Flow of USTS without Iur Interface

### 7.2.4.2 Channel and Mobile State Change

Regarding to RRC state changes which gives some impacts on procedures for USTS, Two cases could be considered. One is the transition from CELL\_DCH to CELL\_FACH state, which might occur when all dedicated channels have been released via explicit signalling (e.g. PHYSICAL CHANNEL RECONFIGURATION, RADIO BEARER RECONFIGURATION, RADIO BEARER RELEASE, RADIO BEARER SETUP, TRANSPORT CHANNEL RECONFIGURATION, etc.). The other case is the transition from CELL\_FACH to CELL\_DCH state, which might occur, when a dedicated physical channel is established via explicit signalling (e.g. PHYSICAL CHANNEL

RECONFIGURATION, RADIO BEARER RECONFIGURATION, RADIO BEARER RELEASE, RADIO BEARER SETUP, RRC CONNECTION REESTABLISHMENT, TRANSPORT CHANNEL RECONFIGURATION, etc.).

### 1) Transition from CELL\_DCH to CELL\_FACH state

Since there exists no more dedicated channel in this case, No additional procedures are required

### 2) Transition from CELL\_FACH to CELL\_DCH state

In this case, dedicated channel is established by explicit signalling. New parameters for USTS should be added to the messages in the process of state transition, which follows Mode Change procedure described above. When this transition is associated with handover, call flow for USTS is illustrated in Figure 7. 3.

This is the call procedure for USTS which needs Iur Interface because of RRC state change. In this scenario, Iur Interface should be considered. So the impact of RNC will be described in the point of SRNC's and DRNC's.

SRNC decides to switch to CELL\_DCH state, setting up a new radio link via a new cell controlled by DRNC.

#### 1. RADIO LINK SETUP REQUEST

This message transmits *USTS Indicator* to DRNC from SRNC. DRNC will be known whether or not the UE will be in USTS mode with *USTS Indicator*.

#### 2. RADIO LINK SETUP REQUEST

This message transmits *USTS Indicator*,  $T_{ref}$ , *USTS scrambling code*, and *USTS Channelisation Code Number* to Node-B from DRNC.

#### 3. RADIO LINK SETUP RESPONSE

Node B allocates resources, starts PHY reception, and responses with NBAP message **RADIO LINK SETUP RESPONSE**.

#### 4. RADIO LINK SETUP RESPONSE

This message sends USTS Support Indicator,  $T_{ref}$ , USTS scrambling code and USTS Channelisation Code Number to SRNC from DRNC.

#### 5. ALCAP Iub Bearer Setup & ALCAP Iur Bearer Setup

SRNC initiates setup of Iur, while DRNC is in charge to setup Iub, Data Transport Bearer using ALCAP protocol. This request contains the AAL2 Binding Identity to bind the Iub Data Transport Bearer to DCH. Note: there is not a time relation between set up of Iur and Iub. Both must be carried out before next step.

#### 6. User Plane Synchronisation

Node B and SRNC establish synchronism for the Data Transport Bearer by means of exchange of the appropriate DCH Frame Protocol frames.

#### 7. RADIO BEARER SETUP

SRNC sends RRC message **RADIO BEARER SETUP** to UE.

#### 8. Actualizing modification

Both UE and Node B actualise modification of the physical channel.

#### 9. RADIO BEARER SETUP COMPLETE

UE sends RRC message **RADIO BEARER SETUP COMPLETE** to SRNC.

#### 10. Common Transport Channel Resources Release

The SRNC releases the UE context for CELL\_FACH state in the source DRNC by sending a **Common Transport Channel Resources Release** message.

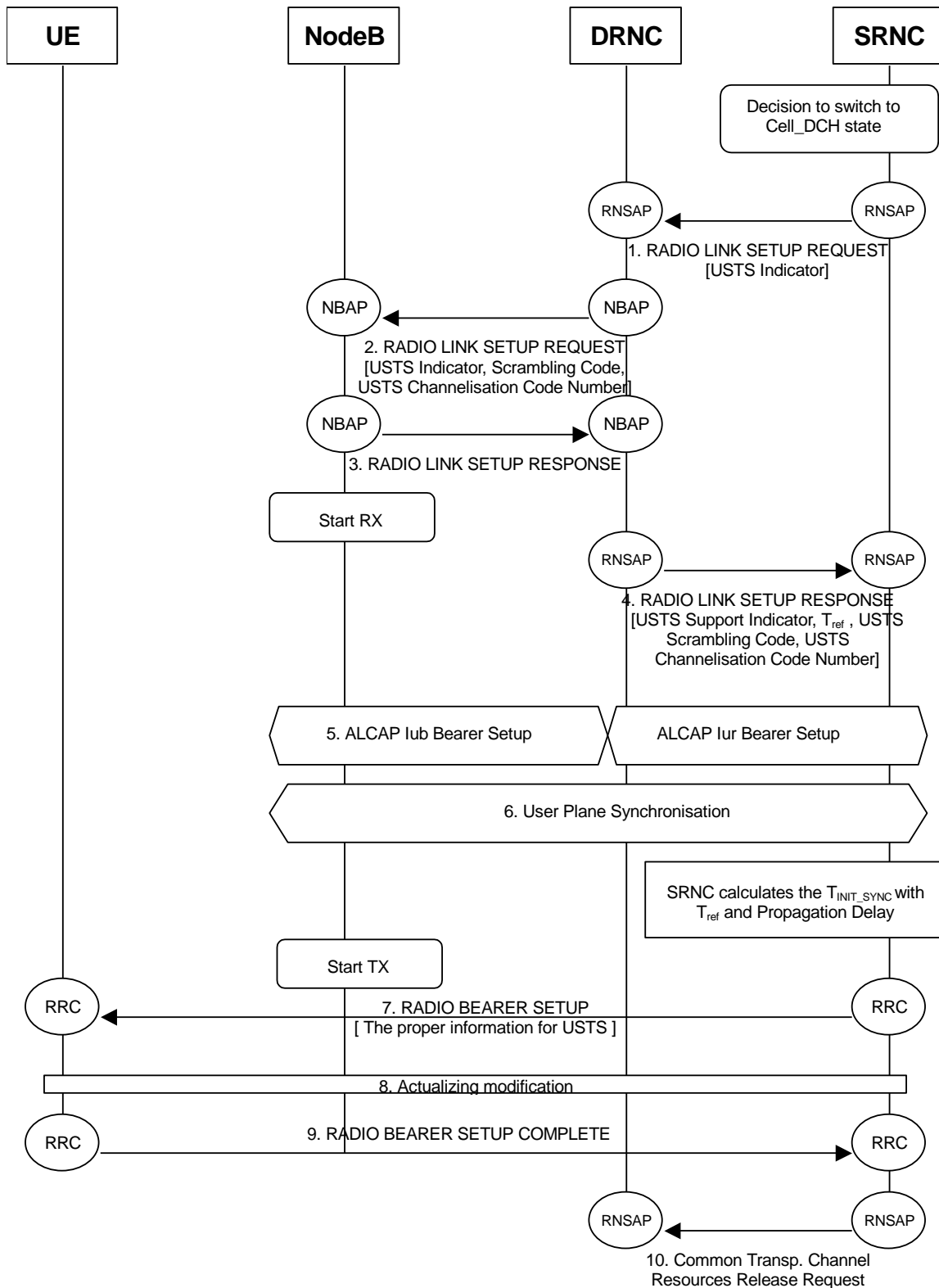

Figure 7. 3 Call flow for State Switching from CELL\_FACH to CELL\_DCH

7.2.4.3 Soft Handover

Detailed description on handover in USTS mode is included in WG1's TR[10]. Making a summary of the TR, the UE maintains an USTS mode RL while it is within USTS supporting Node B area. When it moves from the area to other USTS supporting Node B area, non-USTS mode RLs are added or deleted according to the movement of UE. After the

USTS mode RL is deleted, the UE continues to communicate with the remaining non-USTS mode RLs. When only a single RL remains, the mode change procedure is performed to switch the mode of the RL to USTS mode. This candidate for handover procedure imposes a minimal impact on the network side by eliminating the necessity of performing mode change for one of the RLs in Active set and proper RL reconfigurations for the other RLs at the same time.

This subclause presents the following soft handover procedures

- Radio Link Addition (Branch Addition)
  - Radio Link Deletion (Branch Deletion)
- 1) Radio Link Addition (Branch Addition)

Figure 7. 4 shows the procedure of Radio Link Addition (Branch Addition)

1. RADIO LINK SETUP REQUEST

This message transmits *USTS Indicator* to DRNC from SRNC. DRNC will be known whether or not the UE will be in USTS mode with *USTS Indicator*.

2. RADIO LINK SETUP REQUEST

This message transmits *USTS Indicator*,  $T_{ref}$ , *USTS scrambling code*, and *USTS Channelisation Code Number* to Node-B from DRNC.

3. RADIO LINK SETUP RESPONSE

Node B allocates resources, starts PHY reception, and responses with NBAP message **RADIO LINK SETUP RESPONSE**.

4. RADIO LINK SETUP RESPONSE

This message sends USTS Support Indicator,  $T_{ref}$ , USTS scrambling code and USTS Channelisation Code Number to SRNC from DRNC.

5. ALCAP Iub/Iur Data Bearer Setup

SRNC initiates set-up of Iub/Iur Data Transport bearer using ALCAP protocol. This request contains the AAL2 Binding Identity to bind the Iub Data Transport Bearer to the DCH.

6. User Plane Synchronisation

Node B and SRNC establish synchronism for the Data Transport Bearer by means of exchange of the appropriate DCH Frame Protocol frames.

7. ACTIVE SET UPDATE

SRNC sends RRC Message **ACTIVE SET UPDATE** to UE on DCCH

8. ACTIVE SET UPDATE COMPLETE

UE acknowledges with RRC message **ACTIVE SET UPDATE COMPLETE**

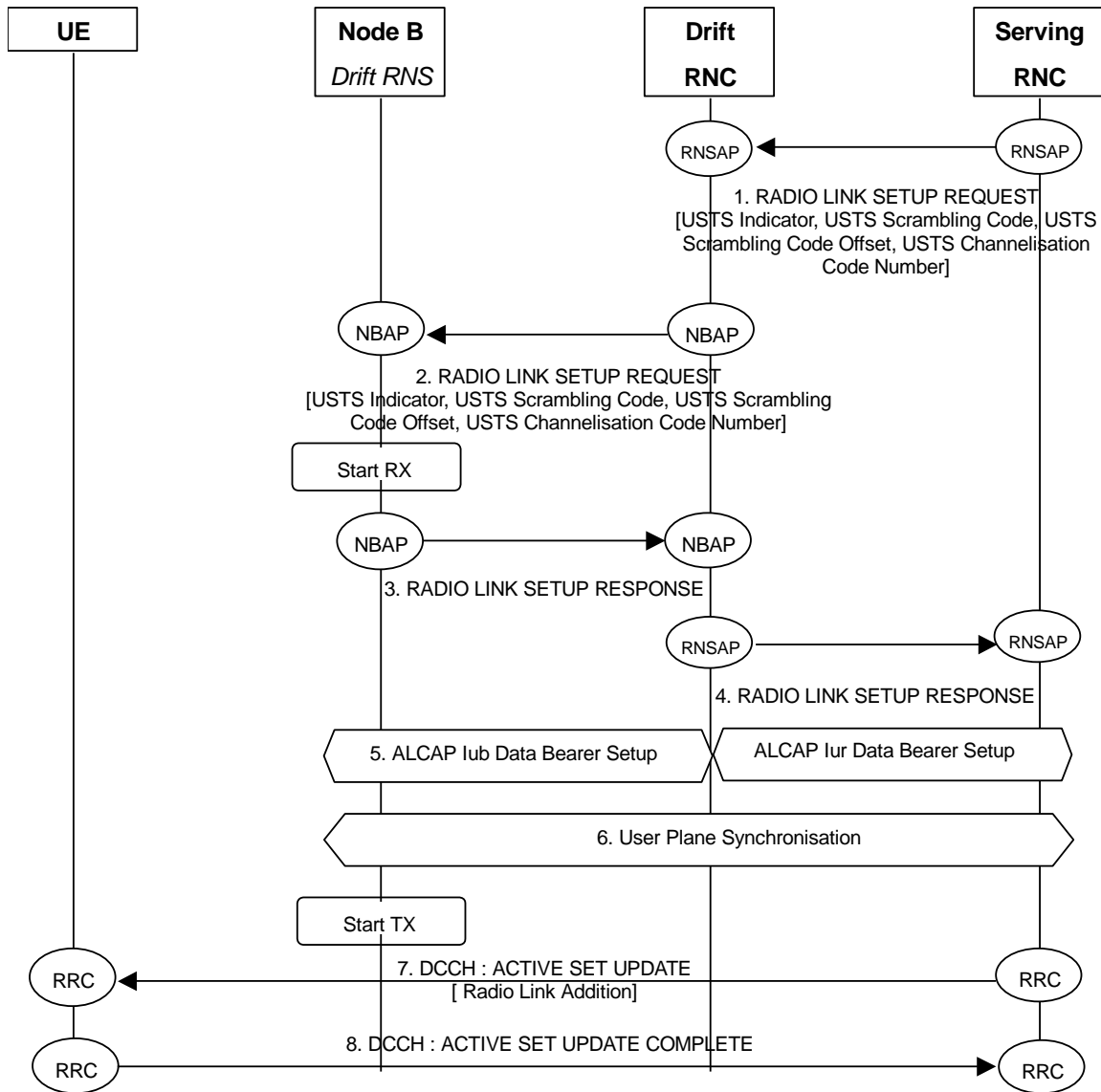

**Figure 7. 4 Radio Link Addition (Branch Addition)**

2) Radio Link Deletion (Branch Deletion)

This procedure is the same as normal RL deletion procedure.

**7.3 WG4**

FFS

**8 Backward compatibility**

Since the USTS capability is negotiated during call-setup phase, a UE based on Release 99/4 can be used in Release 5 UTRAN with USTS capability without any impact. And similarly, a UE based on Release 5 with USTS capability can be used in Release 99/4 UTRAN without any impact by the same reason.

Consequently, the backward compatibility is guaranteed with USTS in Release 5.

---

## Annex A: Change history

Change history							
Date	TSG #	TSG Doc.	CR	Rev	Subject/Comment	Old	New
14/12/02	RAN_14	RP-010826			Approved at TSG RAN #14 and placed under Change Control	-	5.0.0