

# 3GPP TS 25.467 V11.4.0 (2013-09)

---

*Technical Specification*

**3rd Generation Partnership Project;  
Technical Specification Group Radio Access Network;  
UTRAN architecture for 3G Home Node B (HNB);  
Stage 2  
(Release 11)**



The present document has been developed within the 3<sup>rd</sup> Generation Partnership Project (3GPP™) and may be further elaborated for the purposes of 3GPP. The present document has not been subject to any approval process by the 3GPP Organizational Partners and shall not be implemented. This Specification is provided for future development work within 3GPP only. The Organizational Partners accept no liability for any use of this Specification. Specifications and reports for implementation of the 3GPP™ system should be obtained via the 3GPP Organizational Partners' Publications Offices.

---

---

**Keywords**

UMTS, radio, architecture

**3GPP**

---

**Postal address**

---

**3GPP support office address**

---

650 Route des Lucioles - Sophia Antipolis  
Valbonne - FRANCE  
Tel.: +33 4 92 94 42 00 Fax: +33 4 93 65 47 16

---

**Internet**

<http://www.3gpp.org>

---

**Copyright Notification**

---

No part may be reproduced except as authorized by written permission.  
The copyright and the foregoing restriction extend to reproduction in all media.

© 2013, 3GPP Organizational Partners (ARIB, ATIS, CCSA, ETSI, TTA, TTC).  
All rights reserved.

UMTS™ is a Trade Mark of ETSI registered for the benefit of its members  
3GPP™ is a Trade Mark of ETSI registered for the benefit of its Members and of the 3GPP Organizational Partners  
LTE™ is a Trade Mark of ETSI currently being registered for the benefit of its Members and of the 3GPP Organizational Partners  
GSM® and the GSM logo are registered and owned by the GSM Association

# Contents

Foreword .....	6
1 Scope .....	7
2 References.....	7
3 Definitions, symbols and abbreviations .....	8
3.1 Definitions .....	8
3.2 Abbreviations.....	9
4 Overall architecture .....	10
4.1 General .....	10
4.1.1 HNB Management System (HMS) .....	11
4.1.2 Security Gateway (SeGW) .....	11
4.1.3 HNB Gateway (HNB-GW) .....	11
4.1.4 HNB.....	12
4.1.5 L-GW .....	12
4.2 Functional split.....	12
5 UTRAN functions for HNB access.....	14
5.1 UE Registration.....	14
5.1.1 General.....	14
5.1.2 UE Registration: case of non CSG UEs or non CSG HNBs .....	15
5.1.3 UE Registration: case of CSG UEs and CSG or Hybrid HNBs .....	16
5.1.4 HNB-GW triggered UE Registration.....	17
5.1.5 UE Registration: case of Open Access HNBs .....	19
5.2 HNB Registration .....	20
5.2.1 General .....	20
5.2.2 HNB Registration procedure.....	20
5.3 HNB-GW Discovery Function.....	21
5.3.1 General.....	21
5.4 HNB de-registration Function .....	21
5.4.1 General.....	21
5.5 Iuh Disconnect .....	21
5.5.1 General .....	21
5.5.2 Iuh Disconnect procedure .....	22
5.6 Paging Optimization Function .....	23
5.6.1 General .....	23
5.7 HNB to HNB Mobility .....	23
5.7.1 General .....	23
5.7.2 Connected mode mobility from one HNB to another HNB (Intra PLMN, Intra HNB-GW, Intra CSG).....	23
5.7.2.1 C-Plane Handling.....	23
5.7.2.2 User Plane Handling.....	25
5.7.3 Soft Handover Initiation.....	26
5.7.4 Mobility Access Control.....	27
5.7.4.1 Limitations .....	27
5.8 HNB Configuration Transfer .....	27
5.9 Iurh Setup.....	28
5.9.1 General .....	28
5.9.2 Iurh Setup for direct Iurh connectivity between HNBs .....	29
5.9.3 Iurh Setup for Iurh connectivity between HNBs via the HNB-GW .....	29
5.9.4 Iurh Setup between the HNB and the HNB-GW for HNB-RNC connectivity .....	30
5.10 Handling of Source information transfer to Target .....	30
5.10.1 RAB Related Parameters .....	31
5.10.1.1 User Plane .....	31
5.10.1.2 Other parameters .....	31
5.10.2 Non-RAB Related Parameters .....	31
5.8a CS user plane multiplexing .....	31

5.9a	Inbound Mobility to HNB .....	31
5.9.1a	General .....	31
5.9.2a	Connected Mode Inbound Mobility for CSG UEs to CSG HNBs or to Hybrid Cells .....	31
5.9.3a	Connected Mode Inbound Mobility for non-CSG UEs to CSG HNBs or to Hybrid Cells .....	33
5.9.4a	Connected Mode Inbound Mobility to open access HNBs .....	35
5.10a	CSG Subscription Expiry .....	36
5.11	Connectivity between HNB and RNC via HNB-GW for RNSAP signalling .....	36
5.11.1	General .....	36
5.11.2	Enhanced Relocation between HNB and RNC via HNB-GW .....	36
5.11.2.1	Enhanced Relocation from Open Access and Hybrid HNBs to RNC .....	36
5.11.2.2	Enhanced Relocation from RNC to Open Access HNBs for CSG UEs .....	37
5.11.2.3	Enhanced Relocation from RNC to Hybrid HNB for CSG UEs .....	39
5.11.3	Soft Handover between HNB and RNC via HNB-GW .....	41
5.11.3.1	Soft Handover from HNB to RNC .....	41
5.11.3.2	Soft Handover from RNC to Open or Hybrid Access HNB .....	42
5.12	Fixed Broadband Access network Interworking .....	43
6	Requirements for O&M .....	44
6.1	O&M for HNB .....	44
6.1.1	Provisioning Procedure for HNB .....	44
6.1.2	Location Verification .....	44
6.1.2.1	General .....	44
6.1.2.2	Macro-cell Information .....	44
6.1.2.2.1	General .....	44
6.1.2.2.2	UTRAN Cell Information .....	45
6.1.2.2.3	GSM Cell Information .....	45
6.1.2.3	GNSS Location Information .....	46
6.1.2.4	Broadband Connection Information .....	46
6.1.3	HNB-GW Discovery .....	46
6.1.4	HNB Provisioning .....	46
6.1.4.1	General .....	46
6.1.4.2	CN Level Parameters .....	47
6.1.4.3	RAN Level Parameters .....	48
6.1.4.4	RF Level Parameters .....	50
6.2	O&M for HNB-GW .....	50
7	Iurh interface protocol structure .....	51
7.1	General .....	51
7.2	Iurh .....	51
7.3	Iurh .....	52
7.3.1	Iurh-Interface Control Plane Protocol Stack .....	53
7.3.2	Usage of the services provided by RNSAP User Adaptation Layer (RNA) .....	54
7.3.2.1	General .....	54
7.3.2.2	Iurh Signalling Connection Establishment .....	55
7.3.2.2.1	Direct Iurh connectivity .....	55
7.3.2.2.2	Iurh signalling connection establishment via the HNB-GW .....	55
7.3.2.3	Transport of RNSAP signalling messages via an established Iurh signalling connection .....	56
7.3.2.3.1	Direct Iurh connectivity .....	56
7.3.2.3.2	Iurh connectivity via the HNB-GW .....	56
7.3.2.4	Release of a Signalling Connection .....	56
7.3.2.4.1	Direct Iurh connectivity .....	56
7.3.2.4.2	Iurh connectivity via the HNB-GW .....	57
7.3.2.5	Transport of RNSAP signalling messages via the connectionless data transfer service .....	57
7.3.2.5.1	Direct Iurh connectivity .....	57
7.3.2.5.2	Iurh connectivity via the HNB-GW .....	57
7.3.3	Interworking between the RNSAP User Adaptation Layer (RNA) and the Signalling Connection Control Part (SCCP) .....	58
7.3.3.1	General .....	58
7.3.3.2	Establishment of signalling connection over Iurh and Iur connections between HNB and RNC via HNB-GW .....	59
7.3.3.2.1	HNB initiated .....	59
7.3.3.2.2	HNB initiated – Refusal from RNC .....	60

7.3.3.2.3	RNC initiated .....	61
7.3.3.3	Transport of RNSAP signalling messages via signalling connection established over Iurh and Iur connections .....	62
7.3.3.3.1	HNB initiated .....	62
7.3.3.3.2	RNC initiated .....	62
7.3.3.4	Release of signalling connection over Iurh and Iur Connections .....	63
7.3.3.4.1	HNB initiated .....	63
7.3.3.4.2	RNC initiated .....	63
7.3.3.5	Transport of RNSAP signalling messages via the connectionless data transfer service .....	64
7.3.3.5.1	HNB initiated .....	64
7.3.3.5.2	RNC initiated .....	64
8	Enhanced Interference Management .....	65
8.1	General .....	65
8.2	Mitigation of interference from HNB to Macro .....	65
8.2.1	Interference from HNB UE (UL) to Macro NB .....	65
8.2.2	Interference from HNB (DL) to Macro UE .....	65
<b>Annex A (informative):</b>	<b>Implementation of CN functions within the HNB-GW for support of inter-HNB intra-HNB-GW SRNS Relocation .....</b>	<b>66</b>
A.1	Scope .....	66
A.2	General .....	66
A.3	Mobility procedure .....	66
A.4	Iurh Control Plane Aspects .....	68
A.5	Iurh user plane aspects .....	68
A.6	RAB management Functions .....	68
A.7	Data Volume Reporting .....	68
A.8	UE Tracing .....	68
A.9	Location reporting function .....	69
A.10	Security Functions .....	69
A.11	Iurh Framing Protocol Interworking Function (IurhUPIF) .....	69
A.11.1	Introduction .....	69
A.11.2	CS User Plane handling during the Initial CS RAB setup .....	70
A.11.3	CS User Plane handling after the finalisation of SRNS Relocation .....	70
A.11.4	FQC .....	71
A.11.5	Frame number .....	71
A.11.6	Time alignment Procedure: .....	71
A.11.7	Rate Control Procedure .....	71
A.11.8	Payload .....	72
A.11.9	Iurh UP Re-Initialisation .....	72
<b>Annex B (informative):</b>	<b>Deployment Architecture .....</b>	<b>73</b>
B.1	Direct Iurh connectivity between HNBs .....	73
<b>Annex C (informative):</b>	<b>Implementation of PSC Disambiguation for Support of Legacy UE Mobility from RNC to HNB .....</b>	<b>75</b>
C.1	Scope .....	75
C.2	Disambiguation at the RNC .....	75
C.2.1	Step 1: Construction of HNB database in the RNC .....	75
C.2.2	Step 2: PSC disambiguation executed by the RNC during RNC to HNB hand-in .....	76
C.3	Disambiguation at the HNB-GW .....	76
C.3.1	Construction and Update of $\Delta$ OTD Database at the HNB-GW .....	77
C.3.2	Target Cell Disambiguation for Handover to the HNB .....	77
C.4	Notes .....	77
<b>Annex D (informative):</b>	<b>Change History .....</b>	<b>79</b>

---

## Foreword

This Technical Specification has been produced by the 3<sup>rd</sup> Generation Partnership Project (3GPP).

The contents of the present document are subject to continuing work within the TSG and may change following formal TSG approval. Should the TSG modify the contents of the present document, it will be re-released by the TSG with an identifying change of release date and an increase in version number as follows:

Version x.y.z

where:

- x the first digit:
  - 1 presented to TSG for information;
  - 2 presented to TSG for approval;
  - 3 or greater indicates TSG approved document under change control.
- y the second digit is incremented for all changes of substance, i.e. technical enhancements, corrections, updates, etc.
- z the third digit is incremented when editorial only changes have been incorporated in the document.

---

# 1 Scope

The present document specifies the UTRAN architecture for 3G Home NodeB (HNB).

It covers specification of the functions for UEs not supporting Closed Subscriber Groups (CS G) and UEs supporting CSGs. It also covers HNB specific requirements for O&M.

---

# 2 References

The following documents contain provisions which, through reference in this text, constitute provisions of the present document.

- References are either specific (identified by date of publication, edition number, version number, etc.) or non-specific.
- For a specific reference, subsequent revisions do not apply.
- For a non-specific reference, the latest version applies. In the case of a reference to a 3GPP document (including a GSM document), a non-specific reference implicitly refers to the latest version of that document *in the same Release as the present document*.

- [1] 3GPP TR 21.905: "Vocabulary for 3GPP Specifications".
- [2] 3GPP TS 25.468: "UTRAN Iuh Interface RUA signalling".
- [3] 3GPP TS 25.469: "UTRAN Iuh Interface HNBAP signalling".
- [4] 3GPP TS 25.401: "UTRAN overall description".
- [5] 3GPP TS 25.410: "UTRAN Iu Interface: general aspects and principles".
- [6] IETF RFC 4960 (September 2007): "Stream Control Transmission Protocol".
- [7] Broadband Forum TR-069 Amendment 2, *CPE WAN Management Protocol*, Broadband Forum Technical Report, 2007.
- [8] 3GPP TS 25.444: "Iuh data transport and transport signalling".
- [9] 3GPP TS 25.413: "UTRAN Iu Interface RANAP Signalling".
- [10] 3GPP TS 23.060: "General Packet Radio Service (GPRS); Service Description; Stage 2".
- [11] 3GPP TS 22.220: "Service requirements for Home NodeBs and Home eNodeBs".
- [12] 3GPP TS 25.419: "UTRAN Iu Interface: Service Area Broadcast Protocol SABP".
- [13] Void
- [14] Void
- [15] Void
- [16] 3GPP TS 33.320: "Security of Home Node B (HNB) / Home evolved Node B (HeNB)".
- [17] 3GPP TS 25.415: "UTRAN Iu Interface user plane protocols".
- [18] 3GPP TS 25.423: "UTRAN Iur interface Radio Network Subsystem Application Part (RNSAP) Signalling".
- [19] 3GPP TS 25.471: "UTRAN Iurh Interface RNSAP User Adaptation (RNA) signalling".
- [20] Void

- [21] 3GPP TS 25.425: "UTRAN Iur interface user plane protocols for Common Transport Channel data streams".
- [22] 3GPP TS 25.427: "UTRAN Iub/Iur interface user plane protocol for DCH data streams".
- [23] 3GPP TS 25.104: "Base Station (BS) radio transmission and reception (FDD)".
- [24] 3GPP TS 32.642: "Telecommunication management; Configuration Management (CM); UTRAN network resources Integration Reference Point (IRP); Network Resource Model (NRM)".
- [25] 3GPP TS 25.331: "Radio Resource Control (RRC); Protocol specification".
- [26] 3GPP TS 24.008: "Mobile radio interface Layer 3 specification; Core network protocols; Stage 3".
- [27] 3GPP TS 32.652: "Telecommunication management; Configuration Management (CM); GERAN network resources Integration Reference Point (IRP); Network Resource Model (NRM)".
- [28] 3GPP TS 25.101: "User Equipment (UE) radio transmission and reception (FDD)".
- [29] 3GPP TS 25.304: "User Equipment (UE) procedures in idle mode and procedures for cell reselection in connected mode".
- [30] Void
- [31] 3GPP TS 25.420: "UTRAN Iur interface general aspects and principles".
- [32] ITU-T Recommendation Q.711 (1996-07): "Functional description of the signalling connection control part".
- [33] ITU-T Recommendation Q.712 (1996-07): "Definition and function of signalling connection control part messages".
- [34] ITU-T Recommendation Q.713 (1996-07): "Signalling connection control part formats and codes".
- [35] ITU-T Recommendation Q.714 (1996-07): "Signalling connection control part procedures".
- [36] 3GPP TS 23.139: "3GPP system – fixed broadband access network interworking".

---

## 3 Definitions, symbols and abbreviations

### 3.1 Definitions

For the purposes of the present document, the terms and definitions given in TR 21.905 [1] and the following apply. A term defined in the present document takes precedence over the definition of the same term, if any, in TR 21.905 [1].

**HNB, Home NodeB, 3G Home NodeB:** as defined in TS 22.220 [11]. These terms, their derivations and abbreviations are used synonymously throughout this document.

**CSG HNB:** A HNB that serves a CSG Cell, broadcasting a CSG Indicator and a specific CSG identity.

**Non CSG HNB:** A HNB that serves a cell which neither broadcasts a CSG Indicator nor a CSG Identity.

**Hybrid HNB:** A HNB that serves a hybrid cell not broadcasting a CSG Indicator but broadcasting a CSG identity.

**Membership Verification:** The process that checks whether a UE is a member or non-member of a hybrid cell.

**Access Control:** The process that checks whether a UE is allowed to access and to be granted services in a closed cell.

**CSG ID Validation:** The process that checks whether the CSG ID sent via relocation messages is the same as the one supported by the target RAN.

**RNSAP Relocation:** denotes enhanced mobility for inter-HNB Relocation via RNSAP. In this version of the specification, RNSAP Relocation is only defined for intra-PLMN intra-HNB-GW intra-CSG scenarios.



## 3.2 Abbreviations

For the purposes of the present document, the abbreviations given in TR 21.905 [1] and the following apply. An abbreviation defined in the present document takes precedence over the definition of the same abbreviation, if any, in TR 21.905 [1].

CS	Circuit Switched
CSG	Closed Subscriber Group
DSL	Digital Subscriber Line
DSL-GW	DSL GateWay
GNSS	Global Navigation Satellite System
GPS	Global Positioning System
HMS	Home NodeB Management System
HNB	3G Home NodeB
HNB-GW	3G HNB Gateway
HW	Hard Ware
IP	Internet Protocol
L-GW	Local GateWay
LAC	Local Area Code
LIPA	Local IP Access
PCRF	Policy and Charging Rules Function
RAC	Routing Area Code
RGW	Residential GateWay
SAC	Service Area Code
SCCP	Signalling Connection Control Part
SeGW	Security GateWay
SGW	Serving GateWay
SW	SoftWare

## 4 Overall architecture

### 4.1 General

The overall UMTS architecture and UTRAN architectures are described in TS 25.401 [4] and TS 25.410 [5]. For clarity and ease of understanding, at appropriate places references to TR-069 [7] and associated methods are described briefly although they are beyond the scope of this specification.

The reference model shown in Figure 4.1-1 below contains the network elements that make up the HNB access network. There is a one-to-many relationship between a HNB-GW and the HNB(s) it serves.

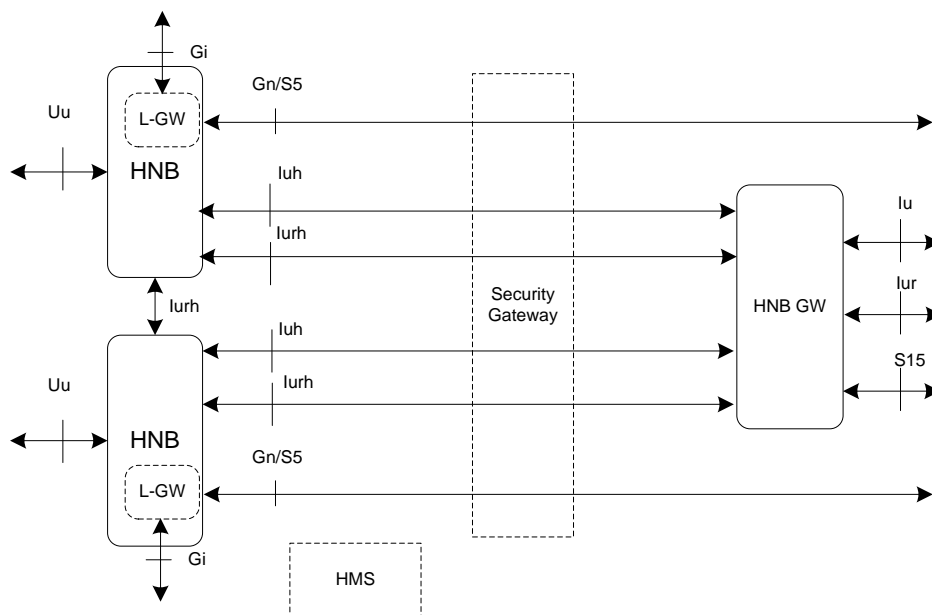

**Figure 4.1-1. HNB access network reference model.**

The HNB-GW appears to the CN as an RNC and serves as a concentrator of HNB connections. The Iu interface between the CN and the HNB-GW serves the same purpose as the interface between the CN and a RNC. The HNB GW is uniquely identified towards the CN on a particular Iu interface by the RNC ID. One HNB serves only one cell.

The HNB-GW appears to other RNCs as an RNC and serves as a concentrator of HNB connections. The HNB GW is uniquely identified towards the RNC on a particular Iur interface by the RNC ID.

The Local Gateway (L-GW) may be present only when the HNB operates in LIPA mode. When present, it is co-located with the HNB, in which case the HNB has a Gn/S5 interface towards the SGSN/SGW which does not use the HNB-GW, and a Gi interface towards the residential/IP network.

If the L-GW is present within the HNB, the HNB shall use for Gn/S5 connectivity the same secure interface established by the HNB for Iuh signalling as specified in TS 33.320 [16].

If the HNB-GW is supporting Fixed Broadband Access network interworking function, the HNB-GW uses a S15 interface towards PCRF for CS sessions as specified in TS 23.139 [36].

The HNB may be assigned the same inner IP address for the Gn/S5 interfaces as for the Iuh interface, or a different IP address.

**NOTE:** If the HNB uses the same IP address for Gn/S5 and the Iuh interface, they should be assigned distinct ranges of TEIDs in order to be able to discriminate downlink GTP-U packets.

NOTE: The Security gateway is a logically separated entity and may be implemented either as a separate physical element or integrated into, for example, a HNB-GW.

The HNB access network includes the functional entities as shown in Figure 4.1-1 and detailed below.

The HNB access network supports Iurh connectivity between HNBs and connectivity between HNBs and RNCs via the HNB-GW.

This version of specification supports three different Iurh connectivity options:

- Option1: Direct Iurh interface connectivity between the two involved HNBs.  
In this case the HNB-GW is not involved at all in Iurh RNL signalling.
- Option 2: Iurh interface connectivity between HNBs with the HNB-GW serving as an Iurh proxy.  
In this case the HNB-GW, acting as an Iurh-proxy, appears to a HNB as the peer HNB.  
For this connectivity option the role of the HNB-GW is transparent with regard to RNSAP signalling. Conveying respective signalling messages via the HNB-GW is performed by routing based on information provided by the RNSAP User Adaptation (RNA) layer, see TS 25.471 [19].
- Option 3: Iurh interface connectivity between HNBs and the HNB-GW utilised for transporting RNL signalling between those HNBs and RNCs via the HNB-GW.

NOTE: If Option 2 and Option 3 coexist, they share the same SCTP association.

Iurh connectivity between one pair of HNBs shall either support direct Iurh connectivity or Iurh connectivity via the HNB-GW, not both at the same time.

With respect to HNB-HNB mobility, there is no requirement for a HNB to support direct Iurh connectivity and Iurh connectivity via the HNB-GW at the same time in the current release of the specification.

### 4.1.1 HNB Management System (HMS)

The HMS:

- is based on the TR-069 family of standards [7].
- facilitates HNB-GW discovery.
- provides configuration data to the HNB.
- performs location verification of HNB and assigns appropriate serving elements (HMS, Security Gateway and HNB-GW).

### 4.1.2 Security Gateway (SeGW)

The SeGW:

- terminates secure tunnelling for TR-069 [7] as well as Iuh.
- terminates secure tunnelling for Iurh and Gn/S5 for certain deployment options.
- authenticates HNBs.
- provides the HNB with access to the HMS and HNB-GW.

### 4.1.3 HNB Gateway (HNB-GW)

The HNB Gateway:

- terminates Iuh from HNB and appears as an RNC to the Core network.
- supports HNB registration and UE registration over Iuh.
- may terminate TNL for the Iurh interface, in case Iurh connectivity via the HNB-GW is deployed for at least one HNB or connectivity to an RNC via the HNB-GW.

- may support Fixed Broadband Access network interworking via S15 interface towards PCRF for CS sessions as specified in TS23.139 [36].

#### 4.1.4 HNB

The HNB:

- offers the Uu Interface to the UE.
- provides RAN connectivity using the Iuh and Iurh interfaces.
- acts as RNS (details are captured in Table 4.2-1).
- supports HNB registration and UE registration over Iuh.
- In case of LIPA support, it supports the following additional functions:
  - transfer of the Gn/S5 IP address of the HNB over Iuh.
  - support of basic GGSN/P-GW functions in the collocated L-GW function by support of the Gi/SGi interface corresponding to LIPA.
  - Support of use of the Correlation ID for correlation purposes between the collocated L-GW function and the HNB.
  - In case of Fixed Broadband Access network interworking support, it supports transferring of Tunnel Information over Iu/Iuh as specified in TS 23.139 [36].

#### 4.1.5 L-GW

The L-GW function within the HNB provides:

- in Idle mode, support for sending the first packet to the SGSN/SGW and, buffering of subsequent downlink packets.
- support of internal direct user plane path towards the corresponding HNB user plane functions.
- deactivation of the Gn/S5 interface connection.

The mobility of the LIPA PDN connection is not supported in this Release of the specification. The LIPA connection is always released with handover as described in TS 23.060 [10].

## 4.2 Functional split

The UTRAN functions in the HNB are supported by RANAP, whereas the HNB specific functions are supported by the Home NodeB Application Protocol (HNBAP) between the HNB and the HNB-GW. The HNB-GW provides a concentration function for the control plane and may provide a concentration function for the user plane.

This sub-clause defines the functional split between the core network and the UMTS radio access network. The functional split is shown in Table 4.2-1 and 4.2-2.

**Table 4.2-1. Functional split for UTRAN function in the HNB access.**

Function	HNB	HNB-GW	CN
<b>RAB management functions :</b>			
RAB establishment, modification and release	X	X <sup>NOTE 1</sup>	X
RAB characteristics mapping I <sub>u</sub> transmission bearers	X	X	
RAB characteristics mapping U <sub>u</sub> bearers	X		
RAB queuing, pre-emption and priority	X		X
<b>Radio Resource Management functions:</b>			
Radio Resource admission control	X		
Broadcast Information	X	X <sup>NOTE 2</sup>	X
<b>Iu link Management functions :</b>			
Iu signalling link management	X	X	X
ATM VC management		X	X
AAL2 establish and release		X	X
AAL5 management		X	X
GTP-U Tunnels management	X	X	X
TCP Management		X	X
Buffer Management	X	X	
<b>Iu U-plane (RNL) Management:</b>			
Iu U-plane frame protocol management			X
Iu U-plane frame protocol initialization	X		
<b>Mobility management functions :</b>			
Location information reporting	X		X
Handover and Relocation			
Inter RNC hard HO, Iur not used or not available	X	X	X
Serving RNS Relocation (intra/inter MSC)	X	X	X
Inter system hard HO (UMTS-GSM)	X	X	X
Inter system Change (UMTS-GSM)	X		X
Paging Triggering	X		X
Paging Optimization		X	
GERAN System Information Retrieval	X		X
<b>Security Functions :</b>			
Data confidentiality			
Radio interface ciphering	X		
Ciphering key management			X
User identity confidentiality	X		X
Data integrity			
Integrity checking	X		
Integrity key management			X
<b>Service and Network Access functions :</b>			
CN Signalling data	X		X
Data Volume Reporting	X		
UE Tracing	X		X
Location reporting	X		X
<b>Iu Co-ordination functions :</b>			
Paging co-ordination	X		X
NAS Node Selection Function		X	
MOCN Rerouting Function		X	X
<p>Note 1: This function could be needed for TNL address translation in the HNB-GW when there is no user plane direct transport connection between HNB and CN</p> <p>Note 2: HNB-GW is able to perform the filtering of SABP messages i.e. determines from the SAI list to which HNB the SABP message needs to be sent and then distributes the SABP messages to the appropriate HNBs. This is an optional function in HNB-GW.</p>			

Table 4.2-2. Functional split for HNB function in the HNB access.

Function	HNB	HNB-GW	CN
<b>HNB Registration</b> <sup>Note 1</sup>			
HNB Registration Function	X	X	
HNB-GW Discovery Function	X		
HNB de-registration Function	X	X	
<b>UE Registration for HNB</b> <sup>Note 1</sup>			
UE Registration Function for HNB	X	X	
UE de-registration Function for HNB	X	X	
<b>lurh user-plane Management functions</b>			
lurh User plane transport bearer handling	X	X	
Functions for multiplexing CS user plane on the Uplink	X	X	
<b>Traffic Offload Functions</b>			
LIPA	X		X
<b>Enhanced Interference Management</b>			
Mitigation of Interference from HNB to Macro	X		
<b>UE Access Control / Membership Verification</b>			
IDLE mode	X <sup>Note 2</sup>	X	X
Connected mode (inbound relocation to HNB cells)		X	X
CSG ID validation	X	X	
CSG Subscription Expiry	X	X	X
<b>lurh Connectivity Functions</b>			
lurh Establishment	X	X <sup>Note 3</sup>	
Exchange of lurh Connectivity data for neighbour HNBs	X	X	
<b>Fixed Broadband Access network Interworking</b>			
CS sessions	X	X	X
PS sessions	X		X
Note 1: Protocol support for this group of functions is provided by the HNB Application Protocol.			
Note 2: Access control or membership verification at the HNB are optional.			
Note 3: If the HNB-GW is involved in lurh Establishment for lurh connectivity option 2, it acts only as pure relay for this signalling.			

## 5 UTRAN functions for HNB access

### 5.1 UE Registration

#### 5.1.1 General

The UE Registration Function for HNB provides means for the HNB to convey UE identification data to the HNB-GW in order to perform access control or membership verification for the UE in the HNB-GW. The UE Registration also informs the HNB-GW of the specific HNB where the UE is located.

The following sections illustrate the case when the HNB registers a specific UE with the HNB-GW. The registration is triggered when the UE attempts to access the HNB via an initial NAS message (e.g., Location Updating Request) and there is no context in the HNB allocated for that UE.

## 5.1.2 UE Registration: case of non CSG UEs or non CSG HNBs

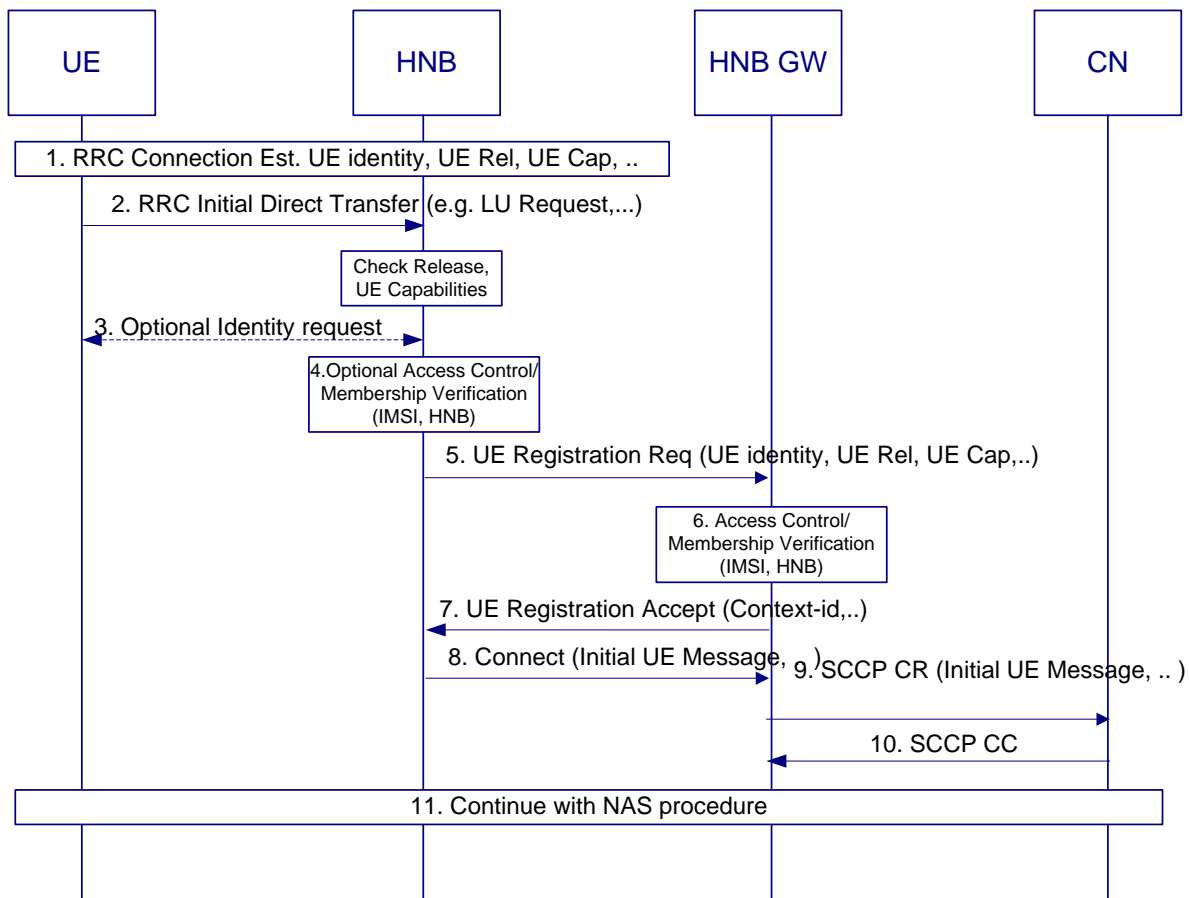

**Figure 5.1.2-1. UE Registration for non CSG UEs or non CSG HNBs.**

1. Upon camping on the HNB, the UE initiates an initial NAS procedure (e.g. LU Procedure) by establishing an RRC connection with the HNB. UE identity, UE capabilities and Establishment Cause, are reported to the HNB as part of the RRC Connection establishment procedure.
2. The UE then transmits a RRC Initial Direct Transfer message carrying the initial NAS message (e.g. Location Updating Request message) with some form of UE identity.
3. The HNB checks the UE capabilities provided in step 1, and if these indicate that CSG is not supported, or the HNB itself does not support CSG, and if the identity of the UE (provided during RRC Connection Establishment) is unknown at the HNB being accessed, i.e. no Context id exists for the UE, the HNB initiates UE registration towards the HNB-GW (step 5-7). Before starting the UE Registration procedure, the HNB triggers the Identity request procedure (step 3) asking the UE for its IMSI, unless that identity has been provided during the RRC Connection Establishment or optionally if it is an emergency call. If the HNB has a context id for the UE, the UE registration procedure is not performed nor is the Identification procedure.
4. The HNB may optionally perform access control or membership verification based on the provided IMSI and the provided Allowed IMSI list. If the UE requests emergency services it shall always be admitted to the cell.
5. The HNB attempts to register the UE on the HNB-GW by transmitting the UE REGISTER REQUEST. The message contains at a minimum:
  - **UE Identity:** a unique identity for the UE provided in step 1 or 3.
  - **UE Capabilities:** derived from that provided in step 1.
  - **Registration Cause:** the indication about a UE registration for an emergency call.

NOTE: The UE Identity provided in the HNBAP UE REGISTER REQUEST message is unauthenticated.

6. The HNB-GW checks the UE capabilities and the Registration Cause. If the UE capabilities indicate that CSG is not supported or if the HNB does not support CSG, the HNB-GW shall perform access control or membership verification for the particular UE attempting to utilize the specific HNB. If the UE requests emergency services it shall always be admitted to the cell.
7. If the HNB-GW accepts the UE registration attempt it shall allocate a context-id for the UE and respond with an HNBAP UE REGISTER ACCEPT message, including the context-id, to the HNB. For non-CSG UEs, the HNB-GW may also include the CSG Membership Status in the HNBAP UE REGISTER ACCEPT message. If the HNB-GW chooses not to accept the incoming UE registration request then the HNB-GW shall respond with an HNBAP UE REGISTER REJECT message.
8. The HNB then sends an RUA CONNECT message containing the RANAP Initial UE message. If a L-GW function is deployed within the HNB the RANAP Initial UE message includes the corresponding IP address for Gn/S5 signalling and user data transport on the Gi interface.
9. The reception of the RUA CONNECT message at the HNB-GW triggers the setup of an SCCP connection by the HNB-GW towards the CN. The HNB-GW then forwards the RANAP Initial UE Message to the CN.
10. The CN responds with an SCCP Connection Confirm message.
- 10a. The HNB-GW shall additionally utilize a CN assisted method if available (e.g. using IMSI provided in the COMMON ID message), to alleviate the security risks associated with spoofing of IMSI and can subsequently trigger a UE deregistration upon detection of such an event.
11. The UE continues with the NAS procedure (e.g. Location Updating procedure) towards the CN, via the HNB and the HNB-GW.

### 5.1.3 UE Registration: case of CSG UEs and CSG or Hybrid HNBs

This call flow assumes that the Core Network is able to perform access control on the basis of Closed Subscriber Groups.

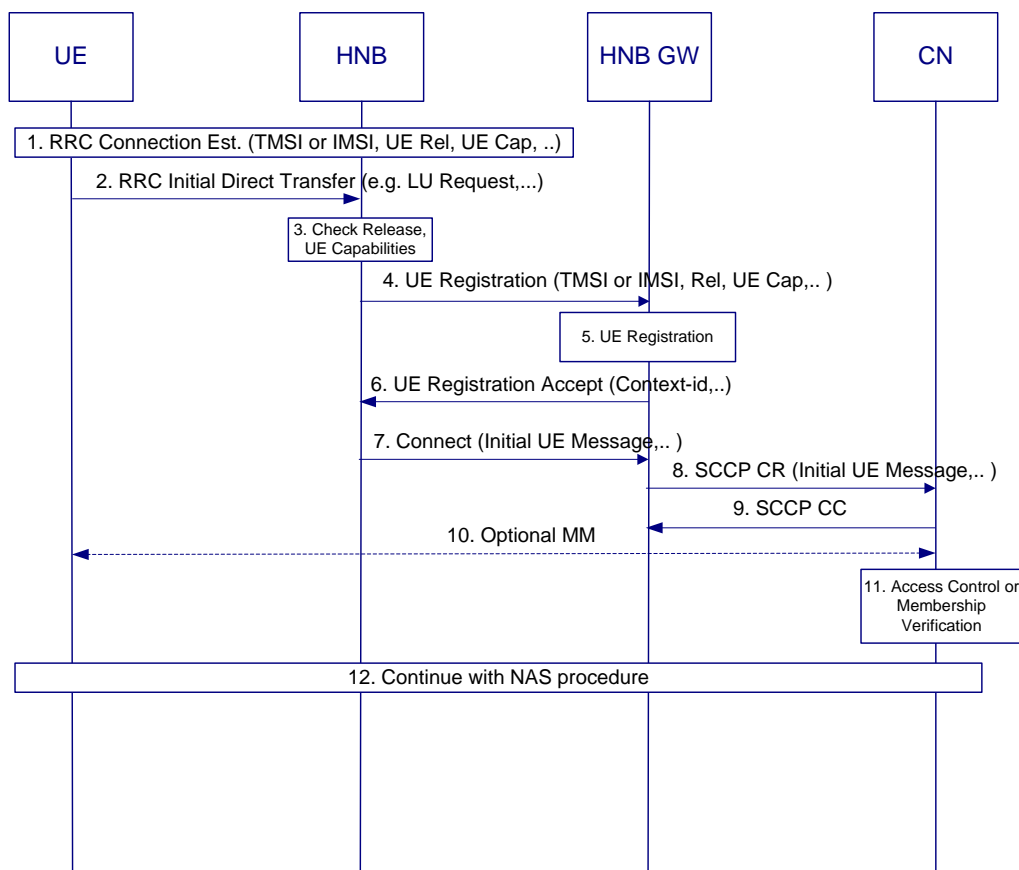

Figure 5.1.3-1. UE Registration for CSG UEs and CSG or Hybrid HNBs.



1. Upon camping on the HNB, the UE initiates an initial NAS procedure (e.g. LU Procedure) by establishing an RRC connection with the HNB. UE identity and UE capabilities are reported to the HNB as part of the RRC Connection establishment procedure.
2. The UE then transmits a RRC Initial Direct Transfer message carrying the initial NAS message (e.g. Location Updating Request message) with some form of identity (e.g. IMSI or TMSI...).
3. The HNB checks the UE capabilities provided in step 1, and if these indicate that CSG is supported and if the identity of the UE (provided during RRC Connection Establishment) is unknown at the HNB being accessed, i.e. no Context id exist for the UE, the HNB initiates UE registration towards the HNB-GW (steps 4-6). If the HNB has a context id for the UE, UE registration procedure is not performed. No Identification procedure is triggered, independent of the identity reported by the UE during the RRC Connection Establishment.
4. The HNB attempts to register the UE on the HNB-GW by transmitting the UE REGISTER REQUEST. The message contains:
  - **UE Identity**: a unique identifier for the UE and provided in step 1.
  - **UE capabilities**: derived from that provided in step 1.
  - **Registration Cause**: the indication about a UE registration for an emergency call.

NOTE: The UE Identity provided in the UE REGISTER message is unauthenticated.

5. The HNB-GW checks UE capabilities and if these indicate that CSG is supported and if the HNB supports CSG, the HNB-GW may accept the UE registration and allocate a context-id for the UE.
6. The HNB-GW responds with a UE REGISTER ACCEPT message back to the HNB including a context-id allocated to the UE
7. The HNB then sends a RUA CONNECT message containing the RANAP Initial UE message. The RANAP Initial UE message may contain the Cell Access Mode. If a L-GW function is deployed within the HNB, the RANAP Initial UE message includes the corresponding IP address for Gn/S5 interface signalling and user data transport on the Gi interface.
8. The HNB-GW shall verify, for CSG HNBs, that the validity of the indicated cell access mode and the CSG ID in the Initial UE message as specified in TS 33.320 [16]. The reception of the RUA CONNECT message at the HNB-GW triggers the setup of an SCCP connection by the HNB-GW towards the CN. The HNB-GW then forwards the Initial UE Message including the CSG id of the HNB.
9. The CN responds with an SCCP Connection Confirm message.
10. The CN may optionally perform Mobility Management procedures, e.g. Authentication procedure.
11. The CN performs access control (in case of CSG cells) or membership verification (in case of Hybrid cells) of the UE.
12. After being granted access the UE then continues with the NAS procedure (e.g. Location Updating procedure) towards the CN, via the HNB and the HNB-GW. During such procedures the CN may send to the HNB the UE membership status for the accessed cell in the COMMON ID message.

#### 5.1.4 HNB-GW triggered UE Registration

The following section describes the mechanism, which is used to manage UE registration and associated context IDs for the scenarios based on HNB-GW triggered setup of UE-associated Signalling Connection.

In this mechanism, the RUA Connect message is used for transporting the first RANAP message resulting in network triggered setup of UE-associated Signalling Connection (e.g. RANAP Relocation Request).

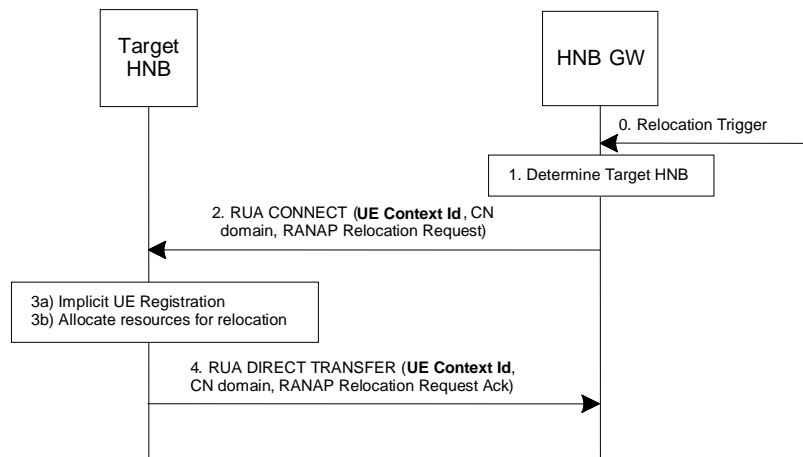

**Figure 5.1.4-1. HNB-GW Triggered UE Registration.**

The above call flow assumes that the HNB-GW receives a trigger for inbound relocation for a UE (e.g. RANAP Relocation Request message from the CN) as shown in step 0.

1. The HNB-GW receives a RANAP message and determines the target HNB.
2. The HNB-GW sends the RANAP message encapsulated in the RUA Connect message to the target HNB. The RUA Connect Message may contain the *CSG Membership Status IE*.
3. The HNB-GW and the target HNB perform an implicit registration (HNB-GW establishes a UE specific Context Identifier to be used between the HNB and the HNB-GW, i.e., either re-use the existing Context Identifier if already present for the UE or otherwise allocate a new one) for the incoming UE session. The HNB also allocates the appropriate resource for handling the request in the RANAP message.
4. The RANAP reply message from the HNB to the HNB-GW is encapsulated in the RUA *Direct Transfer* message.

In the case that the target HNB rejects the inbound relocation, the rejection message (e.g. RANAP Relocation Failure) is carried by a RUA Disconnect message, an implicit UE Deregistration takes place, and the resources allocated for handling the request are released.

## 5.1.5 UE Registration: case of Open Access HNBs

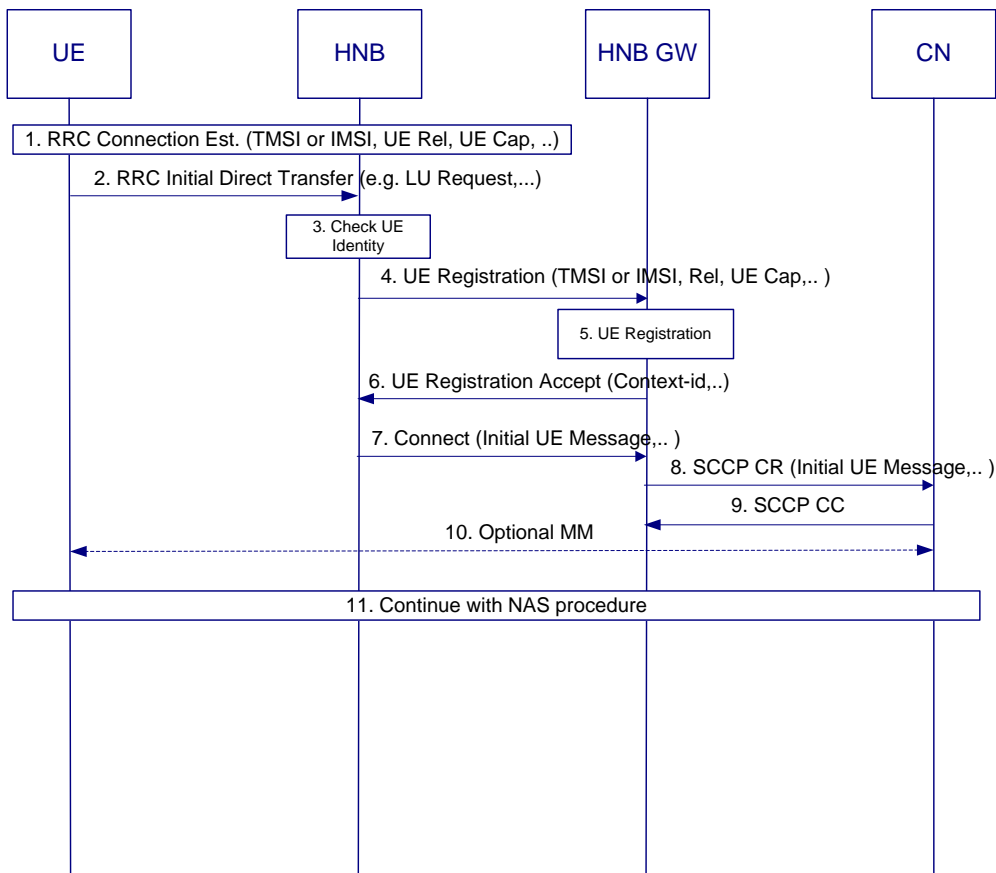

**Figure 5.1.5-1. UE Registration to open access HNBs.**

1. Upon camping on the HNB, the UE initiates an initial NAS procedure (e.g. LU Procedure) by establishing an RRC connection with the HNB. UE identity and UE capabilities are reported to the HNB as part of the RRC Connection establishment procedure.
2. The UE then transmits a RRC Initial Direct Transfer message carrying the initial NAS message (e.g. Location Updating Request message) with some form of identity (e.g. IMSI or TMSI).
3. If the identity of the UE (provided during RRC Connection Establishment) is unknown at the HNB being accessed, i.e. no Context id exist for the UE, the HNB initiates UE registration towards the HNB-GW (steps 4-6). If the HNB has a context id for the UE, UE registration procedure is not performed. No Identification procedure is triggered, independent of the identity reported by the UE during the RRC Connection Establishment.
4. The HNB attempts to register the UE on the HNB-GW by transmitting the UE REGISTER REQUEST. The message contains:
  - **UE Identity:** a unique identifier for the UE and provided in step 1.
  - **UE capabilities:** derived from that provided in step 1.
  - **Registration Cause:** the indication about a UE registration for an emergency call.

NOTE: The UE Identity provided in the UE REGISTER message is unauthenticated.

5. The HNB-GW may accept the UE registration and allocate a context-id for the UE.
6. The HNB-GW responds with a UE REGISTER ACCEPT message back to the HNB including a context-id allocated to the UE.
7. The HNB then sends a RUA CONNECT message containing the RANAP Initial UE message.

8. The reception of the RUA CONNECT message at the HNB-GW triggers the setup of an SCCP connection by the HNB-GW towards the CN. The HNB-GW then forwards the Initial UE Message to the Core Network.
9. The CN responds with an SCCP Connection Confirm message.
10. The CN may optionally perform Mobility Management procedures, e.g. Authentication procedure.
11. After being granted access the UE then continues with the NAS procedure (e.g. Location Updating procedure) towards the CN, via the HNB and the HNB-GW.

## 5.2 HNB Registration

### 5.2.1 General

The following section illustrates the case when the HNB registers with the HNB-GW. The HNB registration procedure serves the following purposes:

- It informs the HNB-GW that a HNB is now available at a particular IP address.

### 5.2.2 HNB Registration procedure

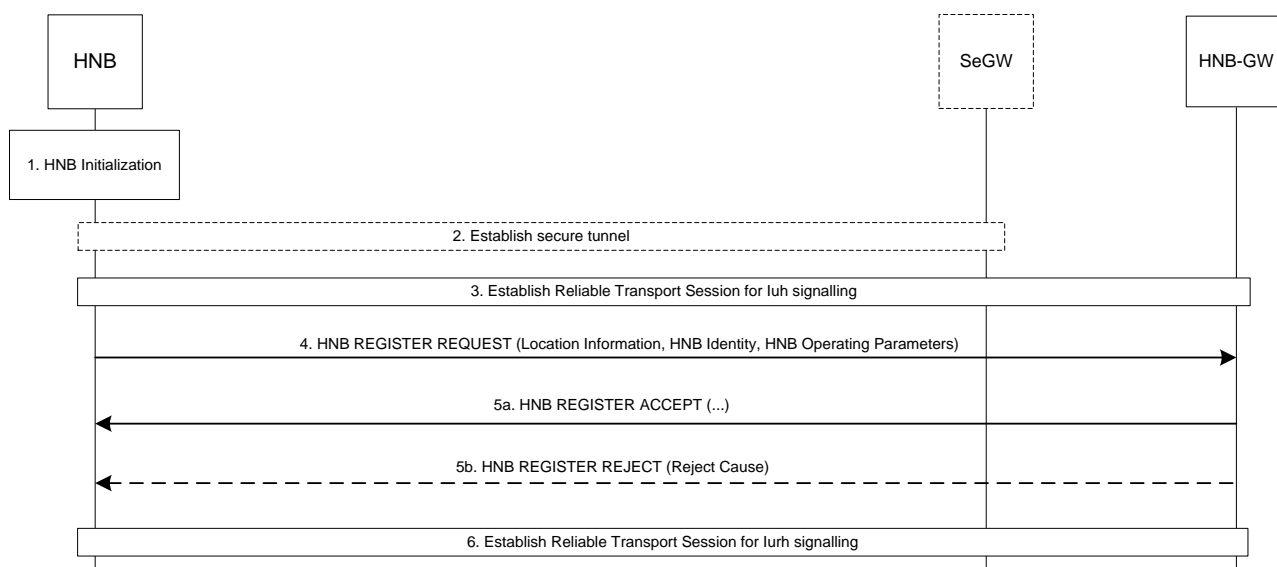

**Figure 5.2.2-1. HNB Registration procedure.**

1. HNB initialization is performed to obtain HNB configuration from the HNB Management System (HMS). Similarly, HNB-GW discovery is performed to obtain the initial serving HNB-GW information.

2. The HNB establishes a secure tunnel to the SeGW of the serving HNB-GW.

NOTE: This step may be omitted if the secure tunnel happens to be the same tunnel that is already established to contact the HMS.

3. The HNB sets up an SCTP transport session to the registered port on the serving HNB-GW for luh.
4. The HNB then attempts to register with the serving HNB-GW using an HNB REGISTER REQUEST message. The message contains:
  - a. **HNB Location Information:** The HNB provides location information via use of one or more of the following mechanisms:

- i. Detected macro-cell coverage information (e.g. GERAN or UTRAN cell information).
  - ii. Geographical co-ordinates (e.g. via use of GPS, etc).
  - iii. Internet connectivity information (e.g. IP address), provided, the resulting location information is at least as accurate as location determination based on macro-cell coverage information, whether or not there is macro cell-coverage available at the location of the HNB (e.g. as determined by point i above).
- b. **HNB Identity**: the HNB has a globally unique and permanent identity.
  - c. **HNB Operating Parameters**: Such as the selected LAC, RAC, SAC, PLMN Id, Cell Id, etc.
  - d. **HNB operating mode** (optional): HNB CSG-Id or access mode (open, closed or hybrid).
  - e. **HNB's own IP address** for direct Iurh connectivity (if Iurh connectivity is supported by the HNB).
- 5a. The HNB-GW may use the information from the HNB REGISTER REQUEST message to check whether the HNB registration can be accepted (e.g. to check whether a particular HNB is allowed to operate in a given location, etc). The HNB-GW shall verify the HNB identity, the validity of the indicated cell access mode and, for CSG cells, the CSG ID as specified in TS 33.320 [16]. If the HNB-GW accepts the registration attempt it shall respond with a HNB REGISTER ACCEPT message. If the HNB-GW has capability to de-multiplex, the HNB-GW may include a mux port in the HNB REGISTER ACCEPT message. The HNB shall include the RNC-ID provided by the HNB-GW within relevant RANAP messages in order to identify the HNB-GW during mobility procedures and within RRC messages, where the RNC-ID has to be contained within the most significant bits of the Cell Identification and be part of the U-RNTI. The HNB-GW may provide its IP address in order to allow the HNB to either establish Iurh-connectivity via the HNB-GW or to establish connectivity to an RNC via the HNB-GW.
- 5b. Alternatively, the HNB-GW may reject the registration request (e.g. due to network congestion, blacklisted HNB, unauthorized HNB location, etc). In this case, the HNB-GW shall respond with an HNB REGISTER REJECT indicating the reject cause.
6. If the HNB-GW had provided in the HNB REGISTER ACCEPT message the HNB-GW's own IP address for Iurh connectivity via/to the HNB-GW, the HNB shall, if supported, set up an SCTP transport session to the port registered for Iurh.

NOTE: The HNB shall start broadcasting only after successful registration with the HNB-GW.

## 5.3 HNB-GW Discovery Function

### 5.3.1 General

The HNB-GW Discovery Function provides the means to determine the address of the Serving HNB-GW for a particular HNB. The HNB uses the Serving HNB-GW address to register with the Serving HNB-GW.

## 5.4 HNB de-registration Function

### 5.4.1 General

The HNB de-registration Function provides the means to terminate the HNB operation. The HNB de-registration can be initiated by either the HNB or the HNB-GW.

## 5.5 Iuh Disconnect

### 5.5.1 General

The following section illustrates the scenario where an UE-associated signalling connection is released across the Iuh. In this scenario the HNB is responsible for initiating the release of the UE-associated signalling connection via the RUA

disconnect message. The HNB-GW is then responsible for co-ordinating the release of the UE-associated Iuh signalling connection with the corresponding Iu connection, which is triggered by the CN.

## 5.5.2 Iuh Disconnect procedure

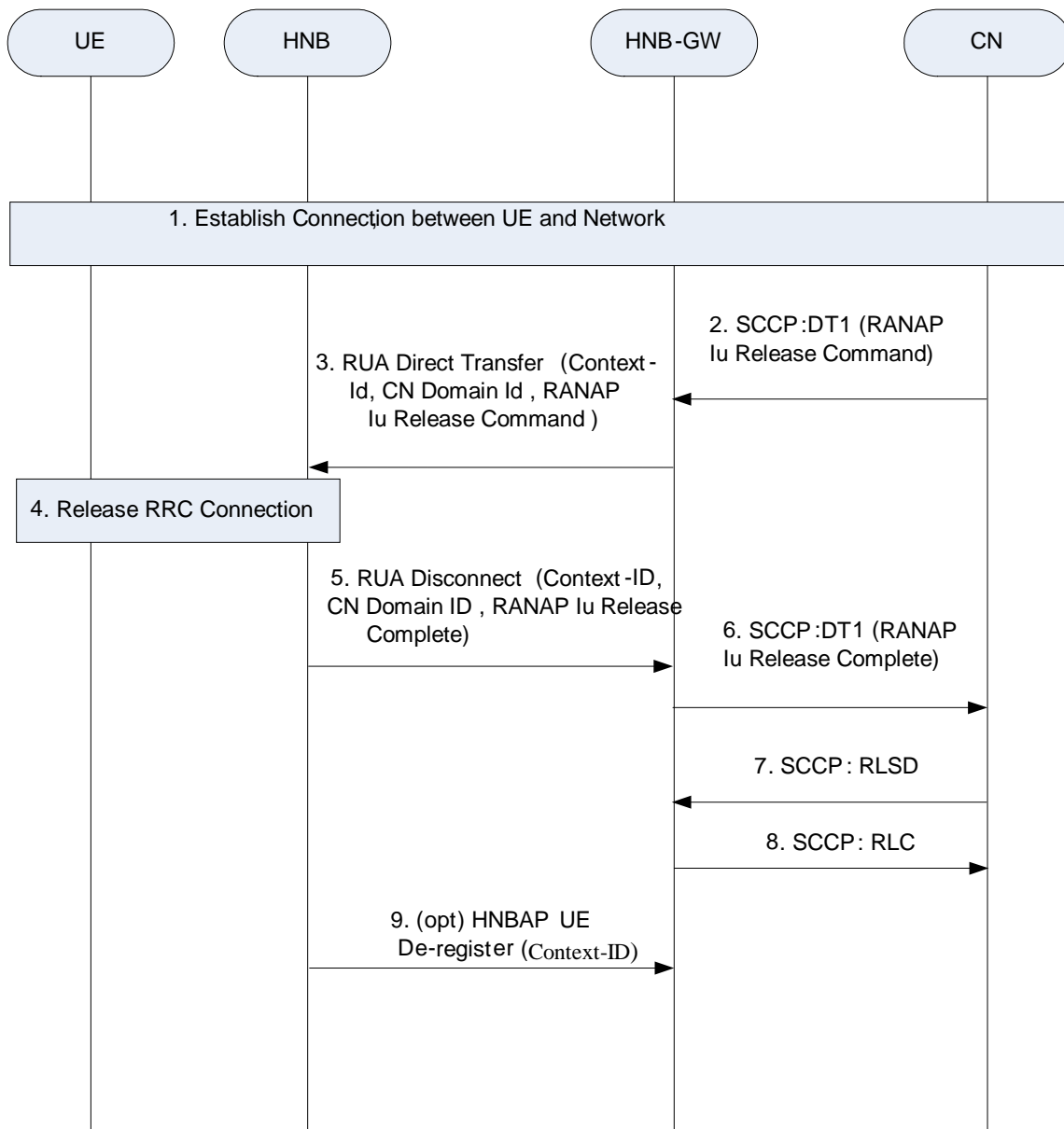

**Figure 5.5.2-1: Iuh Disconnect procedure.**

1. Establish connection between UE and network. The related procedure is described in subclause 5.1.
2. CN sends a RANAP Release Iu connection command message to the HNB-GW.
3. HNB-GW forwards this message to the relevant HNB.
4. HNB triggers the release of the RRC connection to the UE. In this case a single Iu connection had been established for the UE.
5. HNB sends a Disconnect message to the HNB-GW to indicate that this is the end of this particular UE-associated signalling connection and includes the RANAP Release Iu Connection Complete message.
6. HNB-GW forwards the RANAP message onto the CN.

7. CN triggers the release of the associated SCCP connection.
8. HNB-GW confirms that the SCCP connection is released.
9. Optionally the HNB can de-register the UE context from the HNB-GW.

## 5.6 Paging Optimization Function

### 5.6.1 General

The paging optimization function provides the means to decrease the impact of a paging load over Iurh (for example, via the use of knowledge about the UE Registration or its CSG Id List in the PAGING message).

## 5.7 HNB to HNB Mobility

### 5.7.1 General

The following sub-sections describe the mechanism for handling the intra HNB-GW mobility signalling via Iurh.

### 5.7.2 Connected mode mobility from one HNB to another HNB (Intra PLMN, Intra HNB-GW, Intra CSG)

#### 5.7.2.1 C-Plane Handling

RNSAP Relocation utilises existing protocol functions specified for Enhanced Relocation between non-CSG cells within TS 25.413 [9] and TS 25.423 [18].

Additional information from the Source HNB to the Target HNB is provided within the RANAP Enhanced Relocation Information and the RANAP Relocation Information procedures as specified in subclause 5.10.

Figure 5.7.2.1-1 below depicts the case where the UE is involved in the RNSAP Relocation and the HNBs are directly Iurh-connected. In case of UE not being involved, an Iurh signalling connection (i.e. RNA signalling resources) already exists between the involved HNBs which can be utilised for RNSAP signalling. In case of Iurh-connectivity via the HNB-GW, RNA signalling terminates at the HNB-GW, whereas RNSAP signalling is still performed peer-to-peer.

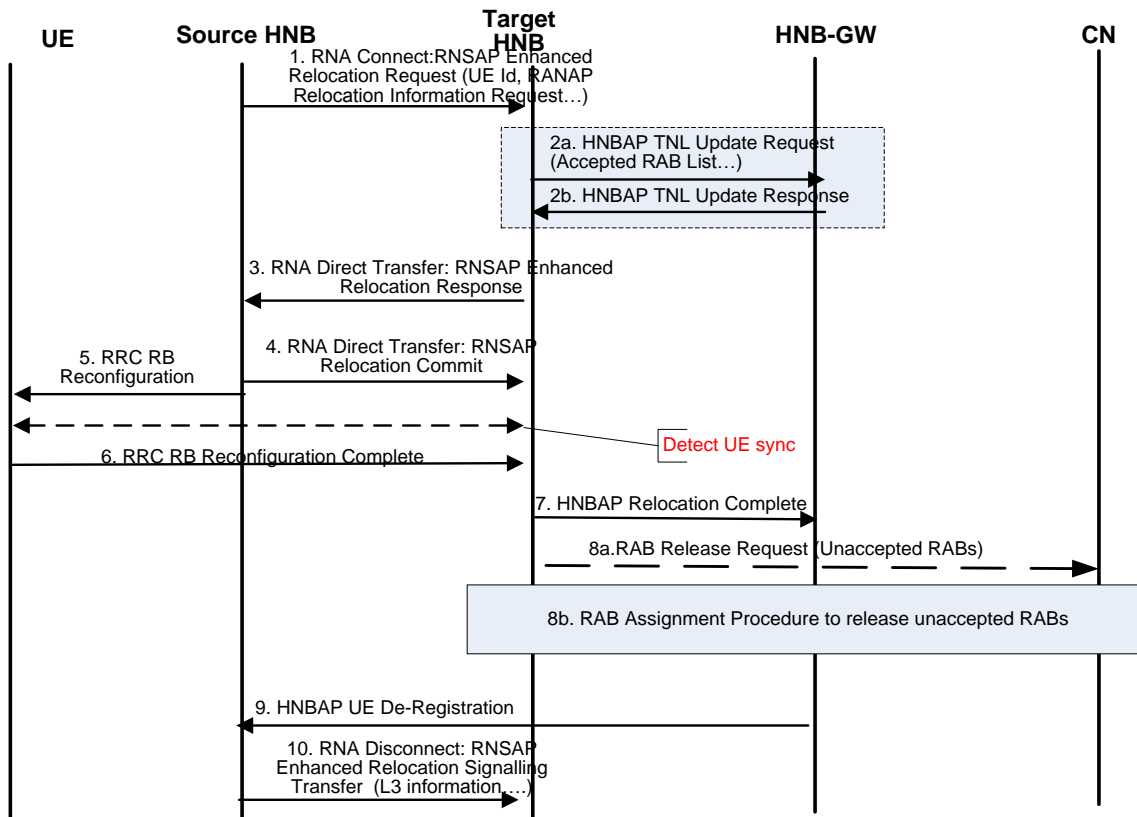

**Figure 5.7.2.1-1. HNB to HNB Handover via lurch interface – UE involved.**

1. The Source HNB evaluates the UE's access rights against the available neighbour information. If the UE has access rights for the Target HNB the Source HNB may decide to send an RNA:CONNECT message (or an RNA:DIRECT TRANSFER message if already in SHO) containing an RNSAP:ENHANCED RELOCATION REQUEST message to the Target HNB to prepare the Target HNB for relocation.
2. The Target HNB updates the transport network layer information for any RABs that are to be relocated to it by sending an HNBAP:TNL UPDATE REQUEST message to the HNB-GW, the HNB-GW responds with an HNBAP:TNL UPDATE RESPONSE.
3. The Target HNB sends an RNA:DIRECT TRANSFER message containing an RNSAP:ENHANCED RELOCATION RESPONSE message back to the Source HNB to indicate that it has successfully prepared the relocation.
4. The Source HNB sends an RNA:DIRECT TRANSFER message containing an RNSAP:RELOCATION COMMIT message, to commit the relocation preparation on the Target HNB. This message includes information to aid the relocation procedure, these are described in subclause 5.10.
5. The Source HNB reconfigures the UE to commence the relocation procedure.
6. At some point later Layer 1 synchronisation is achieved between the UE and the Target HNB. The UE then completes the RRC Reconfiguration procedure by sending an RRC:RADIO BEARER RECONFIGURATION COMPLETE message to the Target HNB.
7. The Target HNB indicates to the HNB-GW that the UE has successfully relocated via the HNBAP:UE RELOCATION COMPLETE message. The HNB-GW also switches the U-plane to the Target HNB.
8. The Target HNB initiates the RAB Release Request Procedure to the CN to release unaccepted RABs, if any, with an appropriate cause value.
9. The HNB-GW sends the HNBAP:UE-DEREGISTER to the Source HNB indicating Successful RNSAP Relocation with an appropriate cause value.



10. The Source HNB sends an RNA:DISCONNECT message containing an RNSAP:ENHANCED RELOCATION SIGNALLING TRANSFER message to the Target HNB to transfer any L3 information that the Source HNB may have received during the relocation procedure and locally releases any resources it has for the UE.

NOTE: If the involved HNBs are Iurh connected via the HNB-GW, the RNA messages are routed via the HNB-GW.

### 5.7.2.2 User Plane Handling

In order to keep the CN unaware of any Intra-GW mobility for RABs operating in support mode (see TS 25.415 [17]), which would normally need an Iu-UP initialization procedure during relocation, the respective user plane configuration (RFCIs, etc.) has to be transferred to the Target HNB without actually carrying out the Iu-UP Initialisation procedure towards its peer node. Special handling of related control and user data frame sequence numbers has to be applied.

In order to avoid problems with Iu-UP version interworking, the Target HNB shall support at least the same versions of Iu UP and rate parameters used by the Source HNB.

In order to allow seamless Iu-UP operation from a CN perspective,

- the Source HNB:
  - shall provide the Target HNB within RANAP ENHANCED RELOCATION INFORMATION REQUEST message with
    - CS IuUP control information needed to allocate IuUP instances for those RABs operated in support mode.
    - the latest CS Iu-UP user-data frame-numbers for UL and DL for all CS RABs operated in support mode for which user data frame numbering is based on time together with the time-difference between UL and DL packets as received/sent on the source side.
  - shall provide the Target HNB within RANAP RELOCATION INFORMATION message (encapsulated within the RNSAP message RELOCATION COMMIT) with
    - CS IuUP control information needed to allocate IuUP instances for those RABs operated in support mode, if the IuUP configuration of the RABs has changed.
    - the latest CS Iu-UP control-data frame-numbers for UL and DL for all CS RABs operated in support mode.
    - the latest CS Iu-UP user-data frame-numbers for UL and DL for all CS RABs operated in support mode for which user data frame numbering is based on time together with the time-difference between UL and DL packets as received/sent on the source side.
    - the last sent DL and last received and forwarded UL user-data frame number for those CS RABs for which user-data frame-numbering is based on sent Iu UP PDU.
    - the latest PS Iu-UP user-data frame-numbers for UL and DL for all applicable PS RABs.
    - may start to forward user plane packets towards the Target-HNB for those RABs for which it has decided to perform data forwarding, when triggering the execution of the RNSAP Relocation (exact sequence of actions is implementation specific).
    - not initiate any Iu-UP procedure and ignore incoming Iu-UP control frames, after having sent the RNSAP message RELOCATION COMMIT.
- the Target-HNB shall
  - after having received the RANAP ENHANCED RELOCATION INFORMATION REQUEST message
    - use the information provided by the Source HNB to establish Iu-UP instances for receiving user Iu-UP frames from the Source HNB and may use the information of the last CS Iu-UP UL/DL user-data frame number as received from the source together with received DL user-data frames to re-install the timing and frame-numbering for UL/DL user-data frames once the first DL user data packet is received from the Source HNB.

- use the information provided by the Source HNB to establish Iu-UP instances.
  - for each CS RAB operated in support mode, use the information of the last CS Iu-UP UL/DL user-data frame number as received from the source together with received DL user-data frames to re-install the timing and frame-numbering for UL/DL user-data frames once the first DL user data packet is received
  - not initiate any Iu-UP procedure and ignore incoming Iu-UP control frames.
- after having received the HNBAP: TNL UPDATE RESPONSE message from the HNB-GW
  - use the information provided by the Source HNB to establish Iu-UP instances for receiving user Iu-UP frames from the HNB-GW and use the information of the last CS Iu-UP UL/DL user-data frame number as received from the source together with received DL user-data frames to re-install the timing and frame-numbering for UL/DL user-data frames once the first DL user data packet is received from the HNB-GW.
  - not initiate any Iu-UP procedure and ignore incoming Iu-UP control frames.
- after having received the RNSAP message RELOCATION COMMIT
  - use the information of the last CS Iu-UP UL control-data frame number as received from the Source HNB for the next to be sent UL control-data frame.
  - ignore any loss of DL control frames and start respective error handling after the first received DL control frame.
  - use the information of the last CS Iu-UP UL/DL user-data frame number as received from the source together with received DL user-data frames to re-adjust the timing and frame-numbering for UL/DL user-data frames, if necessary.
  - start Iu-UP procedures as necessary (e.g. downlink rate control (due to e.g. local congestion), Iu Time Alignment).
- the HNB-GW shall
  - after receipt of the HNBAP:RELOCATION COMPLETE message
    - switch the TNL part of the UP completely towards the Target HNB.

### 5.7.3 Soft Handover Initiation

Figure 5.7.3-1 below depicts Soft Handover Initiation in case HNBs are directly Iurh-connected. In case of Iurh-connectivity via the HNB-GW, RNA signalling terminates at the HNB-GW, whereas RNSAP signalling is still performed on a HNB-to-HNB basis.

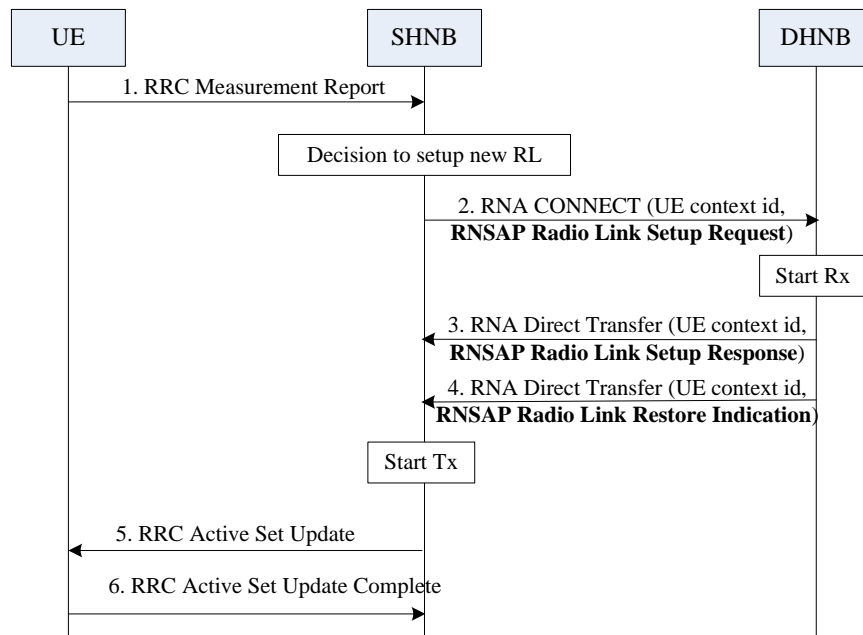

**Figure 5.7.3-1. Soft Handover Initiation HNB to HNB.**

1. The Serving HNB (SHNB) receives an RRC measurement report indicating that Soft handover is possible and the SHNB decides to setup a RL to the Drift HNB (DHNB).
2. The SHNB evaluates the UE's access rights against neighbour information available from the HNB Configuration Transfer function. If the UE has access rights for the DHNB, the SHNB may decide to setup a new RL and send an RNA:CONNECT message containing an RNSAP:RADIO LINK SETUP REQUEST message to the DHNB to set up a radio link at the DHNB.
3. The DHNB starts receiving from the UE and sends an RNSAP: RADIO LINK SETUP RESPONSE message.
4. When the radio link is established on the DHNB, the DHNB sends an RNSAP: RADIO LINK RESTORE INDICATION message.
5. The SHNB sends an RRC Active Set Update to the UE
6. The SHNB receives an RRC Active Set Update Complete from the UE.

## 5.7.4 Mobility Access Control

### 5.7.4.1 Limitations

The current version of the specification allows RNSAP relocation and SHO via Iurh only for the following scenarios:

- Intra-PLMN Intra-CSG Closed access cell to Closed access cell mobility
- Intra-PLMN Intra-CSG Hybrid access cell to Hybrid access cell mobility
- Open access cell to Open access cell mobility.

## 5.8 HNB Configuration Transfer

The HNB Configuration Transfer function provides the means to inform the HNB-GW to provide HNBs with address information of neighbour HNBs in order to enable the establishment of Iurh connection. The neighbour list is maintained in the HNB via interaction with the HMS. The HNB uses the IP addresses received from the HNB-GW to connect to neighbour HNBs over Iurh. The procedure for HNB Configuration Transfer is shown in Figure 5.8-1.

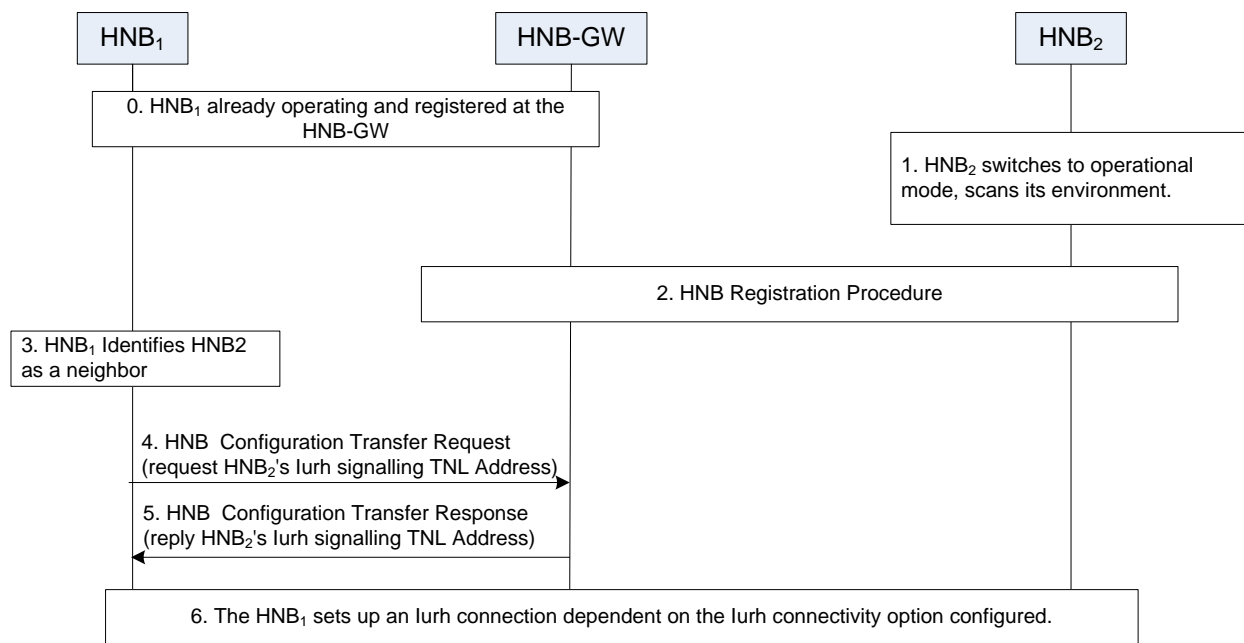

**Figure 5.8-1 HNB Configuration Transfer.**

0. HNB<sub>1</sub> has already switched to operational mode, has registered at the HNB-GW and is connected to HNBs within its reach.
1. HNB<sub>2</sub> switches to operational mode.
2. HNB<sub>2</sub> registers at the HNB-GW successfully and provides its IP address for direct Iurh connectivity.
3. HNB<sub>1</sub> identifies a change in its neighbour list, from e.g. detecting HNB<sub>2</sub> or via HMS.
4. HNB<sub>1</sub> requests the IP addresses of the Target HNB(s) by sending HNBAP HNB Configuration Transfer Request to the HNB-GW.
5. The HNB-GW responds with a HNB Configuration Transfer Response message to the source HNB providing for each neighbour HNB requested
  - either Iurh signalling TNL IP address information indicating the IP address to which the HNB shall setup an Iurh signalling connection and other information
  - or a reason why respective information cannot be provided.
6. The HNB<sub>1</sub> sets up an Iurh connection towards HNB<sub>2</sub>. If direct Iurh connectivity is applied, HNB<sub>1</sub> has to establish a reliable transport session before issuing the RNA:Iurh Setup procedure.

If the HNB-GW includes a list of Iurh signalling TNL addresses in the HNBAP HNB: CONFIGURATION TRANSFER RESPONSE message, the HNB establishes Iurh connection using the addresses provided in an ordered manner starting with the first entry of the list.

## 5.9 Iurh Setup

### 5.9.1 General

The purpose of this procedure is to setup an Iurh connection between two HNBs or between a HNB and a HNB-GW for HNB-RNC connectivity, and ensure that they have the necessary information for operation.

### 5.9.2 Iurh Setup for direct Iurh connectivity between HNBs

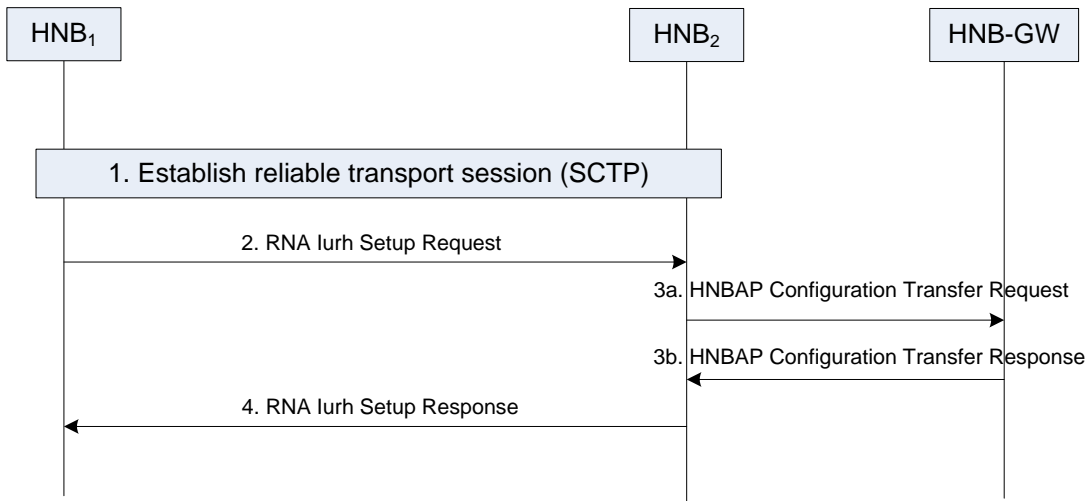
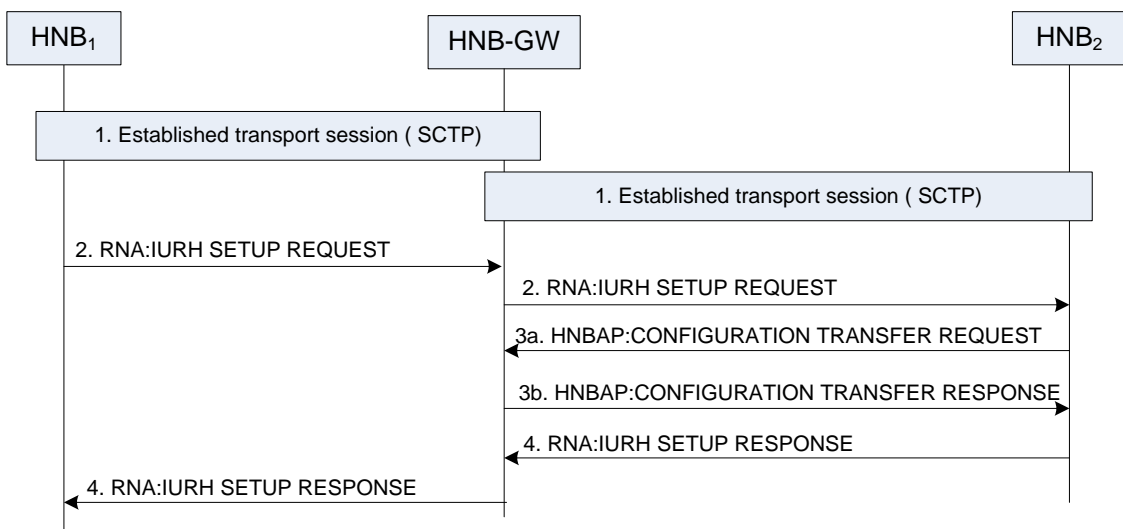

**Figure 5.9.2-1 Procedure for Iurh Setup - direct Iurh connectivity.**

The purpose of this procedure is to establish Iurh connectivity between two HNBs and ensure that the application level information is available to the two HNBs to interoperate correctly.

1. The HNB sets up an SCTP transport session, if required.
2. HNB<sub>1</sub> sends an RNA:IURH SETUP REQUEST to HNB<sub>2</sub>.
3. If HNB<sub>2</sub> does not have configuration information on HNB<sub>1</sub>, it triggers a request for the configuration information on HNB<sub>1</sub> from the HNB-GW.
4. HNB<sub>2</sub> responds to HNB<sub>1</sub>.

### 5.9.3 Iurh Setup for Iurh connectivity between HNBs via the HNB-GW

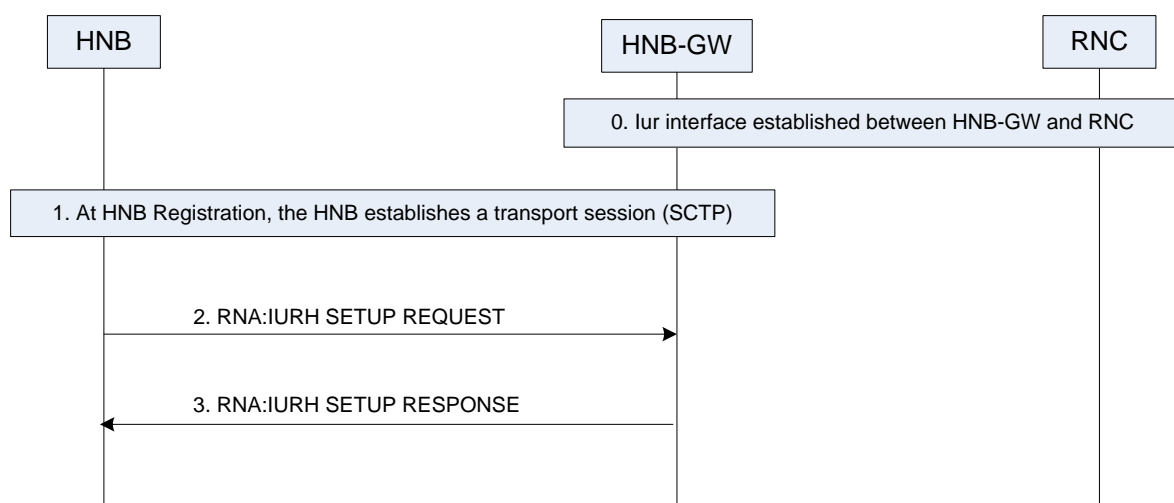

**Figure 5.9.3-1 Procedure for Iurh Setup-Iurh connectivity via the HNB-GW.**

The purpose of this procedure is to establish Iurh connectivity between two HNBs via the HNB-GW and ensure that the application level information is available to the two HNBs to interoperate correctly.

1. HNB<sub>1</sub> and HNB<sub>2</sub> have set up an SCTP transport session towards the HNB-GW at HNB Registration if they both support Iurh connectivity via the HNB-GW and where triggered by the HNB-GW to establish a transport session to it during HNB Registration.
2. HNB<sub>1</sub> provides within the RNA:IURH SETUP REQUEST message information which enables the HNB-GW to route the message to the HNB<sub>2</sub> and to enable the HNB<sub>2</sub> to reply via the HNB-GW.
3. If HNB<sub>2</sub> does not have configuration information on HNB<sub>1</sub>, it triggers a request for the configuration information on HNB<sub>1</sub> from the HNB-GW.
4. HNB<sub>2</sub> responds with a RNA:IURH SETUP RESPONSE to HNB<sub>2</sub> via the HNB-GW.

#### 5.9.4 Iurh Setup between the HNB and the HNB-GW for HNB-RNC connectivity



**Figure 5.9.4-1 Procedure for Iurh Setup - Iurh connectivity between the HNB and the HNB-GW for HNB-RNC connectivity.**

The purpose of this procedure is to establish Iurh connectivity between the HNB and the HNB-GW for connectivity between the HNB and the RNC and ensure that the peer RNC is available through the Iurh interface between the HNB and the HNB-GW.

0. An Iur interface instance is established between the RNC and the HNB-GW.
1. At HNB Registration the HNB has set up an SCTP transport session towards the HNB-GW.
2. HNB sends an RNA:IURH SETUP REQUEST to the HNB-GW to establish the connectivity towards the RNC via the HNB-GW. The RNC ID included in the RNA message identifies the peer RNC.
3. HNB-GW responds with an RNA:IURH SETUP RESPONSE to HNB if the Iur interface between the HNB-GW and the peer RNC is available.

## 5.10 Handling of Source information transfer to Target

In order to maintain the continuity of UE support during RNSAP Relocation, information must be transferred from the Source HNB to the Target HNB. RAB related information to ensure that continuity of User Plane and RAB establishment and other non-RAB related information is transferred in the RELOCATION COMMIT message.

## 5.10.1 RAB Related Parameters

### 5.10.1.1 User Plane

During RNSAP Relocation preparation phase, information is provided to the Target HNB in order to allow forwarding of user data. For each CS RAB operated in support mode (see TS 25.415 [17] for the definition of “support mode”) IuUP protocol data is provided to establish a respective IuUP instance at the Target HNB in a way that the CN is unaware of the RNSAP Relocation.

During the RNSAP Relocation execution phase, for each CS RAB operated in support mode, final counters of IuUP user data and control data frames are provided.

The behaviour of all involved nodes (Source HNB, Target HNB, HNB-GW) is fully specified in subclause 5.7.2.2.

### 5.10.1.2 Other parameters

During Relocation Commit the following information is transferred from the Source HNB to the Target HNB to maintain valid data volume reports.

RAB Data Volume Information, The unsuccessful data report transferred to the target to be accumulated at the target for the final Data Volume report on RAB release.

## 5.10.2 Non-RAB Related Parameters

During Relocation Commit the following information is transferred from the Source HNB to the Target HNB to continue non-RAB related functionality triggered at the Source HNB:

- Location Reporting parameters are transferred to the Target HNB to ensure continuity of Location Reporting.
- Trace Information parameters are transferred to the Target HNB to ensure continuity of Trace operations.
- The Service Area ID of the source cell is transferred to the target to enable the Target HNB to detect a change of service area and report this in the Location Reporting procedures.

## 5.8a CS user plane multiplexing

If the HNB-GW had signalled on the HNB REGISTER ACCEPT a mux port and if the HNB has capability to support CS user plane multiplexing, the HNB may send the multiplexed packets to the mux port at the HNB-GW.

The HNB, for the same UE, shall not send multiplexed packets over multiple ports. i.e., once the HNB chooses to multiplex CS user plane packets for a given UE on the uplink, it shall send those multiplexed packets only to the assigned mux port on the HNB-GW. For those UEs whose CS user plane packets are not being multiplexed, the HNB shall send packets only to the port number assigned via RAB assignment request.

When the HNB-GW receives multiplexed packet, it shall de-multiplex before sending them to the CN.

## 5.9a Inbound Mobility to HNB

### 5.9.1a General

The following sub-sections describe the mechanism for handling the inbound mobility to HNB via the Iu and Iuh interfaces. This mechanism is also applicable to the handover between HNBs under the same HNB-GW.

### 5.9.2a Connected Mode Inbound Mobility for CSG UEs to CSG HNBs or to Hybrid Cells

The following figure and accompanying steps describe the inbound mobility procedure for Rel-9 CSG UEs, when the Source RAN supplies to the Core Network a CSG id associated with the target HNB. The following is assumed:

- UE is Rel-9 CSG capable and SIB-reading capable.
- UE is able to provide in the RRC measurement report the cell identity and the CSG-Id (if requested) of the target HNB.
- The Source RAN is able to determine the Cell Access Mode of the target HNB.

NOTE: It is assumed that the network knows whether the target cell is a hybrid cell, e.g. by PSC range for hybrid cells.

- The Core network is Release-9 CSG capable and is able to perform access control or membership verification for relocated CSG UE.
- The HNB-GW is able to route the incoming relocation to the appropriate target HNB using the target cell identity provided in RANAP RELOCATION REQUEST (i.e. Target Cell Id is unique for a HNB in a given HNB-GW).

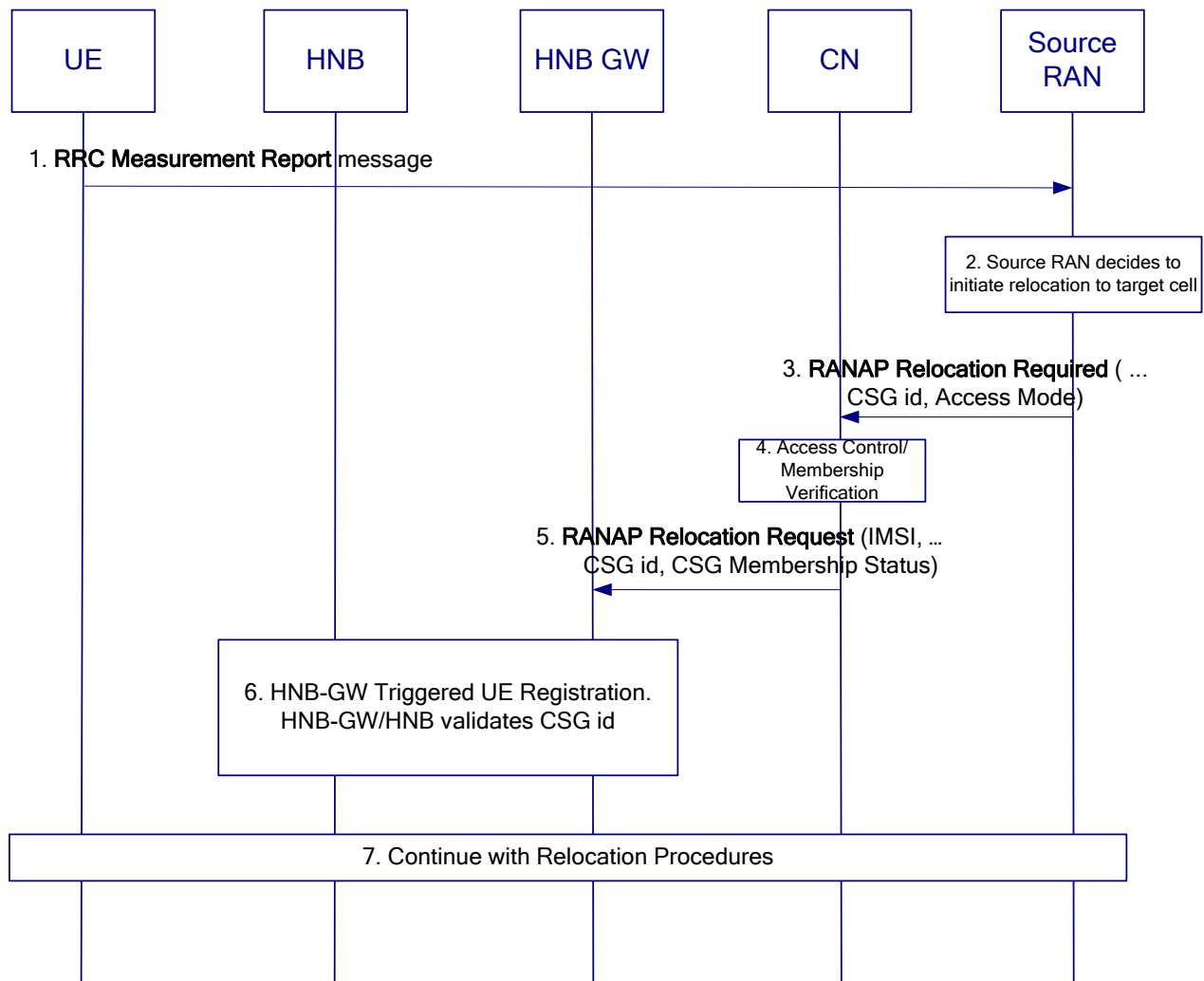

**Figure 5.9.2a-1: Connected Mode inbound mobility for CSG UEs to CSG HNB or Hybrid Cell.**

1. The UE is triggered to send an RRC Measurement Report by the rules set by the UTRAN. The Measurement Report includes the Cell Identity, CSG id (if requested) of the target HNB as in TS 25.331 [25].
2. The Source RAN node makes a decision to relocate the UE session.
3. The source RAN triggers relocation of the UE session by sending the RANAP RELOCATION REQUIRED message to the Core Network. The target RNC-Id, CSG id, Target Cell Id and – for relocation to a hybrid cell –



Cell Access Mode information along with relocation information are included by the source RAN in the RANAP RELOCATION REQUIRED message.

4. If the target cell is a CSG HNB, the Core Network performs access control on the basis of the CSG ID associated with the target cell, as reported to the Core Network (TS 25.413 [9]). Otherwise (if the target is a Hybrid Cell), the Core Network performs membership verification and fills the *CSG Membership Status* IE in step 5 to reflect the UE's membership to the target cell. If the Core Network determines that this relocation is for an emergency call then it will allow inbound mobility to CSG cells even if the access control fails and, in case of access control failure, the Core Network sets the *CSG Membership Status* IE to the value "non-member" in step 5.
5. The HNB-GW receives a RANAP RELOCATION REQUEST message from the Core Network, including the CSG id, Target Cell Id and – for relocation to a hybrid cell – CSG Membership Status. For cases where the access control failed for relocation of one or more RABs with a particular ARP value (see TS 23.060 [10]) to a hybrid or to a CSG cell the *CSG Membership Status* IE shall be included and set to "non-member".
6. The steps for HNB-GW Triggered UE Registration are executed between the HNB-GW and the HNB. The HNB-GW/HNB validates the CSG id received in the RANAP RELOCATION REQUEST message. If the CSG HNB determines that this relocation is for one or more RABs with a particular ARP value (see TS 23.060 [10]) and CSG ID validation fails and/or UE is non member then it will accept only those RABs with a particular ARP value (see TS 23.060 [10]) and fail the others.
7. The remainder of the relocation procedure continues normally as documented in TS 25.413 [9], TS 23.060 [10]

NOTE: Steps 2 to 7, as appropriate, are repeated for the second CN domain when present with the following exceptions. The relocation of the 2<sup>nd</sup> domain shall not trigger an additional registration. The 2<sup>nd</sup> RANAP Relocation Request shall be carried as RUA Direct Transfer. There is only one Context Id assigned to the UE regardless of the number of domains relocated from the source RAN.

### 5.9.3a Connected Mode Inbound Mobility for non-CSG UEs to CSG HNBs or to Hybrid Cells

The following figure and accompanying steps describe the inbound mobility procedure for non-CSG UEs, when the Source RAN is able to identify the target HNB. The following is assumed:

- UE is non-CSG capable not able to read SIBs for CSG inbound mobility purposes.
- The HNB-GW is able to perform access control or membership verification for the UE
- The HNB-GW is able to route the incoming relocation to the appropriate target HNB.

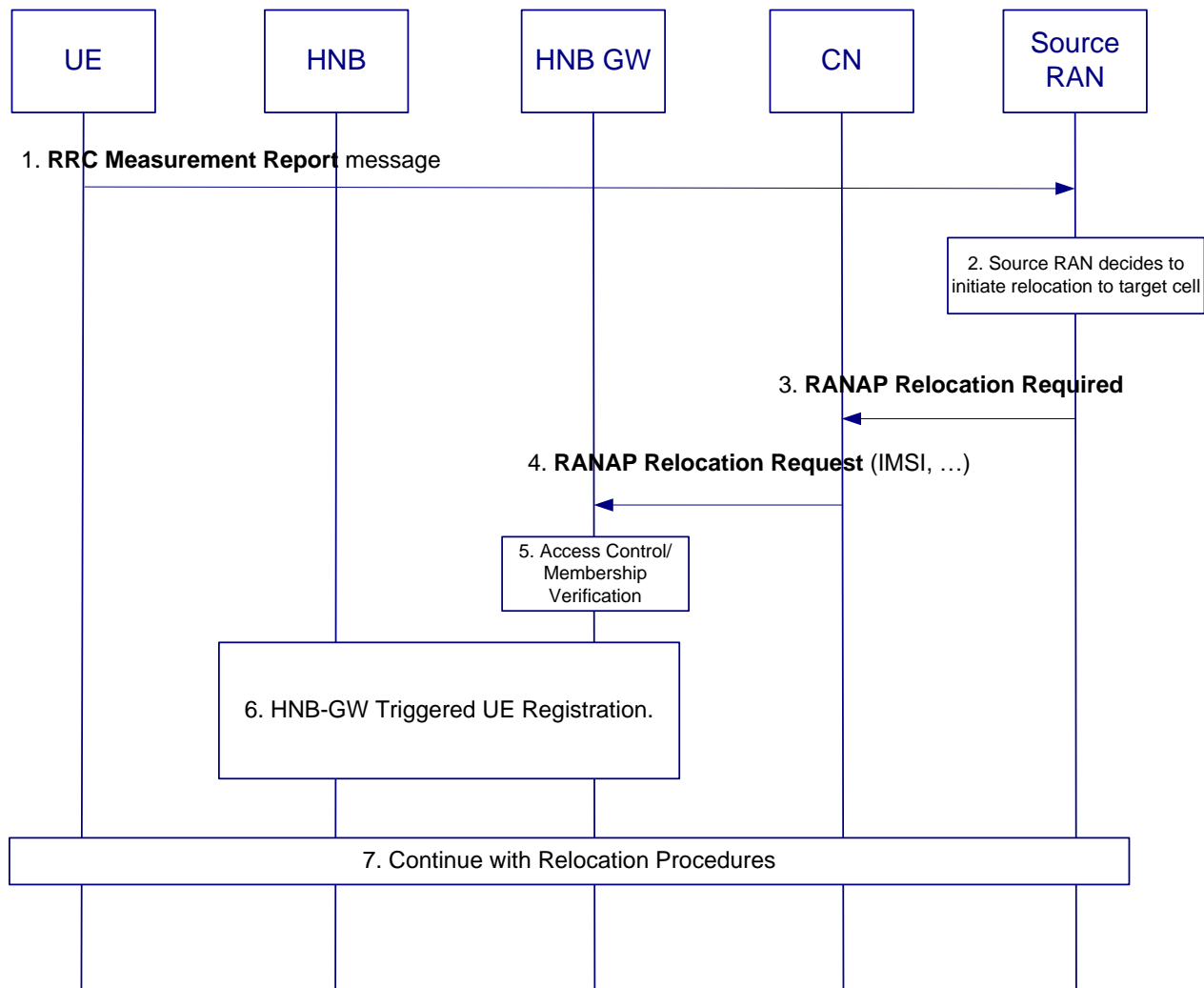

**Figure 5.9.3a-1: Connected Mode inbound mobility for non-CSG UEs to CSG HNB or Hybrid Cell.**

1. The UE is triggered to send an RRC Measurement Report by the rules set by the UTRAN as in TS 25.331[25].
2. The Source RAN node makes a decision to relocate the UE session.
3. The source RAN triggers relocation of the UE session by sending the RANAP RELOCATION REQUIRED message to the Core Network. The target RNC-Id and Target Cell Id are included by the source RAN in the RANAP RELOCATION REQUIRED message. The source RAN shall not include target CSG ID and the Cell Access Mode in the RELOCATION REQUIRED message.
4. The Core Network shall not perform any access control or membership verification for the UE and it shall not include target CSG ID and CSG Membership Status in the RELOCATION REQUEST message.
5. The HNB-GW receives a RANAP RELOCATION REQUEST message not including the target CSG ID and the CSG Membership Status. The HNB-GW shall perform access control (in case of CSG cells) or membership verification (in case of Hybrid cells) for the UE. If the relocation is towards a hybrid cell the HNB-GW may include the CSG Membership Status in the RUA Connect message. If the HNB-GW determines that this relocation is for one or more RABs with a particular ARP value (see TS 23.060 [10]) then it will allow inbound mobility to CSG cells even if the access control fails and, in case of access control failure, the HNB-GW sets the *CSG Membership Status* IE to the value “non-member” in the RUA Connect message.
6. The steps for HNB-GW Triggered UE Registration are executed between the HNB-GW and the HNB. If the CSG HNB determines that this relocation is for one or more RABs with a particular ARP value (see TS 23.060 [10]) and the UE is non member then it will accept only those RABs with a particular ARP value (see TS 23.060 [10]) and ensure that the others are not continued in the target cell.

7. The remainder of the relocation procedure continues normally as documented in TS 25.413 [9], TS 23.060 [10].

NOTE: Steps 2 to 7, as appropriate, are repeated for the second CN domain when present with the following exceptions. The relocation of the 2<sup>nd</sup> domain shall not trigger an additional registration. The 2<sup>nd</sup> RANAP Relocation Request shall be carried as RUA Direct Transfer. There is only one Context Id assigned to the UE regardless of the number of domains relocated from the source RAN.

### 5.9.4a Connected Mode Inbound Mobility to open access HNBs

The following figure and accompanying steps describe the inbound mobility procedure when the Source RAN is able to identify the target HNB. The following is assumed:

- The HNB-GW is able to route the incoming relocation to the appropriate target HNB.

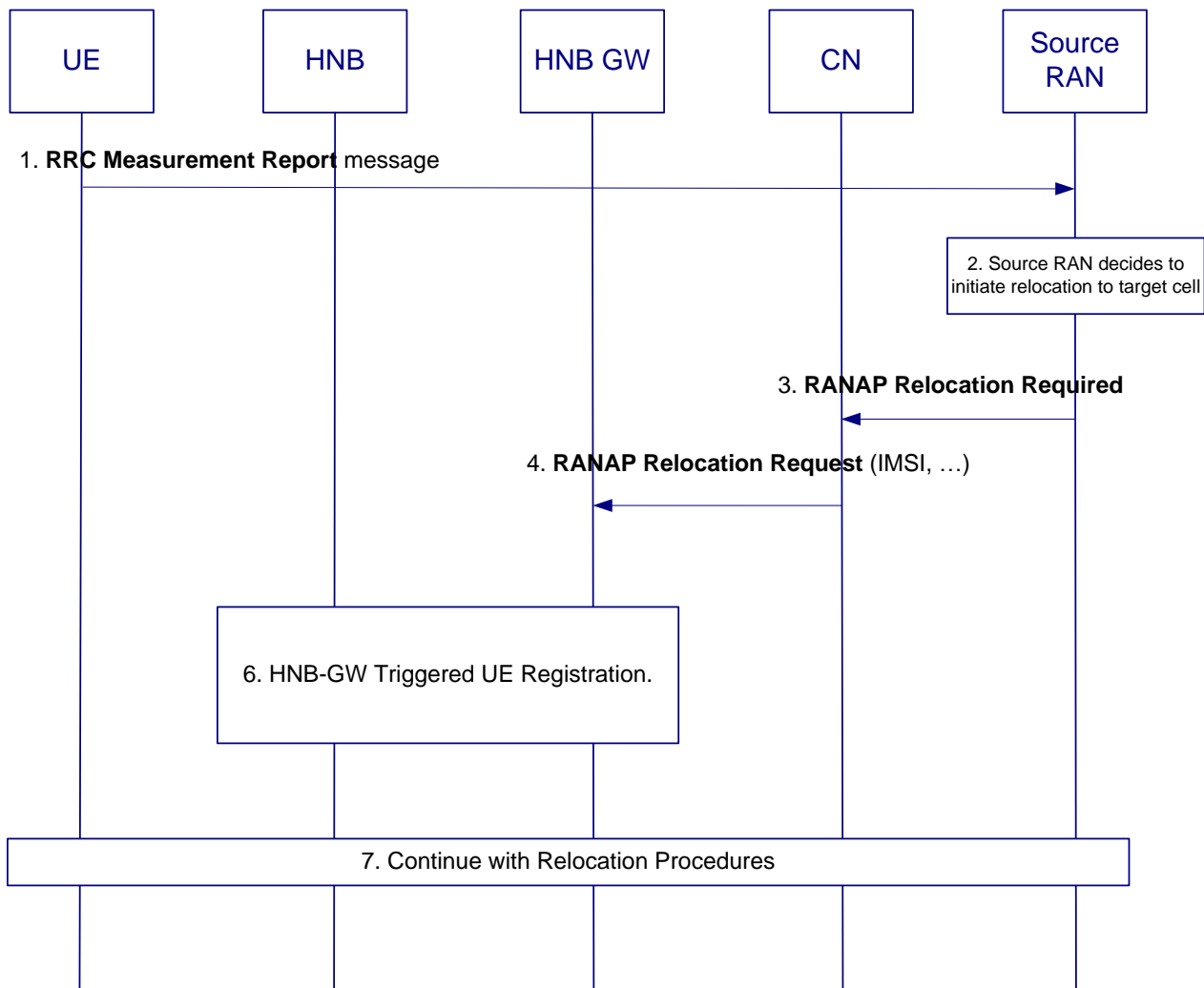

**Figure 5.9.4a-1: Connected Mode inbound mobility to open access HNBs.**

1. The UE is triggered to send an RRC Measurement Report by the rules set by the UTRAN as in TS 25.331[25].
2. The Source RAN node makes a decision to relocate the UE session.
3. The source RAN triggers relocation of the UE session by sending the RANAP RELOCATION REQUIRED message to the Core Network. The target RNC-Id and Target Cell Id are included by the source RAN in the RANAP RELOCATION REQUIRED message. The source RAN shall not include target CSG ID and the Cell Access Mode in the RELOCATION REQUIRED message.
4. The Core Network shall not perform any access control or membership verification for the UE and it shall not include target CSG ID and CSG Membership Status in the RELOCATION REQUEST message.

5. The HNB-GW receives a RANAP RELOCATION REQUEST message not including the target CSG ID and the CSG Membership Status.
6. The steps for HNB-GW Triggered UE Registration are executed between the HNB-GW and the HNB.
7. The remainder of the relocation procedure continues normally as documented in TS 25.413 [9], TS 23.060 [10]

NOTE: Steps 2 to 7, as appropriate, are repeated for the second CN domain when present with the following exceptions. The relocation of the 2<sup>nd</sup> domain shall not trigger an additional registration. The 2<sup>nd</sup> RANAP Relocation Request shall be carried as RUA Direct Transfer. There is only one Context Id assigned to the UE regardless of the number of domains relocated from the source RAN.

## 5.10a CSG Subscription Expiry

Case of CSG UEs:

If the CN has signalled CSG membership update to the HNB:

- If the UE is served by a CSG cell, and is no longer a member of the CSG cell, the HNB may initiate a handover to another cell. If the UE is not handed over, or handover is not initiated, the HNB should request the release of Iu connection (s) with an appropriate cause. The CN initiates Iu release after a configurable time, if the UE is not handed over or released by the CSG cell (TS 23.060 [10]).
- If the UE is served by a Hybrid cell, the HNB may use the new membership information to perform differentiated treatment for member and non-member UEs.

Case of non-CSG UEs:

If the HNB-GW has signalled CSG membership update to the HNB:

- If the UE is served by a CSG cell, and is no longer a member of the CSG cell, the HNB may initiate a handover to another cell. If the UE is not handed over, or handover is not initiated, the HNB should request the release of Iu connection (s) with an appropriate cause. The HNB-GW shall initiate UE De-Registration after a configurable time, if the UE is not handed over or released by the serving HNB.
- If the UE is served by a Hybrid cell, the HNB may use the new membership information to perform differentiated treatment for member and non-member UEs.

## 5.11 Connectivity between HNB and RNC via HNB-GW for RNSAP signalling

### 5.11.1 General

The following sub-sections describe the mechanism for handling Enhanced Relocation and Soft Handover between RNC and HNB via the HNB-GW.

### 5.11.2 Enhanced Relocation between HNB and RNC via HNB-GW

#### 5.11.2.1 Enhanced Relocation from Open Access and Hybrid HNBs to RNC

The mobility procedure described in Figure 5.11.2.2-1 requires the HNB-GW to route the incoming Enhanced Relocation signalling from the Source HNB to the appropriate Target RNC indicated by an RNC-ID provided within the RNA:CONNECT message.

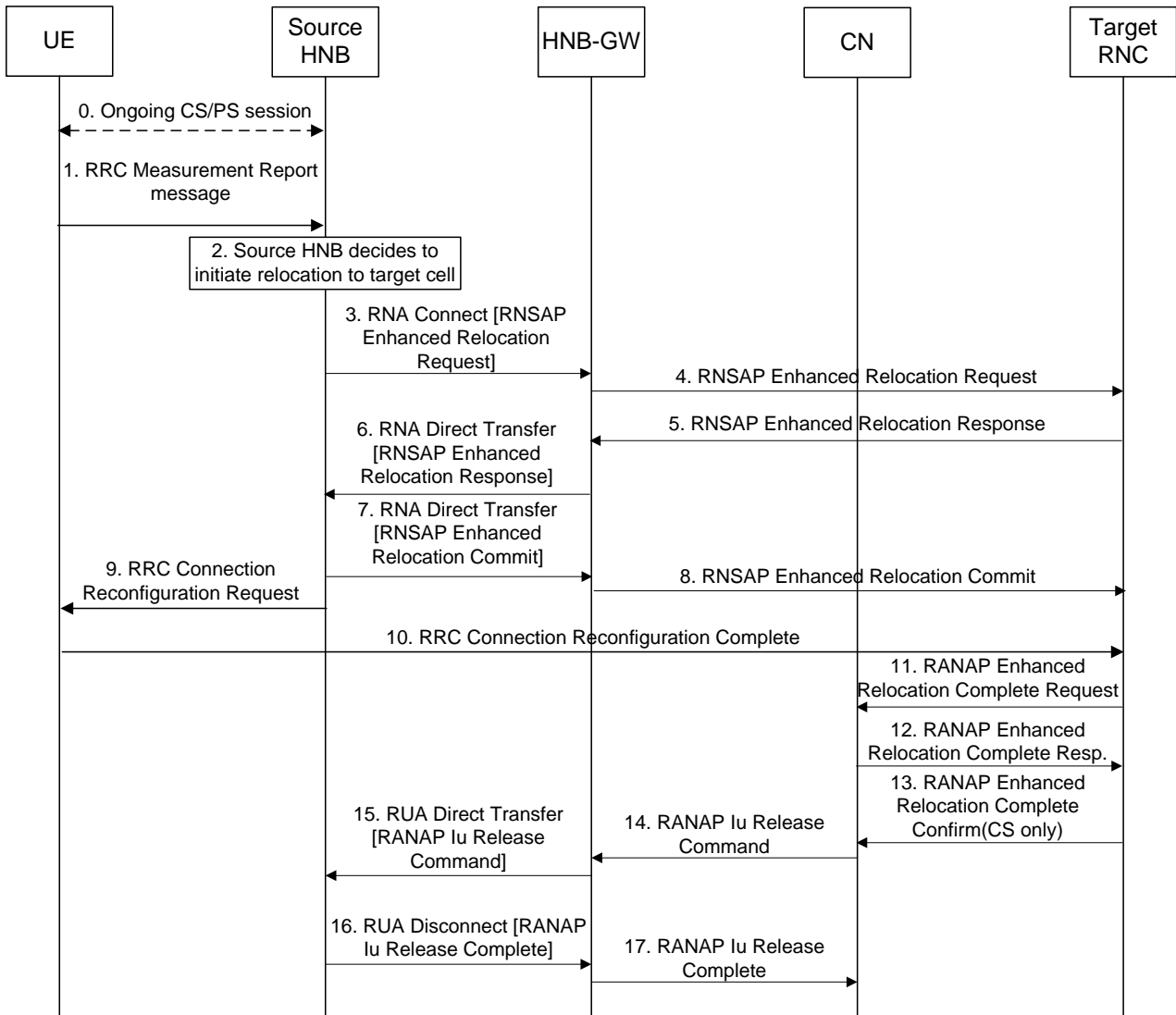

**Figure 5.11.2.1-1: Enhanced Relocation from Open Access and Hybrid HNBs to RNC.**

0-9. The RNSAP signalling for preparing and executing the relocation between the HNB and the RNC follows the standardised Enhanced SRNS Relocation procedure as defined between two RNCs (see TS 23.060 [10]).

10-13. After the UE has completed RRC signalling for the relocation, the RANAP: ENHANCED RELOCATION COMPLETE REQUEST message is sent from the Target RNC to the MSC/SGSN. The MSC/SGSN replies with a RANAP: ENHANCED RELCOATION COMPLETE RESPONSE message. In case of CS domain, the target RNC sends RANAP Enhanced Relocation Complete Confirm message to the MSC after completion of UP initialization.

14-17. Subsequently the CN initiates Iu Release procedure to release the source-side Iu(h) resources.

### 5.11.2.2 Enhanced Relocation from RNC to Open Access HNBs for CSG UEs

The mobility procedure described in Figure 5.11.2.2-1 requires the following:

- The Source RNC is able to determine the target HNB and its Cell Access Mode based on UE measurements.

**NOTE:** It is assumed that the source RNC has a priori knowledge whether the target cell is an open mode cell or not, e.g., via the PSC range configured for open cells in this part of the network

- The HNB-GW is able to route the incoming Enhanced Relocation signalling from the Source RNC to the appropriate target HNB using the target cell identity provided in RNSAP: ENHANCED RELOCATION REQUEST.

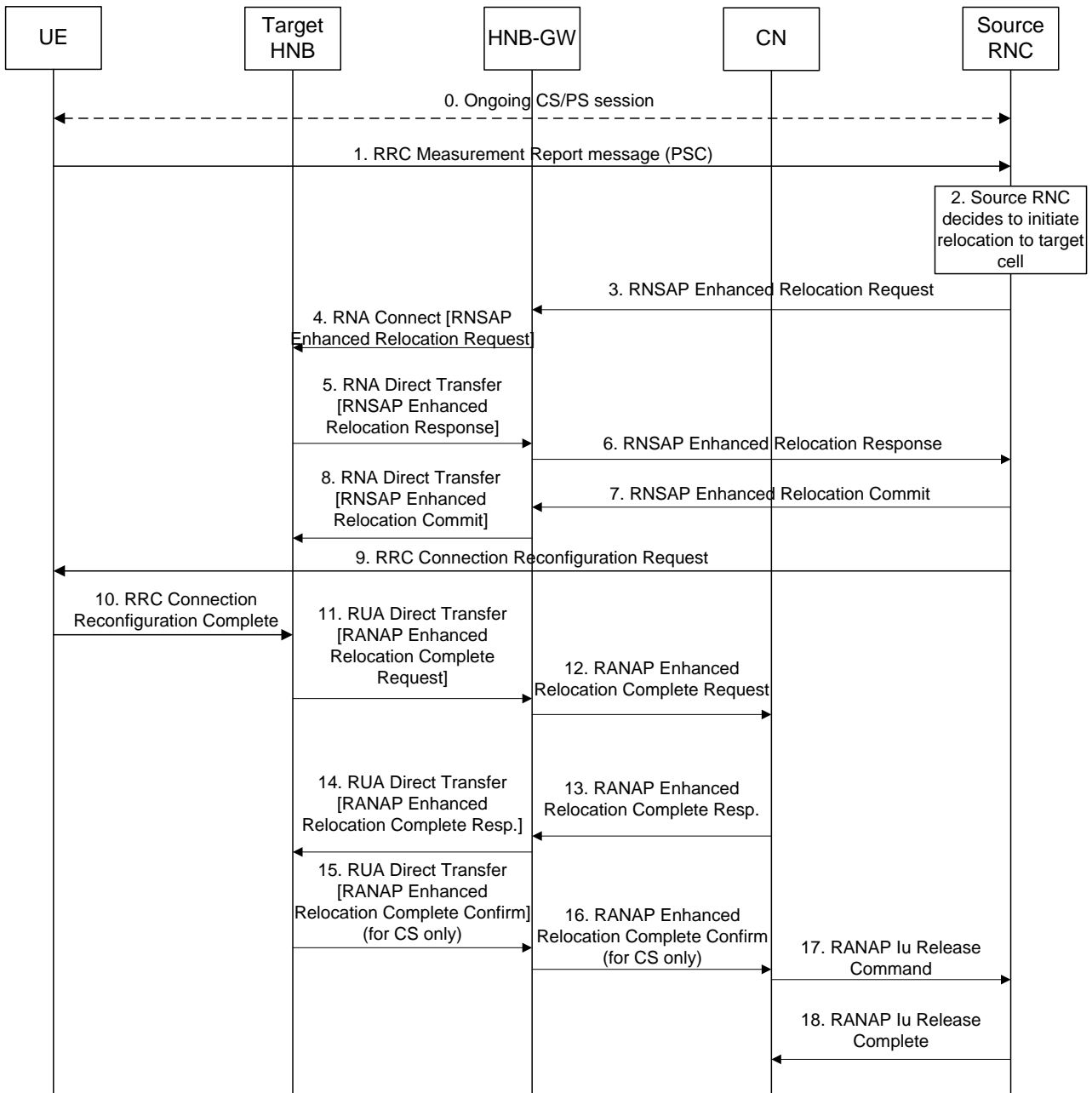

**Figure 5.11.2.2-1: Enhanced Relocation from RNC to Open Access HNB for CSG UEs.**

0-9. The RNSAP signalling for preparing and executing the relocation between the RNC and the HNB follows the standardised Enhanced SRNS Relocation procedure as defined between two RNCs (see TS 23.060 [10]).

10-12. After the UE has completed RRC signalling for the relocation, the RANAP: ENHANCED RELOCATION COMPLETE REQUEST message is sent from target HNB to HNB GW (via Iuh) and forwarded from HNB GW to MSC/SGSN (via Iu).

13-14. After the reception of RANAP: ENHANCED RELOCATION COMPLETE REQUEST the MSC/SGSN replies with RANAP: ENHANCED RELOCATION COMPLETE RESPONSE. The HNB-GW forwards this message to the target HNB (via Iuh).

15-16. In case of CS domain, the target HNB sends RANAP Enhanced Relocation Complete Confirm message to the MSC after completion of UP initialization.

17-18. The MSC/SGSN mandates the RNC to release the former Iu resources.

### 5.11.2.3 Enhanced Relocation from RNC to Hybrid HNB for CSG UEs

The mobility procedure described in Figure 5.11.2.3-1 requires the following:

- The UE is Rel-9 CSG capable and SIB-reading capable.
- The Source RNC is able to determine the Cell Access Mode of the target HNB.

**NOTE:** It is assumed that the source RNC is able to initiate and interpret respective UE measurements and may in addition have an a priori knowledge whether the target cell is a hybrid cell, e.g., via the PSC range configured for hybrid cells in this part of the network.

- The HNB-GW is able to route the incoming Enhanced Relocation signalling from the Source RNC to the appropriate target HNB using the target cell identity provided in RNSAP: ENHANCED RELOCATION REQUEST.

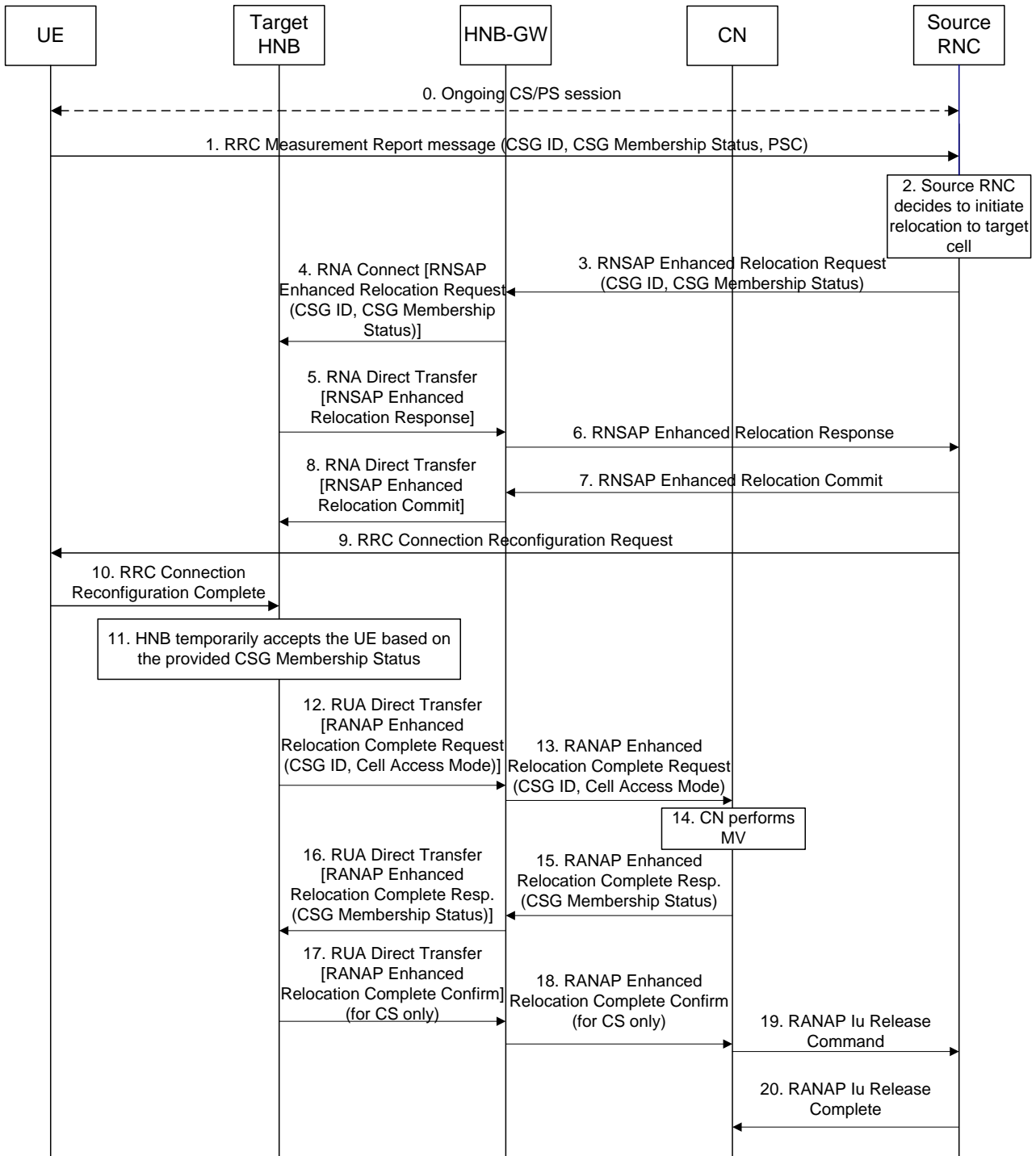

**Figure 5.11.2.3-1: Enhanced Relocation from RNC to Hybrid HNB for CSG UEs.**

0-9. RNSAP Signalling for preparing and executing the relocation between the RNC and the HNB follows the currently standardised Enhanced SRNS Relocation procedure as defined between two RNCs (See TS 23.060 [10]).

10-11. Upon successful relocation preparation and RRC signalling completion, the UE is temporarily admitted in the target hybrid cell according to the access status declared by the UE and provided by the Source RNC to the Target HNB within the *CSG Membership Status* IE included in the RNSAP: ENHANCED RELOCATION REQUEST message. The UE may be admitted as its reported CSG membership status until the outcomes of membership verification are received from CN.



12-13. The RANAP: ENHANCED RELOCATION COMPLETE REQUEST message is sent from target HNB to HNB GW (via Iuh) and forwarded from HNB GW to MSC/SGSN (via Iu). The RANAP: ENHANCED RELOCATION COMPLETE REQUEST includes *CSG ID IE* and *Cell Access Mode IE* of the target cell.

14-16. After reception of RANAP: ENHANCED RELOCATION COMPLETE REQUEST the MSC/SGSN performs membership verification of the relocated UE according to *CSG ID IE* and *Cell Access Mode IE* received. The MSC/SGSN replies to the HNB GW with RANAP: ENHANCED RELOCATION COMPLETE RESPONSE containing the *CSG Membership Status IE*. The RANAP: ENHANCED RELOCATION COMPLETE RESPONSE message is forwarded from HNB GW to target HNB (via Iuh). The target HNB may apply the appropriate level of prioritisation to the UE according to the *CSG Membership Status IE* received.

17-18. In case of CS domain, the target HNB sends RANAP Enhanced Relocation Complete Confirm message to the MSC after completion of UP initialization.

19-20. The MSC/SGSN requests the RNC to release the source-side Iu resources.

### 5.11.3 Soft Handover between HNB and RNC via HNB-GW

#### 5.11.3.1 Soft Handover from HNB to RNC

Mobility from HNB cells (hybrid or open access) to macro RNC using Soft Handover (SHO) follows the same principles as mobility between macro cells and uses an Iur interface established between HNB and macro RNC via the HNB-GW to support RNSAP signalling.

The HNB-GW acts as a single RNC towards the macro RNC (as it does towards the CN) and therefore acts as a concentrator for HNB-RNC connectivity via the HNB-GW.

For this case there is no involvement of the CN in the SHO operations, as there is no access control/membership verification needed for SHO to a macro RNC.

The HNB acts as a SRNC and requests resources from the macro RNC, however this may happen only in case of HNBs deployed in a secure and operator controlled way (coordinated deployment) and, in this case, it is managed by the CAC of the DRNC.

Figure 5.11.3.1-1 shows the sequence of messages involved.

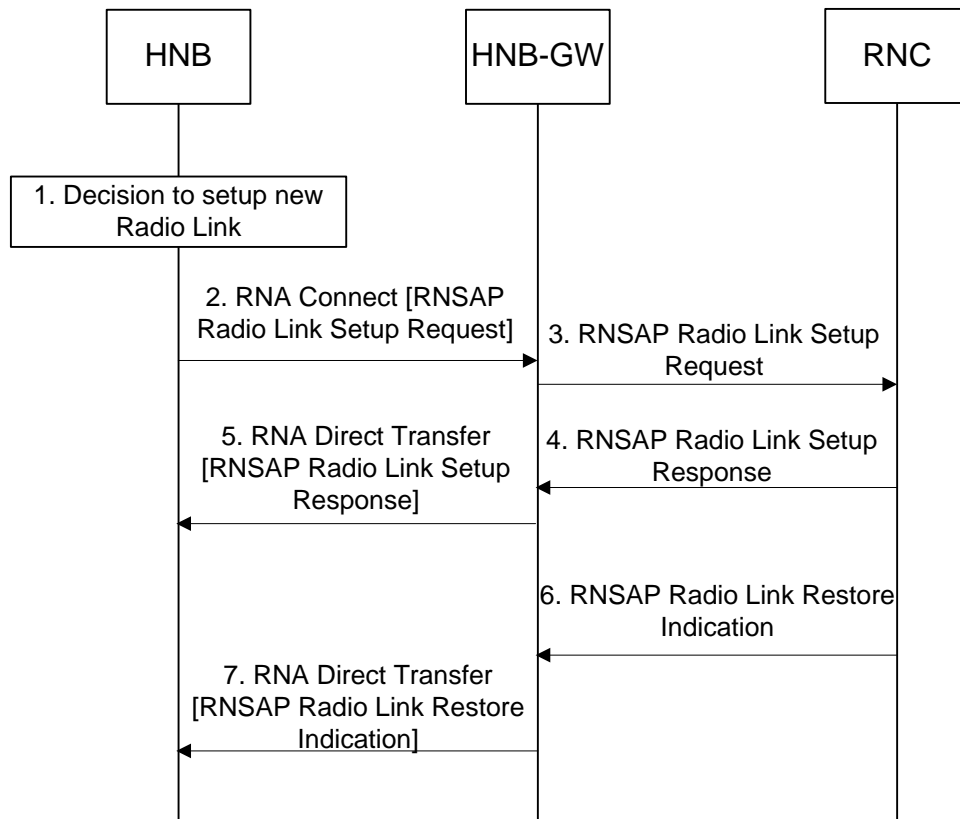

**Figure 5.11.3.1-1: Soft Handover HNB to RNC via HNB-GW.**

1. HNB determines that a RL can be established to a macro RNC cell.
- 2-7. Normal RL setup procedure between HNB and RNC via the HNB-GW.

### 5.11.3.2 Soft Handover from RNC to Open or Hybrid Access HNB

Mobility from macro cells to Open or Hybrid Access HNB cells using Soft Handover follows the same principles as mobility between macro cells and uses an Iur interface established between the HNB and the macro RNC via the HNB-GW to support RNSAP signalling.

The HNB-GW acts as a single RNC towards the macro RNC (as it does towards the CN) and therefore acts as a concentrator for HNB-RNC connectivity via the HNB-GW.

For this case of open or hybrid access HNB, there is no involvement of the CN in the SHO operations. For the case of SHO to hybrid access HNB, if supported, the Radio Link is established assuming the UE is non-member.

The macro RNC acting as SRNC requests resources from the HNB, it is managed by the CAC of the HNB.

Figure 5.11.3.2-1 shows the sequence of messages involved.

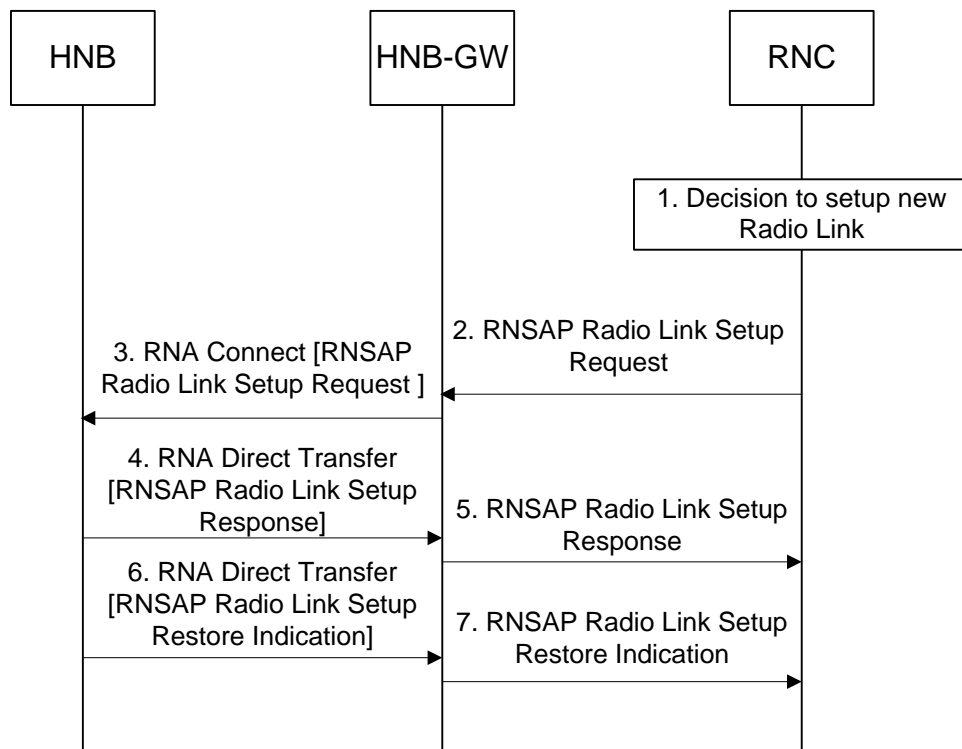

**Figure 5.11.3.2-1: Soft Handover from RNC to Open or Hybrid Access HNB via HNB-GW.**

1. RNC determines that a RL can be established to a HNB cell.
- 2-7. Normal RL setup procedure between RNC and HNB via the HNB-GW. For Hybrid cells, if supported, the Radio Link is established assuming the UE is a non-member.

## 5.12 Fixed Broadband Access network Interworking

Case of CS sessions:

The HNB signals the Tunnel Information to the HNB GW via the HNB Registration procedure. The Tunnel Information includes HNB IP address and the UDP port number if NAT/NAPT is detected. The HNB-GW establishes and manages the S15 session by the tunnel information and RAB information as specified in TS 23.139 [36].

Case of PS sessions:

The HNB signals the Tunnel Information to the SGSN via INITIAL UE MESSAGE message, RELOCATION COMPLETE message, and ENHANCED RELOCATION COMPLETE REQUEST message. The Tunnel Information includes HNB IP address and the UDP port number if NAT/NAPT is detected.

## 6 Requirements for O&M

### 6.1 O&M for HNB

#### 6.1.1 Provisioning Procedure for HNB

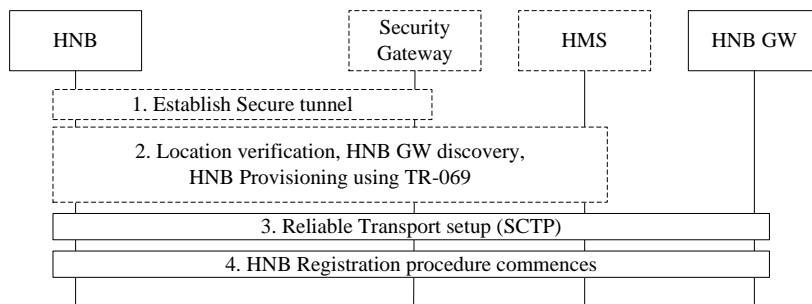

**Figure 6.1.1-1. Provisioning procedure for HNB.**

1. A secure tunnel is established from the HNB to the Security gateway.
2. Location verification shall be performed by the HMS based on information sent by the HNB (e.g. macro neighbour cell scans, global navigational satellite system type of information etc.). HMS determines the serving elements and provides the HNB-GW, HMS and Security Gateway to the HNB. The HMS also provisions configuration parameters to the HNB only after successful location verification in the HMS.

NOTE: Steps 3 & 4 are shown only for completeness. Security Gateway and HMS are shown to highlight the general architecture.

NOTE: In the event information required for verifying location are not available (for example, no macro neighbour cells, no GNSS, no DSL line ID etc. available), HNB-GW discovery may be based on specific operator and/or regulatory policies.

### 6.1.2 Location Verification

#### 6.1.2.1 General

During location verification, the HNB reports its location information to the HMS. The HMS in turn examines the provided information and verifies the HNB's location. There are 3 possible types of information for this purpose:

1. Macro-cell Information
2. GNSS location information
3. Broadband connection information, provided that the resulting location information is at least as accurate as location determination based on macro-cell coverage information, whether or not there is macro-cell coverage available at the location of the HNB (e.g. as determined by point 1. above).

NOTE: Not all of this information is mandatory. In fact, the type of reported information is based on factors such as the physical environment in which the HNB is installed and/or possible variations in the HNB's HW and SW implementation.

#### 6.1.2.2 Macro-cell Information

##### 6.1.2.2.1 General

The HNB is expected to have a radio environment measurement capability. This includes capturing the following type of information from the surrounding environment.

- a) UTRAN cell information
  - RF level information
  - Broadcast information
- b) GSM cell information
  - RF level information
  - Broadcast information

#### 6.1.2.2.2 UTRAN Cell Information

The information in the following table is reported by the HNB to the HMS for each UTRAN cell detected.

**Table 6.1.2.2-1. UTRAN Cell Information.**

Information		Description / Note	Presence	3GPP Reference
RF information	UARFCNDL	UARFCN (DL)	M	TS 25.104 [23] sec.5.4, TS 36.642 [24] sec. 6.3.11
	CPICHRSCP	RSCP of CPICH	M	
	PSC	Primary Scrambling Code	M	TS 32.642 [24] sec. 6.3.11
Broadcast information	PLMN Type	« GSM-MAP » or « ANSI-41 »	M	TS 25.331 [25] sec.10.3.1.12
	MCC	Mobile Country Code	M	TS 24.008 [26], TS 32.642 [24] sec. 6.3.10
	MNC	Mobile Network Code	M	TS 24.008 [26], TS 32.642 [24] sec. 6.3.10
	LAC	Location Area Code	M	TS 24.008 [26] sec.10.5.1.3, TS 32.642 [24] sec. 6.3.10
	RAC	Routing Area Code	M	TS 24.008 [26], sec.10.5.1.12.3, TS 25.413 [9], sec.9.2.3.7, TS 32.642 [24] sec. 6.3.10
	CellID	Cell ID	M	TS 25.331 [25] sec.10.3.2.2
	CSG Cell Info	<detail per Rel.8 RRC spec>	O	Applicable to Rel.8 compliant cell only.

#### 6.1.2.2.3 GSM Cell Information

The information in the following table is reported by the HNB to the HMS for each GSM cell detected.

**Table 6.1.2.3-1. GSM Cell Information.**

Information		Description / Note	Presence	3GPP Reference
RF information	ARFCN	Channel number	M	TS 32.652 [27] sec. 6.3.5
	BCCHRSSI	RSSI of the BCCH carrier.	M	TS 32.652 [27] sec. 6.3.5
	BSIC	Base Station ID Code	M	TS 32.652 [27] sec. 6.3.5
Broadcast Information	MCC	Mobile Country Code	M	TS 32.652 [27] sec. 6.3.5
	MNC	Mobile Network Code	M	TS 32.652 [27] sec. 6.3.5
	LAC	Location Area Code	M	TS 32.652 [27] sec. 6.3.5
	RAC	Routing Area Code	M	TS 32.652 [27] sec. 6.3.5
	CellID	Cell ID	M	TS 32.652 [27] sec. 6.3.5

### 6.1.2.3 GNSS Location Information

This information consists of, at minimum, latitude and longitude detected by the GNSS receiver (e.g. GPS receiver), if the HNB implementation includes this functionality.

### 6.1.2.4 Broadband Connection Information

This information consists of the information associated with the broadband connection (e.g. DSL) the HNB is connected with: 1) public IP address assigned to the RGW (e.g. DSL-GW/router), and 2) line identifier to which the RGW is connected with (e.g. DSL line ID) as seen on the broadband service provider. These are applicable only when this information is available to the HNB, and only when the resulting location information is at least as accurate as location determination based on macro-cell coverage information, whether or not there is macro-cell coverage available at the location of the HNB (e.g. as determined by clause 6.1.2.2 above).

## 6.1.3 HNB-GW Discovery

During the HNB-GW Discovery procedure, the HMS provides the HNB with 3 identities as shown in the following table. The information may be either IP address or FQDN to be resolved by DNS.

**Table 6.1.3-1. HNB-GW Discovery Information.**

Parameter	Description / Note	Presence	3GPP Reference
Serving HMS ID	One or more IDs may be provided	M	
Serving SeGW ID	One or more IDs may be provided	M	
Serving HNB-GW ID	One or more IDs may be provided	M	

## 6.1.4 HNB Provisioning

### 6.1.4.1 General

During the HNB Provisioning procedure, the HMS transfers the HNB configuration information to the HNB. This includes 3 types of parameters:

1. CN level parameters
2. RAN level parameters
3. RF level parameters

NOTE: The HNB may have auto-configuration capabilities, such that the HMS sends a list/range of values to the HNB, which selects (and returns to HMS) a single value, also based on the information collected measuring the radio environment. The HMS may also provide control parameters of the auto-configuration process.

#### 6.1.4.2 CN Level Parameters

**Table 6.1.4.2-1. CN Level Parameters.**

Parameter	Description / Note	Presence	3GPP Reference
PLMN Type	"GSM-MAP" or "ANSI-41"	M	TS 25.331 [25] sec. 10.3.1.12
MCC	Mobile Country Code	M	TS 24.008 [26], TS 32.642 [24] sec. 6.3.8
MNC	Mobile Network Code	M	TS 24.008 [26], TS 32.642 [24] sec. 6.3.8
LAC	Location Area Code (one or more LACs may be provided)	M (Note 1)	TS 24.008 [26] sec.10.5.1.3, TS 32.642 [24] sec. 6.3.9
SAC	Service Area Code	M	TS 25.413 [9] sec.9.2.3.9, TS 32.642 [24] sec. 6.3.9
T3212	Periodic LAU timer (CS domain)	M	TS 24.008 [26] sec. 10.5.1.12.2
ATT	Attach-detach allowed (CS domain)	M	TS 24.008 [26] sec. 10.5.1.12.2
RAC	Routing area code (PS domain) (one or more RACs may be provided)	M (Note 1)	TS 24.008 [26] sec.10.5.1.12.3, TS 25.413 [9] sec.9.2.3.7, TS 32.642 [24] sec. 6.3.9
NMO	Network Mode of Operation (Gs i/f)	M	TS 24.008 [26] sec. 10.5.1.12.3
Equivalent PLMN ID	List of one or more equivalent PLMN ID (MCC + MNC)	O (Note 2)	TS 24.008 [26] sec. 10.5.1.13
Allowed IMSI list	For access control or membership verification purposes.	O (Note 3)	TS 24.008 [26] sec. 10.5.1.4
CSG Cell Info	CSG Capability Indication, CSG Id, in case the Cell is CSG capable <any further detail per Rel.8 RRC spec>	M	Applicable to Rel.8 compliant cell only.
HNB Location Information	Location information (Geographical coordinates, Uncertainty code)	O	TS 25.413 [9] sec. 9.2.3.11
SAI for broadcast	Service Area for broadcast	M	TS 25.419 [12] sec. 9.2.11
Note 1:	May be a list/range of values in case the HNB has auto-configuration capabilities.		
Note 2:	This information is operator-dependent based on its circumstance.		
Note 3:	ACL is an optional function at HNB. This information is provided if this function is enabled in the HNB.		

## 6.1.4.3 RAN Level Parameters

Table 6.1.4.3-1. RAN Level Parameters.

Parameter		Description	Presence	3GPP Reference
RNCID for HNB		RNC ID used by HNB	M	TS 32.642 [24] sec. 6.3.8
Cell ID		28-bit "Cell ID" in SIB3	M	TS 25.331 [25] sec. 10.3.2.2
HSPA related	HSflag	Whether HSDPA/HSUPA is used or not	O	TS 32.642 [24] sec. 6.3.9
HCS related	UseOfHCS HCSPrio QHCS		M	TS 25.331 [25] sec. 10.3.7.47 and 10.3.7.12, TS 32.642 [24] sec. 6.3.9
Cell selection / reselection related	Quality measure QqualMin QqualMin-offset QrxlevMin QrxlevMin-offset Sintrasearch Sintersearch SsearchRAT SsearchHCS Tresselections UETxPwrMaxRACH QHyst1	CPICH Ec/N0 or RSCP if Ec/N0 is used  if RSCP is used	O (Note 1)	TS 25.331 [25] sec. 10.3.2.3 and 10.3.2.4, TS 32.642 [24] sec. 6.3.9, TS 25.304 [29]
Intra Freq Measurement Related	Filter coefficient Measurement quantity for freq quality estimate Hysteresis for event 1x Threshold for event 1x TimetoTrigger for event 1x Weighting factor for event 1x Reporting Range Triggering Condition	Filter coefficient CPICH Ec/No, CPICH RSCP, or pathloss "x" in 1x includes applicable events from 1A to 1J	O (Note 1)	TS 25.331 [25] sec. 10.3.7.38 and 10.3.7.39
Inter-Freq Measurement Related	Filter coefficient Measurement quantity for freq quality estimate Hysteresis for event 2x Threshold for event 2x TimetoTrigger for event 2x Weighting factor for event 2x	Filter coefficient CPICH Ec/No, CPICH RSCP "x" in 2x includes applicable events from 2A to 2F	O (Note 1)	TS 25.331 [25] sec. 10.3.7.18 and 10.3.7.19
Inter-RAT Measurement Related	Filter coefficient BSIC verification required Hysteresis for event 3x Threshold for event 3x TimetoTrigger for event 3x Weighting factor for event 3x	Filter coefficient "required" / "not required" "x" in 3x includes applicable events from 3A to 3D	O (Note 1)	TS 25.331 [25] sec. 10.3.7.29 and 10.3.7.30
RRC related	N30x, N31x T30x, T31x, T320	RRC constants RRC timers	O (Note 1)	TS 25.331 [25] sec. 10.3.3.43 and 10.3.3.44
Neighbour list (UTRA Intra-Freq cell info list)	RNCID C-Id LAC RAC PSC	Defined for each intra-freq cells C-Id is either 12 or 16 bits depending on RNCID length.	O (Note 2)	TS 32.642 [24] sec. 6.3.10, TS 25.401 [4] sec. 6.1, TS 25.413 [9] sec. 9.2.1.28
Neighbour list (UTRA Inter-Freq cell info list)	RNCID C-Id LAC RAC UARFCN (DL)	Defined for each inter-freq cells C-Id is either 12 or 16 bits depending on RNCID length	O (Note 2)	TS 32.642 [24] sec. 6.3.10, TS 25.401 [4] sec. 6.1, TS 25.413 [9] sec.



	PSC			9.2.1.28
Neighbour list (GERAN cell info list)	CellID BSIC BandIndicator BCCHARFCN	Defined for each inter-RAT cells (assume GSM cell only).	O (Note 2)	TS 32.652 [27] sec. 6.3.5
Note 1:	Marked as optional based on the operator preference on the extent of provisioning that the HMS performs to the HNB vs. the level of autonomy that HNB has for auto-configuration. In case this IE is absent, default value is assumed (additional implication is that HNB has a set of default parameter values).			
Note 2:	Marked as optional due to several implications: 1) there may be no suitable neighbour cell available based on the RF scanning procedure described earlier, 2) based on operator deployment policy (e.g. dedicated RF channel for HNB layer vs. macro layer), and 3) operator preference on the extent of provisioning that the HMS performs to the HNB vs. the level of autonomy that HNB has for auto-configuration. Regarding 3) above, this may include capabilities such as the HMS to add or remove neighbour cells initially detected by the HNB during the radio environment scanning process, and the HNB to extend the received Neighbour list based on auto-configuration capabilities.			

## 6.1.4.4 RF Level Parameters

**Table 6.1.4.4-1. RF Level Parameters.**

Parameter	Description / Note	Presence	3GPP Reference
UARFCN (DL)	Frequency channel number (one or more UARFCNs may be provided)	O (Note 1)	TS 25.101 [28] sec. 5.4, TS 25.104 [23] sec. 5.4, TS 32.642 [24] sec. 6.3.11
PSC	Primary scrambling code (one or more PSCs may be provided)	O (Note 1)	TS 32.642 [24] sec. 6.3.11
MaxHNBTxPower	Maximum allowed Tx power of the HNB.	O (Note 1)	TS 25.104 [23] sec. 6.2, TS 32.642 [24] sec. 6.3.9
MaxULTxPower	The parameter defines the maximum transmission power level a UE can use on PRACH.	O (Note 1)	TS 25.101 [28] sec. 6.2, TS 32.642 [24] sec. 6.3.9
P-CPICHPower	Transmission power of Primary CPICH (DL config). This may be either a specific value or a range (min / max) of values.	O (Note 1)	TS 32.642 [24] sec. 6.3.11
P-SCHPower	Primary SCH power offset (DL config)	O (Note 1)	TS 32.642 [24] sec. 6.3.11
S-SCHPower	Secondary SCH power offset (DL config)	O (Note 1)	TS 32.642 [24] sec. 6.3.11
BCHPower	BCH power offset (DL config)	O (Note 1)	TS 32.642 [24] sec. 6.3.11
AICHPower	AICH power offset (DL config, BCCH info)	O (Note 1)	TS 25.331 [25] sec. 10.3.6.3, TS 32.642 [24] sec. 6.3.11
PICHPower	PICH power offset (DL config, BCCH info)	O (Note 1)	TS 25.331 [25] sec. 10.3.6.50, TS 32.642 [24] sec. 6.3.9
PCHPower	PCH power offset (DL config, BCCH info)	O (Note 1)	TS 32.642 [24] sec. 6.3.9
FACHPower	FACH power offset (DL config, BCCH info)	O (Note 1)	TS 32.642 [24] sec. 6.3.9
Note 1: Marked as optional based on the operator preference on the extent of provisioning that the HMS performs to the HNB vs. the level of autonomy that HNB has for auto-configuration. In case this IE is absent, it is assumed that the HNB will derive the suitable value based on its auto-configuration capability. In case this IE is a list/range of values, the HNB will choose a single value based on its auto-configuration capability. UARFCN UL may be automatically determined by the HNB upon UARFCN DL (basing on standard duplex configuration and country-specific spectrum allocation).			

## 6.2 O&M for HNB-GW

No requirements have been identified.

---

## 7 Iuh interface protocol structure

### 7.1 General

Figure 7.2-1 shows the Control Plane and the User Plane protocol structures over the Iuh interface. For the control plane, the HNBAP protocol provides the signalling service between the HNB and the HNB-GW required to fulfil the functions described in TS 25.469 [3].

RUA provides the signalling service between the HNB and the HNB-GW that is required to fulfil the functions described in TS 25.468 [2].

The payload protocol identifier (PPI) field in SCTP (IETF RFC 4960 [6]) is set to the value 19 assigned by IANA for use with the RUA protocol. In addition, the value 20 is assigned for the PPI for HNBAP. The value 31 is assigned for the PPI for SABP. The multiplexing protocol as specified in TS 25.444 [8] provides the means to multiplex CS user plane on the uplink.

The destination port number field in SCTP (IETF RFC 4960 [6]) is set to the value 29169 assigned by IANA for setup of the common SCTP association in HNBAP, RUA and SABP.

For Iurh there shall be an SCTP association for each direct Iurh interface between HNBs. For operation via the HNB-GW there shall be a single SCTP association common to all Iurh interface instances. This association shall be separate from the Iuh SCTP association established between the HNB and the HNB-GW.

The payload protocol identifier (PPI) field in IETF RFC 4960 [6] is set to the value 42 registered by IANA for the use with the RNA protocol.

The destination port number field in IETF RFC 4960 [6] is set to the value 25471 assigned by IANA for setup of the SCTP association in RNA.

### 7.2 Iuh

Figure 7.2-1 shows the protocol structure for Iuh, following the structure described in TS 25.401 [4].

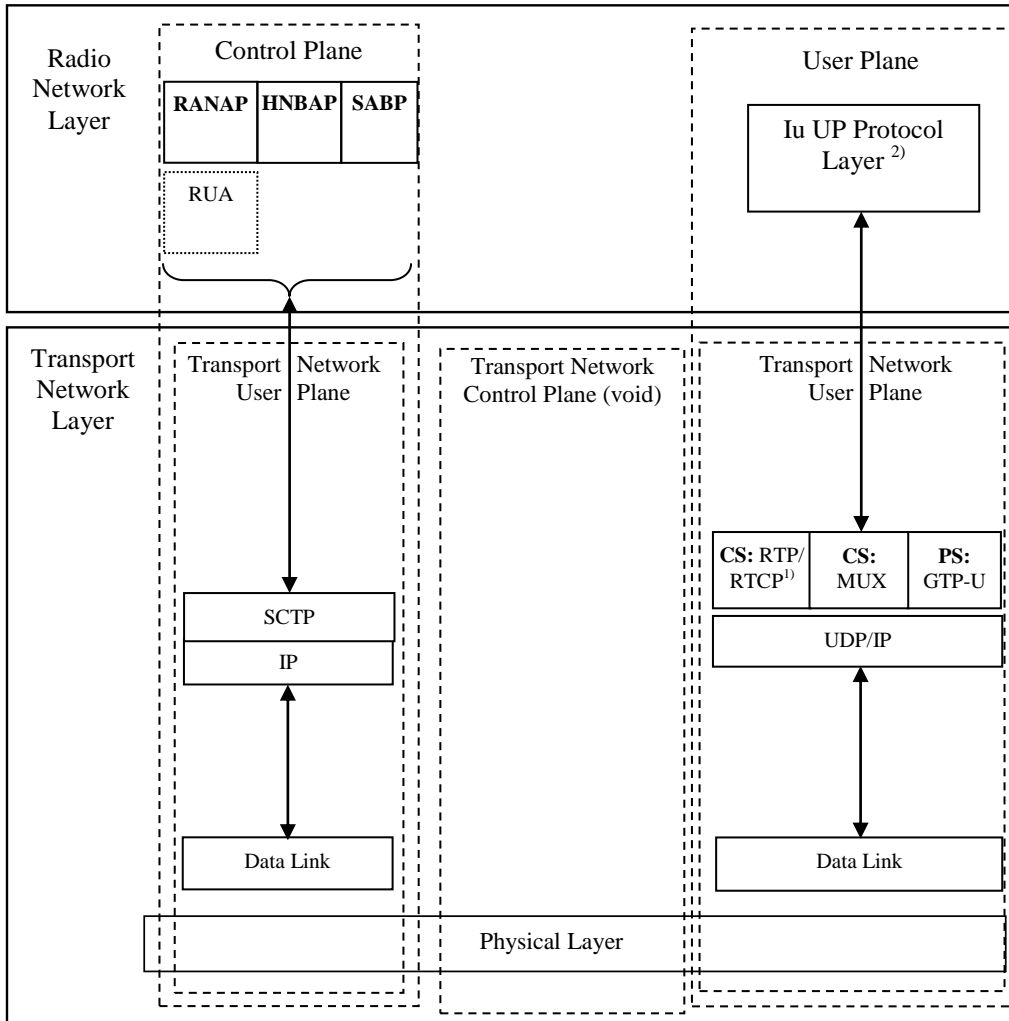

Note 1) RTCP is optional.

Note 2) Iu UP is terminated in CN and HNB only (i.e. not in the HNB GW)

**Figure 7.2-1. I<sub>uh</sub>-Interface Protocol Stack.**

### 7.3 I<sub>urh</sub>

Figure 7.3-1 shows the protocol structure for I<sub>urh</sub>, following the structure described in TS 25.401 [4].

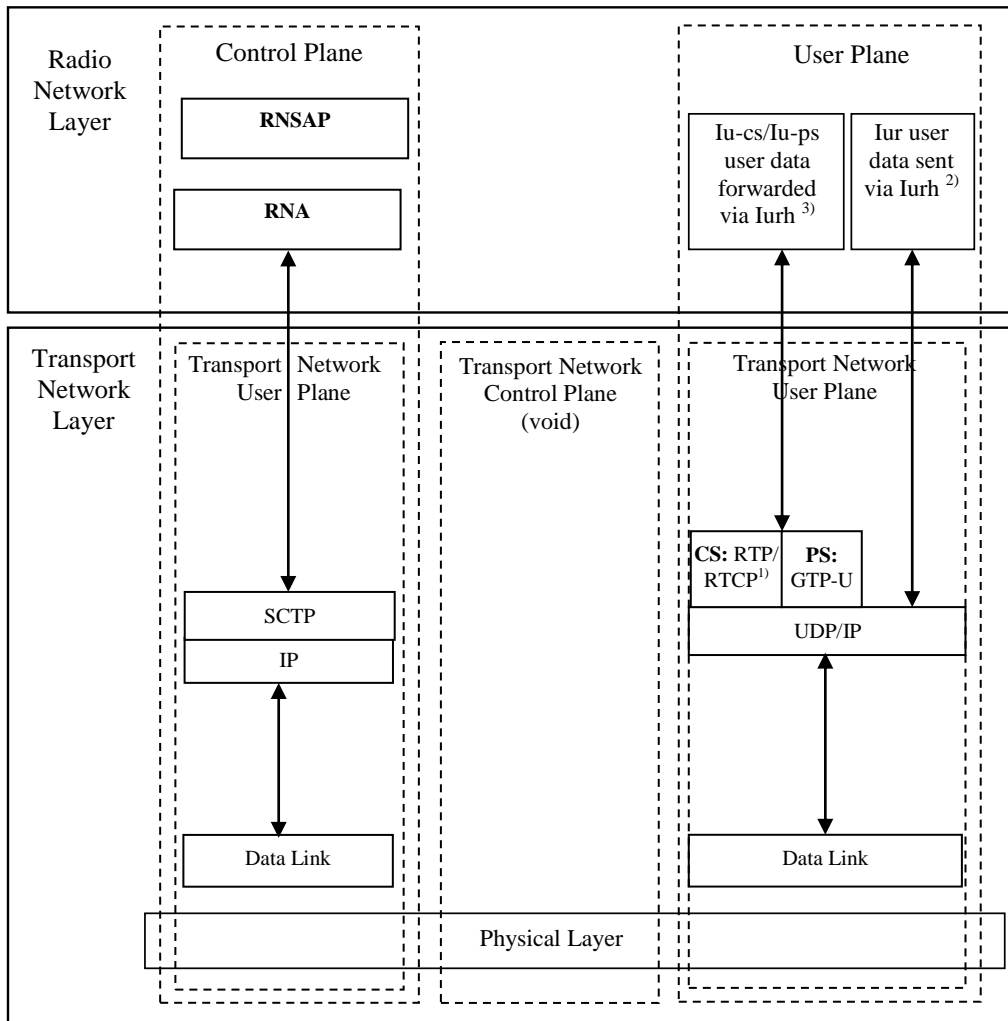

**Figure 7.3-1. Iurh-Interface Protocol Stack.**

NOTE 1: RTCP is optional

NOTE 2: as specified in TS 25.425 [21] and TS 25.427 [22]

NOTE 3: as specified in TS 25.415 [17]

### 7.3.1 Iurh-Interface Control Plane Protocol Stack

The figures below show the control plane protocol stack for Iurh both for direct connectivity between HNBs and for connectivity between a HNB and a macro RNC via the HNB-GW .

Figure 7.3.1-1 shows the control plane protocol stack for the direct Iurh-connectivity option between HNBs.

NOTE: The option that Iurh signalling traffic may be routed on IP level via the HNB-GW is depicted by the optional protocol entity boxes within the routing function.

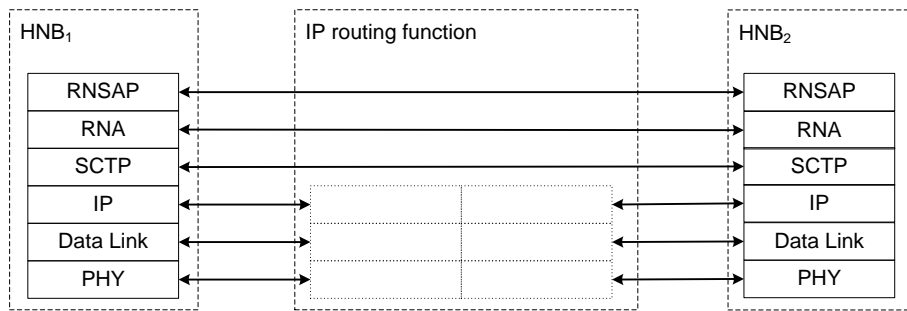

**Figure 7.3.1-1. Iurh-Interface Protocol Stack for direct Iurh-connectivity between HNBs.**

Figure 7.3.1-2 shows the control plane protocol stack for the Iurh connectivity between HNBs via the HNB-GW.

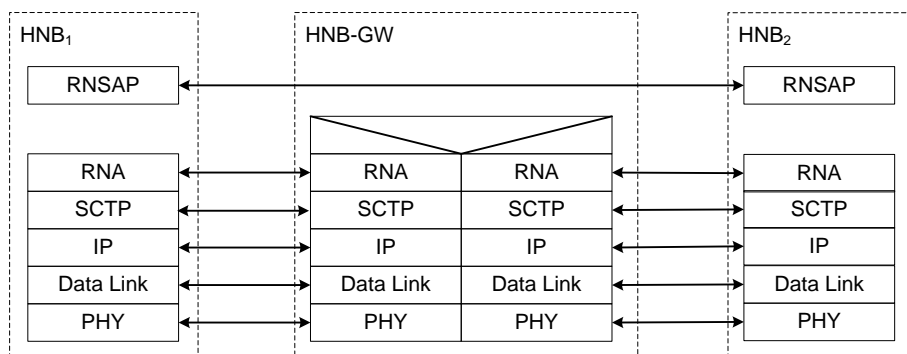

**Figure 7.3.1-2. Iurh-Interface Protocol Stack for Iurh-connectivity between HNBs via the HNB-GW.**

Figure 7.3.1-3 shows the control plane protocol stack for connectivity between a HNB and a macro RNC via the HNB-GW.

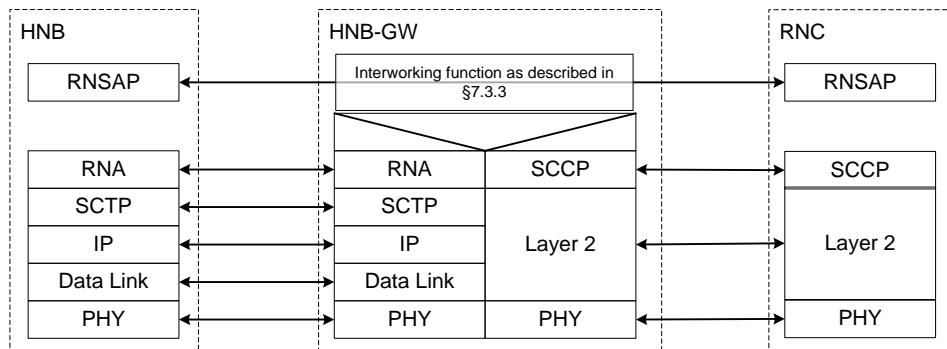

**Figure 7.3.1-3: Iurh-Iur Interfaces Protocol Stack for connectivity between a HNB and a macro RNC via the HNB-GW.**

## 7.3.2 Usage of the services provided by RNSAP User Adaptation Layer (RNA)

### 7.3.2.1 General

This section describes usage of RNA for Iurh connectivity between HNBs.

RNA supports the transport of any RNSAP signalling messages between HNBs.

RNA provides a connection-oriented data transfer service and a connectionless data transfer service.

A signalling connection established by means of RNA is denoted by a single Context Id, which is unique within both involved nodes (see TS 25.471 [19] for further details).

RNA supports direct Iurh-connectivity and Iurh-connectivity via the HNB-GW .

### 7.3.2.2 Iurh Signalling Connection Establishment

#### 7.3.2.2.1 Direct Iurh connectivity



**Figure 7.3.2.2.1-1: Signalling Connection Establishment – Direct Iurh-connectivity.**

If the Sending HNB wants to send an RNSAP message to the Receiving HNB for which a dedicated Iurh signalling connection has to be established, it issues an RNA:CONNECT message containing the Iurh Context Id, the RNSAP PDU, the Senders HNB RNL Identity and the Receivers HNB RNL Identity. The Reception of the RNA:CONNECT message at the Receiving HNB completes the signalling connection establishment.

#### 7.3.2.2.2 Iurh signalling connection establishment via the HNB-GW

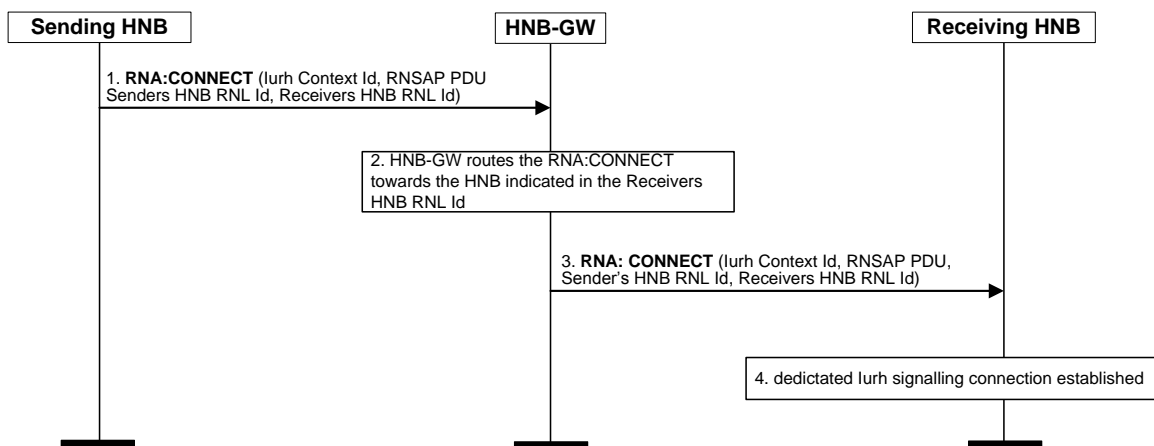
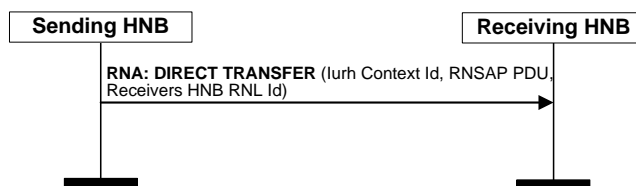

**Figure 7.3.2.2.2-1: Signalling Connection Establishment – Iurh connection via HNB-GW.**

1. If the Sending HNB is configured for Iurh-connectivity via the HNB-GW, and wants to send an RNSAP message to the Receiving HNB for which a signalling connection has to be established, it issues an RNA:CONNECT message containing the Iurh Context Id, the RNSAP PDU, the Senders HNB RNL Identity and the Receivers HNB RNL Identity.
2. The HNB-GW identifies the signalling interface to which the RNA message shall be routed by Receivers HNB RNL Identity as received from the Sending HNB.
3. The HNB-GW issues an RNA:CONNECT message with identical content as received from the Sending HNB to the Receiving HNB.
4. Reception of the RNA:CONNECT message by the Receiving HNB completes the signalling connection establishment for the Receiving HNB.

### 7.3.2.3 Transport of RNSAP signalling messages via an established lurch signalling connection

#### 7.3.2.3.1 Direct lurch connectivity



**Figure 7.3.2.3.1-1: Transport of RNSAP messages via an established lurch signalling connection – Direct lurch connectivity.**

If Sending HNB, directly lurch connected to the Receiving HNB, wants to send an RNSAP message to Receiving HNB for which a connection oriented data transfer service is already established, it issues an RNA:DIRECT TRANSFER message to the Receiving HNB which contains the lurch Context Id, the RNSAP PDU and the Receivers HNB RNL Identity.

#### 7.3.2.3.2 lurch connectivity via the HNB-GW

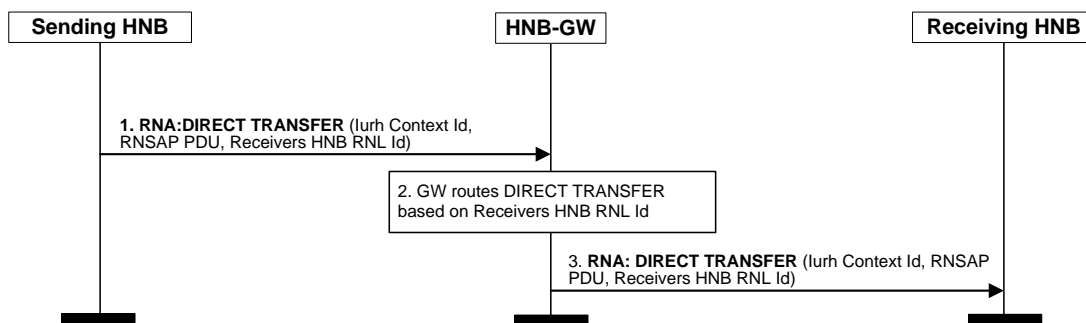
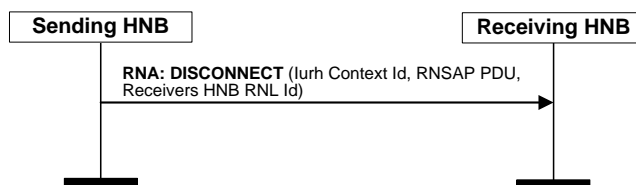

**Figure 7.3.2.3.2-1: Transport of RNSAP messages via an established lurch signalling connection – lurch connectivity via the HNB-GW.**

If the Sending HNB, lurch connected to the Receiving HNB via the HNB-GW, wants to send an RNSAP messages via the established signalling connection, it issues an RNA:DIRECT TRANSFER message to the HNB-GW, providing the Receivers HNB RNL Identity which enables the HNB-GW to route the RNSAP message to the Receiving HNB.

### 7.3.2.4 Release of a Signalling Connection

#### 7.3.2.4.1 Direct lurch connectivity



**Figure 7.3.2.4.1-1: Release of an lurch signalling connection – Direct lurch-connectivity.**

If the Sending HNB, directly lurch-connected to the Receiving HNB, wants to release an established signalling connection towards the Receiving HNB, it sends an RNA:DISCONNECT message, which includes the lurch Context Id and the Receivers HNB RNL Identity and may include an RNSAP PDU. Reception of the DISCONNECT message by the Receiving HNB completes the release of the lurch signalling connection.



7.3.2.4.2 lurh connectivity via the HNB-GW

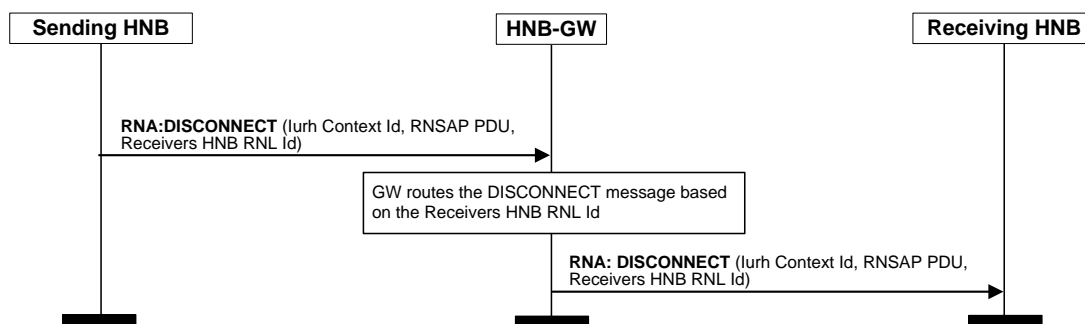

Figure 7.3.2.4.2-1: Release of an Iurh signalling connection – Iurh connectivity via the HNB-GW.

If the Sending HNB, Iurh connected to the Receiving HNB via the HNB-GW, wants to release the signalling connection towards Receiving HNB, it sends an RNA:DISCONNECT message, which includes the Iurh Context Id and the Receivers HNB RNL Identity and may include an RNSAP PDU. The HNB-GW routes the DISCONNECT message based on the Receivers HNB RNL Identity. Reception of the DISCONNECT message by Receiving HNB completes the release of the signalling connection.

7.3.2.5 Transport of RNSAP signalling messages via the connectionless data transfer service

7.3.2.5.1 Direct Iurh connectivity



Figure 7.3.2.5.1-1: Connectionless data transfer – Direct Iurh-connectivity.

If the Sending HNB wants to send an RNSAP PDU to the Receiving HNB, for which no Iurh signalling connection is necessary, it issues an RNA:CONNECTIONLESS TRANSFER message containing the RNSAP PDU, the Senders HNB RNL Identity and the Receivers HNB RNL Identity.

7.3.2.5.2 Iurh connectivity via the HNB-GW

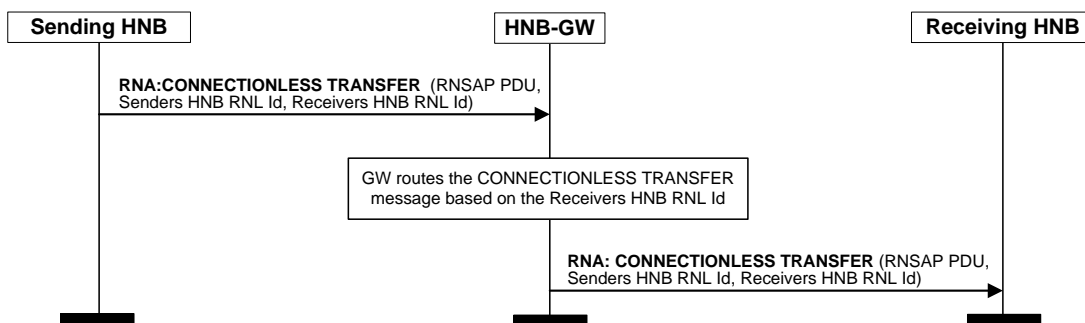

Figure 7.3.2.5.2-1: Connectionless data transfer – Iurh connectivity via the HNB-GW.

If the Sending HNB wants to send an RNSAP PDU to the Receiving HNB, for which an Iurh signalling connection is not necessary, it issues an RNA:CONNECTIONLESS TRANSFER message containing the RNSAP PDU, the Senders and the Receivers HNB RNL Identities to the HNB-GW, which routes the RNA message based on the Receivers HNB RNL Identity. The Receiving HNB is able to identify the sending HNB by the Senders HNB RNL Identity.

### 7.3.3 Interworking between the RNSAP User Adaptation Layer (RNA) and the Signalling Connection Control Part (SCCP)

#### 7.3.3.1 General

This section describes usage of RNA and SCCP for connectivity between a HNB and a macro RNC via HNB-GW.

RNL signalling between an RNC and a HNB-GW utilises services provided by the SCCP (ITU-T Rec. Q.711 [32] / ITU-T Rec. Q.712 [33]/ ITU-T Rec. Q.713 [34]/ ITU-T Rec. Q.714 [35]) as defined for Iur interface signalling transport between two RNCs (see 3GPP TS 25.420 [31]), since the HNB-GW is seen as an RNC from RNCs being connected via the Iur interface to it.

The Interworking functions at the HNB-GW deal with:

- extracting or inserting respective RNL related addressing information on the Iurh connection or on the Iur connection of the RNC-HNB signalling connectivity,
- on Iurh, RNL related addressing information carried on RNA within the *Receivers HNB RNL Identity* IE and the *Senders HNB RNL Identity* IE,
- on Iur, RNL related addressing information is carried within RNSAP;
- for connection oriented signalling, performing appropriate mapping between RNA level and SCCP level;
- respective routing of RNSAP messages based on available address information.

In general, (i) Iur connectivity between the HNB-GW and the RNC is established by configuration, while (ii) the Iurh connectivity between the HNB and the HNB-GW is performed via the Iurh setup procedure.

The following subclauses describe the interworking between RNA and SCCP at the HNB-GW.

### 7.3.3.2 Establishment of signalling connection over Iurh and Iur connections between HNB and RNC via HNB-GW

#### 7.3.3.2.1 HNB initiated

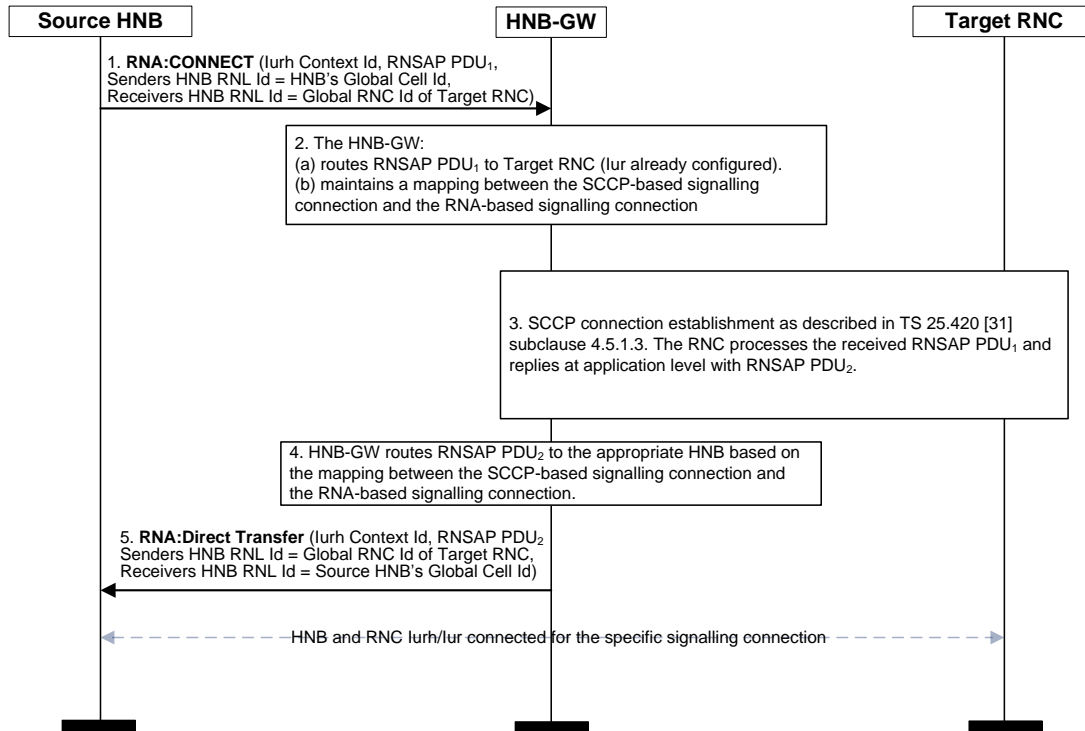

**Figure 7.3.3.2.1-1: Establishment of signalling connection over Iurh and Iur connections between HNB and RNC via HNB-GW – HNB Initiated.**

1. If the Source HNB is configured for Iurh-connectivity via the HNB-GW, and wants to send an RNSAP message to the Target RNC for which signalling connection over Iurh and Iur connections has to be established, it issues an RNA:CONNECT message containing the Iurh Context Id, the RNSAP PDU<sub>1</sub>, the Source HNB RNL Identity and the Target RNC RNL Identity.
2. The HNB-GW identifies the signalling interface to which the RNA message shall be routed by the Target RNC's RNL Identity as received from the Source HNB and maintains a mapping between the RNA-based signalling connection and the SCCP-based signalling connection for the HNB-RNC end-to-end.
3. The HNB-GW sends RNSAP PDU<sub>1</sub> to the Target RNC and the Target RNC sends back RNSAP PDU<sub>2</sub> (see TS 25.420 [31] subclause 4.5.1.3).
4. The HNB-GW routes the RNSAP PDU<sub>2</sub> towards the Source HNB.
5. The HNB-GW sends an RNA:Direct Transfer message, including RNSAP PDU<sub>2</sub> received from the Target RNC.

## 7.3.3.2.2 HNB initiated – Refusal from RNC

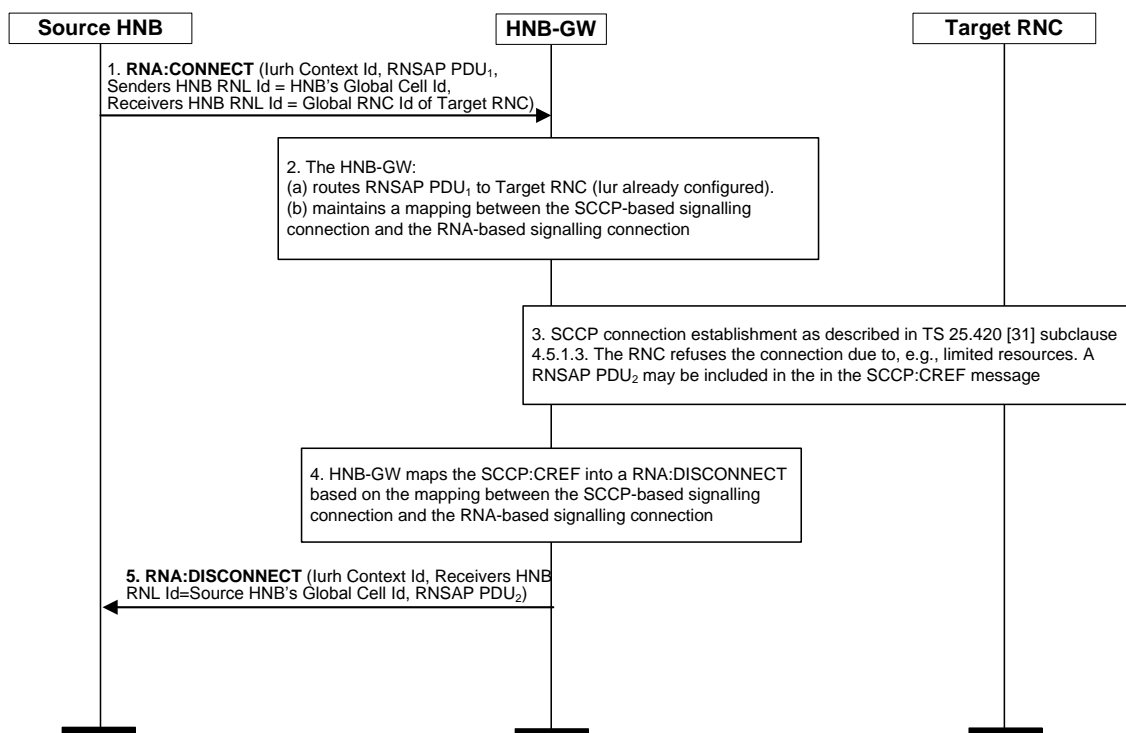

**Figure 7.3.3.2.2-1: Establishment of signalling connection over Iurh and Iur connections between HNB and RNC via HNB-GW – HNB Initiated with refusal from RNC.**

1. If the Source HNB is configured for Iurh-connectivity via the HNB-GW, and wants to send an RNSAP message to the Target RNC, it issues an RNA:CONNECT message containing the Iurh Context Id, the RNSAP PDU<sub>1</sub>, the Source HNB RNL Identity and the Target RNC RNL Identity.
2. The HNB-GW identifies the signalling interface to which the RNA message shall be routed by the Target RNC's RNL Identity as received from the Source HNB and maintains a mapping between the RNA-based signalling connection and the SCCP-based signalling connection for the HNB-RNC end-to-end communication.
3. The HNB-GW sends RNSAP PDU<sub>1</sub> to the Target RNC as received from the HNB via SCCP:Connection Request and the Target RNC refuses the connection request (see TS 25.420 [31] subclause 4.5.1.3).
4. The HNB-GW maps the SCCP:CREF message into an RNA:DISCONNECT.
5. The HNB-GW sends an RNA:DISCONNECT message, including the optional RNSAP PDU<sub>2</sub> if received from the Target RNC.

7.3.3.2.3 RNC initiated

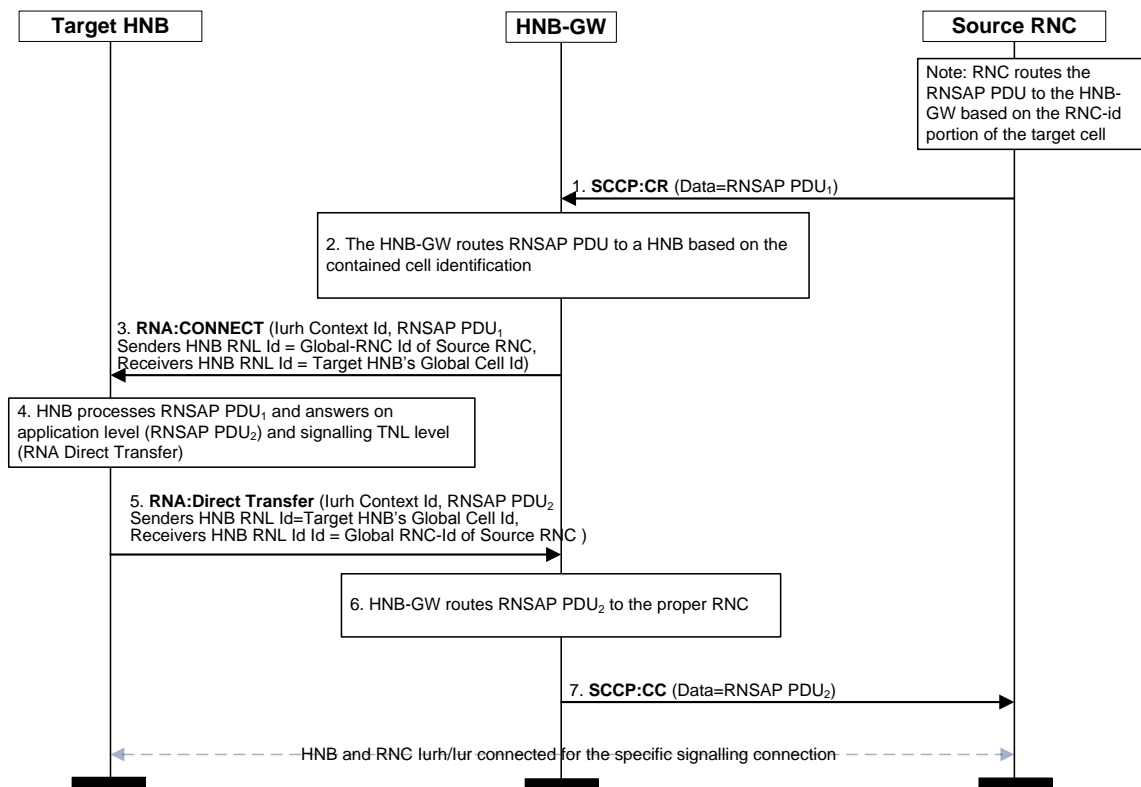
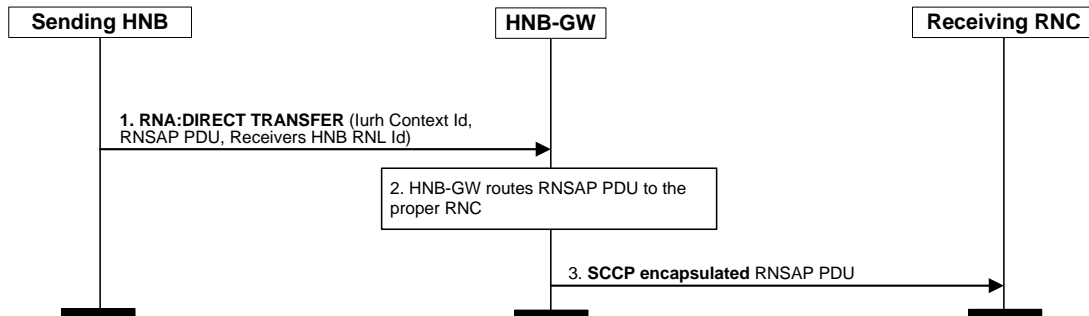

**Figure 7.3.3.2.3-1: Establishment of signalling connection over Iurh and Iur connections between HNB and RNC via HNB-GW – RNC Initiated.**

1. The HNB-GW is seen by Source RNC as a (configured) neighbour RNC. Any signalling towards a target cell with a respective RNC-Id-prefix is sent to the HNB-GW. In this case the RNC triggers the SCCP connection establishment as described in TS 25.420 [31] subclause 4.5.1.3.
2. The HNB-GW has to be able (i) to extract the Target HNB RNL Id from the (Global) Cell-Id indicated in the initiating RNSAP PDU and (ii) to maintain a mapping between the SCCP-based signalling connection and the RNA-based signalling connection for the HNB-RNC end-to-end communication.
3. The HNB-GW sends an RNA:CONNECT message towards the appropriate HNB including the Iurh Context Id generated at Step 2, RNSAP PDU<sub>1</sub> received from the RNC and the Global Ids of RNC and HNB.
- 4-7. At the reception of the RNA:CONNECT message, the Target HNB processes RNSAP PDU<sub>1</sub>, generates the response RNSAP PDU<sub>2</sub>. The HNB replies then with an RNA :Direct Transfer message including the new RNSAP PDU<sub>2</sub> and the RNC and HNB Ids. The HNB-GW will forward such pieces of information to the RNC (TS 25.420 [31] subclause 4.5.1.3).

### 7.3.3.3 Transport of RNSAP signalling messages via signalling connection established over lurh and lur connections

#### 7.3.3.3.1 HNB initiated

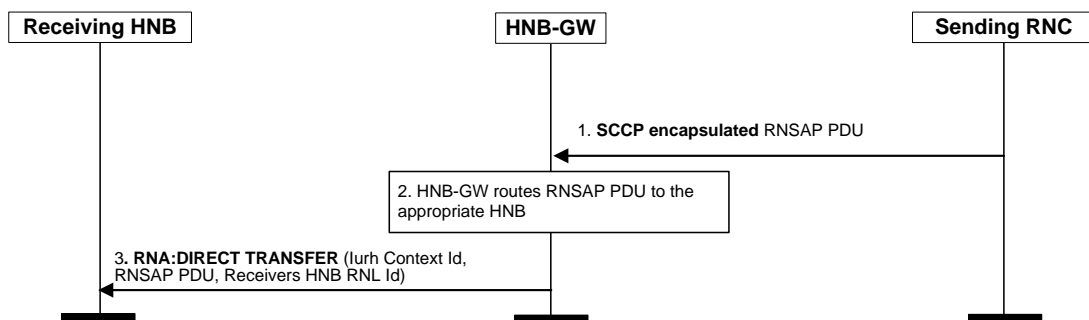

**Figure 7.3.3.3.1-1: Transport of RNSAP messages via signalling connection over lurh and lur connections – HNB initiated.**

If the Sending HNB wants to send an RNSAP message to the Receiving RNC for which a connection oriented data transfer service is already established, it issues an RNA:DIRECT TRANSFER message towards the HNB-GW which contains the lurh Context Id, the RNSAP PDU and the Receivers HNB RNL Identity.

The HNB-GW will forward the RNSAP PDU to the Receiving RNC within an SCCP message.

#### 7.3.3.3.2 RNC initiated



**Figure 7.3.3.3.1-1: Transport of RNSAP messages via signalling connection over lurh and lur connections – RNC initiated.**

If the Sending RNC wants to send an RNSAP message to the Receiving RNC for which a connection oriented data transfer service is already established, it will send to the HNB-GW the RNSAP PDU within an SCCP message.

The HNB-GW will then generate an RNA:DIRECT TRANSFER message and will route the RNSAP PDU to the correct HNB.

### 7.3.3.4 Release of signalling connection over lurh and lur Connections

#### 7.3.3.4.1 HNB initiated

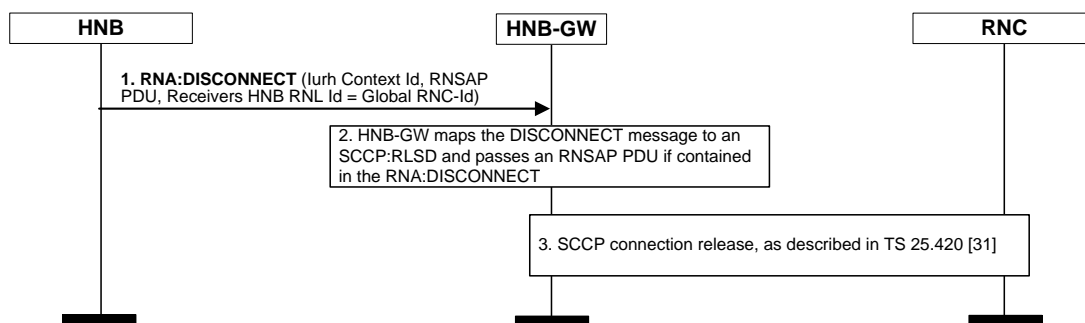

**Figure 7.3.3.4.1-1: Release of established signalling connection over lurh and lur connections – HNB initiated.**

If an HNB wants to release a signalling connection previously established over Iurh and Iur connections previously established towards an RNC, it sends an RNA:DISCONNECT message, which includes the Iurh Context Id and the Receivers HNB RNL Identity (i.e., the Global RNC Id) and may include an RNSAP PDU. The HNB-GW maps the RNA:DISCONNECT message to an SCCP:Released message and triggers the SCCP connection release procedure defined in TS 25.420 [31] subclause 4.5.1.4.

#### 7.3.3.4.2 RNC initiated

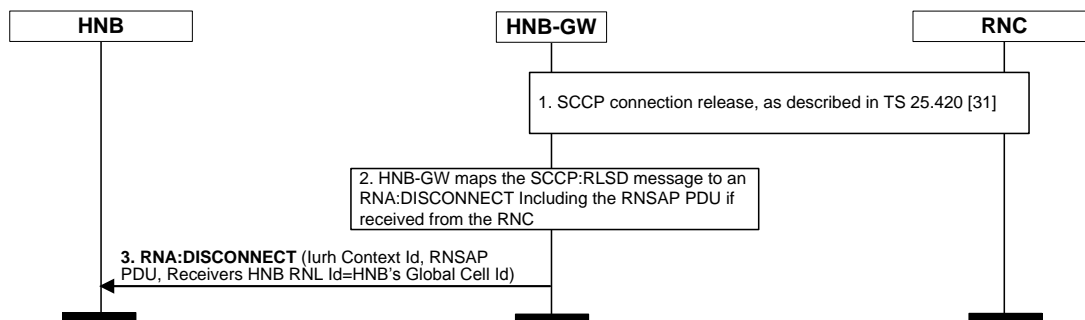

**Figure 7.3.3.4.2-1: Release of established signalling connection over lurh and lur connections – RNC initiated.**

If an RNC wants to release a signalling connection previously established over Iurh and Iur signalling connections previously established towards an HNB, it behaves as described in TS 25.420 [31] subclause 4.5.1.4.

The HNB-GW maps the SCCP:RLSD to an RNA:DISCONNECT message and forwards it to the HNB. This last message includes the proper Iurh Context Id, the Receivers HNB RNL Identity (i.e., the HNB Global Id) and an RNSAP PDU, if previously received from the RNC.

### 7.3.3.5 Transport of RNSAP signalling messages via the connectionless data transfer service

#### 7.3.3.5.1 HNB initiated

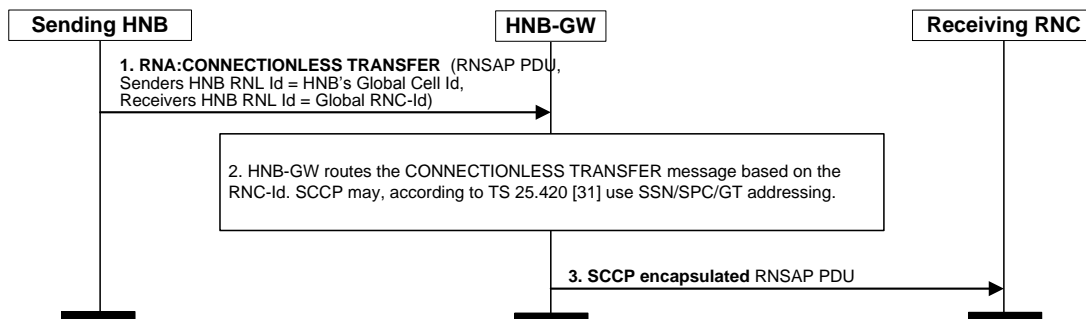
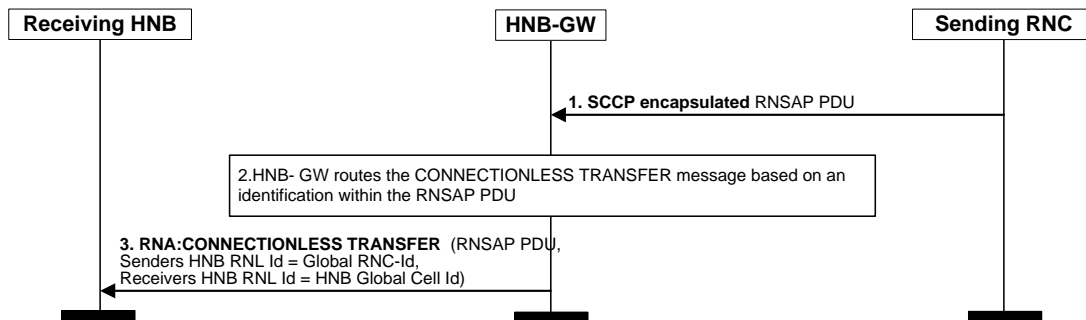

**Figure 7.3.3.5.1-1: Connectionless data transfer over lurh and lur connections – HNB initiated.**

If the Sending HNB wants to send in a connectionless manner an RNSAP PDU to the HNB -GW for the Receiving RNC, it issues an RNA:CONNECTIONLESS TRANSFER message containing the RNSAP PDU, the Senders and the Receivers HNB RNL Identities.

The HNB-GW then generates and routes the RNSAP PDU within an SCCP message towards the Receiving RNC.

#### 7.3.3.5.2 RNC initiated



**Figure 7.3.3.5.2-1: Connectionless data transfer over lurh and lur connections – RNC initiated.**

If the Sending RNC sends an RNSAP PDU to the HNB-GW for the Receiving HNB, the HNB-GW has to be able to extract the receiving HNB’s RNL address from received RNSAP PDU. Then the HNB-GW issues an RNA:CONNECTIONLESS TRANSFER message containing the RNSAP PDU, the Senders and the Receivers HNB RNL Identities to the receiving HNB. The Receiving HNB is able to identify the sending RNC by the Senders HNB RNL Identity.



## 8 Enhanced Interference Management

### 8.1 General

There is a type of interference which may be considered: 1) Interference from HNB to Macro.

Scenarios are listed in Table 8.1-1.

**Table 8.1-1. Interference scenarios.**

Scenario	Aggressor	Victim	Type of interference
1	HNB UE (UL)	Macro NB	Interference from HNB to Macro
2	HNB (DL)	Macro UE	*applicable to co-channel deployment scenario

### 8.2 Mitigation of interference from HNB to Macro

#### 8.2.1 Interference from HNB UE (UL) to Macro NB

The scenario involves:-

1. Adaptively limiting the HNB UE's maximum UL Tx Power in connected mode possibly using HNB UE measurement and calculating the path loss between HNB UE and Macro NB.

#### 8.2.2 Interference from HNB (DL) to Macro UE

The scenario involves:-

1. Redirecting unauthorized UE to another carrier possibly based on uplink access attempts by unauthorised UE.

2. Adjusting HNB's DL CPICH Tx Power adaptively either temporarily or over long term possibly based on uplink access attempts by unauthorised UE.

---

## Annex A (informative): Implementation of CN functions within the HNB-GW for support of inter-HNB intra-HNB-GW SRNS Relocation

### A.1 Scope

The implementation option described in this Annex will not be evolved or maintained/corrected by 3GPP in the current Release or future Releases of the 3GPP specifications. The mechanism in subclause 5.7 is the mechanism that shall be maintained, and for which evolution within 3GPP is applicable.

### A.2 General

This Section describes an implementation variant where CN functions of SRNS Relocation are implemented within the HNB-GW in order to hide intra-HNB-GW inter-HNB active mode mobility from the CN.

From a HNB perspective the HNB-GW appears as a CN node (one node per CN domain) providing all necessary protocol functions for SRNS Relocation (Hard Handover), from a CN node perspective, the HNB-GW appears as an RNC serving the inter-HNB relocations as intra-RNC mobility.

The following sub-sections describe the respective mechanisms. The RANAP messages are exchanged over the Iuh interface from the Source-HNB to the HNB-GW and from the HNB-GW to the Target-HNB using appropriate RUA encapsulation.

In this implementation the Iu UP protocol is still terminated in the CN and HNB (Figure 7.2-1), but there is an Iu UP Interworking function (A.10) residing in the HNB-GW. This implementation variant supports SRNS Relocation between HNBs supporting the same RFC combinations if the HNB supports only Iu UP v1 and SRNS Relocation between all HNBs supporting Iu UP v2.

### A.3 Mobility procedure

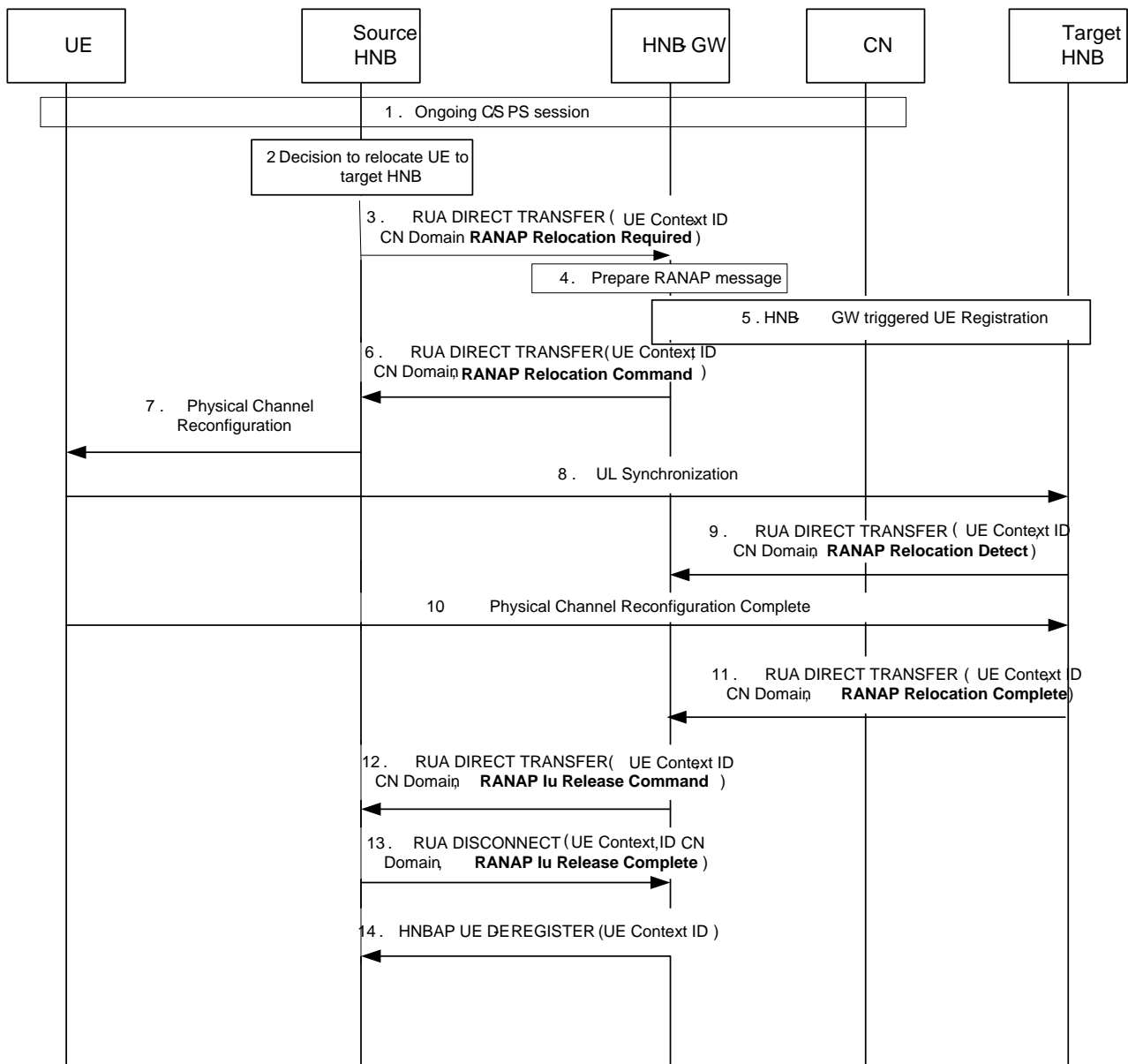

**Figure A.3-1: Inter-HNB Inter-HNB-GW SRNS Relocation – Implementation of CN functions for SRNS Relocation within the HNB-GW.**

1. The UE has established an active CS/PS session to the CN via the source HNB and HNB-GW.
2. At some point, the source HNB makes a decision to relocate the UE session.
3. The source HNB triggers relocation of the UE session by sending the RANAP *Relocation Required* message encapsulated in the RUA *Direct Transfer* message to the HNB-GW. The target RNC-Id and target Cell-Identity information along with relocation information are included by the source HNB in the RANAP *Relocation Required* message.
4. The HNB-GW constructs the RANAP RELOCATION REQUEST using the stored RAB Parameters and parameters received from source HNB. The RANAP message also includes the HNB-GW UL TNL information for each RAB to be setup at the target HNB.
5. Steps for HNB-GW Triggered UE Registration are executed between the HNB-GW and the HNB. The IuhUPIF function handles the CS user plane establishment in the HNB-GW. The RANAP message from the target HNB includes the target HNB DL TNL information for each RAB to be setup. In case the target HNB decides to use the alternative RAB parameters and indicates the same in the RANAP RELOCATION ACKNOWLEDGE message, the HNB-GW rejects the relocation towards the target HNB and redirects original relocation request

towards the CN node as in subclause 5.9.

In this phase, HNB-GW may begin bi-casting DL traffic to the source and target HNB.

6. The HNB-GW constructs the appropriate RANAP *Relocation Command* message and routes the RANAP message encapsulated in the RUA *Direct Transfer* message to the source HNB.
  - 7-11. The rest of the relocation procedure continues as shown in the corresponding steps in the above figure. When the relocation is detected in HNB-GW, the HNB-GW switches the user plane from the source HNB to the target HNB.
  12. The HNB-GW upon getting an indication that the UE has been successfully relocated to the target HNB triggers the Iu release procedure towards the source HNB by sending a RUA encapsulated RANAP *Iu Release Command* message.
  13. The source HNB acknowledges the Iu release procedure to the HNB-GW by sending a RUA encapsulated RANAP *Iu Release Complete* message.
- NOTE: Steps 2 to 13, as appropriate, are repeated for the second CN domain when present with the following exception. There is only one Context Id allocated to the UE regardless of the number of signalling domains relocated.
14. The HNB-GW deregisters the UE from the source HNB. The source HNB releases the resources assigned to the UE and deletes all stored context information associated with the UE.

## A.4 Iuh Control Plane Aspects

The HNB-GW processes and forwards some of the connection-oriented RANAP messages, related to RAB Management, Data Volume Reporting, UE Tracing, Location Reporting, Security and Iu UP Initialisation.

## A.5 Iuh user plane aspects

The HNB-GW processes and forwards all the user plane packets between the HNB and the CN and performs the switching of the user plane between the source and the target HNB.

## A.6 RAB management Functions

The establishment, modification or release of a RAB is performed between the HNB and the CN as specified in TS 25.413 [9]. However, the HNB-GW stores the RAB parameters of each established RAB as signalled via respective on the RANAP messages during RAB establishment, modification and SRNS Relocation.

## A.7 Data Volume Reporting

The data volume reporting function is used to report the volume of unsuccessfully transmitted DL data of PS RABs to the CN. If the CN has initiated the data volume report then in order to continue data volume reporting after the finalisation of the SRNS Relocation, the HNB-GW includes the Data Volume Reporting Indication in the RANAP RELOCATION REQUEST message towards the target HNB. The HNB-GW accumulates data volume reports from the different HNBs involved in subsequent inter-HNB intra-HNB-GW SRNS Relocations and reports the final value to the SGSN at RAB release.

## A.8 UE Tracing

This feature allows tracing of various events related to the UE and its activities. The HNB-GW stores the Trace related RANAP parameters exchanged in the RANAP signalling messages. In order to continue UE tracing in the target HNB during and after SRNS Relocation, the HNB-GW sends the stored RANAP CN INVOKE TRACE encapsulated in the RUA DIRECT TRANSFER message towards the target HNB after step 5 (see subclause 5.11.2).

## A.9 Location reporting function

The positioning function performs the determination of the geographical position for an UE. The location reporting function transfers the positioning information between the UTRAN and the CN triggered by the RANAP Location Reporting Control from the CN. If the RANAP Location Reporting Control procedure is initiated with “*Request Type*” indicated as “to report upon change of Service area”, the HNB-GW sends the Location Report if there is a change in SA due to SRNS Relocation. Also, the HNB GW sends the stored RANAP LOCATION REPORTING CONTROL encapsulated in the RUA DIRECT TRANSFER message towards the target HNB after step 5 (see subclause 5.11.2) if Location Reporting Control procedure continues after relocation.

## A.10 Security Functions

The radio interface is ciphered/integrity protected upon request of the Core Network. The ciphering/ integrity protection is done within UTRAN at the HNB. However, the HNB-GW stores the ciphering and integrity protection related RANAP parameters exchanged in the UE dedicated RANAP signalling messages. The HNB-GW includes the stored ciphering/integrity protection information in the Relocation Request message to the target HNB.

## A.11 Iuh Framing Protocol Interworking Function (IuhUPIF)

### A.11.1 Introduction

The CS user plane traffic on the Iuh interface (between HNB and HNB-GW) carried using the Iu UP framing protocol as defined in the TS 25.415 [17] UTRAN Iu interface user plane protocols. The HNB Iu UP entity follows the procedures and principles defined in the Iu UP framing protocol specification (TS25.415 [17] UTRAN Iu interface user plane protocols). Most of the Iu UP PDUs will be transferred by the HNB-GW without any processing. However, the HNB-GW will perform certain functionalities that could be implemented by an IuhUPIF (Iuh user plane interworking function) in the HNB-GW as described below.

The IuhUPIF is the functional entity responsible for aligning or mapping control procedures (including RFCIs, frame numbers etc) on the separate UP interfaces. The IuhUPIF determines if the two UP configurations (at the HNB and CN) are identical and thus the UP PDUs may be passed transparently. If the IuhUPIF determines that the two UP configurations are not identical it applies the necessary mapping.

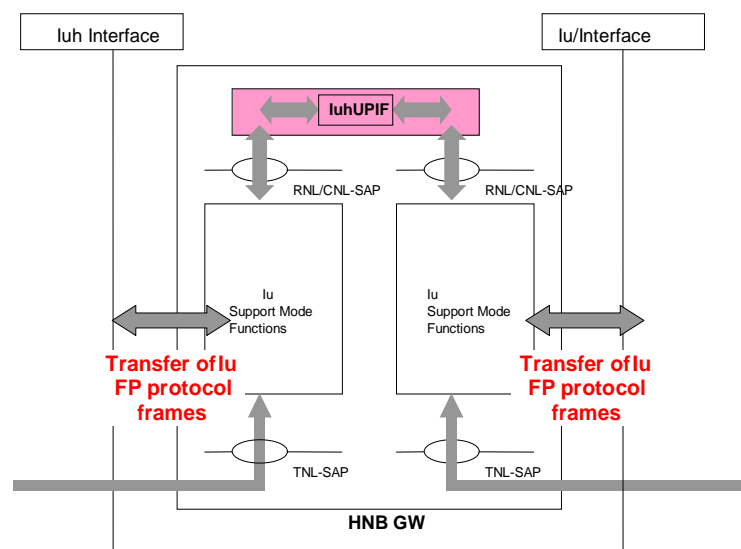

Figure A.11.1-1. The Iuh Framing Protocol Interworking Function.

## A.11.2 CS User Plane handling during the Initial CS RAB setup

During the CS RAB setup, the HNB allocates the RAB Subflows combination indicator for the SDU formats (SDU formats are sent to the HNB in the RANAP RAB ASSIGNMENT message). The allocation is then sent in the Iu Framing Initialisation PDU by the HNB in the user plane. For further details see TS 25.413 [9] and TS 25.415 [17].

Upon reception of the RFCI values in the Iu UP Initialisation Frame (Iu UP PDU type 14 from the HNB) during the call establishment, the HNB-GW stores "UL RFCI vector". The first subflow of the initialisation corresponds to the Initial Rate control i.e. indicate the highest rate for the first speech mode to be used in the direction of the Initialisation acknowledgement frame. The HNB-GW forwards the Iu UP Initialisation frame towards the CN according to TS 25.415 [17] without any change to the received Iu UP PDU from the HNB. Upon reception of the Iu UP ACK/NACK PDU, the HNB-GW forwards it towards the HNB.

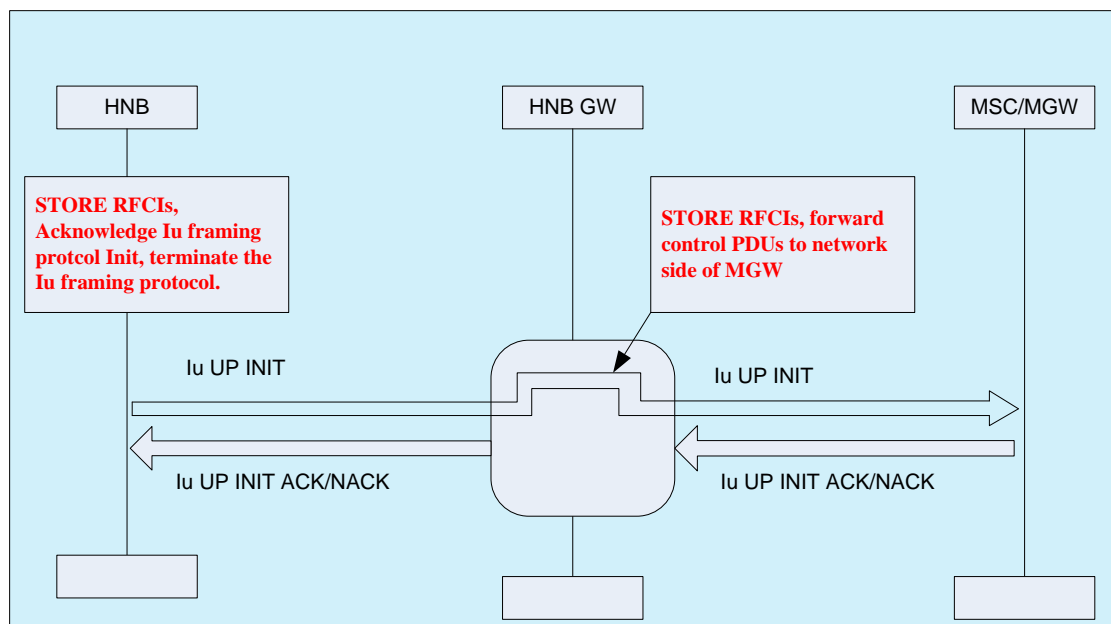
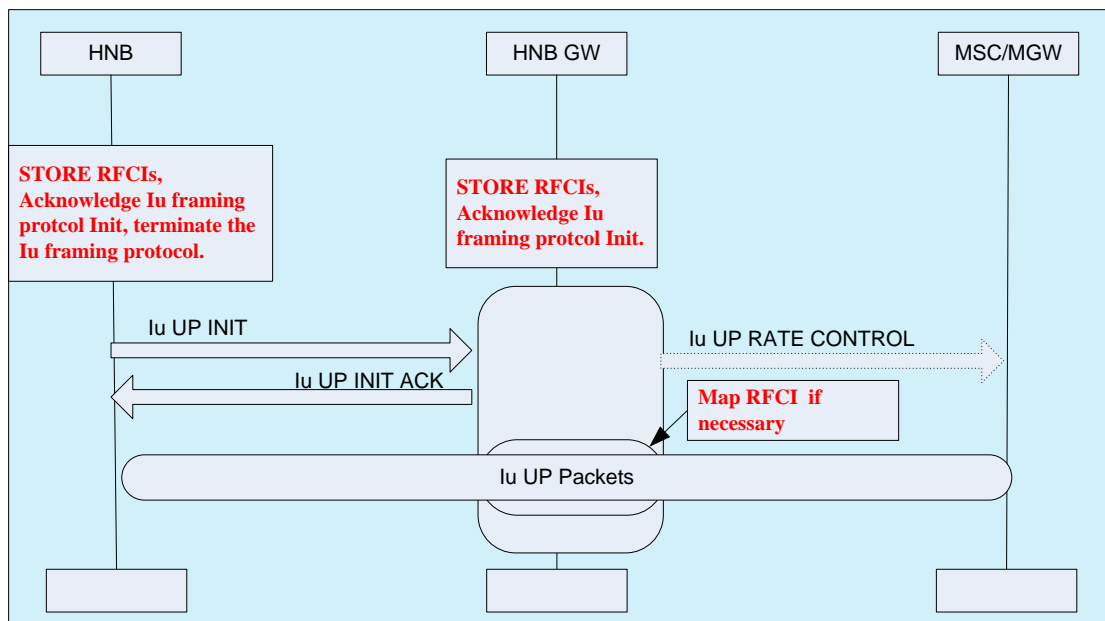

Figure A.11.2-1. IU UP Handling during the Initial call setup.

## A.11.3 CS User Plane handling after the finalisation of SRNS Relocation

During the SRNS Relocation, as part of the RANAP Relocation Resource Allocation procedure, the target HNB performs the user plane initialisation. The (Target) HNB allocates the RAB Subflows combination indicator(s) for the each SDU formats (SDU formats are sent to the HNB in the RANAP RELOCATION REQUEST message). The allocation is then sent in the Iu Framing Initialisation PDU by the HNB in the user plane. For further details see TS 25.413 [9] and TS 25.415 [17].



**Figure A.11.3-1. IU UP Handling after SRNS Relocation.**

At reception of an IU UP Initialisation Frame (Iu UP PDU type 14) from the Target HNB, the HNB-GW stores received RFCI indexes (per data rate) in the form of ordered sequence (received in the initialisation PDU) as “UL RFCI Vector” and send the Initialisation acknowledgment to the target HNB. The HNB-GW does not perform the forwarding of the IuUP initialisation on the Iu interface. The HNB-GW checks whether the received RFCI allocations match the stored RFCI allocation for the same bearer established with the source HNB. The HNB-GW performs the following functions:

- RFCI Mapping function: If the allocated RFCI index (s) does not match with the existing RFCI index(s) for the corresponding data rates, then the HNB-GW performs the RFCI Mapping function. That is, for every subsequent Iu UP frame upon the relocation, the HNB-GW maps the RFCI indices of the incoming side (from the HNB) to the corresponding RFCI indicates to the outgoing side (towards the MSC that is already stored in the HNB-GW) and vice versa.
- In case Iu UP version 1, if the maximum rate indicated by the target HNB in the Iu UP INIT is different from the current used maximum rate then the HNB-GW initiates a Rate Control PDU indicating the new maximum rate to the MSC.

## A.11.4 FQC

The HNB-GW (IuhUP IF) does not handle the FQC included in the UP frames. The value included in the Iu UP frame is passed to the peer not without any modification.

## A.11.5 Frame number

The frame number indicated by the peer node (i.e. Iu or Iuh) on the receiving side is forwarded unmodified to lower layer on the sending side.

## A.11.6 Time alignment Procedure:

When a HNB-GW (IuhUP IF) entity receives a time Alignment Command over the Iu or Iuh interface, it is relayed unmodified to the other peer node.

## A.11.7 Rate Control Procedure

When an HNB-GW (IuhUP IF) entity receives a Rate Control over the Iu or Iuh interface, it forwards to the other peer node) with ‘RFCI Mapping’ where appropriate.

### A.11.8 Payload

When a HNB-GW (IuhUP IF) entity receives the payload SDUs, the received SDUs is forwarded unmodified to the either side (HNB or HNB-GW) with ‘RFCI Mapping’ where appropriate.

### A.11.9 Iu UP Re-Initialisation

When an HNB-GW (IuhUP IF) entity receives a Iu UP Initialisation from the CN, it stores the “DL RFCI Vector” and then forward it to the HNB without any modification in the RFCIs. Upon reception of the Iu UP ACK/NACK PDU, the HNB-GW forwards it towards the CN.

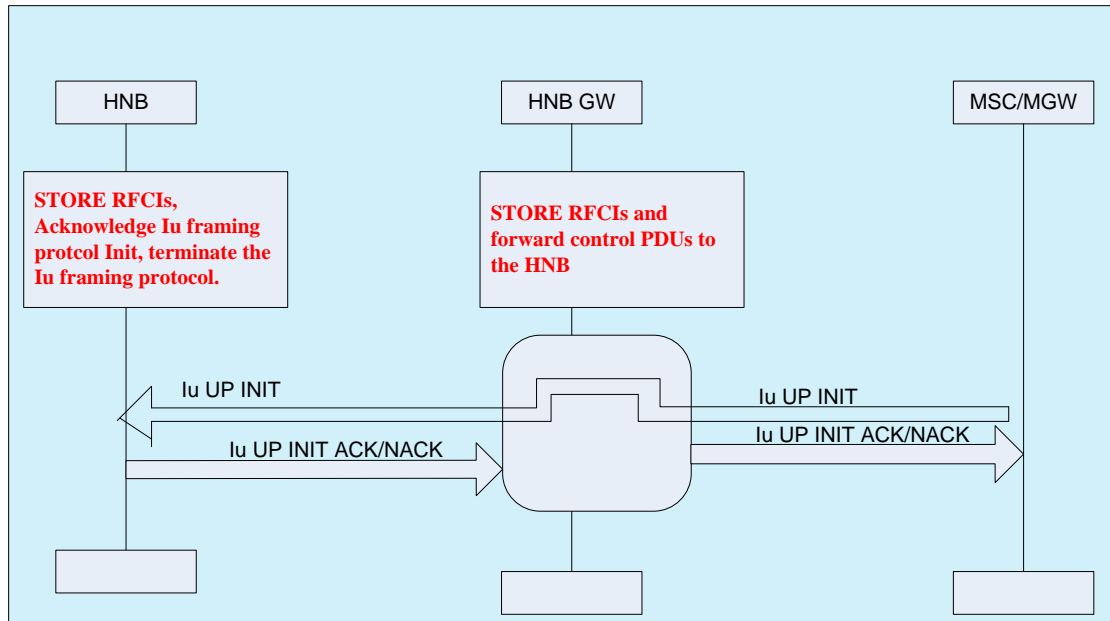

Figure A.11.9-1. IU UP Re- Initialisation.



# Annex B (informative): Deployment Architecture

## B.1 Direct Iurh connectivity between HNBs

The reference model shown in Figure B.1-1 below illustrates an HNB access network with direct Iurh connectivity.

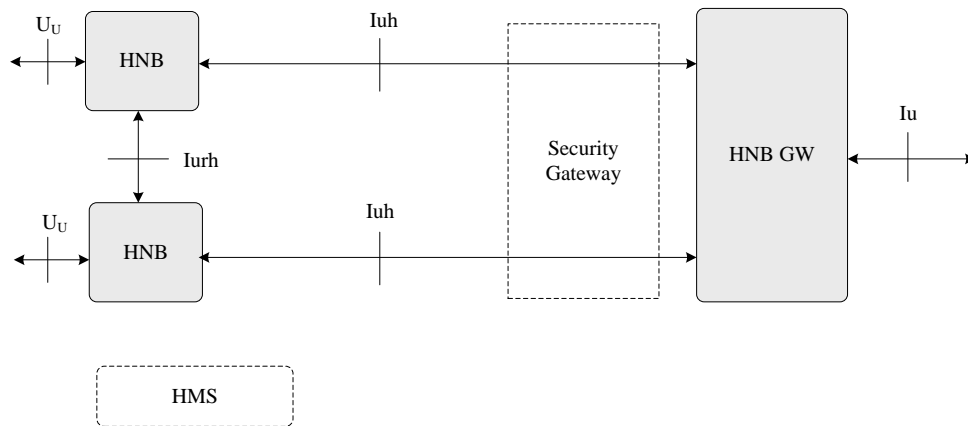

**Figure B.1-1. HNB access network deploying direct Iurh connectivity.**

An alternative HNB access network configuration deploying the Iurh interface transported via the Security Gateway is shown in Figure B.1-2.

NOTE: If the Security Gateway and the HNB-GW are co-located then the co-located node should support IP routing.

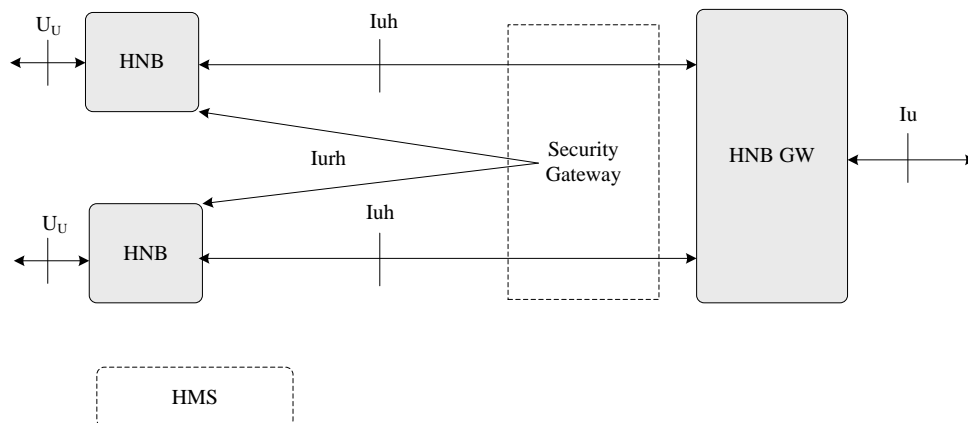

**Figure B.1-2. HNB access network deploying Iurh connectivity via a Security Gateway.**

An alternative arrangement with the Iurh interface transported via the Security Gateway and the HNB-GW is shown in Figure B.1-3. The HNB-GW provides transport routing functionality.

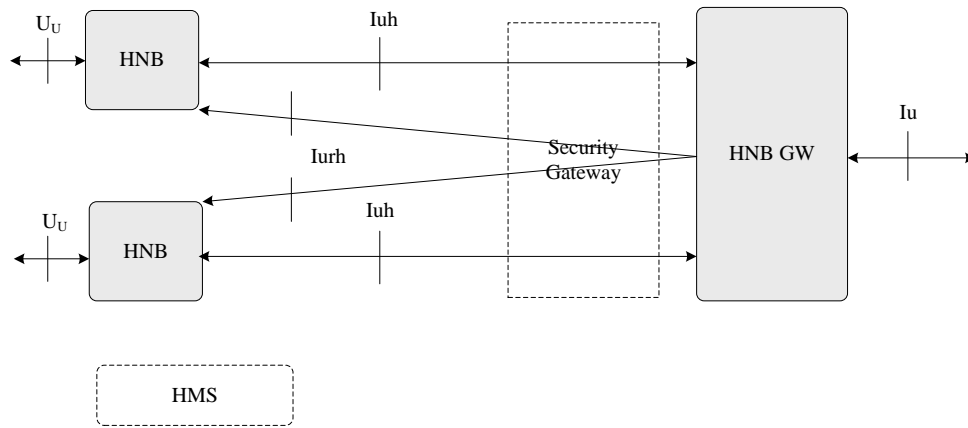

Figure B.1-3. HNB access network deploying lurch connectivity via the HNB-GW.

## Annex C (informative): Implementation of PSC Disambiguation for Support of Legacy UE Mobility from RNC to HNB

### C.1 Scope

In some HNB deployments the limited number of PSCs available to be allocated to HNBs may cause PSC ambiguity. This may result in the inability of identifying, at the source macro RNC, a unique target HNB corresponding to a PSC reported by a Legacy UE (i.e., UEs not capable of SI acquisition).

In this informative annex two solutions for PSC disambiguation are described.

The implementation options described in this Annex are not intended to be evolved in the 3GPP specifications.

### C.2 Disambiguation at the RNC

This implementation option can be split in two different steps:

Step 1: At first, during previous HNB to RNC mobility, the RNC builds a local database of necessary information concerning neighbouring cells with PSC confusion (e.g., neighbouring cells PSCs, Cell IDs, Observed Time Difference (OTD)). This local database is built/maintained via handover preparation signalling. The HNB shall include the full Measurement Report and the source cell ID in the handover preparation signalling, and the target RNC collects incoming data and adds/updates OTD information to its database.

Step 2: In a second phase, during RNC to HNB mobility (hand-in), the RNC uses the information previously gathered in order to disambiguate the target HNB in case of a certain PSC is reused in a given (target) area.

#### C.2.1 Step 1: Construction of HNB database in the RNC

Figure C.2.1-1 depicts the first step of this implementation option. It consists in the RNC building the database of HNBs during HNB to RNC mobility. Such database includes PSCs, Cell IDs and Assistance data (e.g., OTD).

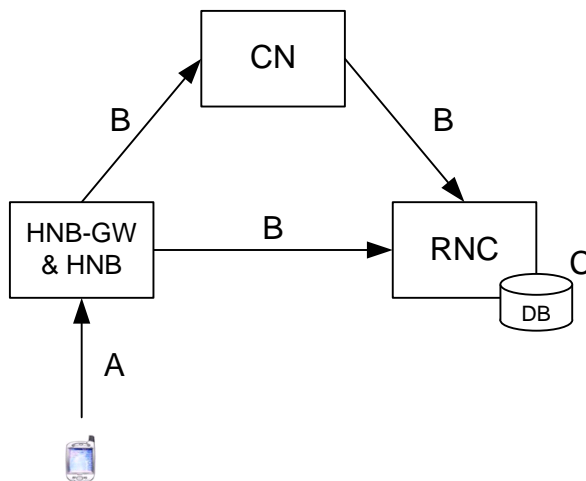

**Figure C.2.1-1: Step 1 – Example of RNC constructing database of HNBs during HNB to RNC mobility.**

This first step can be split in the following sub-steps:

- A. The UE under control of the HNB is configured to provide measurement reports, including OTD data.

Such measurement report, e.g., can be carried within an RRC:Measurement Report to the HNB and, subsequently, to the target RNC via handover preparation procedures.

- B. The HNB initiates relocation towards macro cells, by including the source cell identity and full Measurement Report in the *Source RNC to Target RNC Transparent Container*;
- C. The Macro RNC collects incoming data and adds/updates OTD information to its database.

At this stage, the Macro RNC has built a database with all necessary information for future RNC to HNB relocation (hand-in).

### C.2.2 Step 2: PSC disambiguation executed by the RNC during RNC to HNB hand-in

Figure C.2.2-1 depicts the second step of implementation option. The RNC, during RNC to HNB mobility (hand-in), can disambiguate the target HNB on the basis of the information collected in the target cells database.

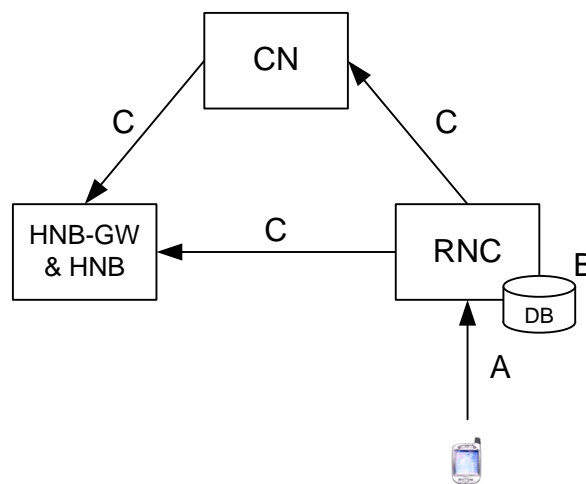

**Figure C.2.2-1: Step 2 – Example of PSC disambiguation at RNC during RNC to HNB relocation.**

As shown in the figure above, the second step of this implementation option consists of the following sub-steps:

- A. The RNC enables the normal measurement reporting to a “shared” PSC in the area;
- B. In case of shared target PSC and if the UE is not SI reading capable, the RNC checks the cells reported in the measurement report, calculates the  $\Delta$ OTD information based on the measurement report and finds the best match in the database created in Step 1;
- C. The RNC initiates relocation towards the selected target HNB as per normal mobility procedures.

### C.3 Disambiguation at the HNB-GW

This solution allows the HNB-GW to identify the target HNB based on the source Cell ID and the measurements including OTD which are reported by the UE during the handover as shown in Figure C.3-1. The procedure includes two parts:

- Construction and Update of HNB Timing Information ( $\Delta$ OTD) Database at the HNB-GW.
- Target Cell Disambiguation at the HNB-GW during handover to a HNB connected to this HNB-GW.

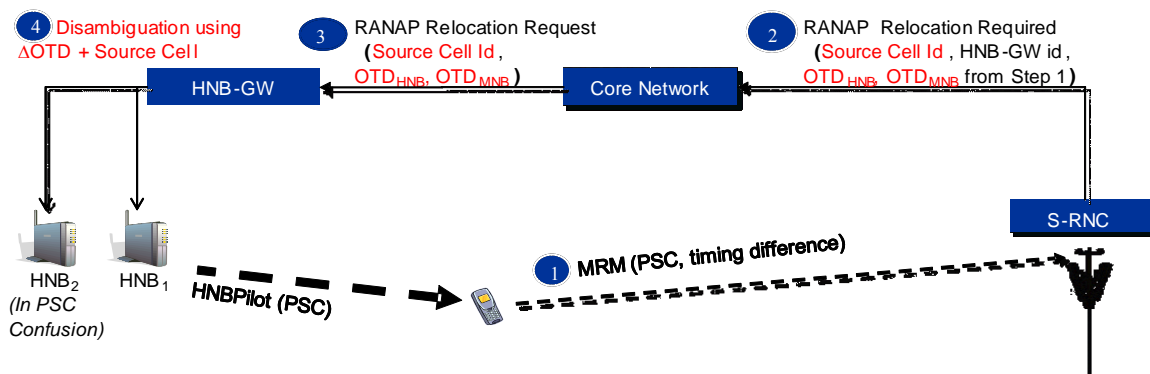

Figure C.3-1:  $\Delta$ OTD based disambiguation at the HNB-GW.

### C.3.1 Construction and Update of $\Delta$ OTD Database at the HNB-GW

$\Delta$ OTD = (OTD<sub>HNB</sub> - OTD<sub>MNB</sub>) represents a HNB's timing with respect to a macro cell (MNB) as measured by the UE where  $\Delta$ OTD<sub>cell</sub> is the timing of a UE with respect to a given cell [25]. The HNB-GW keeps a database of the  $\Delta$ OTD values for HNBs under its control and their neighbour MNB cells. The HNB-GW also keeps the mapping of a MNB's Cell ID and its PSC.

The HNB-GW updates the  $\Delta$ OTD database by using the information provided by the UEs during handovers to MNB cells. During these hand-outs, a HNB includes the MEASUREMENT REPORT message (MRM) in the RRC transparent container which is sent in the RANAP *Relocation Required* message and set the *Target Cell Id* IE to the ID of the macro cell with respect to which the OTD is computed.

### C.3.2 Target Cell Disambiguation for Handover to the HNB

The procedure can be implemented as follows:

1. UE is triggered to send an RRC Measurement Report (including OTD for both source and target cells) to the SRNC by the rules set by the UTRAN.
2. The source RAN triggers relocation of the UE session by sending the RANAP RELOCATION REQUIRED message to the Core Network:
  - The time difference information of the target HNB cell and the source Macro cell is contained in the *RRC Container* IE as defined in TS 25.331 [25].
  - Source Cell ID is transmitted in the *Source RNC to Target RNC Transparent Container*.
  - *Target Cell ID* IE may be set to a special value since the actual Cell ID is not known.
3. HNB-GW determines that PSC disambiguation is needed when target cell ID does not identify a HNB under its control. The HNB GW selects the target HNB using the received information (including the source Cell ID and MRM) and the  $\Delta$ OTD database.
4. The remainder of the relocation procedure continues normally as documented in 3GPP TS 25.413 [9] and 3GPP TS 23.060 [10].

Additionally, after the successful inbound handover, the HNB GW can update the  $\Delta$ OTD information between the target HNB cell and the source MNB cell using the received information.

## C.4 Notes

For both solutions described above, the following notes apply:

- NOTE 1: It is assumed that the HNB GW/RNC has the mapping of neighbouring cells PSCs and Cell IDs.
- NOTE 2: If OTD signatures are not maintained up to date, handover failures may occur.

NOTE 3: The range of  $\Delta$ OTDs will be different for intra and inter-frequency cell measurements (e.g., when the HNB cell is measured on another frequency than the source cell). Consequently the disambiguation performance in the two scenarios may differ.

## Annex D (informative): Change History

TSG #	TSG Doc.	CR	Rev	Subject/Comment	New
09/2009				Rel-9 version is created based on v.8.3.0	9.0.0
45	RP-090999	0044	3	Support for paging optimization with CSG membership changes	9.0.0
45	RP-090999	0048	1	Enhancements to handle HNB to HNB mobility	9.0.0
45	RP-090999	0049	1	Access Mode and Membership notification for UEs accessing CSG-Hybrid cells	9.0.0
10/2009				Editorial changes: 5.x.2 -> 5.7.2 and adding numbering to Figure 5.7.2-1	9.0.1
46	RP-091191	0039	4	CS Mux on Uplink	9.1.0
46	RP-091195	0053	2	Enhanced Interference Management Mechanisms for HNB	9.1.0
46	RP-091191	0057		Introducing changes for supporting ETWS in Home Node B (Rel9)	9.1.0
46	RP-091184	0059	1	Add assigned SCTP Port Number for RUA and HNBAP	
46	RP-091191	0061		Addition of use of COMMON ID message to convey Hybrid cell membership information.	9.1.0
46	RP-091184	0067		Clean up of 25.467	9.1.0
46	RP-091191	0070	1	Mitigating IMSI spoofing in non-CSG UE registration	9.1.0
46	RP-091191	0071	1	UE registration in case of HNB-GW access control	9.1.0
46	RP-091191	0072	1	Inbound Mobility to CSG and Hybrid Cells	9.1.0
47	RP-100219	0073		Clarification of HNB Definition	9.2.0
47	RP-100219	0075		Corrections on the non-CSG UEs registration and luh Disconnect Procedure	9.2.0
47	RP-100365	0076	3	Removal of incomplete material for intra-GW Handover	9.2.0
47	RP-100222	0083	2	Removal of FFS in Rel-9 stage 2 specification	9.2.0
47	RP-100222	0085	7	CSG expiry Handling	9.2.0
47	RP-100222	0086	2	PSC Split Clarification	9.2.0
47	RP-100222	0087	3	Clarifications on UE registration and mobility procedures	9.2.0
48	RP-100595	0092	2	Support of HNB GW functionalities	9.3.0
48	RP-100595	0094		Location information correction for Stage 2	9.3.0
50	RP-101271	0111		PPI value for SABP in luh	9.4.0
50	RP-101271	0113		Clarification on Inbound Mobility to HNB	9.4.0
12/2010				Rel-10 version is created based on version 9.4.0	10.0.0
50	RP-101407	0101	5	Introduction of the Implementation Variant where CN functions for the enhancement of inter-HNB intra-HNB-GW SRNS Relocation are implemented within the HNB-GW.	10.0.0
50	RP-101272	0112	2	Clarification of use of RNC-Id	10.0.0
50	RP-101188	0114	4	Introduction of HNB to HNB mobility procedure using direct interface	10.0.0
50	RP-101389	0117	2	Introduction of LIPA Functions for UMTS	10.0.0
SP-49	SP-100629			Clarification on the use of References (TS 21.801 CR#0030)	10.1.0
51	RP-110231	0125		Correction on UE De-Registration for Enhanced H2H Mobility	10.1.0
51	RP-110227	0126		Completion of LIPA feature	10.1.0
51	RP-110231	0131	2	Correction to definition of HNB enhanced mobility	10.1.0
52	RP-110689	0135		Removal of double-numbering from 3 sub-clauses	10.2.0
52	RP-110691	0136	2	Removal of Access Query Procedure for Intra-CSG Handover	10.2.0
52	RP-110686	0140	4	Cleanup and small corrections of 25.467 before Rel-10 closure	10.2.0
52	RP-110691	0142	2	Final specification of the provision of luh-connectivity related TNL addresses	10.2.0
53	RP-111194	0144	1	Corrections on Partial Failure During Enhanced H2H Mobility	10.3.0
53	RP-111196	0148	1	Access Control for Sof Handover between HNBs	10.3.0
53	RP-111194	0150	2	Stage 2 clean-up for HNB mobility	10.3.0
53	RP-111192	0153	1	Remaining UE Context Issue during Mobility	10.3.0
53	RP-111196	0155	1	Correction to protocol stack	10.3.0
53	RP-111194	0157	1	SHO for different luh Connectivity	10.3.0
53	RP-111194	0158	1	Security Mechanism for H(e)NB "no-IPsec" usage option	10.3.0
54	RP-111651	0159	1	Rapporteur update on specification references	10.4.0
54	RP-111648	0160	1	Access Control in RNSAP Relocation between HNBs	10.4.0
54	RP-111650	0161		Measurement configuration for Inbound Mobility	10.4.0
54	RP-111651	0162	2	Corrections on UE Registration Procedure	10.4.0
54	RP-111646	0164		Correction of Emergency Call	10.4.0
56	RP-120744	0173	3	Correction of emergency call handling during Inbound mobility	10.5.0

57	RP-121131	0177		Corrections on lurh Setup	10.6.0
09/2012				Rel-11 version is created based on version 10.6.0	
57	RP-121136	0178	2	Introduction of connectivity between HNBs and RNCs via the HNB-GW for RNSAP signalling	11.0.0
57	RP-121140	0179	2	Verification of HNB Identity	11.0.0
58	RP-121736	0184		Clarification of target HNB behaviour in case of Relocation Failure	11.1.0
58	RP-121732	0185	2	Introduction of connectivity between HNB and RNC via HNB-GW for RNSAP signalling: soft handover between HNB and RNC	11.1.0
58	RP-121732	0188	2	Introduction of connectivity between HNB and RNC via HNB-GW for RNSAP signaling: Enhanced Relocation between HNB and RNC	11.1.0
58	RP-121733	0189	1	Support or Legacy UEs hand-in	11.1.0
58	RP-121739	0190	2	New Information for BBF access	11.1.0
58	RP-121733	0193		Support of the Target HNB Cell Disambiguation at the HNB-GW	11.1.0
59	RP-130211	0195	2	Clarification on inter-PLMN HO to CSG cell	11.2.0
59	RP-130212	0197	1	Rapporteur editorial corrections	11.2.0
60	RP-130643	0199		Correction of the reference architecture figure	11.3.0
61	RP-131183	0204		Correction of HNB Verification	11.4.0
61	RP-131183	0205		Correction for the reference model	11.4.0