

3GPP TS 25.432 V11.0.0 (2012-09)

Technical Specification

3rd Generation Partnership Project; Technical Specification Group Radio Access Network; UTRAN Iub interface: signalling transport (Release 11)



The present document has been developed within the 3rd Generation Partnership Project (3GPP™) and may be further elaborated for the purposes of 3GPP. The present document has not been subject to any approval process by the 3GPP Organizational Partners and shall not be implemented. This Specification is provided for future development work within 3GPP only. The Organizational Partners accept no liability for any use of this Specification. Specifications and reports for implementation of the 3GPP™ system should be obtained via the 3GPP Organizational Partners' Publications Offices.

Keywords

UMTS, radio

3GPP

Postal address

3GPP support office address

650 Route des Lucioles - Sophia Antipolis
Valbonne - FRANCE
Tel.: +33 4 92 94 42 00 Fax: +33 4 93 65 47 16

Internet

<http://www.3gpp.org>

Copyright Notification

No part may be reproduced except as authorized by written permission.
The copyright and the foregoing restriction extend to reproduction in all media.

© 2012, 3GPP Organizational Partners (ARIB, ATIS, CCSA, ETSI, TTA, TTC).
All rights reserved.

UMTS™ is a Trade Mark of ETSI registered for the benefit of its members
3GPP™ is a Trade Mark of ETSI registered for the benefit of its Members and of the 3GPP Organizational Partners
LTE™ is a Trade Mark of ETSI currently being registered for the benefit of its Members and of the 3GPP Organizational Partners
GSM® and the GSM logo are registered and owned by the GSM Association

Contents

Foreword	4
1 Scope	5
2 References.....	5
3 Definitions, symbols and abbreviations	6
3.1 Definitions	6
3.2 Symbols.....	6
3.3 Abbreviations.....	6
4 Data Link Layer.....	6
4.1 ATM Transport Option.....	6
4.1.1 Protection switching at ATM Layer	6
4.2 Data Link Layer for IP Transport Option.....	6
5 NBAP signalling bearer.....	7
5.1 Introduction	7
5.2 Signalling bearer in case of ATM Transport Option.....	7
5.3 Signalling bearer in case of IP Transport Option.....	7
Annex A (informative): Change history.....	9

Foreword

This Technical Specification has been produced by the 3rd Generation Partnership Project (3GPP).

The contents of the present document are subject to continuing work within the TSG and may change following formal TSG approval. Should the TSG modify the contents of the present document, it will be re-released by the TSG with an identifying change of release date and an increase in version number as follows:

Version x.y.z

where:

- x the first digit:
 - 1 presented to TSG for information;
 - 2 presented to TSG for approval;
 - 3 or greater indicates TSG approved document under change control.
- y the second digit is incremented for all changes of substance, i.e. technical enhancements, corrections, updates, etc.
- z the third digit is incremented when editorial only changes have been incorporated in the document.

1 Scope

The present document specifies the signalling transport related to NBAP signalling to be used across the Iub Interface. The Iub interface is a logical interface for the interconnection of Node B and Radio Network Controller (RNC) components of the UMTS Terrestrial Radio Access Network (UTRAN) for the UMTS system. The radio network control signalling between these nodes is based on the Node B application part (NBAP).

2 References

The following documents contain provisions which, through reference in this text, constitute provisions of the present document.

- References are either specific (identified by date of publication, edition number, version number, etc.) or non-specific.
- For a specific reference, subsequent revisions do not apply.
- For a non-specific reference, the latest version applies. In the case of a reference to a 3GPP document (including a GSM document), a non-specific reference implicitly refers to the latest version of that document *in the same Release as the present document*.

- [1] ITU-T Recommendation Q.2100 (1994-07): "B-ISDN signalling ATM adaptation layer (SAAL) overview description".
- [2] ITU-T Recommendation Q.2130 (1994-07): "B-ISDN signalling ATM adaptation layer – Service specific coordination function for support of signalling at the user network interface (SSCF–UNI)".
- [3] ITU-T Recommendation Q.2110 (1994-07): "B-ISDN ATM adaptation layer – Service specific connection oriented protocol (SSCOP)".
- [4] ITU-T Recommendation I.363.5 (1996-08): "B-ISDN ATM Adaptation Layer Specification : Type 5 AAL".
- [5] ITU-T Recommendation I.361 (1995-11): "B-ISDN ATM layer specification".
- [6] ITU-T Recommendation I.630 (1999-02): "ATM protection switching".
- [7] IETF RFC 2960 (2000-10): "Stream Control Transmission Protocol".
- [8] IETF RFC 2460 (1998-12): "Internet Protocol, Version 6 (IPv6) Specification".
- [9] IETF RFC 791 (1981-09): "Internet Protocol".
- [10] IETF RFC 2474 (1998-12): "Definition of the Differentiated Services Field (DS Field) in the IPv4 and IPv6 Headers".
- [11] IETF RFC 1661 (1994-07): "The Point-to-Point Protocol (PPP)".
- [12] IETF RFC 1662 (1994-07): "PPP in HDLC-like Framing".
- [13] IETF RFC 2507 (1999-02): "IP header compression".
- [14] IETF RFC 1990 (1996-08): "The PPP Multilink Protocol (MP)".
- [15] IETF RFC 2686 (1999-09): "The Multi-Class Extension to Multi-Link PPP".
- [16] IETF RFC 2509 (1999-02): "IP Header Compression over PPP".
- [17] IETF RFC 3153 (2001-08): "PPP Multiplexing".
- [18] IETF RFC 2364 (1998-07): "PPP over AAL5".

- [19] IETF RFC 3031 (2001-01): "Multiprotocol Label Switching Architecture".
- [20] IETF RFC 3309 (2002-09): "Stream Control Transmission Protocol (SCTP) Checksum Change".
- [21] 3GPP TS 25.433: "UTRAN Iub interface Node B Application Part (NBAP) signalling".

3 Definitions, symbols and abbreviations

3.1 Definitions

For the purposes of the present document, the following terms and definitions apply:

IP UTRAN node: An UTRAN Node supporting the IP Transport Option

3.2 Symbols

(void)

3.3 Abbreviations

AAL	ATM Adaptation Layer
ATM	Asynchronous Transfer Mode
HDLC	High-level Data Link Control
IP	Internet Protocol
NBAP	Node B Application Part
PPP	Point-to-Point Protocol
RNC	Radio Network Controller
SAAL	Signalling ATM Adaptation Layer
SCTP	Stream Control Transmission Protocol
SSCF	Service Specific Coordination Function
SSCOP	Service Specific Connection Oriented Protocol
UNI	User-Network Interface

4 Data Link Layer

4.1 ATM Transport Option

ATM shall be used in the radio network control plane according to ITU-T Rec. I.361 [5].

4.1.1 Protection switching at ATM Layer

If redundancy of pathways at ATM layer between RNC and Node B is supported, it shall be implemented using ATM Protection Switching according to ITU-T Rec. I.630 [6].

4.2 Data Link Layer for IP Transport Option

A RNC or Node B supporting IP Transport Option shall support the PPP protocol with HDLC framing (IETF RFC 1661 [11], IETF RFC 1662 [12]).

NOTE: This does not preclude the single implementation and use of any other L2/L1 protocols (e.g. PPPMux/AAL5/ATM (IETF RFC 3153 [17], IETF RFC 2364 [18]), PPP/AAL2/ATM, Ethernet, MPLS/ATM (IETF RFC 3031 [19]), etc.) fulfilling the UTRAN requirements towards the upper layers.

A RNC or Node B supporting IP transport option and having interfaces connected via slow bandwidth PPP links like E1/T1/J1 shall also support IP Header Compression (IETF RFC 2507 [13]) and the PPP extensions ML/MC-PPP (IETF RFC 1990 [14], IETF RFC 2686 [15]). In this case, negotiation of header compression (IETF RFC 2507 [13]) over PPP shall be performed via (IETF RFC 2509 [16]).

5 NBAP signalling bearer

5.1 Introduction

The Signalling Bearer for NBAP (TS 25.433 [21]) is a point-to-point protocol. There may be multiple point-to-point links between an RNC and a Node B. As shown in figure 1, the standard allows operators to choose one out of two protocol suites for transporting the NBAP messages.

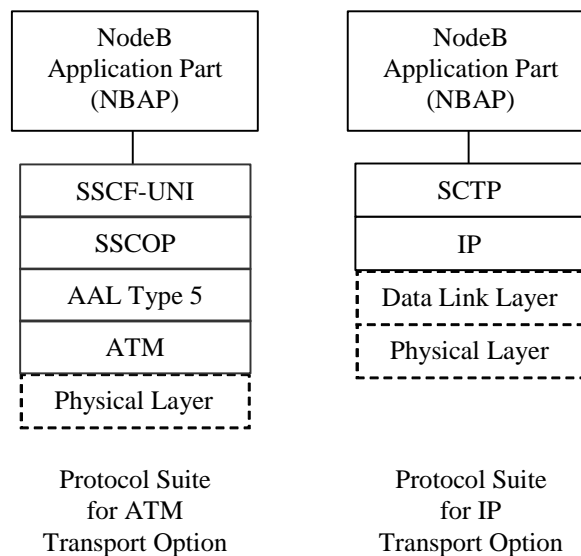

Figure 1: Iub NBAP Signalling Transport

5.2 Signalling bearer in case of ATM Transport Option

The signalling bearer in the Radio Network Control Plane is SAAL-UNI (ITU-T Rec. Q.2100 [1]) over ATM. The protocols to be used to support NBAP signalling are SSCF-UNI (ITU-T Rec. Q.2130 [2]) on top of SSCOP (ITU-T Rec. Q.2110 [3]) and AAL Type 5 (ITU-T Rec. I.363.5 [4]).

5.3 Signalling bearer in case of IP Transport Option

SCTP (IETF RFC 2960 [7]) over IP shall be supported as the transport for NBAP signalling bearer on Iub Interface. A RNC equipped with the SCTP stack option shall initiate the INIT procedure for establishing association. The data link layer is as specified in chapter 4.2.

The checksum method specified in IETF RFC 3309 [20] shall be used instead of the method specified in IETF RFC 2960 ([7]).

An IP UTRAN node shall support IPv6 (IETF RFC 2460 [8]). The support of IPv4 (IETF RFC 791 [9]) is optional.

NOTE: This does not preclude single implementation and use of IPv4.

IP dual stack is recommended for the potential transition period from IPv4 to IPv6 in the transport network.

Each signalling bearer between the RNC and Node B shall correspond to one single SCTP stream in UL and one single SCTP stream in DL direction, both streams belonging to the same SCTP association.

IP Differentiated Services code point marking (IETF RFC 2474 [10]) shall be supported. The Diffserv code point may be determined from the application parameters.

Annex A (informative): Change history

Date / TSG	TSG Doc.	CR	Rev	Subject/Comment	New
12/2008	-	-	-	Creation of Rel-8 version based on v7.1.0	8.0.0
12/2009	-	-	-	Creation of Rel-9 version based on v8.0.0	9.0.0
SP-49	SP-100629			Clarification on the use of References (TS 21.801 CR#0030)	9.0.1
03/2011				Creation of Rel-10 version based on v9.0.1	10.0.0
52	RP-110685	0008	1	Correction to the References	10.1.0
09/2012				Update to Rel-11 version (MCC)	11.0.0