

3GPP TS 25.410 V11.0.0 (2012-09)

Technical Specification

3rd Generation Partnership Project; Technical Specification Group Radio Access Network; UTRAN Iu Interface: general aspects and principles (Release 11)



The present document has been developed within the 3rd Generation Partnership Project (3GPPTM) and may be further elaborated for the purposes of 3GPP. The present document has not been subject to any approval process by the 3GPP Organisational Partners and shall not be implemented. This Specification is provided for future development work within 3GPP only. The Organisational Partners accept no liability for any use of this Specification. Specifications and reports for implementation of the 3GPPTM system should be obtained via the 3GPP Organisational Partners' Publications Offices.

Keywords

UTRAN, radio

3GPP

Postal address

3GPP support office address

650 Route des Lucioles - Sophia Antipolis
Valbonne - FRANCE
Tel.: +33 4 92 94 42 00 Fax: +33 4 93 65 47 16

Internet

<http://www.3gpp.org>

Copyright Notification

No part may be reproduced except as authorized by written permission.
The copyright and the foregoing restriction extend to reproduction in all media.

© 2012, 3GPP Organizational Partners (ARIB, ATIS, CCSA, ETSI, TTA, TTC).
All rights reserved.

UMTS™ is a Trade Mark of ETSI registered for the benefit of its members
3GPP™ is a Trade Mark of ETSI registered for the benefit of its Members and of the 3GPP Organizational Partners
LTE™ is a Trade Mark of ETSI currently being registered for the benefit of its Members and of the 3GPP Organizational Partners
GSM® and the GSM logo are registered and owned by the GSM Association

Contents

Foreword	5
1 Scope	6
2 References.....	6
3 Definitions and abbreviations	7
3.1 Definitions	7
3.2 Abbreviations.....	7
3.3 Specification Notations	8
4 General Aspects.....	9
4.1 UTRAN Architecture.....	9
4.1.1 I _u Interface Architecture	9
4.1.2 I _u connection principles.....	10
4.1.3 Implementation of the NAS Node Selection Function	10
4.1.4 Implementation of MOCN configuration support.....	10
4.2 I _u Interface General Principles	10
4.3 I _u Interface Specification Objectives	10
4.4 I _u Interface Capabilities	11
4.5 I _u Interface Characteristics	11
4.5.1 Use of Transport Network User Plane as Signalling Bearer	11
4.5.1.1 Use of SCCP	11
4.5.1.1.1 General.....	11
4.5.1.1.2 SCCP Connection Establishment procedure	12
4.5.1.1.3 SCCP Connection Release procedure	14
4.5.1.1.4 General SCCP Abnormal Conditions	14
4.5.1.2 Use of MTP3b	15
4.5.2 Use of Transport Network User Plane as User Data Bearer	15
4.5.2.1 Use of AAL2	15
4.5.2.2 Use of GTP-U.....	15
4.5.2.3 Use of RTP.....	15
4.5.3 Use of Transport Network User Plane on Iu-BC.....	15
5 Functions of the I _u Interface Protocols & Functional Split	16
5.1 General	16
5.2 RAB management Functions.....	18
5.2.1 RAB establishment, modification and release function	18
5.2.2 RAB characteristics mapping to Uu bearers function	18
5.2.3 RAB characteristics mapping to Iu transport bearers	18
5.2.4 RAB queuing, pre-emption and priority function.....	18
5.3 Radio Resource Management over Iu.....	18
5.3.1 Radio resource admission control	18
5.3.2 Broadcast information management	19
5.4 I _u link Management functions	19
5.4.1 I _u Signalling Link Management function	19
5.4.2 ATM Virtual Connection Management function.....	19
5.4.3 AAL2 connection establish and release function	19
5.4.4 AAL5 management function	19
5.4.5 GTP-U tunnels management function	19
5.4.6 TCP Management Function.....	19
5.4.7 Buffer Management	20
5.4.8 RTP Session Management Function.....	20
5.5 I _u U-plane (RNL) Management Functions	20
5.5.1 I _u U-plane frame protocol mode selection function	20
5.5.2 I _u U-plane frame protocol initialisation	20
5.6 Mobility Management Functions	20
5.6.1 Location information update function	20
5.6.2 Handover and Relocation functions.....	20

5.6.2.1	Inter RNC hard HO function, Iur not used or not available	20
5.6.2.2	Serving RNS Relocation function.....	21
5.6.2.3	Inter system Handover (e.g. UMTS-GSM) function	21
5.6.2A	Inter System Change (e.g. UMTS-GSM) function.....	21
5.6.3	Paging Triggering.....	21
5.6.4	Shared Networks Access Control.....	21
5.6.5	GERAN System Information Retrieval.....	21
5.7	Security Functions.....	21
5.7.1	Data Confidentiality.....	21
5.7.1.1	Radio interface ciphering function.....	21
5.7.1.2	Ciphering key management function.....	21
5.7.2	Data integrity	22
5.7.2.1	Integrity checking	22
5.7.2.2	Integrity key management.....	22
5.8	Service and Network Access Functions	22
5.8.1	Core Network signalling data transfer function.....	22
5.8.2	Data Volume Reporting	22
5.8.3	UE Tracing	22
5.8.4	Location reporting function	22
5.8.5	MDT	22
5.9	Co-ordination Functions.....	22
5.9.1	Paging Co-ordination function.....	22
5.9.2	NAS Node Selection Function.....	22
5.9.3	Information Transfer Function.....	23
5.9.4	MOCN Rerouting Function.....	23
5.9.5	SIPTO at Iu-PS Function	23
5.10	MBMS Functions	23
5.10.1	MBMS RAB Management functions	23
5.10.2	MBMS UE Linking Function.....	23
5.10.3	MBMS Registration Control Function	23
5.10.4	MBMS Enquiry Function	23
6	I _u Interface Protocol Structure	24
6.1	General	24
6.2	I _u -CS.....	25
6.3	I _u -BC.....	26
6.4	I _u -PS	27
7	Other I _u Interface Specifications.....	27
7.1	UTRAN I _u Interface: Layer 1 (3GPP TS 25.411)	27
7.2	UTRAN I _u Interface: Signalling Transport (3GPP TS 25.412)	27
7.3	UTRAN I _u Interface: RANAP Specification (3GPP TS 25.413)	27
7.4	UTRAN I _u Interface: Data Transport and Transport Signalling (3GPP TS 25.414)	28
7.5	UTRAN I _u Interface: CN-UTRAN User Plane Protocol (3GPP TS 25.415)	28
7.6	UTRAN I _u Interface: Service Area Broadcast Protocol SABP (3GPP TS 25.419)	28
7.7	Summary	28
Annex A (informative):	Change History.....	29

Foreword

This Technical Specification (TS) has been produced by the 3rd Generation Partnership Project (3GPP).

The contents of the present document are subject to continuing work within the TSG and may change following formal TSG approval. Should the TSG modify the contents of the present document, it will be re-released by the TSG with an identifying change of release date and an increase in version number as follows:

Version x.y.z

where:

- x the first digit:
 - 1 presented to TSG for information;
 - 2 presented to TSG for approval;
 - 3 or greater indicates TSG approved document under change control.
- y the second digit is incremented for all changes of substance, i.e. technical enhancements, corrections, updates, etc.
- z the third digit is incremented when editorial only changes have been incorporated in the document.

1 Scope

The present document is an introduction to the 3GPP TS 25.41x series of Technical Specifications that define the Iu interface for the interconnection of Radio Network Controller (RNC) component of the UMTS Terrestrial Radio Access Network (UTRAN) to the Core Network of the UMTS system.

2 References

The following documents contain provisions which, through reference in this text, constitute provisions of the present document.

- References are either specific (identified by date of publication, edition number, version number, etc.) or non-specific.
- For a specific reference, subsequent revisions do not apply.
- For a non-specific reference, the latest version applies. In the case of a reference to a 3GPP document (including a GSM document), a non-specific reference implicitly refers to the latest version of that document *in the same Release as the present document*.

- [1] 3GPP TS 25.401: "UTRAN Overall Description".
- [2] 3GPP TR 23.930: "Iu Principles".
- [3] 3GPP TS 23.110: "UMTS Access Stratum Services and Functions".
- [4] 3GPP TS 25.411: "UTRAN Iu Interface Layer 1".
- [5] 3GPP TS 25.412: "UTRAN Iu Interface Signalling Transport".
- [6] 3GPP TS 25.413: "UTRAN Iu Interface RANAP Signalling".
- [7] 3GPP TS 25.414: "UTRAN Iu Interface Data Transport and Transport Signalling".
- [8] 3GPP TS 25.415: "UTRAN Iu Interface User Plane Protocols".
- [9] ITU-T Recommendation Q.711 (1996-07): "Functional description of the signalling connection control part".
- [10] ITU-T Recommendation Q.712 (1996-07): "Definition and function of signalling connection control part messages".
- [11] ITU-T Recommendation Q.713 (1996-07): "Signalling connection control part formats and codes".
- [12] ITU-T Recommendation Q.714 (1996-07): "Signalling connection control part procedures".
- [13] 3GPP TS 23.003: "Numbering, Addressing and Identification".
- [14] 3GPP TS 25.419: "UTRAN Iu Interface: Service Area Broadcast Protocol SABP".
- [15] 3GPP TS 23.153: "Out of Band Transcoder Control; Stage 2".
- [16] ITU-T Recommendation Q.2630.1: "AAL type 2 signalling protocol - (Capability Set 1)".
- [17] ITU-T Recommendation Q.2630.2: "AAL type 2 signalling protocol - Capability Set 2".
- [18] IETF RFC 3332 (2002-09): "Signalling System 7 (SS7) Message Transfer Part 3 (MTP3) – User Adaptation Layer (M3UA)".
- [19] IETF RFC 1889 (1996-01): "RTP: A Transport Protocol for Real Time Applications".
- [20] IETF RFC 768 (1980-08): "User Datagram Protocol".

- [21] IETF RFC 793 (1981-09): "TCP, Transmission Control Protocol".
- [22] IETF RFC 791 (1981-09): "Internet Protocol".
- [23] Void
- [24] Void
- [25] 3GPP TS 23.236: "Intra-domain connection of Radio Access Network (RAN) nodes to multiple Core Network (CN) nodes".
- [26] 3GPP TS 23.251: "Network sharing; Architecture and functional description".
- [27] 3GPP TS 23.246: Multimedia Broadcast/Multicast Service (MBMS) Architecture and functional description
- [28] 3GPP TS 25.346: "Introduction of the Multimedia Broadcast Multicast Service (MBMS) in the Radio Access Network (RAN); Stage 2".
- [29] 3GPP TS 23.060: "General Packet Radio Service (GPRS); Service description; Stage 2".
- [30] 3GPP TS 37.320: "Universal Terrestrial Radio Access (UTRA) and Evolved Universal Terrestrial Radio Access (E-UTRA); Radio measurement collection for Minimization of Drive Tests (MDT); Overall description; Stage 2".

3 Definitions and abbreviations

3.1 Definitions

For the purposes of the present document, the terms and definitions given in TS 25.401 [1] apply.

MBMS related terms and definitions:

MBMS bearer service: as defined in TS 23.246 [27].

MBMS RAB: as defined in TS 25.346 [28].

MBMS in signalling connection: as defined in TS 25.346 [28].

MBMS session start: as defined in TS 25.346 [28].

3.2 Abbreviations

For the purposes of the present document, the following abbreviations apply:

3G-MSC	3 rd Generation Mobile Switching Centre
3G-SGSN	3 rd Generation Serving GPRS Support Node
AAL	ATM Adaptation Layer
ATM	Asynchronous Transfer Mode
BC	Broadcast
BSSMAP	Base Station Subsystem Management Application Part
CBS	Cell Broadcast Service
CC	Connection Confirm
CN	Core Network
CR	Connection Release
CREF	Connection Refusal
CS	Circuit Switched
GT	Global Title
GTP-U	GPRS Tunnelling Protocol
GW CN	Gateway Core Network
IMSI	International Mobile Subscriber Identity
IP	Internet Protocol

ISDN	Integrated Services Digital Network
LA	Location Area
M3UA	MTP3 User Adaptation Layer
MBMS	Multimedia Broadcast Multicast Service
MDT	Minimization of Drive-Tests
MOCN	Multi Operator Core Network
NAS	Non Access Stratum
NACC	Network Assisted Cell Change
NNSF	NAS Node Selection Function
O&M	Operation and Maintenance
PLMN	Public Land Mobile Network
PS	Packet Switched
PSTN	Public Switched Telephone Network
PVC	Permanent Virtual Circuit
QoS	Quality of Service
RA	Routing Area
RAB	Radio Access Bearer
RANAP	Radio Access Network Application Part
RIM	RAN Information Management
RLP	Radio Link Protocol
RNC	Radio Network Controller
RNL	Radio Network Layer
RRC	Radio Resource Control
RTCP	Real Time Control Protocol
RTP	Real Time Protocol
SA	Service Area
SABP	Service Area Broadcast Protocol
SAP	Service Access Point
SCCP	Signalling Connection Control Part
SIPTO	Selected IP Traffic Offload
SCTP	Stream Control Transmission Protocol
SNA	Shared Network Area
SPC	Signalling Point Code
SRNS	Serving Radio Network Subsystem
SSN	Sub-System Number
SVC	Switched Virtual Circuit
TCP	Transmission Control Protocol
UE	User Equipment
UDP	User Datagram Protocol
UP	User Plane
URA	UTRAN Registration Area
UTRAN	UMTS Terrestrial Radio Access Network
VC	Virtual Circuit

3.3 Specification Notations

For the purposes of the present document, the following notations apply:

Procedure	When referring to a procedure in the specification the Procedure Name is written with the first letters in each word in upper case characters followed by the word "procedure", e.g. Radio Network Layer procedures.
Message	When referring to a message in the specification the MESSAGE NAME is written with all letters in upper case characters followed by the word "message", e.g. RADIO LINK SETUP REQUEST message.
Frame	When referring to a control or data frame in the specification the CONTROL/DATA FRAME NAME is written with all letters in upper case characters followed by the words "control/data frame", e.g. DCH transport frame.

4 General Aspects

4.1 UTRAN Architecture

4.1.1 Iu Interface Architecture

The overall UMTS architecture and UTRAN architectures are described in TS 25.401 [1]. This subclause specifies only the architecture of the Iu interface, and shall not constrain the network architecture of either Core or Radio Access Networks.

The Iu interface is specified at the boundary between the Core Network and UTRAN. Figure 4.1 depicts the logical division of the Iu interface. From the Iu perspective, the UTRAN access point is an RNC.

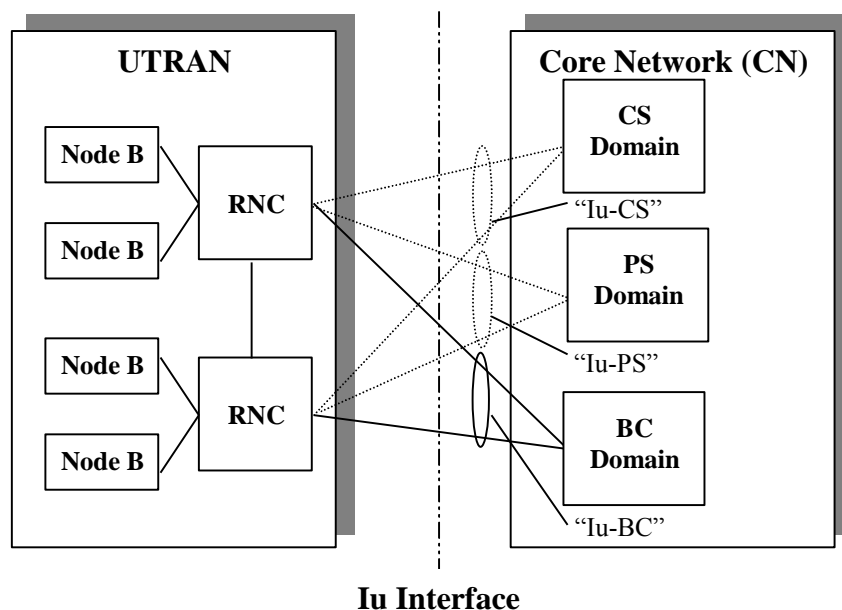

Figure 4.1: Iu Interface Architecture

The Iu interface towards the PS-domain of the core network is called Iu-PS, and the Iu interface towards the CS-domain is called Iu-CS. The differences between Iu-CS and Iu-PS are treated elsewhere in the present document. The Iu interface to the Broadcast domain is called Iu-BC.

There shall not be more than one Iu interface (Iu-PS) towards the PS-domain from any one RNC – except where the NNSF is used, see subclause 4.1.3, or in MOCN configuration – see TS 23.251 [26]. Each RNC shall not have more than one Iu interface (Iu-CS) towards its default CN node within the CS domain, but may also have further Iu interfaces (Iu-CS) towards other CN nodes within the CS domain. (See [6] for definition of Default CN node.) These further Iu interfaces (Iu-CS) shall only be used as a result of intra-MSC inter-system handover or SRNS relocation, in the case the anchor CN node directly connects to the target RNC. There may also be more than one Iu interface towards the CS-Domain if the NNSF is used – see subclause 4.1.3, or in MOCN configuration – see TS 23.251 [26]. There shall not be more than one Iu interface (Iu-BC) from an RNC towards the Broadcast domain.

In the separated core network architecture, this means that there shall be separate signalling and user data connections towards the PS and CS domains – this applies in both transport and radio network layers.

In the combined architecture, there shall be separate connections in the user plane towards the PS and CS domains (in both transport and radio network layers). In the control plane, there shall be separate SCCP connections to the two logical domains.

In either architecture, there can be several RNCs within UTRAN and so UTRAN may have several Iu access points towards the Core Network. As a minimum, each Iu access point (in UTRAN or CN) shall independently fulfil the requirements of the relevant Iu specifications (25.41x series – see clause 7).

4.1.2 I_u connection principles

The I_u interface has a hierarchical architecture where one higher layer entity controls several lower layer entities. The hierarchy for the CN - UTRAN signalling connection end points is described below:

- Each CN Access Point may be connected to one or more UTRAN Access Points.
- For the PS domain, each UTRAN Access Point shall not be connected to more than one CN Access Point – except where the NNSF is used, see subclause 4.1.3, or when RNC is shared in MOCN configuration..
- For the CS domain, each UTRAN Access Point may be connected to one or more CN Access Points.
- For the BC domain, each UTRAN Access Point may be connected to one CN Access Point only.

4.1.3 Implementation of the NAS Node Selection Function

The optional NAS Node Selection Function (NNSF) is described in TS 23.236 [25].

If the NAS Node Selection Function is used by an RNC:

- There may be more than one I_u interface (I_u-CS) towards the CS domain and/or more than one I_u interface (I_u-PS) towards the PS-domain from this RNC.

4.1.4 Implementation of MOCN configuration support

The MOCN configuration is described in TS 23.251 [26]. When the RNC is shared in MOCN configuration:

- There may be more than one I_u interface (I_u-CS) towards the CS domain of different CN operators and/or more than one I_u interface (I_u-PS) towards the PS-domain of different CN operators from this RNC.
- The MOCN Rerouting Function shall be supported.

4.2 I_u Interface General Principles

From a UTRAN perspective, maximising the commonality of the various protocols that flow on the I_u interface is desirable. This means at the minimum that:

- A common set of radio access bearer services will be offered by UTRAN to the Core Network nodes, regardless of their type (e.g. 3G-MSC or 3G-SGSN).

There will be a common functional split between UTRAN and the Core Network nodes, regardless of their type (e.g. 3G-MSC or 3G-SGSN).

Signalling in the radio network control plane shall not depend on the specific choice of transport layers.

4.3 I_u Interface Specification Objectives

The following objectives are partly derived from TR 23.930 [2].

The I_u interface shall be specified such that it can support:

- the interconnection of RNCs with Core Network Access Points within a single PLMN, and within several PLMNs in case of network sharing, as described in TS 23.251 [26].
- the interconnection of RNCs with Core Network Access Points irrespective of the manufacturer of any of the elements.
- all UMTS services.

The I_u interface shall facilitate the use of the same RNC, MSC or SGSN in all PLMNs.

The I_u interface shall facilitate the sharing of transport technology between I_u-PS and I_u-BC.

The I_u interface shall allow interworking to the GSM Core Network.

Independence between the protocol layers and between control and user planes shall be maintained on the I_u interface.

The I_u interface shall allow independent evolution of technologies within the Core, Radio Access and Transport Networks.

The I_u interface shall allow separate evolution of O&M facilities.

The I_u interface shall be standardised as an open and multi-vendor interface.

The I_u interface specifications shall facilitate the migration of some services from the CS-domain to the PS-domain. In particular, the RANAP protocol shall be common to both PS and CS domains, and the I_u user plane protocol(s) shall be independent of the core network domain (PS or CS), except where a specific feature is only required for one domain.

4.4 I_u Interface Capabilities

The following capabilities are derived from the requirements described in TR 23.930 [2].

The I_u interface supports:

- procedures to establish, maintain and release Radio Access Bearers;
- procedures to perform SRNS relocation, intra-system handover, inter-system handover and inter-system change;
- procedures to support the Cell Broadcast service;
- a set of general procedures, not related to a specific UE;
- the separation of each UE on the protocol level for user specific signalling management;
- the transfer of NAS signalling messages between UE and CN;
- location services by transferring requests from the CN to UTRAN, and location information from UTRAN to CN. The location information may comprise a geographical area identifier or global co-ordinates with uncertainty parameters;
- simultaneous access to multiple CN domains for a single UE;
- mechanisms for resource reservation for packet data streams;
- procedures to support MBMS bearer services;
- mechanisms to support SIPTO at I_u-PS for a specific UE (optional).

4.5 I_u Interface Characteristics

4.5.1 Use of Transport Network User Plane as Signalling Bearer

4.5.1.1 Use of SCCP

4.5.1.1.1 General

The SCCP (ITU-T Rec. Q.711 [9]/ITU-T Rec. Q.712 [10]/ITU-T Rec. Q.713 [11]/ITU-T Rec. Q.714 [12]) is used to support signalling messages between the CNs and the RNC. One user function of the SCCP, called Radio Access Network Application Part (RANAP), is defined. The RANAP uses one SCCP signalling connection per active UE and CN for the transfer of layer 3 messages. RANAP also uses one SCCP signalling connection per MBMS bearer service.

Both connectionless and connection-oriented procedures are used to support the RANAP. TS 25.413 [6] explains whether connection oriented or connectionless services should be used for each layer 3 procedure.

RANAP may use SSN, SPC and/or GT and any combination of them as addressing schemes for the SCCP. Which of the available addressing scheme to use for the SCCP is an operator matter.

When GT addressing is utilised, the following settings shall be used:

- SSN Indicator = 1 (RANAP SSN as defined in TS 23.003 [13] shall always be included).
- Global Title Indicator = 0100 (GT includes translation type, numbering plan, encoding scheme and nature of address indicator).
- Translation Type = 0000 0000 (not used).
- Numbering Plan = 0001 (E.163/4).
- Nature of Address Indicator = 000 0100 (International Significant Number).
- Encoding Scheme = 0001 or 0010 (BCD, odd or even).
- Routing indicator = 0 or 1 (route on GT or PC/SSN).

When used, the GT shall be the E.164 address of the relevant node.

The following subclauses describe the use of SCCP connections for RANAP transactions. Subclause 4.5.1.2 describes the connection establishment procedures. Subclause 4.5.1.3 describes the connection release procedures. Subclause 4.5.1.4 describes abnormal conditions.

4.5.1.1.2 SCCP Connection Establishment procedure

A new SCCP connection is established when information related to the communication between a UE and the network has to be exchanged between RNC and CN, and no SCCP connection exists between the CN and the RNC involved, for the concerned UE. A new SCCP connection is also established for MBMS service purpose between the RNC and CN.

Various SCCP connection establishment cases have to be distinguished:

- i) RNC Initiated SCCP Signalling Connection for a UE;
- ii) CN Initiated SCCP Signalling Connection for a UE;
- iii) CN Initiated SCCP Signalling Connection for an MBMS Service.

The above cases are the only cases currently identified for SCCP connection establishment. Others may emerge in the future.

4.5.1.1.2.1 Establishment procedure in case i

The SCCP signalling connection establishment is initiated, by the RNC, at the reception of the first layer 3 non access stratum message from the UE and at the execution of the enhanced relocation.

Initiation

The RNC sends SCCP CONNECTION REQUEST message to the Core Network. A RANAP message shall be included in the user data field of the SCCP CONNECTION REQUEST message when the RANAP message size is less than or equal to the maximum size of the user data field in the SCCP CONNECTION REQUEST message. When the RANAP message is longer than the maximum size, the user data field shall not be included in the SCCP CONNECTION REQUEST message.

If the Core Network receives an SCCP CONNECTION REQUEST message for a UE for which an SCCP connection already exists, or if the Core Network receives an SCCP CONNECTION REQUEST message that does not include a user data field, and later finds out that the SCCP CONNECTION REQUEST message was for a UE for which an SCCP connection already exists, the Core Network shall ensure that the new SCCP connection and the already existing SCCP connection are for the same UE, e.g. by security functions, and if so, release the already existing SCCP connection via the normal Iu Release procedure and all UTRAN resources allocated to it.

Termination

- **successful outcome**

- The SCCP CONNECTION CONFIRM message, which may optionally contain a connection oriented RANAP message in the user data field, is returned to the RNC.
- **unsuccessful outcome**
 - If the SCCP signalling connection establishment fails, an SCCP CONNECTION REFUSAL message will be sent back to the RNC. This message may contain a RANAP message in the user data field.

For more information on how the RANAP procedures Initial UE Message and Enhanced Relocation Complete are handled, please see the elementary procedures Initial UE Message and Enhanced Relocation Complete in TS 25.413 [6].

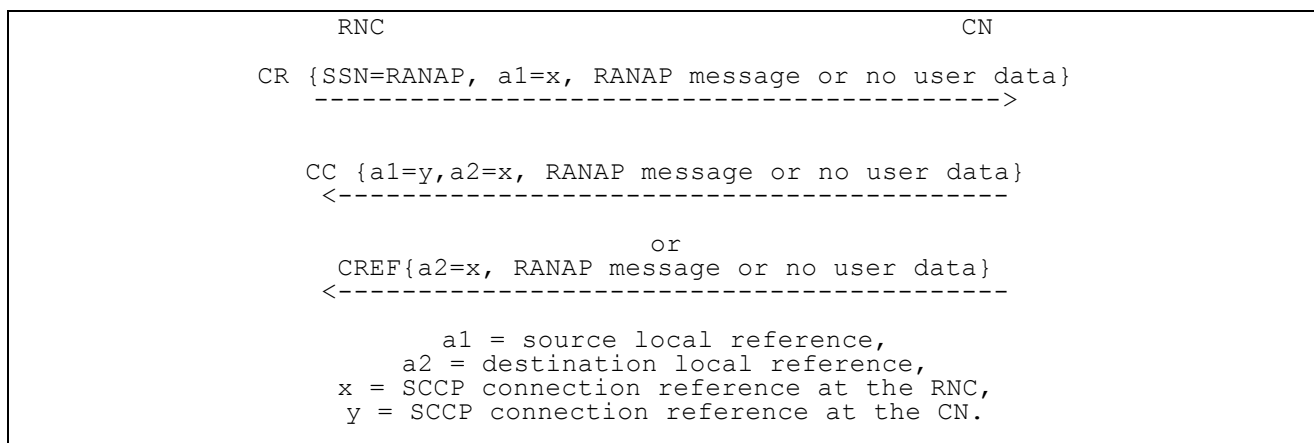

Figure 4.2: Setting-up of RNC Initiated SCCP Signalling Connection

4.5.1.1.2.2 Establishment procedure in case ii

The SCCP signalling connection establishment is initiated, by the Core Network, in connection with performing a Relocation.

Initiation

The Core Network initiates the connection establishment by sending an SCCP CONNECTION REQUEST message to the RNC. Optionally, a RANAP message may be included in the user data field of the SCCP CONNECTION REQUEST message.

Termination

- **successful outcome**
 - The SCCP CONNECTION CONFIRM message, which may optionally contain a connection oriented RANAP message in the user data field, is returned to the Core Network.
- **unsuccessful outcome**
 - If the SCCP signalling connection establishment fails, an SCCP CONNECTION REFUSAL message will be sent back to the Core Network. This message may contain a RANAP message in the user data field.

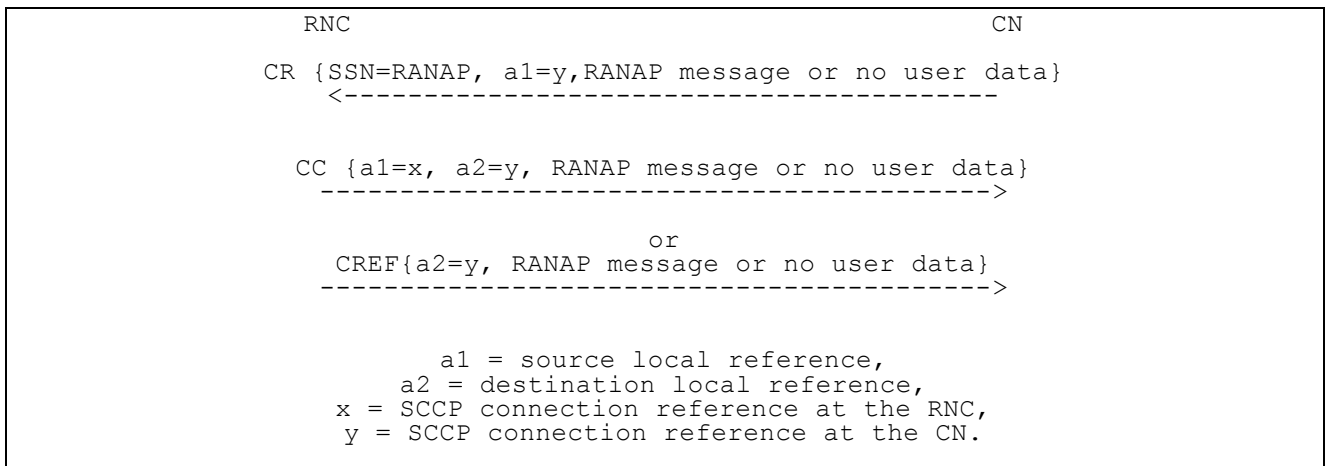

Figure 4.3: Setting-up of CN Initiated SCCP Signalling Connection

4.5.1.1.2.3 Establishment procedure in case iii

The SCCP signalling connection establishment is initiated, by the Core Network, to establish a new SCCP connection between the RNC and the CN for an MBMS service at the start of an MBMS session and when no SCCP connection already exists between the CN and the RNC involved, for the concerned MBMS service.

Initiation

The Core Network initiates the connection establishment by sending an SCCP CONNECTION REQUEST message to the RNC. Optionally, a RANAP message may be included in the user data field of the SCCP CONNECTION REQUEST message.

Termination

- **successful outcome**
 - The SCCP CONNECTION CONFIRM message, which may optionally contain a connection oriented RANAP message in the user data field, is returned to the Core Network.
- **unsuccessful outcome**
 - If the SCCP signalling connection establishment fails, an SCCP CONNECTION REFUSAL message will be sent back to the Core Network. This message may contain a RANAP message in the user data field.

4.5.1.1.3 SCCP Connection Release procedure

This procedure is always initiated at the Core Network side in normal release case.

An SCCP connection is released when the CN realises that a given signalling connection is no longer required.

The CN sends a SCCP RELEASED message.

The procedure may be initiated at the Core Network side and the RNC side in any abnormal release case.

4.5.1.1.4 General SCCP Abnormal Conditions

If a user-out-of-service information or signalling-point-inaccessible information is received by the RANAP, no new attempt to establish SCCP connections towards the affected point code will be started until the corresponding user-in-service information or signalling-point-accessible information is received.

When a user-out-of-service information or signalling-point-inaccessible is received by the RNC, an optional timer may be started. When the timer expires, all the SCCP connections towards the affected point code will be released. When the user-in-service or signalling-point-accessible is received, the timer is stopped.

If for any reason an SCCP connection is released, the optional timer expires or a connection refusal is received while any of the RANAP procedures are being performed or while a dedicated resource is still allocated, the following actions are taken:

At RNC:

- Any RNC procedure relating to that connection is abandoned.
- The UTRAN resources allocated to the connection are released.

At Core Network:

- The resources associated with the SCCP connection are cleared as soon as possible.

4.5.1.2 Use of MTP3b

- For a given MSC, the RNC shall be able to access RANAP and ALCAP either under the same MTP3b (IETF RFC 3332 [18]) destination point code, or under different point codes;
- For a given RNC, the MSC shall be able to access RANAP and ALCAP either under the same MTP3b destination point code, or under different point codes.

4.5.2 Use of Transport Network User Plane as User Data Bearer

4.5.2.1 Use of AAL2

In the ATM transport option AAL2 is used as the user data bearer towards the CS domain.

Q.2630.2 is used as the protocol for dynamically setup AAL-2 connections over Iu towards the CS domain. Q.2630.2 adds new optional capabilities to Q.2630.1.

4.5.2.2 Use of GTP-U

GTP-U is used as the user data bearer towards the PS domain.

RANAP Signalling is used to establish, modify and release the GTP-U tunnels towards the PS domain.

4.5.2.3 Use of RTP

RTP/UDP/IP (IETF RFC 1889 [19]/ IETF RFC 768 [20]/ IETF RFC 791 [22]) is used as the user data bearer towards the CS domain in the IP transport option. The use of RTCP (IETF RFC 1889 [19]) is optional.

RANAP Signalling is used to establish, modify and release RTP sessions towards the CS domain.

4.5.3 Use of Transport Network User Plane on Iu-BC

TCP/IP (IETF RFC 793 [21]/ IETF RFC 791 [22]) is used as the bearer for the radio network layer protocol over I_u-BC.

The TCP connection is normally established by the CN using standard TCP procedures.

A new TCP connection is established by the RNC only when there is information (e.g. failure or restart indications) that needs to be sent from RNC to the CN, and there is no existing TCP connection. The RNC shall establish the connection using standard TCP procedures.

The node that established the connection shall release the TCP connection.

5 Functions of the I_u Interface Protocols & Functional Split

5.1 General

This subclause defines the functional split between the core network and the UMTS radio access network. In addition, the possible interaction between the functions is defined. The functional split is shown in table 5.1.

Table 5.1: Iu interface functional split

Function	UTRAN	CN
RAB management functions:		
RAB establishment, modification and release	X	X
RAB characteristics mapping I _u transmission bearers	X	
RAB characteristics mapping Uu bearers	X	
RAB queuing, pre-emption and priority	X	X
Radio Resource Management functions:		
Radio Resource admission control	X	
Broadcast Information	X	X
I_u link Management functions:		
I _u signalling link management	X	X
ATM VC management	X	X
AAL2 establish and release	X	X
AAL5 management	X	X
GTP-U Tunnels management	X	X
TCP Management	X	X
Buffer Management	X	
I_u U-plane (RNL) Management:		
I _u U-plane frame protocol management		X
I _u U-plane frame protocol initialization	X	
Mobility management functions:		
Location information reporting	X	X
Handover and Relocation		
Inter RNC hard HO, Iur not used or not available	X	X
Serving RNS Relocation (intra/inter MSC)	X	X
Inter system hard HO (UMTS-GSM)	X	X
Inter system Change (UMTS-GSM)	X	X
Paging Triggering		X
GERAN System Information Retrieval	X	X
Security Functions:		
Data confidentiality		
Radio interface ciphering	X	
Ciphering key management		X
User identity confidentiality	X	X
Data integrity		
Integrity checking	X	
Integrity key management		X
Service and Network Access functions:		
CN Signalling data	X	X
Data Volume Reporting	X	
UE Tracing	X	X
MDT	X	X
Location reporting	X	X
I_u Co-ordination functions:		
Paging co-ordination	X	X
NAS Node Selection Function	X	
MOCN Rerouting Function	X	X
SIPTO at Iu-PS	X	X
MBMS functions		
MBMS RAB Management	X	X
MBMS UE Linking Function	X	X
MBMS Registration Control Function	X	X
MBMS Enquiry Function	X	X

5.2 RAB management Functions

5.2.1 RAB establishment, modification and release function

The RAB, Radio Access Bearer, is defined to be set-up between UE and CN. Depending on subscription, service, requested QoS etc. different types of RABs will be used. It is the CN that controls towards the UTRAN the establishment, modification or release of a RAB. Furthermore, the CN selects the type of the transport bearer, i.e. ATM or IP.

The RAB identity is allocated by CN by mapping the value for the NAS Binding information (from the actual protocol IE for the respective CN domain) to the RAB ID as specified in TS 23.110 [3]. The RAB identity is globally significant on both the radio bearer and on the Iu bearer for a given UE in a particular CN domain.

RAB establishment, modification and release is a CN initiated function.

RAB establishment, modification and release is a UTRAN executed function.

RAB release request is a UTRAN initiated function, triggered when UTRAN e.g. fails to keep the RAB established with the UE.

5.2.2 RAB characteristics mapping to Uu bearers function

The RAB characteristics mapping function is used to map the radio access bearers to the Uu bearers. The mapping is performed during the establishment of the RAB. UTRAN shall perform the mapping between the bearers.

RAB mapping to Uu transmission bearers is a UTRAN function.

5.2.3 RAB characteristics mapping to Iu transport bearers

The RAB characteristics mapping function is used to map the radio access bearers to the Iu interface transport bearers. The mapping is performed during the establishment of the RAB.

UTRAN shall perform this mapping between the bearers if AAL2 is used, since it is the UTRAN that establishes the AAL2 connections.

In case of RAB towards the PS domain, UTRAN shall perform the mapping between the radio access bearers and the IP layer.

RAB characteristics mapping to Iu transport bearers is a UTRAN function.

5.2.4 RAB queuing, pre-emption and priority function

The allocation/retention priority level of a RAB is determined by the CN based on e.g. subscription information, QoS information etc. Accordingly, the CN shall request RAB establishment or modification with an indication of the priority level and the pre-emption capability of that RAB and the queuing vulnerability. Queuing and resource pre-emption shall be performed by UTRAN accordingly.

RAB queuing, pre-emption and allocation/retention priority handling is a UTRAN controlled function.

RAB queuing, pre-emption and allocation/retention priority setting is a CN function.

5.3 Radio Resource Management over Iu

5.3.1 Radio resource admission control

When UTRAN receives a request to establish or modify a radio access bearer from the CN, the current radio resource situation is analysed and the admission control either accepts or rejects the request. This is called "Radio resource

admission control" and is handled by the UTRAN. If the request is queued, it is handled by the RAB queuing, pre-emption and priority function.

5.3.2 Broadcast information management

This function consists in the broadcast from network toward UE of some information in the coverage area of the whole network or different parts of the network.

There are two kinds of Broadcast information management. UTRAN broadcast information, and Cell Broadcast information management. All UTRAN broadcast information management shall be handled locally within UTRAN. All Cell Broadcast information is controlled by CN and executed by UTRAN.

5.4 I_u link Management functions

5.4.1 I_u Signalling Link Management function

The I_u signalling link management function provides a reliable transfer of the radio network signalling between UTRAN and CN. Both CN and UTRAN manage the function.

This function is in particular responsible for I_u signalling connection establishment, which can be established either by the CN or the RNC and for I_u signalling connection release, which is controlled by CN possibly upon UTRAN request.

5.4.2 ATM Virtual Connection Management function

This function refers to handling of ATM Virtual Connections (VCs) between CN and UTRAN.

This function shall be used to establish, maintain and release the ATM VCs. For permanent VCs, it is regarded to be an O&M function.

This function also includes the selection of a Virtual Circuit to be used for a particular RAB. The selection of ATM VC upon an I_u radio access bearer service request, shall be done by UTRAN. The selected VC shall fulfil the requirements of the request. The VC may consist of several sublinks: such as SCCP connections, AAL2 connections or IP flows.

5.4.3 AAL2 connection establish and release function

This function is used to establish and release the AAL type 2 connections between CN and UTRAN upon an I_u radio access bearer service request. Both UTRAN and CN are taking part in the establishment of AAL2 connection. UTRAN shall initiate both establishment and release of AAL2 connections. In abnormal cases, the CN may also initiate release of AAL2 connections. The use of AAL2 for I_u transmission bearers depends on type of CN.

5.4.4 AAL5 management function

AAL5 connections between CN and UTRAN shall be pre-configured at system initialisation. Basic configuration is PVCs. For user data, SVC is possible.

The AAL5 management is a function handled by both the CN and the UTRAN.

5.4.5 GTP-U tunnels management function

This function is used to establish and release GTP-U tunnels between CN and UTRAN upon a radio access bearer service request. This involves assigning a tunnel identifier for each direction and the creation of a context containing the tunnel information. The tunnel identifier for the downlink is allocated by the UTRAN, and the tunnel identifier for the uplink is allocated by the CN. Both CN and UTRAN should maintain the context. The use of GTP-U for I_u transport bearers depends on type of CN.

5.4.6 TCP Management Function

This function is used to establish and release the TCP connections between CN and UTRAN over I_u-BC.

The TCP management function exists in both UTRAN and CN.

5.4.7 Buffer Management

Congestion control shall be performed over the Iu user plane using buffer management and no flow control.

This function includes buffers to store received packet data units that at reception can not be processed due to e.g. congestion. In UTRAN, there must be a buffer management function handling received packets from the peer CN node.

The used mechanism is not in the scope of the present document and not relevant to be standardised.

Buffer management is a UTRAN function.

5.4.8 RTP Session Management Function

This function is used to establish and release RTP sessions between CN and UTRAN upon a radio access bearer service request. This involves assigning a RTP session identifier for each direction and the creation of a context containing the RTP session information. The RTP session identifier for the downlink is allocated by the UTRAN, and the RTP session identifier for the uplink is allocated by the CN. Both CN and UTRAN should maintain the RTP session context. The use of RTP for Iu transport bearers depends on type of CN.

5.5 I_u U-plane (RNL) Management Functions

5.5.1 I_u U-plane frame protocol mode selection function

The I_u UP in the Radio Network Layer provides modes of operation that can be activated on RAB basis. For a given RAB, the I_u UP operates either in a Transparent or in Support mode. I_u U-plane frame protocol mode is selected by the CN. A set of appropriate U-plane version(s) is indicated within RANAP. The final U-plane version is selected during the Iu UP initiation procedure among the indicated version(s).

This function is a CN function.

5.5.2 I_u U-plane frame protocol initialisation

I_u U-plane frame protocol is initialised by the UTRAN. In certain cases, as described in TS 23.153 [15], the I_u U-plane frame protocol may be initialised by the CN.

5.6 Mobility Management Functions

5.6.1 Location information update function

Some functionality within the CN, needs information about the present location of an active UE, i.e. a UE with established signalling connection. The Location information update function is used to transfer this information from the UTRAN to the CN. It is the UTRAN responsibility to send this information initially at the signalling connection establishment for a UE and at any change of the UE location as long as the signalling connection exists. For this function, the location information shall be at Location and Routing Area level.

5.6.2 Handover and Relocation functions

5.6.2.1 Inter RNC hard HO function, Iur not used or not available

This functionality includes procedures for handover from one RNC to another RNC when Iur interface is not used or is not available, i.e. soft handover is not possible. The connection is switched in the CN, so both UTRAN and CN are involved. Both intra and inter CN entity cases are applicable. This functionality includes also the moving of the Serving RNS functionality from one RNC to another RNC.

5.6.2.2 Serving RNS Relocation function

This functionality allows moving the Serving RNS functionality from one RNC to another RNC, e.g. closer to where the UE has moved during the communication. The Serving RNS Relocation procedure may be applied when active cell management functionality has created a suitable situation for it. Both UTRAN and CN are involved.

5.6.2.3 Inter system Handover (e.g. UMTS-GSM) function

Inter system handover is performed when a mobile hands over between cells belonging to different systems such as GSM and UMTS. For intersystem handover between UMTS and GSM, the GSM procedures are used within the GSM network. Both UTRAN and CN are involved.

NOTE: The GSM BSSMAP procedures are outside the scope of the present document.

5.6.2A Inter System Change (e.g. UMTS-GSM) function

Inter system change is performed when a GPRS attached mobile moves from cells belonging to different systems such as GSM and UMTS. For intersystem change between UMTS and GSM, the GPRS procedures are used within the GPRS network. Both UTRAN and CN are involved.

5.6.3 Paging Triggering

The Core Network shall, when considered necessary, trigger the Location/Routing/RNC Area paging in the UTRAN system.

5.6.4 Shared Networks Access Control

The Shared Networks Access Control function allows the CN to request the UTRAN to apply UE specific access control to the UTRAN and the neighbouring networks on a PLMN or an SNA basis. The Shared Networks Access Control function is further described in TS 25.401 [1].

5.6.5 GERAN System Information Retrieval

In order to provide the UE with system information related to NACC towards a GERAN system - to be used as an optimisation - the GERAN System Information Retrieval function allows the source system to request GERAN (via CN) to provide this system information. The request and subsequent transfer of the GERAN System Information is performed transparently with the RIM function. The RIM function is further described in TS 25.401 [1]

5.7 Security Functions

5.7.1 Data Confidentiality

5.7.1.1 Radio interface ciphering function

The radio interface shall be ciphered upon request of the Core Network. Both Signalling and user data may be subject to ciphering. The ciphering shall be done within UTRAN.

5.7.1.2 Ciphering key management function

The ciphering key and the permitted algorithm shall be supplied by the CN. UTRAN selects the used algorithm.

5.7.2 Data integrity

5.7.2.1 Integrity checking

The purpose of the integrity check is to make sure that the signalling continues between the same elements as by authentication. The integrity check shall be done within the UTRAN.

5.7.2.2 Integrity key management

The integrity key and the permitted algorithm shall be supplied by the CN. UTRAN selects the used algorithm.

5.8 Service and Network Access Functions

5.8.1 Core Network signalling data transfer function

The NAS CN signalling data such as Call Control (CC), Session Management (SM), Mobility Management (MM), Short Message Services Point to Point and Supplementary Services (SS) shall be transparently conveyed between the CN and the UE. Over the Iu interface, the same Iu interface channel that is used for the UTRAN-CN signalling shall be used.

5.8.2 Data Volume Reporting

The data volume reporting function is used to report the volume of unacknowledged data to the CN. The function shall be in the UTRAN and is triggered from the CN.

5.8.3 UE Tracing

This feature allows tracing of various events related to the UE and its activities. This is an O&M functionality.

5.8.4 Location reporting function

The positioning function performs the determination of the geographical position and optionally the velocity for an UE. The location reporting function transfers the positioning information between the UTRAN and the CN according to CN commands. This function involves UTRAN and CN.

5.8.5 MDT

This feature enables the transfer of MDT measurements collected by the UE, as defined in TS 37.320 [30]. This is an O&M functionality.

5.9 Co-ordination Functions

5.9.1 Paging Co-ordination function

The two CN domain architecture implies need for a page co-ordination, i.e. handling of page triggered by one CN node when UE has a signalling connection to the other CN node. The paging co-ordination is performed by UTRAN and/or optionally by CN. The Common ID is used for UTRAN paging co-ordination. The CN provides the UTRAN with the Common ID.

The paging co-ordination is a UTRAN function. Optionally the paging co-ordination may be performed in the CN.

5.9.2 NAS Node Selection Function

The optional NAS Node Selection Function enables the RNC to initially assign CN resources to serve a UE and subsequently setup a signalling connection to the assigned CN resource.

The method by which the RNC initially assigns CN resources is implementation dependent.

The NNSF is described in detail in TS 23.236 [25].

5.9.3 Information Transfer Function

The Information Transfer function allows configuration data to be passed from the CN to the RNC upon CN trigger. This function is operated in acknowledged mode. It should be used by the CN to maintain alignment between the data as configured in the CN and the configuration data provided to the UTRAN. This may be used e.g. to coordinate the SNA geographical definition (LA to SNA mapping) between CN and UTRAN in order to apply access control on an SNA basis.

5.9.4 MOCN Rerouting Function

Rerouting is a mechanism used as part of the assignment of CN operator in shared networks with MOCN configuration for network sharing non-supporting UEs when they perform initial attach /registration. In this case RNC may not know towards which CN to route the initial UE request message and the latter may be rerouted to another CN via RNC.

The MOCN Rerouting Function is described in detail in TS 23.251 [26].

5.9.5 SIPTO at Iu-PS Function

If supported, SIPTO at Iu-PS Function provides the capability to offload certain PS RABs from the CN at RAB setup. The SIPTO at Iu-PS is implementation dependent and may be implemented in a separate entity outside of RNS, for further information see TS 23.060 [29].

5.10 MBMS Functions

5.10.1 MBMS RAB Management functions

The MBMS RAB, Radio Access Bearer, is defined to be set-up between the CN and one or several UEs for MBMS. Depending on the MBMS service characteristics, different types of MBMS RABs will be used. It is the CN that controls towards the UTRAN the establishment, update or release of an MBMS RAB. The MBMS RAB is defined for the PS domain only.

5.10.2 MBMS UE Linking Function

This function provides the RNC with the list of MBMS services that a given UE, with existing dedicated Iu-PS signalling connection, has “joined” or has “left” TS 23.246 [27].

5.10.3 MBMS Registration Control Function

This function allows the RNC to either register or deregister to the PS core network domain for a specific MBMS bearer service so that it is notified whenever a session of this service starts.

It also allows the CN to inform the RNC that a given MBMS bearer service is no longer available.

5.10.4 MBMS Enquiry Function

This function allows the RNC to request to the SGSN the list of MBMS bearer services that a given UE has “joined” TS 23.246 [27] or the IP Multicast Address and APN defined in TS 23.246 [27] which correspond to a given MBMS bearer service.

6 I_u Interface Protocol Structure

6.1 General

The Radio Network signalling over I_u consists of the Radio Access Network Application Part (RANAP). The RANAP protocol consists of mechanisms to handle all procedures between the CN and UTRAN. It is also capable of conveying messages transparently between the CN and the UE without interpretation or processing by the UTRAN.

Over the I_u interface the RANAP protocol is, e.g. used for:

- Facilitate a set of general UTRAN procedures from the Core Network such as paging -notification as defined by the notification SAP in TS 23.110 [3].
- Separate each User Equipment (UE) on the protocol level for mobile specific signalling management as defined by the dedicated SAP in TS 23.110 [3].
- Transfer of transparent non-access signalling as defined in the dedicated SAP in TS 23.110 [3].
- Request of various types of UTRAN Radio Access Bearers through the dedicated SAP in TS 23.110 [3].
- Perform the SRNS Relocation function.
- Perform the various MBMS procedures.
- Perform SIPTO at I_u-PS (optional).

The Radio Access Bearers are provided by the Access Stratum.

Over I_u-BC, a datagram mechanism is used, so there is no clear separation of control and user planes, and the SABP protocol is used for data transfer and signalling.

6.2 Iu-CS

Figure 6.1 shows the protocol structure for I_u-CS, following the structure described in TS 25.401 [1].

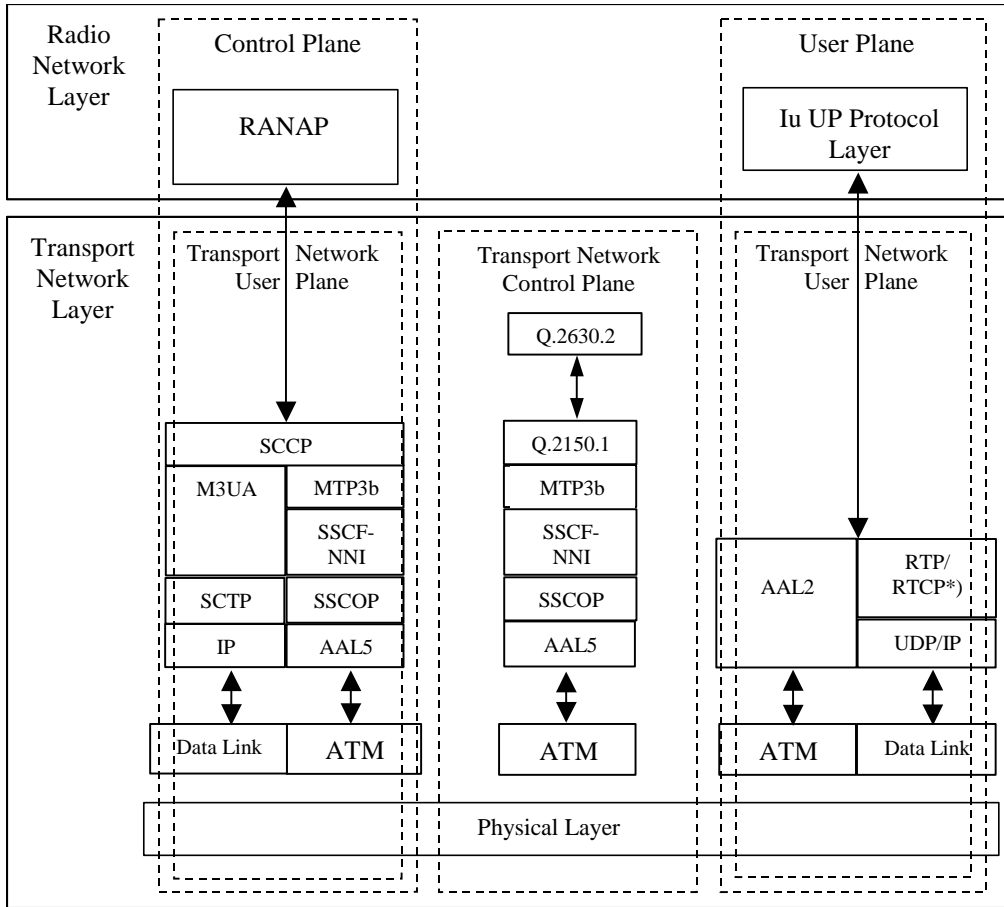

*) RTCP is optional.

Figure 6.1: I_u –Interface Protocol Structure towards CS Domain

6.3 I_u-BC

Figure 6.2 shows the protocol structure for the I_u-BC.

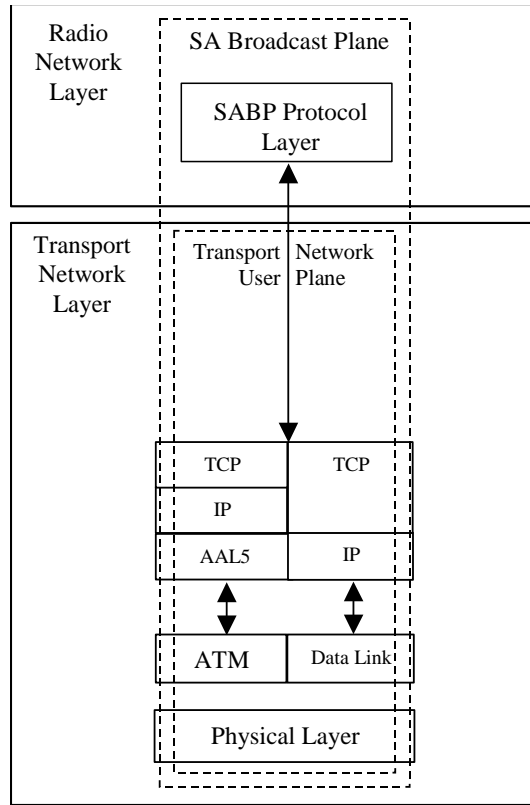

Figure 6.2: I_u Interface Protocol Structure towards Broadcast Domain

6.4 I_u-PS

Figure 6.3 shows the protocol structure for Iu-PS, following the structure described in TS 25.401 [1].

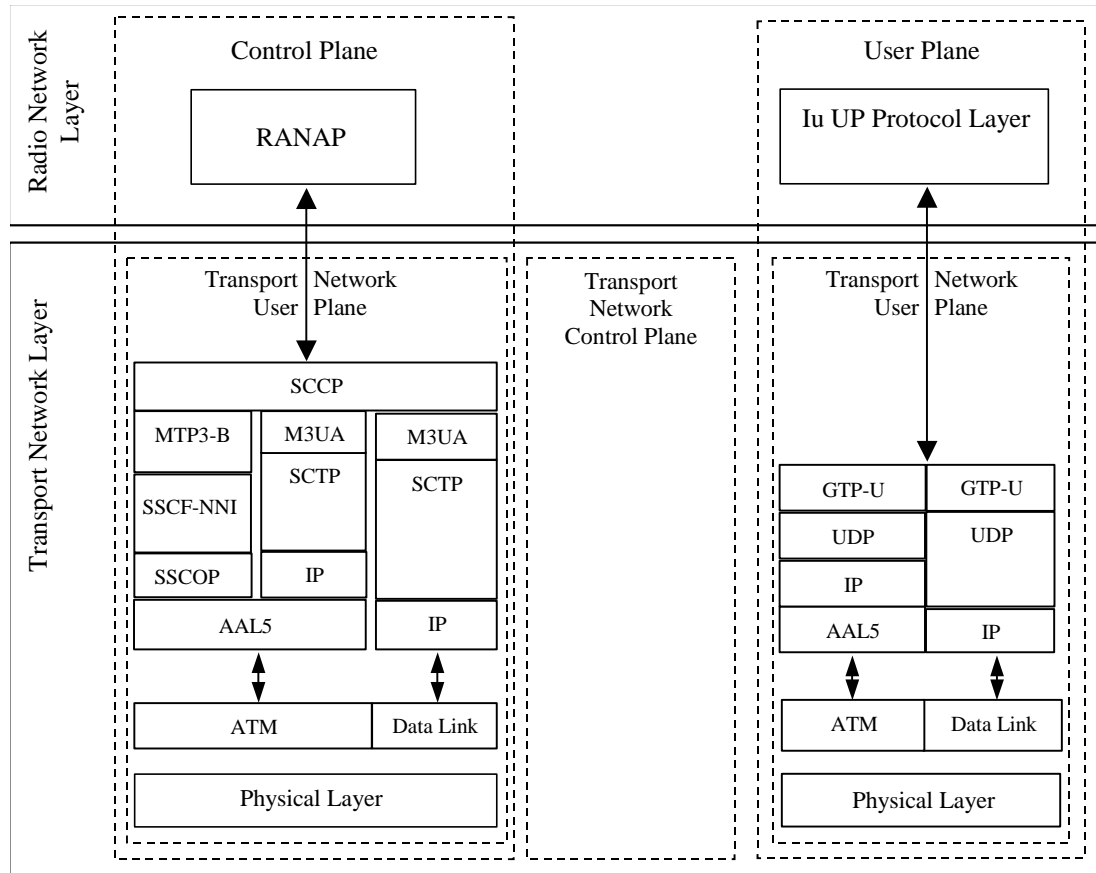

Figure 6.3: I_u Interface Protocol Structure towards PS Domain

7 Other I_u Interface Specifications

7.1 UTRAN I_u Interface: Layer 1 (3GPP TS 25.411)

TS 25.411 [4] specifies the range of physical layer technologies that may be used to support the Iu interface.

7.2 UTRAN I_u Interface: Signalling Transport (3GPP TS 25.412)

TS 25.412 [5] specifies the signalling bearers for the RANAP and transport network control plane protocols for both Iu-PS and Iu-CS.

7.3 UTRAN I_u Interface: RANAP Specification (3GPP TS 25.413)

TS 25.413 [6] specifies the RANAP protocol for radio network control plane signalling over the Iu interface.

7.4 UTRAN I_u Interface: Data Transport and Transport Signalling (3GPP TS 25.414)

TS 25.414 [7] specifies the transport bearers for the user plane of the Iu interface. It also specifies the protocol used to control these transport bearers.

7.5 UTRAN I_u Interface: CN-UTRAN User Plane Protocol (3GPP TS 25.415)

TS 25.415 [8] specifies the user plane frame handling protocol for the Iu interface.

7.6 UTRAN I_u Interface: Service Area Broadcast Protocol SABP (3GPP TS 25.419)

TS 25.419 [14] specifies the communication requirements over the Iu interface towards the BC domain.

7.7 Summary

The present document, 3GPP TS 25.410, specifies the general aspects and principles of the I_u interface as a whole.

The relationship between the other technical specifications that define the UTRAN Iu interface is shown in figure 7.1.

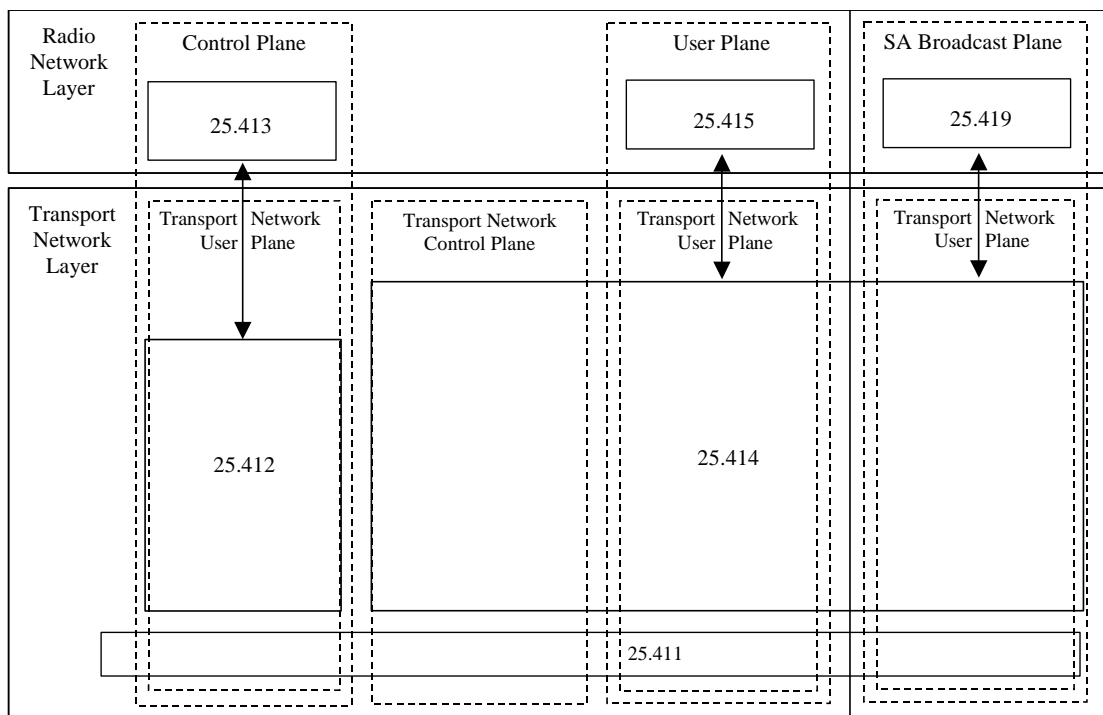

Figure 7.1: Summary of Iu Interface Specification Structure

Annex A (informative): Change History

Date / TSG	TSG Doc	CR	Rev	Subject/Comment	New
12/2008	-	-	-	Creation of Rel-8 version based on v7.0.0	8.0.0
RP-43	RP-090078	0068	1	RANAP: Enhanced Relocation Complete Request in SCCP: Connection Request	8.1.0
12/2009	-	-	-	Created version 9.0.0 based on v. 8.1.0	9.0.0
12/2010	-	-	-	Created version 10.0.0 based on v. 9.0.0	10.0.0
RP-50	RP-101389	0070	-	Introduction of the SIPTO at Iu-PS Function	10.0.0
SP-49	SP-100629	-	-	Clarification on the use of References (TS 21.801 CR#0030)	10.1.0
RP-51	RP-110230	0074	1	Support for MDT	10.1.0
RP-52	RP-110684	0075	-	Correction of references	10.2.0
09/2012	-	-	-	Update to Rel-11 version (MCC)	11.0.0