

3GPP TS 25.302 V11.4.0 (2013-06)

Technical Specification

3rd Generation Partnership Project; Technical Specification Group Radio Access Network; Services provided by the physical layer (Release 11)



The present document has been developed within the 3rd Generation Partnership Project (3GPP™) and may be further elaborated for the purposes of 3GPP. The present document has not been subject to any approval process by the 3GPP Organisational Partners and shall not be implemented. This Specification is provided for future development work within 3GPP only. The Organisational Partners accept no liability for any use of this Specification. Specifications and reports for implementation of the 3GPP™ system should be obtained via the 3GPP Organisational Partners' Publications Offices.

Keywords

UMTS, services, radio, layer 1

3GPP

Postal address

3GPP support office address

650 Route des Lucioles - Sophia Antipolis
Valbonne - FRANCE
Tel.: +33 4 92 94 42 00 Fax: +33 4 93 65 47 16

Internet

<http://www.3gpp.org>

Copyright Notification

No part may be reproduced except as authorized by written permission.
The copyright and the foregoing restriction extend to reproduction in all media.

© 2013, 3GPP Organizational Partners (ARIB, ATIS, CCSA, ETSI, TTA, TTC).
All rights reserved.

UMTS™ is a Trade Mark of ETSI registered for the benefit of its members
3GPP™ is a Trade Mark of ETSI registered for the benefit of its Members and of the 3GPP Organizational Partners
LTE™ is a Trade Mark of ETSI currently being registered for the benefit of its Members and of the 3GPP Organizational Partners
GSM® and the GSM logo are registered and owned by the GSM Association

Contents

Foreword	7
1 Scope	8
2 References.....	8
3 Definitions and abbreviations	8
3.1 Definitions	8
3.2 Abbreviations	10
4 Interfaces to the physical layer	11
4.1 Interface to MAC.....	12
4.2 Interface to RRC	12
5 Services and functions of the physical layer	12
5.1 General	12
5.2 Overview of L1 functions	13
5.3 L1 interactions with L2 retransmission functionality	13
6 Model of physical layer of the UE.....	14
6.1 Uplink models	14
6.2 Downlink models.....	19
7 Formats and configurations for L1 data transfer	33
7.1 General concepts about Transport Channels.....	33
7.1.1 Transport Block	33
7.1.2 Transport Block Set	33
7.1.3 Transport Block Size	34
7.1.4 Transport Block Set Size	34
7.1.5 Transmission Time Interval.....	34
7.1.6 Transport Format	35
7.1.6a Transport Format for HS-DSCH	35
7.1.7 Transport Format for E-DCH.....	36
7.1.7a Transport Format Set	36
7.1.8 Transport Format Combination	37
7.1.9 Transport Format Combination Set	37
7.1.10 Transport Format Indicator (TFI)	38
7.1.11 Transport Format Combination Indicator (TFCI).....	38
7.1.12 Rate matching	39
7.1.13 HARQ information	39
7.1.14 Transport Format and Resource Indication (TFRI).....	39
7.1.15 E-DCH Transport Format Combination Indication (E-TFCI).....	39
7.2 Types of Transport Channels.....	39
7.3 Compressed Mode.....	42
8 UE Simultaneous Physical Channels combinations	43
8.1 FDD Uplink	43
8.2 FDD Downlink.....	46
8.3 TDD Uplink.....	56
8.3.1 3.84/7.68 Mcps TDD Uplink	56
8.3.2 1.28 Mcps TDD Uplink.....	58
8.4 TDD Downlink	60
8.4.1 3.84/7.68 Mcps TDD Downlink	60
8.4.2 1.28 Mcps TDD Downlink	61
8.4.3 3.84 Mcps TDD IMB Downlink.....	66
9 Measurements provided by the physical layer	66
9.1 Model of physical layer measurements	67
9.2 UE Measurements	68
9.2.1 SFN-CFN observed time difference	68

9.2.2	Void	68
9.2.3	CPICH E_c/N_0	69
9.2.4	Void	69
9.2.5	CPICH RSCP	69
9.2.6	P-CCPCH RSCP	69
9.2.7	Timeslot ISCP	69
9.2.8	Void	69
9.2.9	SIR	69
9.2.10	UTRA carrier RSSI	70
9.2.11	GSM carrier RSSI	70
9.2.12	Transport channel BLER	70
9.2.13	UE transmitted power	70
9.2.14	UE Rx-Tx time difference	70
9.2.15	SFN-SFN Observed time difference	71
9.2.16	UE GPS Timing of Cell Frames for UE positioning	71
9.2.17	Timing Advance (T_{ADV}) for 1.28 Mcps TDD	71
9.2.18	UE GPS code phase	71
9.2.19	UE GANSS Timing of Cell Frames for UE positioning	72
9.2.20	UE GANSS code measurement	72
9.2.21	UE transmission power headroom	72
9.3	UTRAN Measurements	72
9.3.1	Received total wide band power	72
9.3.2	Transmitted carrier power	73
9.3.3	Transmitted code power	73
9.3.4	Void	73
9.3.5	Physical channel BER	73
9.3.6	Transport channel BER	73
9.3.7	RX timing deviation	73
9.3.8	Timeslot ISCP	74
9.3.9	RSCP	74
9.3.10	Round Trip Time	74
9.3.11	Void	74
9.3.12	Acknowledged PRA CH preambles	74
9.3.13	Void	74
9.3.14	Void	74
9.3.15	SIR	75
9.3.16	PRA CH Propagation Delay	75
9.3.17	UTRAN GPS Timing of Cell Frames for UE positioning	75
9.3.18	SIR ERROR	75
9.3.19	Received SYNC_UL Timing Deviation	75
9.3.20	Cell Sync Burst Timing	76
9.3.21	Cell Sync Burst SIR	76
9.3.22	SFN-SFN Observed time difference	76
9.3.23	Angle of Arrival (AOA) for 1.28 Mcps TDD	76
9.3.24	HS-SICH reception quality	76
9.3.25	Transmitted carrier power of all codes not used for HS-PDSCH, HS-SCCH, E-AGCH, E-RGCH or E-HICH transmission	77
9.3.26	UpPTS interference (1.28Mcps TDD)	77
9.3.27	DL Transmission Branch Load	77
9.3.28	Received scheduled E-DCH power share (RSEPS)	78
9.3.29	UTRAN GANSS Timing of Cell Frames for UE positioning	78
9.3.30	Common E-DCH resource usage	79
10	Primitives of the physical layer	79
10.1	Generic names of primitives between layers 1 and 2	80
10.1.1	PHY-Access-REQ	80
10.1.2	PHY-Access-CNF	81
10.1.3	PHY-Data-REQ	81
10.1.4	PHY-Data-IND	81
10.1.5	Void	82
10.1.6	Void	82
10.1.7	PHY-Status-IND	82

10.2	Generic names of primitives between layers 1 and 3	82
10.2.1	STATUS PRIMITIVES	82
10.2.1.1	CPHY-Sync-IND	82
10.2.1.2	CPHY-Out-of-Sync-IND	83
10.2.1.3	CPHY-Measurement-REQ	83
10.2.1.4	CPHY-Measurement-IND	83
10.2.1.5	CPHY-Error-IND	83
10.2.1.6	Void	83
10.2.2	CONTROL PRIMITIVES	83
10.2.2.1	CPHY-TrCH-Config-REQ	84
10.2.2.2	CPHY-TrCH-Config-CNF	84
10.2.2.3	CPHY-TrCH-Release-REQ	84
10.2.2.4	CPHY-TrCH-Release-CNF	84
10.2.2.5	CPHY-RL-Setup-REQ	84
10.2.2.6	CPHY-RL-Setup-CNF	84
10.2.2.7	CPHY-RL-Release-REQ	84
10.2.2.8	CPHY-RL-Release-CNF	84
10.2.2.9	CPHY- RL-Modify-REQ	85
10.2.2.10	CPHY-RL-Modify-CNF	85
10.2.2.11	CPHY-Commit-REQ	85
10.2.2.12	Void	85
10.2.2.13	Void	85
10.2.2.14	Void	85
10.2.2.15	Void	85
10.2.2.16	CPHY-Out-of-Sync-Config-REQ	85
10.2.2.17	CPHY-Out-of-Sync-Config-CNF	85
10.2.2.18	CPHY-MBMS-Config-REQ	86
10.2.2.19	CPHY-MBMS-Config-CNF	86
10.3	Parameter definition	86
10.3.1	Error code	86
10.3.2	Event value	86
10.3.3	Access Information	86
10.3.4	Transport Format Subset	86
10.3.5	Physical channel description	87
10.3.5.1	Primary SCH	87
10.3.5.2	Secondary SCH	87
10.3.5.3	Primary CCPCH	87
10.3.5.4	Secondary CCPCH	87
10.3.5.4a	Secondary CCPCH frame type 2	87
10.3.5.5	PRA CH	88
10.3.5.6	Uplink DPDCH+DPCCH	88
10.3.5.7	Uplink DPCH	88
10.3.5.8	Downlink DPCH	89
10.3.5.8a	F-DPCH (FDD only)	89
10.3.5.9	Void	89
10.3.5.10	PICH	89
10.3.5.11	AICH	89
10.3.5.12	Void	90
10.3.5.13	Void	90
10.3.5.14	Void	90
10.3.5.15	Void	90
10.3.5.16	PDSCH (TDD only)	90
10.3.5.17	PUSCH	90
10.3.5.18	DwPCH (1.28 Mcps TDD only)	91
10.3.5.19	UpPCH (1.28 Mcps TDD only)	91
10.3.5.20	FPACH (1.28 Mcps TDD only)	91
10.3.5.21	PNBSCH (Physical Node B Synchronisation channel)	91
10.3.5.22	HS-SCCH	91
10.3.5.23	HS-SICH (TDD only)	91
10.3.5.24	E-AGCH	91
10.3.5.25	E-DPCCH (FDD only)	92
10.3.5.26	E-DPDCH (FDD only)	92

10.3.5.27	E-HICH.....	92
10.3.5.28	E-RGCH (FDD only)	92
10.3.5.28a	E-RUCCH (TDD only).....	92
10.3.5.29	MICH.....	92
10.3.6	Feedback information	93
10.3.7	HARQ process	93
10.3.8	HS-DSCH information	93
10.3.9	HARQ status.....	93
10.3.10	E-DCH information	93
10.3.11	MBMS information.....	93
11	Transport block transmission	94
Annex A (normative):	Description of Transport Formats	95
Annex B (informative):	Example of Transport format attributes for AMR speech codec.....	98
Annex C (informative):	Change history.....	99

Foreword

This Technical Specification (TS) has been produced by the 3rd Generation Partnership Project (3GPP).

The contents of the present document are subject to continuing work within the TSG and may change following formal TSG approval. Should the TSG modify the contents of the present document, it will be re-released by the TSG with an identifying change of release date and an increase in version number as follows:

Version x.y.z

where:

- x the first digit:
 - 1 presented to TSG for information;
 - 2 presented to TSG for approval;
 - 3 or greater indicates TSG approved document under change control.
- y the second digit is incremented for all changes of substance, i.e. technical enhancements, corrections, updates, etc.
- z the third digit is incremented when editorial only changes have been incorporated in the document.

1 Scope

The present document is a technical specification of the services provided by the physical layer of UTRA to upper layers.

2 References

The following documents contain provisions which, through reference in this text, constitute provisions of the present document.

- References are either specific (identified by date of publication, edition number, version number, etc.) or non-specific.
- For a specific reference, subsequent revisions do not apply.
- For a non-specific reference, the latest version applies. In the case of a reference to a 3GPP document (including a GSM document), a non-specific reference implicitly refers to the latest version of that document *in the same Release as the present document*.

- [1] 3GPP TS 23.110: "UMTS Access Stratum; Services and Functions".
- [2] 3GPP TS 25.301: "Radio Interface Protocol Architecture".
- [3] 3GPP TS 25.212: "Multiplexing and channel coding (FDD)".
- [4] 3GPP TS 25.222: "Multiplexing and channel coding (TDD)".
- [5] 3GPP TS 25.224: "Physical Layer Procedures (TDD)".
- [6] 3GPP TS 25.215: "Physical Layer – Measurements (FDD)".
- [7] 3GPP TS 25.213: "Spreading and modulation (FDD)".
- [8] 3GPP TS 25.214: "Physical layer procedures (FDD)".
- [9] 3GPP TS 25.123: "Requirements for Support of Radio Resource Management (TDD)".
- [10] 3GPP TS 25.133: "Requirements for Support of Radio Resource Management (FDD)".
- [11] 3GPP TS 25.225: "Physical Layer – Measurements (TDD)".
- [12] 3GPP TS 25.221: "Physical channels and mapping of transport channels onto physical channels (TDD)".
- [13] 3GPP TS 25.331: "Radio Resource Control (RRC); protocol specification".
- [14] 3GPP TS 25.346: "Introduction of the Multimedia Broadcast Multicast Service (MBMS) in the Radio Access Network (RAN); Stage 2".

3 Definitions and abbreviations

3.1 Definitions

For the purposes of the present document, the terms and definitions given in [3] and the following apply:

E-DCH active set (FDD only): The set of cells which carry the E-DCH for one UE. In CELL_FACH state and Idle mode, the E-DCH active set contains the Serving E-DCH cell only.

Serving E-DCH cell: Cell from which the UE receives Absolute Grants from the Node-B scheduler. A UE has one Serving E-DCH cell.

Serving E-DCH RLS or Serving RLS (FDD only): Set of cells which contains at least the Serving E-DCH cell and from which the UE can receive and combine one Relative Grant. The UE has only one Serving E-DCH RLS.

Non-serving E-DCH RL or Non-serving RL (FDD only): Cell which belongs to the E-DCH active set but does not belong to the Serving E-DCH RLS and from which the UE can receive one Relative Grant. The UE can have zero, one or several Non-serving E-DCH RL(s).

Primary downlink frequency: If a single downlink frequency is configured for the UE, then it is the primary downlink frequency. In case more than one downlink frequency is configured for the UE, then the primary downlink frequency is the frequency on which the Serving HS-DSCH cell is transmitted.

Secondary downlink frequency: In case more than one downlink frequency is configured for the UE, then a secondary downlink frequency is a frequency on which a secondary Serving HS-DSCH cell is transmitted.

Activated uplink frequency: For a specific UE, an uplink frequency is said to be activated if the UE is allowed to transmit on that frequency. The primary uplink frequency is always activated when configured while a secondary uplink frequency has to be activated by means of an HS-SCCH order in order to become activated.

Configured uplink frequency: For a specific UE, an uplink frequency is said to be configured if the UE has received all relevant information from higher layers in order to perform transmission on that frequency.

Primary uplink frequency: If a single uplink frequency is configured for the UE, then it is the primary uplink frequency. In case more than one uplink frequency is configured for the UE, then the primary uplink frequency is the frequency on which the E-DCH corresponding to the serving E-DCH cell associated with the serving HS-DSCH cell is transmitted. The association between a pair of uplink and downlink frequencies is indicated by higher layers.

Secondary uplink frequency: A secondary uplink frequency is a frequency on which an E-DCH corresponding to a serving E-DCH cell associated with a secondary serving HS-DSCH cell is transmitted. The association between a pair of uplink and downlink frequencies is indicated by higher layers.

1st Secondary serving HS-DSCH cell: If the UE is configured with two uplink frequencies, the 1st secondary serving HS-DSCH cell is the secondary serving HS-DSCH cell that is associated with the secondary uplink frequency. If the UE is configured with a single uplink frequency, the 1st secondary serving HS-DSCH cell is a secondary serving HS-DSCH cell whose index is indicated by higher layers.

2nd Secondary serving HS-DSCH cell: If the UE is configured with more than two serving HS-DSCH cells, the 2nd secondary serving HS-DSCH cell is a secondary serving HS-DSCH cell whose index is indicated by higher layers.

3rd Secondary serving HS-DSCH cell: If the UE is configured with four or more serving HS-DSCH cells, the 3rd secondary serving HS-DSCH cell is a secondary serving HS-DSCH cell whose index is indicated by higher layers.

4th Secondary serving HS-DSCH cell: If the UE is configured with five or more serving HS-DSCH cells, the 4th secondary serving HS-DSCH cell is a secondary serving HS-DSCH cell whose index is indicated by higher layers.

5th Secondary serving HS-DSCH cell: If the UE is configured with six or more serving HS-DSCH cells, the 5th secondary serving HS-DSCH cell is a secondary serving HS-DSCH cell whose index is indicated by higher layers.

6th Secondary serving HS-DSCH cell: If the UE is configured with seven or more serving HS-DSCH cells, the 6th secondary serving HS-DSCH cell is a secondary serving HS-DSCH cell whose index is indicated by higher layers.

7th Secondary serving HS-DSCH cell: If the UE is configured with eight serving HS-DSCH cells, the 7th secondary serving HS-DSCH cell is a secondary serving HS-DSCH cell whose index is indicated by higher layers.

Multiflow (FDD only): A mode of operation with two simultaneous HS-DSCH transport channels per carrier frequency, where the HS-DSCH transport channels may belong to the same or different Node Bs.

Assisting serving HS-DSCH Cell: In addition to the serving HS-DSCH cell, a cell in the same frequency, where the UE is configured to simultaneously monitor a HS-SCCH set and receive HS-DSCH if it is scheduled in that cell.

Assisting secondary serving HS-DSCH Cell: In addition to the serving HS-DSCH cell, a cell in the secondary downlink frequency, where the UE is configured to simultaneously monitor a HS-SCCH set and receive HS-DSCH if it is scheduled in that cell.

3.2 Abbreviations

For the purposes of the present document, the following abbreviations apply:

ARQ	Automatic Repeat Request
BCCH	Broadcast Control Channel
BCH	Broadcast Channel
C-	Control-
CC	Call Control
CCCH	Common Control Channel
CCH	Control Channel
CCTrCH	Coded Composite Transport Channel
CLTD	Closed Loop Transmit Diversity
CN	Core Network
CQI	Channel Quality Indicator
CRC	Cyclic Redundancy Check
DC	Dedicated Control (SAP)
DCA	Dynamic Channel Allocation
DCCH	Dedicated Control Channel
DCH	Dedicated Channel
DL	Downlink
DRNC	Drift Radio Network Controller
DSCH	Downlink Shared Channel
DTCH	Dedicated Traffic Channel
E-AGCH	E-DCH Absolute Grant Channel
E-DCH	Enhanced DCH
E-DPCCH	E-DCH Dedicated Physical Control Channel (FDD only)
E-DPDCH	E-DCH Dedicated Physical Data Channel (FDD only)
E-HICH	E-DCH HARQ Acknowledgement Indicator Channel
E-PUCH	E-DCH Physical Uplink Channel (TDD only)
E-RGCH	E-DCH Relative Grant Channel (FDD only)
E-ROCH	E-DCH Rank and Offset Channel (FDD only)
E-RUCCH	E-DCH Random access Uplink Control Channel (TDD only)
E-TFC	E-DCH Transport Format Combination
E-UCCH	E-DCH Uplink Control Channel (3.84 Mcps and 7.68 Mcps TDD only)
FACH	Forward Link Access Channel
FCS	Frame Check Sequence
FDD	Frequency Division Duplex
F-DPCH	Fractional Dedicated Physical Channel (FDD only)
F-TPICH	Fractional Transmitted Precoding Indicator Channel
GC	General Control (SAP)
GNSS	Galileo and Additional Navigation Satellite Systems
GNSS	Global Navigation Satellite System
GPS	Global Positioning System
HARQ	Hybrid Automatic Repeat Request
HS-DPCCH	High Speed Dedicated Physical Control Channel
HS-DSCH	High Speed Downlink Shared Channel
HS-SCCH	High Speed Shared Control Channel
HS-SICH	High Speed Shared Information Channel
HO	Handover
ITU	International Telecommunication Union
kbps	kilo-bits per second
L1	Layer 1 (physical layer)
L2	Layer 2 (data link layer)
L3	Layer 3 (network layer)
LAC	Link Access Control
LAI	Location Area Identity
MAC	Medium Access Control
MBMS	Multimedia Broadcast Multicast Service
MCCH	MBMS point-to-multipoint Control Channel
MICH	MBMS notification Indicator Channel
MM	Mobility Management

MSCH	MBMS point-to-multipoint Scheduling Channel
MTCH	MBMS point-to-multipoint Traffic Channel
Nt	Notification (SAP)
PCCH	Paging Control Channel
PCH	Paging Channel
PDU	Protocol Data Unit
PHY	Physical layer
PhyCH	Physical Channels
RACH	Random Access Channel
RLC	Radio Link Control
RNC	Radio Network Controller
RNS	Radio Network Subsystem
RNTI	Radio Network Temporary Identity
RRC	Radio Resource Control
SAP	Service Access Point
S-DPCCH	Secondary Dedicated Physical Control Channel
SDU	Service Data Unit
S-E-DPCCH	Secondary E-DPCCH (FDD only)
S-E-DPDCH	Secondary E-DPDCH (FDD only)
SRNC	Serving Radio Network Controller
SRNS	Serving Radio Network Subsystem
SS	Synchronisation Shift
TCH	Traffic Channel
TDD	Time Division Duplex
TFCI	Transport Format Combination Indicator
TFI	Transport Format Indicator
TFRI	Transport Format and Resource Indicator
TMSI	Temporary Mobile Subscriber Identity
TPC	Transmit Power Control
TSN	Transmission Sequence Number
U-	User-
UE	User Equipment
UL	Uplink
UMTS	Universal Mobile Telecommunications System
URA	UTRAN Registration Area
UTRA	UMTS Terrestrial Radio Access
UTRAN	UMTS Terrestrial Radio Access Network

4 Interfaces to the physical layer

The physical layer (layer 1) is the lowest layer in the OSI Reference Model and it supports all functions required for the transmission of bit streams on the physical medium.

The physical layer interfaces the Medium Access Control (MAC) Layer and the Radio Resource Control (RRC) Layer as depicted in figure 1.

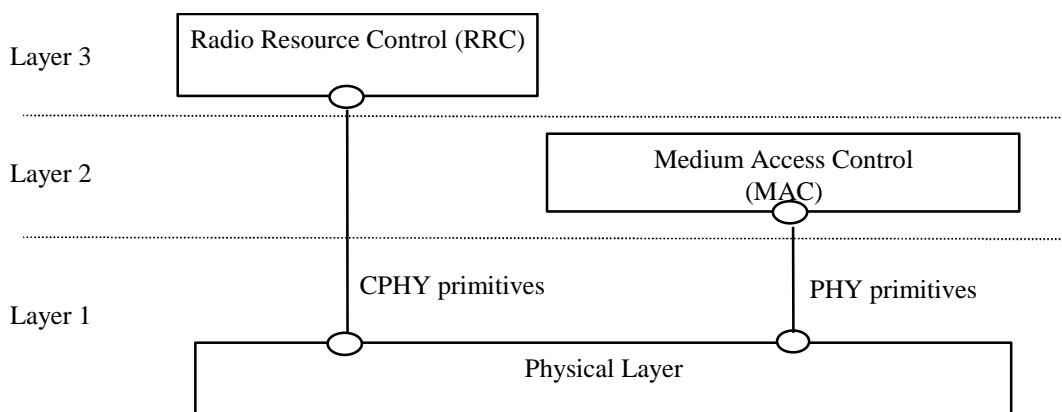

Figure 1: Interfaces with the Physical Layer

4.1 Interface to MAC

The physical layer interfaces the MAC entity of layer 2. Communication between the Physical Layer and MAC is in an abstract way performed by means of PHY-primitives defined which do not constrain implementations.

NOTE: The terms physical layer and layer 1, will be used synonymously in this description.

The PHY-primitives exchanged between the physical layer and the data link layer provide the following functions:

- transfer of transport blocks over the radio interface;
- indicate the status of the layer 1 to layer 2.

4.2 Interface to RRC

The physical layer interfaces the RRC entity of layer 3 in the UE and in the network.

Communication is performed in an abstract way by means of CPHY-primitives. They do not constrain implementations.

The CPHY-primitives exchanged between the physical layer and the Network layer provide the following function:

- control of the configuration of the physical layer.

The currently identified exchange of information across that interface has only a local significance to the UE or Network.

5 Services and functions of the physical layer

5.1 General

The physical layer offers data transport services to higher layers. The access to these services is through the use of transport channels via the MAC sub-layer. The characteristics of a transport channel are defined by its transport format (or format set), specifying the physical layer processing to be applied to the transport channel in question, such as convolutional channel coding and interleaving, and any service-specific rate matching as needed.

The physical layer operates exactly according to the L1 radio frame timing. A transport block is defined as the data accepted by the physical layer to be jointly CRC protected. The transmission block timing is then tied exactly to the TTI timing, e.g. every transmission block is generated precisely every TTI.

A UE can set up multiple transport channels simultaneously, each having own transport characteristics (e.g. offering different error correction capability). Each transport channel can be used for information stream transfer of one radio bearer or for layer 2 and higher layer signalling messages.

The multiplexing of transport channels onto the same or different physical channels is carried out by L1. Except for HS-DSCH and E-DCH the Transport Format Combination Indication field (TFCI) shall uniquely identify the transport format used by each transport channel of the Coded Composite Transport Channel within the current radio frame.

In case of HS-DSCH the identification of the transport format and channelisation codes is realised with the Transport Format and Resource Indication field (TFRI) on an associated shared control channel.

In case of FDD E-DCH the identification of the transport format is realised with the E-DCH Transport Format Combination Indication field (E-TFCI) on an associated dedicated control channel.

In the case of TDD E-DCH the identification of the transport format is realised with the E-DCH Transport Format Combination Indication field (E-TFCI) multiplexed onto E-PUCH.

5.2 Overview of L1 functions

The physical layer performs the following main functions:

- FEC encoding/decoding of transport channels;
- measurements and indication to higher layers (e.g. FER, SIR, interference power, transmission power, etc...);
- macrodiversity distribution/combining and soft handover execution;
- error detection on transport channels;
- multiplexing of transport channels and demultiplexing of coded composite transport channels;
- rate matching;
- mapping of coded composite transport channels on physical channels;
- modulation and spreading/demodulation and despreading of physical channels;
- frequency and time (chip, bit, slot, frame) synchronisation;
- closed-loop power control;
- power weighting and combining of physical channels;
- RF processing;
- support of Uplink Synchronisation as defined in [5] (TDD only);
- timing advance on uplink channels (TDD only).

5.3 L1 interactions with L2 retransmission functionality

Provided that the RLC PDUs are mapped one-to-one onto the Transport Blocks, Error indication may be provided by L1 to L2. For that purpose, the L1 CRC can be used for individual error indication of each RLC PDU.

The L1 CRC may serve multiple purposes:

- error indication for uplink macro diversity selection combining (L1);
- error indication for each erroneous Transport Block in transparent and unacknowledged mode RLC;
- quality indication;
- error indication for each erroneous Transport Block in acknowledged mode RLC.

Regardless of the result of the CRC check, all Transport Blocks are delivered to L2 along with the associated error indications for transport channel other than HS-DSCH and E-DCH. In case of HS-DSCH and E-DCH an error indication is provided to L2 in case of CRC failure.

In case of HS-DSCH and E-DCH retransmissions of Transport Blocks may be requested before transport blocks are delivered to L2.

6 Model of physical layer of the UE

6.1 Uplink models

Figure 2 shows models of the UE's physical layer in the uplink for both FDD and TDD mode. It shows the models for DCH, RACH, E-DCH, and USCH (TDD only). Some restriction exist for the use of different types of transport channel at the same time, these restrictions are described in the clause "UE Simultaneous Physical Channel combinations". More details can be found in [3] and [4].

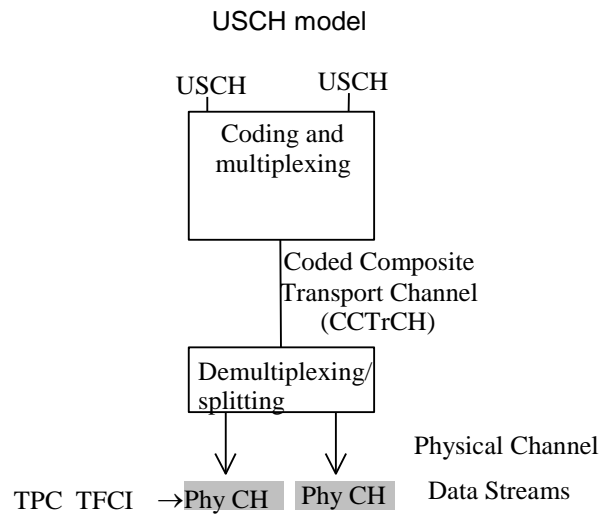
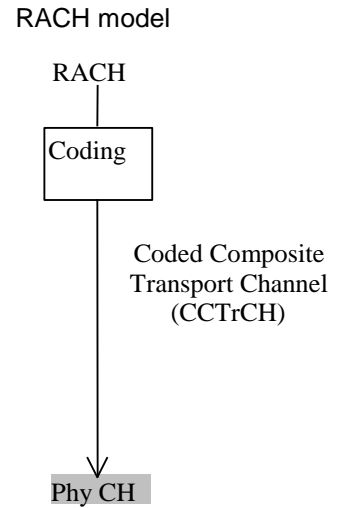
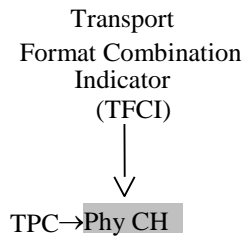
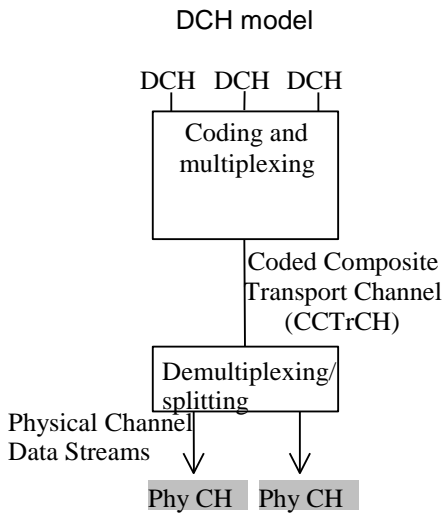

DCH model with HS-DSCH support

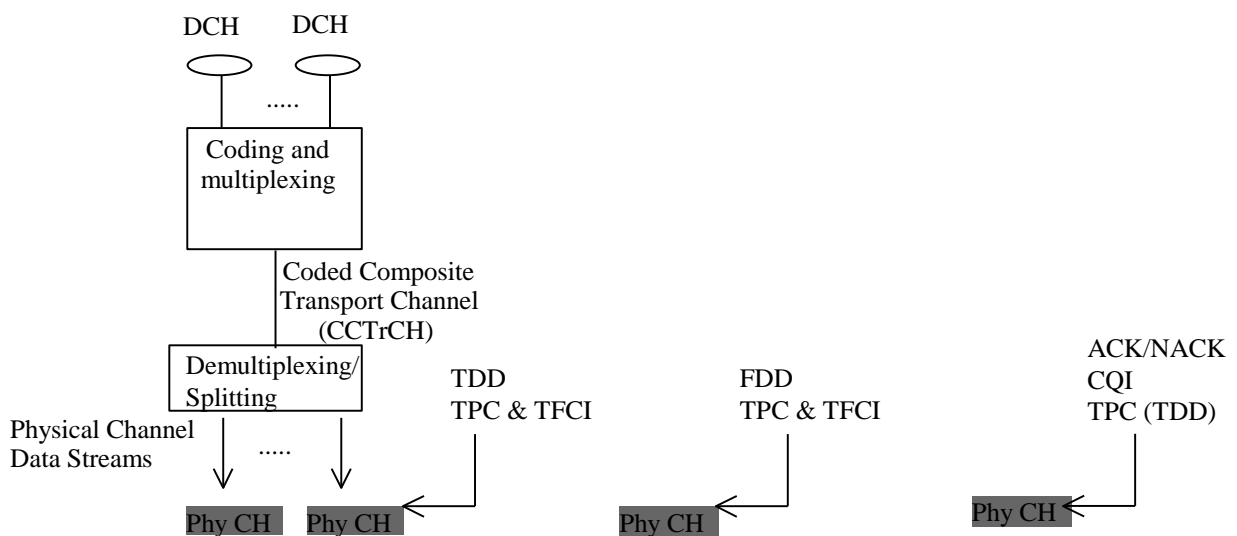

DCH and E-DCH model with HS-DSCH support

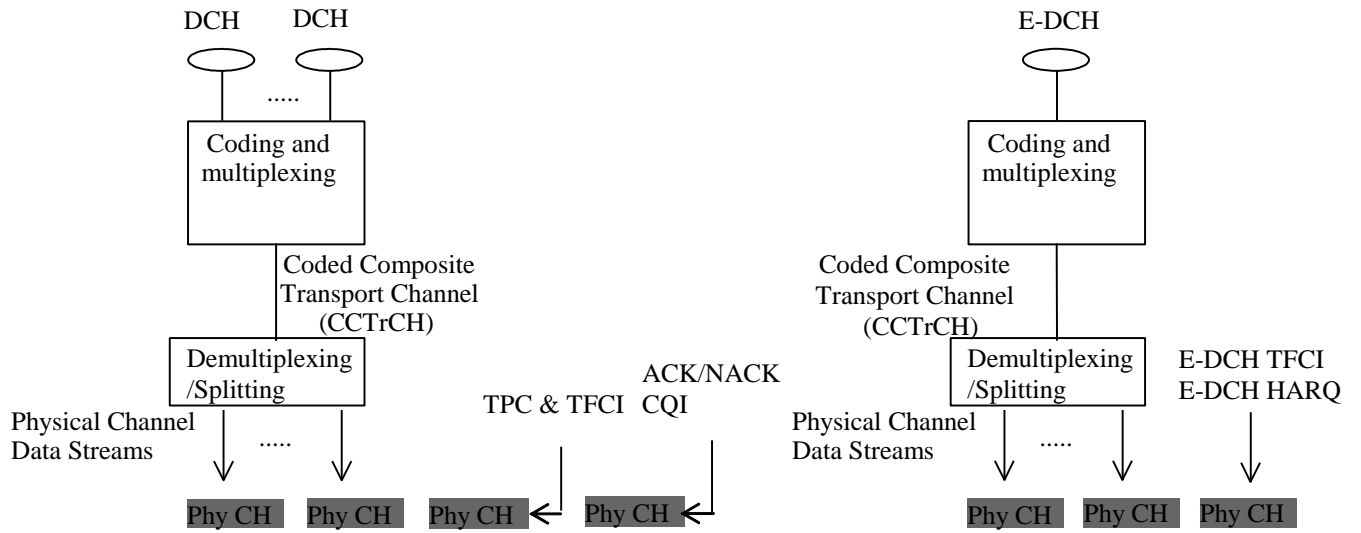

E-DCH with HS-DSCH (no DCH)

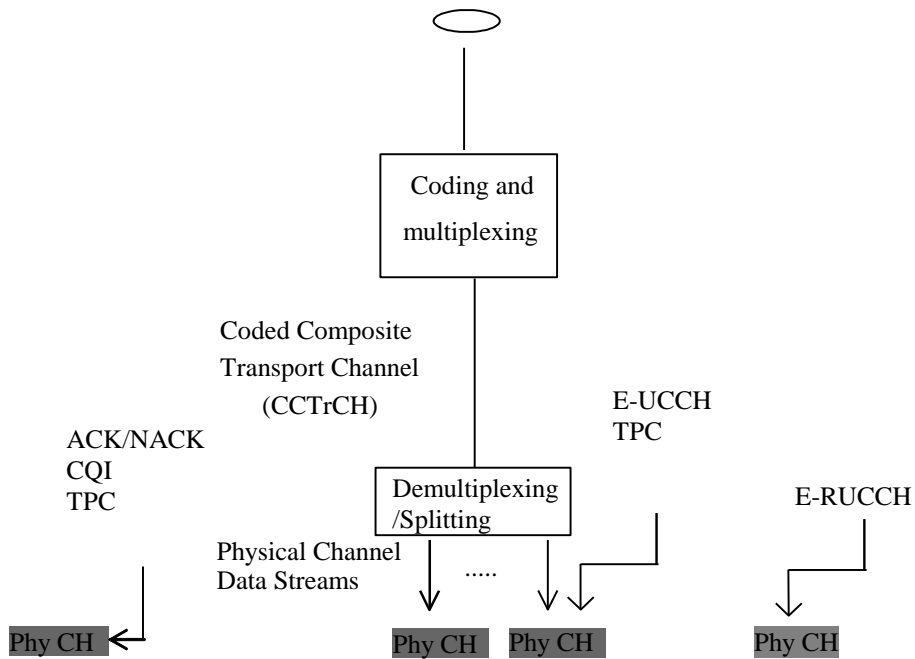

E-DCH with DCH and HS-DSCH

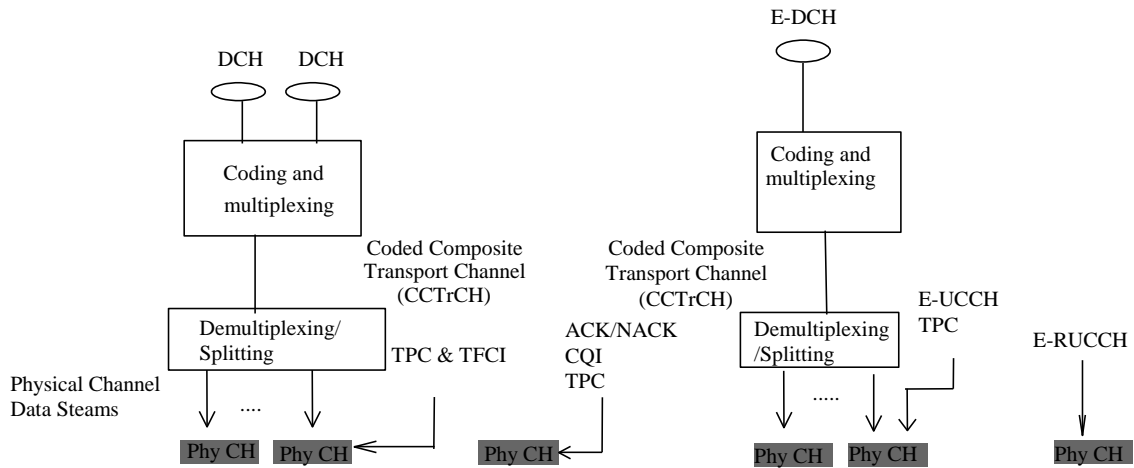

E-DCH model with HS-DSCH(1.28 Mcps TDD multi-carrier E-DCH operation mode only)

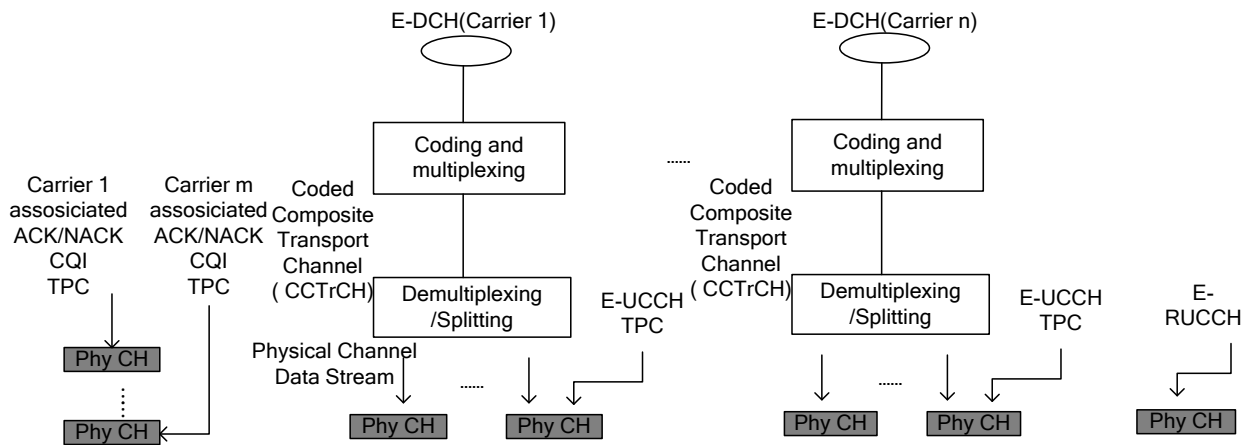

E-DCH model with DCH(1.28 Mcps TDD multi-carrier E-DCH operation mode only)

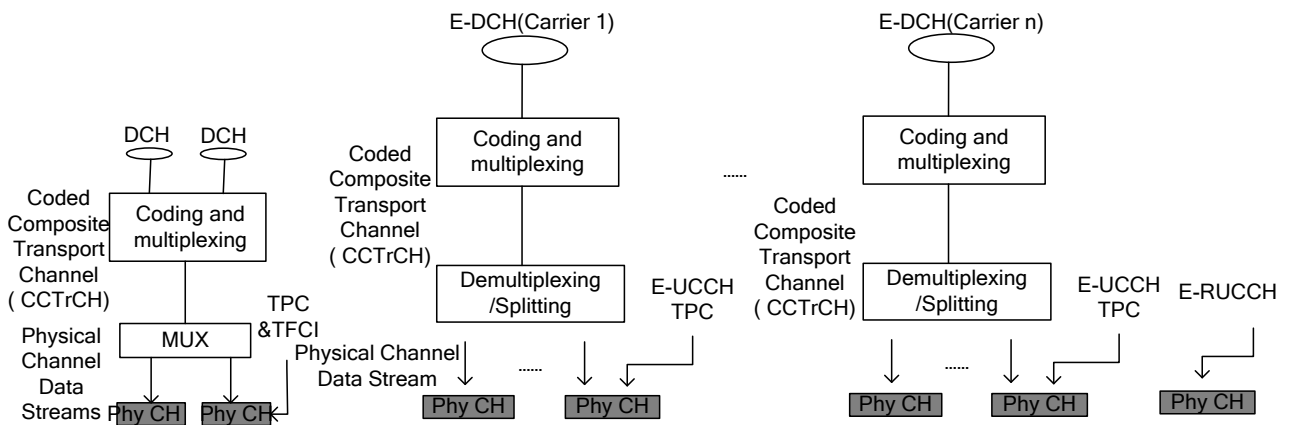

E-DCH model with DCH and HS-DSCH(1.28 Mcps TDD multi-carrier E-DCH operation mode only)

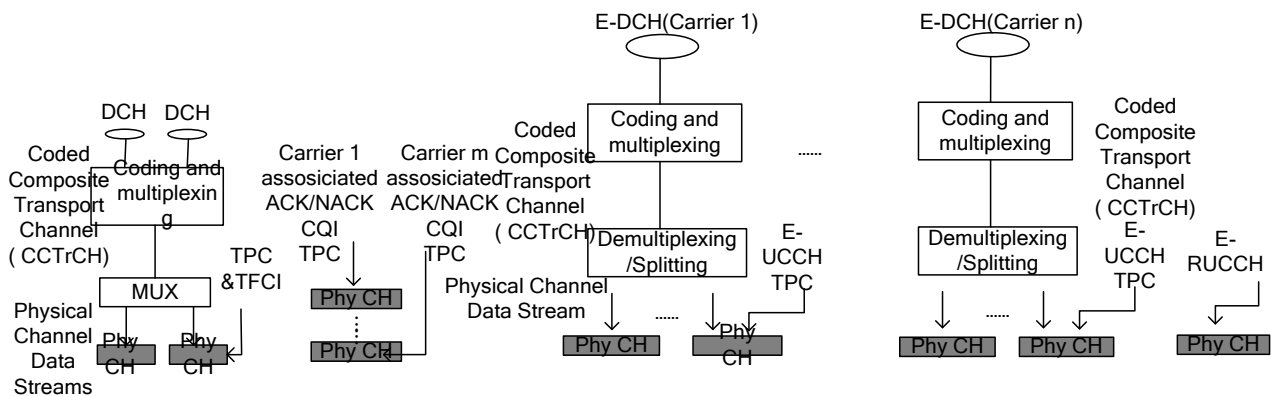

NOTE 1: USCH is for TDD only.

Figure 2: Model of the UE's physical layer – uplink

The DCH model shows that one or several DCHs can be processed and multiplexed together by the same coding and multiplexing unit. The detailed functions of the coding and multiplexing unit are not defined in the present document but in [3] and [4]. The single output data stream from the coding and multiplexing unit is denoted *Coded Composite Transport Channel (CCTrCH)*.

The bits on a CCTrCH Data Stream can be mapped on the same Physical Channel and should have the same C/I requirement.

On the downlink, multiple CCTrCH can be used simultaneously with one UE. In the case of FDD, only one fast power control loop is necessary for these different CCTrCH, but the different CCTrCH can have different C/I requirements to provide different QoS on the mapped Transport Channels. In the case of TDD, different power control loops can be applied for different CCTrCH. One physical channel can only have bits coming from the same CCTrCH.

On the uplink and in the case of FDD, when E-DCH is not configured, only one CCTrCH can be used simultaneously. On the uplink and in the case of TDD, multiple CCTrCH can be used simultaneously.

On the uplink and in case of FDD, two CCTrCHs are used simultaneously when the E-DCH Transport Channel is configured.

When multiple CCTrCH are used by one UE, one or several TFCI can be used, but each CCTrCH has only zero or one corresponding TFCI. In the case of FDD, these different words are mapped on the same DPCCCH. In the case of TDD, these different TFCIs can be mapped on different DPCH.

The data stream of the CCTrCH is fed to a data demultiplexing/splitting unit that demultiplexes/splits the CCTrCH's data stream onto one or several *Physical Channel Data Streams*.

The current configuration of the coding and multiplexing unit is either signalled to, or optionally blindly detected by, the network for each 10 ms frame. If the configuration is signalled, it is represented by the *Transport Format Combination Indicator (TFCI)* bits. Note that the TFCI signalling only consists of pointing out the current transport format combination within the already configured transport format combination set. In the uplink there is only one TFCI representing the current transport formats on all DCHs of one CCTrCH simultaneously. In FDD mode, the physical channel data stream carrying the TFCI is mapped onto the physical channel carrying the power control bits and the pilot. In TDD mode the TFCI is time multiplexed onto the same physical channel(s) as the DCHs. The exact locations and coding of the TFCI are signalled by higher layers.

The DCH and USCH have the possibility to perform Timing Advance in TDD mode.

The model for the RACH case shows that RACH is a common type transport channel in the uplink. RACHs are always mapped one-to-one onto physical channels (PRACHs), i.e. there is no physical layer multiplexing of RACHs, and there can only be one RACH TrCH and no other TrCH in a RACH CCTrCH. Service multiplexing is handled by the MAC layer. In one cell several RACHs/PRACHs may be configured. If more than one PRACH is configured in a cell, the UE performs PRACH selection as specified in [4].

In FDD, the RACHs mapped to the PRACHs may all employ the same Transport Format and Transport Format Combination Sets, respectively. It is however also possible that individual RACH Transport Format Sets are applied on each available RACH/PRACH.

In TDD, there is no TFCI transmitted in the burst, and therefore each RACH is configured with a single transport format within its TFS. The RACHs mapped to the PRACHs may all employ the same Transport Format. It is however also possible that individual RACH Transport Formats are applied on each available RACH/PRACH combination.

The available pairs of RACH and PRACHs and their parameters are indicated in system information. In FDD mode, the various PRACHs are distinguished either by employing different preamble scrambling codes, or by using a common scrambling code but distinct (non-overlapping) partitions of available signatures and available subchannels. In TDD mode, the various PRACHs are distinguished either by employing different timeslots, or by using a common timeslot but distinct (non-overlapping) partitions of available channelisation codes and available subchannels. Examples of RACH/PRACH configurations are given in [6].

In FDD in case of a configured HS-DSCH in CELL_DCH state, one physical channel (HS-DPCCH) is configured for the reporting of HS-DSCH transport block acknowledgement / negative acknowledgement and channel quality indicator. The HS-DPCCH is only configured on the primary uplink frequency. When MIMO mode is configured, the HS-DPCCH also carries precoding control information. In FDD, when more than three secondary cells are configured, two HS-DPCCHs are configured to carry feedback information related to the HS-DSCH transport channels.

In FDD in case of a configured Multiflow in CELL_DCH state, one physical channel (HS-DPCCH) is configured for reporting of HS-DSCH transport block acknowledgement / negative acknowledgement and channel quality indicators from the serving and assisting HS-DSCH cells. The HS-DPCCH is only configured on the primary uplink frequency. When MIMO mode is configured, the HS-DPCCH also carries precoding control information.

In TDD in case of a configured HS-DSCH a shared physical channel (HS-SICH) is configured for the reporting of HS-DSCH transport block acknowledgement / negative acknowledgement, channel quality indicator and transmit power control symbols.

In FDD in case of a configured HS-DSCH reception in CELL_FACH, CELL_PCH or URA_PCH states there is neither acknowledgement / negative acknowledgement nor channel quality indicator. Therefore, no physical channel (HS-DPCCH) is configured.

If the E-DCH is applicable, there can only be one E-DCH TrCH and no other TrCH in an E-DCH CCTrCH per activated uplink frequency. For FDD, the E-DCH CCTrCH is carried on E-DPDCH(s) physical channel(s). E-DCH TFCI and E-DCH HARQ information are carried on an E-DPCCH physical channel. For FDD, a single bit is transmitted on the E-DPCCH physical channel per activated uplink frequency to indicate whether the UE could use more resources or not. For TDD, the E-DCH is carried on the E-PUCH physical channel(s). The E-PUCH also carries E-UCCH (E-DCH TFCI and E-DCH HARQ information).

In FDD mode and CELL_DCH state when Dual Cell E-DCH operation is configured, one E-DCH transport channel is transmitted on each activated uplink frequency. Each E-DCH transport channel has its own associated uplink signalling.

In FDD mode and CELL_DCH state when uplink CLTD is configured, two dedicated pilot channels, DPCCH and S-DPCCH, are transmitted in the uplink.

In FDD mode and CELL_DCH state, when uplink MIMO is configured and the CLTD activation state is 1 [8], two dedicated pilot channel, DPCCH and S-DPCCH, are transmitted in the uplink. Two transport blocks may be transmitted in parallel: a primary transport block on the primary precoding vector using E-DPDCH physical channels, and a secondary transport block on the secondary precoding vector using S-E-DPDCH physical channels. When the secondary transport block is present, then S-E-DPCCH is transmitted on the primary precoding vector providing the E-TFCI and E-DCH HARQ information for the secondary transport block.

6.2 Downlink models

Figure 3 and figure 4 show the model of the UE's physical layer for the downlink in FDD and TDD mode, respectively. Note that there is a different model for each transport channel type.

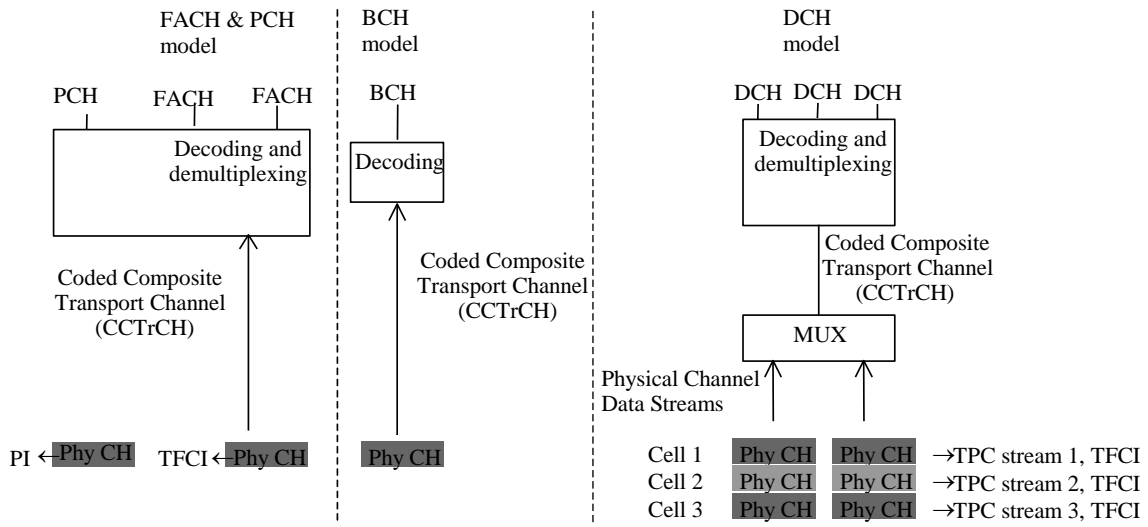

HS-DSCH(s) model in CELL_FACH, CELL_PCH and URA_PCH states
 PI only used in CELL_PCH and URA_PCH states

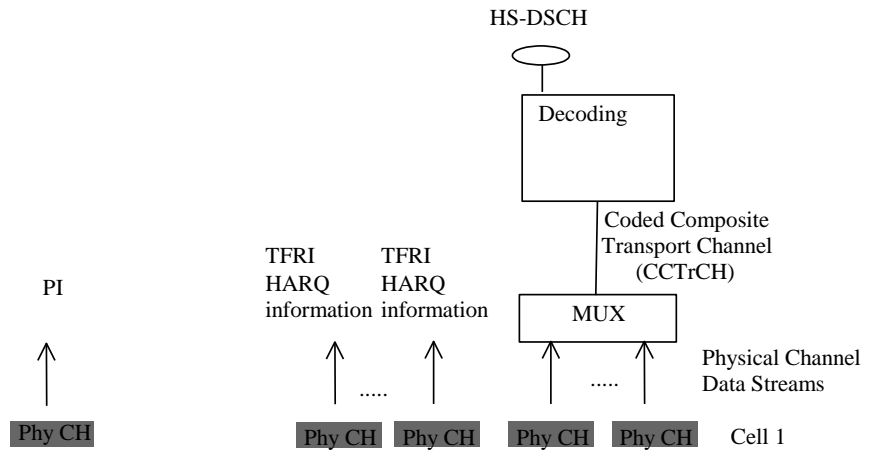

DCH model with HS-DSCH(s)

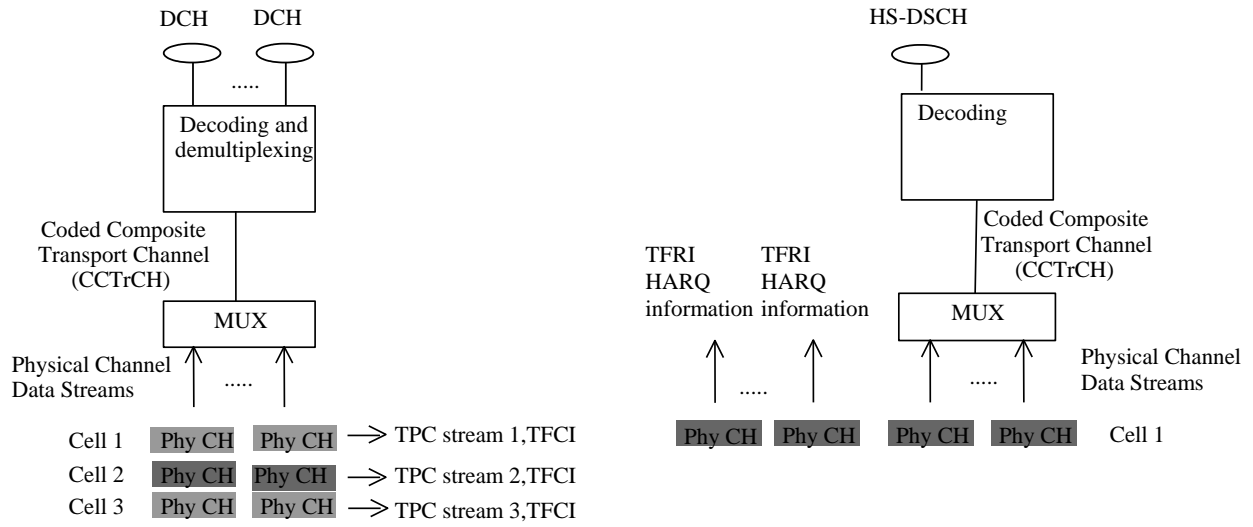

DCH and HS-DSCH model with E-DCH support

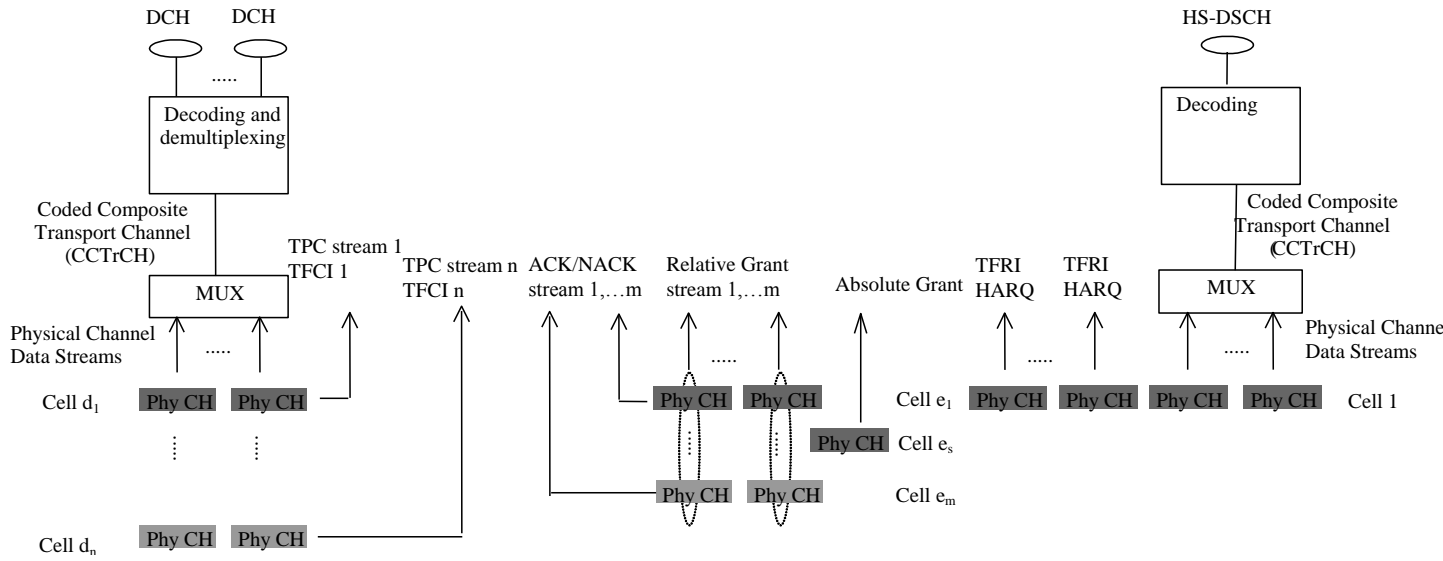

HS-DSCH(s) with F-DPCH model

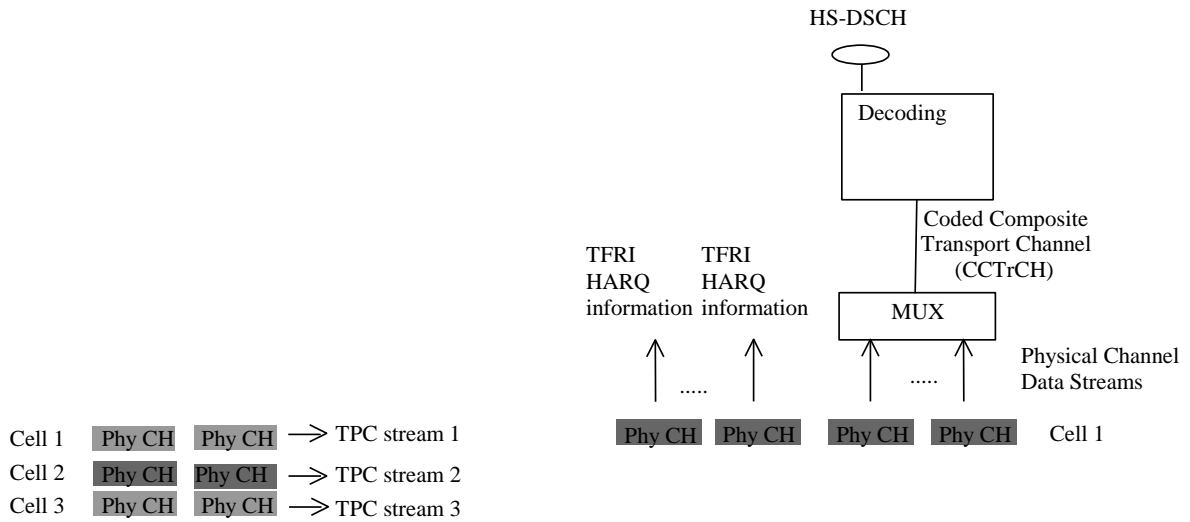

HS-DSCH with F-DPCH model and E-DCH support

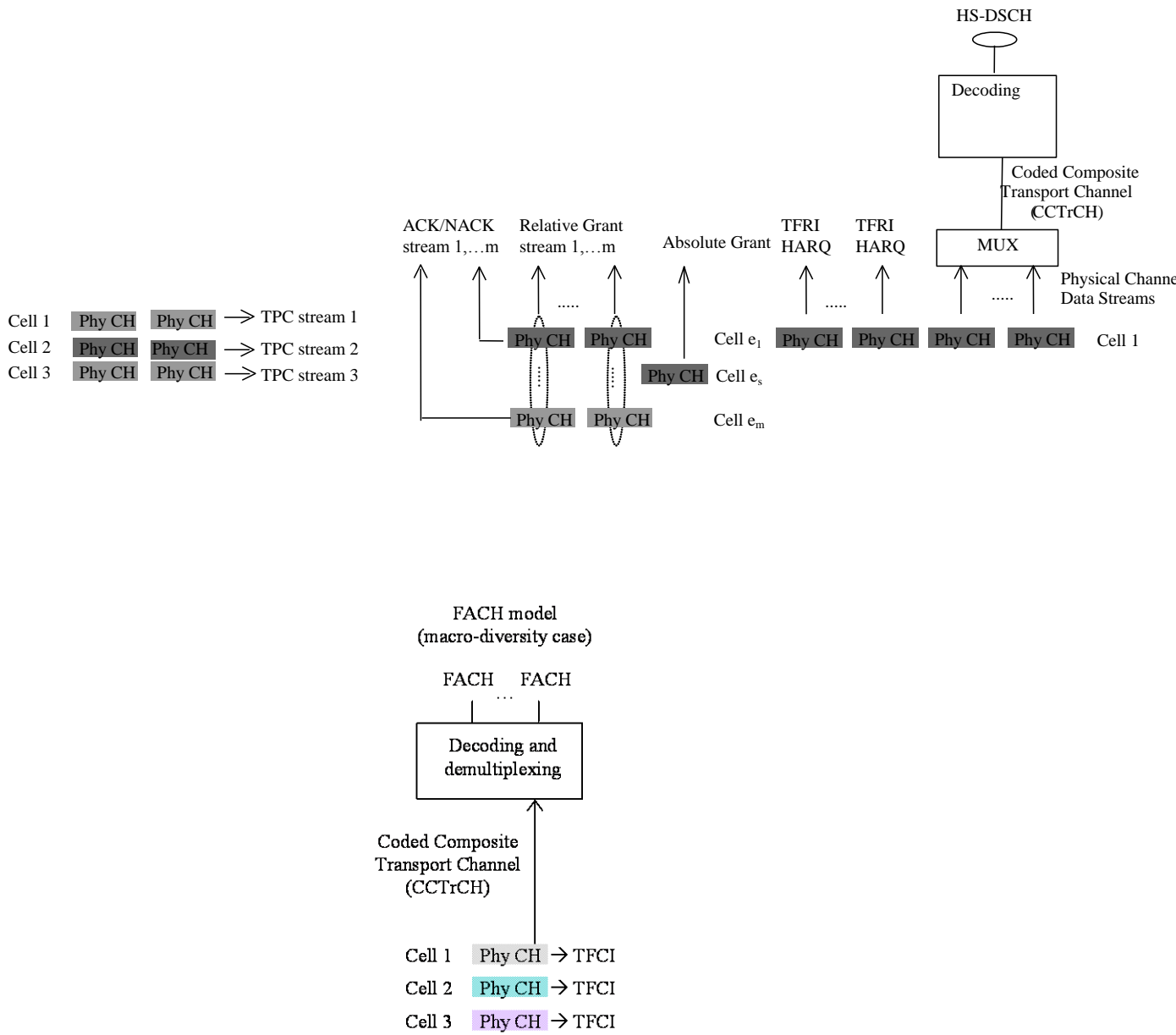
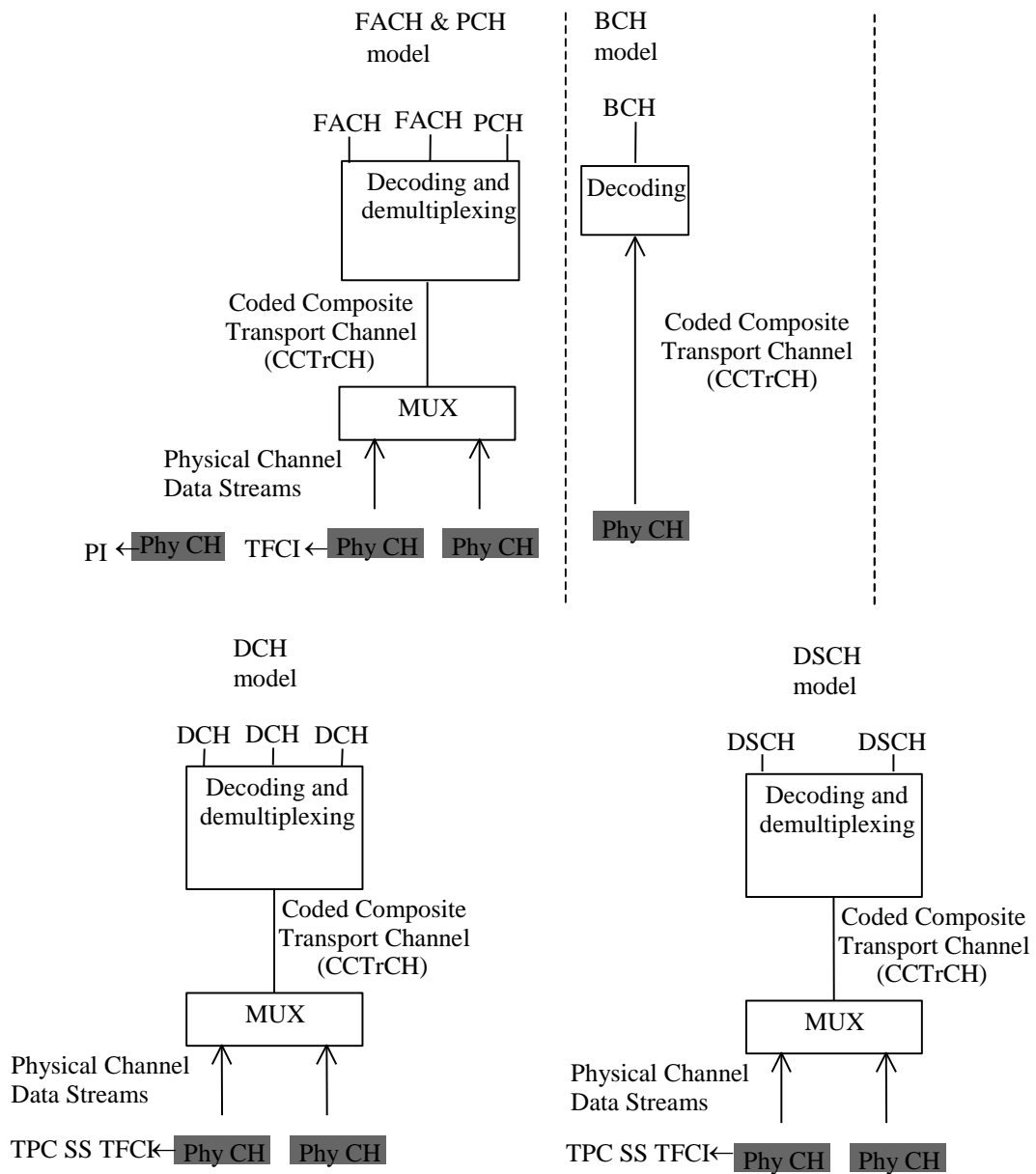
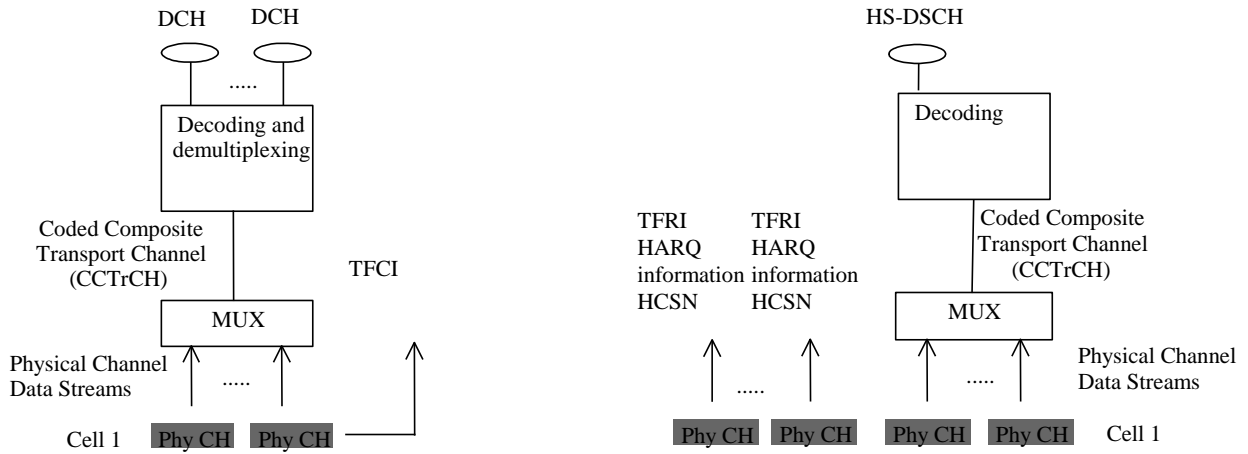

Figure 3: Model of the UE's physical layer - downlink FDD mode



HS-DSCH(s) for 3.84 and 7.68 Mcps TDD with DL DPCH



HS-DSCH(s) for 3.84 and 7.68 Mcps TDD without DL DPCH

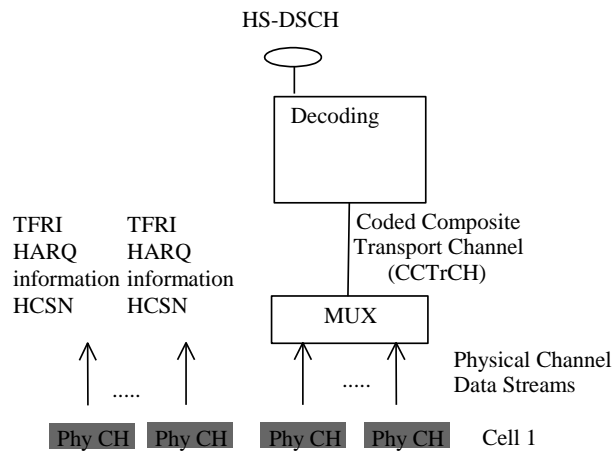

HS-DSCH(s) with DL DPCH for 1.28 Mcps TDD

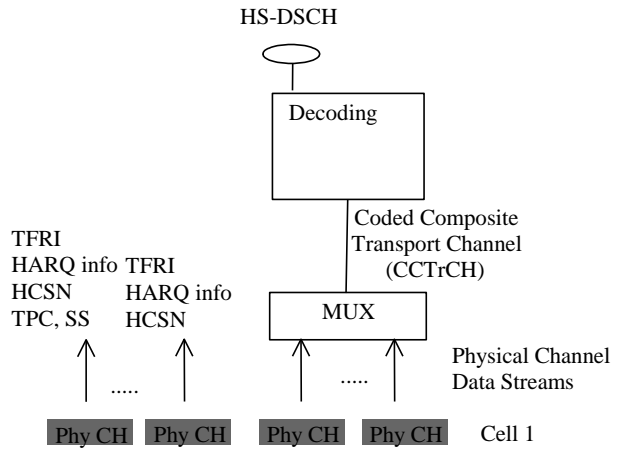
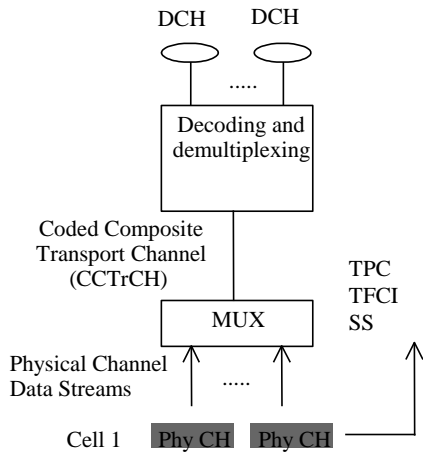

HS-DSCH(s) without DL DPCH for 1.28 Mcps TDD

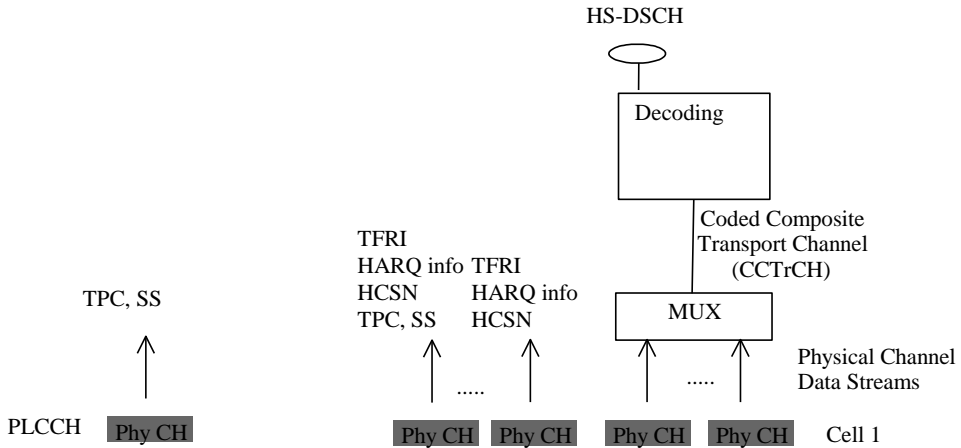

E-DCH model with HS-DSCH (no DCH) (3.84 Mcps and 7.68 Mcps TDD)

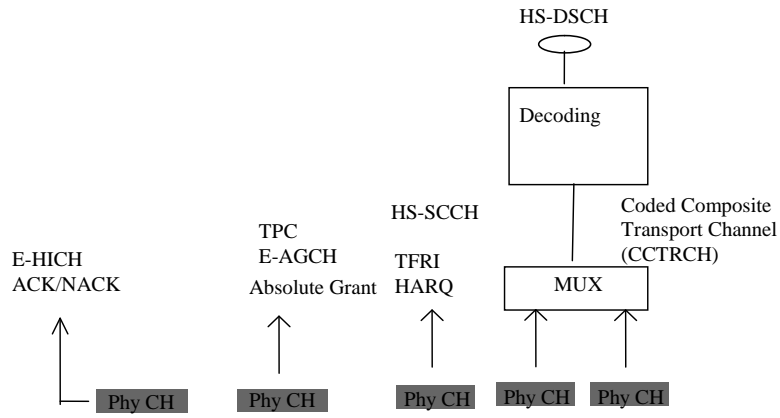

E-DCH with DCH and HS-DSCH (3.84 Mcps and 7.68 Mcps TDD)

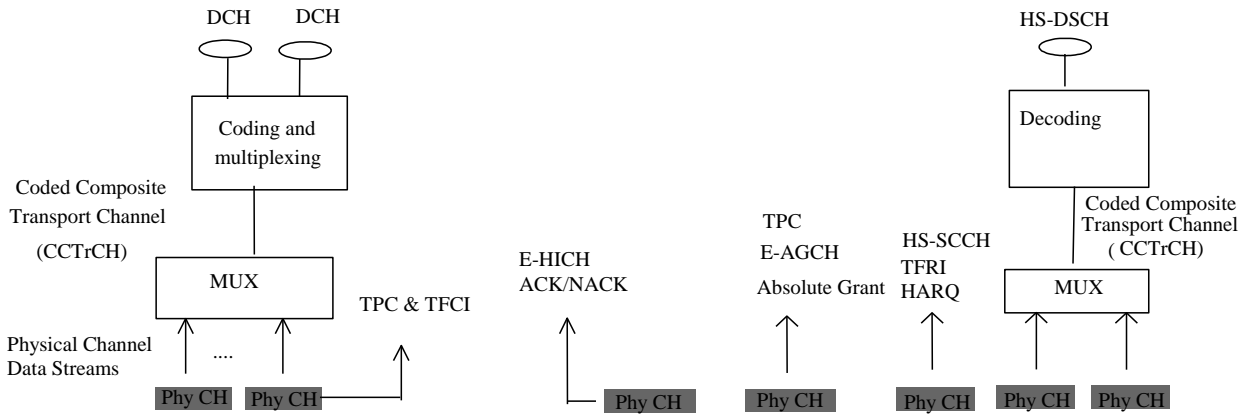

E-DCH model with HS-DSCH (no DCH) (1.28 Mcps TDD)

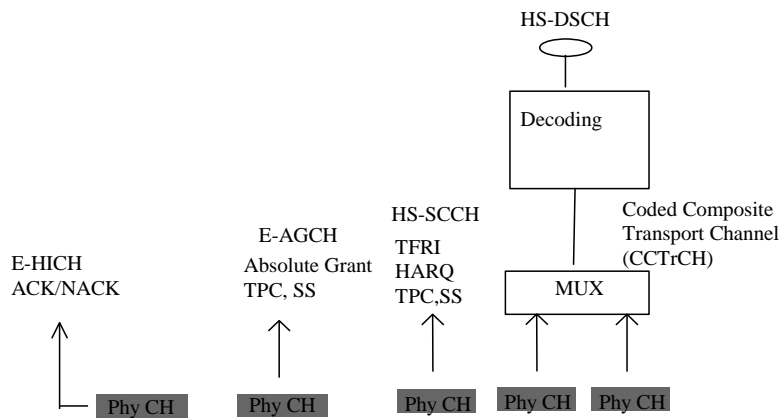

E-DCH with DCH and HS-DSCH (1.28 Mcps TDD)

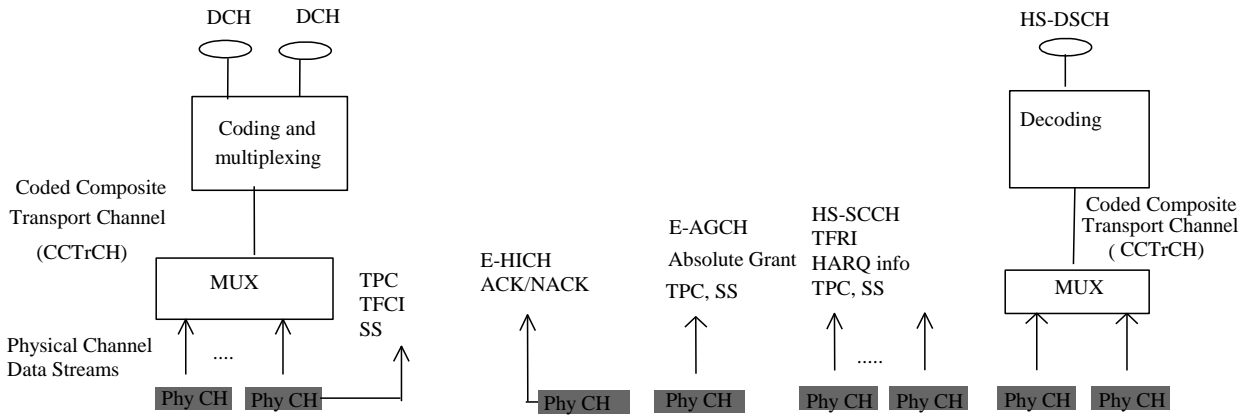

FACH model
(transport channel combining case)

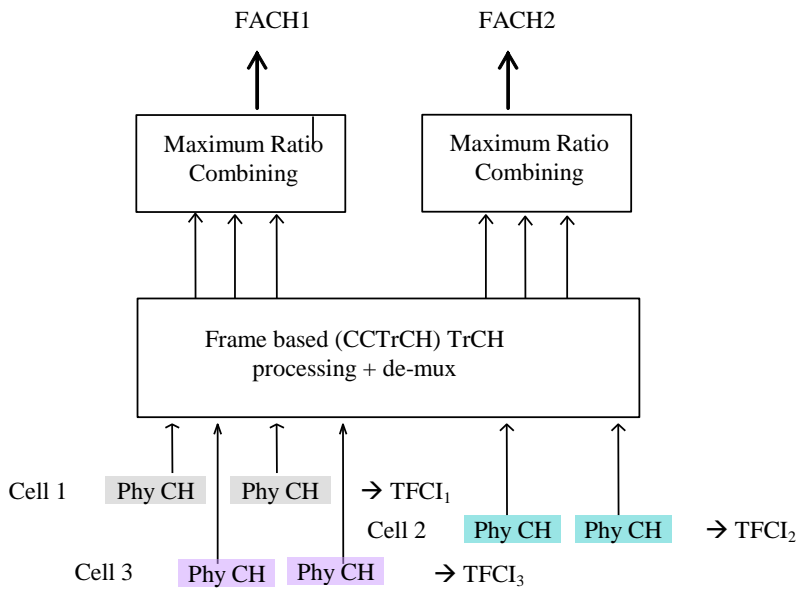

E-DCH with HS-DSCH in CELL_FACH (1.28 Mcps TDD)

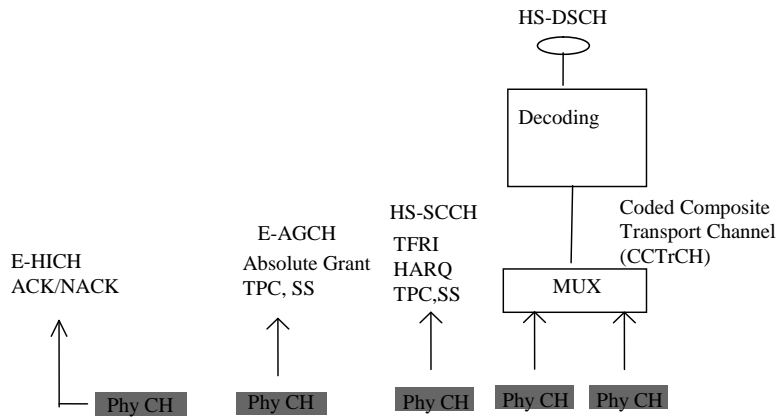

HS-DSCH in CELL_PCH and URA_PCH (1.28 Mcps TDD)

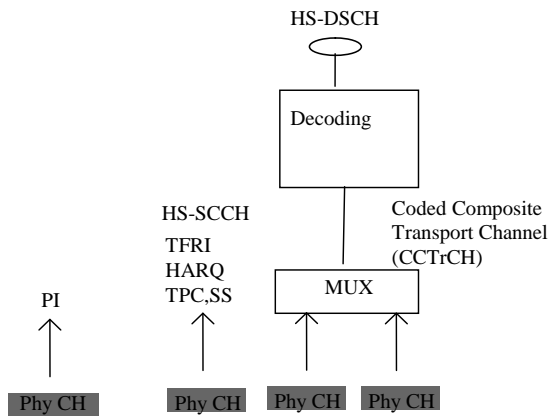

E-DCH model with HS-DSCH [1.28 Mcps TDD multi-carrier E-DCH operation mode only]

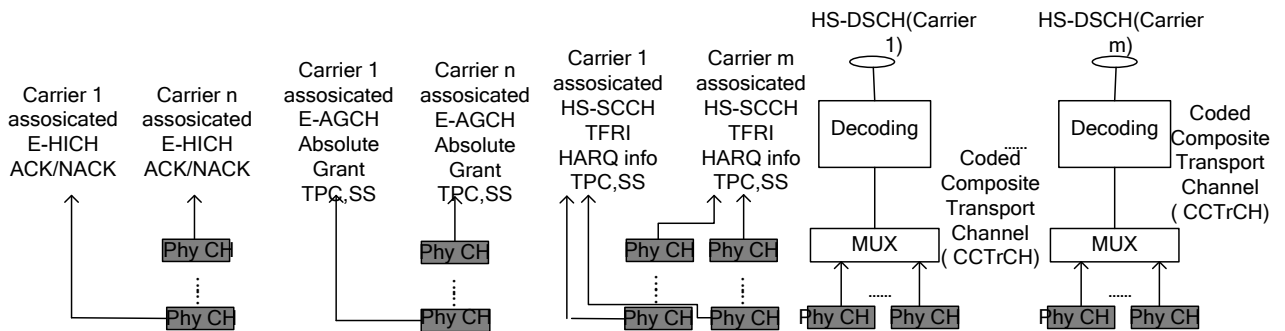

E-DCH model with DCH | 1.28 Mcps TDD multi-carrier E-DCH operation mode only|

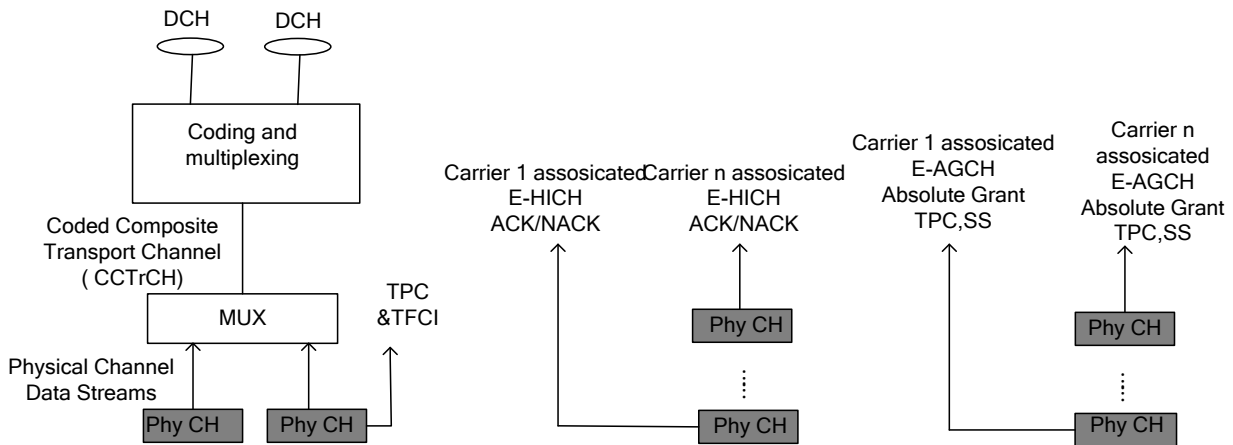

E-DCH model with DCH and HS-DSCH | 1.28 Mcps TDD multi-carrier E-DCH operation mode only|

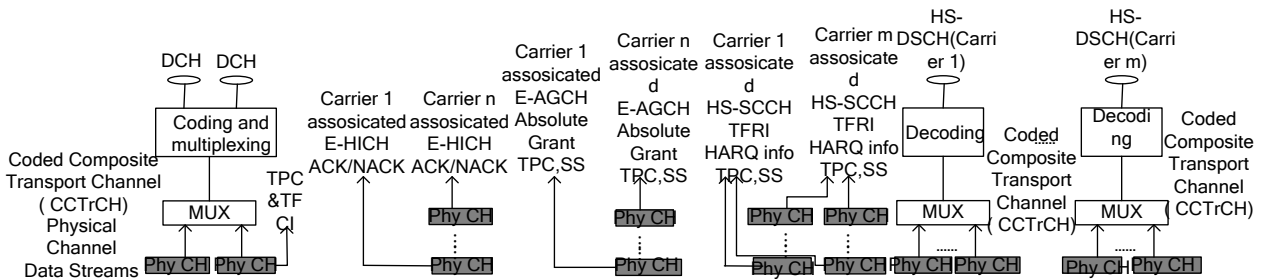

Figure 4: Model of the UE's physical layer - downlink TDD mode

For the DCH case, the mapping between DCHs and physical channel data streams works in the same way as for the uplink. Note however, that the number of DCHs, the coding and multiplexing etc. may be different in uplink and downlink.

In the FDD mode, the differences are mainly due to the soft and softer handover. Further, the pilot, TPC bits and TFCI are time multiplexed onto the same physical channel(s) as the DCHs, in case of HS-DSCH(s) without a DCH in the DL. TPC bits are carried onto F-DPCH(s). Further, the definition of physical channel data stream is somewhat different from the uplink. In TDD mode the TFCI is time multiplexed onto the same physical channel(s) as the DCHs. The exact locations and coding of the TFCI are signalled by higher layers.

Note that it is logically one and the same physical data stream in the active set of cells, even though physically there is one stream for each cell. The same processing and multiplexing is done in each cell. The only difference between the cells is the actual codes, and these codes correspond to the same spreading factor.

The physical channels carrying the same physical channel data stream are combined in the UE receiver, excluding the pilot, and in some cases the TPC bits. TPC bits received on certain physical channels may be combined provided that UTRAN has informed the UE that the TPC information on these channels is identical.

A PCH and one or several FACH can be encoded and multiplexed together forming a CCTrCH. Similarly as in the DCH model there is one TFCI for each CCTrCH for indication of the transport formats used on each PCH and FACH. The PCH is associated with a separate physical channel carrying page indicators (PIs) which are used to trigger UE reception of the physical channel that carries PCH. A FACH or a PCH can also be individually mapped onto a separate physical channel. The BCH is always mapped onto one physical channel without any multiplexing with other transport channels, and there can only be one BCH TrCH and no other TrCH in a BCH CCTrCH.

For point-to-multipoint transmission [14], FACH can be distributed on a set of physical layer combinable CCTrCHs, i.e., for macro-diversity combining: soft combining (FDD and TDD) or transport channel combining (TDD only). The physical layer combinable CCTrCHs shall have the same TFC during the TTIs in which soft combining can be used. The physical layer combinable CCTrCHs need not have the same TFC during the TTIs in which transport channel

combining can be used. The possibility of performing macro-diversity combining (either soft combining or transport channel combining) shall be signalled to the UE.

In the TDD mode a CCTrCh carrying PCH and one or several FACH can be multiplexed onto one or several physical channel data streams.

For each HS-DSCH TTI, each HS-SCCH carries HS-DSCH-related downlink signalling for one UE when in CELL_DCH state, or in FDD and 1.28Mcps TDD mode for one UE or multiple UEs in CELL_FACH, CELL_PCH or URA_PCH state. The following information is carried on the HS-SCCH:

- Transport Format and Resource Indicator (TFRI);
- Hybrid-ARQ-related Information (HARQ information);
- UE Identity via a UE specific CRC;
- HS-SCCH Cyclic Sequence Number (HCSN) for TDD.

In addition, for the case of 1.28 Mcps TDD, the HS-SCCH also carries Transmit Power Control and Synchronisation Shift symbols.

In FDD mode and CELL_DCH state when MIMO mode is configured, single stream and dual stream transmission of HS-DSCH can be performed for each HS-DSCH TTI in the Serving HS-DSCH cell. In case of dual stream transmission two HS-DSCHs are transmitted to UE and the HS-SCCH includes information for both HS-DSCHs. When UE is configured into Dual Cell HSDPA operation, one HS-DSCH transport channel is transmitted on each configured downlink frequency. Each of these HS-DSCH transport channels has its own associated uplink and downlink signalling, and own HARQ entity. When UE is configured into Dual Band HSDPA operation, single stream transmission of HS-DSCH is performed for each HS-DSCH TTI on each configured downlink frequency. When UE is configured to operate in Dual Cell HSDPA and MIMO mode, either or both of the HS-DSCH serving cells can be configured with MIMO operation, i.e. depending on the configuration up to four HS-DSCHs can be transmitted to UE per HS-DSCH TTI. When UE is configured into Four Carrier HSDPA operation, there is one Serving HS-DSCH cell and up to three Secondary serving HS-DSCH cells. When UE is configured into Eight Carrier HSDPA operation, there is one Serving HS-DSCH cell and up to seven Secondary serving HS-DSCH cells. When MIMO is not configured on any of the serving or secondary serving HS-DSCH cells, one HS-DSCH transport channel is transmitted on each configured serving and secondary serving HS-DSCH cells, and each of these HS-DSCH transport channels has its own associated uplink and downlink signalling, and own HARQ entity. Further, a UE may be configured into Four Carrier HSDPA or Eight Carrier HSDPA operation operation with MIMO mode on any of the serving or secondary serving HS-DSCH cells. Depending on the MIMO configuration up to sixteen HS-DSCHs can be transmitted to UE per HS-DSCH TTI.

In FDD mode and CELL_DCH state when MIMO mode with four transmit antennas is configured, single stream, dual stream, three streams and four streams transmissions of HS-DSCH can be performed for each HS-DSCH TTI in the Serving HS-DSCH cell and the Secondary serving HS-DSCH cells. In case of dual/three/four stream transmission the respective number of HS-DSCH transport blocks are transmitted to the UE and the HS-SCCH includes information for the transmitted HS-DSCH transport blocks. When UE is configured to operate in Dual Cell HSDPA and MIMO mode with four transmit antennas, either or both of the Serving HS-DSCH cells can be configured in MIMO mode with four transmit antennas. Further, a UE may be configured with Four Carrier HSDPA operation in MIMO mode with four transmit antennas on any of the serving or Secondary serving HS-DSCH cells. Depending on the MIMO mode with four transmit antennas configuration up to sixteen HS-DSCH transport blocks can be transmitted to UE per HS-DSCH TTI.

In FDD mode and CELL_DCH state when Multiflow is configured, two HS-DSCH cells can be configured on the same frequency. The HS-DSCH cells can belong either to the same Node B (intra-Node B configuration), or two different Node Bs (inter-Node B configuration). The Multiflow assisting serving cell on the primary frequency must be part of the UE active set. Each HS-DSCH transport channel has its own associated uplink and downlink signalling, and own HARQ entity. When a UE is configured to operate in Multiflow and MIMO mode, each HS-DSCH serving and assisting cell can be configured independently with MIMO operation. When MIMO mode is configured, single stream and dual stream transmission of HS-DSCH can be performed for each HS-DSCH TTI in the serving, or assisting serving, or (assisting) secondary serving HS-DSCH cell.

In TDD mode, HS-DSCH operation is supported without an associated DL DPCH.

In FDD mode, if the UE is in CELL_DCH state, the E-DCH active set can be identical or a subset of the DCH active set. If the UE is in CELL_FACH state or Idle mode, the UE's E-DCH active set consists of a single serving cell. If Dual Cell E-DCH operation is configured in CELL_DCH state, DCH is not supported in uplink and downlink. The active set

and E-DCH active set on both uplink frequencies are independent, but the Serving E-DCH cells in both E-DCH active sets belong to the same Node B. On secondary uplink frequency the active set and E-DCH active set have the same size.

For FDD: The E-DCH ACK/NACKs are transmitted by each cell of the E-DCH active set on a physical channel called E-HICH. The E-HICHs of the cells belonging to the same RLS (same MAC-e entity i.e. same Node B) shall have the same content and be combined by the UE. The set of cells transmitting identical ACK/NACK information is the same as the set of cells sending identical TPC bits (excluding the cells which are not in the E-DCH active set).

For 3.84 Mcps and 7.68 Mcps TDD: The E-DCH ACK/NACKs are transmitted via the current serving cell on a physical channel called the E-HICH.

For 1.28 Mcps TDD: For each uplink frequency, an E-DCH ACK/NACK is transmitted via the current serving cell on the E-HICH indicated on E-AGCH.

The E-DCH Absolute Grant is transmitted by a single cell, the Serving E-DCH cell (Cell e_s on figure 4) on a physical channel called E-AGCH. The Serving E-DCH cell and the HS-DSCH Serving cell are identical.

The E-DCH Relative Grants (FDD only) can be transmitted by each cell of the E-DCH active set on a physical channel called E-RGCH. The E-RGCHs of the cells belonging to the same serving E-DCH RLS shall have the same content and be combined by the UE. There is one Serving E-DCH RLS (containing the Serving E-DCH cell) and optionally one or several Non-serving E-DCH RL(s).

In FDD mode and CELL_DCH state when Dual Cell E-DCH operation is configured, for each activated uplink frequency the F-DPCH, E-AGCH, E-RGCH and E-HICH are transmitted on the corresponding downlink frequency. The E-DCH Absolute Grant and E-DCH Relative Grants are provided per uplink frequency.

In FDD mode and CELL_DCH state when uplink CLTD is configured, the corresponding Transmitted Precoding Indicator is carried on the F-TPICH. The F-TPICH is either transmitted by a single cell which determines the precoding weights, or transmitted by all the cells within the RLS that the cell which determines the precoding weights belongs to.

In FDD mode and CELL_DCH state, when uplink MIMO is configured, the corresponding Transmitted Precoding Indicator is carried on the F-TPICH. The F-TPICH is either transmitted by the serving E-DCH cell, or transmitted by all the cells within the RLS that the serving E-DCH cell belongs to. The E-ROCH physical channel, which is transmitted by the serving E-DCH cell, provides additional information on the transmission rank and offset.

7 Formats and configurations for L1 data transfer

7.1 General concepts about Transport Channels

Layer 2 is responsible for the mapping of data onto L1 via the L1/L2 interface that is formed by the transport channels. In order to describe how the mapping is performed and how it is controlled, some definitions and terms are required. The required definitions are given in the following subclauses. Note that the definitions are generic for all transport channel types, i.e. not only for DCHs.

All Transport Channels are defined as unidirectional (i.e. uplink or downlink). This means that a UE can have simultaneously (depending on the services and the state of the UE) one or several transport channels in the downlink, and one or more Transport Channel in the uplink.

7.1.1 Transport Block

This is the basic unit exchanged between L1 and MAC, for L1 processing.

Layer 1 adds a CRC for each Transport Block.

7.1.2 Transport Block Set

This is defined as a set of Transport Blocks, which are exchanged between L1 and MAC at the same time instance using the same transport channel.

In case of HS-DSCH and E-DCH the Transport Block Set consists of one Transport Block only.

7.1.3 Transport Block Size

This is defined as the number of bits in a Transport Block. The Transport Block Size is always fixed within a given Transport Block Set, i.e. all Transport Blocks within a Transport Block Set are equally sized.

7.1.4 Transport Block Set Size

This is defined as the number of bits in a Transport Block Set.

7.1.5 Transmission Time Interval

This is defined as the inter-arrival time of Transport Block Sets, and is equal to the periodicity at which a Transport Block Set is transferred by the physical layer on the radio interface. It is always a multiple of the minimum interleaving period (e.g. 10ms, the length of one Radio Frame). The MAC delivers one Transport Block Set to the physical layer every TTI.

Figure 6 shows an example where Transport Block Sets, at certain time instances, are exchanged between MAC and L1 via three parallel transport channels. Each Transport Block Set consists of a number of Transport Blocks. The Transmission Time Interval, i.e. the time between consecutive deliveries of data between MAC and L1, is also illustrated.

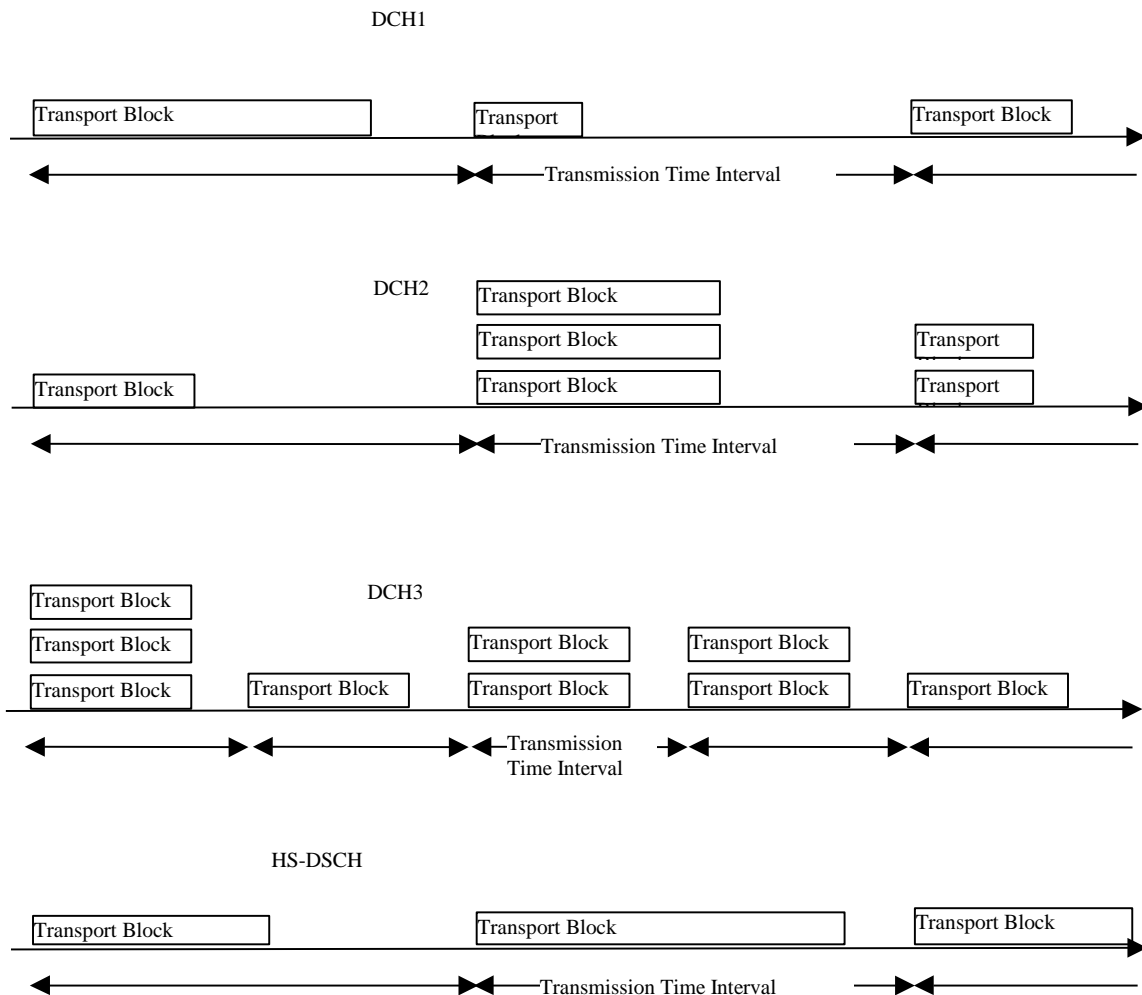

Figure 6: Exchange of data between MAC and L1

7.1.6 Transport Format

This subclause applies to transport channel types other than HS-DSCH and E-DCH.

This is defined as a format offered by L1 to MAC (and vice versa) for the delivery of a Transport Block Set during a Transmission Time Interval on a Transport Channel. The Transport Format constitutes of two parts – one *dynamic* part and one *semi-static* part.

Attributes of the dynamic part are:

- Transport Block Size;
- Transport Block Set Size;
- Transmission Time Interval (optional dynamic attribute for TDD only);

Attributes of the semi-static part are:

- Transmission Time Interval (mandatory for FDD, optional for the dynamic part of TDD NRT bearers);
- error protection scheme to apply:
 - type of error protection, turbo code, convolutional code or no channel coding (TDD only);
 - coding rate;
 - static rate matching parameter;
- size of CRC.

In the following example, the Transmission Time Interval is seen as a semi-static part.

EXAMPLE:

Dynamic part: { 320 bits, 640 bits }, Semi-static part: { 10ms, convolutional coding only, static rate matching parameter = 1 }.

An empty Transport Format is defined as a Transport Format that has Block Set Size equal to zero.

For the two realisations of an empty Transport Format, see clause 11.

7.1.6a Transport Format for HS-DSCH

This is defined as a format offered by L1 to MAC (and vice versa) for the delivery of a transport block during a Transmission Time Interval on a Transport Channel. The Transport Format consists of three parts – one *dynamic* part, one *semi-static* part and one *static* part.

The Transport Format for HS-DSCH is always explicitly signalled. There is no support of blind transport format detection.

Attributes of the dynamic part are:

- Transport block size (same as Transport block set size);
- Redundancy version/Constellation;
- Modulation scheme.

Attributes of the semi-static part are:

- no semi-static attributes are defined.

Attributes of the static part are:

- Transmission time interval. The Transmission time interval is fixed to 2ms in FDD, 10ms in 3.84/7.68 Mcps TDD and 5ms in 1.28 Mcps TDD.
- error protection scheme to apply:

- type of error protection is turbo coding;
- coding rate is 1/3;
- size of CRC is 24 bits.

7.1.7 Transport Format for E-DCH

This is defined as a format offered by L1 to MAC (and vice versa) for the delivery of a transport block during a Transmission Time Interval on a Transport Channel. The Transport Format consists of three parts – one *dynamic* part, one *semi-static* part and one *static* part.

The Transport Format for E-DCH is always explicitly signalled. There is no support of blind transport format detection.

Attributes of the dynamic part are:

- Transport block size (same as Transport block set size);
- Redundancy version;

Attributes of the semi-static part are:

- Transmission Time Interval. For FDD, both Transmission time interval of 2ms and 10 ms are supported; for 3.84 Mcps and 7.68 Mcps TDD only a Transmission time interval of 10 ms is supported, for 1.28 Mcps TDD only a transmission time interval of 5 ms is supported.

Attributes of the static part are:

- error protection scheme to apply:
 - type of error protection is turbo coding;
 - coding rate is 1/3;
 - size of CRC is 24 bits.

7.1.7a Transport Format Set

This is defined as the set of Transport Formats associated to a Transport Channel.

The semi-static parts of all Transport Formats are the same within a Transport Format Set.

Effectively the Transport Block Size and Transport Block Set Size form the instantaneous bit rate on the Transport Channel. Variable bit rate on a Transport Channel may, depending on the type of service, which is mapped on to the transport channel, be achieved by changing between each Transmission Time Interval one of the following:

1. the Transport Block Set Size only (not applicable for HS-DSCH and E-DCH);
2. both the Transport Block Size and the Transport Block Set Size

Example 1 for DCHs:

- dynamic part: { 20 bits, 20 bits }; { 40 bits, 40 bits }; { 80 bits, 80 bits }; { 160 bits, 160 bits }.
- Semi-static part: { 10ms, Convolutional coding only, static rate matching parameter = 1 }

Example 2 for DCHs:

- dynamic part: { 320 bits, 320 bits }; { 320 bits, 640 bits }; { 320 bits, 1 280 bits }.
- Semi-static part: { 10ms, Convolutional coding only, static rate matching parameter = 2 }.

Example 3 for HS-DSCH:

- dynamic part: { 320 bits, 320 bits, Redundancy version 1, QPSK }; { 640, 640, Redundancy version 1, QPSK }; { 1280, 1280, Redundancy version 2, 16QAM }.

- static part: See subclause 7.1.6a.

Example 4 for E-DCH:

- dynamic part: { 320 bits, 320 bits, Redundancy version 0 }; { 320 bits, 320 bits, Redundancy version 1 }; { 640, 640, Redundancy version 0 }; { 640, 640, Redundancy version 1 };
- Semi-static part: { 10ms }.
- static part: See subclause 7.1.7.

The first example may correspond to a Transport Channel carrying a speech service, requiring blocks delivered on a constant time basis. In the second example, which illustrates the situation where a non-real time service is carried by the Transport Channel, the number of blocks delivered per Transmission Time Interval varies between the different Transport Formats within the Transport Format Set. Referring to figure 6, the Transport Block Size is varied on DCH1 and DCH2. That is, a Transport Format Set where the dynamic part has a variable Transport Block Size has been assigned for DCH1. On DCH3 it is instead only the Transport Block Set Size that is varied. That is, the dynamic parts of the corresponding Transport Format Sets only include variable Transport Block Set Sizes.

7.1.8 Transport Format Combination

The layer 1 multiplexes one or several Transport Channels, and for each Transport Channel, there exists a list of transport formats (Transport Format Set) which are applicable. Nevertheless, at a given point of time, not all combinations may be submitted to layer 1 but only a subset, the Transport Format Combination. This is defined as an authorised combination of the combination of currently valid Transport Formats that can be submitted simultaneously to the layer 1 for transmission on a Coded Composite Transport Channel of a UE, i.e. containing one Transport Format from each Transport Channel.

EXAMPLE:

DCH1:

Dynamic part: { 20 bits, 20 bits }, Semi-static part: { 10ms, Convolutional coding only, static rate matching parameter = 2};

DCH2:

Dynamic part: { 320 bits, 1 280 bits }, Semi-static part: { 10ms, Convolutional coding only, static rate matching parameter = 3};

DCH3:

Dynamic part: { 320 bits, 320 bits }, Semi-static part: { 40ms, Turbo coding, static rate matching parameter = 2}.

An empty Transport Format Combination is defined as a Transport Format Combination that is only made up of empty Transport Formats.

7.1.9 Transport Format Combination Set

This is defined as a set of Transport Format Combinations on a Coded Composite Transport Channel.

EXAMPLE for DCHs:

- dynamic part:
 - combination 1: DCH1: { 20 bits, 20 bits }, DCH2: { 320 bits, 1280 bits }, DCH3: { 320 bits, 320 bits };
 - combination 2: DCH1: { 40 bits, 40 bits }, DCH2: { 320 bits, 1280 bits }, DCH3: { 320 bits, 320 bits };
 - combination 3: DCH1: { 160 bits, 160 bits }, DCH2: { 320 bits, 320 bits }, DCH3: { 320 bits, 320 bits }
- semi-static part:
 - DCH1: { 10ms, Convolutional coding only, static rate matching parameter = 1};
 - DCH2: { 10ms, Convolutional coding only, static rate matching parameter = 1};
 - DCH3: { 40ms, Turbo coding, static rate matching parameter = 2}.

The Transport Format Combination Set is what is given to MAC for control. However, the assignment of the Transport Format Combination Set is done by L3. When mapping data onto L1, MAC chooses between the different Transport Format Combinations given in the Transport Format Combination Set. Since it is only the dynamic part that differ between the Transport format Combinations, it is in fact only the dynamic part that MAC has any control over.

The semi-static part, together with the target value for the L1 closed loop power control, correspond to the service attributes:

- quality (e.g. BER);
- transfer delay.

These service attributes are then offered by L1. However, it is L3 that guarantees that the L1 services are fulfilled since it is in charge of controlling the L1 configuration, i.e. the setting of the semi-static part of the Transport Formats. Furthermore, L3 controls the target for the L1 closed loop power control through the outer loop power control (which actually is a quality control rather than a power control).

Note that a Transport Format Combination Set need not contain all possible Transport Format Combinations that can be formed by Transport Format Sets of the corresponding Transport Channels. It is only the allowed combinations that are included. Thereby a maximum total bit rate of all transport channels of a Code Composite Transport Channel can be set appropriately. That can be achieved by only allowing Transport Format Combinations for which the included Transport Formats (one for each Transport Channel) do not correspond to high bit rates simultaneously.

The selection of Transport Format Combinations can be seen as a fast part of the radio resource control. The dedication of these fast parts of the radio resource control to MAC, close to L1, means that the flexible variable rate scheme provided by L1 can be fully utilised. These parts of the radio resource control should be distinguished from the slower parts, which are handled by L3. Thereby the bit rate can be changed very fast, without any need for L3 signalling.

7.1.10 Transport Format Indicator (TFI)

The TFI is a label for a specific transport format within a transport format set. It is used in the inter-layer communication between MAC and L1 each time a transport block set is exchanged between the two layers on a transport channel.

When the DSCH is associated with a DCH, the TFI of the DSCH also indicates the physical channel (i.e. the channelisation code) of the DSCH that has to be listened to by the UE.

7.1.11 Transport Format Combination Indicator (TFCI)

This is a representation of the current Transport Format Combination.

There is a one-to-one correspondence between a certain value of the TFCI and a certain Transport Format Combination. The TFCI is used in order to inform the receiving side of the currently valid Transport Format Combination, and hence how to decode, de-multiplex and deliver the received data on the appropriate Transport Channels. The TFCI is not used for the HS-DSCH and E-DCH.

MAC indicates the TFI to Layer 1 at each delivery of Transport Block Sets on each Transport Channel. Layer 1 then builds the TFCI from the TFIs of all parallel transport channels of the UE, processes the Transport Blocks appropriately and appends the TFCI to the physical control signalling. Through the detection of the TFCI the receiving side is able to identify the Transport Format Combination. For FDD, in case of limited Transport Format Combination Sets the TFCI signalling may be omitted, instead relying on blind detection. Nevertheless, from the assigned Transport Format Combinations, the receiving side has all information it needs in order to decode the information and transfer it to MAC on the appropriate Transport Channels.

The multiplexing and exact rate matching patterns follow predefined rules and may therefore be derived (given the Transport Format Combinations) by transmitter and receiver without signalling over the radio interface.

When the meaning of the TFCI field needs to be reconfigured, two procedures can be used depending on the level of reconfiguration:

- **complete reconfiguration of TFCI:** in this procedure all TFCI values are reinitialised and new values are defined instead. The complete reconfiguration requires an explicit synchronisation between the UE and UTRAN regarding when the reconfiguration becomes valid.

- **incremental reconfiguration of TFCI:** in this procedures, a part of the TFCI values before and after the reconfiguration remain identical (note that this must be true for at least a TFCI that carry the signalling connection). This procedure supports addition, removal or redefinition of TFCI values. This procedure does not require an explicit execution time. This procedure may imply the loss of some user-plane data.

7.1.12 Rate matching

Two levels of rate matching are defined on the radio interface:

- a static rate matching per Transport Channel. The static rate matching is part of the semi-static attributes of the Transport Channel. Static rate matching is not applicable to HS-DSCH;
- a dynamic rate matching per CCTrCH. The dynamic rate matching adjusts the size of the physical layer data payload to the physical channel as requested by RRC.

The static rate matching and the dynamic rate matching to be applied by the physical layer are indicated by RRC to the physical layer.

In FDD, RRC is also responsible for configuring the physical layer on whether:

- Blind Rate Detection or TFCI is used;
- dynamic rate matching is applied or not on the downlink.

7.1.13 HARQ information

Hybrid ARQ is defined for HS-DSCH and E-DCH. For HS-DSCH with the help of the HARQ information the UE is enabled to identify the process being used for the transport block that is received on the HS-DSCH. For FDD E-DCH the HARQ process is derived in an implicit way. For TDD E-DCH the HARQ process identifier is signalled via the E-UCCH. For both HS-DSCH and E-DCH the HARQ information also includes information that indicates whether a new data block is transmitted for the first time or a retransmission. Furthermore it is used to decode the received data correctly. For FDD, the redundancy version is either explicitly indicated as part of the HARQ information (for the HS-DSCH) or is derived from the retransmission indicator (RSN) and the CFN and in case of 2ms TTI additionally from sub-frame number (for the E-DCH). For TDD, the redundancy version is either explicitly indicated as part of the HARQ information (for the HS-DSCH) or is derived from the retransmission indicator (RSN).

7.1.14 Transport Format and Resource Indication (TFRI)

The TFRI includes information about the dynamic part of the HS-DSCH transport format, including transport block set size and modulation scheme. The TFRI also includes information about the set of physical channels (channelisation codes) onto which HS-DSCH is mapped in the corresponding HS-DSCH TTI.

7.1.15 E-DCH Transport Format Combination Indication (E-TFCI)

The E-TFCI includes information about the transport block set size.

7.2 Types of Transport Channels

A general classification of transport channels is into two groups:

- common channels; and
- dedicated channels (where the UEs can be unambiguously identified by the physical channel, i.e. code and frequency).

Common transport channel types are:

1. Random Access Channel(s) (RACH) characterised by:
 - existence in uplink only;

- limited data field;
 - collision risk;
 - open loop power control.
2. Forward Access Channel(s) (FACH) characterised by:
- existence in downlink only;
 - possibility to use slow power control;
 - possibility to change rate fast (each 10ms); and
 - lack of inner loop power control.
3. Broadcast Channel (BCH) characterised by:
- existence in downlink only;
 - low fixed bit rate; and
 - requirement to be broadcast in the entire coverage area of the cell.
4. Paging Channel (PCH) characterised by:
- existence in downlink only;
 - association with a physical layer signal, the Page Indicator, to support efficient sleep mode procedures; and
 - requirement to be broadcast in the entire coverage area of the cell.
5. Downlink Shared Channel(s) (DSCH) characterised by:
- used in TDD only;
 - existence in downlink only;
 - possibility to use beamforming;
 - possibility to use slow power control;
 - possibility to use inner loop power control, when associated with dedicated channel(s);
 - possibility to be broadcast in the entire cell;
 - always associated with another channel (DCH or FACH).
6. Uplink Shared channel (USCH) characterised by:
- used in TDD only;
 - existence in uplink only;
 - possibility to use beam forming;
 - possibility to use power control;
 - possibility to change rate fast;
 - possibility to use Uplink Synchronisation;
 - possibility to use Timing advance.
7. High Speed Downlink Shared Channel (HS-DSCH) characterised by:
- existence in downlink only;
 - possibility to use beamforming;

- possibility to use MIMO;
- possibility to use MIMO mode with four transmit antennas;
- for FDD, possibility to be configured into Dual Cell operation;
- for FDD, possibility to be configured into Dual Band operation;
- for FDD, possibility to be configured into Four Carrier operation;
- for FDD, possibility to be configured into Eight Carrier operation;
- for FDD, possibility to be configured into the Multiflow operation;
- possibility of applying HARQ;
- possibility of applying link adaptation by varying the modulation, coding and transmit power;
- possibility to be broadcast in the entire cell;
- associated with a DPCH or F-DPCH (CELL_DCH state only) and one or more shared physical control channel.
- In FDD and 1.28Mcps TDD, in CELL_FACH, CELL_PCH and URA_PCH states associated with one or more shared physical control channel.

8. Dedicated Channel (E-DCH) characterised by (FDD and 1.28Mcps TDD only):

- existing in uplink only for CELL_FACH state and Idle mode;
- for FDD, collision risk, with collision resolution possible if E-RNTI is allocated to the UE;
- for 1.28Mcps TDD, E-RNTI collision risk, with collision resolution possible in case of CCCH transmission;
- possibility to change rate fast (each TTI) after collision resolution;
- inner loop power control;
- possibility of applying HARQ;
- possibility of applying link adaptation by varying the coding and transmit power;
- for FDD, E-DCH is always associated with a DPCCCH and one or more physical control channel.
- for 1.28Mcps TDD, E-DCH is always associated with uplink and downlink physical control channels.

Dedicated transport channel type:

1. Dedicated Channel (DCH) characterised by:

- existing in uplink or downlink;
- for FDD and in uplink, possibility to be configured into CLTD operation;
- possibility to use beam forming;
- possibility to change rate fast (each 10ms);
- inner loop power control;
- possibility to use timing advance in uplink (TDD only);
- possibility to use Uplink Synchronisation.

2. Dedicated Channel (E-DCH) characterised by:

- existing in uplink only;
- for FDD, possibility to be configured into Dual Cell operation;

- for FDD, possibility to be configured into CLTD operation;
- for FDD, possibility to be configured into uplink MIMO operation;
- possibility to change rate fast (each TTI);
- inner loop power control;
- possibility of applying HARQ;
- possibility of applying link adaptation by varying the coding and transmit power;
- For FDD, E-DCH is always associated with a DPCCH and one or more physical control channel.
- For TDD, E-DCH is always associated with uplink and downlink physical control channels.
- For 1.28 Mcps TDD, the possibility to be configured into multi-carrier operation.

To each transport channel, there is an associated Transport Format (for transport channels with a fixed or slow changing rate) or an associated Transport Format Set (for transport channels with fast changing rate).

7.3 Compressed Mode

Compressed Mode is defined as the mechanism whereby certain idle periods are created in radio frames so that the UE can perform measurements during these periods (more details can be found in [3]).

Compressed Mode is obtained by layer 2 using transport channels provided by the layer 1 as follows:

- compressed mode is controlled by the RRC layer, which configures the layer 2 and the physical layer;
- the number of occurrences of compressed frames is controlled by RRC, and can be modified by RRC signalling;
- it is under the responsibility of the layer 2 if necessary and if possible to either buffer some layer 2 PDUs (typically at the RLC layer for NRT services) or to rate-adapt the data flow (similarly to GSM) so that there is no loss of data because of compressed mode. This will be service dependent and controlled by the RRC layer.

For measurements in compressed mode, a transmission gap pattern sequence is defined. A transmission gap pattern sequence consists of alternating transmission gap patterns 1 and 2, and each of these patterns in turn consists of one or two transmission gaps. The transmission gap pattern structure, position and repetition are defined with physical channel parameters described in [6]. In addition, the UTRAN configures compressed mode pattern sequences with the following parameters:

- **TGMP:** Transmission Gap pattern sequence Measurement Purpose: This parameter defines the purpose this transmission gap pattern sequence is intended for. The following values are used:
 - for TDD measurements, one compressed mode pattern sequence can be configured with purpose 'TDD measurement',
 - for FDD measurements, one compressed mode pattern sequence can be configured with purpose 'FDD measurement',
 - for GSM measurements, three simultaneous compressed mode pattern sequences can be configured with purposes 'GSM carrier RSSI measurement', 'Initial BSIC identification' and 'BSIC re-confirmation',
- **TGPSI:** Transmission Gap Pattern Sequence Identifier selects the compressed mode pattern sequence for which the parameters are to be set. The range of TGPSI is [1 to <MaxTGPS>].

The UE shall support a total number of simultaneous compressed mode pattern sequences, which is determined by the UE's capability to support each of the measurement types categorised by the TGMP. For example, a UE supporting FDD and GSM shall support four simultaneous compressed mode pattern sequences and a UE supporting FDD and TDD shall support two simultaneous compressed mode pattern sequences.

When using simultaneous pattern sequences, it is the responsibility of the NW to ensure that the compressed mode gaps do not overlap and are not scheduled to overlap the same frame. Gaps exceeding the maximum gap length shall not be

processed by the UE and shall be interpreted as a faulty message. If the UE detects overlapping gaps, it shall process the gap from the pattern sequence having the lowest TGPSI.

8 UE Simultaneous Physical Channels combinations

This clause describes the requirements from the UE to send and receive on multiple Transport Channels, which are mapped on different physical channels simultaneously depending on the service capabilities and requirements. The clause will describe the impacts on the support for multiple services (e.g. speech call and SMS-CB) depending on the UE capabilities.

8.1 FDD Uplink

The table 1-1 describes the possible combinations of FDD physical channels that can be supported in the uplink on the same frequency by one UE simultaneously.

Table 1-1: FDD Uplink

	Physical Channel Combination	Transport Channel Combination	Mandatory or dependent on UE radio access capabilities	Comment
1	PRACH	RACH	Mandatory	The PRACH physical channel includes the preambles and the message.
2	(Void)			
3	DPCCH+DPDCH	One or more DCH coded into a single CTrCH	Mandatory	The maximum number of DCHs and the maximum channel bit rate are dependent on UE radio access capabilities.
4	DPCCH+ more than one DPDCH	One or more DCH coded into a single CTrCH	Depending on UE radio access capabilities	The maximum number of DCHs and the maximum channel bit rate are dependent on UE radio access capabilities.
5	DPCCH+one or more DPDCH+HS-DPCCH	One or more DCH coded into a single CTrCH	Depending on UE radio access capabilities	The maximum number of DCHs and the maximum bit rate are dependent on UE radio access capabilities. In this combination HS-DSCH(s) are configured in downlink.
6	DPCCH+one or more DPDCH+E-DPCCH+one or more E-DPDCH	One or more DCH coded into a single CTrCH + One E-DCH	Depending on UE radio access capabilities	The maximum number of DCHs and the maximum channel bit rate are dependent on UE radio access capabilities.
7	DPCCH+one or more DPDCH+HS-DPCCH+E-DPCCH+ one or more E-DPDCH	One or more DCH coded into a single CTrCH + One E-DCH	Depending on UE radio access capabilities	The maximum number of DCHs and the maximum bit rate are dependent on UE radio access capabilities. In this combination HS-DSCH(s) are configured in downlink.
8	DPCCH+HS-DPCCH+E-DPCCH+ one or more E-DPDCH	One E-DCH	Depending on UE radio access capabilities	The maximum bit rate is dependent on UE radio access capabilities. In this combination HS-DSCH(s) are configured in downlink.
9	DPCCH+E-DPCCH+ one or more E-DPDCH	One E-DCH	Depending on UE radio access capabilities	The maximum bit rate is dependent on UE radio access capabilities. In this combination HS-DSCH(s) are configured in downlink.
10	DPCCH+one or more DPDCH+S-DPCCH	One or more DCH coded into a single CTrCH	Depending on UE radio access capabilities	The maximum number of DCHs and the maximum channel bit rate are dependent on UE radio access capabilities. In this combination CLTD is configured in uplink.
11	DPCCH+one or more DPDCH+HS-DPCCH+S-DPCCH	One or more DCH coded into a single CTrCH	Depending on UE radio access capabilities	The maximum number of DCHs and the maximum bit rate are dependent on UE radio access capabilities. In this combination HS-DSCH(s) are configured in downlink and CLTD is configured in uplink.
12	DPCCH+one or more DPDCH+HS-DPCCH+E-DPCCH+ one or more E-DPDCH+S-DPCCH	One or more DCH coded into a single CTrCH + One E-DCH	Depending on UE radio access capabilities	The maximum number of DCHs and the maximum bit rate are dependent on UE radio access capabilities. In this combination HS-DSCH(s) are configured in downlink and CLTD is configured in uplink.
13	DPCCH+HS-DPCCH+E-DPCCH+ one or more E-DPDCH+S-DPCCH	One E-DCH	Depending on UE radio access capabilities	The maximum bit rate is dependent on UE radio access capabilities. In this combination HS-DSCH(s) are configured in downlink and CLTD is configured in uplink.
14	DPCCH+HS-DPCCH+E-DPCCH+S-E-DPCCH+one or more E-DPDCH+S-DPCCH+one or more S-E-DPDCH	One E-DCH	Depending on UE radio access capabilities	The maximum bit rate is dependent on UE radio access capabilities. In this combination HS-DSCH(s) are configured in downlink and MIMO is configured in uplink.

The table 1-2 describes the possible combinations of FDD physical channels that can be supported in the uplink on two configured uplink frequencies by one UE simultaneously.

Table 1-2: FDD Uplink

Physical Channel Combination	Physical Channel Combination on Primary uplink frequency	Physical Channel Combination on Secondary uplink frequency	Mandatory or dependent on UE radio access capabilities	Comment
A	8	9	Depending on UE radio access capabilities	In this combination HS-DSCH(s) are configured on each corresponding downlink frequency.

8.2 FDD Downlink

The table 2-1 describes the possible combinations of FDD physical channels that can be supported in the downlink on the same frequency by one UE simultaneously.

Table 2-1: FDD Downlink

	Physical Channel Combination	Transport Channel Combination	Mandatory dependent on UE radio access capabilities	Comment
1	PCCPCH	BCH	Mandatory	
2	SCCPCH	One or more FACH Or PCH Or one or more FACH + PCH	Mandatory	The maximum channel bit rate that can be supported is dependent on the UE radio access capabilities. The PCH is included when the UE needs to receive paging on the SCCPCH. The reception of (one or more FACH + PCH) is to enable the reception of broadcast services on the CTCH, mapped to one of the FACH.
3	PCCPCH + SCCPCH	BCH + (one or more FACH or PCH or (one or more FACH + PCH))	Mandatory	Simultaneous reception of PCCPCH and SCCPCH is only needed at occurrences when the UE needs to read system information on BCH while being in CELL_FACH state, i.e. continuous reception of both PCCPCH and SCCPCH at the same time is not required. The requirement holds for PCCPCH and SCCPCH sent in different cells or in the same cell. The PCH is included when the UE needs to receive paging on the SCCPCH. The reception of (one or more FACH + PCH) is to enable the reception of broadcast services on the CTCH, mapped to one of the FACH.
4	SCCPCH + AICH	(One or more FACH or PCH or (one or more FACH + PCH))+ RACH in uplink	Mandatory	The maximum channel bit rate that can be supported is dependent on the UE radio access capabilities. The PCH is included when the UE needs to receive paging on the SCCPCH. The reception of (one or more FACH + PCH) is to enable the reception of broadcast services on the CTCH, mapped to one of the FACH.
5	(Void)			
6	More than one SCCPCH	More than one (one or more FACH or PCH or (one or more FACH + PCH))	Depending on UE radio access capabilities	The PCH is included when the UE needs to receive paging on the SCCPCH. The reception of (one or more FACH + PCH) is to enable the reception of broadcast services on the CTCH, mapped to one of the FACH. One or more FACHs are used to enable the reception of MBMS (i.e., MCCH, MSCH and MTCH). The maximum number of SCCPCHs and the maximum bit rate depend on the UE implementation. The combination includes the case where one or more MBMS FACHs are transmitted on the same SCCPCH as used for non-MBMS FACH or PCH.
7	PICH	N/A	Mandatory	
8	DPCCH + DPDCH	One or more DCH coded into a single CTrCH	Mandatory	The maximum number of DCHs and the maximum channel bit rate are dependent on UE radio access capabilities.
9	DPCCH + more than one DPDCH	One or more DCH coded into a single CTrCH	Depending on UE radio access capabilities	The maximum number of DCHs and the maximum channel bit rate are dependent on UE radio access capabilities.
10	(Void)			

	Physical Channel Combination	Transport Channel Combination	Mandatory dependent on UE radio access capabilities	Comment
11	(Void)			
12	(Void)			
13	One DPCCH + more than one DPDCH	More than one DCH coded into one or more CCTrCH	Depending on UE radio access capabilities	
14	PCCPCH (neighbour cell) + DPCCH + one or more DPDCH	BCH (neighbour cell) + one or more DCHs	Mandatory	This combination is required by a UE in CELL_DCH state to be able to read the SFN of a neighbouring cell and support "SFN-CFN observed time difference" and "SFN-SFN observed time difference" measurements.
15	DPCCH + one or more DPDCH + one or more HS-SCCH + zero, one or more HS-PDSCH	One or more DCH coded into a single CCTrCH + one or two HS-DSCH	Depending on UE radio access capabilities	The maximum number of DCHs and the maximum channel bit rate are dependent on UE radio access capabilities. NOTE
16	PCCPCH (neighbour cell) + DPCCH + one or more DPDCH + one or more HS-SCCH + zero, one or more HS-PDSCH	BCH (neighbour cell) + one or more DCHs + one or two HS-DSCH	Depending on UE radio access capabilities	This combination is required by a UE in CELL_DCH state to be able to read the SFN of a neighbouring cell and support "SFN-CFN observed time difference" and "SFN-SFN observed time difference" measurements while HS-DSCH(s) are configured. NOTE
17	DPCCH + one or more DPDCH + one or more E-HICH + one E-AGCH + zero, one or more E-RGCH	One or more DCH coded into a single CCTrCH	Depending on UE radio access capabilities	The maximum number of DCHs and the maximum channel bit rate are dependent on UE radio access capabilities. In this combination E-DCH is configured in uplink.
18	DPCCH + one or more DPDCH + one or more HS-SCCH + zero, one or more HS-PDSCH + one or more E-HICH + one E-AGCH + zero, one or more E-RGCH	One or more DCH coded into a single CCTrCH + one or two HS-DSCH	Depending on UE radio access capabilities	The maximum number of DCHs and the maximum channel bit rate are dependent on UE radio access capabilities. In this combination E-DCH is configured in uplink. NOTE
19	PCCPCH (neighbour cell) + DPCCH + one or more DPDCH + one or more HS-SCCH + zero, one or more HS-PDSCH + one or more E-HICH + E-AGCH + zero, one or more E-RGCH	BCH (neighbour cell) + one or more DCHs + one or two HS-DSCH	Depending on UE radio access capabilities	This combination is required by a UE in CELL_DCH state to be able to read the SFN of a neighbouring cell and support "SFN-CFN observed time difference" and "SFN-SFN observed time difference" measurements while HS-DSCH(s) are configured. In this combination E-DCH is configured in uplink. NOTE
20	F-DPCH + one or more HS-SCCH + zero, one or more HS-PDSCH	One or two HS-DSCH	Depending on UE radio access capabilities	The maximum channel bit rate is dependent on UE radio access capabilities. NOTE

	Physical Channel Combination	Transport Channel Combination	Mandatory dependent on UE radio access capabilities	Comment
21	PCCPCH (neighbour cell) + F-DPCH + one or more HS-SCCH + zero, one or more HS-PDSCH	BCH (neighbour cell) + one or two HS-DSCH	Depending on UE radio access capabilities	This combination is required by a UE in CELL_DCH state to be able to read the SFN of a neighbouring cell and support "SFN-CFN observed time difference" and "SFN-SFN observed time difference" measurements while HS-DSCH(s) are configured. NOTE
22	F-DPCH + one or more HS-SCCH + zero, one or more HS-PDSCH+ one or more E-HICH + one E-AGCH + zero, one or more E-RGCH	One or two HS-DSCH	Depending on UE radio access capabilities	The maximum channel bit rate is dependent on UE radio access capabilities. In this combination E-DCH is configured in uplink. NOTE
23	PCCPCH (neighbour cell) + F-DPCH + one or more HS-SCCH + zero, one or more HS-PDSCH+ one or more E-HICH + one E-AGCH + zero, one or more E-RGCH	BCH (neighbour cell) + one or two HS-DSCH	Depending on UE radio access capabilities	This combination is required by a UE in CELL_DCH state to be able to read the SFN of a neighbouring cell and support "SFN-CFN observed time difference" and "SFN-SFN observed time difference" measurements while HS-DSCH(s) are configured. In this combination E-DCH is configured in uplink. NOTE
24	MICH	N/A	Depending on UE radio access capabilities	
25	MICH + PICH	N/A	Depending on UE radio access capabilities	
26	MICH + one SCCPCH	More than one (one or more FACH or PCH or (one or more FACH + PCH))	Depending on UE radio access capabilities	Allowing MBMS notification indication during reception of non-MBMS FACH or PCH.
27	PICH + one or more SCCPCH	One or more FACH	Depending on UE radio access capabilities	The maximum number of SCCPCHs and the maximum bit rate depend on the UE implementation.
28	PCCPCH + one or more HS-SCCH + zero, one or more HS-PDSCH + SCCPCH	BCH + one HS-DSCH + one or more FACH	Depending on UE radio access capabilities	Simultaneous reception of PCCPCH, SCCPCH and HS-SCCH is only needed at occurrences when the UE needs to read system information on BCH while being in CELL_PCH state, i.e. continuous reception of PCCPCH, and SCCPCH and HS-SCCH at the same time is not required. SCCPCH and HS-SCCH are to be detected at the same time. One HS-DSCH is used in CELL_PCH state to enable the reception of BCCH, DCCH, DTCH, or PCCH logical channel data. In CELL_PCH state the reception of one or more FACH is to enable the reception of broadcast services on the CTCH, mapped to one of the FACH. The requirement holds for PCCPCH, SCCPCH and HS-SCCH sent in different cells or in the same cell. NOTE

	Physical Channel Combination	Transport Channel Combination	Mandatory dependent on UE radio access capabilities	Comment
29	Zero, one or more HS-SCCHs + zero, one or more HS-PDSCH	One HS-DSCH	Depending on UE radio access capabilities	One HS-DSCH is used in CELL_FACH state to enable the reception of BCCH, CCCH, DCCH, or DTCH logical channel data. One HS-DSCH is used in CELL_PCH state to enable reception of BCCH, DCCH, DTCH or PCCH logical channel. One HS-DSCH is used in URA_PCH state to enable reception of PCCH logical channel. This combination is required by a UE in CELL_DCH state to be able to receive the HS-DSCH on the secondary DL frequency or the primary DL frequency. NOTE
30	One or more HS-SCCHs + zero, one or more HS-PDSCH + more than one SCCPCH	One HS-DSCH + one or more FACH	Depending on UE radio access capabilities	One HS-DSCH is used in CELL_FACH state to enable the reception of BCCH, CCCH, DCCH, or DTCH logical channel data. One HS-DSCH is used in CELL_PCH state to enable reception of BCCH, DCCH, DTCH or PCCH logical channel. In CELL_PCH state the reception of (one or more FACH) is to enable the reception of broadcast services on the CTCH, mapped to one of the FACH. One or more FACHs are used to enable the reception of MBMS (i.e., MCCH, MSCH and MTCH) in CELL_FACH or CELL_PCH state. The maximum number of SCCPCHs and the maximum bit rate depend on the UE implementation. The combination includes the case where one or more MBMS FACHs are transmitted on the same SCCPCH as used for non-MBMS FACH. NOTE
31	MICH + one or more HS-SCCH + zero, one or more HS-PDSCH + SCCPCH	One HS-DSCH	Depending on UE radio access capabilities	Allowing reception of MBMS notification indication during reception of HS-DSCH in CELL_FACH state.
32	DPCCH + one or more DPDCH +F-TPICH	More than one DCH coded into one or more CCTrCH	Depending on UE radio access capabilities	The maximum number of DCHs and the maximum channel bit rate are dependent on UE radio access capabilities. In this combination CLTD is configured in uplink.
33	PCCPCH (neighbour cell) + DPCCH + one or more DPDCH+F-TPICH	BCH (neighbour cell) + one or more DCHs	Depending on UE radio access capabilities	This combination is required by a UE in CELL_DCH state to be able to read the SFN of a neighbouring cell and support "SFN-CFN observed time difference" and "SFN-SFN observed time difference" measurements while CLTD is configured in uplink.
34	DPCCH + one or more DPDCH + one or more HS-SCCH + zero, one or more HS-PDSCH+F-TPICH	One or more DCH coded into a single CCTrCH + one or two HS-DSCH	Depending on UE radio access capabilities	The maximum number of DCHs and the maximum channel bit rate are dependent on UE radio access capabilities. In this combination CLTD is configured in uplink. NOTE
35	PCCPCH (neighbour cell) + DPCCH + one or more DPDCH + one or more HS-SCCH + zero, one or more HS-PDSCH +F-TPICH	BCH (neighbour cell) + one or more DCHs + one or two HS-DSCH	Depending on UE radio access capabilities	This combination is required by a UE in CELL_DCH state to be able to read the SFN of a neighbouring cell and support "SFN-CFN observed time difference" and "SFN-SFN observed time difference" measurements while HS-DSCH(s) are configured. In this combination CLTD is configured in uplink. NOTE

	Physical Channel Combination	Transport Channel Combination	Mandatory dependent on UE radio access capabilities	Comment
36	DPCCH + one or more DPDCH + one or more HS-SCCH + zero, one or more HS-PDSCH + one or more E-HICH + one E-AGCH + zero, one or more E-RGCH + F-TPICH	One or more DCH coded into a single CCTrCH + one or two HS-DSCH	Depending on UE radio access capabilities	The maximum number of DCHs and the maximum channel bit rate are dependent on UE radio access capabilities. In this combination E-DCH and CLTD is configured in uplink. NOTE
37	PCCPCH (neighbour cell) + DPCCH + one or more DPDCH + one or more HS-SCCH + zero, one or more HS-PDSCH + one or more E-HICH + E-AGCH + zero, one or more E-RGCH + F-TPICH	BCH (neighbour cell) + one or more DCHs + one or two HS-DSCH	Depending on UE radio access capabilities	This combination is required by a UE in CELL_DCH state to be able to read the SFN of a neighbouring cell and support "SFN-CFN observed time difference" and "SFN-SFN observed time difference" measurements while HS-DSCH(s) are configured. In this combination E-DCH and CLTD is configured in uplink. NOTE
38	F-DPCH + one or more HS-SCCH + zero, one or more HS-PDSCH + F-TPICH	One or two HS-DSCH	Depending on UE radio access capabilities	The maximum channel bit rate is dependent on UE radio access capabilities. In this combination CLTD is configured in uplink. NOTE
39	PCCPCH (neighbour cell) + F-DPCH + one or more HS-SCCH + zero, one or more HS-PDSCH + F-TPICH	BCH (neighbour cell) + one or two HS-DSCH	Depending on UE radio access capabilities	This combination is required by a UE in CELL_DCH state to be able to read the SFN of a neighbouring cell and support "SFN-CFN observed time difference" and "SFN-SFN observed time difference" measurements while HS-DSCH(s) are configured. In this combination CLTD is configured in uplink. NOTE
40	F-DPCH + one or more HS-SCCH + zero, one or more HS-PDSCH + one or more E-HICH + one E-AGCH + zero, one or more E-RGCH + F-TPICH	One or two HS-DSCH	Depending on UE radio access capabilities	The maximum channel bit rate is dependent on UE radio access capabilities. In this combination E-DCH and CLTD is configured in uplink. NOTE

	Physical Channel Combination	Transport Channel Combination	Mandatory dependent on UE radio access capabilities	Comment
41	PCCPCH (neighbour cell) + F-DPCH + one or more HS-SCCH + zero, one or more HS-PDSCH+ one or more E-HICH + one E-AGCH + zero, one or more E-RGCH+F-TPICH	BCH (neighbour cell) + one or two HS-DSCH	Depending on UE radio access capabilities	This combination is required by a UE in CELL_DCH state to be able to read the SFN of a neighbouring cell and support "SFN-CFN observed time difference" and "SFN-SFN observed time difference" measurements while HS-DSCH(s) are configured. In this combination E-DCH and CLTD is configured in uplink. NOTE
42	DPCCH + one or more DPDCH + one or more HS-SCCH + zero, one or more HS-PDSCH+ one or more E-HICH + one E-AGCH + zero, one or more E-RGCH+F-TPICH + one E-ROCH	One or more DCH coded into a single CCTrCH + one or two HS-DSCH	Depending on UE radio access capabilities	The maximum number of DCHs and the maximum channel bit rate are dependent on UE radio access capabilities. In this combination E-DCH and uplink MIMO is configured in uplink. NOTE
43	PCCPCH (neighbour cell) + DPCCH + one or more DPDCH + one or more HS-SCCH + zero, one or more HS-PDSCH + one or more E-HICH + E-AGCH + zero, one or more E-RGCH+F-TPICH + one E-ROCH	BCH (neighbour cell) + one or more DCHs + one or two HS-DSCH	Depending on UE radio access capabilities	This combination is required by a UE in CELL_DCH state to be able to read the SFN of a neighbouring cell and support "SFN-CFN observed time difference" and "SFN-SFN observed time difference" measurements while HS-DSCH(s) are configured. In this combination E-DCH and UL MIMO is configured in uplink. NOTE
44	F-DPCH + one or more HS-SCCH + zero, one or more HS-PDSCH+ one or more E-HICH + one E-AGCH + zero, one or more E-RGCH+F-TPICH + one E-ROCH	One or two HS-DSCH	Depending on UE radio access capabilities	The maximum channel bit rate is dependent on UE radio access capabilities. In this combination E-DCH and UL MIMO is configured in uplink. NOTE

	Physical Channel Combination	Transport Channel Combination	Mandatory dependent on UE radio access capabilities	Comment
45	PCCPCH (neighbour cell) + F-DPCH + one or more HS-SCCH + zero, one or more HS-PDSCH+ one or more E-HICH + one E-AGCH + zero, one or more E-RGCH+F-TPICH + one E-ROCH	BCH (neighbour cell) + one or two HS-DSCH	Depending on UE radio access capabilities	This combination is required by a UE in CELL_DCH state to be able to read the SFN of a neighbouring cell and support "SFN-CFN observed time difference" and "SFN-SFN observed time difference" measurements while HS-DSCH(s) are configured. In this combination E-DCH and UL MIMO is configured in uplink. NOTE
NOTE: When one or more HS-PDSCHs are received, it is sufficient for the UE to monitor only one HS-SCCH.				

The table 2-2 describes the possible combinations of FDD physical channels that can be supported in the downlink on two, three, four, five, six, seven or eight configured downlink frequencies by one UE simultaneously depending on UE radio access capabilities.

Table 2-2: FDD Downlink

Physical Channel Combination	Physical Channel Combination on Primary downlink frequency	Physical Channel Combination on 1 st Secondary downlink frequency	Physical Channel Combination on 2 nd Secondary downlink frequency	Physical Channel Combination on 3 rd Secondary downlink frequency	Physical Channel Combination on 4 th Secondary downlink frequency	Physical Channel Combination on 5 th Secondary downlink frequency	Physical Channel Combination on 6 th Secondary downlink frequency	Physical Channel Combination on 7 th Secondary downlink frequency	Comment
A1	15	29	n/a	n/a	n/a	n/a	n/a	n/a	
A2	16	29	n/a	n/a	n/a	n/a	n/a	n/a	
A3	18	29	n/a	n/a	n/a	n/a	n/a	n/a	NOTE 1
A4	19	29	n/a	n/a	n/a	n/a	n/a	n/a	NOTE 1
A5	15	29	29	n/a	n/a	n/a	n/a	n/a	
A6	15	29	29	29	n/a	n/a	n/a	n/a	
A7	16	29	29	n/a	n/a	n/a	n/a	n/a	
A8	16	29	29	29	n/a	n/a	n/a	n/a	
A9	18	29	29	n/a	n/a	n/a	n/a	n/a	NOTE 1
A10	18	29	29	29	n/a	n/a	n/a	n/a	NOTE 1
A11	19	29	29	n/a	n/a	n/a	n/a	n/a	NOTE 1
A12	19	29	29	29	n/a	n/a	n/a	n/a	NOTE 1
A13 to A16	15	29	29	29	29	29 or n/a	29 or n/a	29 or n/a	NOTE 3
A17 to A20	16	29	29	29	29	29 or n/a	29 or n/a	29 or n/a	NOTE 3
A21 to A24	18	29	29	29	29	29 or n/a	29 or n/a	29 or n/a	NOTE 1, NOTE 3
A25 to A28	19	29	29	29	29	29 or n/a	29 or n/a	29 or n/a	NOTE 1, NOTE 3
A29 to A35	34	29	29 or n/a	29 or n/a	29 or n/a	29 or n/a	29 or n/a	29 or n/a	NOTE 4 NOTE 5
A36 to A42	35	29	29 or n/a	29 or n/a	29 or n/a	29 or n/a	29 or n/a	29 or n/a	NOTE 4 NOTE 5
A43 to A49	36	29	29 or n/a	29 or n/a	29 or n/a	29 or n/a	29 or n/a	29 or n/a	NOTE 1 NOTE 4 NOTE 5
A50 to A56	37	29	29 or n/a	29 or n/a	29 or n/a	29 or n/a	29 or n/a	29 or n/a	NOTE 1 NOTE 4 NOTE 5
B1	20	29	n/a	n/a	n/a	n/a	n/a	n/a	
B2	21	29	n/a	n/a	n/a	n/a	n/a	n/a	
B3	22	29	n/a	n/a	n/a	n/a	n/a	n/a	NOTE 1
B4	23	29	n/a	n/a	n/a	n/a	n/a	n/a	NOTE 1
B5	20	29	29	n/a	n/a	n/a	n/a	n/a	
B6	20	29	29	29	n/a	n/a	n/a	n/a	
B7	21	29	29	n/a	n/a	n/a	n/a	n/a	
B8	21	29	29	29	n/a	n/a	n/a	n/a	
B9	22	29	29	n/a	n/a	n/a	n/a	n/a	NOTE 1
B10	22	29	29	29	n/a	n/a	n/a	n/a	NOTE 1
B11	23	29	29	n/a	n/a	n/a	n/a	n/a	NOTE 1
B12	23	29	29	29	n/a	n/a	n/a	n/a	NOTE 1
B13 to B16	20	29	29	29	29	29 or n/a	29 or n/a	29 or n/a	NOTE 3
B17 to B20	21	29	29	29	29	29 or n/a	29 or n/a	29 or n/a	NOTE 3
B21 to B24	22	29	29	29	29	29 or n/a	29 or n/a	29 or n/a	NOTE 1, NOTE 3
B25 to B28	23	29	29	29	29	29 or n/a	29 or n/a	29 or n/a	NOTE 1, NOTE 3

Physical Channel Combination	Physical Channel Combination on Primary downlink frequency	Physical Channel Combination on 1 st Secondary downlink frequency	Physical Channel Combination on 2 nd Secondary downlink frequency	Physical Channel Combination on 3 rd Secondary downlink frequency	Physical Channel Combination on 4 th Secondary downlink frequency	Physical Channel Combination on 5 th Secondary downlink frequency	Physical Channel Combination on 6 th Secondary downlink frequency	Physical Channel Combination on 7 th Secondary downlink frequency	Comment
B29 to B35	38	29	29 or n/a	29 or n/a	29 or n/a	29 or n/a	29 or n/a	29 or n/a	NOTE 4, NOTE 5
B36 to B42	39	29	29 or n/a	29 or n/a	29 or n/a	29 or n/a	29 or n/a	29 or n/a	NOTE 4, NOTE 5
B43 to B49	40	29	29 or n/a	29 or n/a	29 or n/a	29 or n/a	29 or n/a	29 or n/a	NOTE 1, NOTE 4, NOTE 5
B50 to B56	41	29	29 or n/a	29 or n/a	29 or n/a	29 or n/a	29 or n/a	29 or n/a	NOTE 1, NOTE 4, NOTE 5
C1	22	22	n/a	n/a	n/a	n/a	n/a	n/a	NOTE 2
C2	23	22	n/a	n/a	n/a	n/a	n/a	n/a	NOTE 2
C3	22	22	29	n/a	n/a	n/a	n/a	n/a	NOTE 2
C4	22	22	29	29	n/a	n/a	n/a	n/a	NOTE 2
C5	23	22	29	n/a	n/a	n/a	n/a	n/a	NOTE 2
C6	23	22	29	29	n/a	n/a	n/a	n/a	NOTE 2
C7 to C10	22	22	29	29	29	29 or n/a	29 or n/a	29 or n/a	NOTE 2, NOTE 3
C11 to C14	23	22	29	29	29	29 or n/a	29 or n/a	29 or n/a	NOTE 2, NOTE 3

NOTE 1: In this combination E-DCH is configured on the uplink frequency corresponding to the primary downlink frequency.

NOTE 2: In this combination E-DCH is configured on the uplink frequencies corresponding to the primary downlink frequency and 1st secondary downlink frequency.

NOTE 3: In these combinations, the 1st combination referred to has the 4th Secondary downlink frequency combination 29, the 2nd combination has the 4th and 5th Secondary downlink frequency combinations of 29, the 3rd combination has the 4th, 5th and 6th Secondary downlink frequency combination of 29, the 4th combination has the 4th, 5th, 6th and 7th Secondary downlink frequency combination 29.

NOTE 4: In these combinations, the 1st combination referred to has the 1st Secondary downlink frequency combination 29, the 2nd combination has the 1st and 2nd Secondary downlink frequency combination 29, the 3rd combination has the 1st, 2nd and 3rd Secondary downlink frequency combination 29, etc.

NOTE 5: In this combination CLTD is configured on the uplink frequency corresponding to the primary downlink frequency.

The table 2-3 describes the possible combinations of FDD physical channels that can be supported on two configured downlink and uplink frequencies by one UE simultaneously.

Table 2-3: FDD Downlink and Uplink

Physical Channel Combination	Downlink frequency		Uplink frequency	
	Primary	Secondary (1 st)	Primary	Secondary
D1	22	22	8	9
D2	23	22	8	9
D3	22	29	8	N/A
D4	23	29	8	N/A

The Table 2-4 describes the possible combinations of FDD physical channels that can be supported for Multiflow in the downlink on one or two configured downlink frequencies by one UE depending on UE radio capabilities.

Table 2-4: FDD Downlink (Multiflow)

Physical Channel Combination	Physical Channel Combination on Primary downlink frequency (serving cell)	Physical Channel Combination on Primary downlink frequency (assisting serving cell)	Physical Channel Combination on Secondary downlink frequency (secondary serving cell)	Physical Channel Combination on Secondary downlink frequency (assisting secondary serving cell)	Comment
E1 to E4	15	29	29 or n/a	29 or n/a	
E5 to E8	16	29	29 or n/a	29 or n/a	
E9 to E12	18	29	29 or n/a	29 or n/a	NOTE 1
E13 to E16	19	29	29 or n/a	29 or n/a	NOTE 1
E17 to E20	34	29	29 or n/a	29 or n/a	NOTE 2
E21 to E24	35	29	29 or n/a	29 or n/a	NOTE 2
E25 to E28	36	29	29 or n/a	29 or n/a	NOTE 1, NOTE 2
E29 to E32	37	29	29 or n/a	29 or n/a	NOTE 1, NOTE 2
E33 to E36	42	29	29 or n/a	29 or n/a	NOTE 1, NOTE 3
E37 to E40	43	29	29 or n/a	29 or n/a	NOTE 1, NOTE 3
F1 to F4	20	29	29 or n/a	29 or n/a	
F5 to F8	21	29	29 or n/a	29 or n/a	
F9 to F12	22	29	29 or n/a	29 or n/a	NOTE 1
F13 to F16	23	29	29 or n/a	29 or n/a	NOTE 1
F17 to F20	38	29	29 or n/a	29 or n/a	NOTE 2
F21 to F24	39	29	29 or n/a	29 or n/a	NOTE 2
F25 to F28	40	29	29 or n/a	29 or n/a	NOTE 1, NOTE 2
F29 to F32	41	29	29 or n/a	29 or n/a	NOTE 1, NOTE 2
F33 to F36	44	29	29 or n/a	29 or n/a	NOTE 1, NOTE 3
F37 to F40	45	29	29 or n/a	29 or n/a	NOTE 1, NOTE 3
NOTE 1: In this combination E-DCH is configured on the uplink frequency corresponding to the primary downlink frequency.					
NOTE 2: In this combination CLTD is configured on the uplink frequency corresponding to the primary downlink frequency.					
NOTE 3: In this combination UL MIMO is configured on the uplink frequency corresponding to the primary downlink frequency.					

8.3 TDD Uplink

8.3.1 3.84/7.68 Mcps TDD Uplink

The table addresses the possible combinations of 3.84/7.68 Mcps TDD physical channels that can be supported in the uplink by one UE simultaneously on the same frequency in any one 10ms frame. In 3.84/7.68 Mcps TDD a physical channel corresponds to one code, one timeslot and one frequency.

Table 3: 3.84/7.68 Mcps TDD Uplink

	Physical Channel Combination	Transport Channel Combination	Mandatory or dependent on UE radio access capabilities	Comment
1	PRACH	RACH	Mandatory	
2	DPCH	One or more DCH coded into a single CTrCH	Mandatory	The maximum number of DCHs and the maximum channel bit rate are dependent on UE radio access capabilities. This combination is used as reference measurement channel.
3	One or more than one DPCH	One or more DCH coded into one or more CTrCH	Depending on UE radio access capabilities	The maximum number of DCHs and the maximum channel bit rate are dependent on UE radio access capabilities.
4	PRACH + one or more DPCH	RACH + one or more DCH coded into one or more CTrCH	Depending on UE radio access capabilities	The maximum number of DCHs and the maximum channel bit rate are dependent on UE radio access capabilities. This combination may be used for shared channel operation only. At least the usage of two timeslots is required.
5	One or more PUSCH	One or more USCH coded onto one or more CTrCH	Depending on UE radio access capabilities	This combination is used for shared channel operation.
6	PRACH + one or more PUSCH	RACH + One or more USCH coded onto one or more CTrCH	Depending on UE radio access capabilities	This combination may be used for shared channel operation only. At least the usage of two timeslots is required.
7	One or more PUSCH + one or more DPCH	One or more USCH coded onto one or more CTrCH + one or more DCH coded into one or more CTrCH	Depending on UE radio access capabilities	The maximum number of DCHs and the maximum channel bit rate are dependent on UE radio access capabilities. This combination may be used for shared channel operation.
8	PRACH + one or more PUSCH + one or more DPCH	RACH + one or more USCH coded onto one or more CTrCH + one or more DCH coded into one or more CTrCH	Depending on UE radio access capabilities	The maximum number of DCHs and the maximum channel bit rate are dependent on UE radio access capabilities. This combination may be used for shared channel operation. At least the usage of two timeslots is required.
9	One or more DPCH + HS-SICH	One or more DCH coded into one or more CTrCH	Depending on UE radio access capabilities	
10	Zero, one or more DPCH + zero or one HS-SICH + E-RUCCH	One or more DCH	Depending on UE radio access capabilities	3.84 and 7.68 Mcps only. The maximum number of DCHs and the maximum channel bit rate are dependent on UE radio access capabilities
11	Zero, one or more DPCH + zero or one HS-SICH + one E-PUCH	One or more DCH + E-DCH	Depending on UE radio access capabilities	3.84 and 7.68 Mcps only. The maximum number of DCHs and the maximum channel bit rate are dependent on UE radio access capabilities

8.3.2 1.28 Mcps TDD Uplink

The table 4-1 addresses the possible combinations of 1.28 Mcps TDD physical channels that can be supported in the uplink by one UE simultaneously on the same frequency in the TDD 1.28 Mcps option in any one 5 ms subframe. In 1.28 Mcps TDD a physical channel corresponds to one code, one timeslot, one frequency.

Table 4-1: 1.28 Mcps TDD Uplink

	Physical Channel Combination	Transport Channel Combination	Mandatory or dependent on UE radio access capabilities	Comment
1	UpPCH	N/A	Mandatory	UpPCH is used to establish the uplink synchronisation.
2	PRACH	RACH	Mandatory	
3	UpPCH + One DPCH	One or more DCH coded into a single CCTrCH	Mandatory	One DPCH is needed as reference measurement channel. UpPCH transmission to target cell in case of handover.
4	One DPCH	One or more DCH coded into a single CCTrCH	Mandatory	The maximum number of DCHs and the maximum channel bit rate are dependent on UE radio access capabilities This combination is required for the reference measurement channel.
5	More than one DPCH	One or more DCH coded into one or more CCTrCH	Depending on UE radio access capabilities	The maximum number of DCHs, the maximum number of CCTrCH and the maximum channel bit rate are dependent on UE radio access capabilities.
6	UpPCH+ one or more DPCH	One or more DCH coded into one or more CCTrCH	Depending on UE radio access capabilities	The maximum number of DCHs, the maximum number of CCTrCH and the maximum channel bit rate are dependent on UE radio access capabilities. This configuration is required for UE that operate shared channels and dedicated channels simultaneously.
7	PRACH + one or more DPCHs	RACH + one or more DCH coded into one or more than one CCTrCH	Depending on UE radio access capabilities	The maximum number of DCHs, the maximum number of CCTrCH and the maximum channel bit rate are dependent on UE radio access capabilities. This configuration is required for UE that operate shared channels and dedicated channels simultaneously.
8	One or more PUSCH	One or more USCH coded onto one or more CCTrCH	Depending on UE radio access capabilities	This configuration is required for UE that operate shared channels.
9	UpPCH + one or more PUSCH	One or more USCH coded onto one or more CCTrCH	Depending on UE radio access capabilities	This combination may be used for shared channel operation only.
10	PRACH + one or more PUSCH	RACH + One or more USCH coded onto one or more CCTrCH	Depending on UE radio access capabilities	This combination may be used for shared channel operation only
11	One or more PUSCH + one or more DPCH	One or more USCH coded onto one or more CCTrCH + one or more DCH coded onto one or more CCTrCH	Depending on UE radio access capabilities	The maximum number of DCHs and the maximum channel bit rate are dependent on UE radio access capabilities. This configuration is required for UE that operate shared channels and dedicated channels simultaneously

	Physical Channel Combination	Transport Channel Combination	Mandatory or dependent on UE radio access capabilities	Comment
12	UpPCH + one or more PUSCH + one or more DPCH	One or more USCH coded onto one or more CCTrCH + one or more DCH coded into one or more CCTrCH	Depending on UE radio access capabilities	The maximum number of DCHs and the maximum channel bit rate are dependent on UE radio access capabilities. This combination may be used for shared channel operation.
13	PRACH + one or more PUSCH + one or more DPCH	RACH + one or more USCH coded onto one or more CCTrCH + one or more DCH coded into one or more CCTrCH	Depending on UE radio access capabilities	The maximum number of DCHs and the maximum channel bit rate are dependent on UE radio access capabilities. This combination may be used for shared channel operation.
14	One or more DPCH + HS-SICH	One or more DCH coded into one or more CCTrCH	Depending on UE radio access capabilities	
15	One or more DPCH + Zero or one HS-SICH + one or more E-RUCCH + E-PUCH	One or more DCH + one E-DCH	Depending on UE radio access capabilities	The maximum number of DCHs and the maximum channel bit rate are dependent on UE radio access capabilities
16	One HS-SICH + one or more E-RUCCH + E-PUCH	One E-DCH	Depending on UE radio access capabilities	The maximum channel bit rate are dependent on UE radio access capabilities

The table 4-2 describes the possible combinations of 1.28Mcps TDD physical channels that can be supported in the uplink on two or more configured uplink frequencies by one UE simultaneously.

Table 4-2: 1.28 Mcps TDD Uplink

Physical Channel Combination	Physical Channel Combination on Primary E-DCH carrier	Physical Channel Combination on Additional E-DCH carrier	Mandatory or dependent on UE radio access capabilities	Comment
1	zero or one DPCH + zero or one or more HS-SICH + one or more E-RUCCH + E-PUCH	zero or one or more HS-SICH + E-PUCH	Depending on UE radio access capabilities	The maximum number of E-DCHs and the maximum channel bit rate are dependent on UE radio access capabilities. In this combination HS-DSCH(s) are configured on each corresponding downlink frequency.

8.4 TDD Downlink

8.4.1 3.84/7.68 Mcps TDD Downlink

The table describes the possible combinations of 3.84/7.68 Mcps TDD physical channels that can be supported in the downlink by one UE simultaneously on the same frequency in any one 10ms frame, where a 3.84/7.68 Mcps TDD physical channel corresponds to one code, one timeslot and one frequency.

Depending on UE radio capabilities UEs may be required to decode occasionally P-CCPCH of its own cell in the following Physical Channel Combinations to maintain open loop power control and/or acquire parameters for RACH access: 4, 6, 7, 8, 9, 10, 11, 12, 13.

Depending on UE radio capabilities UEs may be required to decode occasionally one P-CCPCH of neighbour cells in the following Physical Channel Combinations for handover: 6, 8, 11, 12, 13.

Table 5: 3.84/7.68 Mcps TDD Downlink

	Physical Channel Combination	Transport Channel Combination	Mandatory or dependent on UE radio access capabilities	Comment
1	P-CCPCH + One S-CCPCH	BCH and PCH and/or one or more FACH	Mandatory	
2	P-CCPCH	BCH	Mandatory	
3	S-CCPCH	FACH or/and PCH	Mandatory	
4	More than one S-CCPCH	one or more FACH+ one or more PCH	Depending on UE capabilities	One or more FACHs are used to enable the reception of MBMS (i.e., MCCH, MSCH and MTCH). The maximum number of SCCPCHs and the maximum bit rate depend on the UE implementation. The combination includes the case where one or more MBMS FACHs are transmitted on the same SCCPCH as used for non-MBMS FACH or PCH.
5	PICH	N/A	Mandatory	
6	Three or more DPCH	One or more DCH coded into one or more CCTrCH	Depending on UE radio access capabilities	The maximum number of DCHs and the maximum channel bit rate are dependent on UE radio access capabilities.
7	One or two DPCH	One or more DCH coded into a single CCTrCH	Mandatory	This combination is used for reference measurement channel.
8	One or more S-CCPCH + one or more DPCH	PCH and/or one or more FACH + one or more DCH coded into one or more CCTrCH	Depending on UE radio access capabilities	The number of DCHs and the maximum channel bit rate are dependent on the UE radio access capabilities. This combination is used for shared channel operation only.
9	One or more PDSCH	One or more DSCH coded onto one or more CCTrCH	Depending on UE radio access capabilities	This combination is used for shared channel operation.
10	One or more PDSCH + one or more S-CCPCH	PCH and/or one or more FACH + one or more DSCH coded onto one or more CCTrCH	Depending on UE radio access capabilities	This combination is used for shared channel operation.

	Physical Channel Combination	Transport Channel Combination	Mandatory or dependent on UE radio access capabilities	Comment
11	One or more PDSCH + one or more DPCH	One or more DSCH coded onto one or more CTrCH + one or more DCH coded into one or more CTrCH	Depending on UE radio access capabilities	The maximum number of DCHs and the maximum channel bit rate are dependent on UE radio access capabilities. This combination is used for shared channel operation.
12	One or more PDSCH + one or more S-CCPCH + one or more DPCH	PCH and/or one or more FACH + one or more DSCH coded onto one or more CTrCH + one or more DCH coded into one or more CTrCH	Depending on UE radio access capabilities	The maximum number of DCHs and the maximum channel bit rate are dependent on UE radio access capabilities. This combination is used for shared channel operation.
13	Zero, one or more DPCH + zero, one or more HS-PDSCH + one or more HS-SCCH	Zero, one or more DCH coded into one or more CTrCH + one or more HS-DSCH coded into one CTrCH	Depending on UE radio access capabilities	
14	MICH	N/A	Depending on UE radio access capabilities	
15	MICH + PICH	N/A	Depending on UE radio access capabilities	
16	MICH + one or more SCCPCH	One or more FACH + one or more PCH + (NOTE 2)	Depending on UE radio access capabilities	Allowing MBMS notification indication during reception of non-MBMS FACH or PCH.
17	PICH + one or more SCCPCH	One or more FACH + (NOTE 2)	Depending on UE radio access capabilities	The maximum number of SCCPCHs and the maximum bit rate depend on the UE implementation.
18	MICH + PICH + one or more SCCPCH	One or more FACH + (NOTE 2)	Depending on UE radio access capabilities	The maximum number of SCCPCHs and the maximum bit rate depend on the UE implementation.
19	Zero, one or more DPCH + zero, one or more HS-PDSCH + one or more HS-SCCH + zero, one or more E-AGCH + zero or one E-HICH	Zero, one or more DCHs coded into zero, one or more CTrCH + one HS-DSCH	Depending on UE radio access capabilities	3.84 and 7.68 Mcps only.
NOTE 1: Reference: [12].				
NOTE 2: + (zero, one or more DCH coded onto one or more CTrCh) + (zero, one or more DSCH coded onto one or more CTrCH) + (zero, one or more HS-DSCH coded onto one or more CTrCH).				

8.4.2 1.28 Mcps TDD Downlink

The table 6-1 addresses the possible combinations of 1.28 Mcps TDD physical channels that can be supported in the downlink by one UE simultaneously on the same frequency in any one 5ms subframe. In 1.28 Mcps TDD a physical channel corresponds to one code, one timeslot, one frequency.

Depending on UE radio capabilities UEs may be required to decode occasionally P-CCPCH of its own cell in the following Physical Channel Combinations: 5, 11, 12, 13, 14, 15, 16, 17, 18.

To support handover it depends on UE capabilities if a UE can support the occasional decoding of neighbour cell P-CCPCH in the physical channel combinations 8, 9, 10, 11, 15,16, 17, 18.

Table 6-1: 1.28 Mcps TDD Downlink

	Physical Channel Combination	Transport Channel Combination	Mandatory or dependent on UE radio access capabilities	Comment
1	FPACH	N/A	Mandatory	FPACH is used to answer the UE and to adjust the timing and synchronization shift of the UE
2	P-CCPCH	BCH	Mandatory	
3	S-CCPCH	FACH or/and PCH	Mandatory	
4	P-CCPCH +S-CCPCH	BCH + (FACH or/and PCH)	Mandatory	
5	More than one S-CCPCH	one or more FACH+ one or more PCH	Depending on UE capabilities	One or more FACHs are used to enable the reception of MBMS (i.e., MCCH, MSCH and MTCH). The maximum number of SCCPCHs and the maximum bit rate depend on the UE implementation. The combination includes the case where one or more MBMS FACHs are transmitted on the same SCCPCH as used for non-MBMS FACH or PCH.
6	PICH	N/A	Mandatory	
7	FPACH + P-CCPCH + none, one or more S-CCPCH	BCH + (none, one or more FACH+ none, one or more PCH)	Depending on UE capabilities	
8	2 DPCH	One or more DCH coded into a single CCTrCH	Mandatory	The maximum number of DCH and the maximum channel bit rate are dependent on UE radio access capabilities This channel is used as reference measurement channel
9	One or more DPCH	One or more DCH coded into one or more CCTrCH	Depending on UE radio access capabilities	The maximum number of DCHs, the maximum number of CCTrCH and the maximum channel bit rate are dependent on UE radio access capabilities.
10	FPACH + one or more DPCH	One or more DCH coded into one or more CCTrCH	Depending on UE radio access capabilities	FPACH is used to answer the UE and to adjust the timing and synchronization shift of the UE. The maximum number of DCHs, the maximum number of CCTrCH and the maximum channel bit rate are dependent on UE radio access capabilities. This configuration is required for UE that operate shared channels and dedicated channels simultaneously.
11	One or more S-CCPCH + one or more DPCH	(One or more FACH or/and PCH) + one or more DCH coded into one or more CCTrCH	Depending on UE radio access capabilities	The maximum number of DCHs, the maximum number of CCTrCH and the maximum channel bit rate are dependent on UE radio access capabilities. This configuration is required for UE that operate shared channels and dedicated channels simultaneously.

	Physical Channel Combination	Transport Channel Combination	Mandatory or dependent on UE radio access capabilities	Comment
12	One or more PDSCH	One or more DSCH coded onto one or more CCTrCH	Depending on UE radio access capabilities	This configuration is required for UE that operate shared channels.
13	FPACH + one or more PDSCH	One or more DSCH coded onto one or more CCTrCH	Depending on UE radio access capabilities	This configuration is desirable but not essential for UE supporting shared channels.
14	One or more S-CCPCH + one or more PDSCH	(One or more FACH and/or PCH) + One or more DSCH coded onto one or more CCTrCH	Depending on UE radio access capabilities	This configuration is desirable but not essential for UE supporting shared channels.
15	One or more PDSCH + one or more DPCH	One or more DSCH coded onto one or more CCTrCH + one or more DCH coded into one or more CCTrCH	Depending on UE radio access capabilities	This configuration is required for UE that operate shared channels and dedicated channels simultaneously.

	Physical Channel Combination	Transport Channel Combination	Mandatory or dependent on UE radio access capabilities	Comment
16	FPACH + one or more PDSCH + one or more DPCH	one or more DSCH coded onto one or more CCTrCH + one or more DCH coded into one or more CCTrCH	Depending on UE radio access capabilities.	FPACH is used to answer the UE and to adjust the timing and synchronization shift of the UE. This configuration is desirable but not essential for UE supporting shared channels and dedicated channels simultaneously.
17	One or more S-CCPCH + one or more PDSCH + one or more DPCH	(One or more FACH and/or PCH) + one or more DSCH coded onto one or more CCTrCH + one or more DCH coded into one or more CCTrCH	Depending on UE radio access capabilities.	This configuration is desirable but not essential for UE supporting shared channels and dedicated channels simultaneously.
18	One or more DPCH + zero, one or more HS-PDSCH + one or more HS-SCCH	One or more DCH coded into one or more CCTrCH + one or more HS-DSCH coded into one CCTrCH	Depending on UE radio access capabilities	
19	MICH	N/A	Depending on UE radio access capabilities	
20	MICH + PICH	N/A	Depending on UE radio access capabilities	
21	MICH + one or more SCCPCH	One or more FACH + one or more PCH + (NOTE 1)	Depending on UE radio access capabilities	Allowing MBMS notification indication during reception of non-MBMS FACH or PCH.
22	PICH + one or more SCCPCH	One or more FACH + (NOTE 1)	Depending on UE radio access capabilities	The maximum number of SCCPCHs and the maximum bit rate depend on the UE implementation.
23	MICH + PICH + one or more SCCPCH	One or more FACH + (NOTE 1)	Depending on UE radio access capabilities	The maximum number of SCCPCHs and the maximum bit rate depend on the UE implementation.
24	FPACH +Zero, one or more DPCH + zero, one or more HS-PDSCH + one or more HS-SCCH + zero, one or more E-AGCH + zero or one E.HICH	Zero, one or more DCHs coded into zero, one or more CCTrCH + one HS-DSCH	Depending on UE radio access capabilities	The maximum number of SCCPCHs and the maximum bit rate depend on the UE implementation.

	Physical Channel Combination	Transport Channel Combination	Mandatory or dependent on UE radio access capabilities	Comment
25	P-CCPCH + one or more HS-SCCH + zero, one or more HS-PDSCH + S-CCPCH	BCH + one HS-DSCH + one or more FACH	Depending on UE radio access capabilities	Simultaneous reception of P-CCPCH, S-CCPCH and HS-SCCH is only needed at occurrences when the UE needs to read system information on BCH while being in CELL_FACH state, i.e. continuous reception of P-CCPCH, and S-CCPCH and HS-SCCH at the same time is not required. S-CCPCH and HS-SCCH are to be detected at the same time. One HS-DSCH is used in CELL_FACH state to enable the reception of CCCH, BCCH, DCCH and DTCH logical channel data. The reception of one or more FACH is to enable the reception of broadcast services on the CTCH, mapped to one of the FACH. The requirement holds for P-CCPCH, S-CCPCH and HS-SCCH sent in different cells or in the same cell.
26	One or more HS-SCCHs + zero, one or more HS-PDSCH	One HS-DSCH	Depending on UE radio access capabilities	One HS-DSCH is used in CELL_FACH state to enable the reception of CCCH, BCCH, DCCH and DTCH logical channel data.
27	One or more HS-SCCHs + zero, one or more HS-PDSCH + more than one SCCPCH	One HS-DSCH + one or more FACH	Depending on UE radio access capabilities	One HS-DSCH is used in CELL_FACH state to enable the reception of CCCH, DCCH and DTCH logical channel data. In CELL_FACH state the reception of (one or more FACH) is to enable the reception of broadcast services on the CTCH, mapped to one of the FACH. One or more FACHs are used to enable the reception of MBMS (i.e., MCCH, MSCH and MTCH). The maximum number of S-CCPCHs and the maximum bit rate depend on the UE implementation. The combination includes the case where one or more MBMS FACHs are transmitted on the same S-CCPCH as used for non-MBMS FACH.
28	MICH + one or more HS-SCCH + zero, one or more HS-PDSCH + S-CCPCH	One HS-DSCH	Depending on UE radio access capabilities	Allowing reception of MBMS notification indication during reception of HS-DSCH in CELL_FACH state.
NOTE 1: + (zero, one or more DCH coded onto one or more CTrCh) + (zero, one or more DSCH coded onto one or more CTrCh) + (zero, one or more HS-DSCH coded onto one or more CTrCh).				

The table 6-2 describes the possible combinations of 1.28Mcps TDD physical channels that can be supported in the downlink on two or more configured downlink frequencies by one UE simultaneously.

Table 6-2: 1.28 Mcps TDD Downlink for Multi-carrier HS-DSCH

Physical Channel Combination	Physical Channel Combination on Primary HS-DSCH carrier	Physical Channel Combination on Additional HS-DSCH carrier	Mandatory or dependent on UE radio access capabilities	Comment
1	Zero or one DPCH + zero, one or more HS-PDSCH + HS-SCCH + E-AGCH + E-HICH	zero, one or more HS-PDSCH + HS-SCCH + E-AGCH + E-HICH	Depending on UE radio access capabilities	The maximum number of HS-DSCHs and the maximum channel bit rate are dependent on UE radio access capabilities. In this combination E-DCH(s) are configured on each corresponding uplink frequency.

8.4.3 3.84 Mcps TDD IMB Downlink

The table describes the possible combinations of 3.84 Mcps TDD IMB physical channels that can be supported in the downlink on the same frequency by one UE simultaneously.

Table 6a: 3.84 Mcps TDD IMB Downlink

	Physical Channel Combination	Transport Channel Combination	Mandatory or dependent on UE radio access capabilities	Comment
1	PCCPCH	BCH	Mandatory	
2	SCCPCH	FACH	Mandatory	
3	SCCPCH frame type 2	One or more FACH	Mandatory	The maximum channel bit rate that can be supported is dependent on the UE radio access capabilities.
4	SCCPCH + SCCPCH frame type 2	More than one FACH	Mandatory	One or more FACHs are used to enable the reception of MBMS (i.e., MCCH and MTCH). The maximum number of SCCPCHs and the maximum bit rate depend on the UE implementation.
5	More than one SCCPCH frame type 2	More than one FACH	Depending on UE radio access capabilities	
6	MICH	N/A	Depending on UE radio access capabilities	
7	MICH + SCCPCH	FACH	Depending on UE radio access capabilities	Allowing MBMS notification indication during reception of MBMS FACH.
8	MICH+ SCCPCH frame type 2	One or more FACH	Depending on UE radio access capabilities	Allowing MBMS notification indication during reception of MBMS FACH.
9	MICH + SCCPCH+ SCCPCH frame type 2	More than one FACH	Depending on UE radio access capabilities	Allowing MBMS notification indication during reception of MBMS FACH.

9 Measurements provided by the physical layer

One of the key services provided by the physical layer is the measurement of various quantities, which are used to trigger or perform a multitude of functions. Both the UE and the UTRAN are required to perform a variety of measurements. The standard will not specify the method to perform these measurements or stipulate that the list of measurements provided in this clause must all be performed. While some of the measurements are critical to the functioning of the network and are mandatory for delivering the basic functionality (e.g., handover measurements,

power control measurements), others may be used by the network operators in optimising the network (e.g., radio environment).

Measurements may be made periodically and reported to the upper layers or may be event-triggered (e.g., primary CCPCH becomes better than the previous best primary CCPCH). Another reporting strategy may combine the event triggered and the periodical approach (e.g. falling of link quality below a certain threshold initiates periodical reporting). The measurements are tightly coupled with the service primitives in that the primitives' parameters may constitute some of the measurements.

The list and frequency of measurements, which the physical layer reports to higher layers, is described in this clause. The detailed definition of measurement control and abilities is contained in [6] for FDD and [11] for TDD. The measurement performance requirements together with accuracy, range and mapping is specified in [9] for TDD and in [10] for FDD.

The measurement quantities measured by the physical layer shall be such that the following principles are applied:

- for handover measurements, the decoding of parameters on the BCCH logical channel of monitored neighbouring cells, should not, in general, be needed for calculating the measurement result. If there is a need to adjust the measurement result with parameters broadcast on the PCCPCH, these parameters shall be provided by the UTRAN in inband measurement control messages. There may be some exceptions to this rule;

EXAMPLE:

It may be necessary to decode the SFN of the measured neighbouring cell for time difference measurements.

- in idle mode or in RRC connected mode using common Transport Channels, the UE shall be able to monitor cells for cell reselection, without being required to frequently decode parameters on the BCCH logical channel of the monitored neighbouring cells. The decoding frequency of these parameters, set by the cell reselection algorithm, should be such that UE standby times are not significantly decreased.

9.1 Model of physical layer measurements

This subclause describes a model for how the physical layer measurements are performed. This model applies both to the UE and Node B measurements. This model sets the requirement on the behaviour of the measurement elaboration and reporting performed by L1 as well as filtering controlled by higher layers. It is not meant to be a requirement for implementation as long as the performance requirements in [9] and [10] are fulfilled.

The measurement model for physical layer measurements is represented in the figure 7.

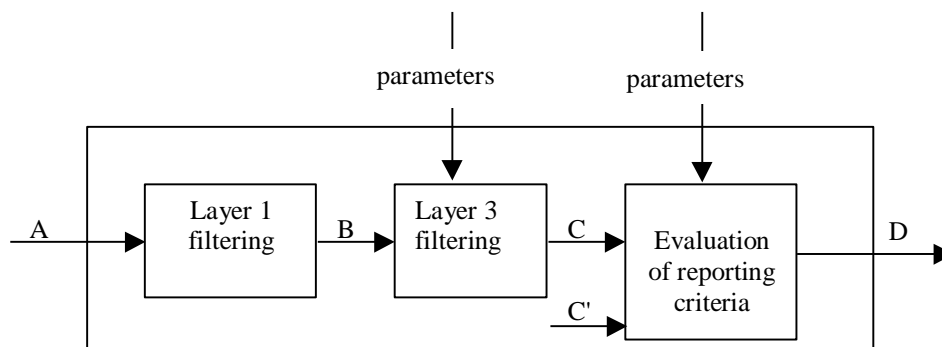

Figure 7: Measurement model

The model is described below:

- **A:** measurements (samples) internal to the physical layer in support to the measurements to be provided to higher layers;
- **Layer 1 filtering:** internal layer 1 filtering of the inputs measured at point A. Exact filtering is implementation dependant. How the measurements are actually executed in the physical layer by an implementation (in puts A and Layer 1 filtering) in not constrained by the standard i.e. the model does not state a specific sampling rate or even if the sampling is periodic or not. What the standard specifies in [9] and [10] is the performance objective

and measurement period at point B in the model. The performance objectives for the physical layer measurements are specified in [9] and [10];

- **B:** A measurement reported by layer 1 after layer 1 filtering. The reporting rate at point B shall be sufficient to meet the performance objectives as defined in [9] and [10];
- **Layer 3 filtering:** Filtering performed on the measurements provided at point B. The behaviour of the Layer 3 filters are standardised and the configuration of the layer 3 filters is provided by RRC signalling (UE measurements) or NBAP signalling (Node B measurements). Each filtered result at point C shall correspond to a Layer 3 filtering performed using a reporting period equal to one measurement period at point B;
- **C:** A measurement after processing in the layer 3 filter. The reporting rate is identical to the reporting rate at point B and is therefore also measurement type specific. Although this is not shown in the figure, one measurement can be used by a multiplicity of evaluation of reporting criteria;
- **Evaluation of reporting criteria:** This checks whether actual measurement reporting is necessary at point D i.e. whether a message need to be sent to higher layers on the radio interface or Iub interface. The evaluation can be based on more than one flow of measurements at reference point C e.g. to compare between different measurements. This is illustrated by input C, C', etc. The UE shall evaluate the reporting criteria at least every time a new measurement result is reported at point C, C' etc. The reporting criteria are standardised and the configuration is provided by RRC signalling (UE measurements) or NBAP signalling (Node B measurements). Examples are periodic reporting and event based reporting. In case periodical reporting is in use and if the reporting interval is different from the filtering period defined by the layer 3 filter, the last measurement result filtered by the L3 filter shall be used as the value of the reported result. In case event triggered reporting is in use and the reporting criteria is fulfilled, the last measurement result filtered by the L3 filter shall be used as the value for reporting criteria evaluation and as the value of the reported result. This applies also for any additional measurements that shall be reported as a consequence of the event;
- **D:** a measurement report information (message) sent on the radio or Iub interface.

9.2 UE Measurements

For definitions of the measurements, see [6] and [11].

9.2.1 SFN-CFN observed time difference

This measure is mandatory for UE.

Measurement	SFN-CFN observed time difference
Source	L1 (UE)
Destination	RRC (RNC) for handover
Reporting Trigger	On-demand, Event-triggered
Description	Time difference between the SFN of the target neighbouring cell and the CFN in the UE.

9.2.2 Void

9.2.3 CPICH E_c/N_0

This measure is mandatory for UE with FDD mode capability.

Measurement	CPICH E_c/N_0
Source	L1(UE)
Destination	RRC (UE, RNC)
Reporting Trigger	Periodic, on demand and event triggered
Description	The received energy per chip of the CPICH divided by the power density in the frequency band.

9.2.4 Void

9.2.5 CPICH RSCP

This measure is mandatory for UE with FDD mode capability.

Measurement	CPICH RSCP
Source	L1(UE)
Destination	RRC (UE, RNC)
Reporting Trigger	periodic or event triggered
Description	Received signal code power of the CPICH.

9.2.6 P-CCPCH RSCP

This measure is mandatory for UE with TDD mode capability.

Measurement	P-CCPCH RSCP
Source	L1(UE)
Destination	RRC (UE, RNC)
Reporting Trigger	periodic or event triggered
Description	Received signal code power of the P-CCPCH

9.2.7 Timeslot ISCP

This measure is mandatory for UE with TDD mode capability.

Measurement	Timeslot ISCP
Source	L1(UE)
Destination	RRC (UE, RNC)
Reporting Trigger	periodic or event triggered
Description	Interference Signal Code Power is the interference on the received signal in a specified timeslot.

9.2.8 Void

9.2.9 SIR

This measure is mandatory for UE with TDD mode capability.

Measurement	SIR
Source	L1(UE)
Destination	RRC (UE,RNC)
Reporting Trigger	Periodic, once every power control cycle , event triggered
Description	Signal to Interference Ratio

9.2.10 UTRA carrier RSSI

This measure is mandatory for UE.

Measurement	UTRA carrier RSSI
Source	L1(UE)
Destination	RRC (RNC)
Reporting Trigger	Periodic, event triggered, on demand
Description	Received Signal Strength Indicator, the wideband received power within the relevant channel bandwidth. For TDD this is measured in specified timeslots.

9.2.11 GSM carrier RSSI

This measure is mandatory for UE with GSM capability.

Measurement	GSM carrier RSSI
Source	L1(UE)
Destination	RRC (RNC)
Reporting Trigger	Periodic, event triggered, on demand
Description	Received Signal Strength Indicator, the wide-band received power within the relevant channel bandwidth. Details are specified in the GSM specification 05.08

9.2.12 Transport channel BLER

This measure is mandatory for UE.

Measurement	Transport channel BLER (BLock Error Rate)
Source	L1(UE)
Destination	RRC (RNC,UE)
Reporting Trigger	Periodic, on demand
Description	Estimation of the transport channel block error rate (BLER).

9.2.13 UE transmitted power

This measure is mandatory for UE.

Measurement	UE transmitted power
Source	L1(UE)
Destination	RRC (UE,RNC)
Reporting Trigger	On-demand, periodic, Event-triggered
Description	Sum of the total UE transmitted power on all configured uplink carriers. For TDD this is measured in specified timeslots.

9.2.14 UE Rx-Tx time difference

This measure is mandatory for UE with FDD mode capability.

Measurement	UE Rx-Tx time difference
Source	L1 (UE)
Destination	RRC (RNC)
Reporting Trigger	On-demand, periodic, event-triggered
Description	Time difference between the UE uplink DPCCH/DPDCH frame transmission and the first detected path (in time) of the downlink DPCH or F-DPCH frame from the measured radio link. Type 1 and Type 2 are defined.

9.2.15 SFN-SFN Observed time difference

This measure is mandatory for UE.

Measurement	SFN-SFN observed time difference
Source	L1 (UE)
Destination	RRC (RNC)
Reporting Trigger	On-demand, Event-triggered
Description	Time difference between a specific reference UTRA cell and a target UTRA cell. Type 1 and Type 2 are defined.

9.2.16 UE GPS Timing of Cell Frames for UE positioning

This measure is mandatory for UE that has the capability to measure GPS reference time.

Measurement	UE GPS Timing of Cell Frames for UE positioning
Source	L1 (UE)
Destination	RRC (RNC-UE positioning)
Reporting Trigger	On-demand, Event-triggered, Periodic
Description	The timing between UTRA cell and GPS Time Of Week.

9.2.17 Timing Advance (T_{ADV}) for 1.28 Mcps TDD

This measure is mandatory for 1.28 Mcps TDD UE.

Measurement	Timing Advance (T_{ADV}) for 1.28 Mcps TDD
Source	L1 (UE)
Destination	RRC (RNC)
Reporting Trigger	On-demand, Event-triggered, Periodic
Description	Difference between the uplink transmission of the UE and the downlink reception.

9.2.18 UE GPS code phase

This measure is mandatory for UE with UE-assisted GPS capability.

NOTE: The UE transmits the GPS code phase in the IE "Whole GPS Chips" and in the IE "Fractional GPS Chips" defined in [13].

Measurement	UE GPS code phase
Source	L1 (UE)
Destination	RRC (RNC)
Reporting Trigger	On-demand, Event-triggered, Periodic
Description	The whole and fractional phase of the spreading code of the GPS satellite signal.

9.2.19 UE GANSS Timing of Cell Frames for UE positioning

This measure is mandatory for UE that has the capability to measure GANSS reference time for a given GANSS system and signal.

Measurement	UE GANSS Timing of Cell Frames for UE positioning
Source	L1 (UE)
Destination	RRC (RNC-UE positioning)
Reporting Trigger	On-demand, Event-triggered, Periodic
Description	The timing between UTRA cell and GANSS Time of Day.

9.2.20 UE GANSS code measurement

This measure is mandatory for UE with UE-assisted GANSS capability.

NOTE: The UE transmits the GANSS code phase in the IE "GANSS Code Phase" and in the IE "GANSS Integer Code Phase" defined in [13].

Measurement	UE GANSS code phase
Source	L1 (UE)
Destination	RRC (RNC)
Reporting Trigger	On-demand, Event-triggered, Periodic
Description	The code phase and optionally the Integer code phase of the spreading code of the GANSS satellite signal.

9.2.21 UE transmission power headroom

This measure is mandatory for UE with FDD mode capability.

Measurement	UE transmission power headroom
Source	L1(UE)
Destination	MAC (UE,Node B)
Reporting Trigger	Periodic, Event-triggered
Description	For each uplink DPCCCH, the ratio of the maximum UE transmission power and the DPCCCH code power.

9.3 UTRAN Measurements

9.3.1 Received total wide band power

Measurement	Received total wide band power
Source	L1 (Node B)
Destination	RRC(RNC)
Reporting Trigger	On-demand, Event-triggered, Periodic
Description	The received wide band power including noise generated in the receiver, within the bandwidth defined by the pulse shaping filter. For TDD mode, this is measured in specified timeslots.

9.3.2 Transmitted carrier power

Measurement	Transmitted carrier power
Source	L1(Node B)
Destination	RRC (RNC)
Reporting Trigger	On-demand, periodic, Event-triggered
Description	Transmitted carrier power is the ratio between the total transmitted power on one DL carrier from one UTRAN access point, compared to the maximum power possible to use on that DL carrier at this moment of time. For TDD mode, this is measured in specified timeslots.

9.3.3 Transmitted code power

Measurement	Transmitted code power
Source	L1(Node B)
Destination	RRC (RNC)
Reporting Trigger	On-demand, periodic, Event-triggered
Description	Transmitted Code Power is the transmitted power on one carrier, one scrambling and one channelisation code. For TDD mode, this is measured in specified timeslots.

9.3.4 Void

9.3.5 Physical channel BER

Measurement	Physical channel BER
Source	L1(Node B)
Destination	RRC (RNC)
Reporting Trigger	On-demand, Event-triggered, periodic
Description	The Physical channel BER is an estimation of the average bit error rate (BER) on the DPCCCH of a Radio Link Set. This measurement applies to FDD mode only.

9.3.6 Transport channel BER

Measurement	Transport channel BER
Source	L1(Node B)
Destination	RRC (RNC)
Reporting Trigger	On-demand, Event-triggered, periodic
Description	The transport channel BER is an estimation of the average bit error rate (BER) data part.

9.3.7 RX timing deviation

Measurement	RX timing deviation
Source	L1 (Node B)
Destination	RRC (RNC)
Reporting Trigger	Periodic, event triggered
Description	The difference of the time of arrival of the UL transmissions in relation to the arrival time of a signal with zero propagation delay. This measurement is applicable for TDD mode.

9.3.8 Timeslot ISCP

Measurement	Timeslot ISCP
Source	L1(Node B)
Destination	RRC (RNC)
Reporting Trigger	periodic or event triggered
Description	Interference on Signal Code Power, is the interference on the received signal in a specified timeslot. This measurement is applicable is applicable to TDD mode only.

9.3.9 RSCP

Measurement	RSCP
Source	L1(Node B)
Destination	RRC (RNC)
Reporting Trigger	periodic or event triggered
Description	Received Signal Code Power is the received power on DPCH or PRACH, PUSCH or HS-SICH. This measurement is applicable for TDD mode only.

9.3.10 Round Trip Time

Measurement	Round Trip Time
Source	L1(Node B or LMU)
Destination	RRC (RNC-UE positioning)
Reporting Trigger	on demand, event triggered
Description	This is an estimate of the round trip time of signals between the Node B and the UE This measurement is applicable for FDD mode only.

9.3.11 Void

9.3.12 Acknowledged PRACH preambles

Measurement	Acknowledged PRACH preambles
Source	L1(Node B)
Destination	RRC (RNC)
Reporting Trigger	Periodic, event triggered, On demand
Description	This measurement indicates the number of positive acquisition indicators used to allow transmission on the PRACH message part transmitted per access frame on each AICH. This measurement is applicable for FDD mode only.

9.3.13 Void

9.3.14 Void

9.3.15 SIR

Measurement	SIR
Source	L1(Node B)
Destination	RRC (RNC)
Reporting Trigger	Periodic, event triggered
Description	Signal to Interference Ratio.

9.3.16 PRACH Propagation Delay

Measurement	Propagation delay
Source	L1 (Node B)
Destination	RRC (RNC)
Reporting Trigger	Event triggered, periodic
Description	The one-way propagation delay as measured during PRACH access. This measurement is applicable for FDD mode only.

9.3.17 UTRAN GPS Timing of Cell Frames for UE positioning

Measurement	UTRAN GPS Timing of Cell Frames for UE positioning
Source	L1 (LMU)
Destination	RRC (RNC-UE positioning)
Reporting Trigger	On-demand, Event-triggered, Periodic
Description	This is the absolute time reference measurement in respect to GPS Time Of Week for the transmission of a particular frame.

9.3.18 SIR ERROR

Measurement	SIR ERROR
Source	L1(Node B)
Destination	RRC (RNC)
Reporting Trigger	Periodic, event triggered
Description	Signal to Interference Ratio Error This measurement is applicable for FDD cells only.

9.3.19 Received SYNC_UL Timing Deviation

Measurement	Received SYNC_UL Timing Deviation
Source	L1 (Node B)
Destination	RRC (RNC)
Reporting Trigger	Event triggered
Definition	'Received SYNC_UL Timing Deviation' is the time difference $UpPCH_{POS} = UpPTS_{R_{path}} - UpPTS_{TS}$ Where $UpPTS_{R_{path}}$: time of the reception in the Node B of the SYNC_UL to be used in the uplink synchronization process $UpPTS_{TS}$: time instance two symbols prior to the end of the DwPCH according to the Node B internal timing

9.3.20 Cell Sync Burst Timing

Measurement	Cell Sync Burst Timing
Source	L1(Node B)
Destination	RRC (RNC)
Reporting Trigger	Periodic, event triggered
Definition	Cell sync burst timing is the time of start (defined by the first detected path in time) of the cell sync burst of a neighbouring cell. Type 1 is used for the initial phase of Node B synchronization. Type 2 is used for the steady-state phase of Node B synchronization.

9.3.21 Cell Sync Burst SIR

Measurement	Cell Sync Burst SIR
Source	L1(Node B)
Destination	RRC (RNC)
Reporting Trigger	Periodic, event triggered
Definition	Signal to Interference Ratio for the cell sync burst, defined as: $RSCP/Interference$, where:

9.3.22 SFN-SFN Observed time difference

Measurement	SFN-SFN observed time difference
Source	L1 (LMU)
Destination	RRC (RNC-UE positioning)
Reporting Trigger	On-demand, Periodic, On Modification
Description	Measured time between reception of signal from a specific reference UTRA cell and from a neighbour UTRA cell.

9.3.23 Angle of Arrival (AOA) for 1.28 Mcps TDD

Measurement	Angle of Arrival (AOA) for 1.28Mcps TDD
Source	L1 (Node B)
Destination	RRC (RNC)
Reporting Trigger	Event-triggered, on-demand
Description	AOA defines the estimated angle of a user with respect to a reference direction. The reference direction for this measurement shall be the North, positive in a counter-clockwise direction. The AOA is determined at the UTRAN access point antenna for an UL channel corresponding to this UE.

9.3.24 HS-SICH reception quality

Measurement	HS-SICH reception quality
Source	L1 (Node B)
Destination	RRC (RNC)
Reporting Trigger	On-demand, Event-triggered, Periodic
Description	The HS-SICH reception quality is defined via the the number of expected HS-SICH transmissions from a given UE and the number of unsuccessful HS-SICH receptions for this same UE in the Node B. For 1.28 Mcps TDD, only measurements made on HS-SICH transmissions that were transmitted using open loop power control are reported as part of this measurement. This measurement is applicable for TDD cells only.

9.3.25 Transmitted carrier power of all codes not used for HS-PDSCH, HS-SCCH, E-AGCH, E-RGCH or E-HICH transmission

Measurement	Transmitted carrier power of all codes not used for HS-PDSCH, HS-SCCH, E-AGCH, E-RGCH or E-HICH transmission
Source	L1 (Node B)
Destination	RRC (RNC)
Reporting Trigger	On-demand, periodic, Event-triggered
Description	<p>Transmitted carrier power of all codes not used for HS-PDSCH, HS-SCCH, E-AGCH, E-RGCH or E-HICH transmission is the ratio between the total transmitted power of all codes not used for HS-PDSCH, HS-SCCH, E-AGCH, E-RGCH or E-HICH transmission on one DL carrier from one UTRAN access point, and the maximum transmission power possible to use on that DL carrier at this moment of time.</p> <p>For TDD mode, this is measured in specified timeslots.</p>

9.3.26 UpPTS interference (1.28Mcps TDD)

Measurement	UpPTS interference (1.28Mcps TDD)
Source	L1 (Node B)
Destination	RRC (RNC)
Reporting Trigger	On-demand, periodic, Event-triggered
Description	<p>The level of interference in the UpPTS is the difference between the mean received power in the UpPTS and the sum of the estimated mean power levels of all detected UpPCH transmissions. In the case of antenna diversity, the linear average of the UpPTS interference levels for each antenna branch shall be calculated. The reference point for the UpPTS interference measurement shall be the Rx antenna connector.</p>

9.3.27 DL Transmission Branch Load

Measurement	DL Transmission Branch Load
Source	L1(Node B)
Destination	RRC (RNC)
Reporting Trigger	On-demand, Event-triggered, Periodic
Description	<p>The 'DL transmission branch load' is the maximum of the transmission branch loads calculated for each branch.</p> <p>A 'transmission branch load' is the ratio between the total transmitted power [W] on the considered branch and the 'maximum DL branch capability' on this branch.</p> <p>The 'maximum DL branch capability' defines the maximum transmission power possible to use on that branch.</p> <p>The reference point for the transmission branch load measurement shall be the TX antenna connector.</p>

9.3.28 Received scheduled E-DCH power share (RSEPS)

Measurement	Received scheduled E-DCH power share (RSEPS)
Source	L1 (Node B)
Destination	RRC(RNC)
Reporting Trigger	On-demand, Event-triggered, Periodic
Description	<p>The 'Received scheduled E-DCH power share' is defined as a report of 2 values for a considered cell:</p> <ol style="list-style-type: none"> 1. RSEPS: defined as a quotient: sum of all scheduled E-DPDCH and corresponding E-DPCCH power contributions determined in the RSEPS measurement period $T=t_2-t_1>0$ for all UEs for which this cell is the serving E-DCH cell divided by the corresponding total received wideband power value determined for this cell during T. 2. RTWP*: This is the received total wideband power (RTWP) measured for this cell as defined in section 9.3.1 but determined for the same time period T starting at t1 and ending at t2 during which RSEPS is determined. <p>If the E-DPCCH can but the E-DPDCH transport block can not be decoded successfully even from subsequent retransmissions, it is considered as scheduled transmission. The reference point for the RSEPS and RTWP* measurements shall be the Rx antenna connector. When cell portions are defined in the cell, RSEPS (and RTWP*) shall be measured for each cell portion.</p> <p>This measurement applies to FDD mode only.</p>

9.3.29 UTRAN GANSS Timing of Cell Frames for UE positioning

Measurement	UTRAN GANSS Timing of Cell Frames for UE positioning
Source	L1 (LMU)
Destination	RRC (RNC-UE positioning)
Reporting Trigger	On-demand, Event-triggered, Periodic
Description	This is the absolute time reference measurement in respect to GANSS Time Of Day for the transmission of a particular frame. This is provided in a specific GANSS system time.

9.3.30 Common E-DCH resource usage

Measurement	Common E-DCH resource usage
Source	L1(Node B)
Destination	RRC (RNC)
Reporting Trigger	Periodic, event triggered, On demand
Description	<p>This measurement pertains only to the case where Enhanced Uplink in CELL_FACH state and Idle mode is enabled in the considered cell. This measurement is applicable for FDD mode only. The 'Common E-DCH resource usage' is defined as a report of 5 values for a considered cell:</p> <ol style="list-style-type: none"> 1. Granted E-DCH Resources: defined as the number of common E-DCH resources that have been granted per access frame on each AICH. In case Concurrent deployment of 2ms and 10ms TTI is configured in a cell, it is defined as the number of 10ms TTI common E-DCH resources that have been granted per access frame on each AICH for the UEs that request for 10ms TTI common E-DCH resource. 2. Denied E-DCH Resources: defined as the number of PRACH preambles received at the NodeB that were not granted a common E-DCH resource. In case Concurrent deployment of 2ms and 10ms TTI is configured in a cell, it is defined as the number of PRACH preambles received at the NodeB that were not granted a 10ms TTI common E-DCH resource for the UEs that requested for 10ms TTI common E-DCH resource. 3. 2ms Granted E-DCH RACH Resources: defined as the number of 2ms TTI common E-DCH resources that have been granted per access frame on each AICH in case Concurrent deployment of 2ms and 10ms TTI is configured in a cell. 4. 2ms Overridden E-DCH RACH Resources: defined as the number of 10ms TTI common E-DCH resources that have been granted per access frame on each AICH for the UEs that request for 2ms TTI but are granted 10ms TTI common E-DCH resources in case Concurrent deployment of 2ms and 10ms TTI is configured in a cell. 5. 2ms Denied E-DCH RACH Resources: defined as the number of PRACH preambles received at the NodeB that are granted neither a 2ms nor 10ms TTI common E-DCH resource for the UEs that request for 2ms TTI common E-DCH resource in case of Concurrent deployment of 2ms and 10ms TTI is configured in a cell.

10 Primitives of the physical layer

The Physical layer interacts with other entities as illustrated in figure 1. The interactions with the MAC layer and the RRC layer are shown in terms of primitives where the primitives represent the logical exchange of information and control between the physical layer and higher layers. They do not specify or constrain implementations. The (adjacent) layers connect to each other through Service Access Points (SAPs). Primitives, therefore, are the conveyers of the information exchange and control through SAPs.

Four types of primitives are used for the present document, as follows.

- **REQUEST (REQ):**
 - This type is used when a higher layer is requesting a service from a lower layer.
- **INDICATION (IND):**
 - This type is used by a lower layer providing a service to notify its higher layer of activities concerning that higher layer.
- **RESPONSE (RESP):**
 - This type is used by a higher layer providing the indicated service to respond to its lower layer that the activity has been completed.
- **CONFIRM (CNF):**

- This type is used by a lower layer providing the requested service to confirm to the higher layer that the activity has been completed.

The primitives defined below are for local communications between MAC and L1, as well as RRC and L1 in the same protocol stack.

For the physical layer two sets of primitives are defined:

- **Primitives between layer 1 and 2:**
 - PHY - Generic name - Type: Parameters.
- **Primitives between layer 1 and the RRC entity:**
 - CPHY - Generic name - Type: Parameters.

NOTE: This is a logical description of the primitives and does not cover addressing aspects (e.g. Transport Channel ID, Physical Channel ID, start frame number or disconnect frame number).

10.1 Generic names of primitives between layers 1 and 2

The primitives between layer 1 and layer 2 are shown in table 7.

Table 7: Primitives between layer 1 and 2

Generic Name	Parameter			
	REQ	IND	RESP	CNF
PHY-Access	Transport Format subset (1), ASC selected for Transport Block Set to be transmitted (5) Random Access Type (9), Random access for common E-DCH transmission (1)	Not Defined	Not Defined	access information (1)
PHY-Data	TFI, E-TFI (8), Transport Block Set, CFN _{CELL} , TTI within CFN (7), Paging Indicators (2), ASC selected for that Transport Block Set (3), HS-DSCH information (6), E-DCH information (8)	TFI, E-TFI (8) Transport Block Set, CRC check result, TD (4), HARQ process (7)	Not Defined	Not Defined
PHY-Status	HARQ status (7)	Event value, HS-DSCH Feedback information (7)	Not Defined	Not Defined

NOTE (1): FDD only.
NOTE (2): PCH only
NOTE (3): 3.84/7.68 Mcps TDD RACH only
NOTE (4): optional, TDD only
NOTE (5): FDD RACH, and 1.28 Mcps TDD RACH and E-DCH access only
NOTE (6): HS-DSCH only
NOTE (7): HS-DSCH and E-DCH only
NOTE (8): E-DCH only
NOTE (9): 1.28 Mcps TDD only

10.1.1 PHY-Access-REQ

The PHY-Access-REQ primitive is used to request access to either a RACH transport channel from the physical layer. A PHY-Access primitive is submitted once before the actual data for peer-to-peer communication is passed to the physical layer using the PHY-Data primitive. This primitive is used in FDD and 1.28 Mcps TDD only.

In FDD, the PHY-Access-REQ primitive is also used to request the physical layer to access a common E-DCH transport channel. A PHY-Access-REQ primitive is submitted before the actual data for peer-to-peer communication is passed to the physical layer.

Parameters:

- Transport Format subset.
- ASC selected for Transport Block Set to be transmitted (FDD RACH, FDD common E-DCH and 1.28 Mcps TDD RACH and E-DCH access only)
- Random Access Type (1.28 Mcps TDD only)
- Random access for common E-DCH transmission (FDD only for common E-DCH)

10.1.2 PHY-Access-CNF

The PHY-Access-CNF primitive is used to confirm that physical layer synchronisation has been established and that the physical layer is ready for data transmission using the PHY-Data primitive. This primitive is used in FDD and 1.28 Mcps TDD only.

Parameters:

- access information.

10.1.3 PHY-Data-REQ

The PHY-Data primitives are used to request SDUs used for communications passed to and from the physical layer. One PHY-Data primitive is submitted every Transmission Time Interval for each Transport Channel.

Parameters:

- TFI;
- E-TFI (E-DCH only);
- HARQ Process (TDD E-DCH only);
- Transport Block Set;
- CFN_{CELL} ;
- TTI within CFN (HS-DSCH and FDD E-DCH (2ms TTI) only);
- Page Indicators (PIs) (PCH only);
- HS-DSCH information (HS-DSCH information);
- E-DCH information (E-DCH information);
- ASC selected for that Transport Block Set (3.84/7.68 Mcps TDD RACH only);
- Random access type (1.28 Mcps TDD RACH only).

10.1.4 PHY-Data-IND

The PHY-Data primitives are used to indicate SDUs used for Layer 2 passed to and from the physical layer. One PHY-Data primitive is submitted every Transmission Time Interval for each Transport Channel.

Parameters:

- TFI;
- E-TFI (E-DCH only);

- Transport Block Set;
- CRC check result;
- TD (RX Timing Deviation measurement) (optional, TDD only);
- Process Id (HS-DSCH and E-DCH only);
- Retransmission number (E-DCH only).

10.1.5 Void

10.1.6 Void

10.1.7 PHY-Status-IND

The PHY-Status-IND primitive can be used by the layer 1 to notify higher layers of an event that has occurred.

Parameters:

- Feedback information (HS-DSCH and E-DCH only);
- Event value:
 - L1 hardware failure has occurred.

10.2 Generic names of primitives between layers 1 and 3

The status primitives between layer 1 and 3 are shown in table 8.

Table 8: Status primitives between layer 1 and 3

Generic Name	Parameter			
	REQ	IND	RESP	CNF
CPHY-Sync	Not Defined	CCTrCH ID (1)	Not Defined	Not Defined
CPHY-Out-of-Sync	Not Defined	CCTrCH ID (1)	Not Defined	Not Defined
CPHY-Measurement	transmission power threshold, measurement parameters	measurement parameters	Not Defined	Not Defined
CPHY-Error	Not Defined	error code	Not Defined	Not Defined

NOTE (1): TDD only.

10.2.1 STATUS PRIMITIVES

10.2.1.1 CPHY-Sync-IND

This primitive is used for L1 to indicate to RRC that synchronisation of a certain physical channel has been done in the receiver. In FDD synchronisation is based on reception of the DPCCCH or F-DPCH, and in TDD synchronisation is based on Special Burst, TB reception, and DPCH burst quality estimation. For 3.84/7.68 Mcps TDD, when the UE is in cell_DCH state but no DL DPCH is configured the primitive is based on the methods specified in [5].

Parameters:

- CCTrCH ID (TDD only).

10.2.1.2 CPHY-Out-of-Sync-IND

Primitive sent from L1 to RRC indicating that synchronisation of a previously configured connection has been lost in the receiver. In FDD synchronisation is based on reception of the DPCCH or F-DPCH, and in TDD synchronisation is based on Special Burst, TB reception, and DPCH burst quality estimation. For 3.84 /7.68Mcps TDD, when the UE is in cell_DCH state but no DL DPCH is configured the primitive is based on the methods specified in [5].

Parameters:

- CCTrCH ID (TDD only).

10.2.1.3 CPHY-Measurement-REQ

The Request primitive is used for RRC to configure L1 measurements.

Parameters:

- transmission power threshold;
- refer to clause 9 for measurement parameters.

10.2.1.4 CPHY-Measurement-IND

The Indication primitive is used to report the measurement results.

Parameters:

- refer to clause 9 for measurement parameters.

10.2.1.5 CPHY-Error-IND

The CPHY-Error primitive is used to indicate to the management entity that an error has occurred as a result of a physical layer fault.

Parameters:

- error code.

10.2.1.6 Void

10.2.2 CONTROL PRIMITIVES

The control primitives between layer 1 and 3 are shown in table 9.

Table 9: Control primitives between layer 1 and 3

Generic Name	Parameter			
	REQ	IND	RESP	CNF
CPHY-TrCH-Config	transport channel description	Not Defined	Not Defined	No Parameter
CPHY-TrCH-Release	No Parameter	Not Defined	Not Defined	No Parameter
CPHY-RL-Setup	physical channel description	Not Defined	Not Defined	No Parameter
CPHY-RL-Release	No Parameter	Not Defined	Not Defined	No Parameter
CPHY-RL-Modify	physical channel description	Not Defined	Not Defined	No Parameter
CPHY-Commit	activation time	Not Defined	Not Defined	Not Defined
CPHY-Out-of-Sync-Config	Out of Sync detection parameters	Not Defined	Not Defined	No Parameter
CPHY-MBMS-Config	MBMS information	Not Defined	Not Defined	No Parameter

10.2.2.1 CPHY-TrCH-Config-REQ

This primitive is used for setting up and configuring a transport channel, and also to modify an existing transport channel.

Parameters:

- transport channel description.

10.2.2.2 CPHY-TrCH-Config-CNF

This primitive is used for confirming the setting up and configuring a transport channel, and also modifying an existing transport channel.

Parameters:

- No Parameter.

10.2.2.3 CPHY-TrCH-Release-REQ

This primitive is used for releasing a transport channel.

Parameters:

- No Parameter.

10.2.2.4 CPHY-TrCH-Release-CNF

This primitive is used for confirming the releasing a transport channel.

Parameters:

- No Parameter.

10.2.2.5 CPHY-RL-Setup-REQ

The Request primitive is sent from RRC to L1 for establishment of a Radio link to a certain UE.

Parameters:

- physical channel description.

10.2.2.6 CPHY-RL-Setup-CNF

The Confirm primitive is returned from L1 to RRC when the Radio link is established. In case L1 is unable to execute the request, this is indicated in the confirm primitive.

Parameters:

- No Parameter.

10.2.2.7 CPHY-RL-Release-REQ

The Request primitive is sent from RRC to L1 for release of a Radio link to a certain UE.

Parameters:

- No Parameter.

10.2.2.8 CPHY-RL-Release-CNF

The Confirm primitive is returned from L1 to RRC when the radio link is released.

Parameters:

- No Parameter.

10.2.2.9 CPHY- RL-Modify-REQ

The Request primitive is sent from RRC to L1 for modification of a Radio link to a certain UE.

Parameters:

- physical channel description.

10.2.2.10 CPHY-RL-Modify-CNF

The Confirm primitive is returned from L1 to RRC when the radio link is modified. In case L1 is unable to execute the request, this is indicated in the confirm primitive.

Parameters:

- No Parameter.

10.2.2.11 CPHY-Commit-REQ

This primitive is sent from RRC to L1 to synchronise UE and NW for the physical channel modification.

Parameters:

- activation time.

10.2.2.12 Void**10.2.2.13 Void****10.2.2.14 Void****10.2.2.15 Void****10.2.2.16 CPHY-Out-of-Sync-Config-REQ**

This primitive is sent from RRC to Node B L1 to reconfigure the parameters to detect "in sync" and "out of sync" conditions of uplink physical channel transmission.

Parameters:

- Out of Sync detection parameters

10.2.2.17 CPHY-Out-of-Sync-Config-CNF

This primitive is sent from Node B L1 to RRC for confirming the Reconfiguration of the Out-of-Sync parameters on Node B L1.

Parameters:

- No Parameter.

10.2.2.18 CPHY-MBMS-Config-REQ

This primitive is sent from UE RRC to L1 for the configuration of the MBMS information.

Parameters:

- MBMS information.

10.2.2.19 CPHY-MBMS-Config-CNF

This primitive is used to confirm the configuration of the MBMS information.

Parameters:

- No Parameter.

10.3 Parameter definition

10.3.1 Error code

- Hardware failure.

10.3.2 Event value

- Maximum transmission power has been reached.
- Allowable transmission power has been reached.
- Average transmission power is below allowable transmission power.
- Maximum number of retransmissions has been reached.
- Loss of DL DPCH.

10.3.3 Access Information

- Ready for RACH data transmission (in case of FDD mode: when Ack on AICH has been received and Random access for common E-DCH transmission was not included in the PHY-Access-REQ, in case of 1.28 Mcps TDD: when Ack on FPACH has been received);
- timeout, no response on AICH (FDD only) or FPACH (1.28 Mcps TDD only) has been received while maximum number of access preamble transmissions (FDD only) /synchronisation attempts (1.28 Mcps TDD only) has been performed.

The following value of this parameter apply to FDD only:

- NACK has been received carried with an AI, if the use of E-AIs is not configured, or carried with an E-AI, if the use of E-AIs is configured on AICH;
- E-DCH resource index received on AICH (when Ack carried with an AI has been received, or when Nack carried with an AI and no Nack carried with an E-AI has been received), if Random access for common E-DCH transmission was included in the PHY-Access-REQ.

10.3.4 Transport Format Subset

- A subset of the Transport Format set of a Transport Channel.

10.3.5 Physical channel description

10.3.5.1 Primary SCH

- Tx diversity mode.

10.3.5.2 Secondary SCH

- Tx diversity mode.

10.3.5.3 Primary CCPCH

- Frequency info.
- DL scrambling code.
- Tx diversity mode.
- Timeslot (TDD only).
- Burst type (3.84/7.68 Mcps TDD only).
- Offset (TDD only).
- Repetition period (TDD only).
- Repetition length (TDD only).

10.3.5.4 Secondary CCPCH

- DL scrambling code.
- Channelisation code.
- Tx diversity mode.
- Timeslot (TDD only).
- Burst type (3.84/7.68 Mcps TDD only).
- Midamble shift (TDD only).
- Offset (TDD only).
- Repetition period (TDD only).
- Repetition length (TDD only).
- TFCI presence (TDD only).
- MCCH modification period (only S-CCPCH carrying MCCH).
- MCCH repetition period (only S-CCPCH carrying MCCH).
- MCCH access info period (only S-CCPCH carrying MCCH).
- MSCH scheduling period/offset (only S-CCPCH carrying MSCH).

10.3.5.4a Secondary CCPCH frame type 2

- Channelisation code(s).
- Sub-frame.
- MSCH scheduling period/offset (only S-CCPCH carrying MSCH).

10.3.5.5 PRACH

- Access Slot (FDD only).
- Preamble scrambling code (FDD only).
- Available preamble signatures (FDD only).
- Spreading factor for data part.
- Power control info:
 - UL target SIR;
 - primary CCPCH DL TX Power;
 - UL interference;
 - power offset (Power ramping) (FDD only).
- Access Service Class Information (PRACH Partitioning):
 - Available signatures for each ASC (FDD only).
 - Available Channelisation codes for each ASC (TDD only).
 - Available Subchannels for each ASC.
- AICH transmission timing parameter (FDD only).
- Timeslots (TDD only).
- Available Channelisation Codes (TDD only)
- Spreading Factor (TDD only).
- Midamble Type (TDD only).

10.3.5.6 Uplink DPDCH+DPCCH

- UL scrambling code.
- DPCCH slot structure (N_{pilot} , N_{TPC} , N_{TFCI} , N_{FBI}).
- Transmission Time offset value.

10.3.5.7 Uplink DPCH

- Timing Advance (TDD only).
- DPCH channelisation code (TDD only).
- Burst Type (3.84/7.68 Mcps TDD only).
- DPCH midamble shift (TDD only).
- Timeslot (TDD only).
- Offset (TDD only).
- Repetition Period (TDD only).
- Repetition length (TDD only).
- TFCI presence (TDD only).

10.3.5.8 Downlink DPCH

- Transmission Time offset value.
- DL scrambling code:
 - DL Channelisation code.
- Tx diversity mode:
 - FB mode (FDD only).
- Slot structure ($N_{\text{pilot}}, N_{\text{TPC}}, N_{\text{TFCI}}, N_{\text{FBI}}, N_{\text{data1}}, N_{\text{data2}}$) (FDD only).
- Burst Type (3.84/7.68 Mcps TDD only).
- DPCH midamble shift (TDD only).
- Timeslot (TDD only).
- Offset (TDD only).
- Repetition period (TDD only).
- Repetition length (TDD only).
- TFCI presence (TDD only).

10.3.5.8a F-DPCH (FDD only)

- Transmission Time offset value.
- DL scrambling code:
 - DL Channelisation code.

10.3.5.9 Void

10.3.5.10 PICH

- Scrambling code.
- Channelisation code.
- Timeslot (TDD only).
- Burst Type (3.84/7.68 Mcps TDD only).
- Midamble shift (TDD only).
- Offset (TDD only).
- Repetition period (TDD only).
- Repetition length (TDD only).

10.3.5.11 AICH

- Scrambling code.
- Channelisation code.
- Tx diversity mode.

NOTE: The value for the parameters needs to be consistent with the corresponding PRACH.

10.3.5.12 Void

10.3.5.13 Void

10.3.5.14 Void

10.3.5.15 Void

10.3.5.16 PDSCH (TDD only)

- Scrambling code.
- Channelisation code.
- Tx diversity mode:
- DL channelisation code (TDD only).
- Burst Type (3.84/7.68 Mcps TDD only).
- PDSCH Midamble shift (TDD only).
- Timeslot (TDD only).
- Offset (TDD only).
- Repetition period (TDD only).
- Repetition length (TDD only).
- TFCI presence (TDD only).

10.3.5.17 PUSCH

- PUSCH channelisation code.
- Burst Type (3.84/7.68 Mcps TDD only).
- PUSCH midamble shift (TDD only).
- Timeslot (TDD only).
- Offset (TDD only).
- Repetition period (TDD only).
- Repetition length (TDD only).
- TFCI presence (TDD only).
- Timing Advance (TDD only).

10.3.5.18 DwPCH (1.28 Mcps TDD only)

- Tx diversity mode.
- SYNC_DL code ID.

10.3.5.19 UpPCH (1.28 Mcps TDD only)

- SYNC_UL code ID.

10.3.5.20 FPACH (1.28 Mcps TDD only)

- Scrambling code
- Channelisation code
- Timeslot
- Midamble shift
- Tx diversity mode.

10.3.5.21 PNBSCH (Physical Node B Synchronisation channel)

- Node B - Node B over the air communication.
- Only for TDD cells.
- Repetition period.
- Concatenated periodically Extended Complementary sequences.

10.3.5.22 HS-SCCH

- Scrambling code.
- Channelisation code.
- Timeslot (TDD only).
- Burst type (3.84/7.68 Mcps TDD only).

10.3.5.23 HS-SICH (TDD only)

- Channelisation code.
- Burst Type 1 (3.84/7.68 Mcps TDD only).
- Midamble shift.
- Timeslot.

10.3.5.24 E-AGCH

- Scrambling code.
- Channelisation code.
- Tx diversity mode.
- Timeslot (TDD only).
- Burst type (3.84 Mcps and 7.68 Mcps TDD only).

10.3.5.25 E-DPCCH (FDD only)

- No parameter.

10.3.5.26 E-DPDCH (FDD only)

- No parameter.

10.3.5.27 E-HICH

FDD:

- Scrambling code.
- Channelisation code.
- Hadamard sequence.

TDD:

- Scrambling code.
- Channelisation code.
- First Hadamard sequence.
- Second Hadamard sequence.
- Timeslot.

10.3.5.28 E-RGCH (FDD only)

- Scrambling code.
- Channelisation code.
- Hadamard sequence.

10.3.5.28a E-RUCCH (TDD only)

- Power control info:
 - UL target SIR;
 - primary CCPCH DL TX Power;
 - UL interference.
- Timeslot;
- Available Channelisation Code;
- Random access type (1.28 Mcps TDD only)

10.3.5.29 MICH

- Scrambling code.
- Channelisation code.
- Timeslot (TDD only).
- Burst Type (3.84/7.68 Mcps TDD only).
- Midamble shift (TDD only).

- Offset (TDD only).
- Repetition period (TDD only).
- Repetition length (TDD only).

10.3.6 Feedback information

In CELL_DCH state:

- Quality indication (HS-DSCH only).
- HARQ Status (HS-DSCH and E-DCH only).

In CELL_FACH state, if a common E-DCH is allocated to a UE (FDD only):

- Quality indication (HS-DSCH only).
- HARQ Status (HS-DSCH and E-DCH only).

In Idle mode, if a common E-DCH is allocated to a UE (FDD only):

- HARQ Status (E-DCH only).

10.3.7 HARQ process

- Process Id.

10.3.8 HS-DSCH information

- Modulation scheme.
- Channelisation code.
- Timeslot (TDD only).
- Redundancy version/Constellation.
- Process Id.
- HS-SCCH Cyclic Sequence Number (HCSN) for TDD.

10.3.9 HARQ status

- HARQ acknowledgement (acknowledgement or negative acknowledgement).

10.3.10 E-DCH information

- Number of allowed redundancy versions.
- Maximum number of transmissions
- New transmission indication
- Process Id.
- Power offset

10.3.11 MBMS information

- MBMS L1 combining schedule.
- MBMS service transmission schedule.

11 Transport block transmission

Data exchange between MAC and the physical layer, is defined in terms of Transport Block Sets (TBS). On a Transport Channel, one Transport Block Set can be transmitted for every Transmission Time Interval. A TBS consists of one or several Transport Blocks which shall be numbered $1, \dots, m, \dots, M$ and is delivered in the order of the index m . A Transport Block is identical with a MAC PDU. A Transport Block (MAC PDU) is a bit string ordered from first to last, where the first and last bits are numbered 1 and A , respectively, where A is the number of bits of the Transport Block. In case of Transport Block size=0 bit and $M \neq 0$, only parity bits as given by the CRC size are sent and $A=0$. This case is one realisation of an empty Transport Format. The second realisation of an empty Transport Format is represented by $M=0$ (no transport block). In this case, no parity bits are transmitted for this Transport Format.

The bits of the m th Transport Block in a TBS, are denoted as a_{im1}, \dots, a_{imA} for a Transport Channel identified by an index i (cf. [3] and [4]).

Annex A (normative): Description of Transport Formats

The following table describes the characterisation of a Transport Format.

Table A.1: Characterisation of Transport Format

		Attribute values	BCH	PCH	FACH	RACH
Dynamic part	Transport Block Size	0 to 5 000 1 bit granularity	246	1 to 5000 1 bit granularity	0 to 5 000 1 bit granularity	0 to 5 000 1 bit granularity
	Transport Block Set Size	0 to 200 000 1 bit granularity	246	1 to 200 000 1 bit granularity	0 to 200 000 1 bit granularity	0 to 200 000 1 bit granularity
	Transmission Time Interval (option for TDD only)	10, 20 ms, 40 and 80 ms				
Semi-static part	Transmission Time Interval (FDD, option for TDD NRT bearers)	10, 20 ms, 40 and 80 ms	20 ms 40ms (only for 1.28 Mcps TDD MBSFN only mode)	10ms for FDD, 20ms for TDD	10, 20 ms, 40 and 80 ms	10 ms and 20 ms for FDD, 10 ms for 3.84/7.68 Mcps TDD 5ms, 10ms and 20ms for 1.28 Mcps TDD
	Type of channel coding	No Coding (TDD only) Turbo coding Convolutional coding	Convolutional coding	Convolutional coding	No coding (TDD only) Turbo coding Convolutional coding	Convolutional coding
	Code rates	1/2, 1/3	1/2 for FDD and 3.84/7.68 Mcps TDD 1/3 for 1.28 Mcps TDD	1/2 for FDD and 3.84/7.68 Mcps TDD 1/2, 1/3 for 1.28 Mcps TDD	1/2, 1/3	1/2
	CRC size	0, 8, 12, 16, 24	16	0, 8, 12, 16, 24	0, 8, 12, 16, 24	0, 8, 12, 16, 24
	Resulting ratio after static rate matching	0,5 to 4				

		Attribute values	DCH	DSCH	USCH
Dynamic part	Transport Block Size	0 to 5 000 1 bit granularity	0 to 5 000 1 bit granularity	0 to 5 000 1 bit granularity	0 to 5 000 1 bit granularity
	Transport Block Set Size	0 to 200 000 1 bit granularity	0 to 200 000 1 bit granularity	0 to 200 000 1 bit granularity	0 to 200 000 1 bit granularity
	Transmission Time Interval (option for TDD only)	10, 20 ms, 40 and 80 ms	10, 20 ms, 40 and 80 ms	10, 20 ms, 40 and 80 ms	10, 20 ms, 40 and 80 ms
Semi-static part	Transmission Time Interval (FDD, option for TDD NRT bearers)	10, 20 ms, 40 and 80 ms	10, 20 ms, 40 and 80 ms	10, 20 ms, 40 and 80 ms	10, 20 ms, 40 and 80 ms
	Type of channel coding	No coding (TDD only) Turbo coding Convolutional coding	No coding (TDD only) Turbo coding Convolutional coding	No coding (TDD only) Turbo coding Convolutional coding	No coding (TDD only) Turbo coding Convolutional coding
	code rates (in case of convolutional coding)	1/2, 1/3	1/2, 1/3	1/2, 1/3	1/2, 1/3
	CRC size	0, 8, 12, 16, 24	0, 8, 12, 16, 24	0, 8, 12, 16, 24	0, 8, 12, 16, 24
	Resulting ratio after static rate matching	0,5 to 4			

		HS-DSCH
Dynamic part	Transport Block Size	1 to 200 000 8 bit granularity
	Transport Block Set Size	1 to 200 000 8 bit granularity
	Modulation scheme	QPSK, 16 QAM
	Redundancy version/Constellation	1 to 8
Static part	Transmission Time Interval	2ms for FDD 5 ms for 1.28 Mcps TDD 10 ms for 3.84/7.68 Mcps TDD
	Type of channel coding	Turbo coding
	Code rates	1/3
	CRC size	24

		E-DCH
Dynamic part	Transport Block Size	FDD: 1 to 200 000 1 bit granularity 3.84 Mcps TDD: 1 to 92014 1.28 Mcps TDD: 1 to 11160
	Transport Block Set Size	FDD: 1 to 200 000 1 bit granularity 3.84 Mcps TDD: 1 to 92014 7.68 Mcps TDD: 1 to 177130 1.28 Mcps TDD: 1 to 11160
	Redundancy version	0 to 3
Semi-static part	Transmission Time Interval	(FDD only) 2ms, (FDD, 3.84 Mcps and 7.68 Mcps TDD) 10ms (1.28 Mcps TDD) 5ms
Static part	Type of channel coding	Turbo coding
	Code rates	1/3
	CRC size	24

NOTE 1: The maximum size of the Transport Block has been chosen so as to avoid any need for segmentation in the physical layer into sub-blocks (segmentation should be avoided in the physical layer).

NOTE 2: Code rate is fixed to 1/3 in case of Turbo coding.

NOTE 3: All channels using the same resources as the BCH (i.e. the same timeslot and code, e.g. in a multiframe pattern) have to use different Transport Formats than the BCH to allow the identification of the BCH channel by physical layer parameters. Due to the differing parameters, decoding of other transport channels than BCH will result in an erroneous CRC.

Annex B (informative): Example of Transport format attributes for AMR speech codec

The support for the AMR speech codec is exemplified below. On the radio interface, one Transport Channel is established per class of bits i.e. DCH A for class A, DCH B for class B and DCH C for class C. Each DCH has a different transport format combination set which corresponds to the necessary protection for the corresponding class of bits as well as the size of these class of bits for the various AMR codec modes.

With this principle, the AMR codec mode which is used during a given TTI can be deduced from the format of the transport channels DCH A, DCH B and DCH C for that particular TTI.

Note that a similar principle can also be applied for other source codecs e.g. other speech codecs or video codecs.

An example of transport channel description for each class of bits is given in table B.1.

Table B.1

	Attribute	Value		
		Class A	Class B	Class C
Dynamic part	Transport Block Size	81	103	60
		65	99	40
		75	84	0
		61	87	0
		58	76	0
		55	63	0
		49	54	0
		42	53	0
		39	0	0
	Transport Block Set Size	Same as the transport block sizes		
Semi-static part	Transmission Time Interval	20 ms		
	Type of channel coding	Convolutional coding		
	code rates	1/2, 1/3 + class-specific rate matching	None (TDD only), 1/2, 1/3 + class-specific rate matching	None (TDD only), 1/2, 1/3 + class-specific rate matching
	CRC size	8	0	0
	Resulting ratio after static rate matching	0.5 to 4 (with no coding the rate matching ratio needs to be >1)		

Annex C (informative): Change history

Change history							
Date	TSG #	TSG Doc.	CR	Rev	Subject/Comment	Old	New
08/1999	RP-04	RP-99309	-		Approved after TSG-RAN #4 and TSG-RAN WG2 #6 (08/1999) by correspondence and placed under Change Control	-	3.0.0
10/1999	RP-05	RP-99461	001		Making all transport block equally sized within a transport block set	3.0.0	3.1.0
	RP-05	RP-99461	002	1	UE Simultaneous Physical Channel Combinations in TDD Mode	3.0.0	3.1.0
	RP-05	RP-99461	004		Timing advance (TDD only)	3.0.0	3.1.0
	RP-05	RP-99461	005		Measurements for TDD provided by physical layer	3.0.0	3.1.0
	RP-05	RP-99461	006		Change of the Downlink model of the UE in relation to PCH	3.0.0	3.1.0
	RP-05	RP-99461	007		Physical channel description for TDD	3.0.0	3.1.0
	RP-05	RP-99461	008		Attributes of the semi-static part and coding terminology	3.0.0	3.1.0
	RP-05	RP-99461	009		Editorial changes following LS received from WG1	3.0.0	3.1.0
	RP-05	RP-99461	010		Support of Uplink Synchronization Feature in UL channels (TDD only)	3.0.0	3.1.0
	RP-05	RP-99461	011		Simultaneous reception of AICH and S-CCPCH	3.0.0	3.1.0
	RP-05	RP-99461	012		Removal of Measurement Precision Requirements	3.0.0	3.1.0
	RP-05	RP-99461	013		Compressed mode	3.0.0	3.1.0
	RP-05	RP-99461	014		Change of the model of the UE with respect to shared channel multiplexing	3.0.0	3.1.0
12/1999	RP-06	RP-99624	015		Alignment of measurement names with RAN	3.1.0	3.2.0
	RP-06	RP-99623	018		Compressed Mode description	3.1.0	3.2.0
	RP-06	RP-99624	022		Alignment with TDD layer 1	3.1.0	3.2.0
	RP-06	RP-99624	023	1	Physical Channel Parameters	3.1.0	3.2.0
	RP-06	RP-99624	025		Addition of PICH and Corrections for Primary	3.1.0	3.2.0
	RP-06	RP-99624	026		Removal of compressed mode inband signalling	3.1.0	3.2.0
	RP-06	RP-99624	028	1	Measurement of Transmitted carrier power	3.1.0	3.2.0
	RP-06	RP-99623	030	1	Editorial issues	3.1.0	3.2.0
	RP-06	RP-99624	031		Measurement of Physical Channel BER	3.1.0	3.2.0
01/2000	-	-	-		E-mail approval by TSG-RAN WG2 of different implementation of CR 015 and CR 028 according to authors' intentions	3.2.0	3.3.0
03/2000	RP-07	RP-000035	032	2	Revision of CPCH model	3.3.0	3.4.0
	RP-07	RP-000035	033	1	Error Correction Coding for FACH	3.3.0	3.4.0
	RP-07	RP-000035	034	3	Revision of compressed mode description	3.3.0	3.4.0
	RP-07	RP-000035	036		TrBLK size	3.3.0	3.4.0
	RP-07	RP-000035	037		PDSCH multi-code	3.3.0	3.4.0
	RP-07	RP-000035	038	1	Primitives for CPCH Abnormal Situation Handling	3.3.0	3.4.0
	RP-07	RP-000035	039		Physical channel BER	3.3.0	3.4.0
	RP-07	RP-000035	041		Editorial modification on AMR trblk size	3.3.0	3.4.0
	RP-07	RP-000035	042	1	Corrections and clarifications on L1 and L2 functionality descriptions	3.3.0	3.4.0
	RP-07	RP-000035	043	1	Transport Block Transmission	3.3.0	3.4.0
	RP-07	RP-000035	044		Clarification to layer 1 model regarding transport blocks received by UE with CRC failure	3.3.0	3.4.0
	RP-07	RP-000035	045		Removal of SCH and SCCH	3.3.0	3.4.0
	RP-07	RP-000035	046		Replacement of Time of Arrival Measurement by RTT	3.3.0	3.4.0
	RP-07	RP-000035	047	1	Incorporation of Measurement filtering model	3.3.0	3.4.0
	RP-07	RP-000035	048		Separation of physical channel BER measurements	3.3.0	3.4.0
06/2000	RP-08	RP-000215	049	1	Maximum number of simultaneous compressed mode pattern sequences per measurement purpose	3.4.0	3.5.0
	RP-08	RP-000215	050	1	Removal of CPICH SIR measurement quantity	3.4.0	3.5.0
	RP-08	RP-000215	051		Measurements	3.4.0	3.5.0
	RP-08	RP-000215	052	1	End of CPCH transmission	3.4.0	3.5.0
	RP-08	RP-000215	053	1	Measurements of RACH and CPCH	3.4.0	3.5.0
	RP-08	RP-000215	056		Editorial modification on Transport Block Size	3.4.0	3.5.0
	RP-08	RP-000215	057	3	CPCH correction	3.4.0	3.5.0
	RP-08	RP-000215	058	1	SFN Transmission Rate and the Need to Maintain CFN in TDD Mode	3.4.0	3.5.0
	RP-08	RP-000215	059		Addition of out-of-sync-configuration control primitives	3.4.0	3.5.0
	RP-08	RP-000215	060		Addition of propagation delay measurement	3.4.0	3.5.0
	RP-08	RP-000215	061	2	Layer 1 LCS measurements	3.4.0	3.5.0
	RP-08	RP-000215	062	1	Refinement of the definition of a Transport Block	3.4.0	3.5.0
	RP-08	RP-000215	063	1	Corrections of CPCH Emergency stop and start of message Indicator	3.4.0	3.5.0
	RP-08	RP-000215	064		BLER	3.4.0	3.5.0
09/2000	RP-09	RP-000353	065		Filtering period in case of periodical reporting	3.5.0	3.6.0

Change history							
Date	TSG #	TSG Doc.	CR	Rev	Subject/Comment	Old	New
	RP-09	RP-000353	066		UE simultaneous Physical and Transport channel combinations for PDSCH and DSCH	3.5.0	3.6.0
	RP-09	RP-000353	067		Inclusion of SIR ERROR measurement	3.5.0	3.6.0
	RP-09	RP-000353	068	1	Simultaneous reception of PCCPCH and SCCPCH	3.5.0	3.6.0
	RP-09	RP-000353	070		Removal of puncturing limit from the transport format definition	3.5.0	3.6.0
	RP-09	RP-000353	071		Clarification of the Timeslot ISCP Measurements	3.5.0	3.6.0
12/2000	RP-10	RP-000563	072		RACH model	3.6.0	3.7.0
	RP-10	RP-000563	073		Clarification of UTRAN SIR measurement	3.6.0	3.7.0
	RP-10	RP-000563	074		Removal of compressed mode measurement purpose "other"	3.6.0	3.7.0
	RP-10	RP-000563	075		Removal of compressed mode measurement purpose "GSM"	3.6.0	3.7.0
	RP-10	RP-000563	076		Removal of physical channel BER measurement for TDD	3.6.0	3.7.0
	RP-10	RP-000563	077		CPCH model correction	3.6.0	3.7.0
	RP-10	RP-000563	078	1	Removal of FAUSCH and ODMA	3.6.0	3.7.0
	RP-10	RP-000563	080	2	Correction to transport channel mapping	3.6.0	3.7.0
	RP-10	RP-000563	081		Alignment of measurement reference description	3.6.0	3.7.0
	RP-10	RP-000563	082		Changing the name of "RSSI" to "Received total wide band power"	3.6.0	3.7.0

Change history							
Date	TSG #	TSG Doc.	CR	Rev	Subject/Comment	Old	New
03/2001	RP-11	RP-010020	084	2	Additional physical channel combination for FDD downlink to allow COUNT-C-SFN difference measurement	3.7.0	3.8.0
	RP-11	RP-010020	087		In & Out of Sync Indications per CCTrCH in TDD	3.7.0	3.8.0
	RP-11	RP-010020	088		Correction & Clarification to TDD RACH Model and Primitives	3.7.0	3.8.0
	RP-11	RP-010020	089	1	Alignment of measurements provided by the physical layer	3.7.0	3.8.0
	RP-11	RP-010020	092	1	Physical channel combinations in TDD	3.7.0	3.8.0
	RP-11	RP-010020	094		Measurement model clarifications	3.7.0	3.8.0
	RP-11	RP-010020	095		Removal of DPCCCH Gating from Release 99	3.7.0	3.8.0
	RP-11	RP-010020	096	1	Clarification of simultaneous operation of DRAC and CTCH	3.7.0	3.8.0
	RP-11	RP-010037	090	2	1.28 Mcps TDD	3.8.0	4.0.0
	RP-11	RP-010041	093	1	Measurements for Node B synchronisation	3.8.0	4.0.0
06/2001	RP-12	RP-010303	100		Physical Channel Combination	4.0.0	4.1.0
	RP-12	RP-010303	102		General corrections and clarifications	4.0.0	4.1.0
	RP-12	RP-010303	105		Definition of empty TF and TFC	4.0.0	4.1.0
	RP-12	RP-010320	106		Timing Advance (TADV) for 1.28 Mcps TDD	4.0.0	4.1.0
09/2001	RP-13	RP-010537	098		Transmission of selected ASC to physical layer	4.1.0	4.2.0
	RP-13	RP-010537	108		Corrected definition of the CCTrCH concerning BCH, RACH and CPCH	4.1.0	4.2.0
	RP-13	RP-010537	110		Transport Format Set Annex Correction	4.1.0	4.2.0
	RP-13	RP-010537	112		Corrections on un-supported features	4.1.0	4.2.0
12/2001	RP-14	RP-010754	116		Correction of control primitive parameter (CPHY-Out-of-Sync-Config)	4.2.0	4.3.0
	RP-14	RP-010769	117		UTRAN SFN-SFN observed time difference measurement	4.2.0	4.3.0
03/2002	RP-15	RP-020231	121	1	Removal of channel coding option "no coding" for FDD	4.3.0	4.4.0
	RP-15	RP-020079	119	1	UE GPS Code Phase Measurement	4.3.0	4.4.0
	RP-15	RP-020090	118		Introduction of AOA measurement for 1.28Mcps TDD	4.4.0	5.0.0
	RP-15	RP-020094	122	2	Introduction of HSDPA	4.4.0	5.0.0
06/2002	RP-16	RP-020322	127		Correction to inconsistency between 25.302 and RRM Specifications (25.123/25.133)	5.0.0	5.1.0
	RP-16	RP-020341	128		HSDPA corrections	5.0.0	5.1.0
09/2002	RP-17	RP-020665	131	1	Correction of transport to physical channel mapping for TDD	5.1.0	5.2.0
12/2002	RP-18	RP-020715	134		Two realisations of an Empty Transport Format	5.2.0	5.3.0
	RP-18	RP-020732	135		Corrections to the channel models for TDD	5.2.0	5.3.0
03/2003	RP-19	RP-030112	136		HCSN in TDD DL physical model	5.3.0	5.4.0
	RP-19	RP-030112	137		Correction on HSDPA physical channel combination	5.3.0	5.4.0
06/2003	RP-20	RP-030299	138		Measurements on HS-SICH for UTRA TDD	5.4.0	5.5.0
	RP-20	RP-030278	139		Power Measurement in non HSDPA codes for TDD	5.4.0	5.5.0
09/2003	RP-21	RP-030480	142		Correction to FDD downlink transport channel combinations for SCCPCH	5.5.0	5.6.0
	RP-21	RP-030492	143		Correcting model of the UE's physical layer regarding DCH with HS-DSCH	5.5.0	5.6.0
12/2003	RP-22	RP-030622	144		Correction to TDD HSDPA channel combinations	5.6.0	5.7.0
	RP-22	-	-		Upgrade to Release 6 - no technical change	5.7.0	6.0.0
03/2004	RP-23	RP-040088	145		Interference measurement in UpPTS for 1.28Mcps TDD	6.0.0	6.1.0
12/2004	RP-26	RP-040550	146	2	Introduction of Enhanced Uplink	6.1.0	6.2.0
03/2005	RP-27	RP-050089	148		Release 6 HS-DSCH operation without a DL DPCH for 3.84 Mcps TDD	6.2.0	6.3.0
	RP-27	RP-050074	149		Introduction of F-DPCH	6.2.0	6.3.0
	RP-27	RP-050076	150	1	Introduction of MBMS	6.2.0	6.3.0
	RP-27	RP-050050	151		Introduction of 'DL Transmission Branch Load' measurement	6.2.0	6.3.0
06/2005	RP-28	RP-050318	0152		Correction to the description of RACH transport channel	6.3.0	6.4.0
	RP-28	RP-050318	0153		Add physical layer signalling information in the figures of UE's physical layer model for TDD mode	6.3.0	6.4.0
	RP-28	RP-050322	0154		Release 6 HS-DSCH operation without a DL DPCH for 3.84 Mcps TDD	6.3.0	6.4.0
	RP-28	RP-050306	0156		Feature Clean Up: Removal of observed time difference to GSM cell	6.3.0	6.4.0
	RP-28	RP-050308	0158		Feature Clean-up: Removal of DSCH (FDD)	6.3.0	6.4.0
	RP-28	RP-050309	0160		Feature Clean Up: Removal of CPCH	6.3.0	6.4.0
	RP-28	RP-050311	0162		Feature Clean Up: Removal of DRAC	6.3.0	6.4.0
	RP-28	RP-050327	0163		Correction of E-DCH Relative Grants	6.3.0	6.4.0
	RP-28	RP-050456	0165		Feature Clean Up: Removal of CPCH	6.4.0	6.5.0
03/2006	RP-31	RP-060090	0166		Editorial correction on the Model of the UE's physical layer - downlink TDD mode	6.5.0	6.6.0
	RP-31	RP-060098	0167		7.68 Mcps TDD Option (Release 7)	6.6.0	7.0.0
06/2006	RP-32	RP-060351	0169		Definition of Non-serving E-DCH RLS or Non-serving RLS	7.0.0	7.1.0
	RP-32	RP-060351	0171		Removal of FFS regarding E-DCH	7.0.0	7.1.0
09/2006	RP-33	RP-060495	0173	2	Introduction of a Node B measurement for E-DCH RRM	7.1.0	7.2.0
	RP-33	RP-060574	0175		RGCH requirement in physical channel combinations	7.1.0	7.2.0
	RP-33	RP-060586	0176		Introduction of 3.84 and 7.68 Mcps TDD E-DCH	7.1.0	7.2.0
03/2007	RP-35	RP-070157	0177		Introduction of 1.28 Mcps TDD E-DCH	7.2.0	7.3.0

Change history							
Date	TSG #	TSG Doc.	CR	Rev	Subject/Comment	Old	New
	RP-35	RP-070165	0178		Alignment of 25.302 with 25.321 and 25.331 to enable HS-DSCH operation without an associated DL DPCH for all TDD modes	7.2.0	7.3.0
06/2007	RP-36	RP-070403	0179	1	Introduction of Enhanced CELL_FACH state in FDD	7.3.0	7.4.0
09/2007	RP-37	RP-070628	0180	1	Adding GANSS related services within the list of services provided by the physical layer	7.4.0	7.5.0
12/2007	RP-38	RP-070902	0181		More improvement on Dedicated Carrier for 1.28Mcps TDD MBMS	7.5.0	7.6.0
	RP-38	-	-		Upgrade to Release 8 - no technical change	7.6.0	8.0.0
09/2008	RP-41	RP-080696	0183		Introduction of Enhanced Uplink in CELL_FACH in 25.302	8.0.0	8.1.0
12/2008	RP-42	RP-081022	0184	1	Replacement of E-AICH in 25.302	8.1.0	8.2.0
	RP-42	RP-081025	0185	-	Introduction of enhanced CELL_FACH, CELL_PCH and URA_PCH for 1.28Mcps TDD	8.1.0	8.2.0
06/2009	RP-44	RP-090519	0186	-	Support for 3.84 Mcps MBSFN IMB operation	8.2.0	8.3.0
09/2009	RP-45	RP-090904	0188	-	Introduction of Rel-7 HSDPA MIMO for FDD	8.3.0	8.4.0
12/2009	RP-46	RP-091308	0190	-	Updates to Rel-7 HSDPA MIMO for FDD	8.4.0	8.5.0
	RP-46	RP-091325	0191	1	Introduction of DC-HSDPA for FDD	8.4.0	8.5.0
12/2009	RP-46	RP-091336	0192	-	Introduction of DC-HSUPA, DC-HSDPA+MIMO, and Dual Band HSDPA for FDD	8.4.0	9.0.0
03/2010	RP-47	RP-100290	0194	-	Corrections to FDD DL physical channel combinations	9.0.0	9.1.0
	RP-47	RP-100303	0195	-	Clarification of FDD DL channel combination applicability for DC-HSUPA	9.0.0	9.1.0
09/2010	RP-49	RP-100883	0201	-	Corrections to physical channel combinations for Enhanced CELL_FACH state for FDD	9.1.0	9.2.0
09/2010	RP-49	-	-		v10.0.0 created based on v9.2.0	9.2.0	10.0.0
	RP-49	RP-100863	0202	-	Introduction of 4C-HSDPA for FDD	9.1.0	10.0.0
12/2010	RP-50	RP-101365	0203	2	Introduction of MC-HSUPA for 1.28Mcps TDD	10.0.0	10.1.0
	RP-50	RP-101366	0204	2	Introduction of 4C-HSDPA definitions	10.0.0	10.1.0
09/2011	RP-53	RP-111296	0205	1	Correction to the model of physical layer for 1.28Mcps TDD multi-carrier HSDPA	10.1.0	10.2.0
12/2011	RP-54	RP-111736	0207	3	Introduction of uplink CLTD and 8C-HSDPA into 25.302	10.2.0	11.0.0
09/2012	RP-57	RP-121369	0211	1	Introduction of Multiflow in TS 25.302	11.0.0	11.1.0
	RP-57	RP-121366	0212	-	Correction on F-TPICH transmission for UL CLTD	11.0.0	11.1.0
12/2012	RP-58	RP-121942	0215	-	Introduction of 4Tx-HSDPA in 25.302	11.1.0	11.2.0
	RP-58	RP-121945	0216	1	Introduction of UL MIMO with 64QAM in TS 25.302	11.1.0	11.2.0
	RP-58	RP-121943	0217	-	Introduction of Multiflow and CLTD	11.1.0	11.2.0
03/2013	RP-59	RP-130239	0218	-	Introduction of FE-FACH subfeature concurrent deployment of 2ms and 10ms TTI in a cell	11.2.0	11.3.0
06/2013	RP-60	RP-130806	0220	1	Combination of Multiflow and UL MIMO	11.3.0	11.4.0