

3GPP TS 25.224 V11.1.0 (2012-12)

Technical Specification

3rd Generation Partnership Project; Technical Specification Group Radio Access Network; Physical layer procedures (TDD) (Release 11)



The present document has been developed within the 3rd Generation Partnership Project (3GPPTM) and may be further elaborated for the purposes of 3GPP.

The present document has not been subject to any approval process by the 3GPP Organisational Partners and shall not be implemented. This Specification is provided for future development work within 3GPP only. The Organisational Partners accept no liability for any use of this Specification. Specifications and reports for implementation of the 3GPPTM system should be obtained via the 3GPP Organisational Partners' Publications Offices.

Keywords

UMTS, radio, layer 1

3GPP

Postal address

3GPP support office address

650 Route des Lucioles - Sophia Antipolis
Valbonne - FRANCE
Tel.: +33 4 92 94 42 00 Fax: +33 4 93 65 47 16

Internet

<http://www.3gpp.org>

Copyright Notification

No part may be reproduced except as authorized by written permission.
The copyright and the foregoing restriction extend to reproduction in all media.

© 2012, 3GPP Organizational Partners (ARIB, ATIS, CCSA, ETSI, TTA, TTC).
All rights reserved.

UMTS™ is a Trade Mark of ETSI registered for the benefit of its members
3GPP™ is a Trade Mark of ETSI registered for the benefit of its Members and of the 3GPP Organizational Partners
LTE™ is a Trade Mark of ETSI currently being registered for the benefit of its Members and of the 3GPP Organizational Partners
GSM® and the GSM logo are registered and owned by the GSM Association

Contents

Foreword	8
1 Scope	9
2 References.....	9
3 Abbreviations	10
4 Physical layer procedures for the 3.84 Mcps option	11
4.1 General	11
4.2 Transmitter Power Control	11
4.2.1 General Parameters	11
4.2.2 Uplink Control	11
4.2.2.1 General Limits	11
4.2.2.2 PRACH	12
4.2.2.3 DPCH, PUSCH and HS-SICH	12
4.2.2.3.1 Gain Factors	12
4.2.2.3.2 Out of synchronisation handling	13
4.2.2.4 E-PUCH.....	13
4.2.2.4.1 Gain Factors for E-PUCH	14
4.2.2.5 E-RUCCH	15
4.2.3 Downlink Control.....	15
4.2.3.1 P-CCPCH	15
4.2.3.2 S-CCPCH, PICH	15
4.2.3.2A MICH	15
4.2.3.3 SCH	16
4.2.3.3A PNBSCH	16
4.2.3.4 DPCH, PDSCH	16
4.2.3.4.1 Out of synchronisation handling	17
4.2.3.5 HS-PDSCH	17
4.2.3.6 HS-SCCH	17
4.2.3.7 E-AGCH	17
4.2.3.8 E-HICH	17
4.3 Timing Advance	17
4.4 Synchronisation procedures.....	18
4.4.1 Cell Search	18
4.4.2 Dedicated channel synchronisation.....	18
4.4.2.1 Synchronisation primitives.....	18
4.4.2.1.1 General.....	18
4.4.2.1.2 Downlink synchronisation primitives	18
4.4.2.1.2A Downlink synchronisation primitives for HS-channels	19
4.4.2.1.3 Uplink synchronisation primitives	19
4.4.2.2 Radio link monitoring	20
4.4.2.2.1 Downlink radio link failure	20
4.4.2.2.2 Uplink radio link failure/restore	20
4.5 Discontinuous transmission (DTX) procedure.....	20
4.5.1 Description of Special Bursts.....	20
4.5.2 Use of Special Bursts during DTX	21
4.5.3 Use of Special Bursts for Initial Establishment / Reconfiguration	21
4.5.4 Use of Special Bursts for DTX on Beacon Channels	21
4.6 Downlink Transmit Diversity.....	21
4.6.1 Transmit Diversity for PDSCH, DPCH, HS-SCCH, HS-PDSCH and E-AGCH	21
4.6.2 Transmit Diversity for SCH and S-CCPCH	22
4.6.2.1 SCH Transmission Scheme	22
4.6.2.2 S-CCPCH Transmission Scheme	23
4.6.3 Transmit Diversity for Beacon Channels.....	23
4.6.3.1 SCTD Transmission Scheme	23
4.7 Random access procedure.....	24
4.7.1 Physical random access procedure.....	24
4.7A E-RUCCH transmission procedure	25

4.8	DSCH procedure.....	25
4.8.1	DSCH procedure with TFCI indication.....	25
4.8.2	DSCH procedure with midamble indication	26
4.9	Node B Synchronisation Procedure over the Air.....	26
4.9.1	Frequency Acquisition Phase.....	26
4.9.2	Initial Synchronisation	26
4.9.3	Steady-State Phase.....	26
4.9.4	Late entrant cells	26
4.10	Idle periods for IPDL location method.....	27
4.10.1	General.....	27
4.10.2	Parameters of IPDL.....	27
4.10.3	Calculation of idle period position	27
4.11	HS-DSCH Procedure	28
4.11.1	Link Adaptation Procedure.....	28
4.11.2	HS-DSCH Channel Quality Indication Procedure	29
4.12	Macro-diversity procedure.....	30
4.13	E-DCH related procedures.....	30
4.13.1	ACK/NA CK detection	30
4.13.2	Serving and neighbour cell pathloss metric derivation.....	30
4.13.3	Channelisation code hopping procedure for E-PUCH.....	31
4.14	Physical Layer Procedures for 3.84 Mcps MBSFN IMB	33
4.14.1	Radio frame timing on the MBSFN layer	33
4.14.2	Downlink Power Control	33
4.14.2.1	S-CCPCH.....	33
4.14.2.2	MICH.....	33
4.14.2.3	P-CPICH.....	34
4.14.2.4	T-CPICH	34
5	Physical layer procedures for the 1.28 Mcps option	34
5.1	Transmitter Power Control	34
5.1.1	Uplink Control.....	34
5.1.1.1	General limits	34
5.1.1.2	UpPCH.....	34
5.1.1.3	PRA CH.....	35
5.1.1.4	DPCH and PUSCH.....	35
5.1.1.4.1	Gain Factors.....	35
5.1.1.4.2	Out of synchronization handling	35
5.1.1.5	HS-SICH	36
5.1.1.6	E-PUCH.....	37
5.1.1.6.1	Gain Factors for E-PUCH	38
5.1.1.7	E-RUCCH.....	39
5.1.1.8	Standalone midamble channel	39
5.1.2	Downlink Control.....	39
5.1.2.1	P-CCPCH.....	39
5.1.2.2	The power of the FPACH.....	39
5.1.2.3	S-CCPCH, PICH.....	39
5.1.2.3A	MICH.....	40
5.1.2.4	DPCH, PDSCH	40
5.1.2.4.1	Out of synchronisation handling	40
5.1.2.5	HS-PDSCH.....	40
5.1.2.6	HS-SCCH.....	40
5.1.2.7	PLCCH	41
5.1.2.8	E-AGCH.....	41
5.1.2.9	E-HICH.....	41
5.2	UL Synchronisation	41
5.2.1	General Description	41
5.2.1.1	Preparation of uplink synchronization (downlink synchronization)	41
5.2.1.2	Establishment of uplink synchronization.....	41
5.2.1.3	Maintenance of uplink synchronisation.....	42
5.2.2	UpPCH	42
5.2.3	PRA CH	42
5.2.4	DPCH and PUSCH	42

5.2.4.1	Out of synchronization handling	43
5.2.5	HS-SICH.....	43
5.2.6	E-PUCCH	43
5.2.7	E-RUCCH	44
5.2.8	Standalone midamble channel	44
5.3	Synchronisation procedures.....	44
5.3.1	Cell search	44
5.3.2	DCH synchronization	44
5.3.2A	Shared physical channel synchronization	44
5.3.2A.1	Synchronisation primitives.....	44
5.3.2A.1.1	General.....	44
5.3.2A.1.2	Downlink synchronisation primitives	44
5.3.2A.1.3	Uplink synchronisation primitives.....	45
5.3.2A.2	Radio link monitoring	45
5.3.2A.2.1	Downlink radio link failure	45
5.3.2A.2.2	Uplink radio link failure/restore.....	45
5.3.3	Synchronization procedure in CELL_FACH state.....	46
5.3.3.1	Uplink synchronization status detection.....	46
5.3.3.2	Establishment of uplink synchronization.....	46
5.4	Discontinuous transmission (DTX) procedure.....	46
5.4.1	Description of Special Bursts.....	46
5.4.2	Use of Special Bursts during DTX.....	47
5.4.3	Use of Special Bursts for Initial Establishment / Reconfiguration	47
5.5	Downlink Transmit Diversity.....	47
5.5.1	Transmit Diversity for PDSCH, DPCH, HS-SCCH, HS-PDSCH and E-AGCH	47
5.5.1.1	TSTD for PDSCH and DPCH	47
5.5.1.2	Closed Loop Tx Diversity for PDSCH, DPCH, HS-SCCH, HS-PDSCH and E-AGCH	48
5.5.2	Transmit Diversity for DwPCH.....	49
5.5.3	Transmit Diversity for P-CCPCH	49
5.5.3.1	TSTD Transmission Scheme for P-CCPCH	49
5.5.4	SCTD Transmission Scheme for Beacon Channels	49
5.6	Random Access Procedure	50
5.6.1	Definitions	50
5.6.1A	UpPCH sub-channel	51
5.6.2	Preparation of random access.....	51
5.6.3	Random access procedure.....	52
5.6.3.1	The use and generation of the information fields transmitted in the FPACH	53
5.6.3.1.1	Signature Reference Number.....	53
5.6.3.1.2	Relative Sub-Frame Number	54
5.6.3.1.3	Received starting position of the UpPCH (UpPCH _{POS}).....	54
5.6.3.1.4	Transmit Power Level Command for the RACH message.....	54
5.6.3A	E-RUCCH procedure.....	54
5.6.4	Random access collision	55
5.7	Node B Synchronisation Procedure over the Air.....	55
5.7.1	Initial Synchronisation	55
5.7.2	Steady-State Phase.....	55
5.7.3	Late entrant cells	56
5.8	Idle periods for IPDL location method	56
5.8.1	General	56
5.8.2	Parameters of IPDL	56
5.8.3	Calculation of idle period position	56
5.9	HS-DSCH Procedure in CELL_DCH state.....	57
5.9.1	Link Adaptation Procedure.....	57
5.9.2	HS-DSCH Channel Quality Indication Procedure	58
5.9.3	HS-SCCH monitoring procedure	59
5.9A	HS-DSCH Procedure in CELL_FACH state	60
5.9A.1	Link Adaptation Procedure.....	60
5.9A.2	HS-DSCH Channel Quality Indication Procedure	60
5.9A.3	HS-SCCH monitoring procedure	60
5.9B	HS-DSCH Procedure in CELL_PCH or URA_PCH state	60
5.9B.1	Link Adaptation Procedure.....	60
5.9B.2	HS-DSCH Channel Quality Indication Procedure	61

5.9B.3	HS-SCCH monitoring procedure	61
5.10	Macro-diversity procedure.....	61
5.11	E-DCH Procedure.....	62
5.11.1	ACK/NA CK detection	62
5.11.2	Serving and neighbour cell pathloss metric derivation	62
5.11.3	E-AGCH monitoring in CELL_DCH state.....	63
5.11.3A	E-AGCH monitoring in CELL_FACH state	63
5.12	MIMO operation of HS-DSCH	64
5.12.1	General procedure	64
5.12.2	Identification of MIMO dual stream.....	64
5.12.3	UE antennas Time Switched Transmission	65
5.12A	MU-MIMO operation of HS-DSCH and E-DCH	65
5.13	Control Channel Discontinuous reception procedures.....	66
5.13.1	Discontinuous downlink reception.....	67
5.13.2	HS-SCCH orders	67
6	Physical layer procedures for the 7.68 Mcps option	68
6.1	Transmitter Power Control	68
6.2	Timing Advance	68
6.3	Synchronisation procedures.....	68
6.4	Discontinuous transmission (DTX) procedure.....	68
6.5	Downlink Transmit Diversity.....	69
6.5.1	Transmit Diversity for PDSCH, DPCH, HS-SCCH, HS-PDSCH and E-AGCH	69
6.5.2	Transmit Diversity for SCH and S-CCPCH	69
6.5.3	Transmit Diversity for Beacon Channels	69
6.5.3.1	SCTD Transmission Scheme	69
6.6	Random access procedure.....	69
6.6.1	Physical random access procedure.....	70
6.6A	E-RUCCH transmission procedure	70
6.7	DSCH procedure.....	70
6.8	Idle periods for IPDL location method	70
6.9	HS-DSCH Procedure	70
6.9.1	Link Adaptation Procedure.....	70
6.9.2	HS-DSCH Channel Quality Indication Procedure	71
6.10	Macro-diversity procedure.....	71
6.11	E-DCH related procedures	71
6.11.1	ACK/NA CK detection	71
6.11.2	Serving and neighbour cell pathloss metric derivation	71
6.11.3	Channelisation code hopping procedure for E-PUCH.....	71

Annex A (informative):	Power Control	74
A.1	Example Implementation of Downlink Power Control in the UE.....	74
A.2	Example Implementation of Closed Loop Uplink Power Control in Node B for 1.28Mcps TDD.....	74
A.3	Example Implementation of Downlink Power Control in UE for 1.28Mcps TDD when TSTD is used	74
A.4	Example Implementation of open Loop Power Control for access procedure for 1.28Mcps TDD.....	75
A.5	Example Implementation of Closed Loop Uplink HS-SICH Power Control in Node B for 1.28Mcps TDD.....	75
Annex B (informative):	Determination of Weight Information	76
B.1	STD Weights	76
B.2	TxAA Weights.....	76
Annex C (informative):	Cell search procedure for 3.84Mcps TDD	77
Annex CA (informative):	Cell search procedure for 1.28Mcps TDD.....	78
Annex CB (informative):	Examples random access procedure for 1.28Mcps TDD	80
Annex D (informative):	Change history.....	82

Foreword

This Technical Specification (TS) has been produced by the 3rd Generation Partnership Project (3GPP).

The contents of the present document are subject to continuing work within the TSG and may change following formal TSG approval. Should the TSG modify the contents of the present document, it will be re-released by the TSG with an identifying change of release date and an increase in version number as follows:

Version x.y.z

where:

- x the first digit:
 - 1 presented to TSG for information;
 - 2 presented to TSG for approval;
 - 3 or greater indicates TSG approved document under change control.
- y the second digit is incremented for all changes of substance, i.e. technical enhancements, corrections, updates, etc.
- z the third digit is incremented when editorial only changes have been incorporated in the document.

1 Scope

The present document describes the Physical Layer Procedures in the TDD mode of UTRA.

2 References

The following documents contain provisions which, through reference in this text, constitute provisions of the present document.

- References are either specific (identified by date of publication, edition number, version number, etc.) or non-specific.
- For a specific reference, subsequent revisions do not apply.
- For a non-specific reference, the latest version applies. In the case of a reference to a 3GPP document (including a GSM document), a non-specific reference implicitly refers to the latest version of that document *in the same Release as the present document*.

- [1] 3GPP TS 25.201: "Physical layer - general description".
- [2] 3GPP TS 25.102: "UE physical layer capabilities".
- [3] 3GPP TS 25.211: "Physical channels and mapping of transport channels onto physical channels (FDD)".
- [4] 3GPP TS 25.212: "Multiplexing and channel coding (FDD)".
- [5] 3GPP TS 25.213: "Spreading and modulation (FDD)".
- [6] 3GPP TS 25.214: "Physical layer procedures (FDD)".
- [7] 3GPP TS 25.215: "Physical Layer - Measurements (FDD)".
- [8] 3GPP TS 25.221: "Physical channels and mapping of transport channels onto physical channels (TDD)".
- [9] 3GPP TS 25.222: "Multiplexing and channel coding (TDD)".
- [10] 3GPP TS 25.223: "Spreading and modulation (TDD)".
- [11] 3GPP TS 25.225: "Physical Layer - Measurements (TDD)".
- [12] 3GPP TS 25.301: "Radio Interface Protocol Architecture".
- [13] 3GPP TS 25.302: "Services Provided by the Physical Layer".
- [14] 3GPP TS 25.401: "UTRAN Overall Description".
- [15] 3GPP TS 25.331: "RRC Protocol Specification"
- [16] 3GPP TS 25.433: "UTRAN Iub Interface NBAP Signalling"
- [17] 3GPP TS 25.105: "UTRA (BS) TDD; Radio transmission and Reception"
- [18] 3GPP TS 25.321: "MAC protocol specification"
- [19] 3GPP TS 25.303: "Interlayer Procedures in Connected Mode"
- [20] 3GPP TS 25.402: "Synchronisation in UTRAN Stage 2"

3 Abbreviations

For the purposes of the present document, the following abbreviations apply:

ACK	Acknowledgement
ASC	Access Service Class
BCCH	Broadcast Control Channel
BCH	Broadcast Channel
CCTrCH	Coded Composite Transport Channel
CDMA	Code Division Multiple Access
CQI	Channel Quality Information
CRC	Cyclic Redundancy Check
DCA	Dynamic Channel Allocation
DL	Downlink
DPCH	Dedicated Physical Channel
DTX	Discontinuous Transmission
E-AGCH	E-DCH Absolute Grant Channel
ECSN	E-AGCH Cyclic Sequence Number
E-DCH	Enhanced Dedicated Channel
E-HICH	E-DCH Hybrid ARQ Indicator Channel
ENI	E-UCCH Number Indicator
E-PUCH	E-DCH Physical Uplink Channel
E-RUCCH	E-DCH Random Access Uplink Control Channel
E-UCCH	E-DCH Uplink Control Channel
FACH	Forward Access Channel
FDD	Frequency Division Duplex
HS-DSCH	High Speed Downlink Shared Channel
HS-PDSCH	High Speed Physical Downlink Shared Channel
HS-SCCH	Shared Control Channel for HS-DSCH
HS-SICH	Shared Information Channel for HS-DSCH
IMB	Integrated Mobile Broadcast
ISCP	Interference Signal Code Power
MAC	Medium Access Control
MBMS	Multimedia Broadcast/Multicast Service
MBSFN	MBMS over a Single Frequency Network
MICH	MBMS Indicator Channel
MIMO	single user Multiple Input Multiple Output
MS burst	MBSFN Special burst
MT burst	MBSFN Traffic burst
MU-MIMO	Multi-user Multiple Input Multiple Output
NACK	Negative Acknowledgement
NRT	Non-Real Time
P-CCPCH	Primary Common Control Physical Channel
PC	Power Control
PDSCH	Physical Downlink Shared Channel
PICH	Paging Indicator Channel
PLCCH	Physical Layer Common Control Channel
PRACH	Physical Random Access Channel
PUSCH	Physical Uplink Shared Channel
RACH	Random Access Channel
RL	Radio Link
RRC	Radio Resource Control
RSCP	Received Signal Code Power
RT	Real Time
RU	Resource Unit
SBGP	Special Burst Generation Gap
SBP	Special Burst Period
SBSP	Special Burst Scheduling Period
S-CCPCH	Secondary Common Control Physical Channel
SCH	Synchronisation Channel
SCTD	Space Code Transmit Diversity

SFN	System Frame Number
SIR	Signal-to-Interference Ratio
SNPL	Serving and Neighbour cell Pathloss
SSCH	Secondary Synchronisation Channel
STD	Selective Transmit Diversity
TA	Timing Advance
TDD	Time Division Duplex
TF	Transport Format
TFC	Transport Format Combination
TFCI	Transport Format Combination Indicator
TFCS	Transport Format Combination Set
TFRI	Transport Format Resource Indicator
TPC	Transmit Power Control
TSTD	Time Switched Transmit Diversity
TTI	Transmission Time Interval
TxAA	Transmit Adaptive Antennas
UE	User Equipment
UL	Uplink
UMTS	Universal Mobile Telecommunications System
UTRAN	UMTS Radio Access Network
VBR	Variable Bit Rate

4 Physical layer procedures for the 3.84 Mcps option

4.1 General

Sub-clauses 4.2 to 4.13 do not apply to 3.84 Mcps MBSFN IMB operation. Physical layer procedures for 3.84 Mcps MBSFN IMB operation are described in sub-clause 4.14.

4.2 Transmitter Power Control

4.2.1 General Parameters

Power control is applied for the TDD mode to limit the interference level within the system thus reducing the intercell interference level and to reduce the power consumption in the UE.

All codes within one timeslot allocated to the same CCTrCH use the same transmission power, in case they have the same spreading factor.

Table 1: Transmit Power Control characteristics

	Uplink	Downlink
Power control rate	Variable 1-7 slots delay (2 slot SCH) 1-14 slots delay (1 slot SCH)	Variable, with rate depending on the slot allocation.
TPC Step size	--	1 dB or 2 dB or 3 dB
Remarks	All figures are without processing and measurement times	

4.2.2 Uplink Control

4.2.2.1 General Limits

During the operation of the uplink power control procedure the UE transmit power shall not exceed a maximum allowed value which is the lower out of the maximum output power of the terminal power class and a value which may be set by higher layer signalling.

Uplink power control shall be performed while the total UE transmit power is below the maximum allowed output power. In some cases the total UE transmit power in a timeslot after uplink power control calculation might exceed the maximum allowed output power. In these cases the calculated transmit power of all uplink physical channels in this timeslot shall be scaled by the same amount in dB before transmission. The total UE transmission power used shall be the maximum allowed output power.

The UTRAN may not expect the UE to be capable of reducing its total transmit power below the minimum level specified in [2].

4.2.2.2 PRACH

The transmit power for the PRACH is set by higher layers based on open loop power control as described in [15].

4.2.2.3 DPCH, PUSCH and HS-SICH

The transmit power for DPCH, PUSCH and HS-SICH is set by higher layers based on open loop power control as described in [15].

In the case that an ACK is being transmitted on the HS-SICH, the UE shall apply a power offset to the transmit power of the entire HS-SICH. This power offset shall be signalled by higher layers.

4.2.2.3.1 Gain Factors

Two or more transport channels may be multiplexed onto a CCTrCH as described in [9]. These transport channels undergo rate matching which involves repetition or puncturing. This rate matching affects the transmit power required to obtain a particular E_b/N_0 . Thus, the transmission power of the CCTrCH shall be weighted by a gain factor β .

There are two ways of controlling the gain factors for different TFC's within a CCTrCH transmitted in a radio frame:

- β is signalled for the TFC, or
- β is computed for the TFC, based upon the signalled settings for a reference TFC.

Combinations of the two above methods may be used to associate β values to all TFC's in the TFCS for a CCTrCH. The two methods are described in sections 4.2.2.3.1.1 and 4.2.2.3.1.2 respectively. Several reference TFC's for several different CCTrCH's may be signalled from higher layers.

The weight and gain factors may vary on a radio frame basis depending upon the current SF and TFC used. The setting of weight and gain factors is independent of any other form of power control. That means that the transmit power P_{UL} is calculated according to the formula given in [15] and then the weight and gain factors are applied on top of that, cf. [10].

4.2.2.3.1.1 Signalled Gain Factors

When the gain factor β_j is signalled by higher layers for a certain TFC, the signalled values are used directly for weighting DPCH or PUSCH within a CCTrCH. Exact values are given in [10].

4.2.2.3.1.2 Computed Gain Factors

The gain factor β_j may also be computed for certain TFCs, based on the signalled settings for a reference TFC:

Let β_{ref} denote the signalled gain factor for the reference TFC. Further, let β_j denote the gain factor used for the j -th TFC.

Define the variable:
$$K_{ref} = \sum_i RM_i \cdot N_i$$

where RM_i is the semi-static rate matching attribute for transport channel i , N_i is the number of bits output from the radio frame segmentation block for transport channel i and the sum is taken over all the transport channels i in the reference TFC.

Similarly, define the variable $K_j = \sum_i RM_i \cdot N_i$

where the sum is taken over all the transport channels i in the j -th TFC.

Moreover, define the variable $L_{ref} = \sum_i \frac{1}{SF_i}$

where SF_i is the spreading factor of DPCH or PUSCH i and the sum is taken over all DPCH or PUSCH i used in the reference TFC.

Similarly, define the variable $L_j = \sum_i \frac{1}{SF_i}$

where the sum is taken over all DPCH or PUSCH i used in the j -th TFC.

The gain factors β_j for the j -th TFC are then computed as follows:

$$\beta_j = \beta_{ref} \cdot \sqrt{\frac{L_{ref}}{L_j}} \cdot \sqrt{\frac{K_j}{K_{ref}}}$$

No quantisation of β_j is performed and as such, values other than the quantised β_j given in [10] may be used.

4.2.2.3.2 Out of synchronisation handling

As stated in 4.2.3.4, the association between TPC commands sent on uplink DPCH and PUSCH, with the power controlled downlink DPCH and PDSCH is signaled by higher layers. In the case of multiple DL CCTrCHs it is possible that an UL CCTrCH will provide TPC commands to more than one DL CCTrCH.

In the second phase of synchronisation evaluation, as defined in 4.4.2.1.2, the UE shall shut off the transmission of an UL CCTrCH if the following criteria are fulfilled for any one of the DL CCTrCHs commanded by its TPC:

- The UE estimates the received dedicated channel burst quality over the last 160 ms period to be worse than a threshold Q_{out} , and in addition, no special burst, as defined in 4.5, is detected with quality above a threshold, Q_{sbout} . Q_{out} and Q_{sbout} are defined implicitly by the relevant tests in [2]. If the UE detects the beacon channel reception level [10 dB] above the handover triggering level, then the UE shall use a 320 ms estimation period for the burst quality evaluation and for the Special Burst detection window.

UE shall subsequently resume the uplink transmission of the CCTrCH if the following criteria are fulfilled:

- The UE estimates the received dedicated CCTrCH burst reception quality over the last 160 ms period to be better than a threshold Q_{in} or the UE detects a burst with quality above threshold Q_{sbin} and TFCI decoded to be that of the Special Burst. Q_{in} and Q_{sbin} are defined implicitly by the relevant tests in [2]. If the UE detects the beacon channel reception level [10 dB] above the handover triggering level, then the UE shall use a 320 ms estimation period for the burst quality evaluation and for the Special Burst detection window.

4.2.2.4 E-PUCH

The power of E-PUCH is set based upon the sum of:

1. An open loop component based upon beacon channel pathloss and on the E-PUCH constant value signalled by higher layers (K_{E-PUCH}).
2. A closed-loop TPC component. One TPC bit is signalled to the UE within each E-AGCH. The TPC command is derived by Node-B.
3. An adjustment factor (β_e) accounting for the E-TFC selected by the UE and the HARQ offset.

The transmit power of the E-PUCH is calculated in the UE as follows:

$$P_{E-PUCH} = P_{e-base} + L + \beta_e + K_{E-PUCH}$$

... where:

- P_{e-base} is a closed-loop quantity maintained by the UE and which is incremented or decremented by a value Δ_{e-base} upon each receipt of a TPC command on E-AGCH. On receipt of a TPC “up” command, P_{e-base} is incremented by Δ_{e-base} . On receipt of a TPC “down” command, P_{e-base} is decremented by Δ_{e-base} . The TPC step size Δ_{e-base} is configured by higher layers [15].
- L is a pathloss term derived by higher layers from beacon function physical channel measurements. It may comprise a weighted sum of the instantaneous (L_{PCPCH}) and filtered (L_0) pathloss measurements (as described in [15])
- β_e is the gain factor derived for the selected E-TFC transport block size, E-PUCH physical resource size, E-PUCH modulation type and HARQ offset according to subclause 4.2.2.4.1.
- K_{E-PUCH} is the E-PUCH constant value signalled by higher layers [15].

Higher layers in the UE shall use the current calculated E-PUCH power in conjunction with the current absolute grant (power) value in order to determine the set of E-TFC's available (see [18]).

When setting the initial transmit power for E-PUCH or following an extended pause in the reception of TPC commands on E-AGCH, the UE shall set P_{e-base} equal to the average of the I_{BTS} values (see [15]) over the timeslots configured for E-DCH use. When receipt of TPC commands on E-AGCH recommences, the TPC commands shall be used to modify P_{e-base} from its previously set value.

4.2.2.4.1 Gain Factors for E-PUCH

A beta factor β_e shall be derived by the UE as a function of:

- the selected E-TFC transport block size
- the E-PUCH resource occupation in the E-DCH TTI
- the modulation type (QPSK/16-QAM)
- the HARQ power offset (see [18])

Higher layers shall provide a set of reference points defining the relationship between the coderate of E-DCH transmission (λ_e) and the relative reference power per resource unit (β_λ dB). A set of reference points is provided separately for each of QPSK and 16-QAM modulation.

The coderate of E-DCH transmission λ_e for the selected E-TFC, physical resource allocation and modulation type is defined as:

$$\lambda_e = \frac{S_e}{R_e}$$

... in which S_e is the transport block size of the selected E-TFC and R_e is the number of physical channel bits output from the physical channel mapping stage of E-DCH transport channel processing as described in [9].

The maximum and minimum values of λ signalled by higher layers for the appropriate modulation type are denoted λ_{max} and λ_{min} respectively. For a given λ_e there exists a λ_0 and a λ_1 such that:

- If $\lambda_{min} \leq \lambda_e < \lambda_{max}$
 - λ_0 is the largest λ signalled by higher layers for the appropriate modulation type and for which $\lambda \leq \lambda_e$
 - λ_1 is the smallest λ signalled by higher layers for the appropriate modulation type and for which $\lambda > \lambda_e$
- Else

- If $\lambda_e < \lambda_{\min}$ then $\lambda_0 = \lambda_{\min}$ and λ_1 is the smallest signalled λ for which $\lambda > \lambda_{\min}$.
- If $\lambda_e \geq \lambda_{\max}$ then λ_0 is the largest signalled λ for which $\lambda < \lambda_{\max}$ and $\lambda_1 = \lambda_{\max}$.

Associated with λ_0 and λ_1 are the corresponding β_{λ_0} and β_{λ_1} which define the reference points signalled by higher layers. The normalised (per-resource-unit) beta value for the selected E-TFC and E-PUCH resource set is denoted $\beta_{0,e}$ and is:

$$\beta_{0,e} = \beta_{\lambda_0} + \frac{\beta_{\lambda_1} - \beta_{\lambda_0}}{\lambda_1 - \lambda_0} (\lambda_e - \lambda_0) \text{ dB}$$

α_e is a logarithmic value set as a function of the E-PUCH spreading factor (SF_{E-PUCH}) according to table 1a.

Table 1a: Tabulated α_e values

SF_{E-PUCH}	α_e (dB)
1	12
2	9
4	6
8	3
16	0

β_e is then derived as
$$\beta_e = \beta_{0,e} + \alpha_e + \Delta_{harq} \text{ dB}$$

Δ_{harq} is set by higher layers (see [18]).

4.2.2.5 E-RUCCH

The transmit power for the E-RUCCH is set by higher layers based on open loop power control as described in [15].

4.2.3 Downlink Control

4.2.3.1 P-CCPCH

The Primary CCPCH transmit power is set by higher layer signalling and can be changed based on network conditions on a slow basis. The reference transmit power of the P-CCPCH is broadcast on BCH or individually signalled to each UE.

4.2.3.2 S-CCPCH, PICH

The relative transmit power of the Secondary CCPCH and the PICH compared to the P-CCPCH transmit power are set by higher layer signalling. The PICH power offset relative to the P-CCPCH reference power is signalled on the BCH.

4.2.3.2A MICH

The relative transmit power of the MICH compared to the P-CCPCH transmit power is set by higher layer signalling.

4.2.3.3 SCH

The SCH transmit power is set by higher layer signalling [16]. The value is given relative to the power of the P-CCPCH.

4.2.3.3A PNBSCH

The PNBSCH transmit power is set by higher layer signalling [16]. The value given is relative to the power of the P-CCPCH.

4.2.3.4 DPCH, PDSCH

The initial transmission power of the downlink DPCH and the PDSCH shall be set by higher layer signalling. If associated uplink CCTrCHs for TPC commands are signalled to the UE by higher layers (mandatory for a DPCH), the network shall transit into inner loop power control after the initial transmission. The UE shall then generate TPC commands to control the network transmit power and send them in the TPC field of the associated uplink CCTrCHs. If the physical channel power should be increased, the TPC command is set to “up” whereas if the power should be reduced the TPC command is set to “down”. An example on how to derive the TPC commands and the definition of the inner loop power control are given in Annex A.1. A TPC command sent in an uplink CCTrCH controls all downlink DPCHs or PDSCHs to which the associated downlink CCTrCH is mapped to.

If a PDSCH does not have associated uplink CCTrCHs configured for TPC power control, its power shall be controlled by higher layer signalling.

In the case that no associated downlink data is scheduled within 15 timeslots before the transmission of a TPC command then this is regarded as a transmission pause. The TPC commands in this case shall be derived from measurements on beacon function physical channels. An example solution for the generation of the TPC command for this case is given in Annex A.1.

When not in a transmission pause each TPC command shall always be based on all associated downlink transmissions received since the previous related TPC command. Related TPC commands are defined as TPC commands associated with the same downlink CCTrCHs. If there are no associated downlink transmissions (or equivalently no beacon transmissions when in a transmission pause) between two or more uplink transmissions carrying related TPC commands, then these TPC commands shall be identical and they shall be regarded by the UTRAN as a single TPC command.

UTRAN may decide how to adjust the transmit power in response to the received TPC command.

The UTRAN may apply an individual offset to the transmission power in each timeslot according to the downlink interference level at the UE.

The transmission power of one DPCH or PDSCH shall not exceed the limits set by higher layer signalling by means of Maximum_DL_Power (dB) and Minimum_DL_Power (dB). The transmission power is defined as the average power over one timeslot of the complex QPSK symbols of a single DPCH or PDSCH before spreading relative to the power of the P-CCPCH.

During a downlink transmission pause, both UE and Node B shall use the same TPC step size which is signalled by higher layers. The UTRAN may accumulate the TPC commands received during the pause. TPC commands that shall be regarded as identical may only be counted once. The initial UTRAN transmission power for the first data transmission after the pause may then be set to the sum of transmission power before the pause and a power offset according to the accumulated TPC commands. Additionally this sum may include a constant set by the operator and a correction term due to uncertainties in the reception of the TPC bits. The total downlink transmission power at the Node B within one timeslot shall not exceed Maximum Transmission Power set by higher layer signalling. If the total transmit power of all channels in a timeslot exceeds this limit, then the transmission power of all downlink DPCHs and PDSCHs shall be reduced by the same amount in dB. The value for this power reduction is determined, so that the total transmit power of all channels in this timeslot is equal to the maximum transmission power.

4.2.3.4.1 Out of synchronisation handling

When the dedicated physical channel out of sync criteria based on the received burst quality is as given in the subclause 4.4.2 then the UE shall set the uplink TPC command = "up". The CRC based criteria shall not be taken into account in TPC bit value setting.

4.2.3.5 HS-PDSCH

The HS-PDSCH power control is under the control of the NodeB.

4.2.3.6 HS-SCCH

Higher layers shall indicate the maximum transmit power of the HS-SCCH. The Node-B shall not exceed this maximum power when setting the HS-SCCH power.

The initial power of the HS-SCCH is at the discretion of the Node-B. Following the initial transmission, the NodeB may optionally power control the HS-SCCH. This may be done using TPC commands sent by the UE in the HS-SICH.

The UE shall set the TPC commands in the HS-SICH in order to control the transmit power of the HS-SCCH. The TPC commands shall be set in order to meet the HS-SCCH target BLER.

The accuracy of the received HS-SCCH BLER estimate made by the UE may be enhanced by a suitable use of the HCSN field received within the HS-SCCH itself [9]. This field shall initially be set to zero and shall be incremented by the NodeB each time an HS-SCCH is transmitted to the UE.

4.2.3.7 E-AGCH

Higher layers shall indicate the maximum transmit power of the E-AGCH. The Node-B shall not exceed this maximum power when setting the E-AGCH power.

The initial power of the E-AGCH is at the discretion of the Node-B. Following the initial transmission, the NodeB may optionally power control the E-AGCH. This may be done using TPC commands sent by the UE in the E-PUCH.

The UE shall set the TPC commands in the E-PUCH in order to control the transmit power of the E-AGCH. The TPC commands shall be set in order to meet the E-AGCH target BLER.

The accuracy of the received E-AGCH BLER estimate made by the UE shall be enhanced by a suitable use of the ECSN field received within the E-AGCH itself [9]. This field shall initially be set to zero and shall be incremented by the Node-B each time an E-AGCH is transmitted to the UE.

4.2.3.8 E-HICH

The power of the E-HICH is under the control of the Node B.

4.3 Timing Advance

UTRAN may adjust the UE transmission timing with timing advance. The initial value for timing advance (TA_{phys}) will be determined in the UTRAN by measurement of the timing of the PRACH or E-RUCCH. The required timing advance will be represented as an 8 bit number (0-255) 'UL Timing Advance' TA_{ul} , being the multiplier of 4 chips which is nearest to the required timing advance (i.e. $TA_{phys} = TA_{ul} \times 4$ chips).

When Timing Advance is used the UTRAN will continuously measure the timing of a transmission from the UE and send the necessary timing advance value. On receipt of this value the UE shall adjust the timing of its transmissions accordingly in steps of ± 4 chips. The transmission of TA values is done by means of higher layer messages. Upon receiving the TA command the UE shall adjust its transmission timing according to the timing advance command at the frame number specified by higher layer signaling. The UE is signaled the TA value in advance of the specified frame activation time to allow for local processing of the command and application of the TA adjustment on the specified frame. Node-B is also signaled the TA value and radio frame number that the TA adjustment is expected to take place.

If TA is enabled by higher layers, after handover the UE shall transmit in the new cell with timing advance TA adjusted by the relative timing difference Δt between the new and the old cell:

$$TA_{\text{new}} = TA_{\text{old}} + 2\Delta t.$$

4.4 Synchronisation procedures

4.4.1 Cell Search

During the cell search, the UE searches for a cell and determines the downlink scrambling code, basic midamble code and frame synchronisation of that cell. How cell search is typically done is described in Annex C.

For MBSFN FACH, the downlink scrambling codes and basic midamble codes to be used for non-beacon timeslots are signalled by higher layers.

4.4.2 Dedicated channel synchronisation

4.4.2.1 Synchronisation primitives

4.4.2.1.1 General

For the dedicated channels, synchronisation primitives are used to indicate the synchronisation status of radio links, both in uplink and downlink. The definition of the primitives is given in the following subclauses.

When operating HS-DSCH, the configuration of a downlink DPCH by UTRAN is optional. Subclause 4.4.2.1.2 relates to downlink synchronisation in the case that an uplink and downlink DPCH have been configured by higher layers. Subclause 4.4.2.1.2A relates to downlink synchronisation in the case that only an uplink DPCH has been configured by higher layers.

4.4.2.1.2 Downlink synchronisation primitives

Layer 1 in the UE shall check the synchronization status of each DL CCTrCH individually in every radio frame. All bursts and transport channels of a CCTrCH shall be taken into account. Synchronisation status is indicated to higher layers, using the CPHY-Sync-IND or CPHY-Out-of-Sync-IND primitives. For dedicated physical channels configured with Repetition Periods [15] only the configured active periods shall be taken into account in the estimation. The status check shall also include detection of the Special Bursts defined in 4.5 for DTX.

The criteria for reporting synchronization status are defined in two different phases.

The first phase lasts until 160 ms after the downlink CCTrCH is considered to be established by higher layers. During this time, Out-of-sync shall not be reported. In-sync shall be reported using the CPHY-Sync-IND primitive if any one of the following three criteria is fulfilled.

- a) The UE estimates the burst reception quality over the previous 40 ms period to be better than a threshold Q_{in} . This criterion shall be assumed not to be fulfilled before 40 ms of burst reception quality measurement have been collected.
- b) At least one transport block with a CRC attached is received in a TTI ending in the current frame with correct CRC.
- c) The UE detects at least one Special Burst. Special Burst detection shall be successful if the burst is detected with quality above a threshold, Q_{sbin} , and the TFCI is decoded to be that of the Special Burst.

The second phase starts 160 ms after the downlink dedicated channel is considered established by higher layers.. During this phase both Out-of-Sync and In-Sync are reported as follows.

Out-of-sync shall be reported using the CPHY-Out-of-Sync-IND primitive if all three of the following criteria are fulfilled:

- the UE estimates the received dedicated channel burst quality over the last 160 ms period to be worse than a threshold Q_{out} . The value, Q_{out} is defined implicitly by the relevant tests in [2];
- no Special Burst is detected with quality above a threshold Q_{sboot} within the last 160 ms period. The value Q_{sboot} is defined implicitly by the relevant tests in [2];

- over the previous 160 ms, no transport block has been received with a correct CRC

If the UE detects the beacon channel reception level [10 dB] above the handover triggering level, the UE shall use 320 ms estimation period for the burst quality evaluation and for the Special Burst and CRC detection window.

In-sync shall be reported using the CPHY-Sync-IND primitive if any of the following criteria is fulfilled:

- the UE estimates the received burst reception quality over the last 160 ms period to be better than a threshold Q_{in} . The value, Q_{in} is defined implicitly by the relevant tests in [2].
- the UE detects at least one Special Burst with quality above a threshold Q_{sbin} within the last 160 ms period. The value, Q_{sbin} , is defined implicitly by the relevant tests in [2].
- at least one transport block with a CRC attached is received in a TTI ending in the current frame with correct CRC.

If the UE detects the beacon channel reception level [10 dB] above the handover triggering level, the UE uses 320 ms estimation period for the burst quality evaluation and for the Special Burst detection window.

If no data are provided by higher layers for transmission during the second phase on the downlink dedicated channel then DTX shall be applied as defined in section 4.5.

How the primitives are used by higher layers is described in [15]. The above definitions may lead to radio frames where neither the In-Sync nor Out-of-Sync primitives are reported.

4.4.2.1.2A Downlink synchronisation primitives for HS-channels

In the case that an uplink DPCH has been configured by higher layers but a downlink DPCH has not been configured, the UE shall report downlink synchronisation status based upon other downlink physical channels.

The UE shall monitor the received beacon signal level within the cell and shall average the received beacon power over a period of 160ms. This averaged value is denoted P_b dBm. The UE shall also monitor and average over the same period, the ISCP on the assigned HS-SCCH resources. This value is denoted $I_{HS-SCCH}$ dBm. A quality value Q_{hs} is formed as follows:

$$Q_{hs} = P_b - I_{HS-SCCH} + D_{hs-sync}$$

- where $D_{hs-sync}$ is signalled by higher layers.

In-sync shall be reported using the CPHY-Sync-IND primitive each time an HS-DSCH CRC pass is detected. On this event, an indicator maintained by the UE termed "HS-DSCH_failure" shall be set to 'false'. In-sync shall also be reported if the HS-DSCH_failure indicator is set to 'false' and during the last 160ms period, $Q_{hs} > Q_{hsin}$, where Q_{hsin} is a quality threshold defined implicitly by the relevant tests in [2].

Out-of-sync shall be reported using the CPHY-Out-of-Sync-IND primitive. "Out-of-sync" is generated in the event that, during the last 160ms period, $Q_{hs} < Q_{hsout}$, where Q_{hsout} is a quality threshold defined implicitly by the relevant tests in [2]. CPHY-Out-of-Sync-IND shall also be generated in the event of 16 successive HS-DSCH CRC failures. On occurrence of this event, the HS-DSCH_failure indicator shall be set to 'true'.

How the primitives are used by higher layers is described in [15]. The above definitions may lead to radio frames where neither the In-Sync nor Out-of-Sync primitives are reported. They may also, under some circumstances, lead to radio frames in which both In-Sync and Out-of-Sync primitives are generated. In this instance, In-sync shall override Out-of-Sync and the Out-of-Sync primitive shall not be reported.

4.4.2.1.3 Uplink synchronisation primitives

Layer 1 in the Node B shall every radio frame check synchronisation status, individually for each UL CCTrCH of the radio link. Synchronisation status is indicated to the RL Failure/Restored triggering function using either the CPHY-Sync-IND or CPHY-Out-of-Sync-IND primitive.

The exact criteria for indicating in-sync/out-of-sync is not subject to specification, but could e.g. be based on received burst quality or CRC checks. One example would be to have the same criteria as for the downlink synchronisation status primitives.

4.4.2.2 Radio link monitoring

4.4.2.2.1 Downlink radio link failure

The downlink CCTrCHs are monitored by the UE, to trigger radio link failure procedures. The downlink CCTrCH failure status is specified in [15], and is based on the synchronisation status primitives CPHY-Sync-IND and CPHY-Out-of-Sync-IND, indicating in-sync and out-of-sync respectively. These primitives shall provide status for each DL CCTrCH separately.

4.4.2.2.2 Uplink radio link failure/restore

The uplink CCTrCHs are monitored by the Node B in order to trigger CCTrCH failure/restore procedures. The uplink CCTrCH failure/restore status is reported using the synchronisation status primitives CPHY-Sync-IND and CPHY-Out-of-Sync-IND, indicating in-sync and out-of-sync respectively.

When the CCTrCH is in the in-sync state, Node B shall start timer T_RLFAILURE after receiving N_OUTSYNC_IND consecutive out-of-sync indications. Node B shall stop and reset timer T_RLFAILURE upon receiving successive N_INSYNC_IND in-sync indications. If T_RLFAILURE expires, Node B shall indicate to higher layers which CCTrCHs are out-of-sync using the synchronization status primitives. Furthermore, the CCTrCH state shall be changed to the out-of-sync state.

When a CCTrCH is in the out-of-sync state, after receiving N_INSYNC_IND successive in-sync indications Node B shall indicate that the CCTrCH has re-established synchronisation and the CCTrCH's state shall be changed to the in-sync-state. The specific parameter settings (values of T_RLFAILURE, N_OUTSYNC_IND, and N_INSYNC_IND) are configurable, see [16].

4.5 Discontinuous transmission (DTX) procedure

The DTX procedure shall be applied for CCTrCHs mapped to S-CCPCH, UL DPCH, DL DPCH, PUSCH and PDSCH, if the total bit rate of the CCTrCH differs from the total channel bit rate of the physical channels allocated to this CCTrCH. DTX shall not be applied to E-DCH mapped to E-PUCH.

The DTX procedure shall also be applied to HS-PDSCHs, HS-SCCHs, E-AGCHs and E-HICHs if no data is to be transmitted on these physical channels in a given TTI.

Rate matching is used in order to fill resource units completely, that are only partially filled with data. In the case that after rate matching and multiplexing no data at all is to be transmitted in a resource unit the complete resource unit shall be discarded from transmission (DTX), unless a Special Burst is transmitted in the RU. This applies also to the case where only one resource unit is allocated and no data has to be transmitted.

4.5.1 Description of Special Bursts

For S-CCPCH, UL DPCH, DL DPCH, PUSCH and PDSCH, the Special Burst has the same timeslot format as the burst used for data provided by higher layers. If the timeslot format contains a TFCI field, then the TFCI field shall be filled with "0" bits. The Special Burst may also carry layer 1 control symbols such as TPC bits for the purposes of inner-loop power control. The data portions of the Special Burst are filled with an arbitrary bit pattern.

For S-CCPCH, UL DPCH, DL DPCH, PUSCH and PDSCH, the transmission power of the special burst shall be the same as that of the substituted physical channel of the CCTrCH. In the case of uplink physical channels where autonomous spreading factor change by the UE is permitted by higher layers, the substituted physical channel is considered to be that which would have been employed for the lowest non-zero rate TFC within the set of allowed TFC's and the transmission power of the Special Burst shall again correspond to that of the physical channel substituted.

For HS-PDSCH, the Special Burst shall use the timeslot format #0 from table 7a, see section 5.3.9.5 in [8]. For HS-SCCH, the Special Burst shall use timeslot format #0 from table 5a, see section 5.2.2.6.1 in [8]. The Special Burst is filled with an arbitrary bit pattern. The transmission power of the Special Burst shall be the same as that of the substituted Beacon channel.

4.5.2 Use of Special Bursts during DTX

In the case that after link establishment there are no transport blocks provided for transmission by higher layers for a given CCTrCH mapped to UL DPCH, DL DPCH, PUSCH or PDSCH physical channels, then a Special Burst shall be transmitted in the first allocated frame of the transmission pause. If, including the first frame, there is a consecutive period of Special Burst Period (SBP) frames without transport blocks provided by higher layers, then another special burst shall be generated and transmitted at the next possible frame. This pattern shall be continued until transport blocks are provided for the CCTrCH by the higher layers. SBP shall be provided by higher layers. The value of SBP shall be independently specified for uplink and for downlink and shall be designated as

SBGP (special burst generation period) for uplink transmissions

SBSP (special burst scheduling parameter) for downlink transmissions

The default value for both SBGP and SBSP shall be 8.

The Special Burst shall be transmitted using the physical channel with the lowest physical channel sequence number (p) as defined by the rate matching function in [9].

Special Bursts shall not be transmitted for HS-SCCH and for CCTrCHs mapped to S-CCPCH or HS-PDSCH in non-Beacon locations, i.e. only DTX shall be applied to these physical channels.

4.5.3 Use of Special Bursts for Initial Establishment / Reconfiguration

Upon initial establishment or reconfiguration for either 160 ms following detection of in-sync, or until the first transport block is received from higher layers, both the UE and the Node B shall transmit the special burst for each CCTrCH mapped to UL DPCH, DL DPCH, PUSCH and PDSCH physical channels.

The Special Burst shall be transmitted using the physical channel with the lowest physical channel sequence number (p) as defined by the rate matching function in [9].

4.5.4 Use of Special Bursts for DTX on Beacon Channels

In the case that a beacon-function physical channel (S-CCPCH or PDSCH) would be DTX'd, then a Special Burst shall be transmitted on the Beacon Channel in that frame instead in order to maintain the beacon functionality.

4.6 Downlink Transmit Diversity

Downlink transmit diversity for PDSCH, DPCH, P-CCPCH, S-CCPCH, PICH, MICH, HS-SCCH, HS-PDSCH, E-AGCH, E-HICH and SCH is optional in UTRAN. Its support is mandatory at the UE.

4.6.1 Transmit Diversity for PDSCH, DPCH, HS-SCCH, HS-PDSCH and E-AGCH

The transmitter structure to support transmit diversity for PDSCH, DPCH, HS-SCCH, HS-PDSCH and E-AGCH transmission is shown in figure 1. Channel coding, interleaving and spreading are done as in non-diversity mode. The spread complex valued signal is fed to both TX antenna branches, and weighted with antenna specific weight factors w_1 and w_2 . The weight factors are complex valued signals (i.e., $w_i = a_i + jb_i$), in general. These weight factors are calculated on a per slot and per user basis.

The weight factors are determined by the UTRAN. Examples of transmit diversity schemes are given in annex B.

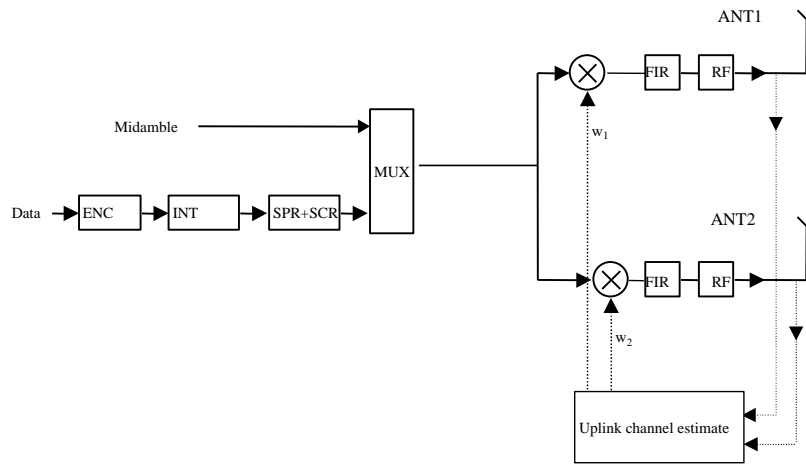

Figure 1: Downlink transmitter structure to support Transmit Diversity for PDSCH, DPCH, HS-SCCH, HS-PDSCH and E-AGCH transmission (UTRAN Access Point)

4.6.2 Transmit Diversity for SCH and S-CCPCH

Time Switched Transmit Diversity (TSTD) can be employed as a transmit diversity scheme for the synchronisation channel and/or S-CCPCH.

4.6.2.1 SCH Transmission Scheme

The transmitter structure to support transmit diversity for SCH transmission is shown in figure 2. P-SCH and S-SCH are transmitted from antenna 1 and antenna 2 alternatively. An example for the antenna switching pattern is shown in figure 3.

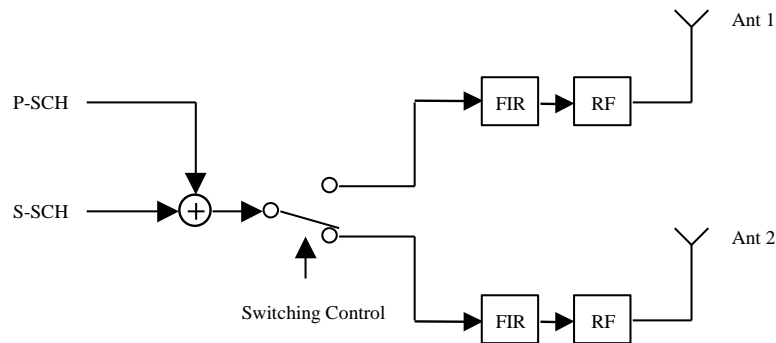

Figure 2: Downlink transmitter structure to support Transmit Diversity for SCH transmission (UTRAN Access Point)

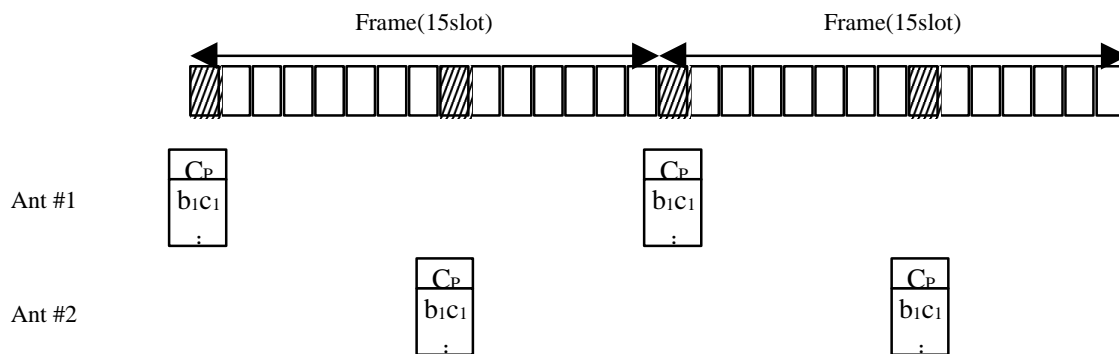

Figure 3: Antenna Switching Pattern (Case 2)

4.6.2.2 S-CCPCH Transmission Scheme

The transmitter structure to support TSTD for S-CCPCH is shown in figure 3a. The antenna switching pattern is under the control of the Node-B and is not explicitly known to the UE. Switching may only be performed during the guard periods between timeslots.

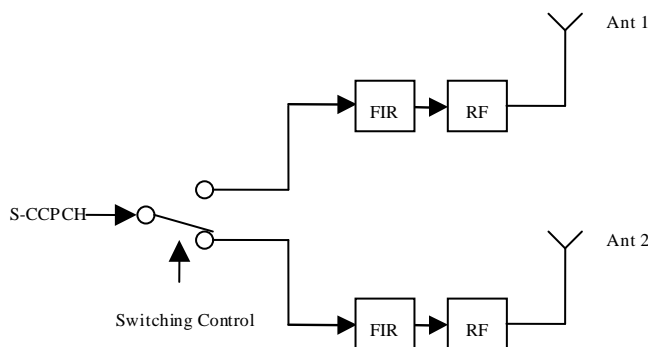

Figure 3a: Downlink transmitter structure to support TSTD for S-CCPCH transmission (UTRAN Access Point)

4.6.3 Transmit Diversity for Beacon Channels

When beacon channels use burst type 4, SCTD shall not be applied.

When beacon channels use burst type 1, Space Code Transmit Diversity (SCTD) for beacon channels may be employed optionally in the UTRAN. The support is mandatory in the UE except for the case where the UE only supports burst type 4. The use of SCTD will be indicated by higher layers. If SCTD is active within a cell:

- SCTD shall be applied to any beacon channel, and
- the maximum number K_{Cell} of midambles for burst type 1 that are supported in this cell may be 8 or 16, see [8]. The case of $K_{Cell} = 4$ midambles is not allowed for this burst type.

4.6.3.1 SCTD Transmission Scheme

The open loop downlink transmit diversity scheme for beacon channels is shown in figure 4. Channel coding, rate matching, interleaving and bit-to-symbol mapping are performed as in the non-diversity mode. In Space Code Transmit

Diversity mode the data sequence is spread with the channelisation codes $c_{16}^{(k=1)}$ and $c_{16}^{(k=2)}$ and scrambled with the cell specific scrambling code. The spread sequence on code $c_{16}^{(k=2)}$ is then transmitted on the diversity antenna. The power applied to each antenna shall be equal.

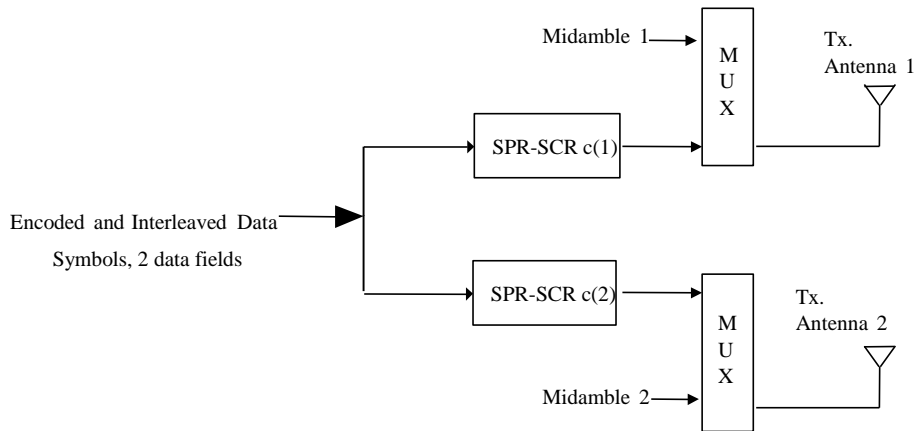

Figure 4: Block Diagram of the transmitter SCTD

4.7 Random access procedure

The physical random access procedure described below is invoked whenever a higher layer requests transmission of a message on the RACH. The physical random access procedure is controlled by primitives from RRC and MAC. Retransmission on the RACH in case of failed transmission (e.g. due to a collision) is controlled by higher layers. Thus, the backoff algorithm and associated handling of timers is not described here. The definition of the RACH in terms of PRACH Access Service Classes is broadcast on the BCH in each cell. Parameters for common physical channel uplink outer loop power control are also broadcast on the BCH in each cell. The UE needs to decode this information prior to transmission on the RACH. Higher layer signalling may indicate, that in some frames a timeslot shall be blocked for RACH uplink transmission.

4.7.1 Physical random access procedure

The physical random access procedure described in this subclause is initiated upon request from the MAC sublayer (see [18] and [19]).

Note: The selection of a PRACH is done by the RRC Layer.

Before the physical random-access procedure can be initiated, Layer 1 shall receive the following information from the RRC layer using the primitives CPHY-TrCH-Config-REQ and CPHY-RL-Setup/Modify-REQ.

- the available PRACH channelization codes (There is a 1-1 mapping between the channelization code and the midamble shift as defined by RRC) for each Access Service Class (ASC) of the selected PRACH (the selection of a PRACH is done by the RRC). CPHY-RL-Setup/Modify-REQ);
- the timeslot, spreading factor, and midamble type(direct or inverted) for the selected PRACH (CPHY-RL-Setup/Modify-REQ);
- the RACH Transport Format (CPHY-TrCH-Config-REQ);
- the RACH transport channel identity (CPHY-TrCH-Config-REQ)
- the set of parameters for common physical channel uplink outer loop power control(CPHY-RL-Setup/Modify-REQ).

NOTE: The above parameters may be updated from higher layers before each physical random access procedure is initiated.

At each initiation of the physical random access procedure, Layer 1 shall receive the following information from the MAC:

- the ASC of the PRACH transmission;
- the data to be transmitted (Transport Block Set).

the selected ASC sub-channel. The ASC subchannel is defined in reference [18]. The value is passed in the PHY-Data-REQ is the CFN_{CELL} .

In addition, Layer 1 may receive information from higher layers, that a timeslot in certain frames shall be blocked for PRACH uplink transmission.

The physical random-access procedure shall be performed as follows:

- 1 Randomly select one channelization code from the set of available codes for the selected ASC. The random function shall be such that each code is chosen with equal probability.
- 2 Determine the midamble shift to use, based on the selected channelization code.
- 3 Set the PRACH message transmission power level according to the specification for common physical channels in uplink (see subclause 4.2.2.2).
- 4 Transmit the RACH Transport Block Set (the random access message) with no timing advance in the selected sub-channel using the selected channelization code.

4.7A E-RUCCH transmission procedure

Requests for the transmission of an E-RUCCH are controlled by higher layers [18].

The E-RUCCH random access procedure shall be performed as follows:

- 1 Randomly select one channelization code from the set of available codes for E-RUCCH. The random function shall be such that each code is chosen with equal probability.
- 2 Determine the midamble shift to use, based on the selected channelization code.
- 3 Set the E-RUCCH message transmission power level according to subclause 4.2.2.5.
- 4 Transmit the E-RUCCH with no timing advance using the selected channelization code.

4.8 DSCH procedure

The physical downlink shared channel procedure described below shall be applied by the UE when the physical layer signalling either with the midamble based signalling or TFCI based signalling is used to indicate for the UE the need for PDSCH detection. There is also a third alternative to indicate to the UE the need for the PDSCH detection and this is done by means of higher layer signalling, already described in [8].

4.8.1 DSCH procedure with TFCI indication

When the UE has been allocated by higher layers to receive data on DSCH using the TFCI, the UE shall decode the PDSCH in the following cases:

- In case of a standalone PDSCH the TFCI is located on the PDSCH itself, then the UE shall decode the TFCI and based on which data rate was indicated by the TFCI, the decoding shall be performed. The UE shall decode PDSCH only if the TFCI word decode corresponds to the TFC part of the TFCS given to the UE by higher layers.
- In case that the TFCI is located on the DCH, the UE shall decode the PDSCH frame or frames if the TFCI on the DCH indicates the need for PDSCH reception. Upon reception of the DCH time slot or time slots, the PDSCH slot (or first PDSCH slot) shall start $SFN\ n+2$ after the DCH frame containing the TFCI, where n indicates the SFN on which the DCH is received. In the case that the TFCI is repeated over several frames, the PDSCH slot shall start $SFN\ n+2$ after the frame having the DCH slot which contains the last part of the repeated TFCI.

4.8.2 DSCH procedure with midamble indication

When the UE has been allocated by higher layers to receive PDSCH based on the midamble used on the PDSCH (midamble based signalling described in [8]), the UE shall operate as follows:

- The UE shall test the midamble it received and if the midamble received was the same as indicated by higher layers to correspond to PDSCH reception, the UE shall detect the PDSCH data according to the TF given by the higher layers for the UE.
- In case of multiple time slot allocation for the DSCH indicated to be part of the TF for the UE, the UE shall receive all timeslots if the midamble of the first timeslot of PDSCH was the midamble indicated to the UE by higher layers.
- In case the standalone PDSCH (no associated DCH) contains the TFCI the UE shall detect the TF indicated by the TFCI on PDSCH.

4.9 Node B Synchronisation Procedure over the Air

An option exists to use cell sync bursts to achieve and maintain Node B synchronisation [20]. This optional procedure is based on transmissions of cell synchronisation bursts [10] in predetermined timeslots normally assigned to contain PRACH, according to an RNC schedule. Such soundings between neighbouring cells facilitate timing offset measurements by the cells. The timing offset measurements are reported back to the RNC for processing. The RNC generates cell timing updates that are transmitted to the Node Bs and cells for implementation.

When Cell Sync Bursts are used to achieve and maintain intercell Synchronisation there are three distinct phases, with a potential additional sub-phase involving late entrant cells.

4.9.1 Frequency Acquisition Phase

The frequency acquisition phase is used to bring cells of an RNS area to within frequency limits prior to initial synchronisation. No traffic is supported during this phase. In this phase cell(s) identified as master time reference shall transmit cell sync bursts [10] specified by higher layers continuously, i. e. one in every timeslot. All other cells shall listen for transmissions and shall perform frequency locking to the transmissions received. They shall signal completion of frequency acquisition to the RNC and begin continuous transmission of cell sync bursts specified by higher layers.

4.9.2 Initial Synchronisation

For Initial Phase, where no traffic is supported, the following procedure for initial synchronisation may be used to bring cells of an RNS area into synchronisation at network start up. In this phase each cell shall transmit cell sync bursts [10] according to the higher layer command. All cells use the same cell sync burst code and code offset. Each cell shall listen for transmissions from other cells. Each cell shall report the timing and received SIR of successfully detected cell sync bursts to the RNC. The RNC uses these measurements to adjust the timing of each cell to achieve the required synchronisation accuracy.

4.9.3 Steady-State Phase

The steady-state phase is used to maintain the required synchronisation accuracy. With the start of the steady-state phase, traffic is supported in a cell. A procedure that may be used for the steady-state phase involves cell sync bursts [10] that are transmitted and received without effect on existing traffic. Higher layers signal the transmit parameters, i.e., when to transmit which code and code offset, and which transmit power to use. The higher layers also signal to appropriate cells the receive parameters i. e. which codes and code offsets to measure in a certain timeslot. Upon determination of errors in timing, the RNC may adjust the timing of a cell or cells.

4.9.4 Late entrant cells

A procedure that may be used for introducing new cells into an already synchronised RNS involves the one time transmission of a single cell sync burst [10] (scheduled by higher layers) by all neighbour cells of the late entrant cell.

and received by the late entrant cell. The RNC may use this information to adjust the late entrant cell sufficiently to allow the cell to enter steady state phase.

4.10 Idle periods for IPDL location method

4.10.1 General

To support time difference measurements for location services, idle periods can be created in the downlink (hence the name IPDL) during which time transmission of all channels from a Node B is temporarily ceased, except for the SCH transmission. During these idle periods the visibility of neighbour cells from the UE is improved.

The idle periods are arranged in a determined pattern according to higher layer parameters. An idle period has a duration of one time slot. During idle periods only the SCH is transmitted. No attempt is made to prevent data loss.

In general there are two modes for these idle periods:

- Continuous mode, and
- Burst mode.

In continuous mode the idle periods are active all the time. In burst mode the idle periods are arranged in bursts where each burst contains enough idle periods to allow a UE to make sufficient measurements for its location to be calculated. The bursts are separated by a period where no idle periods occur.

The time difference measurements can be performed on any channel. If the P-CCPCH falls in an idle slot, UTRAN may decide not to transmit the P-CCPCH in two consecutive frames, the first of these two frames containing the idle slot. This option is signalled by higher layers.

4.10.2 Parameters of IPDL

The following parameters are signalled to the UE via higher layers:

IP_Status:	This is a logic value that indicates if the idle periods are arranged in continuous or burst mode.
IP_Spacing:	The number of 10 ms radio frames between the start of a radio frame that contains an idle period and the next radio frame that contains the next idle period. Note that there is at most one idle period in a radio frame.
IP_Start:	The number of the first frame with idle periods. In case of continuous mode IP_Start is the SFN of the first frame with idle periods and in case of burst mode IP_Start defines the number of frames after Burst_Start with the first frame with idle periods.
IP_Slot:	The number of the slot that has to be idle [0..14].
IP_PCCPCH:	This logic value indicates, if the P-CCPCH is switched off in two consecutive frames. The first of these two frames contains the idle period.

Additionally in the case of burst mode operation the following parameters are also communicated to the UE.

Burst_Start:	Specifies the start of the first burst of idle periods. $256 \times \text{Burst_Start}$ is the SFN where the first burst of idle periods starts.
Burst_Length:	The number of idle periods in a burst of idle periods.
Burst_Freq:	Specifies the time between the start of a burst and the start of the next burst. $256 \times \text{Burst_Freq}$ is the number of radio frames between the start of a burst and the start of the next burst.

4.10.3 Calculation of idle period position

In burst mode, burst #0 starts in the radio frame with $\text{SFN} = 256 \times \text{Burst_Start}$. Burst #n starts in the radio frame with $\text{SFN} = 256 \times \text{Burst_Start} + n \times 256 \times \text{Burst_Freq}$ ($n = 0, 1, 2, \dots$). The sequence of bursts according to this formula continues up to and including the radio frame with $\text{SFN} = 4095$. At the start of the radio frame with $\text{SFN} = 0$, the burst

sequence is terminated (no idle periods are generated) and at $SFN = 256 \times \text{Burst_Start}$ the burst sequence is restarted with burst #0 followed by burst #1 etc., as described above.

Continuous mode is equivalent to burst mode, with only one burst spanning the whole SFN cycle of 4096 radio frames, this burst starts in the radio frame with $SFN = 0$. In case of continuous mode the parameter IP_Start defines the first frame with idle periods.

The position of an idle period is defined by two values: $IP_Frame(x)$ and IP_Slot . $IP_Frame(x)$ defines the x^{th} frame within a burst that contains the idle period. IP_Slot defines the slot in that frame during which no transmission takes place except for the SCH.

The actual frame with idle periods within a burst is calculated as follows:

$$IP_Frame(x) = IP_Start + (x-1) \times IP_Spacing \text{ with } x = 1, 2, 3, \dots$$

If the parameter IP_PCCPCH is set to 1, then the P-CCPCH will not be transmitted in the frame $IP_Frame(x) + 1$ within a burst.

Figure 5 below illustrates the idle periods for the burst mode case, if the $IP_P-CCPCH$ parameter is set to 0.

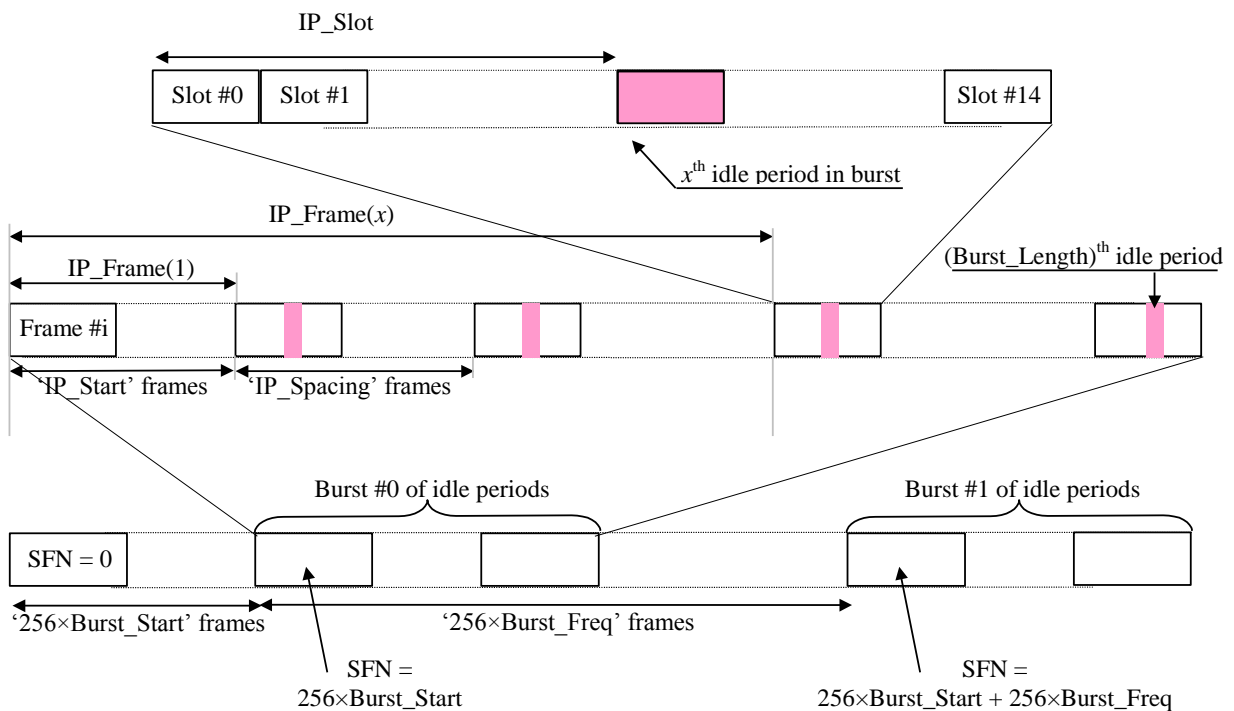

Figure 5: Idle Period placement in the case of burst mode operation with $IP_P-CCPCH$ parameter set to 0

4.11 HS-DSCH Procedure

4.11.1 Link Adaptation Procedure

For HS-DSCH, the modulation scheme and effective code rate shall be selected by higher layers located within the NodeB. This shall be achieved by appropriate selection of an HS-DSCH transport block size, modulation format and resources by higher layers. Selection of these parameters may be based on CQI reports from the UE.

The overall HS-DSCH link adaptation procedure consists of *two parts*:

Node B procedure:

- 1) The NodeB shall transmit HS-SCCH carrying a UE identity identifying the UE for which HS-DSCH TTI allocation has been given. In the case of HS-DSCH transmissions in consecutive TTIs to the same UE, the same HS-SCCH shall be used for associated signalling.
- 2) The NodeB transmits HS-DSCH to the UE using the resources indicated in the HS-SCCH.
- 3) Upon receiving the HS-SICH from the respective UE, the status report (ACK/NA CK and CQI) shall be passed to higher layers.

UE procedure:

- 1) When indicated by higher layers, the UE shall start monitoring all HS-SCCHs that are in its HS-SCCH set as signalled to it by higher layers. The information carried on the HS-SCCH is described in [8].
- 2) In the case that a HS-SCCH is identified to be correct by its CRC, the UE shall read the HS-PDSCHs indicated by the HS-SCCH. In the case that a HS-SCCH is identified to be incorrect, the UE shall discard the data on the HS-SCCH and return to monitoring.
- 3) After reading the HS-PDSCHs, the UE shall generate an ACK/NA CK message and transmit this to the NodeB in the associated HS-SICH, along with the most recently derived CQI.

The mapping of HS-PDSCH channelisation code set and timeslot information carried by the HS-SCCH for a given HS-DSCH TTI is described in [9].

For a given allocation of HS-PDSCH resources to a UE for a specific HS-DSCH TTI, the following shall apply:

- If timeslot information on HS-SCCH indicates two or more timeslots, none of these timeslots shall comprise a beacon channel.
- If timeslot information on HS-SCCH indicates a single timeslot and this timeslot comprises a beacon channel then:
 - The Node-B shall not indicate SF=1 for any HS-PDSCH resource.
 - The set of HS-PDSCH resources allocated by the Node-B to a UE shall exclusively comprise either beacon function or non-beacon function physical channels. The Node B shall therefore not allocate both beacon function and non-beacon function physical channels within the beacon timeslot to the UE. If the HS-DSCH for a specific HS-DSCH TTI is mapped to the beacon channel, this shall be signalled using $k_{start} = 1$ and $k_{stop} = 1$. For a definition of the first and last allocated channelisation code indices k_{start} and k_{stop} on HS-SCCH refer to [9].
 - When SCTD antenna diversity is applied to the beacon channel, then the presence of channelisation code $C_{16}^{(1)}$ within the channelisation code set information on HS-SCCH shall implicitly indicate the presence of channelisation code $C_{16}^{(2)}$.

4.11.2 HS-DSCH Channel Quality Indication Procedure

The channel quality indicator (CQI) provides the NodeB with an estimate of the code rate that would have maximised the single-transmission throughput of the previous HS-DSCH transmission if decoded in isolation. The CQI report requires to be referenced to a given set of HS-PDSCH resources by the NodeB, but note that the UE is not restricted to making measurements only on these reference resources when deriving a given CQI. The reference resources for a CQI report shall be a set of HS-PDSCH resources that were received by the UE in a single TTI, and contain a complete transport block. These resources will be known to the NodeB from the relative timings of the HS-SICH carrying the CQI and previous HS-DSCH transmissions to the UE.

The CQI consists of two fields; a Recommended Transport Block Size (RTBS) and a Recommended Modulation Format (RMF). The UE shall use the same mapping table for these fields as is being used for the time slot information and modulation scheme information fields respectively of the HS-SCCH [18].

The reporting procedure is as follows:

1. The UE receives a message on an HS-SCCH telling it which resources have been allocated to it for the next associated HS-DSCH transmission.

2. The UE reads the associated HS-DSCH transmission, and makes the necessary measurements to derive a CQI that it estimates would have given it the highest single-transmission throughput for the allocated resources whilst achieving a BLER of no more than 10 %.

BLER, in this context, is defined as the probability that a transport block transmitted using the RTBS and RMF is received in error if decoded in isolation. For the purposes of this calculation, it shall be assumed that the transport block that would be transmitted with these parameters would use redundancy version parameters $s = 1$ and $r = 0$. Note that, by this definition, a UE shall never report a CQI that corresponds to a code rate greater than unity.

Using this definition of BLER, single-transmission throughput shall be defined as follows :

$$\text{single-transmission throughput} = (1 - \text{BLER}) \times \text{RTBS}$$

3. The CQI report derived from a given HS-DSCH transmission shall be reported to the NodeB in the next HS-SICH available to the UE following that HS-DSCH transmission, unless that HS-SICH immediately follows the last allocated HS-DSCH timeslot, in which case the subsequent available HS-SICH shall be used by the UE. This HS-SICH may not necessarily be the same HS-SICH that carries the ACK/NACK information for that HS-DSCH transmission. The UE shall always transmit the most recently derived CQI in any given HS-SICH, which may mean that some CQI reports are discarded without being transmitted to the NodeB.

4.12 Macro-diversity procedure

When signalled by higher layers, the UE shall combine transmissions on signalled transport channels from multiple radio links. UTRAN shall only indicate that a transport channel on a radio link may be combined with a transport channel on another radio link when those transport channels do not occupy the same time slot. UTRAN shall transmit identical transport blocks on the multiple radio links on the transport channels that may be combined. UTRAN may multiplex onto a CCTrCH other transport channels with transport channels that can be combined. The TTIs of transmissions that may be combined shall start at the same SFN on each of the multiple radio links.

4.13 E-DCH related procedures

4.13.1 ACK/NACK detection

The physical layer in the UE shall detect ACK or NACK contained within the E-HICH. Which E-HICH is associated with the corresponding E-DCH transmission is defined in [8].

4.13.2 Serving and neighbour cell pathloss metric derivation

The UE shall be capable of measuring the P-CCPCH RSCP of the serving cell and of intra-frequency neighbour cells in accordance with [11]. The P-CCPCH transmit power (P_{ref}) of the serving cell and of each intra-frequency neighbour cell in the monitored neighbour cell list shall be signalled by higher layers to the UE in order that the UE may estimate the mean pathloss to the serving cell (L_{serv}) and to each of the N neighbour cells in the monitored neighbour cell list (L_1, L_2, \dots, L_N).

Higher layers shall configure the UE to use SNPL reporting type 1 or SNPL reporting type 2. In accordance with the SNPL reporting type, the UE shall be capable of forming a metric corresponding to:

$$\Phi = \frac{1}{\sum_{n=1}^N L_{\text{serv}} / L_n} \quad \{\text{for SNPL reporting type 1}\}$$

$$\Phi = \frac{\min_{n=1..N}(L_n)}{L_{\text{serv}}} \quad \{\text{for SNPL reporting type 2}\}$$

The metric ϕ shall be converted into a logarithmic (dB) value Q and shall be mapped to a Serving and Neighbour Cell Pathloss (SNPL) index according to table 1b. The SNPL index is supplied to and used by higher layers (see [18]).

Table 1b: SNPL mapping

$Q = 10 \cdot \log_{10}(\phi)$	SNPL index
$Q < -6$	0
$-6 \leq Q < -5$	1
$-5 \leq Q < -4$	2
$-4 \leq Q < -3$	3
$-3 \leq Q < -2$	4
$-2 \leq Q < -1$	5
$-1 \leq Q < 0$	6
$0 \leq Q < 1$	7
$1 \leq Q < 2$	8
$2 \leq Q < 3$	9
$3 \leq Q < 4$	10
$4 \leq Q < 5$	11
$5 \leq Q < 6$	12
$6 \leq Q < 7$	13
$7 \leq Q < 8$	14
$8 \leq Q < 9$	15
$9 \leq Q < 10$	16
$10 \leq Q < 11$	17
$11 \leq Q < 12$	18
$12 \leq Q < 13$	19
$13 \leq Q < 14$	20
$14 \leq Q < 15$	21
$15 \leq Q < 16$	22
$16 \leq Q < 17$	23
$17 \leq Q < 18$	24
$18 \leq Q < 19$	25
$19 \leq Q < 20$	26
$20 \leq Q < 21$	27
$21 \leq Q < 22$	28
$22 \leq Q < 23$	29
$23 \leq Q < 24$	30
$24 \leq Q < 25$	31

If the higher layer signalling information regarding the required P-CCPCH reference powers is not available, the UE shall return an SNPL index value of 7.

4.13.3 Channelisation code hopping procedure for E-PUCH

Channelisation code hopping may be applied to E-PUCH transmissions.

When channelisation code hopping is configured by higher layers, the allocated OVFSF code (determined by the code resource related information (CRR) on E-AGCH – see [9]) is first transformed by the physical layer into a sequence of “effective” allocated OVFSF codes (one for each active timeslot of the resource allocation) before further physical layer processing is performed (see figure 5a). The mapping of the allocated code to the sequence of effective codes is a function of the allocated timeslots and of the current CFN.

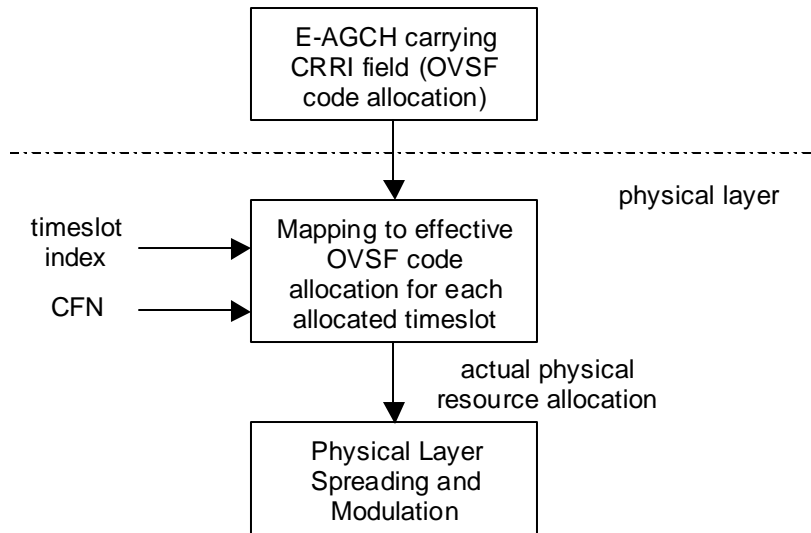

Figure 5a - physical layer interpretation of OVSF code allocation in the case that channelisation code hopping is applied

The allocated OVSF code (indicated by E-AGCH) is denoted C^{alloc} . The sequence of “effective” allocated OVSF codes is denoted $C_{t_i}^{eff}$, one for each allocated timeslot index value t_i . n_{TRRI} is configured by higher layers [15].

The set of n_{TRRI} timeslots configured for E-DCH use is denoted t_{E-DCH} (where each element of t_{E-DCH} may assume a value between 0 and 14). The first element of t_{E-DCH} is associated with $t_i = 0$, the second element with $t_i = 1$ and so on. $t_i = 0$ therefore corresponds to the lowest numbered timeslot configured for E-DCH use and to the first element (LSB) of the timeslot resource related information bit map [9].

A hopping index parameter h_i is calculated for each timeslot of the E-DCH TTI in which the UE has been allocated as follows:

$$h_i = (t_i + CFN) \text{ mod } 16$$

The effective allocated OVSF code $C_{t_i}^{eff}$ for timeslot index t_i is then derived from h_i and the channelisation code indicated by the corresponding E-AGCH (C^{alloc}) as according to table 1c.

Table 1c: Hopping index parameter sequences

C^{alloc}	CRRi	Hop index h_i															
		0	1	2	3	4	5	6	7	8	9	10	11	12	13	14	15
SF16																	
1	15	1	9	5	13	3	11	7	15	2	10	6	14	4	12	8	16
2	16	2	10	6	14	4	12	8	16	1	9	5	13	3	11	7	15
3	17	3	11	7	15	1	9	5	13	4	12	8	16	2	10	6	14
4	18	4	12	8	16	2	10	6	14	3	11	7	15	1	9	5	13
5	19	5	13	1	9	7	15	3	11	6	14	2	10	8	16	4	12
6	20	6	14	2	10	8	16	4	12	5	13	1	9	7	15	3	11
7	21	7	15	3	11	5	13	1	9	8	16	4	12	6	14	2	10
8	22	8	16	4	12	6	14	2	10	7	15	3	11	5	13	1	9
9	23	9	1	13	5	11	3	15	7	10	2	14	6	12	4	16	8
10	24	10	2	14	6	12	4	16	8	9	1	13	5	11	3	15	7
11	25	11	3	15	7	9	1	13	5	12	4	16	8	10	2	14	6
12	26	12	4	16	8	10	2	14	6	11	3	15	7	9	1	13	5

13	27	13	5	9	1	15	7	11	3	14	6	10	2	16	8	12	4
14	28	14	6	10	2	16	8	12	4	13	5	9	1	15	7	11	3
15	29	15	7	11	3	13	5	9	1	16	8	12	4	14	6	10	2
16	30	16	8	12	4	14	6	10	2	15	7	11	3	13	5	9	1

SF8

1	7	1	5	3	7	2	6	4	8	1	5	3	7	2	6	4	8
2	8	2	6	4	8	1	5	3	7	2	6	4	8	1	5	3	7
3	9	3	7	1	5	4	8	2	6	3	7	1	5	4	8	2	6
4	10	4	8	2	6	3	7	1	5	4	8	2	6	3	7	1	5
5	11	5	1	7	3	6	2	8	4	5	1	7	3	6	2	8	4
6	12	6	2	8	4	5	1	7	3	6	2	8	4	5	1	7	3
7	13	7	3	5	1	8	4	6	2	7	3	5	1	8	4	6	2
8	14	8	4	6	2	7	3	5	1	8	4	6	2	7	3	5	1

SF4

1	3	1	3	2	4	1	3	2	4	1	3	2	4	1	3	2	4
2	4	2	4	1	3	2	4	1	3	2	4	1	3	2	4	1	3
3	5	3	1	4	2	3	1	4	2	3	1	4	2	3	1	4	2
4	6	4	2	3	1	4	2	3	1	4	2	3	1	4	2	3	1

SF2

1	1	1	2	1	2	1	2	1	2	1	2	1	2	1	2	1	2
2	2	2	1	2	1	2	1	2	1	2	1	2	1	2	1	2	1

SF1

1	0	1	1	1	1	1	1	1	1	1	1	1	1	1	1	1	1
---	---	---	---	---	---	---	---	---	---	---	---	---	---	---	---	---	---

For all subsequent operations, the physical layer shall assume the allocated E-PUCH physical resources to be described by the effective allocated code $C_{t_i}^{eff}$ derived for that timeslot.

4.14 Physical Layer Procedures for 3.84 Mcps MBSFN IMB

4.14.1 Radio frame timing on the MBSFN layer

MBSFN cluster search and radio frame synchronisation on the MBSFN layer can be performed via SCH, e.g. by following the steps described in Annex C of [6]. After the primary scrambling code has been identified, the P-CCPCH can be detected and MBSFN system information can be read.

4.14.2 Downlink Power Control

The transmit powers of all downlink physical channels is determined by the network.

4.14.2.1 S-CCPCH

The TFCI field shall be transmitted at the same constellation power as the data field of the associated physical channel.

For MBSFN FACH transmission with 16QAM, the UE is informed about the relative transmit power of the S-CCPCH (measured as the power of the transmitted data of S-CCPCH) compared to the primary CPICH transmit power by the higher layers.

4.14.2.2 MICH

The UE is informed about the relative transmit power of the MICH (measured as the power over the notification indicators) compared to the primary CPICH transmit power by the higher layers.

4.14.2.3 P-CPICH

The UE may assume that the P-CPICH is transmitted with constant power.

4.14.2.4 T-CPICH

The UE may assume that each constituent OVSF code of the T-CPICH is transmitted with equal power. The UE may also assume the ratio of power allocated to the T-CPICH and P-CPICH is constant.

5 Physical layer procedures for the 1.28 Mcps option

5.1 Transmitter Power Control

The basic purpose of power control is to limit the interference level within the system thus reducing the intercell interference level and to reduce the power consumption in the UE.

The main characteristics of power control are summarized in the following table.

Table 2: Transmit Power Control characteristics

	Uplink	Downlink
Power control rate	Variable Closed loop: 0-200 cycles/sec. Open loop: (about 200us – 3575us delay)	Variable Closed loop: 0-200 cycles/sec.
Step size	1,2,3 dB (closed loop)	1,2,3 dB (closed loop)
Remarks	All figures are without processing and measurement times	

Note: All codes within one timeslot allocated to the same CCTrCH use the same transmission power in case they have the same Spreading Factor.

5.1.1 Uplink Control

5.1.1.1 General limits

By means of higher layer signalling, the `Maximum_Allowed_UL_TX_power` for uplink may be set to a value lower than what the terminal power class is capable of. Uplink power control shall be performed while the total UE transmit power is below the maximum allowed output TX power. In some cases the total requested UE transmit power in a timeslot after uplink power control calculation might exceed the maximum allowed output power. In these cases the calculated transmit power of all uplink physical channels in this timeslot shall be scaled by the same amount in dB before transmission in order that the total UE transmission power used shall be the maximum allowed output power.

The UTRAN may not expect the UE to be capable of reducing its total transmit power below the minimum level specified in [2].

5.1.1.2 UpPCH

The transmit power for the UpPCH is set by higher layers based on open loop power control as described in [15]

5.1.1.3 PRACH

The transmit power for the PRACH is set by higher layers based on open loop power control as described in [15].

5.1.1.4 DPCH and PUSCH

The initial transmission power for uplink DPCH and PUSCH is set by higher layers based on open loop power control as described in [15]. The UE then transits into closed loop power control. The node B shall generate TPC commands according to a quality target set by higher layers in order to instruct an increase or decrease in the level of transmission power from the UE and send them either in the TPC field of associated downlink CCTrCHs (see [8] for a description of the mapping between DL associated TPC symbols and UL controlled CCTrCH/timeslots) or on PLCCH (see [8] 5A.3.13). If the physical channel power should be increased, the TPC command is set to “up”, whereas if the power should be reduced the command is set to “down”. A TPC command sent in a downlink CCTrCH or via PLCCH controls all uplink DPCHs and PUSCHs in the associated uplink CCTrCH and timeslot. An example of SIR based UL power control is given in annex A 2

If signalled by higher layers, the UE must follow the received TPC commands only. In this case, at the UE when the TPC command is judged as ‘down’, the mobile transmit power shall be reduced by one power control step, whereas if it is judged as ‘up’, the mobile transmit power shall be raised by one power control step.

If indicated as allowed by higher layers, the UE may optionally take into account pathloss estimated from beacon function physical channels in addition to the TPC commands when calculating the transmit power. In this case, the mobile transmit power is first modified as described above by the received TPC command and is then further modified based upon the pathloss estimated on recent beacon transmissions. Modifications based upon pathloss shall only be applied when the UE estimates that the pathloss on the uplink transmission timeslot and the pathloss on the beacon timeslots used to derive the modification value are likely to be similar.

The closed loop power control procedure for UL DPCH and PUSCH is not affected by the use of TSTD.

In the event of no associated uplink data being transmitted between two related downlink TPC commands, the UE shall ignore the resulting TPC command. The transmit power for the next instance of the timeslot/CCTrCH pair shall then be set:

- i) to the power level of the previous uplink transmission, optionally modified to compensate for the change in pathloss observed during the uplink transmission pause or,
- ii) using the open loop procedure as for initial transmissions.

The UE shall select which of the above methods to apply. For short transmission pauses method (i) should be used.

5.1.1.4.1 Gain Factors

Same as that of 3.84 Mcps TDD, cf. [4.2.2.3.1 Gain Factors].

5.1.1.4.2 Out of synchronization handling

In the case that uplink DPCH is controlled by TPC commands carried on downlink DPCH, out of synchronisation handling is the same as that of 3.84 Mcps TDD, cf. [4.2.2.3.2 Out of synchronisation handling].

In the case that uplink DPCH is controlled by TPC commands carried on PLCCH, the UE shall shut off the transmission of an UL CCTrCH if the following criteria are fulfilled for the PLCCH carrying its TPC commands:

- The UE estimates the received PLCCH quality over the last 160 ms period to be worse than a threshold Q_{out} . Q_{out} is defined implicitly by the relevant tests in [2].

The UE shall subsequently resume the uplink transmission of the CCTrCH if the following criteria are fulfilled:

- The UE estimates the received PLCCH reception quality over the last 160 ms period to be better than a threshold Q_{in} . Q_{in} is defined implicitly by the relevant tests in [2].

5.1.1.5 HS-SICH

If the UE is not configured in MIMO mode, the transmit power of the HS-SICH shall be set by the UE according to the procedures described below. In the case that an ACK is being transmitted on the HS-SICH, the UE shall apply a power offset to the transmit power of the entire HS-SICH. This power offset shall be signalled by higher layers.

For the transmissions on the semi-persistent HS-PDSCH resources without an HS-SCCH, the TPC command for HS-SICH can be conveyed in HS-PDSCH.

On receipt of a TPC command in the HS-SCCH or HS-PDSCH, the UE shall adjust the HS-SICH transmit power according to the power control step size specified by higher layers. The UE shall ignore the TPC command transmitted on an HS-SCCH order which is an uplink synchronization establishment command. An example of SIR based UL power control is given in annex A5.

- i. However, for the first HS-SICH transmission following the first detected HS-SCCH transmission, the UE shall use open loop power control to set the HS-SICH transmit power for that transmission. In this case, the transmission power for HS-SICH is set by higher layers based on open loop power control as described in [15].
- ii. When the transmission interval of HS-SICHs, which are in the same time slot, is less than a certain threshold, which is signalled by higher layers, UE shall adjust the transmit power according to received TPC command in HS-SCCH or HS-PDSCH during HS-SICH transmission pause based on transmission power of last instance. When receipt of TPC commands in HS-PDSCH and in HS-SCCH is in the same sub-frame, UE shall treat one single TPC command if they are identical and discard them if they are different. If indicated by higher layers, UE should take into account the pathloss compensation by means of beacon channel estimation in addition to the TPC command when calculating HS-SICH transmit power.
- iii. When the transmission interval of HS-SICHs, which are in the same time slot, is equal or larger than a certain threshold, for the next instance of HS-SICH, UE shall use open loop power control described above for the initial transmission.

If the UE is configured in MIMO mode, the transmit power of the HS-SICH shall be set by the UE according to the procedures described below.

The procedure for MIMO single stream transmission is the same as that the UE is not configured in MIMO mode.

For MIMO dual stream transmission, in the case that two ACKs are being transmitted on the HS-SICH, the UE shall apply a power offset to the transmit power of the entire HS-SICH. This power offset shall be signalled by higher layers.

On receipt of a TPC command in the HS-SCCH or HS-PDSCH, the UE shall adjust the HS-SICH transmit power according to the power control step size specified by higher layers. An example of SIR based UL power control is given in annex A5.

- i. However, for the first HS-SICH transmission following the first detected HS-SCCH transmission, the UE shall use open loop power control to set the HS-SICH transmit power for that transmission. In the case of dual stream transmission, a delta is applied to the HS-SICH transmission power. The delta implies the required power offset of the HS-SICH transmission for the different number of the data streams under the limit of SIR target. This transmission power is set by higher layers based on open loop power control as described in [15].
- ii. When the transmission interval of HS-SICHs, which are in the same time slot, is less than a certain threshold, which is signalled by higher layers, UE shall adjust the transmit power according to received TPC command during HS-SICH transmission pause based on transmission power of last instance. In the case of dual stream transmission, a delta is applied to the HS-SICH transmission power. If indicated by higher layers, UE should take into account the pathloss compensation by means of beacon channel estimation in addition to the TPC command when calculating HS-SICH transmit power.
- iii. When the transmission interval of HS-SICHs, which are in the same time slot, is equal or larger than a certain threshold, for the next instance of HS-SICH, UE shall use open loop power control described above for the initial transmission.

5.1.1.6 E-PUCH

For multi-carrier E-DCH transmission, the open-loop and closed-loop power control of E-PUCH on each carrier is independent from each other. The power of E-PUCH on each carrier is set as follows.

The power of E-PUCH is set following the same principle used for DPCH/PUSCH in R4/5/6 [15] and in 5.1.1.4, i.e., the combination of open-loop power control and traditional closed-loop power control:

- the initial transmit power of E-PUCH is set based on an open-loop power control scheme, then
- the transmission power control transits into closed-loop power control using TPC commands carried on E-AGCH or on E-HICH on the same carrier. For non-scheduled transmission, the TPC commands are carried on E-HICH only. Both TPC commands carried on E-AGCH and E-HICH are used on E-PUCH

The transmit power for E-PUCH set in the UE is calculated as follows:

$$P_{E-PUCH} = P_{e-base} + L + \beta_e$$

... where:

- P_{E-PUCH} is the transmit power of the E-DCH physical channel E-PUCH.
- P_{e-base} is a closed-loop quantity maintained by the UE and NodeB for each carrier, and which is incremented or decremented by a value Δ_{e-base} upon each receipt of a TPC command on E-AGCH for scheduled transmission or on E-HICH for non-scheduled transmission on the same carrier. On receipt of a TPC “up” command, P_{e-base} is incremented by Δ_{e-base} . On receipt of a TPC “down” command, P_{e-base} is decremented by Δ_{e-base} . The TPC step size Δ_{e-base} is configured by higher layers [15].

$$P_{e-base} = PRX_{des_base} + step * \sum_i TPC_i = PRX_{des_base} + P_{TPC}$$

...where, PRX_{des_base} is the *reference Desired E-PUCH RX power* signalled by RRC signalling for each carrier according to [15], which is set to the average value of the interference signal power level over the timeslots configured for E-DCH use.

$step$ is the power control step size Δ_{e-base} configured by higher layers, and TPC_i is a closed-loop control command.

- L is a pathloss term derived from beacon function physical channels. The same as that in 5.1.1.4, if indicated as allowed by higher layers, the UE may optionally take into account pathloss modification which is estimated from the most recently received beacon function physical channel transmission, in addition to the TPC commands when calculating the transmit power.
- β_e is the gain factor for the selected E-TFC transport block size, the allocated E-PUCH physical resources, and the Modulation type and HARQ power offset according to subclause 5.1.1.6.1. If the smallest E-TFC is selected, β_e equals to the sum of absolute grant value and α_e .

Higher layers in the UE shall use the current calculated E-PUCH power in conjunction with the current absolute grant (power) value in order to determine the set of E-TFC's available.

UE maintains a closed-loop quantity P_{e-base} for both scheduled transmission and non-scheduled transmission.

P_{e-base} is incremented or decremented by a value Δ_{e-base} upon each receipt of a TPC command on E-AGCH and on E-HICH on the same carrier. When receipt of TPC commands on E-AGCH and on E-HICH is in the same sub-frame, UE shall treat one single TPC command if they are identical and discard them if they are different.

When following an extended pause, which is signalled by higher layers, in the reception of TPC commands on E-AGCH and on E-HICH, the UE shall set P_{e-base} equal to the *reference Desired E-PUCH RX power*. When receipt of

TPC commands on E-AGCH or on E-HICH recommences, the TPC commands shall be used to modify P_{e-base} from its previously set value.

5.1.1.6.1 Gain Factors for E-PUCH

A beta factor shall be derived by the UE as a function of:

- the selected E-TFC transport block size
- the E-PUCH resource occupation in the E-DCH TTI
- the modulation type (QPSK/16-QAM)
- the HARQ power offset

Higher layers shall provide a mapping table containing a set of reference points, which defines the relationship between the coderate of E-DCH transmission (λ_e) and the relative reference power per resource unit (β_λ dB). The mapping table is provided separately for each of QPSK and 16-QAM modulation.

The coderate of E-DCH transmission λ_e for the selected E-TFC, physical resource allocation and modulation type is defined as:

$$\lambda_e = \frac{S_e}{R_e}$$

... in which S_e is the transport block size of the selected E-TFC and R_e is the number of physical channel bits output from the physical channel mapping stage of E-DCH transport channel processing as described in [9]. The precision requirement for λ_e is 1×10^{-4} and the quantization mode is truncation.

The maximum and minimum values of λ are the maximum and minimum values of Reference Code Rate respectively, which are signalled by higher layers for the appropriate modulation type [15], and are denoted λ_{max} and λ_{min} respectively. For a given λ_e there exist a λ_0 and a λ_1 such that:

- If $\lambda_{min} \leq \lambda_e < \lambda_{max}$
 - λ_0 is the largest λ signalled by higher layers for the appropriate modulation type and for which $\lambda \leq \lambda_e$
 - λ_1 is the smallest λ signalled by higher layers for the appropriate modulation type and for which $\lambda > \lambda_e$
- Else
 - If $\lambda_e < \lambda_{min}$ then $\lambda_0 = \lambda_{min}$ and λ_1 is the smallest signalled λ for which $\lambda > \lambda_{min}$.
 - If $\lambda_e \geq \lambda_{max}$ then λ_0 is the largest signalled λ for which $\lambda < \lambda_{max}$ and $\lambda_1 = \lambda_{max}$

Associated with λ_0 and λ_1 are the corresponding β_{λ_0} and β_{λ_1} which define the reference points signalled by higher layers. The normalised (per-resource-unit) beta value for the selected E-TFC and E-PUCH resource set is denoted $\beta_{0,e}$ and is:

$$\beta_{0,e} = \beta_{\lambda_0} + \frac{\beta_{\lambda_1} - \beta_{\lambda_0}}{\lambda_1 - \lambda_0} (\lambda_e - \lambda_0) \text{ dB}$$

The precision requirement for $\beta_{0,e}$ is 1×10^{-3} and the quantization mode is truncation.

α_e is a logarithmic value set as a function of the E-PUCH spreading factor (SF_{E-PUCH}) according to table 2a.

Table 2a: Tabulated α_e values

SF_{E-PUCH}	α_e (dB)
---------------	-----------------

1	12
2	9
4	6
8	3
16	0

β_e is then derived as
$$\beta_e = \beta_{0,e} + \alpha_e + \Delta_{harq} \text{ dB}$$

Δ_{harq} is set by higher layers (see [18]).

5.1.1.7 E-RUCCH

The transmit power for the E-RUCCH is set following the same formula used for PRACH based on open loop power control as described in [15].

5.1.1.8 Standalone midamble channel

If the UE is configured in MIMO mode, the transmit power for the standalone midamble channel shall be the same as that used for the associated HS-SICH in the same subframe.

If the UE is configured in MU-MIMO mode, the transmit power for the standalone midamble channel shall make reference to the last transmitted HS-SICH or E-PUCH. When the last transmitted uplink channel is HS-SICH, the transmit power of the standalone midamble channel shall be the same as the last transmitted HS-SICH. When the last transmitted uplink channel is E-PUCH, the transmit power of the standalone midamble channel shall be calculated as follows:

$$P_{S \text{ standalone}} = P_{e\text{-base}} + L + \beta_S$$

... where:

- $P_{e\text{-base}}$ is the desired receiving power of E-PUCH.
- β_S is the gain factor for standalone midamble channel, and should be configured by high layer.
- L is a pathloss term derived from beacon function physical channels.

5.1.2 Downlink Control

The total downlink transmission power at the Node B within one timeslot shall not exceed the Maximum Transmission Power set by higher layer signalling.

5.1.2.1 P-CCPCH

Same as that of 3.84 Mcps TDD, cf.[4.2.3.1 P-CCPCH].

5.1.2.2 The power of the FPACH

The transmit power for the FPACH is set by the higher layer signalling [16].

5.1.2.3 S-CCPCH, PICH

Same as that of 3.84 Mcps TDD, cf.[4.2.3.2 S-CCPCH, PICH].

5.1.2.3A MICH

Same as that of 3.84 Mcps TDD, cf.[4.2.3.2A MICH].

5.1.2.4 DPCH, PDSCH

The initial transmission power of the downlink Dedicated Physical Channel is signalled by higher layers. After the initial transmission, the node B transits into closed-loop TPC. The UE shall generate TPC commands according to a quality target set by higher layers in order to control the level of transmission power from the node B and send them in the TPC field of associated uplink CCTrCHs (see [8] for a description of the mapping between UL associated TPC symbols and DL controlled CCTrCH/timeslots) or in the Non-scheduled E-PUCH when the associated uplink CCTrCHs do not exist. If the physical channel power should be increased, the TPC command is set to “up”, whereas if the power should be reduced the command is set to “down”. A TPC command sent in an uplink CCTrCH or in the Non-scheduled E-PUCH when the associated uplink CCTrCH does not exist controls all downlink DPCHs or PDSCHs in the associated downlink CCTrCH and timeslot.

UTRAN may decide how to adjust the transmit power in response to the received TPC command

When TSTD is applied, the UE can use two consecutive measurements of the received SIR in two consecutive sub-frames to generate the power control command. An example implementation of DL power control procedure for 1.28 Mcps TDD when TSTD is applied is given in Annex A.3.

The transmission power of one DPCH or PDSCH shall not exceed the limits set by higher layer signalling by means of Maximum_DL_Power (dB) and Minimum_DL_Power (dB). The transmission power is defined as the average power over one timeslot of the complex QPSK (or 8PSK respectively) symbols of a single DPCH or PDSCH before spreading relative to the power of the P-CCPCH.

Each TPC command shall be based on all associated downlink transmissions since the previous related TPC command.

In the event of no associated downlink data being transmitted between two related TPC commands, the UTRAN should ignore the resulting TPC command.

5.1.2.4.1 Out of synchronisation handling

Same as that of 3.84 Mcps TDD, cf.[4.2.3.4.1 Out of synchronisation handling].

5.1.2.5 HS-PDSCH

The power control for HS-PDSCH for 1.28 Mcps TDD is the same as for 3.84 Mcps, see section 4.2.3.5

5.1.2.6 HS-SCCH

Higher layers shall indicate the maximum transmit power of the HS-SCCH. The Node-B shall not exceed this maximum power when setting the HS-SCCH power.

The initial power of the HS-SCCH is at the discretion of the Node-B. Following the initial transmission, the NodeB may optionally power control the HS-SCCH. This may be done using TPC commands sent by the UE in the HS-SICH. When the transmission interval of HS-SCCHs, which are in the same time slot, is more than or equal to a certain threshold, which is signalled by higher layers, NodeB shall use initial transmit power for the next HS-SCCH transmission.

The UE shall set the TPC commands in the HS-SICH in order to control the transmit power of the HS-SCCH. The TPC commands shall be set in order to meet the HS-SCCH target BLER.

The accuracy of the received HS-SCCH BLER estimate made by the UE may be enhanced by a suitable use of the HCSN field received within the HS-SCCH itself [9]. This field shall initially be set to zero and shall be incremented by the NodeB each time an HS-SCCH is transmitted to the UE. UE without a dedicated UE identity in CELL_FACH state and UE in CELL_PCH state shall ignore the value of HCSN.

5.1.2.7 PLCCH

The initial transmission power of the downlink PLCCH is signalled by higher layers. After the initial transmission, the transmission power of PLCCH is under the control of Node-B. The Node-B may optionally adjust the transmission power of PLCCH according to the received TPC commands which are carried by the PLCCH-controlled UL CCTrCH(s). The UE shall generate TPC commands according to a PLCCH quality target set by higher layers. If the PLCCH power should be increased, the TPC command is set to “up”, whereas if the power should be reduced the command is set to “down”. UTRAN may decide how to adjust the transmit power in response to the received TPC commands. The average power of transmitted PLCCH symbols over one timeslot shall not exceed the limits set by higher layers. The transmission power is defined as the average power over one timeslot of the complex QPSK symbols of a single PLCCH before spreading relative to the power of the P-CCPCH.

5.1.2.8 E-AGCH

For multi-carrier E-DCH transmission, the power control of E-AGCH on each carrier is independent from each other and described as follows.

Higher layers shall indicate the maximum transmit power of the E-AGCH. The Node-B shall not exceed this maximum power when setting the E-AGCH power.

The initial power of the E-AGCH is at the discretion of the Node-B. Following the initial transmission, the Node-B may optionally power control the E-AGCH. This may be done using TPC commands sent by the UE in the scheduled E-PUCH on the same carrier.

The UE shall set the TPC commands in the Scheduled E-PUCH on the same carrier in order to control the transmit power of the E-AGCH. The TPC commands shall be set in order to meet the E-AGCH target BLER.

The accuracy of the received E-AGCH BLER estimate made by the UE shall be enhanced by a suitable use of the ECSN field received within the E-AGCH itself [9]. This field shall initially be set to zero and shall be incremented by the Node-B each time an E-AGCH is transmitted to the UE. For each carrier in multi-carrier E-DCH transmission, the ECSN shall initially be set to zero and shall be incremented by the Node-B each time an E-AGCH is transmitted on the carrier to the UE.

5.1.2.9 E-HICH

The power of the E-HICH is under the control of the Node B.

5.2 UL Synchronisation

5.2.1 General Description

Support of UL synchronization is mandatory for the UE.

5.2.1.1 Preparation of uplink synchronization (downlink synchronization)

When a UE is powered on, it first needs to establish the downlink synchronisation with the cell. Only after the UE has established the downlink synchronisation, it shall start the uplink synchronisation procedure.

5.2.1.2 Establishment of uplink synchronization

The establishment of uplink synchronization is done during the random access procedure and involves the UpPCH and the PRACH or the E-RUCCH.

Although the UE can receive the downlink signal from the Node B, the distance to Node B is still uncertain. This would lead to unsynchronised uplink transmission. Therefore, the first transmission in the uplink direction is performed in a special time-slot UpPTS or other uplink access position indicated by UTRAN to reduce interference in the traffic time-slots.

After the detection of the SYNC-UL sequence in the searching window, the Node B will evaluate the timing, and reply by sending the adjustment information to the UE to modify its timing for next transmission. This is done with the

FPACH within the following 4 sub-frames. After sending the PRACH or the E-RUCCH, the uplink synchronization is established. The uplink synchronisation procedure shall also be used for the re-establishment of the uplink synchronisation when uplink is out of synchronisation.

5.2.1.3 Maintenance of uplink synchronisation

Uplink synchronization is maintained in 1.28 Mcps TDD by sending the uplink advanced in time with respect to the timing of the received downlink.

For the maintenance of the uplink synchronization, the midamble field of each uplink burst can be used.

In each uplink time slot the midamble for each UE is different. The Node B may estimate the timing by evaluating the channel impulse response of each UE in the same time slot. Then, in the next available downlink time slot, the Node B will signal Synchronisation Shift (SS) commands to enable the UE to properly adjust its Tx timing.

5.2.2 UpPCH

Open loop uplink synchronisation control is used for UpPCH.

The UE may estimate the propagation delay Δt_p based upon the path loss using the received P-CCPCH and/or DwPCH power.

The UpPCH is sent to the Node B advanced in time according to the timing of the received DwPCH. The time of the beginning of the UpPCH $T_{TX-UPPCH}$ is given by:

$$T_{TX-UPPCH} = T_{RX-DWPCH} - 2\Delta t_p + 12 \cdot 16 T_C + n_{UPPCHShift} \cdot 16 T_C$$

$n_{UPPCHShift} = 0..127$, $n_{UPPCHShift}$ is indicated by higher layers

in multiple of 1/8 chips, where

$T_{TX-UPPCH}$ is the beginning time of UpPCH transmission with the UE's timing,

$T_{RX-DWPCH}$ is the received beginning time of DwPCH with the UE's timing,

$2\Delta t_p$ is the timing advance of the UpPCH default value is $48T_C$.

5.2.3 PRACH

The Node B shall measure the received SYNC-UL timing deviation $UpPCH_{POS}$. $UpPCH_{POS}$ is sent in the FPACH and is represented as a 13 bit number (0-8191) being the multiple of 1/8 chips which is nearest to received position of the UpPCH.

Time of the beginning of the PRACH $T_{TX-PRACH}$ is given by:

$$T_{TX-PRACH} = T_{RX-PRACH} - (UpPCH_{ADV} + UpPCH_{POS} - 8 \cdot 16 T_C)$$

in multiple of 1/8 chips, where

$T_{TX-PRACH}$ is the beginning time of PRACH transmission with the UE's timing,

$T_{RX-PRACH}$ is the beginning time of PRACH reception with the UE's timing if the PRACH was a DL channel.

5.2.4 DPCH and PUSCH

The closed loop uplink synchronisation control uses layer 1 symbols (SS commands) for DPCH and PUSCH. After establishment of the uplink synchronisation, NodeB and UE start to use the closed loop UL synchronisation control procedure. This procedure is continuous during connected mode.

The Node B will continuously measure the timing of the UE and send the necessary synchronisation shift commands in each sub-frame. The UE shall derive a single SS command separately for each controlled uplink timeslot by combining all received SS commands that are related to the controlled time slot (cf. [8]) and that are received within the last up to M sub-frames. The value of the "Uplink synchronisation frequency" M (1..8) is configured by higher layers.

When the combined SS command is judged as ‘down’, the UE transmit timing for the controlled UL timeslot shall be delayed by one timing adjustment step of $k/8$ chips. When the command is judged as ‘up’, the UE transmit timing for the controlled UL timeslot shall be advanced by one timing adjustment step of $k/8$ chips. When the command is judged as ‘do nothing’, the timing shall not be changed. The value of the “Uplink synchronisation step size” k (1.8) is configured by higher layers.

The timing adjustment shall take place in each sub-frame satisfying the following equation:

$$SFN' \bmod M = 0$$

where

SFN' is the system frame number counting the sub-frames. The system frame number of the radio frames (SFN) can be derived from SFN' by

$SFN = SFN' \text{ div } 2$, where div is the remainder free division operation.

During a 1.28 Mcps TDD to 1.28 Mcps TDD hand-over the UE shall transmit in the new cell with timing advance TA adjusted by the relative timing difference Δt between the new and the old cell if indicated by higher layers:

$$TA_{\text{new}} = TA_{\text{old}} + 2\Delta t.$$

5.2.4.1 Out of synchronization handling

Same as that of 3,84 Mcps TDD, cf. [4.2.2.3.2 Out of synchronisation handling.]

5.2.5 HS-SICH

If there is associated uplink DPCH or non-scheduled E-PUCH, the initial transmit timing for the HS-SICH shall be taken from that of the associated uplink DPCH or non-scheduled E-PUCH. Otherwise, the initial transmit timing for the HS-SICH shall be taken from that of the last uplink transmission except UpPCH transmission. The UE shall then adjust the timing of the HS-SICH according to SS commands transmitted to it on the HS-SCCH or HS-PDSCH. The step size for these commands shall be signalled to the UE by higher layers. The UE shall ignore the SS command transmitted on an HS-SCCH order which is an uplink synchronization establishment command. In the case that there is a gap of one or more subframes during which no SS commands are received by the UE, the UE shall adjust the timing of the HS-SICH according to the associated uplink DPCH or non-scheduled E-PUCH or other uplink channel except UpPCH until such time as another HS-SCCH transmission or HS-PDSCH with SS command is received.

5.2.6 E-PUCH

Uplink synchronization control procedure for E-PUCH remains the same as that used for DPCH, cf. 5.2.4 DPCH and PUSCH, using SS commands carried on E-AGCH or on E-HICH. When receipt of SS commands on E-AGCH and on E-HICH is in the same sub-frame, UE shall treat one single SS command if they are identical and discard them if they are different.

If configured with DPCH, the timing of E-PUCH can be directly set to the timing of the DPCH. If configured with non-scheduled transmission, the timing of scheduled E-PUCH can be set to the timing of the non-scheduled E-PUCH. If neither DPCH nor non-scheduled transmission is configured, the timing of E-PUCH can be set to the timing of other uplink channels except UpPCH.

For multi-carrier E-DCH transmission, in one TTI, the timing advance of the E-PUCHs of all carriers of one UE is the same. The UE shall combine all the SS commands on each E-AGCH and E-HICH in the same TTI into one UL timing advance value.

5.2.7 E-RUCCH

The Node B shall measure the received SYNC-UL timing deviation $UpPCH_{POS}$. $UpPCH_{POS}$ is sent in the FPACH and is represented as an 13 bit number (0-8191) being the multiple of $1/8$ chips which is nearest to received position of the UpPCH.

Time of the beginning of the E-RUCCH $T_{\text{TX-E-RUCCH}}$ is given by:

$$T_{\text{TX-E-RUCCH}} = T_{\text{RX-E-RUCCH}} - (\text{UpPCH}_{\text{ADV}} + \text{UpPCH}_{\text{POS}} - 8 \cdot 16 T_C)$$

in multiple of 1/8 chips, where

$T_{\text{TX-E-RUCCH}}$ is the beginning time of E-RUCCH transmission with the UE's timing,

$T_{\text{RX-E-RUCCH}}$ is the beginning time of E-RUCCH reception with the UE's timing if the E-RUCCH was a DL channel,

$\text{UpPCH}_{\text{ADV}}$ is the timing advance of the UpPCH.

5.2.8 Standalone midamble channel

The transmit timing for the standalone midamble channel shall be taken from that of the last uplink transmission.

5.3 Synchronisation procedures

5.3.1 Cell search

During the initial cell search, the UE searches for a cell. It then determines the DwPTS synchronisation, scrambling code and basic midamble code, control multi-frame synchronisation and then reads the BCH. How cell search is typically done is described in Annex CA.

For MBSFN FACH, the downlink scrambling codes and basic midamble codes to be used for non-beacon timeslots are signalled by higher layers.

5.3.2 DCH synchronization

The DPCH synchronisation is the same as that of 3.84 Mcps TDD, cf. [4.4.2 Dedicated channel synchronisation].

5.3.2A Shared physical channel synchronization

For HS-DSCH and E-PUCH operation without DPCH, the synchronisation procedure is defined in the subclause.

5.3.2A.1 Synchronisation primitives

5.3.2A.1.1 General

For the shared physical channels, synchronisation primitives are used to indicate the synchronisation status of radio links, both in uplink and downlink. The definition of the primitives is given in the following subclauses.

5.3.2A.1.2 Downlink synchronisation primitives

The UE shall measure any of the following downlink physical channels on any carrier to estimate downlink quality.

- a) HS-PDSCH
- b) HS-SCCH
- c) E-AGCH

Layer 1 in the UE shall check the synchronization status of downlink physical channels on all carriers. Synchronisation status is indicated to higher layers, using the CPHY-Sync-IND or CPHY-Out-of-Sync-IND primitives.

The criteria for reporting synchronization status are defined in two different phases.

The first phase lasts until the downlink shared channel is considered to be established by higher layers. During this phase, out-of-sync shall not be reported. in-sync shall be reported using the CPHY-Sync-IND primitive if the following criterion is fulfilled.

- At least one downlink physical channel with a CRC attached is received in the current subframe with correct CRC.

The second phase starts after the downlink shared channel is considered established by higher layers. During this phase, both out-of-sync and in-sync are reported as follows.

Out-of-sync shall be reported using the CPHY-Out-of-Sync-IND primitive based on the synchronization status in an out-of-sync detection window if the following criterion is fulfilled. The out-of-sync detection window (out-of-sync window) is configured by higher layers.

- No downlink physical channel has been received with a correct CRC in the out-of-sync detection window period.

In the second phase, the first out-of-sync detection window starts when the second phase starts; after this, the next out-of-sync detection window starts right after the previous out-of-sync detection window.

In-sync shall be reported using the CPHY-Sync-IND primitive if the following criteria is fulfilled:

- At least one downlink physical channel with a CRC attached is received in the current subframe with correct CRC.

5.3.2A.1.3 Uplink synchronisation primitives

Layer 1 in the Node B shall check synchronisation status of uplink physical channels. Synchronisation status is indicated to the RL Failure/Restored triggering function using either the CPHY-Sync-IND or CPHY-Out-of-Sync-IND primitive. The exact criteria for indicating in-sync/out-of-sync is not subject to specification.

5.3.2A.2 Radio link monitoring

5.3.2A.2.1 Downlink radio link failure

The downlink shared physical channels are monitored by the UE, to trigger radio link failure procedures. The downlink radio link failure status is specified in [15], and is based on the synchronisation status primitives CPHY-Sync-IND and CPHY-Out-of-Sync-IND, indicating in-sync and out-of-sync respectively.

5.3.2A.2.2 Uplink radio link failure/restore

The uplink shared physical channels are monitored by the Node B in order to trigger uplink radio link failure/restore procedures. The uplink radio link failure/restore status is reported using the synchronisation status primitives CPHY-Sync-IND and CPHY-Out-of-Sync-IND, indicating in-sync and out-of-sync respectively.

When the uplink shared physical channel is in the in-sync state, Node B shall start timer T_RLFAILURE after receiving N_OUTSYNC_IND consecutive out-of-sync indications. Node B shall stop and reset timer T_RLFAILURE upon receiving successive N_INSYNC_IND in-sync indications. If T_RLFAILURE expires, Node B shall indicate to higher layers the uplink shared physical channel is out-of-sync using the synchronization status primitives. Furthermore, the uplink shared physical channel state shall be changed to the out-of-sync state.

When the uplink shared physical channel is in the out-of-sync state, after receiving N_INSYNC_IND successive in-sync indications Node B shall indicate that the uplink shared physical channel has re-established synchronisation and the uplink shared physical channel's state shall be changed to the in-sync-state. The specific parameter settings (values of T_RLFAILURE, N_OUTSYNC_IND, and N_INSYNC_IND) are configurable, see [16].

5.3.3 Synchronization procedure in CELL_FACH state

5.3.3.1 Uplink synchronization status detection

Maintaining of uplink synchronization is not needed in CELL_FACH state, UE could be out of synchronization after a period of transmission pause.

The uplink synchronization status detection is under control of Node B, which determines UE's synchronization status according to a timer T-sync. The timer is UE specific and the parameter is configured by higher layers. Node B determines the UE out of synchronization when the T-sync timer expires and in synchronization otherwise. The details of the timer T-sync operation are shown as below:

- Initially starting the timer

When Node B receives the UE's uplink E-RUCCH transmission correctly, it will initially start the timer.

- Restarting the timer

When Node B receives the UE's any uplink transmission (e.g. E-RUCCH, E-DCH or HS-SICH) correctly, it will restart the timer.

5.3.3.2 Establishment of uplink synchronization

Node B shall order UE to establish the uplink synchronization via HS-SCCH order in case that it detects the UE is out of uplink synchronization. Response to this synchronization establishment command, UE then initiates the random access procedure, cf [subclause 5.6 Random Access Procedure], which only involves the UpPCH and the E-RUCCH.

Node B will limit the synchronization delay based on a timer T-protect. If Node B doesn't receive the E-RUCCH in the synchronization procedure before T-protect expires, Node B will restart another uplink synchronization procedure via HS-SCCH order. After N-protect successive uplink synchronization attempts, Node B shall terminate the synchronization procedure and indicate an uplink synchronization failure to higher layers. The specific parameter settings (values of T-protect and N-protect) are configured by higher layers.

5.4 Discontinuous transmission (DTX) procedure

The DTX procedure shall be applied for CCTrCHs mapped to S-CCPCH, UL DPCH, DL DPCH, PUSCH and PDSCH, if the total bit rate of the CCTrCH differs from the total channel bit rate of the physical channels allocated to this CCTrCH.

Rate matching is used in order to fill resource units completely, that are only partially filled with data. In the case that after rate matching and multiplexing no data at all is to be transmitted in a resource unit the complete resource unit shall be discarded from transmission (DTX), unless a Special Burst is transmitted in the RU. This applies also to the case where only one resource unit is allocated and no data has to be transmitted.

The special burst is transmitted in both consecutive subframes (subframe# 1 and #2). SS Bits may be transmitted in Special Bursts for each CCTrCH mapped to UL DPCH, DL DPCH, PUSCH and PDSCH physical channels.

5.4.1 Description of Special Bursts

For S-CCPCH, UL DPCH, DL DPCH, PUSCH and PDSCH, the Special Burst has the same timeslot format as the burst used for data provided by higher layers. If the timeslot format contains a TFCI field, then the TFCI field shall be filled with "0" bits. The Special Burst may also carry layer 1 control symbols such as TPC bits for the purposes of inner-loop power control. The data portions of the Special Burst are filled with an arbitrary bit pattern.

For S-CCPCH, DL DPCH, PUSCH and PDSCH, the transmission power of the special burst shall be the same as that of the substituted physical channel of the CCTrCH. For UL DPCH, if the gain factor of the zero rate TFC is explicitly signalled by high layer, the transmission power of the special burst shall be weighted by the gain factor β of the zero rate TFC [refer 5.1.1.4.1], otherwise the transmission power of the special burst shall be the same as that of the substituted physical channel of the CCTrCH. In the case of uplink physical channels where autonomous spreading factor change by the UE is permitted by higher layers, the substituted physical channel is considered to be that which

would have been employed for the lowest non-zero rate TFC within the set of allowed TFC's and the transmission power of the Special Burst shall again correspond to that of the physical channel substituted.

5.4.2 Use of Special Bursts during DTX

In the case that after link establishment there are no transport blocks provided for transmission by higher layers for a given CCTrCH mapped to UL DPCH, DL DPCH, PUSCH or PDSCH physical channels, then a Special Burst shall be transmitted in the first allocated frame of the transmission pause. If, including the first frame, there is a consecutive period of Special Burst Period (SBP) frames without transport blocks provided by higher layers, then another special burst shall be generated and transmitted at the next possible frame. This pattern shall be continued until transport blocks are provided for the CCTrCH by the higher layers. SBP shall be provided by higher layers. The value of SBP shall be independently specified for uplink and for downlink and shall be designated as

SBGP (special burst generation period) for uplink transmissions

SBSP (special burst scheduling parameter) for downlink transmissions

The default value for both SBGP and SBSP shall be 8.

If DTX is applied on S-CCPCH carrying MBSFN FACH, special burst shall be sent in the first radio frame of each associated TTI.

The Special Burst shall be transmitted using the physical channel with the lowest physical channel sequence number (p) as defined by the rate matching function in [9].

5.4.3 Use of Special Bursts for Initial Establishment / Reconfiguration

Upon initial establishment or reconfiguration for either 160 ms following detection of in-sync, or until the first transport block is received from higher layers, both the UE and the Node B shall transmit the special burst for each CCTrCH mapped to UL DPCH, DL DPCH, PUSCH and PDSCH physical channels.

The Special Burst shall be transmitted using the physical channel with the lowest physical channel sequence number (p) as defined by the rate matching function in [9].

5.5 Downlink Transmit Diversity

Downlink Transmit diversity for PDSCH, DPCH, P-CCPCH, S-CCPCH, PICH, MICH, HS-SCCH, HS-PDSCH, E-AGCH, E-HICH and DwPCH is optional in UTRAN. Its support is mandatory at the UE.

5.5.1 Transmit Diversity for PDSCH, DPCH, HS-SCCH, HS-PDSCH and E-AGCH

Time Switched Transmit Diversity (TSTD) may be employed as transmit diversity scheme for downlink DPCH and PDSCH. Closed loop Transmit Diversity may be employed as transmit diversity scheme for downlink DPCH, HS-SCCH, HS-PDSCH and E-AGCH.

5.5.1.1 TSTD for PDSCH and DPCH

TSTD can be employed as transmit diversity scheme for PDSCH and downlink DPCH. An example for the transmitter structure of the TSTD transmitter is shown in figure 6. Channel coding, rate matching, interleaving, bit-to-symbol mapping, spreading, and scrambling are performed as in the non-diversity mode. Then the data is time multiplexed with the midamble sequence. Then, after pulse shaping, modulation and amplification, DPCH and/or PDSCH is transmitted from antenna 1 and antenna 2 alternately every sub-frame. Not all DPCHs and/or PDSCHs in the sub-frame need to be transmitted on the same antenna and not all DPCHs and/or PDSCHs within a sub-frame have to use TSTD. Figure 7 shows an example for the antenna switching pattern for the transmission of DPCH/PDSCH for the case that all physical channels are transmitted with TSTD and are using the same antenna in the sub-frame.

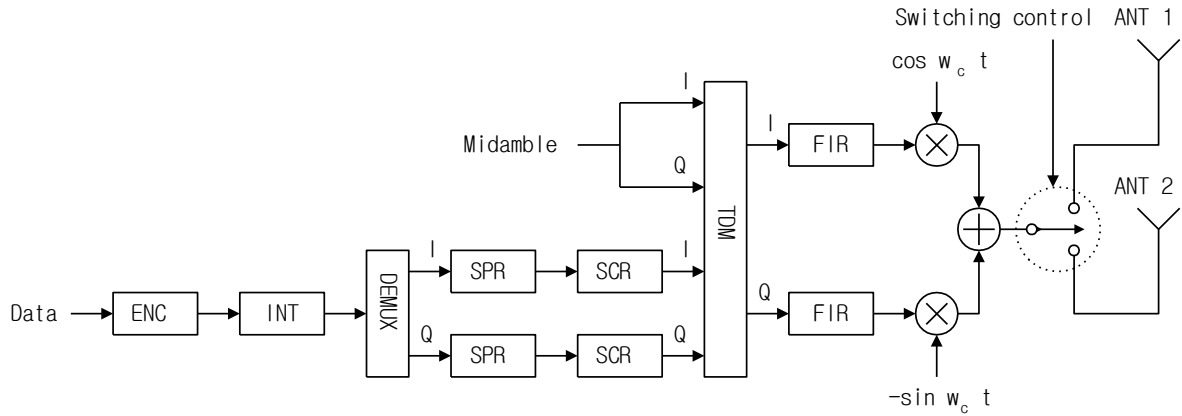

Figure 6: Example for TSTD Transmitter structure for DPCH/PDSCH and P-CCPCH.

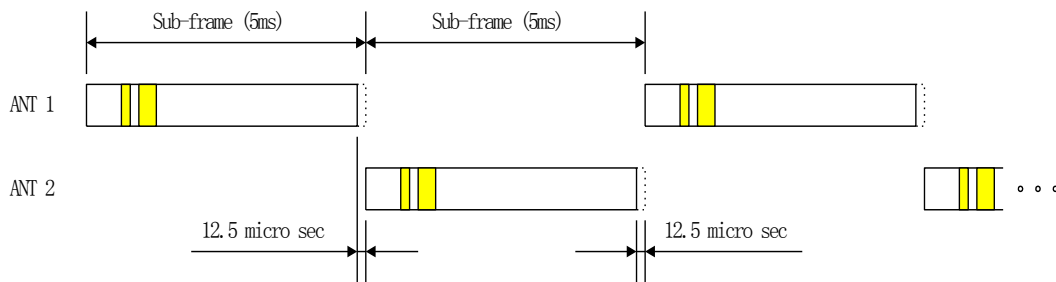

Figure 7: Example for the antenna switching pattern for TSTD transmission of DPCH/PDSCH and P-CCPCH: all physical channels are transmitted with TSTD and are using the same antenna in the sub-frame.

5.5.1.2 Closed Loop Tx Diversity for PDSCH, DPCH, HS-SCCH, HS-PDSCH and E-AGCH

The transmitter structure to support transmit diversity for DPCH, PDSCH, HS-SCCH, HS-PDSCH and E-AGCH transmission is shown in figure 8. Channel coding, interleaving and spreading are done as in non-diversity mode. The spread complex valued signal is fed to both TX antenna branches, and weighted with antenna specific weight factors w_1 and w_2 . The weight factors are complex valued signals (i.e., $w_i = a_i + jb_i$), in general. These weight factors are calculated on a per slot and per user basis.

The weight factors are determined by the UTRAN.

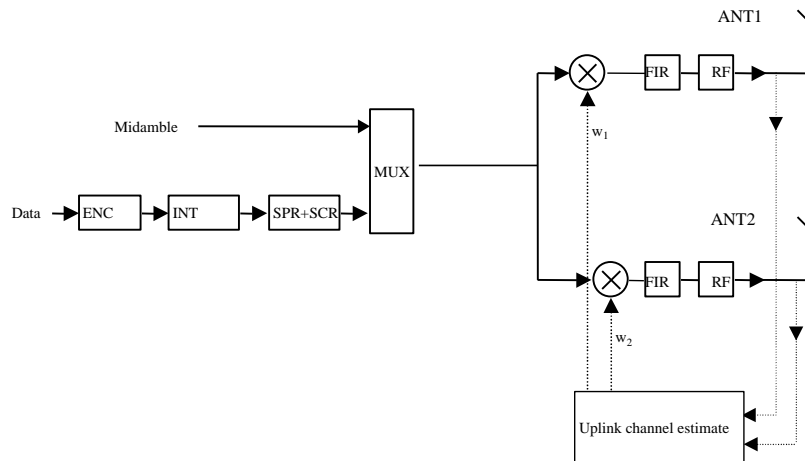

Figure 8: Downlink transmitter structure to support Transmit Diversity for DPCH, PDSCH, HS-SCCH, HS-PDSCH and E-AGCH transmission (UTRAN Access Point) in 1.28 Mcps TDD

5.5.2 Transmit Diversity for DwPCH

The transmitter structure to support transmit diversity for DwPCH transmission is shown in figure 9. DwPCH is transmitted from antenna 1 and antenna 2 alternatively.

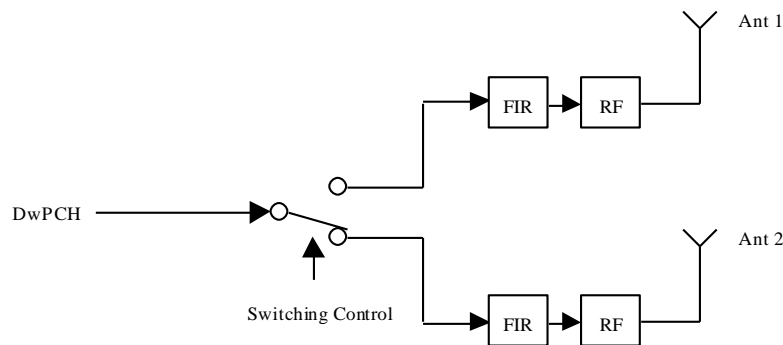

Figure 9: Downlink transmitter structure to support Transmit Diversity for DwPCH transmission (UTRAN Access Point) in 1.28 Mcps TDD

5.5.3 Transmit Diversity for P-CCPCH

TSTD or Space Code Transmit Diversity (SCTD) can be employed as transmit diversity scheme for the Primary Common Control Physical Channel (P-CCPCH)

5.5.3.1 TSTD Transmission Scheme for P-CCPCH

A block diagram of an example of a TSTD transmitter is shown in figure 6. Channel coding, rate matching, interleaving, bit-to-symbol mapping, spreading, and scrambling are performed as in the non-diversity mode. Then the data is time multiplexed with the midamble sequence. Then, after pulse shaping and modulation and amplification, P-CCPCH is transmitted from antenna 1 and antenna 2 alternately every sub-frame. If there is a DPCH that uses TSTD, TSTD is also applied to P-CCPCH. An example of the antenna-switching pattern is shown in figure 7. If TSTD is applied to P-CCPCH, it shall also be applied to other beacon channels.

5.5.4 SCTD Transmission Scheme for Beacon Channels

The use of SCTD will be indicated by higher layers. If SCTD is active within a cell, SCTD shall be applied to any beacon channel. When beacon channel is used on dedicated MBSFN frequency, SCTD shall not be applied.

The SCTD open loop downlink transmit diversity scheme for beacon channels is shown in figure 10, exemplary for the P-CCPCH. Channel coding, rate matching, interleaving and bit-to-symbol mapping are performed as in the non-diversity mode. In TxDiversity mode the beacon channel that is allocated to code $c_{16}^{(k=1)}$ is spread with the channelisation codes $c_{16}^{(k=1)}$ and $c_{16}^{(k=3)}$ and scrambled with the cell specific scrambling code. The beacon channel that is allocated to code $c_{16}^{(k=2)}$ is spread with the channelisation codes $c_{16}^{(k=2)}$ and $c_{16}^{(k=4)}$ and scrambled with the cell specific scrambling code. The spread sequences on code $c_{16}^{(k=3)}$ and code $c_{16}^{(k=4)}$ are then transmitted on the diversity antenna. The power applied to each antenna shall be equal.

The use of SCTD will be indicated by higher layers.

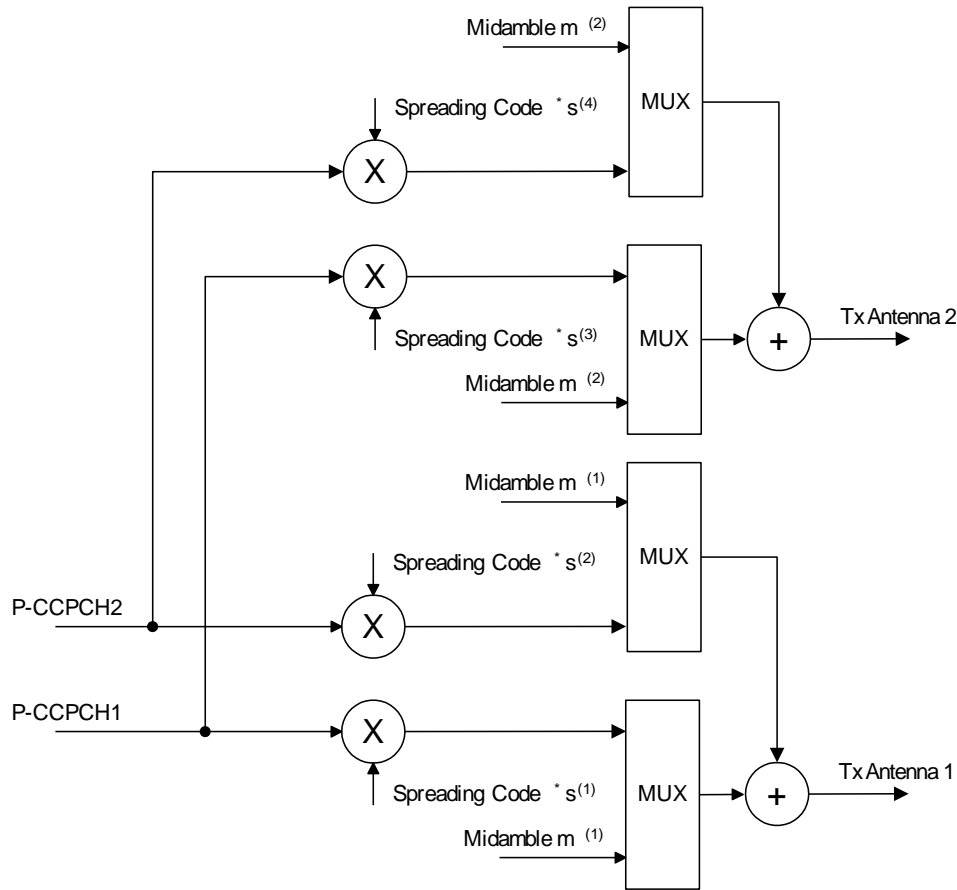

* Spreading by $s^{(k)}$ means channelisation by $c^{(k)}$ and cell specific scrambling

Figure 10: Block Diagram of the transmitter (SCTD) in 1.28 Mcps TDD, exemplary for the P-CCPCH

5.6 Random Access Procedure

The physical random access procedure described below is invoked whenever a higher layer requests transmission of a message on the RACH. The physical random access procedure is controlled by primitives from RRC and MAC.

5.6.1 Definitions

$FPACH_i$: The i^{th} FPACH number parameter i indicates the position of the FPACH, the first position is corresponding to the first instance defined in IE “PRACH system information list” (see [15]).

L_i : Length of RACH transport blocks associated to $FPACH_i$ in sub-frames

N_{RACH_i} : The number of PRACHs associated to the i^{th} FPACH

- n_{RACHi} : The number of a P-RACH associated to the i^{th} F-PACH ranging from 0 to $N_{RACHi}-1$
- M : Maximum number transmissions in the UpPCH
- WT : Maximum number of sub-frames to wait for the network acknowledgement to a sent signature
- SFN' : The sub-frame number counting the sub-frames. At the beginning of the frame with the system frame number $SFN=0$ the sub-frame number is set to zero.

5.6.1A UpPCH sub-channel

In order to separate different ASCs, UpPCH has N sub-channels associated with it (numbered from 0 to $N-1$). N may be assigned the value 1,2,4, or 8 by higher layer signaling.

- Sub-channel i for UpPCH is defined as the UpPTS timeslot in the sub_frame where $SFN' \bmod N = i$. Where SFN' : the sub-frame number counting the sub-frames. At the beginning of the frame with the system frame number $SFN=0$ the sub-frame number is set to zero.

The following figure illustrates the eight possible sub channels for the case, $N=8$.

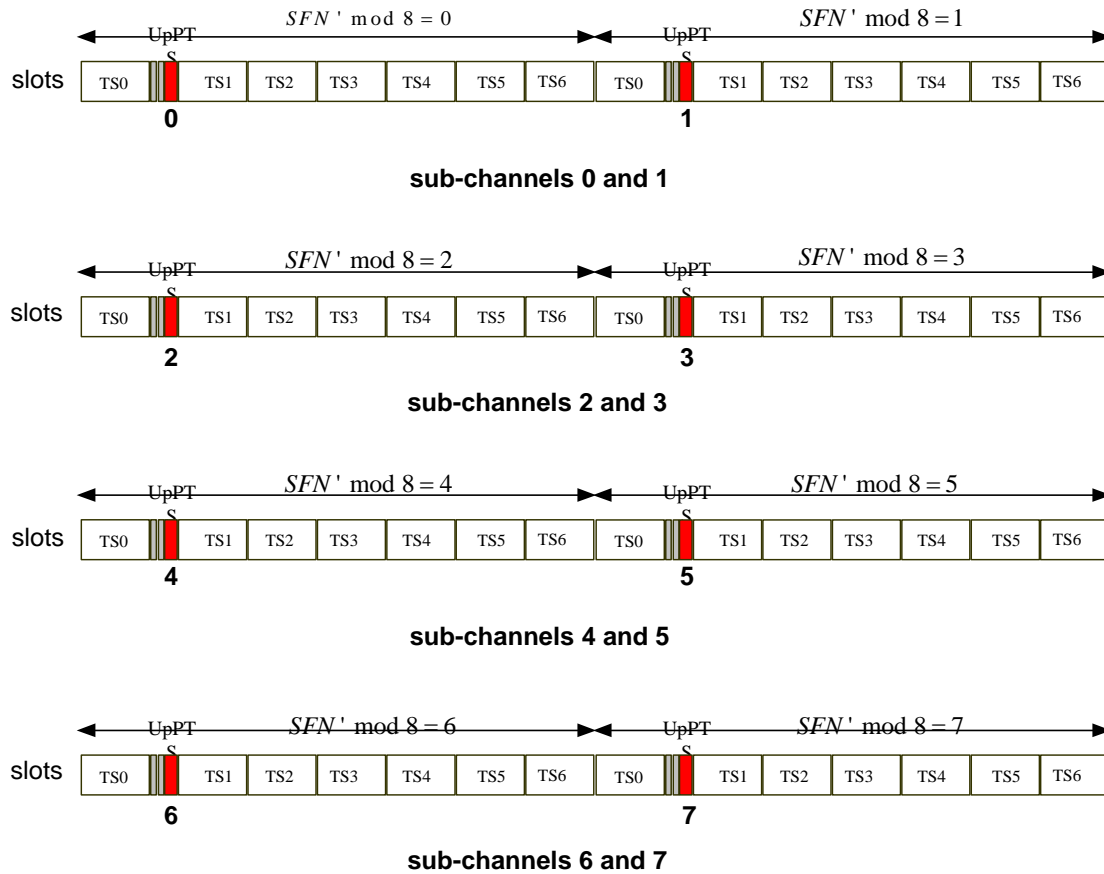

Figure 10A : Example of UpPCH subchannels

5.6.2 Preparation of random access

When the UE is in idle mode, it will keep the downlink synchronisation and read the system information. From the used SYNC-DL code in DwPCH, the UE will get the code set of 8 SYNC-UL codes (signatures) assigned to UpPCH for random access.

The description (codes, spreading factor, midambles, time slots) of the P-RACH, F-PACH, S-CCPCH (carrying the FACH transport channel) channel; mapping relation of RACH and F-PACH; ASC (available SYNC-UL sequences and available sub-channels) sets for each RACH are broadcast on the BCH.

Thus, when sending a SYNC-UL sequence, the UE knows which FPA CH resource, P-RACH resources and S-CCPCH resources will be used for the access.

The physical random access procedure described in this sub-clause is initiated upon request from the MAC sub-layer (see [18] and [19]).

Before the physical random-access procedure can be initiated, Layer 1 shall receive the following information by a CPHY-TrCH-Config-REQ from the RRC layer:

- The uplink access position by higher layers.
- The association between which signatures and which FPA CHs; which FPA CHs and which PRA CHs; including the parameter values for each listed physical channel.
- The length L_i of a RACH message associated to FPA CH_i can be configured to be either 1 or 2 or 4 sub-frames corresponding to a length in time of either 5 ms or 10 ms or 20 ms.

NOTE 1: N_{RACH_i} PRA CHs can be associated with to FPA CH_i. The maximum allowed

N_{RACH_i} is L_i .

- The available UpPCH sub-channels for each Access Service Class (ASC);
- The set of Transport Format parameters for the PRA CH message;
- The "M" maximum number transmissions in the UpPCH;
- The "WT" maximum number of sub-frames to wait for the network acknowledgement to a sent signature; (1..4) the maximum value supported by Layer 1 is 4 sub-frames.
- The initial signature power "Signature_Initial_Power";
- The power-ramping factor Power Ramp Step [Integer];

The above parameters may be updated from higher layers before each physical random access procedure is initiated.

At each initiation of the physical random access procedure, Layer 1 shall receive the following information from the higher layers (MAC):

- The Transport Format to be used for the specific PRA CH message;
- The ASC for the specific Random Access procedure;
- The data to be transmitted (Transport Block Set).
- The type of random access

5.6.3 Random access procedure

The physical random-access procedure shall be performed as follows:

UE side:

- 1 Set the Signature Re-Transmission Counter to M.
- 2 Set the Signature transmission power to Signature_Initial_Power.
- 3 Based on the type of random access and the transport format indicated by MAC layer, an E-RUCCH or unique RACH used for the radio access is chosen, and then randomly select one UpPCH sub-channel and one signature respectively from the available ones for the given ASC. The random function shall be such that each of the allowed selections is chosen with equal probability.
- 4 Transmit the signature at UpPCH or other uplink access position indicated by higher layers using the selected UpPCH sub-channel at the signature transmission power. In the case that the Commanded Signature transmission Power exceeds the maximum allowed value, set the Signature transmission Power to the maximum allowed power.

- 5 After sending a signature, listen to the relevant FPACH for the next WT sub-frames to get the network acknowledgement. The UE will read the FPACH_i associated to the transmitted UpPCH only in the sub-frames fulfilling the following relation:

$(SFN' \bmod L_i) = n_{RACH_i}$; $n_{RACH_i} = 0, \dots, N_{RACH_i} - 1$, Here, FPACH to which UE should listen is decided according to the following formula:

$$FPACH_i = N \bmod M,$$

Where, N denotes the signature number (0..7) and M denotes the maximum number of FPACHs that defined in the cell.

- 6 In case no valid answer is detected in the due time: Increase the Signature transmission power by $\Delta P_0 = \text{Power Ramp Step [dB]}$, decrease the Signature Re-transmission counter by one and if it is still greater than 0, then repeat from step 3; else report a random access failure to the MAC sub-layer.
- 7 In case a valid answer is detected in the due time
- set the timing and power level values according to the indication received by the network in the FPACH_i
 - send at the sub-frame coming 2 sub-frames after the one carrying the signature acknowledgement, the RACH message on the relevant PRACH. In case L_i is bigger than one and the sub-frame number of the acknowledgement is odd the UE will wait one more sub-frame. The relevant PRACH is the $n_{RACH_i}^{\text{th}}$ PRACH associated to the FPACH_i if the following equation is fulfilled:

$$(SFN' \bmod L_i) = n_{RACH_i};$$

Here SFN' is the sub-frame number of the arrival of the acknowledgement.

Both on the UpPCH and on the PRACH, the transmit power level shall never exceed the indicated value signalled by the network.

Network side:

- The node B will transmit the FPACH_i associated with the received UpPCH only in the sub-frames fulfilling the following relation:

$$(SFN' \bmod L) = n_{RACH_i}; n_{RACH_i} = 0, \dots, N_{RACH_i} - 1,$$

Here, FPACH number i is selected according to the following formula based on acknowledged signature:

$$FPACH_i = N \bmod M,$$

Where, N denotes the signature number (0..7) and M denotes the maximum number of FPACH that defined in the cell.

- The Node B will not acknowledge UpPCHs transmitted more than WT sub-frames ago

At the reception of a valid signature:

- Measure the timing deviation with respect to the reference time T_{ref} of the received first path in time from the UpPCH and acknowledge the detected signature sending the FPACH burst on the relevant FPACH.

For examples on the random access procedure refer to Annex CB.

5.6.3.1 The use and generation of the information fields transmitted in the FPACH

The Fast Physical Access CHannel (FPACH) is used by the Node B to carry, in a single burst, the acknowledgement of a detected signature with timing and power level adjustment indication to a user equipment.

The length and coding of the information fields is explained in TS25.221 sub-clause 5A.3.3.1 .

5.6.3.1.1 Signature Reference Number

The Signature Reference Number field contains the number of the acknowledged signature. The user equipment shall use this information to verify whether it is the recipient of the FPACH message.

5.6.3.1.2 Relative Sub-Frame Number

The Relative Sub-Frame Number field indicates the current sub-frame number with respect to the sub-frame at which the acknowledged signature has been detected.

The user equipment shall use this information to verify whether it is the recipient of the FPACH message.

5.6.3.1.3 Received starting position of the UpPCH ($UpPCH_{POS}$)

The *received starting position of the UpPCH* ($UpPCH_{POS}$) field indirectly indicates to the user equipment the timing adjustment it has to implement for the following transmission to the network. The node B computes the proper value for this parameter according to the following rules: $UpPCH_{POS} = UpPCH_{Rpath} - UpPCH_{TS}$

where

$UpPCH_{Rpath}$: time of the reception in the Node B of the SYNC-UL to be used in the uplink synchronization process

$UpPCH_{TS}$: time instance 128 chips prior to the start of the UpPCH according to the Node B internal timing

This information shall be used by the UE to adjust its timing when accessing the network, as described in section [5.2 'Uplink Synchronisation'] .

5.6.3.1.4 Transmit Power Level Command for the RACH message

This field indicates to the user equipment the power level to use for the RACH message transmission on the FPACH associated P-RACH.

The network may set this value based on the measured interference level (I) (in dBm) on the specific PRACH and on the desired signal to interference ratio (SIR) (in dB) on this channel as follows:

Transmit Power Level Command for the PRACH ($PRX_{PRACH,des}$)

$PRX_{PRACH,des}$ is the desired receive power level on the PRACH.

The UE shall add to this value the estimated path-loss to compute the power level to transmit for the PRACH.

5.6.3A E-RUCCH procedure

Requests for the transmission of an E-RUCCH are controlled by higher layers [18].

The available eight SYNC_UL signatures on the primary carrier in a cell is divided into two subsets, one for the access of RACH information and the other for the access of E-RUCCH information. The available eight SYNC-UL signature on the secondary frequencies in cell are all for the access of E-RUCCH information.

When a Node B detects a SYNC_UL signature and acknowledges it on the related FPACH, it should do some recordings, including the FPACH channel number, the sub-frame on which the acknowledgement is sent and the SYNC_UL signature number. When a PRACH or E-RUCCH comes from a UE, the Node B should derive the related FPACH and the sub-frame on which the acknowledgement was sent for the UE and find the right record. The signature number in the record can help the Node B know the access type.

Random access procedure for enhanced uplink is basically same as random access procedure in subclause 5.6.3, only adding some new definitions.

L_{iE} is the Length of E-RUCCH information transport blocks associated to $FPACH_i$ in sub-frames.

N_{RACH_i} is the number of PRACHs associated to the i th FPACH.

$N_{E-RUCCH_i}$ is the number of E-RUCCHs associated to the i th FPACH and $N_{E-RUCCH_i}$ equals to $\min\{N_{RACH_i}, L_{iE}\}$.

When SF of PRACH code equals to 16, L_{iE} will be 2, otherwise L_{iE} will be 1.

When SF of PRACH code equals to 4, SF of E-RUCCH will be 8, otherwise E-RUCCHs has the same SF with PRACH.

When $n_{E-RUCCHi}$ equals to n_{RACHi} , E-RUCCH will share the same code resource with PRACH. And when SF of PRACH code equals to 4, the code resource assigned to PRACH including two codes (code i and code $i+1$) of SF 8, E-RUCCH can use the i th code of SF 8.

If $FPACH_i$ sent an acknowledgement for E-RUCCH information, the sub-frames on which an acknowledgement is sent on $FPACH_i$ is fulfilling the following relation:

$$(SFN' \bmod L_{iE}) = n_{E-RUCCHi}; n_{E-RUCCHi} = 0, \dots, N_{E-RUCCHi} - 1,$$

Where, SFN' is the sub-frame number of the acknowledgement on $FPACH$

Accordingly, the code resource assigned to PRACH may be used by PRACH or E-RUCCH, we should make two prescript avoiding the collision between PRACH and E-RUCCH.

When Node B sent a $FPACH_i$ for $PRACH_{n_{RACHi}}$ in sub frame K , Node B could not send a $FPACH_i$ for $E - RUCCH_{n_{E-RUCCHi}}$ before sub frame $K + L_i$;

When Node B sent a $FPACH_i$ for $E - RUCCH_{n_{E-RUCCHi}}$ in sub frame K , Node B could not send a $FPACH_i$ for $PRACH_{n_{RACHi}}$ before sub frame $K + L_{iE}$.

The interval between the acknowledgement on $FPACH$ and transmission of E-RUCCH is fixed for a UE. The UE will send at the sub-frame coming 2 sub-frames after the one carrying the signature acknowledgement. In case L_{iE} is bigger than one and the sub-frame number of the acknowledgement is odd the UE will wait one more sub-frame.

The transmission power and the transmission timing are set according to subclause 5.1.1.7 and 5.2.7 respectively.

5.6.4 Random access collision

When a collision is very likely or in bad propagation environment, the Node B does not transmit the $FPACH$ or cannot receive the SYNC-UL. In this case, the UE will not get any response from the Node B. Thus the UE will have to adjust its Tx time and Tx power level based on a new measurement and send a SYNC-UL again after a random delay.

Note that at each (re-)transmission, the SYNC-UL sequence and the UpPCH sub-channel will be randomly selected again by the UE.

Note: Due to the two-step approach a collision most likely happens on the UpPCH. The resources allocated to PRACH and E-RUCCH are virtually collision free. This two-step approach will guarantee that the RACH resources can be handled with conventional traffic on the same UL time slots.

5.7 Node B Synchronisation Procedure over the Air

An option exists to use the regular DwPCH transmissions to achieve and maintain Node B synchronisation [20]. This optional procedure is based on measurements of DwPCHs from neighbouring cells according to an RNC schedule. The timing offset measurements are reported back to the RNC for processing. The RNC generates cell timing updates that are transmitted to the Node Bs and cells for implementation (common with the 3.84 Mcps TDD option). Alternatively the RNC may indicate that the NodeB shall autonomously adjust the cell timings. Two distinct phases can be distinguished for Node B synchronisation over the air, with a potential additional sub-phase involving late entrant cells.

5.7.1 Initial Synchronisation

Common with 3.84 Mcps TDD, see [4.9.2 Initial Synchronisation], however, the regular DwPCHs are used as cell sync bursts.

5.7.2 Steady-State Phase

Common with 3.84 Mcps TDD, see [4.9.3 Steady-State Phase], however, the regular DwPCHs are used as cell sync bursts. If the NodeB adjusts the cell timings autonomously, it shall take into account the propagation delay, signaled by the RNC.

5.7.3 Late entrant cells

A procedure that may be used for introducing new cells into an already synchronised RNS involves the continuous measurement of the DwPCHs of the neighbouring cells by the late entrant cell. The RNC may use this information to adjust the late entrant cell sufficiently to allow the cell to enter steady state phase.

5.8 Idle periods for IPDL location method

5.8.1 General

To support time difference measurements for location services, idle periods can be created in the downlink (hence the name IPDL) during which time transmission of the DwPCH from a Node B is temporarily ceased. During these idle periods the visibility of neighbour cells from the UE is improved.

The idle periods are arranged in a determined pattern according to higher layer parameters. An idle period has a duration of one DwPTS.

In general there are two modes for these idle periods:

- Continuous mode, and
- Burst mode

In continuous mode, the idle periods are active all the time. In burst mode the idle periods are arranged in bursts where each burst contains enough idle periods to allow a UE to make sufficient measurements for its location to be calculated. The bursts are separated by a period where no idle periods occur. The time difference measurements can be performed on any channel.

5.8.2 Parameters of IPDL

The following parameters are signalled to the UE via higher layers:

- IP_Status:** This is a logic value that indicates if the idle periods are arranged in continuous or burst mode.
- IP_Spacing:** The number of 10 ms radio frames between the start of a radio frame that contains an idle period and the next radio frame that contains the next idle period.
- IP_Start:** The number of the first frame with idle periods. In case of continuous mode IP_Start is the SFN of the first frame with idle periods and in case of burst mode IP_Start defines the number of frames after Burst_Start with the first frame with idle periods.
- IP_Sub:** Indicates whether the idle period is to occur in the odd, the even or both the odd and even 5 ms sub-frames of the 10 ms idle frame.

Additionally in the case of burst mode operation the following parameters are also communicated to the UE.

- Burst_Start:** Specifies the start of the first burst of idle periods. $256 \times \text{Burst_Start}$ is the SFN where the first burst of idle periods starts.
- Burst_Length:** The number of idle periods in a burst of idle periods.
- Burst_Freq:** Specifies the time between the start of a burst and the start of the next burst. $256 \times \text{Burst_Freq}$ is the number of radio frames between the start of a burst and the start of the next burst.

5.8.3 Calculation of idle period position

In burst mode, burst #0 starts in the radio frame with SFN = $256 \times \text{Burst_Start}$. Burst #n starts in the radio frame with SFN = $256 \times \text{Burst_Start} + n \times 256 \times \text{Burst_Freq}$ ($n = 0, 1, 2, \dots$). The sequence of bursts according to this formula continues up to and including the radio frame with SFN = 4095. At the start of the radio frame with SFN = 0, the burst sequence is terminated (no idle periods are generated) and at SFN = $256 \times \text{Burst_Start}$ the burst sequence is restarted with burst #0 followed by burst #1 etc., as described above.

Continuous mode is equivalent to burst mode, with only one burst spanning the whole SFN cycle of 4096 radio frames, this burst starts in the radio frame with SFN = 0. In case of continuous mode the parameter IP_Start defines the first frame with idle periods.

The DwPTS, that has to be idle, is defined by two values: IP_Frame(x) and IP_Sub. IP_Frame(x) defines the x^{th} frame within a burst in which subframe with the number IP_Sub has to be switched off.

The actual frame with idle periods within a burst is calculated as follows:

$$\text{IP_Frame}(x) = \text{IP_Start} + (x-1) \times \text{IP_Spacing} \text{ with } x = 1, 2, 3, \dots$$

Figure 11 below illustrates the idle periods for the burst mode which shows the case that both subframes within each frame have DwPTS as an idle period.

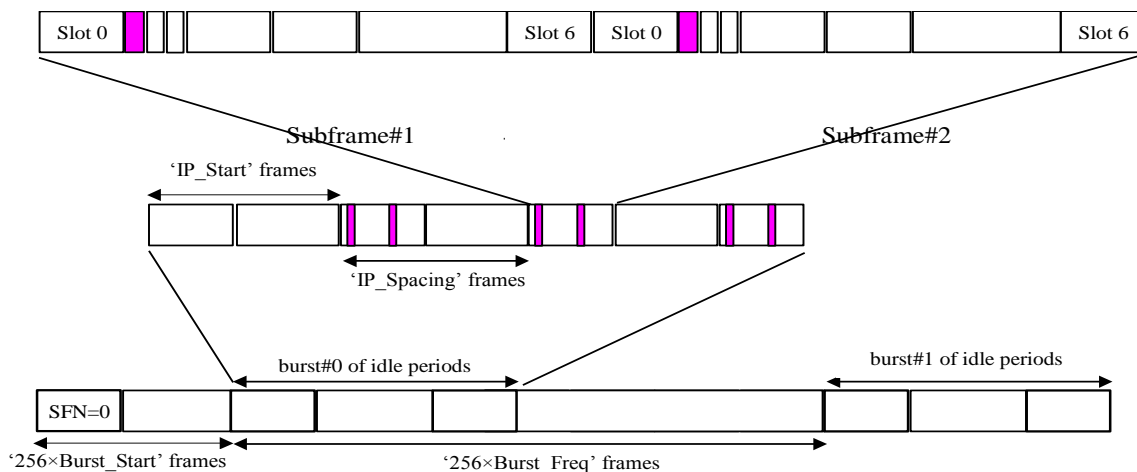

Figure 11: Idle periods of burst mode for 1.28Mcps TDD

5.9 HS-DSCH Procedure in CELL_DCH state

5.9.1 Link Adaptation Procedure

For HS-DSCH, the modulation scheme and effective code rate shall be selected by higher layers located within the Node B. This shall be achieved by appropriate selection of an HS-DSCH transport block size, modulation format and resources by higher layers. If the UE is configured in MIMO mode, higher layers may select the number of data streams, i.e. single or dual stream HS-DSCH transmission, and the transport block size, modulation format and resources for each stream. The Node B shall decide the number of data streams based on the uplink channel estimation and CQI reports from the UE. If UE supports multi-carrier HS-DSCH reception, higher layers may select multiple carriers to transfer data. Carriers selection may be based on CQI reports from the UE. If UE supports multi-carrier HS-DSCH transmission, UE shall report the CQI information of every carrier via HS-SICH.

The overall HS-DSCH link adaptation procedure consists of *two parts*:

Node B procedure:

- 1) The NodeB transmits HS-SCCH carrying a UE identity identifying the UE to which HS-DSCH TTI is to be granted. In case of HS-DSCH transmissions in consecutive TTIs to the same UE, the same HS-SCCH shall be used for associated signalling. If the UE is configured in MIMO mode, the Node B shall determine appropriate HS-SCCH type for single or dual stream HS-DSCH transmission. If UE supports multi-carrier HS-DSCH reception, above HS-SCCH detection procedure applied on each independent carriers.
- 2) The NodeB transmits HS-DSCH to the UE using the grant indicated in the HS-SCCH. If UE supports multi-carrier HS-DSCH reception, the mapping relation between HS-SCCH and its associated HS-DSCH is set by higher layers.

- 3) Upon receiving the HS-SICH from the respective UE, the status report (ACK/NACK and CQI) shall be passed to higher layers. If UE supports multi-carrier HS-DSCH reception, the mapping relation between HS-SICH and its associated HS-DSCH is set by higher layers.

UE procedure:

- 1) When indicated by higher layers, the UE shall start monitoring all HS-SCCHs that are in its HS-SCCH set as signalled to it by higher layers. The information carried on the HS-SCCH is described in [8]. If UE supports multi-carrier HS-DSCH reception, the monitoring HS-SCCH set is signalled by higher layers.
- 2) In the case that a HS-SCCH is identified to be correct by its CRC, the UE shall read the HS-PDSCHs indicated by the HS-SCCH. If the UE is configured in MIMO mode, UE may acquire HS-PDSCH resource allocation information of each stream according to the associated HS-SCCH. If UE supports multi-carrier HS-DSCH reception, UE may acquire HS-PDSCH resource allocation information of each carrier according to the associated HS-SCCHs, the mapping relation between every HS-SCCH and its associated HS-PDSCH is signalled by higher layers. In the case that a HS-SCCH is identified to be incorrect, the UE shall discard the data on the HS-SCCH and return to monitoring.
- 3) After reading the HS-PDSCHs, the UE shall generate an ACK/NACK message and transmit this to the NodeB in the associated HS-SICH, along with the most recently derived CQI. If the UE is configured in MIMO mode, the CQI and ACK/NACK of each stream are transferred via the associated HS-SICH. If UE supports multi-carrier HS-DSCH reception, the CQI and ACK/NACK of every carrier are transferred via individual HS-SICH.

The mapping of HS-PDSCH channelisation code set and timeslot information carried by the HS-SCCH for a given HS-DSCH TTI is described in [9].

For a given allocation of HS-PDSCH resources to a UE for a specific HS-DSCH TTI, the following shall apply:

- If timeslot information on HS-SCCH indicates two or more timeslots, none of these timeslots shall comprise a beacon channel.
- If timeslot information on HS-SCCH indicates a single timeslot and this timeslot comprises a beacon channel then:
 - The Node-B shall not indicate SF=1 for any HS-PDSCH resource.
 - The set of HS-PDSCH resources allocated by the Node-B to a UE shall exclusively comprise either beacon function or non-beacon function physical channels. The Node B shall therefore not allocate both beacon function and non-beacon function physical channels within the beacon timeslot to the UE. If the HS-DSCH for a specific HS-DSCH TTI is mapped to the beacon channel, this shall be signalled using $k_{start} = 1$ and $k_{stop} = 1$. For a definition of the first and last allocated channelisation code indices k_{start} and k_{stop} on HS-SCCH refer to [9].
 - When SCTD antenna diversity is applied to the beacon channel, then the presence of channelisation code $C_{16}^{(1)}$ within the channelisation code set information on HS-SCCH shall implicitly indicate the presence of channelisation code $C_{16}^{(2)}$.

5.9.2 HS-DSCH Channel Quality Indication Procedure

For the HS-SICH associated to the HS-SCCH command for allocation or release of the semi-persistent HS-PDSCH resources and HS-SCCH command for activation or deactivation of DRX and the HS-SICH associated to HS-SCCH type1 or HS-SCCH type 4 or HS-SCCH type 8 with transport block size information set to all zeros, UE shall feedback ACK and CQI on HS-SICH with RTBS equals to zero.

The channel quality indicator (CQI) provides the Node B with an estimate of the code rate that would have maximized the single-transmission throughput of the previous HS-DSCH transmission if decoded in isolation. The CQI report requires to be referenced to a given set of HS-PDSCH resources by the Node B, but note that the UE is not restricted to making measurements only on these reference resources when deriving a given CQI. The reference resources for a CQI report shall be a set of HS-PDSCH resources that were received by the UE in a single TTI, and contain a complete transport block. These resources will be known to the Node B from the relative timings of the HS-SICH carrying the CQI and previous HS-DSCH transmissions to the UE.

The CQI consists of two fields; a Recommended Transport Block Size (RTBS) and a Recommended Modulation Format (RMF). The UE shall use the same mapping table for these fields as is being used for the time slot information and modulation scheme information fields respectively of the HS-SCCH [18]. If the UE is configured in MIMO mode, the HS-SICH shall consist of the CQI reports of each stream, i.e. the RTBS and RMF of each stream.

The reporting procedure is as follows:

1. The UE receives a message on an HS-SCCH telling it which resources have been allocated to it for the next associated HS-DSCH transmission.
2. The UE reads the associated HS-DSCH transmission, and makes the necessary measurements to derive a CQI that it estimates would have given it the highest single-transmission throughput for the allocated resources whilst achieving a BLER of no more than 10 %. If the UE is configured in MIMO mode, the CQI would have given the highest single-transmission throughput for each stream respectively in the allocated resources whilst achieving BLER of each stream of no more than 10% .

BLER, in this context, is defined as the probability that a transport block transmitted using the RTBS and RMF is received in error if decoded in isolation. For the purposes of this calculation, it shall be assumed that the transport block that would be transmitted with these parameters would use redundancy version parameters $s = 1$ and $r = 0$. Note that, by this definition, a UE shall never report a CQI that corresponds to a code rate greater than unity.

Using this definition of BLER, single-transmission throughput shall be defined as follows :

$$\text{single-transmission throughput} = (1 - \text{BLER}) \times \text{RTBS}$$

If the UE is configured in MIMO mode, the single-transmission throughput shall be defined as the sum of each stream throughput.

3. The CQI report derived from a given HS-DSCH transmission shall be reported to the Node B in the next HS-SICH available to the UE following that HS-DSCH transmission, unless that HS-SICH immediately follows the last allocated HS-DSCH timeslot, in which case the subsequent available HS-SICH shall be used by the UE. This HS-SICH may not necessarily be the same HS-SICH that carries the ACK/NACK information for that HS-DSCH transmission. The UE shall always transmit the most recently derived CQI in any given HS-SICH, which may mean that some CQI reports are discarded without being transmitted to the Node B.

5.9.3 HS-SCCH monitoring procedure

If `HS_SCCH_DRX_Active` is FALSE, UE shall monitor a set of HS-SCCHs as follows.

For 1.28Mcps TDD, in a multi-frequency HS-DSCH cell, a UE divides its HS-SCCH set into one or more HS-SCCH subsets; in each HS-SCCH subset all HS-SCCHs are associated with the same frequency's HS-PDSCH. When indicated by higher layers, the UE shall start monitoring all HS-SCCHs in all HS-SCCH subsets to acquire the configuration information of HS-PDSCHs. In the case that one HS-SCCH is detected carrying its UE identity, the UE shall skip monitoring the remaining HS-SCCHs in this HS-SCCH subset, and restrict its monitoring only to previously detected HS-SCCH in the following TTIs. The UE shall set all HS-SCCHs carrying its UE identity in all HS-SCCH subsets into an active set, and set all HS-SCCH subsets in which no HS-SCCH carries its UE identity into a remaining set.

In the case that the multi-carrier number (as described in [15]) is not configured by high layers, a UE shall always monitor all HS-SCCH subsets. Otherwise, the UE may skip monitoring remaining HS-SCCH subsets when the number of HS-SCCHs carrying its UE identity, i.e. the number of HS-SCCHs in the active set, is equal to the configured value.

During the following TTIs, the UE shall update and maintain the active set and the remaining set. If one or more HS-SCCHs in the active set do not carry its UE identity, the UE shall remove them from the active set and set their corresponding HS-SCCH subsets into remaining set. Meanwhile, if one or more HS-SCCHs in remaining sets are detected carrying its UE identity, the UE shall set these founded HS-SCCHs into the active set and remove their corresponding HS-SCCH subsets from the remaining set.

If `HS_SCCH_DRX_Active` is TRUE, UE shall monitor a set of HS-SCCHs in the subframes according to rules defined in the subclause 5.13.

5.9A HS-DSCH Procedure in CELL_FACH state

5.9A.1 Link Adaptation Procedure

In HS-DSCH reception in CELL_FACH state, the measurement result on RACH can be used for initial link adaptation. Only when UE is allocated a dedicated UE identity, the ACK/NACK feedback is provided and a measurement report is associated with each HS-DSCH link adaptation procedure. When downlink transmission is recommenced following a transmission pause, Node B shall order UE to perform the uplink synchronization procedure of [subclause 5.3.3.2 Establishment of uplink synchronization] in case it detects the UE is out of synchronization. If Node B receives E-RUCCH from the UE, the Node B can then resume the HS-DSCH transmission for the UE, and the link adaptation procedure is the same as that in CELL_DCH state, cf. 5.9.1.

The Node B shall always use HS-SCCH type 1 for BCCH transmission. For the UEs in CELL-FACH state which are configured in MU-MIMO mode, the UE shall detect the HS-SCCH type of the HS-SCCHs carry consistent control information via UE ID, i.e., the HS-SCCH shall be HS-SCCH type 1 if the UE ID is BCCH specific H-RNTI while the HS-SCCH shall be HS-SCCH type 4 if the UE ID is its dedicated H-RNTI.

5.9A.2 HS-DSCH Channel Quality Indication Procedure

If the UE is configured without dedicated UE identity, the UE shall not transmit an HS-SICH. If the UE is configured with a dedicated UE identity, but the HS-SCCH is an uplink synchronization establishment order, then its associated HS-SICH shall not be transmitted. Otherwise, the channel quality indication shall be transmitted on HS-SICH, and the HS-DSCH channel quality indication procedure is the same as that in CELL_DCH state of 1.28Mcps TDD, cf. 5.9.2.

5.9A.3 HS-SCCH monitoring procedure

When HS_DSCH_DRX_CELL_FACH_STATUS is FALSE (as described in [15]), UE shall monitor HS-SCCHs continuously as in CELL_DCH state cf. 5.9.3.

When HS_DSCH_DRX_CELL_FACH_STATUS is TRUE (as described in [15]), UE shall monitor HS-SCCHs according to the following rules:

- Once the UE receives HS-SCCH carrying its dedicated identity and feeds back on HS-SICH, the UE shall monitor HS-SCCHs continuously for a period of inactivity time (T321) configured by higher layer.
- Once the UE receives HS-SCCH order carrying synchronization establishment command and accomplishes the uplink synchronization establishment, the UE shall monitor HS-SCCHs continuously for a period of inactivity time (T321) configured by higher layer.
- Whenever the UE monitors E-AGCH continuously as described in 5.11.3A, the UE shall always monitor HS-SCCHs.
- The UE shall monitor HS-SCCHs for the RX burst length of the DRX Cycle and may choose not to monitor HS-SCCHs for the rest of the time of the DRX Cycle (as described in [15]).

5.9B HS-DSCH Procedure in CELL_PCH or URA_PCH state

5.9B.1 Link Adaptation Procedure

In HS-DSCH reception in CELL_PCH and URA_PCH state, after receiving a paging indication on PICH for its specific PI, the UE with a stored dedicated UE identity shall start monitoring HS-SCCH while the UE without a dedicated UE identity shall start monitoring the HS-PDSCH(s). The HS-PDSCH physical resource and associated signalling are broadcasted in the system information.

In a multi-frequency cell, HS-DSCH reception in CELL_PCH and URA_PCH is only on primary frequency.

Node B procedure:

The timing relation of the PICH frame to the associated HS-SCCH subframe or the HS-DSCH is described in 7.2.7.3 and 7.2.7.4 of [8].

If the UE is configured with a dedicated UE identity, the Node B shall use the following procedures:

- The Node B shall transmit the HS-SCCH order associated with the PICH frame using the dedicated UE identity.
- If the Node B has received E-RUCCH, the Node B considers that the UE has transitioned to CELL_FACH state.

If the UE is configured without dedicated UE identity, the Node B shall use the following procedures:

- The Node B shall not transmit an HS-SCCH.
- The Node B shall transmit an HS-DSCH transport block in the HS-DSCH subframe with parameters configured by RRC layer.
- The Node B shall retransmit the HS-DSCH transport block ($2 \cdot m - 1$) times in the next contiguous subframes without transmitting HS-SCCH.
- The Node B shall use QPSK modulation for each transmission of HS-PDSCH.
- For the first transmission and retransmission, the redundancy and constellation version of the HS-DSCH transport block are 0, 3, 4, 7, 0, 3...

UE procedure:

If the UE has detected a paging indication intended for this UE, the UE shall perform the following actions:

If the UE is configured with a dedicated UE identity, UE shall receive the corresponding HS-SCCH subframes:

- if the UE detects that one of the monitored HS-SCCHs in a set of associated HS-SCCH subframes carries consistent control information (HS-SCCH order) intended for this UE, the UE shall initiate the uplink synchronization procedure on primary frequency and transition to CELL_FACH state.
- if the UE detects that one of the monitored HS-SCCHs in a set of associated HS-SCCH subframes carries consistent control information (HS-SCCH type 1 carrying BCCH specific H-RNTI), the UE shall receive the corresponding HS-DSCH based on the association and timing between HS-SCCH and HS-DSCH.
- if the UE does not detect any HS-SCCH carries consistent control information intended for this UE in the M subframes, the UE shall resume the DRX operation.

If the UE is configured without dedicated UE identity and there is no legacy PCH channel, UE shall receive the corresponding HS-DSCH TTIs and:

- consider that paging message is retransmitted in $2 \cdot m$ subframes, the parameter m is the number of frame that a paging sub-channel occupies.
- combine retransmissions to the same HARQ buffer.
- pass the data to higher layers if the CRC is correct after decoding the data.
- resume the DRX operation if the CRC fails after receiving $2 \cdot m$ subframes.

5.9B.2 HS-DSCH Channel Quality Indication Procedure

The UE in CELL_PCH or URA_PCH state does not report CQI via HS-SICH.

5.9B.3 HS-SCCH monitoring procedure

The UE with a stored dedicated UE identity shall monitor HS-SCCH in M sub-frames after receiving its specific paging indication on PICH (as described in [8]).

The UE without a dedicated UE identity shall not monitor any HS-SCCH.

5.10 Macro-diversity procedure

The macro-diversity procedure is the same as that of 3.84 Mcps TDD, cf. 4.12 Macro-diversity procedure.

5.11 E-DCH Procedure

5.11.1 ACK/NACK detection

The physical layer in the UE shall detect ACK or NACK contained within the E-HICH. Which E-HICH is associated with the corresponding E-DCH transmission is defined in [8].

5.11.2 Serving and neighbour cell pathloss metric derivation

The UE shall be capable of measuring the P-CCPCH RSCP of the serving cell and of intra-frequency and inter-frequency neighbour cells in accordance with [11]. The P-CCPCH transmit power (P_{ref}) of the serving cell and of each neighbour cell (with a primary or a secondary frequency being the same as UE's current working frequency) in the monitored neighbour cell list shall be signalled by higher layers to the UE in order that the UE may estimate the mean pathloss to the serving cell (L_{serv}) and to each of the N neighbour cells in the monitored neighbour cell list (L_1, L_2, \dots, L_N). The pathloss used in the following formulas is a linear value, but not a logarithmic (dB) value.

Higher layers shall configure the UE to use SNPL reporting type 1 or SNPL reporting type 2. In accordance with the SNPL reporting type, the UE shall be capable of forming a metric corresponding to:

$$\Phi = \frac{1}{\sum_{n=1}^N L_{serv} / L_n} \quad \{\text{for SNPL reporting type 1}\}$$

$$\Phi = \frac{\min(L_n)}{L_{serv}} \quad \{\text{for SNPL reporting type 2}\}$$

The metric ϕ shall be converted into a logarithmic (dB) value Q and shall be mapped to a Serving and Neighbour Cell Pathloss (SNPL) index according to table 2b. The SNPL index is supplied to and used by higher layers (see [18]).

Table 2b: SNPL mapping

$Q = 10 * \log_{10}(\phi)$	SNPL index
$Q < -10$	0
$-10 \leq Q < -8$	1
$-8 \leq Q < -6$	2
$-6 \leq Q < -5$	3
$-5 \leq Q < -4$	4
$-4 \leq Q < -3$	5
$-3 \leq Q < -2$	6
$-2 \leq Q < -1$	7
$-1 \leq Q < 0$	8
$0 \leq Q < 1$	9
$1 \leq Q < 2$	10
$2 \leq Q < 3$	11
$3 \leq Q < 4$	12
$4 \leq Q < 5$	13
$5 \leq Q < 6$	14
$6 \leq Q < 7$	15
$7 \leq Q < 8$	16
$8 \leq Q < 9$	17
$9 \leq Q < 10$	18
$10 \leq Q < 11$	19
$11 \leq Q < 12$	20
$12 \leq Q < 13$	21
$13 \leq Q < 14$	22
$14 \leq Q < 15$	23
$15 \leq Q < 16$	24
$16 \leq Q < 17$	25

$17 \leq Q < 18$	26
$18 \leq Q < 20$	27
$20 \leq Q < 22$	28
$22 \leq Q < 24$	29
$24 \leq Q < 26$	30
$26 \leq Q$	31

If the higher layer signalling information regarding the required P-CCPCH reference power of all the neighbour cells or the serving cell is not available for the UEs staying in CELL_DCH state, e.g. when the serving cell changes or the working frequency changes within the serving cell, but the intra-frequency cell list and/or the inter-frequency cell list has not been updated, the UE shall return an SNPL index value of 9.

For the UEs staying in CELL_DCH state, if the intra-frequency cell list and/or the inter-frequency cell list have been updated, before the pathloss of all of the cells that SNPL calculation involves is derived, the UE shall return an SNPL index value of 9.

After receiving the related cell information, if neighbour cell indicated for SNPL reporting in the monitored neighbour cell list mentioned above is null, the UE shall return an SNPL index value of 9.

For the UE configured with multi-carrier E-DCH transmission, all the uplink E-DCH carriers of the UE can be divided into one or more carrier group(s). The neighbour cells which are used for SNPL calculation for each carrier in one carrier group are the same. For physical layer of UE, the carrier group information shall be indicated by higher layer to make it know that which uplink E-DCH carriers are in the same carrier group. For each carrier group, the SNPL is calculated in reference to one carrier of the carrier group and is shared by all the carriers which are in the same carrier group. Higher layers shall configure the UE to use SNPL reporting type 1 or SNPL reporting type 2 for all carrier groups. In accordance with the SNPL reporting type, the UE shall be capable of selecting the corresponding formula from the above two formulas to calculate the SNPL for one carrier group, where L_{serv} is the mean pathloss to the serving cell (L_{serv}) and L_n is the mean pathloss to the n-th cell of the N neighbour cells (with a primary or a secondary frequency being the same as one of the frequencies in the current carrier group) in the monitored neighbour cell list.

For multi-carrier E-DCH transmission, the UE shall return an SNPL index value of 9 for one carrier when the UE is under the same scenarios as listed above for UE's returning an SNPL index value of 9.

5.11.3 E-AGCH monitoring in CELL_DCH state

If E-AGCH DRX information is not configured by higher layers,

If the UE has semi-persistent E-PUCH resources, the UE shall keep monitoring a set of E-AGCHs continuously.

Otherwise, when the latest scheduling information UE sent indicates the TEBS equals zero and the UE has received the corresponding ACK on E-HICH, after continuing monitoring E-AGCH for a period of time configured by higher layers, the UE may stop monitoring E-AGCH if the UE has no E-DCH data (including retransmission data) to transmit. When the TEBS becomes larger than zero, the UE shall start monitoring E-AGCH after sending scheduling information indicating that the TEBS is larger than zero.

If the E-AGCH DRX information is configured by higher layers, the UE shall monitor E-AGCHs according to rules defined in the subclause 5.13.

5.11.3A E-AGCH monitoring in CELL_FACH state

For the UE with a stored dedicated UE identity in CELL_FACH state, when the latest scheduling information UE sent indicates the TEBS equals zero and the UE has received the corresponding ACK on E-HICH, after continuing monitoring E-AGCH for a period of time (T_{321}) configured by higher layers (as described in [15]), UE may stop monitoring E-AGCH if the UE has no E-DCH data (including retransmission data) to transmit. The TEBS is described in [18].

If the TEBS becomes larger than zero, UE shall start monitoring E-AGCH after sending scheduling information indicating that the TEBS is larger than zero.

For the UE without a dedicated UE identity in CELL_FACH state or in IDLE mode, UE shall stop monitoring E-AGCH outside the common E-RNTI Scheduling Window (as described in [18]).

5.12 MIMO operation of HS-DSCH

5.12.1 General procedure

This section applies only when a UE is configured in MIMO mode.

The general transmitter structure to support MIMO operation of HS-PDSCH transmission is shown in figure 11A. Channel coding, interleaving and spreading are done the same as in non-MIMO mode. The Node B scheduler can decide to transmit one or two transport blocks to a UE in one TTI. The spread complex valued signals are fed to both TX antenna branches, and weighted with precoding weights.

If the UTRAN schedules a single transport block to a UE in one TTI, it uses EBB (Eigenvector Based Beam-forming) or antenna selection for transmission of that transport block on the HS-PDSCH sub-frame. If the UTRAN schedules two transport blocks to a UE in one TTI, it uses two orthogonal precoding vectors to transmit the two transport blocks. The precoding vectors are generated by SVD (Singular Value Decomposition) of the channel matrix or grouped beam-forming to form the two beams. The PARC with two transmit antennas can be viewed as a special case, where the stream per antenna is transmitted independently.

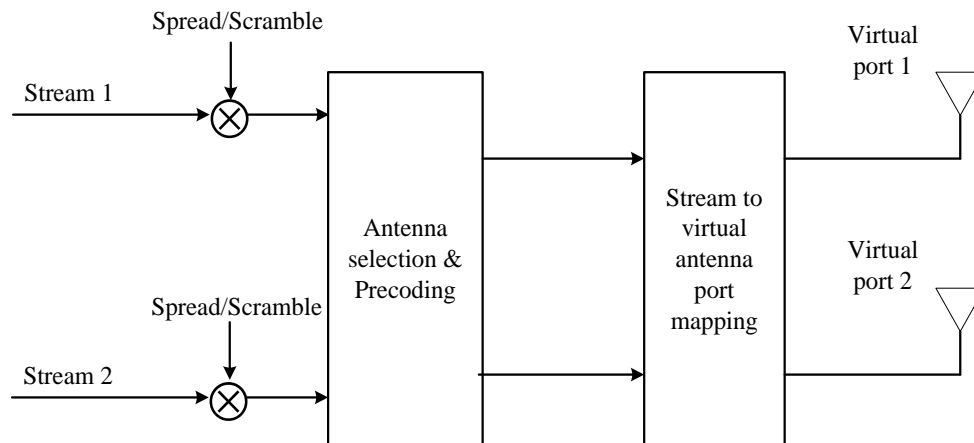

Figure 11A: The generic downlink transmitter structure to support MIMO operation for HS-PDSCH transmission.

The Node B estimates the uplink channels seen from each antenna by uplink physical channels or standalone midamble channel. The Node B scheduler decides whether to schedule one or two transport blocks to a UE in one TTI and what transport block size(s) and modulation scheme(s) to use for each of them. The Node B determines the precoding vectors applied on the HS-PDSCH sub-frame and forms the beams to the UE. The associated HS-SCCH type for single or dual stream HS-DSCH transmission is signaled to the UE. The UE transmits the CQI report and ACK/NACK of each stream to the Node B via the associated HS-SICH.

5.12.2 Identification of MIMO dual stream

When the UE is configured in MIMO mode and the dual stream transmission is adopted, the two streams are called stream1 and stream2 respectively. According to the special default midamble allocation scheme, the Node B shall allocate the pattern1 to stream1, and the pattern2 to stream2. The UE identifies and detects two transport blocks in one TTI according to the different patterns.

5.12.3 UE antennas Time Switched Transmission

When the UE is configured in MIMO mode, uplink time switched transmission at the UE with two antennas for uplink physical channels, i.e. HS-SICH, E-PUCH, DPCH and standalone midamble channel if configured by higher layers, is used for uplink channel estimation.

The UE switches the two antennas to transmit the uplink physical channels HS-SICH, E-PUCH, and DPCH and standalone midamble channel among the uplink timeslots which may belong to one TTI or multiple TTIs allocated by UTRAN. The downlink signaling HCSN and ECSN are used to guarantee the identification of the two UE antennas and the exact update of the two channel estimation vectors at Node B. Note that time switched transmission is not applied to the random access uplink physical channel.

If the standalone midamble channel is not configured, the UE antennas time switched transmission procedures for uplink physical channels are described below.

If the allocated resource for the UE includes multiple uplink timeslots in one TTI, the UE shall transmit the uplink physical channels in every timeslot by using the antenna selected according to the received downlink signaling value and the predefined relationship between UE and Node B. The details are as follows:

- ◆ If there is an HS-SICH in this TTI, the Node B implicitly informs the UE by HCSN on HS-SCCH which antenna shall be used to transmit HS-SICH. The UE shall use the antenna indicated by the parity of HCSN decimal value to transmit HS-SICH. Based on the reference antenna carrying HS-SICH, the UE switches the transmit antennas in turn for the consequent uplink transmission in this TTI;
- ◆ Else if there is no HS-SICH but scheduled E-PUCH in this TTI, the Node B implicitly informs UE by ECSN on E-AGCH which antenna shall be used to transmit the first timeslot of E-PUCH. UE shall use the antenna indicated by the parity of ECSN decimal value to transmit first timeslot of E-PUCH. And based on the reference antenna carrying the first timeslot of E-PUCH, the UE switches the transmit antennas in turn for the consequent uplink transmission in this TTI;
- ◆ Else, the UE shall take the antenna used to transmit the uplink channel in the first timeslot of this TTI as reference and switch the transmit antennas in turn in the consequent uplink timeslots in this TTI. The reference antenna is the other antenna different from the one used last time for this transmission type which may be non-scheduled transmission, semi-persistent transmission and RDI E-PUCH transmission.

Else, the allocated resource for the UE just include one uplink timeslot in one TTI, the UE shall select the antenna according to the different uplink channel.

- ◆ If there is an HS-SICH in this uplink timeslot, the UE shall select the antenna indicated by the parity of HCSN decimal value on the associated HS-SCCH;
- ◆ Else if there is no HS-SICH but scheduled E-PUCH in this uplink timeslot, the UE shall select the antenna indicated by the parity of ECSN decimal value on E-AGCH;
- ◆ Else, the UE shall select the other antenna different from the one used last time for this transmission type which may be non-scheduled transmission, semi-persistent transmission and RDI E-PUCH transmission.

If the standalone midamble channel is configured, the UE antennas time switched transmission procedures for uplink physical channels are described below.

If the UE needs to transmit an HS-SICH, the UE shall use a different antenna from the one used for HS-SICH to transmit the associated standalone midamble channel in the other uplink timeslot of the same subframe configured by higher layers.

If there is other uplink physical channel(s) besides HS-SICH in subframe for the UE to transmit, the standalone midamble channel shall be omitted.

5.12A MU-MIMO operation of HS-DSCH and E-DCH

If the UE is configured in MU-MIMO mode, the Node B should estimates the uplink channels seen from each antenna by uplink physical channels or standalone midamble channel. The Node B scheduler decides whether to schedule multiple UE using the same physical resource in one TTI according to uplink channel estimation.

For the MU-MIMO operation of HS-DSCH, the special default midamble pattern is signaled on HS-SCCH to inform the UE which special default midamble pattern is used. The UE transmits the CQI report and ACK/NACK to the Node B via the associated HS-SICH.

For the MU-MIMO operation of E-DCH, the special default midamble pattern is signaled on E-AGCH to inform the UE which special midamble pattern is used. The Node B transmits ACK/NACK to the each user via the associated E-HICH signature sequence.

5.13 Control Channel Discontinuous reception procedures

If the higher layers set `CONTROL_CHANNEL_DRX_STATUS` to TRUE (as described in [15]) and `Enabling_Delay` is configured to be finite value, after `Enabling_Delay` radio frames have passed, `UE_DRX_Enabled` is TRUE. Or if the higher layers set `CONTROL_CHANNEL_DRX_STATUS` to TRUE and `Enabling_Delay` is configured to be infinity, after the UE has received DRX activation order via HS-SCCH order, `UE_DRX_Enabled` is TRUE. Otherwise `UE_DRX_Enabled` is FALSE.

Whether discontinuous downlink HS-SCCH reception operation or discontinuous downlink E-AGCH reception operation is applied is determined by the setting of `HS_SCCH_DRX_Active` and `E_AGCH_DRX_Active` as follows:

HS_SCCH_DRX_Active shall be set to TRUE while `UE_DRX_Enabled` is TRUE and discontinuous downlink HS-SCCH reception is activated. Otherwise, `HS_SCCH_DRX_Active` shall be set to FALSE.

Discontinuous downlink HS-SCCH reception shall be activated at the time when `UE_DRX_Enabled` is set to TRUE, and may be further deactivated or activated by layer 1 HS-SCCH orders (see section 5.13.2).

E_AGCH_DRX_Active shall be set to TRUE while `UE_DRX_Enabled` is TRUE, E-AGCH DRX information is configured and discontinuous downlink E-AGCH reception is activated. Otherwise, `E_AGCH_DRX_Active` shall be set to FALSE.

Discontinuous downlink E-AGCH reception shall be activated at the time when `UE_DRX_Enabled` is set to TRUE and E-AGCH DRX information is configured and may be further deactivated or activated by layer 1 HS-SCCH orders.

The higher layers define the discontinuous reception procedures using the following parameters (defined in [15]):

HS_SCCH_DRX_Offset: HS-SCCH reception pattern offset in subframes.

E_AGCH_DRX_Offset: E-AGCH reception pattern offset in subframes.

Enabling_Delay: ensures that the HS-SCCHs and E-AGCHs are received continuously for `Enabling_Delay` radio frames after `CONTROL_CHANNEL_DRX_STATUS` is set to TRUE.

HS_SCCH_DRX_cycle: HS-SCCH reception pattern length in subframes.

E_AGCH_DRX_cycle: E-AGCH reception pattern length in subframes.

Inactivity_Threshold_for_HS_SCCH_DRX_cycle: For single carrier HS-DSCH reception, when `HS_SCCH_DRX_Active` is TRUE, this timer shall be started or restarted in the same subframe as the HS-SICH corresponding to an HS-PDSCH reception.

For multi-carrier HS-DSCH reception, this timer should be maintained per UE. When `HS_SCCH_DRX_Active` is TRUE, this timer shall be started or restarted in the same subframe as the HS-SICH on any configured carrier corresponding to an HS-PDSCH reception.

E_AGCH_Inactivity_Monitor_Threshold: For single carrier E-DCH transmission, when `E_AGCH_DRX_Active` is TRUE, this timer shall be started or restarted in the same subframe as the E-HICH which contains the HARQ-ACK corresponding to the latest scheduling information indicating the TEBS equals zero. If the UE is transmitting SI only MAC-e PDU with TEBS equals zero and the UE is monitoring E-AGCHs only in the E-AGCH reception pattern, this timer shall not be started or restarted.

For multi-carrier E-DCH transmission, this timer should be maintained per UE. When `E_AGCH_DRX_Active` is TRUE, this timer shall be started or restarted in the same subframe as the E-HICH on any configured carrier which contains the HARQ-ACK corresponding to the latest scheduling information indicating the TEBS equals zero. If the UE is transmitting SI only MAC-i PDU with TEBS equals zero and the UE is monitoring E-AGCHs only in the E-AGCH reception pattern on all configured carriers, this timer shall not be started or restarted.

5.13.1 Discontinuous downlink reception

The HS-SCCH reception pattern is the same for all the configured carriers of the UE and is derived from a discontinuous reception subframe numbering as follows.

The HS-SCCH reception pattern is the set of subframes whose HS-SCCH discontinuous reception radio frame number CFN and subframe number subframe number verify:

$$((2 * \text{CFN} - \text{HS_SCCH_DRX Offset} + \text{subframe number}) \bmod \text{HS_SCCH_DRX cycle}) = 0$$

For the first subframe within each radio frame, the subframe number shall be set to 0. For the second subframe within each radio frame, the subframe number shall be set to 1.

When HS_SCCH_DRX_Active is FALSE, the UE shall monitor HS-SCCHs continuously according to rules defined in the subclause 5.9.3.

When HS_SCCH_DRX_Active is TRUE and the timer Inactivity Threshold for HS-SCCH DRX cycle is not configured by higher layers, the UE shall monitor the HS-SCCH subframes in the HS-SCCH reception pattern on all configured carriers.

When HS_SCCH_DRX_Active is TRUE and the timer Inactivity Threshold for HS-SCCH DRX cycle is configured by higher layers, the UE is required to monitor the HS-SCCHs in the UE's HS-SCCH set on all configured carriers continuously when the timer is running. The UE shall only monitor the HS-SCCH subframes in the HS-SCCH reception pattern on all configured carriers when the timer is expired.

The E-AGCH reception pattern is the same for all the configured carriers of the UE and is the set of subframes whose E-AGCH discontinuous reception radio frame number CFN and subframe number verify:

$$((2 * \text{CFN} - \text{E_AGCH_DRX Offset} + \text{subframe number}) \bmod \text{E_AGCH_DRX cycle}) = 0$$

When E_AGCH_DRX_Active is FALSE and E-AGCH DRX information is configured, UE shall monitor E-AGCHs continuously.

When E_AGCH_DRX_Active is FALSE and the E-AGCH DRX information is not configured, UE shall monitor E-AGCHs according to rules defined in the subclause 5.11.3.

When E_AGCH_DRX_Active is TRUE and TEBS is larger than zero, the UE shall monitor the E-AGCHs on all configured carriers continuously.

When E_AGCH_DRX_Active is TRUE and TEBS is equal to zero, the UE is required to monitor the E-AGCHs in the UE's E-AGCH set on all configured carriers continuously until the subframe when the timer E_AGCH_Inactivity_Monitor_Threshold is expired. The UE shall start to monitor the E-AGCH subframes in the E-AGCH reception pattern on all configured carriers from the next subframe when the timer is expired.

The HS-SCCH reception pattern is illustrated by Figure 11B. The grey subframes correspond to the HS-SCCH reception pattern HS_SCCH_DRX cycle = 4.

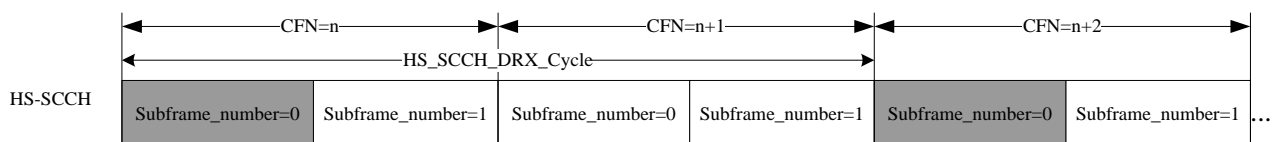

Figure 11B: Example for HS-SCCH reception pattern

5.13.2 HS-SCCH orders

The Node B may activate and deactivate the discontinuous downlink reception operation through physical layer commands transmitted on one of the HS-SCCHs in the HS-SCCH set as specified in [9]. The activation and deactivation of the discontinuous downlink reception operation is applied by the UE in the same subframe as the HS-SICH subframe which contains the HARQ-ACK corresponding to the order. For multi-carrier E-DCH transmission and multi-carrier HS-DSCH reception, the activation and deactivation of the discontinuous downlink reception operation applies to HS-SCCH and E-AGCH on all carriers, namely, when receiving a DRX activation order on HS-SCCH, the UE shall

activate the DRX of HS-SCCH and E-AGCH on all carriers; when receiving a DRX deactivation order on HS-SCCH, the UE shall deactivate the DRX of HS-SCCH and E-AGCH on all carriers.

6 Physical layer procedures for the 7.68 Mcps option

6.1 Transmitter Power Control

The transmit power control procedure is identical to that of the 3.84Mcps TDD option [clause 4.2] with the exception that the tabulated α_e values of subclause 4.2.2.4.1 for uplink power control of E-PUCH are substituted with the following values of table 3.

Table 3: Tabulated α_e values for the 7.68Mcps option

SF_{E-PUCH}	α_e (dB)
1	15
2	12
4	9
8	6
16	3
32	0

6.2 Timing Advance

UTRAN may adjust the UE transmission timing with timing advance. The initial value for timing advance (TA_{phys}) will be determined in the UTRAN by measurement of the timing of the PRACH or E-RUCCH. The required timing advance will be represented as a 9 bit number (0-511) 'UL Timing Advance' TA_{ul} , being the multiplier of 4 chips which is nearest to the required timing advance (i.e. $TA_{phys} = TA_{ul} \times 4$ chips).

When Timing Advance is used the UTRAN will continuously measure the timing of a transmission from the UE and send the necessary timing advance value. On receipt of this value the UE shall adjust the timing of its transmissions accordingly in steps of ± 4 chips. The transmission of TA values is done by means of higher layer messages. Upon receiving the TA command the UE shall adjust its transmission timing according to the timing advance command at the frame number specified by higher layer signaling. The UE is signaled the TA value in advance of the specified frame activation time to allow for local processing of the command and application of the TA adjustment on the specified frame. Node-B is also signaled the TA value and radio frame number that the TA adjustment is expected to take place.

If TA is enabled by higher layers, after handover the UE shall transmit in the new cell with timing advance TA adjusted by the relative timing difference Δt between the new and the old cell:

$$TA_{new} = TA_{old} + 2\Delta t.$$

6.3 Synchronisation procedures

The synchronisation procedures are identical to those of the 3.84Mcps TDD option [clause 4.4].

6.4 Discontinuous transmission (DTX) procedure

The discontinuous transmission procedure is identical to that of the 3.84Mcps TDD option [clause 4.5].

6.5 Downlink Transmit Diversity

Downlink transmit diversity for PDSCH, DPCH, P-CCPCH, S-CCPCH, PICH, MICH, HS-SCCH, HS-PDSCH, E-AGCH, E-HICH and SCH is optional in UTRAN. Its support is mandatory at the UE.

6.5.1 Transmit Diversity for PDSCH, DPCH, HS-SCCH, HS-PDSCH and E-AGCH

Transmit diversity for PDSCH, DPCH, HS-SCCH, HS-PDSCH and E-AGCH is identical to the 3.84Mcps TDD option [clause 4.6.1].

6.5.2 Transmit Diversity for SCH and S-CCPCH

Transmit diversity for SCH and S-CCPCH is identical to the 3.84Mcps TDD option [clause 4.6.2].

6.5.3 Transmit Diversity for Beacon Channels

When beacon channels use burst type 4, SCTD shall not be applied.

When beacon channels use burst type 1, Space Code Transmit Diversity (SCTD) for beacon channels may be employed optionally in the UTRAN. The support is mandatory in the UE except for the case where the UE only supports burst type 4. The use of SCTD will be indicated by higher layers. If SCTD is active within a cell:

- SCTD shall be applied to any beacon channel, and
- the maximum number K_{Cell} of midambles for burst type 1 that are supported in this cell may be 8 or 16, see [8]. The case of $K_{\text{Cell}} = 4$ midambles is not allowed for this burst type.

6.5.3.1 SCTD Transmission Scheme

The open loop downlink transmit diversity scheme for beacon channels is shown in figure 12. Channel coding, rate matching, interleaving and bit-to-symbol mapping are performed as in the non-diversity mode. In Space Code Transmit Diversity mode the data sequence is spread with the channelisation codes $c_{32}^{(k=1)}$ and $c_{32}^{(k=2)}$ and scrambled with the cell specific scrambling code. The spread sequence on code $c_{32}^{(k=2)}$ is then transmitted on the diversity antenna. The power applied to each antenna shall be equal.

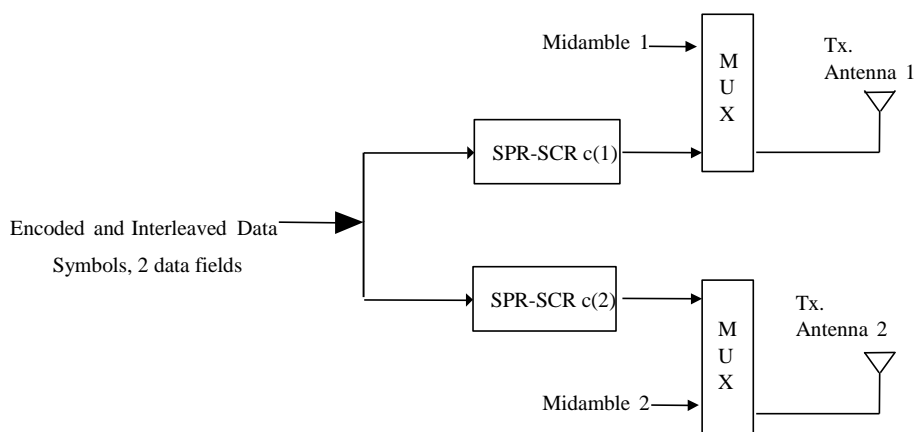

Figure 12: Block Diagram of the transmitter SCTD

6.6 Random access procedure

The physical random access procedure described below is invoked whenever a higher layer requests transmission of a message on the RACH. The physical random access procedure is controlled by primitives from RRC and MAC.

Retransmission on the RACH in case of failed transmission (e.g. due to a collision) is controlled by higher layers. Thus, the backoff algorithm and associated handling of timers is not described here. The definition of the RACH in terms of PRACH Access Service Classes is broadcast on the BCH in each cell. Parameters for common physical channel uplink outer loop power control are also broadcast on the BCH in each cell. The UE needs to decode this information prior to transmission on the RACH.

6.6.1 Physical random access procedure

The physical random access procedure is identical to that of the 3.84Mcps TDD option [clause 4.7.1].

6.6A E-RUCCH transmission procedure

The E-RUCCH transmission procedure is identical to that of the 3.84Mcps TDD option [clause 4.7A].

6.7 DSCH procedure

Higher layer signalling is used to indicate to the UE the need for PDSCH detection.

6.8 Idle periods for IPDL location method

The IPDL procedure is identical to that of the 3.84Mcps TDD option [clause 4.10].

6.9 HS-DSCH Procedure

6.9.1 Link Adaptation Procedure

For HS-DSCH, the modulation scheme and effective code rate shall be selected by higher layers located within the NodeB. This shall be achieved by appropriate selection of an HS-DSCH transport block size, modulation format and resources by higher layers. Selection of these parameters may be based on CQI reports from the UE.

The overall HS-DSCH link adaptation procedure consists of *two parts*:

Node B procedure:

- 1) The NodeB shall transmit HS-SCCH carrying a UE identity identifying the UE for which HS-DSCH TTI allocation has been given. In the case of HS-DSCH transmissions in consecutive TTIs to the same UE, the same HS-SCCH shall be used for associated signalling.
- 2) The NodeB transmits HS-DSCH to the UE using the resources indicated in the HS-SCCH.
- 3) Upon receiving the HS-SICH from the respective UE, the status report (ACK/NACK and CQI) shall be passed to higher layers.

UE procedure:

- 1) When indicated by higher layers, the UE shall start monitoring all HS-SCCHs that are in its HS-SCCH set as signalled to it by higher layers. The information carried on the HS-SCCH is described in [8].
- 2) In the case that a HS-SCCH is identified to be correct by its CRC, the UE shall read the HS-PDSCHs indicated by the HS-SCCH. In the case that a HS-SCCH is identified to be incorrect, the UE shall discard the data on the HS-SCCH and return to monitoring.
- 3) After reading the HS-PDSCHs, the UE shall generate an ACK/NACK message and transmit this to the NodeB in the associated HS-SICH, along with the most recently derived CQI.

The mapping of HS-PDSCH channelisation code set and timeslot information carried by the HS-SCCH for a given HS-DSCH TTI is described in [9].

For a given allocation of HS-PDSCH resources to a UE for a specific HS-DSCH TTI, the following shall apply:

- If timeslot information on HS-SCCH indicates two or more timeslots, none of these timeslots shall comprise a beacon channel.
- If timeslot information on HS-SCCH indicates a single timeslot and this timeslot comprises a beacon channel then:
 - The Node-B shall not indicate SF=1 for any HS-PDSCH resource.
 - The set of HS-PDSCH resources allocated by the Node-B to a UE shall exclusively comprise either beacon function or non-beacon function physical channels. The Node B shall therefore not allocate both beacon function and non-beacon function physical channels within the beacon timeslot to the UE. If the HS-DSCH for a specific HS-DSCH TTI is mapped to the beacon channel, this shall be signalled using $k_{start} = 1$ and $k_{stop} = 1$. For a definition of the first and last allocated channelisation code indices k_{start} and k_{stop} on HS-SCCH refer to [9].
 - When SCTD antenna diversity is applied to the beacon channel, then the presence of channelisation code $c_{32}^{(k=1)}$ within the channelisation code set information on HS-SCCH shall implicitly indicate the presence of channelisation code $c_{32}^{(k=2)}$.

6.9.2 HS-DSCH Channel Quality Indication Procedure

The HS-DSCH channel quality indication procedure is identical to that of the 3.84Mcps TDD option [clause 4.11.2].

6.10 Macro-diversity procedure

The macrodiversity procedure is identical to that of the 3.84Mcps TDD option [clause 4.12].

6.11 E-DCH related procedures

6.11.1 ACK/NACK detection

The procedure for detection of ACK/NACK is identical to that of the 3.84Mcps option [subclause 4.13.1]

6.11.2 Serving and neighbour cell pathloss metric derivation

The procedure for serving and neighbour cell metric derivation is identical to that of the 3.84Mcps option [subclause 4.13.2]

6.11.3 Channelisation code hopping procedure for E-PUCH

For the 7.68Mcps option, the procedure for channelisation code hopping on E-PUCH is identical to that of the 3.84Mcps option [subclause 4.13.3] with two exceptions:

- i) the code hopping index parameter is calculated as: $h_i = (t_i + CFN) \bmod 32$
- ii) the code hopping index parameter sequences of table 1c are substituted for the values of table 4 below.

Table 4: Hopping index parameter sequences for the 7.68Mcps options

C_{alloc} CRRI		Hop index h_i																															
		0	1	2	3	4	5	6	7	8	9	10	11	12	13	14	15	16	17	18	19	20	21	22	23	24	25	26	27	28	29	30	31
SF32	31	1	17	9	25	5	21	13	29	3	19	11	27	7	23	15	31	2	18	10	26	6	22	14	30	4	20	12	28	8	24	16	32
	32	2	18	10	26	6	22	14	30	4	20	12	28	8	24	16	32	1	17	9	25	5	21	13	29	3	19	11	27	7	23	15	31
	33	3	19	11	27	7	23	15	31	1	17	9	25	5	21	13	29	4	20	12	28	8	24	16	32	2	18	10	26	6	22	14	30
	34	4	20	12	28	8	24	16	32	2	18	10	26	6	22	14	30	3	19	11	27	7	23	15	31	1	17	9	25	5	21	13	29

1 1 1 2 1 2 1 2 1 2 1 2 1 2 1 2 1 2 1 2 1 2 1 2 1 2 1 2 1 2
2 2 2 1 2 1 2 1 2 1 2 1 2 1 2 1 2 1 2 1 2 1 2 1 2 1 2 1 2 1

SF1
1 0 1

Annex A (informative): Power Control

A.1 Example Implementation of Downlink Power Control in the UE

The power control may be realized by two cascaded control loops. The outer loop controls the transmission quality, whose reference value is set by higher layers [15], by providing the reference value for the inner loop. This reference value should be the SIR at the UE [15]. The inner loop controls the physical quantity for which the outer loop produces the reference value (e. g. the SIR) by generating TPC commands. This may be done by comparing the measured SIR to its reference value. When the measured value is higher than the target SIR value, TPC command = "down". When this is lower than or equal to the target SIR value, TPC command = "up".

In case of a downlink transmission pause on the DPCH or PDSCH, the receive power (RSCP) of the data can no longer be used for inner loop SIR calculations in the UE. In this case the UE should trace the fluctuations of the pathloss based on the P-CCPCH and use these values instead for generating the TPC commands. This pathloss together with the timeslot ISCP measurement in the data timeslot, which is ongoing, should be used to calculate a virtual SIR value:

$$SIR_{virt}(i) = RSCP_{virt}(i) - ISCP(i) + 10 \lg SF ,$$

$$RSCP_{virt}(i) = RSCP_0 + L_0 - L(i) + \sum_{k=1}^{i-1} TPC(k) ,$$

RSCP:	Received signal code power in dBm
ISCP:	Interference signal code power in the DPCH / PDSCH timeslot in dBm
SF:	Used spreading factor
L:	pathloss in dB measured on the P-CCPCH. The same weighting of the long- and short-term pathloss should be used as for uplink open loop power control, see Annex A.1
i:	index for the frames during a transmission pause, $1 \leq i \leq$ number of frames in the pause
L_0 :	weighted pathloss in the last frame before the transmission pause in dB
$RSCP_0$:	RSCP of the data that was used in the SIR calculation of the last frame before the pause in dBm
TPC (k):	\pm power control stepsize in dB according to the TPC bit generated and transmitted in frame k, TPC bit "up" = +stepsize, TPC bit "down" = -stepsize

A.2 Example Implementation of Closed Loop Uplink Power Control in Node B for 1.28Mcps TDD

Uplink power control is based on a quality target, set by higher layers. An example implementation for a Node B TPC calculation algorithm is SIR based. In this algorithm, an outer loop sets a target SIR value, SIR_{target} , which may be adjusted from time to time in order to ensure that the quality target is met. In the meantime, as part of an inner loop a calculation of SIR in associated uplink transmissions may be carried out. When the measured value is higher than the target SIR value, TPC command = "down". When the measurement is lower than or equal to the target SIR, TPC command = "up".

A.3 Example Implementation of Downlink Power Control in UE for 1.28Mcps TDD when TSTD is used

Downlink power control is based on a quality target, set by higher layers. An example implementation for a UETPC calculation algorithm is SIR based. In this algorithm, an outer loop sets a target SIR value, SIR_{target} , which may be adjusted from time to time in order to ensure that the quality target is met. In the meantime, as part of an inner loop a

calculation of SIR in associated downlink transmissions may be carried out. When the measured value is higher than the target SIR value, TPC command = "down". When the measurement is lower than or equal to the target SIR, TPC command = "up".

When TSTD is applied, the UE can use the consecutive measurements of SIR to calculate SIR_{AVG} :

$$SIR_{AVG}(i) = w_1 SIR(i-1) + w_2 SIR(i),$$

where, $w_1 + w_2 = 1$, $w_1 \geq 0$, $w_2 \geq 0$, and $SIR(i)$ is the measurement of SIR in sub-frame i and $SIR_{AVG}(i)$ is the measurement of SIR_{AVG} in sub-frame i . If SIR_{AVG} is greater than the target SIR value, TPC command = "down". If the SIR_{AVG} is smaller than the target SIR value, TPC command = "up".

In case of a downlink transmission pause on the DPCH, the example in Annex A.1 can be used for DL power control with $RSCP_{virt}(i)$ and $ISCP(i)$ replaced by $RSCP_{AVG}(i)$ and $ISCP_{AVG}(i)$, where

$$RSCP_{AVG}(i) = w_1 RSCP_{virt}(i-1) + w_2 RSCP_{virt}(i),$$

$$ISCP_{AVG}(i) = w_1 ISCP(i-1) + w_2 ISCP(i).$$

A.4 Example Implementation of open Loop Power Control for access procedure for 1.28Mcps TDD

The higher layer signals (on BCH) a power increment that is applied to the SYNC-UL burst only for the access procedure. At each new transmission of a SYNC-UL burst during the access procedure, the transmit power level can be increased by this power increment.

A.5 Example Implementation of Closed Loop Uplink HS-SICH Power Control in Node B for 1.28Mcps TDD

If the UE is not configured in MIMO mode, uplink power control is based on a quality target and a power offset, set by higher layers. An example implementation for a Node B TPC calculation algorithm is SIR based (HS-SICH SIR Target). In this algorithm, if an ACK is decoded from HS-SICH, the Node B shall adjust the measured value of HS-SICH with a power offset. When the (adjusted) measured value is higher than the target SIR value, TPC command = "down". When the (adjusted) measurement is lower than or equal to the target SIR, TPC command = "up".

If the UE is configured in MIMO mode, uplink power control is based on a quality target and a power offset, set by higher layers. An example implementation for a Node B TPC calculation algorithm is SIR based (HS-SICH SIR Target). In this algorithm, if an ACK is decoded from HS-SICH for single stream transmission or two ACKs are decoded from HS-SICH for dual stream transmission, the Node B shall adjust the measured value of HS-SICH with a power offset. When the (adjusted) measured value is higher than the target SIR value, TPC command = "down". When the (adjusted) measurement is lower than or equal to the target SIR, TPC command = "up".

Annex B (informative): Determination of Weight Information

Selective Transmit Diversity (STD) and Transmit Adaptive Antennas (TxAA) are examples of transmit diversity schemes for dedicated physical channels.

B.1 STD Weights

The weight vector will take only two values depending on the signal strength received by each antenna in the uplink slot. For each user, the antenna receiving the highest power will be selected (i.e. the corresponding weight will be set to 1).

Table B.1: STD weights for two TX antennas

	W_1	W_2
Antenna 1 receiving highest power	1	0
Antenna 2 receiving highest power	0	1

B.2 TxAA Weights

In a generic sense, the weight vector to be applied at the transmitter is the \underline{w} that maximises:

$$P = \underline{w}^H \mathbf{H}^H \mathbf{H} \underline{w} \quad (1)$$

where

$$\mathbf{H} = [\underline{h}_1 \quad \underline{h}_2] \text{ and } \underline{w} = [w_1, w_2]^T$$

and where the column vector \underline{h}_i represents the estimated uplink channel impulse response for the i 'th transmission antenna, of length equal to the length of the channel impulse response.

Annex C (informative): Cell search procedure for 3.84Mcps TDD

During the cell search, the UE searches for a cell and determines the downlink scrambling code, basic midamble code and frame synchronisation of that cell. The cell search is typically carried out in three steps:

Step 1: Primary synchronisation code acquisition

During the first step of the cell search procedure, the UE uses the SCH's primary synchronisation code to find a cell. This is typically done with a single matched filter (or any similar device) matched to the primary synchronisation code which is common to all cells. A cell can be found by detecting peaks in the matched filter output.

Note that for a cell of SCH slot configuration case 1, the SCH can be received periodically every 15 slots. In case of a cell of SCH slot configuration case 2, the following SCH slot can be received at offsets of either 7 or 8 slots from the previous SCH slot.

Step 2: Code group identification and slot synchronisation

During the second step of the cell search procedure, the UE uses the SCH's secondary synchronisation codes to identify 1 out of 32 code groups for the cell found in the first step. This is typically done by correlating the received signal with the secondary synchronisation codes at the detected peak positions of the first step. The primary synchronisation code provides the phase reference for coherent detection of the secondary synchronisation codes. The code group can then uniquely be identified by detection of the maximum correlation values.

Each code group indicates a different t_{offset} parameter and 4 specific cell parameters. Each of the cell parameters is associated with one particular downlink scrambling code and one particular long and short basic midamble code. When the UE has determined the code group, it can unambiguously derive the slot timing of the found cell from the detected peak position in the first step and the t_{offset} parameter of the found code group in the second step.

Note that the modulation of the secondary synchronisation codes also indicates the position of the SCH slot within a 2 frames period, e.g. a frame with even or odd SFN. Additionally, in the case of SCH slot configuration following case 2, the SCH slot position within one frame, e.g. first or last SCH slot, can be derived from the modulation of the secondary synchronisation codes.

Step 3: Downlink scrambling code, basic midamble code identification and frame synchronisation

During the third and last step of the cell search procedure, the UE determines the exact downlink scrambling code, basic midamble code and frame timing used by the found cell. The long basic midamble code can be identified by correlation over the P-CCPCH (or any other beacon channel) with the 4 possible long basic midamble codes of the code group found in the second step. A P-CCPCH (or any other beacon channel) always uses the midamble $m^{(1)}$ (and in case of SCTD also midamble $m^{(2)}$) derived from the long basic midamble code and always uses a fixed and pre-assigned channelisation code.

When the long basic midamble code has been identified, downlink scrambling code and cell parameter are also known. The UE can read system and cell specific BCH information and acquire frame synchronisation.

Note that even for an initial cell parameter assignment, a cell cycles through a set composed of 2 different cell parameters according to the SFN of a frame, e.g. the downlink scrambling code and the basic midamble code of a cell alternate for frames with even and odd SFN. Cell parameter cycling leaves the code group of a cell unchanged.

If the UE has received information about which cell parameters or SCH configurations to search for, cell search can be simplified.

Annex CA (informative): Cell search procedure for 1.28Mcps TDD

During the initial cell search, the UE searches for a cell. It then determines the DwPTS synchronization, scrambling and basic midamble code identification, control multi-frame synchronisation and then reads the contents in BCH. This initial cell search is carried out in 4 steps:

Step 1: Search for DwPTS

During the first step of the initial cell search procedure, the UE uses the SYNC-DL (in DwPTS) to acquire DwPTS synchronization to a cell. This is typically done with one or more matched filters (or any similar device) matched to the received SYNC-DL which is chosen from PN sequences set. A single or more matched filter (or any similar device) is used for this purpose. During this procedure, the UE needs to identify which of the 32 possible SYNC-DL sequences is used.

Step 2: Scrambling and basic midamble code identification

During the second step of the initial cell search procedure, the UE receives the midamble of the P-CCPCH. The P-CCPCH is followed by the DwPTS. In the 1.28 Mcps TDD each DwPTS code corresponds to a group of 4 different basic midamble code. Therefore there are total 128 midamble codes and these codes are not overlapping with each other. Basic midamble code number divided by 4 gives the SYNC-DL code number. Since the SYNC-DL and the group of basic midamble codes of the P-CCPCH are related one by one (i.e., once the SYNC-DL is detected, the 4 midamble codes can be determined), the UE knows which 4 basic midamble codes are used. Then the UE can determine the used basic midamble code using a try and error technique. The same basic midamble code will be used throughout the frame. As each basic midamble code is associated with a scrambling code, the scrambling code is also known by that time. According to the result of the search for the right midamble code, UE may go to next step or go back to step 1.

Step 3: Control multi-frame synchronisation

During the third step of the initial cell search procedure, the UE searches for the MIB (Master Indication Block) of multi-frame of the BCH in the P-CCPCH indicated by QPSK phase modulation of the DwPTS with respect to the P-CCPCH midamble. The control multi-frame is positioned by a sequence of QPSK symbols modulated on the DwPTS. [n] consecutive DwPTS are sufficient for detecting the current position in the control multi-frame. According to the result of the control multi-frame synchronisation for the right midamble code, UE may go to next step or go back to step 2.

Step 4: Read the BCH

The (complete) broadcast information of the found cell in one or several BCHs is read. According to the result the UE may move back to previous steps or the initial cell search is finished.

For Dedicated Carrier MBSFN

For the MS burst, the preamble codes (see the Table AA.1a in TS25.221) are segmented into even code group and odd code group, $P_{P,even}$ group and $P_{P,odd}$ group (see the clause 8.3Aa in TS25.223). When the preamble of the MS burst is $P_{P,odd}$, it indicates that the next sub-frame is the beginning of the multi-frame of PCCPCH; otherwise, the preamble of MS burst uses the $P_{P,even}$ ($P_{P,even}$ and $P_{P,odd}$ belong to the same subgroup). The preamble of MT burst is decided by the upper-layer signaling. This initial SFN cell search is carried out in 4 steps:

Step 1: Search for $P_{P,even}$

During the first step of the initial SFN cell search procedure, the UE uses the $P_{P,even}$ (in MS burst) to acquire synchronization to a SFN cell.

Step 2: Multi-frame synchronization

During the second step of the initial SFN cell search procedure, the UE searches for the $P_{P,odd}$ (in MS burst) to get the beginning position of the multi-frame of PCCPCH. According to the result of multi-frame synchronization, UE may go to next step or go back to step 1.

Step 3: Read the BCCH

The UE reads the MIB (Master Indication Block) of multi-frame P-CCPCHs in the BCH and gets the system information of the found SFN cell. According to the result of reading the BCCH, UE may go to next step or go back to step 2.

Step 4: Read the MCCH

The UE reads the MCCH indicated by the BCCH information. According to the result the UE may move back to previous steps or the initial cell search is finished.

Annex CB (informative): Examples random access procedure for 1.28Mcps TDD

Table CB.1: One PRACH, TTI=5ms, WT=4, L =1, SF4 PRACH

Sub-frame Number	0	1	2	3	4	5	6	7	8	9	10
Users sending on UpPCH	1	3	5	7							
	2	4	6	8							
Acknowledged user on FPACH		1	2	3	4	5	6	7			
User sending on PRACH 0				1	2	3	4	5	6	7	

User 8 is not granted because more than 5 sub-frames would have passed since the UpPCH.

Table CB.2: Two PRACHs, TTI=10ms, WT=4, L =2, SF8 PRACH

Sub-frame Number	0	1	2	3	4	5	6	7	8	9	10	11
Users sending on UpPCH	1	3	5	7								
	2	4	6	8								
Acknowledged user on FPACH		1	2	3	4	5	6	7				
User sending on PRACH 0					2	2	4	4	6	6		
User sending on PRACH 1					1	1	3	3	5	5	7	7

User 8 is not granted because more than 5 sub-frames would have passed since the UpPCH.

Table CB.3: Four PRACHs, TTI=20ms, WT=4, L =4, SF16 PRACH

Sub-frame Number	0	1	2	3	4	5	6	7	8	9	10	11	12	13
Users sending on UpPCH	1	3	5	7										
	2	4	6	8										
Acknowledged user on FPACH		1	2	3	4	5	6	7						
User sending on PRACH 0							4	4	4	4				
User sending on PRACH 1					1	1	1	1	5	5	5	5		
User sending on PRACH 2					2	2	2	2	6	6	6	6		
User sending on PRACH 3							3	3	3	3	7	7	7	7

User 8 is not granted because more than 5 sub-frames would have passed since the UpPCH.

Table CB.4: Two PRACHs, TTI=20ms, WT=4, L =4, SF16 PRACH

Sub-frame Number	0	1	2	3	4	5	6	7	8	9	10	11	12
Users sending on UpPCH	1	3	5	7									
	2	4	6	8									
Acknowledged user on FPACH	X	1			2	3			X	X			
User sending on PRACH 0							2	2	2	2			
User sending on PRACH 1					1	1	1	1	3	3	3	3	

The FPACH is used ONLY in sub-frames 0, 1, 4, 5, 8, 9,... because they correspond to the used RACH resources.

The FPACH in sub-frame 0 is not used because no UpPCH is preceding.

The FPACH in sub-frames 8,9 is not used because no UpPCH is preceding in the last 4 sub-frames.

In contrast to the previous examples users 4,5,6,7 are not granted because they would not lead to a RACH anyway. In this example their grant would come too late.

User 8 is not granted because more than 4 sub-frames would have passed since the UpPCH.

Annex D (informative): Change history

Change history							
Date	TSG #	TSG Doc.	CR	Rev	Subject/Comment	Old	New
14/01/00	RAN_05	RP-99594	-	-	Approved at TSG RAN #5 and placed under Change Control	-	3.0.0
14/01/00	RAN_06	RP-99698	001	01	Primary and Secondary CCPCH in TDD	3.0.0	3.1.0
14/01/00	RAN_06	RP-99698	002	-	Measurement procedure of received reference power for OL-TPC in TDD	3.0.0	3.1.0
14/01/00	RAN_06	RP-99699	004	1	STTD capability for P-CCPCH, TDD component	3.0.0	3.1.0
14/01/00	RAN_06	RP-99697	005	1	Alignment of Terminology Regarding Spreading for TDD Mode	3.0.0	3.1.0
14/01/00	-	-	-	-	Change history was added by the editor	3.1.0	3.1.1
31/03/00	RAN_07	RP-000070	003	2	Cycling of cell parameters	3.1.1	3.2.0
31/03/00	RAN_07	RP-000070	007	2	Clarifications on the UL synchronisation and Timing advance	3.1.1	3.2.0
31/03/00	RAN_07	RP-000070	008	-	Modification of SIR threshold on setting TPC	3.1.1	3.2.0
31/03/00	RAN_07	RP-000070	009	1	New section describing the random access procedure	3.1.1	3.2.0
31/03/00	RAN_07	RP-000070	011	-	Removal of Synchronisation Case 3 in TDD	3.1.1	3.2.0
31/03/00	RAN_07	RP-000070	012	1	Clarifications on power control procedures	3.1.1	3.2.0
31/03/00	RAN_07	RP-000070	013	-	Signal Point Constellation	3.1.1	3.2.0
31/03/00	RAN_07	RP-000070	014	2	Out-of-sync handling for UTRA TDD	3.1.1	3.2.0
31/03/00	RAN_07	RP-000070	015	-	Removal of ODMA from the TDD specifications	3.1.1	3.2.0
26/06/00	RAN_08	RP-000274	016	-	Editorial correction for the power control section in 25.224	3.2.0	3.3.0
26/06/00	RAN_08	RP-000274	017	-	Power control for TDD during DTX	3.2.0	3.3.0
26/06/00	RAN_08	RP-000274	018	1	Power Control for PDSCH	3.2.0	3.3.0
26/06/00	RAN_08	RP-000274	020	1	Editorial modification of 25.224	3.2.0	3.3.0
26/06/00	RAN_08	RP-000274	021	-	Clarifications on Tx Diversity for UTRA TDD	3.2.0	3.3.0
26/06/00	RAN_08	RP-000274	022	1	Introduction of the TDD DSCH detection procedure in TS 25.224	3.2.0	3.3.0
26/06/00	RAN_08	RP-000274	023	-	Downlink power control on timeslot basis	3.2.0	3.3.0
23/09/00	RAN_09	RP-000347	019	1	Gain Factors for TDD Mode	3.3.0	3.4.0
23/09/00	RAN_09	RP-000347	025	-	Terminology regarding the beacon function	3.3.0	3.4.0
23/09/00	RAN_09	RP-000347	026	1	Synchronisation of timing advance adjustment and timing deviation measurement	3.3.0	3.4.0
23/09/00	RAN_09	RP-000347	027	1	CCTrCH UL/DL pairing for DL inner loop power control	3.3.0	3.4.0
23/09/00	RAN_09	RP-000347	028	1	RACH timing in TDD mode	3.3.0	3.4.0
23/09/00	RAN_09	RP-000347	030	1	TDD Access Bursts for HOV	3.3.0	3.4.0
23/09/00	RAN_09	RP-000347	032	-	Removal of ODMA related abbreviations and correction of references	3.3.0	3.4.0
23/09/00	RAN_09	RP-000347	033	-	Clarifications on the Out-of-sync handling for UTRA TDD	3.3.0	3.4.0
15/12/00	RAN_10	RP-000544	035	1	Radio Link establishment and sync status reporting	3.4.0	3.5.0
15/12/00	RAN_10	RP-000544	040	-	Clarification on PICH power setting	3.4.0	3.5.0
15/12/00	RAN_10	RP-000544	042	-	Correction to TDD timing advance description	3.4.0	3.5.0
15/12/00	RAN_10	RP-000544	043	-	Limit on maximum value of alpha used for open loop power control	3.4.0	3.5.0
16/03/01	RAN_11	-	-	-	Approved as Release 4 specification (v4.0.0) at TSG RAN #11	3.5.0	4.0.0
16/03/01	RAN_11	RP-010065	036	-	DTX and Special Burst Scheduling	3.5.0	4.0.0
16/03/01	RAN_11	RP-010065	037	1	RACH random access procedure	3.5.0	4.0.0
16/03/01	RAN_11	RP-010065	045	-	Introduction of closed-loop Tx diversity for the PDSCH and DTX for the PUSCH/PDSCH	3.5.0	4.0.0
16/03/01	RAN_11	RP-010065	046	2	Corrections of TDD power control sections	3.5.0	4.0.0
16/03/01	RAN_11	RP-010065	050	-	Use of a special burst in reconfiguration	3.5.0	4.0.0
16/03/01	RAN_11	RP-010065	053	-	Known TFCI for the TDD special burst	3.5.0	4.0.0
16/03/01	RAN_11	RP-010073	044	2	Layer 1 procedure for Node B synchronisation	3.5.0	4.0.0
16/03/01	RAN_11	RP-010071	047	1	Inclusion of 1,28 Mcps TDD in TS 25.224	3.5.0	4.0.0
16/03/01	RAN_11	RP-010072	048	1	Idle periods for IPDL location method	3.5.0	4.0.0
15/06/01	RAN_12	RP-010338	057	-	Correction of Timing Advance section for 3.84 Mcps TDD	4.0.0	4.1.0
15/06/01	RAN_12	RP-010338	059	-	Addition to the abbreviation list	4.0.0	4.1.0
15/06/01	RAN_12	RP-010343	049	-	Clarification of IP_Frame(x) definition	4.0.0	4.1.0
15/06/01	RAN_12	RP-010343	055	1	Correction of IPDL burst parameters	4.0.0	4.1.0
21/09/01	RAN_13	RP-010525	064	1	Correction of criteria for OOS indication	4.1.0	4.2.0
21/09/01	RAN_13	RP-010531	060	-	Corrections for TS 25.224	4.1.0	4.2.0
21/09/01	RAN_13	RP-010531	062	1	Corrections of Annex E in 25.224	4.1.0	4.2.0
21/09/01	RAN_13	RP-010531	061	-	Corrections and Clarifications for calculation of idle period position in subclause 4.10.3 in 25.224	4.1.0	4.2.0
14/12/01	RAN_14	RP-010742	066	-	Removal of the remark on power control	4.2.0	4.3.0
14/12/01	RAN_14	RP-010742	068	1	Transmit Diversity for P-CCPCH and PICH	4.2.0	4.3.0
14/12/01	RAN_14	RP-010742	070	1	Correction to random access procedure (Primitive from MAC)	4.2.0	4.3.0
14/12/01	RAN_14	RP-010749	073	1	Random access procedure for 1.28Mcps TDD	4.2.0	4.3.0
14/12/01	RAN_14	RP-010749	074	-	Transmit diversity for P-CCPCH and PICH	4.2.0	4.3.0
14/12/01	RAN_14	RP-010749	075	-	Correction of Annex A.3 in 25.224	4.2.0	4.3.0
14/12/01	RAN_14	RP-010749	076	-	Removal of the remark on power control	4.2.0	4.3.0

Change history							
Date	TSG #	TSG Doc.	CR	Rev	Subject/Comment	Old	New
14/12/01	RAN_14	RP-010749	077	-	Corrections to DL-PC sections for 1.28 Mcps TDD	4.2.0	4.3.0
08/03/02	RAN_15	RP-020052	079	1	Removal of quantisation of bj gain factor when calculated from a reference TFC	4.3.0	4.4.0
08/03/02	RAN_15	RP-020052	084	1	TDD MAC layer subchannel assignment	4.3.0	4.4.0
08/03/02	RAN_15	RP-020052	086	-	Transmit diversity on PICH	4.3.0	4.4.0
08/03/02	RAN_15	RP-020057	080	-	Introduction of "UE Positioning Enhancements for 1.28 Mcps TDD"	4.3.0	5.0.0
08/03/02	RAN_15	RP-020055	082	1	Introduction of "Node B synchronization for 1.28 Mcps TDD"	4.3.0	5.0.0
08/03/02	RAN_15	RP-020058	081	1	Power Control and Procedures for HSDPA	4.3.0	5.0.0
07/06/02	RAN_16	RP-020315	088	-	Clarification on power control and Tx Diversity procedure for 1.28 Mcps TDD	5.0.0	5.1.0
07/06/02	RAN_16	RP-020317	089	-	TxDiversity for HSDPA in TDD	5.0.0	5.1.0
07/06/02	RAN_16	RP-020317	090	-	Correction to HS-SCCH Power Control (TDD)	5.0.0	5.1.0
20/09/02	RAN_17	RP-020586	091	1	Corrections to 25.224 for HSDPA	5.1.0	5.2.0
20/09/02	RAN_17	RP-020572	094	2	Corrections to transmit diversity mode for TDD beacon-function physical channels	5.1.0	5.2.0
20/09/02	RAN_17	RP-020577	097	1	Corrections to uplink synchronisation procedure	5.1.0	5.2.0
20/09/02	RAN_17	RP-020577	099	-	Correction to the PRACH open loop power control procedure for 1.28 Mcps TDD	5.1.0	5.2.0
20/09/02	RAN_17	RP-020579	101	1	Corrections to transmit diversity mode for TDD beacon-function physical channels	5.1.0	5.2.0
15/10/02	-	-	-	-	Separate subclause 5.1.1.3, which was by accident merged into the header of subclause 5.1.1.4	5.2.0	5.2.1
22/12/02	RAN_18	RP-020854	102	1	Corrections and clarifications to TDD CQI description	5.2.1	5.3.0
22/12/02	RAN_18	RP-020852	105	-	Editorial modification to the section numberings	5.2.1	5.3.0
24/03/03	RAN_19	RP-030141	109	1	Corrections to TPC Procedures During a DL Transmission Pause	5.3.0	5.4.0
24/03/03	RAN_19	RP-030141	114	1	Corrections to link adaptation procedure for UTRA TDD (3.84 Mcps Option)	5.3.0	5.4.0
24/03/03	RAN_19	RP-030141	115	2	Minimum timing requirement for CQI transmission on HS-SICH in UTRA TDD	5.3.0	5.4.0
24/03/03	RAN_19	RP-030141	117	2	Clarification of downlink closed loop power control procedures for 3.84 Mcps TDD	5.3.0	5.4.0
24/03/03	RAN_19	RP-030133	119	2	Corrections to the LCR power control procedure	5.3.0	5.4.0
24/06/03	RAN_20	RP-030277	120	-	Clarifications for the 1.28Mcps TDD power control procedure	5.4.0	5.5.0
22/09/03	RAN_21	RP-030460	121	3	Clarification on PDSCH Downlink Power Control Procedures	5.5.0	5.6.0
22/09/03	RAN_21	RP-030476	125	1	DTX and Special Bursts in case of no data on S-CCPCH and Beacon Channels	5.5.0	5.6.0
06/01/04	RAN_22	RP-030698	128	1	Correction to computed gain factors with signalled reference gain factor values	5.6.0	5.7.0
13/01/04	RAN_22	-	-	-	Created for M.1457 update	5.7.0	6.0.0
09/06/04	RAN_24	RP-040235	131	2	Addition of TSTD for S-CCPCH in 3.84Mcps TDD	6.0.0	6.1.0
07/09/04	RAN_25	RP-040316	134	-	Transmit diversity usage for beacon channels in LCR TDD	6.1.0	6.2.0
07/09/04	RAN_25	RP-040319	137	1	Corrections of radio access procedure for 1.28Mcps TDD	6.1.0	6.2.0
13/12/04	RAN_26	RP-040451	138	-	Introduction of MICH	6.2.0	6.3.0
13/12/04	RAN_26	RP-040452	139	-	Introduction of MBMS soft combining for TDD	6.2.0	6.3.0
14/03/05	RAN_27	RP-050097	140	2	Improvements to uplink closed-loop power control for 1.28Mcps TDD	6.3.0	6.4.0
14/03/05	RAN_27	RP-050089	141	-	Release 6 HS-DSCH operation without a DL DPCH for 3.84Mcps TDD	6.3.0	6.4.0
16/06/05	RAN_28	RP-050255	144	2	Clarification of UpPCH Sub-channel for 1.28 Mcps TDD	6.4.0	6.5.0
12/12/05	RAN_30	RP-050724	0146	1	Clarify the power control procedure of HS-SCCH for TDD	6.5.0	6.6.0
20/03/06	RAN_31	RP-060078	0149	-	Introduction of the Physical Layer Common Control Channel (PLCCH)	6.6.0	7.0.0
20/03/06	RAN_31	RP-060079	0150	-	Introduction of 7.68Mcps TDD option	6.6.0	7.0.0
29/09/06	RAN_33	RP-060497	0152	-	Release 7 Timing Advance (3.84 Mcps and 7.68 Mcps TDD)	7.0.0	7.1.0
29/09/06	RAN_33	RP-060492	0153	-	Introduction of E-DCH for 3.84Mcps and 7.68Mcps TDD	7.0.0	7.1.0
29/09/06	RAN_33	-	-	-	Editorial correction for Tdoc number of CR0140R2 from RP-050096 to RP-050097 on table of history change	7.0.0	7.1.0
13/03/07	RAN_35	RP-070118	0159	2	Introduction of E-DCH for 1.28Mcps TDD	7.1.0	7.2.0
13/03/07	RAN_35	RP-070113	0155	1	Modification on the power control function of HS-SICH for LCR TDD	7.1.0	7.2.0
13/03/07	RAN_35	RP-070113	0158	2	Clarification of closed Loop Uplink HS-SICH Power Control for 1.28Mcps TDD	7.1.0	7.2.0
30/05/07	RAN_36	RP-070385	0160	1	Support for MBSFN operation	7.2.0	7.3.0
30/05/07	RAN_36	RP-070386	0162	1	Support for 1.28Mcps TDD MBSFN operation	7.2.0	7.3.0
11/09/07	RAN_37	RP-070640	0164	1	Improvement on the power control of E-PUCH in 1.28Mcps TDD	7.3.0	7.4.0
11/09/07	RAN_37	RP-070650	0163	1	Introduction of multi-frequency operation for 1.28Mcps TDD	7.3.0	7.4.0
14/09/07	RAN_37	RP-070726	0166	1	Correction to the calculating formula of SIR	7.3.0	7.4.0
27/11/07	RAN_38	RP-070942	0172	-	Clarification of gain factor β_e and P_{e-base} in LCR TDD EUL	7.4.0	7.5.0
27/11/07	RAN_38	RP-070943	0171	1	More improvement on dedicated carrier for 1.28Mcps TDD MBMS	7.4.0	7.5.0
04/03/08	RAN_39	RP-080140	0170	2	EUL power control improvements for 1.28Mcps TDD	7.5.0	7.6.0

Change history							
Date	TSG #	TSG Doc.	CR	Rev	Subject/Comment	Old	New
04/03/08	RAN_39	RP-080140	0176	-	Improvement of the UL synchronisation of E-PUCH for 1.28Mcps TDD EUL	7.5.0	7.6.0
04/03/08	RAN_39	RP-080140	0177	1	Clarification and Correction of E-PUCH power control for LCR TDD	7.5.0	7.6.0
04/03/08	RAN_39	-	-	-	Creation of Release 8 further to RAN_39 decision	7.6.0	8.0.0
09/09/08	RAN_41	RP-080661	186	4	HS-SCCH and HS-SICH power control clarification for 1.28Mcps TDD	8.0.0	8.1.0
09/09/08	RAN_41	RP-080664	187	-	Use of Special Bursts for DTX on MBSFN FACH in 1.28 Mcps TDD	8.0.0	8.1.0
09/09/08	RAN_41	RP-080661	188	-	Correction of E-PUCH power control for 1.28 Mcps TDD EUL	8.0.0	8.1.0
09/09/08	RAN_41	RP-080661	190	1	Clarification of the E-AGCH monitoring for 1.28Mcps TDD EUL	8.0.0	8.1.0
09/09/08	RAN_41	RP-080661	192	-	Correction of UpPCHPOS bit number in subclause 5.2.7	8.0.0	8.1.0
09/09/08	RAN_41	RP-080661	193	-	EUL power control clarification for 1.28Mcps TDD	8.0.0	8.1.0
09/09/08	RAN_41	RP-080661	194	1	EUL power control improvement for 1.28Mcps TDD	8.0.0	8.1.0
03/12/08	RAN_42	RP-080976	199	1	Modification of HS-SICH sync description for 1.28Mcps TDD	8.1.0	8.2.0
03/12/08	RAN_42	RP-080976	201	1	Clarification of precision and quantization mode for coderate and beta of E-PUCH for 1.28Mcps TDD EUL	8.1.0	8.2.0
03/12/08	RAN_42	RP-080987	202	1	Introduction of the Enhanced CELL_FACH, CELL_PCH, URA_PCH state for 1.28Mcps TDD	8.1.0	8.2.0
03/12/08	RAN_42	RP-081118	203	1	Support for 3.84 Mcps MBSFN IMB operation	8.1.0	8.2.0
03/03/09	RAN_43	RP-090230	205	-	Clarification of the beta value for smallest E-TFC of E-PUCH for 1.28Mcps TDD EUL	8.2.0	8.3.0
03/03/09	RAN_43	RP-090240	206	1	Introducing of CPC for 1.28Mcps TDD	8.2.0	8.3.0
03/03/09	RAN_43	RP-090241	207	1	Introducing of MIMO for 1.28Mcps TDD	8.2.0	8.3.0
03/03/09	RAN_43	RP-090230	209	2	E-DCH power control clarification for 1.28Mcps TDD	8.2.0	8.3.0
26/05/09	RAN_44	RP-090533	210	1	Clarification of HS-SICH and E-PUCH power control in semi-persistent transmission for LCR TDD	8.3.0	8.4.0
26/05/09	RAN_44	RP-090533	211	1	Clarification of E-PUCH synchronization in semi-persistent transmission for LCR TDD	8.3.0	8.4.0
26/05/09	RAN_44	RP-090533	212	2	Clarification of DRX operation in CPC for LCR TDD	8.3.0	8.4.0
26/05/09	RAN_44	RP-090526	216	-	Clarification of the transmit power for E-RUCCH for 1.28Mcps TDD	8.3.0	8.4.0
26/05/09	RAN_44	RP-090531	218	2	Pilot power behaviour for MBSFN IMB	8.3.0	8.4.0
15/09/09	RAN_45	RP-090892	219	4	Clarification on HS-DSCH procedure when using BCCH specific H-RNTI in CELL_PCH or URA_PCH state for 1.28Mcps TDD	8.4.0	8.5.0
15/09/09	RAN_45	RP-090892	224	1	Change the timing definition in CELL_PCH for 1.28Mcps TDD	8.4.0	8.5.0
15/09/09	RAN_45	RP-090887	226	2	Clarification of SNPL calculation and reporting for 1.28 Mcps TDD	8.4.0	8.5.0
01/12/09	RAN_46	RP-091258	217	5	Correction of Out of synchronisation handling for 1.28Mcps TDD CPC usage	8.5.0	8.6.0
01/12/09	RAN_46	RP-091166	230	3	Correction on Control Channel DRX description for 1.28Mcps TDD	8.5.0	8.6.0
01/12/09	RAN_46	RP-091166	232	1	Clarification of the Control Channel DRX operation for 1.28Mcps TDD	8.5.0	8.6.0
01/12/09	RAN_46	RP-091167	234	1	Terminology correction for 1.28Mcps TDD standalone midamble channel	8.5.0	8.6.0
01/12/09	RAN_46	RP-091169	236	-	Clarification of HS-DSCH channel quality indication procedure in CELL_FACH state for 1.28Mcps TDD	8.5.0	8.6.0
01/12/09	RAN_46	-	-	-	Creation of Release 9 (v9.0.0) at RAN#46	8.6.0	9.0.0
16/03/10	RAN_47	RP-100201	244	-	Clarification of the TPC and SS on HS-SCCH uplink synchronization establishment command for 1.28Mcps TDD	9.0.0	9.1.0
16/03/10	RAN_47	RP-100202	246	1	Clarification of HS-DSCH Channel Quality Indication Procedure for 1.28Mcps TDD	9.0.0	9.1.0
16/03/10	RAN_47	RP-100201	248	-	Clarification of ePCH modulation scheme	9.0.0	9.1.0
14/09/10	RAN_49	RP-100896	254	2	Clarification on HS-DSCH transmission in CELL_PCH or URA_PCH state for 1.28Mcps TDD	9.1.0	9.2.0
07/12/10	RAN_50	RP-101314	261	-	Correction of MC-HSDPA DRX for 1.28Mcps TDD	9.2.0	9.3.0
07/12/10	RAN_50	RP-101316	263	2	Clarification for special burst power calculation for 1.28Mcps TDD	9.2.0	9.3.0
07/12/10	RAN_50	RP-101317	257	3	Introduction of MC-HSUPA for LCR TDD	9.3.0	10.0.0
07/12/10	RAN_50	RP-101319	259	1	Introduction of MU-MIMO for LCR TDD	9.3.0	10.0.0
15/03/11	RAN_51	RP-110252	265	1	Correction of the special burst transmission power calculation for 1.28Mcps TDD	10.0.0	10.1.0
01/06/11	RAN_52	RP-110817	266	-	Clarification on SCCPCH selection for LCR TDD	10.1.0	10.2.0
15/09/11	RAN_53	RP-111227	270	2	Clarifications on SYNC-UL signatures for E-RUCCH procedure for LCR TDD	10.2.0	10.3.0
2012-09	SP_57	-	-	-	Update to Rel-11 version (MCC)	10.3.0	11.0.0
04/12/12	RAN_58	RP-121847	272	2	Clarification about the frequency on which UE initiates uplink synchronization in enhanced CELL_PCH state for 1.28Mcps TDD	11.0.0	11.1.0