

3GPP TS 25.201 V11.1.0 (2012-12)

Technical Specification

3rd Generation Partnership Project; Technical Specification Group Radio Access Network; Physical layer - General description (Release 11)



The present document has been developed within the 3rd Generation Partnership Project (3GPP™) and may be further elaborated for the purposes of 3GPP.

The present document has not been subject to any approval process by the 3GPP Organisational Partners and shall not be implemented. This Specification is provided for future development work within 3GPP only. The Organisational Partners accept no liability for any use of this Specification. Specifications and reports for implementation of the 3GPP™ system should be obtained via the 3GPP Organisational Partners' Publications Offices.

Keywords

UMTS, radio, layer 1

3GPP

Postal address

3GPP support office address

650 Route des Lucioles - Sophia Antipolis
Valbonne - FRANCE
Tel.: +33 4 92 94 42 00 Fax: +33 4 93 65 47 16

Internet

<http://www.3gpp.org>

Copyright Notification

No part may be reproduced except as authorized by written permission.
The copyright and the foregoing restriction extend to reproduction in all media.

© 2012, 3GPP Organizational Partners (ARIB, ATIS, CCSA, ETSI, TTA, TTC).
All rights reserved.

UMTS™ is a Trade Mark of ETSI registered for the benefit of its members
3GPP™ is a Trade Mark of ETSI registered for the benefit of its Members and of the 3GPP Organizational Partners
LTE™ is a Trade Mark of ETSI currently being registered for the benefit of its Members and of the 3GPP Organizational Partners
GSM® and the GSM logo are registered and owned by the GSM Association

Contents

Foreword	4
1 Scope	5
2 References.....	5
3 Abbreviations	6
4 General description of Layer 1	7
4.1 Relation to other layers.....	7
4.1.1 General Protocol Architecture	7
4.1.2 Service provided to higher layers	7
4.2 General description of Layer 1	8
4.2.1 Multiple Access.....	8
4.2.2 Channel coding and interleaving	9
4.2.3 Modulation and spreading	9
4.2.4 Physical layer procedures	9
4.2.5 Physical layer measurements	10
4.2.6 Relationship of the physical layer functions.....	10
5 Document structure of physical layer specification	11
5.1 Overview	11
5.2 TS 25.201: Physical layer – General description	11
5.3 TS 25.211: Physical channels and mapping of transport channels onto physical channels (FDD)	11
5.4 TS 25.212: Multiplexing and channel coding (FDD).....	11
5.5 TS 25.213: Spreading and modulation (FDD).....	12
5.6 TS 25.214: Physical layer procedures (FDD).....	12
5.7 TS 25.215: Physical layer – Measurements (FDD).....	12
5.8 TS 25.221: Physical channels and mapping of transport channels onto physical channels (TDD)	12
5.9 TS 25.222: Multiplexing and channel coding (TDD)	13
5.10 TS 25.223: Spreading and modulation (TDD)	13
5.11 TS 25.224: Physical layer procedures (TDD).....	13
5.12 TS 25.225: Physical layer – Measurements (TDD).....	13
5.13 TR 25.833: Physical layer items not for inclusion in Release ‘99	13
5.14 TR 25.944: Channel coding and multiplexing examples	13
Annex A (informative): Preferred mathematical notations.....	14
Annex B (informative): Change history.....	15

Foreword

This Technical Specification (TS) has been produced by the 3rd Generation Partnership Project (3GPP).

The contents of the present document are subject to continuing work within the TSG and may change following formal TSG approval. Should the TSG modify the contents of the present document, it will be re-released by the TSG with an identifying change of release date and an increase in version number as follows:

Version x.y.z

where:

- x the first digit:
 - 1 presented to TSG for information;
 - 2 presented to TSG for approval;
 - 3 or greater indicates TSG approved document under change control.
- y the second digit is incremented for all changes of substance, i.e. technical enhancements, corrections, updates, etc.
- z the third digit is incremented when editorial only changes have been incorporated in the document.

1 Scope

The present document describes a general description of the physical layer of the UTRA radio interface. The present document also describes the document structure of the 3GPP physical layer specifications, i.e. TS 25.200 series. The TS 25.200 series specifies the Uu point for the 3G mobile system, and defines the minimum level of specifications required for basic connections in terms of mutual connectivity and compatibility.

2 References

The following documents contain provisions which, through reference in this text, constitute provisions of the present document.

- References are either specific (identified by date of publication, edition number, version number, etc.) or non-specific.
- For a specific reference, subsequent revisions do not apply.
- For a non-specific reference, the latest version applies. In the case of a reference to a 3GPP document (including a GSM document), a non-specific reference implicitly refers to the latest version of that document *in the same Release as the present document*.

- [1] 3GPP TS 25.211: "Physical channels and mapping of transport channels onto physical channels (FDD)".
- [2] 3GPP TS 25.212: "Multiplexing and channel coding (FDD)".
- [3] 3GPP TS 25.213: "Spreading and modulation (FDD)".
- [4] 3GPP TS 25.214: "Physical layer procedures (FDD)".
- [5] 3GPP TS 25.215: "Physical layer – Measurements (FDD)".
- [6] 3GPP TS 25.221: "Physical channels and mapping of transport channels onto physical channels (TDD)".
- [7] 3GPP TS 25.222: "Multiplexing and channel coding (TDD)".
- [8] 3GPP TS 25.223: "Spreading and modulation (TDD)".
- [9] 3GPP TS 25.224: "Physical layer procedures (TDD)".
- [10] 3GPP TS 25.225: "Physical layer – Measurements (TDD)".
- [11] 3GPP TR 25.833: "Physical layer items not for inclusion in Release '99".
- [12] 3GPP TR 25.944: "Channel coding and multiplexing examples".
- [13] 3GPP TS 25.301: "Radio Interface Protocol Architecture".
- [14] 3GPP TS 25.302: "Services provided by the physical layer".
- [15] 3GPP TS 25.101: "UE Radio transmission and reception (FDD)".
- [16] 3GPP TS 25.102: "UE Radio transmission and reception (TDD)".
- [17] 3GPP TS 25.104: "BTS Radio transmission and reception (FDD)".
- [18] 3GPP TS 25.105: "BTS Radio transmission and reception (TDD)".

3 Abbreviations

For the purposes of the present document, the following abbreviations apply:

16QAM	16 Quadrature Amplitude Modulation
64QAM	64 Quadrature Amplitude Modulation
ARQ	Automatic Repeat Request
BER	Bit Error Rate
CCTrCH	Coded Composite Transport Channel
DCA	Dynamic channel allocation
DCH	Dedicated Channel
DS-CDMA	Direct-Sequence Code Division Multiple Access
DSCH	Downlink Shared Channel
DwPCH	Downlink Pilot Channel
DwPTS	Downlink Pilot Time Slot
E-DCH	Enhanced Dedicated Channel
E-HICH	E-DCH Hybrid ARQ Indicator Channel
E-RGCH	E-DCH Relative Grant Channel
FDD	Frequency Division Duplex
FEC	Forward Error Correction
FER	Frame Error Rate
GSM	Global System for Mobile Communication
HS-DSCH	High Speed Downlink Shared channel
HS-SCCH	HS-DSCH Shared Control Channel
L1	Layer 1 (physical layer)
L2	Layer 2 (data link layer)
L3	Layer 3 (network layer)
LAC	Link Access Control
MAC	Medium Access Control
MBSFN	MBMS over a Single Frequency Network
Mcps	Mega Chip Per Second
MIMO	Multiple Input Multiple Output
QPSK	Quaternary Phase Shift Keying
RACH	Random Access Channel
RF	Radio Frequency
RLC	Radio Link Control
RRC	Radio Resource Control
SAP	Service Access Point
SCH	Synchronisation Channel
SIR	Signal-to-Interference Ratio
TDD	Time Division Duplex
TDMA	Time Division Multiple Access
TFCI	Transport-Format Combination Indicator
UE	User Equipment
UMTS	Universal Mobile Telecommunications System
UpPTS	Uplink Pilot Time Slot
UpPCH	Uplink Pilot Channel
UTRA	UMTS Terrestrial Radio Access
UTRAN	UMTS Terrestrial Radio Access Network
WCDMA	Wide-band Code Division Multiple Access

4 General description of Layer 1

4.1 Relation to other layers

4.1.1 General Protocol Architecture

Radio interface which is prescribed by this specification means the Uu point between User Equipment (UE) and network. The radio interface is composed of Layers 1, 2 and 3. Layer 1 is based on WCDMA/TD-SCDMA technology and the TS 25.200 series describes the Layer-1 specification. Layers 2 and 3 of the radio interface are described in the TS 25.300 series.

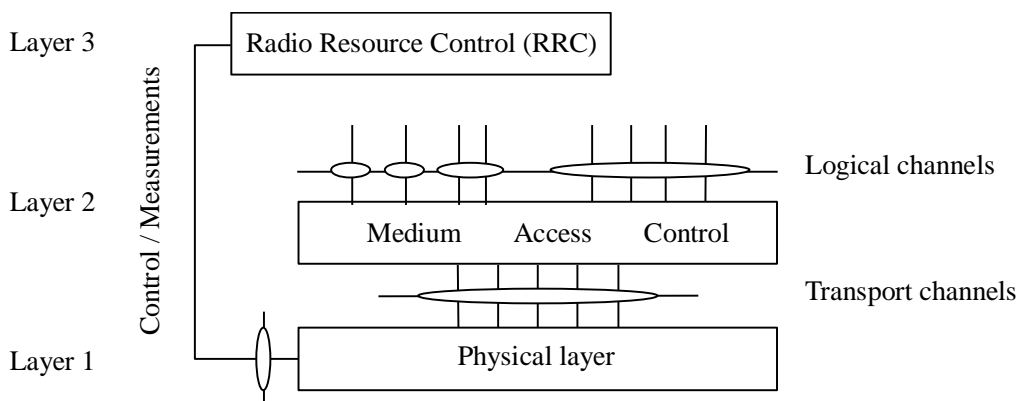

Figure 1: Radio interface protocol architecture around the physical layer

Figure 1 shows the UTRA radio interface protocol architecture around the physical layer (Layer 1). The physical layer interfaces the Medium Access Control (MAC) sub-layer of Layer 2 and the Radio Resource Control (RRC) Layer of Layer 3. The circles between different layer/sub-layers indicate Service Access Points (SAPs). The physical layer offers different Transport channels to MAC. A transport channel is characterized by how the information is transferred over the radio interface. MAC offers different Logical channels to the Radio Link Control (RLC) sub-layer of Layer 2. A logical channel is characterized by the type of information transferred. Physical channels are defined in the physical layer. There are two duplex modes: Frequency Division Duplex (FDD) and Time Division Duplex (TDD). In the FDD mode a physical channel is characterized by the code, frequency and in the uplink the relative phase (I/Q); in addition E-HICH and E-RGCH are also defined by a specific orthogonal signature sequence. In the TDD mode the physical channels are also characterized by the timeslot and additionally, the E-HICH is further defined by a specific orthogonal signature sequence. For 1.28Mcps TDD, the E-HICH can be also further defined by a group of orthogonal signature sequences. The physical layer is controlled by RRC.

4.1.2 Service provided to higher layers

The physical layer offers data transport services to higher layers. The access to these services is through the use of transport channels via the MAC sub-layer. The physical layer is expected to perform the following functions in order to provide the data transport service. See also TS 25.302:

- Macrodiversity distribution/combining and soft handover execution.
- Error detection on transport channels and indication to higher layers.
- FEC encoding/decoding of transport channels.
- Multiplexing of transport channels and demultiplexing of coded composite transport channels (CCTrCHs).
- Rate matching of coded transport channels to physical channels.
- Mapping of coded composite transport channels on physical channels.
- Power weighting and combining of physical channels.

- Modulation and spreading/demodulation and despreading of physical channels.
- Frequency and time (chip, bit, slot, frame) synchronisation.
- Radio characteristics measurements including FER, SIR, Interference Power, etc., and indication to higher layers.
- Inner - loop power control.
- RF processing. (Note: RF processing is defined in TS 25.100 series).
- synchronization shift control
- Beamforming
- MIMO transmission
- Hybrid ARQ soft-combining for HS-DSCH and E-DCH

When network elements (UEs and network) provide compatible service bearers (for example support a speech bearer) they should be assured of successful interworking. Moreover, different implementation options of the same (optional) feature would lead to incompatibility between UE and network. Therefore, this shall be avoided.

4.2 General description of Layer 1

4.2.1 Multiple Access

The access scheme is Direct-Sequence Code Division Multiple Access (DS-CDMA) with information either spread over approximately 5 MHz (FDD and 3.84 Mcps TDD) bandwidth, thus also often denoted as Wideband CDMA (WCDMA) due that nature, 10MHz (7.68 Mcps TDD) bandwidth, or 1.6MHz (1.28Mcps TDD), thus also often denoted as Narrowband CDMA. UTRA has two modes, FDD (Frequency Division Duplex) & TDD (Time Division Duplex), for operating with paired and unpaired bands respectively. The possibility to operate in either FDD or TDD mode allows for efficient utilisation of the available spectrum according to the frequency allocation in different regions. FDD and TDD modes are defined as follows:

FDD: A duplex method whereby uplink and downlink transmissions use two separated radio frequencies. In the FDD, each uplink and downlink uses the different frequency band. A pair of frequency bands which have specified separation shall be assigned for the system.

TDD: A duplex method whereby uplink and downlink transmissions are carried over same radio frequency by using synchronised time intervals. In the TDD, time slots in a physical channel are divided into transmission and reception part. Information on uplink and downlink are transmitted reciprocally.

UTRA TDD has three options, the 3.84Mcps option and the 1.28Mcps option, the 7.68Mcps TDD option. In UTRA TDD there is TDMA component in the multiple access in addition to DS-CDMA. Thus the multiple access has been also often denoted as TDMA/CDMA due to the added TDMA nature.

A 10 ms radio frame is divided into 15 slots (2560 chip/slot at the chip rate 3.84 Mcps). A physical channel is therefore defined as a code (or number of codes) and additionally in TDD mode the sequence of time slots completes the definition of a physical channel. In FDD, for HS-DSCH, E-DCH and associated signalling channels, 2ms sub-frames consisting of 3 slots are defined.

The information rate of the channel varies with the symbol rate being derived from the 3.84 Mcps chip rate and the spreading factor. Spreading factors are from 256 to 2 with FDD uplink, from 512 to 4 with FDD downlink, and from 16 to 1 for TDD uplink and downlink. Thus the respective modulation symbol rates vary from 1920 k symbols/s to 15 k symbols/s (7.5 k symbols/s) for FDD uplink (downlink), and for TDD the momentary modulation symbol rates shall vary from 3.84 M symbols/s to 240 k symbols/s.

For the 7.68Mcps TDD option, a 10 ms radio frame is divided into 15 slots (5120 chip/slot). A physical channel is therefore defined as a code (or number of codes) and the sequence of time slots.

The information rate of the channel varies with the symbol rate being derived from the 7.68 Mcps chip rate and the spreading factor. Spreading factors are from 32 to 1 for both uplink and downlink. Thus the respective modulation symbol rates vary from 7.68 M symbols/s to 240 k symbols/s.

For 1.28Mcps TDD option, a 10 ms radio frame is divided into two 5ms sub-frames. In each sub-frame, there are 7 normal time slots and 3 special time slots. Note that in case of entire carrier dedicated to MBSFN there are 7 normal MBSFN Traffic time slots and 1 short MBSFN Special time slot in each sub-frame. A basic physical channel is therefore characterised by the frequency, code and time slot.

The information rate of the channel varies with the symbol rate being derived from the 1.28 Mcps chiprate and the spreading factor. Spreading factors is from 16 to 1 for both uplink and downlink. Thus the respective modulation symbol rates shall vary from 80.0K symbols/s to 1.28M symbols/s.

4.2.2 Channel coding and interleaving

For the channel coding in UTRA two options are supported for FDD and three options are supported for TDD:

- Convolutional coding.
- Turbo coding.
- No coding (only TDD).

Channel coding selection is indicated by higher layers. In order to randomise transmission errors, bit interleaving is performed further.

4.2.3 Modulation and spreading

The UTRA modulation scheme is QPSK (8PSK is also used for 1.28Mcps TDD option). For HS-DSCH transmission, 16QAM and 64QAM can also be used. 16QAM and 64QAM are further supported for E-DCH transmission, and 16QAM is supported for MBSFN¹ FACH transmissions. Pulse shaping is specified in the TS 25.100 series.

With CDMA nature the spreading (& scrambling) process is closely associated with modulation. In UTRA different families of spreading codes are used to spread the signal:

- For separating channels from same source, channelisation codes derived with the code tree structure as given in TS 25.213 and 25.223 are used.
- For separating different cells the following solutions are supported.
- FDD mode: Gold codes with 10 ms period (38400 chips at 3.84 Mcps) used, with the actual code itself length $2^{18}-1$ chips, as defined in TS 25.213.
- TDD mode: for the 3.84Mcps and 1.28Mcps TDD options, scrambling codes with the length 16 are used as defined in TS 25.223; for the 7.68Mcps TDD option, scrambling codes with length 32 are used.
- For separating different UEs the following code families are defined.
- FDD mode: Gold codes with 10 ms period, or alternatively S(2) codes 256 chip period.
- TDD mode: for the 3.84Mcps and 1.28Mcps TDD options, codes with period of 16 chips and midamble sequences of different length depending on the environment; for the 7.68Mcps TDD option, codes with period of 32 chips and midamble sequences of different length depending on the environment.

4.2.4 Physical layer procedures

There are several physical layer procedures involved with UTRA operation. Such procedures covered by physical layer description are:

- 1) The power control, inner loop for FDD mode, and for the 3.84Mcps TDD and 7.68Mcps TDD options open loop in uplink and inner loop in downlink, for 1.28Mcps TDD option, open loop in uplink and inner loop in both uplink and downlink.
- 2) Cell search operation.

¹ MBSFN transmission is characterised by a group of synchronised base stations transmitting the same wave form by using a common scrambling code

- 3) Uplink synchronization control with open and closed loop.
- 4) Random access
- 5) Procedures related to HS-DSCH transmission, including HS-SCCH less operation and MIMO transmission.
- 6) Procedures related to E-DCH transmission, including MIMO transmission.
- 7) Procedures related to discontinuous transmission and reception.

4.2.5 Physical layer measurements

Radio characteristics including FER, SIR, Interference power, etc., are measured and reported to higher layers and network. Such measurements are:

- 1) Handover measurements for handover within UTRA. Specific features being determined in addition to the relative strength of the cell, for the FDD mode the timing relation between for cells for support of asynchronous soft handover.
- 2) The measurement procedures for preparation for handover to GSM900/GSM1800.
- 3) The measurement procedures for UE before random access process.
- 4) The measurement procedures for Dynamic Channel Allocation (DCA) of TDD mode.
- 5) UTRAN measurements.

4.2.6 Relationship of the physical layer functions

The functionality of the layer 1 is split over several specifications each for FDD and TDD. The following figures, although not categorical, show as an introduction the relationship of layer 1 functions by specification in terms of users plane information flow.

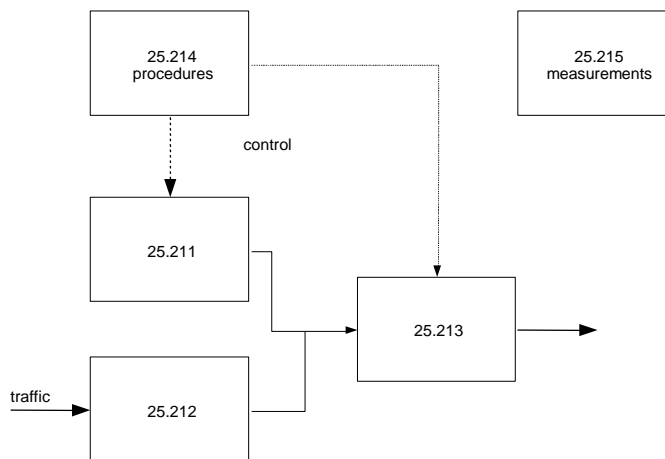

Figure 2 - FDD layer 1 functions relationships by specification

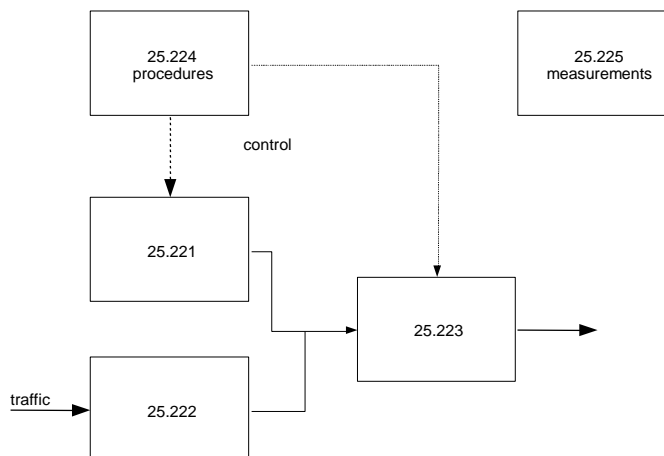

Figure 3 - TDD layer 1 functions relationships by specification

5 Document structure of physical layer specification

5.1 Overview

The physical layer specification consists of a general document (TS 25.201), five FDD mode documents (TS 25.211 through 25.215), five TDD mode documents (TS 25.221 through 25.225). In addition, there are two technical reports (TR 25.833 and 25.944).

5.2 TS 25.201: Physical layer – General description

The scope is to describe:

- the contents of the Layer 1 documents (TS 25.200 series);
- where to find information;
- a general description of Layer 1.

5.3 TS 25.211: Physical channels and mapping of transport channels onto physical channels (FDD)

The scope is to establish the characteristics of the Layer-1 transport channels and physical channels in the FDD mode, and to specify:

- the different transport channels that exist;
- which physical channels exist;
- what is the structure of each physical channel, slot format etc.;
- relative timing between different physical channels in the same link, and relative timing between uplink and downlink;
- mapping of transport channels onto the physical channels.

5.4 TS 25.212: Multiplexing and channel coding (FDD)

The scope is to describe multiplexing, channel coding and interleaving in the FDD mode, and to specify:

- coding and multiplexing of transport channels into CCTrCHs;
- channel coding alternatives;
- coding for Layer 1 control information, such as TFCI;
- the different interleavers;
- how is rate matching done;
- physical channel segmentation and mapping.

5.5 TS 25.213: Spreading and modulation (FDD)

The scope is to establish the characteristics of the spreading and modulation in the FDD mode, and to specify:

- the spreading (channelisation plus scrambling);
- generation of channelisation and scrambling codes;
- generation of RACH preamble codes;
- generation of SCH synchronisation codes;
- modulation.

RF channel arrangements and Pulse shaping are specified in TS 25.101 for UE and in TS 25.104 for Node-B.

5.6 TS 25.214: Physical layer procedures (FDD)

The scope is to establish the characteristics of the physical layer procedures in the FDD mode, and to specify:

- cell search procedures;
- power control procedures;
- random access procedure.

5.7 TS 25.215: Physical layer – Measurements (FDD)

The scope is to establish the characteristics of the physical layer measurements in the FDD mode, and to specify:

- the measurements that Layer 1 is to perform;
- reporting of measurements to higher layers and network;
- handover measurements, idle-mode measurements etc.

5.8 TS 25.221: Physical channels and mapping of transport channels onto physical channels (TDD)

The scope is to establish the characteristics of the Layer-1 transport channels and physical channels in the TDD mode, and to specify:

- transport channels;
- physical channels, structure and contents;
- mapping of transport channels onto the physical channels.

5.9 TS 25.222: Multiplexing and channel coding (TDD)

The scope is to describe multiplexing, channel coding and interleaving in the TDD mode, and to specify:

- channel coding and multiplexing of transport channels into CCTrCHs;
- channel coding alternatives;
- coding for Layer 1 control information, such as TFCI;
- interleaving;
- rate matching;
- physical channel segmentation and mapping.

5.10 TS 25.223: Spreading and modulation (TDD)

The scope is to establish the characteristics of the spreading and modulation in the TDD mode, and to specify:

- data modulation;
- spreading;
- generation of synchronisation codes.

RF channel arrangements and Pulse shaping are specified in TS 25.102 for UE and in TS 25.105 for Node-B.

5.11 TS 25.224: Physical layer procedures (TDD)

The scope is to establish the characteristics of the physical layer procedures in the TDD mode, and to specify:

- cell synchronisation;
- timing advance;
- power control procedures;
- idle mode tasks.

5.12 TS 25.225: Physical layer – Measurements (TDD)

The scope is to establish the characteristics of the physical layer measurements in the TDD mode, and to specify:

- the measurements that Layer 1 is to perform;
- reporting of measurements to higher layers and network;
- handover measurements, idle-mode measurements etc.

5.13 TR 25.833: Physical layer items not for inclusion in Release '99

The scope is to collect materials on UTRA physical layer items not included in the Release '99 specification documents, such as DSCH control channel, FAUSCH, Hybrid ARQ, 4-state SCCC turbo coding and ODMA.

5.14 TR 25.944: Channel coding and multiplexing examples

The scope is to describe examples of channel coding and multiplexing for transport channels of various types and cases.

Annex A (informative): Preferred mathematical notations

The following table contains the preferred mathematical notations used in L1 documentation.

Item	Notation
multiply product	cross sign, e.g. $a \times b$
matrix product	dot sign, e.g. $a \cdot b$
scalar product (product of a matrix by a scalar)	dot sign, scalar should precede matrix e.g. $(1 + j) \cdot \begin{bmatrix} u \\ v \end{bmatrix}$
matrix dimensioning	number of rows \times number of column, e.g.: $R \times C$
Kronecker product	$a \otimes b$
bracketing of sets (all elements of same type, not ordered elements)	curly brackets {}, e.g. $\{a_1, a_2, \dots, a_p\}$, or $\{a_i\}_{i \in \{1, 2, \dots, p\}}$
bracketing of lists (all elements not necessary of same type, ordered elements)	round brackets (), e.g. (A, u, x)
bracketing of sequences (all elements of same type, ordered elements)	angle brackets, e.g. $\langle a_1, a_2, \dots, a_p \rangle$ or $\langle a_i \rangle_{i \in \{1, 2, \dots, p\}}$
bracketing of function argument	round brackets, e.g. $f(x)$
bracketing of array index	square brackets, e.g. $a[x]$
bracketing of matrix or vector	square brackets [], e.g. $\begin{bmatrix} x \\ y \end{bmatrix}$, $\begin{bmatrix} x & y \end{bmatrix}$, or $\begin{bmatrix} 1 & 1 \\ 1 & -1 \end{bmatrix}$
Separation of indexes	use a comma : e.g. $N_{i,j}$
use of italic for symbols	a symbol should be either in italic or in normal font, but mixing up should be avoided.
bracketing of arithmetic expression to force precedence of operations	round brackets : e.g. $(a + b) \times c$
necessity of bracketing arithmetic expressions	When only + and \times bracketing is not necessary. When the mod operator is used explicit bracketing of mod operands and possibly result should be done.
number type	in a context of non negative integer numbers, some notes should stress when a number is signed, or possibly fractional.
binary xor and and	respectively use + or \cdot . If no "mod 2" is explicitly in the expression some text should stress that the operation is modulo 2.
matrix or vector transpose	v^T
1 \times 1 matrices	implicitly cast to its unique element.
vector dot product	$u^T \cdot v$ for column vectors, and $u \cdot v^T$ for line vectors
complex conjugate	v^*
matrix or vector Hermitian transpose	v^H
real part and imaginary part of complex numbers.	Re(x) and Im(x)

Annex B (informative): Change history

Change history							
Date	TSG #	TSG Doc.	CR	Rev	Subject/Comment	Old	New
	RAN_05	RP-99586	-		Approved at TSG RAN #5 and placed under Change Control	-	3.0.0
14/01/00	-	-	-		Modified in terms of formality. The contents were not changed.	3.0.0	3.0.1
31/03/00	RAN_07	RP-000059	001	-	Editorial revision	3.0.1	3.0.2
26/06/00	RAN_08	RP-000264	002	-	Corrections to align with TS 25.212 and TR 25.944	3.0.2	3.1.0
26/06/00	RAN_08	RP-000264	003	1	Editorial corrections	3.0.2	3.1.0
26/06/00	RAN_08	RP-000264	004	-	Physical layer information flow	3.0.2	3.1.0
26/06/00	RAN_08	RP-000264	005	1	Preferred mathematical notation for editorial unity of L1 documentation	3.0.2	3.1.0
16/03/01	RAN_11	-	-	-	Approved as Release 4 specification (v4.0.0) at TSG RAN #11	3.1.0	4.0.0
16/03/01	RAN_11	RP-010071	006	1	Inclusion of 1.28Mcps TDD in TS 25.201	3.1.0	4.0.0
14/12/01	RAN_14	RP-010735	008	-	Removal of slow power control and ODMA from TS 25.201	4.0.0	4.1.0
08/03/02	RAN_15	RP-020231	010	1	Removal of channel coding option "no coding" for FDD	4.1.0	4.2.0
08/03/02	RAN_15	RP-020058	013	-	Specification of HS-DSCH for Release 5 in 25.201	4.1.0	5.0.0
07/06/02	RAN_16	RP-020306	017	-	Downlink bit mapping	5.0.0	5.1.0
10/09/02	RAN_17	RP-020580	018	-	Correction on the description of TS and layer	5.1.0	5.2.0
13/01/04	RAN_22	-	-	-	Created for M.1457 update	5.2.0	6.0.0
13/12/04	RAN_26	RP-040449	019	-	Introduction of E-DCH	6.0.0	6.1.0
16/06/05	RAN_28	RP-050250	021	-	Feature Clean Up: Removal of "CPCH"	6.1.0	6.2.0
20/03/06	RAN_31	RP-060079	0023	-	Introduction of 7.68Mcps TDD option	6.2.0	7.0.0
29/09/06	RAN_33	RP-060492	0025	-	Introduction of E-DCH for 3.84Mcps and 7.68Mcps TDD	7.0.0	7.1.0
07/03/07	RAN_35	RP-070115	031	-	Introduction of CPC related functionality	7.1.0	7.2.0
07/03/07	RAN_35	RP-070114	032	-	Introduction of MIMO	7.1.0	7.2.0
07/03/07	RAN_35	RP-070118	028	-	Introduction of E-DCH for 1.28Mcps TDD	7.1.0	7.2.0
07/03/07	RAN_35	RP-070116	026	2	Introduction of 64QAM for HSDPA	7.1.0	7.2.0
30/05/07	RAN_36	RP-070388	027	2	Introduction of 16QAM for HSUPA	7.2.0	7.3.0
30/05/07	RAN_36	RP-070385	029	1	Support for MBSFN operation	7.2.0	7.3.0
30/05/07	RAN_36	RP-070384	030	1	Support for DL only SFN operation for MBMS FDD	7.2.0	7.3.0
30/05/07	RAN_36	RP-070386	034	-	Support for 1.28Mcps TDD MBSFN operation	7.2.0	7.3.0
11/09/07	RAN_37	RP-070640	0035	1	Minor modification related to EDCH in 1.28Mcps TDD	7.3.0	7.4.0
27/11/07	RAN_38	RP-070943	0037	1	More improvement on dedicated carrier for 1.28Mcps TDD MBMS	7.4.0	7.5.0
04/03/08	RAN_39	-	-	-	Release 8 version created further to RAN_39 decision	7.5.0	8.0.0
28/05/08	RAN_40	RP-080356	0039	-	Introduction 64QAM for 1.28Mcps TDD HSDPA	8.0.0	8.1.0
18/09/09	RAN_45	-	-	-	Release 9 version created further to RAN_45 decision	8.1.0	9.0.0
21/03/11	SP-51	-	-	-	Release 10 version created further to SP-51 decision	9.0.0	10.0.0
2012-09	SP-57	-	-	-	Update to Rel-11 version (MCC)	10.0.0	11.0.0
04/12/12	RAN_58	RP-121845	0040	-	Introduction of uplink MIMO and 64QAM	11.0.0	11.1.0