

3GPP TS 25.142 V11.3.0 (2013-07)

Technical Specification

3rd Generation Partnership Project; Technical Specification Group Radio Access Network; Base Station (BS) conformance testing (TDD) (Release 11)



The present document has been developed within the 3rd Generation Partnership Project (3GPP™) and may be further elaborated for the purposes of 3GPP.

The present document has not been subject to any approval process by the 3GPP Organizational Partners and shall not be implemented. This Specification is provided for future development work within 3GPP only. The Organizational Partners accept no liability for any use of this Specification. Specifications and reports for implementation of the 3GPP™ system should be obtained via the 3GPP Organizational Partners' Publications Offices.

Keywords

UMTS, radio, base station, testing, TDM

3GPP

Postal address

3GPP support office address

650 Route des Lucioles - Sophia Antipolis
Valbonne - FRANCE
Tel.: +33 4 92 94 42 00 Fax: +33 4 93 65 47 16

Internet

<http://www.3gpp.org>

Copyright Notification

No part may be reproduced except as authorized by written permission.
The copyright and the foregoing restriction extend to reproduction in all media.

© 2013, 3GPP Organizational Partners (ARIB, ATIS, CCSA, ETSI, TTA, TTC).
All rights reserved.

UMTS™ is a Trade Mark of ETSI registered for the benefit of its members
3GPP™ is a Trade Mark of ETSI registered for the benefit of its Members and of the 3GPP Organizational Partners
LTE™ is a Trade Mark of ETSI currently being registered for the benefit of its Members and of the 3GPP Organizational Partners
GSM® and the GSM logo are registered and owned by the GSM Association

Contents

Foreword	17
1 Scope	18
2 References.....	18
3 Definitions, symbols, and abbreviations	19
3.1 Definitions	19
3.2 Symbols.....	20
3.3 Abbreviations.....	20
4 Frequency bands and channel arrangement	21
4.1 General	21
4.2 Frequency bands.....	21
4.3 TX-RX frequency separation	21
4.3.1 3,84 Mcps TDD option	21
4.3.2 1,28 Mcps TDD option	21
4.3.3 7,68 Mcps TDD option	21
4.4 Channel arrangement	22
4.4.1 Channel spacing	22
4.4.1.1 3,84 Mcps TDD option	22
4.4.1.2 1,28 Mcps TDD option	22
4.4.1.3 7,68 Mcps TDD option	22
4.4.2 Channel raster	22
4.4.2.1 3,84 Mcps TDD Option	22
4.4.3 Channel number	22
5 General test conditions and declarations	22
5.1 Base station classes	23
5.1.1 Applicability of requirements and BS class definition	23
5.1.2 Manufacturer's declaration.....	23
5.2 Output power.....	23
5.3 Specified frequency range.....	23
5.4 Relationship between RF generation and chip clock	24
5.5 Spectrum emission mask.....	24
5.6 Adjacent Channel Leakage power Ratio (ACLR)	24
5.7 Tx spurious emissions.....	24
5.7.1 Category of spurious emissions limit.....	24
5.7.2 Co-existence with GSM	24
5.7.3 Co-existence with DCS 1800.....	25
5.7.4 Co-existence with UTRA FDD.....	25
5.7.5 Co-existence with unsynchronised UTRA TDD and/or E-UTRA TDD	25
5.8 Blocking characteristics	25
5.9 Test environments	26
5.9.1 Normal test environment.....	26
5.9.2 Extreme test environment.....	26
5.9.2.1 Extreme temperature	26
5.9.3 Vibration.....	27
5.9.4 Power supply.....	27
5.10 Acceptable uncertainty of Test System	27
5.10.1 Measurement of test environments	27
5.10.2 Measurement of transmitter.....	28
5.10.3 Measurement of receiver.....	32
5.10.4 Measurement of performance requirements	33
5.11 Test Tolerances (informative)	33
5.11.1 Transmitter	34
5.11.2 Receiver	36
5.11.3 Performance requirements.....	36
5.12 Interpretation of measurement results.....	36

5.13	Selection of configurations for testing	36
5.14	BS Configurations	37
5.14.1	Receiver diversity	37
5.14.2	Duplexers	37
5.14.3	Power supply options	37
5.14.4	Ancillary RF amplifiers	37
5.14.5	BS using antenna arrays	38
5.14.5.1	Receiver tests	38
5.14.5.2	Transmitter tests	38
5.14.6	MIMO transmission	39
5.15	Overview of the conformance test requirements	39
5.16	Format and interpretation of tests	41
5.17	Regional requirements	41
5.18	Definition of Additive White Gaussian Noise (AWGN) Interferer	42
5.19	Applicability of requirements	42
6	Transmitter characteristics	43
6.1	General	43
6.1.1	IMB Test Models	43
6.1.1.1	IMB Test Model 1	43
6.1.1.2	IMB Test Model 2	44
6.2	Maximum output power	44
6.2.1	Definition and applicability	44
6.2.2	Minimum Requirements	44
6.2.3	Test purpose	45
6.2.4	Method of test	45
6.2.4.1	Initial conditions	45
6.2.4.1.0	General test conditions	45
6.2.4.1.1	3,84 Mcps TDD option	45
6.2.4.1.2	1,28 Mcps TDD option	45
6.2.4.1.3	7,68 Mcps TDD option	46
6.2.4.2	Procedure	46
6.2.4.2.1	3,84 Mcps TDD option	46
6.2.4.2.2	1,28 Mcps TDD option	46
6.2.4.2.3	7,68 Mcps TDD option	46
6.2.5	Test Requirements	47
6.3	Frequency stability	47
6.3.1	Definition and applicability	47
6.3.2	Minimum Requirements	47
6.3.3	Test purpose	47
6.3.4	Method of test	47
6.3.4.1	Initial conditions	47
6.3.4.1.0	General test conditions	47
6.3.4.1.1	3,84 Mcps TDD option	48
6.3.4.1.2	1,28 Mcps TDD option	48
6.3.4.1.3	7,68 Mcps TDD option	48
6.3.4.2	Procedure	49
6.3.5	Test Requirements	49
6.4	Output power dynamics	49
6.4.1	Inner loop power control	49
6.4.2	Power control steps	49
6.4.2.1	Definition and applicability	49
6.4.2.2	Minimum Requirements	50
6.4.2.3	Test purpose	50
6.4.2.4	Method of test	50
6.4.2.4.1	Initial conditions	50
6.4.2.4.1.0	General test conditions	50
6.4.2.4.1.1	3,84 Mcps TDD option	50
6.4.2.4.1.2	1,28 Mcps TDD option	51
6.4.2.4.1.3	7,68 Mcps TDD option	51
6.4.2.4.2	Procedure	52
6.4.2.4.2.1	3,84 Mcps TDD option	52

6.4.2.4.2.2	1,28 Mcps TDD option	52
6.4.2.4.2.3	7,68 Mcps TDD option	52
6.4.2.5	Test Requirements	53
6.4.2.5.1	3,84 Mcps TDD option	53
6.4.2.5.2	1,28 Mcps TDD option	53
6.4.2.5.3	7,68 Mcps TDD option	53
6.4.3	Power control dynamic range	54
6.4.3.1	Definition and applicability	54
6.4.3.2	Minimum Requirements	54
6.4.3.3	Test purpose	54
6.4.3.4	Method of test	54
6.4.3.4.1	Initial conditions	54
6.4.3.4.1.0	General test conditions	54
6.4.3.4.1.1	3,84 Mcps TDD option	54
6.4.3.4.1.2	1,28 Mcps TDD option	55
6.4.3.4.1.3	7,68 Mcps TDD option	55
6.4.3.4.2	Procedure	56
6.4.3.4.2.1	3,84 Mcps TDD option	56
6.4.3.4.2.2	1,28 Mcps TDD option	56
6.4.3.4.2.3	7,68 Mcps TDD option	57
6.4.3.5	Test Requirements	57
6.4.4	Minimum output power	57
6.4.4.1	Definition and applicability	57
6.4.4.2	Minimum Requirements	57
6.4.4.3	Test purpose	57
6.4.4.4	Method of test	57
6.4.4.4.1	Initial conditions	57
6.4.4.4.1.0	General test conditions	57
6.4.4.4.1.1	3,84 Mcps TDD option	58
6.4.4.4.1.2	1,28 Mcps TDD option	58
6.4.4.4.1.3	7,68 Mcps TDD option	58
6.4.4.4.2	Procedure	59
6.4.4.4.2.1	3,84 Mcps TDD option	59
6.4.4.4.2.2	1,28 Mcps TDD option	59
6.4.4.4.2.3	7,68 Mcps TDD option	59
6.4.4.5	Test Requirements	60
6.4.5	Primary CCPCCH power	60
6.4.5.1	Definition and applicability	60
6.4.5.2	Minimum Requirements	60
6.4.5.3	Test purpose	60
6.4.5.4	Method of test	61
6.4.5.4.1	Initial conditions	61
6.4.5.4.1.0	General test conditions	61
6.4.5.4.1.1	3,84 Mcps TDD option	61
6.4.5.4.1.2	1,28 Mcps TDD option	61
6.4.5.4.1.3	7,68 Mcps TDD option	61
6.4.5.4.2	Procedure	62
6.4.5.4.2.1	3,84 Mcps TDD option	62
6.4.5.4.2.2	1,28 Mcps TDD option	62
6.4.5.4.2.3	7,68 Mcps TDD option	62
6.4.5.5	Test Requirements	62
6.4.6	Differential accuracy of Primary CCPCCH power	63
6.4.6.1	Definition and applicability	63
6.4.6.2	Minimum Requirements	63
6.4.6.3	Test purpose	63
6.4.6.4	Method of test	63
6.4.6.4.1	Initial conditions	63
6.4.6.4.1.0	General test conditions	63
6.4.6.4.1.1	3,84 Mcps TDD option	63
6.4.6.4.1.2	1,28 Mcps TDD option	64
6.4.6.4.1.3	7,68 Mcps TDD option	64
6.4.6.4.2	Procedure	64

6.4.6.4.2.1	3,84 Mcps TDD option	64
6.4.6.4.2.2	1,28 Mcps TDD option	64
6.4.6.4.2.3	7,68 Mcps TDD option	65
6.4.6.5	Test Requirements	65
6.5	Transmit ON/OFF power	65
6.5.1	Transmit OFF power	65
6.5.1.1	Definition and applicability	65
6.5.1.2	Minimum Requirements	65
6.5.1.2.1	3,84 Mcps TDD option	65
6.5.1.2.2	1,28 Mcps TDD option	65
6.5.1.2.3	7,68 Mcps TDD option	65
6.5.1.3	Test purpose.....	65
6.5.1.4	Method of test.....	65
6.5.1.4.1	Initial conditions	65
6.5.1.4.2	Procedure.....	66
6.5.1.5	Test Requirements	66
6.5.2	Transmit ON/OFF time mask.....	66
6.5.2.1	Definition and applicability	66
6.5.2.2	Minimum Requirements	66
6.5.2.2.1	3,84 Mcps TDD option	66
6.5.2.2.2	1,28 Mcps TDD option	66
6.5.2.2.3	7,68 Mcps TDD option	67
6.5.2.3	Test purpose.....	67
6.5.2.4	Method of test.....	67
6.5.2.4.1	Initial conditions	67
6.5.2.4.1.0	General test conditions	67
6.5.2.4.1.1	3,84 Mcps TDD option	68
6.5.2.4.1.2	1,28 Mcps TDD option	68
6.5.2.4.1.3	7,68 Mcps TDD option	68
6.5.2.4.2	Procedure.....	69
6.5.2.4.2.1	3,84 Mcps TDD option	69
6.5.2.4.2.2	1,28 Mcps TDD option	69
6.5.2.4.2.3	7,68 Mcps TDD option	69
6.5.2.5	Test Requirements	69
6.5.2.5.1	3,84 Mcps TDD option	69
6.5.2.5.2	1,28 Mcps TDD option	69
6.5.2.5.3	7,68 Mcps TDD option	69
6.6	Output RF spectrum emissions	69
6.6.1	Occupied bandwidth	69
6.6.1.1	Definition and applicability	69
6.6.1.2	Minimum Requirements	69
6.6.1.2.1	3,84 Mcps TDD option	69
6.6.1.2.2	1,28 Mcps TDD option	70
6.6.1.2.3	7,68 Mcps TDD option	70
6.6.1.3	Test purpose.....	70
6.6.1.4	Method of test.....	70
6.6.1.4.1	Initial conditions	70
6.6.1.4.1.0	General test conditions	70
6.6.1.4.1.1	3,84 Mcps TDD option	70
6.6.1.4.1.2	1,28 Mcps TDD option	70
6.6.1.4.1.3	7,68 Mcps TDD option	71
6.6.1.4.2	Procedure.....	71
6.6.1.4.2.1	3,84 Mcps TDD option	71
6.6.1.4.2.2	1,28 Mcps TDD option	71
6.6.1.4.2.3	7,68 Mcps TDD option	72
6.6.1.5	Test Requirements	72
6.6.1.5.1	3,84 Mcps TDD option	72
6.6.1.5.2	1,28 Mcps TDD option	72
6.6.1.5.3	7,68 Mcps TDD option	72
6.6.2	Out of band emission.....	73
6.6.2.1	Spectrum emission mask.....	73
6.6.2.1.1	Definition and applicability	73

6.6.2.1.1.1	3,84 Mcps TDD option	73
6.6.2.1.1.2	1,28 Mcps TDD option	73
6.6.2.1.1.3	7,68 Mcps TDD option	73
6.6.2.1.2	Minimum Requirements	73
6.6.2.1.2.1	3,84 Mcps TDD option	73
6.6.2.1.2.2	1,28 Mcps TDD option	74
6.6.2.1.2.3	7,68 Mcps TDD option	75
6.6.2.1.3	Test purpose.....	76
6.6.2.1.4	Method of test.....	77
6.6.2.1.4.1	Initial conditions	77
6.6.2.1.4.1.0	General test conditions	77
6.6.2.1.4.1.1	3,84 Mcps TDD option - General test set up.....	77
6.6.2.1.4.1.2	1,28 Mcps TDD option - General test set up.....	77
6.6.2.1.4.1.3	1,28 Mcps TDD option - Special test set up for 16QAM capable BS	77
6.6.2.1.4.1.4	3,84 Mcps TDD option - Special test set up for 16QAM capable BS	78
6.6.2.1.4.1.5	7,68 Mcps TDD option - General test set up.....	78
6.6.2.1.4.1.6	7,68 Mcps TDD option - Special test set up for 16QAM capable BS	79
6.6.2.1.4.2	Procedure	79
6.6.2.1.4.2.1	3,84 Mcps TDD option	79
6.6.2.1.4.2.2	1,28 Mcps TDD option	79
6.6.2.1.4.2.3	1,28 Mcps TDD option - 16QAM capable BS	80
6.6.2.1.4.2.4	3,84 Mcps TDD option - 16QAM capable BS	80
6.6.2.1.4.2.5	7,68 Mcps TDD option	80
6.6.2.1.4.2.6	7,68 Mcps TDD option - 16QAM capable BS	80
6.6.2.1.5	Test Requirements	80
6.6.2.1.5.1	3,84 Mcps TDD option	80
6.6.2.1.5.2	1,28 Mcps TDD option	81
6.6.2.1.5.3	1,28 Mcps TDD option - 16QAM capable BS	82
6.6.2.1.5.4	3,84 Mcps TDD option - 16QAM capable BS	82
6.6.2.1.5.5	7,68 Mcps TDD option	82
6.6.2.1.5.6	7,68 Mcps TDD option - 16QAM capable BS	83
6.6.2.2	Adjacent Channel Leakage power Ratio (ACLR).....	83
6.6.2.2.1	Definition and applicability	83
6.6.2.2.2	Minimum Requirements	84
6.6.2.2.2.1	Minimum requirement	84
6.6.2.2.2.1.1	3,84 Mcps TDD option	84
6.6.2.2.2.1.2	1,28 Mcps TDD option	84
6.6.2.2.2.1.3	7,68 Mcps TDD option	84
6.6.2.2.2.2	Void	85
6.6.2.2.2.2.1	Void	85
6.6.2.2.2.2.1.1	Void	85
6.6.2.2.2.2.1.2	Void	85
6.6.2.2.2.2.2	Void	85
6.6.2.2.2.2.2.1	Void	85
6.6.2.2.2.2.2.2	Void	85
6.6.2.2.2.2.3	Void	85
6.6.2.2.2.2.3.1	Void	85
6.6.2.2.2.2.3.2	Void	85
6.6.2.2.2.3	Void	85
6.6.2.2.2.3.1	Void	85
6.6.2.2.2.3.1.1	Void	85
6.6.2.2.2.3.1.2	Void	85
6.6.2.2.2.3.2	Void	85
6.6.2.2.2.3.2.1	Void	85
6.6.2.2.2.3.2.2	Void	85
6.6.2.2.2.3.3	Void	85
6.6.2.2.2.3.3.1	Void	85
6.6.2.2.2.3.3.2	Void	85
6.6.2.2.3	Test purpose.....	85
6.6.2.2.4	Method of test.....	85
6.6.2.2.4.1	Initial conditions	85
6.6.2.2.4.1.0	General test conditions	86

6.6.2.2.4.1.1	3,84 Mcps TDD option - General test set up.....	86
6.6.2.2.4.1.2	1,28 Mcps TDD option - General test set up.....	86
6.6.2.2.4.1.3	1,28 Mcps TDD option - Special test set up for 16QAM capable BS	86
6.6.2.2.4.1.4	3,84 Mcps TDD option - Special test set up for 16QAM capable BS	87
6.6.2.2.4.1.5	7,68 Mcps TDD option - General test set up.....	87
6.6.2.2.4.1.6	7,68 Mcps TDD option - Special test set up for 16QAM capable BS	88
6.6.2.2.4.2	Procedure	88
6.6.2.2.4.2.1	3,84 Mcps TDD option	88
6.6.2.2.4.2.2	1,28 Mcps TDD option	89
6.6.2.2.4.2.3	1,28 Mcps TDD option - 16QAM capable BS	89
6.6.2.2.4.2.4	3,84 Mcps TDD option - 16QAM capable BS	89
6.6.2.2.4.2.5	7,68 Mcps TDD option	89
6.6.2.2.4.2.6	7,68 Mcps TDD option - 16QAM capable BS	90
6.6.2.2.5	Test Requirements	90
6.6.2.2.5.1	3,84 Mcps TDD option	90
6.6.2.2.5.2	1,28 Mcps TDD option	90
6.6.2.2.5.3	1,28 Mcps TDD option - 16QAM capable BS	90
6.6.2.2.5.4	3,84 Mcps TDD option - 16QAM capable BS	91
6.6.2.2.5.5	7,68 Mcps TDD option	91
6.6.2.2.5.6	7,68 Mcps TDD option - 16QAM capable BS	91
6.6.3	Spurious emissions.....	91
6.6.3.1	Definition and applicability.....	91
6.6.3.2	Minimum Requirements	91
6.6.3.2.1	Mandatory requirements.....	91
6.6.3.2.1.1	Spurious emissions (Category A)	91
6.6.3.2.1.1.1	3,84 Mcps TDD option	92
6.6.3.2.1.1.2	1,28 Mcps TDD option	92
6.6.3.2.1.1.3	7,68 Mcps TDD option	92
6.6.3.2.1.2	Spurious emissions (Category B)	92
6.6.3.2.1.2.1	3,84 Mcps TDD option	92
6.6.3.2.1.2.2	1,28 Mcps TDD option	93
6.6.3.2.1.2.3	7,68 Mcps TDD option	93
6.6.3.2.2	Co-existence with GSM, DCS, UTRA and/or E-UTRA.....	94
6.6.3.2.2.1	Operation in the same geographic area	94
6.6.3.2.2.2	Co-located base stations.....	96
6.6.3.2.3	(void).....	98
6.6.3.2.3.1	(void)	98
6.6.3.2.3.2	Void	98
6.6.3.2.4	Void.....	98
6.6.3.2.5	Co-existence with unsynchronised UTRA TDD and/or E-UTRA TDD.....	98
6.6.3.2.5.1	Operation in the same geographic area	98
6.6.3.2.5.1.1	3,84 Mcps TDD option	98
6.6.3.2.5.1.2	1,28 Mcps TDD option	99
6.6.3.2.5.1.3	7,68 Mcps TDD option	99
6.6.3.2.5.2	Co-located base stations.....	100
6.6.3.2.5.2.1	3,84 Mcps TDD option	100
6.6.3.2.5.2.2	1,28 Mcps TDD option	101
6.6.3.2.5.2.3	7,68 Mcps TDD option	102
6.6.3.2.6	Co-existence with PHS	103
6.6.3.2.6.1	3,84 Mcps TDD option	103
6.6.3.2.6.2	(void)	104
6.6.3.2.6.3	7,68 Mcps TDD option	104
6.6.3.3	Test purpose.....	104
6.6.3.3.1	3,84 Mcps TDD option	104
6.6.3.3.2	1,28 Mcps TDD option	104
6.6.3.3.3	7,68 Mcps TDD option	104
6.6.3.4	Method of test.....	104
6.6.3.4.1	Initial conditions	104
6.6.3.4.1.0	General test conditions	105
6.6.3.4.1.1	3,84 Mcps TDD option - General test set up.....	105
6.6.3.4.1.2	1,28 Mcps TDD option - General test set up.....	105
6.6.3.4.1.3	1,28 Mcps TDD option - Special test set up for 16QAM capable BS	105

6.6.3.4.1.4	3,84 Mcps TDD option - Special test set up for 16QAM capable BS	106
6.6.3.4.1.5	7,68 Mcps TDD option - General test set up	106
6.6.3.4.1.6	7,68 Mcps TDD option - Special test set up for 16QAM capable BS	107
6.6.3.4.2	Procedure.....	107
6.6.3.5	Test Requirements	107
6.7	Transmit intermodulation	107
6.7.1	Definition and applicability	107
6.7.1.1	3,84 Mcps TDD option	108
6.7.1.2	1,28 Mcps TDD option	108
6.7.1.3	7,68 Mcps TDD option	108
6.7.2	Minimum Requirements	108
6.7.3	Test purpose.....	108
6.7.4	Method of test.....	108
6.7.4.1	Initial conditions	108
6.7.4.1.0	General test conditions.....	108
6.7.4.1.1	3,84 Mcps TDD option - General test set up	109
6.7.4.1.2	1,28 Mcps TDD option - General test set up	109
6.7.4.1.3	1,28 Mcps TDD option - Special test set up for 16QAM capable BS	110
6.7.4.1.4	3,84 Mcps TDD option - Special test set up for 16QAM capable BS	111
6.7.4.1.5	7,68 Mcps TDD option - General test set up	112
6.7.4.1.6	7,68 Mcps TDD option - Special test set up for 16QAM capable BS	113
6.7.4.2	Procedure.....	114
6.7.5	Test Requirements.....	114
6.8	Transmit Modulation	114
6.8.1	Modulation accuracy	114
6.8.1.1	Definition and applicability	114
6.8.1.2	Minimum Requirements	114
6.8.1.3	Test purpose.....	115
6.8.1.4	Method of test.....	115
6.8.1.4.1	Initial conditions	115
6.8.1.4.1.0	General test conditions	115
6.8.1.4.1.1	3,84 Mcps TDD option - General test setup	115
6.8.1.4.1.2	1,28 Mcps TDD option - General test set up.....	115
6.8.1.4.1.3	1,28 Mcps TDD option - Special test set up for 16QAM capable BS	116
6.8.1.4.1.4	3,84 Mcps TDD option - Special test set up for 16QAM capable BS	116
6.8.1.4.1.5	7,68 Mcps TDD option - General test setup	116
6.8.1.4.1.6	7,68 Mcps TDD option - Special test set up for 16QAM capable BS	117
6.8.1.4.2	Procedure.....	117
6.8.1.4.2.1	3,84 Mcps TDD option - General procedure	117
6.8.1.4.2.2	1,28 Mcps TDD option - General procedure	118
6.8.1.4.2.3	1,28 Mcps TDD option - Special procedure for 16QAM capable BS	118
6.8.1.4.2.4	3,84 Mcps TDD option - Special test set up for 16QAM capable BS	119
6.8.1.4.2.5	7,68 Mcps TDD option - General procedure	119
6.8.1.4.2.6	7,68 Mcps TDD option - Special test set up for 16QAM capable BS	119
6.8.1.5	Test Requirements	120
6.8.2	Peak code domain error.....	120
6.8.2.1	Definition and applicability.....	120
6.8.2.2	Minimum Requirements	120
6.8.2.3	Test purpose.....	120
6.8.2.4	Method of test.....	120
6.8.2.4.1	Initial conditions	120
6.8.2.4.1.0	General test conditions	121
6.8.2.4.1.1	3,84 Mcps TDD option - General test set up.....	121
6.8.2.4.1.2	1,28 Mcps TDD option - General test set up	121
6.8.2.4.1.3	1,28 Mcps TDD option - Special test set up for 16QAM capable BS	121
6.8.2.4.1.4	3,84 Mcps TDD option - Special test set up for 16QAM capable BS	122
6.8.2.4.1.5	7,68 Mcps TDD option - General test set up.....	122
6.8.2.4.1.6	7,68 Mcps TDD option - Special test set up for 16QAM capable BS	123
6.8.2.4.2	Procedure.....	123
6.8.2.5	Test Requirements	123
6.8.3	Relative Code Domain Error.....	123
6.8.3.1	Definition and applicability.....	123

6.8.3.2	Minimum requirement	123
6.8.3.3	Test Purpose.....	123
6.8.3.4	Method of test.....	124
6.8.3.4.1	Initial conditions	124
6.8.3.4.1.0	General test conditions	124
6.8.3.4.1.1	1.28 Mcps TDD option- General test set up	124
6.8.3.4.1.2	1.28 Mcps TDD option - Special test set up for 64QAM capable BS	124
6.8.3.4.2	Procedure.....	124
6.8.3.5	Test Requirements	125
6.8.4	Time alignment error in MIMO transmission	125
6.8.4.1	Definition and applicability.....	125
6.8.4.2	Minimum requirement	125
6.8.4.3	Test Purpose.....	125
6.8.4.4	Method of test.....	125
6.8.4.4.1	Initial conditions	125
6.8.4.4.1.0	General test conditions	125
6.8.4.4.1.1	1.28 Mcps TDD option- General test set up	125
6.8.4.4.2	Procedure.....	126
6.8.4.4.2.1	1.28 Mcps TDD option	126
6.8.4.5	Test Requirements	126
6.8.4.5.1	1.28 Mcps TDD option	126
7	Receiver characteristics	126
7.1	General	126
7.2	Reference sensitivity level	127
7.2.1	Definition and applicability	127
7.2.2	Minimum Requirements	127
7.2.2.1	3,84 Mcps TDD option	127
7.2.2.2	1,28 Mcps option	127
7.2.2.3	7,68 Mcps TDD option	128
7.2.3	Test purpose.....	128
7.2.4	Method of test.....	128
7.2.4.1	Initial conditions	128
7.2.4.1.0	General test requirements	128
7.2.4.1.1	3,84 Mcps TDD option	128
7.2.4.1.2	1,28 Mcps TDD option	128
7.2.4.1.3	7,68 Mcps TDD option	129
7.2.4.2	Procedure.....	129
7.2.5	Test Requirements.....	129
7.2.5.1	3,84 Mcps TDD option	129
7.2.5.2	1,28 Mcps TDD option	129
7.2.5.3	7,68 Mcps TDD option	130
7.3	Dynamic range	130
7.3.1	Definition and applicability	130
7.3.2	Minimum Requirements	130
7.3.2.1	3,84 Mcps TDD option	130
7.3.2.2	1,28 Mcps TDD option	130
7.3.2.3	7,68 Mcps TDD option	131
7.3.3	Test purpose.....	131
7.3.4	Method of test.....	131
7.3.4.1	Initial conditions	131
7.3.4.1.0	General test conditions.....	131
7.3.4.1.1	3,84 Mcps TDD option	131
7.3.4.1.2	1,28 Mcps TDD option	131
7.3.4.1.3	7,68 Mcps TDD option	132
7.3.4.2	Procedure.....	132
7.3.5	Test Requirements.....	132
7.3.5.1	3,84 Mcps TDD option	132
7.3.5.2	1,28 Mcps TDD option	132
7.3.5.3	7,68 Mcps TDD option	133
7.4	Adjacent Channel Selectivity (ACS).....	133
7.4.1	Definition and applicability	133

7.4.2	Minimum Requirements	133
7.4.2.1	3,84 Mcps TDD option	133
7.4.2.2	1,28 Mcps TDD option	134
7.4.2.3	7,68 Mcps TDD option	134
7.4.3	Test purpose.....	134
7.4.4	Method of test.....	134
7.4.4.1	Initial conditions	134
7.4.4.1.0	General test conditions.....	134
7.4.4.1.1	3,84 Mcps TDD option	135
7.4.4.1.2	1,28 Mcps TDD option	135
7.4.4.1.3	7,68 Mcps TDD option	135
7.4.4.2	Procedure.....	135
7.4.4.2.1	3,84 Mcps TDD option	135
7.4.4.2.2	1,28 Mcps TDD option	136
7.4.4.2.3	7,68 Mcps TDD option	136
7.4.5	Test Requirements.....	136
7.5	Blocking characteristics	136
7.5.1	Definition and applicability	136
7.5.1.1	3,84 Mcps TDD option	136
7.5.1.2	1,28 Mcps TDD option	136
7.5.1.3	7,68 Mcps TDD option	137
7.5.2	Minimum Requirements	137
7.5.2.1	3,84 Mcps TDD option	137
7.5.2.1.1	General requirements	137
7.5.2.1.2	Co-location with GSM, DCS, UTRA-FDD and/or E-UTRA FDD	139
7.5.2.1.3	Void	140
7.5.2.2	1,28 Mcps TDD option	140
7.5.2.2.1	General requirements	140
7.5.2.2.2	Co-location with GSM, DCS, UTRA FDD and/or E-UTRA FDD, UTRA TDD and/or E-UTRA TDD	143
7.5.2.2.3	Void	146
7.5.2.3	7,68 Mcps TDD option	146
7.5.2.3.1	General requirements	146
7.5.2.3.2	Void	148
7.5.2.3.3	Void	148
7.5.2.3.4	Co-location with GSM, DCS, UTRA-FDD and/or E-UTRA FDD	148
7.5.3	Test purpose.....	149
7.5.3.1	3,84 Mcps TDD option	149
7.5.3.2	1,28 Mcps TDD option	149
7.5.3.3	7,68 Mcps TDD option	149
7.5.4	Method of test.....	149
7.5.4.1	Initial conditions	149
7.5.4.2	Procedure.....	150
7.5.4.2.1	3,84 Mcps TDD option	150
7.5.4.2.2	1,28 Mcps TDD option	150
7.5.4.2.3	7,68 Mcps TDD option	150
7.5.5	Test Requirements.....	151
7.6	Intermodulation characteristics	151
7.6.1	Definition and applicability	151
7.6.2	Minimum Requirements	151
7.6.2.1	3,84 Mcps TDD option	151
7.6.2.2	1,28 Mcps TDD option	151
7.6.2.3	7,68 Mcps TDD option	152
7.6.3	Test purpose.....	152
7.6.4	Method of test.....	152
7.6.4.1	Initial conditions	152
7.6.4.1.1	3,84 Mcps TDD option	152
7.6.4.1.2	1,28 Mcps TDD option	153
7.6.4.1.3	7,68 Mcps TDD option	153
7.6.4.2	Procedure.....	153
7.6.4.2.1	3,84 Mcps TDD option	153
7.6.4.2.2	1,28 Mcps TDD option	153

7.6.4.2.3	7,68 Mcps TDD option	154
7.6.5	Test Requirements.....	154
7.7	Spurious emissions.....	154
7.7.1	Definition and applicability	154
7.7.2	Minimum Requirements	154
7.7.2.1	3,84 Mcps TDD option	154
7.7.2.2	1,28 Mcps TDD option	155
7.7.2.3	7,68 Mcps TDD option	156
7.7.3	Test purpose.....	157
7.7.4	Method of test.....	157
7.7.4.1	Initial conditions	157
7.7.4.1.0	General test conditions.....	157
7.7.4.1.1	3,84 Mcps TDD option	157
7.7.4.1.2	1,28 Mcps TDD option	157
7.7.4.1.3	7,68 Mcps TDD option	158
7.7.4.2	Procedure.....	158
7.7.4.2.1	3,84 Mcps TDD option	158
7.7.4.2.2	1,28 Mcps TDD option	159
7.7.4.2.3	7,68 Mcps TDD option	159
7.7.5	Test Requirements.....	160
8	Performance requirements	160
8.1	General	160
8.2	Demodulation in static propagation conditions.....	161
8.2.1	Demodulation of DCH	161
8.2.1.1	Definition and applicability.....	161
8.2.1.2	Minimum Requirements	161
8.2.1.2.1	3,84 Mcps TDD option	161
8.2.1.2.2	1,28 Mcps TDD option	162
8.2.1.2.3	7,68 Mcps TDD option	162
8.2.1.3	Test purpose.....	163
8.2.1.4	Method of test.....	163
8.2.1.4.1	Initial conditions	163
8.2.1.4.1.0	General test conditions	163
8.2.1.4.1.1	3,84 Mcps TDD option	163
8.2.1.4.1.2	1,28 Mcps TDD option	163
8.2.1.4.1.3	7,68 Mcps TDD option	164
8.2.1.4.2	Procedure.....	164
8.2.1.4.2.1	3,84 Mcps TDD option	164
8.2.1.4.2.2	1,28 Mcps TDD option	164
8.2.1.4.2.3	7,68 Mcps TDD option	165
8.2.1.5	Test Requirements	165
8.2.1.5.1	3,84 Mcps TDD option	166
8.2.1.5.2	1,28 Mcps TDD option	166
8.2.1.5.3	7,68 Mcps TDD option	166
8.3	Demodulation of DCH in multipath fading conditions.....	166
8.3.1	Multipath fading Case 1	166
8.3.1.1	Definition and applicability.....	166
8.3.1.2	Minimum Requirements	166
8.3.1.2.1	3,84 Mcps TDD option	166
8.3.1.2.2	1,28 Mcps TDD option	167
8.3.1.2.3	7,68 Mcps TDD option	167
8.3.1.3	Test purpose.....	168
8.3.1.4	Method of test.....	168
8.3.1.4.1	Initial conditions	168
8.3.1.4.1.0	General test conditions	168
8.3.1.4.1.1	3,84 Mcps TDD option	168
8.3.1.4.1.2	1,28 Mcps TDD option	169
8.3.1.4.1.3	7,68 Mcps TDD option	169
8.3.1.4.2	Procedure.....	169
8.3.1.4.2.1	3,84 Mcps TDD option	169
8.3.1.4.2.2	1,28 Mcps TDD option	170

8.3.1.4.2.3	7,68 Mcps TDD option	170
8.3.1.5	Test Requirements	171
8.3.1.5.1	3,84 Mcps TDD option	171
8.3.1.5.2	1,28 Mcps TDD option	171
8.3.1.5.3	7,68 Mcps TDD option	171
8.3.2	Multipath fading Case 2	171
8.3.2.1	Definition and applicability	171
8.3.2.2	Minimum Requirements	171
8.3.2.2.1	3,84 Mcps TDD option	171
8.3.2.2.2	1,28 Mcps option	172
8.3.2.2.3	7,68 Mcps TDD option	173
8.3.2.3	Test purpose.....	173
8.3.2.4	Method of test.....	173
8.3.2.4.1	Initial conditions	173
8.3.2.4.1.0	General test conditions	173
8.3.2.4.1.1	3,84 Mcps TDD option	173
8.3.2.4.1.2	1,28 Mcps TDD option	174
8.3.2.4.1.3	7,68 Mcps TDD option	174
8.3.2.4.2	Procedure.....	174
8.3.2.4.2.1	3,84 Mcps TDD option	174
8.3.2.4.2.2	1,28 Mcps TDD option	175
8.3.2.4.2.3	7,68 Mcps TDD option	175
8.3.2.5	Test Requirements	176
8.3.2.5.1	3,84 Mcps TDD option	176
8.3.2.5.2	1,28 Mcps TDD option	176
8.3.2.5.3	7,68 Mcps TDD option	176
8.3.3	Multipath fading Case 3	176
8.3.3.1	Definition and applicability	176
8.3.3.2	Minimum Requirements	176
8.3.3.2.1	3,84 Mcps TDD option	176
8.3.3.2.2	1,28 Mcps TDD option	177
8.3.3.2.3	7,68 Mcps TDD option	178
8.3.3.3	Test purpose.....	178
8.3.3.4	Method of test.....	179
8.3.3.4.1	Initial conditions	179
8.3.3.4.1.0	General test conditions	179
8.3.3.4.1.1	3,84 Mcps TDD option	179
8.3.3.4.1.2	1,28 Mcps TDD option	179
8.3.3.4.1.3	7,68 Mcps TDD option	179
8.3.3.4.2	Procedure.....	179
8.3.3.4.2.1	3,84 Mcps TDD option	179
8.3.3.4.2.2	1,28 Mcps TDD option	180
8.3.3.4.2.3	7,68 Mcps TDD option	181
8.3.3.5	Test Requirements	181
8.3.3.5.1	3,84 Mcps TDD option	181
8.3.3.5.2	1,28 Mcps TDD option	181
8.3.3.5.3	7,68 Mcps TDD option	182
8.3A	Demodulation of DCH in high speed train conditions	182
8.3A.1	Definition and applicability	182
8.3A.2	Minimum requirement	182
8.3A.2.1	3.84 Mcps TDD option	182
8.3A.2.2	1.28 Mcps TDD option	182
8.3A.2.3	7.68 Mcps TDD option	183
8.3A.3	Test purpose	183
8.3A.4	Method of test	184
8.3A.4.1	Initial conditions	184
8.3A.4.1.1	General test conditions	184
8.3A.4.1.1	3.84 Mcps TDD option	184
8.3A.4.1.1	1.28 Mcps TDD option	184
8.3A.4.1.1	7.68 Mcps TDD option	184
8.3A.4.2	Procedure	184
8.3A.4.2.1	3.84 Mcps TDD option	184

8.3A.4.2.2	1.28 Mcps TDD option	184
8.3A.4.2.3	7.68 Mcps TDD option	185
8.3A.5	Test requirements	185
8.3A.5.1	3,84 Mcps TDD option	185
8.3A.5.2	1,28 Mcps TDD option	185
8.3A.5.3	7,68 Mcps TDD option	186
8.4	Demodulation of E-DCH FRC in multipath fading conditions	186
8.4.1	Definition and applicability	186
8.4.2	Minimum Requirements	186
8.4.2.1	3,84 Mcps TDD Option	186
8.4.2.2	1.28Mcps TDD option	187
8.4.2.3	7.68 Mcps TDD Option	188
8.4.3	Test purpose.....	188
8.4.4	Method of test.....	188
8.4.4.1	Initial conditions	188
8.4.4.1.0	General test conditions.....	188
8.4.4.1.1	3,84 Mcps TDD option	189
8.4.4.1.2	1.28Mcps TDD option	189
8.4.4.1.3	7.68 Mcps TDD option	189
8.4.4.2	Procedure.....	189
8.4.4.2.1	3,84 Mcps TDD option	189
8.4.4.2.2	1.28Mcps TDD option	190
8.4.4.2.3	7.68 Mcps TDD option	190
8.4.5	Test Requirements.....	191
8.4.5.1	3,84 Mcps TDD option	191
8.4.5.2	1.28Mcps TDD option	191
8.4.5.3	7.68 Mcps TDD option	191
8.5	Performance of ACK error detection for HS-SICH	191
8.5.1	ACK error detection in static propagation conditions.....	191
8.5.1.1	3.84 Mcps TDD option	191
8.5.1.2	1.28 Mcps TDD option	191
8.5.1.2.1	Definition and applicability.....	191
8.5.1.2.2	Minimum requirement	191
8.5.1.2.3	Test purpose.....	193
8.5.1.2.4	Method of test.....	193
8.5.1.2.4.1	Initial conditions	193
8.5.1.2.4.2	Procedure	193
8.5.1.2.5	Test requirements.....	193
8.5.2	ACK error detection in multipath fading conditions.....	194
8.5.2.1	3,84Mcps TDD option	194
8.5.2.2	1,28Mcps TDD option	194
8.5.2.2.1	Definition and applicability.....	194
8.5.2.2.2	Minimum requirement	194
8.5.2.2.3	Test purpose.....	196
8.5.2.2.4	Method of test.....	196
8.5.2.2.4.1	Initial conditions	196
8.5.2.2.4.2	Procedure	196
8.5.2.2.5	Test requirements.....	196
Annex A (normative): Measurement Channels		198
A.1	(void)	198
A.2	Reference measurement channel	198
A.2.1	UL reference measurement channel (12,2 kbps).....	198
A.2.1.1	3,84 Mcps TDD option	198
A.2.1.2	1,28 Mcps option.....	199
A.2.1.3	7,68 Mcps TDD Option.....	200
A.2.2	UL reference measurement channel (64 kbps).....	201
A.2.2.1	3,84 Mcps TDD option	201
A.2.2.2	1,28 Mcps TDD option	203
A.2.2.3	7,68 Mcps TDD Option.....	204
A.2.3	UL reference measurement channel (144 kbps).....	205

A.2.3.1	3,84 Mcps TDD option	205
A.2.3.2	1,28 Mcps TDD option	207
A.2.3.3	7,68 Mcps TDD Option.....	208
A.2.4	UL reference measurement channel (384 kbps).....	209
A.2.4.1	3,84 Mcps TDD option	209
A.2.4.2	1,28 Mcps TDD option	211
A.2.4.3	7,68 Mcps TDD Option.....	212
A.2.5	RACH reference measurement channel.....	213
A.2.5.1	3,84 Mcps TDD option	213
A.2.5.1.1	RACH mapped to 1 code SF16	213
A.2.5.1.2	RACH mapped to 1 code SF8	214
A.2.5.2	1,28 Mcps TDD option	214
A.2.5.2.1	RACH mapped to 1 code SF16	215
A.2.5.2.2	RACH mapped to 1 code SF8	215
A.2.5.2.3	RACH mapped to 1 code SF4	216
A.2.5.3	7,68 Mcps TDD option	216
A.2.5.3.1	RACH mapped to 1 code SF16	217
A.2.5.3.2	RACH mapped to 1 code SF32	217
A.3	E-DCH Reference measurement channels.....	218
A.3.1	E-DCH Fixed Reference Channels	218
A.3.1.1	3,84 Mcps TDD Option.....	218
A.3.1.1.1	Fixed Reference Channel 1 (FRC1)	218
A.3.1.1.2	Fixed Reference Channel 2 (FRC2)	219
A.3.1.1.3	Fixed Reference Channel 3 (FRC3)	219
A.3.1.2	1.28Mcps TDD Option.....	220
A.3.1.2.1	Fixed reference channel 1(FRC1)	220
A.3.1.2.2	Fixed reference channel 2(FRC2)	221
A.3.1.2.3	Fixed reference channel 3(FRC3)	222
A.3.1.2.4	Fixed reference channel 4(FRC4)	223
A.3.1.3	7,68 Mcps TDD Option.....	224
A.3.1.3.1	Fixed Reference Channel 1 (FRC1)	224
A.3.1.3.2	Fixed Reference Channel 2 (FRC2)	225
A.3.1.3.3	Fixed Reference Channel 3 (FRC3)	226
A.4	HS-SICH Reference measurement channels.....	227
A.4.1	3,84 Mcps TDD Option	227
A.4.2	1,28 Mcps TDD Option	227
Annex B (normative):	Propagation conditions	229
B.1	Static propagation condition.....	229
B.2	Multi-path fading propagation conditions.....	229
B.2.1	3,84 Mcps TDD option	229
B.2.2	1,28 Mcps TDD option	229
B.2.3	7,68 Mcps TDD option	230
B.3	High speed train conditions	231
Annex C (normative):	Global in-channel Tx test.....	233
C.1	General.....	233
C.2	Definition of the process.....	233
C.2.1	Basic principle	233
C.2.2	Output signal of the Tx under test	233
C.2.3	Reference signal.....	233
C.2.4	Classification of measurement results.....	234
C.2.5	Process definition to achieve results of type "deviation"	234
C.2.5.1	Decision Point Power	235
C.2.5.2	Code-Domain Power	235
C.2.6	Process definition to achieve results of type "residual"	235
C.2.6.1	Error Vector Magnitude (EVM)	236
C.2.6.2	Peak Code Domain Error (PCDE)	236

C.2.6.3 Relative Code Domain Error (RCDE).....236

C.3 Notes.....237

C.3.1 Symbol length.....237

C.3.2 Deviation.....237

C.3.3 Residual.....237

C.3.4 TDD.....237

C.3.5 Synch channel.....237

C.3.6 Formula for the minimum process.....238

C.3.7 Formula for EVM.....239

Annex D (informative): Derivation of Test Requirements239

Annex E (informative): Acceptable uncertainty of Test Equipment.....246

Annex F (normative): General rules for statistical testing.....248

F.1 Statistical testing of receiver BER/BLER performance248

F.1.1 Error Definition.....248

F.1.2 Test Method.....248

F.1.3 Test Criteria.....248

F.1.4 Calculation assumptions.....248

F.1.4.1 Statistical independence.....248

F.1.4.2 Applied formulas.....248

F.1.4.3 Approximation of the distribution.....249

F.1.5 Definition of good pass fail decision249

F.1.6 Good balance between test time and statistical significance.....250

F.1.7 Pass fail decision rules.....251

F.1.8 Test conditions for BER,BLER Tests.....252

F.1.9 Practical Use (informative).....253

Annex G (informative): Change History.....256

Foreword

This Technical Specification has been produced by the 3GPP.

The contents of the present document are subject to continuing work within the TSG and may change following formal TSG approval. Should the TSG modify the contents of this TS, it will be re-released by the TSG with an identifying change of release date and an increase in version number as follows:

Version x.y.z

where:

- x the first digit:
 - 1 presented to TSG for information;
 - 2 presented to TSG for approval;
 - 3 Indicates TSG approved document under change control.
- y the second digit is incremented for all changes of substance, i.e. technical enhancements, corrections, updates, etc.
- z the third digit is incremented when editorial only changes have been incorporated in the specification.

1 Scope

The present document specifies the Radio Frequency (RF) test methods and conformance requirements for UTRA Base Stations (BS) operating in the TDD mode. These have been derived from, and are consistent with, the UTRA base station (BS) specifications defined in 3GPP TS 25.105 [1]. The document covers all three options of the TDD mode, which are the 3,84 Mcps (incorporating MBSFN IMB), the 1,28 Mcps and the 7.68 Mcps options respectively. The requirements are listed in different subsections only if the parameters deviate.

In this TS, the reference point for RF connections (except for the measurement of mean transmitted RF carrier power) is the antenna connector, as defined by the manufacturer. This TS does not apply to repeaters or RF devices which may be connected to an antenna connector of a BS.

2 References

The following documents contain provisions which, through reference in this text, constitute provisions of the present document.

- References are either specific (identified by date of publication, edition number, version number, etc.) or non-specific.
- For a specific reference, subsequent revisions do not apply.
- For a non-specific reference, the latest version applies. In the case of a reference to a 3GPP document (including a GSM document), a non-specific reference implicitly refers to the latest version of that document in the same Release as the present document.

- [1] 3GPP TS 25.105: "UTRA (BS) TDD: Radio transmission and reception".
- [2] IEC 60721-3-3 (1994): "Classification of environmental conditions - Part 3: Classification of groups of environmental parameters and their severities - Section 3: Stationary use at weather protected locations".
- [3] IEC 60721-3-4 (1995): "Classification of environmental conditions - Part 3: Classification of groups of environmental parameters and their severities - Section 4: Stationary use at non-weather protected locations".
- [4] IEC 60068-2-1 (1990): "Environmental testing - Part 2: Tests. Tests A: Cold".
- [5] ETR 028: "Uncertainties in the measurement of mobile radio equipment characteristics".
- [6] Recommendation ITU-R SM.329: "Unwanted emissions in the spurious domain".
- [7] Recommendation ITU-R SM.328: "Spectra and bandwidth of emissions".
- [8] IEC 60068-2-6 (1995): "Environmental testing - Part 2: Tests - Test Fc: Vibration (sinusoidal)".
- [9] 3GPP TR 25.942: "RF System Scenarios".
- [10] ITU-T recommendation O.153: "Basic parameters for the measurement of error performance at bit rates below the primary rate".
- [11] 3GPP TS 36.104: "Evolved Universal Terrestrial Radio Access (E-UTRA); Base Station (BS) radio transmission and reception".
- [12] 3GPP TS 37.141: "E-UTRA, UTRA and GSM/EDGE; Multi-Standard Radio (MSR) Base Station (BS) conformance testing".

3 Definitions, symbols, and abbreviations

3.1 Definitions

Ancillary RF amplifier: a piece of equipment, which when connected by RF coaxial cables to the BS, has the primary function to provide amplification between the transmit and/or receive antenna connector of a BS and an antenna without requiring any control signal to fulfil its amplifying function.

Bit Error Ratio: The Bit Error Ratio is defined as the ratio of the bits wrongly received to all data bits sent. The bits are the data bits above the convolutional/turbo decoder. The BER is the overall BER independent of frame erasures or when erased frames are not defined.

Block Error Ratio: A Block Error Ratio is defined as the ratio of the number of erroneous blocks received to the total number of blocks sent. An erroneous block is a Transport Block whose cyclic redundancy check (CRC) is wrong.

Power Spectral Density: The units of Power Spectral Density (PSD) are extensively used in this document. PSD is a function of power versus frequency and when integrated across a given bandwidth, the function represents the mean power in such a bandwidth. When the mean power is normalised to (divided by) the chip-rate it represents the mean energy per chip. Some signals are directly defined in terms of energy per chip, (DPCH_Ec, Ec, and P-CCPCH_Ec) and others defined in terms of PSD (Io, Ioc, Ior and \hat{I}_{or}). There also exist quantities that are a ratio of energy per chip to PSD (DPCH_Ec/Ior, Ec/Ior etc.). This is the common practice of relating energy magnitudes in communication systems.

It can be seen that if both energy magnitudes in the ratio are divided by time, the ratio is converted from an energy ratio to a power ratio, which is more useful from a measurement point of view. It follows that an energy per chip of X dBm/3,84 MHz can be expressed as a mean power per chip of X dBm. Similarly, a signal PSD of Y dBm/3,84 MHz can be expressed as a signal power of Y dBm.

Mean power: When applied to a CDMA modulated signal this is the power (transmitted or received) in a bandwidth of at least $(1 + \alpha)$ times the chip rate of the radio access mode. The period of measurement shall be a transmit timeslot excluding the guard period unless otherwise stated.

NOTE: The roll-off factor α is defined in section 6.8.1.

RRC filtered mean power: The mean power as measured through a root raised cosine filter with roll-off factor α and a bandwidth equal to the chip rate of the radio access mode.

NOTE: The RRC filtered mean power of a perfectly modulated CDMA signal is 0.246 dB lower than the mean power of the same signal.

Code domain power: That part of the mean power which correlates with a particular (OVSF) code channel. The sum of all powers in the code domain equals the mean power in a bandwidth of $(1 + \alpha)$ times the chip rate of the radio access mode.

Output power: The mean power of one carrier of the base station, delivered to a load with resistance equal to the nominal load impedance of the transmitter.

Maximum output power: The mean power level per carrier of the base station measured at the antenna connector in a specified reference condition. The period of measurement shall be a transmit timeslot excluding the guard period.

MBSFN-only operation: Operation of a dedicated carrier solely for the purposes of MBSFN transmission. No receive functionality is implemented on the specified carrier frequency.

Rated output power: Rated output power of the base station is the mean power level per carrier that the manufacturer has declared to be available at the antenna connector.

Total power dynamic range: The difference between the maximum and the minimum output power of the base station for a specified reference condition.

3.2 Symbols

For the purposes of the present document, the following symbols apply:

α Roll-off factor

3.3 Abbreviations

For the purposes of the present document, the following and abbreviations apply:

3GPP	3rd Generation Partnership Project
16QAM	16 - Quadrature Amplitude Modulation
AWGN	Additive White Gaussian Noise
BER	Bit Error Ratio
BLER	Block Error Ratio
dB	decibel
dBm	decibel relative to 1 milliWatt
DPCHo	Mechanism used to simulate an individual intracell interferer in the cell with one code and a spreading factor of 16
$\frac{DPCH_o - E_c}{I_{or}}$	Ratio of the average transmit energy per PN chip for the DPCH _o to the total transmit power spectral density of all users in the cell in one timeslot as measured at the BS antenna connector
EVM	Error Vector Magnitude
F	Frequency (of the assigned channel frequency of the wanted signal)
F _w	Frequency offset of the unwanted interfering signal from the assigned channel frequency of the wanted signal
HSDPA	High Speed Downlink Packet Access
HSUPA	High Speed Uplink Packet Access
HS-DSCH	High Speed Downlink Shared Channel
HS-PDSCH	High Speed Physical Downlink Shared Channel
IMB	Integrated Mobile Broadcast
IMT-2000	International Mobile Telecommunications 2000
loc	Power spectral density (integrated in a noise bandwidth equal to the chip rate and normalized to the chip rate) of a band limited white noise source (simulating interference from other cells) as measured at the BS antenna connector.
\hat{f}_{or}	Received power spectral density (integrated in a bandwidth (1+a) times the chip rate and normalized to the chip rate) of all users in the cell in one timeslot as measured at the BS antenna connector
IPR	Intellectual Property Rights
MBMS	Multimedia Broadcast Multicast Service
MBSFN	MBMS over a Single Frequency Network
MC-HSDPA	Multi-carrier HSDPA
MC-HSUPA	Multi-carrier HSUPA
P	Output power
P _{out}	Output power of the base station
P _{max}	Maximum output power of the base station
QPSK	Quadrature Phase Shift Keying
RAT	Radio Access Technology
RBER	Residual BER
RCDE	Relative Code Domain Error
REFSENS	Reference Sensitivity Level
RMS	Root-Mean Square
PRAT	Rated output power of the base station
RRC	Root-Raised Cosine
T _c	Chip duration
TDM	Time Division Multiplexing
TS	Time Slot

4 Frequency bands and channel arrangement

4.1 General

The information presented in this section is based on a chip rate of 3,84 Mcps, 1,28 Mcps respectively and 7.68 Mcps .

NOTE: Other chip rates may be considered in future releases.

4.2 Frequency bands

UTRA/TDD is designed to operate in the following bands:

- a) 1900 - 1920 MHz: Uplink and downlink transmission
2010 - 2025 MHz Uplink and downlink transmission
- b) 1850 - 1910 MHz: Uplink and downlink transmission
1930 - 1990 MHz: Uplink and downlink transmission
- c) 1910 - 1930 MHz: Uplink and downlink transmission
- d) 2570 - 2620 MHz Uplink and downlink transmission
- e) 2300 - 2400 MHz Uplink and downlink transmission
- f) 1880 - 1920 MHz: Uplink and downlink transmission

Note 1: Deployment in existing and other frequency bands is not precluded.

Note 2: In China, Band a only includes 2010 - 2025 MHz for 1.28 Mcps TDD option.

4.3 TX-RX frequency separation

4.3.1 3,84 Mcps TDD option

No TX-RX frequency separation is required as Time Division Duplex (TDD) is employed. Each TDMA frame consists of 15 timeslots where each timeslot can be allocated to either transmit or receive.

4.3.2 1,28 Mcps TDD option

No TX-RX frequency separation is required as Time Division Duplex (TDD) is employed. Each subframe consists of 7 main timeslots where all main timeslots (at least the first one) before the single switching point are allocated UL and all main timeslots (at least the last one) after the single switching point are allocated DL.

4.3.3 7,68 Mcps TDD option

No TX-RX frequency separation is required as Time Division Duplex (TDD) is employed. Each TDMA frame consists of 15 timeslots where each timeslot can be allocated to either transmit or receive.

4.4 Channel arrangement

4.4.1 Channel spacing

4.4.1.1 3,84 Mcps TDD option

The nominal channel spacing is 5 MHz, but this can be adjusted to optimise performance in a particular deployment scenario.

4.4.1.2 1,28 Mcps TDD option

The nominal channel spacing is 1,6 MHz, but this can be adjusted to optimise performance in a particular deployment scenario.

4.4.1.3 7,68 Mcps TDD option

The nominal channel spacing is 10 MHz, but this can be adjusted to optimise performance in a particular deployment scenario.

4.4.2 Channel raster

The channel raster is 200 kHz for all bands, which means that the carrier frequency must be a multiple of 200 kHz.

4.4.2.1 3,84 Mcps TDD Option

In addition a number of additional centre frequencies are specified according to table 5.1, which means that the centre frequencies for these channels are shifted 100 kHz relative to the general raster.

4.4.3 Channel number

The carrier frequency is designated by the UTRA absolute radio frequency channel number (UARFCN). The value of the UARFCN in the IMT2000 band is defined in the general case as follows:

$$N_t = 5 * F \text{ MHz} \qquad 0,0 \leq F \leq 3276,6 \text{ MHz}$$

where F is the carrier frequency in MHz.

Additional channels applicable to operation in the frequency band defined in sub-clause 5.2(d) for 3,84 Mcps are defined via the following UARFCN definition:

$$N_t = 5 * (F - 2150.1 \text{ MHz}) \qquad 2572.5 \text{ MHz} \leq F \leq 2617.5 \text{ MHz}$$

The 10 additional UARFCN for operations in frequency band defined in sub-clause 5.2(d) for 3,84 Mcps are hence: 2112, 2137, 2162, 2187, 2212, 2237, 2262, 2287, 2312, 2337.

5 General test conditions and declarations

The requirements of this clause apply to all applicable tests in this TS.

Many of the tests in this TS measure a parameter relative to a value that is not fully specified in the UTRA specifications. For these tests, the Minimum Requirement is determined relative to a nominal value specified by the manufacturer.

Certain functions of a BS are optional in the UTRA specifications. Some requirements for the BS may be regional as listed in subclause 5.17.

When specified in a test, the manufacturer shall declare the nominal value of a parameter, or whether an option is supported.

5.1 Base station classes

5.1.1 Applicability of requirements and BS class definition

The requirements in this specification apply to Wide Area base stations, Local Area base stations and Home Base Stations in co-ordinated network operation, unless otherwise stated.

Wide Area BS are characterised by requirements derived from Macro Cell and Micro Cell scenarios with BS to UE coupling losses equal to 70 dB and 53 dB. The Wide Area Base Station has the same requirements as the base station for General Purpose application in Release 99 for 3,84 Mcps option, and in release 4 for both 3,84 Mcps and 1,28 Mcps option.

Local Area BS are characterised by requirements derived from Pico Cell scenarios with a BS to UE coupling loss equals to 45 dB.

Home Base Stations are characterised by requirements derived from Femto Cell scenarios.

5.1.2 Manufacturer's declaration

The manufacturer shall declare the intended class of the BS under test.

5.2 Output power

The manufacturer shall declare the rated output power, PRAT, of the base station. PRAT is defined in subclause 3.1.

5.3 Specified frequency range

The manufacturer shall declare:

- which of the frequency bands defined in sub-clause 4.2 is supported by the BS.
- the frequency range within the above frequency band(s) supported by the BS. As TDD is employed, the same frequency range is used for transmit and receive operation. For the case of MBSFN-only operation, the frequency range is used for transmit only, since no receive requirement exists.

Many tests in this TS are performed with appropriate frequencies in the bottom, middle and top of the operating frequency band of the BS. These are denoted as RF channels B (bottom), M (middle) and T (top).

Unless otherwise stated, the test shall be performed with a single carrier at each of the RF channels B, M and T.

When the requirements are specific to multiple carriers, and the BS is declared to support $N > 1$ carriers, numbered from 1 to N, the interpretation of B, M and T for test purposes shall be as follows:

For testing at B,

- the carrier of lowest frequency shall be centered on B.

For testing at M,

- if the number N of carriers supported is odd, the carrier $(N+1)/2$ shall be centered on M,
- if the number N of carriers supported is even, the carrier $N/2$ shall be centered on M.

For testing at T,

- the carrier of highest frequency shall be centered on T.

When a test is performed by a test laboratory, the UARFCNs to be used for RF channels B, M and T shall be specified by the laboratory. The laboratory may consult with operators, the manufacturer or other bodies.

When a test is performed by a manufacturer, the UARFCNs to be used for RF channels B, M and T may be specified by an operator.

5.4 Relationship between RF generation and chip clock

The manufacturer shall declare compliance with the requirement that the BS shall use the same frequency source for both RF generation and the chip clock.

5.5 Spectrum emission mask

The manufacturer shall declare whether the BS under test is intended to operate in regions where conformance to the spectrum emission mask defined in subclause 6.6.2.1.2 is mandatory. If so, the conformance test for spectrum emission mask specified in subclause 6.6.2.1 shall be performed; otherwise, this test is not required.

5.6 Adjacent Channel Leakage power Ratio (ACLR)

The manufacturer shall declare:

- whether the BS under test is intended to operate in proximity to either another TDD BS or FDD BS that comprises uplink receive functionality operating on the first or second adjacent frequency. If so, conformance with the ACLR requirement specified in subclause 6.6.2.2.2 is mandatory; otherwise, this requirement need not to be tested.
- whether the BS under test is intended to operate co-sited to either another TDD BS or FDD BS that comprises uplink receive functionality operating on the first or second adjacent frequency. If so, conformance with the ACLR requirement specified in subclause 6.6.2.2.3 is mandatory; otherwise, this requirement need not to be tested.

5.7 Tx spurious emissions

5.7.1 Category of spurious emissions limit

The manufacturer shall declare one of the following:

- a) the BS shall be tested against Category A limits for spurious emissions, as defined in ITU-R Recommendation SM.329-9 [6].

or

- b) the BS shall be tested against Category B limits for spurious emissions, as defined in ITU-R Recommendation SM.329-9 [6].

If the manufacturer declares Category A limits to be applicable, conformance with the spurious emissions requirements specified in subclause 6.6.3.2.1.1 is mandatory, and the requirements specified in subclause 6.6.3.2.1.2 need not to be tested.

If the manufacturer declares Category B limits to be applicable, conformance with the spurious emissions requirements specified in subclause 6.6.3.2.1.2 is mandatory, and the requirements specified in subclause 6.6.3.2.1.1 need not to be tested.

5.7.2 Co-existence with GSM

The manufacturer shall declare:

- whether the BS under test is intended to operate in geographic areas in which also GSM 900 is deployed. If so, compliance with the conformance requirement specified in subclause 6.6.3.2.2.1 is mandatory; otherwise, this requirement needs not to be tested.
- whether the BS under test is intended to operate co-located with a GSM 900 BTS. If so, compliance with the conformance requirement specified in subclause 6.6.3.2.2.2 is mandatory; otherwise, this requirement needs not to be tested.

5.7.3 Co-existence with DCS 1800

The manufacturer shall declare:

- whether the BS under test is intended to operate in geographic areas in which also DCS 1800 is deployed. If so, compliance with the conformance requirement specified in subclause 6.6.3.2.3.1 is mandatory; otherwise, this requirement needs not to be tested.
- whether the BS under test is intended to operate co-located with a DCS 1800 BTS. If so, compliance with the conformance requirement specified in subclause 6.6.3.2.3.2 is mandatory; otherwise, this requirement needs not to be tested.

5.7.4 Co-existence with UTRA FDD

The manufacturer shall declare:

- whether the BS under test is intended to operate in geographic areas in which also UTRA FDD is deployed. If so, compliance with the conformance requirement specified in subclause 6.6.3.2.4.1 is mandatory; otherwise, this requirement needs not to be tested.
- whether the BS under test is intended to operate co-located with a UTRA FDD BS. If so, compliance with the conformance requirement specified in subclause 6.6.3.2.4.2 is mandatory; otherwise, this requirement needs not to be tested.

5.7.5 Co-existence with unsynchronised UTRA TDD and/or E-UTRA TDD

The manufacturer shall declare:

- whether the BS under test is intended to operate in geographic areas in which also unsynchronised UTRA TDD and/or E-UTRA TDD that comprises uplink receive functionality is deployed. If so, compliance with the conformance requirement specified in subclause 6.6.3.2.5.1 is mandatory; otherwise, this requirement need not to be tested.
- whether the BS under test is intended to operate co-located with a unsynchronised UTRA TDD and/or E-UTRA TDD BS that comprises uplink receive functionality. If so, compliance with the conformance requirement specified in subclause 6.6.3.2.5.2 is mandatory; otherwise, this requirement needs not to be tested.

5.8 Blocking characteristics

The conformance requirements with respect to the parameter blocking characteristics are dependent on the operating frequency bands of the BS under test; see subclause 7.5.2. However, the need for a manufacturer's declaration of the frequency bands supported by the BS is already covered by subclause 5.3. The relationship between the frequency bands supported by the BS and the mandatory blocking requirements is given in table 5.1.

Table 5.1: Relationship between the frequency bands supported by the BS and the mandatory blocking requirements

Supported frequency band according to manufacturer's declaration	Mandatory blocking requirement
subclause 4.2a)	table 7.6
subclause 4.2b)	table 7.7
subclause 4.2c)	table 7.8

In addition, the manufacturer shall declare:

- whether the BS under test is intended to operate co-located with a GSM 900 BTS or a DCS 1800 BTS. If so, compliance with the conformance requirement specified in table 7.9 or 7.10, respectively, is mandatory; otherwise, this requirement needs not to be tested.

5.9 Test environments

For each test in this TS, the environmental conditions under which the BS is to be tested are defined.

5.9.1 Normal test environment

When a normal test environment is specified for a test, the test should be performed under any combination of conditions between the minimum and maximum limits stated in table 5.2.

Table 5.2: Limits of conditions for Normal Test Environment

Condition	Minimum	Maximum
Barometric pressure	86 kPa	106 kPa
Temperature	15°C	30°C
Relative Humidity	20 %	85 %
Power supply	Nominal, as declared by the manufacturer	
Vibration	Negligible	

The ranges of barometric pressure, temperature and humidity represent the maximum variation expected in the uncontrolled environment of a test laboratory. If it is not possible to maintain these parameters within the specified limits, the actual values shall be recorded in the test report.

NOTE: This may, for instance, be the case for measurements of radiated emissions performed on an open field test site.

5.9.2 Extreme test environment

The manufacturer shall declare one of the following:

- The equipment class for the equipment under test, as defined in IEC 60721-3-3 [2].
- The equipment class for the equipment under test, as defined in IEC 60721-3-4 [3].
- For equipment that does not comply to the mentioned classes, the relevant classes from IEC 60 721 documentation for Temperature, Humidity and Vibration shall be declared.

NOTE: Reduced functionality for conditions that fall out side of the standard operational conditions are not tested in this TS. These may be stated and tested separately.

5.9.2.1 Extreme temperature

When an extreme temperature test environment is specified for a test, the test shall be performed at the standard minimum and maximum operating temperatures defined by the manufacturer's declaration for the equipment under test.

Minimum temperature:

- The test shall be performed with the environmental test equipment and methods of inducing the required environmental phenomena into the equipment, conforming to the test procedure of IEC 60 068-2-1 [4], Environmental Testing, Part 2: Tests - Tests A: Cold. The equipment shall be maintained at the stabilized condition for the duration of the test sequence.

Maximum temperature:

- The test shall be performed with the environmental test equipment and methods of inducing the required environmental phenomena in to the equipment, conforming to the test procedure of IEC 60 068-2-2 [5] (Environmental Testing, Part 2: Tests - Tests Bd Dry heat). The equipment shall be maintained at the stabilized condition for the duration of the test sequence.

NOTE: It is recommended that the equipment is made fully operational prior to the equipment being taken to its lower operating temperature.

5.9.3 Vibration

When vibration conditions are specified for a test, the test shall be performed while the equipment is subjected to a vibration sequence as defined by the manufacturers declaration for the equipment under test. This shall use the environmental test equipment and methods of inducing the required environmental phenomena in to the equipment, conforming to the test procedure of IEC 60 068-2-6 [8], Environmental Testing, Part 2: Tests - Test Fc and guidance: Vibration (Sinusoidal). Other environmental conditions shall be within the ranges specified in subclause 5.9.1, Normal test environment.

NOTE: The higher levels of vibration may induce undue physical stress in to equipment after a prolonged series of tests. The testing body should only vibrate the equipment during the RF measurement process.

5.9.4 Power supply

When extreme power supply conditions are specified for a test, the test shall be performed at the standard upper and lower limits of operating voltage defined by the manufacturer's declaration for the equipment under test.

Upper voltage limit

- The equipment shall be supplied with a voltage equal to the upper limit declared by the manufacturer (as measured at the input terminals to the equipment). The tests shall be carried out at a steady state minimum and maximum limit declared by the manufacturer for the equipment, to the methods described in IEC 60 068-2-1 [4] Test Ab/Ad: Cold and IEC 60 068-2-2 [5] Test Bb/Bd: Dry Heat.

Lower voltage limit

- The equipment shall be supplied with a voltage equal to the lower limit declared by the manufacturer (as measured at the input terminals to the equipment). The tests shall be carried out at a steady state minimum and maximum limit declared by the manufacturer for the equipment, to the methods described in IEC 60 068-2-1 [4] Test Ab/Ad: Cold and IEC 60 068-2-2 [5] Test Bb/Bd: Dry Heat.

5.10 Acceptable uncertainty of Test System

The maximum acceptable uncertainty of the Test System is specified below for each test, where appropriate. The Test System shall enable the stimulus signals in the test case to be adjusted to within the specified tolerance and the equipment under test to be measured with an uncertainty not exceeding the specified values. All tolerances and uncertainties are absolute values and are valid for a confidence level of 95 %, unless otherwise stated.

A confidence level of 95 % is the measurement uncertainty tolerance interval for a specific measurement that contains 95 % of the performance of a population of test equipment.

For RF tests it should be noted that the uncertainties in subclause 5.10 apply to the Test System operating into a nominal 50 ohm load and do not include system effects due to mismatch between the DUT and the Test System.

5.10.1 Measurement of test environments

The measurement accuracy of the BS test environments defined in subclause 5.9 shall be:

Pressure:	± 5 kPa
Temperature:	± 2 degrees
Relative Humidity:	± 5 %
DC Voltage:	± 1,0 %
AC Voltage:	± 1,5 %
Vibration:	10 %
Vibration frequency:	0,1 Hz

The above values shall apply unless the test environment is otherwise controlled and the specification for the control of the test environment specifies the uncertainty for the parameter.

5.10.2 Measurement of transmitter

Table 5.3: Maximum Test System Uncertainty for transmitter tests

Subclause	Maximum Test System Uncertainty	Derivation of Test System Uncertainty
6.2 Maximum output power	$\pm 0,7$ dB	
6.3 Frequency stability	± 12 Hz	
6.4.2 Power control steps	single step: $\pm 0,1$ dB ten steps: $\pm 0,3$ dB	Result is difference between two absolute Code Domain Power measurements on the power controlled DPCH.
6.4.3 Power control dynamic range	$\pm 0,3$ dB	
6.4.4 Minimum output power	$\pm 0,7$ dB	
6.4.5 Primary CCPCH power	$\pm 0,8$ dB	
6.4.6 Differential accuracy of Primary CCPCH power	$\pm 0,1$ dB	
6.5.1 Transmit OFF power	$\pm 2,0$ dB	
6.5.2 Transmit ON/OFF time mask	3,84 Mcps TDD option: Tx power limit = -79 dBm: $\pm 2,0$ dB Tx power limit = -33 dBm: $\pm 0,7$ dB 1,28 Mcps TDD option: Tx power limit = -82 dBm: $\pm 2,0$ dB Tx power limit = -42 dBm: $\pm 0,7$ dB	
6.6.1 Occupied Bandwidth	± 100 kHz	Accuracy = $\pm 3 \cdot \text{RBW}$. Assume 30 kHz bandwidth
6.6.2.1 Spectrum emission mask	$\pm 1,5$ dB	

<p>6.6.2.2 Adjacent Channel Leakage power Ratio (ACLR)</p>	<p><u>3,84 Mcps TDD option:</u></p> <p>minimum requirement: 5 MHz offset: $\pm 0,8$ dB 10 MHz offset: $\pm 0,8$ dB</p> <p>requirement for operation in the same geographic area with unsynchronised TDD BS on adjacent channels: Wide Area BS: 5 MHz offset: ± 4 dB 10 MHz offset: ± 4 dB Local Area BS: 5 MHz offset: $\pm 0,8$ dB 10 MHz offset: $\pm 0,8$ dB</p> <p>requirement for operation in the same geographic area with FDD BS on adjacent channels: Wide Area BS: 5 MHz offset: TBD 10 MHz offset: ± 4 dB Local Area BS: 5 MHz offset: $\pm 0,8$ dB 10 MHz offset: $\pm 0,8$ dB</p> <p>requirement in case of co-siting with unsynchronised TDD BS or FDD BS operating on adjacent channels: Wide Area BS: 5 MHz offset: TBD 10 MHz offset: TBD Local Area BS (co-siting with TDD BS): 5 MHz offset: ± 1 dB 10 MHz offset: ± 1 dB</p> <p><u>1,28 Mcps TDD option:</u></p> <p>minimum requirement: 1,6 MHz offset: $\pm 0,8$ dB 3,2 MHz offset: $\pm 0,8$ dB</p> <p>requirement for operation in the same geographic area with unsynchronised 1,28 Mcps TDD BS on adjacent channels: Wide Area BS: 1,6 MHz offset: ± 1 dB 3,2 MHz offset: ± 1 dB Local Area BS: 1,6 MHz offset: $\pm 0,8$ dB 3,2 MHz offset: $\pm 0,8$ dB</p> <p>requirement for operation in the same geographic area with unsynchronised TDD BS on adjacent channels: Wide Area BS: 3,4 MHz offset: ± 1 dB Local Area BS: 3,4 MHz offset: $\pm 0,8$ dB</p> <p>requirement for operation in the same geographic area with FDD BS on adjacent channels: Wide Area BS: ± 4 dB Local Area BS: $\pm 0,8$ dB</p>	
--	---	--

	<p>requirement in case of co-siting with unsynchronised 1,28 Mcps TDD BS on an adjacent channel: Wide Area BS: 1,6 MHz offset: TBD 3,2 MHz offset: TBD Local Area BS: Wide Area BS: ± 1 dB Local Area BS: ± 1 dB</p> <p>requirement in case of co-siting with unsynchronised TDD BS on an adjacent channel: Wide Area BS: 3,4 MHz offset: TBD Local Area BS: 3,4 MHz offset: ± 1 dB</p> <p>requirement in case of co-siting with FDD BS on an adjacent channel: Wide Area BS: TBD</p> <p>Note: Impact of measurement period (averaging) and intermod effects in the measurement receiver not yet fully studied.</p>	
--	--	--

6.6.3 Spurious emissions	$\pm 2,0$ dB for BS and coexistence bands for results > -60 dBm $\pm 3,0$ dB for results < -60 dBm Outside above range: $f \leq 2,2$ GHz: $\pm 1,5$ dB $2,2$ GHz $< f \leq 4$ GHz: $\pm 2,0$ dB $f > 4$ GHz: $\pm 4,0$ dB	
6.7 Transmit intermodulation	The value below applies to the setting of the interference signal level only and is unrelated to the measurement uncertainty of the tests (6.6.2.1, 6.6.2.2 and 6.6.3) which have to be carried out in the presence of the interference signal. ± 1 dB	The uncertainty of the interferer has double the effect on the result due to the frequency offset.
6.8.1 Modulation accuracy	$\pm 2,5$ % (for single code)	
6.8.2 Peak code domain error	± 1 dB	
6.8.3 Relative Code Domain Error	$\pm 1,0$ dB	
6.8.4 Time alignment error in MIMO transmission	1,28 Mcps TDD option: $\pm [78]$ ns	

5.10.3 Measurement of receiver

Table 5.4: Maximum Test System Uncertainty for receiver tests

Subclause	Maximum Test System Uncertainty (see NOTE 1)	Derivation of Test System Uncertainty
7.2 Reference sensitivity level	$\pm 0,7$ dB	
7.3 Dynamic range	$\pm 1,2$ dB	Formula = SQRT(signal level error ² and AWGN level error ²)
7.4 Adjacent Channel Selectivity (ACS)	$\pm 1,1$ dB	Formula = SQRT (wanted_level_error ² + interferer_level_error ²) + ACLR effect The ACLR effect is calculated by: (Formula to follow)
7.5 Blocking characteristics	Maximum Test System Accuracy with Frequency offset of interfering signal < 15MHz: $\pm 1,4$ dB Frequency offset of interfering signal ≥ 15 MHz: f < 2,2 GHz: $\pm 1,1$ dB 2,2 GHz < f ≤ 4 GHz: $\pm 1,8$ dB f > 4 GHz: $\pm 3,2$ dB	Formula = SQRT (wanted_level_error ² + interferer_level_error ²) + ACLR effect + Broadband noise (Frequency offset < 15 MHz: assuming ACLR of interfering signal = 68 dB, measurement uncertainty of wanted signal = 0,7 dB) (Frequency offset ≥ 15 MHz: assuming -130 dBc broadband noise from interfering signal) Harmonics and spurs of the interfering signal need to be carefully considered. Perhaps need to avoid harmonics of the interferer that fall on top of the receive channel. For the -15 dBm CW interfering signal, filtering of the interfering signal (at least 25 dB) is necessary to eliminate problems with broadband noise falling into the bandwidth of the wanted signal.
7.6 Intermodulation characteristics	$\pm 1,3$ dB	Formula = SQRT ((2*CW_level_error) ² + (mod_level_error) ² + (wanted_signal_level_error) ²) (assuming: CW_level_error: 0,5 dB mod_level_error: 0,5 dB wanted_signal_level_error: 0,7 dB)

7.7 Spurious emissions	$\pm 3,0$ dB for BS receive band (-78 dBm) Outside above range: $f \leq 2,2$ GHz: $\pm 2,0$ dB (-57 dBm) $2,2$ GHz < $f \leq 4$ GHz: $\pm 2,0$ dB (-47 dBm) $f > 4$ GHz: $\pm 4,0$ dB (-47 dBm) (see note 2)	
NOTE 1: Unless otherwise noted, only the Test System stimulus error is considered here. The effect of errors in the BER/FER measurements due to finite test duration is not considered.		
NOTE 2: The Test System uncertainty figures for Spurious emissions apply to the measurement of the DUT and not to any stimulus signals.		

5.10.4 Measurement of performance requirements

Table 5.5: Maximum Test System Uncertainty for Performance Requirements

Subclause	Maximum Test System Uncertainty (see NOTE 1)
8.2 Demodulation in static propagation conditions	TBD
8.3 Demodulation of DCH in multipath fading conditions	TBD
8.3A Demodulation of DCH in high speed train conditions	± 0.4 dB
NOTE 1: Only the overall stimulus error is considered here. The effect of errors in the BER/FER measurements due to finite test duration is not considered.	

5.11 Test Tolerances (informative)

The Test Tolerances defined in this subclause have been used to relax the Minimum Requirements in this specification to derive the Test Requirements.

The Test Tolerances are derived from Test System uncertainties, regulatory requirements and criticality to system performance. As a result, the Test Tolerance may sometimes be set to zero.

The test tolerances should not be modified for any reason, e. g. to take account of commonly known test system errors (such as mismatch, cable loss, etc.)

5.11.1 Transmitter

Table 5.6: Test Tolerance for transmitter tests

Subclause	Test Tolerance (see NOTE)
6.2 Maximum output power	0,7 dB
6.3 Frequency stability	12 Hz
6.4.2 Power control steps	single step: 0,1 dB ten steps: 0,3 dB
6.4.3 Power control dynamic range	0,3 dB
6.4.4 Minimum output power	0,7 dB
6.4.5 Primary CCPCH power	0,8 dB
6.4.6 Differential accuracy of Primary CCPCH power	$\pm 0,1$ dB
6.5.1 Transmit OFF power	2,0 dB
6.5.2 Transmit ON/OFF time mask	3,84 Mcps TDD option: Tx power limit = -79 dBm: 2,0 dB Tx power limit = -33 dBm: 0,7 dB 1,28 Mcps TDD option: Tx power limit = -82 dBm: 2,0 dB Tx power limit = -42 dBm: 0,7 dB 7,68 Mcps TDD option: Tx power limit = -76 dBm: 2,0 dB Tx power limit = -33 dBm: 0,7 dB
6.6.1 Occupied Bandwidth	0 kHz
6.6.2.1 Spectrum emission mask	1,5 dB

6.6.2.2 Adjacent Channel Leakage power Ratio (ACLR)	<p><u>3.84 Mcps TDD option:</u> minimum requirement: 0,8 dB</p> <p>operation in the same geographic area: Wide Area BS: 4 dB for TDD BS on adjacent channels TBD/4 dB for FDD BS on adjacent channels Local Area BS: 0,8 dB</p> <p>co-siting: Wide Area BS: TBD Local Area BS: 1 dB</p> <p><u>1,28 Mcps TDD option:</u> minimum requirement: 0,8 dB</p> <p>operation in the same geographic area: Wide Area BS: 1 dB for TDD BS on adjacent channels 4 dB for FDD BS on adjacent channels Local Area BS: 0,8 dB</p> <p>co-siting: Wide Area BS: TBD Local Area BS: 1 dB for TDD BS on adjacent channels</p> <p><u>7,68 Mcps TDD option:</u> minimum requirement: 0,8 dB</p> <p>operation in the same geographic area: Wide Area BS: 4 dB for TDD BS on adjacent channels TBD/4 dB for FDD BS on adjacent channels Local Area BS: 0,8 dB</p> <p>co-siting: Wide Area BS: TBD Local Area BS: 1 dB</p>
6.6.3 Spurious emissions	0 dB
6.7 Transmit intermodulation	<p>Testing of transmit intermodulation consists of 3 parts:</p> <ul style="list-style-type: none"> - testing of spectrum emission mask, see 6.6.2.1 - testing of ACLR, see 6.6.2.2 - testing of spurious emissions, see 6.6.3 <p>For each of these parts, the respective Test Tolerances as specified in this table shall apply.</p> <p>Test Tolerance for setting of the interferer power level: 0 dB</p>
6.8.1 Modulation accuracy	0 %
6.8.2 Peak code domain error	1 dB
6.8.3 Relative Code Domain Error	1.0 dB
6.8.4 Time alignment error in MIMO transmission	1,28 Mcps TDD option: [78] ns
NOTE: Unless otherwise stated, the Test Tolerances are applied to the DUT Minimum Requirement. See Annex D.	

5.11.2 Receiver

Table 5.7: Test Tolerances for receiver tests

Subclause	Test Tolerances (see NOTE 1)
7.2 Reference sensitivity level	0,7 dB
7.3 Dynamic range	1,2 dB
7.4 Adjacent Channel Selectivity (ACS)	0 dB
7.5 Blocking characteristics	0 dB
7.6 Intermodulation characteristics	0 dB
7.7 Spurious emissions	0 dB (see NOTE 2)
NOTE 1: Unless otherwise stated, the Test Tolerances are applied to the stimulus signal(s). See Annex D.	
NOTE 2: The Test Tolerance is applied to the DUT Minimum Requirement. See Annex D.	

5.11.3 Performance requirements

Table 5.8: Test Tolerances for performance requirements

Subclause	Test Tolerance (see NOTE)
8.2 Demodulation in static propagation conditions	TBD
8.3 Demodulation of DCH in multipath fading conditions	TBD
8.3A Demodulation of DCH in high speed train conditions	0.4dB
NOTE: Unless otherwise stated, the Test Tolerances are applied to the stimulus signal(s). See Annex D.	

5.12 Interpretation of measurement results

The measurement results returned by the Test System are compared - without any modification - against the Test Requirements as defined by the shared risk principle.

The Shared Risk principle is defined in ETR 273 Part 1 sub-part 2 section 6.5.

The actual measurement uncertainty of the Test System for the measurement of each parameter shall be included in the test report.

The recorded value for the Test System uncertainty shall be, for each measurement, equal to or lower than the appropriate figure in subclause 5.10 of this TS.

If the Test System for a test is known to have a measurement uncertainty greater than that specified in subclause 5.10, it is still permitted to use this equipment provided that an adjustment is made as follows:

Any additional uncertainty in the Test System over and above that specified in subclause 5.10 shall be used to tighten the Test Requirement - making the test harder to pass. (For some tests, e. g. receiver tests, this may require modification of stimulus signals).

This procedure (defined in Annex D) will ensure that a Test System not compliant with subclause 5.10 does not increase the chance of passing a device under test where that device would otherwise have failed the test if a Test System compliant with subclause 5.10 had been used.

5.13 Selection of configurations for testing

Measurements shall be performed within the time slots under test as specified individually for each test within the subclause "Initial conditions".

Most tests in this TS are only performed for a subset of the possible combinations of test conditions. For instance:

- Not all TRXs in the configuration may be specified to be tested.
- Only one RF channel may be specified to be tested.
- Only one timeslot may be specified to be tested.

When a test is performed by a test laboratory, the choice of which combinations are to be tested shall be specified by the laboratory. The laboratory may consult with operators, the manufacturer or other bodies.

When a test is performed by a manufacturer, the choice of which combinations are to be tested may be specified by an operator.

5.14 BS Configurations

This TS has been written to specify tests for the standard configurations of BS which have been assumed in UTRA requirements specifications, in particular TS 25.105 [1]. However, there are other configurations of BS which comply with these specifications, but for which the application of these specifications is not fully defined. For some such configurations there may be alternate ways to apply the requirements of this specification to testing of the configuration, or some variation in the test method may be necessary. It may therefore be necessary for the parties to the testing to reach agreement over the method of testing in advance.

If the BS is supplied in a number of different environmental enclosures or configurations, it may not be necessary to test RF parameters for each environmental configuration, provided that it can be demonstrated that the equipment has been tested at the worst internal environmental conditions.

Where alternative interpretations of this specification are possible for a BS configuration under test, the interpretation which has been adopted in performing the test shall be recorded with the test results.

Where variation in the test method within this TS has been necessary to enable a BS configuration to be tested, the variation in the test method which has been made in performing the test shall be recorded with the test results. Where possible, agreement should be reached in advance about the nature of such a variation with any party who will later receive the test results.

Possible interpretations of this TS for some common configurations are given in the following subclauses.

5.14.1 Receiver diversity

For the tests in clause 7 of the present document, the requirement applies at each receiver antenna connector for receivers with antenna diversity.

Receiver requirements are tested at the antenna connector, with the remaining receiver(s) disabled or their antenna connector(s) being terminated. If the manufacturer has declared the receiver paths to be equivalent, it is sufficient to apply the specified test signal at any one of the receiver antenna connectors.

5.14.2 Duplexers

Due to TDD operation, there is no need to use a duplexer in the BS.

5.14.3 Power supply options

If the BS is supplied with a number of different power supply configurations, it may not be necessary to test RF parameters for each of the power supply options, provided that it can be demonstrated that the range of conditions over which the equipment is tested is at least as great as the range of conditions due to any of the power supply configurations.

This applies particularly if a BS contains a DC rail which can be supplied either externally or from an internal mains power supply. In this case, the conditions of extreme power supply for the mains power supply options can be tested by testing only the external DC supply option. The range of DC input voltages for the test should be sufficient to verify the performance with any of the power supplies, over its range of operating conditions within the BS, including variation of mains input voltage, temperature and output current.

5.14.4 Ancillary RF amplifiers

The requirements of this TS shall be met with the ancillary RF amplifier fitted. At tests according to clause 6 and 7 for TX and RX respectively, the ancillary amplifier is connected to the BS by a connecting network (including any cable(s), attenuator(s), etc.) with applicable loss to make sure the appropriate operating conditions of the ancillary amplifier and

the BS. The applicable connecting network loss range is declared by the manufacturer. Other characteristics and the temperature dependence of the attenuation of the connecting network are neglected. The actual attenuation value of the connecting network is chosen for each test as one of the applicable extreme values. The lowest value is used unless otherwise stated.

Sufficient tests should be repeated with the ancillary amplifier fitted and, if it is optional, without the ancillary RF amplifier to verify that the BS meets the requirements of this TS in both cases.

5.14.5 BS using antenna arrays

A BS may be configured with a multiple antenna port connection for some or all of its TRXs or with an antenna array related to one cell (not one array per TRX). This subclause applies to a BS which meets at least one of the following conditions:

- The transmitter output signals from one or more TRX appear at more than one antenna port, or
- there is more than one receiver antenna port for a TRX or per cell and an input signal is required at more than one port for the correct operation of the receiver (NOTE: diversity reception does not meet this requirement) thus the outputs from the transmitters as well as the inputs to the receivers are directly connected to several antennas (known as "aircombining"), or

If a BS is used, in normal operation, in conjunction with an antenna system which contains filters or active elements which are necessary to meet the UTRA requirements, the tests of conformance may be performed on a system comprising the BS together with these elements, supplied separately for the purposes of testing. In this case, it must be demonstrated that the performance of the configuration under test is representative of the system in normal operation, and the conformance assessment is only applicable when the BS is used with the antenna system.

For testing of conformance of such a BS, the following procedure may be used:

5.14.5.1 Receiver tests

For each test, the test signals applied to the receiver antenna connectors shall be such that the sum of the powers of the signals applied equals the power of the test signal(s) specified in the test.

An example of a suitable test configuration is shown in figure 5.1.

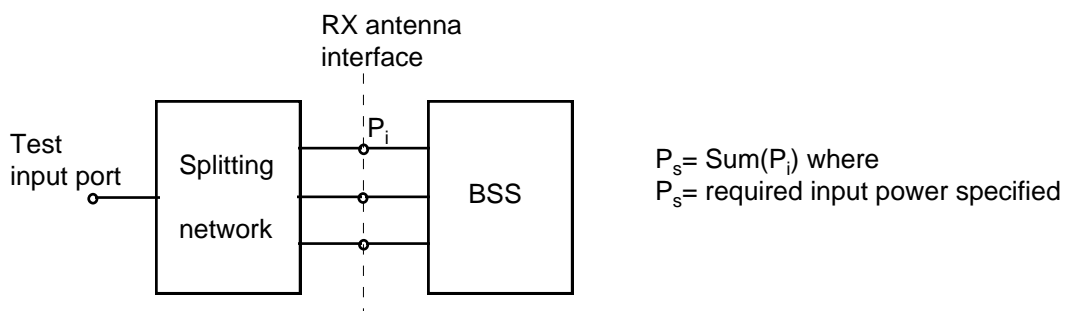

Figure 5.1: Receiver test set up

For spurious emissions from the receiver antenna connector, the test may be performed separately for each receiver antenna connector.

5.14.5.2 Transmitter tests

For each test, the conformance requirement shall be met by the sum of the signals emitted by each transmitter antenna connector. This may be assessed by separately measuring the signals emitted by each antenna connector and summing the results, or by combining the signals and performing a single measurement. The characteristics (e.g. amplitude and phase) of the combining network should be such that the power of the combined signal is maximised.

An example of a suitable test configuration is shown in figure 5.2.

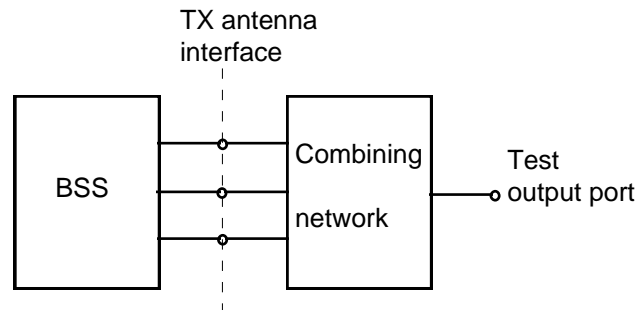

Figure 5.2: Transmitter test setup

For Intermodulation attenuation, the test may be performed separately for each transmitter antenna connector.

5.14.6 MIMO transmission

Unless otherwise stated, for the tests in clause 6 of the present document, the requirement applies for each transmitter antenna connector in the case of MIMO transmission.

Transmitter requirements are tested at the antenna connector, with the remaining antenna connector(s) being terminated. If the manufacturer has declared the transmitter paths to be equivalent, it is sufficient to measure the signal at any one of the transmitter antenna connectors.

5.15 Overview of the conformance test requirements

Tables 5.9, 5.10 and 5.11 give an overview of the conformance test requirements for the transmitter, the receiver and system performance, respectively. Requirements related to receive functionality for the BS under test do not apply for the case of MBSFN-only operation.

Table 5.9: Overview of the conformance tests requirements for the transmitter

Parameter	Subclause	Note
Maximum output power	6.2	manufacturer's declaration required
Frequency stability	6.3	manufacturer's declaration required
Output power dynamics	6.4	
Inner loop power control	6.4.1	
Power control steps	6.4.2	
Power control dynamic range	6.4.3	
Minimum output power	6.4.4	
Primary CCPCH power	6.4.5	
Differential accuracy of Primary CCPCH power	6.4.6	
Transmit OFF power	6.5.1	
Transmit ON/OFF time mask	6.5.2	
Output RF spectrum emissions	6.6	
Occupied bandwidth	6.6.1	
Out-of-band emission	6.6.2	
Spectrum emission mask	6.6.2.1	manufacturer's declaration required
Adjacent Channel Leakage power Ratio (ACLR)	6.6.2.2	manufacturer's declaration required
Spurious emissions	6.6.3	
Mandatory requirements	6.6.3.2.1	manufacturer's declaration required
Co-existence with GSM 900	6.6.3.2.2	manufacturer's declaration required
Co-existence with DCS 1800	6.6.3.2.3	manufacturer's declaration required
Co-existence with UTRA FDD	6.6.3.2.4	manufacturer's declaration required
Co-existence with unsynchronised TDD	6.6.3.2.5	manufacturer's declaration required
Transmit intermodulation	6.7	
Transmit modulation	6.8	
Modulation accuracy	6.8.1	
Peak code domain error	6.8.2	

Table 5.10: Overview of the conformance tests requirements for the receiver

Parameter	Subclause	Note
Reference sensitivity level	7.2	
Dynamic range	7.3	
Adjacent Channel Selectivity (ACS)	7.4	
Blocking characteristics	7.5	manufacturer's declaration required
Intermodulation characteristics	7.6	
Spurious emissions	7.7	

Table 5.11: Overview of the conformance test requirements for system performance

Parameter	Subclause	Note
Demodulation in static propagation conditions	8.2	
Demodulation of DCH	8.2.1	
Demodulation of DCH in multipath fading conditions	8.3	
Multipath fading Case 1	8.3.1	
Multipath fading Case 2	8.3.2	
Multipath fading Case 3	8.3.3	
Demodulation of DCH in high speed train conditions	8.3A	

5.16 Format and interpretation of tests

Each test in the following clauses has a standard format:

X Title

The title gives the name of the parameter to be tested.

X.1 Definition and applicability

This subclause gives the general definition of the parameter under consideration and specifies whether the test is applicable to all equipment or to a certain subset only.

X.2 Minimum Requirements

This subclause is an informative copy of the Minimum Requirements defined by the core specification.

In addition, this subclause contains the reference to the subclause of the 3GPP reference (or core) specification which defines the Minimum Requirements.

X.3 Test purpose

This subclause defines the purpose of the test.

X.4 Method of test

X.4.1 Initial conditions

This subclause defines the initial conditions for each test, including the test environment, the RF channels to be tested and the basic measurement setup.

X.4.2 Procedure

This subclause describes the steps necessary to perform the test and provides further details of the test definition like point of access (e.g. antenna port), domain (e.g. frequency-span), range, weighting (e.g. bandwidth), and algorithms (e.g. averaging).

X.5 Test Requirements

This subclause defines the pass/fail criteria for the equipment under test. See subclause 5.12 Interpretation of measurement results.

5.17 Regional requirements

Some requirements in this specification may only apply in certain regions. Table 5.12 lists all requirements that may be applied differently in different regions.

Table 5.12: List of regional requirements

Subclause number	Requirement	Comments
4.1	General	Only 3,84 Mcps and 7,68 Mcps TDD options are currently applicable in Japan.
4.2	Frequency bands	Some bands may be applied regionally.
5.1	Base station classes	Only requirements for Wide Area Base Stations shall be applied as regional requirements in Japan.
6.2.2	Maximum output power	In certain regions, the minimum requirement for normal conditions may apply also for some conditions outside the ranges defined for the Normal test environment in subclause 5.8.1
6.6.2.1.	Spectrum emission mask	The mask specified may be mandatory in certain regions. In other regions this mask may not be applied.
6.6.3.2.1.1	Spurious emissions (Category A)	These requirements shall be met in cases where Category A limits for spurious emissions, as defined in ITU-R Recommendation SM.329 [6], are applied.
6.6.3.2.1.2	Spurious emissions (Category B)	These requirements shall be met in cases where Category B limits for spurious emissions, as defined in ITU-R Recommendation SM.329 [6], are applied.
6.6.3.2.2.1	Co-existence with GSM, DCS, UTRA and/or E-UTRA -Operation in the same geographic area	This requirement may be applied for the protection of other BS or UE receivers when GSM, DCS, UTRA and/or E-UTRA BS are operating in the same geographic area with a UTRA TDD BS.
6.6.3.2.2.2	Co-existence with GSM, DCS, UTRA and/or E-UTRA -Co-located base stations	This requirement may be applied for the protection of other BS receivers when GSM, DCS UTRA and/or E-UTRA BS are co-located with a UTRA TDD BS.
6.6.3.2.5.1	Co-existence with unsynchronised TDD - Operation in the same geographic area	This requirement may be applied for the protection of TDD BS receivers in geographic areas in which unsynchronised TDD is deployed.
6.6.3.2.5.2	Co-existence with unsynchronised TDD - Co-located base stations	This requirement may be applied for the protection of TDD BS receivers when unsynchronised TDD BS are co-located.
6.6.3.2.6	Co-existence with PHS	This requirement may be applied for the protection of PHS in geographic areas in which both PHS and UTRA TDD are deployed.
7.5	Blocking characteristic	The requirement is applied according to what frequency bands in subclause 4.2 that are supported by the BS.
7.5	Blocking characteristics	This requirement may be applied for the protection of UTRA TDD BS receivers when UTRA TDD BS and GSM 900/DCS1800 BS are co-located.

5.18 Definition of Additive White Gaussian Noise (AWGN) Interferer

The minimum bandwidth of the AWGN interferer shall be 1,5 times chip rate of the radio access mode (e.g. 5,76 MHz for a chip rate of 3,84 Mcps and 1,92 MHz for a chip rate of 1,28 Mcps). The flatness across this minimum bandwidth shall be within $\pm 0,5$ dB, and the peak to average ratio at a probability of 0,001% shall exceed 10 dB.

5.19 Applicability of requirements

For BS that is UTRA TDD (single-RAT) capable only, the requirements in the present document are applicable and additional conformance to TS 37.141 [12] is optional. For a BS additionally conforming to TS 37.141 [12], conformance to some of the RF requirements in the present document can be demonstrated through the corresponding requirements in TS 37.141 [12] as listed in Table 5.13

Table 5.13: Alternative RF test requirements for a BS additionally conforming to TS 37.141 [12]

RF requirement	Clause in the present document	Alternative clause in TS 37.141 [16]
Base station output power	6.2.5	6.2.1 6.2.2
Transmit OFF power	6.5.1.5	6.4
Transmit ON/OFF time mask	6.5.2.5	6.4
Unwanted emissions		
Spectrum emission mask	6.6.2.1.5	6.6.2.5.1
Transmitter spurious emissions	6.6.3.5	6.6.1.5 (except for 6.6.1.5.3 and 6.6.1.5.4)
Transmitter intermodulation	6.7.5	6.7.5.1&6.7.5.3
Blocking	7.5.5	7.4.5.1 and 7.4.5.5
Out-of-band blocking	7.5.5	7.5.5.1
Co-location with other base stations	7.5.5	7.5.5.2
Receiver spurious emissions	7.7.5	7.6.5.1
Intermodulation	7.6.5	7.7.5.1

6 Transmitter characteristics

6.1 General

Unless otherwise stated, the requirements in clause 6 are expressed for a single transmitter antenna connector. In case of multi-carrier transmission with multiple transmitter antenna connectors or MIMO transmission, the requirements apply for each transmitter antenna connector.

A BS supporting MC-HSDPA transmits multiple carriers simultaneously on adjacent carrier frequencies.

Unless otherwise stated, all measurements shall be made at the BS antenna connector (test port A) with a full complement of transceivers for the configuration in normal operating conditions. If any external apparatus such as a TX amplifier, a filter or the combination of such devices is used, the tests according to subclauses 5.14.4 shall be performed to ensure that the requirements are met at test port B.

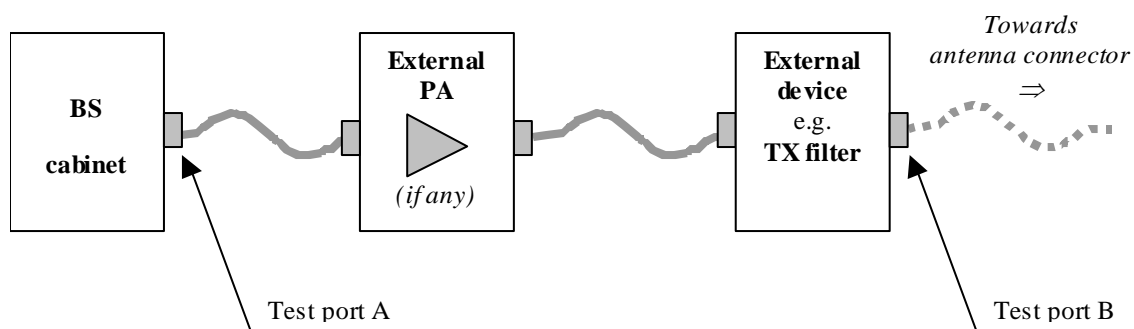
**Figure 6.1: Transmitter test ports**

6.1.1 IMB Test Models

The set-up of physical channels for IMB transmitter tests shall be according with the test models below.

6.1.1.1 IMB Test Model 1

This model shall apply to QPSK tests.

Table 6.0A: IMB Test Model 1 Active Channels

Type	Number of Channels	Time Activity	Fraction of Power (when channel is active) (%)	Level setting (per code) (dB)	Channelisati on Code Index
P-CCPCH+SCH	1	All slots	10	-10	1
P-CPICH	1	All slots	10	-10	0
T-CPICH	1	All slots	90	-12.22	1-15
S-CCPCH Frame Type 1 (SF=256, QPSK)	1	All slots	0.5	-23	3
S-CCPCH Frame Type 2 (SF=16, QPSK)	15	<u>Sub-frames</u> {0,1,2,3,4}	79.5	-12.75	1-15

The Base Station output power is set according to PRAT.

6.1.1.2 IMB Test Model 2

This model shall apply to 16QAM tests.

Table 6.0B: IMB Test Model 2 Active Channels

Type	Number of Channels	Time Activity	Fraction of Power (when channel is active) (%)	Level setting (per code) (dB)	Channelisati on Code Index
P-CCPCH+SCH	1	All slots	10	-10	1
P-CPICH	1	All slots	10	-10	0
T-CPICH	1	All slots	90	-12.22	1-15
S-CCPCH Frame Type 1 (SF=256, QPSK)	1	All slots	0.5	-23	3
S-CCPCH Frame Type 2 (SF=16, 16QAM)	15	<u>Sub-frames</u> {0,1,2,3,4}	79.5	-12.75	1-15

The Base Station output power is set according to PRAT.

6.2 Maximum output power

6.2.1 Definition and applicability

Maximum output power (P_{max}) and rated output power (PRAT) are defined in subclause 3.1.

The requirements in this subclause shall apply to Wide Area BS, Local Area BS and Home BS.

6.2.2 Minimum Requirements

In normal conditions, the base station maximum output power shall remain within +2 dB and -2 dB of the manufacturer's rated output power.

In extreme conditions, the base station maximum output power shall remain within +2,5 dB and -2,5 dB of the manufacturer's rated output power.

In certain regions, the minimum requirement for normal conditions may apply also for some conditions outside the ranges defined for the Normal test environment in subclause 5.9.1.

The normative reference for this requirement is TS 25.105 [1] subclause 6.2.1.1.

6.2.3 Test purpose

The test purpose is to verify the accuracy of the maximum output power across the frequency range and under normal and extreme conditions for all transmitters in the BS.

6.2.4 Method of test

6.2.4.1 Initial conditions

6.2.4.1.0 General test conditions

Test environment: normal; see subclause 5.9.1.

RF channels to be tested: B, M and T; see subclause 5.3.

In addition, on one UARFCN only, the test shall be performed under extreme power supply as defined in subclause 5.9.4.

NOTE: Tests under extreme power supply also test extreme temperature.

6.2.4.1.1 3,84 Mcps TDD option

- (1) The transmitter under test and all other transmitters of the base station (if any) are switched on.
- (2) The power of the transmitters not under test (if any) are controlled down.
- (3) Connect the power measuring equipment to the BS antenna connector.
- (4) Set the parameters of the transmitted signal according to table 6.1. For MBSFN IMB operation the set of parameters for the transmitted signals is according to IMB test model 1 in subclause 6.1.1.1.

Table 6.1: Parameters of the transmitted signal for maximum output power test

Parameter	Value/description
TDD Duty Cycle	TS i ; $i = 0, 1, 2, \dots, 14$: transmit, if i is even; receive, if i is odd.
Time slot carrying SCH	TS0
Time slots under test	TS i , i even and non zero
BS output power setting	PRAT
Number of DPCH in each time slot under test	9
Power of each DPCH	1/9 of Base Station output power
Data content of DPCH	real life (sufficient irregular)

6.2.4.1.2 1,28 Mcps TDD option

- (1) The transmitter under test and all other transmitters of the base station (if any) are switched on.
- (2) The power of the transmitters not under test (if any) are controlled down.
- (3) Connect the power measuring equipment to the BS antenna connector.
- (4) Set the parameters of the transmitted signal according to table 6.1A.

Table 6.1A: Parameters of the transmitted signal for maximum output power test for 1,28 Mcps TDD

Parameter	Value/description
TDD Duty Cycle	TS i ; $i = 0, 1, 2, 3, 4, 5, 6$: transmit, if i is 0,4,5,6; receive, if i is 1,2,3.
Time slots under test	TS4, TS5 and TS6
BS output power setting	PRAT
Number of DPCH in each time slot under test	8
Power of each DPCH	1/8 of Base Station output power
Data content of DPCH	real life (sufficient irregular)

6.2.4.1.3 7,68 Mcps TDD option

- (1) The transmitter under test and all other transmitters of the base station (if any) are switched on.
- (2) The power of the transmitters not under test (if any) are controlled down.
- (3) Connect the power measuring equipment to the BS antenna connector.
- (4) Set the parameters of the transmitted signal according to table 6.1AA.

Table 6.1AA: Parameters of the transmitted signal for maximum output power test

Parameter	Value/description
TDD Duty Cycle	TS i ; $i = 0, 1, 2, \dots, 14$: transmit, if i is even; receive, if i is odd.
Time slot carrying SCH	TS0
Time slots under test	TS i , i even and non zero
BS output power setting	PRAT
Number of DPCH in each time slot under test	9
Power of each DPCH	1/9 of Base Station output power
Data content of DPCH	real life (sufficient irregular)

6.2.4.2 Procedure

6.2.4.2.1 3,84 Mcps TDD option

- (1) Measure the output power of the BS signal.
- (2) Run step (1) for RF channels Low / Mid / High.

6.2.4.2.2 1,28 Mcps TDD option

- (1) Measure the output power of the BS signal.
- (2) Run step (1) for RF channels Low / Mid / High.

6.2.4.2.3 7,68 Mcps TDD option

- (1) Measure the output power of the BS signal.
- (2) Run step (1) for RF channels Low / Mid / High.

6.2.5 Test Requirements

NOTE: If the Test Requirement below differs from the Minimum Requirement, then the Test Tolerance applied for this test is non-zero. The Test Tolerance for this test is defined in subclause 5.1.1 and the explanation of how the Minimum Requirement has been relaxed by the Test Tolerance is given in Annex D.

In normal conditions, the measured output power, derived according to subclause 6.2.4.2, shall remain within +2,7 dB and -2,7 dB of the manufacturer's rated output power.

In extreme conditions, the measured output power, derived according to subclause 6.2.4.2, shall remain within +3,2 dB and -3,2 dB of the manufacturer's rated output power.

6.3 Frequency stability

6.3.1 Definition and applicability

Frequency stability is the ability of the BS to transmit at the assigned carrier frequency.

In this subclause, different requirements shall apply to Wide Area BS, Local Area BS and Home BS.

6.3.2 Minimum Requirements

The modulated carrier frequency of the BS is observed over a period of one timeslot. The frequency error shall be within the accuracy range given in Table 6.1B.

Table 6.1B: Frequency error Minimum Requirements

BS class	Accuracy
Wide Area BS	$\pm 0,05$ ppm
Local Area BS	$\pm 0,1$ ppm
Home BS	$\pm 0,25$ ppm

The normative reference for this requirement is TS 25.105 [1] subclause 6.3.1.1 for the 3,84 Mcps TDD option, subclause 6.3.1.2 for the 1,28 Mcps TDD option and subclause 6.3.1.3 for the 7,68 Mcps TDD option.

TS 25.105 subclause 6.3 specifies the additional requirement that the BS shall use the same frequency source for both RF generation and the chip clock. Compliance with this requirement is demonstrated by manufacturer's declaration; see subclause 5.4; a dedicated conformance test for this requirement is not defined.

6.3.3 Test purpose

The test purpose is to verify the accuracy of the carrier frequency across the frequency range and under normal and extreme conditions.

6.3.4 Method of test

6.3.4.1 Initial conditions

6.3.4.1.0 General test conditions

Test environment: normal; see subclause 5.9.1.

RF channels to be tested: B, M and T; see subclause 5.3.

The following additional test shall be performed:

On each of B, M and T, the test shall be performed under extreme power supply as defined in subclause 5.9.4.

NOTE: Tests under extreme power supply also test extreme temperature.

6.3.4.1.1 3,84 Mcps TDD option

- (1) The transmitter under test and all other transmitters of the base station (if any) are switched on.
- (2) The power of the transmitters not under test (if any) are controlled down.
- (3) Connect the tester to the BS antenna connector.
- (4) Set the parameters of the transmitted signal according to table 6.2. For MBSFN IMB operation the set of parameters for the transmitted signals is according to IMB test model 1 in subclause 6.1.1.1.

Table 6.2: Parameters of the transmitted signal for frequency stability test

Parameter	Value/description
TDD Duty Cycle	TS i ; $i = 0, 1, 2, \dots, 14$: transmit, if i is even; receive, if i is odd.
Time slot carrying SCH	TS0
Time slots under test	TS i , i even and non zero
Number of DPCH in each time slot under test	1
BS output power setting	PRAT
Data content of DPCH	real life (sufficient irregular)

6.3.4.1.2 1,28 Mcps TDD option

- (1) The transmitter under test and all other transmitters of the base station (if any) are switched on.
- (2) The power of the transmitters not under test (if any) are controlled down.
- (3) Connect the tester to the BS antenna connector.
- (4) Set the parameters of the transmitted signal according to table 6.2A.

Table 6.2A: Parameters of the transmitted signal for Frequency stability test for 1,28 Mcps TDD

Parameter	Value/description
TDD Duty Cycle	TS i ; $i = 0, 1, 2, \dots, 6$: transmit, if i is 0, 4,5,6; receive, if i is 1,2,3.
Time slots under test	TS4, TS5 and TS6
Number of DPCH in each time slot under test	1
BS output power setting	PRAT
Data content of DPCH	real life (sufficient irregular)

6.3.4.1.3 7,68 Mcps TDD option

- (1) The transmitter under test and all other transmitters of the base station (if any) are switched on.
- (2) The power of the transmitters not under test (if any) are controlled down.
- (3) Connect the tester to the BS antenna connector.
- (4) Set the parameters of the transmitted signal according to table 6.2AA.

Table 6.2AA: Parameters of the transmitted signal for frequency stability test

Parameter	Value/description
TDD Duty Cycle	TS i ; $i = 0, 1, 2, \dots, 14$: transmit, if i is even; receive, if i is odd.
Time slot carrying SCH	TS0
Time slots under test	TS i , i even and non zero
Number of DPCH in each time slot under test	1
BS output power setting	PRAT
Data content of DPCH	real life (sufficient irregular)

6.3.4.2 Procedure

- (1) Measure the frequency error Δf across one burst (time slot), by applying the global in-channel Tx test method described in Annex C.
- (2) Repeat step (1) for 200 bursts (time slots).
- (3) Run steps (1) and (2) for RF channels Low / Mid / High.

6.3.5 Test Requirements

NOTE: If the Test Requirement below differs from the Minimum Requirement, then the Test Tolerance applied for this test is non-zero. The Test Tolerance for this test is defined in subclause 5.1.1 and the explanation of how the Minimum Requirement has been relaxed by the Test Tolerance is given in Annex D.

For all measured bursts (time slots), the frequency error, derived according to subclause 6.3.4.2, shall be within the accuracy range given in table 6.2B.

Table 6.2B: Frequency error Test Requirements

BS class	Accuracy
Wide Area BS	$\pm (0,05 \text{ ppm} + 12 \text{ Hz})$
Local Area BS	$\pm (0,1 \text{ ppm} + 12 \text{ Hz})$
Home BS	$\pm (0,25 \text{ ppm} + 12 \text{ Hz})$

6.4 Output power dynamics

6.4.1 Inner loop power control

Inner loop power control is the ability of the BS transmitter to adjust its code domain power in response to the UL received signal.

For inner loop correction on the Downlink Channel, the base station adjusts the code domain power of a power controlled CCTrCH in response to each valid power control bit received from the UE on the Uplink Traffic Channel based on the mapping of the TPC bits in uplink CCTrCH to downlink CCTrCH. Inner loop control is based on SIR measurements at the UE receiver, and the corresponding TPC commands are generated by the UE.

6.4.2 Power control steps

6.4.2.1 Definition and applicability

The power control step is the step change in the DL code domain power in response to a TPC message from the UE.

The requirements in this subclause shall apply to both Wide Area BS and Local Area BS.

6.4.2.2 Minimum Requirements

The power control step sizes in the DL shall be 1 dB, 2 dB and 3 dB.

The tolerance of the code domain power and the greatest average rate of change in code domain power due to the power control step shall be within the range shown in Table 6.3.

Table 6.3: Power control step size tolerance

Step size	Tolerance	Range of average rate of change in code domain power per 10 steps	
		Minimum	maximum
1 dB	$\pm 0,5$ dB	± 8 dB	± 12 dB
2 dB	$\pm 0,75$ dB	± 16 dB	± 24 dB
3 dB	± 1 dB	± 24 dB	± 36 dB

The normative reference for this requirement is TS 25.105 [1] subclause 6.4.2.1.

6.4.2.3 Test purpose

The DL power control is applied to adjust the BS code domain power to a value that is sufficiently high to generate a SIR at the UE receiver equal to the target SIR, while limiting the intercell interference.

The test purpose is to verify the ability of the BS to interpret received TPC commands in a correct way and to adjust its code domain power according to these commands with the specified accuracy.

6.4.2.4 Method of test

6.4.2.4.1 Initial conditions

6.4.2.4.1.0 General test conditions

Test environment: normal; see subclause 5.9.1.

RF channels to be tested: B, M and T; see subclause 5.3.

6.4.2.4.1.1 3,84 Mcps TDD option

- (1) Connect the BS tester to the antenna connector of the BS under test.
- (2) Disable closed loop power control in the BS under test.
- (3) Set the initial parameters of the BS transmitted signal according to table 6.4.
- (4) Operate the BS in such a mode that it is able to interpret received TPC commands.
- (5) Start BS transmission.

NOTE: The BS tester used for this test must have the ability:

- to analyze the output signal of the BS under test with respect to code domain power, by applying the global in-channel Tx test method described in Annex C;
- to simulate an UE with respect to the generation of TPC commands embedded in a valid UE signal.

Table 6.4: Initial parameters of the BS transmitted signal for power control steps test

Parameter	Value/description
TDD Duty Cycle	TS i ; $i = 0, 1, 2, \dots, 14$: transmit, if i is even; receive, if i is odd.
Time slot carrying SCH	TS0
Time slots under test	TS i , i even and non zero
Number of DPCH in each time slot under test	1
DPCH power	Minimum
Data content of DPCH	real life (sufficient irregular)

6.4.2.4.1.2 1,28 Mcps TDD option

- (1) Connect the BS tester to the antenna connector of the BS under test.
- (2) Disable closed loop power control in the BS under test.
- (3) Set the initial parameters of the BS transmitted signal according to table 6.4A.
- (4) Operate the BS in such a mode that it is able to interpret received TPC commands.
- (5) Start BS transmission.

NOTE: The BS tester used for this test must have the ability

- to analyze the output signal of the BS under test with respect to code domain power, by applying the global in-channel Tx test method described in Annex C;
- to simulate an UE with respect to the generation of TPC commands embedded in a valid UE signal.

Table 6.4A: Initial parameters of the BS transmitted signal for power control steps test for 1,28 Mcps TDD

Parameter	Value/description
TDD Duty Cycle	TS i ; $i = 0, 1, 2, \dots, 6$: transmit, if i is 0, 4,5,6; receive, if i is 1,2,3.
Time slots under test	TS4, TS5 and TS6
Number of DPCH in each time slot under test	1
DPCH power	Minimum
Data content of DPCH	real life (sufficient irregular)

6.4.2.4.1.3 7,68 Mcps TDD option

- (1) Connect the BS tester to the antenna connector of the BS under test.
- (2) Disable closed loop power control in the BS under test.
- (3) Set the initial parameters of the BS transmitted signal according to table 6.4B.
- (4) Operate the BS in such a mode that it is able to interpret received TPC commands.
- (5) Start BS transmission.

NOTE: The BS tester used for this test must have the ability:

- to analyze the output signal of the BS under test with respect to code domain power, by applying the global in-channel Tx test method described in Annex C;
- to simulate an UE with respect to the generation of TPC commands embedded in a valid UE signal.

Table 6.4B: Initial parameters of the BS transmitted signal for power control steps test

Parameter	Value/description
TDD Duty Cycle	TS i ; $i = 0, 1, 2, \dots, 14$: transmit, if i is even; receive, if i is odd.
Time slot carrying SCH	TS0
Time slots under test	TS i , i even and non zero
Number of DPCH in each time slot under test	1
DPCH power	Minimum
Data content of DPCH	real life (sufficient irregular)

6.4.2.4.2 Procedure

6.4.2.4.2.1 3,84 Mcps TDD option

- (1) Configure the BS transmitter to enable power control steps of size 1 dB.
- (2) Set the BS tester to produce a sequence of TPC commands related to the active DPCH. This sequence shall be transmitted to the BS within the odd time slots TS i (receive time slots of the BS) and shall consist of a series of TPC commands with content "Increase Tx power", followed by a series of TPC commands with content "Decrease Tx power". Each of these series should be sufficiently long so that the code domain power of the active DPCH is controlled to reach its maximum and its minimum, respectively.
- (3) Measure the code domain power of the active DPCH over the 2464 active chips of each even time slot TS i (this excludes the guard period) by applying the global in-channel Tx test method described in Annex C.
- (4) Based on the measurement made in step (3), calculate the power control step sizes and the average rate of change per 10 steps.
- (5) Configure the BS transmitter to enable power control steps of 2 dB and of 3 dB, respectively, and repeat steps (2) to (4).

6.4.2.4.2.2 1,28 Mcps TDD option

- (1) Configure the BS transmitter to enable power control steps of size 1 dB.
- (2) Set the BS tester to produce a sequence of TPC commands related to the active DPCH. This sequence shall be transmitted to the BS within receive time TS i slots of the BS and shall consist of a series of TPC commands with content "Increase Tx power", followed by a series of TPC commands with content "Decrease Tx power". Each of these series should be sufficiently long so that the code domain power of the active DPCH is controlled to reach its maximum and its minimum, respectively.
- (3) Measure the code domain power of the active DPCH over the 848 active chips of each transmit time slot TS i of the BS (this excludes the guard period) by applying the global in-channel Tx test method described in Annex C.
- (4) Based on the measurement made in step (3), calculate the power control step sizes and the average rate of change per 10 steps.
- (5) Configure the BS transmitter to enable power control steps of 2 dB and of 3 dB, respectively, and repeat steps (2) to (4).

6.4.2.4.2.3 7,68 Mcps TDD option

- (1) Configure the BS transmitter to enable power control steps of size 1 dB.
- (2) Set the BS tester to produce a sequence of TPC commands related to the active DPCH. This sequence shall be transmitted to the BS within the odd time slots TS i (receive time slots of the BS) and shall consist of a series of TPC commands with content "Increase Tx power", followed by a series of TPC commands with content "Decrease Tx power". Each of these series should be sufficiently long so that the code domain power of the active DPCH is controlled to reach its maximum and its minimum, respectively.

- (3) Measure the code domain power of the active DPCH over the 4928 active chips of each even time slot TS i (this excludes the guard period) by applying the global in-channel Tx test method described in Annex C.
- (4) Based on the measurement made in step (3), calculate the power control step sizes and the average rate of change per 10 steps.
- (5) Configure the BS transmitter to enable power control steps of 2 dB and of 3 dB, respectively, and repeat steps (2) to (4).

6.4.2.5 Test Requirements

NOTE: If the Test Requirements below differ from the Minimum Requirement, then the Test Tolerance applied for this test is non-zero. The Test Tolerance for this test is defined in subclause 5.11 and the explanation of how the Minimum Requirement has been relaxed by the Test Tolerance is given in Annex D.

6.4.2.5.1 3,84 Mcps TDD option

For all measurements, the tolerance of the power control step sizes and the average rate of change per 10 steps shall be within the limits given in Table 6.5.

Table 6.5: Test Requirements for power control step size tolerance

Step size	Single step tolerance	Range of average rate of change in code domain power per 10 steps	
		Minimum	maximum
1dB	$\pm 0,6$ dB	$\pm 7,7$ dB	$\pm 12,3$ dB
2dB	$\pm 0,85$ dB	$\pm 15,7$ dB	$\pm 24,3$ dB
3dB	$\pm 1,1$ dB	$\pm 23,7$ dB	$\pm 36,3$ dB

In case, the power control step size is set to 3 dB, the number of power control steps feasible within the power control dynamic range of the BS under test may be less than 10. In this case, the evaluation of the average rate of change in code domain power shall be based on the number of power control steps actually feasible, and the permitted range of average rate of change shall be reduced compared to the values given in table 6.5 in proportion to the ratio (number of power control steps actually feasible / 10).

EXAMPLE: If the number of power control steps actually feasible is 9, the minimum and maximum value of the range of average rate of change in code domain power are given by $\pm 21,3$ dB and $\pm 32,7$ dB, respectively.

6.4.2.5.2 1,28 Mcps TDD option

For all measurements, the tolerance of the power control step sizes and the average rate of change per 10 steps shall be within the limits given in Table 6.5.

In case, the power control step size is set to 3 dB, the number of power control steps feasible within the power control dynamic range of the BS under test may be less than 10. In this case, the evaluation of the average rate of change in code domain power shall be based on the number of power control steps actually feasible, and the permitted range of average rate of change shall be reduced compared to the values given in table 6.5 in proportion to the ratio (number of power control steps actually feasible / 10).

EXAMPLE: If the number of power control steps actually feasible is 9, the minimum and maximum value of the range of average rate of change in code domain power are given by 21,6 dB and 32,4 dB, respectively.

6.4.2.5.3 7,68 Mcps TDD option

For all measurements, the tolerance of the power control step sizes and the average rate of change per 10 steps shall be within the limits given in Table 6.5.

In case, the power control step size is set to 3 dB, the number of power control steps feasible within the power control dynamic range of the BS under test may be less than 10. In this case, the evaluation of the average rate of change in

code domain power shall be based on the number of power control steps actually feasible, and the permitted range of average rate of change shall be reduced compared to the values given in table 6.5 in proportion to the ratio (number of power control steps actually feasible / 10).

EXAMPLE: If the number of power control steps actually feasible is 9, the minimum and maximum value of the range of average rate of change in code domain power are given by $\pm 21,3$ dB and $\pm 32,7$ dB, respectively.

6.4.3 Power control dynamic range

6.4.3.1 Definition and applicability

The power control dynamic range is the difference between the maximum and the minimum code domain power of one power controlled code channel for a specified reference condition.

The requirements in this subclause shall apply to both Wide Area BS and Local Area BS.

6.4.3.2 Minimum Requirements

The DL power control dynamic range shall be greater than or equal to 30 dB.

The normative reference for this requirement is TS 25.105 [1] subclause 6.4.3.1.

6.4.3.3 Test purpose

The test purpose is to verify the ability of the BS to control the code domain power of a single code signal over the specified dynamic range.

6.4.3.4 Method of test

6.4.3.4.1 Initial conditions

6.4.3.4.1.0 General test conditions

Test environment: normal; see subclause 5.9.1.

RF channels to be tested: B, M and T; see subclause 5.3.

6.4.3.4.1.1 3,84 Mcps TDD option

- (1) Connect the BS tester to the antenna connector of the BS under test.
- (2) Set the parameters of the BS transmitted signal according to table 6.6.
- (3) Operate the BS in such a mode that it is able to interpret received TPC commands
- (4) Start BS transmission.

NOTE: The BS tester used for this test must have the ability:

- to analyze the output signal of the BS under test with respect to code domain power, by applying the global in-channel Tx test method described in Annex C;
- to simulate an UE with respect to the generation of TPC commands embedded in a valid UE signal.

Table 6.6: Parameters of the BS transmitted signal for power control dynamic range test

Parameter	Value/description
TDD Duty Cycle	TS i ; $i = 0, 1, 2, \dots, 14$: transmit, if i is even; receive, if i is odd.
Time slot carrying SCH	TS0
Time slots under test	TS i , i even and non zero
Number of DPCH in each time slot under test	1
Data content of DPCH	real life (sufficient irregular)

6.4.3.4.1.2 1,28 Mcps TDD option

- (1) Connect the BS tester to the antenna connector of the BS under test.
- (2) Set the parameters of the BS transmitted signal according to table 6.6A.
- (3) Operate the BS in such a mode that it is able to interpret received TPC commands
- (4) Start BS transmission.

NOTE: The BS tester used for this test must have the ability

- to analyze the output signal of the BS under test with respect to code domain power, by applying the global in-channel Tx test method described in Annex C;
- to simulate an UE with respect to the generation of TPC commands embedded in a valid UE signal.

Table 6.6A: Parameters of the BS transmitted signal for power control dynamic range test for 1,28 Mcps TDD

Parameter	Value/description
TDD Duty Cycle	TS i ; $i = 0, 1, 2, \dots, 6$: transmit, if i is 0, 4,5,6; receive, if i is 1,2,3.
Time slots under test	TS4, TS5 and TS6
Number of DPCH in each time slot under test	1
Data content of DPCH	real life (sufficient irregular)

6.4.3.4.1.3 7,68 Mcps TDD option

- (1) Connect the BS tester to the antenna connector of the BS under test.
- (2) Set the parameters of the BS transmitted signal according to table 6.6B.
- (3) Operate the BS in such a mode that it is able to interpret received TPC commands
- (4) Start BS transmission.

NOTE: The BS tester used for this test must have the ability:

- to analyze the output signal of the BS under test with respect to code domain power, by applying the global in-channel Tx test method described in Annex C;
- to simulate an UE with respect to the generation of TPC commands embedded in a valid UE signal.

Table 6.6B: Parameters of the BS transmitted signal for power control dynamic range test

Parameter	Value/description
TDD Duty Cycle	TS i ; $i = 0, 1, 2, \dots, 14$: transmit, if i is even; receive, if i is odd.
Time slot carrying SCH	TS0
Time slots under test	TS i , i even and non zero
Number of DPCH in each time slot under test	1
Data content of DPCH	real life (sufficient irregular)

6.4.3.4.2 Procedure

6.4.3.4.2.1 3,84 Mcps TDD option

- (1) Configure the BS transmitter to enable power control steps of size 1 dB.
- (2) Set the BS tester to produce a sequence of TPC commands related to the active DPCH, with content "Increase Tx power". This sequence shall be sufficiently long so that the code domain power of the active DPCH is controlled to reach its maximum, and shall be transmitted to the BS within the odd time slots TS i (receive time slots of the BS).
- (3) Measure the code domain power of the active DPCH over the 2464 active chips of an even time slot TS i (this excludes the guard period) by applying the global in-channel Tx test method described in Annex C.
- (4) Set the BS tester to produce a sequence of TPC commands related to the active DPCH, with content "Decrease Tx power". This sequence shall be sufficiently long so that the code domain power of the active DPCH is controlled to reach its minimum, and shall be transmitted to the BS within the odd time slots TS i (receive time slots of the BS).
- (5) Measure the code domain power of the active DPCH over the 2464 active chips of an even time slot TS i (this excludes the guard period) by applying the global in-channel Tx test method described in Annex C.
- (6) Determine the power control dynamic range by calculating the difference between the maximum code domain power measured in step (3) and the minimum code domain power measured in step (5).
- (7) Configure the BS transmitter to enable power control steps of 2 dB and of 3 dB, respectively, and repeat steps (2) to (6).

6.4.3.4.2.2 1,28 Mcps TDD option

- (1) Configure the BS transmitter to enable power control steps of size 1 dB.
- (2) Set the BS tester to produce a sequence of TPC commands related to the active DPCH, with content "Increase Tx power". This sequence shall be sufficiently long so that the code domain power of the active DPCH is controlled to reach its maximum, and shall be transmitted to the BS within the receive time slots TS i of the BS.
- (3) Measure the code domain power of the active DPCH over the 848 active chips of a transmit time slot TS i of the BS (this excludes the guard period) by applying the global in-channel Tx test method described in Annex C.
- (4) Set the BS tester to produce a sequence of TPC commands related to the active DPCH, with content "Decrease Tx power". This sequence shall be sufficiently long so that the code domain power of the active DPCH is controlled to reach its minimum, and shall be transmitted to the BS within the receive time slots TS i of the BS.
- (5) Measure the code domain power of the active DPCH over the 848 active chips of a transmit time slot TS i of the BS (this excludes the guard period) by applying the global in-channel Tx test method described in Annex C.
- (6) Determine the power control dynamic range by calculating the difference between the maximum code domain power measured in step (3) and the minimum code domain power measured in step (5).
- (7) Configure the BS transmitter to enable power control steps of 2 dB and of 3 dB, respectively, and repeat steps (2) to (6).

6.4.3.4.2.3 7,68 Mcps TDD option

- (1) Configure the BS transmitter to enable power control steps of size 1 dB.
- (2) Set the BS tester to produce a sequence of TPC commands related to the active DPCH, with content "Increase Tx power". This sequence shall be sufficiently long so that the code domain power of the active DPCH is controlled to reach its maximum, and shall be transmitted to the BS within the odd time slots TS_i (receive time slots of the BS).
- (3) Measure the code domain power of the active DPCH over the 4928 active chips of an even time slot TS_i (this excludes the guard period) by applying the global in-channel Tx test method described in Annex C.
- (4) Set the BS tester to produce a sequence of TPC commands related to the active DPCH, with content "Decrease Tx power". This sequence shall be sufficiently long so that the code domain power of the active DPCH is controlled to reach its minimum, and shall be transmitted to the BS within the odd time slots TS_i (receive time slots of the BS).
- (5) Measure the code domain power of the active DPCH over the 4928 active chips of an even time slot TS_i (this excludes the guard period) by applying the global in-channel Tx test method described in Annex C.
- (6) Determine the power control dynamic range by calculating the difference between the maximum code domain power measured in step (3) and the minimum code domain power measured in step (5).
- (7) Configure the BS transmitter to enable power control steps of 2 dB and of 3 dB, respectively, and repeat steps (2) to (6).

6.4.3.5 Test Requirements

NOTE: If the Test Requirement below differs from the Minimum Requirement, then the Test Tolerance applied for this test is non-zero. The Test Tolerance for this test is defined in subclause 5.11 and the explanation of how the Minimum Requirement has been relaxed by the Test Tolerance is given in Annex D.

The power control dynamic range derived according to subclause 6.4.3.4.2 shall be greater than or equal to 29,7 dB

6.4.4 Minimum output power

6.4.4.1 Definition and applicability

The minimum controlled output power of the BS is when the power is set to a minimum value.

The requirements in this subclause shall apply to both Wide Area BS and Local Area BS.

6.4.4.2 Minimum Requirements

The DL minimum output power shall be less than or equal to:

Maximum output power - 30 dB.

The normative reference for this requirement is TS 25.105 [1] subclause 6.4.4.1.

6.4.4.3 Test purpose

The test purpose is to verify the ability of the BS to reduce its output power to a specified value.

6.4.4.4 Method of test

6.4.4.4.1 Initial conditions

6.4.4.4.1.0 General test conditions

Test environment: normal; see subclause 5.9.1.

RF channels to be tested: B, M and T; see subclause 5.3.

6.4.4.4.1.1 3,84 Mcps TDD option

- (1) Connect the BS tester to the antenna connector of the BS under test.
- (2) Set the parameters of the BS transmitted signal according to table 6.7.
- (3) Operate the BS in such a mode that it is able to interpret received TPC commands
- (4) Start BS transmission.

NOTE: The BS tester used for this test must have the ability:

- to analyse the output signal of the BS under test with respect to mean power;
- to simulate an UE with respect to the generation of TPC commands embedded in a valid UE signal.

Table 6.7: Parameters of the BS transmitted signal for minimum power test

Parameter	Value/description
TDD Duty Cycle	TS i ; $i = 0, 1, 2, \dots, 14$: transmit, if i is even; receive, if i is odd.
Time slot carrying SCH	TS0
Time slots under test	TS i , i even and non zero
Number of DPCH in each time slot under test	1
Data content of DPCH	real life (sufficient irregular)

6.4.4.4.1.2 1,28 Mcps TDD option

- (1) Connect the BS tester to the antenna connector of the BS under test.
- (2) Set the parameters of the BS transmitted signal according to table 6.7A.
- (3) Operate the BS in such a mode that it is able to interpret received TPC commands
- (4) Start BS transmission.

NOTE: The BS tester used for this test must have the ability

- to analyse the output signal of the BS under test with respect to mean power;
- to simulate an UE with respect to the generation of TPC commands embedded in a valid UE signal.

Table 6.7A: Parameters of the BS transmitted signal for minimum power test for 1,28 Mcps TDD

Parameter	Value/description
TDD Duty Cycle	TS i ; $i = 0, 1, 2, 3, 4, 5, 6$: transmit, if i is 0,4,5,6; receive, if i is 1,2,3.
Time slots under test	TS4, TS5 and TS6
BS output power setting	PRAT
Number of DPCH in each time slot under test	1
Power of each DPCH	PRAT
Data content of DPCH	real life (sufficient irregular)

6.4.4.4.1.3 7,68 Mcps TDD option

- (1) Connect the BS tester to the antenna connector of the BS under test.
- (2) Set the parameters of the BS transmitted signal according to table 6.7B.

- (3) Operate the BS in such a mode that it is able to interpret received TPC commands
- (4) Start BS transmission.

NOTE: The BS tester used for this test must have the ability:

- to analyse the output signal of the BS under test with respect to mean power;
- to simulate an UE with respect to the generation of TPC commands embedded in a valid UE signal.

Table 6.7B: Parameters of the BS transmitted signal for minimum power test

Parameter	Value/description
TDD Duty Cycle	TS i ; $i = 0, 1, 2, \dots, 14$: transmit, if i is even; receive, if i is odd.
Time slot carrying SCH	TS0
Time slots under test	TS i , i even and non zero
Number of DPCH in each time slot under test	1
Data content of DPCH	real life (sufficient irregular)

6.4.4.4.2 Procedure

6.4.4.4.2.1 3,84 Mcps TDD option

- (1) Configure the BS transmitter to enable power control steps of size 1 dB.
- (2) Set the BS tester to produce a sequence of TPC commands related to all active DPCH, with content "Decrease Tx power". This sequence shall be sufficiently long so that the output power of all active DPCH is controlled to reach its minimum, and shall be transmitted to the BS within the odd time slots TS i (receive time slots of the BS).
- (3) Measure the power of the BS output signal over the 2464 active chips of an even and non zero time slot TS i (this excludes the guard period), and with a measurement filter that has a RRC filter response with a roll off $\alpha = 0,22$ and a bandwidth equal to the chip rate. The power is determined by calculating the RMS value of the signal samples at the measurement filter output taken at the decision points.
- (4) Configure the BS transmitter to enable power control steps of 2 dB and of 3 dB, respectively, and repeat steps (2) and (3).

6.4.4.4.2.2 1,28 Mcps TDD option

- (1) Configure the BS transmitter to enable power control steps of size 1 dB.
- (2) Set the BS tester to produce a sequence of TPC commands related to all active DPCH, with content "Decrease Tx power". This sequence shall be sufficiently long so that the output power of all active DPCH is controlled to reach its minimum, and shall be transmitted to the BS within the receive time slots TS i of the BS.
- (3) Measure the power of the BS output signal over the 848 active chips of a time slot TS i (this excludes the guard period), and with a measurement filter that has a RRC filter response with a roll off $\alpha = 0,22$ and a bandwidth equal to the chip rate. The power is determined by calculating the RMS value of the signal samples at the measurement filter output taken at the decision points.
- (4) Configure the BS transmitter to enable power control steps of 2 dB and of 3 dB, respectively, and repeat steps (2) and (3).

6.4.4.4.2.3 7,68 Mcps TDD option

- (1) Configure the BS transmitter to enable power control steps of size 1 dB.
- (2) Set the BS tester to produce a sequence of TPC commands related to all active DPCH, with content "Decrease Tx power". This sequence shall be sufficiently long so that the output power of all active DPCH is controlled to

reach its minimum, and shall be transmitted to the BS within the odd time slots TS i (receive time slots of the BS).

- (3) Measure the power of the BS output signal over the 4928 active chips of an even and non zero time slot TS i (this excludes the guard period), and with a measurement filter that has a RRC filter response with a roll off $\alpha = 0,22$ and a bandwidth equal to the chip rate. The power is determined by calculating the RMS value of the signal samples at the measurement filter output taken at the decision points.
- (4) Configure the BS transmitter to enable power control steps of 2 dB and of 3 dB, respectively, and repeat steps (2) and (3).

6.4.4.5 Test Requirements

NOTE: If the Test Requirement below differs from the Minimum Requirement, then the Test Tolerance applied for this test is non-zero. The Test Tolerance for this test is defined in subclause 5.1.1 and the explanation of how the Minimum Requirement has been relaxed by the Test Tolerance is given in Annex D.

For all measurements, the minimum output power derived in step (4) of subclause 6.4.4.2 shall be at least 29,3 dB below the maximum output power; see 6.2.

6.4.5 Primary CCPCH power

6.4.5.1 Definition and applicability

Primary CCPCH power is the code domain power of the Primary Common Control Physical Channel averaged over the transmit timeslot. Primary CCPCH power is signalled on the BCH.

The requirements in this subclause shall apply to both Wide Area BS and Local Area BS.

6.4.5.2 Minimum Requirements

The error between the BCH-broadcast value of the Primary CCPCH power and the Primary CCPCH code domain power averaged over the timeslot shall not exceed the values in table 6.8. The error is a function of the output power averaged over the timeslot, P_{out} , and the manufacturer's rated output power, PRAT.

Table 6.8: Errors between Primary CCPCH power and the broadcast value

Output power in slot, dB	CCPCH power tolerance
$PRAT - 3 < P_{out} \leq PRAT + 2$	+/- 2,5 dB
$PRAT - 6 < P_{out} \leq PRAT - 3$	+/- 3,5 dB
$PRAT - 13 < P_{out} \leq PRAT - 6$	+/- 5 dB

The normative reference for this requirement is TS 25.105 [1] subclause 6.4.5.

6.4.5.3 Test purpose

The code domain power of the Primary CCPCH received by the UE, together with the information on the Primary CCPCH nominal output power signaled on the BCH, are used by the UE for path loss estimation and adjustment of its own transmit power. Therefore, deviations of the Primary CCPCH code domain power from its nominal value are transposed by the UE into deviations from the wanted output power of the UE.

The test purpose is to verify that the Primary CCPCH code domain power remains within its specified tolerances.

6.4.5.4 Method of test

6.4.5.4.1 Initial conditions

6.4.5.4.1.0 General test conditions

Test environment: normal; see subclause 5.9.1.

RF channels to be tested: B, M and T; see subclause 5.3.

6.4.5.4.1.1 3,84 Mcps TDD option

- (1) Connect the BS tester to the antenna connector of the BS under test. The BS tester must have the ability to analyze the output signal of the BS under test with respect to code domain power, by applying the global in-channel Tx test method described in Annex C.
- (2) Set the parameters of the BS transmitted signal according to table 6.9.

Table 6.9: Parameters of the BS transmitted signal for Primary CCPCH power testing

Parameter	Value/description
TDD Duty Cycle	TS i ; $i = 0, 1, 2, \dots, 14$: transmit, if i is even; receive, if i is odd.
Time slots carrying PCCPCH	TS 0 and TS 8
Number of additional DPCH in TS 0 and TS 8	3
BS output power setting	PRAT
Relative power of PCCPCH	$\frac{1}{4}$ of BS output power
Relative power of each DPCH in TS 0 and TS 8	$\frac{1}{4}$ of BS output power
Data content of DPCH	real life (sufficient irregular)

6.4.5.4.1.2 1,28 Mcps TDD option

- (1) Connect the BS tester to the antenna connector of the BS under test. The BS tester must have the ability to analyze the output signal of the BS under test with respect to code domain power, by applying the global in-channel Tx test method described in Annex C.
- (2) Set the parameters of the BS transmitted signal according to table 6.9A.

Table 6.9A: Parameters of the BS transmitted signal for Primary CCPCH power testing for 1,28 Mcps TDD

Parameter	Value/description
TDD Duty Cycle	TS i ; $i = 0, 1, 2, \dots, 6$: transmit, if i is 0,4,5,6; receive, if i is 1,2,3.
Time slots carrying PCCPCH	TS 0
BS output power setting	PRAT
Relative power of PCCPCH	$\frac{1}{2}$ of BS output power
Data content of DPCH	real life (sufficient irregular)

6.4.5.4.1.3 7,68 Mcps TDD option

- (1) Connect the BS tester to the antenna connector of the BS under test. The BS tester must have the ability to analyze the output signal of the BS under test with respect to code domain power, by applying the global in-channel Tx test method described in Annex C.
- (2) Set the parameters of the BS transmitted signal according to table 6.9B.

Table 6.9B: Parameters of the BS transmitted signal for Primary CCPCH power testing

Parameter	Value/description
TDD Duty Cycle	TS i ; $i = 0, 1, 2, \dots, 14$: transmit, if i is even; receive, if i is odd.
Time slots carrying PCCPCH	TS 0 and TS 8
Number of additional DPCH in TS 0 and TS 8	3
BS output power setting	PRAT
Relative power of PCCPCH	$\frac{1}{4}$ of BS output power
Relative power of each DPCH in TS 0 and TS 8	$\frac{1}{4}$ of BS output power
Data content of DPCH	real life (sufficient irregular)

6.4.5.4.2 Procedure

6.4.5.4.2.1 3,84 Mcps TDD option

- (1) Measure the PCCPCH code domain power in TS 0 and TS 8 by applying the global in-channel Tx test method described in Annex C.
- (2) Reduce the base station output power by 2 dB, 5 dB and 13 dB, without changing the relative powers of the PCCPCH and the DPCHs, and repeat step (1) for each output power setting.

6.4.5.4.2.2 1,28 Mcps TDD option

- (1) Measure the PCCPCH code domain power in TS 0 by applying the global in-channel Tx test method described in Annex C.
- (2) Reduce the base station output power by 2 dB, 5 dB and 13 dB, without changing the relative powers of the PCCPCH and the DPCHs, and repeat step (1) for each output power setting.

6.4.5.4.2.3 7,68 Mcps TDD option

- (1) Measure the PCCPCH code domain power in TS 0 and TS 8 by applying the global in-channel Tx test method described in Annex C.
- (2) Reduce the base station output power by 2 dB, 5 dB and 13 dB, without changing the relative powers of the PCCPCH and the DPCHs, and repeat step (1) for each output power setting.

6.4.5.5 Test Requirements

NOTE: If the Test Requirement below differs from the Minimum Requirement, then the Test Tolerance applied for this test is non-zero. The Test Tolerance for this test is defined in subclause 5.11 and the explanation of how the Minimum Requirement has been relaxed by the Test Tolerance is given in Annex D.

The Primary CCPCH power, measured according to subclause 6.4.5.4.2, shall be within the limits defined in table 6.10

Table 6.10: Test Requirements for errors between Primary CCPCH power and the broadcast value

Output power in slot, dB	PCCPCH power tolerance
$PRAT - 3 < P_{out} \leq PRAT + 2$	+/- 3,3 dB
$PRAT - 6 < P_{out} \leq PRAT - 3$	+/- 4,3 dB
$PRAT - 13 < P_{out} \leq PRAT - 6$	+/- 5,8 dB

6.4.6 Differential accuracy of Primary CCPCH power

6.4.6.1 Definition and applicability

The differential accuracy of the Primary CCPCH power is the relative transmitted power accuracy of PCCPCH in consecutive frames when the nominal PCCPCH power is not changed.

The requirements in this subclause shall apply to both Wide Area BS and Local Area BS.

6.4.6.2 Minimum Requirements

The differential accuracy of PCCPCH power shall be within $\pm 0,5$ dB.

The normative reference for this requirement is TS 25.105 [1] subclause 6.4.6.

6.4.6.3 Test purpose

The power of the Primary CCPCH received by the UE, together with the information on the Primary CCPCH nominal transmit power signaled on the BCH, are used by the UE for path loss estimation and adjustment of its own transmit power. Therefore, a lack of accuracy of the Primary CCPCH power over time will result in unwanted fluctuations of the transmit power of the UE which may degrade system performance.

The test purpose is to verify that the differential accuracy of the Primary CCPCH power remains within its specified tolerances.

6.4.6.4 Method of test

6.4.6.4.1 Initial conditions

6.4.6.4.1.0 General test conditions

Test environment: normal; see subclause 5.9.1.

RF channels to be tested: B, M and T; see subclause 5.3.

6.4.6.4.1.1 3,84 Mcps TDD option

- 1) Connect the BS tester to the antenna connector of the BS under test. The BS tester must have the ability to analyze the output signal of the BS under test with respect to code domain power, by applying the global in-channel Tx test method described in Annex C.
- 2) Set the parameters of the BS transmitted signal according to table 6.10A.

Table 6.10A: Parameters of the BS transmitted signal for testing of differential accuracy of the Primary CCPCH power

Parameter	Value/description
TDD Duty Cycle	TS i ; $i = 0, 1, 2, \dots, 14$: transmit, if i is even; receive, if i is odd.
Time slots carrying PCCPCH	TS 0 and TS 8
Number of additional DPCH in TS 0 and TS 8	3
BS output power setting	PRAT
Relative power of PCCPCH	$\frac{1}{4}$ of BS output power
Relative power of each DPCH in TS 0 and TS 8	$\frac{1}{4}$ of BS output power
Data content of DPCH	real life (sufficient irregular)

6.4.6.4.1.2 1,28 Mcps TDD option

- 1) Connect the BS tester to the antenna connector of the BS under test. The BS tester must have the ability to analyze the output signal of the BS under test with respect to code domain power, by applying the global in-channel Tx test method described in Annex C.
- 2) Set the parameters of the BS transmitted signal according to table 6.9A.

Table 6.10B: Parameters of the BS transmitted signal for testing of differential accuracy of the Primary CCPCH power for 1,28 Mcps TDD

Parameter	Value/description
TDD Duty Cycle	TS i ; $i = 0, 1, 2, \dots, 6$: transmit, if i is 0,4,5,6; receive, if i is 1,2,3.
Time slots carrying PCCPCH	TS 0
BS output power setting	PRAT
Relative power of PCCPCH	$\frac{1}{2}$ of BS output power
Data content of DPCH	real life (sufficient irregular)

6.4.6.4.1.3 7,68 Mcps TDD option

- 1) Connect the BS tester to the antenna connector of the BS under test. The BS tester must have the ability to analyze the output signal of the BS under test with respect to code domain power, by applying the global in-channel Tx test method described in Annex C.
- 2) Set the parameters of the BS transmitted signal according to table 6.10C.

Table 6.10C: Parameters of the BS transmitted signal for testing of differential accuracy of the Primary CCPCH power

Parameter	Value/description
TDD Duty Cycle	TS i ; $i = 0, 1, 2, \dots, 14$: transmit, if i is even; receive, if i is odd.
Time slots carrying PCCPCH	TS 0 and TS 8
Number of additional DPCH in TS 0 and TS 8	3
BS output power setting	PRAT
Relative power of PCCPCH	$\frac{1}{4}$ of BS output power
Relative power of each DPCH in TS 0 and TS 8	$\frac{1}{4}$ of BS output power
Data content of DPCH	real life (sufficient irregular)

6.4.6.4.2 Procedure

6.4.6.4.2.1 3,84 Mcps TDD option

- 1) Measure the PCCPCH code domain power in TS 0 and TS 8 of consecutive frames by applying the global in-channel Tx test method described in Annex C.
- 2) Calculate the differential accuracy of the Primary CCPCH power by taking the the difference between the PCCPCH power measurement results of consecutive frames.

6.4.6.4.2.2 1,28 Mcps TDD option

- 1) Measure the PCCPCH code domain power in TS 0 of consecutive frames by applying the global in-channel Tx test method described in Annex C.
- 2) Calculate the differential accuracy of the Primary CCPCH power by taking the the difference between the PCCPCH power measurement results of consecutive frames.

6.4.6.4.2.3 7,68 Mcps TDD option

- 1) Measure the PCCPCH code domain power in TS 0 and TS 8 of consecutive frames by applying the global in-channel Tx test method described in Annex C.
- 2) Calculate the differential accuracy of the Primary CCPCH power by taking the the difference between the PCCPCH power measurement results of consecutive frames.

6.4.6.5 Test Requirements

NOTE: If the Test Requirement below differs from the Minimum Requirement, then the Test Tolerance applied for this test is non-zero. The Test Tolerance for this test is defined in subclause 5.1.1 and the explanation of how the Minimum Requirement has been relaxed by the Test Tolerance is given in Annex D.

The differential accuracy of the Primary CCPCH power, measured according to subclause 6.4.6.4.2, shall be within $\pm 0,6$ dB.

6.5 Transmit ON/OFF power

6.5.1 Transmit OFF power

6.5.1.1 Definition and applicability

The transmit OFF power is defined as the RRC filtered mean power measured over one chip when the transmitter is off. The transmit OFF power state is when the BS does not transmit.

The requirements in this subclause shall apply to both Wide Area BS and Local Area BS.

6.5.1.2 Minimum Requirements

6.5.1.2.1 3,84 Mcps TDD option

The transmit OFF power shall be less than -79 dBm.

6.5.1.2.2 1,28 Mcps TDD option

The transmit OFF power shall be less than -82 dBm.

The normative reference for this requirement is TS 25.105 [1] subclause 6.5.1.

6.5.1.2.3 7,68 Mcps TDD option

The transmit OFF power shall be less than -76 dBm.

6.5.1.3 Test purpose

This test verifies the ability of the BS to reduce its transmit OFF power to a value below the specified limit. This ability is needed to minimize the interference for other users receiving on the same frequency.

6.5.1.4 Method of test

6.5.1.4.1 Initial conditions

The conformance testing of transmit OFF power is included in the conformance testing of transmit ON/OFF time mask; therefore, see subclause 6.5.2.4.1 for initial conditions.

6.5.1.4.2 Procedure

The conformance testing of transmit OFF power is included in the conformance testing of transmit ON/OFF time mask; therefore, see subclause 6.5.2.4.2 for procedure.

6.5.1.5 Test Requirements

The conformance testing of transmit OFF power is included in the conformance testing of transmit ON/OFF time mask; therefore, see subclause 6.5.2.5 for test requirements.

6.5.2 Transmit ON/OFF time mask

6.5.2.1 Definition and applicability

The transmit ON/OFF time mask defines the ramping time allowed for the BS between transmit OFF power and transmit ON power.

The requirements in this subclause shall apply to both Wide Area BS and Local Area BS.

6.5.2.2 Minimum Requirements

6.5.2.2.1 3,84 Mcps TDD option

The transmit power level versus time should meet the mask specified in figure 6.1.

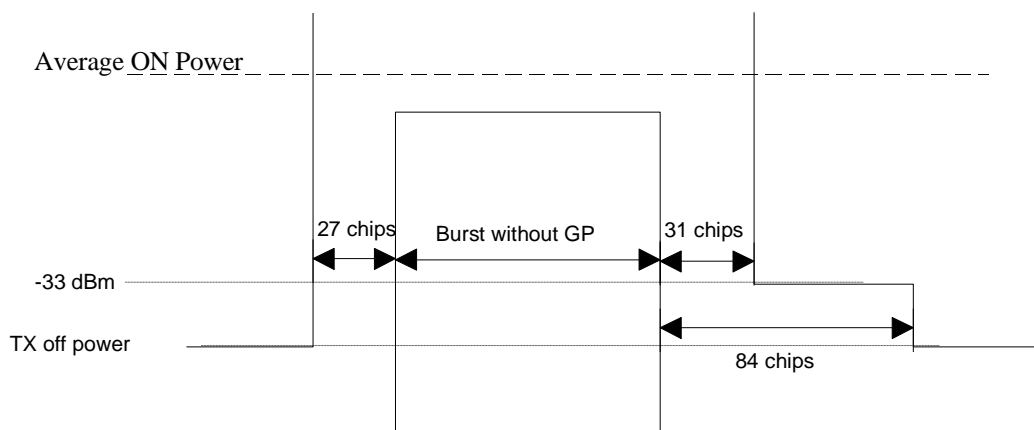

Figure 6.1: Transmit ON/OFF template

6.5.2.2.2 1,28 Mcps TDD option

The transmit power level versus time should meet the mask specified in figure 6.1A.

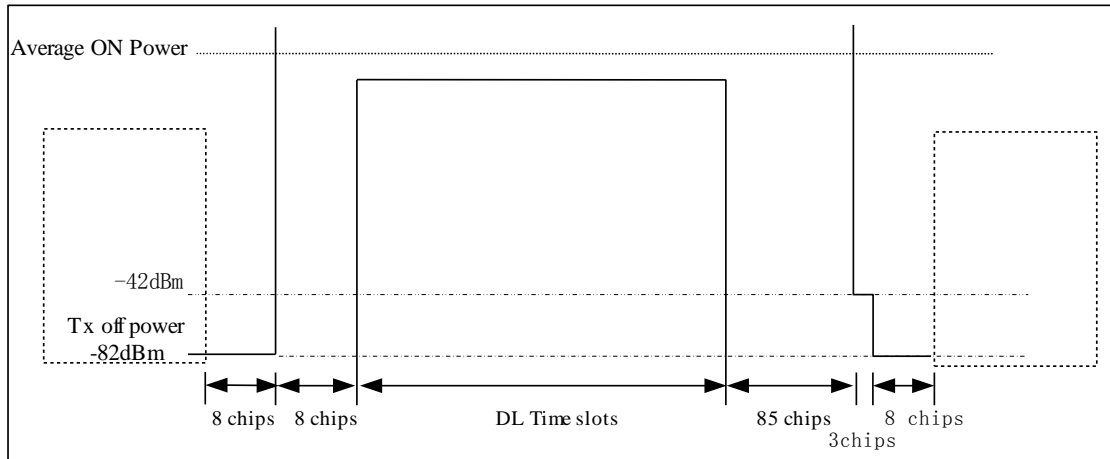

Figure 6.1A: Transmit ON/OFF template for 1,28 Mcps TDD option

The normative reference for this requirement is TS 25.105 [1] subclause 6.5.2.

6.5.2.2.3 7,68 Mcps TDD option

The transmit power level versus time should meet the mask specified in Figure 6.1B.

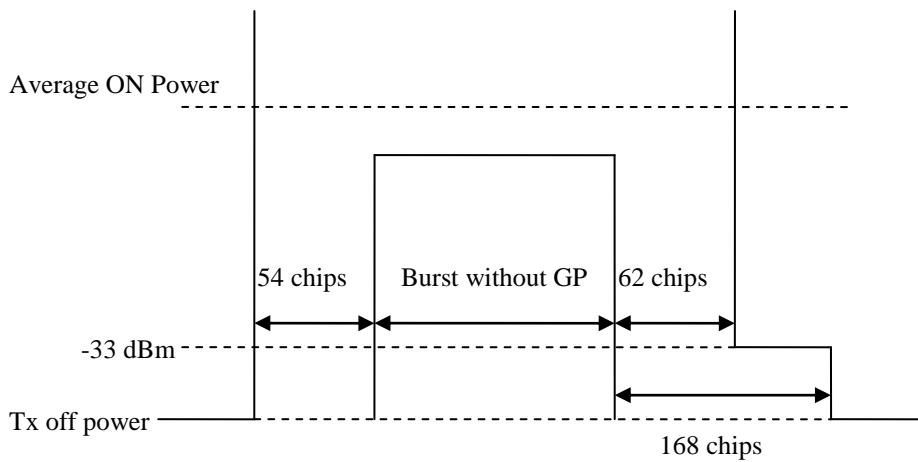

Figure 6.1B: Transmit ON/OFF template

6.5.2.3 Test purpose

This test verifies the ability of the BS to reduce its transmit power outside of the active part of the Tx time slot (burst without guard period) to values below specified limits. This ability is needed to minimize the interference for other users receiving on the same frequency.

6.5.2.4 Method of test

6.5.2.4.1 Initial conditions

6.5.2.4.1.0 General test conditions

Test environment: normal; see subclause 5.9.1.

RF channels to be tested: B, M and T; see subclause 5.3.

6.5.2.4.1.1 3,84 Mcps TDD option

- (1) Connect the power measuring equipment to the BS antenna connector.
- (2) Set the parameters of the transmitted signal according to table 6.11.

Table 6.11: Parameters of the transmitted signal for transmit ON/OFF time mask test

Parameter	Value/description
TDD Duty Cycle	TS i ; $i = 0, 1, 2, \dots, 14$: transmit, if i is even; receive, if i is odd.
Time slot carrying SCH	TS0
Time slots under test	TS i , i even and non zero
BS output power setting	PRAT
Number of DPCH in each time slot under test	9
Power of each DPCH	1/9 of Base Station output power
Data content of DPCH	Real life (sufficient irregular)

6.5.2.4.1.2 1,28 Mcps TDD option

- (1) Connect the power measuring equipment to the BS antenna connector.
- (2) Set the parameters of the transmitted signal according to table 6.11A.

Table 6.11A: Parameters of the transmitted signal for transmit ON/OFF time mask test for 1,28 Mcps TDD

Parameter	Value/description
TDD Duty Cycle	TS i ; $i = 0, 1, 2, 3, 4, 5, 6$: transmit, if i is 0,4,5,6; receive, if i is UpPCH,1,2,3.
Time slots under test	TS4, TS5 and TS6
BS output power setting	PRAT
Number of DPCH in each time slot under test	8
Power of each DPCH	1/8 of Base Station output power
Data content of DPCH	real life (sufficient irregular)

6.5.2.4.1.3 7,68 Mcps TDD option

- (1) Connect the power measuring equipment to the BS antenna connector.
- (2) Set the parameters of the transmitted signal according to table 6.11B.

Table 6.11B: Parameters of the transmitted signal for transmit ON/OFF time mask test

Parameter	Value/description
TDD Duty Cycle	TS i ; $i = 0, 1, 2, \dots, 14$: transmit, if i is even; receive, if i is odd.
Time slot carrying SCH	TS0
Time slots under test	TS i , i even and non zero
BS output power setting	PRAT
Number of DPCH in each time slot under test	9
Power of each DPCH	1/9 of Base Station output power
Data content of DPCH	Real life (sufficient irregular)

6.5.2.4.2 Procedure

6.5.2.4.2.1 3,84 Mcps TDD option

- (1) Measure the RRC filtered mean power of the BS output signal chipwise (i.e. averaged over time intervals of one chip duration) over the period starting 65 chips before the start of the odd time slots TS_i (receive time slots of the BS), and ending 27 chips before the next even time slot (transmit time slot of the BS) starts.

6.5.2.4.2.2 1,28 Mcps TDD option

- (1) Measure the RRC filtered mean power of the BS output signal chipwise (i.e. averaged over time intervals of one chip duration) over the transmit off power period starting 11 chips before the start of the receive time slot TS_i = UpPCH, and ending 8 chips before the next transmit time slot TS_{i+4} starts.

6.5.2.4.2.3 7,68 Mcps TDD option

- (1) Measure the RRC filtered mean power of the BS output signal chipwise (i.e. averaged over time intervals of one chip duration) over the period starting 130 chips before the start of the odd time slots TS_i (receive time slots of the BS), and ending 54 chips before the next even time slot (transmit time slot of the BS) starts.

6.5.2.5 Test Requirements

NOTE: If the Test Requirements below differ from the Minimum Requirements, then the Test Tolerance applied for this test is non-zero. The Test Tolerance for this test is defined in subclause 5.1.1 and the explanation of how the Minimum Requirement has been relaxed by the Test Tolerance is given in Annex D.

6.5.2.5.1 3,84 Mcps TDD option

Each value of the power measured according to subclause 6.5.2.4.2.1 shall be below - 32,3 dBm in the period from 32 chips to 84 chips after the burst and below - 77 dBm in the period where the Tx OFF power specification is applicable.

6.5.2.5.2 1,28 Mcps TDD option

Each value of the power measured according to subclause 6.5.2.4.2.2 shall be below - 41,3 dBm in the period from 85 chips to 88 chips after the burst and below - 80 dBm in the period where the Tx OFF power specification is applicable.

6.5.2.5.3 7,68 Mcps TDD option

Each value of the power measured according to subclause 6.5.2.4.2.3 shall be below - 32,3 dBm in the period from 64 chips to 168 chips after the burst and below - 74 dBm in the period where the Tx OFF power specification is applicable.

6.6 Output RF spectrum emissions

6.6.1 Occupied bandwidth

6.6.1.1 Definition and applicability

Occupied bandwidth is a measure of the bandwidth containing 99% of the total integrated power for transmitted spectrum and is centered on the assigned channel frequency.

The requirements in this subclause shall apply to both Wide Area BS and Local Area BS.

6.6.1.2 Minimum Requirements

6.6.1.2.1 3,84 Mcps TDD option

The occupied bandwidth shall be less than 5 MHz based on a chip rate of 3,84 Mcps.

The normative reference for this requirement is TS 25.105 [1] subclause 6.6.1.1.

6.6.1.2.2 1,28 Mcps TDD option

The occupied bandwidth shall be less than 1,6 MHz based on a chip rate of 1,28 Mcps.

The reference for this requirement is TS 25.105 [1] subclause 6.6.1.2.

6.6.1.2.3 7,68 Mcps TDD option

The occupied bandwidth shall be less than 10 MHz based on a chip rate of 7,68 Mcps.

The reference for this requirement is TS 25.105 [1] subclause 6.6.1.3.

6.6.1.3 Test purpose

The occupied bandwidth, defined in the Radio Regulations of the International Telecommunication Union ITU, is a useful concept for specifying the spectral properties of a given emission in the simplest possible manner; see also Recommendation ITU-R SM.328 [7]. The test purpose is to verify that the emission of the BS does not occupy an excessive bandwidth for the service to be provided and is, therefore, not likely to create interference to other users of the spectrum beyond undue limits.

6.6.1.4 Method of test

6.6.1.4.1 Initial conditions

6.6.1.4.1.0 General test conditions

Test environment: normal; see subclause 5.9.1.

RF channels to be tested: B, M and T; see subclause 5.3.

6.6.1.4.1.1 3,84 Mcps TDD option

- (1) Connect the measuring equipment to the antenna connector of the BS under test.
- (2) Set the parameters of the BS transmitted signal according to table 6.12. For MBSFN IMB operation the set of parameters for the transmitted signals is according to IMB test model 1 in subclause 6.1.1.1.

Table 6.12: Parameters of the BS transmitted signal for occupied bandwidth testing

Parameter	Value/description
TDD Duty Cycle	TS i ; $i = 0, 1, 2, \dots, 14$: transmit, if i is even; receive, if i is odd.
Time slot carrying SCH	TS0
Time slots under test	TS i , i even and non zero
BS output power setting	PRAT
Number of DPCH in each time slot under test	9
Power of each DPCH	1/9 of Base Station output power
Data content of DPCH	Real life (sufficient irregular)

6.6.1.4.1.2 1,28 Mcps TDD option

- (1) Connect the measuring equipment to the antenna connector of the BS under test.
- (2) Set the parameters of the BS transmitted signal according to table 6.12A.

Table 6.12A: Parameters of the BS transmitted signal for occupied bandwidth testing for 1,28 Mcps TDD

Parameter	Value/description
TDD Duty Cycle	TS i ; $i = 0, 1, 2, 3, 4, 5, 6$: transmit, if i is 0,4,5,6; receive, if i is 1,2,3.
Time slots under test	TS4, TS5 and TS6
BS output power setting	PRAT
Number of DPCH in each time slot under test	8
Power of each DPCH	1/8 of Base Station output power
Data content of DPCH	real life (sufficient irregular)

6.6.1.4.1.3 7,68 Mcps TDD option

- (1) Connect the measuring equipment to the antenna connector of the BS under test.
- (2) Set the parameters of the BS transmitted signal according to table 6.12B.

Table 6.12B: Parameters of the BS transmitted signal for occupied bandwidth testing

Parameter	Value/description
TDD Duty Cycle	TS i ; $i = 0, 1, 2, \dots, 14$: transmit, if i is even; receive, if i is odd.
Time slot carrying SCH	TS0
Time slots under test	TS i , i even and non zero
BS output power setting	PRAT
Number of DPCH in each time slot under test	9
Power of each DPCH	1/9 of Base Station output power
Data content of DPCH	Real life (sufficient irregular)

6.6.1.4.2 Procedure

6.6.1.4.2.1 3,84 Mcps TDD option

- (1) Measure the power of the transmitted signal with a measurement filter of bandwidth 30 kHz. The characteristic of the filter shall be approximately Gaussian (typical spectrum analyzer filter). The centre frequency of the filter shall be stepped in contiguous 30 kHz steps from a minimum frequency, which shall be $(7,5 - 0,015)$ MHz below the assigned channel frequency of the transmitted signal, up to a maximum frequency, which shall be $(7,5 + 0,015)$ MHz above the assigned channel frequency of the transmitted signal. The time duration of each step shall be sufficiently long to capture one active time slot. The measured power shall be recorded for each step.
- (2) Determine the total output power by accumulating the recorded power measurement results of all steps.
- (3) Sum up the recorded power measurement results, starting from the step at the minimum frequency defined in (1) up to the step at a lower limit frequency by which this sum is equal to or greater than 0.5 % of the total output power determined in (2). This limit frequency is recorded as "Lower Frequency".
- (4) Sum up the recorded power measurement results, starting from the step at the maximum frequency defined in (1) down to the step at an upper limit frequency by which this sum is equal to or greater than 0.5 % of the total output power determined in (2). This limit frequency is recorded as "Upper Frequency".
- (5) Calculate the occupied bandwidth as the difference between the "Upper Frequency" obtained in (3) and the "Lower Frequency" obtained in (4).

6.6.1.4.2.2 1,28 Mcps TDD option

- (1) Measure the power of the transmitted signal with a measurement filter of bandwidth 30 kHz. The characteristic of the filter shall be approximately Gaussian (typical spectrum analyser filter). The centre frequency of the filter

shall be stepped in contiguous 30 kHz steps from a minimum frequency, which shall be (2,4 - 0,015) MHz below the assigned channel frequency of the transmitted signal, up to a maximum frequency, which shall be (2,4 - 0,015) MHz above the assigned channel frequency of the transmitted signal. The time duration of each step shall be sufficiently long to capture one active time slot. The measured power shall be recorded for each step.

- (2) Determine the total output power by accumulating the recorded power measurement results of all steps.
- (3) Sum up the recorded power measurement results, starting from the step at the minimum frequency defined in (1) up to the step at a lower limit frequency by which this sum is equal to or greater than 0,5 % of the total output power determined in (2). This limit frequency is recorded as "Lower Frequency".
- (4) Sum up the recorded power measurement results, starting from the step at the maximum frequency defined in (1) down to the step at an upper limit frequency by which this sum is equal to or greater than 0,5 % of the total output power determined in (2). This limit frequency is recorded as "Upper Frequency".
- (5) Calculate the occupied bandwidth as the difference between the "Upper Frequency" obtained in (3) and the "Lower Frequency" obtained in (4).

6.6.1.4.2.3 7,68 Mcps TDD option

- (1) Measure the power of the transmitted signal with a measurement filter of bandwidth 30 kHz. The characteristic of the filter shall be approximately Gaussian (typical spectrum analyzer filter). The centre frequency of the filter shall be stepped in contiguous 30 kHz steps from a minimum frequency, which shall be (15 - 0,015) MHz below the assigned channel frequency of the transmitted signal, up to a maximum frequency, which shall be (15 - 0,015) MHz above the assigned channel frequency of the transmitted signal. The time duration of each step shall be sufficiently long to capture one active time slot. The measured power shall be recorded for each step.
- (2) Determine the total output power by accumulating the recorded power measurement results of all steps.
- (3) Sum up the recorded power measurement results, starting from the step at the minimum frequency defined in (1) up to the step at a lower limit frequency by which this sum is equal to or greater than 0.5 % of the total output power determined in (2). This limit frequency is recorded as "Lower Frequency".
- (4) Sum up the recorded power measurement results, starting from the step at the maximum frequency defined in (1) down to the step at an upper limit frequency by which this sum is equal to or greater than 0.5 % of the total output power determined in (2). This limit frequency is recorded as "Upper Frequency".
- (5) Calculate the occupied bandwidth as the difference between the "Upper Frequency" obtained in (3) and the "Lower Frequency" obtained in (4).

6.6.1.5 Test Requirements

NOTE: If the Test Requirement below differ from the Minimum Requirements, then the Test Tolerance applied for this test is non-zero. The Test Tolerance for this test is defined in subclause 5.1.1 and the explanation of how the Minimum Requirement has been relaxed by the Test Tolerance is given in Annex D.

6.6.1.5.1 3,84 Mcps TDD option

The occupied bandwidth calculated in step (5) of subclause 6.6.1.4.2.1 shall be less than 5 MHz.

6.6.1.5.2 1,28 Mcps TDD option

The occupied bandwidth calculated in step (5) of subclause 6.6.1.4.2.2 shall be less than 1,6 MHz.

6.6.1.5.3 7,68 Mcps TDD option

The occupied bandwidth calculated in step (5) of subclause 6.6.1.4.2.3 shall be less than 10 MHz.

6.6.2 Out of band emission

Out of band emissions are unwanted emissions immediately outside the channel bandwidth resulting from the modulation process and non-linearity in the transmitter but excluding spurious emissions. This out of band emission requirement is specified both in terms of a spectrum emission mask and adjacent channel power ratio for the transmitter.

6.6.2.1 Spectrum emission mask

6.6.2.1.1 Definition and applicability

6.6.2.1.1.1 3,84 Mcps TDD option

The spectrum emission mask specifies the limit of the transmitter out of band emissions at frequency offsets from the assigned channel frequency of the wanted signal between 2,5 MHz and 12,5 MHz.

The mask defined in subclause 6.6.2.1.2.1 below may be mandatory in certain regions. In other regions this mask may not be applied.

For regions in which the mask is mandatory, the requirements shall apply to both Wide Area BS and Local Area BS.

6.6.2.1.1.2 1,28 Mcps TDD option

The spectrum emission mask specifies the limit of the transmitter out of band emissions at frequency offsets from the assigned channel frequency of the wanted signal between 0,8 MHz and 4 MHz.

The mask defined in subclause 6.6.2.1.2.2 below may be mandatory in certain regions. In other regions this mask may not be applied.

For regions in which the mask is mandatory, the requirements shall apply to both Wide Area BS and Local Area BS.

6.6.2.1.1.3 7,68 Mcps TDD option

The spectrum emission mask specifies the limit of the transmitter out of band emissions at frequency offsets from the assigned channel frequency of the wanted signal between 5 MHz and 25 MHz.

The mask defined in subclause 6.6.2.1.2.3 below may be mandatory in certain regions. In other regions this mask may not be applied.

For regions in which the mask is mandatory, the requirements shall apply to both Wide Area BS and Local Area BS.

6.6.2.1.2 Minimum Requirements

6.6.2.1.2.1 3,84 Mcps TDD option

For regions where this subclause applies, the requirement shall be met by a base station transmitting on a single RF carrier configured in accordance with the manufacturer's specification. Emissions shall not exceed the maximum level specified in tables 6.13 to 6.16 in the frequency range of f_{offset} from 2,515 MHz to $f_{\text{offset}_{\text{max}}}$ from the carrier frequency, where:

- f_{offset} is the separation between the carrier frequency and the centre of the measurement filter
- $f_{\text{offset}_{\text{max}}}$ is either 12,5 MHz or the offset to the UMTS Tx band edge as defined in subclause 4.2, whichever is the greater.

Table 6.13: Spectrum emission mask values, BS maximum output power $P \geq 43$ dBm

Frequency offset of measurement filter centre frequency, f_{offset}	Maximum level	Measurement bandwidth
$2,515 \text{ MHz} \leq f_{\text{offset}} < 2,715 \text{ MHz}$	-14 dBm	30 kHz
$2,715 \text{ MHz} \leq f_{\text{offset}} < 3,515 \text{ MHz}$	$-14\text{dBm} - 15 \cdot \left(\frac{f_{\text{offset}}}{\text{MHz}} - 2,715 \right) \text{dB}$	30 kHz
$3,515 \text{ MHz} \leq f_{\text{offset}} < 4,0 \text{ MHz}$	-26 dBm	30 kHz
$4,0 \text{ MHz} \leq f_{\text{offset}} < 8,0 \text{ MHz}$	-13 dBm	1 MHz
$8,0 \text{ MHz} \leq f_{\text{offset}} < f_{\text{offset}_{\text{max}}}$	-13 dBm	1 MHz

Table 6.14: Spectrum emission mask values, BS maximum output power $39 \leq P < 43$ dBm

Frequency offset of measurement filter centre frequency, f_{offset}	Maximum level	Measurement bandwidth
$2,515 \text{ MHz} \leq f_{\text{offset}} < 2,715 \text{ MHz}$	-14 dBm	30 kHz
$2,715 \text{ MHz} \leq f_{\text{offset}} < 3,515 \text{ MHz}$	$-14\text{dBm} - 15 \cdot \left(\frac{f_{\text{offset}}}{\text{MHz}} - 2,715 \right) \text{dB}$	30 kHz
$3,515 \text{ MHz} \leq f_{\text{offset}} < 4,0 \text{ MHz}$	-26 dBm	30 kHz
$4,0 \text{ MHz} \leq f_{\text{offset}} < 8,0 \text{ MHz}$	-13 dBm	1 MHz
$8,0 \text{ MHz} \leq f_{\text{offset}} < f_{\text{offset}_{\text{max}}}$	$P - 56 \text{ dB}$	1 MHz

Table 6.15: Spectrum emission mask values, BS maximum output power $31 \leq P < 39$ dBm

Frequency offset of measurement filter centre frequency, f_{offset}	Maximum level	Measurement bandwidth
$2,515 \text{ MHz} \leq f_{\text{offset}} < 2,715 \text{ MHz}$	$P - 53 \text{ dB}$	30 kHz
$2,715 \text{ MHz} \leq f_{\text{offset}} < 3,515 \text{ MHz}$	$P - 53\text{dB} - 15 \cdot \left(\frac{f_{\text{offset}}}{\text{MHz}} - 2,715 \right) \text{dB}$	30 kHz
$3,515 \text{ MHz} \leq f_{\text{offset}} < 4,0 \text{ MHz}$	$P - 65 \text{ dB}$	30 kHz
$4,0 \text{ MHz} \leq f_{\text{offset}} < 8,0 \text{ MHz}$	$P - 52 \text{ dB}$	1 MHz
$8,0 \text{ MHz} \leq f_{\text{offset}} < f_{\text{offset}_{\text{max}}}$	$P - 56 \text{ dB}$	1 MHz

Table 6.16: Spectrum emission mask values, BS maximum output power $P < 31$ dBm

Frequency offset of measurement filter centre frequency, f_{offset}	Maximum level	Measurement bandwidth
$2,515 \text{ MHz} \leq f_{\text{offset}} < 2,715 \text{ MHz}$	-22 dBm	30 kHz
$2,715 \text{ MHz} \leq f_{\text{offset}} < 3,515 \text{ MHz}$	$-22\text{dBm} - 15 \cdot \left(\frac{f_{\text{offset}}}{\text{MHz}} - 2,715 \right) \text{dB}$	30 kHz
$3,515 \text{ MHz} \leq f_{\text{offset}} < 4,0 \text{ MHz}$	-34 dBm	30 kHz
$4,0 \text{ MHz} \leq f_{\text{offset}} < 8,0 \text{ MHz}$	-21 dBm	1 MHz
$8,0 \text{ MHz} \leq f_{\text{offset}} < f_{\text{offset}_{\text{max}}}$	-25 dBm	1 MHz

The normative reference for this requirement is TS 25.105 [1] subclause 6.6.2.1.1

6.6.2.1.2.2 1,28 Mcps TDD option

For regions where this subclause applies, the requirement shall be met by a base station transmitting on a single RF carrier configured in accordance with the manufacturer's specification. Emissions shall not exceed the maximum level specified in tables 6.13A to 16A in the frequency range of f_{offset} from 0.815 MHz to $f_{\text{offset}_{\text{max}}}$ from the carrier frequency, where:

- f_{offset} is the separation between the carrier frequency and the centre of the measurement filter
- $f_{\text{offset}_{\text{max}}}$ is either 4 MHz or the offset to the UMTS Tx band edge as defined in subclause 4.2, whichever is the greater.

Table 6.13A: Spectrum emission mask values, BS maximum output power $P \geq 34$ dBm for 1,28 Mcps TDD

Frequency offset of measurement filter centre frequency, f_{offset}	Maximum level	Measurement bandwidth
$0.815\text{MHz} \leq f_{\text{offset}} < 1.015\text{MHz}$	-20 dBm	30 kHz
$1.015\text{MHz} \leq f_{\text{offset}} < 1.815\text{MHz}$	$-20\text{dBm} - 10 \cdot \left(\frac{f_{\text{offset}}}{\text{MHz}} - 1,015 \right) \text{dB}$	30 kHz
$1.815\text{MHz} \leq f_{\text{offset}} < 2.3\text{MHz}$	-28 dBm	30 kHz
$2.3\text{MHz} \leq f_{\text{offset}} < f_{\text{offset}_{\text{max}}}$	-13 dBm	1 MHz

Table 6.14A: Spectrum emission mask values, BS maximum output power $26 \leq P < 34$ dBm for 1,28 Mcps TDD

Frequency offset of measurement filter centre frequency, f_{offset}	Maximum level	Measurement bandwidth
$0.815\text{MHz} \leq f_{\text{offset}} < 1.015\text{MHz}$	$P - 54$ dB	30 kHz
$1.015\text{MHz} \leq f_{\text{offset}} < 1.815\text{MHz}$	$P - 54\text{dB} - 10 \cdot \left(\frac{f_{\text{offset}}}{\text{MHz}} - 1,015 \right) \text{dB}$	30 kHz
$1.815\text{MHz} \leq f_{\text{offset}} < 2.3\text{MHz}$	$P - 62$ dB	30 kHz
$2.3\text{MHz} \leq f_{\text{offset}} < f_{\text{offset}_{\text{max}}}$	$P - 47$ dB	1 MHz

Table 6.16A: Spectrum emission mask values, BS maximum output power $P < 26$ dBm for 1,28 Mcps TDD

Frequency offset of measurement filter centre frequency, f_{offset}	Maximum level	Measurement bandwidth
$0.815\text{MHz} \leq f_{\text{offset}} < 1.015\text{MHz}$	-28 dBm	30 kHz
$1.015\text{MHz} \leq f_{\text{offset}} < 1.815\text{MHz}$	$-28\text{dBm} - 10 \cdot \left(\frac{f_{\text{offset}}}{\text{MHz}} - 1,015 \right) \text{dB}$	30 kHz
$1.815\text{MHz} \leq f_{\text{offset}} < 2.3\text{MHz}$	-36 dBm	30 kHz
$2.3\text{MHz} \leq f_{\text{offset}} < f_{\text{offset}_{\text{max}}}$	-21 dBm	1 MHz

The normative reference for this requirement is TS 25.105 [1] subclause 6.6.2.1.2.

6.6.2.1.2.3 7,68 Mcps TDD option

For regions where this subclause applies, the requirement shall be met by a base station transmitting on a single RF carrier configured in accordance with the manufacturer's specification. Emissions shall not exceed the maximum level specified in tables 6.13B to 6.16B in the frequency range of f_{offset} from 5,015 MHz to $f_{\text{offset}_{\text{max}}}$ from the carrier frequency, where:

- f_{offset} is the separation between the carrier frequency and the centre of the measurement filter
- $f_{\text{offset}_{\text{max}}}$ is either 25 MHz or the offset to the UMTS Tx band edge as defined in subclause 4.2, whichever is the greater.

Table 6.13B: Spectrum emission mask values, BS maximum output power $P \geq 43$ dBm

Frequency offset of measurement filter centre frequency, f_{offset}	Maximum level	Measurement bandwidth
$5.015\text{MHz} \leq f_{\text{offset}} < 5.215\text{MHz}$	-17 dBm	30 kHz
$5.215\text{MHz} \leq f_{\text{offset}} < 6.015\text{MHz}$	$-17\text{dBm} - 15 \cdot \left(\frac{f_{\text{offset}}}{\text{MHz}} - 5.215 \right) \text{dB}$	30 kHz
$6.015\text{MHz} \leq f_{\text{offset}} < 6.5\text{MHz}$	-29 dBm	30 kHz
$6.5\text{MHz} \leq f_{\text{offset}} < f_{\text{offset}_{\text{max}}}$	-16 dBm	1 MHz
$5.015\text{MHz} \leq f_{\text{offset}} < 5.215\text{MHz}$	-17 dBm	30 kHz

Table 6.14B: Spectrum emission mask values, BS maximum output power $39 \leq P < 43$ dBm

Frequency offset of measurement filter centre frequency, f_{offset}	Maximum level	Measurement bandwidth
$5.015\text{MHz} \leq f_{\text{offset}} < 5.215\text{MHz}$	-17 dBm	30 kHz
$5.215\text{MHz} \leq f_{\text{offset}} < 6.015\text{MHz}$	$-17\text{dBm} - 15 \cdot \left(\frac{f_{\text{offset}}}{\text{MHz}} - 5.215 \right) \text{dB}$	30 kHz
$6.015\text{MHz} \leq f_{\text{offset}} < 6.5\text{MHz}$	-29 dBm	30 kHz
$6.5\text{MHz} \leq f_{\text{offset}} < 15.5\text{MHz}$	-16 dBm	1 MHz
$15.5\text{MHz} \leq f_{\text{offset}} < f_{\text{offset}_{\text{max}}}$	$P - 59$ dB	1 MHz

Table 6.15B: Spectrum emission mask values, BS maximum output power $31 \leq P < 39$ dBm

Frequency offset of measurement filter centre frequency, f_{offset}	Maximum level	Measurement bandwidth
$5.015\text{MHz} \leq f_{\text{offset}} < 5.215\text{MHz}$	$P - 56$ dB	30 kHz
$5.215\text{MHz} \leq f_{\text{offset}} < 6.015\text{MHz}$	$P - 56\text{dB} - 15 \cdot \left(\frac{f_{\text{offset}}}{\text{MHz}} - 5.215 \right) \text{dB}$	30 kHz
$6.015\text{MHz} \leq f_{\text{offset}} < 6.5\text{MHz}$	$P - 68$ dB	30 kHz
$6.5\text{MHz} \leq f_{\text{offset}} < 15.5\text{MHz}$	$P - 55$ dB	1 MHz
$15.5\text{MHz} \leq f_{\text{offset}} < f_{\text{offset}_{\text{max}}}$	$P - 59$ dB	1 MHz

Table 6.16B: Spectrum emission mask values, BS maximum output power $P < 31$ dBm

Frequency offset of measurement filter centre frequency, f_{offset}	Maximum level	Measurement bandwidth
$5.015\text{MHz} \leq f_{\text{offset}} < 5.215\text{MHz}$	-25 dBm	30 kHz
$5.215\text{MHz} \leq f_{\text{offset}} < 6.015\text{MHz}$	$-25\text{dBm} - 15 \cdot \left(\frac{f_{\text{offset}}}{\text{MHz}} - 5.215 \right) \text{dB}$	30 kHz
$6.015\text{MHz} \leq f_{\text{offset}} < 6.5\text{MHz}$	-37 dBm	30 kHz
$6.5\text{MHz} \leq f_{\text{offset}} < 15.5\text{MHz}$	-24 dBm	1 MHz
$15.5\text{MHz} \leq f_{\text{offset}} < f_{\text{offset}_{\text{max}}}$	-28 dBm	1 MHz

The normative reference for this requirement is TS 25.105 [1] subclause 6.6.2.1.3.

6.6.2.1.3 Test purpose

The test purpose is to verify that the BS out of band emissions do not result in undue interference to any other system (wideband, narrowband) operating at frequencies close to the assigned channel bandwidth of the wanted signal.

This test is independent of the characteristics of possible victim systems and, therefore, complements the tests on occupied bandwidth in 6.6.1 (verifying the spectral concentration of the BS Tx emissions) and on ACLR in 6.6.2.2 (simulating the perception of other UTRA receivers).

6.6.2.1.4 Method of test

6.6.2.1.4.1 Initial conditions

For 3,84 Mcps BS supporting 16QAM, the spectrum emission mask requirements shall be tested with the general test set up specified in section 6.6.2.1.4.1.1 and also with the special test set up for 16QAM capable BS specified in section 6.6.2.1.4.1.4.

For 1,28 Mcps BS supporting 16QAM, the spectrum emission mask requirements shall be tested with the general test set up specified in section 6.6.2.1.4.1.2 and also with the special test set up for 16QAM capable BS specified in section 6.6.2.1.4.1.3.

6.6.2.1.4.1.0 General test conditions

Test environment: normal; see subclause 5.9.1.

RF channels to be tested: B, M and T; see subclause 5.3.

6.6.2.1.4.1.1 3,84 Mcps TDD option - General test set up

- (1) Connect the measuring equipment to the antenna connector of the BS under test.
- (2) Set the parameters of the BS transmitted signal according to table 6.17. For MBSFN IMB operation the set of parameters for the transmitted signals is according to IMB test model 1 in subclause 6.1.1.1.

Table 6.17: Parameters of the BS transmitted signal for spectrum emission mask testing

Parameter	Value/description
TDD Duty Cycle	TS i ; $i = 0, 1, 2, \dots, 14$: transmit, if i is even; receive, if i is odd.
Time slot carrying SCH	TS0
Time slots under test	TS i , i even and non zero
BS output power setting	PRAT
Number of DPCH in each time slot under test	9
Power of each DPCH	1/9 of Base Station output power
Data content of DPCH	real life (sufficient irregular)

6.6.2.1.4.1.2 1,28 Mcps TDD option - General test set up

- (1) Connect the measuring equipment to the antenna connector of the BS under test.
- (2) Set the parameters of the BS transmitted signal according to table 6.17A.

Table 6.17A: Parameters of the BS transmitted signal for spectrum emission mask testing for 1,28 Mcps TDD

Parameter	Value/description
TDD Duty Cycle	TS i ; $i = 0, 1, 2, 3, 4, 5, 6$: transmit, if i is 0,4,5,6; receive, if i is 1,2,3.
Time slots under test	TS4, TS5 and TS6
BS output power setting	PRAT
Number of DPCH in each time slot under test	8
Power of each DPCH	1/8 of Base Station output power
Data content of DPCH	real life (sufficient irregular)

6.6.2.1.4.1.3 1,28 Mcps TDD option - Special test set up for 16QAM capable BS

This test set up only applies for 16QAM capable BS.

- (1) Connect the measuring equipment to the antenna connector of the BS under test.
- (2) Set the parameters of the BS transmitted signal according to table 6.17B.

Table 6.17B: Parameters of the BS transmitted signal for spectrum emission mask testing for 1,28 Mcps TDD - 16QAM capable BS

Parameter	Value/description
TDD Duty Cycle	TS i ; $i = 0, 1, 2, 3, 4, 5, 6$: transmit, if i is 0,4,5,6; receive, if i is 1,2,3.
Time slots under test	TS4, TS5 and TS6
BS output power setting	PRAT
HS-PDSCH modulation	16QAM
Number of HS-PDSCH in each time slot under test	8
Power of each HS-PDSCH	1/8 of Base Station output power
Data content of HS-PDSCH	real life (sufficient irregular)
Spreading factor	16

6.6.2.1.4.1.4 3,84 Mcps TDD option - Special test set up for 16QAM capable BS

This test set up only applies for 16QAM capable BS.

- (1) Connect the measuring equipment to the antenna connector of the BS under test.
- (2) Set the parameters of the BS transmitted signal according to table 6.17C. For MBSFN IMB operation the set of parameters for the transmitted signals is according to IMB test model 2 in subclause 6.1.1.2.

Table 6.17C: Parameters of the BS transmitted signal for spectrum emission mask testing - 16QAM capable BS

Parameter	Value/description
TDD Duty Cycle	TS i ; $i = 0, 1, 2, \dots, 14$: transmit, if i is even; receive, if i is odd.
Time slot carrying SCH	TS0
Time slots under test	TS i , i even and non zero
BS output power setting	PRAT
HS-PDSCH modulation	16QAM
Number of HS-PDSCH in each time slot under test	9
Power of each HS-PDSCH	1/9 of Base Station output power
Data content of HS-PDSCH	real life (sufficient irregular)
Spreading factor	16

6.6.2.1.4.1.5 7,68 Mcps TDD option - General test set up

- (1) Connect the measuring equipment to the antenna connector of the BS under test.
- (2) Set the parameters of the BS transmitted signal according to table 6.17D.

Table 6.17D: Parameters of the BS transmitted signal for spectrum emission mask testing

Parameter	Value/description
TDD Duty Cycle	TS i ; $i = 0, 1, 2, \dots, 14$: transmit, if i is even; receive, if i is odd.
Time slot carrying SCH	TS0
Time slots under test	TS i , i even and non zero
BS output power setting	PRAT
Number of DPCH in each time slot under test	9
Power of each DPCH	1/9 of Base Station output power
Data content of DPCH	real life (sufficient irregular)

6.6.2.1.4.1.6 7,68 Mcps TDD option - Special test set up for 16QAM capable BS

This test set up only applies for 16QAM capable BS.

- (1) Connect the measuring equipment to the antenna connector of the BS under test.
- (2) Set the parameters of the BS transmitted signal according to table 6.17E.

Table 6.17E: Parameters of the BS transmitted signal for spectrum emission mask testing - 16QAM capable BS

Parameter	Value/description
TDD Duty Cycle	TS i ; $i = 0, 1, 2, \dots, 14$: transmit, if i is even; receive, if i is odd.
Time slot carrying SCH	TS0
Time slots under test	TS i , i even and non zero
BS output power setting	PRAT
HS-PDSCH modulation	16QAM
Number of HS-PDSCH in each time slot under test	9
Power of each HS-PDSCH	1/9 of Base Station output power
Data content of HS-PDSCH	real life (sufficient irregular)
Spreading factor	32

6.6.2.1.4.2 Procedure

6.6.2.1.4.2.1 3,84 Mcps TDD option

Measure the power of the BS spectrum emissions by applying measurement filters with bandwidths as specified in the relevant table in subclause 6.6.2.1.2.1. The characteristic of the filters shall be approximately Gaussian (typical spectrum analyzer filters). The centre frequency of the filter shall be stepped in contiguous steps over the ranges of frequency offsets f_{offset} as given in the tables. The step width shall be equal to the respective measurement bandwidth. The time duration of each step shall be sufficiently long to capture one active time slot.

For frequency offsets of the measurement filter centre frequency in the range $4,0 \text{ MHz} \leq f_{\text{offset}} < f_{\text{offset,max}}$, the measurement shall be performed by applying filters with measurement bandwidth of 50 kHz or less and integrating the measured results over the nominal measurement bandwidth 1 MHz specified in the tables in subclause 6.6.2.1.2.1.

6.6.2.1.4.2.2 1,28 Mcps TDD option

Measure the power of the BS spectrum emissions by applying measurement filters with bandwidths as specified in the relevant table in subclause 6.6.2.1.2.2. The characteristic of the filters shall be approximately Gaussian (typical spectrum analyzer filters). The centre frequency of the filter shall be stepped in contiguous steps over the ranges of frequency offsets f_{offset} as given in the tables. The step width shall be equal to the respective measurement bandwidth. The time duration of each step shall be sufficiently long to capture one active time slot.

The measurement shall be performed by applying filters with measurement bandwidth of 50 kHz or less and integrating the measured results over the nominal measurement bandwidth 1 MHz specified in the tables in subclause 6.6.2.1.2.2 when the measurement bandwidth is 1MHz.

6.6.2.1.4.2.3 1,28 Mcps TDD option - 16QAM capable BS

The same procedure specified in 6.6.2.1.4.2.2 applies to 1,28 Mcps TDD option BS supporting 16QAM.

6.6.2.1.4.2.4 3,84 Mcps TDD option - 16QAM capable BS

The same procedure specified in 6.6.2.1.4.2.1 applies to 3,84 Mcps TDD option BS supporting 16QAM.

6.6.2.1.4.2.5 7,68 Mcps TDD option

Measure the power of the BS spectrum emissions by applying measurement filters with bandwidths as specified in the relevant table in subclause 6.6.2.1.2.3. The characteristic of the filters shall be approximately Gaussian (typical spectrum analyzer filters). The centre frequency of the filter shall be stepped in contiguous steps over the ranges of frequency offsets f_{offset} as given in the tables. The step width shall be equal to the respective measurement bandwidth. The time duration of each step shall be sufficiently long to capture one active time slot.

For frequency offsets of the measurement filter centre frequency in the range $6,5 \text{ MHz} \leq f_{\text{offset}} < f_{\text{offset}_{\text{max}}}$, the measurement shall be performed by applying filters with measurement bandwidth of 50 kHz or less and integrating the measured results over the nominal measurement bandwidth 1 MHz specified in the tables in subclause 6.6.2.1.2.3.

6.6.2.1.4.2.6 7,68 Mcps TDD option - 16QAM capable BS

The same procedure specified in 6.6.2.1.4.2.5 applies to 7,68 Mcps TDD option BS supporting 16QAM.

6.6.2.1.5 Test Requirements

NOTE: If the Test Requirements below differ from the Minimum Requirements, then the Test Tolerance applied for this test is non-zero. The Test Tolerance for this test is defined in subclause 5.11 and the explanation of how the Minimum Requirement has been relaxed by the Test Tolerance is given in Annex D.

6.6.2.1.5.1 3,84 Mcps TDD option

The spectrum emissions measured according to subclause 6.6.2.1.4.2.1 shall not exceed the maximum level specified in tables 6.18 to 6.21 for the appropriate BS maximum output power

Table 6.18: Test Requirements for spectrum emission mask values, BS maximum output power $P \geq 43$ dBm

Frequency offset of measurement filter centre frequency, f_{offset}	Maximum level	Measurement bandwidth
$2,515 \text{ MHz} \leq f_{\text{offset}} < 2,715 \text{ MHz}$	-12,5 dBm	30 kHz
$2,715 \text{ MHz} \leq f_{\text{offset}} < 3,515 \text{ MHz}$	$-12,5 \text{ dBm} - 15 \cdot \left(\frac{f_{\text{offset}}}{\text{MHz}} - 2,715 \right) \text{ dB}$	30 kHz
$3,515 \text{ MHz} \leq f_{\text{offset}} < 4,0 \text{ MHz}$	-24,5 dBm	30 kHz
$4,0 \text{ MHz} \leq f_{\text{offset}} < 8,0 \text{ MHz}$	-11,5 dBm	1 MHz
$8,0 \text{ MHz} \leq f_{\text{offset}} < f_{\text{offset}_{\text{max}}}$	-11,5 dBm	1 MHz

**Table 6.19: Test Requirements for spectrum emission mask values,
BS maximum output power $39 \leq P < 43$ dBm**

Frequency offset of measurement filter centre frequency, f_{offset}	Maximum level	Measurement bandwidth
$2,515 \text{ MHz} \leq f_{\text{offset}} < 2,715 \text{ MHz}$	-12,5 dBm	30 kHz
$2,715 \text{ MHz} \leq f_{\text{offset}} < 3,515 \text{ MHz}$	$-12,5\text{dBm} - 15 \cdot \left(\frac{f_{\text{offset}}}{\text{MHz}} - 2,715 \right) \text{dB}$	30 kHz
$3,515 \text{ MHz} \leq f_{\text{offset}} < 4,0 \text{ MHz}$	-24,5 dBm	30 kHz
$4,0 \text{ MHz} \leq f_{\text{offset}} < 8,0 \text{ MHz}$	-11,5 dBm	1 MHz
$8,0 \text{ MHz} \leq f_{\text{offset}} < f_{\text{offset}_{\text{max}}}$	$P - 54,5 \text{ dB}$	1 MHz

**Table 6.20: Test Requirements for spectrum emission mask values,
BS maximum output power $31 \leq P < 39$ dBm**

Frequency offset of measurement filter centre frequency, f_{offset}	Maximum level	Measurement bandwidth
$2,515 \text{ MHz} \leq f_{\text{offset}} < 2,715 \text{ MHz}$	$P - 51,5 \text{ dB}$	30 kHz
$2,715 \text{ MHz} \leq f_{\text{offset}} < 3,515 \text{ MHz}$	$P - 51,5\text{dB} - 15 \cdot \left(\frac{f_{\text{offset}}}{\text{MHz}} - 2,715 \right) \text{dB}$	30 kHz
$3,515 \text{ MHz} \leq f_{\text{offset}} < 4,0 \text{ MHz}$	$P - 63,5 \text{ dB}$	30 kHz
$4,0 \text{ MHz} \leq f_{\text{offset}} < 8,0 \text{ MHz}$	$P - 50,5 \text{ dB}$	1 MHz
$8,0 \text{ MHz} \leq f_{\text{offset}} < f_{\text{offset}_{\text{max}}}$	$P - 54,5 \text{ dB}$	1 MHz

**Table 6.21: Test Requirements for spectrum emission mask values,
BS maximum output power $P < 31$ dBm**

Frequency offset of measurement filter centre frequency, f_{offset}	Maximum level	Measurement bandwidth
$2,515 \text{ MHz} \leq f_{\text{offset}} < 2,715 \text{ MHz}$	-20,5 dBm	30 kHz
$2,715 \text{ MHz} \leq f_{\text{offset}} < 3,515 \text{ MHz}$	$-20,5\text{dBm} - 15 \cdot \left(\frac{f_{\text{offset}}}{\text{MHz}} - 2,715 \right) \text{dB}$	30 kHz
$3,515 \text{ MHz} \leq f_{\text{offset}} < 4,0 \text{ MHz}$	-32,5 dBm	30 kHz
$4,0 \text{ MHz} \leq f_{\text{offset}} < 8,0 \text{ MHz}$	-19,5 dBm	1 MHz
$8,0 \text{ MHz} \leq f_{\text{offset}} < f_{\text{offset}_{\text{max}}}$	-23,5 dBm	1 MHz

6.6.2.1.5.2 1,28 Mcps TDD option

The spectrum emissions measured according to subclause 6.6.2.1.4.2.2 shall be within the mask defined in the table 6.18A to 6.21A.

Table 6.18A: Test requirements for spectrum emission mask values, BS maximum output power $P \geq 34$ dBm for 1,28 Mcps TDD

Frequency offset of measurement filter centre frequency, f_{offset}	Maximum level	Measurement bandwidth
$0,815\text{MHz} \leq f_{\text{offset}} < 1,015\text{MHz}$	-18.5 dBm	30 kHz
$1,015\text{MHz} \leq f_{\text{offset}} < 1,815\text{MHz}$	$-18,5\text{dBm} - 10 \cdot \left(\frac{f_{\text{offset}}}{\text{MHz}} - 1,015 \right) \text{dB}$	30 kHz
$1,815\text{MHz} \leq f_{\text{offset}} < 2,3\text{MHz}$	-26.5 dBm	30 kHz
$2,3\text{MHz} \leq f_{\text{offset}} < f_{\text{offset}_{\text{max}}}$	-11.5 dBm	1 MHz

Table 6.19A: Test requirements for spectrum emission mask values, BS maximum output power $26 \leq P < 34$ dBm for 1,28 Mcps TDD

Frequency offset of measurement filter centre frequency, f_{offset}	Maximum level	Measurement bandwidth
$0.815\text{MHz} \leq f_{\text{offset}} < 1.015\text{MHz}$	P-52.5 dB	30 kHz
$1.015\text{MHz} \leq f_{\text{offset}} < 1.815\text{MHz}$	$P - 52.5\text{dB} - 10 \cdot \left(\frac{f_{\text{offset}}}{\text{MHz}} - 1.015 \right) \text{dB}$	30 kHz
$1.815\text{MHz} \leq f_{\text{offset}} < 2.3\text{MHz}$	P-60.5 dB	30 kHz
$2.3\text{MHz} \leq f_{\text{offset}} < f_{\text{offset}_{\text{max}}}$	P - 45.5 dB	1 MHz

Table 6.21A: Test requirements for spectrum emission mask values, BS maximum output power $P < 26$ dBm for 1,28 Mcps TDD

Frequency offset of measurement filter centre frequency, f_{offset}	Maximum level	Measurement bandwidth
$0.815\text{MHz} \leq f_{\text{offset}} < 1.015\text{MHz}$	-26.5 dBm	30 kHz
$1.015\text{MHz} \leq f_{\text{offset}} < 1.815\text{MHz}$	$-26.5\text{dBm} - 10 \cdot \left(\frac{f_{\text{offset}}}{\text{MHz}} - 1.015 \right) \text{dB}$	30 kHz
$1.815\text{MHz} \leq f_{\text{offset}} < 2.3\text{MHz}$	-34.5 dBm	30 kHz
$2.3\text{MHz} \leq f_{\text{offset}} < f_{\text{offset}_{\text{max}}}$	-19.5 dBm	1 MHz

6.6.2.1.5.3 1,28 Mcps TDD option - 16QAM capable BS

The spectrum emissions measured according to subclause 6.6.2.1.4.2.3 shall be within the mask defined in the table 6.18A to 6.21A in section 6.6.2.1.5.2.

6.6.2.1.5.4 3,84 Mcps TDD option - 16QAM capable BS

The spectrum emissions measured according to subclause 6.6.2.1.4.2.4 shall be within the mask defined in the table 6.18 to 6.21 in section 6.6.2.1.5.1.

6.6.2.1.5.5 7,68 Mcps TDD option

The spectrum emissions measured according to subclause 6.6.2.1.4.2.5 shall not exceed the maximum level specified in tables 6.18B to 6.21B for the appropriate BS maximum output power

Table 6.18B: Test Requirements for spectrum emission mask values, BS maximum output power $P \geq 43$ dBm

Frequency offset of measurement filter centre frequency, f_{offset}	Maximum level	Measurement bandwidth
$5.015\text{MHz} \leq f_{\text{offset}} < 5.215\text{MHz}$	-15.5 dBm	30 kHz
$5.215\text{MHz} \leq f_{\text{offset}} < 6.015\text{MHz}$	$-15.5\text{dBm} - 15 \cdot \left(\frac{f_{\text{offset}}}{\text{MHz}} - 5.215 \right) \text{dB}$	30 kHz
$6.015\text{MHz} \leq f_{\text{offset}} < 6.5\text{MHz}$	-27.5 dBm	30 kHz
$6.5\text{MHz} \leq f_{\text{offset}} < f_{\text{offset}_{\text{max}}}$	-14.5 dBm	1 MHz
$15.5\text{MHz} \leq f_{\text{offset}} < f_{\text{offset}_{\text{max}}}$	-14.5 dBm	1 MHz

**Table 6.19B: Test Requirements for spectrum emission mask values,
BS maximum output power $39 \leq P < 43$ dBm**

Frequency offset of measurement filter centre frequency, f_{offset}	Maximum level	Measurement bandwidth
$5.015\text{MHz} \leq f_{\text{offset}} < 5.215\text{MHz}$	-15.5 dBm	30 kHz
$5.215\text{MHz} \leq f_{\text{offset}} < 6.015\text{MHz}$	$-15.5\text{dBm} - 15 \cdot \left(\frac{f_{\text{offset}}}{\text{MHz}} - 5.215 \right) \text{dB}$	30 kHz
$6.015\text{MHz} \leq f_{\text{offset}} < 6.5\text{MHz}$	-27.5 dBm	30 kHz
$6.5\text{MHz} \leq f_{\text{offset}} < 15.5\text{MHz}$	-14.5 dBm	1 MHz
$15.5\text{MHz} \leq f_{\text{offset}} < f_{\text{offset}_{\text{max}}}$	$P - 57.5$ dB	1 MHz

**Table 6.20B: Test Requirements for spectrum emission mask values,
BS maximum output power $31 \leq P < 39$ dBm**

Frequency offset of measurement filter centre frequency, f_{offset}	Maximum level	Measurement bandwidth
$5.015\text{MHz} \leq f_{\text{offset}} < 5.215\text{MHz}$	$P - 54.5$ dB	30 kHz
$5.215\text{MHz} \leq f_{\text{offset}} < 6.015\text{MHz}$	$P - 54.5\text{dB} - 15 \cdot \left(\frac{f_{\text{offset}}}{\text{MHz}} - 5.215 \right) \text{dB}$	30 kHz
$6.015\text{MHz} \leq f_{\text{offset}} < 6.5\text{MHz}$	$P - 66.5$ dB	30 kHz
$6.5\text{MHz} \leq f_{\text{offset}} < 15.5\text{MHz}$	$P - 53.5$ dB	1 MHz
$15.5\text{MHz} \leq f_{\text{offset}} < f_{\text{offset}_{\text{max}}}$	$P - 57.5$ dB	1 MHz

**Table 6.21B: Test Requirements for spectrum emission mask values,
BS maximum output power $P < 31$ dBm**

Frequency offset of measurement filter centre frequency, f_{offset}	Maximum level	Measurement bandwidth
$5.015\text{MHz} \leq f_{\text{offset}} < 5.215\text{MHz}$	-23.5 dBm	30 kHz
$5.215\text{MHz} \leq f_{\text{offset}} < 6.015\text{MHz}$	$-23.5\text{dBm} - 15 \cdot \left(\frac{f_{\text{offset}}}{\text{MHz}} - 5.215 \right) \text{dB}$	30 kHz
$6.015\text{MHz} \leq f_{\text{offset}} < 6.5\text{MHz}$	-35.5 dBm	30 kHz
$6.5\text{MHz} \leq f_{\text{offset}} < 15.5\text{MHz}$	-22.5 dBm	1 MHz
$15.5\text{MHz} \leq f_{\text{offset}} < f_{\text{offset}_{\text{max}}}$	-26.5 dBm	1 MHz

6.6.2.1.5.6 7,68 Mcps TDD option - 16QAM capable BS

The spectrum emissions measured according to subclause 6.6.2.1.4.2.6 shall be within the mask defined in the table 6.18B to 6.21B in section 6.6.2.1.5.5.

6.6.2.2 Adjacent Channel Leakage power Ratio (ACLR)

6.6.2.2.1 Definition and applicability

Adjacent Channel Leakage power Ratio (ACLR) is the ratio of the RRC filtered mean power centered on the assigned channel frequency to the RRC filtered mean power centered on an adjacent channel frequency. The requirements shall apply for all configurations of BS (single carrier or multi-carrier), and for all operating modes foreseen by the manufacturer's specification.

In some cases the requirement is expressed as adjacent channel leakage power, which is the RRC filtered mean power for the given bandwidth of the victim system at the defined adjacent channel offset.

6.6.2.2.2 Minimum Requirements

6.6.2.2.2.1 Minimum requirement

6.6.2.2.2.1.1 3,84 Mcps TDD option

The ACLR of a single carrier BS or a multi-carrier BS with contiguous carrier frequencies shall be equal to or greater than the limits given in table 6.22.

Table 6.22: BS ACLR limits

BS adjacent channel offset below the first or above the last carrier frequency used	ACLR limit
5 MHz	45 dB
10 MHz	55 dB

If a BS provides multiple non-contiguous single carriers or multiple non-contiguous groups of contiguous single carriers, the above requirements shall be applied individually to the single carriers or group of single carriers.

The normative reference for this requirement is TS 25.105 [1] subclause 6.6.2.2.1.1.

6.6.2.2.2.1.2 1,28 Mcps TDD option

The ACLR of a single carrier BS or a multi-carrier BS with contiguous carrier frequencies shall be equal to or greater than the limits given in Table 6.22A.

Table 6.22A: BS ACLR limits for 1,28 Mcps TDD

BS adjacent channel offset below the first or above the last carrier frequency used	ACLR limit
1,6 MHz	40 dB
3,2 MHz	45 dB

If a BS provides multiple non-contiguous single carriers or multiple non-contiguous groups of contiguous single carriers, the above requirements shall be applied individually to the single carriers or group of single carriers.

The normative reference for this requirement is TS 25.105 [1] subclause 6.6.2.2.1.2

6.6.2.2.2.1.3 7,68 Mcps TDD option

The ACLR of a single carrier BS or a multi-carrier BS with contiguous carrier frequencies shall be equal to or greater than the limits given in table 6.22B.

Table 6.22B: BS ACLR limits

BS adjacent channel offset below the first or above the last carrier frequency used	ACLR limit
10 MHz	45 dB
20 MHz	55 dB

If a BS provides multiple non-contiguous single carriers or multiple non-contiguous groups of contiguous single carriers, the above requirements shall be applied individually to the single carriers or group of single carriers.

The normative reference for this requirement is TS 25.105 [1] subclause 6.6.2.2.1.3.

6.6.2.2.2.2	Void
6.6.2.2.2.2.1	Void
6.6.2.2.2.2.1.1	Void
6.6.2.2.2.2.1.2	Void
6.6.2.2.2.2.2	Void
6.6.2.2.2.2.2.1	Void
6.6.2.2.2.2.2.2	Void
6.6.2.2.2.2.3	Void
6.6.2.2.2.2.3.1	Void
6.6.2.2.2.2.3.2	Void
6.6.2.2.2.3	Void
6.6.2.2.2.3.1	Void
6.6.2.2.2.3.1.1	Void
6.6.2.2.2.3.1.2	Void
6.6.2.2.2.3.2	Void
6.6.2.2.2.3.2.1	Void
6.6.2.2.2.3.2.2	Void
6.6.2.2.2.3.3	Void
6.6.2.2.2.3.3.1	Void
6.6.2.2.2.3.3.2	Void

6.6.2.2.3 Test purpose

The test purpose is to verify the ability of the BS to limit the interference produced by the transmitted signal to other UTRA receivers operating at the first or second adjacent RF channel.

6.6.2.2.4 Method of test

6.6.2.2.4.1 Initial conditions

For 3,84 Mcps BS supporting 16QAM, the ALCR requirements shall be tested with the general test set up specified in section 6.6.2.2.4.1.1 and also with the special test set up for 16QAM capable BS specified in section 6.6.2.2.4.1.4.

For 1,28 Mcps BS supporting 16QAM, the ALCR requirements shall be tested with the general test set up specified in section 6.6.2.2.4.1.2 and also with the special test set up for 16QAM capable BS specified in section 6.6.2.2.4.1.3.

For 7,68 Mcps BS supporting 16QAM, the ACLR requirements shall be tested with the general test set up specified in section 6.6.2.2.4.1.5 and also with the special test set up for 16QAM capable BS specified in section 6.6.2.2.4.1.6.

6.6.2.2.4.1.0 General test conditions

Test environment: normal; see subclause 5.9.1.

RF channels to be tested: B, M and T with multiple carriers if supported; see subclause 5.3.

6.6.2.2.4.1.1 3,84 Mcps TDD option - General test set up

- (1) Connect the measuring equipment to the antenna connector of the BS under test.
- (2) Set the parameters of the BS transmitted signal according to table 6.25. For MBSFN IMB operation the set of parameters for the transmitted signals is according to IMB test model 1 in subclause 6.1.1.1.

Table 6.25: Parameters of the BS transmitted signal for ACLR testing

Parameter	Value/description
TDD Duty Cycle	TS i ; $i = 0, 1, 2, \dots, 14$: transmit, if i is even; receive, if i is odd.
Time slot carrying SCH	TS0
Time slots under test	TS i , i even and non zero
BS output power setting	PRAT
Number of DPCH in each time slot under test	9
Power of each DPCH	1/9 of Base Station output power
Data content of DPCH	Real life (sufficient irregular)

6.6.2.2.4.1.2 1,28 Mcps TDD option - General test set up

- (1) Connect the measuring equipment to the antenna connector of the BS under test.
- (2) Set the parameters of the BS transmitted signal according to table 6.25A.

Table 6.25A: Parameters of the BS transmitted signal for ACLR testing for 1,28 Mcps TDD

Parameter	Value/description
TDD Duty Cycle	TS i ; $i = 0, 1, 2, 3, 4, 5, 6$: transmit, if i is 0,4,5,6; receive, if i is 1,2,3.
Time slots under test	TS4, TS5 and TS6
BS output power setting	PRAT
Number of DPCH in each time slot under test	8
Power of each DPCH	1/8 of Base Station output power
Data content of DPCH	real life (sufficient irregular)

6.6.2.2.4.1.3 1,28 Mcps TDD option - Special test set up for 16QAM capable BS

This test set up only applies for 16QAM capable BS.

- (1) Connect the measuring equipment to the antenna connector of the BS under test.
- (2) Set the parameters of the BS transmitted signal according to table 6.25B.

Table 6.25B: Parameters of the BS transmitted signal for ACLR testing for 1,28 Mcps TDD- 16QAM capable BS

Parameter	Value/description
TDD Duty Cycle	TS i ; $i = 0, 1, 2, 3, 4, 5, 6$: transmit, if i is 0,4,5,6; receive, if i is 1,2,3.
Time slots under test	TS4, TS5 and TS6
BS output power setting	PRAT
HS-PDSCH modulation	16QAM
Number of HS-PDSCH in each time slot under test	8
Power of each HS-PDSCH	1/8 of Base Station output power
Data content of HS-PDSCH	real life (sufficient irregular)
Spreading factor	16

6.6.2.2.4.1.4 3,84 Mcps TDD option - Special test set up for 16QAM capable BS

This test set up only applies for 16QAM capable BS.

- (1) Connect the measuring equipment to the antenna connector of the BS under test.
- (2) Set the parameters of the BS transmitted signal according to table 6.25C. For MBSFN IMB operation the set of parameters for the transmitted signals is according to IMB test model 2 in subclause 6.1.1.2.

Table 6.25C: Parameters of the BS transmitted signal for ACLR testing - 16QAM capable BS

Parameter	Value/description
TDD Duty Cycle	TS i ; $i = 0, 1, 2, \dots, 14$: transmit, if i is even; receive, if i is odd.
Time slot carrying SCH	TS0
Time slots under test	TS i , i even and non zero
BS output power setting	PRAT
HS-PDSCH modulation	16QAM
Number of HS-PDSCH in each time slot under test	9
Power of each HS-PDSCH	1/9 of Base Station output power
Data content of HS-PDSCH	real life (sufficient irregular)
Spreading factor	16

6.6.2.2.4.1.5 7,68 Mcps TDD option - General test set up

- (1) Connect the measuring equipment to the antenna connector of the BS under test.
- (2) Set the parameters of the BS transmitted signal according to table 6.25D.

Table 6.25D: Parameters of the BS transmitted signal for ACLR testing

Parameter	Value/description
TDD Duty Cycle	TS i ; $i = 0, 1, 2, \dots, 14$: transmit, if i is even; receive, if i is odd.
Time slot carrying SCH	TS0
Time slots under test	TS i , i even and non zero
BS output power setting	PRAT
Number of DPCH in each time slot under test	9
Power of each DPCH	1/9 of Base Station output power
Data content of DPCH	Real life (sufficient irregular)

6.6.2.2.4.1.6 7,68 Mcps TDD option - Special test set up for 16QAM capable BS

This test set up only applies for 16QAM capable BS.

- (1) Connect the measuring equipment to the antenna connector of the BS under test.
- (2) Set the parameters of the BS transmitted signal according to table 6.25E.

Table 6.25E: Parameters of the BS transmitted signal for ACLR testing - 16QAM capable BS

Parameter	Value/description
TDD Duty Cycle	TS i ; $i = 0, 1, 2, \dots, 14$: transmit, if i is even; receive, if i is odd.
Time slot carrying SCH	TS0
Time slots under test	TS i , i even and non zero
BS output power setting	PRAT
HS-PDSCH modulation	16QAM
Number of HS-PDSCH in each time slot under test	9
Power of each HS-PDSCH	1/9 of Base Station output power
Data content of HS-PDSCH	real life (sufficient irregular)
Spreading factor	32

6.6.2.2.4.2 Procedure

6.6.2.2.4.2.1 3,84 Mcps TDD option

- 1) Measure the RRC filtered mean power centered on the lowest assigned channel frequency over the 2464 active chips of the even time slots TS i (this excludes the guard period).
- 2) Average over TBD time slots.
- 3) Measure the RRC filtered mean power at the first lower adjacent RF channel (center frequency 5 MHz below the lowest assigned channel frequency of the transmitted signal) over the useful part of the burst within the even time slots TS i (this excludes the guard period).
- 4) Average over TBD time slots.
- 5) Calculate the ACLR by the ratio

$$\text{ACLR} = \text{average acc. to (2)} / \text{average interference power acc. to (4)}.$$

- 6) Repeat steps (3), (4) and (5) for the second lower adjacent RF channel (center frequency 10 MHz below the lowest assigned channel frequency of the transmitted signal).
- 7) In case of a multi-carrier Bs, repeat steps (1) and (2) for the highest assigned channel frequency. Otherwise, use the result obtained in step (2) above for further calculation in step (10).
- 8) Measure the RRC filtered mean power at the first higher adjacent RF channel (center frequency 5 MHz above the highest assigned channel frequency of the transmitted signal) over the useful part of the burst within the even time slots TS i (this excludes the guard period).
- 9) Average over TBD time slots.
- 10) Calculate the ACLR by the ratio

$$\text{ACLR} = \text{average power acc. to (7)} / \text{average interference power acc. to (9)}.$$

- 11) Repeat steps (8) to (10) for the second upper adjacent RF channel (center frequency 10 MHz above the highest assigned channel frequency of the transmitted signal).

6.6.2.2.4.2.2 1,28 Mcps TDD option

- 1) Measure the RRC filtered mean power centered on the lowest assigned channel frequency over the 848 active chips of the transmit time slots TS_i (this excludes the guard period).
- 2) Average over at least one time slot.
- 3) Measure the RRC filtered mean power at the first lower adjacent RF channel (center frequency 1,6 MHz below the assigned channel frequency of the transmitted signal) over the useful part of the burst within the transmit time slots TS_i (this excludes the guard period).
- 4) Average over at least one time slot.
- 5) Calculate the ACLR by the ratio:

$$\text{ACLR} = \text{average power acc. to (2)} / \text{average interference power acc. to (4)}.$$

- 6) Repeat steps (3), (4) and (5) for the second lower adjacent RF channel (center frequency 3,2 MHz below the lowest assigned channel frequency of the transmitted signal) and also for the first and second upper adjacent RF channel (center frequency 1,6 MHz and 3,2 MHz above the assigned channel frequency of the transmitted signal, respectively).
- 7) In case of a multi-carrier BS, repeat steps (1) and 2 for the highest assigned channel frequency. Otherwise, use the result obtained in step (2) above for further calculation in step (10).
- 8) Measure the RRC filtered mean power at the first higher adjacent RF channel (center frequency 1,6 MHz above the highest assigned channel frequency of the transmitted signal) over the useful part of the burst within the transmit time slots TS_i (this excludes the guard period).
- 9) Average over at least one time slot.
- 10) Calculate the ACLR by the ratio

$$\text{ACLR} = \text{average power acc. to (7)} / \text{average interference power acc. to (9)}.$$

- 11) Repeat steps (8) to (10) for the second upper adjacent RF channel (center frequency 3,2 MHz above the highest assigned channel frequency of the transmitted signal).

6.6.2.2.4.2.3 1,28 Mcps TDD option - 16QAM capable BS

The same procedure specified in 6.6.2.2.4.2.2 applies to 1,28 Mcps TDD option BS supporting 16QAM.

6.6.2.2.4.2.4 3,84 Mcps TDD option - 16QAM capable BS

The same procedure specified in 6.6.2.2.4.2.1 applies to 3,84 Mcps TDD option BS supporting 16QAM.

6.6.2.2.4.2.5 7,68 Mcps TDD option

- 1) Measure the RRC filtered mean power centered on the lowest assigned channel frequency over the 4928 active chips of the even time slots TS_i (this excludes the guard period).
- 2) Average over TBD time slots.
- 3) Measure the RRC filtered mean power at the first lower adjacent RF channel (center frequency 10 MHz below the lowest assigned channel frequency of the transmitted signal) over the useful part of the burst within the even time slots TS_i (this excludes the guard period).
- 4) Average over TBD time slots.
- 5) Calculate the ACLR by the ratio

$$\text{ACLR} = \text{average acc. to (2)} / \text{average interference power acc. to (4)}.$$

- 6) Repeat steps (3), (4) and (5) for the second lower adjacent RF channel (center frequency 20 MHz below the lowest assigned channel frequency of the transmitted signal).

- 7) In case of a multi-carrier Bs, repeat steps (1) and (2) for the highest assigned channel frequency. Otherwise, use the result obtained in step (2) above for further calculation in step (10).
- 8) Measure the RRC filtered mean power at the first higher adjacent RF channel (center frequency 10 MHz above the highest assigned channel frequency of the transmitted signal) over the useful part of the burst within the even time slots TS i (this excludes the guard period).
- 9) Average over TBD time slots.
- 10) Calculate the ACLR by the ratio

$$\text{ACLR} = \text{average power acc. to (7)} / \text{average interference power acc. to (9)}.$$

- 11) Repeat steps (8) to (10) for the second upper adjacent RF channel (center frequency 20 MHz above the highest assigned channel frequency of the transmitted signal).

6.6.2.2.4.2.6 7,68 Mcps TDD option - 16QAM capable BS

The same procedure specified in 6.6.2.2.4.2.5 applies to 7,68 Mcps TDD option BS supporting 16QAM.

6.6.2.2.5 Test Requirements

NOTE: If the Test Requirements below differ from the Minimum Requirements, then the Test Tolerance applied for this test is non-zero. The Test Tolerance for this test is defined in subclause 5.11 and the explanation of how the Minimum Requirement has been relaxed by the Test Tolerance is given in Annex D.

6.6.2.2.5.1 3,84 Mcps TDD option

The ACLR calculated in steps (5) and (10) of subclause 6.6.2.2.4.2.1 shall be equal or greater than the limits given in table 6.26. In case the equipment is tested against the requirements defined for operation in the same geographic area or co-sited with unsynchronised TDD or FDD on adjacent channels, the adjacent channel leakage power measured according to steps (4) and (9) of subclause 6.6.2.2.4.2.1 shall not exceed the maximum levels specified in table 6.27, 6.27A, 6.28 or 6.28A, respectively.

Table 6.26: BS ACLR Test Requirements

BS adjacent channel offset below the first or above the last carrier frequency used	ACLR limit
5 MHz	44,2 dB
10 MHz	54,2 dB

6.6.2.2.5.2 1,28 Mcps TDD option

The ACLR calculated in steps (5) and (10) of subclause 6.6.2.2.4.2.2 shall be equal or greater than the limits given in table 6.26A. In case the equipment is tested against the requirements defined for operation in the same geographic area or co-sited with unsynchronised TDD or FDD on adjacent channels, the adjacent channel leakage power measured according to steps (3) and (4) of subclause 6.6.2.2.4.2.2 shall not exceed the maximum levels specified in tables 6.27B, 6.27C, 6.27D, 6.28B, 6.28C or 6.28D, respectively.

Table 6.26A: BS ACLR Test Requirements (1,28 Mcps option)

BS adjacent channel offset below the first or above the last carrier frequency used	ACLR limit
1,6 MHz	39.2 dB
3,2 MHz	44.2 dB

6.6.2.2.5.3 1,28 Mcps TDD option - 16QAM capable BS

The same test requirements specified in section 6.6.2.2.5.2 apply to 1,28 Mcps TDD option BS supporting 16QAM.

6.6.2.2.5.4 3,84 Mcps TDD option - 16QAM capable BS

The same test requirements specified in section 6.6.2.2.5.1 apply to 3,84 Mcps TDD option BS supporting 16QAM.

6.6.2.2.5.5 7,68 Mcps TDD option

The ACLR calculated in steps (5) and (10) of subclause 6.6.2.2.4.2.5 shall be equal or greater than the limits given in table 6.26B. In case the equipment is tested against the requirements defined for operation in the same geographic area or co-sited with unsynchronised TDD or FDD on adjacent channels, the adjacent channel leakage power measured according to steps (4) and (9) of subclause 6.6.2.2.4.2.5 shall not exceed the maximum levels specified in table 6.27E, 6.27F, 6.27G, 6.28E, 6.28F or 6.28G, respectively.

Table 6.26B: BS ACLR Test Requirements

BS adjacent channel offset below the first or above the last carrier frequency used	ACLR limit
10 MHz	44,2 dB
20 MHz	54,2 dB

6.6.2.2.5.6 7,68 Mcps TDD option - 16QAM capable BS

The same test requirements specified in section 6.6.2.2.5.5 apply to 7,68 Mcps TDD option BS supporting 16QAM.

6.6.3 Spurious emissions

6.6.3.1 Definition and applicability

Spurious emissions are emissions which are caused by unwanted transmitter effects such as harmonics emission, parasitic emission, intermodulation products and frequency conversion products, but exclude out of band emissions. This is measured at the base station antenna connector.

The requirements shall apply whatever the type of transmitter considered (single carrier or multiple carrier). It applies for all transmission modes foreseen by the manufacturer's specification.

For 3,84 Mcps TDD option, either requirement (except 6.6.3.2.6) applies at frequencies within the specified frequency ranges which are more than 12,5 MHz under the first carrier frequency used or more than 12,5 MHz above the last carrier frequency used.

For 1,28 Mcps TDD option, either requirement applies at frequencies within the specified frequency ranges which are more than 4 MHz under the first carrier frequency used or more than 4 MHz above the last carrier frequency used.

For 7,68 Mcps TDD option, either requirement (except 6.6.3.2.6) applies at frequencies within the specified frequency ranges which are more than 25 MHz under the first carrier frequency used or more than 25 MHz above the last carrier frequency used.

Unless otherwise stated, all requirements are measured as mean power.

The requirements in this subclause shall apply to both Wide Area BS and Local Area BS, with the exception of the requirements which may be applied for co-existence with UTRA FDD; in this case, different requirements shall apply to Wide Area BS and Local Area BS.

6.6.3.2 Minimum Requirements

6.6.3.2.1 Mandatory requirements

The requirements of either subclause 6.6.3.2.1.1 or subclause 6.6.3.2.1.2 shall apply.

6.6.3.2.1.1 Spurious emissions (Category A)

The following requirements shall be met in cases where Category A limits for spurious emissions, as defined in ITU-R Recommendation SM.329 [6], are applied.

6.6.3.2.1.1.1 3,84 Mcps TDD option

The power of any spurious emission shall not exceed the maximum level given in Table 6.29.

Table 6.29: BS Mandatory spurious emissions limits, Category A

Band	Maximum level	Measurement bandwidth	Notes
9 kHz - 150 kHz	-13 dBm	1 kHz	Note 1
150 kHz - 30 MHz		10 kHz	Note 1
30 MHz - 1 GHz		100 kHz	Note 1
1 GHz - 12,75 GHz		1 MHz	Note 2
NOTE 1: Bandwidth as in ITU-R SM.329 [6], s4.1			
NOTE 2: Upper frequency as in ITU-R SM.329 [6], s2.5 table 1			

The normative reference for this requirement is TS 25.105 [1] subclause 6.6.3.1.1.1.1.

6.6.3.2.1.1.2 1,28 Mcps TDD option

The power of any spurious emission shall not exceed the maximum level given in Table 6.29A.

Table 6.29A: BS Mandatory spurious emissions limits, Category A

Band	Maximum level	Measurement bandwidth	Notes
9 kHz - 150 kHz	-13 dBm	1 kHz	Note 1
150 kHz - 30 MHz		10 kHz	Note 1
30 MHz - 1 GHz		100 kHz	Note 1
1 GHz - 12,75 GHz		1 MHz	Note 2
NOTE 1: Bandwidth as in ITU-R SM.329 [6], s4.1			
NOTE 2: Upper frequency as in ITU-R SM.329 [6], s2.5 table 1			

The normative reference for this requirement is TS 25.105 [1] subclause 6.6.3.1.1.1.2.

6.6.3.2.1.1.3 7,68 Mcps TDD option

The power of any spurious emission shall not exceed the maximum level given in Table 6.29B.

Table 6.29B: BS Mandatory spurious emissions limits, Category A

Band	Maximum level	Measurement bandwidth	Notes
9 kHz - 150 kHz	-13 dBm	1 kHz	Note 1
150 kHz - 30 MHz		10 kHz	Note 1
30 MHz - 1 GHz		100 kHz	Note 1
1 GHz - 12,75 GHz		1 MHz	Note 2
NOTE 1: Bandwidth as in ITU-R SM.329 [6], s4.1			
NOTE 2: Upper frequency as in ITU-R SM.329 [6], s2.5 table 1			

The normative reference for this requirement is TS 25.105 [1] subclause 6.6.3.1.1.1.3.

6.6.3.2.1.2 Spurious emissions (Category B)

The following requirements shall be met in cases where Category B limits for spurious emissions, as defined in ITU-R Recommendation SM.329-9 [6], are applied.

6.6.3.2.1.2.1 3,84 Mcps TDD option

The power of any spurious emission shall not exceed the maximum levels given in Table 6.30.

Table 6.30: BS Mandatory spurious emissions limits, Category B

Band	Maximum level	Measurement bandwidth	Notes
9 kHz - 150 kHz	-36 dBm	1 kHz	Note 1
150 kHz - 30 MHz	-36 dBm	10 kHz	Note 1
30 MHz - 1 GHz	-36 dBm	100 kHz	Note 1
1 GHz - Fl - 10 MHz	-30 dBm	1 MHz	Note 1
Fl -10 MHz- Fu +10 MHz	-15 dBm	1 MHz	Note 2
Fu + 10 MHz - 12,75 GHz	-30 dBm	1 MHz	Note 3
NOTE 1: Bandwidth as in ITU-R SM.329 [6], s4.1			
NOTE 2: Specification in accordance with ITU-R SM.329 [6], s4.3 and Annex 7			
NOTE 3: Bandwidth as in ITU-R SM.329 [6], s4.1. Upper frequency as in ITU-R SM.329 [6], s2.5 table 1			

Fl: Lower frequency of the band in which TDD operates

Fu: Upper frequency of the band in which TDD operates

The normative reference for this requirement is TS 25.105 [1] subclause 6.6.3.1.2.1.1.

6.6.3.2.1.2.2 1,28 Mcps TDD option

The power of any spurious emission shall not exceed the maximum levels given in Table 6.30A.

Table 6.30A: BS Mandatory spurious emissions limits, Category B for 1,28 Mcps TDD

Band	Maximum Level	Measurement Bandwidth	Notes
9kHz - 150kHz	-36 dBm	1 kHz	Note 1
150kHz - 30MHz	-36 dBm	10 kHz	Note 1
30MHz - 1GHz	-36 dBm	100 kHz	Note 1
1GHz ↔ Fl -10 MHz	-30 dBm	1 MHz	Note 1
Fl -10 MHz↔Fu +10 MHz	-15 dBm	1 MHz	Note 2
Fu +10 MHz ↔ 12,75 GHz	-30 dBm	1 MHz	Note 3
NOTE 1: Bandwidth as in ITU-R SM.329 [6], s4.1			
NOTE 2: Specification in accordance with ITU-R SM.329 [6], s4.1			
NOTE 3: Bandwidth as in ITU-R SM.329-9, s4.1. Upper frequency as in ITU-R SM.329-9, s2.5 table 1			

Fl: Lower frequency of the band in which TDD operates

Fu: Upper frequency of the band in which TDD operates

The reference for this requirement is TS 25.105 subclause 6.6.3.1.2.1.2.

6.6.3.2.1.2.3 7,68 Mcps TDD option

The power of any spurious emission shall not exceed the maximum levels given in Table 6.30B.

Table 6.30B: BS Mandatory spurious emissions limits, Category B

Band	Maximum Level	Measurement Bandwidth	Notes
9kHz - 150kHz	-36 dBm	1 kHz	Note 1
150kHz - 30MHz	- 36 dBm	10 kHz	Note 1
30MHz - 1GHz	-36 dBm	100 kHz	Note 1
1GHz ↔ FI -10 MHz	-30 dBm	1 MHz	Note 1
FI -10 MHz↔Fu +10 MHz	-15 dBm	1 MHz	Note 2
Fu + 10 MHz ↔ 12,75 GHz	-30 dBm	1 MHz	Note 3
NOTE 1: Bandwidth as in ITU SM.329 [6], s4.1 NOTE 2: Specification in accordance with ITU-R SM.329 [6], s4.3 and Annex 7 NOTE 3: Bandwidth as in ITU-R SM.329 [6], s4.3 and Annex 7. Upper frequency as in ITU-R SM.329 [6], s2.5 table 1			

Fl: Lower frequency of the band in which TDD operates

Fu: Upper frequency of the band in which TDD operates

The normative reference for this requirement is TS 25.105 [1] subclause 6.6.3.1.2.1.3.

6.6.3.2.2 Co-existence with GSM, DCS, UTRA and/or E-UTRA

6.6.3.2.2.1 Operation in the same geographic area

These requirements may be applied for the protection of UE, MS and/or BS operating in other frequency bands in the same geographical area. The requirements may apply in geographic areas in which both a UTRA FDD BS and a system operating in another frequency band than the FDD operating band are deployed. The system operating in the other frequency band may be GSM, DCS, E-UTRA and/or UTRA.

The power of any spurious emission shall not exceed the maximum level given in Table 6.31.

Table 6.31: BS Spurious emissions limits for UTRA TDD BS in geographic coverage area of systems operating in other frequency bands

System type operating in the same geographical area	Band	Maximum level	Measurement bandwidth	Note
GSM900	876 MHz - 915 MHz	-61 dBm	100 kHz	
	921 MHz - 960 MHz	-57 dBm	100 kHz	
DCS1800	1710 MHz - 1785 MHz	-61 dBm	100 kHz	This requirement does not apply to UTRA TDD operating in Band b and c. For UTRA TDD BS operating in Band f, it applies for 1710 - 1755 MHz
	1805 MHz - 1880 MHz	-47 dBm	100 kHz	This requirement does not apply to UTRA TDD operating in Band b and c. For UTRA TDD BS operating in Band f, it applies for 1805 - 1850 MHz
GSM850 or CDMA850	824 - 849 MHz	-61 dBm	100 kHz	
	869 - 894 MHz	-57 dBm	100 kHz	
WA BS UTRA FDD Band I or E-UTRA Band 1	1920 - 1980 MHz	-43 dBm (*)	3,84 MHz	
	2110 - 2170 MHz	-52 dBm	1 MHz	
WA BS UTRA FDD Band III or E-UTRA Band 3	1710 - 1785 MHz	-43 dBm	3,84 MHz	For UTRA TDD BS operating in Band f, it applies for 1710- 1755 MHz
	1805 - 1880 MHz	-52 dBm	1 MHz	For UTRA TDD BS operating in Band f, it applies for 1805- 1850 MHz
WA BS UTRA FDD Band V or E-UTRA Band 5	824 - 849 MHz	-43 dBm	3.84 MHz	
	869 - 894 MHz	-52 dBm	1 MHz	
WA BS UTRA FDD Band VII or E-UTRA Band 7	2500 - 2570 MHz	-43 dBm (**)	3.84 MHz	
	2620 - 2690 MHz	-52 dBm	1 MHz	
WA BS UTRA FDD Band VI or XIX, E-UTRA Band 6, 18 or 19	815-850 MHz	-43 dBm †	3,84 MHz	Applicable in Japan
	860-895 MHz	-52 dBm †	1 MHz	Applicable in Japan
WA BS UTRA FDD Band XI or XXI or E-UTRA Band 11 or 21	1427.9MHz - 1452.9MHz	-43 dBm ††	3.84 MHz	Applicable in Japan
	1475.9MHz - 1500.9MHz	-52 dBm ††	1 MHz	Applicable in Japan
WA BS UTRA FDD Band IX or E-UTRA Band 9	1749.9-1784.9 MHz	-43 dBm †	3.84 MHz	Applicable in Japan
	1844.9-1879.9 MHz	-52 dBm †	1 MHz	Applicable in Japan
LA BS UTRA FDD Band I or E-UTRA Band 1	1920 - 1980 MHz	-40 dBm (*)	3,84 MHz	
	2110 - 2170 MHz	-52 dBm	1 MHz	
LA BS UTRA FDD Band III or E-UTRA Band 3	1710 - 1785 MHz	-40 dBm (*)	3,84 MHz	For UTRA TDD BS operating in Band f, it applies for 1710- 1755 MHz
	1805 - 1880 MHz	-52 dBm	1 MHz	For UTRA TDD BS operating in Band f, it applies for 1805- 1850 MHz
LA BS UTRA FDD Band V or E-UTRA Band 5	824 - 849 MHz	-40 dBm (*)	3,84 MHz	
	869 - 894 MHz	-52 dBm	1 MHz	

LA BS UTRA FDD Band VII or E-UTRA Band 7	2500 - 2570 MHz	-40 dBm(**)	3.84 MHz	
<p>NOTE 1: The co-existence requirements do not apply for the 10 MHz frequency range immediately outside the operating band (see section 4.2). Emission limits for this excluded frequency range may be covered by local or regional requirements.</p> <p>NOTE 2: The requirements for Wide Area BS for co-existence with UTRA FDD and/or E-UTRA FDD and for co-existence between unsynchronised TDD base stations are based on a coupling loss of 67dB between the TDD and FDD base stations. The requirements for Local Area BS are based on a coupling loss of 70 dB between TDD and FDD Wide Area base stations and between unsynchronised Wide Area and Local Area TDD base stations. The scenarios leading to these requirements are addressed in TR 25.942 [9].</p> <p>NOTE 3: The table above assumes that two operating bands, where the frequency ranges would be overlapping, are not deployed in the same geographical area. For such a case of operation with overlapping frequency arrangements in the same geographical area, special co-existence requirements may apply that are not covered by the 3GPP specifications.</p>				

The normative reference for this requirement is TS 25.105 [1] subclause 6.6.3.2.1.1.

6.6.3.2.2.2 Co-located base stations

These requirements may be applied for the protection of UE, MS and/or BS operating in other frequency bands in the same geographical area. The requirements may apply in geographic areas in which both a UTRA FDD BS and a system operating in another frequency band than the FDD operating band are deployed. The system operating in the other frequency band may be GSM, DCS, E-UTRA and/or UTRA.

The power of any spurious emission shall not exceed the maximum level given in table 6.32.

Table 6.32: BS Spurious emissions limits for Wide Area BS co-located with another BS

System type operating in the same geographical area	Band	Maximum level	Measurement bandwidth	Note
Macro GSM900	876 MHz - 915 MHz	-98 dBm	100 kHz	
Macro DCS1800	1710 - 1785 MHz	-98 dBm	100 kHz	This requirement does not apply to UTRA TDD operating in Band b and c. For UTRA TDD BS operating in Band f, it applies for 1710 - 1755 MHz
GSM850 or CDMA850	824 - 849 MHz	-98 dBm	100 kHz	
WA BS UTRA FDD Band I or E-UTRA Band 1	1920 - 1980 MHz	-80 dBm (*)	3,84 MHz	
WA BS UTRA FDD Band III or E-UTRA Band 3	1710 - 1785 MHz	-80dBm	3.84 MHz	For UTRA TDD BS operating in Band f, it applies for 1710-1755 MHz.
WA BS UTRA FDD Band V or E-UTRA Band 5	824 - 849 MHz	-80 dBm (*)	3,84 MHz	
WA BS UTRA FDD Band VII or E-UTRA Band 7	2500 - 2570 MHz	- 80 dBm(**)	3.84 MHz	
<p>NOTE 1: The co-location requirements do not apply for the 10 MHz frequency range immediately outside the BS transmit frequency range of the operating band (see section 4.2). The current state-of-the-art technology does not allow a single generic solution for co-location with other system on adjacent frequencies for 30dB BS-BS minimum coupling loss. However, there are certain site-engineering solutions that can be used. These techniques are addressed in TR 25.942 [9].</p> <p>NOTE 2: The requirements in Table 6.17 are based on a minimum coupling loss of 30 dB between base stations. The co-location of different base station classes is not considered. A co-location requirement for the Local Area TDD BS is intended to be part of a later release.</p> <p>NOTE 3: The table above assumes that two operating bands, where the frequency ranges would be overlapping, are not deployed in the same geographical area. For such a case of operation with overlapping frequency arrangements in the same geographical area, special co-existence requirements may apply that are not covered by the 3GPP specifications.</p>				

The normative reference for this requirement is TS 25.105 [1] subclause 6.6.3.2.2.1.

6.6.3.2.3 (void)

6.6.3.2.3.1 (void)

Table 6.33: Void

Table 6.33a: Void

6.6.3.2.3.2 Void

Table 6.34: Void

Table 6.34a: Void

6.6.3.2.4 Void

6.6.3.2.4.1 Void

Table 6.35: Void

6.6.3.2.4.2 Void

Table 6.36: Void

6.6.3.2.5 Co-existence with unsynchronised UTRA TDD and/or E-UTRA TDD

6.6.3.2.5.1 Operation in the same geographic area

This requirement may be applied for the protection of TDD BS receivers in geographic areas in which unsynchronised UTRA TDD and/or E-UTRA TDD is deployed.

6.6.3.2.5.1.1 3,84 Mcps TDD option

The RRC filtered mean power of any spurious emission shall not exceed the maximum level given in table 6.36A.

Table 6.36A: BS Spurious emissions limits for operation in same geographic area with unsynchronised UTRA TDD and/or E-UTRA TDD

System type operating in the same geographic area	Frequency range	Maximum Level	Measurement Bandwidth
WA UTRA TDD Band a) or E-UTRA Band 33	1900 - 1920 MHz	-39 dBm	3,84 MHz
WA UTRA TDD Band a) or E-UTRA Band 34	2010 - 2025 MHz	-39 dBm	3,84 MHz
WA UTRA TDD Band d) or E-UTRA Band 38	2570 - 2620 MHz	-39 dBm	3,84 MHz
LA UTRA TDD Band a) or E-UTRA Band 33	1900 - 1920 MHz	-36 dBm	3,84 MHz
LA UTRA TDD Band a) or E-UTRA Band 34	2010 - 2025 MHz	-36 dBm	3,84 MHz
LA UTRA TDD Band d) or E-UTRA Band 38	2570 - 2620 MHz	-36 dBm	3,84 MHz

NOTE: The requirements in Table 6.36A for the Wide Area BS are based on a minimum coupling loss of 67 dB between unsynchronised TDD base stations. The requirements in Table 6.36A for the Local Area BS are based on a coupling loss of 70 dB between unsynchronised Wide Area and Local Area TDD base stations. The scenarios leading to these requirements are addressed in TR 25.942 [9].

The normative reference for this requirement is TS 25.105 [1] subclause 6.6.3.5.1.1.1.

6.6.3.2.5.1.2 1,28 Mcps TDD option

In geographic areas where only 1,28 Mcps TDD is deployed, the RRC filtered mean power of any spurious emission shall not exceed the maximum level given in table 6.36B, otherwise the limits in table 6.36C shall apply.

Table 6.36B: BS Spurious emissions limits for operation in same geographic area with unsynchronised 1,28 Mcps UTRA TDD and/or E-UTRA TDD

System type operating in the same geographic area	Frequency range	Maximum Level	Measurement Bandwidth
WA UTRA TDD Band a) or E-UTRA Band 33	1900 - 1920 MHz	-52 dBm	1 MHz
WA UTRA TDD Band a) or E-UTRA Band 34	2010 - 2025 MHz	-52 dBm	1 MHz
WA UTRA TDD Band d) or E-UTRA Band 38	2570 - 2620 MHz	-52 dBm	1 MHz
WA UTRA TDD Band e) or E-UTRA Band 40	2300 - 2400 MHz	-52 dBm	1 MHz
WA UTRA TDD Band f) or E-UTRA Band 39	1880 – 1920 MHz	-52 dBm	1 MHz
WA E-UTRA Band 41	2496 – 2690 MHz	-52 dBm	1 MHz
WA E-UTRA Band 42	3400 – 3600 MHz	-52 dBm	1 MHz
WA E-UTRA Band 44	703 – 803 MHz	-52 dBm	1 MHz
LA UTRA TDD Band a) or E-UTRA Band 33	1900 - 1920 MHz	-52 dBm	1 MHz
LA UTRA TDD Band a) or E-UTRA Band 34	2010 - 2025 MHz	-52 dBm	1 MHz
LA UTRA TDD Band d) or E-UTRA Band 38	2570 - 2620 MHz	-52 dBm	1 MHz
LA UTRA TDD Band e) or E-UTRA Band 40	2300 - 2400 MHz	-52 dBm	1 MHz
LA UTRA TDD Band f) or E-UTRA Band 39	1880 – 1920 MHz	-52 dBm	1 MHz
LA E-UTRA Band 41	2496 – 2690 MHz	-52 dBm	1 MHz
LA E-UTRA Band 42	3400 – 3600 MHz	-52 dBm	1 MHz
LA E-UTRA Band 44	703 – 803 MHz	-52 dBm	1 MHz

Table 6.36C: BS Spurious emissions limits for operation in same geographic area with unsynchronised UTRA TDD and E-UTRA TDD

Void

The normative reference for this requirement is TS 25.105 [1] subclause 6.6.3.5.1.1.2.

6.6.3.2.5.1.3 7,68 Mcps TDD option

The RRC filtered mean power of any spurious emission shall not exceed the maximum level given in table 6.36CA and 6.36CB.

Table 6.36CA: BS Spurious emissions limits for operation in same geographic area with unsynchronised UTRA TDD (7.68 Mcps TDD and 3,84 Mcps TDD) and/or E-UTRA TDD

System type operating in the same geographic area	Frequency range	Maximum Level	Measurement Bandwidth
WA UTRA TDD Band a) or E-UTRA Band 33	1900 - 1920 MHz	-39 dBm	3,84 MHz
WA UTRA TDD Band a) or E-UTRA Band 34	2010 - 2025 MHz	-39 dBm	3,84 MHz
WA UTRA TDD Band d) or E-UTRA Band 38	2570 - 2620 MHz	-39 dBm	3,84 MHz
LA UTRA TDD Band a) or E-UTRA Band 33	1900 - 1920 MHz	-36 dBm	3,84 MHz
LA UTRA TDD Band a) or E-UTRA Band 34	2010 - 2025 MHz	-36 dBm	3,84 MHz
LA UTRA TDD Band d) or E-UTRA Band 38	2570 - 2620 MHz	-36 dBm	3,84 MHz

Table 6.36CB: BS Spurious emissions limits for operation in same geographic area with unsynchronised 1,28 Mcps UTRA TDD and/or E-UTRA TDD

System type operating in the same geographic area	Frequency range	Maximum Level	Measurement Bandwidth
WA UTRA TDD Band a) or E-UTRA Band 33	1900 - 1920 MHz	-39 dBm	1,28 MHz
WA UTRA TDD Band a) or E-UTRA Band 34	2010 - 2025 MHz	-39 dBm	1,28 MHz
WA UTRA TDD Band d) or E-UTRA Band 38	2570 - 2620 MHz	-39 dBm	1,28 MHz
WA UTRA TDD Band e) or E-UTRA Band 40	2300 - 2400 MHz	-39 dBm	1,28 MHz
LA UTRA TDD Band a) or E-UTRA Band 33	1900 - 1920 MHz	-36 dBm	1,28 MHz
LA UTRA TDD Band a) or E-UTRA Band 34	2010 - 2025 MHz	-36 dBm	1,28 MHz
LA UTRA TDD Band d) or E-UTRA Band 38	2570 - 2620 MHz	-36 dBm	1,28 MHz
LA UTRA TDD Band e) or E-UTRA Band 40	2300 - 2400 MHz	-36 dBm	1,28 MHz

NOTE: The requirements in Table 6.36CA and 6.36CB for the Wide Area BS are based on a minimum coupling loss of 67 dB between unsynchronised TDD base stations. The requirements in Table 6.36CA and 6.36CB for the Local Area BS are based on a coupling loss of 70 dB between unsynchronised Wide Area and Local Area TDD base stations.

The normative reference for this requirement is TS 25.105 [1] subclause 6.6.3.5.1.1.3.

6.6.3.2.5.2 Co-located base stations

This requirement may be applied for the protection of TDD BS receivers when unsynchronised UTRA TDD and/or E-UTRA TDD BS are co-located.

6.6.3.2.5.2.1 3,84 Mcps TDD option

The RRC filtered mean power of any spurious emission shall not exceed the maximum level given in table 6.36D.

Table 6.36D: BS Spurious emissions limits for co-location with unsynchronised UTRA TDD and/or E-UTRA TDD

System type operating in the same geographic area	Frequency range	Maximum Level	Measurement Bandwidth
WA UTRA TDD Band a) or E-UTRA Band 33	1900 - 1920 MHz	-76 dBm	3,84 MHz
WA UTRA TDD Band a) or E-UTRA Band 34	2010 - 2025 MHz	-76 dBm	3,84 MHz
WA UTRA TDD Band d) or E-UTRA Band 38	2570 - 2620 MHz	-76 dBm	3,84 MHz
LA UTRA TDD Band a) or E-UTRA Band 33	1900 - 1920 MHz	-66 dBm	3,84 MHz
LA UTRA TDD Band a) or E-UTRA Band 34	2010 - 2025 MHz	-66 dBm	3,84 MHz
LA UTRA TDD Band d) or E-UTRA Band 38	2570 - 2620 MHz	-66 dBm	3,84 MHz

NOTE: The requirements in Table 6.36D for the Wide Area BS are based on a minimum coupling loss of 30 dB between unsynchronised TDD base stations. The requirements in Table 6.36D for the Local Area BS are based on a minimum coupling loss of 30 dB between unsynchronised Local Area base stations. The co-location of different base station classes is not considered.

The normative reference for this requirement is TS 25.105 [1] subclause 6.6.3.5.2.1.1.

6.6.3.2.5.2.2 1,28 Mcps TDD option

In geographic areas where only 1,28 Mcps TDD is deployed, the RRC filtered mean power of any spurious emission in case of co-location shall not exceed the maximum level given in table 6.36E, otherwise the limits in table 6.36F shall apply.

Table 6.36E: BS Spurious emissions limits for co-location with unsynchronised 1,28 Mcps UTRA TDD and/or E-UTRA TDD

System type operating in the same geographic area	Frequency range	Maximum Level	Measurement Bandwidth
WA UTRA TDD Band a) or E-UTRA Band 33	1900 - 1920 MHz	-96 dBm	100 kHz
WA UTRA TDD Band a) or E-UTRA Band 34	2010 - 2025 MHz	-96 dBm	100 kHz
WA UTRA TDD Band d) or E-UTRA Band 38	2570 - 2620 MHz	-96 dBm	100 kHz
WA UTRA TDD Band e) or E-UTRA Band 40	2300 - 2400 MHz	-96 dBm	100 kHz
WA UTRA TDD Band f) or E-UTRA Band 39	1880 - 1920 MHz	-96 dBm	100 kHz
WA E-UTRA Band 41	2496 – 2690 MHz	-96 dBm	100 kHz
WA E-UTRA Band 42	3400 – 3600 MHz	-96 dBm	100 kHz
WA E-UTRA Band 44	703 – 803 MHz	-96 dBm	100 kHz
LA UTRA TDD Band a) or E-UTRA Band 33	1900 - 1920 MHz	-88 dBm	100 kHz
LA UTRA TDD Band a) or E-UTRA Band 34	2010 - 2025 MHz	-88 dBm	100 kHz
LA UTRA TDD Band d) or E-UTRA Band 38	2570 - 2620 MHz	-88 dBm	100 kHz
LA UTRA TDD Band e) or E-UTRA Band 40	2300 - 2400 MHz	-88 dBm	100 kHz
LA UTRA TDD Band f) or E-UTRA Band 39	1880 - 1920 MHz	-88 dBm	100 kHz
LA E-UTRA Band 41	2496 – 2690 MHz	-88 dBm	100 kHz
LA E-UTRA Band 42	3400 – 3600 MHz	-88 dBm	100 kHz
LA E-UTRA Band 44	703 – 803 MHz	-88 dBm	100 kHz
NOTE: The requirement applies for frequencies more than 10 MHz below or above the supported frequency range declared by the vendor.			

Table 6.36F: BS Spurious emissions limits for co-location with unsynchronised UTRA TDD and/or E-UTRA TDD

Void

NOTE: The requirements in Table 6.36E and 6.36F for the Wide Area BS are based on a minimum coupling loss of 30 dB between unsynchronised TDD base stations. The requirements in Table 6.36E and 6.36F for the Local Area BS are based on a minimum coupling loss of 30 dB between unsynchronised Local Area base stations. The co-location of different base station classes is not considered.

The normative reference for this requirement is TS 25.105 [1] subclause 6.6.3.5.2.1.2.

6.6.3.2.5.2.3 7,68 Mcps TDD option

The RRC filtered mean power of any spurious emission shall not exceed the maximum level given in table 6.36G and 6.36H.

Table 6.36G: BS Spurious emissions limits for co-location with unsynchronised UTRA TDD (7,68 Mcps TDD and 3,84 Mcps TDD) and/or E-UTRA TDD

System type operating in the same geographic area	Frequency range	Maximum Level	Measurement Bandwidth
WA UTRA TDD Band a) or E-UTRA Band 33	1900 - 1920 MHz	-76 dBm	3,84 MHz
WA UTRA TDD Band a) or E-UTRA Band 34	2010 - 2025 MHz	-76 dBm	3,84 MHz
WA UTRA TDD Band d) or E-UTRA Band 38	2570 - 2620 MHz	-76 dBm	3,84 MHz
LA UTRA TDD Band a) or E-UTRA Band 33	1900 - 1920 MHz	-66 dBm	3,84 MHz
LA UTRA TDD Band a) or E-UTRA Band 34	2010 - 2025 MHz	-66 dBm	3,84 MHz
LA UTRA TDD Band d) or E-UTRA Band 38	2570 - 2620 MHz	-66 dBm	3,84 MHz

Table 6.36H: BS Spurious emissions limits for co-location with unsynchronised 1,28 Mcps UTRA TDD and/or E-UTRA TDD

System type operating in the same geographic area	Frequency range	Maximum Level	Measurement Bandwidth
WA UTRA TDD Band a) or E-UTRA Band 33	1900 - 1920 MHz	-76 dBm	1,28 MHz
WA UTRA TDD Band a) or E-UTRA Band 34	2010 - 2025 MHz	-76 dBm	1,28 MHz
WA UTRA TDD Band d) or E-UTRA Band 38	2570 - 2620 MHz	-76 dBm	1,28 MHz
WA UTRA TDD Band e) or E-UTRA Band 40	2300 - 2400 MHz	-76 dBm	1,28 MHz
LA UTRA TDD Band a) or E-UTRA Band 33	1900 - 1920 MHz	-71 dBm	1,28 MHz
LA UTRA TDD Band a) or E-UTRA Band 34	2010 - 2025 MHz	-71 dBm	1,28 MHz
LA UTRA TDD Band d) or E-UTRA Band 38	2570 - 2620 MHz	-71 dBm	1,28 MHz
LA UTRA TDD Band e) or E-UTRA Band 40	2300 - 2400 MHz	-71 dBm	1,28 MHz

NOTE: The requirements in Table 6.36G and 6.36H for the Wide Area BS are based on a minimum coupling loss of 30 dB between unsynchronised TDD base stations. The requirements in Table 6.36G and 6.36H for the Local Area BS are based on a minimum coupling loss of 30 dB between unsynchronised Local Area base stations. The co-location of different base station classes is not considered.

The normative reference for this requirement is TS 25.105 [1] subclause 6.6.3.5.2.1.3.

6.6.3.2.6 Co-existence with PHS

6.6.3.2.6.1 3,84 Mcps TDD option

This requirement may be applied for the protection of PHS in geographic areas in which both PHS and 3,84 Mcps UTRA TDD are deployed. For 3,84 Mcps TDD option, this requirement is also applicable at specified frequencies falling between 12.5MHz below the first carrier frequency used and 12.5MHz above the last carrier frequency used.

The power of any spurious emission shall not exceed the maximum level given in table 6.36I.

Table 6.36I: BS Spurious emissions limits for BS in geographic coverage area of PHS (3,84 Mcps TDD option)

Band	Maximum Level	Measurement Bandwidth	Note
1884.5 - 1915.7 MHz	-41 dBm	300 kHz	Applicable for transmission in 2010-2025 MHz as defined in subclause 4.2 (a).

6.6.3.2.6.2 (void)

6.6.3.2.6.3 7,68 Mcps TDD option

This requirement may be applied for the protection of PHS in geographic areas in which both PHS and 7,68 Mcps UTRA TDD are deployed. For 7,68 Mcps TDD option, this requirement is also applicable at specified frequencies falling between 25 MHz below the first carrier frequency used and 25MHz above the last carrier frequency used.

The power of any spurious emission shall not exceed the maximum level given in table 6.36J.

Table 6.36J: BS Spurious emissions limits for BS in geographic coverage area of PHS (7,68 Mcps TDD option)

Band	Maximum Level	Measurement Bandwidth	Note
1884.5 - 1915.7 MHz	-41 dBm	300 kHz	Applicable for transmission in 2010-2025 MHz as defined in subclause 4.2 (a).

6.6.3.3 Test purpose

6.6.3.3.1 3,84 Mcps TDD option

The test purpose is to verify the ability of the BS to limit the interference caused by unwanted transmitter effects to other systems operating at frequencies which are more than 12,5 MHz away from of the UTRA band used.

6.6.3.3.2 1,28 Mcps TDD option

The test purpose is to verify the ability of the BS to limit the interference caused by unwanted transmitter effects to other systems operating at frequencies which are more than 4 MHz away from of the UTRA band used.

6.6.3.3.3 7,68 Mcps TDD option

The test purpose is to verify the ability of the BS to limit the interference caused by unwanted transmitter effects to other systems operating at frequencies which are more than 25 MHz away from of the UTRA band used.

6.6.3.4 Method of test

6.6.3.4.1 Initial conditions

For 3,84 Mcps BS supporting 16QAM, the spurious requirements shall be tested with the general test set up specified in section 6.6.3.4.1.1 and also with the special test set up for 16QAM capable BS specified in section 6.6.3.4.1.4.

For 1,28 Mcps BS supporting 16QAM, the spurious requirements shall be tested with the general test set up specified in section 6.6.3.4.1.2 and also with the special test set up for 16QAM capable BS specified in section 6.6.3.4.1.3.

For 7,68 Mcps BS supporting 16QAM, the spurious requirements shall be tested with the general test set up specified in section 6.6.3.4.1.5 and also with the special test set up for 16QAM capable BS specified in section 6.6.3.4.1.6.

6.6.3.4.1.0 General test conditions

Test environment: normal; see subclause 5.9.1.

RF channels to be tested: B, M and T with multiple carriers if supported; see subclause 5.3.

6.6.3.4.1.1 3,84 Mcps TDD option - General test set up

- (1) Connect the measuring equipment to the antenna connector of the BS under test.
- (2) Set the parameters of the BS transmitted signal according to table 6.37. For MBSFN IMB operation the set of parameters for the transmitted signals is according to IMB test model 1 in subclause 6.1.1.1.

Table 6.37: Parameters of the BS transmitted signal for spurious emissions testing

Parameter	Value/description
TDD Duty Cycle	TS i ; $i = 0, 1, 2, \dots, 14$: transmit, if i is even; receive, if i is odd.
Time slot carrying SCH	TS0
Time slots under test	TS i , i even and non zero
BS output power setting	PRAT
Number of DPCH in each time slot under test	9
Power of each DPCH	1/9 of Base Station output power
Data content of DPCH	real life (sufficient irregular)

6.6.3.4.1.2 1,28 Mcps TDD option - General test set up

- (1) Connect the measuring equipment to the antenna connector of the BS under test.
- (2) Set the parameters of the BS transmitted signal according to table 6.37A.

Table 6.37A: Parameters of the BS transmitted signal for spurious emissions testing for 1,28 Mcps TDD

Parameter	Value/description
TDD Duty Cycle	TS i ; $i = 0, 1, 2, 3, 4, 5, 6$: transmit, if i is 0,4,5,6; receive, if i is 1,2,3.
Time slots under test	TS4, TS5 and TS6
BS output power setting	PRAT
Number of DPCH in each each time slot under test	8
Power of each DPCH	1/8 of Base Station output power
Data content of DPCH	real life (sufficient irregular)

6.6.3.4.1.3 1,28 Mcps TDD option - Special test set up for 16QAM capable BS

This test set up only applies for 16QAM capable BS.

- (1) Connect the measuring equipment to the antenna connector of the BS under test.
- (2) Set the parameters of the BS transmitted signal according to table 6.37B.

Table 6.37B: Parameters of the BS transmitted signal for spurious emissions testing for 1,28 Mcps TDD - 16QAM capable BS

Parameter	Value/description
TDD Duty Cycle	TS i ; $i = 0, 1, 2, 3, 4, 5, 6$: transmit, if i is 0,4,5,6; receive, if i is 1,2,3.
Time slots under test	TS4, TS5 and TS6
BS output power setting	PRAT
HS-PDSCH modulation	16QAM
Number of HS-PDSCH in each time slot under test	8
Power of each HS-PDSCH	1/8 of Base Station output power
Data content of HS-PDSCH	real life (sufficient irregular)
Spreading factor	16

6.6.3.4.1.4 3,84 Mcps TDD option - Special test set up for 16QAM capable BS

This test set up only applies for 16QAM capable BS.

- (1) Connect the measuring equipment to the antenna connector of the BS under test.
- (2) Set the parameters of the BS transmitted signal according to table 6.37C. For MBSFN IMB operation the set of parameters for the transmitted signals is according to IMB test model 2 in subclause 6.1.1.2.

Table 6.37C: Parameters of the BS transmitted signal for spurious emissions testing - 16QAM capable BS

Parameter	Value/description
TDD Duty Cycle	TS i ; $i = 0, 1, 2, \dots, 14$: transmit, if i is even; receive, if i is odd.
Time slot carrying SCH	TS0
Time slots under test	TS i , i even and non zero
BS output power setting	PRAT
HS-PDSCH modulation	16QAM
Number of HS-PDSCH in each time slot under test	9
Power of each HS-PDSCH	1/9 of Base Station output power
Data content of HS-PDSCH	real life (sufficient irregular)
Spreading factor	16

6.6.3.4.1.5 7,68 Mcps TDD option - General test set up

- (1) Connect the measuring equipment to the antenna connector of the BS under test.
- (2) Set the parameters of the BS transmitted signal according to table 6.37D.

Table 6.37D: Parameters of the BS transmitted signal for spurious emissions testing

Parameter	Value/description
TDD Duty Cycle	TS i ; $i = 0, 1, 2, \dots, 14$: transmit, if i is even; receive, if i is odd.
Time slot carrying SCH	TS0
Time slots under test	TS i , i even and non zero
BS output power setting	PRAT
Number of DPCH in each time slot under test	9
Power of each DPCH	1/9 of Base Station output power
Data content of DPCH	real life (sufficient irregular)

6.6.3.4.1.6 7,68 Mcps TDD option - Special test set up for 16QAM capable BS

This test set up only applies for 16QAM capable BS.

- (1) Connect the measuring equipment to the antenna connector of the BS under test.
- (2) Set the parameters of the BS transmitted signal according to table 6.37E.

Table 6.37E: Parameters of the BS transmitted signal for spurious emissions testing - 16QAM capable BS

Parameter	Value/description
TDD Duty Cycle	TS i ; $i = 0, 1, 2, \dots, 14$: transmit, if i is even; receive, if i is odd.
Time slot carrying SCH	TS0
Time slots under test	TS i , i even and non zero
BS output power setting	PRAT
HS-PDSCH modulation	16QAM
Number of HS-PDSCH in each time slot under test	9
Power of each HS-PDSCH	1/9 of Base Station output power
Data content of HS-PDSCH	real life (sufficient irregular)
Spreading factor	32

6.6.3.4.2 Procedure

Measure the power of the spurious emissions by applying measurement filters with bandwidths as specified in the relevant tables of subclause 6.6.3.2. The characteristics of the measurement filter with the bandwidth 1,28 MHz or 3,84MHz shall be RRC with roll-off $\alpha = 0,22$. The characteristics of the measurement filters with bandwidths 100 kHz and 1 MHz shall be approximately Gaussian (typical spectrum analyzer filter). The center frequency of the filter shall be stepped in contiguous steps over the frequency bands as given in the tables. The step width shall be equal to the respective measurement bandwidth. The time duration of each step shall be sufficiently long to capture one active time slot.

6.6.3.5 Test Requirements

NOTE: If the Test Requirement below differs from the Minimum Requirement, then the Test Tolerance applied for this test is non-zero. The Test Tolerance for this test is defined in subclause 5.11 and the explanation of how the Minimum Requirement has been relaxed by the Test Tolerance is given in Annex D.

The spurious emissions measured according to subclause 6.6.3.4.2 shall not exceed the limits specified in the relevant tables of 6.6.3.2.

For 3,84 Mcps TDD BS supporting 16QAM, the measured spurious emissions shall not exceed the limits specified for 3,84 Mcps TDD option in section 6.6.3.2.

For 1,28 Mcps TDD BS supporting 16QAM, the measured spurious emissions shall not exceed the limits specified for 1,28 Mcps TDD option in section 6.6.3.2.

For 7,68 Mcps TDD BS supporting 16QAM, the measured spurious emissions shall not exceed the limits specified for 7,68 Mcps TDD option in section 6.6.3.2.

6.7 Transmit intermodulation

6.7.1 Definition and applicability

The transmit intermodulation performance is a measure of the capability of the transmitter to inhibit the generation of signals in its non linear elements caused by presence of the wanted signal and an interfering signal reaching the transmitter via the antenna.

The transmit intermodulation level is the power of the intermodulation products when a CDMA modulated interference signal is injected into the antenna connector at a mean power level of 30 dB lower than that of the mean power of the subject signal.

The requirements are applicable for a single carrier.

The requirements in this subclause shall apply to both Wide Area BS and Local Area BS.

6.7.1.1 3,84 Mcps TDD option

The carrier frequency of the interference signal shall be ± 5 MHz, ± 10 MHz and ± 15 MHz offset from the subject signal carrier frequency, but excluding interference carrier frequencies outside of the UTRA frequency bands specified in 4.2a, 4.2b or 4.2c, respectively.

6.7.1.2 1,28 Mcps TDD option

The carrier frequency of the interference signal shall be $\pm 1,6$ MHz, $\pm 3,2$ MHz and $\pm 4,8$ MHz offset from the subject signal carrier frequency, but excluding interference carrier frequencies outside of the UTRA frequency bands specified in 4.2a, 4.2b or 4.2c, respectively.

6.7.1.3 7,68 Mcps TDD option

The carrier frequency of the interference signal shall be ± 10 MHz, ± 20 MHz and ± 30 MHz offset from the subject signal carrier frequency, but excluding interference carrier frequencies outside of the UTRA frequency bands specified in 4.2a, 4.2b or 4.2c, respectively.

6.7.2 Minimum Requirements

The transmit intermodulation level shall not exceed the out of band or the spurious emission requirements of subclause 6.6.2 and 6.6.3, respectively.

The normative reference for this requirement is TS 25.105 [1] subclause 6.7.1.

6.7.3 Test purpose

The test purpose is to verify the ability of the BS transmitter to restrict the generation of intermodulation products in its non linear elements caused by presence of the wanted signal and an interfering signal reaching the transmitter via the antenna to below specified levels.

6.7.4 Method of test

6.7.4.1 Initial conditions

For 3,84 Mcps BS supporting 16QAM, the transmit intermodulation requirements shall be tested with the general test set up specified in section 6.7.4.1.1 and also with the special test set up for 16QAM capable BS specified in section 6.7.4.1.4.

For 1,28 Mcps BS supporting 16QAM, the transmit intermodulation requirements shall be tested with the general test set up specified in section 6.7.4.1.2 and also with the special test set up for 16QAM capable BS specified in section 6.7.4.1.3.

For 7,68 Mcps BS supporting 16QAM, the transmit intermodulation requirements shall be tested with the general test set up specified in section 6.7.4.5.1 and also with the special test set up for 16QAM capable BS specified in section 6.7.4.1.6.

6.7.4.1.0 General test conditions

Test environment: normal; see subclause 5.9.1.

RF channels to be tested: B, M and T; see subclause 5.3.

6.7.4.1.1 3,84 Mcps TDD option - General test set up

- (1) Connect the measuring equipment, the BS under test and the WCDMA signal generator as shown in figure 6.2.
- (2) Set the parameters of the BS transmitted signal according to table 6.38. For MBSFN IMB operation the set of parameters for the transmitted signals is according to IMB test model 1 in subclause 6.1.1.1.
- (3) Configure the WCDMA signal generator to produce an interference signal with a mean power level according to subclause 6.7.5. The interference signal shall be like-modulated as the BS transmitted signal, and the active time slots of both signals shall be synchronized. The carrier frequency of the interference signal shall be ± 5 MHz, ± 10 MHz and ± 15 MHz offset from the carrier frequency of the wanted signal, but excluding interference frequencies outside of the UTRA frequency bands specified in 4.2a, 4.2b or 4.2c, respectively.

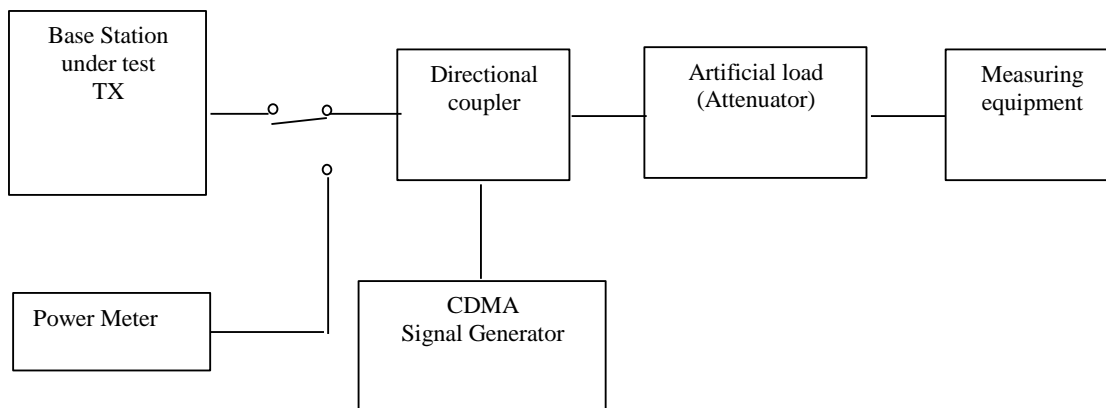

Figure 6.2: Measuring setup for Base Station transmit intermodulation testing

Table 6.38: Parameters of the BS transmitted signal for transmit intermodulation testing

Parameter	Value/description
TDD Duty Cycle	TS i ; $i = 0, 1, 2, \dots, 14$: transmit, if i is odd; receive, if i is even.
Time slot carrying SCH	TS0
Time slots under test	TS i , i even and non zero
BS output power setting	PRAT
Number of DPCH in each time slot under test	9
Power of each DPCH	1/9 of Base Station output power
Data content of DPCH	real life (sufficient irregular)

6.7.4.1.2 1,28 Mcps TDD option - General test set up

- (1) Connect the measuring equipment, the BS under test and the 1,28 Mcps TDD signal generator as shown in figure 6.2A.
- (2) Set the parameters of the BS transmitted signal according to table 6.38A.
- (3) Configure the 1,28 Mcps TDD signal generator to produce an interference signal with a mean power level according to subclause 6.7.5. The interference signal shall be like-modulated as the BS transmitted signal, and the active time slots of both signals shall be synchronized. The carrier frequency of the interference signal shall be $\pm 1,6$ MHz, $\pm 3,2$ MHz and $\pm 4,8$ MHz offset from the carrier frequency of the wanted signal, but excluding interference frequencies outside of the UTRA frequency bands specified in 4.2a, 4.2b or 4.2c, respectively.

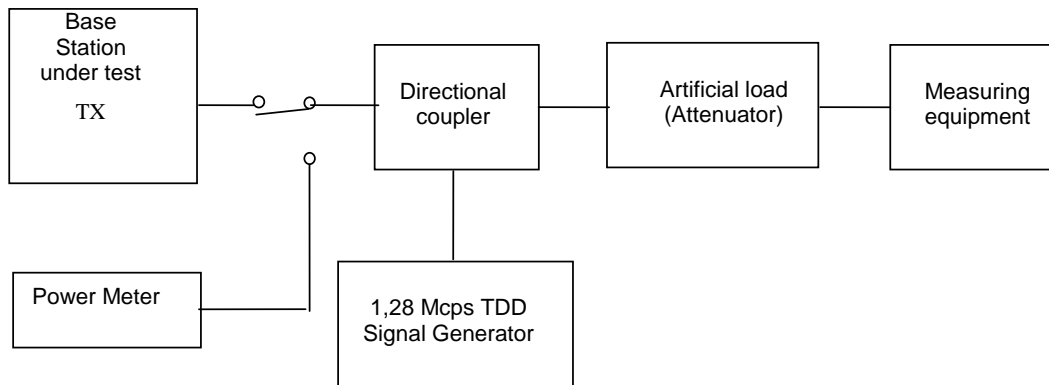

Figure 6.2A: Measuring set up for Base Station transmit intermodulation testing

Table 6.38A: Parameters of the BS transmitted signal for transmit intermodulation testing for 1,28 Mcps TDD

Parameter	Value/description
TDD Duty Cycle	TS i ; $i = 0, 1, 2, 3, 4, 5, 6$: transmit, if i is 0,4,5,6; receive, if i is 1,2,3.
Time slots under test	TS4, TS5 and TS6
BS output power setting	PRAT
Number of DPCH in each time slot under test	8
Power of each DPCH	1/8 of Base Station output power
Data content of DPCH	real life (sufficient irregular)

6.7.4.1.3 1,28 Mcps TDD option - Special test set up for 16QAM capable BS

This test set up only applies for 16QAM capable BS.

- (1) Connect the measuring equipment, the BS under test and the 1,28 Mcps TDD signal generator as shown in figure 6.2B.
- (2) Set the parameters of the BS transmitted signal according to table 6.38B.
- (3) Configure the 1,28 Mcps TDD signal generator to produce an interference signal with a mean power level according to subclause 6.7.5. The interference signal shall be like-modulated as the BS transmitted signal, and the active time slots of both signals shall be synchronized. The carrier frequency of the interference signal shall be $\pm 1,6$ MHz, $\pm 3,2$ MHz and $\pm 4,8$ MHz offset from the carrier frequency of the wanted signal, but excluding interference frequencies outside of the UTRA frequency bands specified in 4.2a, 4.2b or 4.2c, respectively.

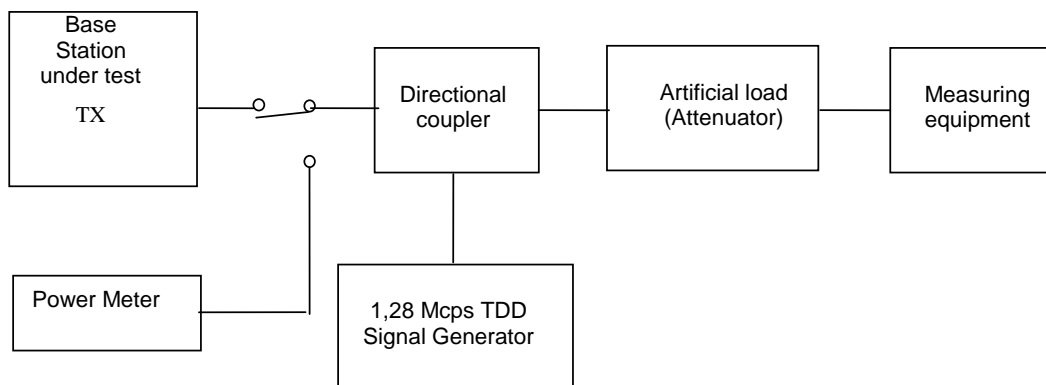

Figure 6.2B: Measuring setup for Base Station transmit intermodulation testing

Table 6.38B: Parameters of the BS transmitted signal for transmit intermodulation testing for 1,28 Mcps TDD- 16QAM capable BS

Parameter	Value/description
TDD Duty Cycle	TS i ; $i = 0, 1, 2, 3, 4, 5, 6$: transmit, if i is 0,4,5,6; receive, if i is 1,2,3.
Time slots under test	TS4, TS5 and TS6
BS output power setting	PRAT
HS-PDSCH modulation	16QAM
Number of HS-PDSCH in each time slot under test	8
Power of each HS-PDSCH	1/8 of Base Station output power
Data content of HS-PDSCH	real life (sufficient irregular)
Spreading factor	16

6.7.4.1.4 3,84 Mcps TDD option - Special test set up for 16QAM capable BS

- (1) Connect the measuring equipment, the BS under test and the WCDMA signal generator as shown in figure 6.3.
- (2) Set the parameters of the BS transmitted signal according to table 6.38C. For MBSFN IMB operation the set of parameters for the transmitted signals is according to IMB test model 2 in subclause 6.1.1.2.
- (3) Configure the WCDMA signal generator to produce an interference signal with a mean power level according to subclause 6.7.5. The interference signal shall be like-modulated as the BS transmitted signal, and the active time slots of both signals shall be synchronized. The carrier frequency of the interference signal shall be ± 5 MHz, ± 10 MHz and ± 15 MHz offset from the carrier frequency of the wanted signal, but excluding interference frequencies outside of the UTRA frequency bands specified in 4.2a, 4.2b or 4.2c, respectively.

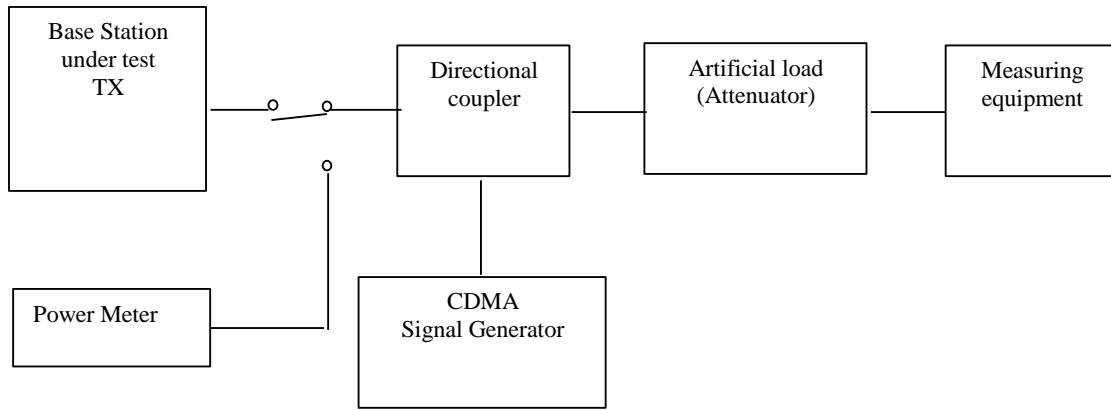

Figure 6.3: Measuring setup for Base Station transmit intermodulation testing

Table 6.38C: Parameters of the BS transmitted signal for transmit intermodulation testing - 16QAM capable BS

Parameter	Value/description
TDD Duty Cycle	TS i ; $i = 0, 1, 2, \dots, 14$: transmit, if i is even; receive, if i is odd.
Time slot carrying SCH	TS0
Time slots under test	TS i , i even and non zero
BS output power setting	PRAT
HS-PDSCH modulation	16QAM
Number of HS-PDSCH in each time slot under test	9
Power of each HS-PDSCH	1/9 of Base Station output power
Data content of HS-PDSCH	real life (sufficient irregular)
Spreading factor	16

6.7.4.1.5 7,68 Mcps TDD option - General test set up

- (1) Connect the measuring equipment, the BS under test and the WCDMA signal generator as shown in figure 6.4.
- (2) Set the parameters of the BS transmitted signal according to table 6.38D.
- (3) Configure the WCDMA signal generator to produce an interference signal with a mean power level according to subclause 6.7.5. The interference signal shall be like-modulated as the BS transmitted signal, and the active time slots of both signals shall be synchronized. The carrier frequency of the interference signal shall be ± 10 MHz, ± 20 MHz and ± 30 MHz offset from the carrier frequency of the wanted signal, but excluding interference frequencies outside of the UTRA frequency bands specified in 4.2a, 4.2b or 4.2c, respectively.

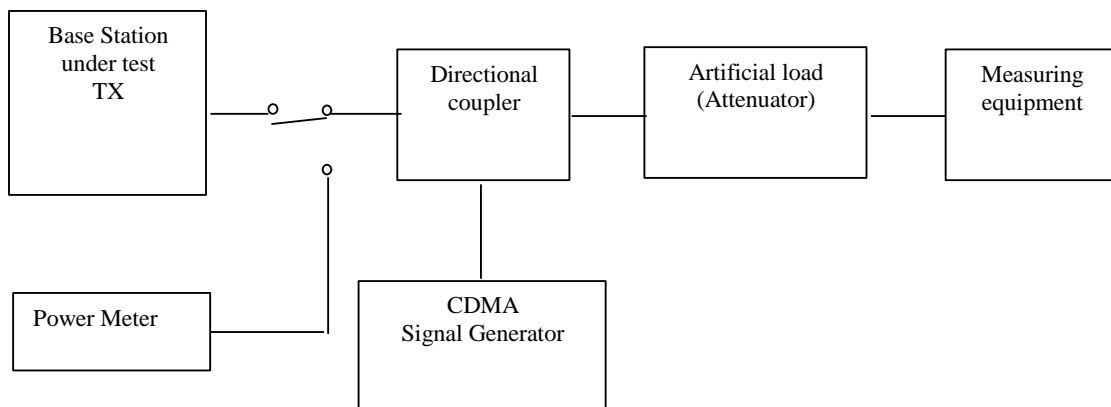

Figure 6.4: Measuring setup for Base Station transmit intermodulation testing

Table 6.38D: Parameters of the BS transmitted signal for transmit intermodulation testing

Parameter	Value/description
TDD Duty Cycle	TS i ; $i = 0, 1, 2, \dots, 14$: transmit, if i is odd; receive, if i is even.
Time slot carrying SCH	TS0
Time slots under test	TS i , i even and non zero
BS output power setting	PRAT
Number of DPCH in each time slot under test	9
Power of each DPCH	1/9 of Base Station output power
Data content of DPCH	real life (sufficient irregular)

6.7.4.1.6 7,68 Mcps TDD option - Special test set up for 16QAM capable BS

- (1) Connect the measuring equipment, the BS under test and the WCDMA signal generator as shown in figure 6.5.
- (2) Set the parameters of the BS transmitted signal according to table 6.38D.
- (3) Configure the WCDMA signal generator to produce an interference signal with a mean power level according to subclause 6.7.5. The interference signal shall be like-modulated as the BS transmitted signal, and the active time slots of both signals shall be synchronized. The carrier frequency of the interference signal shall be ± 10 MHz, ± 20 MHz and ± 30 MHz offset from the carrier frequency of the wanted signal, but excluding interference frequencies outside of the UTRA frequency bands specified in 4.2a, 4.2b or 4.2c, respectively.

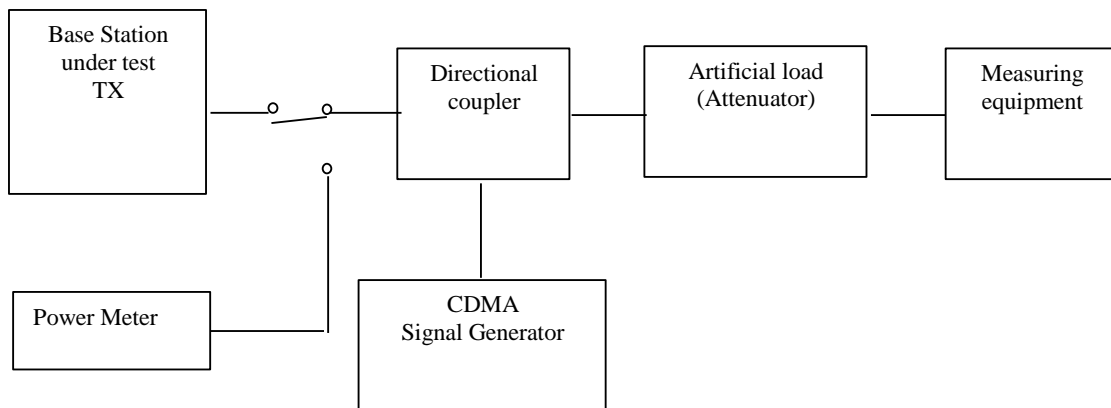
**Figure 6.5: Measuring setup for Base Station transmit intermodulation testing****Table 6.38D: Parameters of the BS transmitted signal for transmit intermodulation testing - 16QAM capable BS**

Parameter	Value/description
TDD Duty Cycle	TS i ; $i = 0, 1, 2, \dots, 14$: transmit, if i is even; receive, if i is odd.
Time slot carrying SCH	TS0
Time slots under test	TS i , i even and non zero
BS output power setting	PRAT
HS-PDSCH modulation	16QAM
Number of HS-PDSCH in each time slot under test	9
Power of each HS-PDSCH	1/9 of Base Station output power
Data content of HS-PDSCH	real life (sufficient irregular)
Spreading factor	32

6.7.4.2 Procedure

Apply the test procedures for out of band and spurious emissions as described in 6.6.2 and 6.6.3, respectively, at the frequencies of all third and fifth order intermodulation products. The frequency band occupied by the interference signal are excluded from the measurements.

NOTE: The third order intermodulation products are at frequencies $(F1 \pm 2F2)$ and $(2F1 \pm F2)$, the fifth order intermodulation products are at frequencies $(2F1 \pm 3F2)$, $(3F1 \pm 2F2)$, $(4F1 \pm F2)$ and $(F1 \pm 4F2)$, where $F1$ represents the frequencies within the bandwidth of the wanted signal and $F2$ represents the frequencies within the bandwidth of the CDMA modulated interference signal.

6.7.5 Test Requirements

NOTE: If the Test Requirement below differs from the Minimum Requirement, then the Test Tolerance applied for this test is non-zero. The Test Tolerance for this test is defined in subclause 5.1.1 and the explanation of how the Minimum Requirement has been relaxed by the Test Tolerance is given in Annex D.

The mean power level of the CDMA modulated interference signal shall be 30 dB below the mean power level of the wanted signal.

At the frequencies of all third and fifth order intermodulation products, the Test Requirements for out of band and spurious emissions as specified in subclauses 6.6.2.1.5 (Spectrum emission mask), 6.6.2.2.5 (ACLR) and 6.6.3.5 (Spurious emissions) shall be met.

6.8 Transmit Modulation

6.8.1 Modulation accuracy

6.8.1.1 Definition and applicability

The Error Vector Magnitude is a measure of the difference between the reference waveform and the measured waveform. This difference is called the error vector. Both waveforms pass through a matched Root Raised Cosine filter with bandwidth corresponding to the considered chip rate and roll-off $\alpha = 0,22$. Both waveforms are then further modified by selecting the frequency, absolute phase, absolute amplitude and chip clock timing so as to minimise the error vector. The EVM result is defined as the square root of the ratio of the mean error vector power to the mean reference power expressed as a %. The measurement interval is one timeslot. The requirement is valid over the total power dynamic range as specified in section 3.1. See Annex C of this specification for further details.

The requirements in this subclause shall apply to both Wide Area BS and Local Area BS.

NOTE: The theoretical modulated waveform shall be calculated on the basis that the transmit pulse shaping filter is a root-raised cosine (RRC) with roll-off $\alpha = 0,22$ in the frequency domain. The impulse response of the chip impulse filter $RC_0(t)$ is

$$RC_0(t) = \frac{\sin\left(\pi \frac{t}{T_c}(1-\alpha)\right) + 4\alpha \frac{t}{T_c} \cos\left(\pi \frac{t}{T_c}(1+\alpha)\right)}{\pi \frac{t}{T_c} \left(1 - \left(4\alpha \frac{t}{T_c}\right)^2\right)}$$

Where the roll-off factor $\alpha = 0,22$ and T_c is the chip duration

6.8.1.2 Minimum Requirements

The error vector magnitude (EVM) shall not exceed 12,5 %. The requirement is valid over the total power dynamic range as specified in section 3.1.

The normative reference for this requirement is TS 25.105 [1] subclause 6.8.2.1.

6.8.1.3 Test purpose

The test purpose is to verify the ability of the BS transmitter to generate a sufficient precise waveform and thus to enable the UE receiver to achieve the specified error performance.

6.8.1.4 Method of test

6.8.1.4.1 Initial conditions

For 1,28 Mcps BS supporting 16QAM, the EVM requirements shall be tested with the general test set up specified in section 6.8.1.4.1.2 and also with the special test set up for 16QAM capable base station specified in section 6.8.1.4.1.2.

6.8.1.4.1.0 General test conditions

Test environment: normal; see subclause 5.9.1.

RF channels to be tested: B, M and T; see subclause 5.3.

6.8.1.4.1.1 3,84 Mcps TDD option - General test setup

- (1) Connect the measuring equipment to the antenna connector of the BS under test.
- (2) Set the parameters of the BS transmitted signal according to table 6.39. For MBSFN IMB operation the set of parameters for the transmitted signals is according to IMB test model 1 in subclause 6.1.1.1.

Table 6.39: Parameters of the BS transmitted signal for modulation accuracy testing

Parameter	Value/description
TDD Duty Cycle	TS i ; $i = 0, 1, 2, \dots, 14$: transmit, if i is even; receive, if i is odd.
Time slot carrying SCH	TS0
Time slots under test	TS i , i even and non zero
Number of DPCH in each time slot under test	1
Power of each DPCH	1/9 of Base Station output power
BS power setting	PRAT
Data content of DPCH	real life (sufficient irregular)

6.8.1.4.1.2 1,28 Mcps TDD option - General test set up

- (1) Connect the measuring equipment to the antenna connector of the BS under test.
- (2) Set the parameters of the BS transmitted signal according to table 6.39A.

Table 6.39A: Parameters of the BS transmitted signal for modulation accuracy testing at maximum BS output power for 1,28 Mcps TDD

Parameter	Value/description
TDD Duty Cycle	TS i ; $i = 0, 1, 2, \dots, 6$: Transmit, if i is 0,4,5,6; receive, if i is 1,2,3.
Time slots under test	TS4, TS5 and TS6
Number of DPCH in each time slot under test	10
Power of each DPCH	1/10 of Base Station output power
Base station power	PRAT
Data content of DPCH	real life (sufficient irregular)

6.8.1.4.1.3 1,28 Mcps TDD option - Special test set up for 16QAM capable BS

This test set up only applies for 16QAM capable BS.

- (1) Connect the measuring equipment to the antenna connector of the BS under test.
- (2) Set the parameters of the BS transmitted signal according to table 6.39B.

Table 6.39B: Parameters of the BS transmitted signal for modulation accuracy testing at maximum BS output power setting for 1,28 Mcps TDD - 16QAM capable BS

Parameter	Value/description
TDD Duty Cycle	TS i ; $i = 0, 1, 2, 3, 4, 5, 6$: transmit, if i is 0,4,5,6; receive, if i is 1,2,3.
Time slots under test	TS4, TS5 and TS6
HS-PDSCH modulation	16QAM
Number of HS-PDSCH in each time slot under test	10
Power of each HS-PDSCH	1/10 of Base Station output power
BS station power	PRAT
Data content of HS-PDSCH	Real life (sufficient irregular)
Spreading factor	16

6.8.1.4.1.4 3,84 Mcps TDD option - Special test set up for 16QAM capable BS

This test set up only applies for 16QAM capable BS.

- (1) Connect the measuring equipment to the antenna connector of the BS under test.
- (2) Set the parameters of the BS transmitted signal according to table 6.39BA. For MBSFN IMB operation the set of parameters for the transmitted signals is according to IMB test model 2 in subclause 6.1.1.2.

Table 6.39BA: Parameters of the BS transmitted signal for modulation accuracy testing at maximum BS output power setting for 3,84 Mcps TDD - 16QAM capable BS

Parameter	Value/description
TDD Duty Cycle	TS i ; $i = 0, 1, 2, \dots, 14$: transmit, if i is even; receive, if i is odd.
Time slots under test	TS i , i even and non zero
HS-PDSCH modulation	16QAM
Number of DPCH in each time slot under test	9
Power of each DPCH	1/9 of Base Station output power
BS power setting	PRAT
Data content of DPCH	real life (sufficient irregular)
Spreading factor	16

6.8.1.4.1.5 7,68 Mcps TDD option - General test setup

- (1) Connect the measuring equipment to the antenna connector of the BS under test.
- (2) Set the parameters of the BS transmitted signal according to table 6.39BC.

Table 6.39BC: Parameters of the BS transmitted signal for modulation accuracy testing

Parameter	Value/description
TDD Duty Cycle	TS i ; $i = 0, 1, 2, \dots, 14$: transmit, if i is even; receive, if i is odd.
Time slot carrying SCH	TS0
Time slots under test	TS i , i even and non zero
Number of DPCH in each time slot under test	1
Power of each DPCH	1/9 of Base Station output power
BS power setting	PRAT
Data content of DPCH	real life (sufficient irregular)

6.8.1.4.1.6 7,68 Mcps TDD option - Special test set up for 16QAM capable BS

This test set up only applies for 16QAM capable BS.

- (1) Connect the measuring equipment to the antenna connector of the BS under test.
- (2) Set the parameters of the BS transmitted signal according to table 6.39BD.

Table 6.39BD: Parameters of the BS transmitted signal for modulation accuracy testing at maximum BS output power setting for 7.68 Mcps TDD - 16QAM capable BS

Parameter	Value/description
TDD Duty Cycle	TS i ; $i = 0, 1, 2, \dots, 14$: transmit, if i is even; receive, if i is odd.
Time slots under test	TS i , i even and non zero
HS-PDSCH modulation	16QAM
Number of DPCH in each time slot under test	9
Power of each DPCH	1/9 of Base Station output power
BS power setting	PRAT
Data content of DPCH	real life (sufficient irregular)
Spreading factor	32

6.8.1.4.2 Procedure

6.8.1.4.2.1 3,84 Mcps TDD option - General procedure

- (1) Measure the error vector magnitude (EVM) by applying the global in-channel Tx test method described in Annex C with the BS transmitted signal set as described in Table 6.39.
- (2) Set the BS transmitted signal according to Table 6.39BB and measure the error vector magnitude (EVM) by applying the global in-channel Tx test method described in Annex C. For MBSFN IMB operation the set of parameters for the transmitted signals is according to IMB test model 1 in subclause 6.1.1.1. A prerequisite for the test is that the BS output power setting is set to the maximum – 30 dB.

Table 6.39BB: Parameters of the BS transmitted signal for modulation accuracy testing at minimum BS output power setting for 3,84 Mcps TDD

Parameter	Value/description
TDD Duty Cycle	TS i ; $i = 0, 1, 2, \dots, 14$: transmit, if i is even; receive, if i is odd.
Time slot carrying SCH	TS0
Time slots under test	TS i , i even and non zero
BS output power setting	Maximum output power - 30 dB
Number of DPCH in each time slot under test	1
Data content of DPCH	real life (sufficient irregular)

6.8.1.4.2.2 1,28 Mcps TDD option - General procedure

- (1) Measure the error vector magnitude (EVM) by applying the global in-channel Tx test method described in Annex C with the BS transmitted signal set as described in Table 6.39A.
- (2) Set the BS transmitted signal according Table 6.39C and measure the error vector magnitude (EVM) by applying the global in-channel Tx test method described in Annex C.

Table 6.39C: Parameters of the BS transmitted signal for modulation accuracy testing at minimum BS output power for 1,28 Mcps TDD

Parameter	Value/description
TDD Duty Cycle	TS i ; $i = 0, 1, 2, \dots, 6$: Transmit, if i is 0,4,5,6; receive, if i is 1,2,3.
Time slot under test	TS4, TS5 and TS6
Number of DPCH in each time slot under test	1
BS output power setting	Maximum output power - 30 dB
Data content of DPCH	Real life (sufficient irregular)

6.8.1.4.2.3 1,28 Mcps TDD option - Special procedure for 16QAM capable BS

- (1) Measure the error vector magnitude (EVM) by applying the global in-channel Tx test method described in Annex C with the BS transmitted signal set as described in Table 6.39B.
- (2) Set the BS transmitted signal according Table 6.39D and measure the error vector magnitude (EVM) by applying the global in-channel Tx test method described in Annex C.

Table 6.39D: Parameters of the BS transmitted signal for modulation accuracy testing at minimum BS output power setting for 1,28 Mcps TDD - 16QAM capable BS

Parameter	Value/description
TDD Duty Cycle	TS i ; $i = 0, 1, 2, 3, 4, 5, 6$: transmit, if i is 0,4,5,6; receive, if i is 1,2,3.
HS-PDSCH modulation	16QAM
Time slots under test	TS4, TS5 and TS6
Number of HS-PDSCH in each time slot under test	1
BS output power setting	Maximum output power - 30 dB
Data content of HS-PDSCH	Real life (sufficient irregular)
Spreading factor	16

6.8.1.4.2.4 3,84 Mcps TDD option - Special test set up for 16QAM capable BS

This test set up only applies for 16QAM capable BS.

- (1) Measure the error vector magnitude (EVM) by applying the global in-channel Tx test method described in Annex C.
- (2) Set the BS transmitted signal according Table 6.39E and measure the error vector magnitude (EVM) by applying the global in-channel Tx test method described in Annex C. For MBSFN IMB operation the set of parameters for the transmitted signals is according to IMB test model 2 in subclause 6.1.1.2. A prerequisite for the test is that the BS output power setting is set to the maximum – 30 dB.

Table 6.39E: Parameters of the BS transmitted signal for modulation accuracy testing at minimum BS output power setting for 3,84 Mcps TDD - 16QAM capable BS

Parameter	Value/description
TDD Duty Cycle	TS i ; $i = 0, 1, 2, \dots, 14$: transmit, if i is even; receive, if i is odd.
Time slot carrying SCH	TS0
Time slots under test	TS i , i even and non zero
BS output power setting	Maximum output power- 30 dB
HS-PDSCH modulation	16QAM
Number of HS-PDSCH in each time slot under test	1
Data content of HS-PDSCH	real life (sufficient irregular)
Spreading factor	16

6.8.1.4.2.5 7,68 Mcps TDD option - General procedure

- (1) Measure the error vector magnitude (EVM) by applying the global in-channel Tx test method described in Annex C with the BS transmitted signal set as described in Table 6.39F.
- (2) Set the BS transmitted signal according to Table 6.39F and measure the error vector magnitude (EVM) by applying the global in-channel Tx test method described in Annex C

Table 6.39F: Parameters of the BS transmitted signal for modulation accuracy testing at minimum BS output power setting for 7,68 Mcps TDD

Parameter	Value/description
TDD Duty Cycle	TS i ; $i = 0, 1, 2, \dots, 14$: transmit, if i is even; receive, if i is odd.
Time slot carrying SCH	TS0
Time slots under test	TS i , i even and non zero
BS output power setting	Maximum output power - 30 dB
Number of DPCH in each time slot under test	1
Data content of DPCH	real life (sufficient irregular)

6.8.1.4.2.6 7,68 Mcps TDD option - Special test set up for 16QAM capable BS

This test set up only applies for 16QAM capable BS.

- (1) Measure the error vector magnitude (EVM) by applying the global in-channel Tx test method described in Annex C.
- (2) Set the BS transmitted signal according Table 6.39G and measure the error vector magnitude (EVM) by applying the global in-channel Tx test method described in Annex C.

Table 6.39G: Parameters of the BS transmitted signal for modulation accuracy testing at minimum BS output power setting for 7,68 Mcps TDD - 16QAM capable BS

Parameter	Value/description
TDD Duty Cycle	TS i ; $i = 0, 1, 2, \dots, 14$: transmit, if i is even; receive, if i is odd.
Time slot carrying SCH	TS0
Time slots under test	TS i , i even and non zero
BS output power setting	Maximum output power- 30 dB
HS-PDSCH modulation	16QAM
Number of HS-PDSCH in each time slot under test	1
Data content of HS-PDSCH	real life (sufficient irregular)
Spreading factor	32

6.8.1.5 Test Requirements

NOTE: If the Test Requirement below differs from the Minimum Requirement, then the Test Tolerance applied for this test is non-zero. The Test Tolerance for this test is defined in subclause 5.1.1 and the explanation of how the Minimum Requirement has been relaxed by the Test Tolerance is given in Annex D.

The error vector magnitude (EVM) measured according to subclause 6.8.1.4.2 shall not exceed 12,5 %.

6.8.2 Peak code domain error

6.8.2.1 Definition and applicability

The code domain error is computed by projecting the error vector power onto the code domain at a specific spreading factor. The error power for each code is defined as the ratio to the mean power of the reference waveform expressed in dB. And the Peak Code Domain Error is defined as the maximum value for Code Domain Error. The measurement interval is one timeslot.

The requirements in this subclause shall apply to both Wide Area BS and Local Area BS.

6.8.2.2 Minimum Requirements

The peak code domain error shall not exceed -28 dB at spreading factor 16. For 7.68 Mcps, the peak code domain error shall not exceed -31 dB at spreading factor 32.

The normative reference for this requirement is TS 25.105 [1] subclause 6.8.3.1.

6.8.2.3 Test purpose

The test purpose is to verify the ability of the BS transmitter to limit crosstalk among codes and thus to enable the UE receiver to achieve the specified error performance.

6.8.2.4 Method of test

6.8.2.4.1 Initial conditions

For 3,84 Mcps BS supporting 16QAM, the PCDE requirement shall be tested with the general test set up specified in section 6.8.2.4.1 and also with the special test set up for 16QAM capable BS specified in section 6.8.2.4.4.

For 1,28 Mcps BS supporting 16QAM, the PCDE requirement shall be tested with the general test set up specified in section 6.8.2.4.2 and also with the special test set up for 16QAM capable BS specified in section 6.8.2.4.3.

For 7,68 Mcps BS supporting 16QAM, the PCDE requirement shall be tested with the general test set up specified in section 6.8.2.4.1.5 and also with the special test set up for 16QAM capable BS specified in section 6.8.2.4.1.6.

6.8.2.4.1.0 General test conditions

Test environment: normal; see subclause 5.9.1.

RF channels to be tested: B, M and T; see subclause 5.3.

6.8.2.4.1.1 3,84 Mcps TDD option - General test set up

- (1) Connect the measuring equipment to the antenna connector of the BS under test.
- (2) Set the parameters of the BS transmitted signal according to table 6.40. For MBSFN IMB operation the set of parameters for the transmitted signals is according to IMB test model 1 in subclause 6.1.1.1.

Table 6.40: Parameters of the BS transmitted signal

Parameter	Value/description
TDD Duty Cycle	TS i ; $i = 0, 1, 2, \dots, 14$: transmit, if i is even; receive, if i is odd.
Time slot carrying SCH	TS0
Time slots under test	TS i , i even and non zero
BS output power setting	PRAT
Number of DPCH in each time slot under test	9
Power of each DPCH	1/9 of Base Station output power
Data content of DPCH	real life (sufficient irregular)
Spreading factor	16

6.8.2.4.1.2 1,28 Mcps TDD option- General test set up

- (1) Connect the measuring equipment to the antenna connector of the BS under test.
- (2) Set the parameters of the BS transmitted signal according to table 6.40A.

Table 6.40A: Parameters of the BS transmitted signal for 1,28 Mcps TDD

Parameter	Value/description
TDD Duty Cycle	TS i ; $i = 0, 1, 2, \dots, 6$: transmit, if i is 0,4,5,6; receive, if i is 1,2,3.
Time slots under test	TS4, TS5 and TS6
BS output power setting	PRAT
Number of DPCH in each time slot under test	10
Power of each DPCH	1/10 of Base Station output power
Data content of DPCH	real life (sufficient irregular)
Spreading factor	16

6.8.2.4.1.3 1,28 Mcps TDD option - Special test set up for 16QAM capable BS

This test set up only applies for 16QAM capable BS.

- (1) Connect the measuring equipment to the antenna connector of the BS under test.
- (2) Set the parameters of the BS transmitted signal according to table 6.40B.

Table 6.40B: Parameters of the BS transmitted signal for 1,28 Mcps TDD - 16QAM capable BS

Parameter	Value/description
TDD Duty Cycle	TS i ; $i = 0, 1, 2, \dots, 6$: transmit, if i is 0,4,5,6; receive, if i is 1,2,3.
Time slots under test	TS4, TS5 and TS6
HS-PDSCH modulation	16QAM
BS output power setting	PRAT
Number of HS-PDSCH in each time slot under test	10
Power of each HS-PDSCH	1/10 of Base Station output power
Data content of HS-DSCH	real life (sufficient irregular)
Spreading factor	16

6.8.2.4.1.4 3,84 Mcps TDD option - Special test set up for 16QAM capable BS

This test set up only applies for 16QAM capable BS.

- (1) Connect the measuring equipment to the antenna connector of the BS under test.
- (2) Set the parameters of the BS transmitted signal according to table 6.40C. For MBSFN IMB operation the set of parameters for the transmitted signals is according to IMB test model 2 in subclause 6.1.1.2.

Table 6.40C: Parameters of the BS transmitted signal - 16QAM capable BS

Parameter	Value/description
TDD Duty Cycle	TS i ; $i = 0, 1, 2, \dots, 14$: transmit, if i is even; receive, if i is odd.
Time slot carrying SCH	TS0
Time slots under test	TS i , i even and non zero
BS output power setting	PRAT
HS-PDSCH modulation	16QAM
Number of HS-PDSCH in each time slot under test	9
Power of each HS-PDSCH	1/9 of Base Station output power
Data content of HS-PDSCH	real life (sufficient irregular)
Spreading factor	16

6.8.2.4.1.5 7,68 Mcps TDD option - General test set up

- (1) Connect the measuring equipment to the antenna connector of the BS under test.
- (2) Set the parameters of the BS transmitted signal according to table 6.40D.

Table 6.40D: Parameters of the BS transmitted signal

Parameter	Value/description
TDD Duty Cycle	TS i ; $i = 0, 1, 2, \dots, 14$: transmit, if i is even; receive, if i is odd.
Time slot carrying SCH	TS0
Time slots under test	TS i , i even and non zero
BS output power setting	PRAT
Number of DPCH in each time slot under test	9
Power of each DPCH	1/9 of Base Station output power
Data content of DPCH	real life (sufficient irregular)
Spreading factor	32

6.8.2.4.1.6 7,68 Mcps TDD option - Special test set up for 16QAM capable BS

This test set up only applies for 16QAM capable BS.

- (1) Connect the measuring equipment to the antenna connector of the BS under test.
- (2) Set the parameters of the BS transmitted signal according to table 6.40E.

Table 6.40E: Parameters of the BS transmitted signal - 16QAM capable BS

Parameter	Value/description
TDD Duty Cycle	TS i ; $i = 0, 1, 2, \dots, 14$: transmit, if i is even; receive, if i is odd.
Time slot carrying SCH	TS0
Time slots under test	TS i , i even and non zero
BS output power setting	PRAT
HS-PDSCH modulation	16QAM
Number of HS-PDSCH in each time slot under test	9
Power of each HS-PDSCH	1/9 of Base Station output power
Data content of HS-PDSCH	real life (sufficient irregular)
Spreading factor	32

6.8.2.4.2 Procedure

Measure the peak code domain error by applying the global in-channel Tx test method described in Annex C.

6.8.2.5 Test Requirements

NOTE: If the Test Requirement below differs from the Minimum Requirement, then the Test Tolerance applied for this test is non-zero. The Test Tolerance for this test is defined in subclause 5.11 and the explanation of how the Minimum Requirement has been relaxed by the Test Tolerance is given in Annex D.

The peak code domain error measured according to subclause 6.8.2.4.2 shall not exceed -27 dB.

6.8.3 Relative Code Domain Error

6.8.3.1 Definition and applicability

The Relative Code Domain Error is computed by projecting the error vector onto the code domain at a specified spreading factor. Only the active code channels in the composite reference waveform are considered for this requirement. The Relative Code Domain Error for every active code is defined as the ratio of the mean power of the error projection onto that code, to the mean power of the active code in the composite reference waveform. This ratio is expressed in dB. The measurement interval is one timeslot.

The requirement for Relative Code Domain Error is only applicable for 64QAM modulated codes.

6.8.3.2 Minimum requirement

The average Relative Code Domain Error for 64QAM modulated codes shall not exceed -21.9dB at spreading factor 16. The normative reference for this requirement is TS 25.105 [1] subclause 6.8.4.1

6.8.3.3 Test Purpose

It is the purpose of this test to verify that the Relative Code Domain Error is within the limit specified by 6.8.3.2.

6.8.3.4 Method of test

6.8.3.4.1 Initial conditions

For 1,28 Mcps BS supporting 64QAM, the RCDE requirement shall be tested with the general test set up specified in section 6.8.3.4.1.1 and also with the special test set up for 64QAM capable BS specified in section 6.8.3.4.1.2.

6.8.3.4.1.0 General test conditions

Test environment: normal; see subclause 5.9.1.

RF channels to be tested: B, M and T; see subclause 5.3.

6.8.3.4.1.1 1.28 Mcps TDD option- General test set up

(1) Connect the measuring equipment to the antenna connector of the BS under test.

(2) Set the parameters of the BS transmitted signal according to table 6.41..

Table 6.41: Parameters of the BS transmitted signal for 1,28 Mcps TDD

Parameter	Value/description
TDD Duty Cycle	TS i ; $i = 0, 1, 2, \dots, 6$: transmit, if i is 0,4,5,6; receive, if i is 1,2,3.
Time slots under test	TS4, TS5 and TS6
BS output power setting	PRAT
Number of HS-PDSCH in each time slot under test	10
Power of each HS-PDSCH	1/10 of Base Station output power
Data content of HS-PDSCH	real life (sufficient irregular)
Spreading factor	16

6.8.3.4.1.2 1.28 Mcps TDD option - Special test set up for 64QAM capable BS

This test set up only applies for 64QAM capable BS.

(1) Connect the measuring equipment to the antenna connector of the BS under test.

(2) Set the parameters of the BS transmitted signal according to table 6.41A.

Table 6.41A: Parameters of the BS transmitted signal for 1,28 Mcps TDD - 64QAM capable BS

Parameter	Value/description
TDD Duty Cycle	TS i ; $i = 0, 1, 2, \dots, 6$: transmit, if i is 0,4,5,6; receive, if i is 1,2,3.
Time slots under test	TS4, TS5 and TS6
HS-PDSCH modulation	64QAM
BS output power setting	PRAT
Number of HS-PDSCH in each time slot under test	10
Power of each HS-PDSCH	1/10 of Base Station output power
Data content of HS-PDSCH	real life (sufficient irregular)
Spreading factor	16

6.8.3.4.2 Procedure

Measure the Relative code domain error by applying the global in-channel Tx test method described in Annex C.

6.8.3.5 Test Requirements

NOTE: If the Test Requirement below differs from the Minimum Requirement, then the Test Tolerance applied for this test is non-zero. The Test Tolerance for this test is defined in subclause 5.11 and the explanation of how the Minimum Requirement has been relaxed by the Test Tolerance is given in Annex D.

The Relative code domain error measured according to subclause 6.8.3.4.2 shall not exceed -20.9 dB.

6.8.4 Time alignment error in MIMO transmission

6.8.4.1 Definition and applicability

In MIMO transmission, signals are transmitted from two or more antennas. These signals shall be aligned. The time alignment error in MIMO transmission is specified as the delay between the signals from two antennas at the antenna ports.

This test is only applicable for Node B supporting MIMO transmission.

6.8.4.2 Minimum requirement

The time alignment error in MIMO for any possible configuration of two transmit antennas shall not exceed 65 ns.

The normative reference for this requirement is TS 25.105 [1] subclause 6.8.5.1.

6.8.4.3 Test Purpose

It is the purpose of this test to verify that the timing alignment error in MIMO is within the limit specified in 6.8.4.2.

6.8.4.4 Method of test

6.8.4.4.1 Initial conditions

For 1,28 Mcps BS supporting MIMO transmission, the time alignment error shall be tested with the general test set up specified in section 6.8.4.4.1.1.

6.8.4.4.1.0 General test conditions

Test environment: normal; see subclause 5.9.1.

RF channels to be tested: Middle; see subclause 5.3.

6.8.4.4.1.1 1.28 Mcps TDD option- General test set up

- 1) Connect two base station RF antenna ports to the measurement equipment as shown in Figure 6.6. If available terminate the other unused antenna ports.

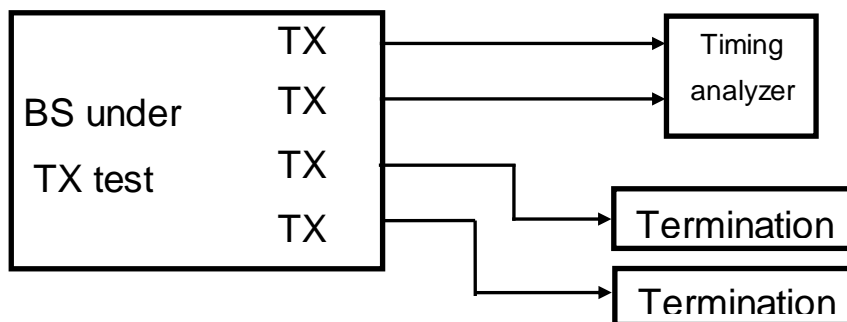

Figure 6.6: Measuring system Set-up for Test of Time alignment error

- 2) Set the base station to transmit P-CCPCH and DwPTS using all the antennas. Set the parameters of the BS transmitted signal according to table 6.42.

Table 6.42: Parameters of the BS transmitted signal for 1,28 Mcps TDD

Parameter	Value/description
TDD Duty Cycle	TS i ; $i = 0, 1, 2, \dots, 6$: transmit, if i is 0,4,5,6; receive, if i is 1,2,3.
Time slots under test	TS0 and DwPTS
BS output power setting	PRAT
Spreading factor	16

- 3) Set BS frequency.

6.8.4.4.2 Procedure

6.8.4.4.2.1 1.28 Mcps TDD option

- 1) Start BS transmission at the manufacturer's specified maximum output power.
- 2) Measure the time alignment error between the P-CCPCH and DwPTS on the antenna ports under test.
- 3) Repeat the measurement for any other possible configuration of 2 transmit antennas.

6.8.4.5 Test Requirements

NOTE: If the Test Requirement below differs from the Minimum Requirement, then the Test Tolerance applied for this test is non-zero. The Test Tolerance for this test is defined in subclause 5.1.1 and the explanation of how the Minimum Requirement has been relaxed by the Test Tolerance is given in Annex D.

6.8.4.5.1 1.28 Mcps TDD option

The time alignment error shall be less than $65+[78]ns$.

7 Receiver characteristics

7.1 General

The requirements in clause 7 are expressed for a single receiver antenna connector. For receivers with antenna diversity, the requirements apply for each receiver antenna connector.

For ACS, blocking and intermodulation characteristics, the negative offsets of the interfering signal apply relative to the assigned channel frequency of the lowest carrier frequency used and positive offsets of the interfering signal apply relative to the assigned channel frequency of the highest carrier frequency used.

A BS supporting 1.28Mcps MC-HSUPA receives multiple carriers simultaneously on adjacent carrier frequencies.

All tests unless otherwise stated in this subclause shall be conducted on Base Station Systems fitted with a full complement of Transceivers for the configuration. The manufacturer shall provide appropriate logical or physical test access to perform all tests in this subclause. Measurements shall include any RX multicoupler.

In all the relevant subclauses in this clause all Bit Error Ratio (BER), Residual BER (RBER) and Frame Erasure Ratio (FER) measurements shall be carried out according to the general rules for statistical testing defined in ITU-T Recommendation O.153 [10] and Annex F.

Unless otherwise stated, all tests in this clause shall be performed at the BS antenna connector (test port A). If any external apparatus such as a RX amplifier, a filter or the combination of such devices is used, the tests according to subclauses 5.14.4 shall be performed to ensure that the requirements are met at test port B.

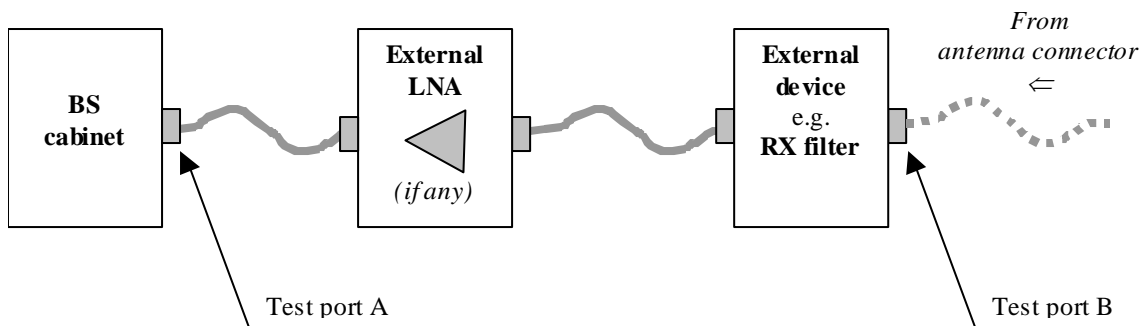

Figure 7.1: Receiver test ports

7.2 Reference sensitivity level

7.2.1 Definition and applicability

The reference sensitivity level is the minimum mean power received at the antenna connector at which the BER shall not exceed the specific value.

In this subclause, different requirements shall apply to Wide Area BS, Local Area BS and Home BS.

7.2.2 Minimum Requirements

7.2.2.1 3,84 Mcps TDD option

Using the reference measurement channel specified in Annex A.2.1, the reference sensitivity level and performance of the BS shall be as specified in table 7.1.

Table 7.1: Minimum Requirements for BS reference sensitivity level

BS class	Reference measurement channel data rate	BS reference sensitivity level	BER
Wide Area BS	12,2 kbps	-109 dBm	BER shall not exceed 0,001
Local Area BS	12,2 kbps	-95 dBm	BER shall not exceed 0,001

The normative reference for this requirement is TS 25.105 [1] subclause 7.2.1.1.

7.2.2.2 1,28 Mcps option

Using the reference measurement channel specified in Annex A.2.1.2, the reference sensitivity level and performance of the BS shall be as specified in table 7.1A.

Table 7.1A: Minimum Requirements for BS reference sensitivity level (1,28 Mcps option)

BS class	Reference measurement channel data rate	BS reference sensitivity level	BER
Wide Area BS	12,2 kbps	-110 dBm	BER shall not exceed 0,001
Local Area BS	12,2 kbps	-96 dBm	BER shall not exceed 0,001
Home BS	12,2 kbps	-101 dBm	BER shall not exceed 0,001

The normative reference for this requirement is TS 25.105 [1] subclause 7.2.1.2.

7.2.2.3 7,68 Mcps TDD option

Using the reference measurement channel specified in Annex A.2.1, the reference sensitivity level and performance of the BS shall be as specified in table 7.1B.

Table 7.1B: Minimum Requirements for BS reference sensitivity level

BS class	Reference measurement channel data rate	BS reference sensitivity level	BER
Wide Area BS	12,2 kbps	-109 dBm	BER shall not exceed 0,001
Local Area BS	12,2 kbps	-95 dBm	BER shall not exceed 0,001

The normative reference for this requirement is TS 25.105 [1] subclause 7.2.1.3.

7.2.3 Test purpose

The test purpose is to verify the ability of the BS to receive a prescribed single-code test signal of minimum input power under defined conditions (no interference, no multipath propagation) with a BER not exceeding a specified limit. This test is also used as a reference case for other tests to allow the assessment of degradations due to various sources of interference.

7.2.4 Method of test

7.2.4.1 Initial conditions

7.2.4.1.0 General test requirements

Test environment: normal; see subclause 5.9.1.

RF channels to be tested: B, M and T; see subclause 5.3.

The following additional test shall be performed:

On each of B, M and T, the test shall be performed under extreme power supply as defined in subclause 5.9.4.

NOTE: Tests under extreme power supply also test extreme temperature.

7.2.4.1.1 3,84 Mcps TDD option

- (1) Connect the BS tester (UE simulator) to the antenna connector of one BS Rx port.
- (2) Terminate or disable any other BS Rx port not under test.
- (3) Start transmission from the BS tester to the BS using the UL reference measurement channel (12.2 kbps) defined in Annex A.2.1.
- (4) The level of the BS tester output signal measured at the BS antenna connector shall be adjusted to the Test Requirement for the BS reference sensitivity level specified in table 7.2.

7.2.4.1.2 1,28 Mcps TDD option

- (1) Connect the BS tester (UE simulator) to the antenna connector of one BS Rx port.
- (2) Terminate or disable any other BS Rx port not under test.
- (3) Start transmission from the BS tester to the BS using the UL reference measurement channel (12.2 kbps) defined in Annex A.2.1.

- (4) The level of BS tester output signal measured at the BS antenna connector shall be adjusted to -110 dBm.

7.2.4.1.3 7,68 Mcps TDD option

- (1) Connect the BS tester (UE simulator) to the antenna connector of one BS Rx port.
- (2) Terminate or disable any other BS Rx port not under test.
- (3) Start transmission from the BS tester to the BS using the UL reference measurement channel (12.2 kbps) defined in Annex A.2.1.
- (4) The level of the BS tester output signal measured at the BS antenna connector shall be adjusted to the Test Requirement for the BS reference sensitivity level specified in table 7.2B.

7.2.4.2 Procedure

- (1) Calculate BER according to annex F.
- (2) Set the test signal mean power as specified in table 7.1A.
- (3) Measure BER.
- (4) Interchange the connections of the BS Rx ports and repeat the measurement according to (1).

7.2.5 Test Requirements

NOTE: If the Test Requirements below differ from the Minimum Requirements, then the Test Tolerance applied for this test is non-zero. The Test Tolerance for this test is defined in subclause 5.11 and the explanation of how the Minimum Requirement has been relaxed by the Test Tolerance is given in Annex D.

7.2.5.1 3,84 Mcps TDD option

For any BS Rx port tested, the measured BER at the Test Requirement of the BS reference sensitivity level specified in table 7.2 shall not exceed 0,001.

Table 7.2: Test Requirement for BS reference sensitivity level

BS class	Reference measurement channel data rate	BS reference sensitivity level	BER
Wide Area BS	12,2 kbps	-108,3 dBm	BER shall not exceed 0,001
Local Area BS	12,2 kbps	-94,3 dBm	BER shall not exceed 0,001

7.2.5.2 1,28 Mcps TDD option

For any BS Rx port tested, the measured BER at the Test Requirement of the BS reference sensitivity level specified in table 7.2A shall not exceed 0,001.

Table 7.2A: Test Requirement for BS reference sensitivity level for 1,28 Mcps option

BS class	Reference measurement channel data rate	BS reference sensitivity level	BER
Wide Area BS	12,2 kbps	-109,3 dBm	BER shall not exceed 0,001
Local Area BS	12,2 kbps	-95,3 dBm	BER shall not exceed 0,001
Home BS	12,2 kbps	-100,3 dBm	BER shall not exceed 0,001

7.2.5.3 7,68 Mcps TDD option

For any BS Rx port tested, the measured BER at the Test Requirement of the BS reference sensitivity level specified in table 7.2B shall not exceed 0,001.

Table 7.2B: Test Requirement for BS reference sensitivity level

BS class	Reference measurement channel data rate	BS reference sensitivity level	BER
Wide Area BS	12,2 kbps	-108,3 dBm	BER shall not exceed 0,001
Local Area BS	12,2 kbps	-94,3 dBm	BER shall not exceed 0,001

7.3 Dynamic range

7.3.1 Definition and applicability

Receiver dynamic range is the receiver ability to handle a rise of interference in the reception frequency channel. The receiver shall fulfil a specified BER requirement for a specified sensitivity degradation of the wanted signal in the presence of an interfering AWGN signal in the same reception frequency channel.

In this subclause, different requirements shall apply to Wide Area BS and Local Area BS.

7.3.2 Minimum Requirements

7.3.2.1 3,84 Mcps TDD option

The BER shall not exceed 0,001 for the parameters specified in table 7.3.

Table 7.3: Minimum Requirements for Dynamic Range

Parameter		Level	Unit
Reference measurement channel data rate		12,2	kbit/s
Wanted signal mean power	Wide Area BS	-79	dBm
	Local Area BS	-65	dBm
Interfering AWGN signal	Wide Area BS	-73	dBm/3,84 MHz
	Local Area BS	-59	dBm/3,84 MHz

The normative reference for this requirement is TS 25.105 [1] subclause 7.3.1.1.

7.3.2.2 1,28 Mcps TDD option

The BER shall not exceed 0,001 for the parameters specified in table 7.3A.

Table 7.3A: Minimum Requirements for Dynamic Range for 1,28 Mcps TDD

Parameter		Level	Unit
Reference measurement channel data rate		12,2	kbit/s
Wanted signal mean power	Wide Area BS	-80	dBm
	Local Area BS	-66	dBm
	Home BS	-51	dBm
Interfering AWGN signal	Wide Area BS	-76	dBm/1,28 MHz
	Local Area BS	-62	dBm/1,28 MHz
	Home BS	-47	dBm

The normative reference for this requirement is TS 25.105 [1] subclause 7.3.1.2.

7.3.2.3 7,68 Mcps TDD option

The BER shall not exceed 0,001 for the parameters specified in table 7.3B.

Table 7.3B: Minimum Requirements for Dynamic Range

Parameter		Level	Unit
Reference measurement channel data rate		12,2	kbit/s
Wanted signal mean power	Wide Area BS	-79	dBm
	Local Area BS	-65	dBm
Interfering AWGN signal	Wide Area BS	-70	dBm/7,68 MHz
	Local Area BS	-56	dBm/7,68 MHz

The normative reference for this requirement is TS 25.105 [1] subclause 7.3.1.3.

7.3.3 Test purpose

The test purpose is to verify the ability of the BS to receive a prescribed single-code test signal of maximum input power under defined conditions (specified interference, no multipath) with a BER not exceeding a specified limit.

7.3.4 Method of test

7.3.4.1 Initial conditions

7.3.4.1.0 General test conditions

Test environment: normal; see subclause 5.9.1.

RF channels to be tested: B, M and T; see subclause 5.3.

7.3.4.1.1 3,84 Mcps TDD option

- (1) Connect the BS tester (UE simulator), generating the wanted signal, and a band-limited white noise source, generating the interfering AWGN signal, to the antenna connector of one BS Rx port.
- (2) Terminate or disable any other BS Rx port not under test.
- (3) Start transmission from the BS tester to the BS using the UL reference measurement channel (12,2 kbps) defined in Annex A.2.1.
- (4) The level of the BS tester output signal measured at the BS antenna connector shall be adjusted as specified in table 7.4.
- (5) The power spectral density of the band-limited white noise source measured at the BS antenna connector shall be adjusted as specified in table 7.4. The characteristics of the white noise source shall comply with the AWGN interferer definition in subclause 5.18

7.3.4.1.2 1,28 Mcps TDD option

- (1) Connect the BS tester (UE simulator), generating the wanted signal, and a band-limited white noise source, generating the interfering AWGN signal, to the antenna connector of one BS Rx port.
- (2) Terminate or disable any other BS Rx port not under test.
- (3) Start transmission from the BS tester to the BS using the UL reference measurement channel (12,2 kbps) defined in Annex A.2.1.
- (4) The level of the BS tester output signal measured at the BS antenna connector shall be adjusted as specified in table 7.3A.

- (5) The power spectral density of the band-limited white noise source measured at the BS antenna connector shall be adjusted as specified in table 7.3A. The characteristics of the white noise source shall comply with the AWGN interferer definition in subclause 5.18.

7.3.4.1.3 7,68 Mcps TDD option

- (1) Connect the BS tester (UE simulator), generating the wanted signal, and a band-limited white noise source, generating the interfering AWGN signal, to the antenna connector of one BS Rx port.
- (2) Terminate or disable any other BS Rx port not under test.
- (3) Start transmission from the BS tester to the BS using the UL reference measurement channel (12,2 kbps) defined in Annex A.2.1.
- (4) The level of the BS tester output signal measured at the BS antenna connector shall be adjusted as specified in table 7.4B.
- (5) The power spectral density of the band-limited white noise source measured at the BS antenna connector shall be adjusted as specified in table 7.4B. The characteristics of the white noise source shall comply with the AWGN interferer definition in subclause 5.18

7.3.4.2 Procedure

- (1) Measure the BER by comparing the bit sequence of the information data transmitted by the BS tester with the bit sequence obtained from the BS receiver.
- (2) Interchange the connections of the BS Rx ports and repeat the measurement according to (1)

7.3.5 Test Requirements

NOTE: If the Test Requirement below differs from the Minimum Requirement, then the Test Tolerance applied for this test is non-zero. The Test Tolerance for this test is defined in subclause 5.11 and the explanation of how the Minimum Requirement has been relaxed by the Test Tolerance is given in Annex D.

7.3.5.1 3,84 Mcps TDD option

For any BS Rx port tested, the measured BER shall not exceed 0,001 for the parameters specified in table 7.4.

Table 7.4: Test Requirements for Dynamic Range

Parameter		Level	Unit
Reference measurement channel data rate		12,2	kbit/s
Wanted signal mean power	Wide Area BS	-77,8	dBm
	Local Area BS	-63,8	dBm
Interfering AWGN signal	Wide Area BS	-73	dBm/3,84 MHz
	Local Area BS	-59	dBm/3,84 MHz

7.3.5.2 1,28 Mcps TDD option

For any BS Rx port tested, the measured BER shall not exceed 0,001 for the parameters specified in table 7.4A.

Table 7.4A: Test Requirements for Dynamic Range for 1,28 Mcps TDD option

Parameter		Level	Unit
Reference measurement channel data rate		12,2	kbit/s
Wanted signal mean power	Wide Area BS	-78,8	dBm
	Local Area BS	-64,8	dBm
	Home BS	-49,8	dBm/1,28 MHz
Interfering AWGN signal	Wide Area BS	-76	dBm/1,28 MHz
	Local Area BS	-62	dBm/1,28 MHz
	Home BS	-47	dBm/1,28 MHz

7.3.5.3 7,68 Mcps TDD option

For any BS Rx port tested, the measured BER shall not exceed 0,001 for the parameters specified in table 7.4B.

Table 7.4B: Test Requirements for Dynamic Range

Parameter		Level	Unit
Reference measurement channel data rate		12,2	kbit/s
Wanted signal mean power	Wide Area BS	-77,8	dBm
	Local Area BS	-63,8	dBm
Interfering AWGN signal	Wide Area BS	-70	dBm/7,68 MHz
	Local Area BS	-56	dBm/7,68 MHz

7.4 Adjacent Channel Selectivity (ACS)

7.4.1 Definition and applicability

Adjacent channel selectivity (ACS) is a measure of the receiver ability to receive a wanted signal at its assigned channel frequency in the presence of a single code CDMA modulated adjacent channel signal at a given frequency offset from the center frequency of the assigned channel.

In this subclause, different requirements shall apply to Wide Area BS and Local Area BS.

7.4.2 Minimum Requirements

7.4.2.1 3,84 Mcps TDD option

The BER, measured on the wanted signal in the presence of an interfering signal, shall not exceed 0,001 for the parameters specified in table 7.5.

Table 7.5: Parameters of the wanted signal and the interfering signal for ACS testing

Parameter		Level	Unit
Reference measurement channel data rate		12,2	kbit/s
Wanted signal mean power	Wide Area BS	-103	dBm
	Local Area BS	-89	dBm
Interfering signal mean power	Wide Area BS	-52	dBm
	Local Area BS	-38	dBm
Fuw (modulated)		5	MHz
NOTE: Fuw is the frequency offset of the unwanted interfering signal from the assigned channel frequency of the wanted signal.			

The normative reference for this requirement is TS 25.105 [1] subclause 7.4.1.1.

7.4.2.2 1,28 Mcps TDD option

The BER, measured on the wanted signal in the presence of an interfering signal, shall not exceed 0,001 for the parameters specified in table 7.5A.

Table 7.5A: Parameters of the wanted signal and the interfering signal for ACS testing for 1,28 Mcps TDD

Parameter		Level	Unit
Reference measurement channel data rate		12,2	kbit/s
Wanted signal mean power	Wide Area BS	-104	dBm
	Local Area BS	-90	dBm
	Home BS	-77	dBm
Interfering signal mean power	Wide Area BS	-55	dBm
	Local Area BS	-41	dBm
	Home BS	-28	dBm
Fuw (modulated)		±1,6	MHz
NOTE: Fuw is the frequency offset of the unwanted interfering signal from the assigned channel frequency of the wanted signal.			

The normative reference for this requirement is TS 25.105 [1] subclause 7.4.1.2.

7.4.2.3 7,68 Mcps TDD option

The BER, measured on the wanted signal in the presence of an interfering signal, shall not exceed 0,001 for the parameters specified in table 7.5B.

Table 7.5B: Parameters of the wanted signal and the interfering signal for ACS testing

Parameter		Level	Unit
Reference measurement channel data rate		12,2	kbit/s
Wanted signal mean power	Wide Area BS	-103	dBm
	Local Area BS	-89	dBm
Interfering signal mean power	Wide Area BS	-49	dBm
	Local Area BS	-35	dBm
Fuw (modulated)		10	MHz
NOTE: Fuw is the frequency offset of the unwanted interfering signal from the assigned channel frequency of the wanted signal.			

The normative reference for this requirement is TS 25.105 [1] subclause 7.4.1.3.

7.4.3 Test purpose

The test purpose is to verify the ability of the BS receiver filter to sufficiently suppress interfering signals in the channels adjacent to the wanted channel.

7.4.4 Method of test

7.4.4.1 Initial conditions

7.4.4.1.0 General test conditions

Test environment: normal; see subclause 5.9.1.

RF channels to be tested: B, M and T; see subclause 5.3.

7.4.4.1.1 3,84 Mcps TDD option

- (1) Connect an UE simulator operating at the assigned channel frequency of the wanted signal and a signal generator used to produce the interfering signal in the adjacent channel to the antenna connector of one Rx port.
- (2) Terminate or disable any other Rx port not under test.
- (3) Start transmission from the BS tester to the BS using the UL reference measurement channel (12,2 kbps) defined in Annex A.2.1. The level of the UE simulator signal measured at the BS antenna connector shall be adjusted to the value specified in table 7.5.
- (4) Set the signal generator to produce an interfering signal that is equivalent to a continuous wideband CDMA signal with one code of chip frequency 3,84 Mchip/s, filtered by an RRC transmit pulse-shaping filter with roll-off $\alpha = 0,22$. The mean power level of the interfering signal measured at the BS antenna connector shall be adjusted to the value specified in table 7.5.

7.4.4.1.2 1,28 Mcps TDD option

- (1) Connect an UE simulator operating at the assigned channel frequency of the wanted signal and a signal generator used to produce the interfering signal in the adjacent channel to the antenna connector of one Rx port.
- (2) Terminate or disable any other Rx port not under test.
- (3) Start transmission from the BS tester to the BS using the UL reference measurement channel (12,2 kbps) defined in Annex A.2.1. The level of the UE simulator signal measured at the BS antenna connector shall be adjusted to the value specified in table 7.5A.
- (4) Set the signal generator to produce an interfering signal that is equivalent to a continuous wideband CDMA signal with one code of chip frequency 1,28 Mchip/s, filtered by an RRC transmit pulse-shaping filter with roll-off $\alpha = 0,22$. The mean power level of the interfering signal measured at the BS antenna connector shall be adjusted to the value specified in table 7.5A.

7.4.4.1.3 7,68 Mcps TDD option

- (1) Connect an UE simulator operating at the assigned channel frequency of the wanted signal and a signal generator used to produce the interfering signal in the adjacent channel to the antenna connector of one Rx port.
- (2) Terminate or disable any other Rx port not under test.
- (3) Start transmission from the BS tester to the BS using the UL reference measurement channel (12,2 kbps) defined in Annex A.2.1. The level of the UE simulator signal measured at the BS antenna connector shall be adjusted to the value specified in table 7.5B.
- (4) Set the signal generator to produce an interfering signal that is equivalent to a continuous wideband CDMA signal with one code of chip frequency 7,68 Mchip/s, filtered by an RRC transmit pulse-shaping filter with roll-off $\alpha = 0,22$. The mean power level of the interfering signal measured at the BS antenna connector shall be adjusted to the value specified in table 7.5B.

7.4.4.2 Procedure

7.4.4.2.1 3,84 Mcps TDD option

- (1) Set the center frequency of the interfering signal to 5 MHz above the assigned channel frequency of the wanted signal.
- (2) Measure the BER of the wanted signal at the BS receiver.
- (3) Set the center frequency of the interfering signal to 5 MHz below the assigned channel frequency of the wanted signal.
- (4) Measure the BER of the wanted signal at the BS receiver.
- (5) Interchange the connections of the BS Rx ports and repeat the measurements according to steps (1) to (4).

7.4.4.2.2 1,28 Mcps TDD option

- (1) Set the center frequency of the interfering signal to 1,6 MHz above the assigned channel frequency of the wanted signal.
- (2) Measure the BER of the wanted signal at the BS receiver.
- (3) Set the center frequency of the interfering signal to 1,6 MHz below the assigned channel frequency of the wanted signal.
- (4) Measure the BER of the wanted signal at the BS receiver.
- (5) Interchange the connections of the BS Rx ports and repeat the measurements according to steps (1) to (4).

7.4.4.2.3 7,68 Mcps TDD option

- (1) Set the center frequency of the interfering signal to 10 MHz above the assigned channel frequency of the wanted signal.
- (2) Measure the BER of the wanted signal at the BS receiver.
- (3) Set the center frequency of the interfering signal to 10 MHz below the assigned channel frequency of the wanted signal.
- (4) Measure the BER of the wanted signal at the BS receiver.
- (5) Interchange the connections of the BS Rx ports and repeat the measurements according to steps (1) to (4).

7.4.5 Test Requirements

NOTE: If the Test Requirement below differs from the Minimum Requirement, then the Test Tolerance applied for this test is non-zero. The Test Tolerance for this test is defined in subclause 5.11 and the explanation of how the Minimum Requirement has been relaxed by the Test Tolerance is given in Annex D.

The BER measured according to subclause 7.4.4.2 shall not exceed 0,001.

7.5 Blocking characteristics

7.5.1 Definition and applicability

7.5.1.1 3,84 Mcps TDD option

The blocking characteristics is a measure of the receiver ability to receive a wanted signal at its assigned channel frequency in the presence of an unwanted interferer on frequencies other than those of the adjacent channels. The blocking performance requirements apply to interfering signals with center frequency within the ranges specified in tables 7.6-1, 7.7-1, 7.8-1, 7.9-1, 7.6-2, 7.7-2, 7.8-2, 7.9-2, 7.9 and 7.10 respectively, using a 1 MHz step size.

In this subclause, different requirements shall apply to Wide Area BS and Local Area BS. The requirements in tables 7.6-1, 7.7-1, 7.8-1, 7.9-1 apply to Wide Area BS, and the requirements in tables 7.6-2, 7.7-2, 7.8-2 or 7.9-2 apply to Local Area BS, depending on which frequency band is used. The additional requirements in Tables 7.9 and 7.10 may be applied for the protection of TDD BS receivers when GSM900 and/or DCS1800 BTS are co-located with UTRA TDD Wide Area BS.

7.5.1.2 1,28 Mcps TDD option

The blocking characteristics is a measure of the receiver ability to receive a wanted signal at its assigned channel frequency in the presence of an unwanted interferer on frequencies other than those of the adjacent channels. The blocking performance requirements apply to interfering signals with center frequency within the ranges specified in tables 7.6A-1, 7.7A-1, 7.8A-1, 7.8B-1, 7.8C-1, 7.6A-2, 7.7A-2, 7.8A-2, 7.8B-2, 7.8C-2, 7.9A and 7.10A respectively, using a 1 MHz step size.

In this subclause, different requirements apply to Wide Area BS and Local Area BS. The requirements in tables 7.6A-1, 7.7A-1, 7.8A-1 7.8B-1 or 7.8C-1 apply to Wide Area BS, and the requirements in tables 7.6A-2, 7.7A-2, 7.8A-2, 7.8B-2 or 7.8C-2 apply to Local Area BS, depending on which frequency band is used. The additional requirements in Tables 7.9A and 7.10A may be applied for the protection of TDD BS receivers when GSM900 and/or DCS1800 BTS are co-located with UTRA TDD Wide Area BS.

7.5.1.3 7,68 Mcps TDD option

The blocking characteristics is a measure of the receiver ability to receive a wanted signal at its assigned channel frequency in the presence of an unwanted interferer on frequencies other than those of the adjacent channels. The blocking performance requirements apply to interfering signals with center frequency within the ranges specified in tables 7.6-1B, 7.7-1B, 7.8-1B, 7.6-2B, 7.7-2B, 7.8-2B, 7.9B and 7.10F respectively, using a 1 MHz step size.

In this subclause, different requirements shall apply to Wide Area BS and Local Area BS. The requirements in tables 7.6-1B, 7.7-1B or 7.8-1B apply to Wide Area BS, and the requirements in tables 7.6-2B, 7.7-2B or 7.8-2B apply to Local Area BS, depending on which frequency band is used. The additional requirements in Tables 7.9B and 7.10F may be applied for the protection of TDD BS receivers when GSM900 and/or DCS1800 BTS are co-located with UTRA TDD Wide Area BS.

7.5.2 Minimum Requirements

7.5.2.1 3,84 Mcps TDD option

7.5.2.1.1 General requirements

The static reference performance as specified in clause 7.2 shall be met with a wanted and an interfering signal coupled to the BS antenna input using the parameters specified in tables 7.6-1, 7.7-1, 7.8-1, 7.9-1, 7.6-2, 7.7-2, 7.8-2 or 7.9-2, respectively.

Table 7.6-1: Blocking requirements for Wide Area BS in operating bands defined in subclause 4.2 a)

Center frequency of interfering signal	Interfering signal mean power	Wanted signal mean power	Minimum offset of interfering signal	Type of interfering signal
1900 - 1920 MHz, 2010 - 2025 MHz	-40 dBm	-103 dBm	10 MHz	WCDMA signal with one code
1880 - 1900 MHz, 1990 - 2010 MHz, 2025 - 2045 MHz	-40 dBm	-103 dBm	10 MHz	WCDMA signal with one code
1920 - 1980 MHz	-40 dBm	-103 dBm	10 MHz	WCDMA signal with one code
1 - 1880 MHz, 1980 - 1990 MHz, 2045 - 12750 MHz	-15 dBm	-103 dBm	—	CW carrier

Table 7.7-1: Blocking requirements for Wide Area BS in operating bands defined in subclause 4.2 b)

Center frequency of interfering signal	Interfering signal mean power	Wanted signal mean power	Minimum offset of interfering signal	Type of interfering signal
1850 - 1990 MHz	-40 dBm	-103 dBm	10 MHz	WCDMA signal with one code
1830 - 1850 MHz, 1990 - 2010 MHz	-40 dBm	-103 dBm	10 MHz	WCDMA signal with one code
1 - 1830 MHz, 2010 - 12750 MHz	-15 dBm	-103 dBm	—	CW carrier

Table 7.8-1: Blocking requirements for Wide Area BS in operating bands defined in subclause 4.2 c)

Center frequency of interfering signal	Interfering signal mean power	Wanted signal mean power	Minimum offset of interfering signal	Type of interfering signal
1910 - 1930 MHz	-40 dBm	-103 dBm	10 MHz	WCDMA signal with one code
1890 - 1910 MHz, 1930 - 1950 MHz	-40 dBm	-103 dBm	10 MHz	WCDMA signal with one code
1 - 1890 MHz, 1950 - 12750 MHz	-15 dBm	-103 dBm	—	CW carrier

Table 7.9-1: Blocking requirements for Wide Area BS in operating bands defined in subclause 4.2 d)

Center frequency of interfering signal	Interfering signal mean power	Wanted signal mean power	Minimum offset of interfering signal	Type of interfering signal
2570 - 2620 MHz	-40 dBm	-103 dBm	10 MHz	WCDMA signal with one code
2550 - 2570 MHz 2620 - 2640 MHz	-40 dBm	-103 dBm	10 MHz	WCDMA signal with one code
2500 - 2570 MHz 2620 - 2690 MHz	-40 dBm	-103 dBm	10 MHz	WCDMA signal with one code
1 - 2550 MHz, 2690 - 12750 MHz	-15 dBm	-103 dBm	—	CW carrier

Table 7.6-2: Blocking requirements for Local Area BS in operating bands defined in subclause 4.2 a)

Center frequency of interfering signal	Interfering signal level	Wanted signal level	Minimum offset of interfering signal	Type of interfering signal
1900 - 1920 MHz, 2010 - 2025 MHz	-30 dBm	<REFSENS> + 6 dB	10 MHz	WCDMA signal with one code
1880 - 1900 MHz, 1990 - 2010 MHz, 2025 - 2045 MHz	-30 dBm	<REFSENS> + 6 dB	10 MHz	WCDMA signal with one code
1920 - 1980 MHz	-30 dBm	<REFSENS> + 6 dB	10 MHz	WCDMA signal with one code
1 - 1880 MHz, 1980 - 1990 MHz, 2045 - 12750 MHz	-15 dBm	<REFSENS> + 6 dB	—	CW carrier

Table 7.7-2: Blocking requirements for Local Area BS in operating bands defined in subclause 4.2 b)

Center frequency of interfering signal	Interfering signal level	Wanted signal level	Minimum offset of interfering signal	Type of interfering signal
1850 - 1990 MHz	-30 dBm	<REFSENS> + 6 dB	10 MHz	WCDMA signal with one code
1830 - 1850 MHz, 1990 - 2010 MHz	-30 dBm	<REFSENS> + 6 dB	10 MHz	WCDMA signal with one code
1 - 1830 MHz, 2010 - 12750 MHz	-15 dBm	<REFSENS> + 6 dB	—	CW carrier

Table 7.8-2: Blocking requirements for Local Area BS in operating bands defined in subclause 4.2 c)

Center frequency of interfering signal	Interfering signal level	Wanted signal level	Minimum offset of interfering signal	Type of interfering signal
1910 - 1930 MHz	-30 dBm	<REFSENS> + 6 dB	10 MHz	WCDMA signal with one code
1890 - 1910 MHz, 1930 - 1950 MHz	-30 dBm	<REFSENS> + 6 dB	10 MHz	WCDMA signal with one code
1 - 1890 MHz, 1950 - 12750 MHz	-15 dBm	<REFSENS> + 6 dB	—	CW carrier

Table 7.9-2: Blocking requirements for Local Area BS in operating bands defined in subclause 4.2 d)

Center frequency of interfering signal	Interfering signal level	Wanted signal level	Minimum offset of interfering signal	Type of interfering signal
2570 - 2620 MHz	-30 dBm	<REFSENS> + 6 dB	10 MHz	WCDMA signal with one code
2550 - 2570 MHz 2620 - 2640 MHz	-30 dBm	<REFSENS> + 6 dB	10 MHz	WCDMA signal with one code
2500 - 2570 MHz 2620 - 2690 MHz	-30 dBm	<REFSENS> + 6 dB	10 MHz	WCDMA signal with one code
1 - 2550 MHz, 2690 - 12750 MHz	-15 dBm	<REFSENS> + 6 dB	—	CW carrier

The normative reference for this requirement is TS 25.105 [1] subclause 7.5.0.1.

7.5.2.1.2 Co-location with GSM, DCS, UTRA-FDD and/or E-UTRA FDD

This additional blocking requirement may be applied for the protection of TDD BS receivers when GSM, DCS, UTRA-FDD and/or E-UTRA-FDD BTS are co-located with UTRA TDD Wide Area BS.

The blocking performance requirement applies to interfering signals with center frequency within the ranges specified in the tables below, using a 1MHz step size.

In case this additional blocking requirement is applied, the static reference performance as specified in clause 7.2.1 shall be met with a wanted and an interfering signal coupled to BS antenna input using the following parameters.

Table 7.9: Additional blocking requirements for Wide Area BS in operating bands defined in subclause 4.2 a) and 4.2 d)

System type operating in the same geographic area	Center Frequency of Interfering Signal	Interfering Signal mean power	Wanted Signal mean power	Minimum Offset of Interfering Signal	Type of Interfering Signal	Note
GSM900	921 - 960 MHz	+16 dBm	-103 dBm	—	CW carrier	
DCS1800	1805 - 1880	+16 dBm	-103 dBm	—	CW carrier	
WA BS UTRA FDD Band VII or E-UTRA Band 7	2620 - 2690 MHz	+13 dBm	-103 dBm	—	CW carrier	This requirement does not apply to UTRA TDD BS operating in Band 5.2(a)
LA BS UTRA FDD Band VII or E-UTRA Band 7	2620 - 2690 MHz	-6 dBm	-103 dBm	—	CW carrier	This requirement does not apply to UTRA TDD BS operating in Band 5.2(a)
NOTE 1: These requirements do not apply when the interfering signal falls within the uplink operating band or in the 10 MHz immediately outside the uplink operating band.						
NOTE 2: Some combinations of bands may not be possible to co-site based on the requirements above. The current state-of-the-art technology does not allow a single generic solution for co-location of UTRA TDD with UTRA FDD or E-UTRA FDD on adjacent frequencies for 30dB BS-BS minimum coupling loss. However, there are certain site-engineering solutions that can be used. These techniques are addressed in TR 25.942 [9].						

Table 7.10: Void

The normative reference for this requirement is TS 25.105 [1] subclause 7.5.1.1.

7.5.2.1.3 Void

Table 7.10A: Void

Table 7.10B: Void

7.5.2.2 1,28 Mcps TDD option

7.5.2.2.1 General requirements

The static reference performance as specified in clause 7.2 shall be met with a wanted and an interfering signal coupled to the BS antenna input using the parameters specified in tables 7.6A-1, 7.7A-1, 7.8A-1, 7.9A-1, 7.6A-2, 7.7A-2, 7.8A-2 or 7.9A-2, respectively.

Table 7.6A-1: Blocking requirements for Wide Area BS in operating bands defined in subclause 4.2 a) for 1,28 Mcps TDD

Center frequency of interfering signal	Interfering signal mean power	Wanted signal mean power	Minimum offset of interfering signal	Type of interfering signal
1900 - 1920 MHz, 2010 - 2025 MHz	-40 dBm	-104 dBm	±3.2 MHz	1,28 Mcps TDD signal with one code
1880 - 1900 MHz, 1990 - 2010 MHz, 2025 - 2045 MHz	-40 dBm	-104 dBm	±3.2 MHz	1,28 Mcps TDD signal with one code
1920 - 1980 MHz	-40 dBm	-104 dBm	±3.2 MHz	1,28 Mcps TDD signal with one code
1 - 1880 MHz, 1980 - 1990 MHz, 2045 - 12750 MHz	-15 dBm	-104 dBm	—	CW carrier

Table 7.7A-1: Blocking requirements for Wide Area BS in operating bands defined in subclause 4.2 b) for 1,28 Mcps TDD

Center frequency of interfering signal	Interfering signal mean power	Wanted signal mean power	Minimum offset of interfering signal	Type of interfering signal
1850 - 1990 MHz	-40 dBm	-104 dBm	±3.2 MHz	1,28 Mcps TDD signal with one code
1830 - 1850 MHz, 1990 - 2010 MHz	-40 dBm	-104 dBm	±3.2 MHz	1,28 Mcps TDD signal with one code
1 - 1830 MHz, 2010 - 12750 MHz	-15 dBm	-104 dBm	—	CW carrier

Table 7.8A-1: Blocking requirements for Wide Area BS in operating bands defined in subclause 4.2 c) for 1,28 Mcps TDD

Center frequency of interfering signal	Interfering signal mean power	Wanted signal mean power	Minimum offset of interfering signal	Type of interfering signal
1910 - 1930 MHz	-40 dBm	-104 dBm	±3.2 MHz	1,28 Mcps TDD signal with one code
1890 - 1910 MHz, 1930 - 1950 MHz	-40 dBm	-104 dBm	±3.2 MHz	1,28 Mcps TDD signal with one code
1 - 1890 MHz, 1950 - 12750 MHz	-15 dBm	-104 dBm	—	CW carrier

Table 7.8B-1: Blocking requirements for Wide Area BS in operating bands defined in 4.2(d) for 1,28 Mcps TDD

Center Frequency of Interfering Signal	Interfering Signal Mean Power	Wanted Signal Mean Power	Minimum Offset of Interfering Signal	Type of Interfering Signal
2570 - 2620 MHz	-40dBm	-104 dBm	±3.2MHz	1,28 Mcps TDD signal with one code
2500 - 2570 MHz, 2620 - 2690 MHz	-40dBm	-104 dBm	±3.2 MHz	1,28 Mcps TDD signal with one code
1 - 2500 MHz, 2690 - 12750 MHz	-15 dBm	-104 dBm	—	CW carrier

Table 7.8C-1: Blocking requirements for Wide Area BS in operating bands defined in 4.2(e) for 1,28 Mcps TDD

Center Frequency of Interfering Signal	Interfering Signal Mean Power	Wanted Signal Mean Power	Minimum Offset of Interfering Signal	Type of Interfering Signal
2300 - 2400 MHz	-40dBm	-104 dBm	±3.2MHz	1,28 Mcps TDD signal with one code
2280 - 2300 MHz, 2400 - 2420MHz	-40dBm	-104 dBm	±3.2 MHz	1,28 Mcps TDD signal with one code
1 - 2280 MHz, 2420 - 12750 MHz	-15 dBm	-104 dBm	—	CW carrier

Table 7.8D-1: Blocking requirements for Wide Area BS in operating bands defined in 5.2(f) for 1.28Mcps TDD

Center Frequency of Interfering Signal	Interfering Signal Mean Power	Wanted Signal Mean Power	Minimum Offset of Interfering Signal	Type of Interfering Signal
1880 - 1920 MHz	-40dBm	-104 dBm	±3.2 MHz	Narrow band CDMA signal with one code
1860 - 1880 MHz, 1920 - 1940 MHz	-40dBm	-104 dBm	±3.2 MHz	Narrow band CDMA signal with one code
1 - 1860 MHz, 1940 - 12750 MHz	-15 dBm	-104 dBm	—	CW carrier

Table 7.6A-2: Blocking requirements for Local Area BS and Home BS in operating bands defined in subclause 4.2 a) for 1,28 Mcps TDD

Center frequency of interfering signal	Interfering signal level	Wanted signal level	Minimum offset of interfering signal	Type of interfering signal
1900 - 1920 MHz, 2010 - 2025 MHz	-30 dBm	<REFSENS> + 6 dB	±3,2 MHz	1,28 Mcps TDD signal with one code
1880 - 1900 MHz, 1990 - 2010 MHz, 2025 - 2045 MHz	-30 dBm	<REFSENS> + 6 dB	±3,2 MHz	1,28 Mcps TDD signal with one code
1920 - 1980 MHz	-30 dBm	<REFSENS> + 6 dB	±3,2 MHz	1,28 Mcps TDD signal with one code
1 - 1880 MHz, 1980 - 1990 MHz, 2045 - 12750 MHz	-15 dBm	<REFSENS> + 6 dB	—	CW carrier

Table 7.7A-2: Blocking requirements for Local Area BS and Home BS in operating bands defined in subclause 4.2 b) for 1,28 Mcps TDD

Center frequency of interfering signal	Interfering signal level	Wanted signal level	Minimum offset of interfering signal	Type of interfering signal
1850 - 1990 MHz	-30 dBm	<REFSENS> + 6 dB	±3,2 MHz	1,28 Mcps TDD signal with one code
1830 - 1850 MHz, 1990 - 2010 MHz	-30 dBm	<REFSENS> + 6 dB	±3,2 MHz	1,28 Mcps TDD signal with one code
1 - 1830 MHz, 2010 - 12750 MHz	-15 dBm	<REFSENS> + 6 dB	—	CW carrier

Table 7.8A-2: Blocking requirements for Local Area BS and Home BS in operating bands defined in subclause 4.2 c) for 1,28 Mcps TDD

Center frequency of interfering signal	Interfering signal level	Wanted signal level	Minimum offset of interfering signal	Type of interfering signal
1910 - 1930 MHz	-30 dBm	<REFSENS> + 6 dB	±3,2 MHz	1,28 Mcps TDD signal with one code
1890 - 1910 MHz, 1930 - 1950 MHz	-30 dBm	<REFSENS> + 6 dB	±3,2 MHz	1,28 Mcps TDD signal with one code
1 - 1890 MHz, 1950 - 12750 MHz	-15 dBm	<REFSENS> + 6 dB	—	CW carrier

Table 7.8B-2: Blocking requirements for Local Area BS and Home BS in operating bands defined in 4.2(d) for 1,28 Mcps TDD

Center Frequency of Interfering Signal	Interfering Signal mean power	Wanted Signal mean power	Minimum Offset of Interfering Signal	Type of Interfering Signal
2570 - 2620 MHz	-30 dBm	<REFSENS> + 6 dB	±3.2MHz	1,28 Mcps TDD signal with one code
2500 - 2570 MHz, 2620 - 2690 MHz	-30 dBm	<REFSENS> + 6 dB	±3.2 MHz	1,28 Mcps TDD signal with one code
1 - 2500 MHz, 2690 - 12750 MHz	-15 dBm	<REFSENS> + 6 dB	—	CW carrier

Table 7.8C-2: Blocking requirements for Local Area BS and Home BS in operating bands defined in 4.2(e) for 1,28 Mcps TDD

Center Frequency of Interfering Signal	Interfering Signal mean power	Wanted Signal mean power	Minimum Offset of Interfering Signal	Type of Interfering Signal
2300 - 2400 MHz	-30 dBm	<REFSENS> + 6 dB	±3.2MHz	1,28 Mcps TDD signal with one code
2280 - 2300 MHz, 2400 - 2420MHz	-30 dBm	<REFSENS> + 6 dB	±3.2 MHz	1,28 Mcps TDD signal with one code
1 - 2280 MHz, 2420 - 12750 MHz	-15 dBm	<REFSENS> + 6 dB	—	CW carrier

Table 7.8D-2: Blocking requirements for Local Area BS and Home BS in operating bands defined in 5.2(f)

Center Frequency of Interfering Signal	Interfering Signal mean power	Wanted Signal mean power	Minimum Offset of Interfering Signal	Type of Interfering Signal
1880-1920 MHz	-30 dBm	-90 dBm	± 3.2 MHz	Narrow band CDMA signal with one code
1860 - 1880 MHz, 1920 - 1940MHz	-30 dBm	-90 dBm	± 3.2 MHz	Narrow band CDMA signal with one code
1 - 1860 MHz, 1940 – 12750 MHz	-15 dBm	-90 dBm	—	CW carrier

The normative reference for this requirement is TS 25.105 [1] subclause 7.5.0.2.

7.5.2.2.2 Co-location with GSM, DCS, UTRA FDD and/or E-UTRA FDD, UTRA TDD and/or E-UTRA TDD

This additional blocking requirement may be applied for the protection of TDD BS receivers when GSM, DCS, UTRA FDD, E-UTRA FDD, FDD unsynchronized UTRA TDD and/or unsynchronized E-UTRA TDD BTS operating in a different frequency band are co-located with UTRA TDD Wide Area BS.

The blocking performance requirement applies to interfering signals with centre frequency within the ranges specified in the tables below, using a 1MHz step size.

In case this additional blocking requirement is applied, the static reference performance as specified in clause 7.2.1 shall be met with a wanted and an interfering signal coupled to BS antenna input using the following parameters.

Table 7.9A: Additional blocking requirements for Wide Area BS

System type operating in the same geographic area	Centre Frequency of Interfering Signal	Interfering Signal mean power	Wanted Signal mean power	Minimum Offset of Interfering Signal	Type of Interfering Signal	Note
Macro GSM900	921 – 960 MHz	+16 dBm	-104 dBm	—	CW carrier	
Macro DCS1800	1805 – 1880 MHz	+16 dBm	-104 dBm	—	CW carrier	For UTRA TDD BS operating in Band 5.2(f), it applies for 1805 - 1850 MHz
GSM850 or CDMA850	869 – 894 MHz	+16 dBm	-104 dBm	—	CW carrier	
WA BS UTRA FDD Band I or E-UTRA Band 1	2110 – 2170 MHz	+16 dBm	-104 dBm	—	CW carrier	
WA BS UTRA FDD Band iii or E-UTRA Band 3	1805 – 1880 MHz	+16 dBm	-104 dBm	—	CW carrier	For UTRA TDD BS operating in Band 5.2(f), the requirement is FFS
WA BS UTRA FDD Band V or E-UTRA Band 5	869 – 894 MHz	+16 dBm	-104 dBm	—	CW carrier	
WA BS UTRA FDD Band VII or E-UTRA Band 7	2620 – 2690 MHz	+16 dBm	-104 dBm	—	CW carrier	
WA UTRA TDD Band a) or E-UTRA Band 33	1900 – 1920 MHz	+16 dBm	-104 dBm	—	CW carrier	
WA UTRA TDD Band a) or E-UTRA Band 34	2010 – 2025 MHz	+16 dBm	-104 dBm	—	CW carrier	
WA UTRA TDD Band d) or E-UTRA Band 38	2570 – 2620 MHz	+16 dBm	-104 dBm	—	CW carrier	
WA UTRA TDD Band f) or E-UTRA Band 39	1880 – 1920 MHz	+16 dBm	-104 dBm	—	CW carrier	
WA UTRA TDD Band e) or E-UTRA Band 40	2300 – 2400 MHz	+16 dBm	-104 dBm	—	CW carrier	
WA E-UTRA Band 41	2496 – 2690 MHz	+16 dBm	-104 dBm	—	CW carrier	
WA E-UTRA Band 42	3400 – 3600 MHz	+16 dBm	-104 dBm	—	CW carrier	

WA E-UTRA Band 44	703 – 803 MHz	+16 dBm	-104 dBm	—	CW carrier	
Pico GSM850	869 – 894	-7 dBm	-104 dBm	—	CW carrier	
Pico GSM900	921 – 960	-7 dBm	-104 dBm	—	CW carrier	
Pico DCS1800	1805 – 1880	-7 dBm	-104 dBm	—	CW carrier	
LABS UTRA FDD Band I or E-UTRA Band 1	2110 – 2170	-6 dBm	-104 dBm	—	CW carrier	
LABS UTRA FDD Band III or E-UTRA Band 3	1805 – 1880 MHz	-6 dBm	-104 dBm	—	CW carrier	For UTRA TDD BS operating in Band 5.2(f), the requirement is FFS
LABS UTRA FDD Band V or E-UTRA Band 5	869 – 894 MHz	-6 dBm	-104 dBm	—	CW carrier	
LABS UTRA FDD Band VII or E-UTRA Band 7	2620 – 2690 MHz	-6 dBm	-104 dBm	—	CW carrier	
LA UTRA TDD Band a) or E-UTRA Band 33	1900 – 1920 MHz	-6 dBm	-104 dBm	—	CW carrier	
LA UTRA TDD Band a) or E-UTRA Band 34	2010 – 2025 MHz	-6 dBm	-104 dBm	—	CW carrier	
LA UTRA TDD Band d) or E-UTRA Band 38	2570 – 2620 MHz	-6 dBm	-104 dBm	—	CW carrier	
LA UTRA TDD Band f) or E-UTRA Band 39	1880 – 1920 MHz	-6 dBm	-104 dBm	—	CW carrier	
LA UTRA TDD Band e) or E-UTRA Band 40	2300 – 2400 MHz	-6 dBm	-104 dBm	—	CW carrier	
LA E-UTRA Band 41	2496 – 2690 MHz	-6 dBm	-104 dBm	—	CW carrier	
LA E-UTRA Band 42	3400 – 3600 MHz	-6 dBm	-104 dBm	—	CW carrier	
WA E-UTRA Band 44	703 – 803 MHz	-6 dBm	-104 dBm	—	CW carrier	

NOTE 1: These requirements do not apply when the interfering signal falls within the uplink operating band or in the 10 MHz immediately outside the uplink operating band.

NOTE 2: Some combinations of bands may not be possible to co-site based on the requirements above. The current state-of-the-art technology does not allow a single generic solution for co-location of UTRA TDD with UTRA FDD or E-UTRA FDD on adjacent frequencies for 30dB BS-BS minimum coupling loss. However, there are certain site-engineering solutions that can be used. These techniques are addressed

in TR 25.942 [9].

Table 7.10A: Void

Table 7.10A-1: Void

The normative reference for this requirement is TS 25.105 [1] subclause 7.5.1.2.

7.5.2.2.3 Void

Table 7.10B: Void

Table 7.10C: Void

7.5.2.3 7,68 Mcps TDD option

7.5.2.3.1 General requirements

The static reference performance as specified in clause 7.2 shall be met with a wanted and an interfering signal coupled to the BS antenna input using the parameters specified in tables 7.6-1B, 7.7-1B, 7.8-1B, 7.6-2B, 7.7-2B or 7.8-2B, respectively.

Table 7.6-1B: Blocking requirements for Wide Area BS in operating bands defined in subclause 4.2 a)

Center frequency of interfering signal	Interfering signal mean power	Wanted signal mean power	Minimum offset of interfering signal	Type of interfering signal
1900 - 1920 MHz, 2010 - 2025 MHz	-40 dBm	-103 dBm	20 MHz	WCDMA signal with one code
1880 - 1900 MHz, 1990 - 2010 MHz, 2025 - 2045 MHz	-40 dBm	-103 dBm	20 MHz	WCDMA signal with one code
1920 - 1980 MHz	-40 dBm	-103 dBm	20 MHz	WCDMA signal with one code
1 - 1880 MHz, 1980 - 1990 MHz, 2045 - 12750 MHz	-15 dBm	-103 dBm	—	CW carrier

Table 7.7-1B: Blocking requirements for Wide Area BS in operating bands defined in subclause 4.2 b)

Center frequency of interfering signal	Interfering signal mean power	Wanted signal mean power	Minimum offset of interfering signal	Type of interfering signal
1850 - 1990 MHz	-40 dBm	-103 dBm	20 MHz	WCDMA signal with one code
1830 - 1850 MHz, 1990 - 2010 MHz	-40 dBm	-103 dBm	20 MHz	WCDMA signal with one code
1 - 1830 MHz, 2010 - 12750 MHz	-15 dBm	-103 dBm	—	CW carrier

Table 7.8-1B: Blocking requirements for Wide Area BS in operating bands defined in subclause 4.2 c)

Center frequency of interfering signal	Interfering signal mean power	Wanted signal mean power	Minimum offset of interfering signal	Type of interfering signal
1910 - 1930 MHz	-40 dBm	-103 dBm	20 MHz	WCDMA signal with one code
1890 - 1910 MHz, 1930 - 1950 MHz	-40 dBm	-103 dBm	20 MHz	WCDMA signal with one code
1 - 1890 MHz, 1950 - 12750 MHz	-15 dBm	-103 dBm	—	CW carrier

Table 7.9-1B: Blocking requirements for Wide Area BS in operating bands defined in subclause 4.2 d)

Centre Frequency of Interfering Signal	Interfering Signal Mean Power	Wanted Signal Mean Power	Minimum Offset of Interfering Signal	Type of Interfering Signal
2570 - 2620 MHz	-40 dBm	-103 dBm	20 MHz	WCDMA signal with one code
2550 - 2570 MHz 2620 - 2640 MHz	-40 dBm	-103 dBm	20 MHz	WCDMA signal with one code
2500 - 2570 MHz 2620 - 2690 MHz	-40 dBm	-103 dBm	20 MHz	WCDMA signal with one code
1 - 2550 MHz, 2690 - 12750 MHz	-15 dBm	-103 dBm	—	CW carrier

Table 7.6-2B: Blocking requirements for Local Area BS in operating bands defined in subclause 4.2 a)

Center frequency of interfering signal	Interfering signal level	Wanted signal level	Minimum offset of interfering signal	Type of interfering signal
1900 - 1920 MHz, 2010 - 2025 MHz	-30 dBm	-89 dBm	20 MHz	WCDMA signal with one code
1880 - 1900 MHz, 1990 - 2010 MHz, 2025 - 2045 MHz	-30 dBm	-89 dBm	20 MHz	WCDMA signal with one code
1920 - 1980 MHz	-30 dBm	-89 dBm	20 MHz	WCDMA signal with one code
1 - 1880 MHz, 1980 - 1990 MHz, 2045 - 12750 MHz	-15 dBm	-89 dBm	—	CW carrier

Table 7.7-2B: Blocking requirements for Local Area BS in operating bands defined in subclause 4.2 b)

Center frequency of interfering signal	Interfering signal level	Wanted signal level	Minimum offset of interfering signal	Type of interfering signal
1850 - 1990 MHz	-30 dBm	-89 dBm	20 MHz	WCDMA signal with one code
1830 - 1850 MHz, 1990 - 2010 MHz	-30 dBm	-89 dBm	20 MHz	WCDMA signal with one code
1 - 1830 MHz, 2010 - 12750 MHz	-15 dBm	-89 dBm	—	CW carrier

Table 7.8-2B: Blocking requirements for Local Area BS in operating bands defined in subclause 4.2 c)

Center frequency of interfering signal	Interfering signal level	Wanted signal level	Minimum offset of interfering signal	Type of interfering signal
1910 - 1930 MHz	-30 dBm	-89 dBm	20 MHz	WCDMA signal with one code
1890 - 1910 MHz, 1930 - 1950 MHz	-30 dBm	-89 dBm	20 MHz	WCDMA signal with one code
1 - 1890 MHz, 1950 - 12750 MHz	-15 dBm	-89 dBm	—	CW carrier

Table 7.9-2B: Blocking requirements for Local Area BS in operating bands defined in subclause 4.2 d)

Centre Frequency of Interfering Signal	Interfering Signal mean power	Wanted Signal mean power	Minimum Offset of Interfering Signal	Type of Interfering Signal
2570 - 2620 MHz	-30 dBm	-89 dBm	20 MHz	WCDMA signal with one code
2550 - 2570 MHz 2620 - 2640 MHz	-30 dBm	-89 dBm	20 MHz	WCDMA signal with one code
2500 - 2570 MHz 2620 - 2690 MHz	-30 dBm	-89 dBm	20 MHz	WCDMA signal with one code
1 - 2550 MHz, 2690 - 12750 MHz	-15 dBm	-89 dBm	—	CW carrier

The normative reference for this requirement is TS 25.105 [1] subclause 7.5.0.3.

7.5.2.3.2 Void

Table 7.9B: Void

Table 7.10F: Void

7.5.2.3.3 Void

Table 7.10G: Void

Table 7.10H: Void

7.5.2.3.4 Co-location with GSM, DCS, UTRA-FDD and/or E-UTRA FDD

This additional blocking requirement may be applied for the protection of TDD BS receivers when GSM, DCS, UTRA - FDD and/or E-UTRA-FDD BTS are co-located with UTRA TDD Wide Area BS.

The blocking performance requirement applies to interfering signals with center frequency within the ranges specified in the tables below, using a 1MHz step size.

In case this additional blocking requirement is applied, the static reference performance as specified in clause 7.2.1 shall be met with a wanted and an interfering signal coupled to BS antenna input using the following parameters.

Table 7.9C: Additional blocking requirements for Wide Area BS in operating bands defined in subclause 4.2 a) and 4.2 d)

System type operating in the same geographic area	Center Frequency of Interfering Signal	Interfering Signal mean power	Wanted Signal mean power	Minimum Offset of Interfering Signal	Type of Interfering Signal	Note
GSM900	921 - 960 MHz	+16 dBm	-103 dBm	—	CW carrier	
DCS1800	1805 - 1880 MHz	+16 dBm	-103 dBm	—	CW carrier	
WA BS UTRA FDD Band VII or E-UTRA Band 7	2620 - 2690 MHz	+13 dBm	-103 dBm	—	CW carrier	This requirement does not apply to UTRA TDD BS operating in Band 5.2(a)
LA BS UTRA FDD Band VII or E-UTRA Band 7	2620 - 2690 MHz	-6 dBm	-103 dBm	—	CW carrier	This requirement does not apply to UTRA TDD BS operating in Band 5.2(a)
NOTE 1: These requirements do not apply when the interfering signal falls within the uplink operating band or in the 10 MHz immediately outside the uplink operating band.						
NOTE 2: Some combinations of bands may not be possible to co-site based on the requirements above. The current state-of-the-art technology does not allow a single generic solution for co-location of UTRA TDD with UTRA FDD or E-UTRA FDD on adjacent frequencies for 30dB BS-BS minimum coupling loss. However, there are certain site-engineering solutions that can be used. These techniques are addressed in TR 25.942 [9].						

7.5.3 Test purpose

7.5.3.1 3,84 Mcps TDD option

The test stresses the ability of the BS receiver to withstand high-level interference from unwanted signals at frequency offsets of 10 MHz or more, without undue degradation of its sensitivity.

7.5.3.2 1,28 Mcps TDD option

The test stresses the ability of the BS receiver to withstand high-level interference from unwanted signals at frequency offsets of 3,2 MHz or more, without undue degradation of its sensitivity.

7.5.3.3 7,68 Mcps TDD option

The test stresses the ability of the BS receiver to withstand high-level interference from unwanted signals at frequency offsets of 20 MHz or more, without undue degradation of its sensitivity.

7.5.4 Method of test

7.5.4.1 Initial conditions

Test environment: normal; see subclause 5.9.1.

RF channels to be tested: M; see subclause 5.3. The BS shall be configured to operate as close to the centre of the operating band as possible.

- (1) Connect an UE simulator operating at the assigned channel frequency of the wanted signal and a signal generator to the antenna connector of one Rx port.
- (2) Terminate or disable any other Rx port not under test.
- (3) Start transmission from the BS tester to the BS using the UL reference measurement channel (12,2 kbps) defined in Annex A.2.1. The level of the UE simulator signal measured at the BS antenna connector shall be set to 6 dB above the reference sensitivity level specified in subclause 7.2.2.

7.5.4.2 Procedure

7.5.4.2.1 3,84 Mcps TDD option

- (1) Set the signal generator to produce an interfering signal at a frequency offset F_{uw} from the assigned channel frequency of the wanted signal which is given by

$$F_{uw} = \pm (n \times 1 \text{ MHz}),$$

where n shall be increased in integer steps from $n = 10$ up to such a value that the center frequency of the interfering signal covers the range from 1 MHz to 12,75 GHz. The interfering signal level measured at the antenna connector shall be set in dependency of its center frequency, as specified in tables 7.6 to 7.10. The type of the interfering signal is either equivalent to a continuous wideband CDMA signal with one code of chip frequency 3,84 Mchip/s, filtered by an RRC transmit pulse-shaping filter with roll-off $\alpha = 0,22$, or a CW signal; see tables 7.6 to 7.10.

- (2) Measure the BER of the wanted signal at the BS receiver.
- (3) Interchange the connections of the BS Rx ports and repeat the measurements according to steps (1) and (2).

7.5.4.2.2 1,28 Mcps TDD option

- (1) Set the signal generator to produce an interfering signal at a frequency offset F_{uw} from the assigned channel frequency of the wanted signal which is given by

$$F_{uw} = \pm (3,2 + n) \times 1 \text{ MHz}$$

where n shall be increased in integer steps from $n = 0$ up to such a value that the center frequency of the interfering signal covers the range from 1 MHz to 12,75 GHz. The interfering signal level measured at the antenna connector shall be set in dependency of its center frequency, as specified in tables 7.6A to 7.10A. The type of the interfering signal is either equivalent to a continuous wideband CDMA signal with one code of chip frequency 1,28 Mchip/s, filtered by an RRC transmit pulse-shaping filter with roll-off $\alpha = 0,22$, or a CW signal; see tables 7.6A to 7.10A.

- (2) Measure the BER of the wanted signal at the BS receiver.
- (3) Interchange the connections of the BS Rx ports and repeat the measurements according to steps (1) and (2).

7.5.4.2.3 7,68 Mcps TDD option

- (1) Set the signal generator to produce an interfering signal at a frequency offset F_{uw} from the assigned channel frequency of the wanted signal which is given by

$$F_{uw} = \pm (n \times 1 \text{ MHz}),$$

where n shall be increased in integer steps from $n = 20$ up to such a value that the center frequency of the interfering signal covers the range from 1 MHz to 12,75 GHz. The interfering signal level measured at the antenna connector shall be set in dependency of its center frequency, as specified in tables 7.6B to 7.10F. The type of the interfering signal is either equivalent to a continuous wideband CDMA signal with one code of chip frequency 7,68 Mchip/s, filtered by an RRC transmit pulse-shaping filter with roll-off $\alpha = 0,22$, or a CW signal; see subclause tables 7.6B to 7.10F.

- (2) Measure the BER of the wanted signal at the BS receiver.

(3) Interchange the connections of the BS Rx ports and repeat the measurements according to steps (1) and (2).

7.5.5 Test Requirements

NOTE 1: If the Test Requirement below differs from the Minimum Requirement, then the Test Tolerance applied for this test is non-zero. The Test Tolerance for this test is defined in subclause 5.11 and the explanation of how the Minimum Requirement has been relaxed by the Test Tolerance is given in Annex D.

In all measurements made according to subclause 7.5.4.2, the BER shall not exceed 0,001.

NOTE 2: Annex F describes the procedure for BER tests taking into account the statistical consequence of frequent repetition of BER measurements within the blocking test. The consequence is: a DUT exactly on the limit may fail due to the statistical nature 2.55 times (mean value) in 12750 BER measurements using the predefined wrong decision probability of 0.02%. If the fail cases are ≤ 12 , it is allowed to repeat the fail cases 1 time before the final verdict.

7.6 Intermodulation characteristics

7.6.1 Definition and applicability

Third and higher order mixing of two interfering RF signals can produce an interfering signal in the band of the desired channel. Intermodulation response rejection is a measure of the capability of the receiver to receive a wanted signal on its assigned channel frequency in the presence of two or more interfering signals which have a specific frequency relationship to the wanted signal.

In this subclause, different requirements shall apply to Wide Area BS and Local Area BS.

7.6.2 Minimum Requirements

7.6.2.1 3,84 Mcps TDD option

The static reference performance as specified in clause 7.2 should be met when the following signals are coupled to the BS antenna input.

- A wanted signal at the assigned channel frequency, with mean power 6 dB above the static reference level.
- Two interfering signals with the parameters specified in table 7.11.

Table 7.11: Parameters of the interfering signals for intermodulation characteristics testing

Interfering Signal mean power		Offset	Type of Interfering Signal
Wide Area BS	Local Area BS		
- 48 dBm	- 38 dBm	10 MHz	CW signal
- 48 dBm	- 38 dBm	20 MHz	WCDMA signal with one code

The normative reference for this requirement is TS 25.105 [1] subclause 7.6.1.1.

7.6.2.2 1,28 Mcps TDD option

The static reference performance as specified in clause 7.2 should be met when the following signals are coupled to the BS antenna input.

- A wanted signal at the assigned channel frequency, with mean power 6 dB above the static reference level.
- Two interfering signals with the parameters specified in table 7.11A.

Table 7.11A: Parameters of the interfering signals for intermodulation characteristics testing for 1,28 Mcps TDD

Interfering Signal mean power		Offset	Type of Interfering Signal
Wide Area BS	Local Area BS / Home BS		
- 48 dBm	- 38 dBm	±3,2 MHz	CW signal
- 48 dBm	- 38 dBm	±6,4 MHz	1,28 Mcps TDD signal with one code

The normative reference for this requirement is TS 25.105 [1] subclause 7.6.1.2.

7.6.2.3 7,68 Mcps TDD option

The static reference performance as specified in clause 7.2 should be met when the following signals are coupled to the BS antenna input.

- A wanted signal at the assigned channel frequency, with mean power 6 dB above the static reference level.
- Two interfering signals with the parameters specified in table 7.11B.

Table 7.11B: Parameters of the interfering signals for intermodulation characteristics testing

Interfering Signal mean power		Offset	Type of Interfering Signal
Wide Area BS	Local Area BS		
- 48 dBm	- 38 dBm	20 MHz	CW signal
- 48 dBm	- 38 dBm	40 MHz	WCDMA signal with one code

The normative reference for this requirement is subclause 7.6.1.3.

7.6.3 Test purpose

The test purpose is to verify the ability of the BS receiver to inhibit the generation of intermodulation products in its non-linear elements caused by the presence of two high-level interfering signals at frequencies with a specific relationship to the frequency of the wanted signal.

7.6.4 Method of test

7.6.4.1 Initial conditions

7.6.4.1.1 3,84 Mcps TDD option

Test environment: normal; see subclause 5.9.1.

RF channels to be tested: B, M and T; see subclause 5.3.

- (1) Connect an UE simulator operating at the assigned channel frequency of the wanted signal and two signal generators to the antenna connector of one Rx port.
- (2) Terminate or disable any other Rx port not under test.
- (3) Start transmission from the BS tester to the BS using the UL reference measurement channel (12,2 kbps) defined in Annex A.2.1. The level of the UE simulator signal measured at the BS antenna connector shall be set to 6 dB above the reference sensitivity level specified in subclause 7.2.2.
- (4) Set the first signal generator to produce a CW signal with a level measured at the BS antenna connector as specified in table 7.11..
- (5) Set the second signal generator to produce an interfering signal equivalent to a wideband CDMA signal with one code of chip frequency 3,84 MHz, filtered by an RRC transmit pulse-shaping filter with roll-off $\alpha = 0,22$. The level of the signal measured at the BS antenna connector shall be set as specified in table 7.11.

7.6.4.1.2 1,28 Mcps TDD option

Test environment: normal; see subclause 5.9.1.

RF channels to be tested: B, M and T; see subclause 5.3.

- (1) Connect an UE simulator operating at the assigned channel frequency of the wanted signal and two signal generators to the antenna connector of one Rx port.
- (2) Terminate or disable any other Rx port not under test.
- (3) Start transmission from the BS tester to the BS using the UL reference measurement channel (12,2 kbps) defined in Annex A.2.1. The level of the UE simulator signal measured at the BS antenna connector shall be set to 6 dB above the reference sensitivity level specified in subclause 7.2.2.
- (4) Set the first signal generator to produce a CW signal with a level measured at the BS antenna connector as specified in table 7.11A.
- (5) Set the second signal generator to produce an interfering signal equivalent to a wideband CDMA signal with one code of chip frequency 1,28 MHz, filtered by an RRC transmit pulse-shaping filter with roll-off $\alpha = 0,22$. The level of the signal measured at the BS antenna connector shall be set as specified in table 7.11A.

7.6.4.1.3 7,68 Mcps TDD option

Test environment: normal; see subclause 5.9.1.

RF channels to be tested: B, M and T; see subclause 5.3.

- (1) Connect an UE simulator operating at the assigned channel frequency of the wanted signal and two signal generators to the antenna connector of one Rx port.
- (2) Terminate or disable any other Rx port not under test.
- (3) Start transmission from the BS tester to the BS using the UL reference measurement channel (12,2 kbps) defined in Annex A.2.1. The level of the UE simulator signal measured at the BS antenna connector shall be set to 6 dB above the reference sensitivity level specified in subclause 7.2.2.
- (4) Set the first signal generator to produce a CW signal with a level measured at the BS antenna connector as specified in table 7.11B.
- (5) Set the second signal generator to produce an interfering signal equivalent to a wideband CDMA signal with one code of chip frequency 7,68 MHz, filtered by an RRC transmit pulse-shaping filter with roll-off $\alpha = 0,22$. The level of the signal measured at the BS antenna connector shall be set as specified in table 7.11B.

7.6.4.2 Procedure

7.6.4.2.1 3,84 Mcps TDD option

- (1) The frequency of the first and the second signal generator shall be set to 10 MHz and 20 MHz, respectively, above the assigned channel frequency of the wanted signal.
- (2) Measure the BER of the wanted signal at the BS receiver.
- (3) The frequency of the first and the second signal generator shall be set to 10 MHz and 20 MHz, respectively, below the assigned channel frequency of the wanted signal.
- (4) Measure the BER of the wanted signal at the BS receiver.
- (5) Interchange the connections of the BS Rx ports and repeat the measurements according to steps (1) to (4).

7.6.4.2.2 1,28 Mcps TDD option

- (1) The frequency of the first and the second signal generator shall be set to 3,2 MHz and 6,4 MHz, respectively, above the assigned channel frequency of the wanted signal.

- (2) Measure the BER of the wanted signal at the BS receiver.
- (3) The frequency of the first and the second signal generator shall be set to 3,2 MHz and 6,4 MHz, respectively, below the assigned channel frequency of the wanted signal.
- (4) Measure the BER of the wanted signal at the BS receiver.
- (5) Interchange the connections of the BS Rx ports and repeat the measurements according to steps (1) to (4).

7.6.4.2.3 7,68 Mcps TDD option

- (1) The frequency of the first and the second signal generator shall be set to 20 MHz and 40 MHz, respectively, above the assigned channel frequency of the wanted signal.
- (2) Measure the BER of the wanted signal at the BS receiver.
- (3) The frequency of the first and the second signal generator shall be set to 20 MHz and 40 MHz, respectively, below the assigned channel frequency of the wanted signal.
- (4) Measure the BER of the wanted signal at the BS receiver.
- (5) Interchange the connections of the BS Rx ports and repeat the measurements according to steps (1) to (4).

7.6.5 Test Requirements

NOTE: If the Test Requirement below differs from the Minimum Requirement, then the Test Tolerance applied for this test is non-zero. The Test Tolerance for this test is defined in subclause 5.11 and the explanation of how the Minimum Requirement has been relaxed by the Test Tolerance is given in Annex D.

The BER measured according subclause 7.6.4.2 to shall not exceed 0,001.

7.7 Spurious emissions

7.7.1 Definition and applicability

The spurious emissions power is the power of emissions generated or amplified in a receiver that appear at the BS antenna connector. The requirements apply to all BS with separate Rx and Tx antenna connectors. For BS equipped with only a single antenna connector for both transmitter and receiver, the requirements of subclause 6.6.3 shall apply to this port, and this test need not be performed.

The requirements in this subclause shall apply to both Wide Area BS and Local Area BS.

7.7.2 Minimum Requirements

7.7.2.1 3,84 Mcps TDD option

The power of any spurious emission shall not exceed the values given in table 7.12.

Table 7.12: Receiver spurious emission requirements

Band	Maximum level	Measurement Bandwidth	Note
30 MHz - 1 GHz	-57 dBm	100 kHz	
1 GHz - 1,9 GHz	-47 dBm	1 MHz	With the exception of frequencies between 12,5 MHz below the first carrier frequency and 12,5 MHz above the last carrier frequency used by the BS
1,900 - 1,980 GHz	-78 dBm	3,84 MHz	With the exception of frequencies between 12,5 MHz below the first carrier frequency and 12,5 MHz above the last carrier frequency used by the BS
1,980 - 2,010 GHz	-47 dBm	1 MHz	With the exception of frequencies between 12,5 MHz below the first carrier frequency and 12,5 MHz above the last carrier frequency used by the BS
2,010 - 2,025 GHz	-78 dBm	3,84 MHz	With the exception of frequencies between 12,5 MHz below the first carrier frequency and 12,5 MHz above the last carrier frequency used by the BS
2,025 - 2,500 GHz	-47 dBm	1 MHz	With the exception of frequencies between 12,5 MHz below the first carrier frequency and 12,5 MHz above the last carrier frequency used by the BS
2,500 - 2,620	-78 dBm	3,84 MHz	With the exception of frequencies between 12,5 MHz below the first carrier frequency and 12,5 MHz above the last carrier frequency used by the BS
2,620 GHz - 12,75 GHz	-47 dBm	1 MHz	With the exception of frequencies between 12,5 MHz below the first carrier frequency and 12,5 MHz above the last carrier frequency used by the BS

Table 7.12AA: Additional receiver spurious emission requirements

Band	Maximum level	Measurement Bandwidth	Note
815 MHz - 850 MHz 1749.9 MHz - 1784.9 MHz	-78 dBm	3,84 MHz	Applicable in Japan With the exception of frequencies between 12,5 MHz below the first carrier frequency and 12,5 MHz above the last carrier frequency used by the BS

In addition to the requirements in table 7.12 and 7.12AA, the co-existence requirements for co-located base stations in subclauses 6.6.3.2.2.2, 6.6.3.2.3.2 and 6.6.3.2.4.2 may also be applied.

The normative reference for this requirement is TS 25.105 [1] subclause 7.7.1.1.

7.7.2.2 1,28 Mcps TDD option

The power of any spurious emission shall not exceed the values given in table 7.12A.

Table 7.12A: General receiver spurious emission minimum requirements

Band	Maximum level	Measurement Bandwidth	Note
30MHz - 1 GHz	-57 dBm	100 kHz	
1 GHz - 12.75 GHz	-47 dBm	1 MHz	With the exception of frequencies between 4 MHz below the first carrier frequency and 4 MHz above the last carrier frequency used by the BS.

Table 7.12A-1: Additional spurious emission requirements

Operating Band	Band	Maximum level	Measurement Bandwidth	Note
a	1900 - 1920 MHz	-83 dBm	1.28 MHz	With the exception of frequencies between 4 MHz below the first carrier frequency and 4 MHz above the last carrier frequency used by the BS.
	2010 – 2025 MHz	-83 dBm	1.28 MHz	
b	1850 - 1910 MHz	-83 dBm	1.28 MHz	
	1930 – 1990 MHz	-83 dBm	1.28 MHz	
c	1910 – 1930 MHz	-83 dBm	1.28 MHz	
d	2570 - 2620 MHz	-83 dBm	1.28 MHz	
e	2300 - 2400 MHz	-83 dBm	1.28 MHz	
f	1880 - 1920 MHz	-83 dBm	1.28 MHz	

In addition, the requirement in Table 7.12A-2 may be applied to geographic areas in which both UTRA -TDD and UTRA-FDD are deployed.

Table 7.12A-2: Additional spurious emission requirements for the FDD bands

Protected Band	Maximum level	Measurement Bandwidth	Note
1920 - 1980	-78 dBm	3.84 MHz	With the exception of frequencies between 4 MHz below the first carrier frequency and 4 MHz above the last carrier frequency used by the BS.
2500 – 2570 MHz	-78 dBm	3.84 MHz	

In addition, the power of any spurious emission shall not exceed the levels specified for Co-existence with other systems in the same geographical area in subclause 6.6.3.2.2.1 and 6.6.3.5.2.2.2. In addition, the co-existence requirements for co-located base stations specified in subclause 6.6.3.2.5.1.2 and 6.6.3.2.5.2.2 may also be applied.

The normative reference for this requirement is TS 25.105 [1] subclause 7.7.1.2.

7.7.2.3 7,68 Mcps TDD option

The power of any spurious emission shall not exceed the values given in table 7.12B and table7.12BB.

Table 7.12B: Receiver spurious emission requirements

Band	Maximum level	Measurement Bandwidth	Note
30 MHz - 1 GHz	-57 dBm	100 kHz	
1 GHz - 1.9 GHz and 1.98 GHz - 2.01 GHz 2.025 GHz - 2.5 GHz	-47 dBm	1 MHz	With the exception of frequencies between 25MHz below the first carrier frequency and 25MHz above the last carrier frequency used by the BS.
1.9 GHz - 1.98 GHz and 2.01 GHz - 2.025 GHz 2.5 GHz - 2.62 GHz	-75 dBm	7.68 MHz	With the exception of frequencies between 25MHz below the first carrier frequency and 25MHz above the last carrier frequency used by the BS.
2.62 GHz - 12.75 GHz	-47 dBm	1 MHz	With the exception of frequencies between 25MHz below the first carrier frequency and 25MHz above the last carrier frequency used by the BS.

Table 7.12BB: Additional receiver spurious emission requirements

Band	Maximum level	Measurement Bandwidth	Note
815 MHz - 850 MHz 1427.9MHz - 1452.9MHz 1749.9 MHz - 1784.9 MHz	-78 dBm	3,84 MHz	Applicable in Japan With the exception of frequencies between 25MHz below the first carrier frequency and 25MHz above the last carrier frequency used by the BS.

In addition to the requirements in table 7.12B and 7.12BB, the co-existence requirements for co-located base stations specified in subclause 6.6.3.2.2.2, 6.6.3.2.3.2 and 6.6.3.2.4.2 may also be applied.

The normative reference for this requirement is subclause 6.3.7.1.

7.7.3 Test purpose

The test purpose is to verify the ability of the BS to limit the interference caused by receiver spurious emissions to other systems.

7.7.4 Method of test

7.7.4.1 Initial conditions

7.7.4.1.0 General test conditions

Test environment: normal; see subclause 5.9.1.

RF channels to be tested: M; see subclause 5.3.

7.7.4.1.1 3,84 Mcps TDD option

- (1) Connect the measuring equipment to the antenna connector of one BS Rx port.
- (2) Terminate or disable any other BS Rx port not under test.
- (3) Set the BS receiver to operational mode.
- (4) Set the BS to transmit a signal with parameters according to table 7.13.
- (5) Terminate the Tx port(s).

Table 7.13: Parameters of the transmitted signal for Rx spurious emissions test

Parameter	Value/description
TDD Duty Cycle	TS i ; $i = 0, 1, 2, \dots, 14$: transmit, if i is even; receive, if i is odd.
Time slot carrying SCH	TS0
Time slots under test	TS i , i even and non zero
BS output power setting	PRAT
Number of DPCH in each time slot under test	9
Power of each DPCH	1/9 of Base Station output power
Data content of DPCH	real life (sufficient irregular)

7.7.4.1.2 1,28 Mcps TDD option

- (1) Connect the measuring equipment to the antenna connector of one BS Rx port.
- (2) Terminate or disable any other BS Rx port not under test.

- (3) Set the BS receiver to operational mode.
- (4) Set the BS to transmit a signal with parameters according to table 7.13A.
- (5) Terminate the Tx port(s).

Table 7.13A: Parameters of the transmitted signal for Rx spurious emissions test for 1,28 Mcps TDD

Parameter	Value/description
TDD Duty Cycle	TS i ; $i = 0, 1, 2, \dots, 6$: transmit, if i is 0,4,5,6; receive, if i is 1,2,3.
Time slots under test	TS4, TS5 and TS6
BS output power setting	PRAT
Number of DPCH in each time slot under test	8
Power of each DPCH	1/8 of Base Station output power
Data content of DPCH	real life (sufficient irregular)

7.7.4.1.3 7,68 Mcps TDD option

- (1) Connect the measuring equipment to the antenna connector of one BS Rx port.
- (2) Terminate or disable any other BS Rx port not under test.
- (3) Set the BS receiver to operational mode.
- (4) Set the BS to transmit a signal with parameters according to table 7.13B.
- (5) Terminate the Tx port(s).

Table 7.13B: Parameters of the transmitted signal for Rx spurious emissions test

Parameter	Value/description
TDD Duty Cycle	TS i ; $i = 0, 1, 2, \dots, 14$: transmit, if i is even; receive, if i is odd.
Time slot carrying SCH	TS0
Time slots under test	TS i , i even and non zero
BS output power setting	PRAT
Number of DPCH in each time slot under test	9
Power of each DPCH	1/9 of Base Station output power
Data content of DPCH	real life (sufficient irregular)

7.7.4.2 Procedure

7.7.4.2.1 3,84 Mcps TDD option

- (1) Measure the power of the spurious emissions by applying the measuring equipment with the settings as specified in table 7.14. The characteristics of the measurement filter with the bandwidth 3,84 MHz shall be RRC with roll-off $\alpha = 0,22$. The characteristics of the measurement filters with bandwidths 100 kHz and 1 MHz shall be approximately Gaussian (typical spectrum analyzer filter). The center frequency of the filters shall be stepped in contiguous steps over the frequency bands as specified in table 7.14 and table 7.14AA. The time duration of each step shall be sufficiently long to capture one even (transmit) time slot.
- (2) If the BS is equipped with more than one Rx port, interchange the connections of the BS Rx ports and repeat the measurement according to (1).

Table 7.14: Measurement equipment settings

Stepped frequency range	Measurement bandwidth	Step width	Note	Detection mode
30 MHz - 1 GHz	100 kHz	100 kHz	With the exception of frequencies between 12,5 MHz below the first carrier frequency and 12,5 MHz above the last carrier frequency used by the BS	true RMS
1 GHz - 1,900 GHz	1 MHz	1 MHz		
1,900 GHz - 1,980 GHz	3,84 MHz	200 kHz		
1,980 GHz - 2,010 GHz	1 MHz	1 MHz		
2,010 GHz - 2,025 GHz	3,84 MHz	200 kHz		
2,025 GHz - 2,500 GHz	1 MHz	1 MHz		
2,500 GHz - 2,620GHz	3,84 MHz	200 kHz		
2,620 GHz - 12,75 GHz	1 MHz	1 MHz		

Table 7.14 AA: Additional measurement equipment settings

Band	Measurement Bandwidth	Step Width	Note	Detection mode
815 MHz – 850 MHz 1749,9 MHz – 1784,9 MHz	3,84 MHz	200 kHz	Applicable in Japan With the exception of frequencies between 12,5 MHz below the first carrier frequency and 12,5 MHz above the last carrier frequency used by the BS	True RMS

7.7.4.2.2 1,28 Mcps TDD option

- (1) Measure the power of the spurious emissions by applying the measuring equipment with the settings as specified in table 7.14A. The characteristics of the measurement filter with the bandwidth 1,28 MHz shall be RRC with roll-off $\alpha = 0,22$. The characteristics of the measurement filters with bandwidths 100 kHz and 1 MHz shall be approximately Gaussian (typical spectrum analyzer filter). The center frequency of the filters shall be stepped in contiguous steps over the frequency bands as specified in table 7.14A. The time duration of each step shall be sufficiently long to capture one even (transmit) time slot.
- (2) If the BS is equipped with more than one Rx port, interchange the connections of the BS Rx ports and repeat the measurement according to (1).

Table 7.14A: Measurement equipment settings

Stepped frequency range	Measurement bandwidth	Step width	Note	Detection mode
30 MHz - 1 GHz	100 kHz	100 kHz	With the exception of frequencies between 4 MHz below the first carrier frequency and 4 MHz above the last carrier frequency used by the BS	true RMS
1 GHz - 1,880 GHz	1 MHz	1 MHz		
1,880 GHz - 1,980 GHz	1,28 MHz	200 kHz		
1,980 GHz - 2,010 GHz	1 MHz	1 MHz		
2,010 GHz - 2,025 GHz	1,28 MHz	200 kHz		
2,025 – 2,300 GHz	1 MHz	1 MHz		
2,300 GHz - 2,400 GHz	1,28 MHz	200 kHz		
2,400 GHz - 2,500 GHz	1 MHz	1 MHz		
2,500 GHz - 2,620GHz	1,28 MHz	200 kHz		
2,620 GHz - 12,75 GHz	1 MHz	1 MHz		

7.7.4.2.3 7,68 Mcps TDD option

- (1) Measure the power of the spurious emissions by applying the measuring equipment with the settings as specified in table 7.14B. The characteristics of the measurement filter with the bandwidth 7,68 MHz shall be RRC with roll-off $\alpha = 0,22$. The characteristics of the measurement filters with bandwidths 100 kHz and 1 MHz shall be approximately Gaussian (typical spectrum analyzer filter). The center frequency of the filters shall be stepped in contiguous steps over the frequency bands as specified in table 7.14B and 7.14BB. The time duration of each step shall be sufficiently long to capture one even (transmit) time slot.
- (2) If the BS is equipped with more than one Rx port, interchange the connections of the BS Rx ports and repeat the measurement according to (1).

Table 7.14B: Measurement equipment settings

Stepped frequency range	Measurement bandwidth	Step width	Note	Detection mode
30 MHz - 1 GHz	100 kHz	100 kHz	With the exception of frequencies between 25 MHz below the first carrier frequency and 25 MHz above the last carrier frequency used by the BS	true RMS
1 GHz - 1,900 GHz	1 MHz	1 MHz		
1,900 GHz - 1,980 GHz	7,68 MHz	200 kHz		
1,980 GHz - 2,010 GHz	1 MHz	1 MHz		
2,010 GHz - 2,025 GHz	7,68 MHz	200 kHz		
2,025 GHz - 12,75 GHz	1 MHz	1 MHz		

Table 7.14 BB: Additional measurement equipment settings

Band	Measurement bandwidth	Step width	Note	Detection mode
815 MHz - 850 MHz 1427.9MHz - 1452.9MHz 1749.9 MHz - 1784.9 MHz	3,84 MHz	200 kHz	Applicable in Japan With the exception of frequencies between 25MHz below the first carrier frequency and 25MHz above the last carrier frequency used by the BS.	true RMS

7.7.5 Test Requirements

NOTE: If the Test Requirement below differs from the Minimum Requirement, then the Test Tolerance applied for this test is non-zero. The Test Tolerance for this test is defined in subclause 5.11 and the explanation of how the Minimum Requirement has been relaxed by the Test Tolerance is given in Annex D.

The spurious emissions measured according to subclause 7.7.4.2 shall not exceed the limits specified in subclause 7.7.2.

8 Performance requirements

8.1 General

Performance requirements for the BS are specified for the measurement channels defined in Annex A and the propagation conditions in Annex B. The requirements only apply to those measurement channels that are supported by the base station. The performance requirements for the high speed train conditions defined in Annex B.3 are optional. All Bit Error Ratio (BER) and Block Error ratio (BLER) measurements shall be carried out according to the general rules for statistical testing defined in ITU-T Recommendation O.153 [10] and Annex F.

Unless stated otherwise, performance requirements apply for a single carrier only. Performance requirements for a BS supporting MC-HSUPA are defined in terms of single carrier requirements.

The characteristics of the white noise source, simulating interference from other cells (I_{oc}), shall comply with the AWGN interferer definition in subclause 5.18.

The requirements only apply to a base station with dual receiver antenna diversity unless otherwise stated. The required \hat{I}_{or}/I_{oc} shall be applied separately at each antenna port.

Table 8.1: Summary of Base Station performance targets

Physical channel	Measurement channel	Static	Multi-path Case 1	Multi-path Case 2**	Multi-path Case 3**	High speed train**
		Performance metric				
DCH	12,2 kbps	BLER < 10 ⁻²	BLER < 10 ⁻²	BLER < 10 ⁻²	BLER < 10 ⁻²	BLER < 10 ⁻²
	64 kbps	BLER < 10 ⁻¹ , 10 ⁻²	BLER < 10 ⁻¹ , 10 ⁻²	BLER < 10 ⁻¹ , 10 ⁻²	BLER < 10 ⁻¹ , 10 ⁻² , 10 ⁻³	BLER < 10 ⁻¹ , 10 ⁻²
	144 kbps	BLER < 10 ⁻¹ , 10 ⁻²	BLER < 10 ⁻¹ , 10 ⁻²	BLER < 10 ⁻¹ , 10 ⁻²	BLER < 10 ⁻¹ , 10 ⁻² , 10 ⁻³	-
	384 kbps	BLER < 10 ⁻¹ , 10 ⁻²	BLER < 10 ⁻¹ , 10 ⁻²	BLER < 10 ⁻¹ , 10 ⁻²	BLER < 10 ⁻¹ , 10 ⁻² , 10 ⁻³	-
*Note: Optional condition, not applicable for all BSs.						
**Note: Not applicable for Home BS						

8.2 Demodulation in static propagation conditions

8.2.1 Demodulation of DCH

8.2.1.1 Definition and applicability

The performance requirement of DCH in static propagation conditions is determined by the maximum Block Error Ratio (BLER) allowed when the receiver input signal is at a specified \hat{I}_{or}/I_{oc} limit. The BLER is calculated for each of the measurement channels supported by the base station.

In this subclause, different requirements shall apply to Wide Area BS, Local Area BS and Home BS.

8.2.1.2 Minimum Requirements

8.2.1.2.1 3,84 Mcps TDD option

For the parameters specified in table 8.2, the BLER should not exceed the piece-wise linear BLER curve specified in table 8.3. These requirements are applicable for TFCS size 16.

Table 8.2: Parameters in static propagation conditions

Parameters	Unit	Test 1	Test 2	Test 3	Test 4	
Number of DPCH _o		6	4	0	0	
$\frac{DPCH_o - E_c}{I_{or}}$	DB	-9	-9,5	-	-	
I _{oc}	Wide Area BS	dBm/3,84 MHz				-89
	Local Area BS	dBm/3,84 MHz				-74
Cell Parameter*						0,1
DPCH Channelization Codes*	C(k,Q)	C(1,8)	C(1,4) C(5,16)	C(1,2) C(9,16)	C(1,2)	
DPCH _o Channelization Codes*	C(k,Q)	C(i,16) 3 ≤ i ≤ 8	C(i,16) 6 ≤ i ≤ 9	-	-	
Information Data Rate	Kbps	12,2	64	144	384	
*Note: Refer to TS 25.223 for definition of channelization codes and cell parameter.						

Table 8.3: Performance requirements in AWGN channel.

Test Number	$\frac{\hat{I}_{or}}{I_{oc}}$ [dB]	BLER
1	-2,0	10^{-2}
2	-0,4	10^{-1}
	-0,1	10^{-2}
3	-0,2	10^{-1}
	0,1	10^{-2}
4	-0,8	10^{-1}
	-0,6	10^{-2}

The normative reference for this requirement is TS 25.105 [1] subclause 8.2.1.1.1.

8.2.1.2.2 1,28 Mcps TDD option

For the parameters specified in table 8.2A, the BLER should not exceed the piece-wise linear BLER curve specified in table 8.3A. These requirements are applicable for TFCS size 16.

Table 8.2A: Parameters in static propagation conditions for 1,28 Mcps TDD

Parameters		Unit	Test 1	Test 2	Test 3	Test 4
Number of DPCH _o			4	1	1	0
Spread factor of DPCH _o			8	8	8	
$\frac{DPCH_{o-E_c}}{I_{or}}$		dB	-7	-7	-7	-
I _{oc}	Wide Area BS	dBm/1,28 MHz	-91			
	Local Area BS	dBm/1,28 MHz	-77			
	Home BS	dBm/1,28 MHz	-82			
Information Data Rate		kbps	12,2	64	144	384

Table 8.3A: Performance requirements in AWGN channel for 1,28 Mcps TDD

Test Number	$\frac{\hat{I}_{or}}{I_{oc}}$ [dB]	BLER
1	0.6	10^{-2}
2	-0.9	10^{-1}
	-0.4	10^{-2}
3	-0.3	10^{-1}
	-0.1	10^{-2}
4	0.6	10^{-1}
	0.8	10^{-2}

The normative reference for this requirement is TS 25.105 [1] subclause 8.2.1.1.2.

8.2.1.2.3 7,68 Mcps TDD option

For the parameters specified in table 8.2B, the BLER should not exceed the piece-wise linear BLER curve specified in table 8.3B. These requirements are applicable for TFCS size 16.

Table 8.2B: Parameters in static propagation conditions

Parameters		Unit	Test 1
Number of DPCH ₀			14
$\frac{DPCH_0 - E_c}{I_{or}}$		dB	-12
I _{oc}	Wide Area BS	dBm/7.68 MHz	-89
	Local Area BS	dBm/7.68 MHz	-74
Cell Parameter*			0,1
DPCH Channelization Codes*		C(k,Q)	C(1, 16)
DPCH ₀ Channelization Codes*		C(k,Q)	C(i, 32) 3 ≤ i ≤ 16
Information Data Rate		kbps	12.2
*Note: Refer to TS 25.223 for definition of channelization codes and cell parameter.			

Table 8.3B: Performance requirements in AWGN channel.

Test Number	$\frac{\hat{I}_{or}}{I_{oc}}$ [dB]	BLER
1	-2.0	10 ⁻²

The normative reference for this requirement is TS 25.105 [1] subclause 8.2.1.1.3.

8.2.1.3 Test purpose

The test purpose is to verify the ability of the BS to receive a prescribed test signal under static propagation conditions with a BLER not exceeding a specified limit. Within the wanted channel, intracell interference sources as well as an additional intercell interference source are taken into account. Therefore, this test - as all other tests in clause 8 - mainly checks the ability of the signal processing part of the receiver to extract the wanted signal from the interfered-with input signal, whereas the tests in clause 7 concentrate on the receiver RF part.

8.2.1.4 Method of test

8.2.1.4.1 Initial conditions

8.2.1.4.1.0 General test conditions

Test environment: normal; see subclause 5.9.1.

RF channels to be tested: B, M and T; see subclause 5.3.

8.2.1.4.1.1 3,84 Mcps TDD option

Connect the BS tester (UE simulator) generating the wanted signal and a set of interference generators to both BS antenna connectors for diversity reception via a combining network. The set of interference generators comprises a number of CDMA generators, each representing an individual intracell interferer (subsequently called DPCH₀ generators), and an additional band-limited white noise source, simulating interference from other cells. Each DPCH₀ generator shall produce an interfering signal that is equivalent to a valid UTRA TDD signal with spreading factor 16, using the same time slot(s) than the wanted signal and applying the same cell-specific scrambling code. The number of the DPCH₀ generators used in each test is given in table 8.2.

8.2.1.4.1.2 1,28 Mcps TDD option

Connect the BS tester (UE simulator) generating the wanted signal and a set of interference generators to both BS antenna connectors for diversity reception via a combining network. The set of interference generators comprises a number of CDMA generators, each representing an individual intracell interferer (subsequently called DPCH₀

generators), and an additional band-limited white noise source, simulating interference from other cells. Each DPCH₀ generator shall produce an interfering signal that is equivalent to a valid UTRA TDD signal with spreading factor 8, using the same time slot(s) than the wanted signal and applying the same cell-specific scrambling code. The number of the DPCH₀ generators used in each test is given in table 8.2A.

8.2.1.4.1.3 7,68 Mcps TDD option

Connect the BS tester (UE simulator) generating the wanted signal and a set of interference generators to both BS antenna connectors for diversity reception via a combining network. The set of interference generators comprises a number of CDMA generators, each representing an individual intracell interferer (subsequently called DPCH₀ generators), and an additional band-limited white noise source, simulating interference from other cells. Each DPCH₀ generator shall produce an interfering signal that is equivalent to a valid UTRA TDD signal with spreading factor 32, using the same time slot(s) than the wanted signal and applying the same cell-specific scrambling code. The number of the DPCH₀ generators used in each test is given in table 8.2B.

8.2.1.4.2 Procedure

8.2.1.4.2.1 3,84 Mcps TDD option

- (1) Adjust the power of the band-limited white noise source in such a way that its power spectral density measured at the BS antenna connector takes on the value I_{oc} as specified in table 8.2.
- (2) For a given test defined by the information data rate and the BLER objective, set the power of each DPCH₀ measured at the BS antenna connector during the active time slots to the value specified in table 8.4.
- (3) Set up a call between the BS tester generating the wanted signal and the BS. The characteristics of the call shall be configured according to the information data rate to be provided and the corresponding UL reference measurement channel defined in Annex A. Depending on the information data rate, the UL reference measurement channel makes use of one or two Dedicated Physical Channels (DPCH₁ and DPCH₂) with different spreading factors SF. The power(s) of DPCH₁ and DPCH₂ (if applicable) measured at the BS antenna connector during the active time slots shall be set to the value(s) given in table 8.4.
- (4) Measure the BLER of the wanted signal at the BS receiver.

Table 8.4: Parameters of DPCH₀ and the wanted signal

Test Number	BLER objective	Number of DPCH ₀	Power of each DPCH ₀ measured at the BS antenna connector [dBm]		Parameters of the wanted signal			
			Wide Area BS	Local Area BS	DPCH	SF	Power measured at the BS antenna connector [dBm]	
							Wide Area BS	Local Area BS
1	10 ⁻²	6	-100,0	-85	DPCH ₁	8	-97,0	-82,0
2	10 ⁻¹	4	-98,9	-83,9	DPCH ₁	16	-98,9	-83,9
					DPCH ₂	4	-92,9	-77,9
	10 ⁻²	4	-98,6	-83,6	DPCH ₁	16	-98,6	-83,6
					DPCH ₂	4	-92,6	-77,6
3	10 ⁻¹	0	-	-	DPCH ₁	16	-98,7	-83,7
					DPCH ₂	2	-89,7	-74,7
	10 ⁻²	0	-	-	DPCH ₁	16	-98,4	-83,4
DPCH ₂					2	-89,4	-74,4	
4	10 ⁻¹	0	-	-	DPCH ₁	2	-89,8	-74,8
	10 ⁻²	0	-	-	DPCH ₁	2	-89,6	-74,6

8.2.1.4.2.2 1,28 Mcps TDD option

- (1) Adjust the power of the band-limited white noise source in such a way that its power spectral density measured at the BS antenna connector takes on the value I_{oc} as specified in table 8.2A.
- (2) For a given test defined by the information data rate and the BLER objective, set the power of each DPCH₀ measured at the BS antenna connector during the active time slots to the value specified in table 8.4A.

- (3) Set up a call between the BS tester generating the wanted signal and the BS. The characteristics of the call shall be configured according to the information data rate to be provided and the corresponding UL reference measurement channel defined in Annex A. Depending on the information data rate, the UL reference measurement channel makes use of one or two Dedicated Physical Channels (DPCH₁ and DPCH₂) with different spreading factors SF. The power(s) of DPCH₁ and DPCH₂ (if applicable) measured at the BS antenna connector during the active time slots shall be set to the value(s) given in table 8.4A.
- (4) Measure the BLER of the wanted signal at the BS receiver.

Table 8.4A: Parameters of DPCH₀ and the wanted signal for 1,28 Mcps TDD

Test Number	BLER objective	Number of DPCH ₀	Power of each DPCH ₀ measured at the BS antenna connector [dBm]			Parameters of the wanted signal				
			Wide Area BS	Local Area BS	Home BS	DPCH	SF	Power measured at the BS antenna connector [dBm]		
								Wide Area BS	Local Area BS	Home BS
1	10 ⁻²	4	-97.4	-83.4	-88.4	DPCH ₁	8	-97.4	-83.4	-88.4
2	10 ⁻¹	1	-98.9	-84.9	-89.9	DPCH ₁	2	-92.9	-78.9	-83.9
	10 ⁻²	1	-98.4	-84.4	-89.4	DPCH ₁	2	-92.5	-78.5	-83.5
3	10 ⁻¹	1	-98.3	-84.3	-89.3	DPCH ₁	2	-92.3	-78.3	-83.3
	10 ⁻²	1	-98.1	-84.1	-89.1	DPCH ₁	2	-92.1	-78.1	-83.1
4	10 ⁻¹	0	-	-		DPCH ₁	16	-99.9	-85.9	-90.9
						DPCH ₂	2	-90.9	-76.9	-81.9
	10 ⁻²	0	-	-		DPCH ₁	16	-99.7	-85.7	-90.7
						DPCH ₂	2	-90.7	-76.7	-81.7

8.2.1.4.2.3 7,68 Mcps TDD option

- (1) Adjust the power of the band-limited white noise source in such a way that its power spectral density measured at the BS antenna connector takes on the value I_{oc} as specified in table 8.2B.
- (2) For a given test defined by the information data rate and the BLER objective, set the power of each DPCH₀ measured at the BS antenna connector during the active time slots to the value specified in table 8.4B.
- (3) Set up a call between the BS tester generating the wanted signal and the BS. The characteristics of the call shall be configured according to the information data rate to be provided and the corresponding UL reference measurement channel defined in Annex A. Depending on the information data rate, the UL reference measurement channel makes use of one or two Dedicated Physical Channels (DPCH₁ and DPCH₂) with different spreading factors SF. The power(s) of DPCH₁ and DPCH₂ (if applicable) measured at the BS antenna connector during the active time slots shall be set to the value(s) given in table 8.4B.
- (4) Measure the BLER of the wanted signal at the BS receiver.

Table 8.4B: Parameters of DPCH₀ and the wanted signal

Test Number	BLER objective	Number of DPCH ₀	Power of each DPCH ₀ measured at the BS antenna connector [dBm]		Parameters of the wanted signal			
			Wide Area BS	Local Area BS	DPCH	SF	Power measured at the BS antenna connector [dBm]	
							Wide Area BS	Local Area BS
1	10 ⁻²	14	-103,0	-88	DPCH ₁	16	-100,0	-85,0

8.2.1.5 Test Requirements

NOTE: If the Test Requirement below differs from the Minimum Requirement, then the Test Tolerance applied for this test is non-zero. The Test Tolerance for this test is defined in subclause 5.11 and the explanation of how the Minimum Requirement has been relaxed by the Test Tolerance is given in Annex D.

8.2.1.5.1 3,84 Mcps TDD option

The BLER measured according to subclause 8.2.1.4.2 shall not exceed the limits specified in table 8.3.

8.2.1.5.2 1,28 Mcps TDD option

The BLER measured according to subclause 8.2.1.4.2. shall not exceed the limits specified in table 8.3A.

8.2.1.5.3 7,68 Mcps TDD option

The BLER measured according to subclause 8.2.1.4.2 shall not exceed the limits specified in table 8.3B.

8.3 Demodulation of DCH in multipath fading conditions

8.3.1 Multipath fading Case 1

8.3.1.1 Definition and applicability

The performance requirement of DCH in multipath fading Case 1 is determined by the maximum Block Error Ratio (BLER) allowed when the receiver input signal is at a specified \hat{I}_{or}/I_{oc} limit. The BLER is calculated for each of the measurement channels supported by the base station.

In this subclause, different requirements shall apply to Wide Area BS, Local Area BS and Home BS.

8.3.1.2 Minimum Requirements

8.3.1.2.1 3,84 Mcps TDD option

For the parameters specified in table 8.5, the BLER should not exceed the piece-wise linear BLER curve specified in table 8.6. These requirements are applicable for TFCS size 16.

Table 8.5: Parameters in multipath Case 1 channel

Parameters		Unit	Test 1	Test 2	Test 3	Test 4
Number of DPCH _o			6	4	0	0
$\frac{DPCH_o - E_c}{I_{or}}$		dB	-9	-9,5	-	-
I _{oc}	Wide Area BS	dBm/3,84 MHz	-89			
	Local Area BS	dBm/3,84 MHz	-74			
Cell Parameter*			0,1			
DPCH Channelization Codes*		C(k,Q)	C(1,8)	C(1,4) C(5,16)	C(1,2) C(9,16)	C(1,2)
DPCH _o Channelization Codes*		C(k,Q)	C(i,16) 3 ≤ i ≤ 8	C(i,16) 6 ≤ i ≤ 9	-	-
Information Data Rate		Kbps	12,2	64	144	384
*Note: Refer to TS 25.223 for definition of channelization codes and cell parameter.						

Table 8.6: Performance requirements in multipath Case 1 channel.

Test Number	$\frac{\hat{I}_{or}}{I_{oc}}$ [dB]	BLER
1	6,5	10^{-2}
2	5,5	10^{-1}
	9,8	10^{-2}
3	5,5	10^{-1}
	9,8	10^{-2}
4	5,1	10^{-1}
	9,5	10^{-2}

The normative reference for this requirement is TS 25.105 [1] subclause 8.3.1.1.1.

8.3.1.2.2 1,28 Mcps TDD option

For the parameters specified in table 8.5A, the BLER should not exceed the piece-wise linear BLER curve specified in table 8.6A. These requirements are applicable for TFCS size 16.

Table 8.5A: Parameters in multipath Case 1 channel for 1,28 Mcps TDD

Parameters		Unit	Test 1	Test 2	Test 3	Test 4
Number of DPCH _o			4	1	1	0
Spread factor of DPCH _o			8	8	8	
$\frac{DPCH_{o-E_c}}{I_{or}}$		dB	-7	-7	-7	-
I _{oc}	Wide Area BS	dBm/1,28 MHz	-91			
	Local Area BS	dBm/1,28 MHz	-77			
	Home BS	dBm/1,28 MHz	-82			
Information Data Rate		kbps	12,2	64	144	384

Table 8.6A: Performance requirements multipath Case 1 channel for 1,28 Mcps TDD

Test Number	$\frac{\hat{I}_{or}}{I_{oc}}$ [dB]	BLER
1	10.4	10^{-2}
2	5.3	10^{-1}
	9.4	10^{-2}
3	5.7	10^{-1}
	10.1	10^{-2}
4	6.8	10^{-1}
	10.9	10^{-2}

The normative reference for this requirement is TS 25.105 [1] subclause 8.3.1.1.2.

8.3.1.2.3 7,68 Mcps TDD option

For the parameters specified in table 8.5B, the BLER should not exceed the piece-wise linear BLER curve specified in table 8.6B. These requirements are applicable for TFCS size 16.

Table 8.5B: Parameters in multipath Case 1 channel

Parameters		Unit	Test 1
Number of DPCH _o			14
$\frac{DPCH_o - E_c}{I_{or}}$		dB	-12
I _{oc}	Wide Area BS	dBm/7.68 MHz	-89
	Local Area BS	dBm/7.68 MHz	-74
Cell Parameter*			0,1
DPCH Channelization Codes*		C(k,Q)	C(1, 16)
DPCH _o Channelization Codes*		C(k,Q)	C(i, 32) 3 ≤ i ≤ 16
Information Data Rate		Kbps	12.2
*Note: Refer to TS 25.223 for definition of channelization codes and cell parameter.			

Table 8.6B: Performance requirements in multipath Case 1 channel.

Test Number	$\frac{\hat{I}_{or}}{I_{oc}}$ [dB]	BLER
1	6.5	10 ⁻²

The normative reference for this requirement is TS 25.105 [1] subclause 8.3.1.1.3.

8.3.1.3 Test purpose

The test purpose is to verify the ability of the BS to receive a prescribed test signal under defined propagation conditions (multipath fading Case 1) with a BLER not exceeding a specified limit. Within the wanted channel, independent intracell interference sources as well as an additional intercell interference source are taken into account. Therefore, this test - as all other tests in clause 8 - mainly checks the ability of the signal processing part of the receiver to extract the wanted signal from the distorted and interfered-with input signal, whereas the tests in clause 7 concentrate on the receiver RF part.

8.3.1.4 Method of test

8.3.1.4.1 Initial conditions

8.3.1.4.1.0 General test conditions

Test environment: normal; see subclause 5.9.1.

RF channels to be tested: B, M and T; see subclause 5.3.

8.3.1.4.1.1 3,84 Mcps TDD option

- (1) Connect the BS tester (UE simulator) generating the wanted signal and a set of interference generators to both BS antenna connectors for diversity reception via a combining network. The set of interference generators comprises a number of CDMA generators, each representing an individual intracell interferer (subsequently called DPCH_o generators), and an additional band-limited white noise source, simulating interference from other cells. Each DPCH_o generator shall produce an interfering signal that is equivalent to a valid UTRA TDD signal with spreading factor 16, using the same time slot(s) than the wanted signal and applying the same cell-specific scrambling code. The number of the DPCH_o generators used in each test is given in table 8.5.
- (2) The wanted signal produced by the BS tester and the interfering signals produced by the DPCH_o generators are individually passed through independent Multipath Fading Simulators (MFS) before entering the combining network. Each MFS shall be configured to simulate multipath fading Case 1.

8.3.1.4.1.2 1,28 Mcps TDD option

- (1) Connect the BS tester (UE simulator) generating the wanted signal and a set of interference generators to both BS antenna connectors for diversity reception via a combining network. The set of interference generators comprises a number of CDMA generators, each representing an individual intracell interferer (subsequently called DPCH₀ generators), and an additional band-limited white noise source, simulating interference from other cells. Each DPCH₀ generator shall produce an interfering signal that is equivalent to a valid UTRA TDD signal with spreading factor 8, using the same time slot(s) than the wanted signal and applying the same cell-specific scrambling code. The number of the DPCH₀ generators used in each test is given in table 8.5A.
- (2) The wanted signal produced by the BS tester and the interfering signals produced by the DPCH₀ generators are individually passed through independent Multipath Fading Simulators (MFS) before entering the combining network. Each MFS shall be configured to simulate multipath fading Case 1.

8.3.1.4.1.3 7,68 Mcps TDD option

- (1) Connect the BS tester (UE simulator) generating the wanted signal and a set of interference generators to both BS antenna connectors for diversity reception via a combining network. The set of interference generators comprises a number of CDMA generators, each representing an individual intracell interferer (subsequently called DPCH₀ generators), and an additional band-limited white noise source, simulating interference from other cells. Each DPCH₀ generator shall produce an interfering signal that is equivalent to a valid UTRA TDD signal with spreading factor 32, using the same time slot(s) than the wanted signal and applying the same cell-specific scrambling code. The number of the DPCH₀ generators used in each test is given in table 8.5B.
- (2) The wanted signal produced by the BS tester and the interfering signals produced by the DPCH₀ generators are individually passed through independent Multipath Fading Simulators (MFS) before entering the combining network. Each MFS shall be configured to simulate multipath fading Case 1.

8.3.1.4.2 Procedure

8.3.1.4.2.1 3,84 Mcps TDD option

- (1) Adjust the power of the band-limited white noise source in such a way that its power spectral density measured at the BS antenna connector takes on the value I_{oc} as specified in table 8.5.
- (2) For a given test defined by the information data rate and the BLER objective, set the power of each DPCH₀ measured at the BS antenna connector during the active time slots to the value specified in table 8.7.
- (3) Set up a call between the BS tester generating the wanted signal and the BS. The characteristics of the call shall be configured according to the information data rate to be provided and the corresponding UL reference measurement channel defined in Annex A. Depending on the information data rate, the UL reference measurement channel makes use of one or two Dedicated Physical Channels (DPCH₁ and DPCH₂) with different spreading factors SF. The power(s) of DPCH₁ and DPCH₂ (if applicable) measured at the BS antenna connector during the active time slots shall be set to the value(s) given in table 8.7.
- (4) Measure the BLER of the wanted signal at the BS receiver.

Table 8.7: Parameters of DPCH₀ and the wanted signal

Test Number	BLER objective	Number of DPCH ₀	Power of each DPCH ₀ measured at the BS antenna connector [dBm]		Parameters of the wanted signal			
			Wide Area BS	Local Area BS	DPCH	SF	Power measured at the BS antenna connector [dBm]	
							Wide Area BS	Local Area BS
1	10 ⁻²	6	-91,5	-76,5	DPCH ₁	8	-88,5	-73,5
2	10 ⁻¹	4	-93,0	-78,0	DPCH ₁	16	-93,0	-78,0
					DPCH ₂	4	-87,0	-72,0
	10 ⁻²	4	-88,7	-73,7	DPCH ₁	16	-88,7	-73,7
					DPCH ₂	4	-82,7	-67,7
3	10 ⁻¹	0	-	-	DPCH ₁	16	-93,0	-78,0
					DPCH ₂	2	-84,0	-69,0
	10 ⁻²	0	-	-	DPCH ₁	16	-88,7	-73,7
					DPCH ₂	2	-79,7	-64,7
4	10 ⁻¹	0	-	-	DPCH ₁	2	-83,9	-68,9
	10 ⁻²	0	-	-	DPCH ₁	2	-79,5	-64,5

8.3.1.4.2.2 1,28 Mcps TDD option

- (1) Adjust the power of the band-limited white noise source in such a way that its power spectral density measured at the BS antenna connector takes on the value I_{oc} as specified in table 8.5A.
- (2) For a given test defined by the information data rate and the BLER objective, set the power of each DPCH₀ measured at the BS antenna connector during the active time slots to the value specified in table 8.7A.
- (3) Set up a call between the BS tester generating the wanted signal and the BS. The characteristics of the call shall be configured according to the information data rate to be provided and the corresponding UL reference measurement channel defined in Annex A. Depending on the information data rate, the UL reference measurement channel makes use of one or two Dedicated Physical Channels (DPCH₁ and DPCH₂) with different spreading factors SF. The power(s) of DPCH₁ and DPCH₂ (if applicable) measured at the BS antenna connector during the active time slots shall be set to the value(s) given in table 8.7A.
- (4) Measure the BLER of the wanted signal at the BS receiver.

Table 8.7A: Parameters of DPCH₀ and the wanted signal for 1,28 Mcps TDD

Test Number	BLER objective	Number of DPCH ₀	Power of each DPCH ₀ measured at the BS antenna connector [dBm]			Parameters of the wanted signal				
			Wide Area BS	Local Area BS	Home BS	DPCH	SF	Power measured at the BS antenna connector [dBm]		
								Wide Area BS	Local Area BS	Home BS
1	10 ⁻²	4	-87.6	-73,6	-78.6	DPCH ₁	8	-87.6	-73,6	-78.6
2	10 ⁻¹	1	-92.7	-78,7	-83.7	DPCH ₁	2	-86.7	-72,7	-77.7
	10 ⁻²	1	-88.6	-74,6	-79.6	DPCH ₁	2	-82.6	-68,6	-73.6
3	10 ⁻¹	1	-92.3	-78,3	-83.3	DPCH ₁	2	-86.3	-72,3	-77.3
	10 ⁻²	1	-87.9	-73,9	-78.9	DPCH ₁	2	-81.9	-67,9	-72.9
4	10 ⁻¹	0	-			DPCH ₁	16	-93.7	-79,7	-84.7
						DPCH ₂	2	-84.7	-70,7	-75.7
	10 ⁻²	0	-			DPCH ₁	16	-89.6	-75,6	-80.6
						DPCH ₂	2	-80.6	-66,6	-71.6

8.3.1.4.2.3 7,68 Mcps TDD option

- (1) Adjust the power of the band-limited white noise source in such a way that its power spectral density measured at the BS antenna connector takes on the value I_{oc} as specified in table 8.5B.

- (2) For a given test defined by the information data rate and the BLER objective, set the power of each DPCH₀ measured at the BS antenna connector during the active time slots to the value specified in table 8.7B.
- (3) Set up a call between the BS tester generating the wanted signal and the BS. The characteristics of the call shall be configured according to the information data rate to be provided and the corresponding UL reference measurement channel defined in Annex A. Depending on the information data rate, the UL reference measurement channel makes use of one or two Dedicated Physical Channels (DPCH₁ and DPCH₂) with different spreading factors SF. The power(s) of DPCH₁ and DPCH₂ (if applicable) measured at the BS antenna connector during the active time slots shall be set to the value(s) given in table 8.7B.
- (4) Measure the BLER of the wanted signal at the BS receiver.

Table 8.7B: Parameters of DPCH₀ and the wanted signal

Test Number	BLER objective	Number of DPCH ₀	Power of each DPCH ₀ measured at the BS antenna connector [dBm]		Parameters of the wanted signal			
			Wide Area BS	Local Area BS	DPCH	SF	Power measured at the BS antenna connector [dBm]	
							Wide Area BS	Local Area BS
1	10 ⁻²	14	-94,5	-79,5	DPCH ₁	16	-91,5	-76,5

8.3.1.5 Test Requirements

NOTE: If the Test Requirements below differ from the Minimum Requirements, then the Test Tolerance applied for this test is non-zero. The Test Tolerance for this test is defined in subclause 5.1.1 and the explanation of how the Minimum Requirement has been relaxed by the Test Tolerance is given in Annex D.

8.3.1.5.1 3,84 Mcps TDD option

The BLER measured according to subclause 8.3.1.4.2 shall not exceed the limits specified in table 8.6.

8.3.1.5.2 1,28 Mcps TDD option

The BLER measured according to subclause 8.3.1.4.2 shall not exceed the limits specified in table 8.6A.

8.3.1.5.3 7,68 Mcps TDD option

The BLER measured according to subclause 8.3.1.4.2 shall not exceed the limits specified in table 8.6B.

8.3.2 Multipath fading Case 2

8.3.2.1 Definition and applicability

The performance requirement of DCH in multipath fading Case 2 is determined by the maximum Block Error Ratio (BLER) allowed when the receiver input signal is at a specified \hat{I}_{or}/I_{oc} limit. The BLER is calculated for each of the measurement channels supported by the base station.

The requirements in this subclause shall apply to Wide Area BS only. There is no requirement to test Local Area BS and Home BS in multipath fading Case 2 conditions.

8.3.2.2 Minimum Requirements

8.3.2.2.1 3,84 Mcps TDD option

For the parameters specified in table 8.8, the BLER should not exceed the piece-wise linear BLER curve specified in table 8.8. These requirements are applicable for TFCS size 16.

Table 8.8: Parameters in multipath Case 2 channel

Parameters	Unit	Test 1	Test 2	Test 3	Test 4
Number of DPCH _o		2	0	0	0
$\frac{DPCH_o - E_c}{I_{or}}$	DB	-6	-	-	-
I_{oc}	dBm/3,84 MHz	-89			
Cell Parameter*		0,1			
DPCH Channelization Codes*	C(k,Q)	C(1,8)	C(1,4) C(5,16)	C(1,2) C(9,16)	C(1,2)
DPCH _o Channelization Codes*	C(k,Q)	C(i,16) 3 ≤ i ≤ 4	-	-	-
Information Data Rate	Kbps	12,2	64	144	384

*Note: Refer to TS 25.223 for definition of channelization codes and cell parameter.

Table 8.9: Performance requirements in multipath Case 2 channel.

Test Number	$\frac{\hat{I}_{or}}{I_{oc}}$ [dB]	BLER
1	-0,4	10 ⁻²
2	0,2	10 ⁻¹
	2,5	10 ⁻²
3	3,6	10 ⁻¹
	6,0	10 ⁻²
4	2,8	10 ⁻¹
	5,2	10 ⁻²

The normative reference for this requirement is TS 25.105 [1] subclause 8.3.2.1.1.

8.3.2.2.2 1,28 Mcps option

For the parameters specified in table 8.8A, the BLER should not exceed the piece-wise linear BLER curve specified in table 8.9A. These requirements are applicable for TFCS size 16.

Table 8.8A: Parameters in multipath Case 2 channel for 1,28 Mcps TDD

Parameters	Unit	Test 1	Test 2	Test 3	Test 4
Number of DPCH _o		4	1	1	0
Spread factor of DPCH _o		8	8	8	
$\frac{DPCH_o - E_c}{I_{or}}$	dB	-7	-7	-7	-
I_{oc}	dBm/1,28 MHz	-91			
Information Data Rate	kbps	12,2	64	144	384

Table 8.9A: Performance requirements multipath Case 2 channel for 1,28 Mcps TDD.

Test Number	$\frac{\hat{I}_{or}}{I_{oc}}$ [dB]	BLER
1	6.7	10 ⁻²
2	3.6	10 ⁻¹
	5.9	10 ⁻²
3	4.2	10 ⁻¹
	6.3	10 ⁻²
4	4.8	10 ⁻¹
	7.1	10 ⁻²

The normative reference for this requirement is TS 25.105 [1] subclause 8.3.2.1.2.

8.3.2.2.3 7,68 Mcps TDD option

For the parameters specified in table 8.8B, the BLER should not exceed the piece-wise linear BLER curve specified in table 8.9B. These requirements are applicable for TFCS size 16.

Table 8.8B: Parameters in multipath Case 2 channel

Parameters	Unit	Test 1
Number of DPCH ₀		6
$\frac{DPCH_o - E_c}{I_{or}}$	dB	-9
I_{oc}	dBm/7.68 MHz	-89
Cell Parameter*		0,1
DPCH Channelization Codes*	C(k,Q)	C(1, 16)
DPCH ₀ Channelization Codes*	C(k,Q)	C(i, 32) 3 ≤ i ≤ 8
Information Data Rate	kbps	12.2
*Note: Refer to TS 25.223 for definition of channelization codes and cell parameter.		

Table 8.9B: Performance requirements in multipath Case 2 channel.

Test Number	$\frac{\hat{I}_{or}}{I_{oc}}$ [dB]	BLER
1	1	10 ⁻²

The normative reference for this requirement is TS 25.105 [1] subclause 8.3.2.1.3.

8.3.2.3 Test purpose

The test purpose is to verify the ability of the BS to receive a prescribed test signal under defined propagation conditions (multipath fading Case 2) with a BLER not exceeding a specified limit. Within the wanted channel, independent intracell interference sources as well as an additional intercell interference source are taken into account. Therefore, this test - as all other tests in clause 8 - mainly checks the ability of the signal processing part of the receiver to extract the wanted signal from the distorted and interfered-with input signal, whereas the tests in clause 7 concentrate on the receiver RF part.

8.3.2.4 Method of test

8.3.2.4.1 Initial conditions

8.3.2.4.1.0 General test conditions

Test environment: normal; see subclause 5.9.1.

RF channels to be tested: B, M and T; see subclause 5.3.

8.3.2.4.1.1 3,84 Mcps TDD option

- (1) Connect the BS tester (UE simulator) generating the wanted signal and a set of interference generators to both BS antenna connectors for diversity reception via a combining network. The set of interference generators comprises a number of CDMA generators, each representing an individual intracell interferer (subsequently called DPCH₀ generators), and an additional band-limited white noise source, simulating interference from other cells. Each DPCH₀ generator shall produce an interfering signal that is equivalent to a valid UTRA TDD signal with spreading factor 16, using the same time slot(s) than the wanted signal and applying the same cell-specific scrambling code. The number of the DPCH₀ generators used in each test is given in table 8.8.

- (2) The wanted signal produced by the BS tester and the interfering signals produced by the DPCH₀ generators are individually passed through independent Multipath Fading Simulators (MFS) before entering the combining network. Each MFS shall be configured to simulate multipath fading Case 2.

8.3.2.4.1.2 1,28 Mcps TDD option

- (1) Connect the BS tester (UE simulator) generating the wanted signal and a set of interference generators to both BS antenna connectors for diversity reception via a combining network. The set of interference generators comprises a number of CDMA generators, each representing an individual intracell interferer (subsequently called DPCH₀ generators), and an additional band-limited white noise source, simulating interference from other cells. Each DPCH₀ generator shall produce an interfering signal that is equivalent to a valid UTRA TDD signal with spreading factor 8, using the same time slot(s) than the wanted signal and applying the same cell-specific scrambling code. The number of the DPCH₀ generators used in each test is given in table 8.8A.
- (2) The wanted signal produced by the BS tester and the interfering signals produced by the DPCH₀ generators are individually passed through independent Multipath Fading Simulators (MFS) before entering the combining network. Each MFS shall be configured to simulate multipath fading Case 2.

8.3.2.4.1.3 7,68 Mcps TDD option

- (1) Connect the BS tester (UE simulator) generating the wanted signal and a set of interference generators to both BS antenna connectors for diversity reception via a combining network. The set of interference generators comprises a number of CDMA generators, each representing an individual intracell interferer (subsequently called DPCH₀ generators), and an additional band-limited white noise source, simulating interference from other cells. Each DPCH₀ generator shall produce an interfering signal that is equivalent to a valid UTRA TDD signal with spreading factor 32, using the same time slot(s) than the wanted signal and applying the same cell-specific scrambling code. The number of the DPCH₀ generators used in each test is given in table 8.8B.
- (2) The wanted signal produced by the BS tester and the interfering signals produced by the DPCH₀ generators are individually passed through independent Multipath Fading Simulators (MFS) before entering the combining network. Each MFS shall be configured to simulate multipath fading Case 2.

8.3.2.4.2 Procedure

8.3.2.4.2.1 3,84 Mcps TDD option

- (1) Adjust the power of the band-limited white noise source in such a way that its power spectral density measured at the BS antenna connector takes on the value I_{oc} as specified in table 8.8.
- (2) For a given test defined by the information data rate and the BLER objective, set the power of each DPCH₀ measured at the BS antenna connector during the active time slots to the value specified in table 8.101.
- (3) Set up a call between the BS tester generating the wanted signal and the BS. The characteristics of the call shall be configured according to the information data rate to be provided and the corresponding UL reference measurement channel defined in Annex A. Depending on the information data rate, the UL reference measurement channel makes use of one or two Dedicated Physical Channels (DPCH₁ and DPCH₂) with different spreading factors SF. The power(s) of DPCH₁ and DPCH₂ (if applicable) measured at the BS antenna connector during the active time slots shall be set to the value(s) given in table 8.10.
- (4) Measure the BLER of the wanted signal at the BS receiver.

Table 8.10: Parameters of DPCH₀ and the wanted signal

Test Number	BLER objective	Number of DPCH ₀	Power of each DPCH ₀ measured at the BS antenna connector [dBm]	Parameters of the wanted signal		
				DPCH	SF	Power measured at the BS antenna connector [dBm]
1	10 ⁻²	2	-95,4	DPCH ₁	8	-92,4
2	10 ⁻¹	0	-	DPCH ₁	16	-95,8
				DPCH ₂	4	-89,8
3	10 ⁻²	0	-	DPCH ₁	16	-93,5
				DPCH ₂	4	-87,5
	10 ⁻¹	0	-	DPCH ₁	16	-94,9
				DPCH ₂	2	-85,9
4	10 ⁻¹	0	-	DPCH ₁	16	-92,5
				DPCH ₂	2	-83,5
4	10 ⁻²	0	-	DPCH ₁	2	-86,2
				DPCH ₁	2	-83,8

8.3.2.4.2.2 1,28 Mcps TDD option

- (1) Adjust the power of the band-limited white noise source in such a way that its power spectral density measured at the BS antenna connector takes on the value I_{oc} as specified in table 8.8A.
- (2) For a given test defined by the information data rate and the BLER objective, set the power of each DPCH₀ measured at the BS antenna connector during the active time slots to the value specified in table 8.10A.
- (3) Set up a call between the BS tester generating the wanted signal and the BS. The characteristics of the call shall be configured according to the information data rate to be provided and the corresponding UL reference measurement channel defined in Annex A. Depending on the information data rate, the UL reference measurement channel makes use of one or two Dedicated Physical Channels (DPCH₁ and DPCH₂) with different spreading factors SF. The power(s) of DPCH₁ and DPCH₂ (if applicable) measured at the BS antenna connector during the active time slots shall be set to the value(s) given in table 8.10A.
- (4) Measure the BLER of the wanted signal at the BS receiver.

Table 8.10A: Parameters of DPCH₀ and the wanted signal for 1,28 Mcps TDD

Test Number	BLER objective	Number of DPCH ₀	Power of each DPCH ₀ measured at the BS antenna connector [dBm]	Parameters of the wanted signal		
				DPCH	SF	Power measured at the BS antenna connector [dBm]
1	10 ⁻²	4	-91.3	DPCH ₁	8	-91.3
2	10 ⁻¹	1	-94.4	DPCH ₁	2	-88.4
	10 ⁻²	1	-92.1	DPCH ₁	2	-86.1
3	10 ⁻¹	1	-93.8	DPCH ₁	2	-87.8
	10 ⁻²	1	-91.7	DPCH ₁	2	-85.7
4	10 ⁻¹	0	-	DPCH ₁	16	-95.7
				DPCH ₂	2	-86.7
	10 ⁻²	0	-	DPCH ₁	16	-93.4
				DPCH ₂	2	-84.4

8.3.2.4.2.3 7,68 Mcps TDD option

- (1) Adjust the power of the band-limited white noise source in such a way that its power spectral density measured at the BS antenna connector takes on the value I_{oc} as specified in table 8.8B.
- (2) For a given test defined by the information data rate and the BLER objective, set the power of each DPCH₀ measured at the BS antenna connector during the active time slots to the value specified in table 8.10B.
- (3) Set up a call between the BS tester generating the wanted signal and the BS. The characteristics of the call shall be configured according to the information data rate to be provided and the corresponding UL reference measurement channel defined in Annex A. Depending on the information data rate, the UL reference

measurement channel makes use of one or two Dedicated Physical Channels (DPCH₁ and DPCH₂) with different spreading factors SF. The power(s) of DPCH₁ and DPCH₂ (if applicable) measured at the BS antenna connector during the active time slots shall be set to the value(s) given in table 8.10B.

(4) Measure the BLER of the wanted signal at the BS receiver.

Table 8.10B: Parameters of DPCH₀ and the wanted signal

Test Number	BLER objective	Number of DPCH ₀	Power of each DPCH ₀ measured at the BS antenna connector [dBm]	Parameters of the wanted signal		
				DPCH	SF	Power measured at the BS antenna connector [dBm]
1	10 ⁻²	6	-97	DPCH ₁	16	-94

8.3.2.5 Test Requirements

NOTE: If the Test Requirements below differ from the Minimum Requirements, then the Test Tolerance applied for this test is non-zero. The Test Tolerance for this test is defined in subclause 5.11 and the explanation of how the Minimum Requirement has been relaxed by the Test Tolerance is given in Annex D.

8.3.2.5.1 3,84 Mcps TDD option

The BLER measured according to subclause 8.3.2.4.2 shall not exceed the limits specified in table 8.9.

8.3.2.5.2 1,28 Mcps TDD option

The BLER measured according to subclause 8.3.2.4.2 shall not exceed the limits specified in table 8.9A

8.3.2.5.3 7,68 Mcps TDD option

The BLER measured according to subclause 8.3.2.4.2 shall not exceed the limits specified in table 8.9B.

8.3.3 Multipath fading Case 3

8.3.3.1 Definition and applicability

The performance requirement of DCH in multipath fading Case 3 is determined by the maximum Block Error Ratio (BLER) allowed when the receiver input signal is at a specified \hat{I}_{or}/I_{oc} limit. The BLER is calculated for each of the measurement channels supported by the base station.

The requirements in this subclause shall apply to Wide Area BS only. There is no requirement to test Local Area BS and Home BS in multipath fading Case 3 conditions.

8.3.3.2 Minimum Requirements

8.3.3.2.1 3,84 Mcps TDD option

For the parameters specified in table 8.11, the BLER should not exceed the piece-wise linear BLER curve specified in Table 8.12. These requirements are applicable for TFCS size 16.

Table 8.11: Parameters in multipath Case 3 channel

Parameters	Unit	Test 1	Test 2	Test 3	Test 4
Number of DPCH _o		2	0	0	0
$\frac{DPCH_o - E_c}{I_{or}}$	dB	-6	-	-	-
I_{oc}	dBm/3,84 MHz	-89			
Cell Parameter*		0,1			
DPCH Channelization Codes*	C(k,Q)	C(1,8)	C(1,4) C(5,16)	C(1,2) C(9,16)	C(1,2)
DPCH _o Channelization Codes*	C(k,Q)	C(i,16) 3 ≤ i ≤ 4	-	-	-
Information Data Rate	Kbps	12,2	64	144	384

*Note: Refer to TS 25.223 for definition of channelization codes and cell parameter.

Table 8.12: Performance requirements in multipath Case 3 channel.

Test Number	$\frac{\hat{I}_{or}}{I_{oc}}$ [dB]	BLER
1	-0,1	10 ⁻²
2	0,8	10 ⁻¹
	2,7	10 ⁻²
	4,2	10 ⁻³
3	4,5	10 ⁻¹
	6,3	10 ⁻²
	8,0	10 ⁻³
4	3,6	10 ⁻¹
	5,0	10 ⁻²
	6,3	10 ⁻³

The normative reference for this requirement is TS 25.105 [1] subclause 8.3.3.1.1.

8.3.3.2.2 1,28 Mcps TDD option

For the parameters specified in table 8.11A, the BLER should not exceed the piece-wise linear BLER curve specified in Table 8.12A. These requirements are applicable for TFCS size 16.

Table 8.11A: Parameters in multipath Case 3 channel (1,28 Mcps option)

Parameters	Unit	Test 1	Test 2	Test 3	Test 4
Number of DPCH _o		4	1	1	0
Spread factor of DPCH _o		8	8	8	
$\frac{DPCH_o - E_c}{I_{or}}$	dB	-7	-7	-7	-
I_{oc}	dBm/1,28 MHz	-91			
Information Data Rate	kbps	12,2	64	144	384

Table 8.12A: Performance requirements multipath Case 3 channel (1,28 Mcps option).

Test Number	$\frac{\hat{I}_{or}}{I_{oc}}$ [dB]	BLER
1	5.6	10^{-2}
2	3.2	10^{-1}
	4.6	10^{-2}
	5.9	10^{-3}
3	3.7	10^{-1}
	4.8	10^{-2}
	5.9	10^{-3}
4	3.9	10^{-1}
	4.8	10^{-2}
	5.7	10^{-3}

The normative reference for this requirement is TS 25.105 [1] subclause 8.3.3.1.2

8.3.3.2.3 7,68 Mcps TDD option

For the parameters specified in table 8.11B, the BLER should not exceed the piece-wise linear BLER curve specified in Table 8.12B. These requirements are applicable for TFCS size 16.

Table 8.11B: Parameters in multipath Case 3 channel

Parameters	Unit	Test 1
Number of DPCH _o		6
$\frac{DPCH_o - E_c}{I_{or}}$	dB	-9
I_{oc}	dBm/7.68 MHz	-89
Cell Parameter*		0,1
DPCH Channelization Codes*	C(k,Q)	C(1, 16)
DPCH _o Channelization Codes*	C(k,Q)	C(i, 32) 3 ≤ i ≤ 8
Information Data Rate	kbps	12.2
*Note: Refer to TS 25.223 for definition of channelization codes and cell parameter.		

Table 8.12B: Performance requirements in multipath Case 3 channel.

Test Number	$\frac{\hat{I}_{or}}{I_{oc}}$ [dB]	BLER
1	-0.1	10^{-2}

The normative reference for this requirement is TS 25.105 [1] subclause 8.3.3.1.3.

8.3.3.3 Test purpose

The test purpose is to verify the ability of the BS to receive a prescribed test signal under defined propagation conditions (multipath fading Case 3) with a BLER not exceeding a specified limit. Within the wanted channel, independent intracell interference sources as well as an additional intercell interference source are taken into account. Therefore, this test - as all other tests in clause 8 - mainly checks the ability of the signal processing part of the receiver to extract the wanted signal from the distorted and interfered-with input signal, whereas the tests in clause 7 concentrate on the receiver RF part.

8.3.3.4 Method of test

8.3.3.4.1 Initial conditions

8.3.3.4.1.0 General test conditions

Test environment: normal; see subclause 5.9.1.

RF channels to be tested: B, M and T; see subclause 5.3.

8.3.3.4.1.1 3,84 Mcps TDD option

- (1) Connect the BS tester (UE simulator) generating the wanted signal and a set of interference generators to both BS antenna connectors for diversity reception via a combining network. The set of interference generators comprises a number of CDMA generators, each representing an individual intracell interferer (subsequently called DPCH₀ generators), and an additional band-limited white noise source, simulating interference from other cells. Each DPCH₀ generator shall produce an interfering signal that is equivalent to a valid UTRA TDD signal with spreading factor 16, using the same time slot(s) than the wanted signal and applying the same cell-specific scrambling code. The number of the DPCH₀ generators used in each test is given in table 8.11.
- (2) The wanted signal produced by the BS tester and the interfering signals produced by the DPCH₀ generators are individually passed through independent Multipath Fading Simulators (MFS) before entering the combining network. Each MFS shall be configured to simulate multipath fading Case 3.

8.3.3.4.1.2 1,28 Mcps TDD option

- (1) Connect the BS tester (UE simulator) generating the wanted signal and a set of interference generators to both BS antenna connectors for diversity reception via a combining network. The set of interference generators comprises a number of CDMA generators, each representing an individual intracell interferer (subsequently called DPCH₀ generators), and an additional band-limited white noise source, simulating interference from other cells. Each DPCH₀ generator shall produce an interfering signal that is equivalent to a valid UTRA TDD signal with spreading factor 8, using the same time slot(s) than the wanted signal and applying the same cell-specific scrambling code. The number of the DPCH₀ generators used in each test is given in table 8.11A.
- (2) The wanted signal produced by the BS tester and the interfering signals produced by the DPCH₀ generators are individually passed through independent Multipath Fading Simulators (MFS) before entering the combining network. Each MFS shall be configured to simulate multipath fading Case 3.

8.3.3.4.1.3 7,68 Mcps TDD option

- (1) Connect the BS tester (UE simulator) generating the wanted signal and a set of interference generators to both BS antenna connectors for diversity reception via a combining network. The set of interference generators comprises a number of CDMA generators, each representing an individual intracell interferer (subsequently called DPCH₀ generators), and an additional band-limited white noise source, simulating interference from other cells. Each DPCH₀ generator shall produce an interfering signal that is equivalent to a valid UTRA TDD signal with spreading factor 32, using the same time slot(s) than the wanted signal and applying the same cell-specific scrambling code. The number of the DPCH₀ generators used in each test is given in table 8.11B.
- (2) The wanted signal produced by the BS tester and the interfering signals produced by the DPCH₀ generators are individually passed through independent Multipath Fading Simulators (MFS) before entering the combining network. Each MFS shall be configured to simulate multipath fading Case 3.

8.3.3.4.2 Procedure

8.3.3.4.2.1 3,84 Mcps TDD option

- (1) Adjust the power of the band-limited white noise source in such a way that its power spectral density measured at the BS antenna connector takes on the value I_{oc} as specified in table 8.11.
- (2) For a given test defined by the information data rate and the BLER objective, set the power of each DPCH₀ measured at the BS antenna connector during the active time slots to the value specified in table 8.13.

- (3) Set up a call between the BS tester generating the wanted signal and the BS. The characteristics of the call shall be configured according to the information data rate to be provided and the corresponding UL reference measurement channel defined in Annex A. Depending on the information data rate, the UL reference measurement channel makes use of one or two Dedicated Physical Channels (DPCH₁ and DPCH₂) with different spreading factors SF. The power(s) of DPCH₁ and DPCH₂ (if applicable) measured at the BS antenna connector during the active time slots shall be set to the value(s) given in table 8.131.
- (4) Measure the BLER of the wanted signal at the BS receiver.

Table 8.13: Parameters of DPCH₀ and the wanted signal

Test Number	BLER objective	Number of DPCH ₀	Power of each DPCH ₀ measured at the BS antenna connector [dBm]	Parameters of the wanted signal		
				DPCH	SF	Power measured at the BS antenna connector [dBm]
1	10 ⁻²	2	-95,1	DPCH ₁	8	-92,1
2	10 ⁻¹	0	-	DPCH ₁	16	-95,2
				DPCH ₂	4	-89,2
	10 ⁻²	0	-	DPCH ₁	16	-93,3
				DPCH ₂	4	-87,3
	10 ⁻³	0	-	DPCH ₁	16	-91,8
				DPCH ₂	4	-85,8
3	10 ⁻¹	0	-	DPCH ₁	16	-94,0
				DPCH ₂	2	-85,0
	10 ⁻²	0	-	DPCH ₁	16	-92,2
	10 ⁻³	0	-	DPCH ₁	16	-90,5
				DPCH ₂	2	-81,5
4	10 ⁻¹	0	-	DPCH ₁	2	-85,4
	10 ⁻²	0	-	DPCH ₁	2	-84,0
	10 ⁻³	0	-	DPCH ₁	2	-82,7

8.3.3.4.2.2 1,28 Mcps TDD option

- (1) Adjust the power of the band-limited white noise source in such a way that its power spectral density measured at the BS antenna connector takes on the value I_{oc} as specified in table 8.11A.
- (2) For a given test defined by the information data rate and the BLER objective, set the power of each DPCH₀ measured at the BS antenna connector during the active time slots to the value specified in table 8.13A.
- (3) Set up a call between the BS tester generating the wanted signal and the BS. The characteristics of the call shall be configured according to the information data rate to be provided and the corresponding UL reference measurement channel defined in Annex A. Depending on the information data rate, the UL reference measurement channel makes use of one or two Dedicated Physical Channels (DPCH₁ and DPCH₂) with different spreading factors SF. The power(s) of DPCH₁ and DPCH₂ (if applicable) measured at the BS antenna connector during the active time slots shall be set to the value(s) given in table 8.13A.
- (4) Measure the BLER of the wanted signal at the BS receiver.

Table 8.13A: Parameters of DPCH₀ and the wanted signal for 1,28 Mcps TDD

Test Number	BLER objective	Number of DPCH ₀	Power of each DPCH ₀ measured at the BS antenna connector [dBm]	Parameters of the wanted signal		
				DPCH	SF	Power measured at the BS antenna connector [dBm]
1	10 ⁻²	4	-92.4	DPCH ₁	8	-92.4
2	10 ⁻¹	1	-94.8	DPCH ₁	2	-88.8
	10 ⁻²	1	-93.4	DPCH ₁	2	-87.4
	10 ⁻³	1	-92.1	DPCH ₁	2	-86.1
3	10 ⁻¹	1	-94.3	DPCH ₁	2	-88.3
	10 ⁻²	1	-93.2	DPCH ₁	2	-87.2
	10 ⁻³	1	-92.1	DPCH ₁	2	-86.1
4	10 ⁻¹	0	-	DPCH ₁	16	-96.6
				DPCH ₂	2	-87.6
	10 ⁻²	0	-	DPCH ₁	16	-95.7
				DPCH ₂	2	-86.7
	10 ⁻³	0	-	DPCH ₁	16	-94.8
DPCH ₂				2	-85.8	

8.3.3.4.2.3 7,68 Mcps TDD option

- (1) Adjust the power of the band-limited white noise source in such a way that its power spectral density measured at the BS antenna connector takes on the value I_{oc} as specified in table 8.11B.
- (2) For a given test defined by the information data rate and the BLER objective, set the power of each DPCH₀ measured at the BS antenna connector during the active time slots to the value specified in table 8.13B.
- (3) Set up a call between the BS tester generating the wanted signal and the BS. The characteristics of the call shall be configured according to the information data rate to be provided and the corresponding UL reference measurement channel defined in Annex A. Depending on the information data rate, the UL reference measurement channel makes use of one or two Dedicated Physical Channels (DPCH₁ and DPCH₂) with different spreading factors SF. The power(s) of DPCH₁ and DPCH₂ (if applicable) measured at the BS antenna connector during the active time slots shall be set to the value(s) given in table 8.13B.
- (4) Measure the BLER of the wanted signal at the BS receiver.

Table 8.13B: Parameters of DPCH₀ and the wanted signal

Test Number	BLER objective	Number of DPCH ₀	Power of each DPCH ₀ measured at the BS antenna connector [dBm]	Parameters of the wanted signal		
				DPCH	SF	Power measured at the BS antenna connector [dBm]
1	10 ⁻²	6	-98,1	DPCH ₁	16	-95,1

8.3.3.5 Test Requirements

NOTE: If the Test Requirements below differ from the Minimum Requirements, then the Test Tolerance applied for this test is non-zero. The Test Tolerance for this test is defined in subclause 5.11 and the explanation of how the Minimum Requirement has been relaxed by the Test Tolerance is given in Annex D.

8.3.3.5.1 3,84 Mcps TDD option

The BLER measured according to subclause 8.3.3.4.2 shall not exceed the limits specified in table 8.12.

8.3.3.5.2 1,28 Mcps TDD option

The BLER measured according to subclause 8.3.3.4.2 shall not exceed the limits specified in table 8.12A.

8.3.3.5.3 7,68 Mcps TDD option

The BLER measured according to subclause 8.3.3.4.2 shall not exceed the limits specified in table 8.12B.

8.3A Demodulation of DCH in high speed train conditions

8.3A.1 Definition and applicability

The performance requirement of DCH in high speed train conditions is determined by the maximum BLER allowed when the receiver input signal is at a specified \hat{I}_{or}/I_{oc} limit. The BLER is calculated for the measurement channel supported by the base station.

This requirement shall only be applied to BS supporting high speed mode.

8.3A.2 Minimum requirement

8.3A.2.1 3.84 Mcps TDD option

(void)

8.3A.2.2 1.28 Mcps TDD option

For the parameters specified in Table 8.13C the BLER should not exceed the BLER requirement specified in Table 8.13D. These requirements are applicable for TFCS size 16.

Table 8.13C: DCH parameters in high speed train condition

Parameters	Unit	Test 1	Test 2
Number of DPCHo		4	1
Spread factor of DPCHo		8	8
Scrambling code and basic midamble code number*		0	0
DPCH Channelization Codes*	C(k,Q)	C(1,8)	C(1,2)
DPCHo Channelization Codes*	C(k,Q)	C(i,8) 2 ≤ i ≤ 5	C(5,8)
$\frac{DPCH_o - E_c}{I_{or}}$	dB	-7	-7
loc	dBm/1.28MHz	-91	
Information Data Rate	Kbps	12.2	64

*Note: Refer to TS 25.223 for definition of channelization codes and cell parameter.

Table 8.13D: DCH requirements in high speed train condition

Test number	Scenario	dual receiver antenna diversity	$\frac{\hat{I}_{or}}{I_{oc}}$ [dB]	BLER
1	1	On	4.0	10^{-2}
		Off *	7.5	10^{-2}
	3	Off *	7.7	10^{-2}
2	1	On	1.2	10^{-1}
		On	2.0	10^{-2}
		Off *	4.6	10^{-1}
	3	Off *	5.4	10^{-2}
		Off *	4.8	10^{-1}
		Off *	6.0	10^{-2}

*Note: The requirement is only applicable for BS without receiver antenna diversity, the required $\frac{\hat{I}_{or}}{I_{oc}}$ shall be applied at the BS Rx antenna port.

The normative reference for this requirement is TS 25.105 [1] subclause 8.3A.2.2.

8.3A.2.3 7.68 Mcps TDD option

(void)

8.3A.3 Test purpose

The test shall verify the receiver's ability to receive the test signal in high speed train conditions with a BLER not exceeding the specified limit.

8.3A.4 Method of test

8.3A.4.1 Initial conditions

8.3A.4.1.1 General test conditions

Test environment: normal; see subclause 5.9.1

RF channels to be tested: B, M and T; see subclause 5.3

8.3A.4.1.1 3.84 Mcps TDD option

(void)

8.3A.4.1.1 1.28 Mcps TDD option

Connect the BS tester (UE simulator) generating the wanted signal, Channel Simulator generating Doppler shift and a set of interference generators to both BS antenna connectors for diversity reception via a combining network. The set of interference generators comprises a number of CDMA generators, each representing an individual intracell interferer (subsequently called DPCH₀ generators), and an additional band-limited white noise source, simulating interference from other cells. Each DPCH₀ generator shall produce an interfering signal that is equivalent to a valid UTRA TDD signal with spreading factor 8, using the same time slot(s) than the wanted signal and applying the same cell-specific scrambling code. The number of the DPCH₀ generators used in each test is given in table 8.13C.

8.3A.4.1.1 7.68 Mcps TDD option

(void)

8.3A.4.2 Procedure

8.3A.4.2.1 3.84 Mcps TDD option

(void)

8.3A.4.2.2 1.28 Mcps TDD option

- (1) Adjust the power of the band-limited white noise source in such a way that its power spectral density measured at the BS antenna connector takes on the value I_{oc} as specified in table 8.13C.
- (2) For a given test defined by the information data rate and the BLER objective, set the power of each DPCH₀ measured at the BS antenna connector during the active time slots to the value specified in table 8.13E.
- (4) The Channel Simulator shall be configured according to the corresponding Doppler shift trajectories defined in annex B.
- (5) Set up a call between the BS tester generating the wanted signal and the BS. The characteristics of the call shall be configured according to the information data rate to be provided and the corresponding UL reference measurement channel defined in Annex A. Depending on the information data rate, the UL reference measurement channel makes use of one or two Dedicated Physical Channels (DPCH₁ and DPCH₂) with different spreading factors SF. The power(s) of DPCH₁ and DPCH₂ (if applicable) measured at the BS antenna connector during the active time slots shall be set to the value(s) given in table 8.13E.
- (6) Measure the BLER of the wanted signal at the BS receiver.

Table 8.13E: Parameters of DPCH₀ and the wanted signal for 1,28 Mcps TDD

Test Number	Scenario	Dual receiver antenna diversity	BLER objective	Number of DPCH ₀	Power of each DPCH ₀ measured at the BS antenna connector [dBm]	Parameters of the wanted signal		
						DPCH	SF	Power measured at the BS antenna connector [dBm]
1	1	On	10 ⁻²	4	-94.0	DPCH ₁	8	-94.0
		Off *	10 ⁻²	4	-90.5	DPCH ₁	8	-90.5
	3	Off *	10 ⁻²	4	-90.3	DPCH ₁	8	-90.3
2	1	On	10 ⁻¹	1	-96.8	DPCH ₁	2	-90.8
		On	10 ⁻²	1	-96.0	DPCH ₁	2	-90.0
		Off *	10 ⁻¹	1	-93.4	DPCH ₁	2	-87.4
		Off *	10 ⁻²	1	-92.6	DPCH ₁	2	-86.6
	3	Off *	10 ⁻¹	1	-93.2	DPCH ₁	2	-87.2
		Off *	10 ⁻²	1	-92.0	DPCH ₁	2	-86.0
*Note: The requirement is only applicable for BS without receiver antenna diversity, the required $\frac{\hat{I}_{or}}{I_{oc}}$ shall be applied at the BS Rx antenna port.								

8.3A.4.2.3 7.68 Mcps TDD option

(void)

8.3A.5 Test requirements

NOTE: If the Test Requirement below differs from the Minimum Requirement, then the Test Tolerance applied for this test is non-zero. The Test Tolerance for this test is defined in subclause 5.11 and the explanation of how the Minimum Requirement has been relaxed by the Test Tolerance is given in Annex D.

8.3A.5.1 3,84 Mcps TDD option

(void)

8.3A.5.2 1,28 Mcps TDD option

The BLER measured according to subclause 8.3A.4.2.2. shall not exceed the limits specified in table 8.13F.

Table 8.13F: DCH requirements in high speed train condition

Test number	Scenario	dual receiver antenna diversity	$\frac{\hat{I}_{or}}{I_{oc}}$ [dB]	BLER
1	1	On	4.4	10^{-2}
		Off *	7.9	10^{-2}
	3	Off *	8.1	10^{-2}
2	1	On	1.6	10^{-1}
		On	2.4	10^{-2}
		Off *	5.0	10^{-1}
		Off *	5.8	10^{-2}
	3	Off *	5.2	10^{-1}
		Off *	6.4	10^{-2}
<p>*Note: The requirement is only applicable for BS without receiver antenna diversity, the required $\frac{\hat{I}_{or}}{I_{oc}}$ shall be applied at the BS Rx antenna port.</p>				

8.3A.5.3 7,68 Mcps TDD option

(void)

8.4 Demodulation of E-DCH FRC in multipath fading conditions

8.4.1 Definition and applicability

The performance requirement of the E-DCH in multi-path fading condition is determined by the minimum throughput R.

8.4.2 Minimum Requirements

8.4.2.1 3,84 Mcps TDD Option

For the test parameters specified in Table 8.14, the minimum requirements are specified in Table 8.15.

Table 8.14: Test parameters for testing E-DCH (3,84 Mcps TDD Option)

Parameter		Unit	Value		
			FRC1	FRC2	FRC3
Max information rate		kbps	34.7	1083.1	2073.7
I_{oc}	Wide Area BS	dBm/3,84 MHz	-89		
	Local Area BS	dBm/3,84 MHz	-74		
E-DCH E_c/I_{or}		dB	0	0	0
Cell Parameter*			0, 1		
E-DCH channelization code*		C(k, Q)	C(1, 16)	C(1, 2)	C(1, 1)
RSN			{0, 1, 2, 3}		
HARQ combining			IR		
Maximum number of HARQ transmission			4		
Power control			OFF		
Receiver antenna diversity			ON		
Midamble			Default midamble		
Physical channels to be turned on			E-PUCH		
Propagation condition			PA3, PB3, VA30, VA120		
*Note: Refer to TS 25.223 for definition of channelization codes and cell parameter.					

Table 8.15 Minimum Requirement for E-DCH (3,84 Mcps TDD Option)

Fixed Reference Channel		Reference value, \hat{I}_{or}/I_{oc} (dB), for $R \geq 30\%$ and $R \geq 70\%$ of maximum information bit rate		
Propagation conditions		FRC1	FRC2	FRC3
Pedestrian A (3 kmph)	30%	-13.76	-0.55	4.94
	70%	-9.89	5.2	12.76
Pedestrian B (3 kmph)	30%	-12.12	0.48	5.13
	70%	-9.46	5.22	13.1
Vehicular A (30 kmph)	30%	-12.58	-0.62	5.14
	70%	-9.51	5.3	13.46
Vehicular A (120 kmph)	30%	-12.55	-0.69	5.1
	70%	-9.78	5.22	13.14

8.4.2.2 1.28Mcps TDD option

For the test parameters specified in Table 8.14A, the minimum requirements are specified in Table 8.15A.

Table 8.14A: Test parameters for testing E-DCH (1.28 Mcps TDD Option)

Parameter		Unit	Value			
			FRC1	FRC2	FRC3	FRC4
Max information rate		kbps	56.4	227.8	515.6	1281.2
I_{oc}	Wide Area BS	dBm/1.28 MHz	-91			
	Local Area BS	dBm/1.28MHz	-77			
	Home BS	dBm/1.28MHz	-82			
Scrambling code and basic midamble code number*			0	0	0	0
E-PUCH channelization code*		C(k, Q)	C(1, 4)	C(1, 2)	C(1,2)	C(1,1)
RSN			{0, 1, 2, 3}			
HARQ combining			IR			
Maximum number of HARQ transmission			4			
Power control			OFF			
Receiver antenna diversity			ON			
Midamble			Default midamble			
Propagation condition			PA3, PB3, VA30			
*Note: Refer to TS 25.223 for definition of channelization codes, scrambling code and basic midamble code						

Table 8.15A Minimum Requirement for E-DCH (1.28 Mcps TDD Option)

Fixed Reference Channel		Reference value, \hat{I}_{or}/I_{oc} (dB), for $R \geq 30\%$ and $R \geq 70\%$ of maximum information bit rate			
Propagation conditions		FRC1	FRC2	FRC3	FRC4
Pedestrian A (3 kmph)	30%	-6.78	-1.58	2.84	6.34
	70%	-1.83	4.6	10.19	13.45
Pedestrian B (3 kmph)	30%	-5.62	-1.1	2.88	6.55
	70%	-1.65	5.09	8.99	12.26
Vehicular A (30 kmph)	30%	-4.96	-0.88	3.09	7.14
	70%	-1.2	6.0	10.89	14.01

8.4.2.3 7.68 Mcps TDD Option

For the test parameters specified in Table 8.14B, the minimum requirements are specified in Table 8.15B.

Table 8.14B: Test parameters for testing E-DCH (7.68 Mcps TDD Option)

Parameter		Unit	Value		
			FRC1	FRC2	FRC3
Max information rate		kbps	35.9	1083.1	2085.1
I_{oc}	Wide Area BS	dBm/7.68 MHz	-89		
	Local Area BS	dBm/7.68 MHz	-74		
E-DCH E_c/I_{or}		dB	0	0	0
Cell Parameter*			0, 1		
E-DCH channelization code*		C(k, Q)	C(1, 32)	C(1, 4)	C(1, 2)
RSN			{0, 1, 2, 3}		
HARQ combining			IR		
Maximum number of HARQ transmission			4		
Power control			OFF		
Receiver antenna diversity			ON		
Midamble			Default midamble		
Physical channels to be turned on			E-PUCH		
Propagation condition			PA3, PB3, VA30, VA120		

*Note: Refer to TS 25.223 for definition of channelization codes and cell parameter.

Table 8.15B Minimum Requirement for E-DCH (7.68 Mcps TDD Option)

Fixed Reference Channel		Reference value, I_{or}/I_{oc} (dB), for $R \geq 30\%$ and $R \geq 70\%$ of maximum information bit rate		
		FRC1	FRC2	FRC3
Propagation conditions				
Pedestrian A (3 kmph)	30%	-16.22	-3.71	1.72
	70%	-12.56	1.79	9.39
Pedestrian B (3 kmph)	30%	-14.44	-3.71	1.45
	70%	-11.54	1.48	8.87
Vehicular A (30 kmph)	30%	-14.81	-3.68	1.48
	70%	-11.84	1.89	9.28
Vehicular A (120 kmph)	30%	-14.81	-3.83	1.38
	70%	-12.27	1.67	9.17

8.4.3 Test purpose

The test shall verify the receiver's ability to receive the test signal under multipath fading propagation conditions with a throughput not below a specified limit.

8.4.4 Method of test

8.4.4.1 Initial conditions

8.4.4.1.0 General test conditions

Test environment: normal; see subclause 5.9.1.

RF channels to be tested: B, M and T; see subclause 5.3.

8.4.4.1.1 3,84 Mcps TDD option

- (1) Connect the BS tester (UE simulator) generating the wanted signal and a band-limited white noise source, simulating interference from other cells, to both BS antenna connectors for diversity reception via a combining network.
- (2) The wanted signal produced by the BS tester to both BS antenna connectors are individually passed through independent Multipath Fading Simulators (MFS) before entering the combining network. Each MFS shall be configured to simulate multipath fading conditions specified in Table 8.14 and 8.15.

8.4.4.1.2 1.28Mcps TDD option

- (1) Connect the BS tester (UE simulator) generating the wanted signal and a band-limited white noise source, simulating interference from other cells, to both BS antenna connectors for diversity reception via a combining network.
- (2) The wanted signal produced by the BS tester to both BS antenna connectors are individually passed through independent Multipath Fading Simulators (MFS) before entering the combining network. Each MFS shall be configured to simulate multipath fading conditions specified in Table 8.14A and 8.15A.

8.4.4.1.3 7.68 Mcps TDD option

- (1) Connect the BS tester (UE simulator) generating the wanted signal and a band-limited white noise source, simulating interference from other cells, to both BS antenna connectors for diversity reception via a combining network.
- (2) The wanted signal produced by the BS tester to both BS antenna connectors are individually passed through independent Multipath Fading Simulators (MFS) before entering the combining network. Each MFS shall be configured to simulate multipath fading conditions specified in Table 8.14B and 8.15B.

8.4.4.2 Procedure

8.4.4.2.1 3,84 Mcps TDD option

- (1) Adjust the power of the band-limited white noise source in such a way that its power spectral density measured at the BS antenna connector takes on the value I_{oc} as specified in table 8.14.
- (2) The characteristics of the wanted signal shall be configured according to the corresponding E-DCH Fixed Reference Channel (FRC) measurement channel defined in annex A.3. Depending upon the E-DCH FRC measurement channel makes use of one physical channel (E-PUCH) with different spreading factors SF. The power of the E-PUCH measured at the BS antenna connector during the active time slots shall be set to the values given in Table 8.16.
- (3) The Multipath Fading Simulators shall be configured according to the corresponding channel model defined in annex D.
- (4) For each of the fixed reference channels in table 8.16 applicable for the base station, measure the throughput for each E-PUCH power and propagation condition settings.

Table 8.16: Parameters of the wanted signal (E-PUCH) (3,84 Mcps TDD Option)

Propagation Conditions	Throughput R (% of max information bit rate)	Wanted signal (E-PUCH) power measured at the BS antenna connector (dBm)					
		Wide Area BS			Local Area BS		
		FRC1	FRC2	FRC3	FRC1	FRC2	FRC3
Pedestrian A (3 kmph)	30%	-102.76	-89.55	-84.06	-87.76	-74.55	-69.06
	70%	-98.89	-83.80	-76.24	-83.89	-68.80	-61.24
Pedestrian B (3 kmph)	30%	-101.12	-88.52	-83.87	-86.12	-73.52	-68.87
	70%	-98.46	-83.78	-75.90	-83.46	-68.78	-60.90
Vehicular A (30 kmph)	30%	-101.58	-89.62	-83.86	-86.58	-74.62	-68.86
	70%	-98.51	-83.70	-75.54	-83.51	-68.70	-60.54
Vehicular A (120 kmph)	30%	-101.55	-89.69	-83.90	-86.55	-74.69	-68.90
	70%	-98.78	-83.78	-75.86	-83.78	-68.78	-60.86

8.4.4.2.2 1.28Mcps TDD option

- (1) Adjust the power of the band-limited white noise source in such a way that its power spectral density measured at the BS antenna connector takes on the value I_{oc} as specified in table 8.14A.
- (2) The characteristics of the wanted signal shall be configured according to the corresponding E-DCH Fixed Reference Channel (FRC) measurement channel defined in annex A.3. Depending upon the E-DCH FRC measurement channel makes use of one physical channel (E-PUCH) with different spreading factors SF. The power of the E-PUCH measured at the BS antenna connector during the active time slots shall be set to the values given in Table 8.16A.
- (3) The Multipath Fading Simulators shall be configured according to the corresponding channel model defined in annex B.
- (4) For each of the fixed reference channels in table 8.16A applicable for the base station, measure the throughput for each E-PUCH power and propagation condition settings.

Table 8.16A: Parameters of the wanted signal (E-PUCH) (1.28 Mcps TDD Option)

Propagation Conditions	Throughput R (% of max information bit rate)	Wanted signal (E-PUCH) power measured at the BS antenna connector (dBm)											
		Wide Area BS				Local Area BS				Wide Area BS			
		FRC1	FRC2	FRC1	FRC2	FRC1	FRC2	FRC1	FRC2	FRC1	FRC2	FRC3	FRC4
Pedestrian A (3 kmph)	30%	-97.78	-92.58	-97.78	-92.58	-97.78	-92.58	-97.78	-92.58	-88.78	-83.58	-79.16	-75.66
	70%	-92.83	-86.4	-92.83	-86.4	-92.83	-86.4	-92.83	-86.4	-83.83	-77.4	-71.81	-68.55
Pedestrian B (3 kmph)	30%	-96.62	-92.1	-96.62	-92.1	-96.62	-92.1	-96.62	-92.1	-87.62	-83.1	-79.12	-75.45
	70%	-92.65	-85.91	-92.65	-85.91	-92.65	-85.91	-92.65	-85.91	-83.65	-76.91	-73.01	-69.74
Vehicular A (30 kmph)	30%	-95.96	-91.88	-95.96	-91.88	-95.96	-91.88	-95.96	-91.88	-86.96	-82.88	-78.91	-74.86
	70%	-92.2	-85	-92.2	-85	-92.2	-85	-92.2	-85	-83.2	-76	-71.11	-67.99

8.4.4.2.3 7.68 Mcps TDD option

- (1) Adjust the power of the band-limited white noise source in such a way that its power spectral density measured at the BS antenna connector takes on the value I_{oc} as specified in table 8.14B.
- (2) The characteristics of the wanted signal shall be configured according to the corresponding E-DCH Fixed Reference Channel (FRC) measurement channel defined in annex A.3. Depending upon the E-DCH FRC measurement channel makes use of one physical channel (E-PUCH) with different spreading factors SF. The power of the E-PUCH measured at the BS antenna connector during the active time slots shall be set to the values given in Table 8.16B.
- (3) The Multipath Fading Simulators shall be configured according to the corresponding channel model defined in annex D.

- (4) For each of the fixed reference channels in table 8.16B applicable for the base station, measure the throughput for each E-PUCH power and propagation condition settings.

Table 8.16B: Parameters of the wanted signal (E-PUCH) (7.68 Mcps TDD Option)

Propagation Conditions	Throughput R (% of max information bit rate)	Wanted signal (E-PUCH) power measured at the BS antenna connector (dBm)					
		Wide Area BS			Local Area BS		
		FRC1	FRC2	FRC3	FRC1	FRC2	FRC3
Pedestrian A (3 kmph)	30%	-105.22	-92.71	-87.28	-90.22	-77.71	-72.28
	70%	-101.56	-87.21	-79.61	-86.56	-72.21	-64.61
Pedestrian B (3 kmph)	30%	-103.44	-92.71	-87.55	-88.44	-77.71	-72.55
	70%	-100.54	-87.52	-80.13	-85.54	-72.52	-65.13
Vehicular A (30 kmph)	30%	-103.81	-92.68	-87.52	-88.81	-77.68	-72.52
	70%	-100.84	-87.11	-79.72	-85.84	-72.11	-64.72
Vehicular A (120 kmph)	30%	-103.81	-92.83	-87.62	-88.81	-77.83	-72.62
	70%	-101.27	-87.33	-79.83	-86.27	-72.33	-64.83

8.4.5 Test Requirements

NOTE: If the Test Requirements below differ from the Minimum Requirements, then the Test Tolerance applied for this test is non-zero. The Test Tolerance for this test is defined in subclause 5.11 and the explanation of how the Minimum Requirement has been relaxed by the Test Tolerance is given in Annex D.

8.4.5.1 3.84 Mcps TDD option

The throughput measured according to subclause 8.4.4.2 shall be at least the limits specified in table 8.15.

8.4.5.2 1.28 Mcps TDD option

The throughput measured according to subclause 8.4.4.2 shall be at least the limits specified in table 8.15A.

8.4.5.3 7.68 Mcps TDD option

The throughput measured according to subclause 8.4.4.2 shall be at least the limits specified in table 8.15B.

8.5 Performance of ACK error detection for HS-SICH

8.5.1 ACK error detection in static propagation conditions

8.5.1.1 3.84 Mcps TDD option

(void)

8.5.1.2 1.28 Mcps TDD option

8.5.1.2.1 Definition and applicability

The performance requirement of the HS-SICH is ACK error detection, P(ACK->NACK) when ACK is transmitted.

8.5.1.2.2 Minimum requirement

The performance requirement of ACK error detection, P(ACK->NACK) should not exceed the required error ratio for

the $\frac{\hat{I}_{or}}{I_{oc}}$ specified in Table 8.18A.

Table 8.17A: Test parameters for testing ACK error detection using HS-SICH type1 (1.28Mcps TDD Option)

Parameters		Unit	Test
Number of DPCH _o			2
Spread factor of DPCH _o			8
Scrambling code and basic midamble code number*			0
DPCH _o Channelization Codes*		C(k,Q)	C(i,8) 2 ≤ i ≤ 3
$\frac{DPCH_{o} - E_c}{I_{or}}$		dB	-4
$\frac{HS - SICH_{o} - E_c}{I_{or}}$		dB	-7
loc	Wide Area BS	dBm/1,28 MHz	-91
	Home BS	dBm/1,28 MHz	-82
Closed loop power control			Off
Midamble			Default midamble
*Note: Refer to TS 25.223 for definition of channelization codes and cell parameter.			

Table 8.17B: Test parameters for testing ACK error detection using HS-SICH type2 (1.28Mcps TDD Option)

Parameters		Unit	Test
Number of DPCH _o			2
Spread factor of DPCH _o			8
Scrambling code and basic midamble code number (note)			0
DPCH _o Channelization Codes*		C(k,Q)	C(i,8) 2 ≤ i ≤ 3
$\frac{DPCH_{o} - E_c}{I_{or}}$		dB	-4.8
$\frac{HS - SICH_{o} - E_c}{I_{or}}$		dB	-4.8
loc	Wide Area BS	dBm/1.28 MHz	-91
	Home BS	dBm/1.28 MHz	-82
Closed loop power control			Off
Midamble			Default midamble
NOTE: Refer to TS 25.223 for definition of channelization codes and cell parameter.			

Table 8.18A: Performance requirements for ACK error detection in AWGN channel using HS-SICH type1

Received $\frac{\hat{I}_{or}}{I_{oc}}$	Required error ratio
-3,1 dB	$< 10^{-2}$

Table 8.18B: Performance requirements for ACK error detection in AWGN channel using HS-SICH type2

Received $\frac{\hat{I}_{or}}{I_{oc}}$	Required error ratio
-5.3 dB	$< 10^{-2}$

The reference for this requirement is TS 25.105 subclause 8.5.

8.5.1.2.3 Test purpose

The test shall verify the receiver's ability to receive the test signal under static propagation conditions with an error ratio not exceeding a specified limit.

8.5.1.2.4 Method of test

8.5.1.2.4.1 Initial conditions

Test environment: normal; see subclause 5.9.1.

RF channels to be tested: B, M and T; see subclause 5.3

- (1) Connect the BS tester generating the wanted signal and AWGN generators to both BS antenna connectors for diversity reception via a combining network as shown in annex B. Connect the BS tester (UE simulator) generating the wanted signal and a set of interference generators to both BS antenna connectors for diversity reception via a combining network. The set of interference generators comprises a number of CDMA generators, each representing an individual intracell interferer (subsequently called DPCH0 generators), and an additional band-limited white noise source, simulating interference from other cells. Each DPCH0 generator shall produce an interfering signal that is equivalent to a valid UTRA TDD signal with spreading factor 8, using the same time slot(s) than the wanted signal and applying the same cell-specific scrambling code. The number of the DPCH0 generators used in each test is given in table 8.17A.

8.5.1.2.4.2 Procedure

- (1) Adjust the power of the band-limited white noise source in such a way that its power spectral density measured at the BS antenna connector takes on the value I_{oc} as specified in table 8.17A.
- (2) The characteristics of the wanted signal (HS-SICH) shall be configured according to the corresponding UL reference measurement channel defined in annex A. Set the power of HS-SICH and each DPCH0 measured at the BS antenna connector during the active time slots to the value specified in table 8.17A.
- (3) The test signal generator sends the ACKs with HS-SICH and DPCH0s. Adjust the equipment so that required $\frac{\hat{I}_{or}}{I_{oc}}$ specified in table 8.18A is achieved. The receiver tries to detect ACK. The error ratio is calculated for the ACKs that have been detected.

8.5.1.2.5 Test requirements

The performance of ACK error detection, $P(\text{ACK} \rightarrow \text{NACK})$ should not exceed the required error ratio for the

$\frac{\hat{I}_{or}}{I_{oc}}$ specified in Table 8.19A.

Table 8.19A: Performance requirements for ACK error detection in AWGN channel using HS-SICH type1

Received $\frac{\hat{I}_{or}}{I_{oc}}$	Required error ratio
-2,7dB	$< 10^{-2}$

Table 8.19B: Performance requirements for ACK error detection in AWGN channel using HS-SICH type2

Received $\frac{\hat{I}_{or}}{I_{oc}}$	Required error ratio
-4.9dB	$< 10^{-2}$

NOTE: If the Test Requirements below differ from the Minimum Requirements, then the Test Tolerance applied for this test is non-zero. The Test Tolerance for this test is defined in subclause 5.11 and the explanation of how the Minimum Requirement has been relaxed by the Test Tolerance is given in Annex D.

8.5.2 ACK error detection in multipath fading conditions

8.5.2.1 3,84Mcps TDD option

(void)

8.5.2.2 1,28Mcps TDD option

8.5.2.2.1 Definition and applicability

The performance requirement of the HS-SICH is ACK error detection, P(ACK->NACK) when ACK is transmitted..

8.5.2.2.2 Minimum requirement

The performance of ACK error detection, P(ACK->NACK) should not exceed the required error ratio for the $\frac{\hat{I}_{or}}{I_{oc}}$ specified in Table 8.20A.

Table 8.20A: Test parameters for testing ACK error detection using HS-SICH type1 (1,28Mcps TDD Option)

Parameters		Unit	Test
Number of DPCH _o			2
Spread factor of DPCH _o			8
Scrambling code and basic midamble code number*			0
DPCH _o Channelization Codes*		C(k,Q)	C(i,8) 2 ≤ i ≤ 3
$\frac{DPCH_{o} - E_c}{I_{or}}$		dB	-4
$\frac{HS - SICH_{o} - E_c}{I_{or}}$		dB	-7
I _{oc}	Wide Area BS	dBm/1,28 MHz	-91
	Home BS	dBm/1,28 MHz	-82
Closed loop power control			Off
Midamble			Default midamble
*Note: Refer to TS 25.223 for definition of channelization codes and cell parameter.			

Table 8.20B: Test parameters for testing ACK error detection using HS-SICH type2 (1.28Mcps TDD Option)

Parameters		Unit	Test
Number of DPCH _o			2
Spread factor of DPCH _o			8
Scrambling code and basic midamble code number (note)			0
DPCH _o Channelization Codes*		C(k,Q)	C(i,8) 2 ≤ i ≤ 3
$\frac{DPCH_{o} - E_c}{I_{or}}$		dB	-4.8
$\frac{HS - SICH_{o} - E_c}{I_{or}}$		dB	-4.8
I _{oc}	Wide Area BS	dBm/1.28 MHz	-91
	Home BS	dBm/1,28 MHz	-82
Closed loop power control			Off
Midamble			Default midamble
NOTE: Refer to TS 25.223 for definition of channelization codes and cell parameter.			

Table 8.21A: Performance requirements for ACK error detection in fading channels using HS-SICH type1

Propagation conditions	Received $\frac{\hat{I}_{or}}{I_{oc}}$ (dB)	Required error ratio
Case 1	1,2	< 10 ⁻²
Case 2*	0,9	< 10 ⁻²
Case 3*	0,2	< 10 ⁻²
*Note: This case is not applicable to Home BS		

Table 8.21B: Performance requirements for ACK error detection in fading channels using HS-SICH type2

Propagation conditions	Received $\frac{\hat{I}_{or}}{I_{oc}}$ (dB)	Required error ratio
Case 1	-1,2	$< 10^{-2}$
Case 2*	-0,7	$< 10^{-2}$
*Note: This case is not applicable to Home BS		

The reference for this requirement is TS 25.105 subclause 8.5.

8.5.2.2.3 Test purpose

The test shall verify the receiver's ability to receive the test signal under multipath fading propagation conditions with an error ratio not exceeding a specified limit.

8.5.2.2.4 Method of test

8.5.2.2.4.1 Initial conditions

Test environment: normal; see subclause 5.9.1.

RF channels to be tested: B, M and T; see subclause 5.3

- (1) Connect the BS tester generating the wanted signal and AWGN generators to both BS antenna connectors for diversity reception via a combining network as shown in annex B. Connect the BS tester (UE simulator) generating the wanted signal and a set of interference generators to both BS antenna connectors for diversity reception via a combining network. The set of interference generators comprises a number of CDMA generators, each representing an individual intracell interferer (subsequently called DPCH0 generators), and an additional band-limited white noise source, simulating interference from other cells. Each DPCH0 generator shall produce an interfering signal that is equivalent to a valid UTRA TDD signal with spreading factor 8, using the same time slot(s) than the wanted signal and applying the same cell-specific scrambling code. The number of the DPCH0 generators used in each test is given in table 8.20A.
- (2) The wanted signal produced by the BS tester and the interfering signals produced by the DPCH0 generators are individually passed through independent Multipath Fading Simulators (MFS) before entering the combining network. Each MFS shall be configured to simulate multipath fading Case 3.

8.5.2.2.4.2 Procedure

- (1) Adjust the power of the band-limited white noise source in such a way that its power spectral density measured at the BS antenna connector takes on the value I_{oc} as specified in table 8.20A.
- (2) The characteristics of the wanted signal (HS-SICH) shall be configured according to the corresponding UL reference measurement channel defined in annex A. Set the power of HS-SICH and each DPCH0 measured at the BS antenna connector during the active time slots to the value specified in table 8.20A.
- (3) The test signal generator sends the ACKs with HS-SICH and DPCH0s. Adjust the equipment so that required $\frac{\hat{I}_{or}}{I_{oc}}$ specified in table 8.21A is achieved. The receiver tries to detect ACK. The error ratio is calculated for the ACKs that have been detected.

8.5.2.2.5 Test requirements

The performance of ACK error detection, $P(\text{ACK} \rightarrow \text{NACK})$ should not exceed the required error ratio for the

$\frac{\hat{I}_{or}}{I_{oc}}$ specified in Table 8.22A.

Table 8.22A: Performance requirements for ACK error detection in fading channels using HS-SICH type1

Propagation conditions	Received $\frac{\hat{I}_{or}}{I_{oc}}$ (dB)	Required error ratio
Case 1	1,8	$< 10^{-2}$
Case 2*	1,5	$< 10^{-2}$
Case 3*	0,8	$< 10^{-2}$
*Note: This case is not applicable to Home BS		

Table 8.22B: Performance requirements for ACK error detection in fading channels using HS-SICH type2

Propagation conditions	Received $\frac{\hat{I}_{or}}{I_{oc}}$ (dB)	Required error ratio
Case 1	-0.6	$< 10^{-2}$
Case 2*	-0.1	$< 10^{-2}$
*Note: This case is not applicable to Home BS		

NOTE: If the Test Requirements below differ from the Minimum Requirements, then the Test Tolerance applied for this test is non-zero. The Test Tolerance for this test is defined in subclause 5.11 and the explanation of how the Minimum Requirement has been relaxed by the Test Tolerance is given in Annex D.

Annex A (normative): Measurement Channels

A.1 (void)

A.2 Reference measurement channel

A.2.1 UL reference measurement channel (12,2 kbps)

A.2.1.1 3,84 Mcps TDD option

Table A.1

Parameter	Value
Information data rate	12.2 kbps
RU's allocated	2 RU
Midamble	512 chips
Interleaving	20 ms
Power control	2 Bit/user
TFCI	16 Bit/user
Inband signalling DCCH	2 kbps
Puncturing level at Code rate 1/3 : DCH of the DTCH / DCH of the DCCH	10% / 0%

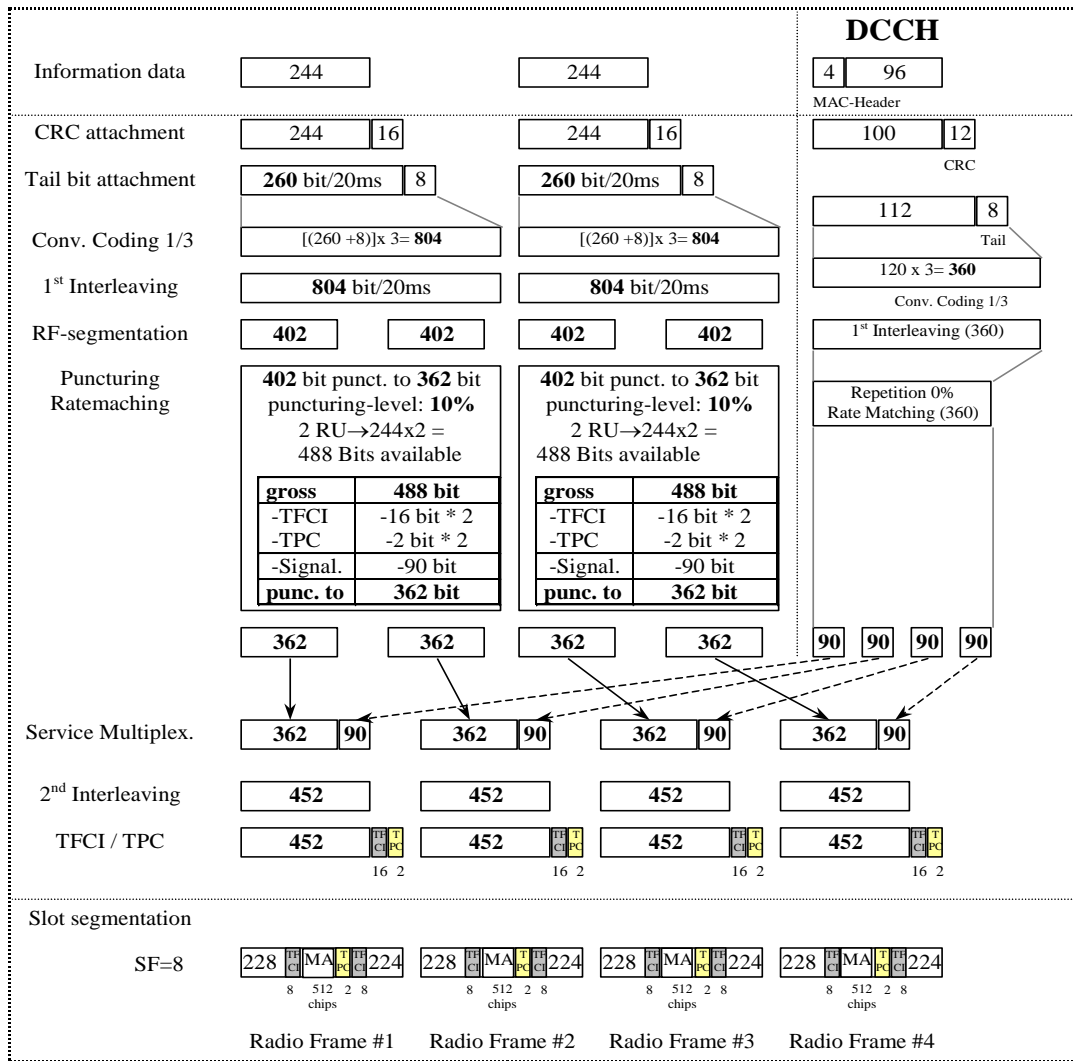

Figure A.1

A.2.1.2 1,28 Mcps option

Table A.1A

Parameter	Value
Information data rate	12.2 kbps
RU's allocated	1TS (1*SF8) = 2RU/5ms
Midamble	144
Interleaving	20 ms
Power control	4 Bit/user/10ms
TFCI	16 Bit/user/10ms
Synchronisation Shift (SS)	4 Bit/user/10ms
Inband signalling DCCH	2.4 kbps
Puncturing level at Code rate 1/3 : DCH of the DTCH/ DCH of the DCCH	33% / 33%

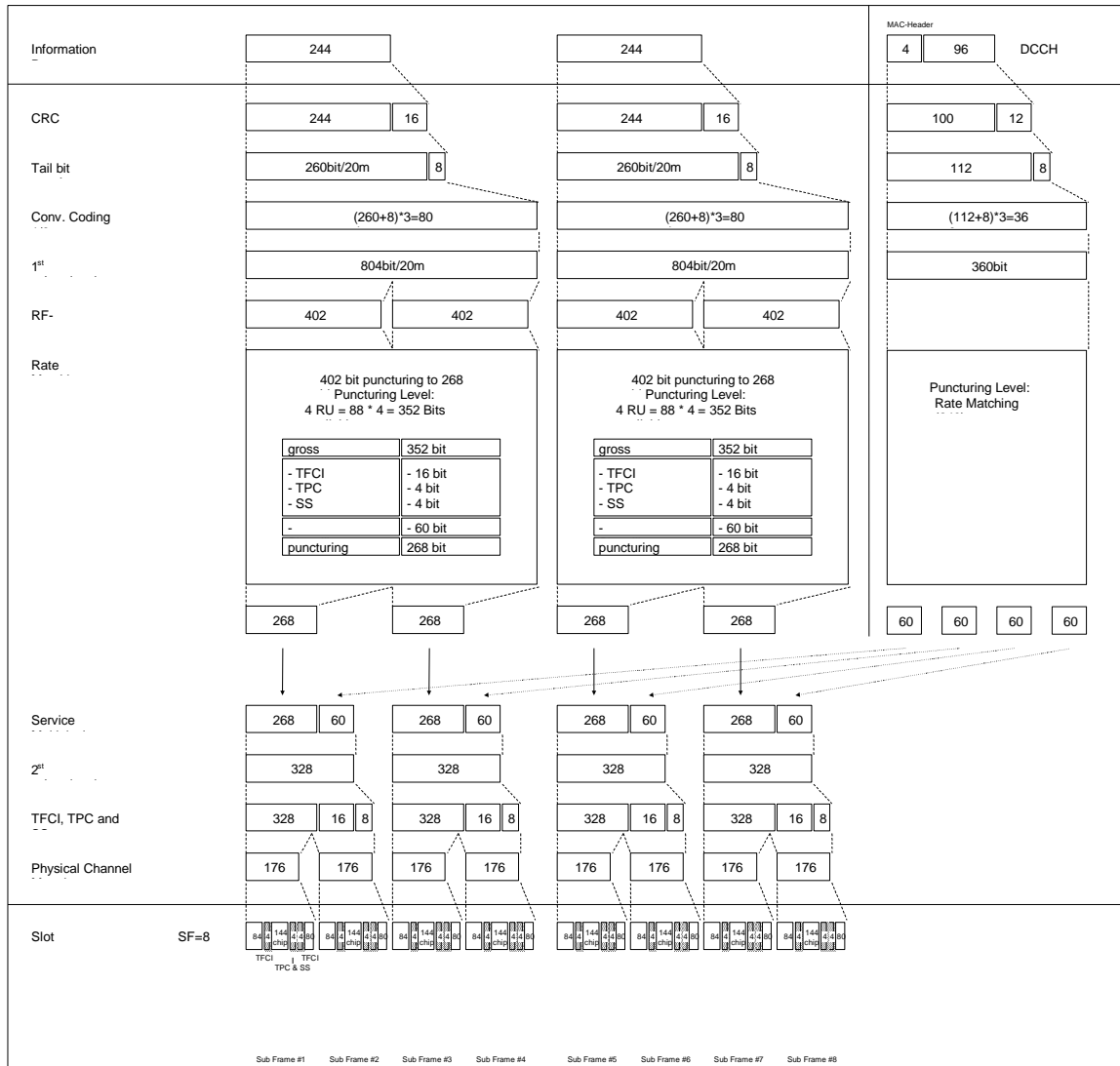

Figure A.1A

A.2.1.3 7,68 Mcps TDD Option

Table A.1B

Parameter	Value
Information data rate	12.2 kbps
RU's allocated	2 RU
Midamble	1024 chips
Interleaving	20 ms
Power control	2 Bit/user
TFCI	16 Bit/user
Inband signalling DCCH	2 kbps
Puncturing level at Code rate 1/3 : DCH of the DTCH / DCH of the DCCH	10% / 0%

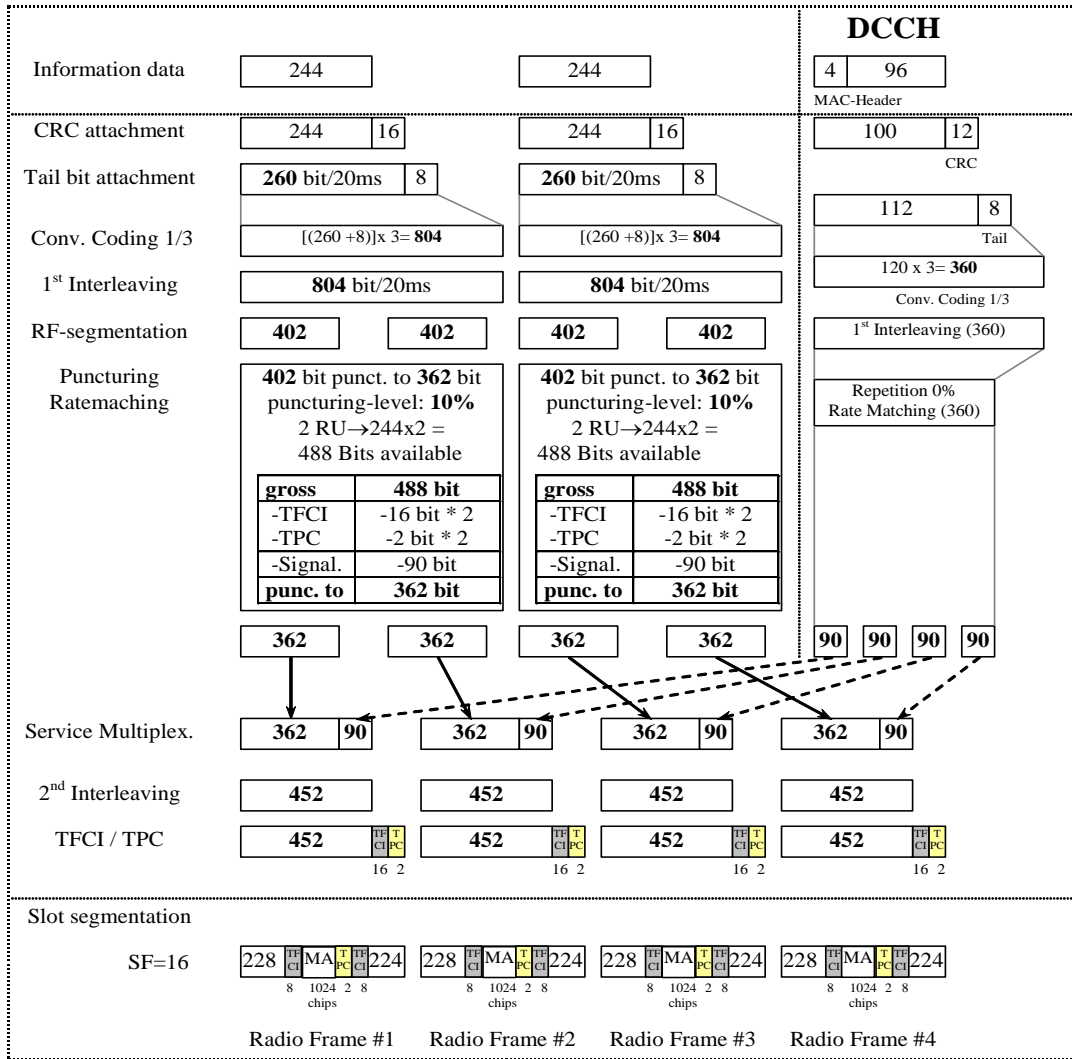

Figure A.1B

A.2.2 UL reference measurement channel (64 kbps)

A.2.2.1 3,84 Mcps TDD option

Table A.2

Parameter	Value
Information data rate	64 kbps
RU's allocated	1 SF4 + 1 SF16 = 5RU
Midamble	512 chips
Interleaving	20 ms
Power control	2 Bit/user
TFCI	16 Bit/user
Inband signalling DCCH	2 kbps
Puncturing level at Code rate : 1/3 DCH of the DTCH / 1/2 DCH of the DCCH	43.8% / 13.3%

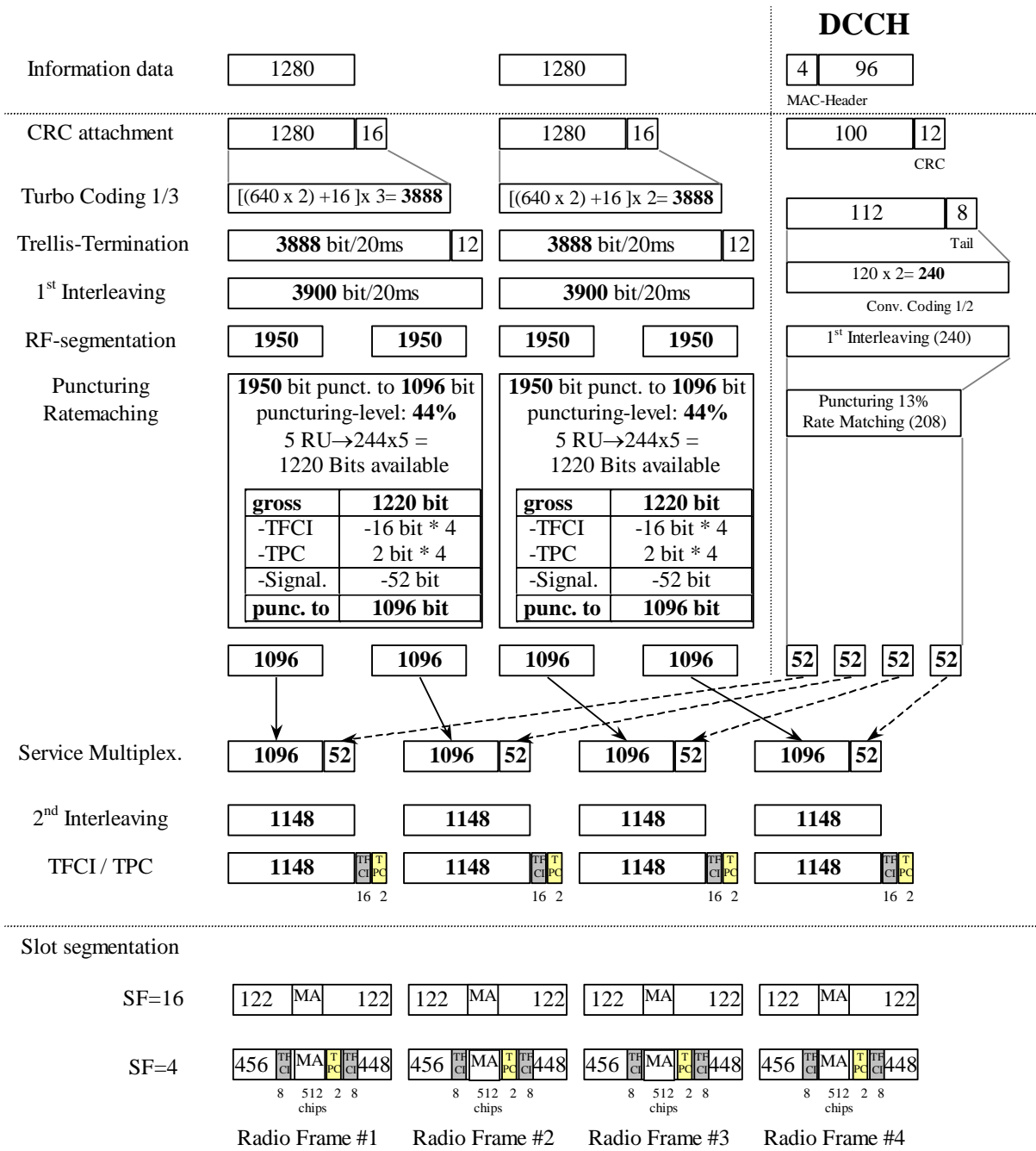

Figure A.2

A.2.2.2 1,28 Mcps TDD option

Table A.2A

Parameter	Value
Information data rate	64 kbps
RU's allocated	1TS (1*SF2) = 8RU/5ms
Midamble	144
Interleaving	20 ms
Power control (TPC)	4 Bit/user/10ms
TFCI	16 Bit/user/10ms
Synchronisation Shift (SS)	4 Bit/user/10ms
Inband signalling DCCH	2.4 kbps
Puncturing level at Code rate: 1/3 DCH of the DTCH / 1/2 DCH of the DCCH	32% / 0

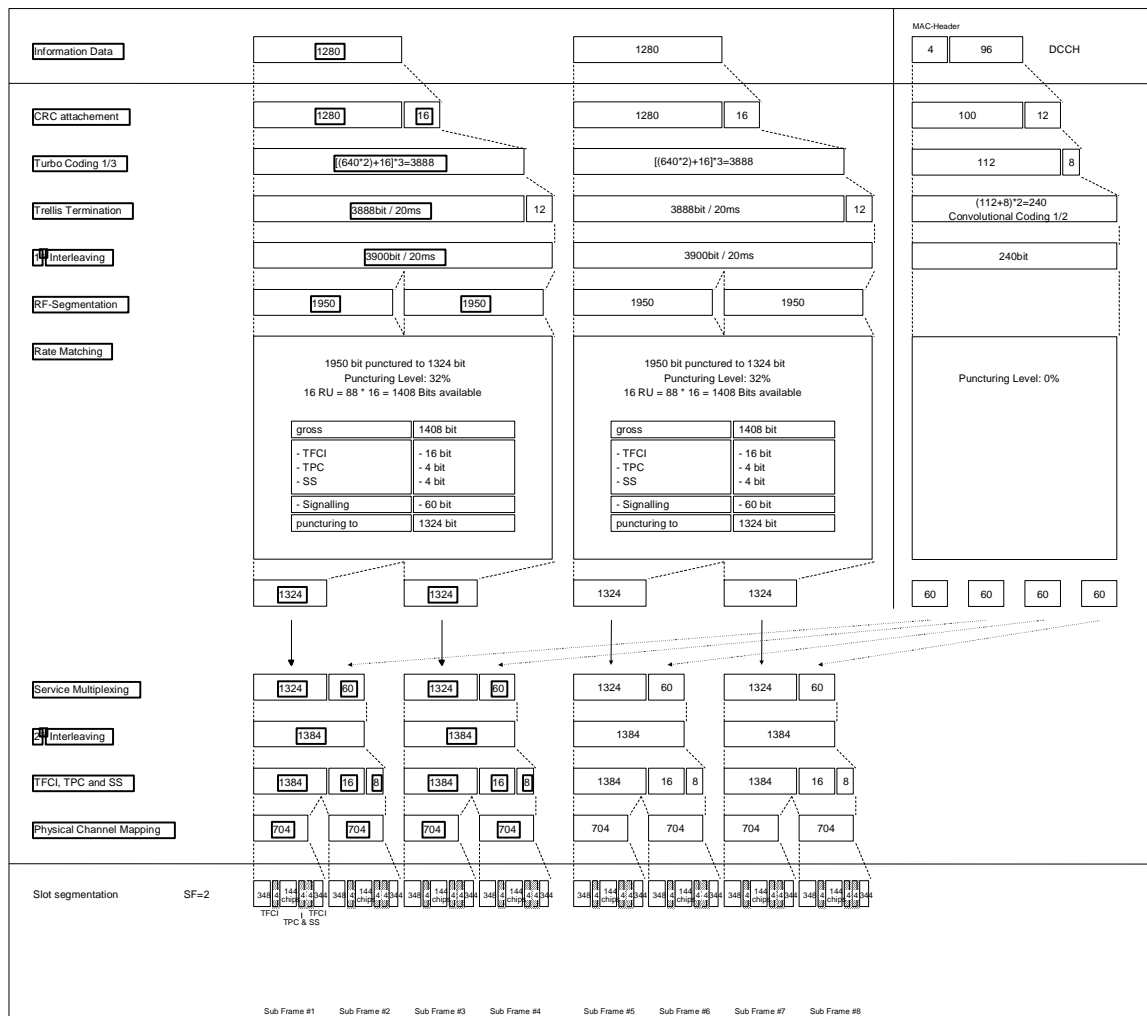

Figure A.2A

A.2.2.3 7,68 Mcps TDD Option

Table A.2B

Parameter	Value
Information data rate	64 kbps
RU's allocated	1 SF8 + 1 SF32 = 5RU
Midamble	1024 chips
Interleaving	20 ms
Power control	2 Bit/user
TFCI	16 Bit/user
Inband signalling DCCH	2 kbps
Puncturing level at Code rate : 1/3 DCH of the DTCH / 1/2 DCH of the DCCH	43.8% / 13.3%

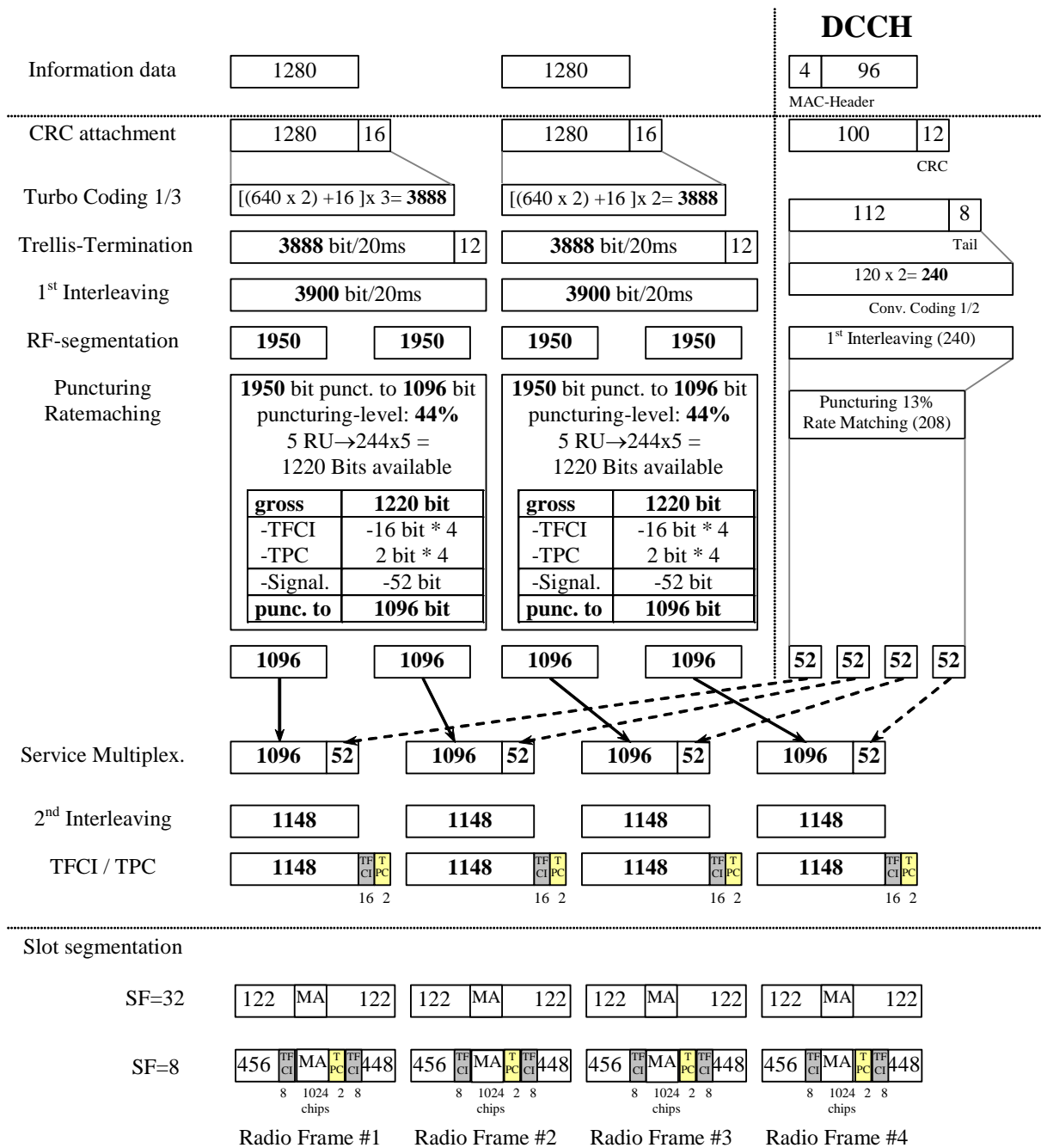

Figure A.2B

A.2.3 UL reference measurement channel (144 kbps)

A.2.3.1 3,84 Mcps TDD option

Table A.3

Parameter	Value
Information data rate	144 kbps
RU's allocated	1 SF2 + 1 SF16 = 9RU
Midamble	256 chips
Interleaving	20 ms
Power control	2 Bit/user
TFCI	16 Bit/user
Inband signalling DCCH	2 kbps
Puncturing level at Code rate : 1/3 DCH of the DTCH / 1/2 DCH of the DCCH	47.3% / 20%

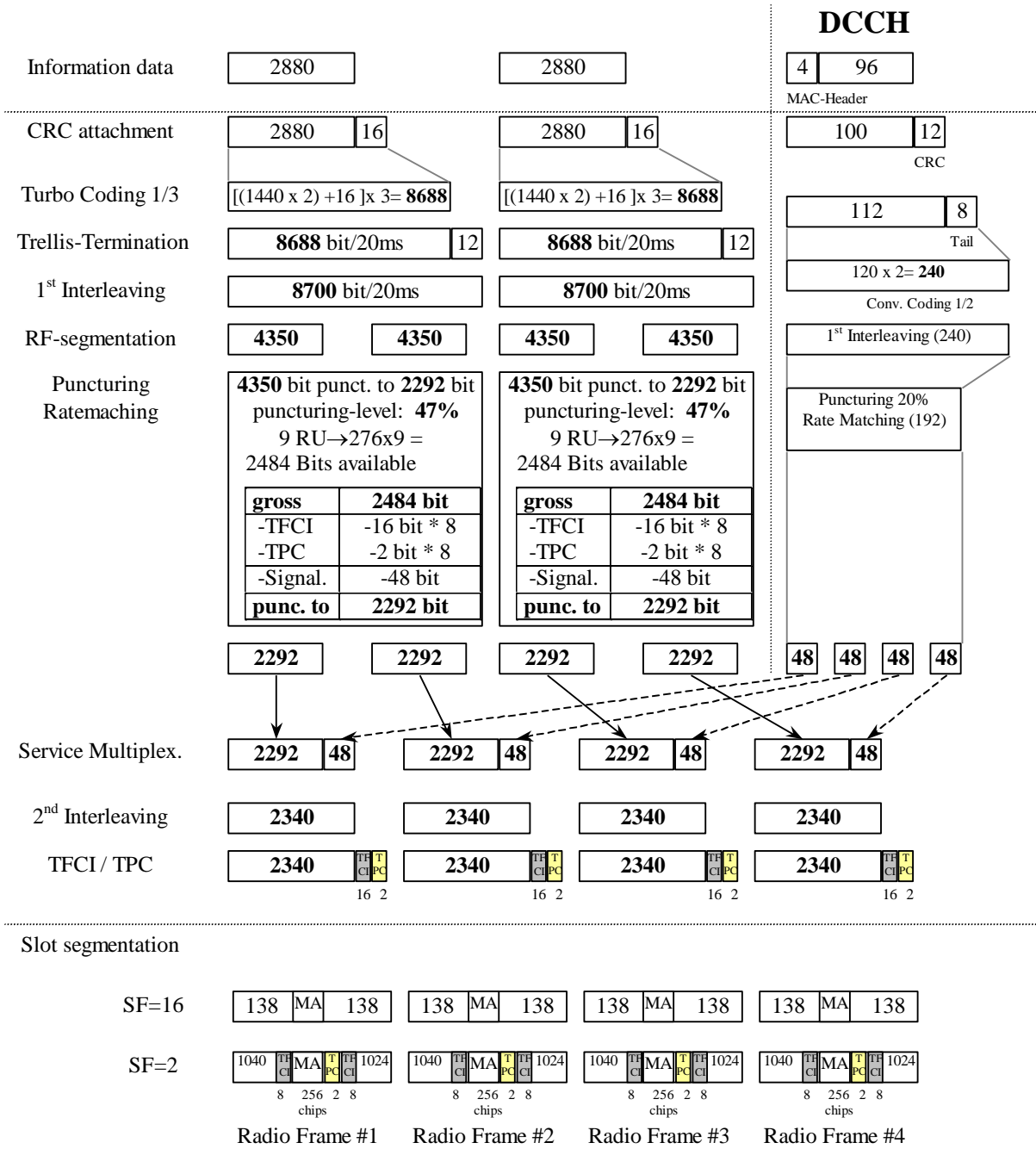

Figure A.3

A.2.3.2 1,28 Mcps TDD option

Table A.3A

Parameter	Value
Information data rate	144 kbps
RU's allocated	2TS (1*SF2) = 16RU/5ms
Midamble	144
Interleaving	20 ms
Power control (TPC)	8 Bit/user/10ms
TFCI	32 Bit/user/10ms
Synchronisation Shift (SS)	8 Bit/user/10ms
Inband signalling DCCH	2.4 kbps
Puncturing level at Code rate: 1/3 DCH of the DTCH / 1/2 DCH of the DCCH	38% / 7%

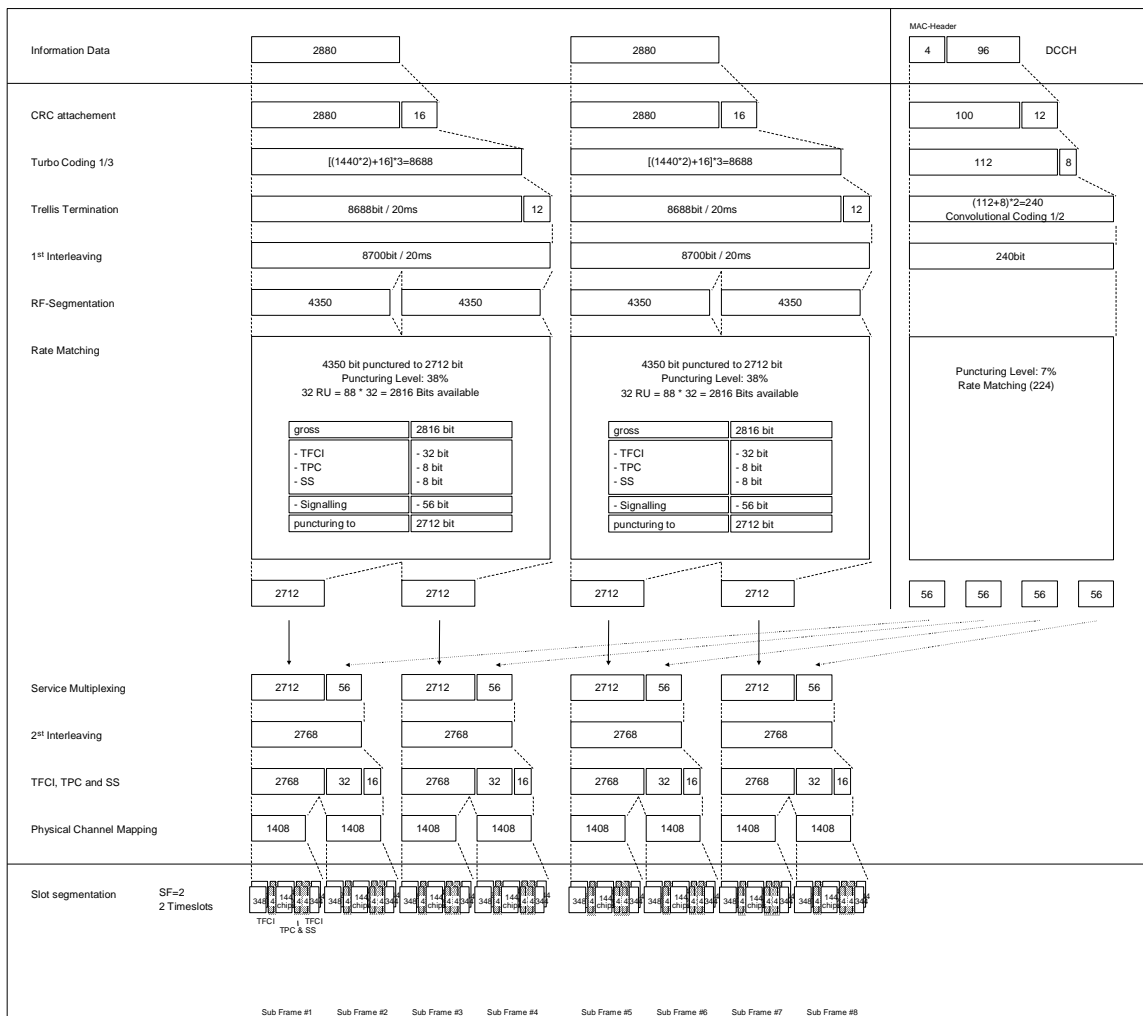

Figure A.3A

A.2.3.3 7,68 Mcps TDD Option

Table A.3B

Parameter	Value
Information data rate	144 kbps
RU's allocated	1 SF4 + 1 SF32 = 9RU
Midamble	512 chips
Interleaving	20 ms
Power control	2 Bit/user
TFCI	16 Bit/user
Inband signalling DCCH	2 kbps
Puncturing level at Code rate : 1/3 DCH of the DTCH / 1/2 DCH of the DCCH	47.3% / 20%

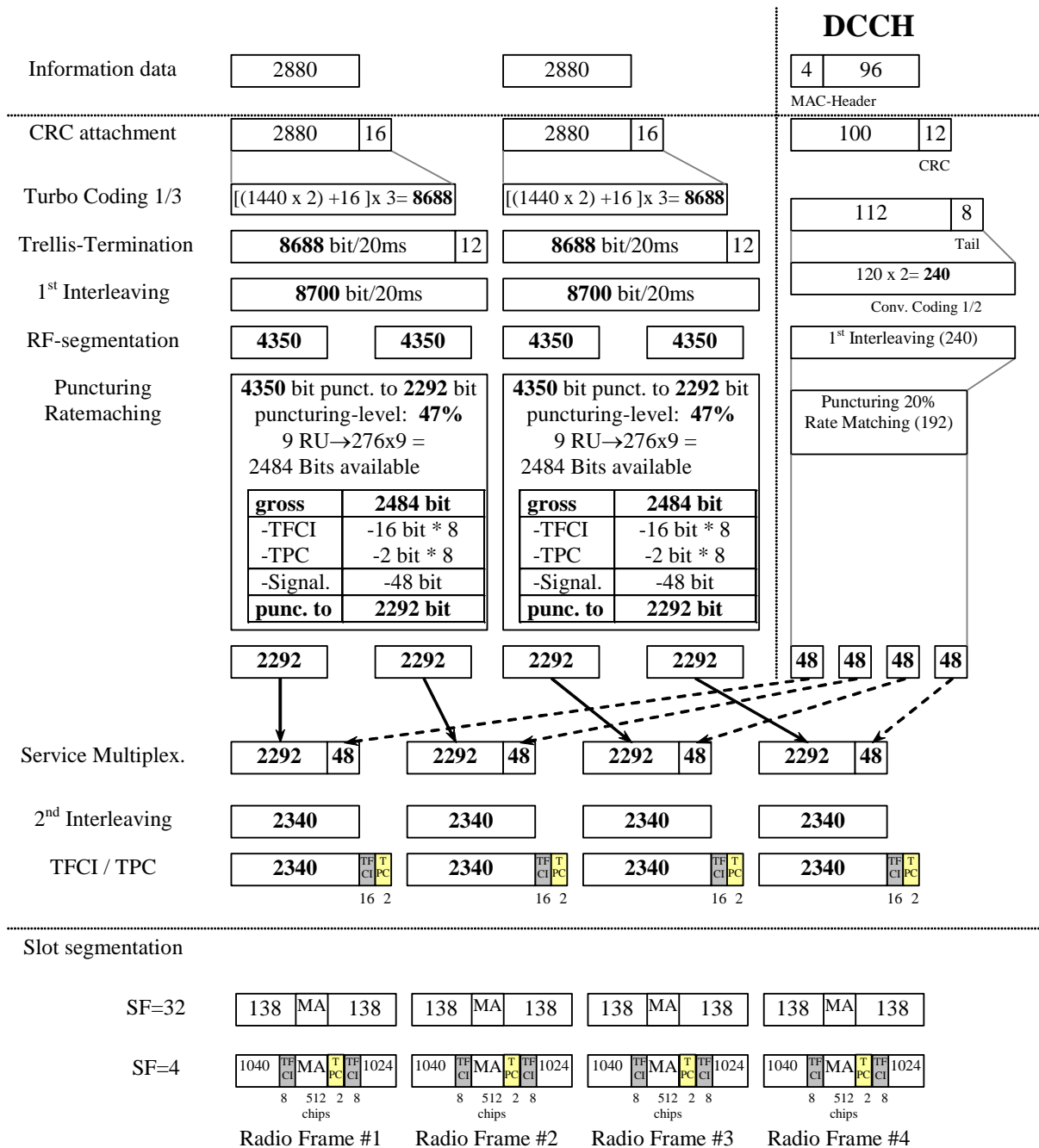

Figure A.3B

A.2.4 UL reference measurement channel (384 kbps)

A.2.4.1 3,84 Mcps TDD option

Table A.4

Parameter	Value
Information data rate	384 kbps
RU's allocated	$8 \times 3\text{TS} = 24\text{RU}$
Midamble	256 chips
Interleaving	20 ms
Power control	2 Bit/user
TFCI	16 Bit/user
Inband signalling DCCH	2 kbps
Puncturing level at Code rate : 1/3 DCH of the DTCH / 1/2 DCH of the DCCH	44% / 15.3%

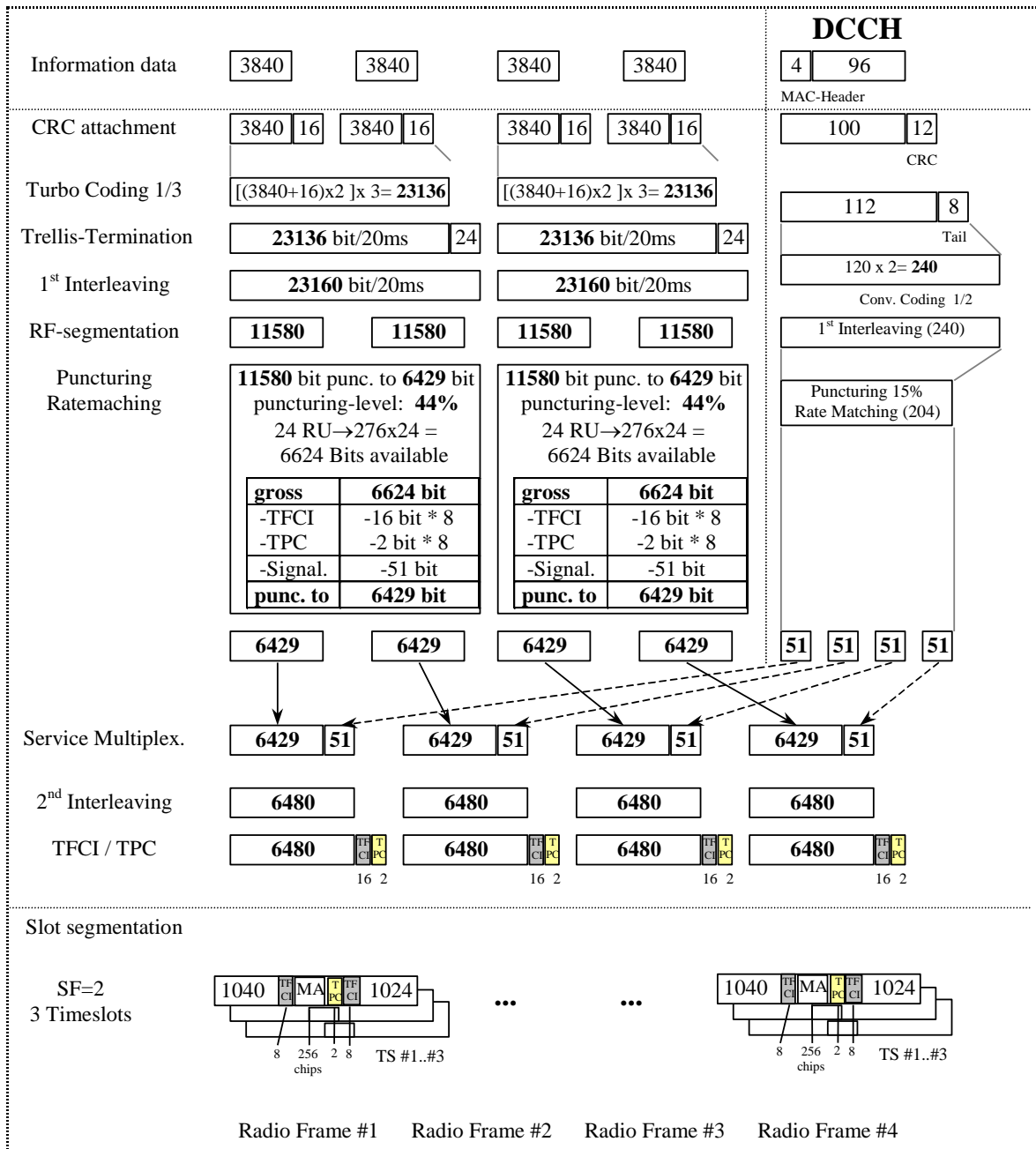

Figure A.4

A.2.4.2 1,28 Mcps TDD option

Table A.4A

Parameter	Value
Information data rate	384 kbps
RU's allocated	4TS (1*SF2 + 1*SF16) = 36RU/5ms
Midamble	144
Interleaving	20 ms
Power control (TPC)	16 Bit/user/10ms
TFCI	64 Bit/user/10ms
Synchronisation Shift (SS)	16 Bit/user/10ms
Inband signalling DCCH	2.4 kbps
Puncturing level at Code rate: 1/3 DCH of the DTCH / 1/2 DCH of the DCCH	47% / 12%

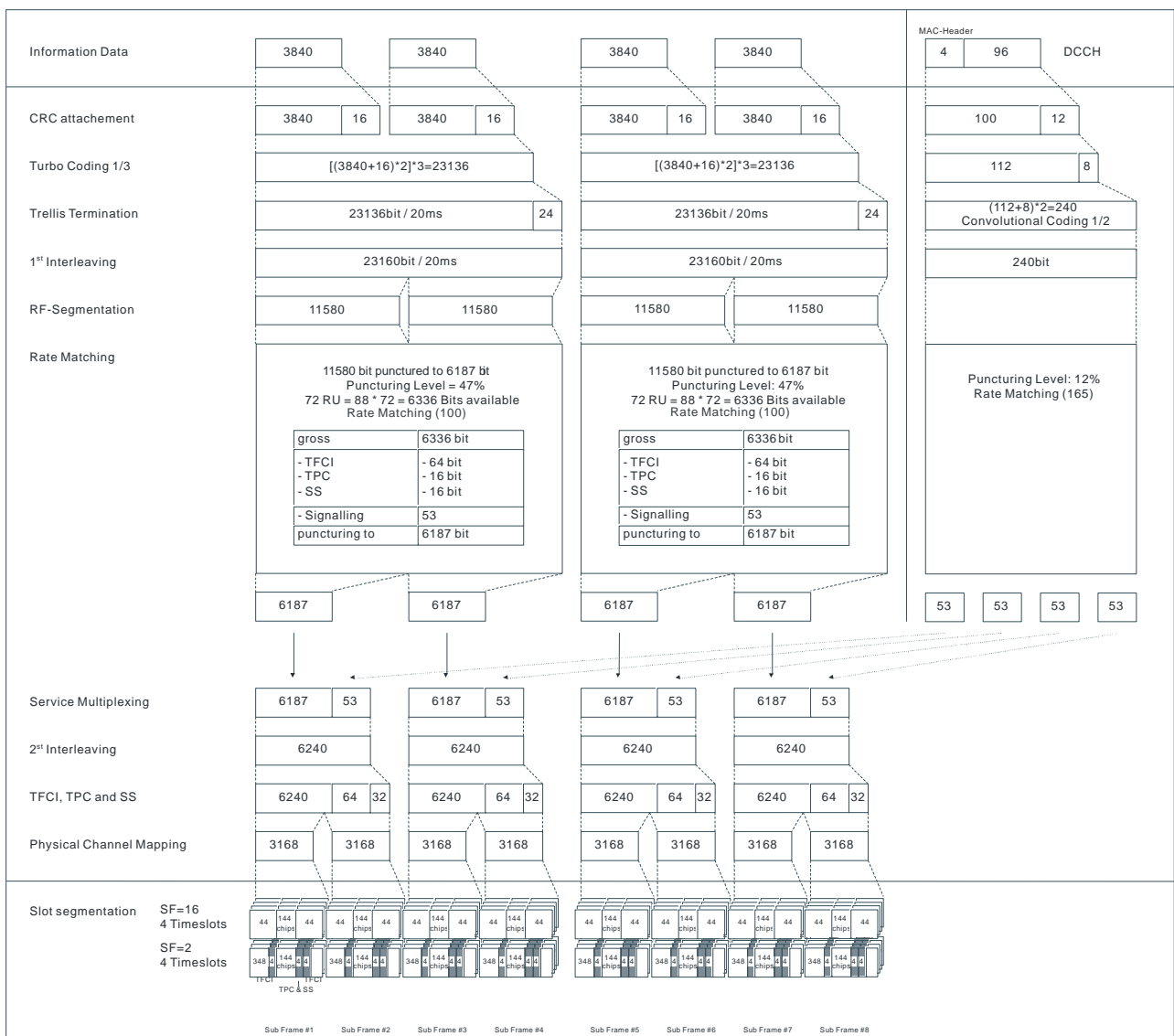

Figure A.4A

A.2.4.3 7,68 Mcps TDD Option

Table A.4B

Parameter	Value
Information data rate	384 kbps
RU's allocated	8*3TS = 24RU
Midamble	512 chips
Interleaving	20 ms
Power control	2 Bit/user
TFCI	16 Bit/user
Inband signalling DCCH	2 kbps
Puncturing level at Code rate : 1/3 DCH of the DTCH / 1/2 DCH of the DCCH	43.4% / 15.3%

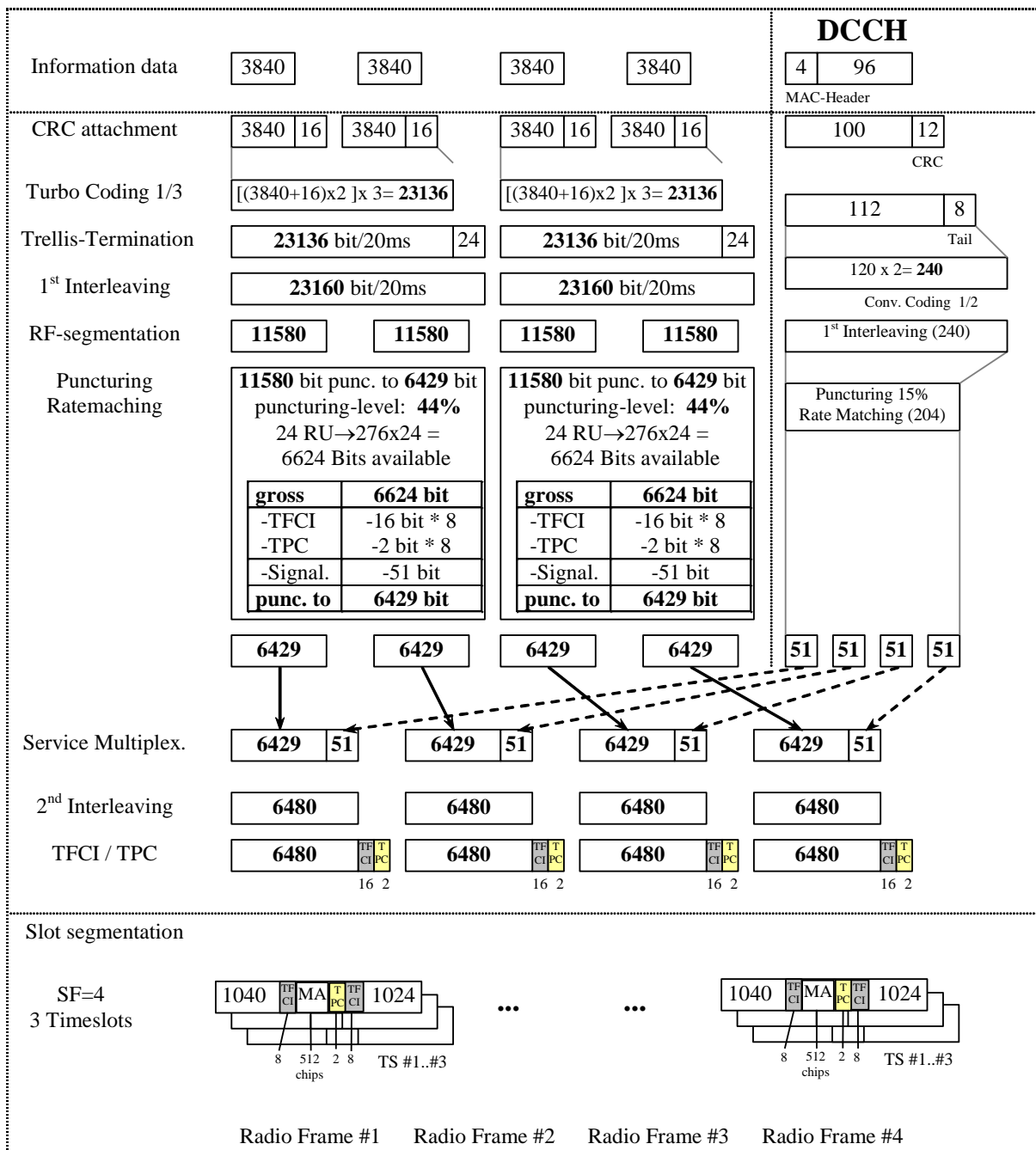

Figure A.4B

A.2.5 RACH reference measurement channel

A.2.5.1 3,84 Mcps TDD option

Table A.5

Parameter	Value
Information data rate e.g. 2 TBs ($B_{RACH}=2$): SF16: 0% puncturing rate at CR=1/2 10% puncturing rate at CR=1/2 $N_{RACH} = \frac{232 + N_{RM} - 8}{B_{RACH}} - 8$ SF8: 0% puncturing rate at CR=1/2 10% puncturing rate at CR=1/2 $N_{RACH} = \frac{464 + N_{RM} - 8}{B_{RACH}} - 16$	46 bits per frame and TB 53 bits per frame and TB 96 bits per frame and TB 109 bits per frame and TB
RU's allocated	1 RU
Midamble	512 chips
Power control	0 bit
TFCI	0 bit

N_{RACH} = number of bits per TB

B_{RACH} = number of TBs

A.2.5.1.1 RACH mapped to 1 code SF16

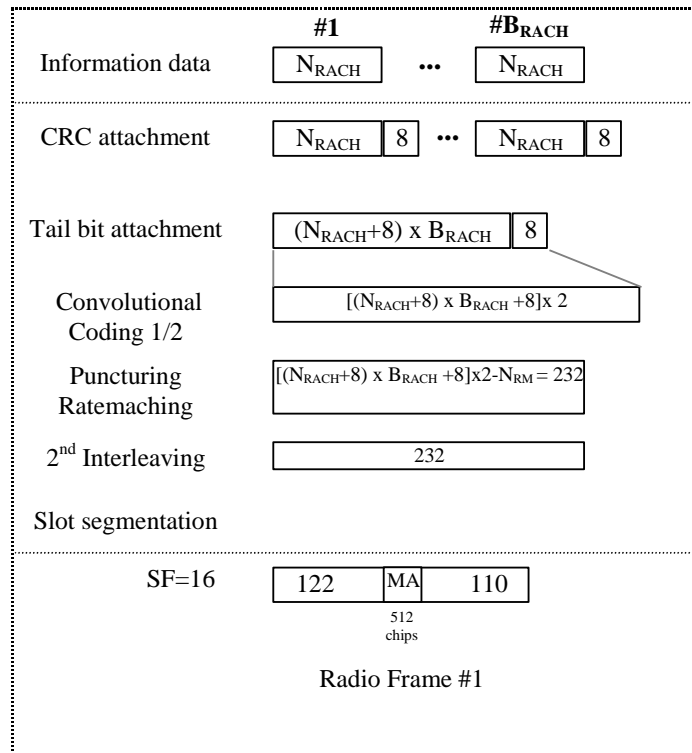

Figure A.5

A.2.5.1.2 RACH mapped to 1 code SF8

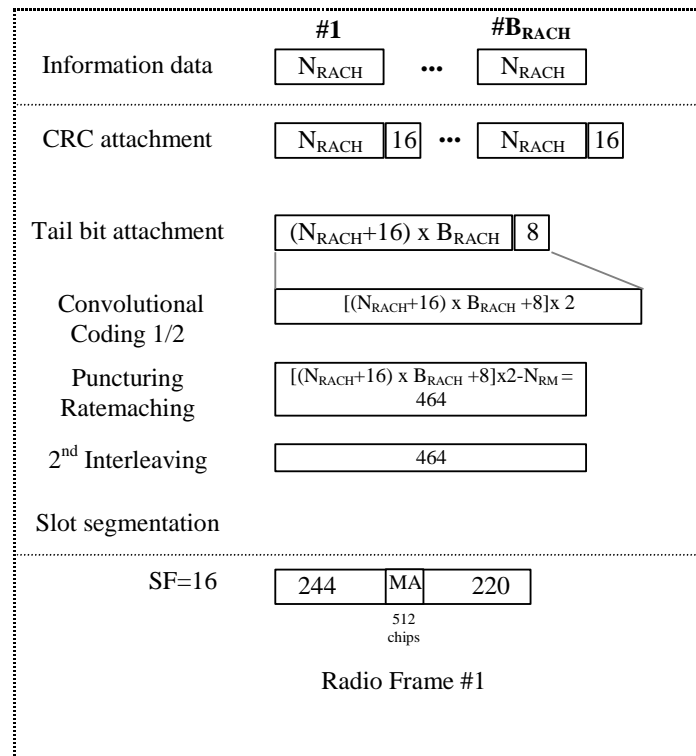

Figure A.6

A.2.5.2 1,28 Mcps TDD option

Table A5.A

Parameter	Value
Information data rate: $N_{RACH} = \frac{88 * \frac{16}{SF} \left(\frac{N_{RM}}{100} + 1 \right) - 8}{B_{RACH}} - 16$	Transport Block Set Size=1 CRC length = 16 Tail Bits = 8
SF16 (RU's allocated:1): 0% puncturing rate at CR=1/2 ~10% puncturing rate at CR=1/2	20 bits per frame and TB 24 bits per frame and TB
SF8 (RU's allocated:2): 0% puncturing rate at CR=1/2 ~10% puncturing rate at CR=1/2	64 bits per frame and TB 73 bits per frame and TB
SF4 (RU's allocated:4): 0% puncturing rate at CR=1/2 ~10% puncturing rate at CR=1/2	152 bits per frame and TB 170 bits per frame and TB
TTI	5msec
Midamble	144 chips
Power control	0 bit
TFCI	0 bit

N_{RACH} = number of bits per TB

B_{RACH} = number of TBs

N_{RM} = puncturing rate

A.2.5.2.1 RACH mapped to 1 code SF16

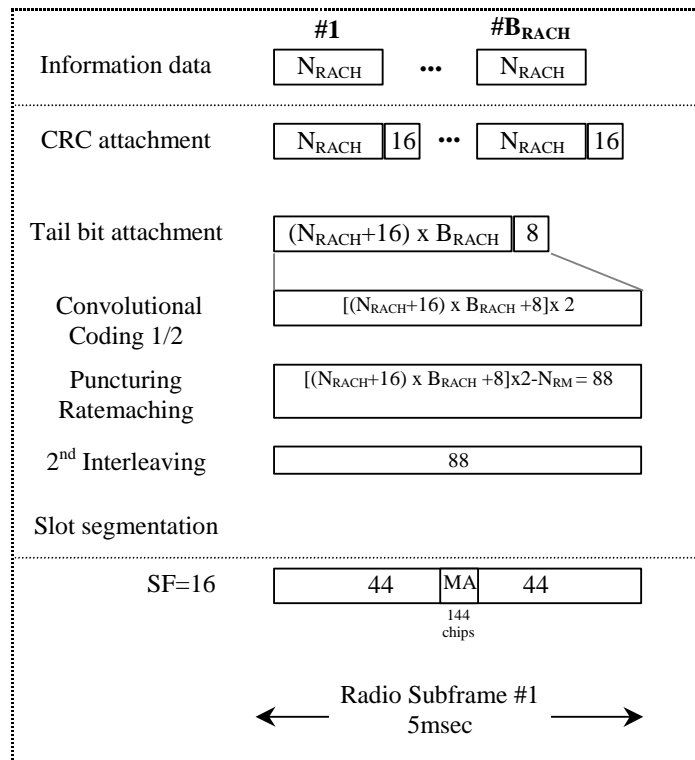

Figure A.5A

A.2.5.2.2 RACH mapped to 1 code SF8

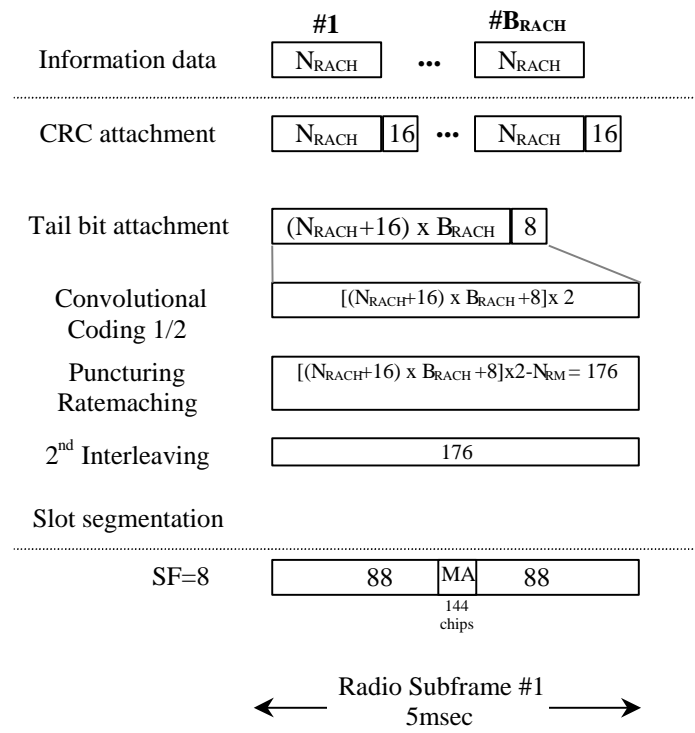

Figure A.6A

A.2.5.2.3 RACH mapped to 1 code SF4

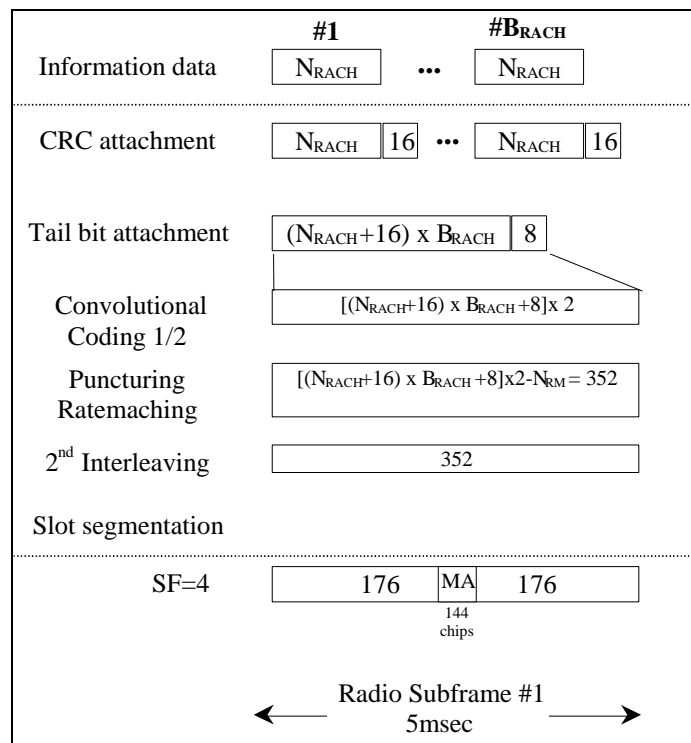

Figure A.7

A.2.5.3 7,68 Mcps TDD option

Table A5.B

Parameter	Value
Information data rate e.g. 2 TBs ($B_{RACH}=2$): SF32: 0% puncturing rate at CR=1/2 10% puncturing rate at CR=1/2 $N_{RACH} = \frac{232 + N_{RM} - 8}{B_{RACH}} - 8$	46 bits per frame and TB 53 bits per frame and TB
SF16: 0% puncturing rate at CR=1/2 10% puncturing rate at CR=1/2 $N_{RACH} = \frac{464 + N_{RM} - 8}{B_{RACH}} - 16$	96 bits per frame and TB 109 bits per frame and TB
RU's allocated	1 RU for SF32, 2 RUs for SF16
Midamble	1024 chips
Power control	0 bit
TFCI	0 bit

N_{RACH} = number of bits per TB

B_{RACH} = number of TBs

A.2.5.3.1 RACH mapped to 1 code SF16

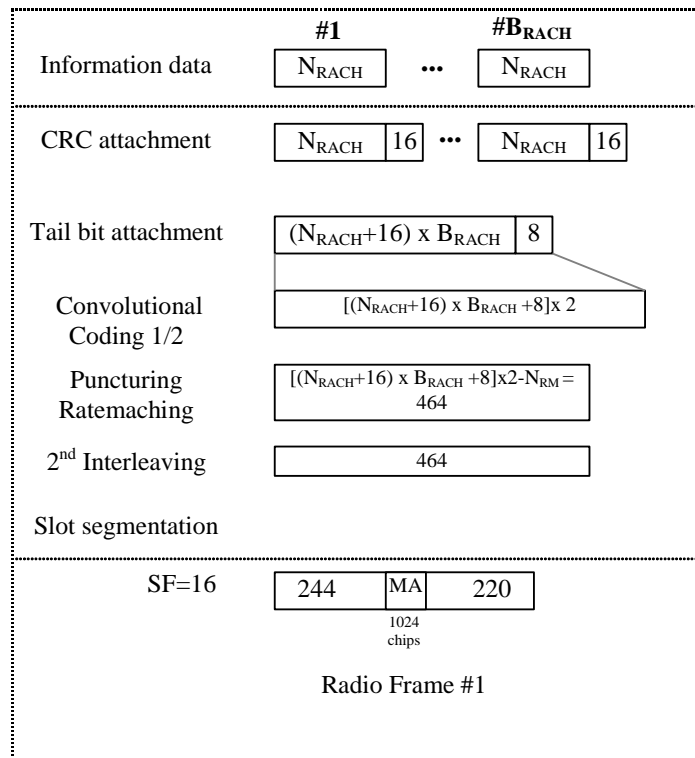

Figure A.8

A.2.5.3.2 RACH mapped to 1 code SF32

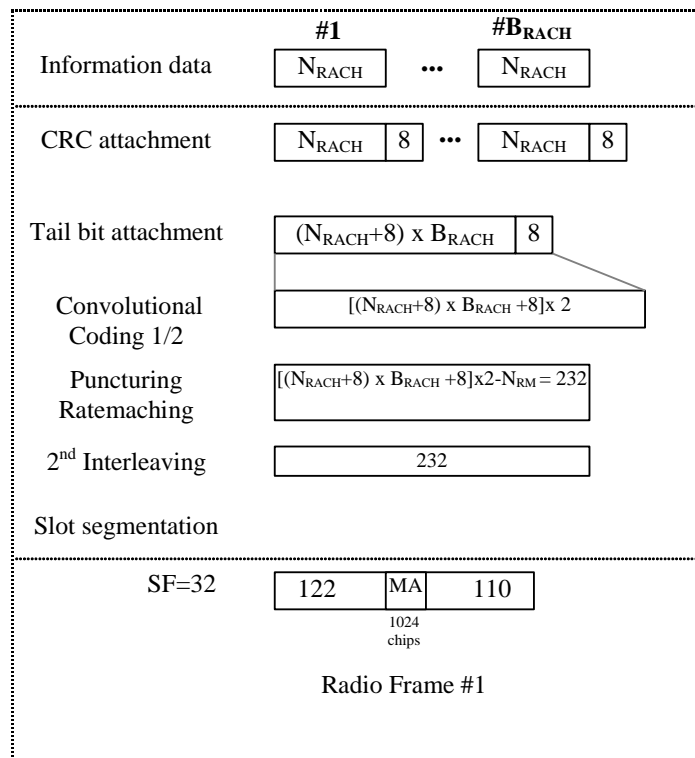

Figure A.9

A.3 E-DCH Reference measurement channels

A.3.1 E-DCH Fixed Reference Channels

A.3.1.1 3,84 Mcps TDD Option

A.3.1.1.1 Fixed Reference Channel 1 (FRC1)

Table A.6: E-DCH Fixed Reference Channel 1 (3,84 Mcps TDD Option)

Parameter	Unit	Value
Maximum information bit throughput	kbps	34.7
Information Bit Payload (N_{INF})	Bits	347
Number Code Blocks	Blocks	1
Number of coded bits per TTI	Bits	1200
Coding Rate		0.312
Modulation		QPSK
Number of E-DCH Timeslots	Slots	6
Number of E-DCH codes per TS	Codes	1
Spreading factor	SF	16
Number of E-UCCH per TTI		4

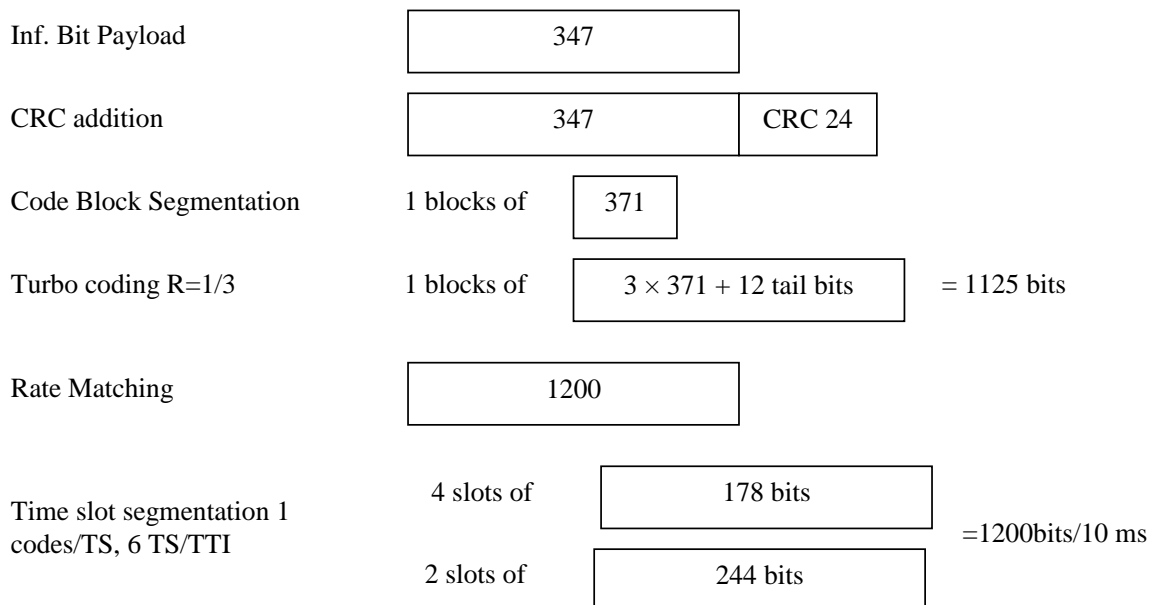

Figure A.10: Coding for E-DCH FRC1 (3,84 Mcps TDD Option)

A.3.1.1.2 Fixed Reference Channel 2 (FRC2)

Table A.7: E-DCH Fixed Reference Channel 2 (3,84 Mcps TDD Option)

Parameter	Unit	Value
Maximum information bit throughput	kbps	1083.1
Information Bit Payload (N_{INF})	Bits	10831
Number Code Blocks	Blocks	3
Number of coded bits per TTI	Bits	22272
Coding Rate		0.488
Modulation		16QAM
Number of E-DCH Timeslots	Slots	6
Number of E-DCH codes per TS	Codes	1
Spreading factor	SF	2
Number of E-UCCH per TTI		2

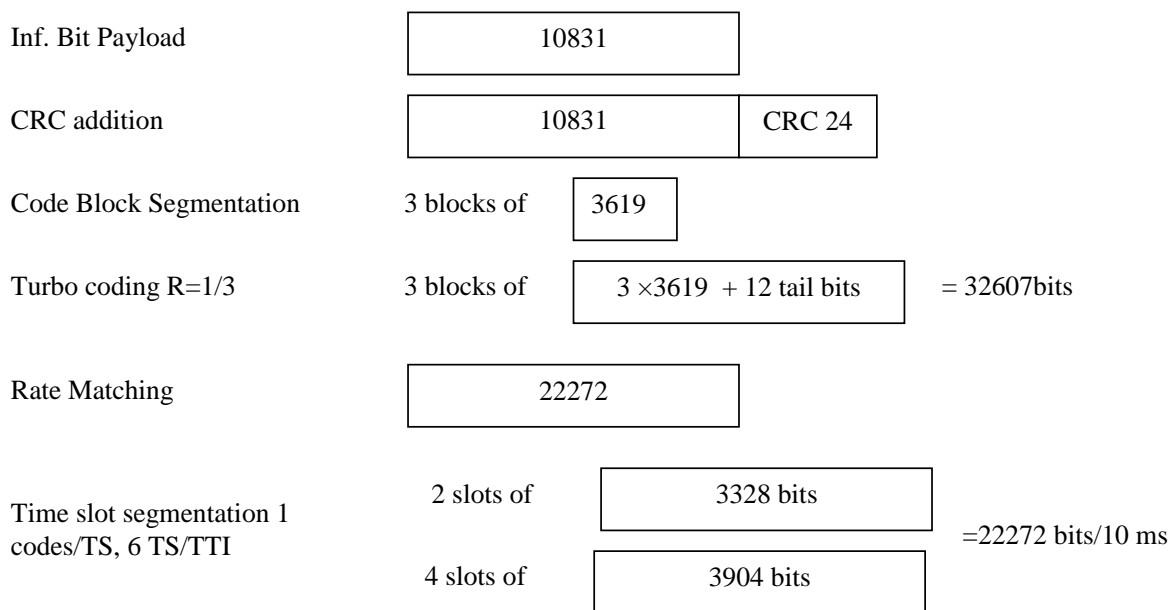

Figure A.11: Coding for E-DCH FRC2 (3,84 Mcps TDD Option)

A.3.1.1.3 Fixed Reference Channel 3 (FRC3)

Table A.8: E-DCH Fixed Reference Channel 3 (3,84 Mcps TDD Option)

Parameter	Unit	Value
Maximum information bit throughput	kbps	2073.7
Information Bit Payload (N_{INF})	Bits	20737
Number Code Blocks	Blocks	5
Number of coded bits per TTI	Bits	28992
Coding Rate		0.716
Modulation		16QAM
Number of E-DCH Timeslots	Slots	4
Number of E-DCH codes per TS	Codes	1
Spreading factor	SF	1
Number of E-UCCH per TTI		2

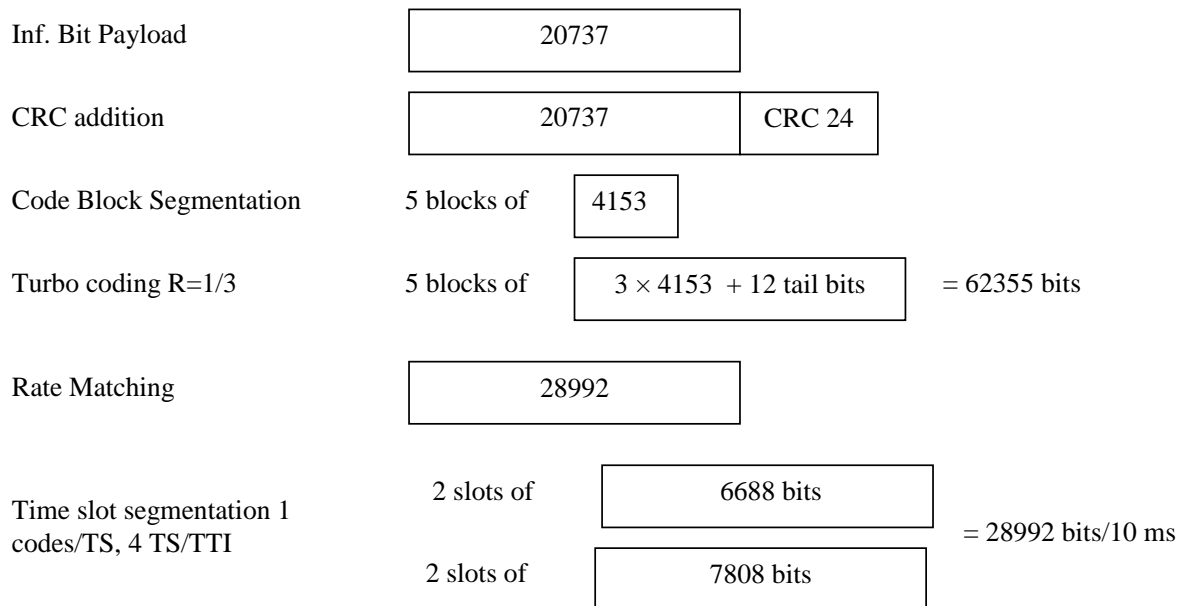

Figure A.12: Coding for E-DCH FRC3 (3,84 Mcps TDD Option)

A.3.1.2 1.28Mcps TDD Option

A.3.1.2.1 Fixed reference channel 1(FRC1)

Table A.9: E-DCH Fixed reference channel 1 (1.28Mcps TDD option)

Parameter	Unit	Value
Maximum information bit throughput	kbps	56.4
Information Bit Payload (N_{INF})	Bits	282
Number Code Blocks	Blocks	1
Number of coded bits per TTI	Bits	306
Coding Rate		0.4965
Modulation		QPSK
Number of E-DCH Timeslots	Slots	2
Number of E-DCH codes per TS	Codes	1
Spreading factor	SF	4
Number of E-UCCH per TTI		4

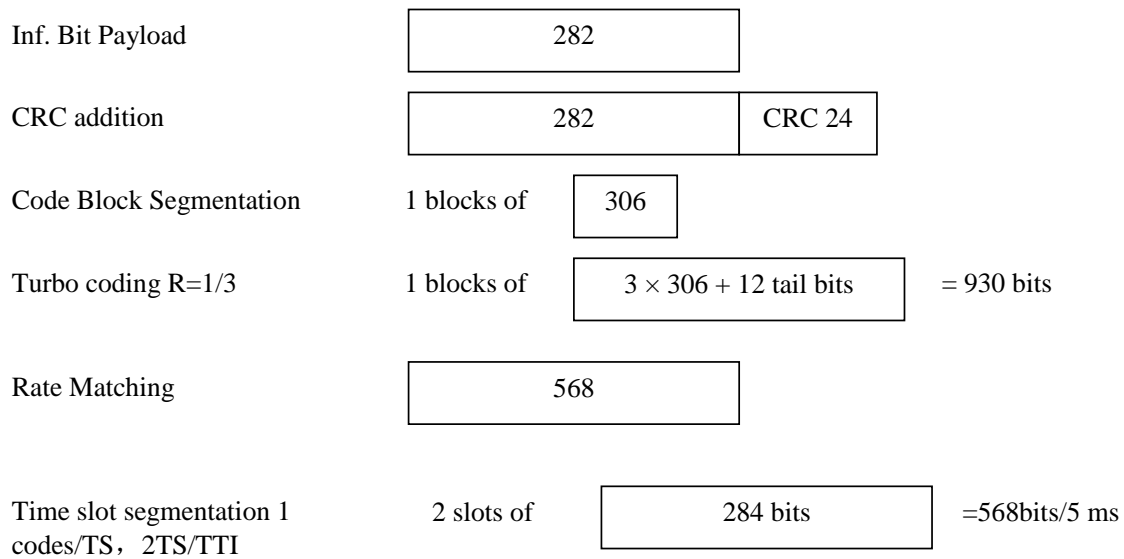

Figure A.12A: Coding for E-DCH FRC1 (1.28 Mcps TDD Option)

A.3.1.2.2 Fixed reference channel 2(FRC2)

Table A.10: E-DCH Fixed reference channel 2(1.28Mcps TDD option)

Parameter	Unit	Value
Maximum information bit throughput	kbps	227.8
Information Bit Payload (N_{INF})	Bits	1139
Number Code Blocks	Blocks	1
Number of coded bits per TTI	Bits	1163
Coding Rate		0.85
Modulation		QPSK
Number of E-DCH Timeslots	Slots	2
Number of E-DCH codes per TS	Codes	1
Spreading factor	SF	2
Number of E-UCCH per TTI		2

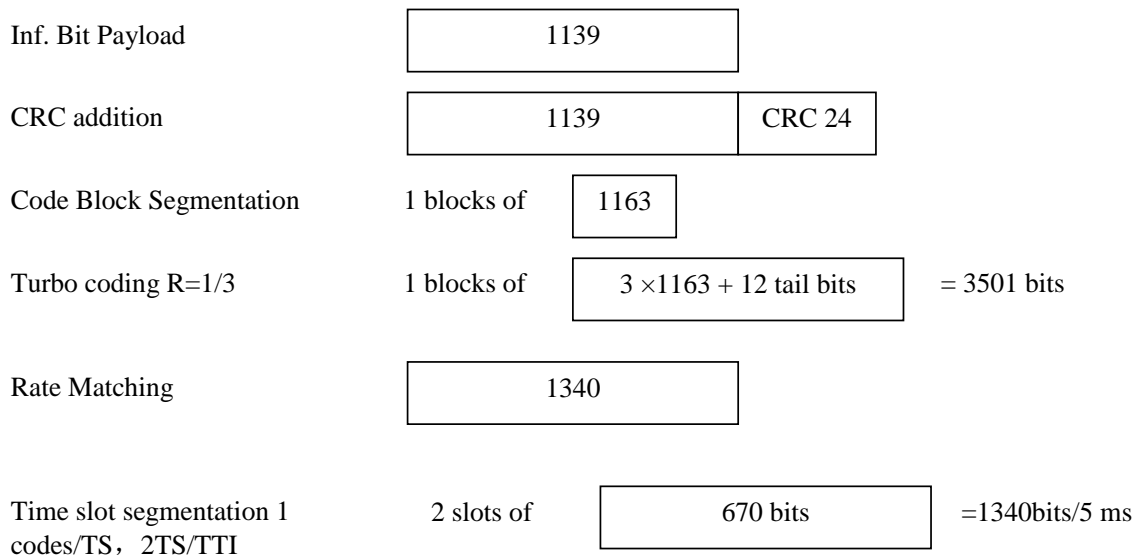

Figure A.13: Coding for E-DCH FRC2 (1.28 Mcps TDD Option)

A.3.1.2.3 Fixed reference channel 3(FRC3)

Table A.11: E-DCH Fixed reference channel 3 (1.28Mcps TDD option)

Parameter	Unit	Value
Maximum information bit throughput	kbps	489
Information Bit Payload (N_{INF})	Bits	2445
Number Code Blocks	Blocks	1
Number of coded bits per TTI	Bits	2469
Coding Rate		0.598
Modulation		16QAM
Number of E-DCH Timeslots	Slots	3
Number of E-DCH codes per TS	Codes	1
Spreading factor	SF	2
Number of E-UCCH per TTI		2

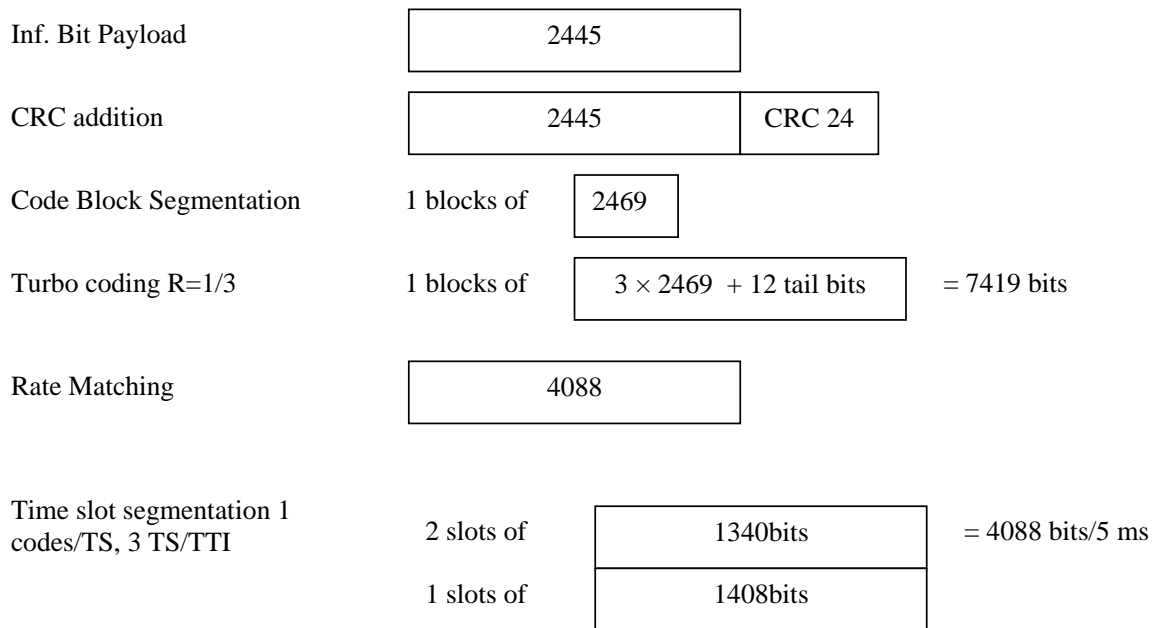

Figure A.14: Coding for E-DCH FRC3 (1.28 Mcps TDD Option)

A.3.1.2.4 Fixed reference channel 4(FRC4)

Table A.12: E-DCH Fixed reference channel 4 (1.28Mcps TDD option)

Parameter	Unit	Value
Maximum information bit throughput	kbps	1281.2
Information Bit Payload (N_{INF})	Bits	6406
Number Code Blocks	Blocks	2
Number of coded bits per TTI	Bits	6430
Coding Rate		0.5757
Modulation		16QAM
Number of E-DCH Timeslots	Slots	4
Number of E-DCH codes per TS	Codes	1
Spreading factor	SF	1
Number of E-UCCH per TTI		2

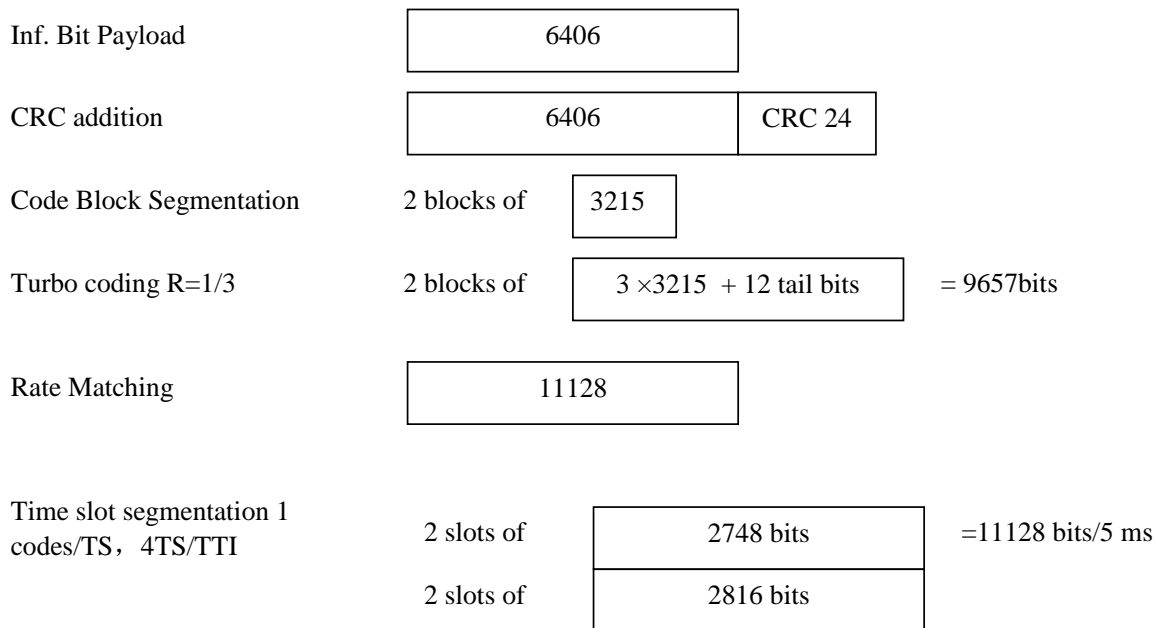

Figure A.15: Coding for E-DCH FRC4 (1.28 Mcps TDD Option)

A.3.1.3 7,68 Mcps TDD Option

A.3.1.3.1 Fixed Reference Channel 1 (FRC1)

Table A.13: E-DCH Fixed Reference Channel 1 (7.68 Mcps TDD Option)

Parameter	Unit	Value
Maximum information bit throughput	kbps	35.9
Information Bit Payload (N_{INF})	Bits	359
Number Code Blocks	Blocks	1
Number of coded bits per TTI	Bits	1200
Coding Rate		0.323
Modulation		QPSK
Number of E-DCH Timeslots	Slots	6
Number of E-DCH codes per TS	Codes	1
Spreading factor	SF	32
Number of E-UCCH per TTI		4

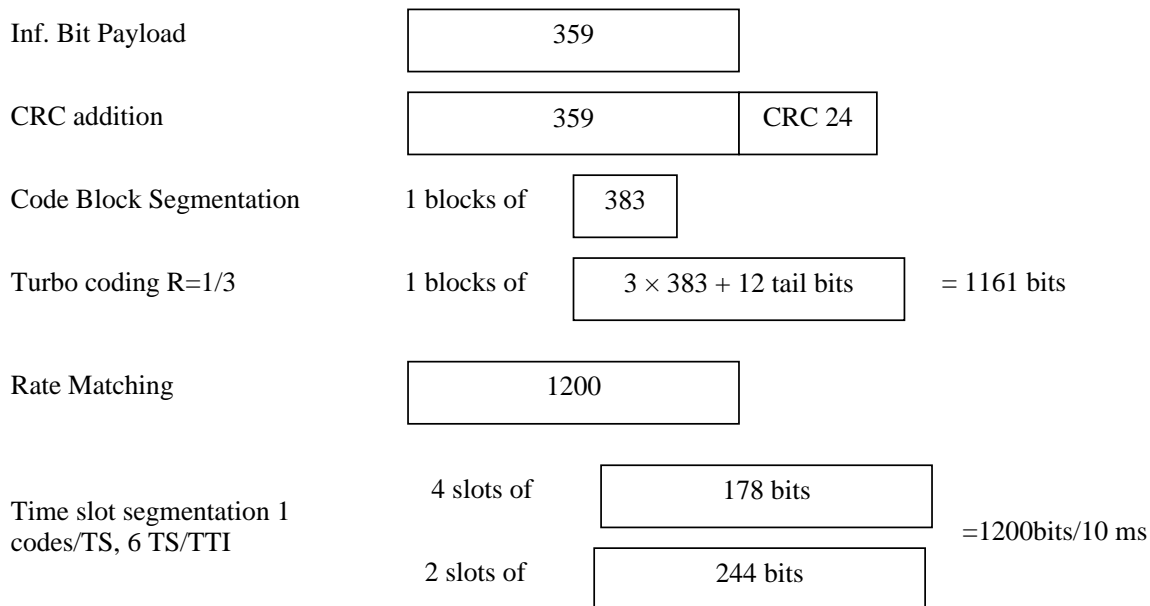

Figure A.16: Coding for E-DCH FRC1 (7.68 Mcps TDD Option)

A.3.1.3.2 Fixed Reference Channel 2 (FRC2)

Table A.14: E-DCH Fixed Reference Channel 2 (7.68 Mcps TDD Option)

Parameter	Unit	Value
Maximum information bit throughput	kbps	1083.1
Information Bit Payload (N_{INF})	Bits	10831
Number Code Blocks	Blocks	3
Number of coded bits per TTI	Bits	22272
Coding Rate		0.488
Modulation		16QAM
Number of E-DCH Timeslots	Slots	6
Number of E-DCH codes per TS	Codes	1
Spreading factor	SF	4
Number of E-UCCH per TTI		2

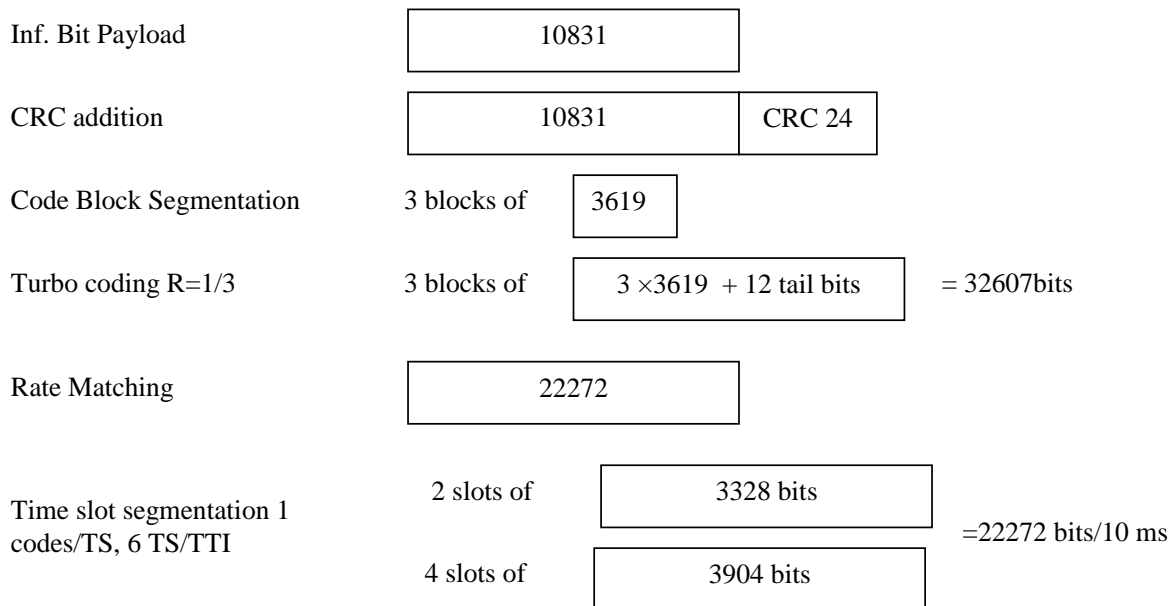

Figure A.17: Coding for E-DCH FRC2 (7.68 Mcps TDD Option)

A.3.1.3.3 Fixed Reference Channel 3 (FRC3)

Table A.15: E-DCH Fixed Reference Channel 3 (7.68 Mcps TDD Option)

Parameter	Unit	Value
Maximum information bit throughput	kbps	2085.1
Information Bit Payload (N_{INF})	Bits	20851
Number Code Blocks	Blocks	5
Number of coded bits per TTI	Bits	28992
Coding Rate		0.720
Modulation		16QAM
Number of E-DCH Timeslots	Slots	6
Number of E-DCH codes per TS	Codes	1
Spreading factor	SF	2
Number of E-UCCH per TTI		2

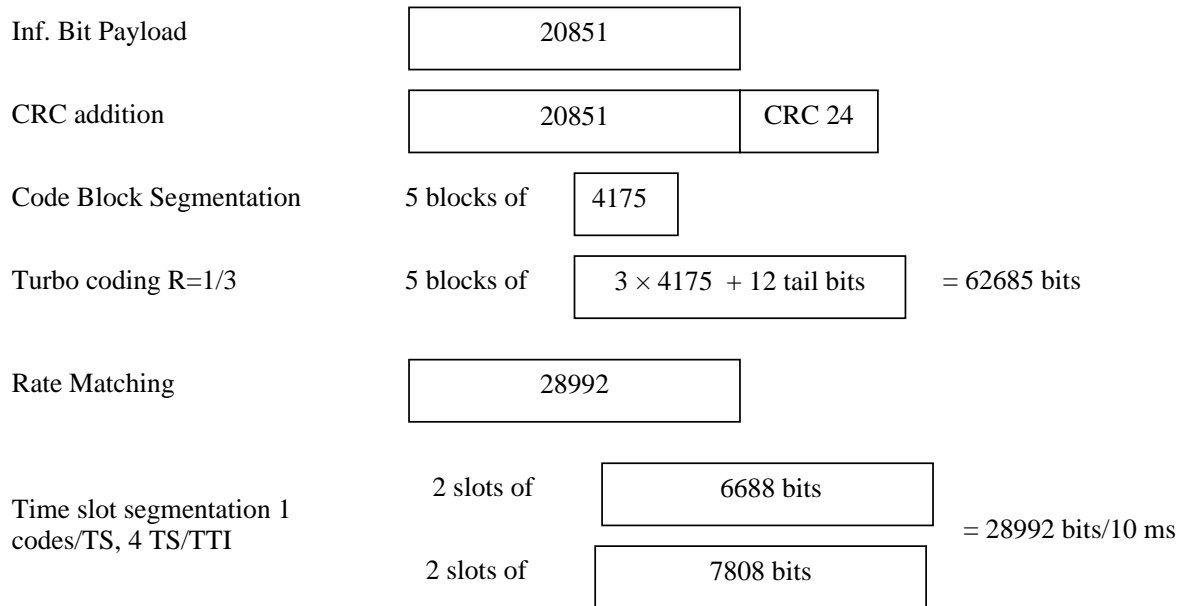

Figure A.18: Coding for E-DCH FRC3 (7.68 Mcps TDD Option)

A.4 HS-SICH Reference measurement channels

A.4.1 3,84 Mcps TDD Option

(void)

A.4.2 1,28 Mcps TDD Option

Table A.16: HS-SICH type1 Reference Channel 1 (1,28 Mcps TDD Option)

Parameter	Unit	Value
Information bits	bits	8
Encoded bits	bits	84
Number of codes	-	1
Number of timeslots	-	1
TTI	ms	5
Spreading Factor	SF	16

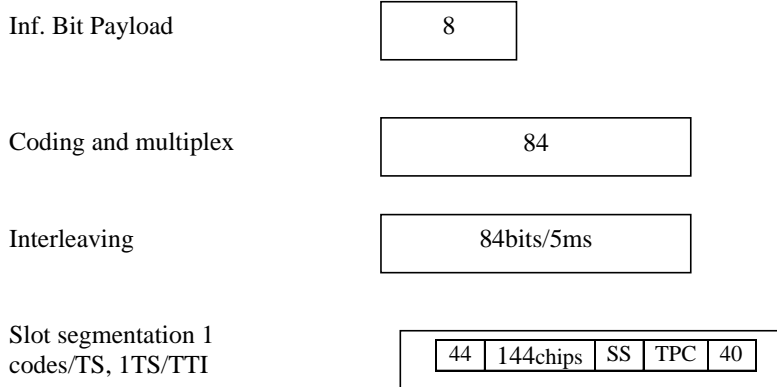

Figure A.19: Coding for HS-SICH type1 channel (1,28 Mcps TDD Option)

Table A.17: HS-SICH type2 Reference Channel 1 (1.28 Mcps TDD Option)

Parameter	Unit	Value
Information bits	bits	16
Encoded bits	bits	168
Number of codes	-	1
Number of timeslots	-	1
TTI	ms	5
Spreading Factor	SF	8

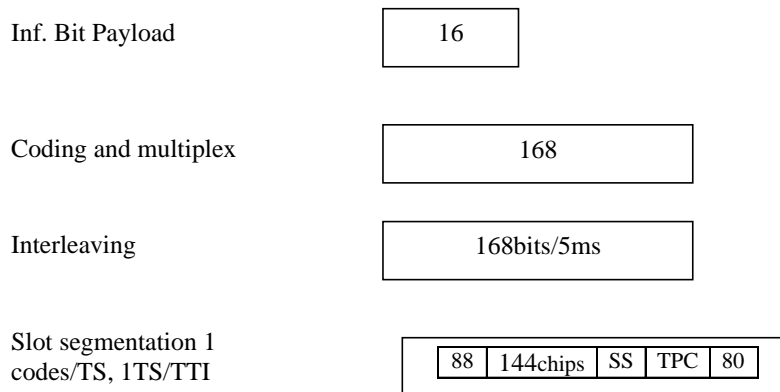

Figure A.20: Coding for HS-SICH type2 channel (1.28 Mcps TDD Option)

Annex B (normative): Propagation conditions

B.1 Static propagation condition

The propagation for the static performance measurement is an Additive White Gaussian Noise (AWGN) environment. No fading and multi-paths exist for this propagation model.

B.2 Multi-path fading propagation conditions

B.2.1 3,84 Mcps TDD option

Table B.1 and B.1A shows propagation conditions that are used for the performance measurements in multi-path fading environment. All taps have classical Doppler spectrum, defined as:

$$(CLASS) \quad S(f) \propto 1/(1 - (f / f_D)^2)^{0.5} \quad \text{for } f \in [-f_D, f_D]$$

Table B.1: Propagation Conditions for Multi path Fading Environments for 3,84 Mcps TDD option for operations referenced in 4.2 a), 4.2 b) and 4.2 c)

Case 1, speed 3km/h		Case 2, speed 3 km/h		Case 3, speed 120 km/h	
Relative Delay [ns]	Relative Mean Power [dB]	Relative Delay [ns]	Relative Mean Power [dB]	Relative Delay [ns]	Relative Mean Power [dB]
0	0	0	0	0	0
976	-10	976	0	260	-3
		12000	0	521	-6
				781	-9

Table B.1A: Propagation Conditions for Multi path Fading Environments for operations referenced in 4.2 d)

Case 1, speed 2.3km/h		Case 2, speed 2.3 km/h		Case 3, speed 92 km/h	
Relative Delay [ns]	Relative Mean Power [dB]	Relative Delay [ns]	Relative Mean Power [dB]	Relative Delay [ns]	Relative Mean Power [dB]
0	0	0	0	0	0
976	-10	976	0	260	-3
		12000	0	521	-6
				781	-9

B.2.2 1,28 Mcps TDD option

Table B2.2 shows propagation conditions that are used for the performance measurements in multi-path fading environment. All taps have classical Doppler spectrum, defined as:

$$(CLASS) \quad S(f) \propto 1/(1 - (f / f_D)^2)^{0.5} \quad \text{for } f \in [-f_D, f_D]$$

Table B2: Propagation Conditions for Multi path Fading Environments

Case 1		Case 2		Case 3	
Speed for operating in band a, b, c, f 3km/h		Speed for operating in band a, b, c, f: 3km/h		Speed for operating in band a, b, c, f: 120km/h	
Speed for operating in band d: 2.3km/h		Speed for operating in band d: 2.3km/h		Speed for operating in band d: 92km/h	
Speed for operating in band e: 2.6km/h		Speed for operating in band e: 2.6km/h		Speed for operating in band e: 102km/h	
Relative Delay [ns]	Relative Mean Power [dB]	Relative Delay [ns]	Relative Mean Power [dB]	Relative Delay [ns]	Relative Mean Power [dB]
0	0	0	0	0	0
2928	-10	2928	0	781	-3
		12000	0	1563	-6
				2344	-9

Table B.2A: Propagation Conditions for Multipath Fading Environments for E-DCH Performance Requirements for 1,28 Mcps TDD

ITU Pedestrian A Speed 3km/h (PA3)		ITU Pedestrian B Speed 3km/h (PB3)		ITU vehicular A Speed 30km/h (VA30)	
Speed for operating in band a, b, c, f: 3km/h		Speed for operating in band a, b, c, f 3km/h		Speed for operating in band a, b, c, f: 30km/h	
Speed for operating in band d: 2.3km/h		Speed for operating in band d: 2.3km/h		Speed for operating in band d: 23km/h	
Speed for operating in band e: 2.6km/h		Speed for operating in band e: 2.6km/h		Speed for operating in band e: 26km/h	
Relative Delay [ns]	Relative Mean Power [dB]	Relative Delay [ns]	Relative Mean Power [dB]	Relative Delay [ns]	Relative Mean Power [dB]
0	0	0	0	0	0
110	-9.7	200	-0.9	310	-1.0
190	-19.2	800	-4.9	710	-9.0
410	-22.8	1200	-8.0	1090	-10.0
		2300	-7.8	1730	-15.0
		3700	-23.9	2510	-20.0

Note: For MC-HSUPA requirements, the fading of the signals for each carrier shall be independent.

B.2.3 7,68 Mcps TDD option

Table B.4 and B.5 shows propagation conditions that are used for the performance measurements in multi-path fading environment. All taps have classical Doppler spectrum, defined as:

$$(CLASS) \quad S(f) \propto 1/(1 - (f/f_D)^2)^{0.5} \quad \text{for } f \in -f_d, f_d.$$

Table B.3: Propagation Conditions for Multi path Fading Environments for 3,84 Mcps TDD option for operations referenced in 4.2 a), 4.2 b) and 4.2 c)

Case 1, speed 3km/h		Case 2, speed 3 km/h		Case 3, speed 120 km/h	
Relative Delay [ns]	Relative Mean Power [dB]	Relative Delay [ns]	Relative Mean Power [dB]	Relative Delay [ns]	Relative Mean Power [dB]
0	0	0	0	0	0
976	-10	976	0	260	-3
		12000	0	521	-6
				781	-9

Table B.5: Propagation Conditions for Multi path Fading Environments for operations referenced in 4.2 d)

Case 1, speed 2.3km/h		Case 2, speed 2.3 km/h		Case 3, speed 92 km/h	
Relative Delay [ns]	Relative Mean Power [dB]	Relative Delay [ns]	Relative Mean Power [dB]	Relative Delay [ns]	Relative Mean Power [dB]
0	0	0	0	0	0
976	-10	976	0	260	-3
		12000	0	521	-6
				781	-9

B.3 High speed train conditions

High speed train conditions are as follows:

Scenario 1: Open space

Scenario 3: Tunnel for multi-antennas

The high speed train conditions for the test of the baseband performance are two non-fading propagation channels in both scenarios.

Doppler shift for both scenarios is given by:

$$f_s(t) = f_d \cos \theta(t) \quad (\text{B.1})$$

where $f_s(t)$ is the Doppler shift and f_d is the maximum Doppler frequency. The cosine of angle $\theta(t)$ is given by:

$$\cos \theta(t) = \frac{D_s/2 - vt}{\sqrt{D_{\min}^2 + (D_s/2 - vt)^2}}, \quad 0 \leq t \leq D_s/v \quad (\text{B.2})$$

$$\cos \theta(t) = \frac{-1.5D_s + vt}{\sqrt{D_{\min}^2 + (-1.5D_s + vt)^2}}, \quad D_s/v < t \leq 2D_s/v \quad (\text{B.3})$$

$$\cos \theta(t) = \cos \theta(t \bmod (2D_s/v)), \quad t > 2D_s/v \quad (\text{B.4})$$

where $D_s/2$ is the initial distance of the train from BS, and D_{\min} is BS-Railway track distance, both in meters; v is the velocity of the train in m/s, t is time in seconds.

Doppler shift and cosine angle is given by equation B.1 and B.2-B.4 respectively, where the required input parameters listed in table B.6 and the resulting Doppler shift shown in Figure B.1 and B.2 are applied for all frequency bands.

Table B.6: Parameters for high speed train conditions

Parameter	Value	
	Scenario 1	Scenario 3
D_s	1000 m	300 m
D_{min}	50 m	2 m
v	350 km/h	300 km/h
f_d	1310 Hz	1125 Hz

NOTE1: Parameters for HST conditions in table B. including f_d and Doppler shift trajectories presented on figures B.1 and B.2 were derived for Band a).

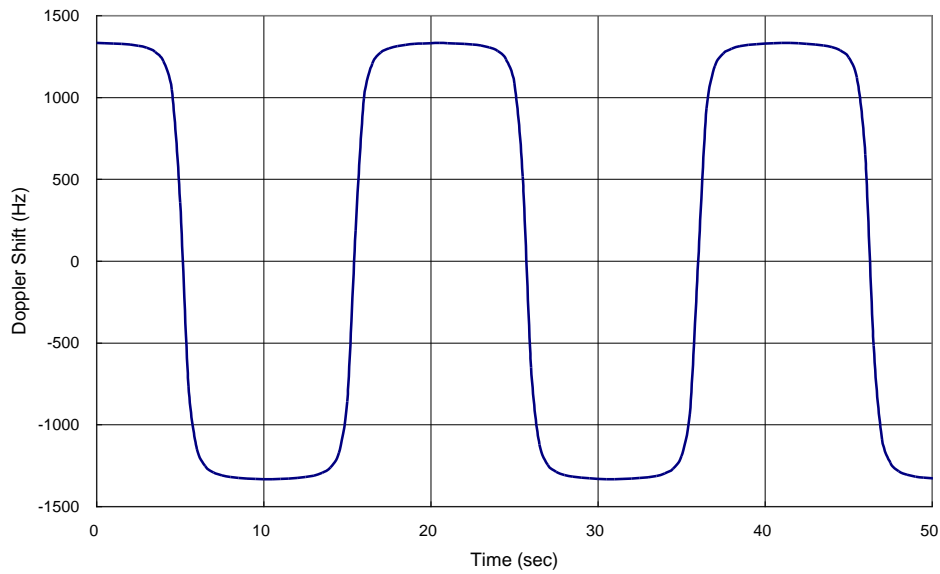

Figure B.1: Doppler shift trajectory for scenario 1

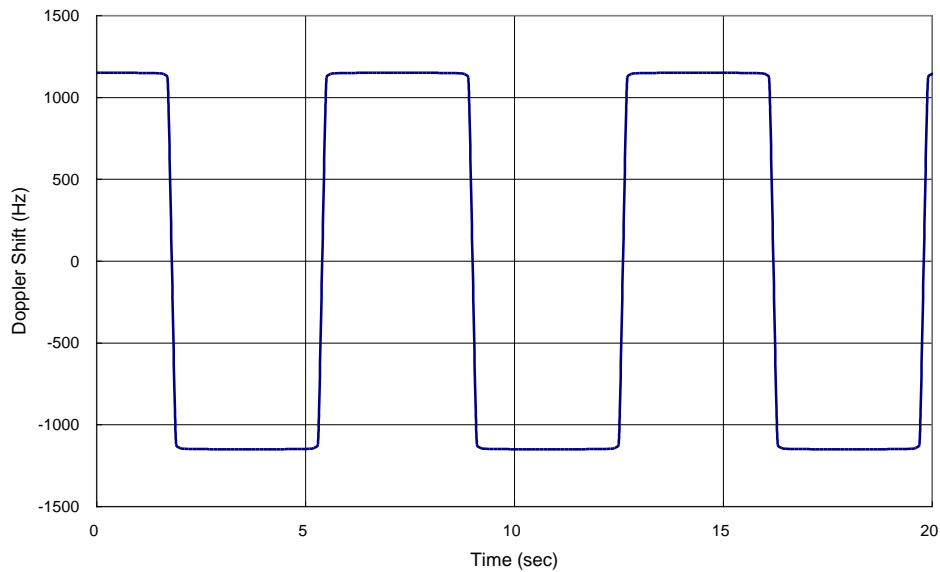

Figure B.2: Doppler shift trajectory for scenario 3

Annex C (normative): Global in-channel Tx test

C.1 General

The global in-channel Tx test enables the measurement of all relevant parameters that describe the in-channel quality of the output signal of the Tx under test in a single measurement process.

The parameters describing the in-channel quality of a transmitter, however, are not necessarily independent. The algorithm chosen for description inside this annex places particular emphasis on the exclusion of all interdependencies among the parameters. Any other algorithm (e.g. having better computational efficiency) may be applied, as long as the results are the same within the accuracy limits.

All notes referred to in the various subclauses of C.2 are put together in clause C.3

C.2 Definition of the process

C.2.1 Basic principle

The process is based on the comparison of the actual **output signal of the Tx under test**, received by an ideal receiver, with a **reference signal**, that is generated by the measuring equipment and represents an ideal error free received signal. The reference signal shall be composed of the same number of codes at the correct spreading factors as contained in the test signal. Note, for simplification, the notation below assumes only codes of one spreading factor although the algorithm is valid for signals containing multiple spreading factors. All signals are represented as equivalent (generally complex) base band signals.

C.2.2 Output signal of the Tx under test

The output signal of the Tx under test is acquired by the measuring equipment, filtered by a matched filter (RRC characteristic with roll-off $\alpha = 0,22$, correct in shape and in position on the frequency axis) and stored for further processing.

The following form represents the physical signal in the entire measurement interval:

one vector **Z**, containing $N = n_s \times sf + m_a$ complex samples;

with

- ns: number of symbols in the measurement interval;
- sf: number of chips per symbol. (sf: spreading factor) (see Note: Symbol length)
- ma: number of midamble chips, or for IMB the number of chips in the TDM pilot region

C.2.3 Reference signal

The reference signal is constructed by the measuring equipment according to the relevant Tx specifications.

It is filtered by the same matched filter, mentioned in C.2.2, and stored at the intersymbol interference free instants. The following form represents the reference signal in the entire measurement interval:

one vector **R**, containing $N = n_s \times sf + m_a$ complex samples;

where ns, sf and ma have the same meaning as defined above in C.2.2.

C.2.4 Classification of measurement results

The measurement results achieved by the global in-channel Tx test can be classified into two types:

- **Results of type "deviation"**, where the error-free parameter has a non-zero magnitude. (These are the parameters that represent the signal). These parameters are:

RF Frequency

Power (in case of single code)

Code Domain Power (in case of multi-code)

Timing (only for UE) (see Note: Deviation)

(Additional parameters: see Note: Deviation)

- **Results of type "residual"**, where the error-free parameter has value zero. (These are the parameters that represent the error values of the measured signal; ideally, their magnitude is zero). These parameters are:

Error Vector Magnitude (EVM)

Peak Code Domain Error (PCDE)

(Additional parameters: see Note: Residual)

C.2.5 Process definition to achieve results of type "deviation"

The reference signal (**R**; see subclause C.2.3) and the signal under Test (**Z**; see subclause C.2.2) are varied with respect to the parameters mentioned in subclause C.2.4 under "results of type deviation" in order to achieve best fit. Best fit is achieved when the RMS difference value between the varied signal under test and the varied reference signal is an absolute minimum.

Overview:

$$FCT [Z(\tilde{f}, \tilde{t}, \tilde{\varphi}, g_1, g_2, \dots, g_{synch}) - R(f, t, \varphi, \tilde{g}_1, \tilde{g}_2, \dots, \tilde{g}_{synch})] = \textit{Minimum!}$$

Z: Signal under test.

R: Reference signal,

with frequency f , the timing t , the phase φ , gain of code1 (g_1), gain of code2 (g_2) etc, and the gain of the synch channel g_{synch}

The parameters marked with a tilde in **Z** and **R** are varied in order to achieve a best fit.

R' and **Z'** are each of length $ns * sf$ and depending on the length of the measurement interval result of possibly multiple successive applications of the minimum process.

Detailed formula: see Note: Formula for the minimum process

The varied reference signal, after the best-fit process, will be called **R'**.

The varied signal under test, after the best fit process, will be called **Z'**.

R' and **Z'** are each of length $ns * sf$ and depending on the length of the measurement interval result of possibly multiple successive applications of the minimum process.

Those parameter values, which - after the best-fit process -lead to **R'** and **Z'**, represent directly the wanted results of type "deviation". These parameter values are expressed as deviations from the reference value, using the same units as the corresponding reference value.

In the case of multi-code transmission, the best-fit process of the type "deviation" parameters frequency, timing (and any additional parameter as e.g. RF phase) is not done with respect to the individual codes, but commonly for the complete code set used; therefore, the process returns one measurement value only for each parameter.

(These parameters are not varied on the individual codes signals such that the process would return k_r frequency errors... . (k_r : number of codes in the reference signal)).

The only type-"deviation"-parameters varied individually are the code domain gain factors (g_1, g_2, \dots)

C.2.5.1 Decision Point Power

The mean-square value of the signal-under-test, sampled at the best estimate of the of Intersymbol-Interference-free points using the process defined in subclause 2.5, is referred to the *Decision Point Power* (DPP):

C.2.5.2 Code-Domain Power

The samples, Z' , are separated into symbol intervals to create n_s time-sequential vectors \mathbf{z} with sf complex samples comprising one symbol interval. The *Code Domain Power* is calculated according to the following steps:

- 1) Take the vectors \mathbf{z} defined above.
- 2) To achieve meaningful results it is necessary to descramble \mathbf{z} , leading to \mathbf{z}'
- 3) Take the orthogonal vectors of the channelization code set \mathbf{C} (all codes belonging to one spreading factor) as defined in TS 25.213 and TS 25.223 (range +1, -1), and normalize by the norm of the vectors to produce $\mathbf{C}_{norm} = \mathbf{C} / \text{sqrt}(sf)$. (see Note: Symbol length)
- 4) Calculate the inner product of \mathbf{z}' with \mathbf{C}_{norm} . Do this for all symbols of the measurement interval and for all codes in the code space.
This gives an array of format $k \times n_s$, each value representing a specific symbol and a specific code, which can be exploited in a variety of ways.

k : total number of codes in the code space

n_s : number of symbols in the measurement interval

- 5) Calculate k mean-square values, each mean-square value unifying n_s symbols within one code. (These values can be called "*Absolute CodeDomainPower* (CDP)" [Volt^2].) The sum of the k values of CDP is equal to DPP.
- 6) Normalize by the decision point power to obtain

$$\text{Relative CodeDomainPower} = \frac{\text{Absolute CodeDomainPower}}{\text{DecisionPointPower}}$$

C.2.6 Process definition to achieve results of type "residual"

The difference between the varied reference signal (\mathbf{R}' ; see subclause C.2.5.) and the varied Tx signal under test (\mathbf{Z} ; see subclause C.2.2) is the error vector \mathbf{E} versus time:

$$\mathbf{E} = \mathbf{Z}' - \mathbf{R}'.$$

Depending on the parameter to be evaluated, it is appropriate to represent \mathbf{E} in one of the following two different forms:

Form EVM (representing the physical error signal in the entire measurement interval)

One vector \mathbf{E} , containing $N = n_s \times sf + ma$ complex samples;

where n_s , sf and ma have the same meaning as defined above in C.2.2.

Form PCDE (derived from Form EVM by separating the samples into symbol intervals)

n_s time-sequential vectors \mathbf{e} with sf complex samples comprising one symbol interval.

E gives results of type "residual" applying the two algorithms defined in subclauses C.2.6.1 and C.2.6.2.

C.2.6.1 Error Vector Magnitude (EVM)

The Error Vector Magnitude EVM is calculated according to the following steps:

- 1) Take the error vector **E** defined in subclause C.2.6 (Form EVM) and calculate the RMS value of **E**; the result will be called RMS(**E**).
- 2) Take the varied reference vector **R** defined in subclause C.2.3 and calculate the RMS value of **R**; the result will be called RMS(**R**).
- 3) Calculate EVM according to:

$$\text{EVM} = \frac{\text{RMS}(\mathbf{E})}{\text{RMS}(\mathbf{R})} \times 100\% \text{ (here, EVM is relative and expressed in \%)}$$

(see Note: TDD)

(see Note: Formula for EVM)

C.2.6.2 Peak Code Domain Error (PCDE)

The Peak Code Domain Error is calculated according to the following steps:

- 1) Take the error vectors **e** defined in subclause C.2.6 (Form PCDE)
- 2) Take the orthogonal vectors of the spreading code set **C** (all codes belonging to one spreading factor) as defined in TS 25.213 and TS 25.223 (range +1, -1). (see Note: Symbol length) and normalize by the norm of the vectors to produce $\mathbf{C}_{\text{norm}} = \mathbf{C}/\text{sqrt}(\text{sf})$. (see Note: Symbol length)
- 3) To achieve meaningful results, it is necessary to descramble **e**, leading to **e'**
- 4) Calculate the inner product of **e'** with \mathbf{C}_{norm} . Do this for all symbols of the measurement interval and for all codes in the code space.
This gives an array of format $k \times n_s$, each value representing an error-vector representing a specific symbol and a specific code, which can be exploited in a variety of ways.
 - k: total number of codes in the code space
 - n_s : number of symbols in the measurement interval
- 5) Calculate k RMS values, each RMS value unifying n_s symbols within one code.
(These values can be called "Absolute CodeEVMs" [Volt].)
- 6) Find the peak value among the k "absolute Code-EVMs".
(This value can be called "Absolute PeakCodeEVM" [Volt].)
- 7) Calculate PCDE according to:

$$\text{PCDE} = 10 \lg \frac{(\text{absolute PeakCodeEVM})^2}{(\text{RMS}(\mathbf{R}))^2} \text{ dB} . \quad \text{(a relative value in dB)}$$

see Note: TDD

see Note: Synch channel

C.2.6.3 Relative Code Domain Error (RCDE)

The Relative Code Domain Error is calculated for a wanted code according to the following steps:

- 1) Calculate the value "*Absolute CodeEVM*" [Volt] for the wanted code according to C.2.6.2, as an RMS value unifying $n_s = 2400$ symbols corresponding to the measurement interval of one timeslot.
- 2) Calculate the value "*Absolute CodeDomainPower (CDP)*" [Volt²] for the wanted code according to C.2.5.2, with $n_s = 2400$ symbols corresponding to the measurement interval of one timeslot.
- 3) Calculate RCDE according to:

$$10 \cdot \lg \frac{(\text{"AbsoluteCodeEVM"})^2}{\text{"AbsoluteCodeDomainPower (CDP)"}} \text{dB}$$

- 4) The average RCDE across a set of wanted codes is defined as the mean of the linear RCDE values and subsequently expressed in dB.

C.3 Notes

C.3.1 Symbol length

A general code-multiplexed signal is multi-code and multi-rate. In order to avoid unnecessary complexity, the measurement applications use a unique symbol-length, corresponding to a specific spreading factor, regardless of the really intended spreading factor. Nevertheless, the complexity with a multi-code / multi-rate signal can be mastered by introducing appropriate definitions.

C.3.2 Deviation

It is conceivable to regard more parameters as type „deviation“, e.g. chip clock and RF phase. However, because chip clock and RF frequency are linked together by a statement in the core specifications [1], it is sufficient to process RF frequency only.

The parameter RF phase must be varied within the best-fit process (C.2.5). Although necessary, this parameter-variation does not describe any error, as the modulation schemes used in the system do not depend on an absolute RF-phase.

The parameter Timing must be varied within the best fit process (C.2.5.) This parameter variation does not describe any error, when applied to the Node B test. However when applied to the UE test, it describes the error of the UE's Timing Advance.

C.3.3 Residual

It is conceivable to regard more parameters as type „residual“, e.g. IQ origin offset. As it is not the intention of the test to separate for different error sources, but to quantify the quality of the signal, all such parameters are not extracted by the best-fit process, instead remain part of EVM and PCDE.

C.3.4 TDD

EVM covers the midamble (or for IMB the TDM pilot region) part as well as the data part; however PCDE disregards the midamble (or IMB TDM pilot) part.

C.3.5 Synch channel

A node B signal contains a physical synch channel, which is non-orthogonal, related to the other DPCHs. In this context note: The code channel bearing the result of PCDE is exactly one of the DPCHs (never the synch channel). The origin of PCDE (erroneous code power) can be any DPCH and/or the synch channel. This means that the error due to the synch channel is projected onto the other (orthogonal) codes that make up the code domain.

C.3.6 Formula for the minimum process

$$L(\Delta\tilde{f}, \Delta\tilde{t}, \Delta\tilde{\varphi}, \Delta\tilde{g}_c, \dots, \Delta\tilde{g}_{prim}, \Delta\tilde{g}_{seci}, \Delta\tilde{g}_{mid}) = \sum_{v=0}^{N-1} |Z(v) - R(v)|^2$$

where

L is the function to be minimised

The parameters to be varied in order to minimize are:

$\Delta\tilde{f}$ the RF frequency offset

$\Delta\tilde{t}$ the timing offset

$\Delta\tilde{\varphi}$ the phase offset

$\Delta\tilde{g}_c \dots$ code power offsets (one offset for each code)

$\Delta\tilde{g}_{mid}$ the power offset of the midamble (or for IMB the TDM pilot region)

$\Delta\tilde{g}_{prim}$ the code power offset of the primary SCH

$\Delta\tilde{g}_{seci}$ the code power offsets of secondary SCHs, (i: 1,2,3)

($\Delta\tilde{g}_{prim}$ and $\Delta\tilde{g}_{seci}$ are only applied, if the timeslot under test contains the synchronisation channel.)

$Z(v)$ Samples of the signal under Test

$R(v)$ Samples of the reference signal

$\sum_{v=0}^{N-1}$ counting index v starting at the beginning of the measurement interval and ending at its end.

N No of chips during the measurement interval.

$Z(v)$: Samples of the signal under Test. It is modelled as a sequence of complex baseband samples $Z(\gamma)$ with a time-shift Δt , a frequency offset Δf , a phase offset $\Delta\varphi$, the latter three with respect to the reference signal.

$$Z(v) = Z(v - \Delta\tilde{t}) * e^{-j2\pi\Delta\tilde{f}v} * e^{-j\Delta\tilde{\varphi}}$$

$R(v)$: Samples of the reference signal:

$$R(v) = \sum_{c=1}^{No. of codes} (g_c + \Delta\tilde{g}_c) * Chip_c(v) + (g_{prim} + \Delta\tilde{g}_{prim}) * Chip_{prim}(v) + (g_{seci} + \Delta\tilde{g}_{seci}) * Chip_{seci}(v) + (g_{mid} + \Delta\tilde{g}_{mid}) * Chip_{mid}(v)$$

where

g nominal gain of the code channel or midamble (or for IMB the TDM pilot region)

$\Delta\tilde{g}$ The gain offset to be varied in the minimum process

$Chip(v)$ is the chip sequence of the code channel or midamble (or for IMB the TDM pilot region)

Indices at g, Δg and Chip: The index indicates the code channel:

c = 1,2,... No of code channels

prim = primary SCH

seci = three secondary SCHs, i:1,2,3

Range for Chip_c: +1,-1

C.3.7 Formula for EVM

$$EVM = \sqrt{\frac{\sum_{\nu=0}^{N-1} |Z'(\gamma) - R'(\gamma)|^2}{\sum_{\nu=0}^{N-1} |R'(\gamma)|^2}} * 100\%$$

Z'(γ), R'(γ) are the varied measured and reference signals.

Annex D (informative): Derivation of Test Requirements

The Test Requirements in this specification have been calculated by relaxing the Minimum Requirements of the core specification using the Test Tolerances defined in subclause 5.11. When the Test Tolerance is zero, the Test Requirement will be the same as the Minimum Requirement. When the Test Tolerance is non-zero, the Test Requirements will differ from the Minimum Requirements, and the formula used for this relaxation is given in tables D.1 to D.3

Note that a formula for applying Test Tolerances is provided for all tests, even those with a test tolerance of zero. This is necessary in the case that the Test System uncertainty is greater than that allowed in subclause 5.10. In this event, the excess error shall be subtracted from the defined test tolerance in order to generate the correct tightened Test Requirements as defined in subclause 5.12.

For example, a Test System having 0,9 dB accuracy for test 6.2 Maximum output power (which is 0,2 dB above the limit specified in subclause 5.10.2) would subtract 0,2 dB from the Test Tolerance of 0,7 dB defined in subclause 5.11.1. This new test tolerance of 0,5 dB would then be applied to the Minimum Requirement using the formula defined in Table D.1 to give a new range of ±2,5 dB of the manufacturer's rated output power.

For the case where an excess error of 0.2 dB exists, when applied to a test with a test tolerance of zero, the test tolerance used in the formula would be -0.2 dB.

Table D.1: Derivation of Test Requirements (Transmitter tests)

Test	Minimum Requirement in TS 25.105 (numbering of tables in the column below refers to TS 25.142)	Test Tolerance (TT)	Test Requirement in TS 25.142
6.2 Maximum output power	In normal conditions ... within +2 dB and -2 dB of the manufacturer's rated output power In extreme conditions... within +2,5 dB and -2,5 dB of the manufacturer's rated output power	0,7 dB	Formula: Upper limit + TT Lower limit - TT In normal conditions ... within +2,7 dB and -2,7 dB of the manufacturer's rated output power In extreme conditions... within +3,2 dB and -3,2 dB of the manufacturer's rated output power
6.3 Frequency stability	Frequency stability Wide Area BS: $\pm 0,05$ ppm Local Area BS: $\pm 0,1$ ppm	12 Hz	Formula: \pm (frequency stability + TT) Wide Area BS: $\pm (0,05 \text{ ppm} + 12 \text{ Hz})$ Local Area BS: $\pm (0,1 \text{ ppm} + 12 \text{ Hz})$
6.4.2 Power control steps	single step: step size tolerance specified in table 6.3 ten steps: minimum and maximum average rate of change in mean power specified in table 6.3	single step: 0,1 dB ten steps: 0,3 dB	Formula: single step: \pm (step size tolerance + TT) ten steps: maximum average rate + TT minimum average rate - TT 0,1 dB and 0,3 dB, respectively, applied as above to table 6.3
6.4.3 Power control dynamic range	range ≥ 30 dB	0,3 dB	Formula: Range - TT range $\geq 29,7$ dB
6.4.4 Minimum output power	PRAT - 30 dB	0,7 dB	Formula : PRAT - 30 dB + TT PRAT - 29,3 dB
6.4.5 Primary CCPCH power	PCCPCH power tolerance defined in table 6.8	0,8 dB	Formula: \pm (power tolerance + TT) 0,8 dB applied as above to table 6.8
6.4.6 Differential accuracy of Primary CCPCH power	Differential accuracy of PCCPCH power: $\leq \pm 0,5$ dB	0,1 dB	Formula: \pm (PCCPCH tolerance + TT) $\pm 0,6$ dB
6.5.1 Transmit OFF power	Tx OFF power limit < -79 dBm	2,0 dB	Formula: < Tx OFF power limit + TT < - 77 dBm

6.5.2 Transmit ON/OFF time mask	<p>Tx power limit:</p> <p>3,84 Mcps TDD option: < -33 dBm or -79 dBm, resp.</p> <p>1,28 Mcps TDD option: < -42 dBm or -82 dBm, resp.</p>	<p>< -33 dBm: 0,7 dB < -79 dBm: 2,0 dB</p> <p>< -42 dBm: 0,7 dB < -82 dBm: 2,0 dB</p>	<p>Formula: < Tx power limit + TT</p> <p>for 3,84 Mcps TDD option: < -32,3 dBm or < - 77 dBm</p> <p>for 1,28 Mcps TDD option: < -41,3 dBm or < -80 dBm</p>
6.6.1 Occupied bandwidth	<p>occupied bandwidth limit</p> <p>3,84 Mcps TDD option: = 5 MHz 1,28 Mcps TDD option: 1,6 MHz</p>	0 kHz	<p>Formula: Occupied bandwidth limit + TT</p> <p>3,84 Mcps TDD option: = 5 MHz 1,28 Mcps TDD option: 1,6 MHz</p>
6.6.2.1 Spectrum emission mask	<p>Maximum level defined in tables 6.13 to 6.16</p>	1,5 dB	<p>Formula: Maximum level + TT</p> <p>Add 1,5 dB to Maximum level entries in tables 6.13 to 6.16</p>

<p>6.6.2.2 Adjacent Channel Leakage power Ratio (ACLR)</p>	<p><u>3.84 Mcps TDD option:</u></p> <p>minimum requirement: ACLR limit = 45 dB at 5 MHz ACLR limit = 55 dB at 10 MHz</p> <p>requirement for operation in the same geographic area with unsynchronised TDD BS or FDD BS on adjacent channels: Maximum Level defined in tables 6.23 and 6.23AA</p> <p>requirement in case of co-siting with unsynchronised TDD BS or FDD BS operating on adjacent channels: Maximum Level defined in tables 6.24 and 6.24A</p> <p><u>1.28 Mcps TDD option:</u></p> <p>minimum requirement: ACLR limit = 40 dB at 1,6 MHz ACLR limit = 45 dB at 3,2 MHz</p> <p>requirement for operation in the same geographic area with unsynchronised TDD or FDD on adjacent channels: Maximum Level defined in tables 6.23A, 6.23B and 6.23C</p> <p>requirement in case of co-siting with unsynchronised TDD or FDD on an adjacent channel: Maximum Level defined in tables 6.24B, 6.24C and 6.24D</p>	<p><u>3,84 Mcps TDD option:</u> min. req. : 0,8 dB</p> <p>operation in the same geographic area: 4 dB (TBD in table 6.23A, 5 MHz offset, resp.) for Wide Area BS ; 0,8 dB for Local Area BS</p> <p>co-siting: TBD for Wide Area BS; 1 dB for Local Area BS</p> <p><u>1,28 Mcps TDD option:</u> min. req. : 0,8 dB</p> <p>operation in the same geographic area: 1 dB or 4 dB for the Wide Area BS; 0,8 dB for the Local Area BS</p> <p>co-siting: TBD for the Wide Area BS; 1 dB for the Local Area BS</p>	<p>Formula: ACLR limit - TT</p> <p><u>3,84 Mcps TDD option:</u> min. requirement: ACLR limit = 44,2 dB at 5 MHz ACLR limit = 54,2 dB at 10 MHz</p> <p>operation in the same geographic area: Wide Area BS: Add 4 dB (TBD in table 6.23A, 5 MHz offset, resp.) to the Maximum Level entries in tables 6.23 and 6.23AA. Local Area BS: Add 0,8 dB to the Maximum Level entries in tables 6.23 and 6.23AA. co-siting: Wide Area BS: Add TBD to the Maximum Level entries in tables 6.24 and 6.24A. Local Area BS: Add 1 dB to the Maximum Level entries in tables 6.24 and 6.24A.</p> <p><u>1,28 Mcps TDD option:</u> min. requirement: ACLR limit = 39,2 dB at 1,6 MHz ACLR limit = 44,2 dB at 3,2 MHz</p> <p>operation in the same geographic area: Wide Area BS: Add 1 dB to the Maximum Level entries in tables 6.23A and 6.23B, and 4 dB to the Maximum Level entry in table 6.23C. Local Area BS: Add 0,8 dB to the Maximum Level entries in tables 6.23A, 6.23B and 6.23C. co-siting: Wide Area BS: Add TBD to the Maximum Level entries in tables 6.24B, 6.24C and 6.24D. Local Area BS: Add 1 dB to the Maximum Level entries in tables 6.24B, 6.24C and 6.24D.</p>
<p>6.6.3 Spurious emissions</p>	<p>maximum level defined in tables 6.29 to 6.37</p>	<p>0 dB</p>	<p>Formula: Maximum limit + TT</p> <p>add 0 dB to maximum levels in tables 6.29 to 6.37</p>

<p>6.7 Transmit intermodulation (interferer requirements)</p> <p>This tolerance applies to the stimulus and not the measurements defined in 6.6.2.1, 6.6.2.2 and 6.6.3.</p>	<p>Wanted signal level - interferer level = 30 dB</p>	<p>0 dB</p>	<p>Formula: Ratio + TT</p> <p>Wanted signal level - interferer level = 30 + 0 dB</p>
<p>6.8.1 Modulation accuracy</p>	<p>EVM limit = 12,5 %</p>	<p>0 %</p>	<p>Formula: EVM limit + TT</p> <p>EVM limit = 12,5 %</p>
<p>6.8.2 Peak code domain error</p>	<p>PCDE limit = - 28 dB</p>	<p>1 dB</p>	<p>Formula: PCDE limit + TT</p> <p>PCDE limit = - 27 dB</p>
<p>6.8.3 Relative Code Domain Error</p>	<p>RCDE limit = -21.9 dB</p>	<p>1.0 dB</p>	<p>Formula: RCDE limit + TT</p> <p>RCDE limit = -20.9 dB</p>
<p>6.8.4 Time alignment error in MIMO transmission</p>	<p>1,28 Mcps TDD option: Max time alignment error = 65 ns Min time alignment error = - 65 ns</p>	<p>1,28 Mcps TDD option: [78] ns</p>	<p>Formula: Max time alignment error + TT Min time alignment error – TT</p> <p>1,28 Mcps TDD option: Max time alignment error = [143]ns Min time alignment error = [-143]ns</p>

Table D.2: Derivation of Test Requirements (Receiver tests)

Test	Minimum Requirement in TS 25.105 (numbering of tables in the column below refers to TS 25.142)	Test Tolerance (TT)	Test Requirement in TS 25.142
7.2 Reference sensitivity	<p>Reference sensitivity level 3,84 Mcps TDD option: = Wide Area BS: -109 dBm Local Area BS: -95 dBm</p> <p>1,28 Mcps TDD option: Wide Area BS: -110 dBm Local Area BS: -96 dBm</p> <p>BER limit = 0,001</p>	0,7 dB	<p>Formula: Reference sensitivity level + TT</p> <p>Reference sensitivity level 3,84 Mcps TDD option: Wide Area BS: -108,3 dBm Local Area BS: -94,3 dBm</p> <p>1,28 Mcps TDD option: Wide Area BS: -110dBm Local Area BS: -95,3 dBm</p> <p>BER limit is not changed</p>
7.3 Dynamic range	<p>Wanted signal level = <REFSENS> + 30 dB</p> <p>Interfering AWGN level 3,84 Mcps TDD option: Wide Area BS: -73 dBm/3,84 MHz Local Area BS: -59 dBm/3,84 MHz</p> <p>1,28 Mcps TDD option: Wide Area BS: -76 dBm/1,28 MHz Local Area BS: -62 dBm/1,28 MHz</p>	1,2 dB	<p>Formula: Wanted signal level + TT AWGN level unchanged</p> <p>Wanted signal level = <REFSENS> + 31,2 dB</p>
7.4 Adjacent Channel Selectivity (ACS)	<p>Wanted signal level = Ref. sensitivity level + 6 dB</p> <p>Interfering signal level 3,84 Mcps TDD option: Wide Area BS: -52 dBm/3,84 MHz Local Area BS: -38 dBm/3,84 MHz</p> <p>1,28 Mcps TDD option: Wide Area BS: -55 dBm/1,28 MHz Local Area BS: -41 dBm/1,28 MHz</p>	0 dB	<p>Formula: Wanted signal level + TT Interfering signal level unchanged</p> <p>Wanted signal level = Ref. sensitivity level + 6 dB</p>
7.5 Blocking characteristics	<p>Wanted signal level = <REFSENS> + 6 dB</p> <p>3,84 Mcps TDD option: Interfering signal level see tables 7.6 to 7.10</p> <p>1,28 Mcps TDD option: Interfering signal level see tables 7.6A to 7.10A</p>	0 dB	<p>Formula: Wanted signal level + TT Interfering signal level unchanged</p> <p>Wanted signal level = <REFSENS> + 6 dB</p>
7.6 Intermodulation characteristics	<p>Wanted signal level = <REFSENS> + 6 dB</p> <p>Interferer1 level (10 MHz offset CW for 3,84 Mcps TDD option; 3,2 MHz offset CW for 1,28 Mcps TDD option)) = -48 dBm</p> <p>Interferer2 level (20 MHz offset W- CDMA Modulated for 3,84 Mcps TDD option; 6,4 Mcps offset W- CDMA Modulated for 1,28 Mcps TDD option)) = -48 dBm</p>	0 dB	<p>Formula: Wanted signal level + TT</p> <p>Interferer 1 level: unchanged Interferer 2 level: unchanged</p> <p>Wanted signal level = <REFSENS> + 6 dB</p>

7.7	Spurious emissions	Maximum level defined in table 7.12	0 dB	Formula: Maximum level + TT Add TT to maximum level in table 7.12
-----	--------------------	-------------------------------------	------	--

Table D.3: Derivation of Test Requirements (Performance requirements)

Test	Minimum Requirement in TS 25.105	Test Tolerance (TT)	Test Requirement in TS 25.142
8.2 Demodulation in static propagation conditions		TBD	
8.3 Demodulation of DCH in multipath fading conditions		TBD	
8.3A Demodulation of DCH in high speed train conditions	Received $\frac{\hat{I}_{or}}{I_{oc}}$ value	0.4dB	Minimum requirement + TT

Annex E (informative): Acceptable uncertainty of Test Equipment

This informative annex specifies the critical parameters of the components of an overall Test System (e.g. Signal generators, Signal Analysers etc.) which are necessary when assembling a Test System which complies with subclause 5.10 Acceptable Uncertainty of Test System. These Test Equipment parameters are fundamental to the accuracy of the overall Test System and are unlikely to be improved upon through System Calibration.

Table E.1: Equipment accuracy for transmitter measurements

Test	Equipment accuracy	Range over which equipment accuracy applies
6.2 Maximum output power	Not critical	Not critical
6.3 Frequency stability	± 10 Hz + timebase = 12 Hz	Measurements in the range ± 500 Hz.
6.4.2 Power control steps	single step: $\pm 0,1$ dB ten steps: $\pm 0,3$ dB	P_{max} to $P_{max} - 30$ dB
6.4.3 Power control dynamic range	$\pm 0,3$ dB	P_{max} to $P_{max} - 30$ dB
6.4.4 Minimum output power	Not critical	P_{max} to $P_{max} - 30$ dB
6.4.5 Primary CCPCH power	Not critical	Not critical
6.4.6 Differential accuracy of Primary CCPCH power	$\pm 0,1$ dB	
6.5.1 Transmit OFF power	Not critical	Not critical
6.5.2 Transmit ON/OFF time mask	Not critical	Not critical
6.6.1 Occupied bandwidth	± 100 kHz	± 1 MHz of the minimum requirement
6.6.2.1 Spectrum emission mask	Not critical	Not critical
6.6.2.2 ACLR	minimum requirement: $\pm 0,8$ dB requirement in case of operation in proximity: $\pm 4,0$ dB requirement in case of co-siting: TBD	Measurements in the range ± 3 dB of the minimum requirement at signal power = P_{max}
6.6.3 Spurious emissions	Not critical	Not critical
6.7 Transmit intermodulation (interferer requirements)	Not critical	Not critical
6.8.1 Modulation accuracy	$\pm 2,5$ % (for single code)	Specified accuracy applies to measurement results between $\pm 7,5$ % and $17,5$ % at signal power = P_{max} to $P_{max} - 30$ dB
6.8.2 Peak code domain error	± 1 dB	Measurements in the range -25 dB to -30 dB at signal power = P_{max}
6.8.3 Relative Code Domain Error	$\pm 1,0$ dB	Measurements in the range $-18,9$ to $-24,9$ dB at signal power = P_{max}
6.8.4 Time alignment error in MIMO transmission	1,28 Mcps TDD option: $\pm [78]$ ns	

Table E.2: Equipment accuracy for receiver measurements

Subclause	Equipment accuracy	Range over which equipment accuracy applies
7.2 Reference sensitivity level	Not critical	Not critical
7.3 Dynamic range	Not critical	Not critical
7.4 Adjacent channel selectivity	Not critical	Not critical
7.5 Blocking characteristics	Not critical	Not critical
7.6 Intermodulation characteristics	Not critical	Not critical
7.7 Spurious Emissions	Not critical	Not critical

Table E.3: Equipment accuracy for performance measurements

Subclause	Equipment accuracy	Range over which equipment accuracy applies
8.2 Demodulation in static propagation conditions	Not critical	Not critical
8.3 Demodulation of DCH in multipath fading conditions	Not critical	Not critical
8.3A Demodulation of DCH in high speed train conditions	Not critical	Not critical

Annex F (normative): General rules for statistical testing

F.1 Statistical testing of receiver BER/BLER performance

F.1.1 Error Definition

Bit Error Ratio (BER) and Block Error Ratio (BLER) are defined in section 3.1.

F.1.2 Test Method

Each test is performed in the following manner:

- a) Setup the required test conditions.
- b) Record the number of samples tested and the number of occurred events (bit error or block error)
- c) Stop the test at a stop criterion which is minimum test time or an early pass or an early fail event.
- d) Once the test is stopped decide according to the pass fail decision rules (subclause F.1.7)

F.1.3 Test Criteria

The test shall fulfil the following requirements:

- a) good pass fail decision
 - 1) to keep reasonably low the probability (risk) of passing a bad unit for each individual test;
 - 2) to have high probability of passing a good unit for each individual test;
- b) good balance between test time and statistical significance
 - 3) to perform measurements with a high degree of statistical significance;
 - 4) to keep the test time as low as possible.

F.1.4 Calculation assumptions

F.1.4.1 Statistical independence

- a) It is assumed, that error events are rare ($\lim_{BER, BLER} \rightarrow 0$) independent statistical events. However the memory of the convolutional/turbo coder is terminated after oneTTI. Samples and errors are summed up everyTTI. So the assumption of independent error events is justified.
- b) In the BLER test with fading there is the memory of the multipath fading channel which interferes the statistical independence. A minimum test time is introduced to average fluctuations of the multipath fading channel. So the assumption of independent error events is justified approximately.

F.1.4.2 Applied formulas

The formulas, applied to describe the BER BLER test, are based on the following experiments:

- 1) After having observed a certain number of errors (**ne**) the number of samples are counted to calculate BER BLER. Provisions are made (note 1) such that the complementary experiment is valid as well:

2) After a certain number of samples (**ns**) the number of errors, occurred, are counted to calculate BER BLER.

Experiment 1) stipulates to use the following Chi Square Distribution with degree of freedom ne :

$$2 * dchisq(2 * NE, 2 * ne).$$

Experiment 2) stipulates to use the Poisson Distribution:

$$dpois(ne, NE)$$

(NE: mean of the distribution)

To determine the early stop conditions, the following inverse cumulative operation is applied:

$0.5 * qchisq(D, 2 * ne)$. This is applicable for experiment (1) and (2).

D: wrong decision risk per test step

Note: other inverse cumulative operations are available, however only this is suited for experiment (1) and (2).

F.1.4.3 Approximation of the distribution

The test procedure is as follows:

During a running measurement for a BS ns (number of samples) and ne (number of errors) are accumulated and from this the preliminary BER BLER is calculated. Then new samples up to the next error are taken. The entire past and the new samples are basis for the next preliminary BER BLER. Depending on the result at every step, the BS can pass, can fail or must continue the test.

As early pass- and early fail-BSs leave the statistical totality under consideration, the experimental conditions are changed every step resulting in a distribution that is truncated more and more towards the end of the entire test. Such a distribution can not any more be handled analytically. The unchanged distribution is used as an approximation to calculate the early fail and early pass bounds.

F.1.5 Definition of good pass fail decision

This is defined by the probability of wrong decision F at the end of the test. The probability of a correct decision is $1-F$.

The probability (risk) to fail a good DUT shall be $\leq F$ according to the following definition: The failed DUT is still better than the specified error ratio (Test requirement) with a probability of $\leq F$.

The probability to pass a bad DUT shall be $\leq F$ according to the following definition: The passed DUT is still worse than M times the specified error ratio ($M > 1$ is the bad DUT factor) with a probability of $\leq F$.

This definitions lead to an early pass and an early fail limit:

Early fail: $ber \geq berlim_{fail}$

$$berlim_{fail}(D, ne) = \frac{2 * ne}{qchisq(D, 2 * ne)} \quad (1)$$

For $ne \geq 7$

Early pass: $ber \leq berlim_{bad_{pass}}$

$$berlim_{bad_{pass}}(D, ne) = \frac{2 * ne * M}{qchisq(1 - D, 2 * ne)} \quad (2)$$

For $ne \geq 1$

With

ber (normalized BER,BLER): BER,BLER according to F.1.1 divided by Test requirement

D: wrong decision probability for a test step . This is a numerically evaluated fraction of F, the wrong decision probability at the end of the test. See table F.1.

ne: Number of error events

M: bad DUT factor see table F.1.

qchisq: inverse-cumulative-function of the chi-squared-distribution

F.1.6 Good balance between test time and statistical significance

Three independent test parameters are introduced into the test and shown in Table F.1. These are the obvious basis of test time and statistical significance. From the first two of them four dependent test parameters are derived. The third independent test parameter is justified separately.

Table F.1: independent and dependant test parameters

Independent parameters			Dependant parameters		
Test Parameter	Value	Reference	Test parameter	Value	Reference
Bad DUT factor M	1.5	Tables F.4 & F.5	Early pass/fail condition	Curves	Subclause F.1.5 Figure F.1
Final probability of wrong pass/fail decision F	0.2%, (0.02%, note 2)	Subclause F.1.5	Target number of error events	345	Table F.4 & F.5
			Probability of wrong pass/fail decision per test step D	0.0085%, (0.0008% and 0.008%, note 2)	
			Test limit factor TL	1.234	Table F.4 & F.5
Minimum test time		Tables F.2 & F.3			

The minimum test time is derived from the following justification:

- 1) For no propagation conditions and static propagation condition

No early fail calculated from fractional number of errors <1 (see note 1)

- 2) For multipath fading condition

No stop of the test until [990] wavelengths are crossed during relevant BS reception timeslots, relevant for BER BLER testing, with the speed given in the fading profile.

- 3) For high speed train condition

Scenario 1: 82.3s. This corresponds to 4 complete cycles of approach towards and departure leave to and from a BS antenna

Scenario 3: 28.8s. This corresponds to 4 complete cycles of approach towards and departure from a BS antenna

Table F.2: minimum Test time

Fading profile	Minimum test time
Multipath propagation 3 km/h	[164 s* TSPF/TSRX]
Multipath propagation 120 km/h	[4.1 s* TSPF/TSRX]
High speed train conditions Scenario 1	82.3 sec
High speed train conditions Scenario 3	28.8 sec

TSPF = Time slots per frame
 TSRX = relevant reception timeslots per frame, relevant for the BER BLER test

TSPF and TSRX form the prolongation factor and depend on the user data rate and the TDD Option (3,84 Mchip/s or 1,28 Mchip/s)

Table F.3: Prolongation factor for minimum Test time

User Data rate	TSPF/TSRX for TDD 3,84 Mchip/s	TSPF/TSRX for TDD 1,28 Mchip/s
12.2 kbit/s	15/1	7/1
64 kbit/s	15/1	7/1
144 kbit/s	15/1	7/2
384 kbit/s	15/3	7/4

In tables F.4 and F.5 the minimum test time is converted in minimum number of samples.

F.1.7 Pass fail decision rules

No decision is allowed before the minimum test time is elapsed.

- 1) If minimum Test time < time for target number of error events then the following applies: The required confidence level 1-F (= correct decision probability) shall be achieved. This is fulfilled at an early pass or early fail event.

For BER:

For every TTI (Transmit Time Interval) sum up the number of bits (ns) and the number of errors (ne) from the beginning of the test and calculate

BER_1 (including the artificial error at the beginning of the test (Note 1)) and

BER_0 (excluding the artificial error at the beginning of the test (Note 1)).

If BER_0 is above the early fail limit, fail the DUT.

If BER_1 is below the early pass limit, pass the DUT.

Otherwise continue the test

For BLER:

For every TTI sum up the number of blocks (ns) and the number of erroneous blocks (ne) from the beginning of the test and calculate

$BLER_1$ (including the artificial error at the beginning of the test (Note 1)) and

$BLER_0$ (excluding the artificial error at the beginning of the test (Note 1)).

If $BLER_1$ is below the early pass limit, pass the DUT.

If $BLER_0$ is above the early fail limit, fail the DUT.

Otherwise continue the test

- 2) If the minimum test time \geq time for target error events, then the test runs for the minimum test time and the decision is done by comparing the result with the test limit.

For BER:

For every TTI (Transmit Time Interval) sum up the number of bits (ns) and the number of errors (ne) from the beginning of the test and calculate BER_0

For BLER:

For every TTI sum up the number of blocks (ns) and the number of erroneous blocks (ne) from the beginning of the test and calculate BLER₀

If BER₀/BLER₀ is above the test limit, fail the DUT.

If BER₀/BLER₀ is on or below the test limit, pass the DUT.

F.1.8 Test conditions for BER,BLER Tests

Table F.4: Test conditions for BER tests

Type of test (BER)	Propagation conditions	Test requirement (BER)	Test limit (BER)= Test requirement (BER)x TL TL	Target number of error events (time) Note *	Minimum number of samples	Prob that good unit will fail = Prob that bad unit will pass (%)	Bad unit BER factor M
Reference Sensitivity Level	-	0.001	1.234	345 (22.9s)	Note 1	0.2	1.5
Dynamic Range	-	0.001	1.234	345 (22.9s)	Note 1	0.2	1.5
Adjacent Channel Selectivity	-	0.001	1.234	345 (22.9s)	Note 1	0.2	1.5
Blocking Characteristics Pass condition Note 2	-	0.001	1.251	402 (26.3s)	Note 1	0.2	1.5
Blocking Characteristics Fail condition Note 2	-	0.001	1.251	402 (26.3s)	Note 1	0.02	1.5
Intermodulation Characteristics	-	0.001	1.234	345 (22.9s)	Note 1	0.2	1.5

Note *: the time in the bracket means the reception time

Table F.5: Test conditions for BLER tests

Type of test (BLER)	Information Bit rate (kbit/s)	Test requirement (BLER)	Test limit (BLER)= Test requirement (BLER)x TL TL	Target number of error events (time)	Minimum number of samples (time) TDD 3,84 Mchip/s	Minimum number of samples (time) TDD 1,28 Mchip/s	Prob that bad unit will pass = Prob that good unit will fail (%)	Bad unit BLER factor M
Demodulation in Static Propagation conditions	12.2	0.01	1.234	345 (559s)	Note1	Note1	0.2	1.5
	64	0.1		(55.9s)				
		0.01		(55.9s)				
	144	0.1		(55.9s)				
		0.01		(55.9s)				
	384	0.1	(28s)					
		0.01	(280s)					
Demodulation of DCH in Multi-path Fading Propagation conditions 3km/h (Case 1, Case 2)	12.2	0.01	1.234	345 (559s)	[(2460s)]	[(1148s)]	0.2	1.5
	64	0.1		(55.9s)	[123000]	[5740]		
		0.01		(55.9s)	[123000]	[5740]		
	144	0.1		(55.9s)	[123000]	[5740]		
		0.01		(55.9s)	[123000]	[5740]		
	384	0.1	(28s)	[(820s)]	[(278s)]			
		0.01	(280s)	[82000]	[27800]			
		0.01	(280s)	[82000]	[27800]			
Demodulation of DCH in Multi-path Fading Propagation conditions 120 km/h (Case3)	12.2	0.01	1.234	345 (559s)	[(61.5s)]	[(28.7s)]	0.2	1.5
	64	0.1		(55.9s)	[3075]	[1435]		
		0.01		(55.9s)	[3075]	[1435]		
	144	0.1		(55.9s)	[3075]	[1435]		
		0.01		(55.9s)	[3075]	[1435]		
	384	0.1	(28s)	[(20.5s)]	[(7.175s)]			
		0.01	(280s)	[2050]	[718]			
		0.01	(280s)	[2050]	[718]			
Demodulation of DCH in high speed train condition	12.2	0.01	1.234	345 (559s)		Scenario 1 (82.3s)	0.2	1.5
	64	0.1		(55.9s)		4115		
		0.01		(55.9s)		Scenario 3 (28.8s)		
						1440		

F.1.9 Practical Use (informative)

See figure F.1:

- The early fail limit represents formula (1) in F.1.5. The range of validity is $n_e \geq 7$ (≥ 8 in case of blocking test) to $n_e = 345$
- The early pass limit represents formula (2) in F.1.5. The range of validity is $n_e = 1$ to $n_e = 345$. See note 1
- The intersection co-ordinates of both curves are : target number of errors $n_e = 345$ and test limit $TL = 1.234$.
- The range of validity for TL is $n_e > 345$.

A typical BER BLER test, calculated from the number of samples and errors (F.1.2.(b)) using experimental method (1) or (2) (see F.1.4.2 calculation assumptions) runs along the yellow trajectory. With an errorless sample the trajectory goes down vertically. With an erroneous sample it jumps up right. The tester checks if the BER BLER test intersects the early fail or early pass limits. The real time processing can be reduced by the following actions:

$BLER_0$ (excluding the artificial error at the beginning of the test (Note 1)). is calculated only in case of an error event.

BER₀ (excluding the artificial error at the beginning of the test (Note 1)). is calculated only in case of an error event within a TTI.

So the early fail limit cannot be missed by errorless samples.

The check against the early pass limit may be done by transforming formula (2) in F.1.5 such that the tester checks against a Limit-Number-of-samples (NL(ne)) depending on the current number of errors (including the artificial error at the beginning of the test (Note 1)).

Early pass if

$$NL(ne) \geq \frac{qchisq(1 - D, 2 * ne)}{2 * TR * M}$$

TR: test requirement (0.001)

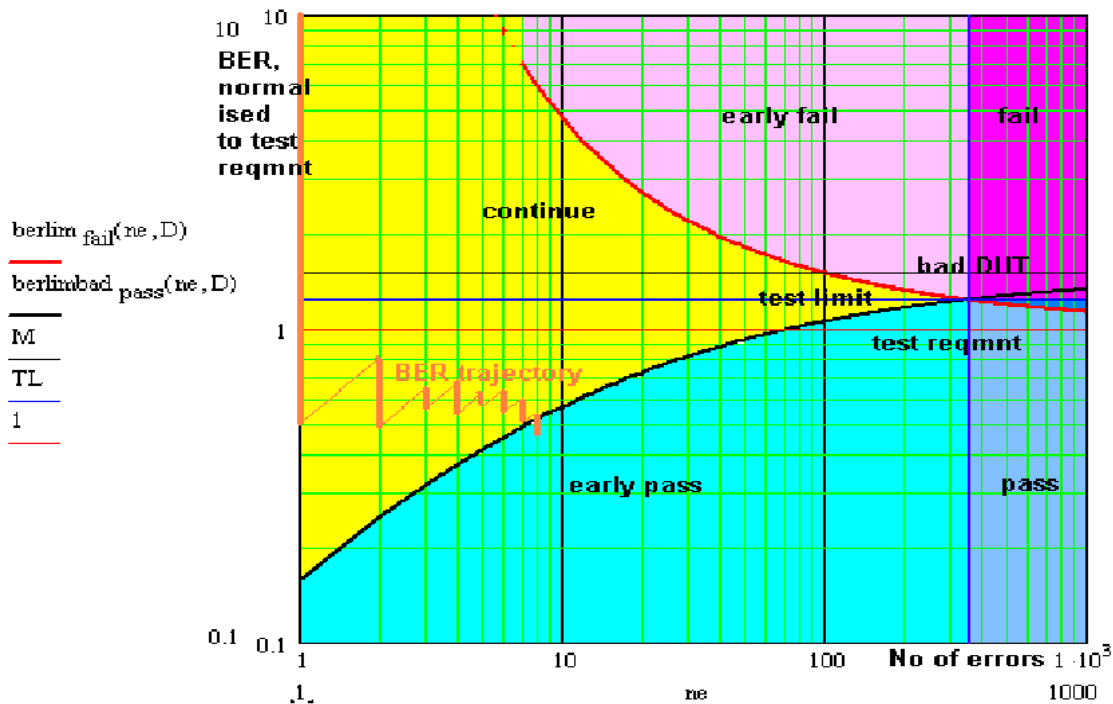

Figure F.1

NOTE 1: At the beginning of the test, an artificial error is introduced. This ensures that an ideal DUT meets the valid range of the early pass limit. In addition this ensures that the complementary experiment (F.1.4.2 bullet point (2)) is applicable as well.

For the check against the early fail limit the artificial erroneous sample, introduced at the beginning of the test, is disregarded.

Due to the nature of the test, namely discrete error events, the early fail condition shall not be valid, when fractional errors <1 are used to calculate the early fail limit: Any early fail decision is postponed until number of errors ne ≥ 7. In the blocking test any early fail decision is postponed until number of errors ne ≥ 8.

NOTE 2: F=0.2% is intended to be used for a test containing a few BER/BLER tests (e.g. receiver sensitivity is repeated 12 times(3 RF Channels * 2 Power-supplies * 2 Temperatures). For a test containing many BER/BLER tests (e.g. blocking test) this value is not appropriate for a single BER/BLER test.

The blocking test contains approx. 12750 single BER tests. A DUT on the limit will fail approx. 25 to 26 times due to statistical reasons using wrong decision probability at the end of the test $F=0.2\%$. This shall be solved by the following rule:

All passes (based on $F=0.2\%$) are accepted, including the wrong decisions due to statistical reasons.

An early fail limit based on $F=0.02\%$ instead of 0.2% is established. That ensures that wrong decisions due to statistical reasons are reduced to 2 to 3 in 12750 BER measurements. If the fail cases are ≤ 12 , it is allowed to repeat each fail cases 1 time before the final verdict.

These asymmetric test conditions ensure that a DUT on the limit consumes hardly more test time for a blocking test than in the symmetric case and reduces the wrong decision probability considerably and on the other hand the repetition allowance sufficiently suppresses the residual statistically caused wrong verdict for the aggregate test.

Annex G (informative): Change History

Table G.1: Change History

TSG	Doc	CR	R	Title	Cat	Curr	New	Work Item
RP-29				Rel-7 version created based on v6.3.0			7.0.0	
RP-29	RP-050579	0176		Introduction of UMTS 2.6 GHz operating band for TDD	B	6.2.0	7.0.0	RInImp-UMTS2600 TDD
RP-29	RP-050579	0177		UMTS 2.6 GHz TDD Propagation Conditions	B	6.2.0	7.0.0	RInImp-UMTS2600 TDD
RP-29	RP-050579	0178	2	Channel Raster for 3,84 Mcps TDD in UMTS 2.6 GHz	B	6.2.0	7.0.0	RInImp-UMTS2600 TDD
RP-29	RP-050579	0179		UMTS 2.6 GHz TDD BS Transmitter Specifications	B	6.2.0	7.0.0	RInImp-UMTS2600 TDD
RP-29	RP-050579	0180		UMTS 2.6 GHz TDD BS Receiver Specifications	B	6.2.0	7.0.0	RInImp-UMTS2600 TDD
RP-29	RP-050579	0181		Introduction of Propagation Conditions for UMTS 2.6 GHz for 1,28Mcps TDD	B	6.2.0	7.0.0	RInImp-UMTS2600 TDD
RP-29	RP-050579	0182		UMTS 2.6 GHz TDD BS receiver spurious emission	B	6.2.0	7.0.0	RInImp-UMTS2600 TDD
RP-30	RP-050740	0183		Introduction of UMTS 2.6 BS transmitter specification for 1,28Mcps TDD	B	7.0.0	7.1.0	RInImp-UMTS2600 TDD
RP-30	RP-050740	0184		Introduction of UMTS 2.6 BS receiver specification for 1,28Mcps TDD	B	7.0.0	7.1.0	RInImp-UMTS2600 TDD
RP-30	RP-050841	0186		Name correction of logical and transport channels in Annex 2	A	7.0.0	7.1.0	TEI6
RP-32	RP-060307	0187		UMTS 2.6 GHz blocking and spurious emission test condition	F	7.1.0	7.2.0	RInImp-UMTS2600 TDD
RP-32	RP-060312	0188	1	7.68 Mcps Frequency Band & Channel Arrangement	B	7.1.0	7.2.0	VHCRTDD-RF
RP-32	RP-060312	0189		7.68 Mcps Transmitter Characteristics	B	7.1.0	7.2.0	VHCRTDD-RF
RP-32	RP-060312	0190	1	7.68 Mcps Receiver Characteristics	B	7.1.0	7.2.0	VHCRTDD-RF
RP-32	RP-060312	0191		7.68 Mcps - Channel Performance	B	7.1.0	7.2.0	VHCRTDD-RF
RP-32	RP-060312	0192		7.68 Mcps Measurement Channels & Propagation Conditions	B	7.1.0	7.2.0	VHCRTDD-RF
RP-33	RP-060517	0205		Clarification of Tx spurious emission level from 3,84 Mcps and 7.68 Mcps TDD BS into PHS band	F	7.2.0	7.3.0	TEI7
RP-33	RP-060518	0212	1	Clarification on the deployment of UTRA TDD in Japan	A	7.2.0	7.3.0	TEI
RP-33	RP-060519	0214	1	Tx and Rx Spurious Emission from 3,84 Mcps and 7.68 Mcps TDD BS into FDD bands in Japan	A	7.2.0	7.3.0	TEI6
RP-33	RP-060528	0206		Performance requirements for 3,84 Mcps E-DCH channel.	B	7.2.0	7.3.0	EDCHTDD-RF
RP-33	RP-060526	0207	2	7.68 Mcps Operations in 2.6 GHz band	B	7.2.0	7.3.0	RInImp-UMTS26V HCR TDD
RP-34	RP-060818	0215		Performance requirements for 7.68 Mcps E-DCH channel.	B	7.3.0	7.4.0	TEI7
RP-35	RP-070081	0219		HS-SICH detection performance test specification for 1.28Mcps TDD	A	7.4.0	7.5.0	TEI6

RP-35	RP-070082	0216		Tx and Rx Spurious Emission from 7.68 Mcps TDD BS into FDD band in Japan	F	7.4.0	7.5.0	TEI7
RP-35	RP-070082	0217		Clarification on the deployment of UTRA TDD in Japan	F	7.4.0	7.5.0	TEI7
RP-36	RP-070369	0225		Modifying category B spurious emission limits for UTRA TDD BS	A	7.5.0	7.6.0	TEI
RP-36	RP-070377	0221		Adding test case of E-DCH performance requirement for 1.28Mcps TDD option	F	7.5.0	7.6.0	LCRTDD-EDCH-RF
RP-37	RP-070651	0227		7.68 Mcps TDD Option test tolerances and transmit ON/OFF time mask level.	F	7.6.0	7.7.0	TEI7
RP-37	RP-070651	0226		Inclusion of 7.68 Mcps in the scope of document	F	7.6.0	7.7.0	TEI7
RP-39	RP-080119	0229	1	Correcting the power allocation for HS-SICH performance detection	A	7.7.0	7.8.0	TEI6
RP-40	RP-080329	0234		RCDE for 1.28Mcps TDD 64QAM modulated codes	B	7.8.0	7.9.0	RANimp-64Qam1.28 TDD
RP-40	RP-080384	0233	1	UMTS2300MHz propagation channel model addition for 1.28Mcps TDD in 25.142	B	7.9.0	8.0.0	RInImp8-UMTS2300 TDD
RP-40	RP-080384	0232	1	UMTS2300MHz Receiver performance addition for 1.28Mcps TDD in 25.142	B	7.9.0	8.0.0	RInImp8-UMTS2300 TDD
RP-40	RP-080384	0231	1	UMTS2300MHz Transmitter performance addition for 1.28Mcps TDD in 25.142	B	7.9.0	8.0.0	RInImp8-UMTS2300 TDD
RP-40	RP-080384	0230	1	UMTS2300MHz New band introduction for 1.28Mcps TDD in 25.142	B	7.9.0	8.0.0	RInImp8-UMTS2300 TDD
RP-41	RP-080636	0236	1	Modify the Fixed Reference Channels of E-DCH for LCR TDD	A	8.0.0	8.1.0	TEI7
RP-43	RP-090166	0241		Correction of BS reference measurement channel and performance requirement for LCR TDD 384kbps service	A	8.1.0	8.2.0	TEI4
RP-43	RP-090197	0242		Introduction of band 1880MHz for 25.142	F	8.1.0	8.2.0	RInImp9-UMTS1880 TDD
RP-43	RP-090197	0243		UMTS1880MHz: transmitter characteristic	F	8.1.0	8.2.0	RInImp9-UMTS1880 TDD
RP-43	RP-090197	0244		UMTS1880MHz: receiver characteristic and propagation conditions	F	8.1.0	8.2.0	RInImp9-UMTS1880 TDD
RP-44	RP-090553	0247		Correction of local area base station coexistence requirements	F	8.2.0	8.3.0	RInImp9-UMTS1880 TDD
RP-44	RP-090554	0245	1	Addition of Time alignment error test for BS supporting 1.28Mcps TDD MIMO	F	8.2.0	8.3.0	RANimp-LCRMIMO
RP-44	RP-090556	0246		Correction on the test parameter table of E-DCH for 1.28Mcps TDD	F	8.2.0	8.3.0	TEI8
RP-45	RP-090818	251		Changes to 25.142 accommodating IMB	F	8.3.0	8.4.0	MBSFN-DOB
RP-46	RP-091285	255		BS test requirements in high speed train condition for LCR TDD	B	8.5.0	9.0.0	RInImp9-LCRTDD350
RP-47	RP-100257	260		Correction of E-DCH FRC3 for LCR TDD	A	9.0.0	9.1.0	TEI7
RP-47	RP-100253	262		Protection of E-UTRA for UTRA TDD BS	A	9.0.0	9.1.0	LTE-RF
RP-47	RP-100273	257		Additional BS test requirements in high speed train conditions for LCR TDD	F	9.0.0	9.1.0	RInImp9-LCRTDD350
RP-48	RP-100631	263	1	Corrections for performance requirements in HST condition	F	9.1.0	9.2.0	TEI9
RP-49	RP-100922	264	1	Clarification on applicability of requirements for multi-carrier BS	F	9.2.0	9.3.0	RInImp9-RFmulti
RP-50	RP-101340	275		Addition of test case for HS-SICH type2 performance	A	9.3.0	9.4.0	TEI8
RP-50	RP-101340	277		Clarifications of Base Station transmit and receive configurations	A	9.3.0	9.4.0	TEI8
RP-50	RP-101351	267	1	Introduction of the BS requirements for 1.28Mcps TDD MC-HSUPA	B	9.4.0	10.0.0	TDD_MC_H SUPA
RP-50	RP-101352	269		1.28Mcps TDD Home NodeB class into Base Station class in 25.142	B	9.4.0	10.0.0	HNB_LCRT DD_RF-Perf

RP-50	RP-101352	270		1.28Mcps TDD Home NodeB Transmitter	B	9.4.0	10.0.0	HNB_LC RT_DD_RF-Perf
RP-50	RP-101352	271		1.28Mcps TDD Home NodeB Receiver	B	9.4.0	10.0.0	HNB_LC RT_DD_RF-Perf
RP-50	RP-101352	272		1.28Mcps TDD Home NodeB Demodulation Requirement	B	9.4.0	10.0.0	HNB_LC RT_DD_RF-Perf
RP-51	RP-110352	0278	-	Adding missing demodulation requirements for LCR TDD Home BS	F	10.0.0	10.1.0	TE110
RP-51	RP-110352	0279	1	Harmonization of co-existence/co-location requirements between 25.142 and 36.141	F	10.0.0	10.1.0	TE110
RP-52	RP-110796	280		Correction of co-existence requirement for UTRA TDD	F	10.1.0	10.2.0	TE110
RP-52	RP-110796	281		Correction of the test port description for TS 25.142	F	10.1.0	10.2.0	TE110
RP-53	RP-111262	282		Clarification of demodulation in static propagation and Multipath fading case 1 for Home BS	F	10.2.0	10.3.0	TE110
RP-56	RP-120783	286		Update to regional requirement table	F	10.3.0	10.4.0	TE110
RP-56	RP-120765	292	1	Additional spurious emissions requirements for PHS	A	10.3.0	10.4.0	TE18
RP-56	RP-120795	283	1	TDD blocking for co-location	F	10.4.0	11.0.0	TE111
RP-56	RP-120795	284	1	WA co-existence/co-location	F	10.4.0	11.0.0	TE111
RP-56	RP-120795	285	1	Co-existence between TDD systems	F	10.4.0	11.0.0	TE111
RP-56	RP-120795	287		LA co-existence/co-location	F	10.4.0	11.0.0	TE111
RP-56	RP-120795	288		Co-existence/co-location between LA TDD systems	F	10.4.0	11.0.0	TE111
RP-56	RP-120793	289		Introduction of Band 44	B	10.4.0	11.0.0	LTE_APAC7 00-Core
RP-57	RP-121296	296		Clarification for TDD Band	A	11.0.0	11.1.0	TE18
RP-59	RP-130287	297		Update of BS co-existence requirement towards UTRA TDD bands in China	F	11.1.0	11.2.0	TE111
RP-60	RP-130768	298	1	On additional ACLR requirement	F	11.2.0	11.3.0	TE111
RP-60	RP-130764	299		Co-existence around 3500 MHz	F	11.2.0	11.3.0	RInImp8- UMTS LTE3 500
RP-60	RP-130768	300		Rel.11 CR for 25.142: Editorial Corrections and Amendment with Missed TT Values	F	11.2.0	11.3.0	TE111
RP-60	RP-130768	301	1	Addition of MC-HSDPA for general clause 6.1	F	11.2.0	11.3.0	TE111