

3GPP TR 24.826 V11.0.0 (2011-06)

Technical Report

3rd Generation Partnership Project; Technical Specification Group Core Network and Terminals; Study on impacts on signalling between User Equipment (UE) and core network from energy saving (Release 11)



Keywords

LTE, network, signalling, energy saving

3GPP

Postal address

3GPP support office address

650 Route des Lucioles - Sophia Antipolis
Valbonne - FRANCE
Tel.: +33 4 92 94 42 00 Fax: +33 4 93 65 47 16

Internet

<http://www.3gpp.org>

Copyright Notification

No part may be reproduced except as authorized by written permission.
The copyright and the foregoing restriction extend to reproduction in all media.

© 2011, 3GPP Organizational Partners (ARIB, ATIS, CCSA, ETSI, TTA, TTC).
All rights reserved.

UMTS™ is a Trade Mark of ETSI registered for the benefit of its members
3GPP™ is a Trade Mark of ETSI registered for the benefit of its Members and of the 3GPP Organizational Partners
LTE™ is a Trade Mark of ETSI registered for the benefit of its Members and of the 3GPP Organizational Partners
GSM® and the GSM logo are registered and owned by the GSM Association

Contents

1	Scope	6
2	References.....	7
3	Definitions, symbols and abbreviations	8
3.1	Definitions	8
3.2	Abbreviations	8
4	Overview.....	9
5	Analysis of signalling procedures between the UE and core network for energy saving scenarios	11
5.1	Switch-off/on of 3GPP macro cells	11
5.1.1	General description	11
5.1.2	Overlaid intra-RAT	11
5.1.3	Non-overlaid intra-RAT	11
5.1.4	Inter-RAT	12
5.1.5	Key issue: Registration signalling resulting from switch-off/on of macro cells	12
5.1.5.1	Overlaid intra-RAT case (E-UTRAN)	12
5.1.5.2	Inter-RAT case (E-UTRAN target for switch-off).....	14
5.1.6	Key issue: Cross layer aspects.....	14
5.1.7	Key issue: Idle mode UEs with emergency bearer services	15
5.1.8	Key issue: Impact of inter-RAT energy saving on signalling over SGs	15
5.2	Switch-off/on of 3GPP home cells	16
5.2.1	General description	16
5.2.2	Key issue: Incidental synchronization of H(e)NB switch-off/s switch-on.....	16
5.3	Switch-off/on of WLAN access networks in 3GPP I-WLAN	16
5.3.1	General description	16
5.3.2	Key issue: Latency associated with WLAN access network re-selection after switch-off (WLAN 3GPP IP access).....	17
5.3.3	Key issue: Mass effect resulting from WLAN access network re-selection after switch-off.....	17
5.4	Switch-off/on of non-3GPP access networks	18
5.4.1	General description	18
5.4.2	Key issue: Degradation of service due to switch-off of non-3GPP access networks.....	18
5.5	Power adaptation for 3GPP macro cells	19
5.5.1	General description	19
5.5.2	Key issue: Coverage boundaries.....	20
5.6	Common issues.....	21
5.6.1	Key issue: Increased ANDSF load	21
5.6.2	Key issue: Signalling overload for multi-access and flow mobility.....	22
5.7	Additional analysis	22
5.7.1	Potential interaction between machine type communication and energy saving	22
6	Potential optimizations and enhancements in procedures.....	24
6.1	Solution "Optimized configuration of tracking areas and TAI lists".....	24
6.1.1	Description	24
6.1.2	Benefits	24
6.1.3	Limitations	24
6.1.4	Impacts on 3GPP Specifications.....	24
6.2	Solution "Adding time dependence to configuration settings in MOs"	24
6.2.1	Description	24
6.2.2	Benefits	25
6.2.3	Limitations	25
6.2.4	Impacts on 3GPP Specifications.....	26
6.3	Solution "Dynamic radio access network sharing"	26
6.3.1	Description	26
6.3.2	Benefits	26
6.3.3	Limitations	27
6.3.4	Impacts on 3GPP Specifications.....	27
6.4	Solution "Network based handling for multi-access and flow mobility"	27

6.4.1	Description	27
6.4.2	Benefits	28
6.4.3	Limitations	28
6.4.4	Impacts on 3GPP Specifications.....	28
6.5	Solution "Activation times in ANDSF data"	29
6.5.1	Description	29
6.5.1.1	Variant 1	29
6.5.1.2	Variant 2	29
6.5.2	Benefits	29
6.5.3	Limitations	29
6.5.4	Impacts on 3GPP Specifications.....	30
7	Conclusions	31
7.1	General overview of key issues and solutions.....	31
7.2	Detailed conclusions.....	31
Annex A (informative):	Change history.....	33

Foreword

This Technical Report has been produced by the 3rd Generation Partnership Project (3GPP).

The contents of the present document are subject to continuing work within the TSG and may change following formal TSG approval. Should the TSG modify the contents of the present document, it will be re-released by the TSG with an identifying change of release date and an increase in version number as follows:

Version x.y.z

where:

- x the first digit:
 - 1 presented to TSG for information;
 - 2 presented to TSG for approval;
 - 3 or greater indicates TSG approved document under change control.
- y the second digit is incremented for all changes of substance, i.e. technical enhancements, corrections, updates, etc.
- z the third digit is incremented when editorial only changes have been incorporated in the document.

1 Scope

The present document contains the result of the study on the impacts on signalling between the UE and core network when energy saving measures are applied to network entities.

The study aims, within the defined CT1 work areas, at:

- analysing UE idle mode procedures and signalling between the UE and core network resulting from switch on/off of radio equipment in all types of 3GPP accesses, including home cell deployment and I-WLAN, as well as power adaptation of radio equipment (where applicable);
- performing a corresponding analysis for connected mode UEs;
- analysing similar impacts from activation status of non-3GPP access networks;
- documenting limitations, weaknesses and inefficiencies in these procedures, with emphasis on mass effects in the signalling between the UE and core network; and
- studying potential optimizations and enhancements to these procedures.

The study also evaluates potential enhancements to 3GPP specifications under CT1 responsibility.

This study takes into account decisions made by other 3GPP working groups in their related work.

2 References

The following documents contain provisions which, through reference in this text, constitute provisions of the present document.

- References are either specific (identified by date of publication, edition number, version number, etc.) or non-specific.
- For a specific reference, subsequent revisions do not apply.
- For a non-specific reference, the latest version applies. In the case of a reference to a 3GPP document (including a GSM document), a non-specific reference implicitly refers to the latest version of that document *in the same Release as the present document*.

- [1] 3GPP TR 21.905: "Vocabulary for 3GPP Specifications".
- [2] 3GPP TR 32.826: "Study on Energy Savings Management (ESM)".
- [3] 3GPP TS 23.234: "3GPP system to Wireless Local Area Network (WLAN) interworking; System description".
- [4] 3GPP TS 24.234: "3GPP System to Wireless Local Area Network (WLAN) interworking; WLAN User Equipment (WLAN UE) to network protocols".
- [5] 3GPP TS 33.234: "3G security; Wireless Local Area Network (WLAN) interworking security".
- [6] 3GPP TS 32.551: "Energy Saving Management (ESM); Concepts and requirements".
- [7] 3GPP TS 24.302: "Access to the 3GPP Evolved Packet Core (EPC) via non-3GPP access networks".
- [8] 3GPP TR 23.888: "System Improvements for Machine-Type Communications".
- [9] 3GPP TS 29.118: "Mobility Management Entity (MME) – Visitor Location Register (VLR) SGs interface specification".
- [10] 3GPP TS 24.167: "3GPP IMS Management Object (MO); Stage 3".
- [11] 3GPP TS 24.216: "Communication Continuity Management Object".
- [12] 3GPP TS 24.301: "Non-Access-Stratum (NAS) protocol for Evolved Packet System (EPS)".
- [13] 3GPP TS 24.237: "IP Multimedia Subsystem (IMS) Service Continuity; Stage 3".
- [14] 3GPP TS 23.251: "Network Sharing; Architecture and functional description".
- [15] 3GPP TS 23.401: "GPRS enhancements for E-UTRAN access".
- [16] 3GPP TS 23.402: "Architecture enhancements for non-3GPP accesses".
- [17] 3GPP TS 23.261: "IP flow mobility and seamless Wireless Local Area Network (WLAN) offload; Stage 2".
- [18] 3GPP TS 24.303: "Mobility management based on Dual-Stack Mobile IPv6; Stage 3".
- [19] 3GPP TR 36.927: "Evolved Universal Terrestrial Radio Access (E-UTRA); Potential solutions for energy saving for E-UTRAN".
- [20] 3GPP TS 24.368: "Non-Access Stratum (NAS) configuration Management Object (MO)".
- [21] 3GPP TS 24.008: "Mobile radio interface Layer 3 specification; Core network protocols; Stage 3".

3 Definitions, symbols and abbreviations

3.1 Definitions

For the purposes of the present document, the terms and definitions given in 3GPP TR 21.905 [1] and the following apply. A term defined in the present document takes precedence over the definition of the same term, if any, in 3GPP TR 21.905 [1].

Macro cell: generic term used for all cell types under operator's control (in contrast to "home cells" or "femto cells"); in this sense it includes also so-called "micro" and "pico" cells (used in the context of hierarchical cell structures).

3.2 Abbreviations

For the purposes of the present document, the abbreviations given in 3GPP TR 21.905 [1] and the following apply. An abbreviation defined in the present document takes precedence over the definition of the same abbreviation, if any, in 3GPP TR 21.905 [1].

4 Overview

One main energy saving mechanism in the context of this Technical Report is realized by switch-off of radio equipment on the network side. As a consequence, a UE currently being served by the radio equipment subject to switch-off will have to find an alternative, either in the same RAT (if possible by coverage, this would naturally be preferred), or in another RAT. We call these cases "intra-RAT energy saving" and "inter-RAT energy saving", respectively. The fundamental assumption is that, due to overlapping radio coverages, in all practically relevant cases an alternative radio access can indeed be found.

In figure 4-1 two base coverage scenarios allowing energy saving by switch-off are illustrated (only one representative UE shown).

On the left hand side an overlay structure of one and the same RAT is shown; apart from capacity considerations every UE in coverage area 2 can also be served by the radio equipment in coverage area 1; thus radio equipment for coverage area 2 may be switched off (during suitable times) for energy saving purposes. This is an intra-RAT energy saving case. A variant for the non-overlaid intra-RAT configuration is described in subclause 5.1.3 and subclause 5.5.

On the right hand side, in contrast, coverage area 4 is not fully overlaid by coverage area 3, and they belong to different RATs. Consequently, radio equipment for coverage area 4 could only be switched off if still other coverage areas exist (not shown, but indicated by dots), or all UEs are located in the overlapping area. This case realizes inter-RAT energy saving.

More details on such energy saving scenarios are found in 3GPP TR 32.826 [2] and 3GPP TR 36.927 [19].

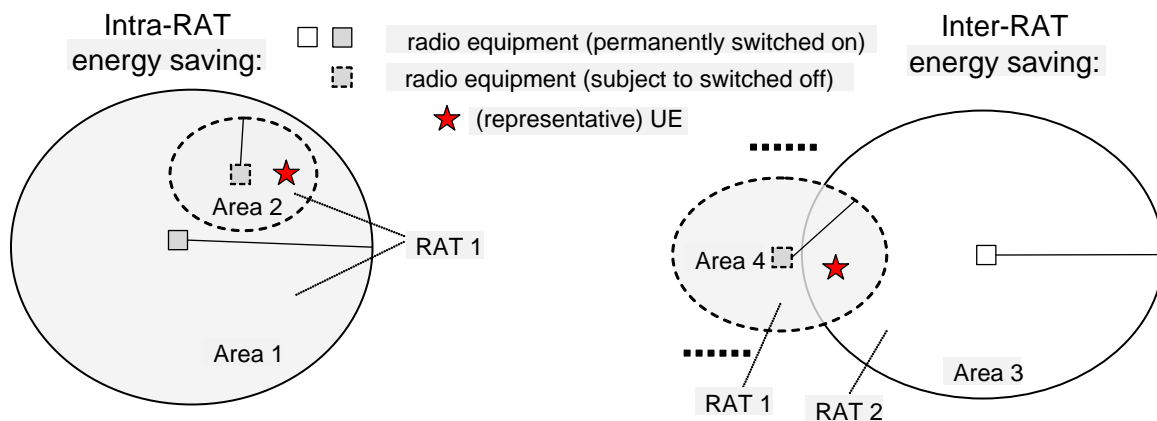

Figure 4-1: Two base coverage scenarios for energy saving by switch-off of radio equipment

In table 4-1 we use the terms "source radio" and "target radio" with the intended meaning that the considered UE transitions from on to the other radio access due to switch-off; we list all combinations in a matrix, for a UE attached for PS services. Regarding the UE behaviour following a loss of (source) radio access, depending on the availability of RATs as target radio access, we find either fully standardized and optimized behaviour within 3GPP RATs (GERAN, UTRAN, E-UTRAN), or non- or only partially standardized and optimized behaviour (if either source or target radio access is not a 3GPP access).

Table 4-1: Combinations of source and target radio for energy saving (for UE attached for PS services) and possible procedures after switch-off of source radio

		target radio →				
		GERAN	UTRAN	E-UTRAN	Non-3GPP access	I-WLAN
source radio ↓	GERAN	Idle mode: cell reselection + (potentially) LR Active mode: HO + (potentially) LR			(non-optimized) HO (on IP layer)	detach + AAA + tunnel setup
	UTRAN					
	E-UTRAN	(non-optimized) HO (on IP layer)				
	Non-3GPP access	(AAA cleanup + tunnel tear down) + attach / AAA + tunnel setup				
	I-WLAN					

NOTE: GERAN and UTRAN are assumed to be connected to the EPC supporting E-UTRAN and non-3GPP access.

The main diagonal of this matrix describes intra-RAT energy saving, and the non-diagonal elements constitute inter-RAT energy saving. A characteristic difference between the two directions of switching, i.e. between switching off and switching on an access network, is that with the latter the UE in case of non-optimized handover is not immediately forced to act, because it ends up in having more choices for access networks than before.

CS only mode encompasses solely GERAN and UTRAN radio access; however, RAN3 has defined enhancements for intra-RAT energy saving only for E-UTRAN. Aspects of CS/PS mode of operation are discussed in subclauses 5.1.8 and to some extent in subclause 5.1.6. Aspects of domain selection and relationship to applications are discussed in subclause 5.1.6.

5 Analysis of signalling procedures between the UE and core network for energy saving scenarios

5.1 Switch-off/on of 3GPP macro cells

5.1.1 General description

The following main characteristics of 3GPP RATs GERAN, UTRAN and E-UTRAN need to be taken into account in the study of energy saving:

- clear definition of idle and active mode;
- definition of registration areas (LAs, RAs, TAs);
- fully optimized handovers; and
- fully (operator) planned deployment.

General descriptions and more technical details are found in other sources (e.g. 3GPP TR 32.826 [2] and specifically for E-UTRAN in 3GPP TR 36.927 [19]). Here the goal is to complete the enumeration of cases and also consider more the aspects relevant to this study (i.e. signalling between the UE and core network).

5.1.2 Overlaid intra-RAT

A capacity enhancing cell, subject to switch-off for energy saving, is placed into the (full) coverage realized by other cells (see figure 5.1.2-1). Such a cell can be either totally within the range of one cell or it can intersect with multiple cells of the base coverage. The relative position of a capacity-enhancing cell, regarding registration area boundaries, determines whether signalling between the UE and core network is to be expected as a result of switching the cell off/on.

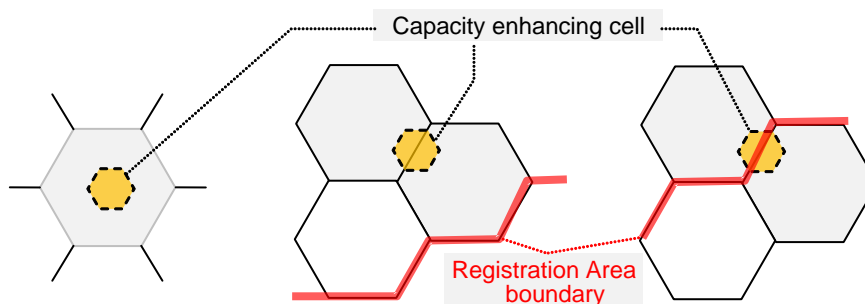

NOTE: In 3GPP TR 36.927 [19] this is called "inter-eNB scenario 1"

Figure 5.1.2-1: Coverage and registration areas for overlaid intra-RAT energy saving with 3GPP macro cells

5.1.3 Non-overlaid intra-RAT

The cell that is subject to switch-off has no alternative coverage, thus some cell adaption has to take place, in order not to disrupt service for the UEs due to a coverage "hole" of this RAT (and e.g. with no capability for an alternative RAT). As shown in figure 5.1.3-1, registration area boundaries will be distorted with switch-off.

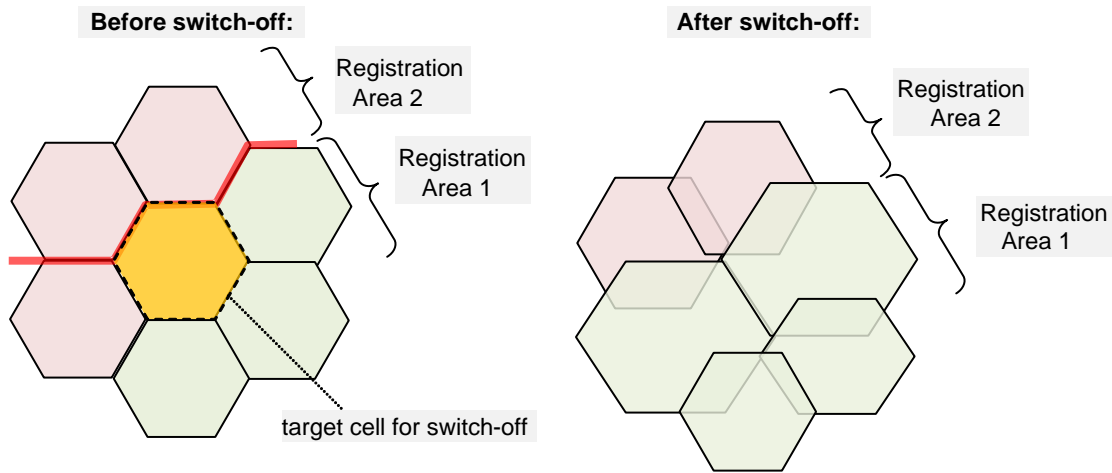

NOTE: In 3GPP TR 36.927 [19] this is called "inter-eNB scenario 2"

Figure 5.1.3-1: Coverage and registration areas for non-overlaid intra-RAT energy saving with 3GPP macro cells

5.1.4 Inter-RAT

This case is illustrated in figure 5.1.4-1.

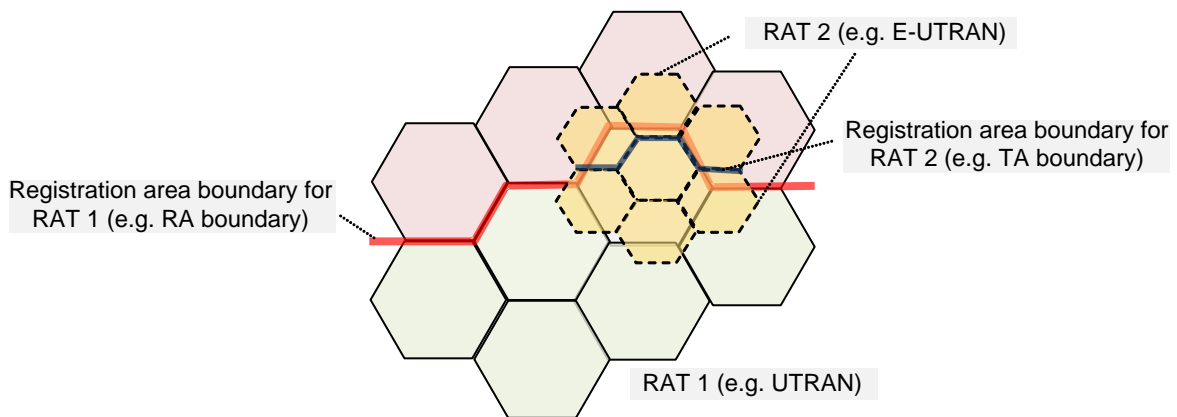

Figure 5.1.4-1: Coverage and registration areas for inter-RAT energy saving with 3GPP macro cells

5.1.5 Key issue: Registration signalling resulting from switch-off/on of macro cells

5.1.5.1 Overlaid intra-RAT case (E-UTRAN)

The situation is shown in figure 5.1.5-1 derived from the use case given in the annex B of 3GPP TS 32.551 [6] (it can be similarly applied to the other 3GPP RATs). Only idle mode UEs are considered here, as UEs in connected mode can be handled by the network via timely handovers to cells remaining permanently active.

Cell 5 is used for providing the peak capacity and is overlaid on cells 1 to 4 (it is called here a "capacity enhancing cell"). Incidentally, also a tracking area (TA) boundary is passing through, and cell 5 is (arbitrarily) allocated to TA1.

NOTE 1: The assumption that a capacity enhancing cell is never located on the border of a TA cannot be made, as it would be too restrictive.

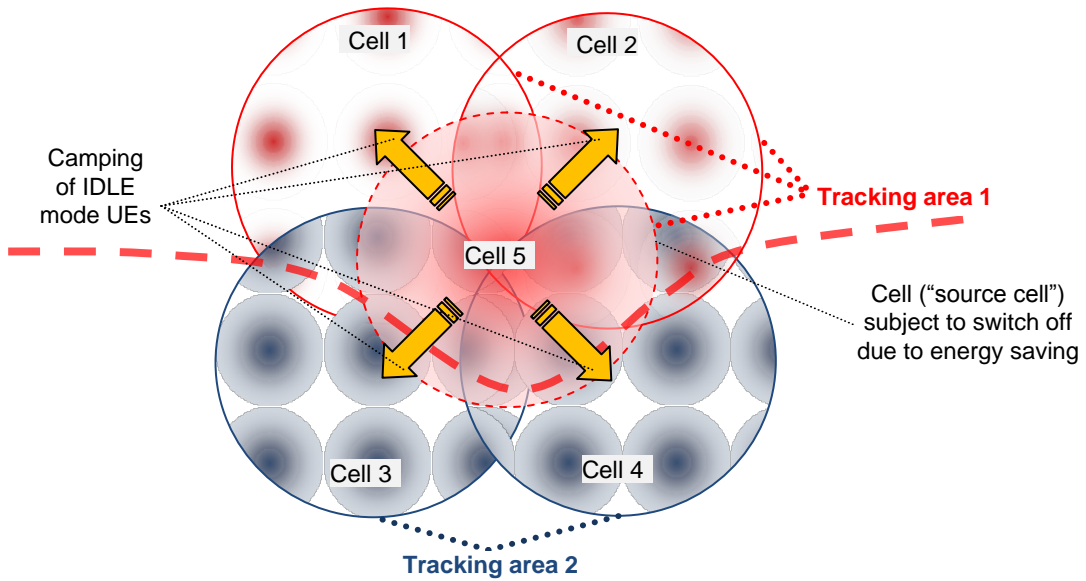

Figure 5.1.5-1: Capacity enhancing cell being switched off (overlaid intra-RAT case)

When switching off cell 5, all UEs camping on it have to re-select other cells. For those within coverage of cells 1 and 2 the cell re-selection affects only the UE internal state. In contrast, UEs within coverage of cells 3 and 4, after selecting these for camping, the corresponding UEs have to perform a TAU. In total, depending on the number of cells being switched off (nearly) at the same time and the actual TA configuration, there is a danger of overload on MME(s).

The situation after switch-on of a previously switched off capacity enhancing cell is shown in figure 5.1.5-2. The re-selection of cells occurs only gradually, due to the fact that some threshold in the difference of radio levels must be measured.

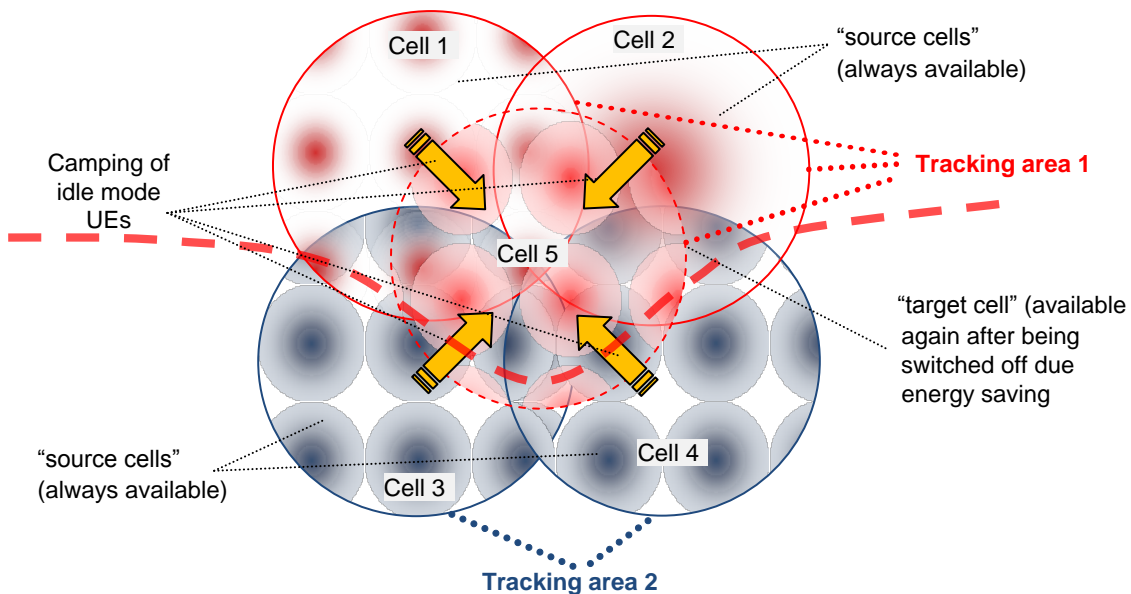

Figure 5.1.5-2: Example of a capacity enhancing cell being switched on again

A problem or at least an inefficiency can occur, if many UEs in idle mode start with their transmission of data (by issuing service requests) still in the source cells; this could have the effect that many handovers (into the target cell) are necessary. Depending on the TA configuration, additionally TAUs could be necessary (before the active mode is entered). The scenario is likely e.g. in the morning, when formerly sleeping users are waking up and start checking their mails, browsing internet in a synchronized manner, e.g. just before or after their favourite morning news broadcast. It would be advantageous if idle mode UEs re-select target cells more quickly after they have been switched on, before they become active.

NOTE 2: A switch-off can also be performed by a decrease of power over time. This case is described in subclause 5.5 "Power adaptation for 3GPP macro cells".

5.1.5.2 Inter-RAT case (E-UTRAN target for switch-off)

For this subclause it is assumed that GERAN/UTRAN provides the overall coverage and is used as fallback after E-UTRAN has been switched off.

At this time a similar issue as described in subclause 5.1.5.1 arises more massively (independent of a cell location on a registration area boundary), because all idle mode UEs with ISR not activated have to perform RAU signalling, after selection of GERAN/UTRAN.

UEs in idle mode with ISR activated benefit from the double registration. After selecting GERAN/UTRAN no immediate registration signalling is necessary. Their behavior regarding ISR deactivation timer is specified in 3GPP TS 24.301 [12] (subclause 5.1.3) and shown in figure 5.1.5.2-1.

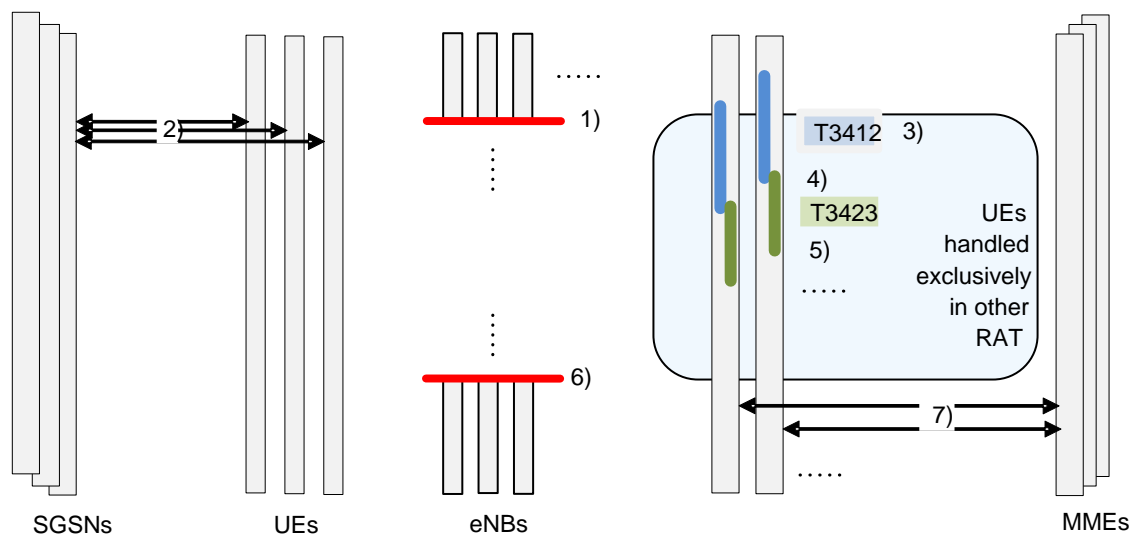

Figure 5.1.5.2-1: Behaviour of UEs with ISR activated when E-UTRAN is switched off

- 1) E-UTRAN is switched off for energy saving. UEs will subsequently fall into state EMM-REGISTERED.NO-CELL-AVAILABLE.
- 2) Affected UEs (those in the coverage area and currently registered with E-UTRAN), with ISR deactivated, have to perform RAU signalling, after selecting GERAN/UTRAN. This can lead to a massive peak in signalling, depending on synchronization of switch-off of eNBs (corresponding to the number of UEs affected).
- 3) Affected UEs with ISR activated have their periodic TAU timer running (unsynchronized, and in general with varying, individual durations). Only those are considered in the subsequent steps.
- 4) After expiry of the periodic TAU timer, affected UEs cannot perform the periodic TAU and start their individual timer for deactivation of ISR (T3423).
- 5) T3423 timers expire and UEs deactivate ISR.
- 6) E-UTRAN is switched on again.
- 7) UEs realize that E-UTRAN is again available and can re-select it. At this point they need to initiate TAU, which potentially leads to the re-activation of ISR.

5.1.6 Key issue: Cross layer aspects

In the current 3GPP system various control features exist which govern the selection of domains for delivery of services (e.g. voice, SMS). As an example, it may be an operator's preference to handle voice communication via IMS/PS only; if no HSPA is rolled out then effectively only E-UTRAN would remain for voice. This constitutes a cross layer

coupling (IMS voice layer effectively requires a particular radio access), and there are related administrative settings (per UE) in NAS related specifications. The situation is illustrated for one UE in figure 5.1.6-1.

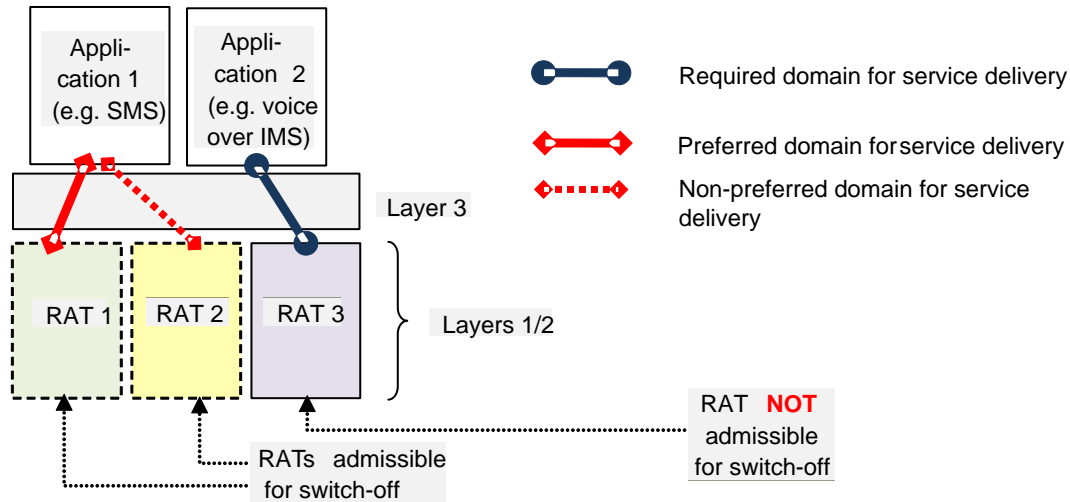

Figure 5.1.6-1: Cross layer dependency and relationship to inter-RAT energy saving options

The effect of switching off/on radio equipment for inter-RAT energy saving potentially counteracts above described domain selection principles. A hard setting for only one domain (i.e. no other domain admissible) could mean that inter-RAT energy saving is effectively not possible for certain cells, if and as long as such UE(s) need to be accommodated (under the assumption that service needs to be guaranteed for them).

Editor's note: It is FFS how the alignment between administrative settings per UE and inter-RAT energy saving procedures is achieved/maintained, and on which scale of dynamicity.

NOTE: A similar issue arises for UEs with support of only one particular RAT (e.g. LTE only UEs).

5.1.7 Key issue: Idle mode UEs with emergency bearer services

UEs in idle mode with emergency bearer services possibly await a callback from e.g. an emergency answering point or need to establish an outgoing emergency call; both can be deemed critical and in some cases life-saving.

The switch-off of cells for energy saving could result in a UE becoming temporarily unavailable for a callback, e.g. until the UE has successfully completed a location registration if the switched off cell is located near the boundary of a location registration area. (Of course this can also occur if the UE itself moves into a new location registrations area.)

Editor's note: it is FFS whether this needs to be considered, e.g. by exempting all cells potentially serving idle mode UEs with emergency bearer services from switch-off for energy saving.

Editor's note: it is FFS how the signalling between UE and core network can be optimized with respect to this issue.

5.1.8 Key issue: Impact of inter-RAT energy saving on signalling over SGs

For a UE configured to use CS fallback, according to figure 4.2.2.1 in 3GPP TS 29.118 [9] the SGs state has to be moved to SGs-NULI if a Location Update Request is received at VLR via A, Iu or Gs interface. That is the case some time after E-UTRAN radio access has been turned off, as the UE has no means to perform combined tracking area updates.

In the opposite direction, after E-UTRAN is switched on again, the SGs associations will be re-established by registration signalling of all affected UEs. There are two parts: EPS-NAS signalling and SGs signalling.

If any synchronization effect and consequently increased load for EPS-NAS signalling is found relevant (this is described as a key issue in subclause 5.1.5.2), it also applies over SGs for UEs configured to use CS fallback.

5.2 Switch-off/on of 3GPP home cells

5.2.1 General description

Switch-off of radio equipment in the home cell deployment scenario seems to be an attractive target case for energy saving, due to the expected mass of equipment (seen in total, i.e. for the whole population). Key characteristics of this scenario are:

- in many cases the overlay by the macro network exists (except in the case where home cells are deployed for reasons of coverage extension);
- the users are aware of (or even configure) the switch-off/on times; and
- the number of UEs potentially affected by the switch-off of one single home cell is very small, compared to a macro cell.

For the enterprise scenario, the second and third bullets may not apply.

5.2.2 Key issue: Incidental synchronization of H(e)NB switch-off/switch-on

For marketing reasons and potentially also due to stronger legal requirements for energy saving, the support of the simplest energy saving feature, namely switch-off during periods of expected inactivity (e.g. according to a daily or weekly schedule), may become a standard feature. In this case configuration settings for the switch-off and switch-on times need to be provided. Potentially there could be sources of incidental, unwanted synchronization, e.g.:

- factory pre-settings for the energy saving mode, e.g. 24:00 for switch-off and 06:00 for switch-on, which may not be changed by a majority of users;
- even if configuration settings are changed by users, there may be habits to set them to almost identical times. As an example, many people know that they go to sleep immediately after their favourite TV broadcast and may set the switch-off time accordingly; or
- another problematic case would be if an implementation allowed configuration settings to be selected only from a few predefined times (e.g. only half-hourly).

In all the above cases mass events regarding re-selection of cells and, depending on the structure of tracking areas, NAS signalling may result.

5.3 Switch-off/on of WLAN access networks in 3GPP I-WLAN

5.3.1 General description

Switching off a WLAN access network has the consequence that it will no longer be detected in active or passive scanning (see subclause 4.3.1 in 3GPP TS 24.234 [4]), therefore it would drop out as a candidate for 3GPP I-WLAN initial procedures. On the other hand, if switch-off for energy saving is foreseen at all, detecting an active SSID in scanning does not guarantee that it will remain in operation. If a SSID is deactivated while the UE is connected to it, this produces for the UE essentially the same effect as if the UE lost coverage by movement; however, in the network the difference is that WLAN actions, e.g. the WLAN initiated disconnection procedure as defined in subclause 7.5 of 3GPP TS 23.234 [3], can no longer be performed. If I-WLAN coverage for the UE remains (i.e. it is an intra-RAT energy saving case), according to 3GPP TS 24.234 [4] both the WLAN UE 3GPP I-WLAN re-selection procedure and the WLAN UE PLMN re-selection procedures have to be performed.

For access network selection with 3GPP I-WLAN some configuration data in the UE are foreseen (see subclause 5.1 of 3GPP TS 24.234 [4]): "User Controlled WLAN Specific Identifier list" and "Operator Controlled WLAN Specific Identifier list", both including a priority for selection. These lists have currently a static character.

NOTE: the analysis of activation status of WLAN access networks inter-connected to EPC via ePDG is covered in subclause 5.4.

5.3.2 Key issue: Latency associated with WLAN access network re-selection after switch-off (WLAN 3GPP IP access)

A compact view of what happens (for one UE) when a WLAN access network is switched-off is illustrated in figure 5.3.2-1 (non-roaming case; for simplicity WAG is not shown, and it is assumed that the same PDG can be reached).

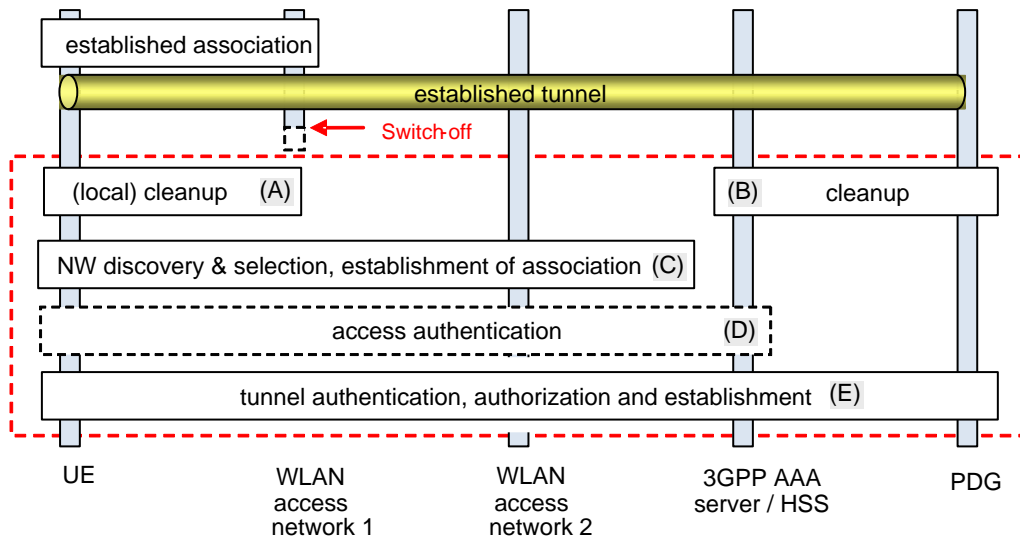

Figure 5.3.2-1: Compact view of procedures after switch-off of WLAN access network in 3GPP I-WLAN

Taking into account the number of signalling steps (e.g. counted from figure 4 and figure 7A in 3GPP TS 33.234 [5]) it becomes apparent that current procedures are not optimal for switch-off of a WLAN access network; the latency associated with the dashed box in figure 5.3.2-1 likely degrades the user experience.

5.3.3 Key issue: Mass effect resulting from WLAN access network re-selection after switch-off

WLANs can be considered a means to enhance capacity for mobile users in hotspots. If their switch-off is foreseen, the resulting mass effect has to be analysed; this can also be derived from figure 5.3.2-1, differentiating between procedures local to every UE and procedural parts running on the same network elements for the affected mass of UEs.

As an example case, the closing of a WLAN hot spot can be imagined: I-WLAN connectivity for e.g. ~100 users was provided via a WLAN access network 1, it is turned off and users have to be accommodated by alternative WLAN(s).

Analysing figure 5.3.2-1 regarding mass events in the network, the following is noticed:

Procedure A: local action per UE, therefore no mass event;

Procedure B: mass event on PDG, 3GPP AAA server / HSS;

Procedure C: mass event in WLAN access network 2;

Procedure D: mass event in WLAN access network 2 and 3GPP AAA server / HSS; and

Procedure E: mass event in WLAN access network 2, 3GPP AAA server / HSS and PDG.

NOTE: for an estimation of the scale of the mass effect it has to be taken into account that procedure D is optional and procedure E is only performed for WLAN 3GPP IP access.

Every mass event effectively consists of a peak in signalling. Further observations and assumptions can be made:

- (over)load in one network entity may lead to the broadening of the signalling peak in other nodes due to delay and queuing; e.g. for procedure D, (over)load in the WLAN access network 2 leads to broadening of the signalling peak in 3GPP AAA server / HSS and PDG;

- load resulting from procedure B and procedure D adds up in 3GPP server / HSS, load resulting from procedure B and procedure E adds up in PDG;
- if there is a multiplicity of alternative WLANs or PDGs, the load problem is reduced by this factor for them. But as a consequence, the above mentioned broadening of peak signalling may be reduced, or may not happen at all, for the other nodes; and
- even if all load can be accommodated easily by the WLAN access network(s), there is one danger: if e.g. due to identical closing times of hotspot venues the switch-off of many WLAN access networks happens at approximately the same time, this is a drastic stress scenario for the backend 3GPP I-WLAN related infrastructure (3GPP AAA server / HSS and PDG).

5.4 Switch-off/on of non-3GPP access networks

5.4.1 General description

The switch-off of a non-3GPP radio access can occur on a varying scale, from a single access point to a whole metro area network or a country-wide set of hotspots. As indicated in table 4.1, with current 3GPP specifications it can be handled as a (non-optimized) handover on IP layer. Handover procedures in 3GPP TS 23.402 [16] do not specify details of the trigger for handover initiation, but discovery of the availability of a target radio access is the prerequisite. Two cases exist:

1. If the non-availability of a non-3GPP radio access (due to switch-off) can be known sufficiently well in advance, then this can be used as a trigger and timely handovers are possible.
2. Another case is constituted when the UE is not aware of the imminent switch-off and just loses radio coverage of its currently selected RAT and access network. With current 3GPP specifications the UE behaviour is left implementation specific (only network selection and re-selection upon switch-on of the UE and recovery from lack of coverage, but not upon detection of lack of coverage is specified). This affects only the initial step of the handover procedure (trigger function, containing access network selection), the rest remains unchanged. Still, the likely result is added latency and thus a less seamless handover.

5.4.2 Key issue: Degradation of service due to switch-off of non-3GPP access networks

NOTE: the terms "planned" / "unplanned" handover are not formally defined in 3GPP and used here for the sake of concise description.

Non-3GPP accesses have been integrated into EPS with the aim to provide service continuity across accesses (currently by virtue of non-optimized, IP based handovers) and as seamless as possible. In figure 5.4.2-1 the general sequence of such a handover from non-3GPP access to E-UTRAN access is sketched, as deduced from clause 8 of 3GPP TS 23.402 [16]. The assumption of a "planned" handover is taken, i.e. that the procedure for establishing connectivity via the 3GPP access can essentially be run in parallel to the established connection via the non-3GPP access.

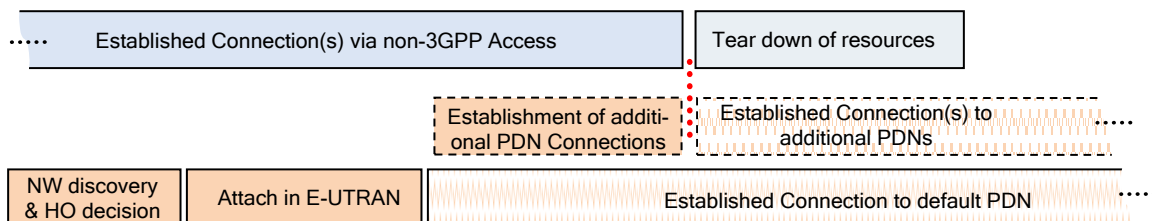

Figure 5.4.2-1: Compact view of procedures in (planned) handover from non-3GPP access to 3GPP access

When a switch-off of a non-3GPP access occurs, then without any further means for mitigation, the handover procedure can only be initiated after the UE has detected the loss of the non-3GPP access and becomes therefore unplanned.

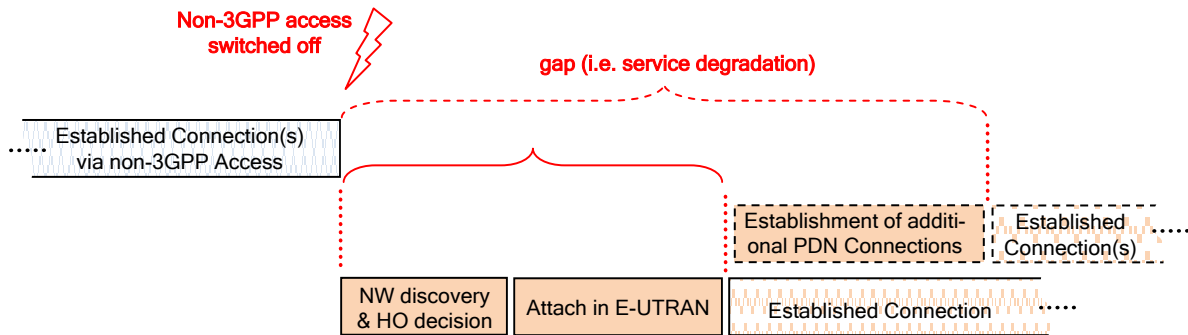

Figure 5.4.2-2: Compact view of procedures in (unplanned) handover from non-3GPP to 3GPP access

As a consequence, the issue of service degradation will always occur, even for UEs which would support the planned handover. The gap in connectivity may become even larger in case of multiple PDN connectivity.

5.5 Power adaptation for 3GPP macro cells

5.5.1 General description

NOTE: This subclause is intended as illustration and baseline for CT1’s analysis. It does not mandate anything for RAN groups’ work; in case of conflict between this and RAN workgroups’ description the latter takes precedence.

Power adaptation of capacity enhancing cells can be utilized for energy saving in the case of overlaid cell coverage, as shown in figure 5.5.1-1. Here a case is shown where the target cell remains in operation, but with reduced power, thus reduced coverage; another case could be if the power for the target cell is reduced to a minimum, so that subsequently it can be switched off without any further impact on UEs (as they then will have re-selected other cells). Obviously the process can be performed slowly enough not to create a similar issue as described in subclause 5.1.5.

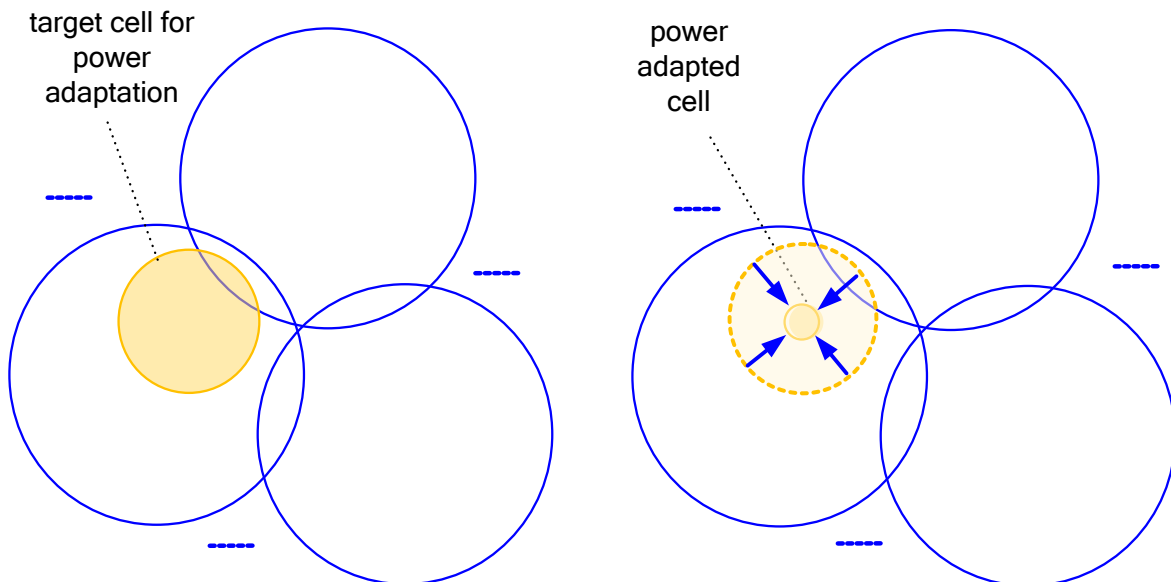

Figure 5.5.1-1: Power adaption for capacity enhancing cells in 3GPP macro network, due to energy saving (left: normal mode, right: energy saving mode)

Power adaptation of cells allows an overall power saving even in the case of non-overlaid cell coverage. This use case is described in more detail in annex A of 3GPP TS 32.551 [6], and the adaptation process is depicted in figure 5.5.1-2.

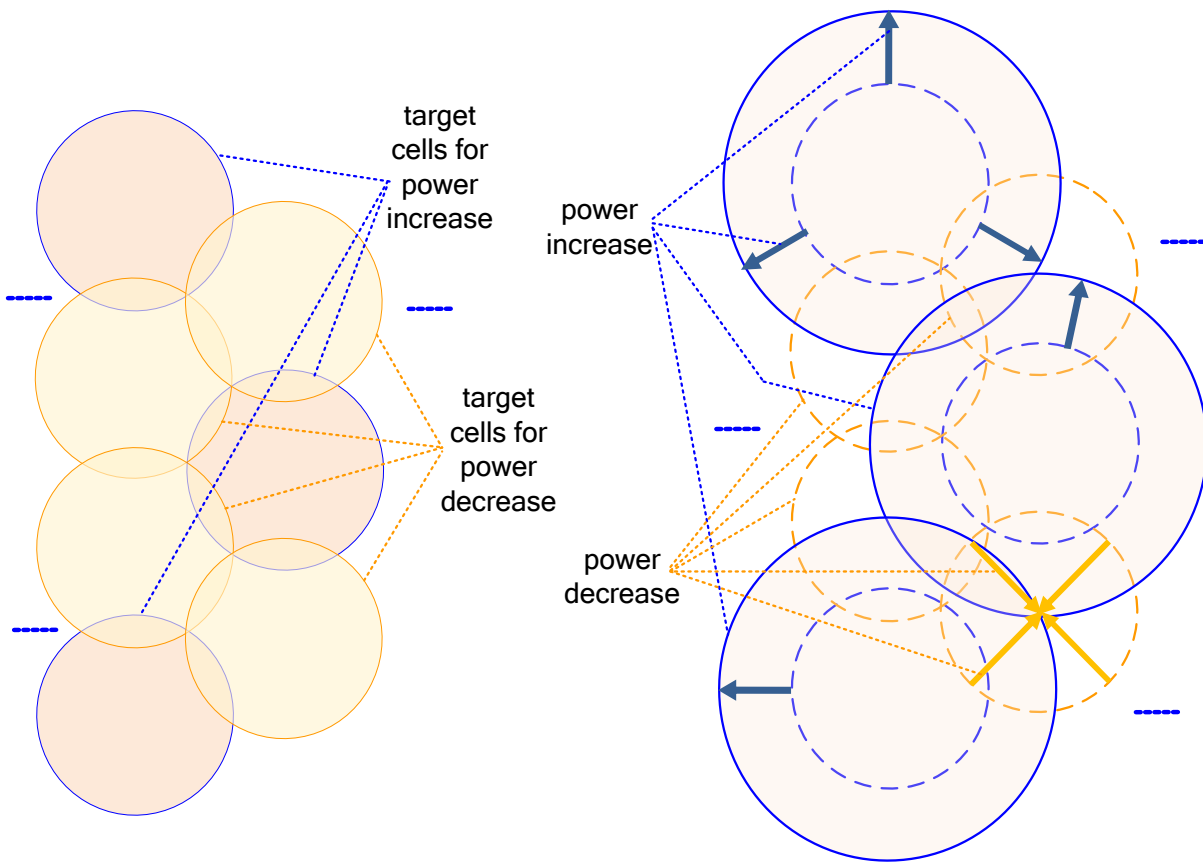

Figure 5.5.1-2: Power adaption for non-overlaid cells in 3GPP macro network, due to energy saving of one cell (left: normal mode, right: energy saving mode)

Again, target cells for energy saving decrease their power until their coverage has become sufficiently small, so that subsequently they can be switched off. Neighbouring cells correspondingly increase their power and coverage and thus fill the area.

5.5.2 Key issue: Coverage boundaries

NOTE 1: This subclause does not mandate anything for RAN groups' work; in case of conflict between this and RAN workgroups' description the latter takes precedence.

Although the principle of power adaptation of macro cells as described in subclause 5.5.1 avoids coverage holes in the (overall, outdoor) macro cell coverage itself, there is no co-operation with non-3GPP accesses. It thus seems unlikely that it can avoid additional dynamics of the coverage boundaries on the smaller scale e.g. towards indoor areas. Especially for these areas alternatives, e.g. non-3GPP accesses, are foreseen.

Editor's note: details of coverage dynamics with power adaptation are out of scope here and should be characterized by RAN groups.

If the movement of macro cell coverage boundary, due to power adaptation of a macro cell for energy saving purpose, is such that it reduces the overlap with the indoor radio access, it potentially forces some/more UEs to use the alternative radio access (by inter-RAT handovers). Figure 5.5.2-1 illustrates the principle of this possible change in coverage boundaries due to power adaptation. (Note that in the worst case, if the coverage overlap is totally eliminated, it could lead to lack of service for UEs; this could happen if the non-3GPP access dimensioning is done for the macro cell configuration without energy saving.)

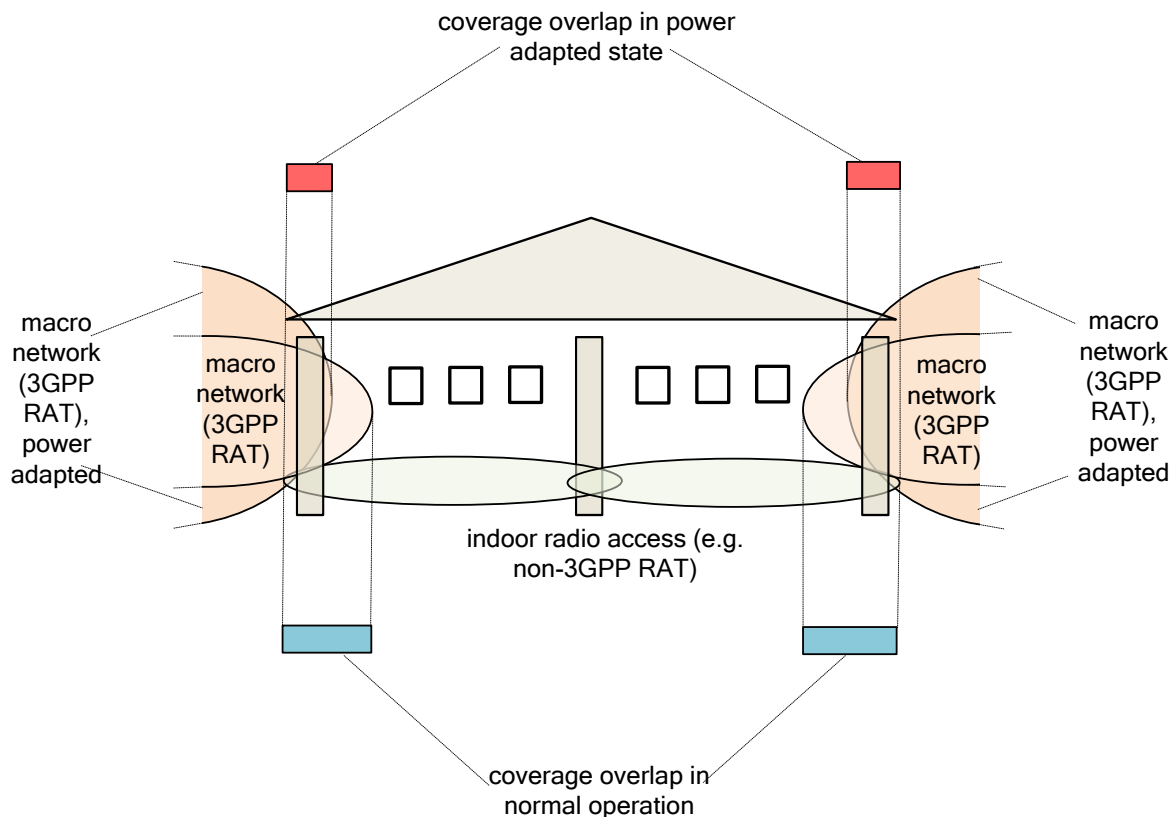

Figure 5.5.2-1: Illustration of coverage boundaries between macro and indoor coverage with and without power adaptation of macro cells

NOTE 2: For some UEs a reduced overlap of coverage can also have a positive side-effect (reduced toggling between accesses).

The above described effect from UE to network signalling per single power adaptation action is expected to be small, due to the limited amount of affected UEs and spreading out over time. However, if aggregation occurs over a larger area of the network within a short time, the issue like described in subclause 5.6.1 "Key issue: Increased ANDSF load" will arise.

Additionally (independent of aggregation), for I-WLAN as the chosen alternative access, an analogous effect as described in subclause 5.3.2 "Key issue: Latency associated with WLAN access network re-selection after switch-off (WLAN 3GPP IP access)" will apply for affected UEs.

NOTE 3: The combination of switch off of macro cell and subsequent (forced) WLAN access network selection has not been captured as a separate scenario, due to the assumption that any energy saving mechanism in 3GPP access will avoid coverage holes.

5.6 Common issues

5.6.1 Key issue: Increased ANDSF load

ANDSF can be interrogated by a UE for delivery of access network discovery information for non-3GPP accesses at any time after a secure connection has been set up between these two entities. The triggers for such queries are not specified.

There are potential relations between switch-off of RATs and UE-ANDSF communication, which could act as triggers for ANDSF interrogation:

- 1) Update of location information due to switch-off of radio equipment for inter-RAT energy saving:

If a RAT is no longer visible to a UE due to switch-off (e.g. E-UTRAN switched off), any previously delivered location information associated with this RAT parameter delivered to the ANDSF is no longer useful.

Consequently, the UE would most likely try to update ANDSF; although this is implementation specific behaviour, it is a reasonable and plausible one. For switch-on of a RAT a similar argument holds.

2) Refresh of ANDSF information, due to UE's pull policy:

The UE could always want to have best options for its decision about usage of access networks; if a RAT is switched off and was before deemed a suitable candidate (e.g. for a particular type of applications), the UE is left with fewer alternatives and could want to have reconsidered this fact by ANDSF (again, this is implementation specific, but likely). If a RAT, previously switched off and thus not visible to the UE, is switched on and the UE detects it newly in radio scanning, the UE could expect that previously delivered access network discovery information is outdated and could equally try to refresh this data.

NOTE 1: How the UE infers that a RAT is switched off is implementation dependent.

NOTE 2: As stated in 3GPP TS 24.302 [7], mechanisms to limit the frequency of queries transmission from the UE to the ANDSF are implementation dependant.

Both cases listed above seem uncritical for switch-off/on of single cells, but can become critical if many cells are switched off/on nearly at the same time. Due to the centralized nature of ANDSF this mass effect can aggregate over large areas.

5.6.2 Key issue: Signalling overload for multi-access and flow mobility

A UE can initiate, via the maintained access network, the removal of an access network from a PDN connection, after it has detected the loss of the associated radio coverage (see figure 5.5-1 of 3GPP TS 23.261 [17]). This procedure is started by a DSMIPv6 Binding Update message sent from the UE to the PDN GW/Home Agent and leads to subsequent further steps (Binding Acknowledgement, release of resources including security association).

If the switch-off, i.e. loss of an access network, happens in a large area at the same time, there is the danger that many UEs perform the DSMIPv6 update signalling within a short time. This can potentially lead to overload and delay in the control plane functionality of the PDN GW/Home Agent.

NOTE: When a radio access is switched off, IP packets in the user plane being routed via the corresponding interface will likely be lost.

In the opposite direction of switching (radio access is switched on again), the issue also exists in principle but seems less critical, because in this case UEs likely will show larger variance with respect to the latency regarding flow redistribution. The difference stems from the fact that UEs are not forced to act immediately in order to receive continuous service for all IP flows.

5.7 Additional analysis

5.7.1 Potential interaction between machine type communication and energy saving

Some type of machine type communication, e.g. reading out meter/sensor values or stock lists, is flexible with regards to the transaction time and is therefore thought to be suitable for handling in off-peak, especially night, hours. But this is also exactly the target time window for energy saving; therefore potential interactions between these two features need to be considered. In case of competing targets this needs to be resolved by intelligent configuration and use of the corresponding mechanisms.

Especially for support of machine type communication (but not limited to it) some extensions to NAS signalling procedures are defined in 3GPP TS 24.008 [21] and 3GPP TS 24.301 [12], as well as NAS protocol related configuration parameters defined in 3GPP TS 24.368 [20]. They can influence UE to core network signalling in a way relevant to energy saving, e.g.

- use of MM and SM backoff timers; and
- increase of periodic registration (LAU/RAU/TAU) timers.

Table 5.7.1-1 collects and analyzes potential interactions on NAS signalling level between these features in more detail.

Table 5.7.1-1: Potential interactions between (a) extensions to NAS signalling procedures and NAS protocol configuration parameters and (b) energy saving

Mechanism (reference)	Description	NAS signalling aspect relevant for this study	Comment
MM and SM backoff timers (see 3GPP TR 23.888 [8], subclause 6.22)	Under high load conditions, some MM and SM requests (Attach, PDP/PDN Activation, Service Request, ...) might be rejected, in which case the request is repeated at a later time.	1) An attach to the remaining active RAT (due to inter-RAT energy saving) could fall into this handling and experience delay.	Only relevant for devices with multiple radio interfaces.
		2) Peaks in NAS signalling become spread out over time; as a consequence, the net time window for energy saving could become smaller.	Relevant if signalling peaks are scheduled close to the intended target time for energy saving. It is assumed that the time window for energy saving is determined (also) based on signalling traffic.
Optimized periodic registration timer (see 3GPP TR 23.888 [8], subclause 6.20)	Possibility of longer periodic registration timers (defined locally at MME/SGSN or by subscription), so that the amount of registration update signalling is minimized.	1) Long enough periodic registration timer values, and their reset close enough to start of energy saving time window could avoid signalling traffic within this time.	Can allow a peaceful coexistence of both features, but requires careful, coordinated configuration.
		2) Location registrations induced by energy saving counteract the original optimization principle.	

An additional aspect to be considered is that a wide range of devices for the use cases described above is expected to be very price sensitive, thus they will likely support only one radio interface; this reduces the options for energy saving (no inter-RAT energy saving possible).

6 Potential optimizations and enhancements in procedures

6.1 Solution "Optimized configuration of tracking areas and TAI lists"

6.1.1 Description

This solution addresses key issues "Tracking Area Update signalling resulting from switch-off/on of macro cells" described in subclause 5.1.5 and "Idle mode UEs with emergency bearer services" as described in subclause 5.1.7.

The solution consists in overall configuration

- 1) of TAs in the network; or
- 2) TAI lists to be assigned to UEs,

in such a way that cells targeted for switch off are preferably avoided on boundaries of TAs or boundaries of the areas defined by TAI lists, respectively. The first variant means static configuration, while the second one allows for more dynamic handling (by MME).

NOTE 1: Solution variant 1) can be extrapolated in a straightforward manner to LA and RA configurations. Solution variant 2) can be applied only to TAs/E-UTRAN.

NOTE 2: Even if the TA/TAI list configuration fulfills the above criterion only partially, this reduces the severity of the related issues proportionally.

6.1.2 Benefits

No standardization effort is required for this solution.

6.1.3 Limitations

No full flexibility is possible, e.g. for deployment of capacity enhancing cells under changing conditions.

The effort for guaranteeing the optimized configuration increases with the number of affected cells and thus can become large if energy saving is applied massively (e.g. network wide).

6.1.4 Impacts on 3GPP Specifications

None.

6.2 Solution "Adding time dependence to configuration settings in MOs"

6.2.1 Description

This solution addresses key issue "Cross layer aspects" as described in subsection 5.1.6, in particular for inter-RAT energy saving.

The solution consists in adding time parameters to the following configuration parameters in OMA DM MOs, related to voice calls and multimedia sessions and defined in 3GPP TS 24.167 [10] and 3GPP TS 24.216 [11]:

3GPP TS 24.167: Voice_Domain_Preference_E_UTRAN, Voice_Domain_Preference_UTRAN.

3GPP TS 24.216: Preferred_domain

The time information is to be taken into account by UEs when initiating communication, in order to avoid the need for (possibly synchronized) domain transfer at the switch-off time of a RAT. As an example, if E-UTRAN is to be switched off at 24:00 h, the voice domain preference could be set to "CS Voice only" for a time window which starts sufficiently long before the target time for switch-off, e.g. to 23:40 h. The safety margin (here 20 minutes) should be chosen based on average call/session durations, so that most of the calls/sessions can be expected to end before the target switch-off time. This is illustrated in figure 6.2.1-1.

NOTE: Introducing time dependence to MOs does not imply that MO data has to be updated more often than before or close to points in time where the settings change.

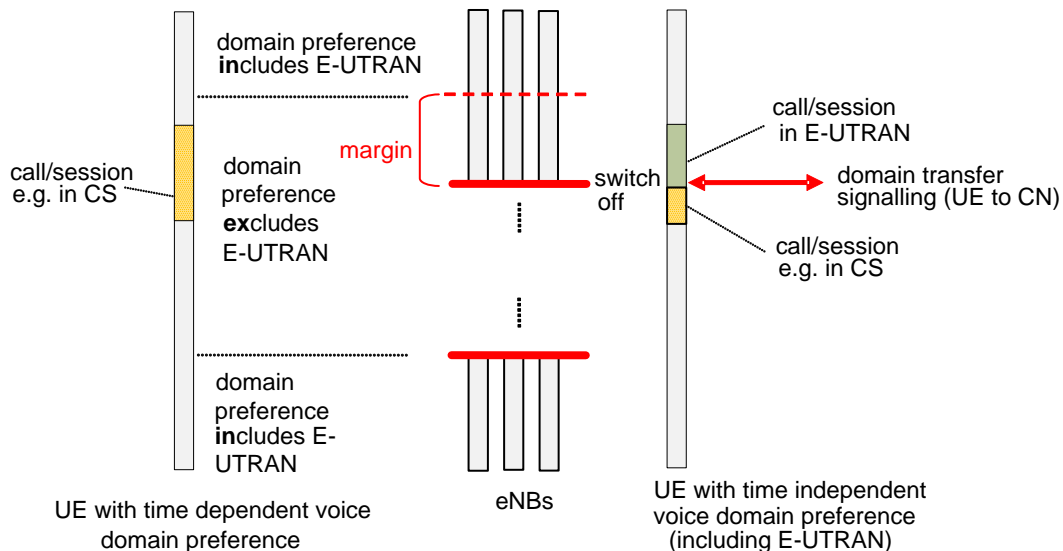

Figure 6.2.1-1: Example behaviour of UEs with/without time dependent operator preferences for voice domain selection

Some configuration settings currently do not differentiate between RATs, but only between CS and PS domains, and so the control per RAT is not directly possible. However, a preference for CS implicitly excludes E-UTRAN.

Additionally, these configuration settings could be made fully RAT specific.

6.2.2 Benefits

The solution reduces the amount of signalling for domain transfer (which is also time critical) both for the network and affected UEs, if these need to originate communication just before a RAT is switched off for the purpose of inter-RAT energy saving. Also, a potential but unnecessary deterioration of service experience can be avoided in a majority of cases.

6.2.3 Limitations

These operator preferences are specific for selected services (voice calls and multimedia sessions). These settings are currently not per PLMN; thus either a differentiation per PLMN has to be introduced, or the described time dependence is to be limited to the HPLMN.

This solution requires changes in UEs, and therefore the benefits do not apply for legacy UEs.

No full traffic steering is achievable with preferences only.

A certain fraction of calls with longer duration than the time margin configured before switch-off of the RAT will occur; for these the above mentioned benefit does not apply.

6.2.4 Impacts on 3GPP Specifications

Additions in 3GPP TS 24.167 [10] and 3GPP TS 24.216 [11], and enhancements in specifications of corresponding procedures (3GPP TS 24.301 [12] and 3GPP TS 24.237 [13]).

6.3 Solution "Dynamic radio access network sharing"

6.3.1 Description

This solution addresses all key issues listed in subclause 5.1.

Network Sharing with a Multi-Operator Core Network (MOCN), as defined in 3GPP TS 23.251 [14], is an established means to leverage reduced operator's expense for radio access infrastructure. Even though currently it is assumed to be firmly and permanently configured, it can also be used in a more dynamical form, i.e. the radio access can be shared between two or several operators only during off-peak hours for the purpose of energy saving. To this end, no normative modifications are required in 3GPP specifications. In particular, no impacts on UE functionality are foreseen, but it needs to be recognized that the solution works more efficiently for network sharing supporting UEs (see below).

The solution scheme is shown in figure 6.3.1-1 for the example of two operators switching off their RANs and also sharing them on alternate days. Consequently they gain alternately the complete saving of energy of radio nodes for the switch off period. In more detail, in a period when the RAN of PLMN A is switched off, the configuration of PLMN B is changed to enable RAN sharing with PLMN A; after the RAN of PLMN A has been switched on again, the configuration of PLMN B is changed back to normal, to avoid the RAN sharing. As the switch-off of the RAN and the configuration change cannot be assumed to be perfectly synchronized, a small time safety margin needs to be applied.

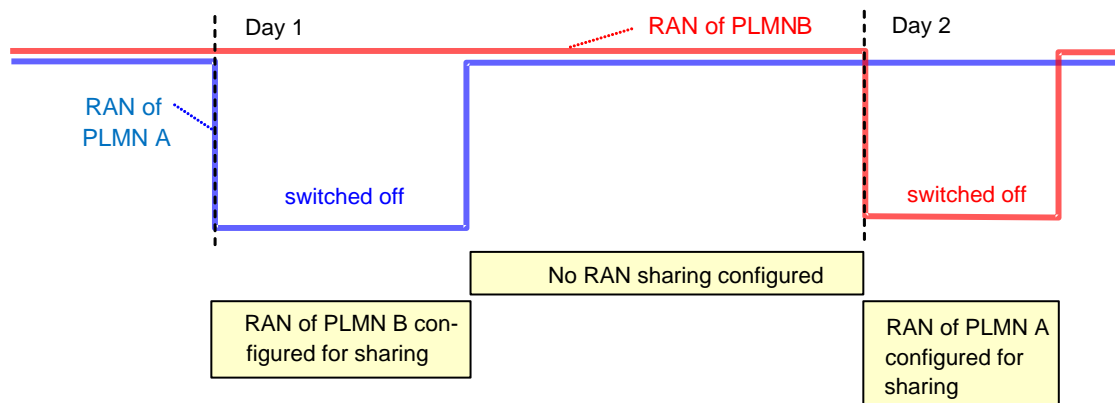

Figure 6.3.1-1: Dynamic network sharing scheme for energy saving (two operators)

According to TS 23.251 [14], during the time of sharing, radio nodes broadcast PLMN information for both PLMNs. Subsequently the behaviour differs for supporting and non-supporting UEs:

- supporting UEs (see subclause 7.1.3 in 3GPP TS 23.251 [14]): they are able to decode the multiple PLMN information in the system broadcast information and select the PLMN on their own. The RPLMN should again be broadcast in the shared state, so no additional PLMN selection is triggered.
- non-supporting UEs (see subclause 7.1.4 in 3GPP TS 23.251 [14]): these are not able to decode the multiple PLMN information and consequently cannot control network selection. Instead, the RAN and core network perform this task by initial routing and potential re-direction. The impact on NAS signalling is that for these UEs additional registration updates and Identity Request/Response and Authentication dialogues can result.

6.3.2 Benefits

This solution allows to save the energy consumption of the RAN of at least one operator completely during off-peak time.

6.3.3 Limitations

This solution requires tight coordination between participating operators. National roaming (at least for non-supporting UEs during sharing period) must be allowed, and scheduling of network sharing for one PLMN must always match correctly the switch off times of the other PLMN(s).

The additional NAS signalling for non-supporting UEs has to be taken into account properly; e.g. it could be necessary to spread out the switch-off time sufficiently over time and areas.

The dynamic change of network configuration related to RAN sharing could require enhancements of current OAM procedures and data.

NOTE: the OAM aspects need to be considered by SA5 WG.

6.3.4 Impacts on 3GPP Specifications

No impacts of normative character are needed. It could be worth to include clarifications for this use case, e.g. in 3GPP TS 23.401 [15].

6.4 Solution "Network based handling for multi-access and flow mobility"

6.4.1 Description

This solution addresses the key issue "Signalling overload for multi access and flow mobility" as described in subclause 5.6.2.

In this solution the Home Agent functionality in the PDN GW is enhanced by some knowledge about availability of access networks. The already existing procedure "network initiated removal of an access network from a PDN connection" as specified in subclause 5.9 of 3GPP TS 24.303 [18] is used to redistribute the IP flows via the access networks remaining operational, in a smooth manner and early enough. To this end, the Binding Revocation Indication (BRI) messages sent to all affected UEs could be spread out over time, while still allowing completion of the process before the access network is switched off. This is illustrated in figure 6.4.1-1.

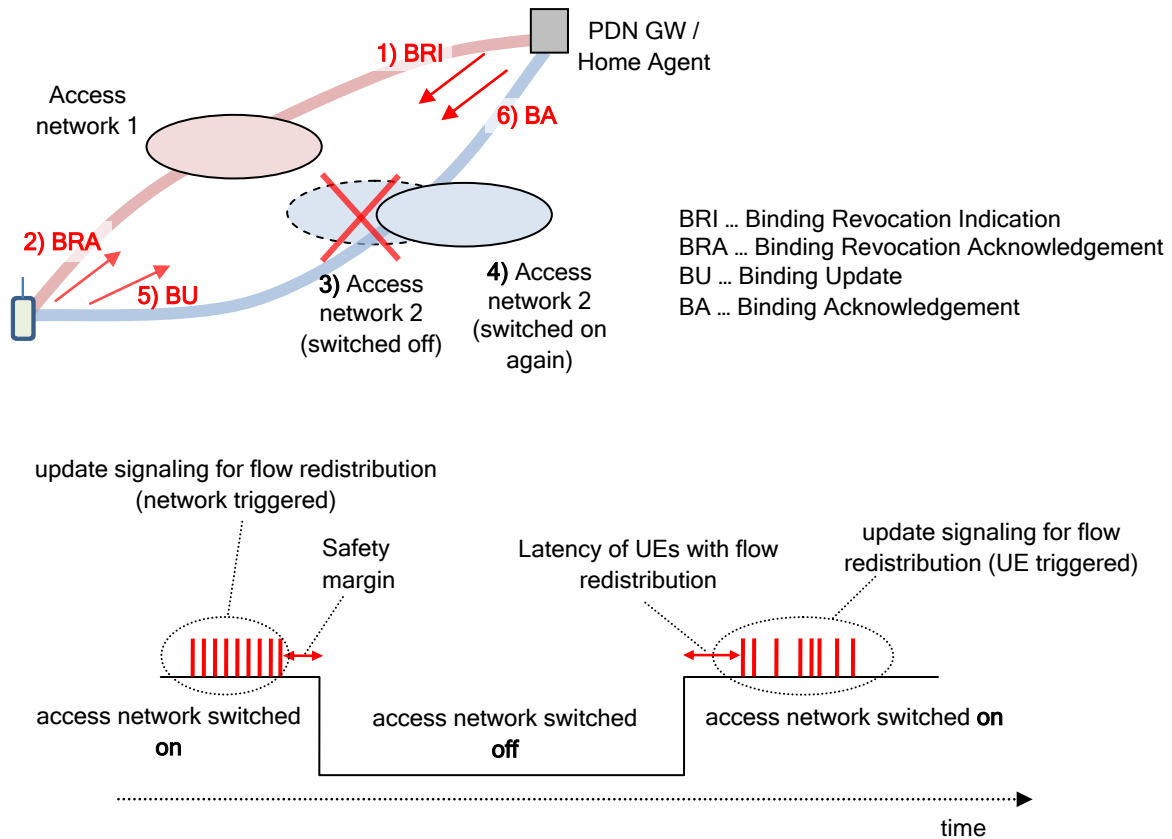

Figure 6.4.1-1: Overall scheme of signalling with network based handling for multi access and flow mobility

In the upper part of figure 6.4.1-1 the principal sequence of steps in signalling between the UE and Home Agent is shown for one UE. In the lower part the aggregated behavior, including desired safety margin before switch-off and expectable latency after switch-on is sketched. Because the redistribution of IP flows after switch-on is purely UE dependent, the signalling will be more irregular.

No further assumptions can be made regarding how the Home Agent acquires its knowledge about the scheduled downtimes of access networks, as this is out of scope of this study.

6.4.2 Benefits

Potential overload on PDN GW/Home Agent can be avoided. IP flows can be moved from access networks subject to switch-off to access networks remaining operational; this reduces packet loss and thus improves user experience.

6.4.3 Limitations

How the HA acquires knowledge about downtime of access networks is left unspecified. Although static provisioning of data seems possible for small scale deployments, a fully standardized solution for this part would require additional specification effort (in CT4's or SA5's domain of work).

6.4.4 Impacts on 3GPP Specifications

No normative impacts foreseen; however, it could be worthwhile to document this use case in an informative manner.

6.5 Solution "Activation times in ANDSF data"

6.5.1 Description

6.5.1.1 Variant 1

This variant of the solution consists in enhancing access network discovery information data, stored and provided by ANDSF for non-3GPP access networks, with activation status information (activation time windows). If lacking (default) it means that these access networks are assumed to be always active.

The information on activation time can be taken into account for UEs decisions on:

- access network (re-)selection: it can be avoided that the UE tries to select an access network which actually is not switched on. Although the UE would detect this situation by access specific means (e.g. probing or scanning) it is more efficient to know it in advance;
- (non-optimized) handover: if the UE is using an access network known to be switched off soon, it can initiate the handover early enough, so that the whole procedure can be completed before the current radio is lost;
- flow re-distribution: if the UE is using an access network known to be switched off soon, it can initiate the flow-redistribution early enough, so that the whole procedure can be completed before the current radio is lost; and
- ANDSF interrogation: the UE, when probing or scanning for a radio access, will not detect a mismatch with ANDSF data. Therefore a potential cause for ANDSF interrogation is avoided.

6.5.1.2 Variant 2

In this variant the activation times of access networks are considered implicitly with all relevant ISMP and ISRP rules. Evaluating these enhanced policy rules will result in optimized UE behavior equivalent to the one described above for variant 1.

6.5.2 Benefits

This solution helps to solve the key issue "Increased ANDSF load" described in subclause 5.6.1. The additionally provided information avoids that the UE, due to finding a persistent mismatch between data received from ANDSF and the real availability of access networks, would deem the data being outdated and try to refresh it from ANDSF.

This solution can also mitigate key issues "Latency associated with WLAN access network re-selection after switch-off (WLAN 3GPP IP access)" described in subclause 5.3.2 and "Mass effect resulting from WLAN access network re-selection after switch-off" described in subclause 5.3.3, as it allows UEs to re-select WLAN access network proactively.

This solution alleviates key issue "Degradation of service due to switch-off of non-3GPP access networks" described in subclause 5.4.2, due to the fact that handovers can be initiated timely enough.

This solution mitigates key issue "Signalling overload for multi-access and flow mobility" as described in subclause 5.6.2, because flow-redistribution can be done timely enough (similar to the solution described in subclause 6.4, but initiated by the UE instead of the Home Agent).

6.5.3 Limitations

There can be no guarantee that the activation times announced explicitly or considered implicitly in policy rules by ANDSF match perfectly the reality; e.g. it could happen that a radio access is still switched off, despite being announced as active, and vice versa.

Announcing activation times could lead advanced users to wait and start requesting their services immediately after the switch-on of a particular radio access; this behavior should be considered by including sufficient margins with activation times.

Dynamic handling e.g. for taking into account current load cannot be achieved by this solution.

6.5.4 Impacts on 3GPP Specifications

For variant 1, the following 3GPP specifications require enhancements for this solution:

- 3GPP TS 23.402 and potentially 3GPP TS 23.261: enhancement in functional description (stage 2);
- 3GPP TS 24.312: additional information elements defining the activation time windows of e.g. GERAN_CI, UTRAN_CI, EUTRA_CI, Sector-ID, BS-ID, HESSID, SSID, BSSID; and
- 3GPP TS 24.302: reflect the usage of additional information (activation time windows) in procedural descriptions.

For variant 2 there is no impact on 3GPP specifications.

7 Conclusions

7.1 General overview of key issues and solutions

Table 7.1-1 lists the key issues and how they are covered by documented solutions.

Table 7.1-1: Key issues and solutions

Sub-clause	Energy saving scenario / Key issue	Solution (sub-clause)	Comment
5.1	Switch-off/on of Macro cells		
5.1.5	Registration signalling resulting from switch-off/on of macro cells	6.1, 6.3	
5.1.6	Cross layer aspects	6.1, 6.2, 6.3	
5.1.7	Idle mode UEs with emergency bearer services	6.3	
5.1.8	impact of inter-RAT energy saving on signalling over SGs	6.3	
5.2	Switch-off/on of home cells		
5.2.2	Incidental synchronization of H(e)NB switch-off/switch-on		Solution(s) potentially by other WGs or vendors
5.3	Switch-off/on of I-WLAN		
5.3.2	Latency associated with WLAN access network re-selection after switch-off (WLAN 3GPP IP access)	6.5	
5.3.3	Mass effect resulting from WLAN access network re-selection after switch-off	6.5	
5.4	Switch-off/on of non-3GPP accesses		
5.4.2	Degradation of service due to switch-off of non-3GPP access networks	6.5	
5.5	Power adaptation for 3GPP macro cells		
5.5.2	Coverage boundaries		Dependence on more details from RAN WGs
5.6	Common issues		
5.6.1	Increased ANDSF load	6.5	
5.6.2	Impacts for multi-access and flow mobility	6.4, 6.5	

7.2 Detailed conclusions

The following conclusions are drawn:

- Several key issues (in particular those in subclauses 5.1.5, 5.1.8, 5.2.2, 5.3.3, 5.6.1 and 5.6.2) are related to potential widescale synchronized UE behaviour. As a general strategy, and independent of individual solutions, these issues can be mitigated by spreading out switching (on/off) times sufficiently.
- Several possible solutions have been defined which do not have any impact on the 3GPP specifications (those described in subclause 6.1, 6.3, 6.4 and partially 6.5 [variant 2]), and as an implementation option they could be exploited as of today.
- For energy saving in 3GPP access, subclauses 6.1 and 6.3 provide some proposed solutions which relate also to functionalities in the RAN. Taking into account the fact that the solution described in subclause 6.1 is an intra-operator one, an operator can consider this solution for deployment in the first place. In addition, if an operator has to meet high targets for energy saving and tight coordination including network sharing with other operator(s) is feasible, s/he could consider the solution described in subclause 6.3.

- For energy saving in non-3GPP access, the solution described in subclause 6.5 solves several key issues. However as variant 1 would introduce new normative requirements onto 3GPP entities while variant 2 does not, it seems logical to propose, in the initial phase of implementing an energy saving strategy, variant 2 as a way forward.

Annex A (informative): Change history

Change history							
Date	TSG #	TSG Doc.	CR	Rev	Subject/Comment	Old	New
2010-06					Initial skeleton provided by rapporteur		0.0.0
2010-07					Contributions agreed in CT1#65: C1-102713, C1-102714, C1-102715, C1-102716, C1-102717; editorial alignment	0.0.0	0.1.0
2010-07					Further editorial improvement incl. enforcement of drafting rules.	0.1.0	0.1.1
2010-09					Contributions agreed in CT1#66: C1-103134, C1-103251, C1-103252, C1-103253, C1-103548	0.1.1	0.2.0
2010-09					Correct implementation of C1-103134 and further editorial improvements	0.2.0	0.2.1
2010-10					Contributions agreed in CT1#67: C1-104245, C1-104246, C1-104247, C1-10443; editorial corrections and re-drawing of figures in Visio	0.2.1	0.3.0
2010-11					Contributions agreed in CT1#68: C1-104759, C1-105145, C1-105147, C1-105246	0.3.0	0.4.0
2011-02					Contributions agreed in CT1#69: C1-110228, C1-110722, C1-110723, C1-110724, C1-110725, C1-110726	0.4.0	0.5.0
2011-03					Contributions agreed in CT1#70: C1-111447, C1-111448, C1-111449, C1-111507; editorial corrections	0.5.0	0.6.0
2011-03	CT-51	CP-110149			Version 1.0.0 created for presentation to CT-51 for information.	0.6.0	1.0.0
2011-05					Contributions agreed in CT1#71: C1-111921, C1-112175	1.0.0	1.1.0
2011-05	CT-52				Version 2.0.0 created for presentation to CT-52 for approval.	1.1.0	2.0.0
2011-06	CT-52				Version 11.0.0 created after approval at CT-52	2.0.0	11.0.0